

LEGEND

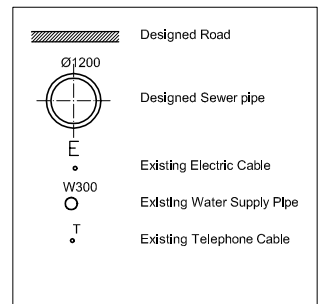

NO.	DATE	DESCRIPTIONS	BY	APRO.

REVISIONS

PROJECT MANAGEMENT UNIT FOR
HO CHI MINH CITY
WATER ENVIRONMENT IMPROVEMENT

THE DETAILED DESIGN STUDY ON HO CHI MINH CITY
WATER ENVIRONMENT IMPROVEMENT PROJECT
IN THE SOCIALIST REPUBLIC OF VIET NAM

PACKAGE B
PUMP DRAINAGE IMPROVEMENT
BEN ME COC(1) AREA

CROSS SECTION OF SEWER, ROAD
AND TEMPORARY DIKE (23)

BM1- W2 (0+800 - 0+861.77)

SCALE :	1:100
JAPAN INTERNATIONAL COOPERATION AGENCY (JICA)	
PACIFIC CONSULTANTS INTERNATIONAL	
DESIGNED TOKUMASU TOSHIKI	CHECKED KONDO MASAMI
DATE : JUNE 2001	DWG. No. PB - PDI - BMC1-241

ALONG BM1 - E 1

ALONG BM1 - E 1.1
a. (New dike)

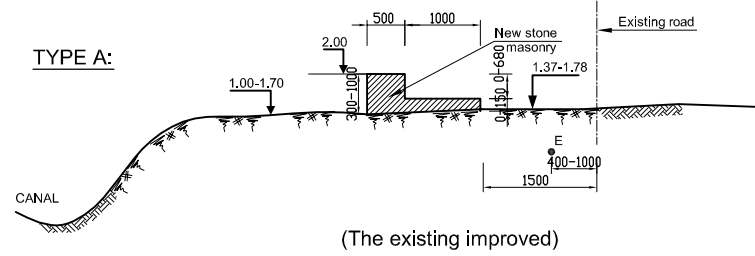

(The existing improved)

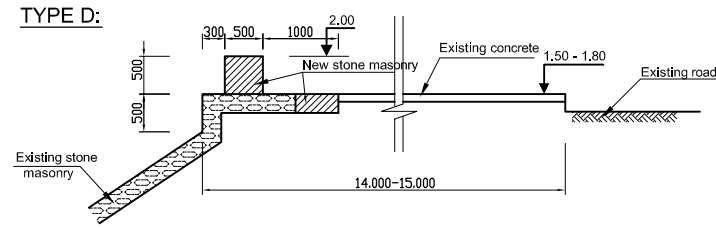

ALONG BM1 - E 1.2

a. (New dike)

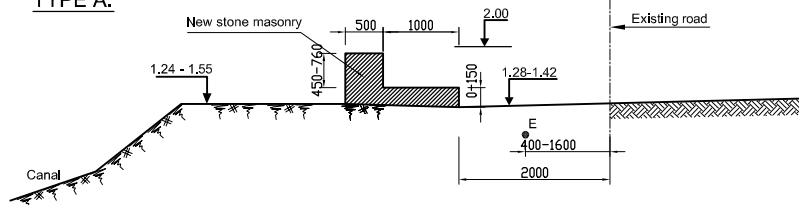

b. (The existing dike improved)

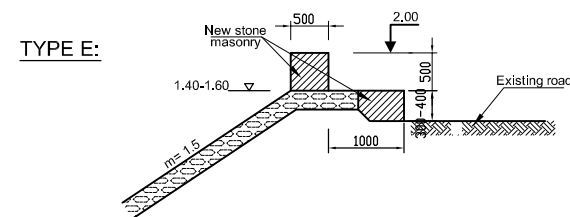

ALONG BM1 - E 1.3

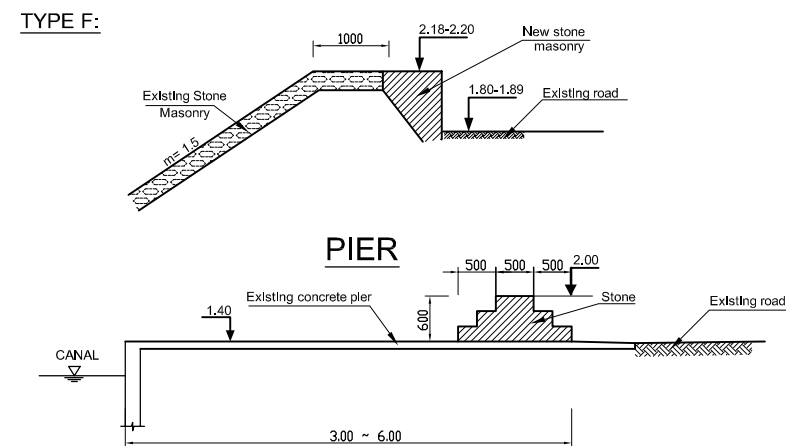
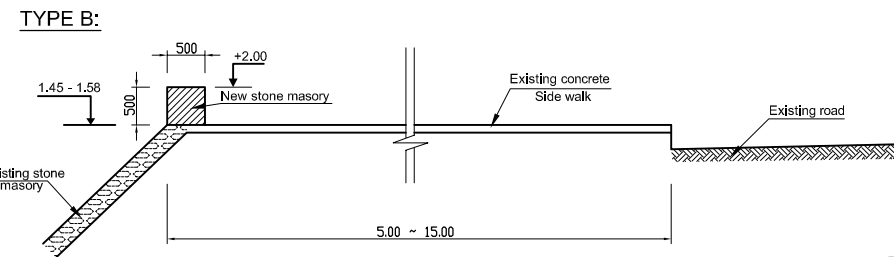

ALONG BM1 - E 3

ALONG BM1 - E 3.1

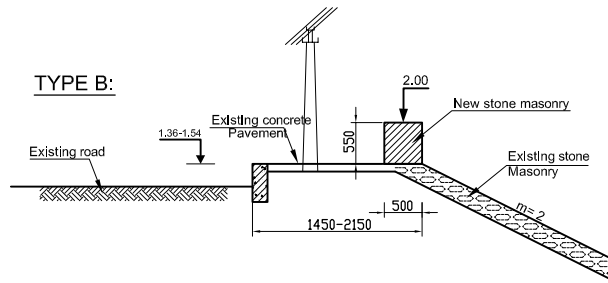

ALONG BRIDGE CANAL N°2

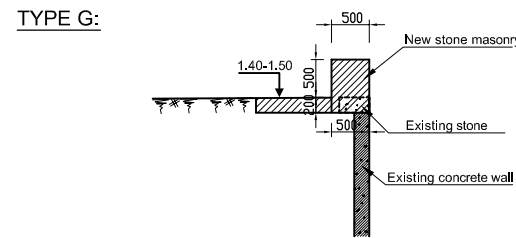

ALONG BM1 - E 3.2

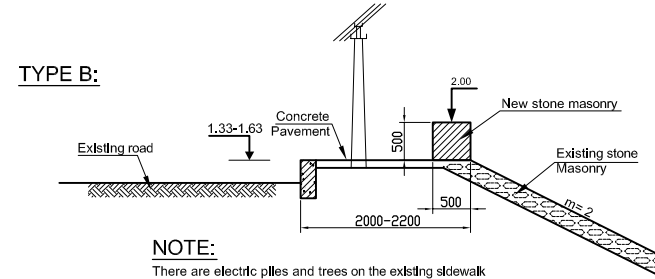

NOTE:
There are electric piles and trees on the existing sidewalk

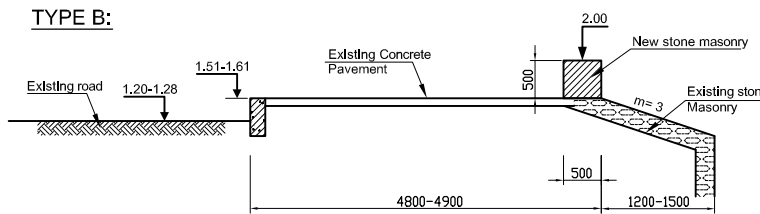

ALONG BM1 - W2

ALONG BM1 - W2.1, W2.2

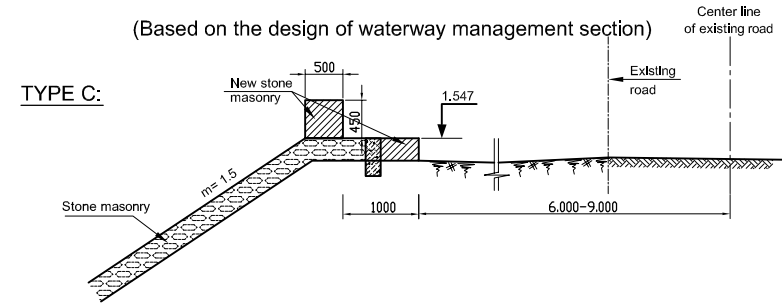

ALONG BM1 - W1

ALONG BM1-W1.1

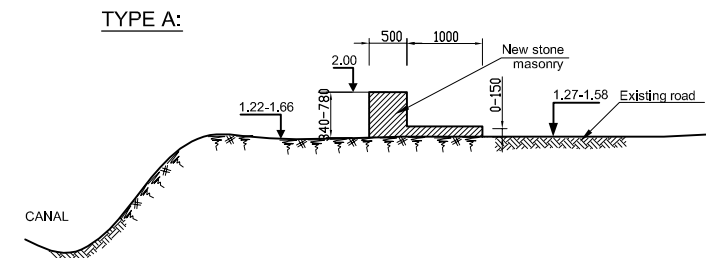

ALONG BM1-W1.2

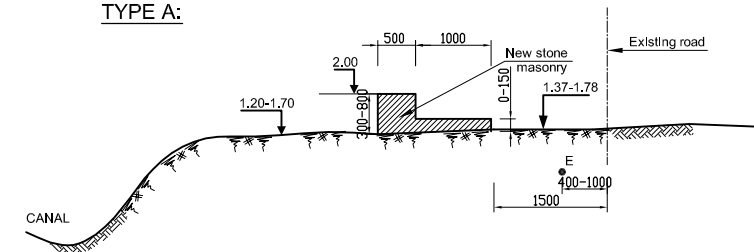

Along BM1-W1.4:

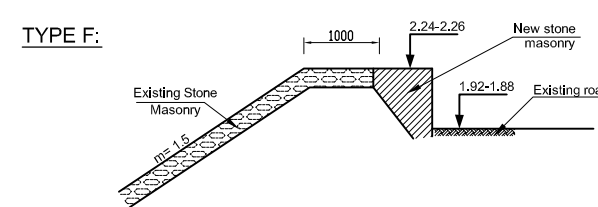

NOTE:
Structure of temporary dike (Type A,B,C,D,E,F,G)
Show in drawing DWG.No. PB - PDI - BMC1 - 243

TYPE	Length (m)	VOLUME OF TEMPORARY DIKE (Unit: m3)			
		Excavation	Sandy soil back filling	Leveling concrete	Stone Masory
A	1550	1194	450	155	1349
B	1077				296
C	910	182	46		341
D	365	102	26		168
E	61	5		2	29
F	105	9	13	3	21
G	224	114		11	157
PIER	37		11		11

NO.	DATE	DESCRIPTIONS	BY	APRO.
REVISIONS				
PROJECT MANAGEMENT UNIT FOR HO CHI MINH CITY WATER ENVIRONMENT IMPROVEMENT				
THE DETAILED DESIGN STUDY ON HO CHI MINH CITY WATER ENVIRONMENT IMPROVEMENT PROJECT IN THE SOCIALIST REPUBLIC OF VIET NAM				
PACKAGE B PUMP DRAINAGE IMPROVEMENT BEN ME COC (1) AREA TYPICAL CROSS SECTION OF TEMPORARY DIKE				
SCALE : 1 : 50				
JAPAN INTERNATIONAL COOPERATION AGENCY (JICA)				
PACIFIC CONSULTANTS INTERNATIONAL				
DESIGNED TOKUMASU TOSHIAKI	CHECKED KONDO MASAMI			
DATE : JUNE 2001	DWG. No.PB -PDI- BMC1 -242			

TYPE A:

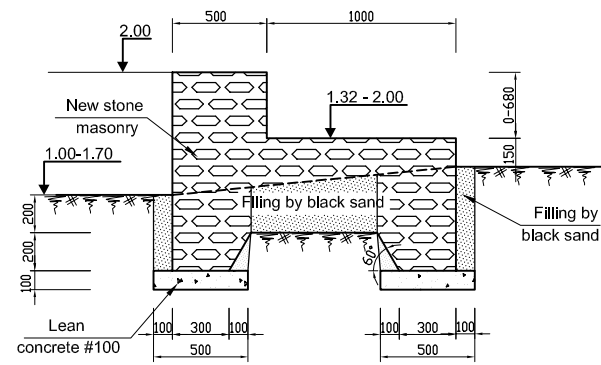

TYPE D:
(The existing improved and new dike)

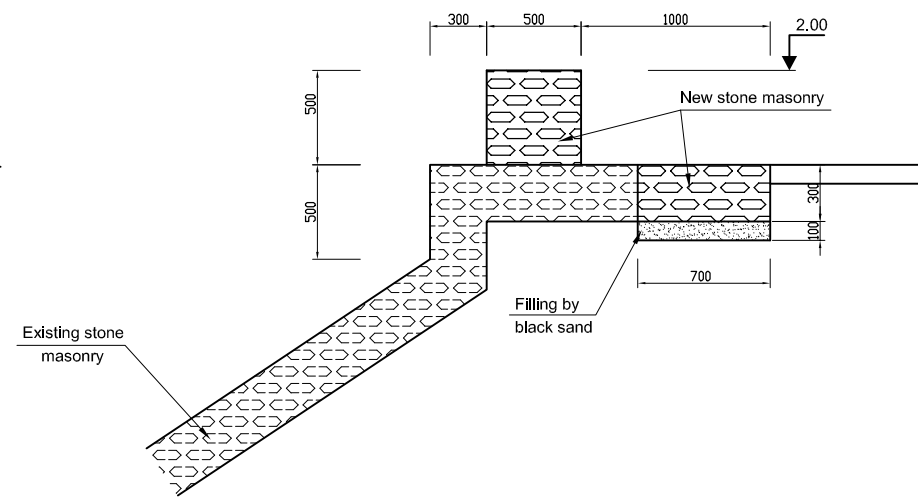

TYPE G:

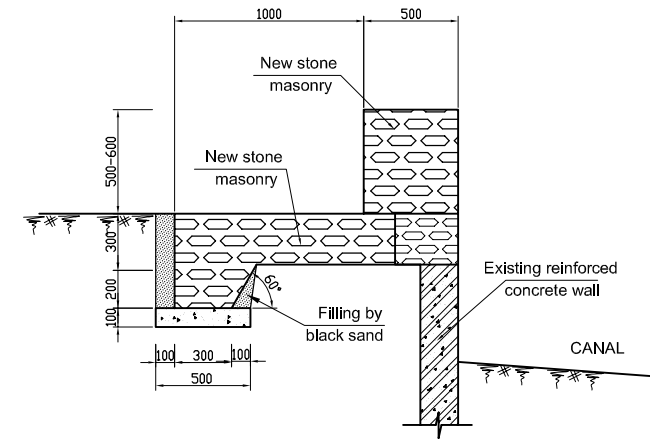

TYPE B:

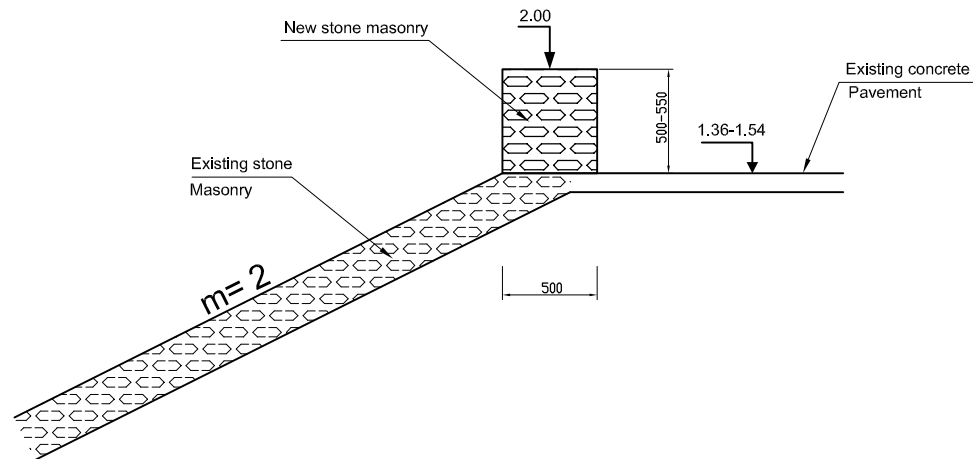

TYPE E:

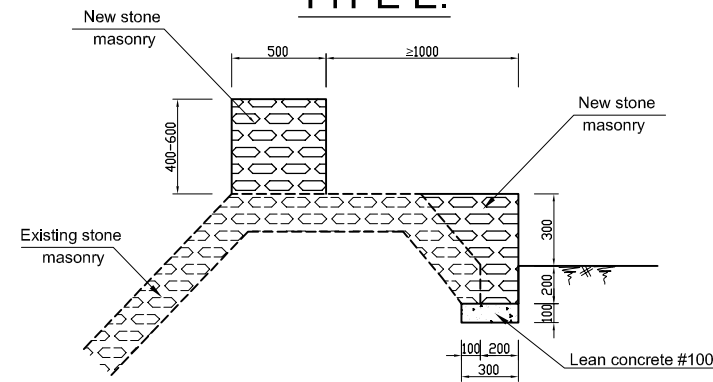

PIER

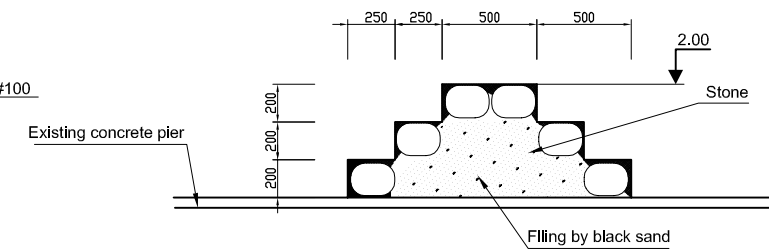

TYPE C:

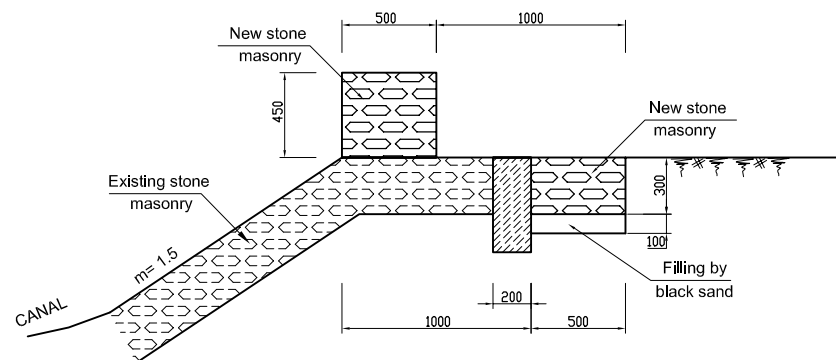

TYPE F:

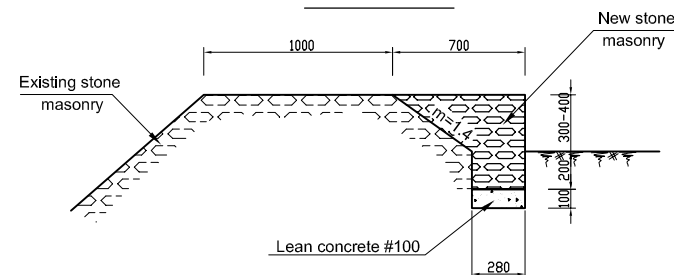

TYPE	VOLUME OF (PER 1m long) (Unit: m3)			
	Excavation	Sandy soil back filling	Leveling concrete	Stone Masonry
A	0.77	0.29	0.10	0.870
B				0.275
C	0.20	0.05		0.375
D	0.28	0.07		0.460
E	0.09		0.03	0.480
F	0.084		0.028	0.203
G	0.51	0.06	0.05	0.700
PIER		0.30		0.300

NO.	DATE	DESCRIPTIONS	BY	APRO.
-----	------	--------------	----	-------

REVISIONS

PROJECT MANAGEMENT UNIT FOR
HO CHI MINH CITY
WATER ENVIRONMENT IMPROVEMENT

THE DETAILED DESIGN STUDY ON HO CHI MINH CITY
WATER ENVIRONMENT IMPROVEMENT PROJECT
IN THE SOCIALIST REPUBLIC OF VIET NAM

PACKAGE B
PUMP DRAINAGE IMPROVEMENT
BEN ME COC (1) AREA

DETAIL OF TEMPORARY DIKE

SCALE : 1 : 20

JICA JAPAN INTERNATIONAL COOPERATION
AGENCY (JICA)

PACIFIC CONSULTANTS INTERNATIONAL

DESIGNED TOKUMASU TOSHIAKI	CHECKED KONDO MASAMI
-------------------------------	-------------------------

DATE : JUNE 2001 DWG. No.PB -PDI- BMC1 -243

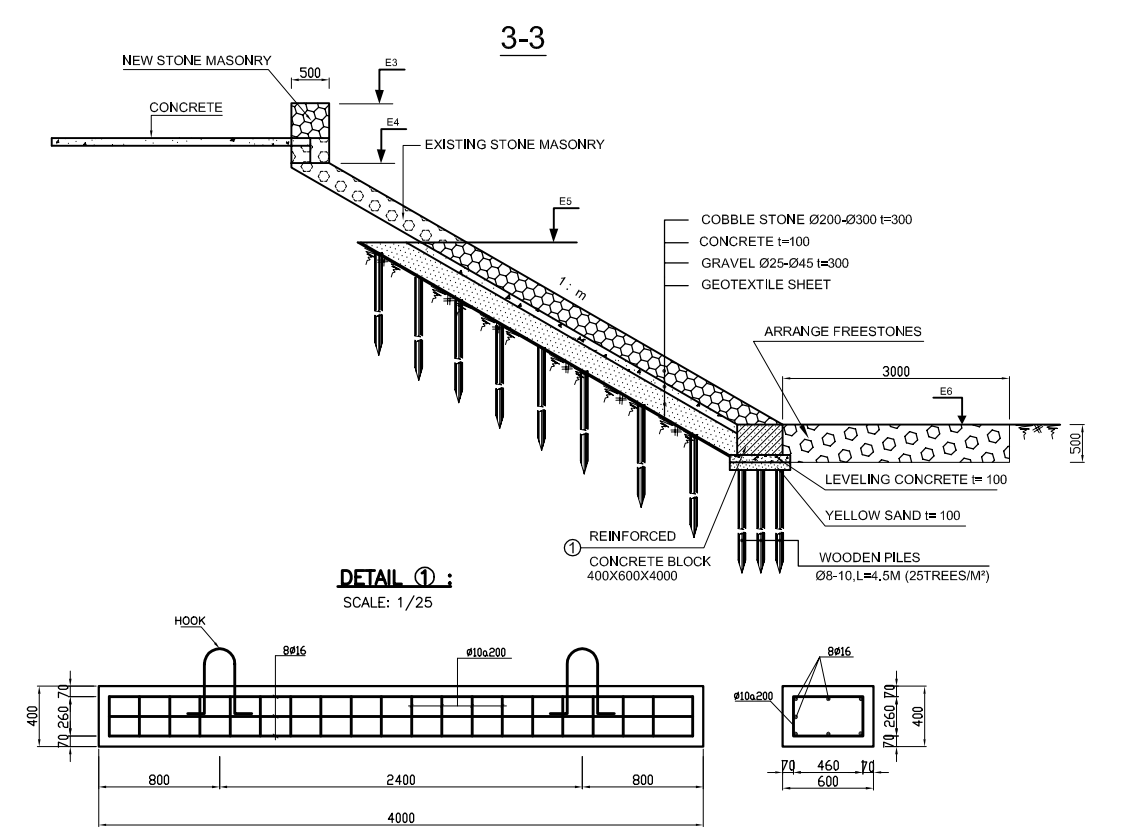
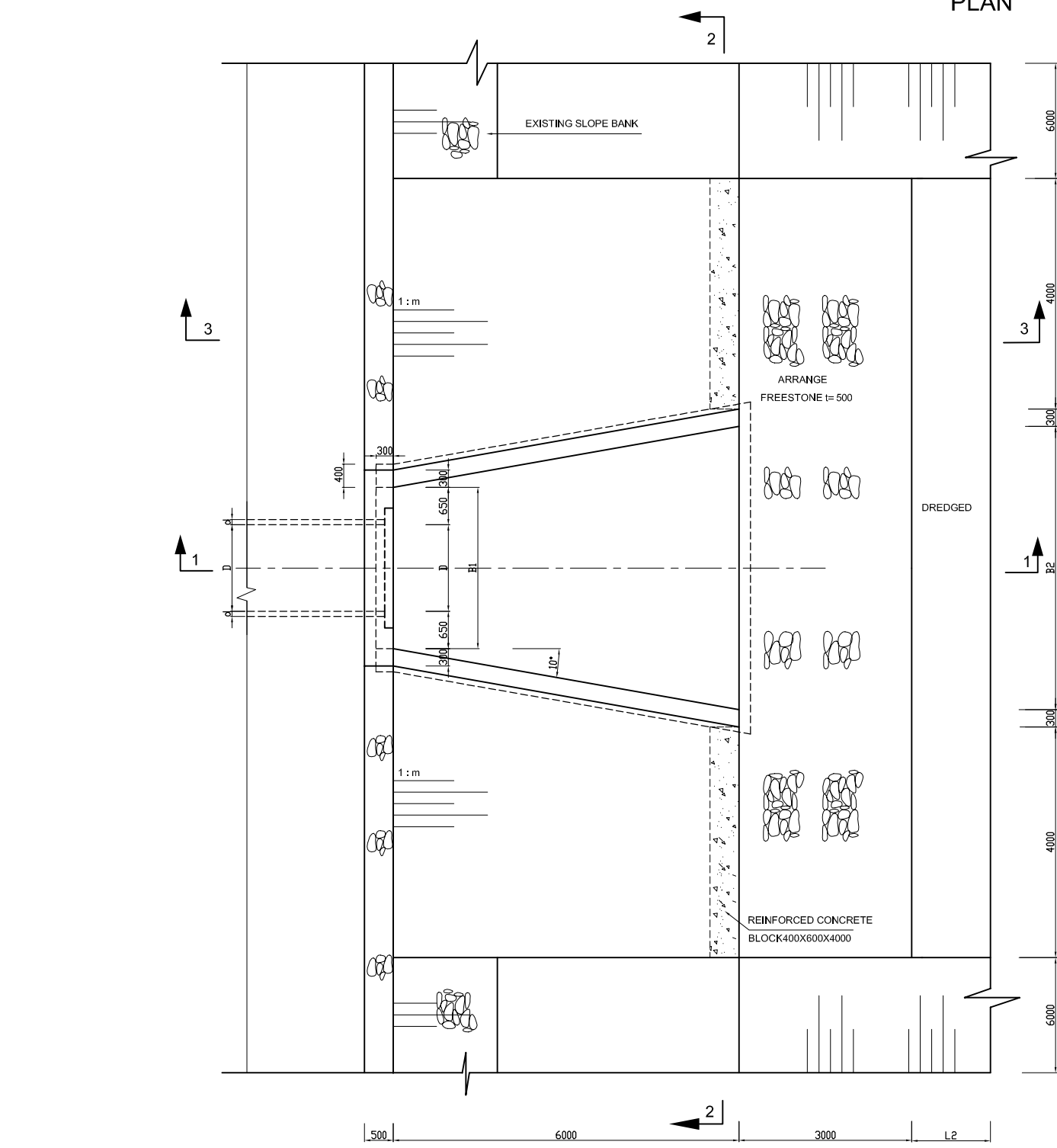
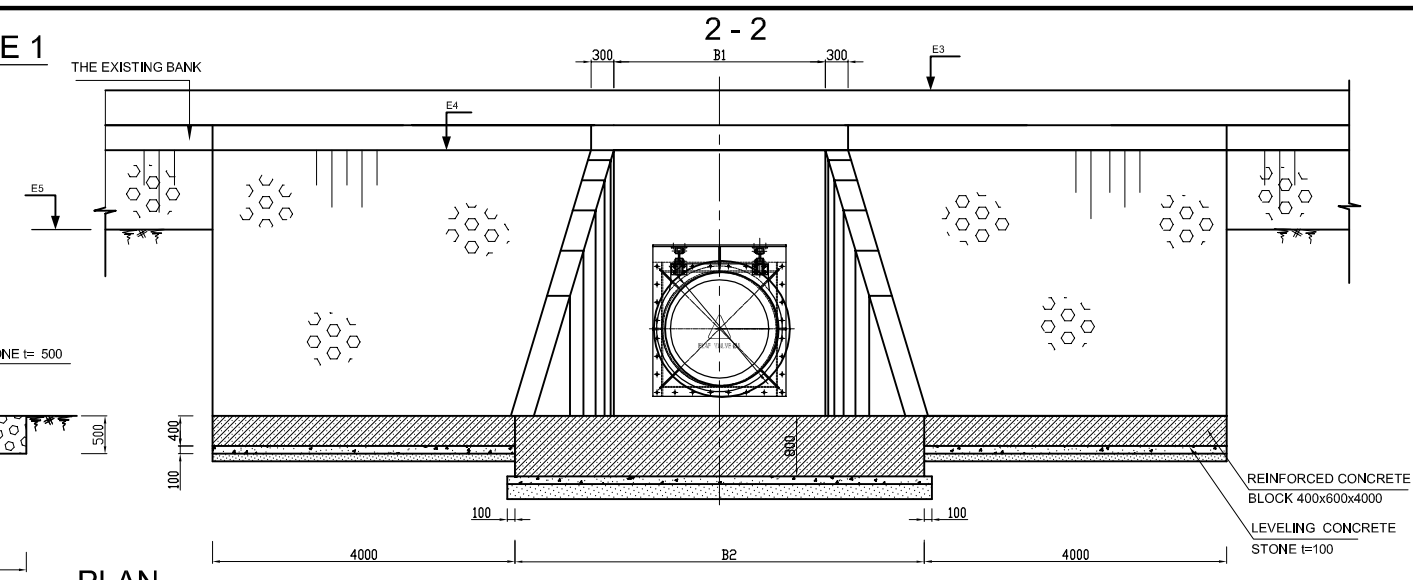
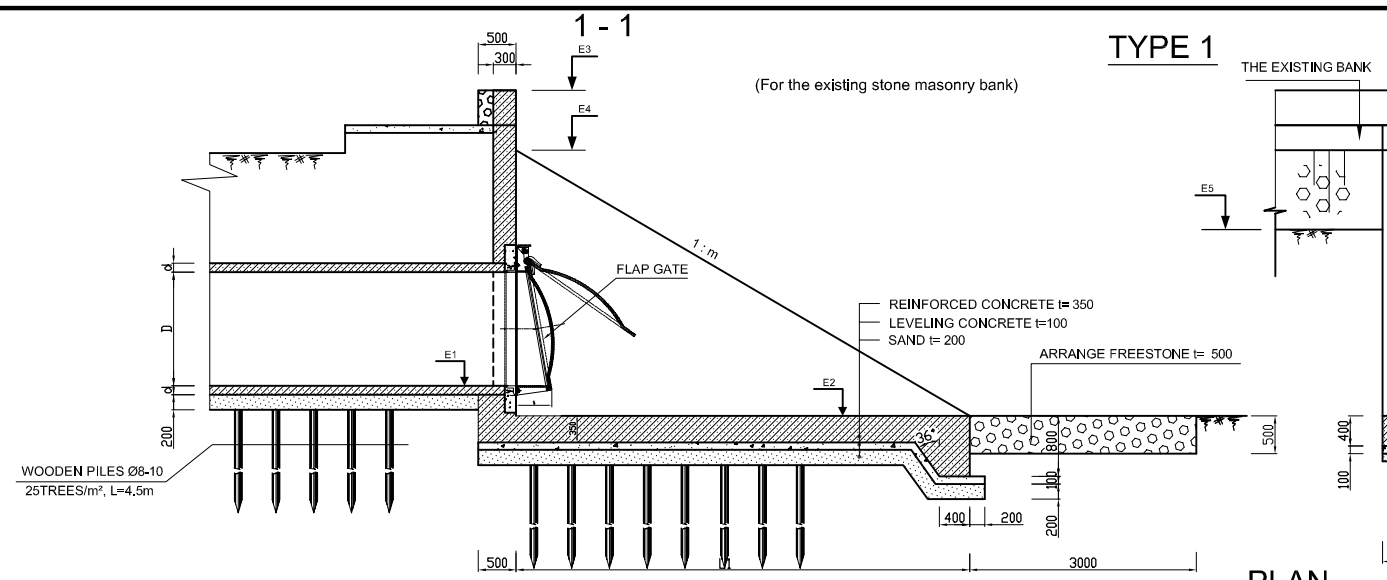

BEN ME COC 1

No	DIAMETER	POSITION	ELEVATION						m	H	B1	B2	L1	L2
			E1	E2	E3	E4	E5	E6						
1	1000	W2-0+420.5	-1.200	-1.600	2.000	1.550	-1.350	-1.600	1.5	3.60	2.30	3.90	4.70	3.50
2	1200	W2-0+851.8	-1.915	-2.315	2.000	1.550	-1.350	-2.315	1.5	4.30	2.50	4.50	5.80	4.40
3	1500	E3-0+623	-1.904	-2.304	2.000	1.210	0.160	-2.304	1.7	4.30	2.80	5.00	6.00	10.50
4	900	E3-0+320.15	-1.285	-1.685	2.000	1.440	0.520	-1.685	2.0	3.70	2.20	4.40	6.30	0.00
5	1000	E1-0+221	-0.624	-1.024	2.000	1.040	-0.370	-1.024	2.5	3.00	2.30	4.10	5.20	0.00
6	1200	E1-0+003	-1.292	-1.692	2.000	1.490	0.740	-1.692	1.06	3.70	2.50	3.70	3.40	1.60
7	1500	E1-0+318	-1.903	-2.303	2.200	2.200	0.580	-2.303	1.6	4.50	2.80	5.40	7.20	7.80
8	900	W1-1+335	-1.925	-2.325	2.200	2.200	0.580	-2.325	1.6	4.50	3.10	5.70	7.20	15.00

LEGEND:

- E1: INVERT ELEVATION OF SEWER PIPE
- E2: ELEVATION OF OUTLET FLOOR
- E3: TOP ELEVATION OF OUTLET VERTICAL WALL
- E4: TOP ELEVATION OF OUTLET WING WALL
- E5: TOP ELEVATION OF ADDITIONAL STONE MASONRY
- E6: FOOT ELEVATION OF ADDITIONAL STONE MASONRY

NOTE:

DETAILS OF FLAP GATE REFERS TO PB - PDI - BMC1 - 405

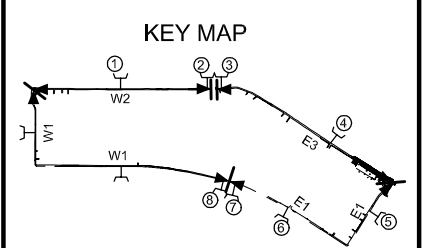

NO.	DATE	DESCRIPTIONS	BY	APRO.
REVISIONS				
PROJECT MANAGEMENT UNIT FOR HO CHI MINH CITY WATER ENVIRONMENT IMPROVEMENT				
THE DETAILED DESIGN STUDY ON HO CHI MINH CITY WATER ENVIRONMENT IMPROVEMENT PROJECT IN THE SOCIALIST REPUBLIC OF VIET NAM				
PACKAGE B PUMP DRAINAGE IMPROVEMENT BEN ME COC(1) AREA				
TYPICAL PLAN AND SECTION OF SEWER OUTLET (TYPE 1)				
SCALE : 1 : 50				
JAPAN INTERNATIONAL COOPERATION AGENCY (JICA) PACIFIC CONSULTANTS INTERNATIONAL				
DESIGNED TOKUMASU TOSHIAKI		CHECKED KONDO MASAMI		
DATE : JUNE 2001		DWG. No. PB - PDI - BMC1-244		

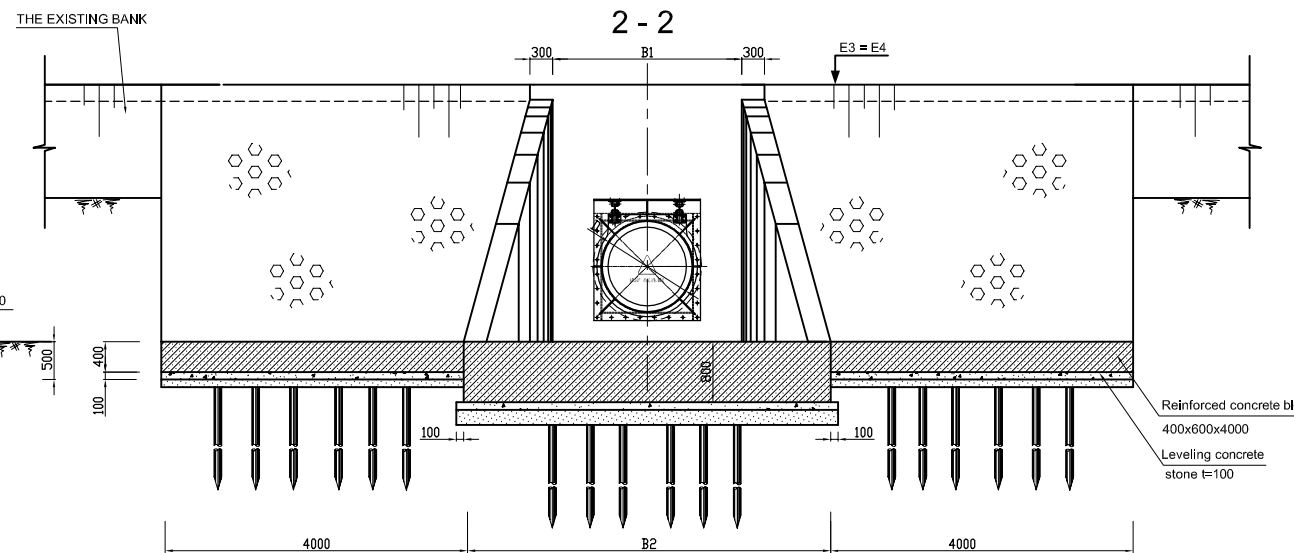
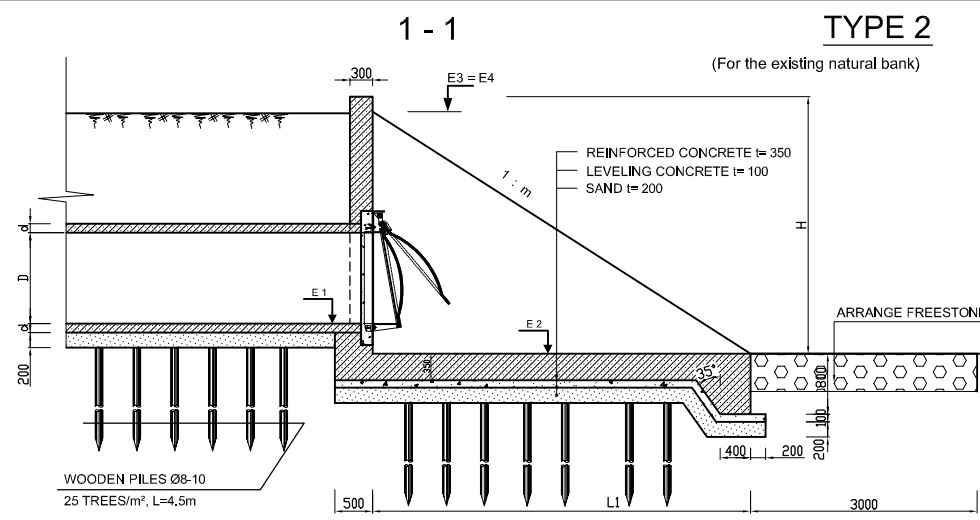

PLAN

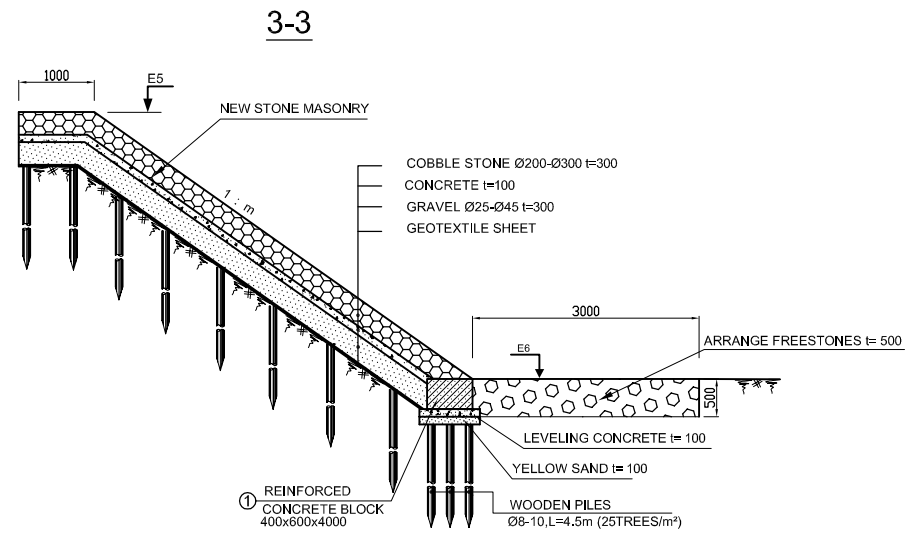
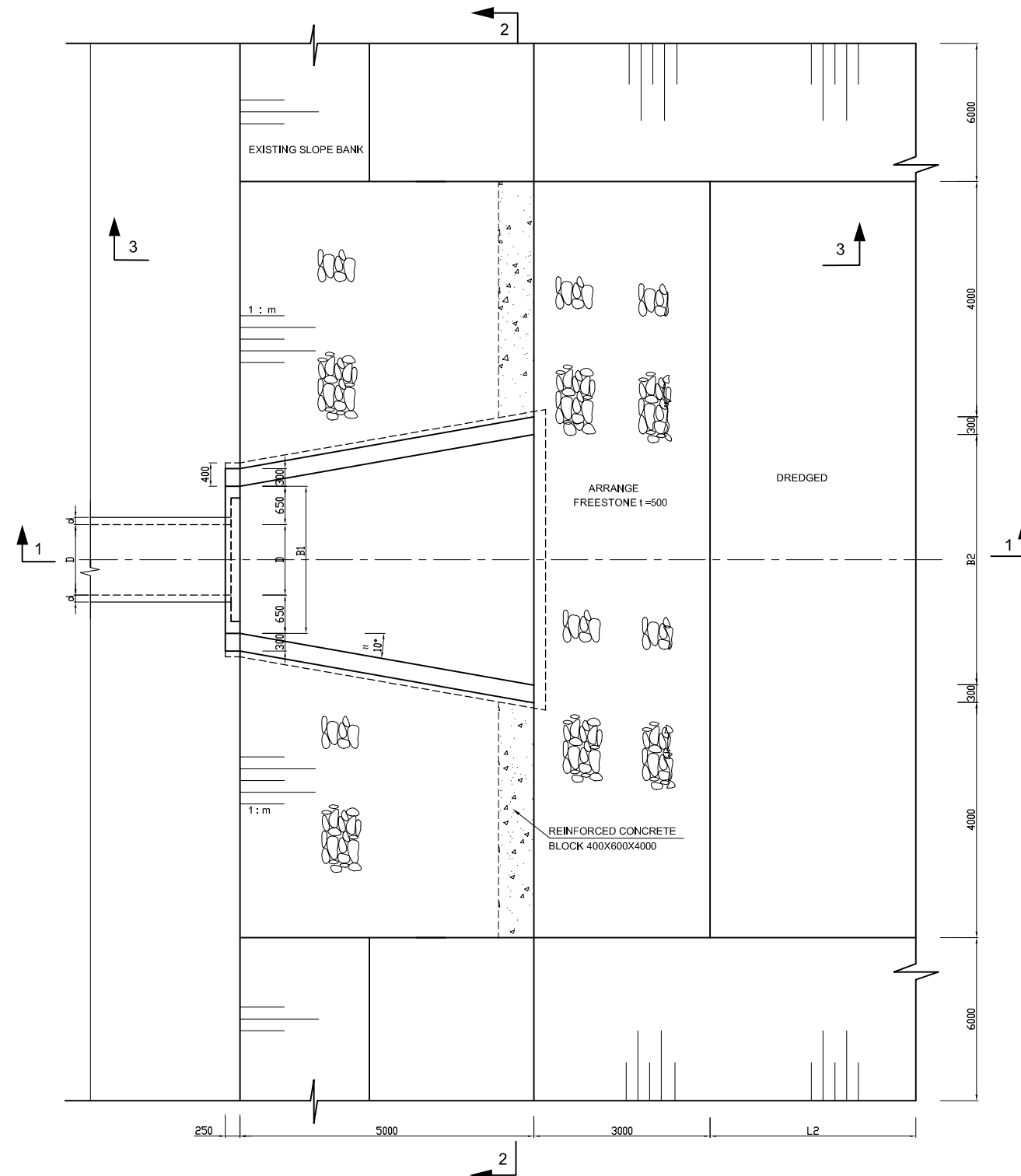

DETAIL ① :
SCALE: 1/25

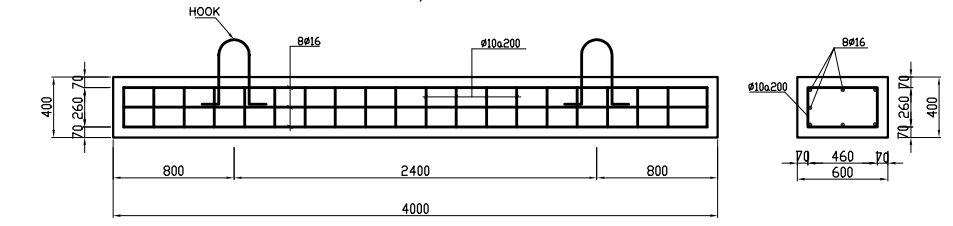

BEN ME COC 1

No	DIAMETER	POSITION	ELEVATION						m	H (m)	B1 (m)	B2 (m)	L1 (m)	L2 (m)
			E1	E2	E3	E4	E5	E6						
9	1200	W1-0+879	-1.702	-2.102	1.100	1.100	1.300	-2.102	1.5	3.40	2.50	4.30	5.10	6.00
10	900	W1-0+229.5	-0.475	-0.875	1.100	1.100	1.300	-0.875	1.5	2.20	2.20	3.40	3.30	8.00

LEGEND:

- E1: INVERT ELEVATION OF SEWER PIPE
- E2: ELEVATION OF OUTLET FLOOR
- E3: TOP ELEVATION OF OUTLET VERTICAL WALL
- E4: TOP ELEVATION OF OUTLET WING WALL
- E5: TOP ELEVATION OF ADDITIONAL STONE MASONRY
- E6: FOOT ELEVATION OF ADDITIONAL STONE MASONRY

NOTE:
DETAILS OF FLAP GATE REFERS TO PB - PDI - BMC1 - 405

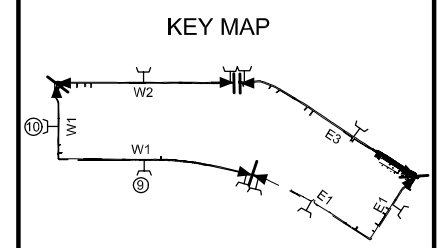

NO.	DATE	DESCRIPTIONS	BY	APRO.

REVISIONS

PROJECT MANAGEMENT UNIT FOR
HO CHI MINH CITY
WATER ENVIRONMENT IMPROVEMENT

THE DETAILED DESIGN STUDY ON HO CHI MINH CITY
WATER ENVIRONMENT IMPROVEMENT PROJECT
IN THE SOCIALIST REPUBLIC OF VIET NAM

PACKAGE B
PUMP DRAINAGE IMPROVEMENT
BEN ME COC(1) AREA

TYPICAL PLAN AND SECTION
OF SEWER OUTLET (TYPE 2)

SCALE : 1 : 50

JICA JAPAN INTERNATIONAL COOPERATION AGENCY (JICA)

PACIFIC CONSULTANTS INTERNATIONAL

DESIGNED: TOKUMASU TOSHIAKI
CHECKED: KONDO MASAMI

DATE : JUNE 2001
DWG. No. PB - PDI - BMC1-245

SECTION C-C

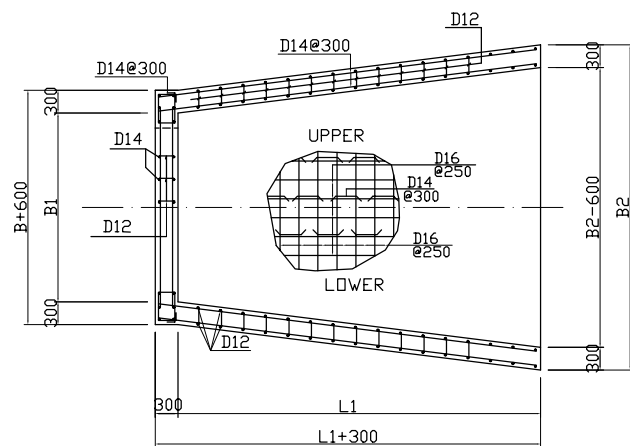

SECTION A-A

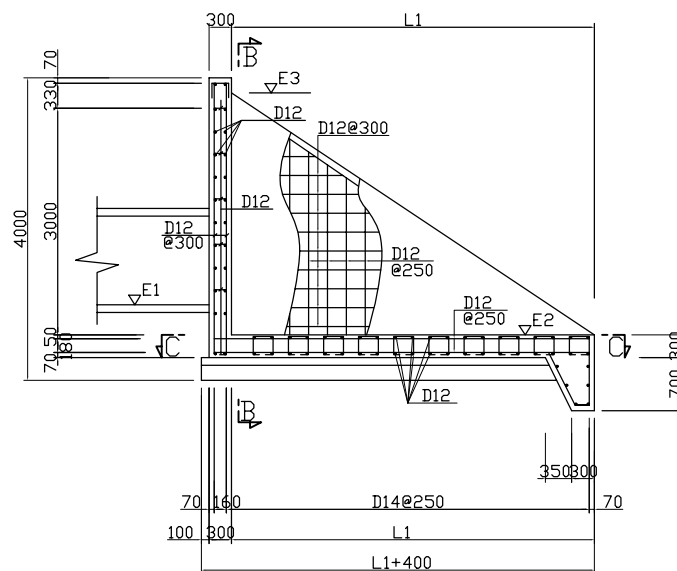

SECTION B-B

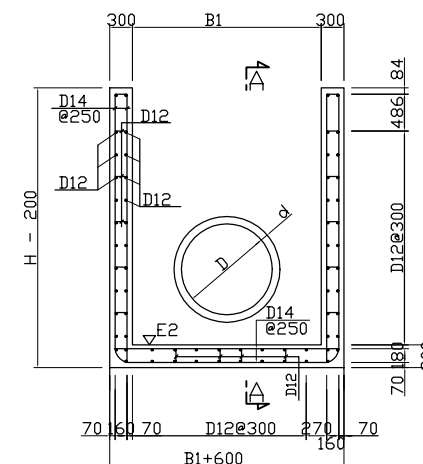

LEGEND

BEN ME COC 1										
No	DIAMETER	POSITION	ELEVATION			ELEVATION (m)	B1 (m)	B2 (m)	L1 (m)	L2 (m)
			E1	E2	E3					
9	1200	W1-0+879	-1.702	-2.102	1.300	3.40	2.50	4.30	5.10	6.00
10	900	W1-0+229.5	-0.475	-0.875	1.300	2.20	2.20	3.40	3.30	8.00
BEN ME COC 2										
1	100	N1-0+427.5	-0.967	-1.367	2.000	3.40	2.30	3.50	4.40	5.20
2	1500	N1-0+876	-1.964	-2.364	2.000	4.40	2.80	4.80	5.90	11.00
3	1500	N1-0+900	-1.962	-2.362	2.000	4.40	2.80	4.80	5.90	10.00
4	1200	N1-0+720	-1.470	-1.870	2.000	3.90	2.50	4.30	5.10	6.00
5	900	N1-0+205	-0.617	-1.017	2.000	3.00	2.20	3.60	3.90	12.00

LEGEND

E1: INVERT ELEVATION OF SEWER PIPE
 E2: ELEVATION OF OUTLET FLOOR
 E3: TOP ELEVATION OF OUTLET VERTICAL WALL
 E4: TOP ELEVATION OF OUTLET WING WALL
 E5: TOP ELEVATION OF ADDITIONAL STONE MASONRY
 E6: FOOT ELEVATION OF ADDITIONAL STONE MASONRY

NO.	DATE	DESCRIPTIONS	BY	APRO.
-----	------	--------------	----	-------

REVISIONS

PROJECT MANAGEMENT UNIT FOR
 HO CHI MINH CITY
 WATER ENVIRONMENT IMPROVEMENT

THE DETAILED DESIGN STUDY ON HO CHI MINH CITY
 WATER ENVIRONMENT IMPROVEMENT PROJECT
 IN THE SOCIALIST REPUBLIC OF VIET NAM

PACKAGE B
 POMP DRAINAGE IMPROVEMENT
 BEN ME COC (1) - (2) AREA

TYPICAL BAR ARRANGEMENT
 OF SEWER OUT LET

SCALE : 1/50

JICA JAPAN INTERNATIONAL COOPERATION
 AGENCY (JICA)

PACIFIC CONSULTANTS INTERNATIONAL

DESIGNED TOKUMASU TOSHIAKI
 CHECKED KONDO MASAMI

DATE : JUNE 2001 DWG. No. PB - PD1 - BMC1 - 246

TYPE 1 S = 1:40
Ø300 - Ø600

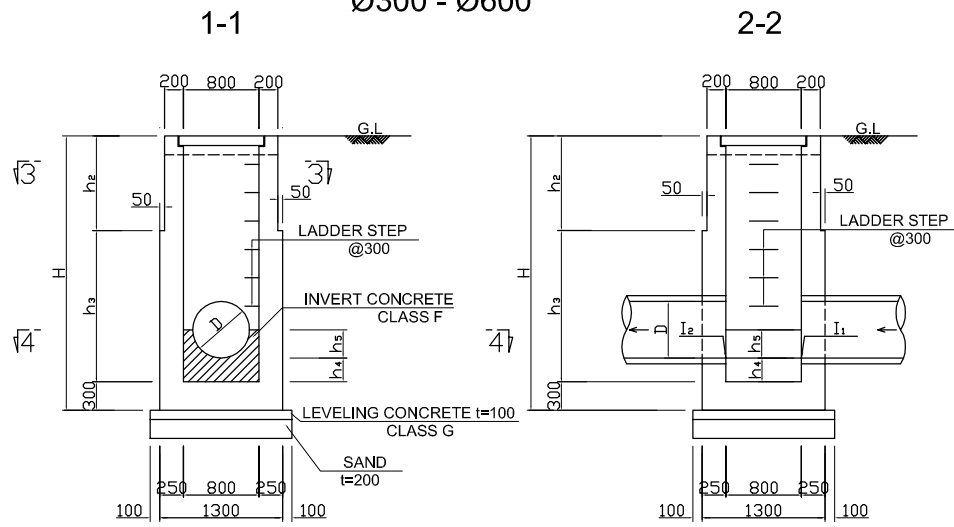

TYPE 2 S = 1:40
Ø700 - Ø1000

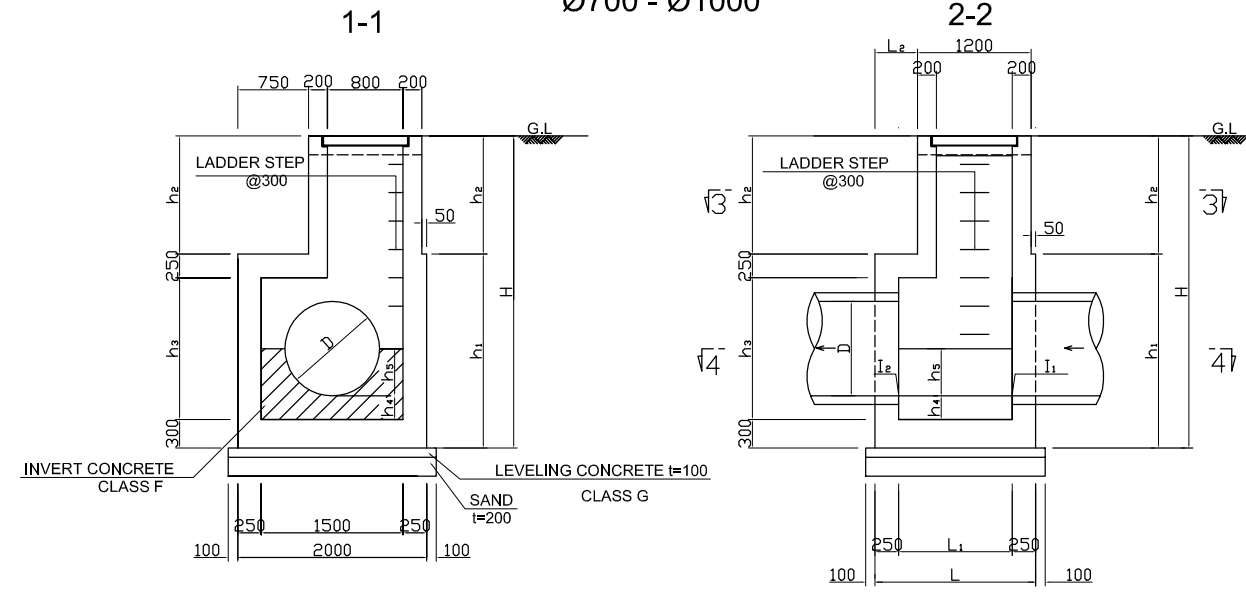

When $H \leq 2850$, $h_2 = 300$
When $H \geq 2850$, $h_2 = 2000$

3-3

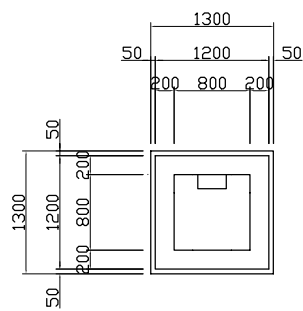

4-4

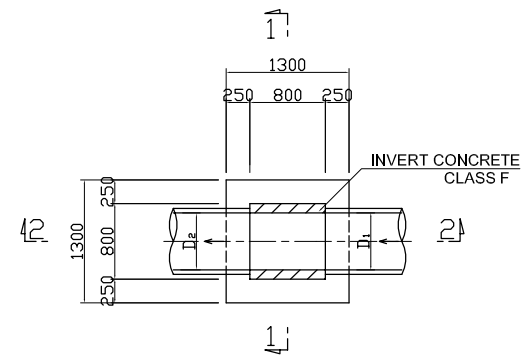

3-3

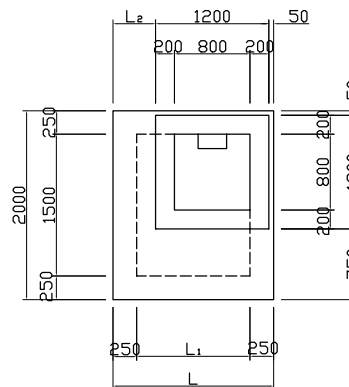

4-4

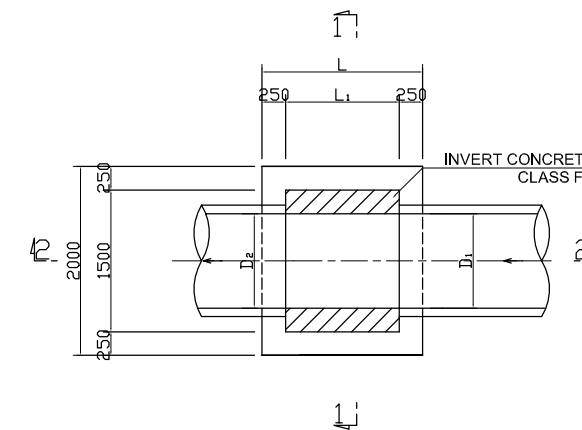

CONNECTION TYPE

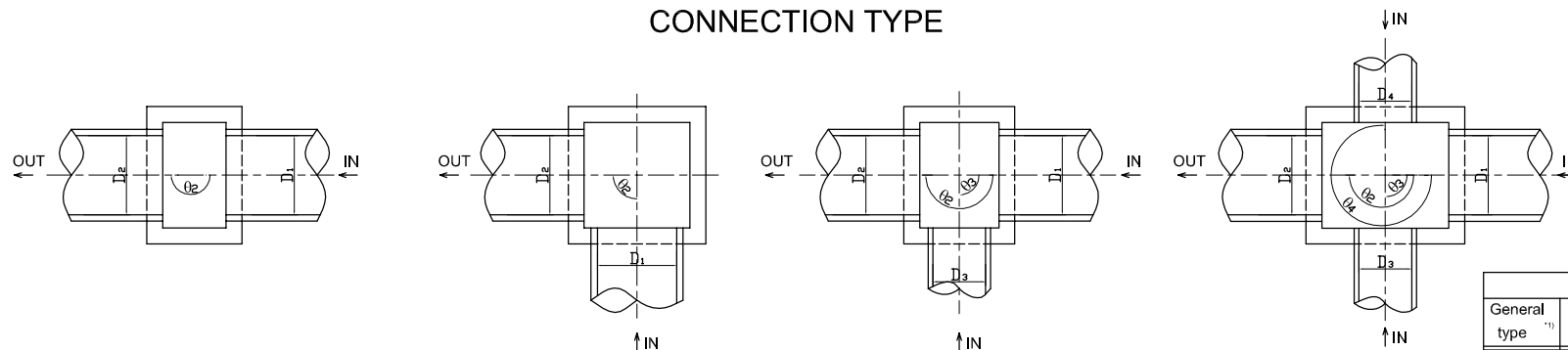

TYPE A

TYPE B

TYPE C

TYPE D

TYPE OF MANHOLE

General type ^{*)}	Connection type	Connection pipe ^{*)}	Diameter (mm)		Dimension (m)			Number of Manhole
			Main pipe (D ₁ , D ₂)	Connecting pipe (D ₁ , D ₂)	L	L ₁	L ₂	
1	A, B, C	-	Ø300-Ø600	Ø300-Ø600	-	-	-	5
	A	-	Ø700-Ø1000	-	1,700	1,200	450	0
	B	-		-	2,000	1,500	750	3
2	C	1	Ø700-Ø1000	Ø300-Ø600	1,700	1,200	450	19
		2		Ø700-Ø1000	2,000	1,500	750	0
	D	1		Ø300-Ø600	2,500	2,000	1,250	18
		2		Ø700-Ø1000	2,900	2,400	1,650	3

This table is applied at a depth of up to 2.5m for Type 1 and 5.0m for Type 2

Note:

*1) General type of Manhole type is categorized in diameter of Main pipe, D₁ and D₂.

*2) Connection pipe of Manhole type is categorized in a diameter of connection pipe.

NO.	DATE	DESCRIPTIONS	BY	APRO.

REVISIONS

PROJECT MANAGEMENT UNIT FOR
HO CHI MINH CITY
WATER ENVIRONMENT IMPROVEMENT

THE DETAILED DESIGN ON HO CHI MINH CITY
WATER ENVIRONMENT IMPROVEMENT PROJECT
IN THE SOCIALIST REPUBLIC OF VIET NAM

PACKAGE B
PUMP DRAINAGE IMPROVEMENT
BEN ME COC(1) AREA
TYPICAL PLAN AND SECTION
OF MANHOLE (1)

SCALE : 1/40

JICA JAPAN INTERNATIONAL COOPERATION
AGENCY (JICA)

PACIFIC CONSULTANTS INTERNATIONAL

DESIGNED
TOKUMASU TOSHIKI

CHECKED
KONDO MASAMI

DATE : JUNE 2001 DWG. No. PB - PDI - BMC1 - 247

