

## ***FIGURES***

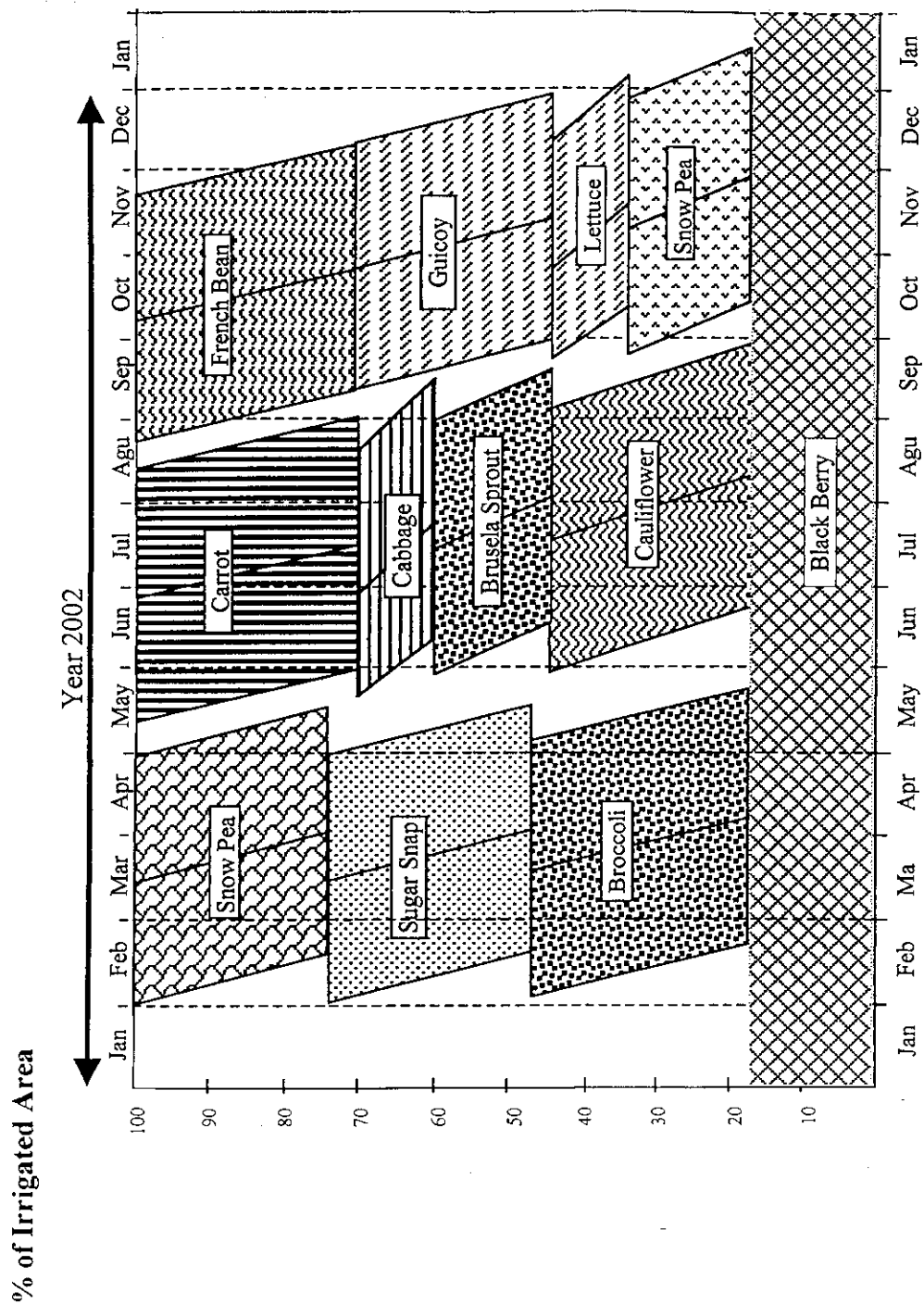

THE MASTER PLAN STUDY ON SUSTAINABLE RURAL DEVELOPMENT FOR THE REDUCTION OF POVERTY IN THE CENTRAL HIGHLAND REGION OF THE REPUBLIC OF GUATEMALA

Japan International Cooperation Agency (JICA)

**Figure 8.3.1 (1)**  
**Proposed Cropping Pattern for**  
**Xeatzán Bajo Irrigation Area**

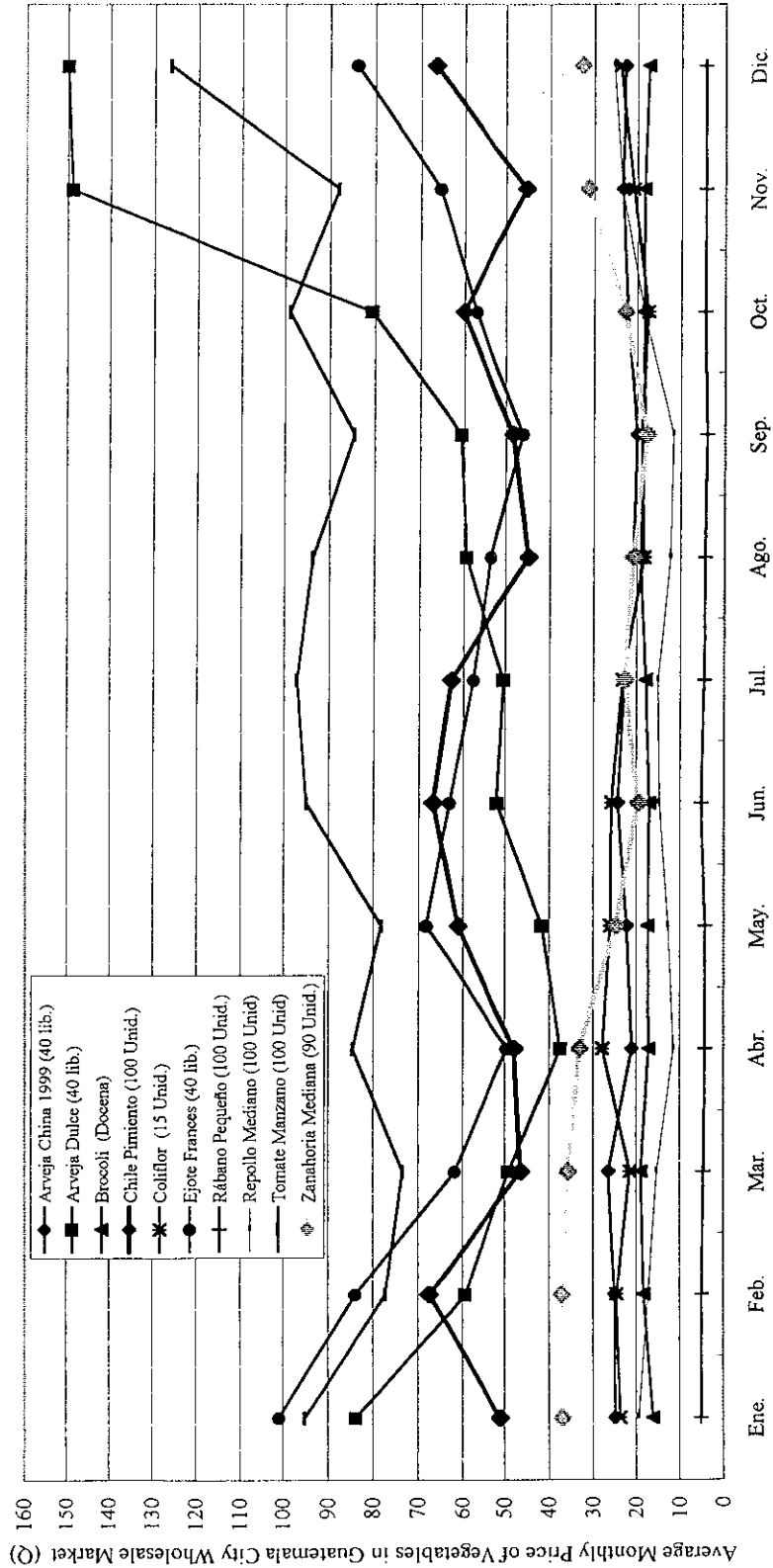

THE MASTER PLAN STUDY ON SUSTAINABLE RURAL DEVELOPMENT FOR THE REDUCTION OF POVERTY IN THE CENTRAL HIGHLAND REGION OF THE REPUBLIC OF GUATEMALA

Japan International Cooperation Agency (JICA)

Figure 8.3.1 (2)

Monthly Variation of Vegetable Prices at Guatemala City

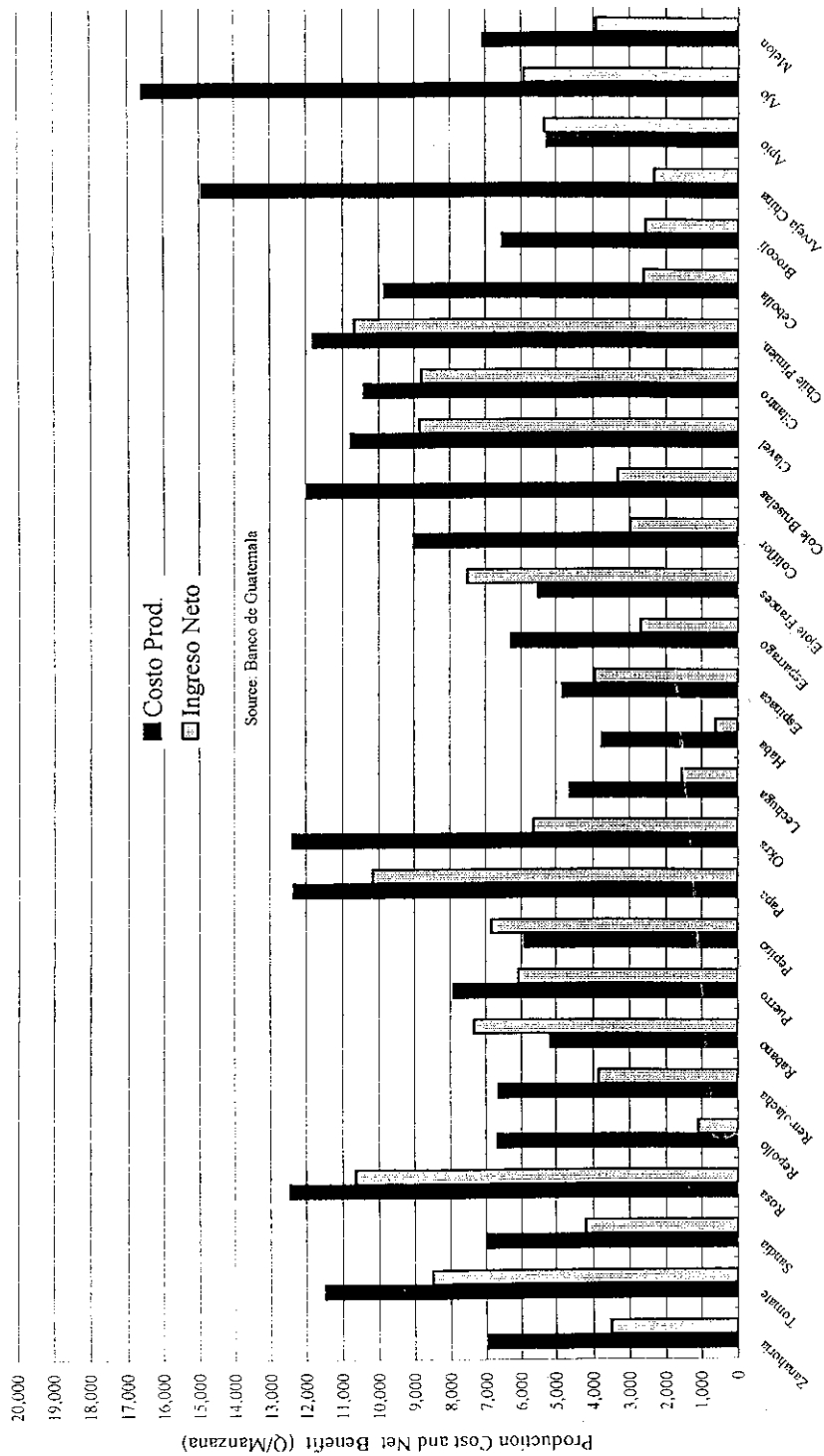

THE MASTER PLAN STUDY ON SUSTAINABLE RURAL DEVELOPMENT FOR THE REDUCTION OF POVERTY IN THE CENTRAL HIGHLAND REGION OF THE REPUBLIC OF GUATEMALA

Japan International Cooperation Agency (JICA)

Figure 8.3.1 (3)

Production Cost an Net Benefit of Different Vegetable Crops

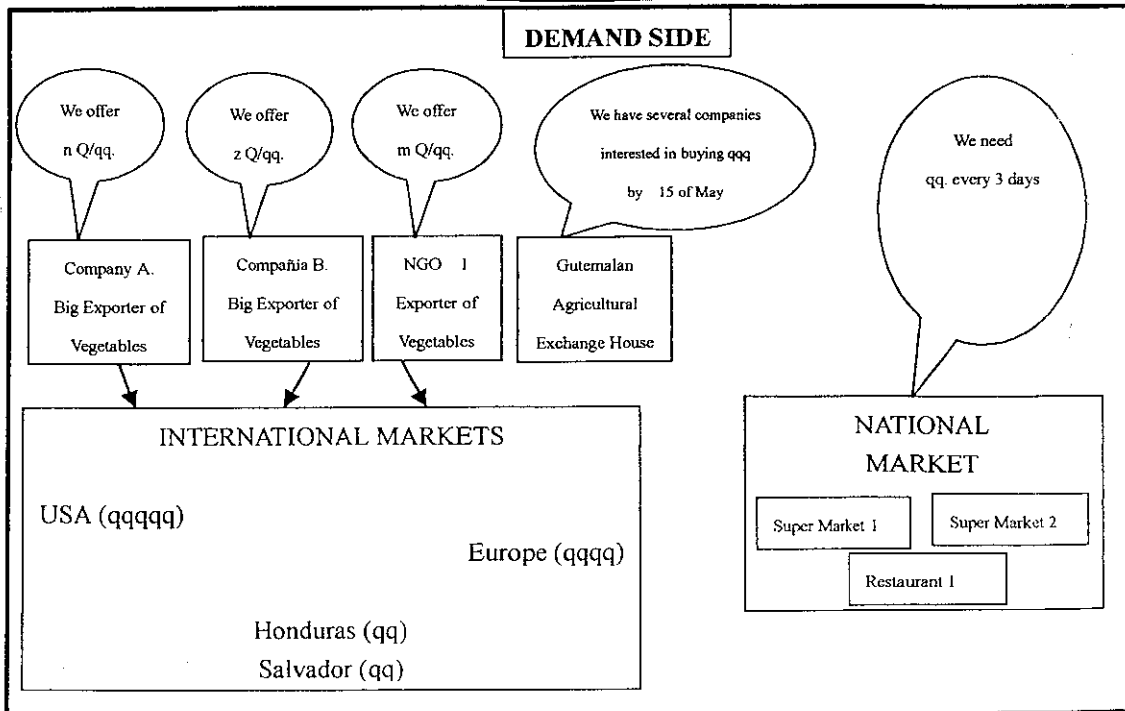
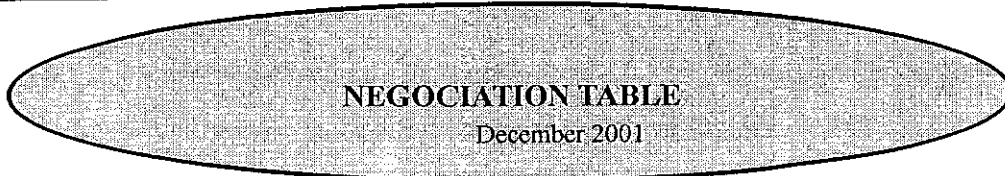
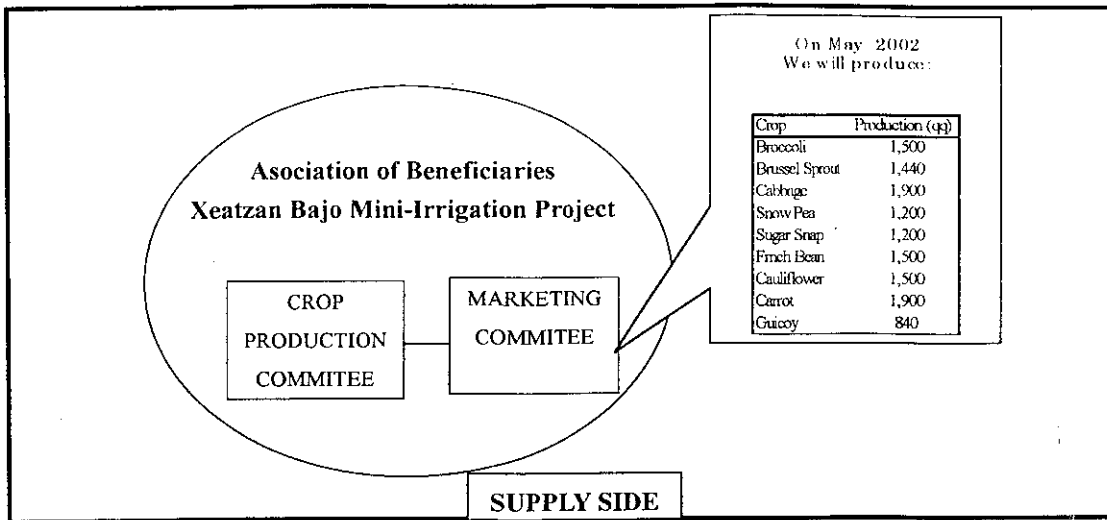

THE MASTER PLAN STUDY ON SUSTAINABLE RURAL DEVELOPMENT FOR THE REDUCTION OF POVERTY IN THE CENTRAL HIGHLAND REGION OF THE REPUBLIC OF GUATEMALA

Japan International Cooperation Agency (JICA)

**Figure 8.3.1 (4)**  
**Alternative Market Channels for Selling Vegetables of Xeatzán Bajo**

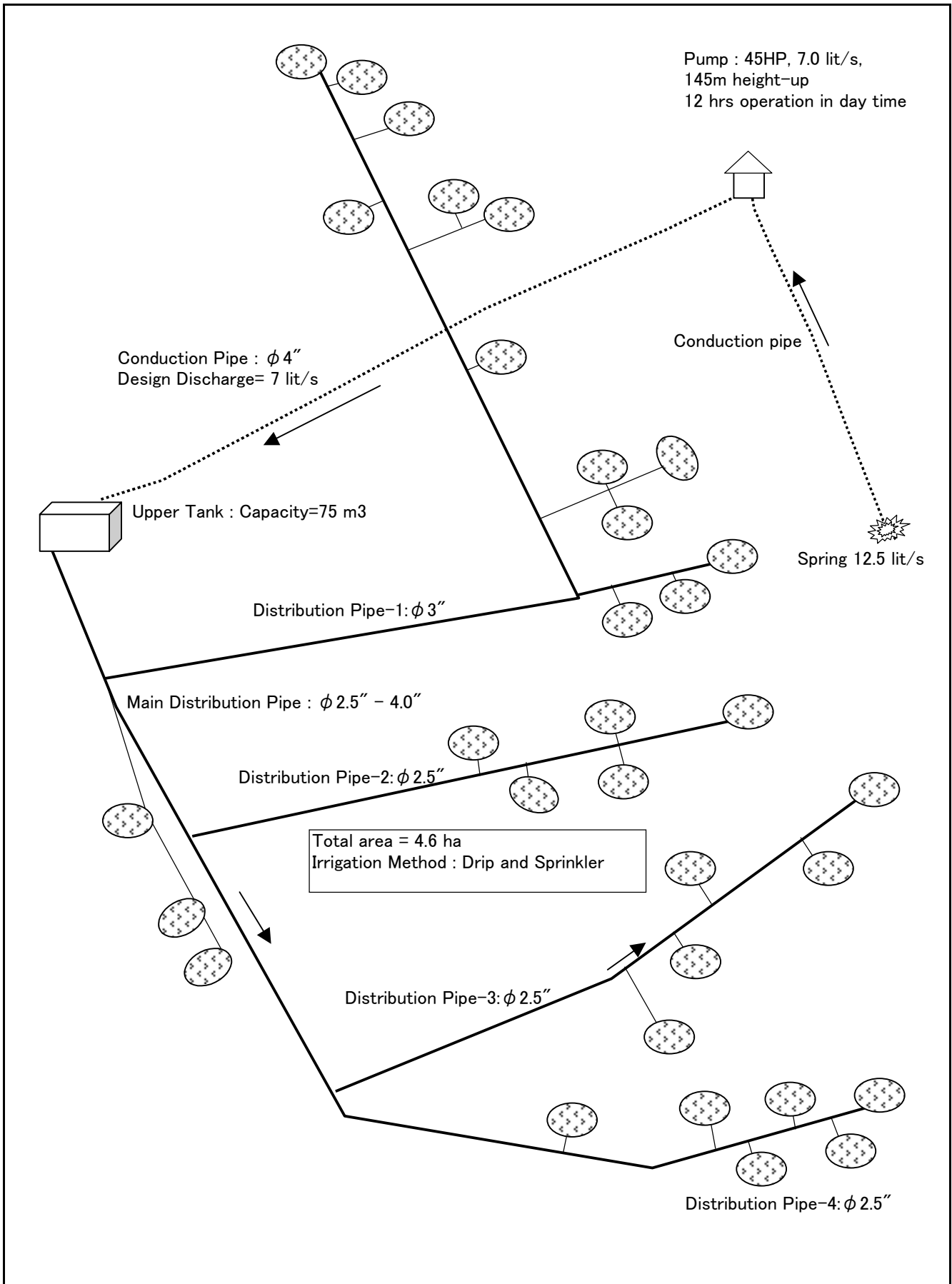

THE MASTER PLAN STUDY ON SUSTAINABLE RURAL  
DEVELOPMENT FOR THE REDUCTION OF POVERTY  
IN THE CENTRAL HIGHLAND REGION  
OF THE REPUBLIC OF GUATEMALA

Japan International Cooperation Agency (JICA)

**Figure 8.3.1 (5)**  
**General Feature of Irrigation**  
**System**  
**in Yeatzan Rain**

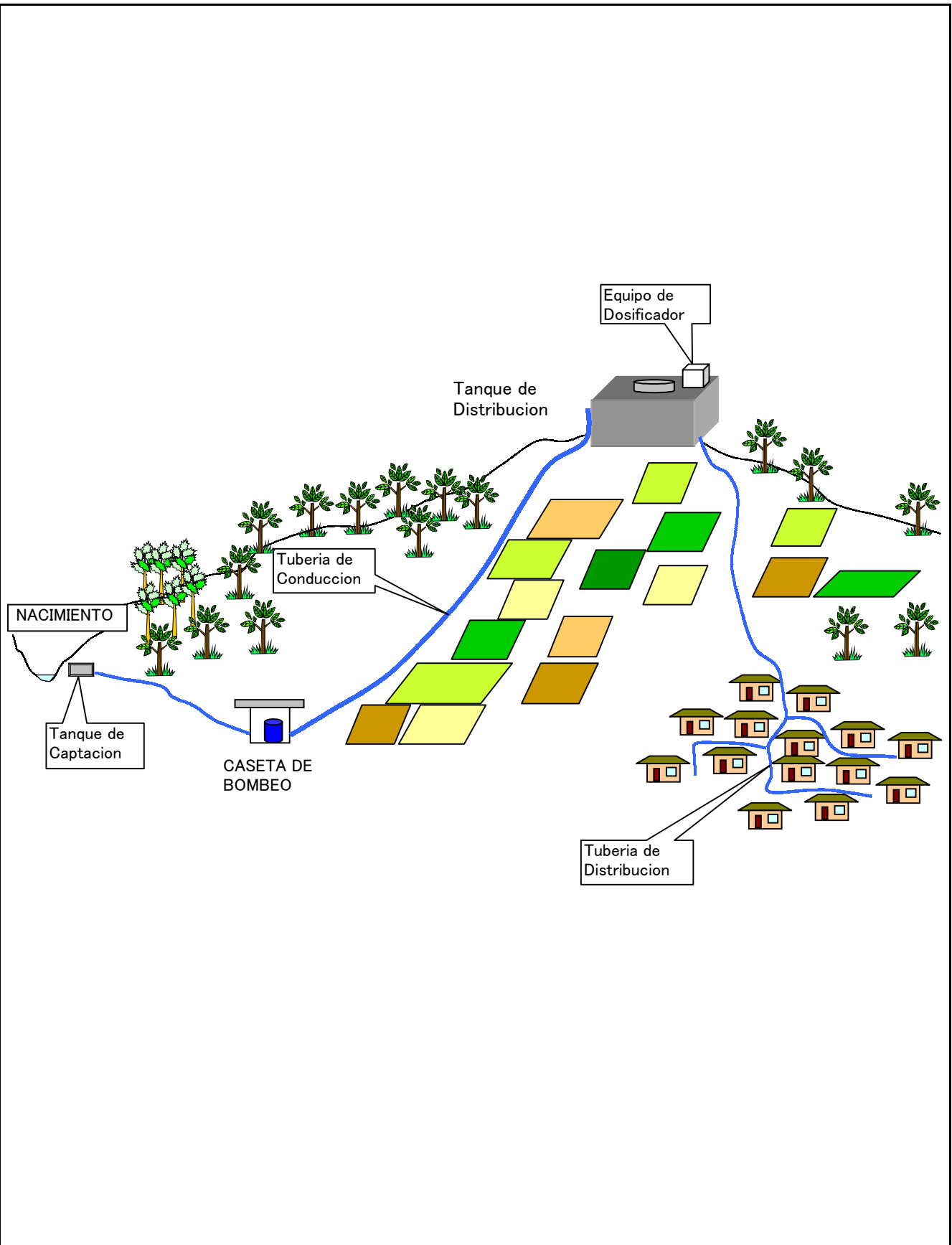

THE MASTER PLAN STUDY ON SUSTAINABLE RURAL DEVELOPMENT FOR THE REDUCTION OF POVERTY IN THE CENTRAL HIGHLAND REGION OF THE REPUBLIC OF GUATEMALA

Japan International Cooperation Agency (JICA)

**Figure 8.3.3 (1)**  
**Drinking Water Quality Improvement Plan**  
**Outline of Drinking Water Supply System**  
**Xeatzan Bajo, Patzun, Chimaltenango**

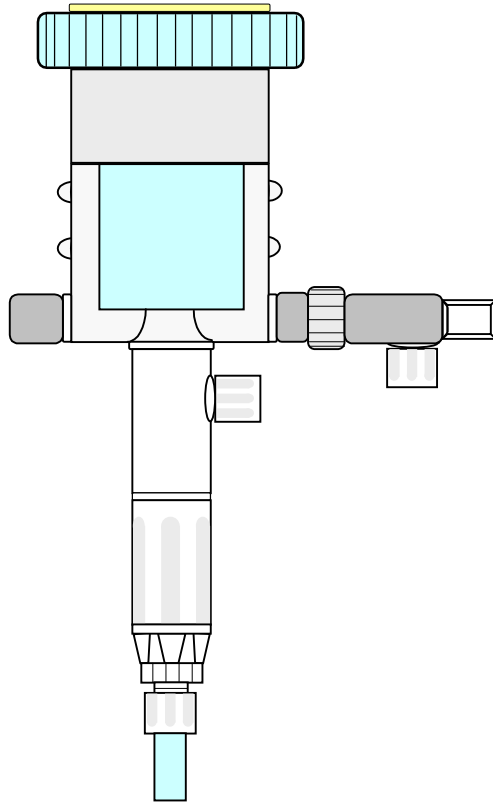

**CARACTERISTICAS:**

Proporcional sin Electricidad

Fuente de energia : la presion del agua

Valores minimo y maximo del caudal del agua : 20 – 1500 l/h

Presion de funcionamiento : 0.5 a 5 Bar (presion de entrada)

Tempertura de funcionamiento : max.40°C–min. proteger de las heladas.

THE MASTER PLAN STUDY ON SUSTAINABLE RURAL  
DEVELOPMENT FOR THE REDUCTION OF POVERTY  
IN THE CENTRAL HIGHLAND REGION  
OF THE REPUBLIC OF GUATEMALA

Japan International Cooperation Agency (JICA)

**Figure 8.3.3 (2)**

**Drinking Water Quality Improvement  
Hypochlorinate dosing**



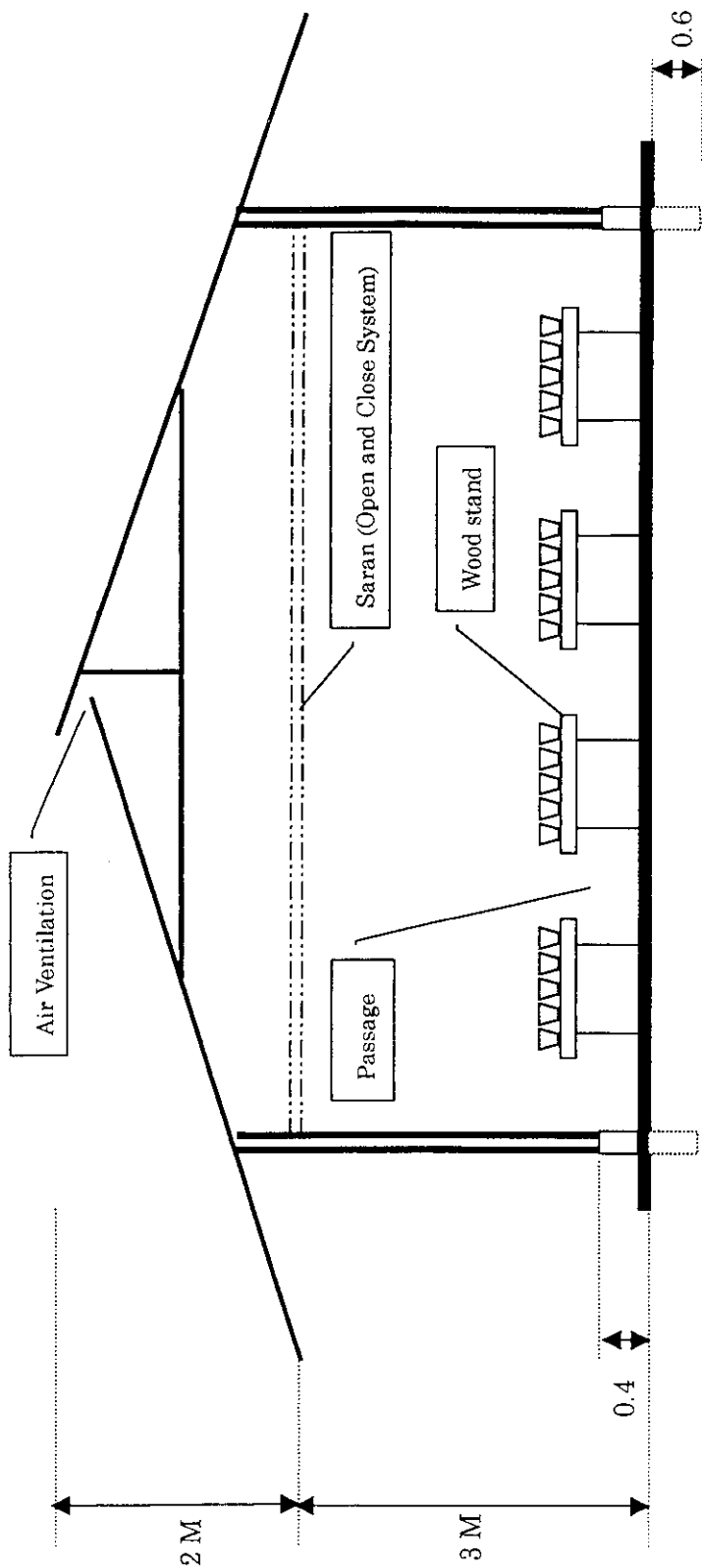

THE MASTER PLAN STUDY ON SUSTAINABLE RURAL  
DEVELOPMENT FOR THE REDUCTION OF POVERTY  
IN THE CENTRAL HIGHLAND REGION  
OF THE REPUBLIC OF GUATEMALA

Japan International Cooperation Agency (JICA)

**Figure 8.4.1(1)**  
**Conceptual Arrangement of Vinyl House**

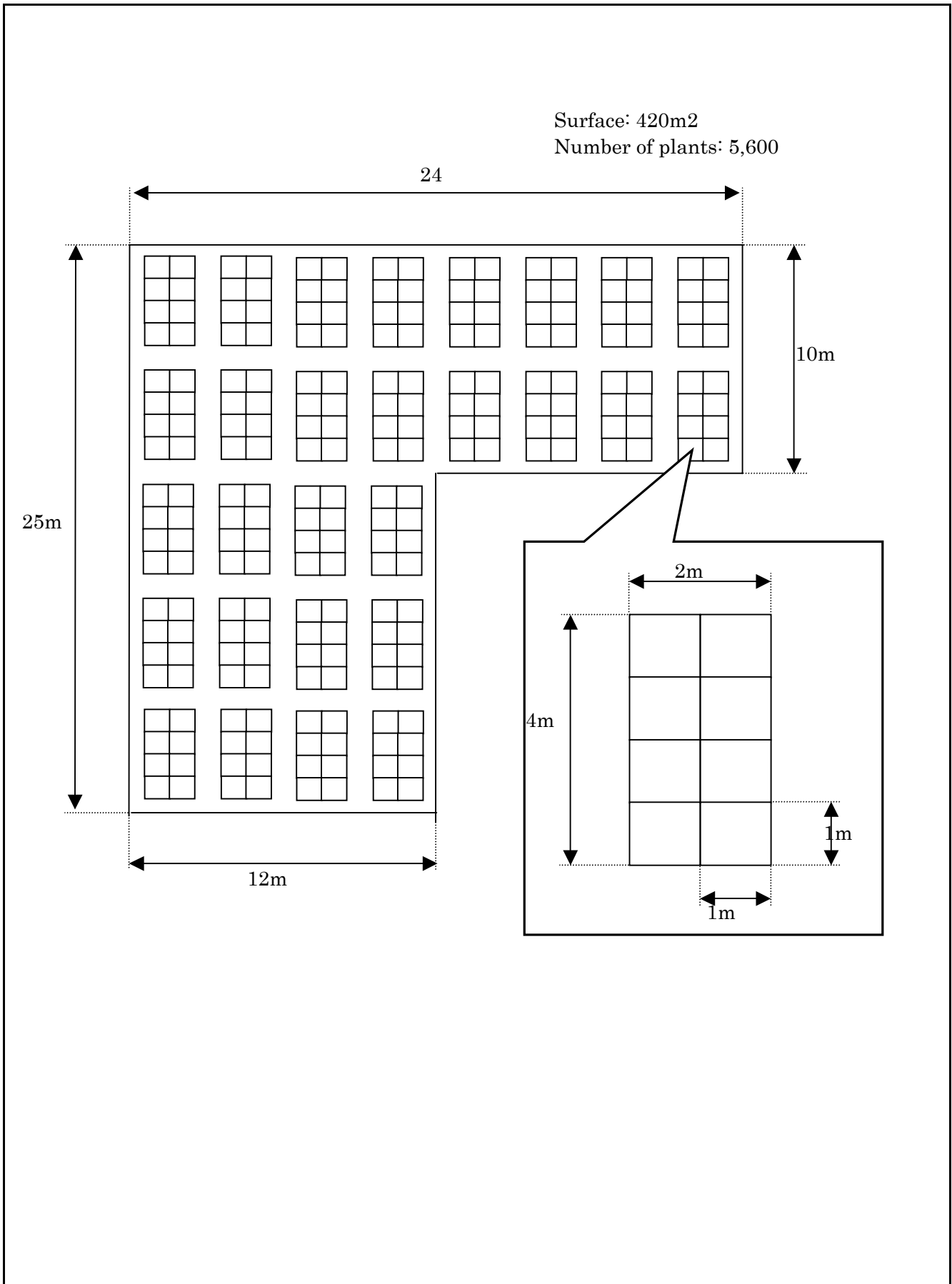

THE MASTER PLAN STUDY ON SUSTAINABLE RURAL  
 DEVELOPMENT FOR THE REDUCTION OF POVERTY  
 IN THE CENTRAL HIGHLAND REGION  
 OF THE REPUBLIC OF GUATEMALA

Japan International Cooperation Agency (JICA)

**Figure 8.4.1(2)**  
**Nursery Arrangement of Vinylhouse A**

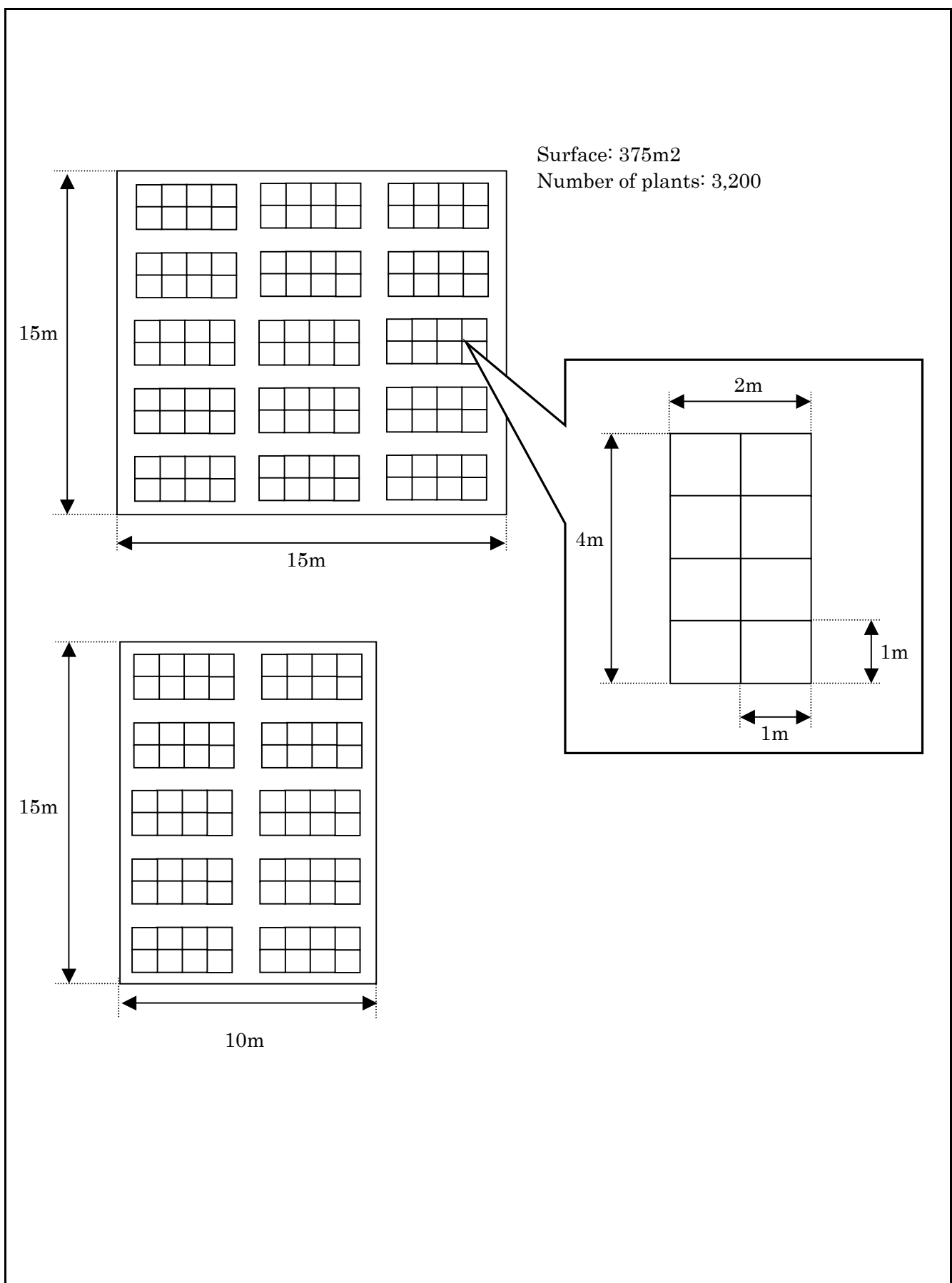

THE MASTER PLAN STUDY ON SUSTAINABLE RURAL  
DEVELOPMENT FOR THE REDUCTION OF POVERTY  
IN THE CENTRAL HIGHLAND REGION  
OF THE REPUBLIC OF GUATEMALA

Japan International Cooperation Agency (JICA)

**Figure 8.4.1(3)**  
**Nursery Arrangement of Vinyl House B**

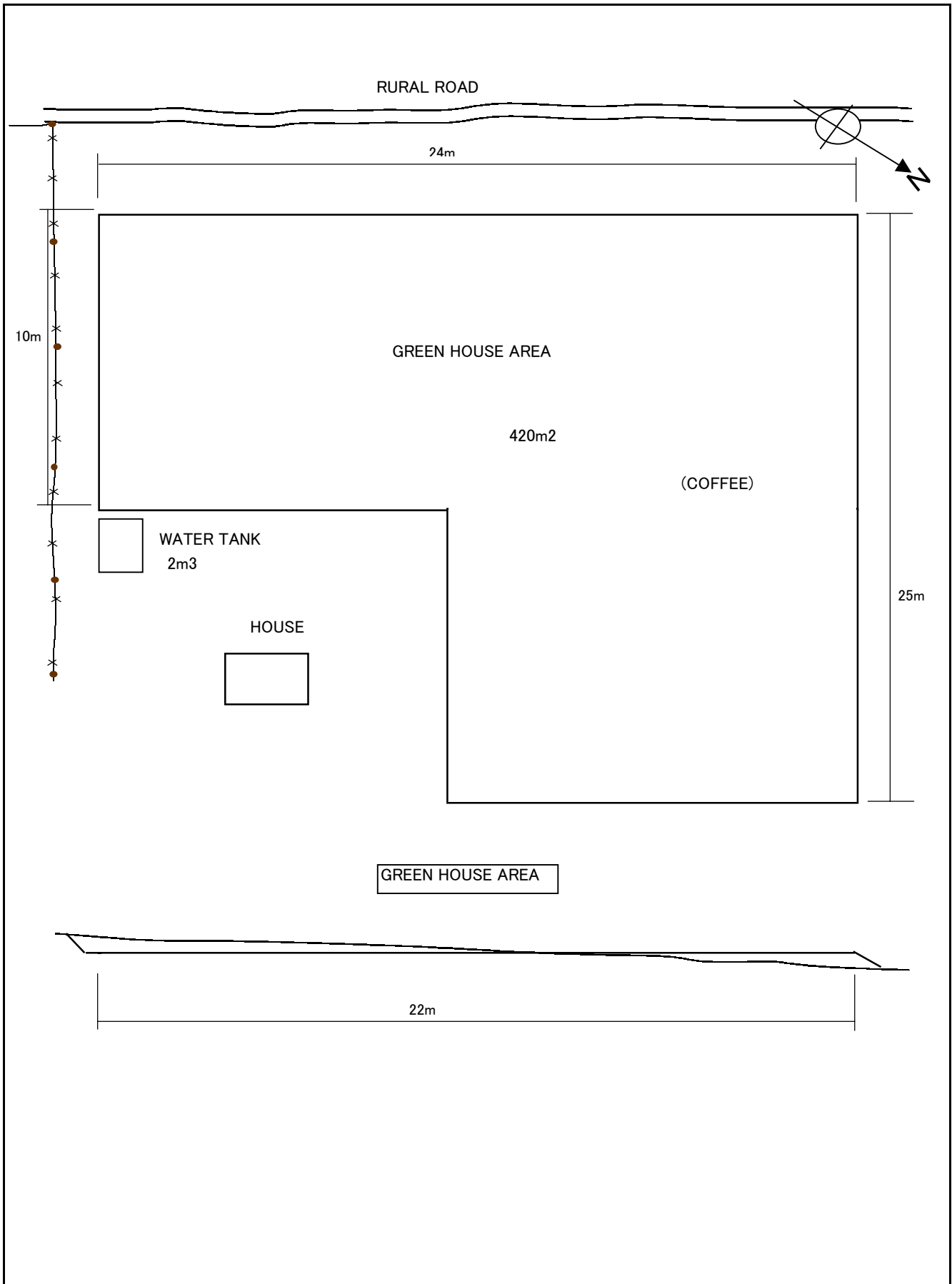

THE MASTER PLAN STUDY ON SUSTAINABLE RURAL  
DEVELOPMENT FOR THE REDUCTION OF POVERTY  
IN THE CENTRAL HIGHLAND REGION  
OF THE REPUBLIC OF GUATEMALA

Japan International Cooperation Agency (JICA)

**Figure 8.4.1(4)**  
**Proposed Land for Vinylhouse A**

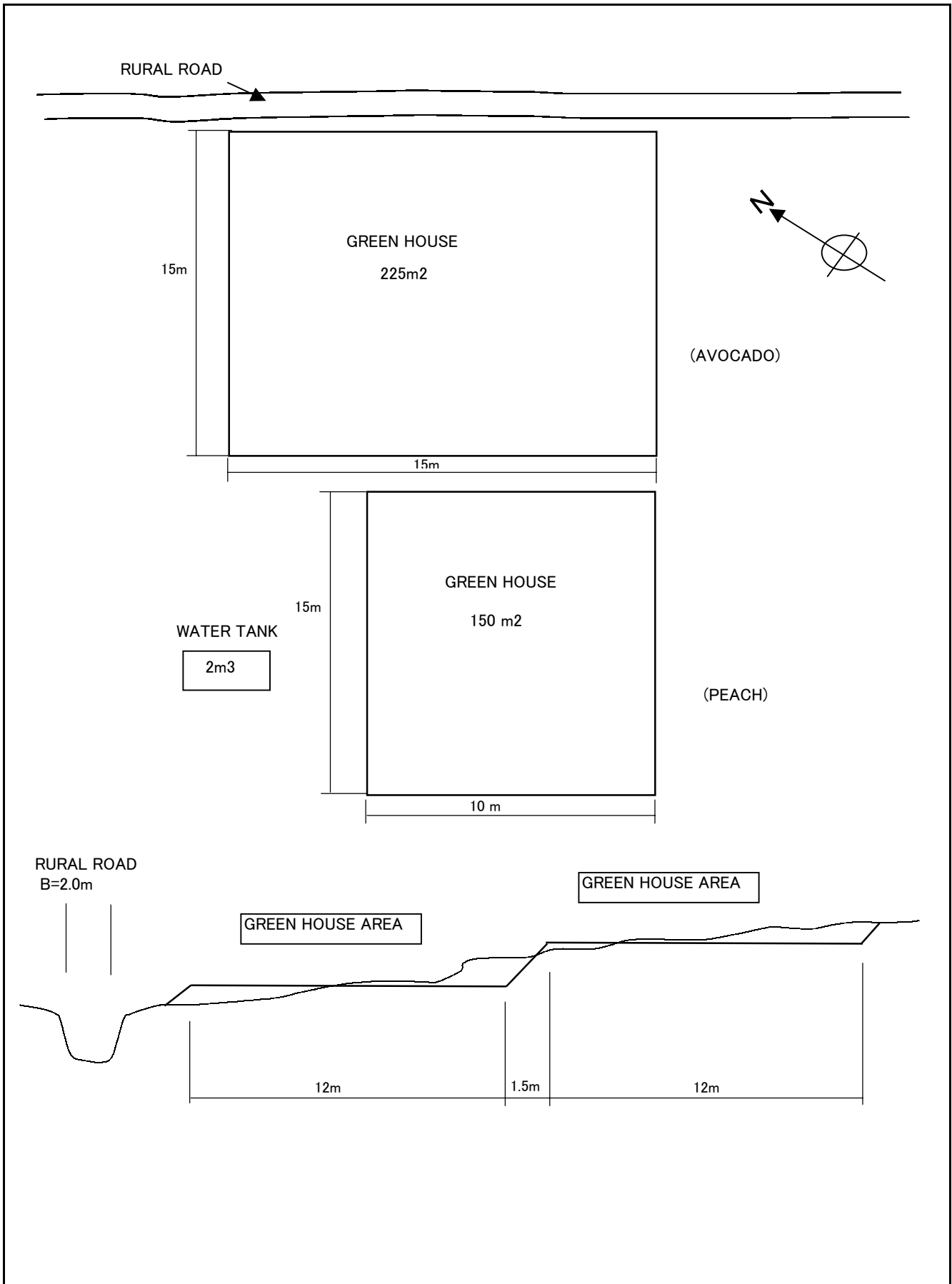

THE MASTER PLAN STUDY ON SUSTAINABLE RURAL  
DEVELOPMENT FOR THE REDUCTION OF POVERTY  
IN THE CENTRAL HIGHLAND REGION  
OF THE REPUBLIC OF GUATEMALA

Japan International Cooperation Agency (JICA)

**Figure 8.4.1(5)**  
**Proposed Land for Vinylhouse B**

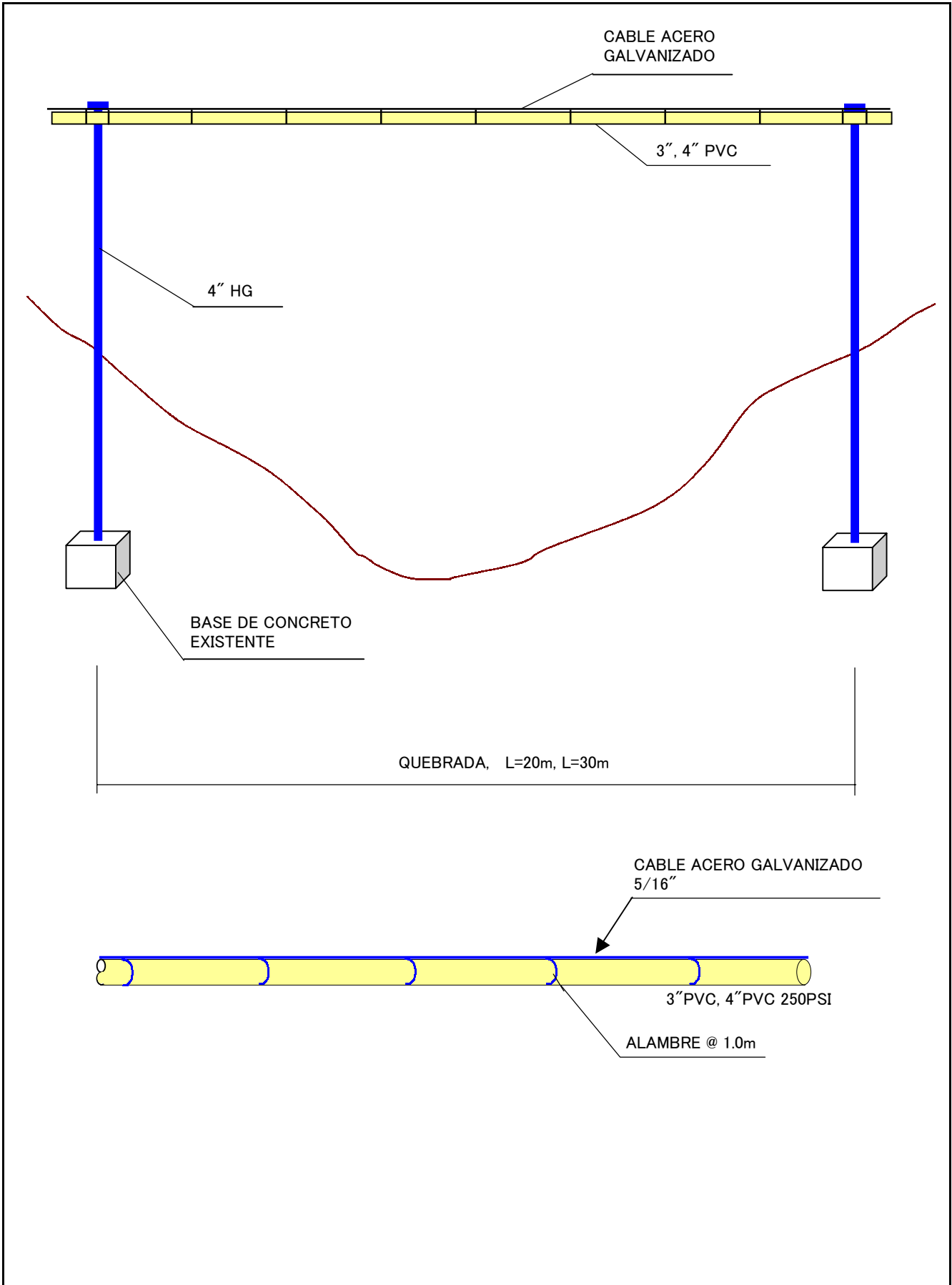

THE MASTER PLAN STUDY ON SUSTAINABLE RURAL DEVELOPMENT FOR THE REDUCTION OF POVERTY IN THE CENTRAL HIGHLAND REGION OF THE REPUBLIC OF GUATEMALA

Japan International Cooperation Agency (JICA)

**Figure 8.4.2(1)**  
**Drinking Water System Improvement**  
**River crossing work**  
**Panyebar, Solola**

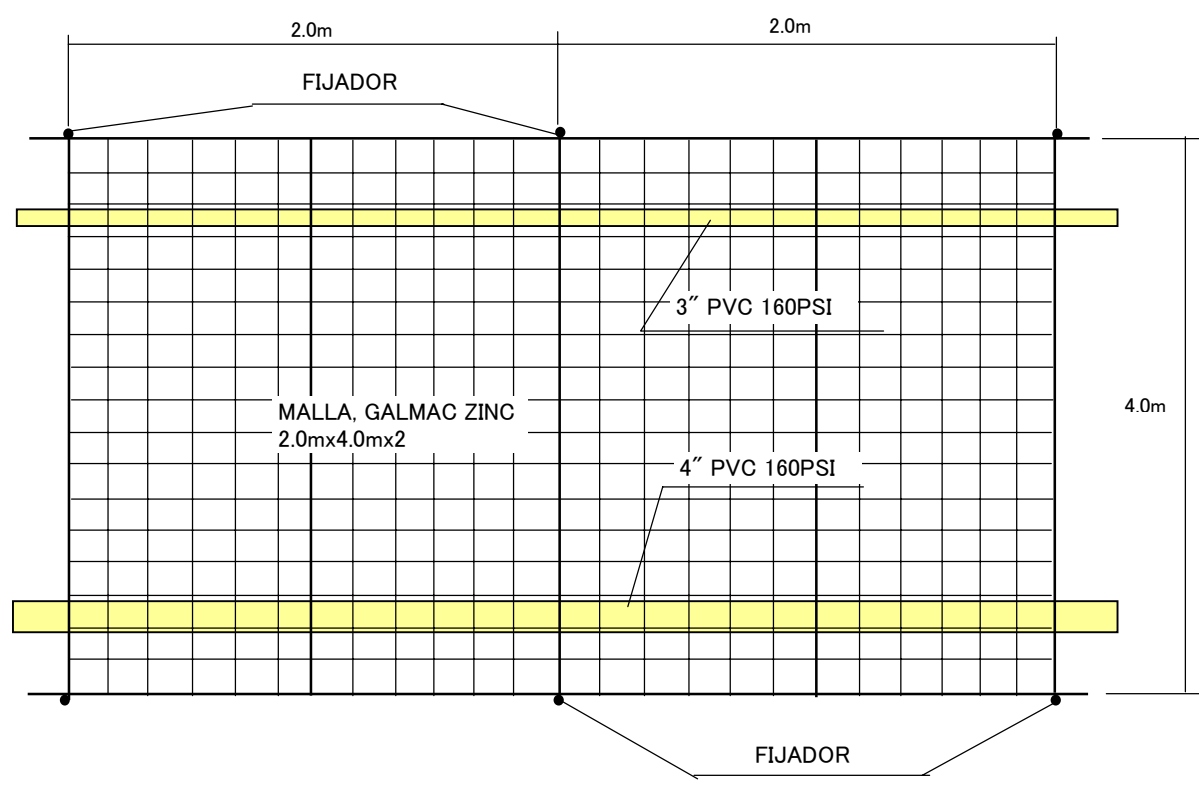
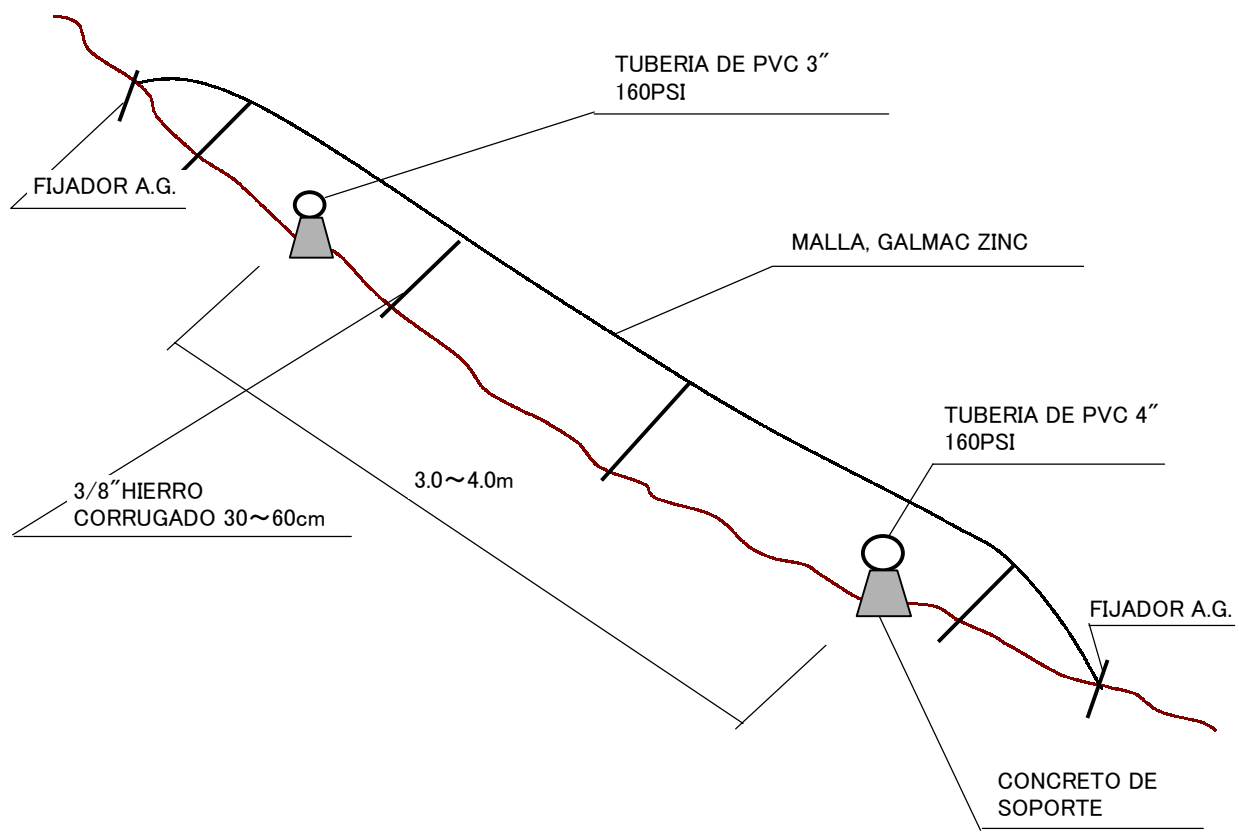

THE MASTER PLAN STUDY ON SUSTAINABLE RURAL DEVELOPMENT FOR THE REDUCTION OF POVERTY IN THE CENTRAL HIGHLAND REGION OF THE REPUBLIC OF GUATEMALA

Japan International Cooperation Agency (JICA)

**Figure 8.4.2(2)**  
**Drinking Water System Improvement**  
**Pipe protection work**  
**Panyebar, Solola**

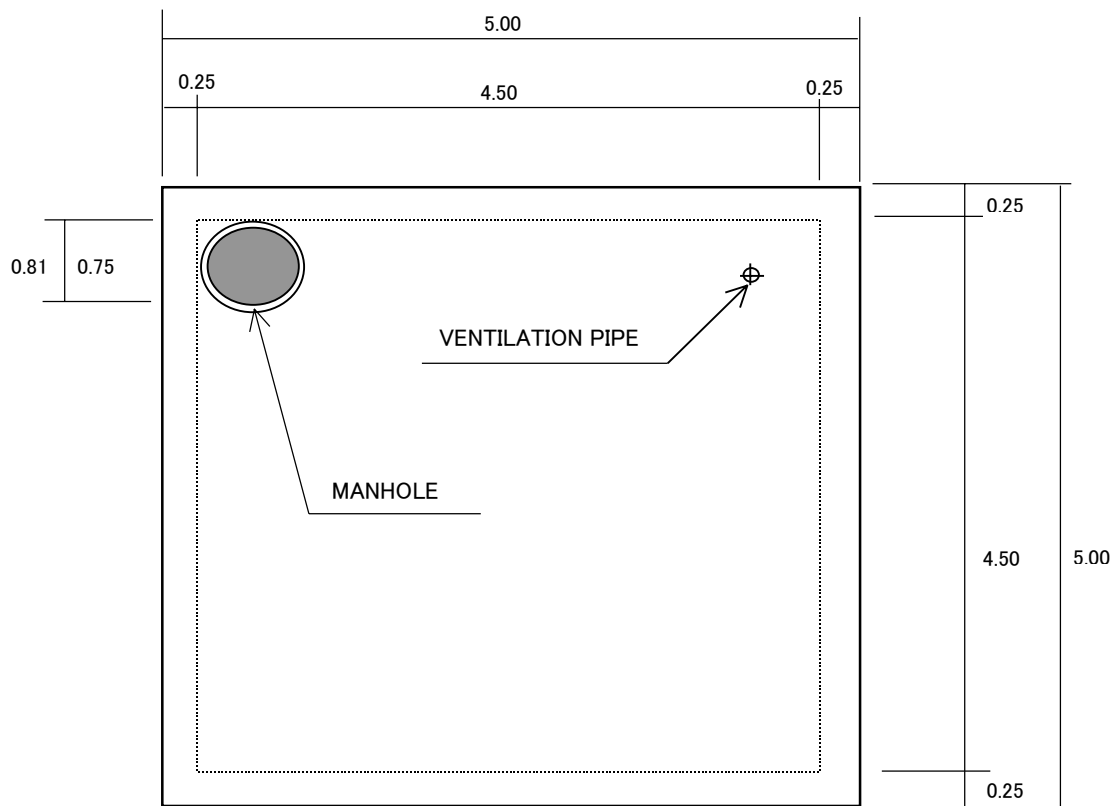

THE MASTER PLAN STUDY ON SUSTAINABLE RURAL  
DEVELOPMENT FOR THE REDUCTION OF POVERTY  
IN THE CENTRAL HIGHLAND REGION  
OF THE REPUBLIC OF GUATEMALA

Japan International Cooperation Agency (JICA)

Figure 8.4.2(3)

Drinking Water System Improvement  
Distribution Tank (1)

Plan Top Level, Panyebar, Solola



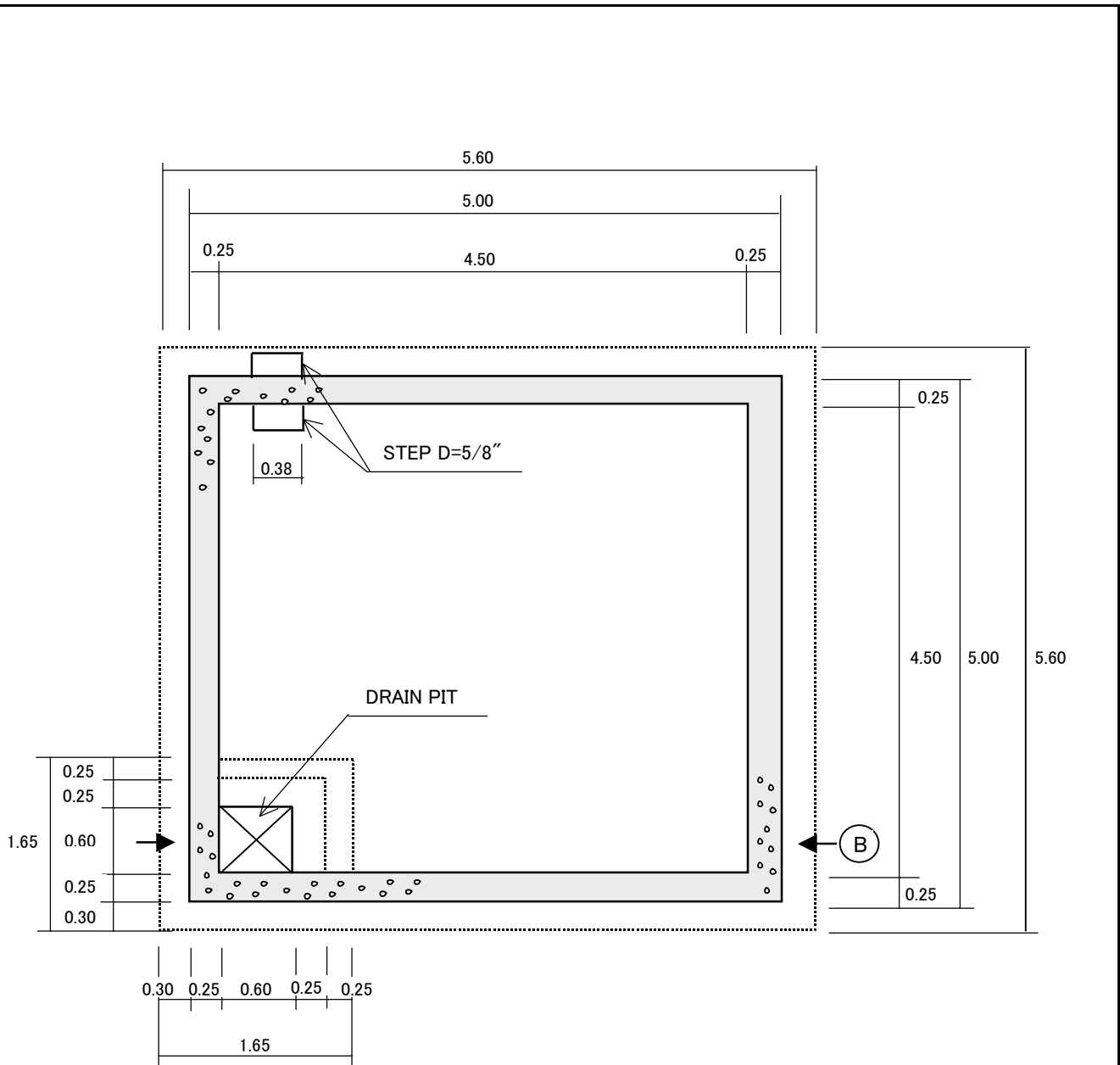

THE MASTER PLAN STUDY ON SUSTAINABLE RURAL  
DEVELOPMENT FOR THE REDUCTION OF POVERTY  
IN THE CENTRAL HIGHLAND REGION  
OF THE REPUBLIC OF GUATEMALA

Japan International Cooperation Agency (JICA)

**Figure 8.4.2 (4)**  
**Drinking Water System Improvement**  
**Distribution Tank (2) Plan Bottom Level**  
**Panyebar, Solola**

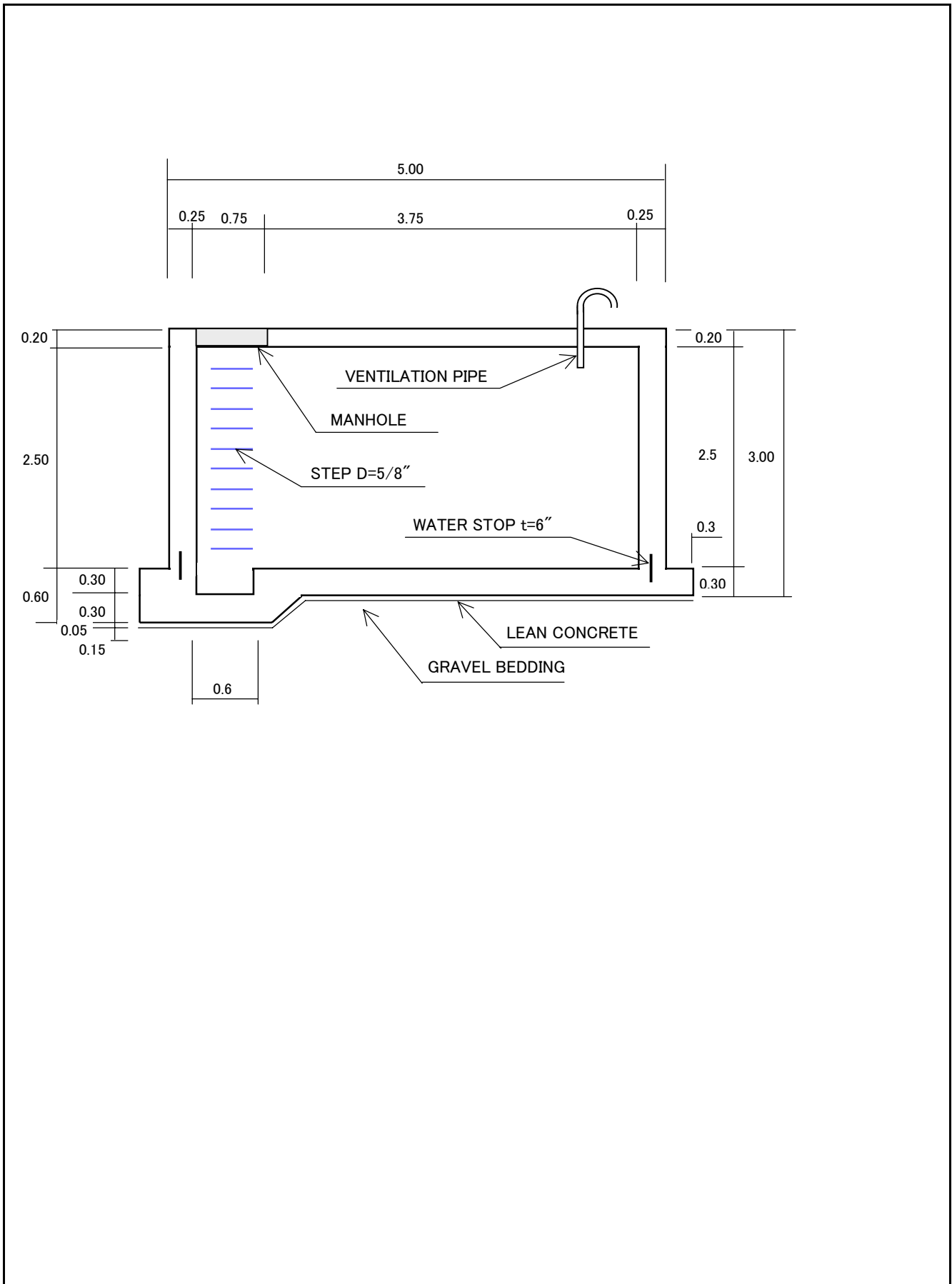

THE MASTER PLAN STUDY ON SUSTAINABLE RURAL DEVELOPMENT FOR THE REDUCTION OF POVERTY IN THE CENTRAL HIGHLAND REGION OF THE REPUBLIC OF GUATEMALA

Japan International Cooperation Agency (JICA)

Figure 8.4.2 (5)

Drinking Water System Improvement Distribution Tank (3),

Longitudinal Section "B", Panyebar, Solola

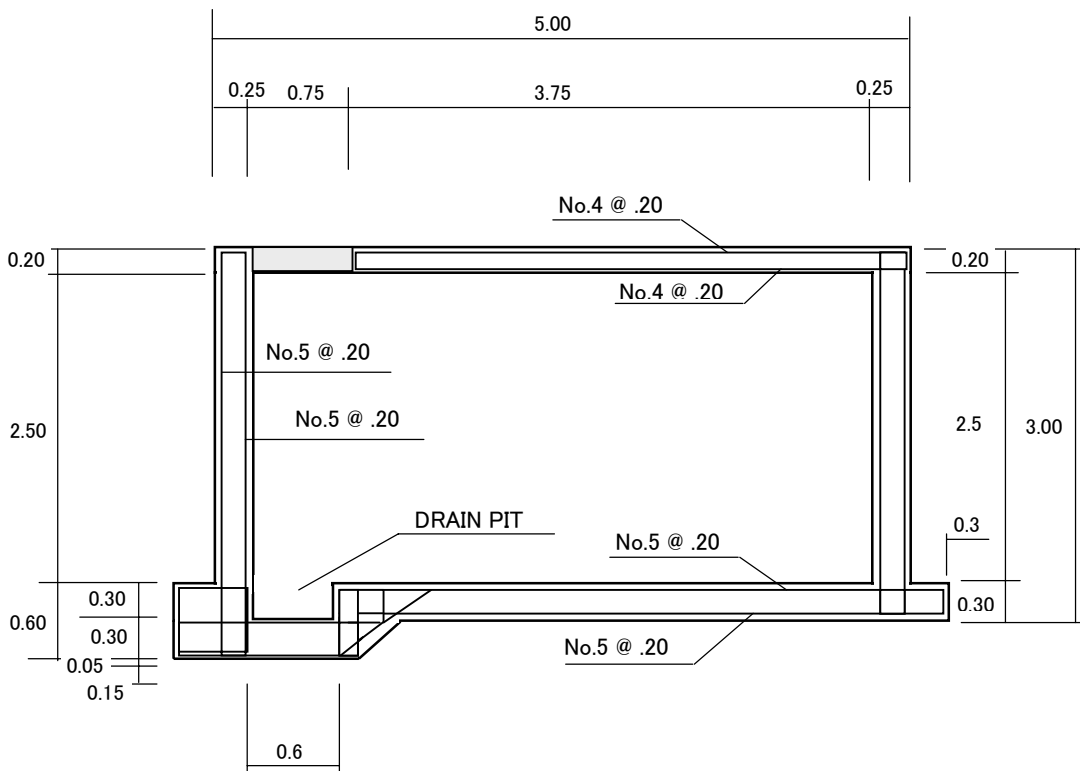

THE MASTER PLAN STUDY ON SUSTAINABLE RURAL  
DEVELOPMENT FOR THE REDUCTION OF POVERTY  
IN THE CENTRAL HIGHLAND REGION  
OF THE REPUBLIC OF GUATEMALA

Japan International Cooperation Agency (JICA)

**Figure 8.4.2 (6)**  
**Drinking Water System Improvement**  
**Distribution Tank (4), Longitudinal Section "B",**  
**Reinforced Steel Bars**  
**Panychar, Solola**

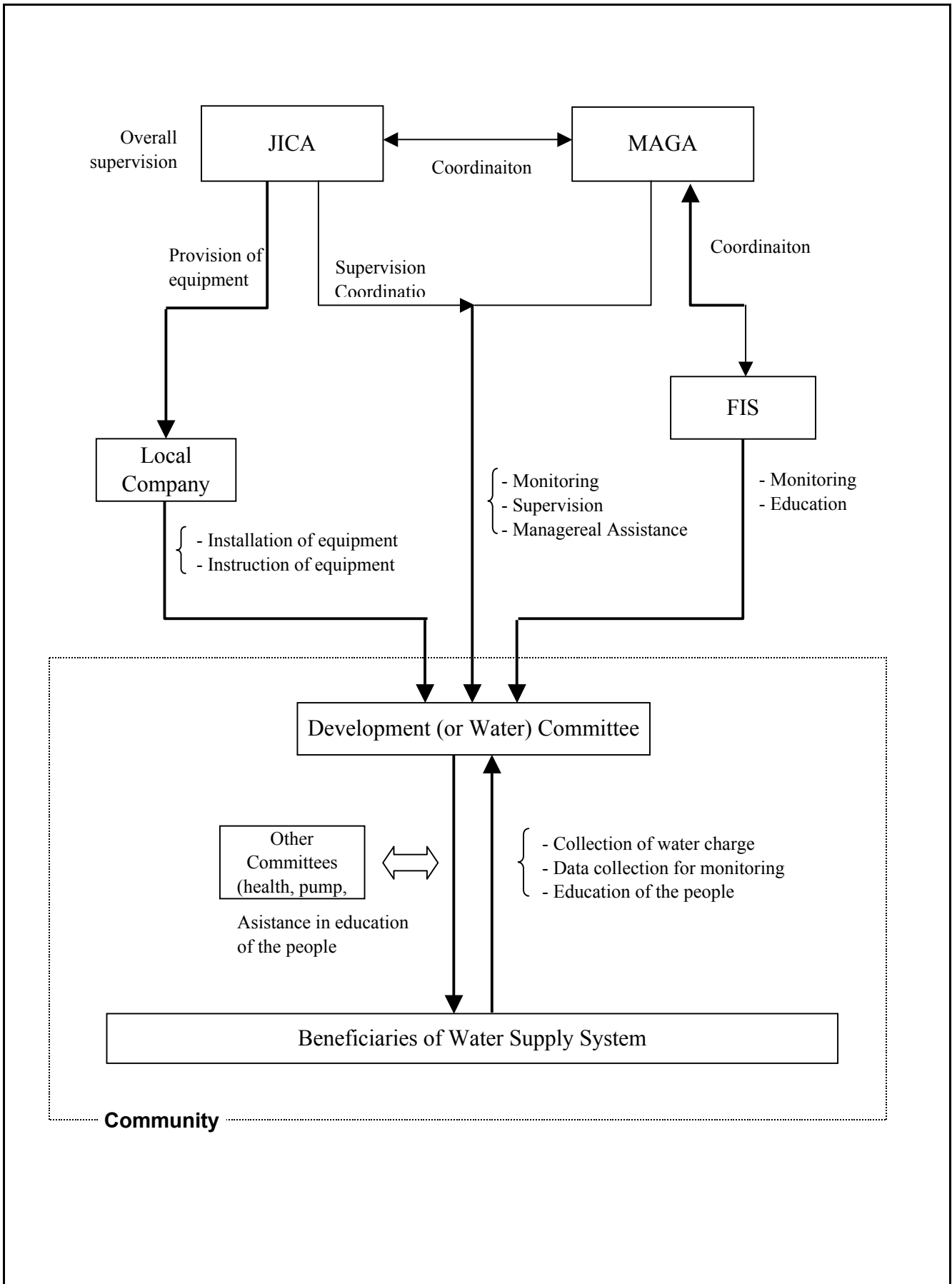

THE MASTER PLAN STUDY ON SUSTAINABLE RURAL DEVELOPMENT FOR THE REDUCTION OF POVERTY IN THE CENTRAL HIGHLAND REGION OF THE REPUBLIC OF GUATEMALA

Japan International Cooperation Agency (JICA)

**Figure 8.4.3 (1)**  
**Organization and Supporting Structure for Water Quality**

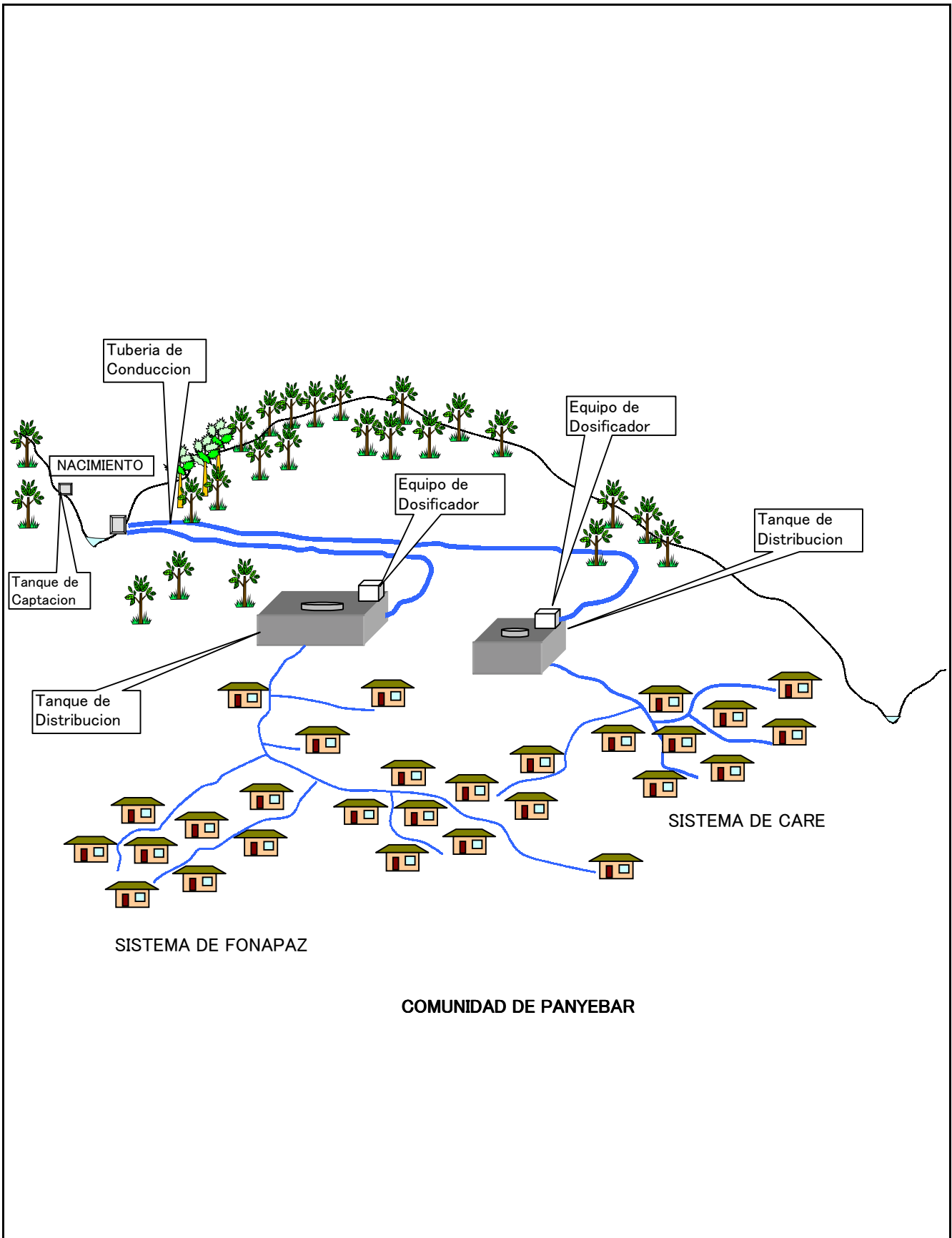

THE MASTER PLAN STUDY ON SUSTAINABLE RURAL DEVELOPMENT FOR THE REDUCTION OF POVERTY IN THE CENTRAL HIGHLAND REGION OF THE REPUBLIC OF GUATEMALA

Japan International Cooperation Agency (JICA)

Figure 8.4.3(2)

Drinking Water Quality Improvement Plan  
Outline of Drinking Water Supply System  
Panyebar, San Juan La Laguna, Solola