

9128000

9127000

9126000

9125000

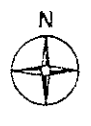

TIMBO RIVER

SEWAGE DISCHARGE PIPES

UE-04

C-4/04

C-1/04

EE-1/04

UE-06

EEJ-11

EEJ-10

EE-4/05

UE-05

EEJ-18

EE-1/05

EE-3/05

EE-2/05

EEJ-05

EEJ-06

EEJ-13

EEJ-12

AE 3

UE-

A-3/22

A-1/22

A-2/22

UE-22

9119000

9118000

9120000

9121000

9122000

9123000

9124000

9125000

9126000

9127000

9128000

300000

299000

9124000

9123000

9122000

9121000

9120000

9119000

9118000

9117000



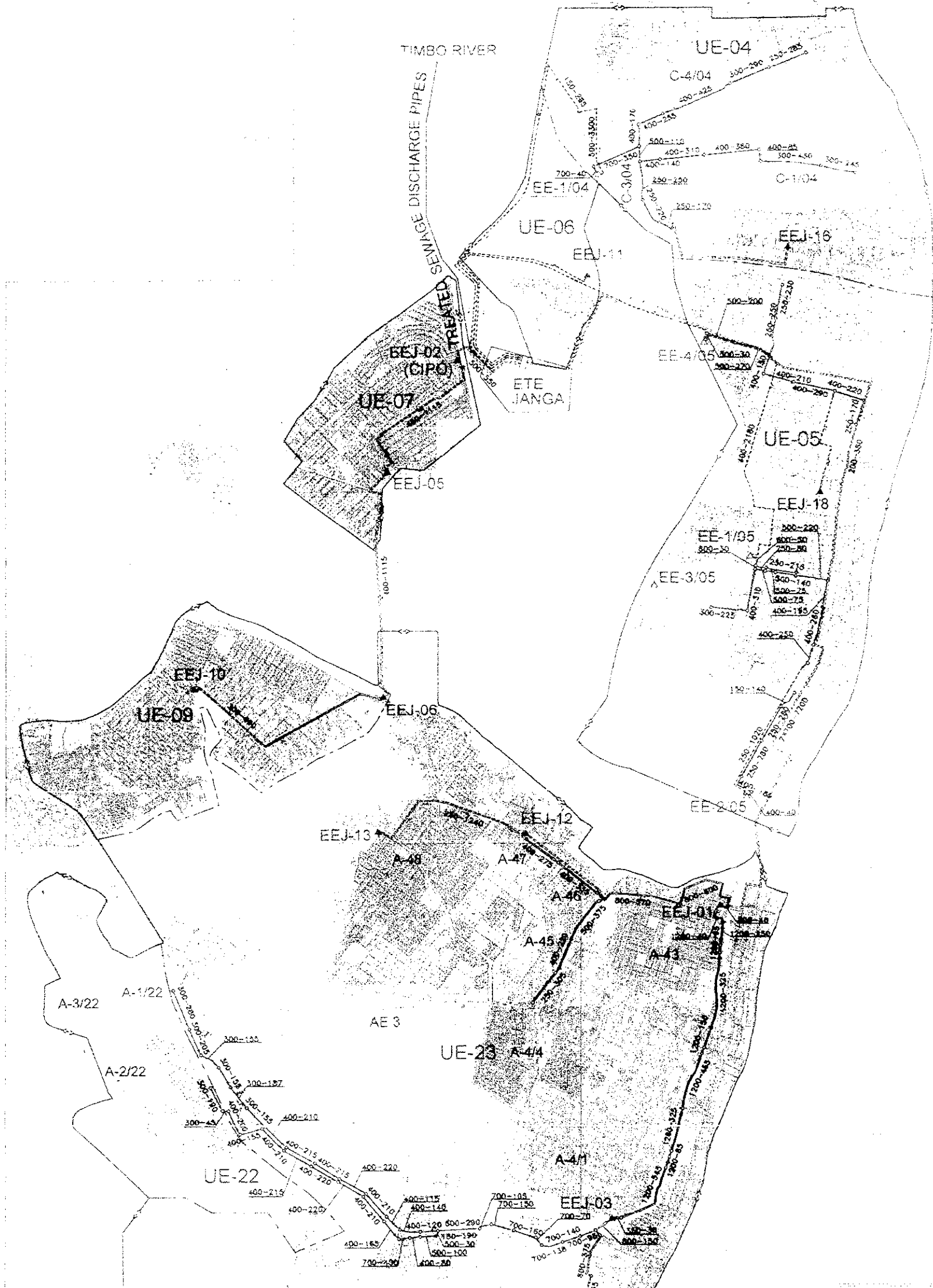

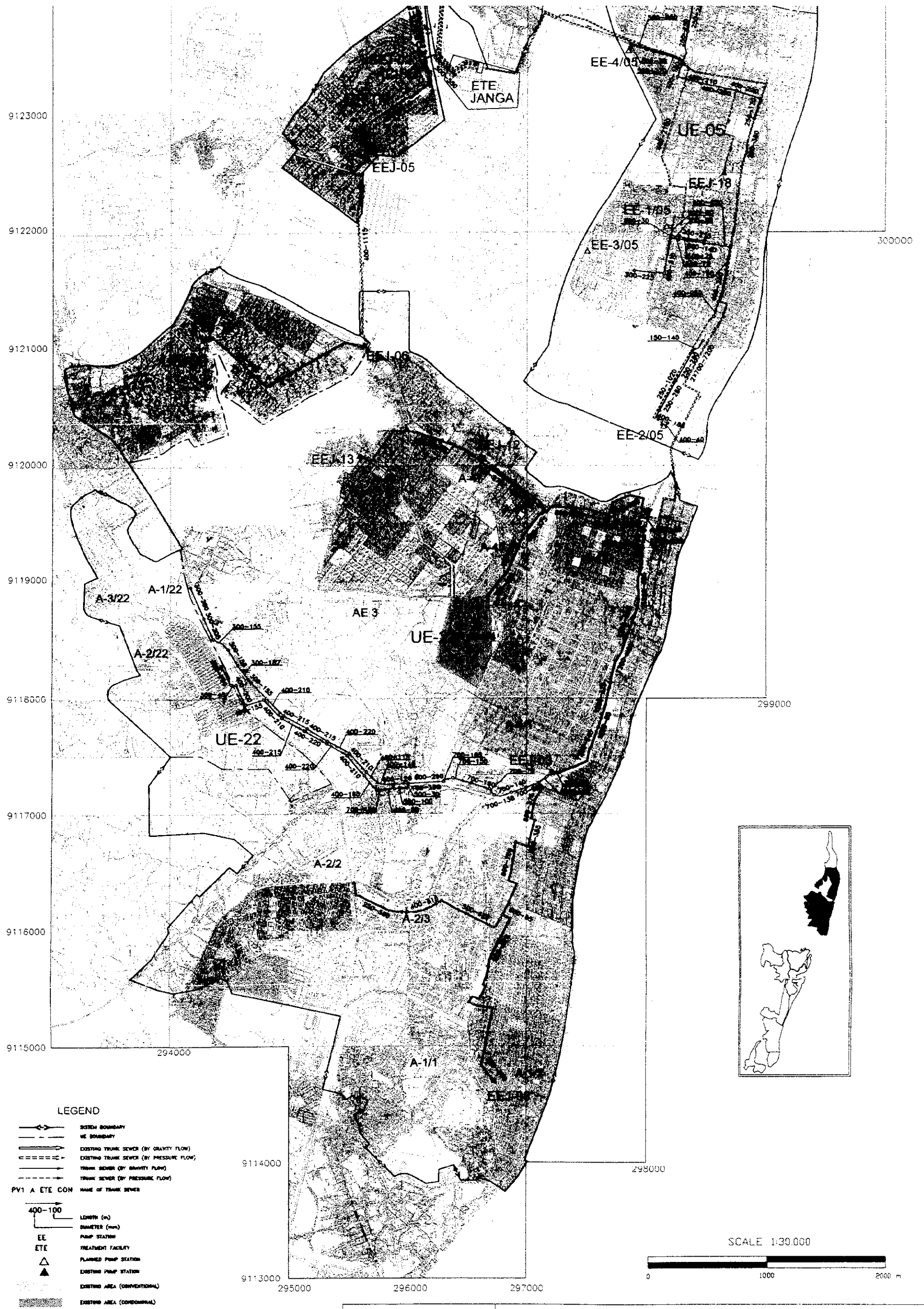

Fig. A.4-3 Layout Plan of Janga System
 THE STUDY ON STORMWATER DRAINAGE AND SEWERAGE MANAGEMENT PLAN FOR RMR

9112000

9110000

9109000

9105000

9104000

9103000

9102000

9101000

EEC-47

FRONTE
MADURO

D-6

D-9
EEEX-08

BEX-04

D-3

EEG-1145

UE-44

EE-1144

A-2145

D-6A

UE-45

UE-95 (EE-4795)

EE-1795

C-2195

SEC-1

TREATED SEWAGE
DISCHARGE PIPE

D-2A

UE-89

EEC (PINA)

LA
MOSA

UE-88

EEC-03

UE-87

D-15

C-11015



294000

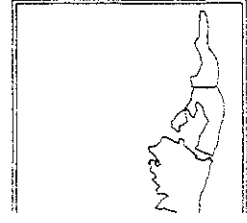

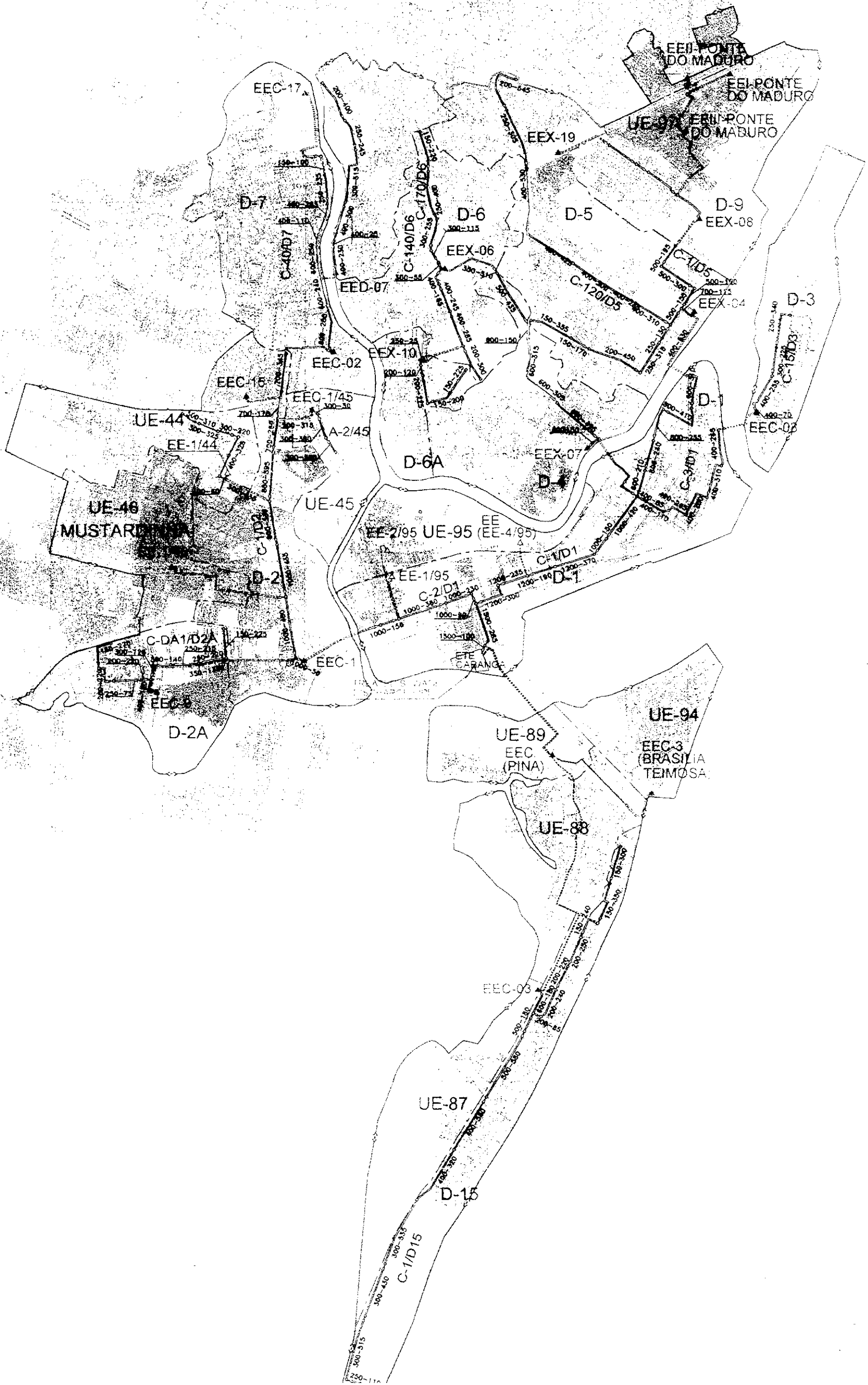

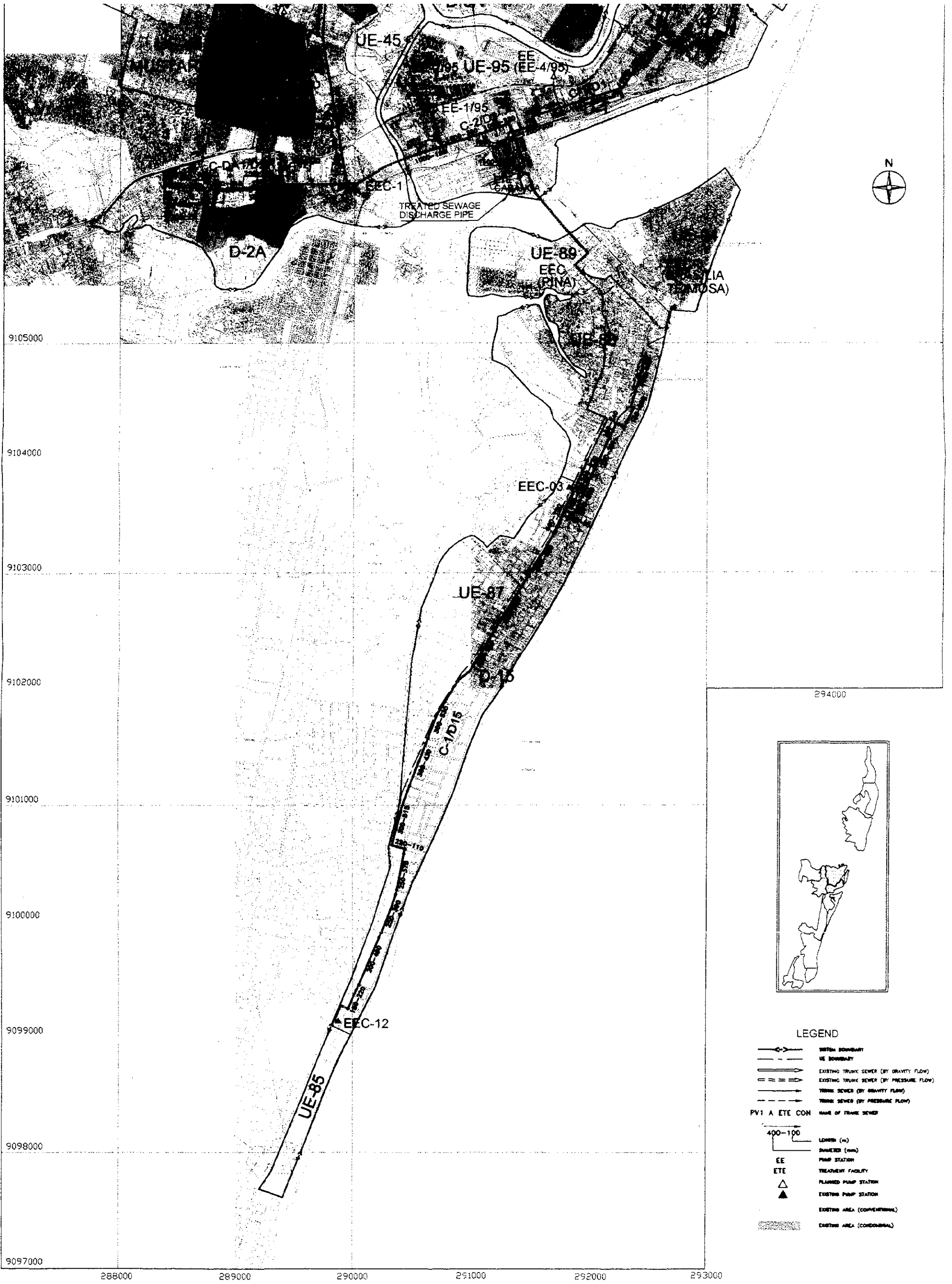

A - 130

Fig. A.4-4

Layout Plan of Cabanga System

THE STUDY ON STORMWATER DRAINAGE AND SEWERAGE MANAGEMENT PLAN FOR RMR

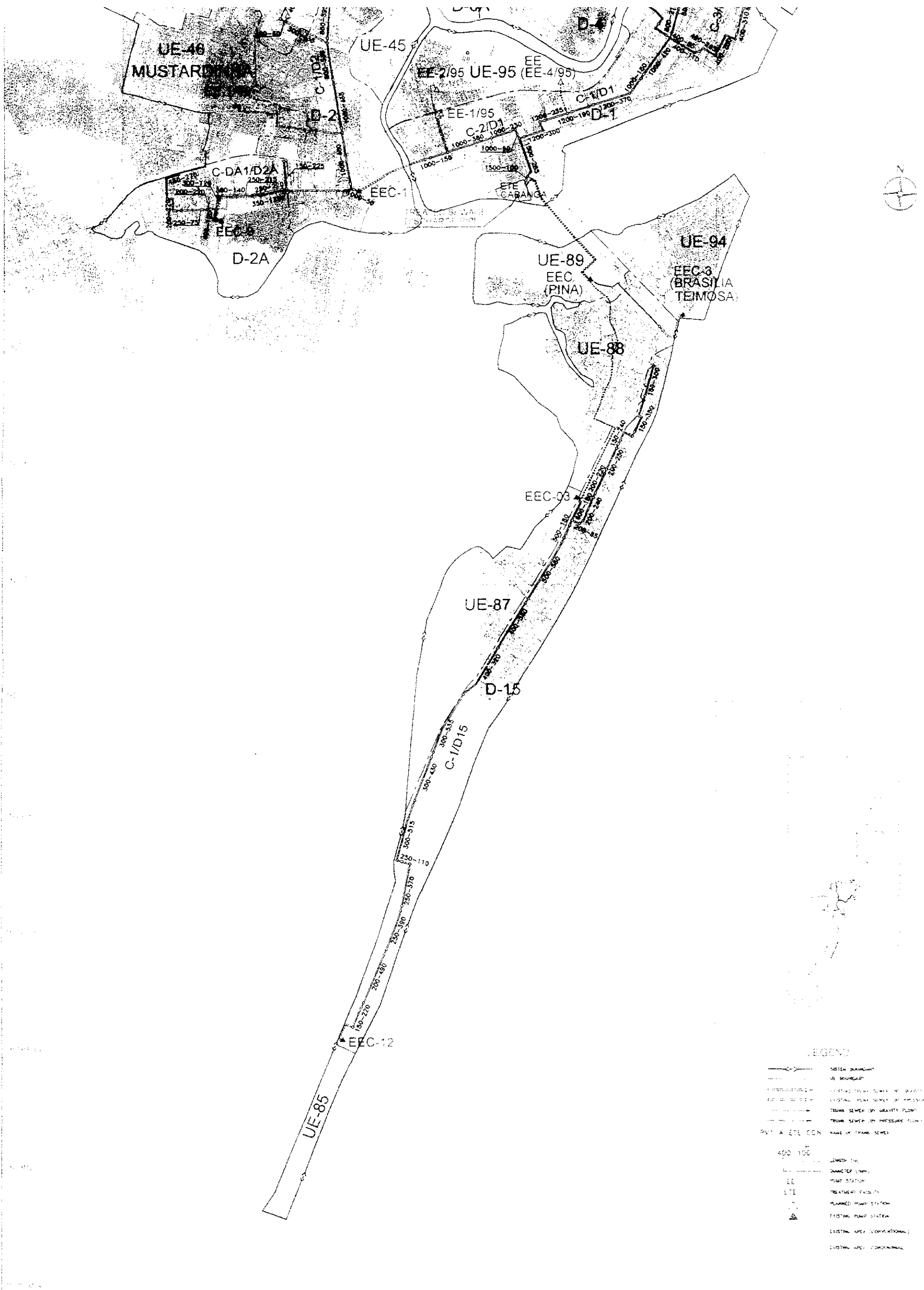

A-130

Fig. A.4-4

Layout Plan of Cabanga System

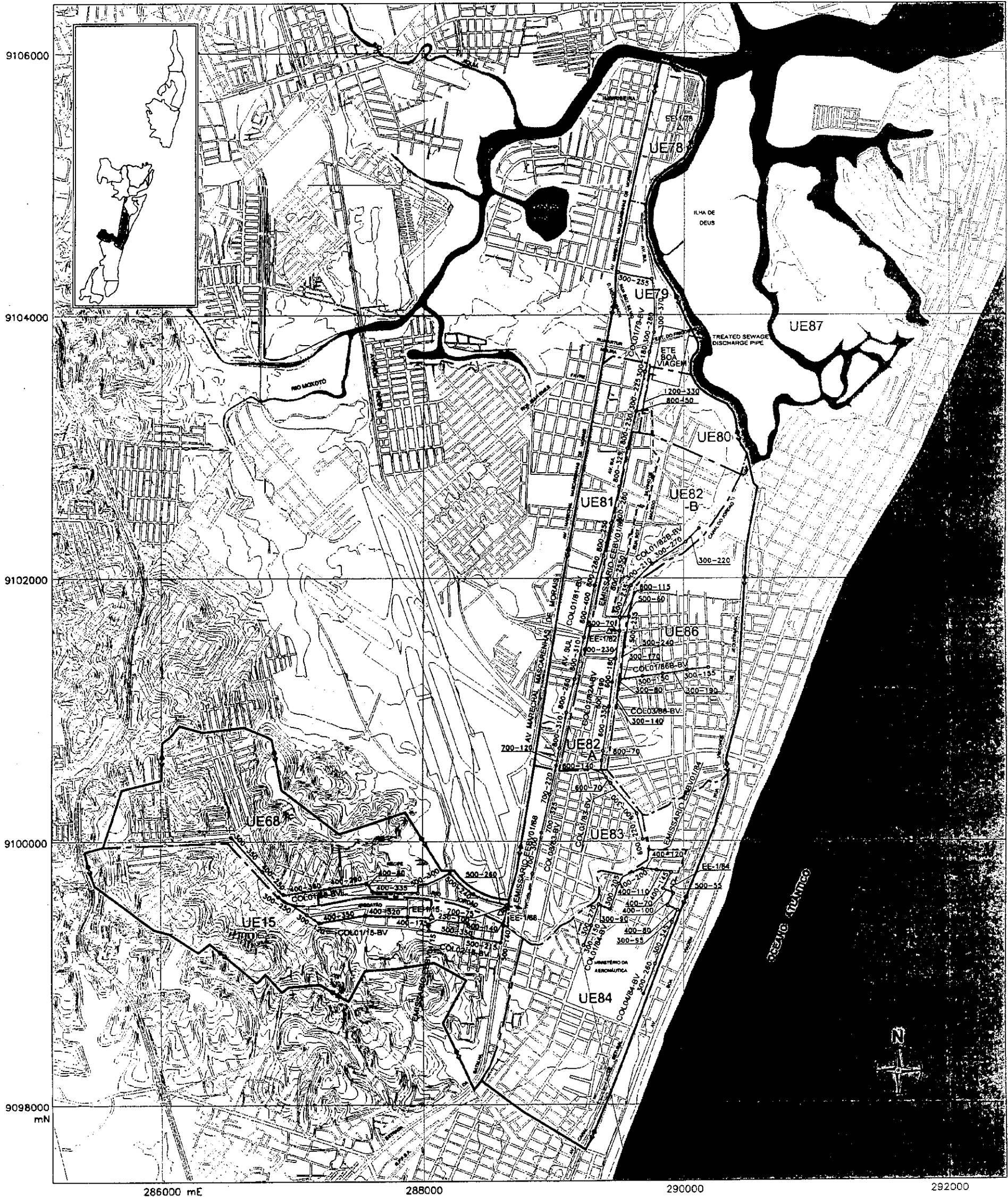

- LEGEND**
- SYSTEM BOUNDARY
 - UE BOUNDARY
 - TRUNK SEWER (BY GRAVITY FLOW)
 - TRUNK SEWER (BY PRESSURE FLOW)
 - COL01/81-BV NAME OF TRUNK SEWER
 - LENGTH (m)
DIAMETER (mm)
 - EE PUMP STATION
 - ETE TREATMENT FACILITY
 - PLANNED PUMP STATION
 - EXISTING PUMP STATION

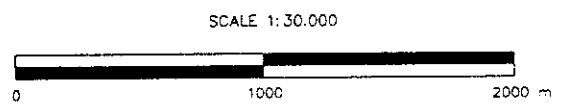

Fig. A.4-5

Layout Plan of Boa Viagem System

THE STUDY ON STORMWATER DRAINAGE AND SEWERAGE MANAGEMENT PLAN FOR RMR

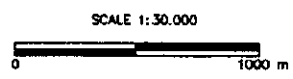
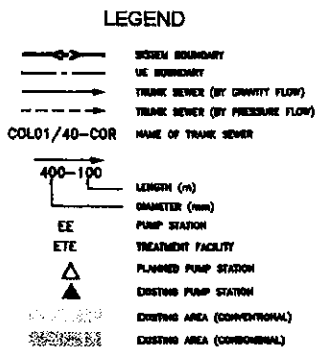
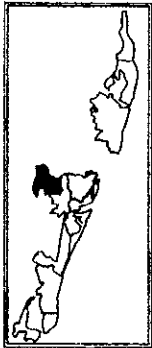
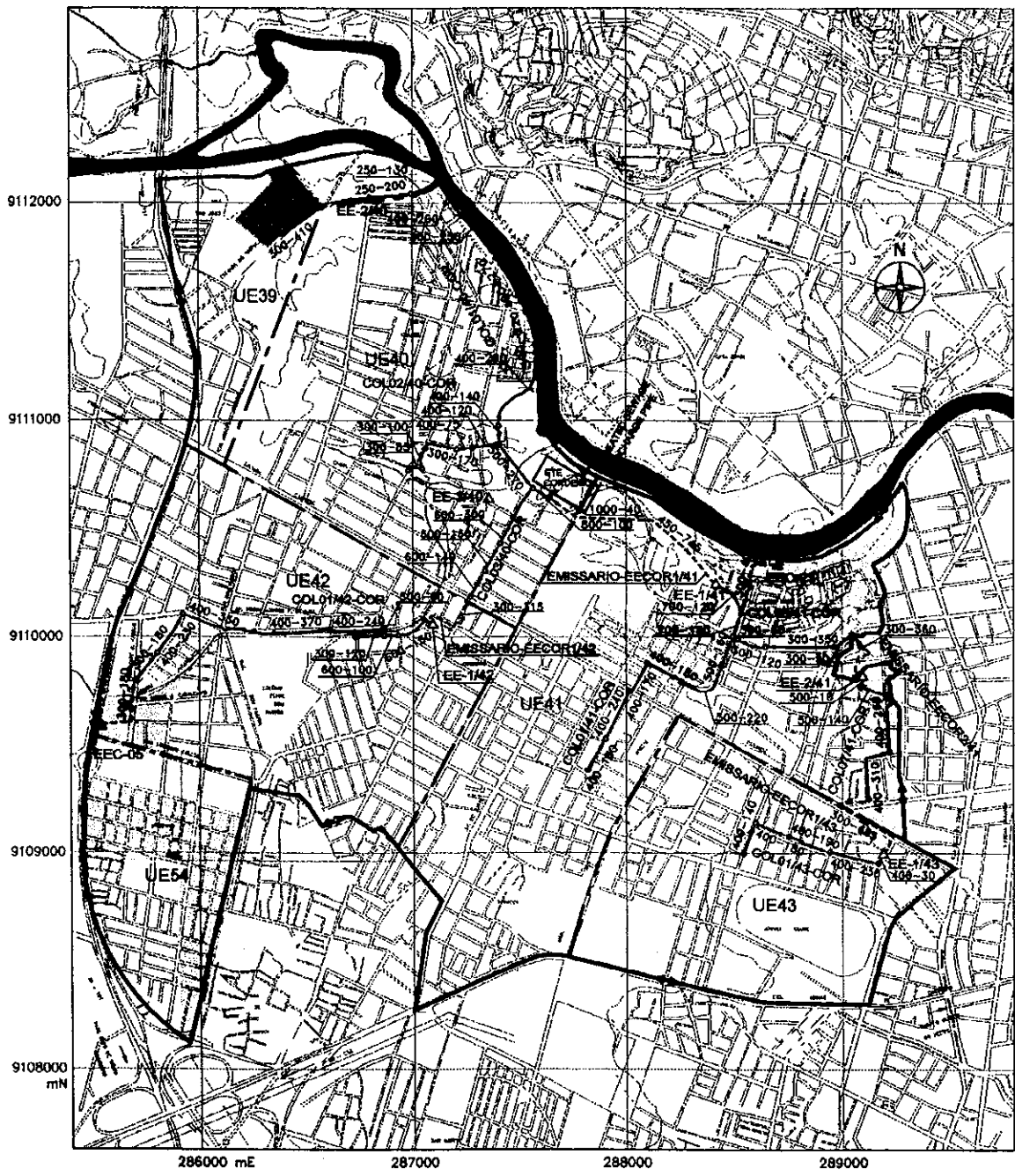

Fig. A.4-6 **Layout Plan of Cordeiro System**

THE STUDY ON STORMWATER DRAINAGE AND SEWERAGE MANAGEMENT PLAN FOR RMR



- LEGEND**
- SEWERAGE PIPE
 - UE BOUNDARY
 - TRUNK SEWER (BY GRAVITY FLOW)
 - TRUNK SEWER (BY PRESSURE FLOW)
 - COL01/18-PRZ
 - PIPE OF SEWER SEWER
 - LIBERTY (m)
 - DIAMETER (mm)
 - PUMP STATION
 - ETE
 - FLUSHED PUMP STATION
 - EXISTING PUMP STATION
 - EXISTING AREA (CONTAMINATED)
 - EXISTING AREA (NON-CONTAMINATED)

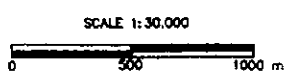
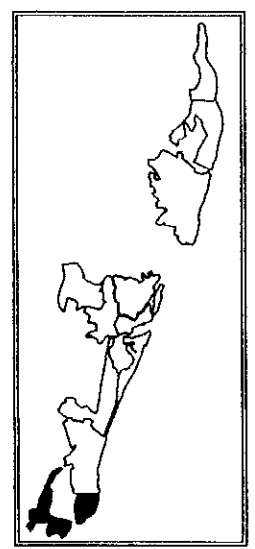
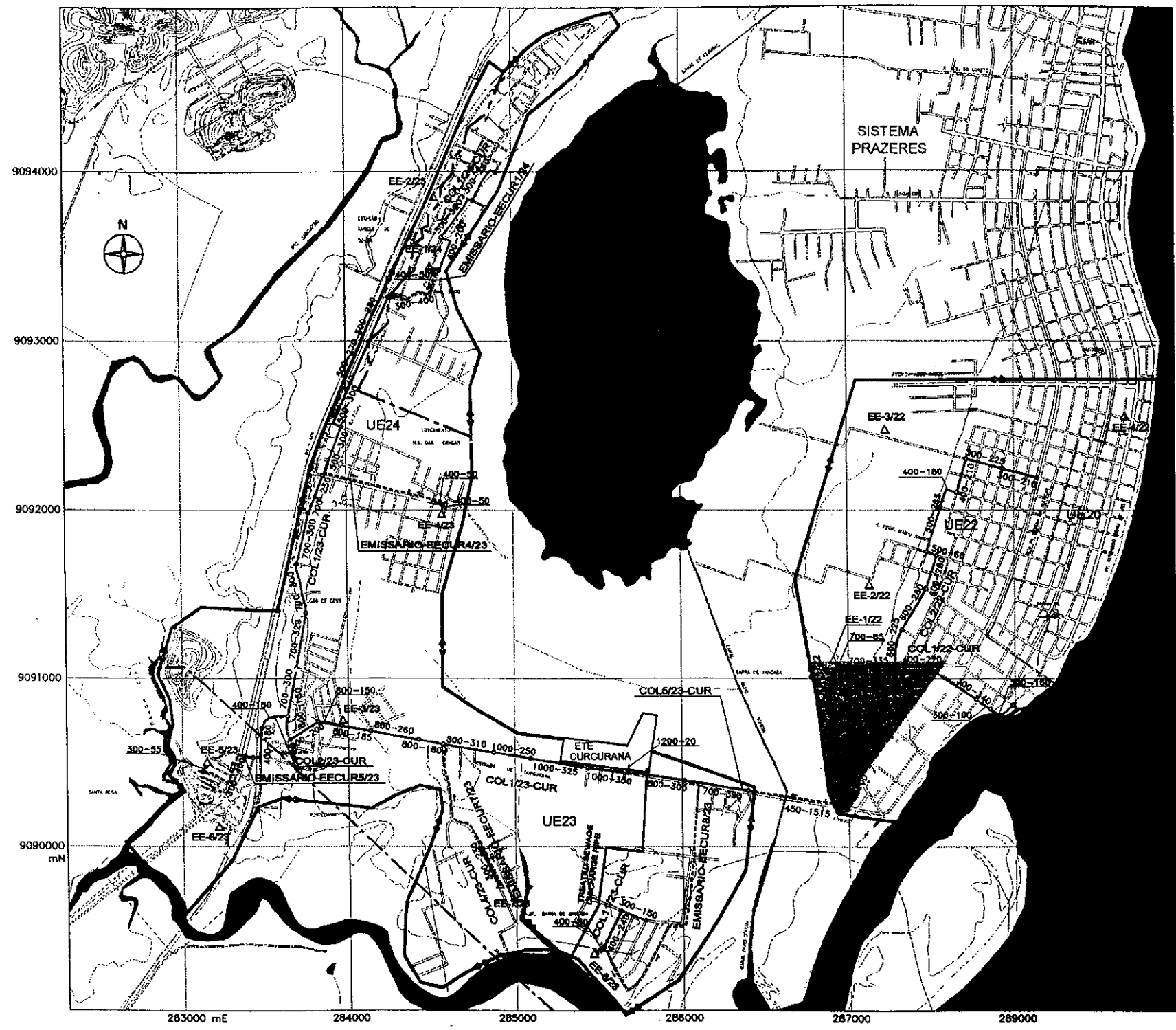

Fig. A.4-7 **Layout Plan of Prazeres System**

THE STUDY ON STORMWATER DRAINAGE AND SEWERAGE MANAGEMENT PLAN FOR RMR



LEGEND

- SISTEM BOUNDARY
- UE BOUNDARY
- TRUNK SEWER (BY GRAVITY FLOW)
- TRUNK SEWER (BY PRESSURE FLOW)
- NAME OF TRUNK SEWER
- LENGTH (m)
- DIAMETER (mm)
- PUMP STATION
- TREATMENT FACILITY
- PLANNED PUMP STATION
- EXISTING PUMP STATION
- EXISTING AREA (CONVENTIONAL)
- EXISTING AREA (CONDOMINIAL)

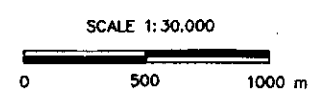
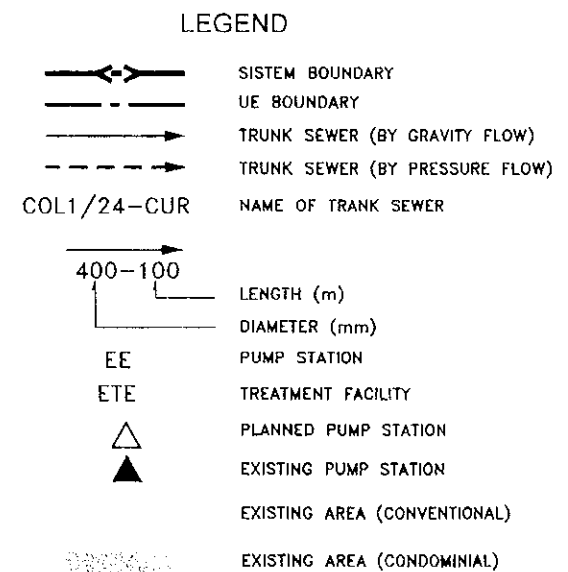
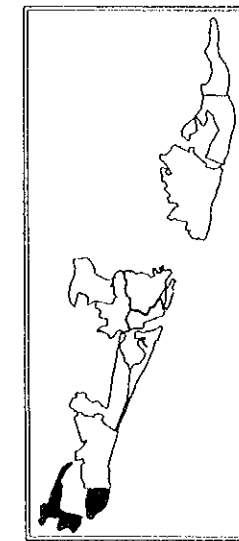
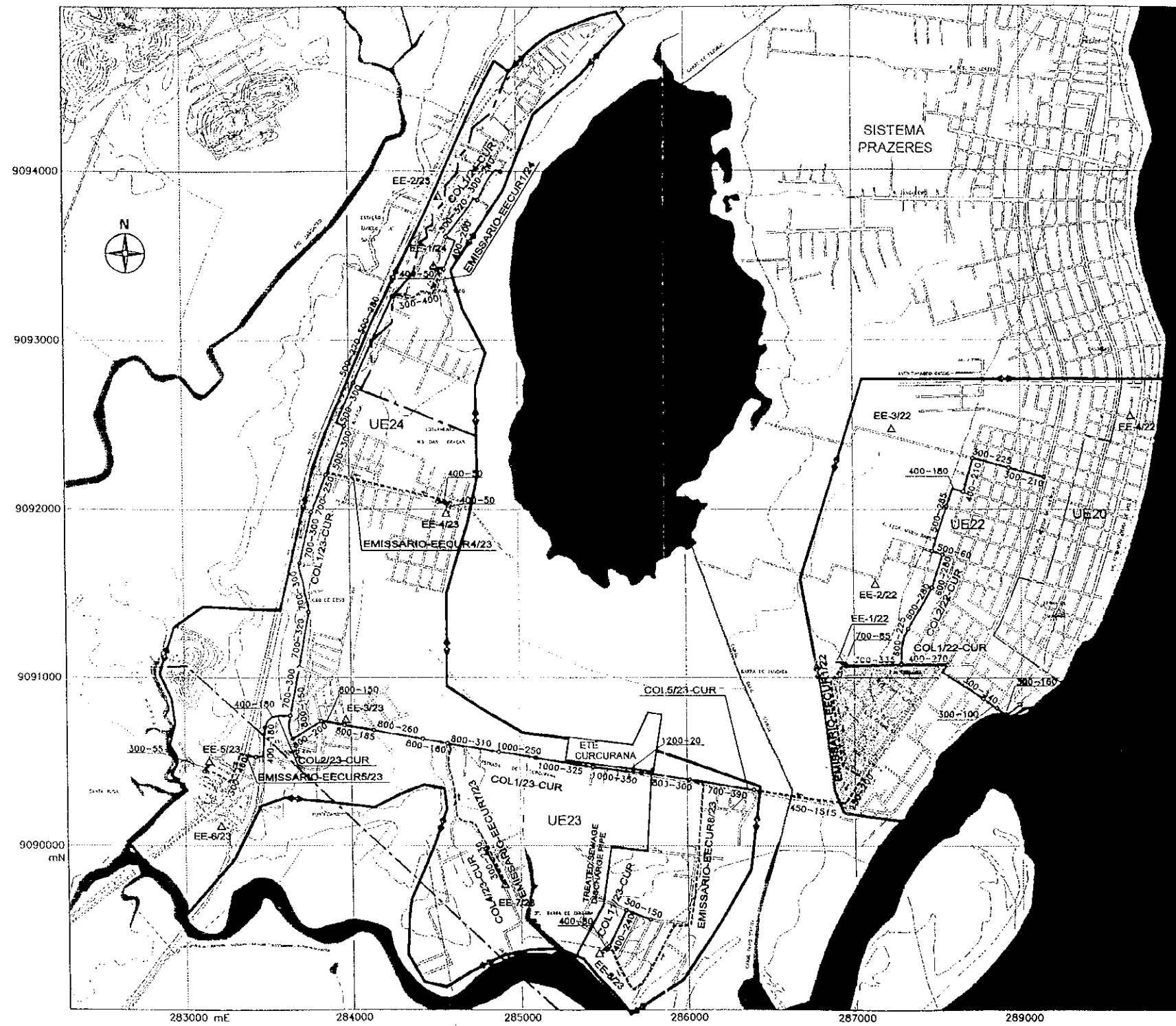

Fig. A.4-8 Layout Plan of Curcurana System

THE STUDY ON STORMWATER DRAINAGE AND SEWERAGE MANAGEMENT PLAN FOR RMR



SCALE 1:30.000

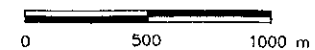
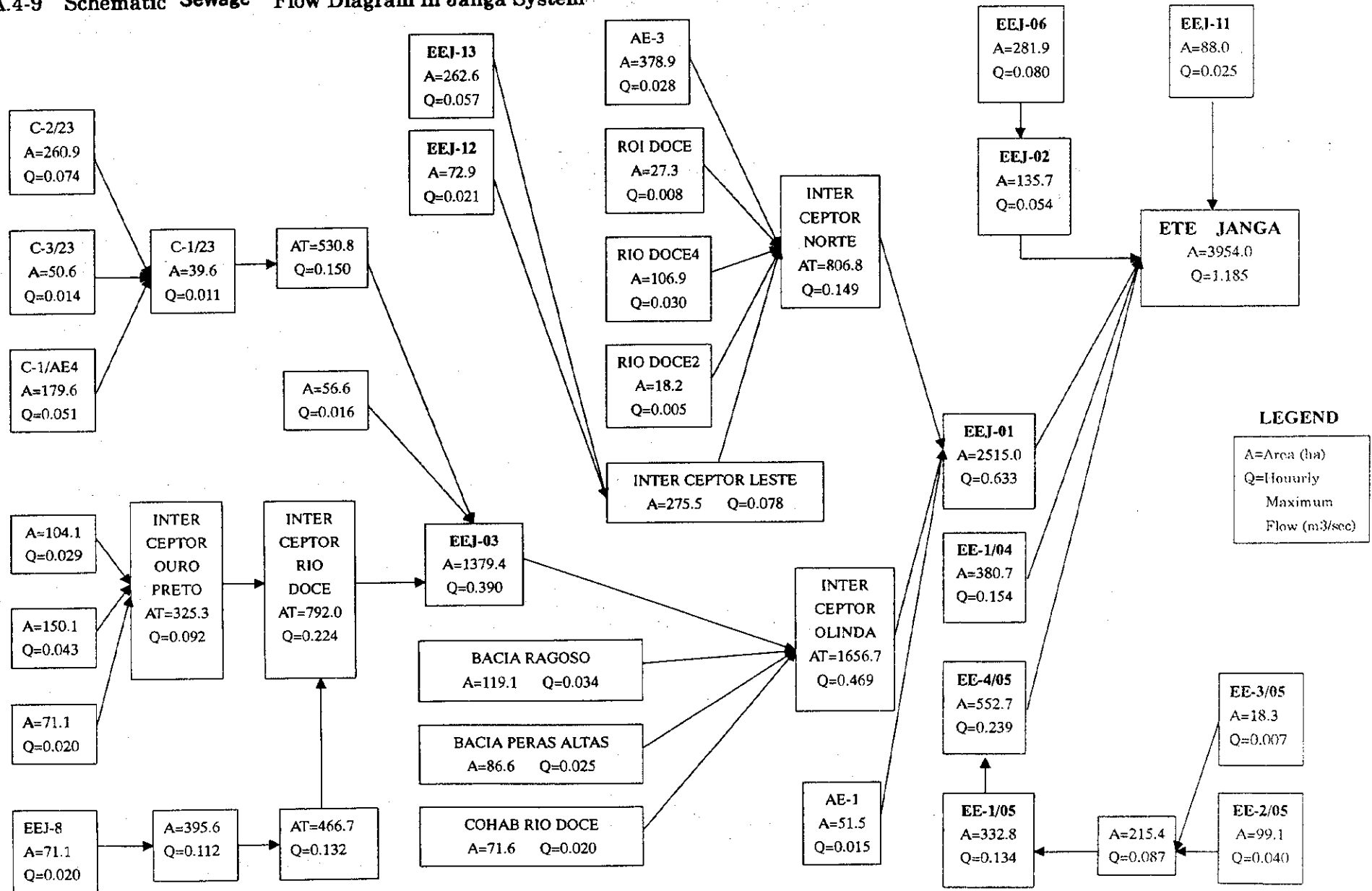

Fig. A.4-8

Layout Plan of Curcurana System

Fig. A.4-9 Schematic Sewage Flow Diagram in Janga System



LEGEND

A=Area (ha)
 Q=Hourly
 Maximum
 Flow (m³/sec)

Fig. A.4-10 Schematic Sewage Flow Diagram in Cabangá System

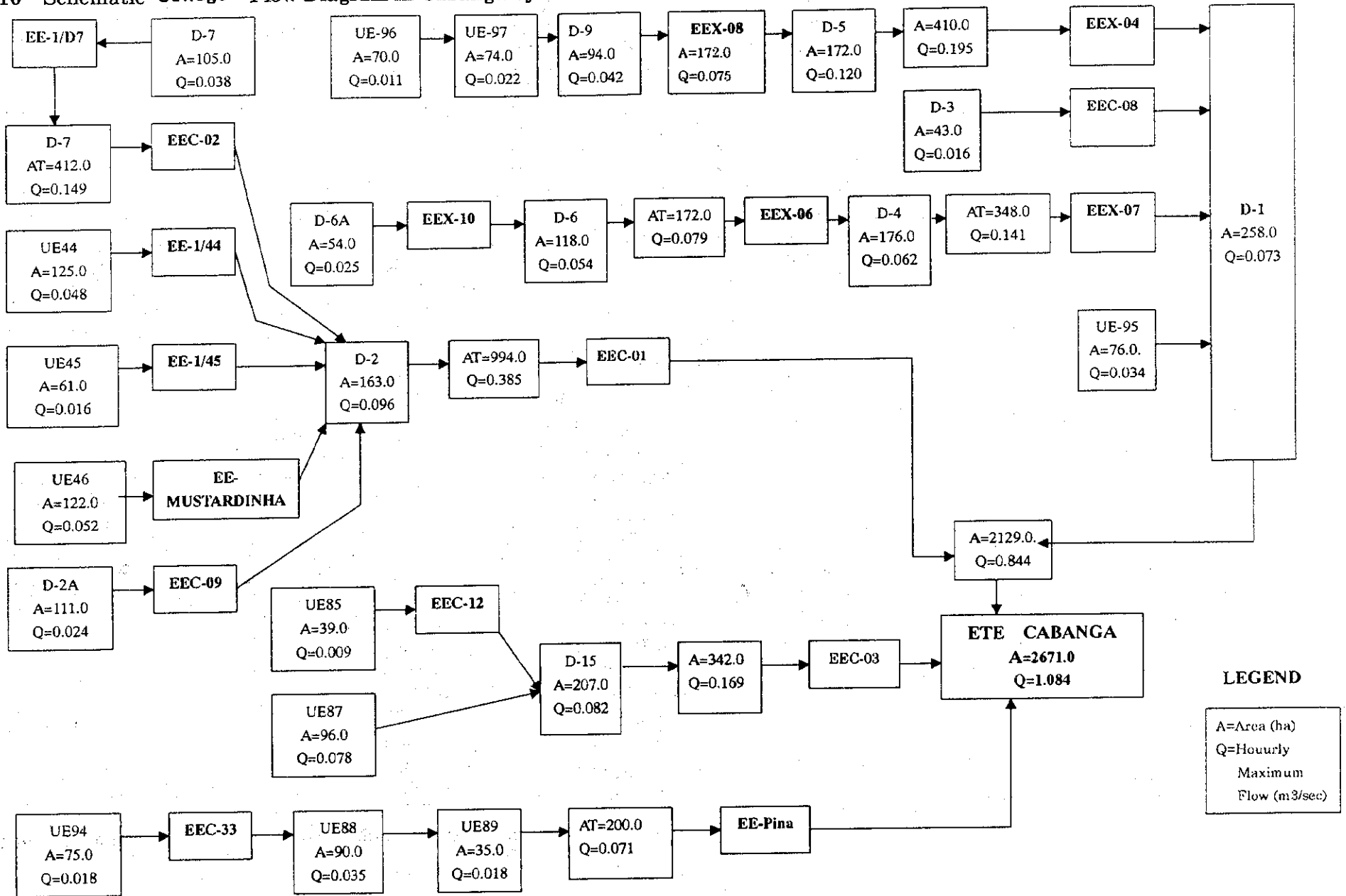

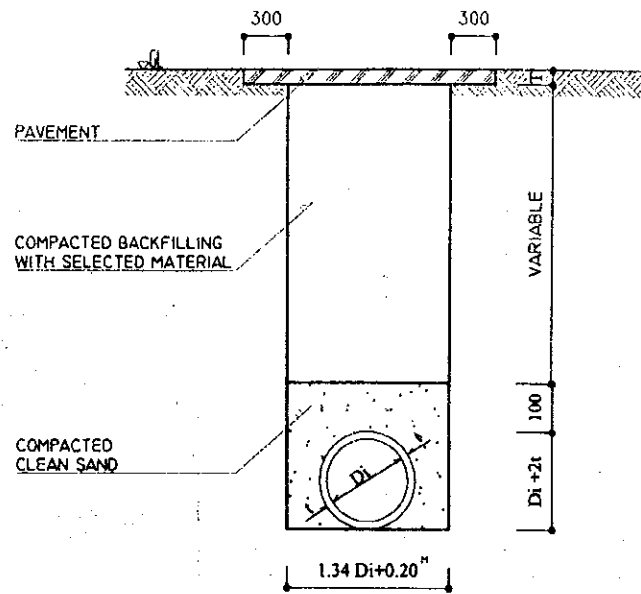

ON DRY,
FIRM SOIL

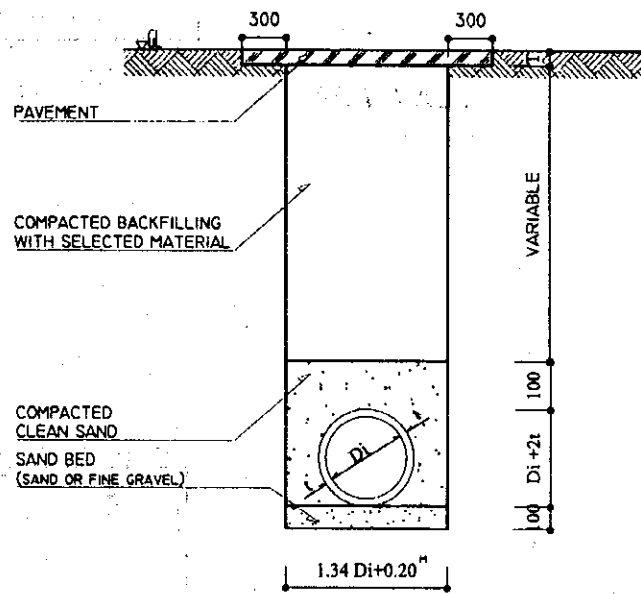

ON
ROCK SOIL

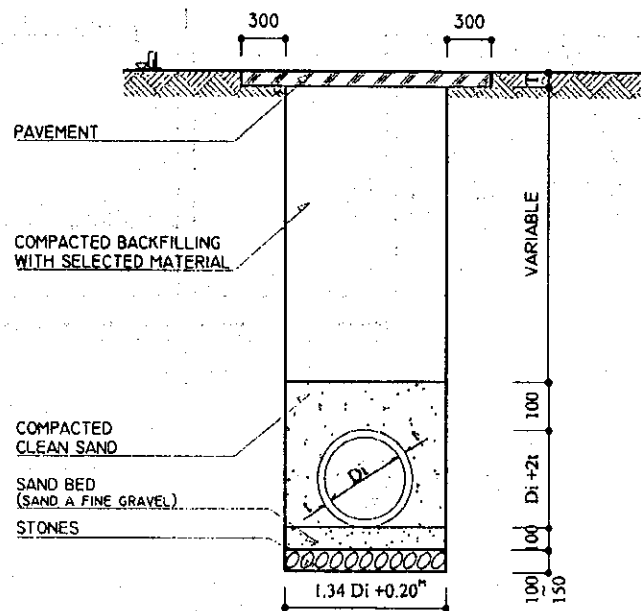

WITH WATER
LOGGED SOIL

Fig.A-4-11 Typical Cross Section for Trunk Sewer

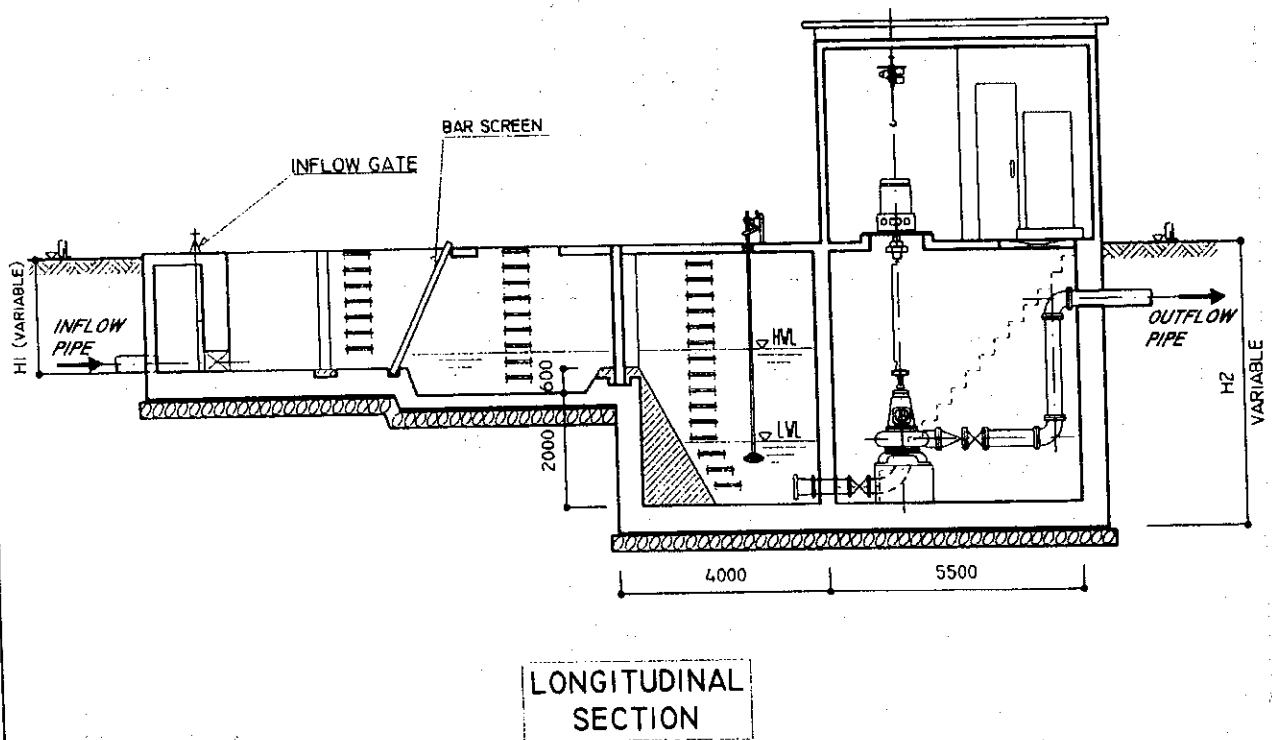
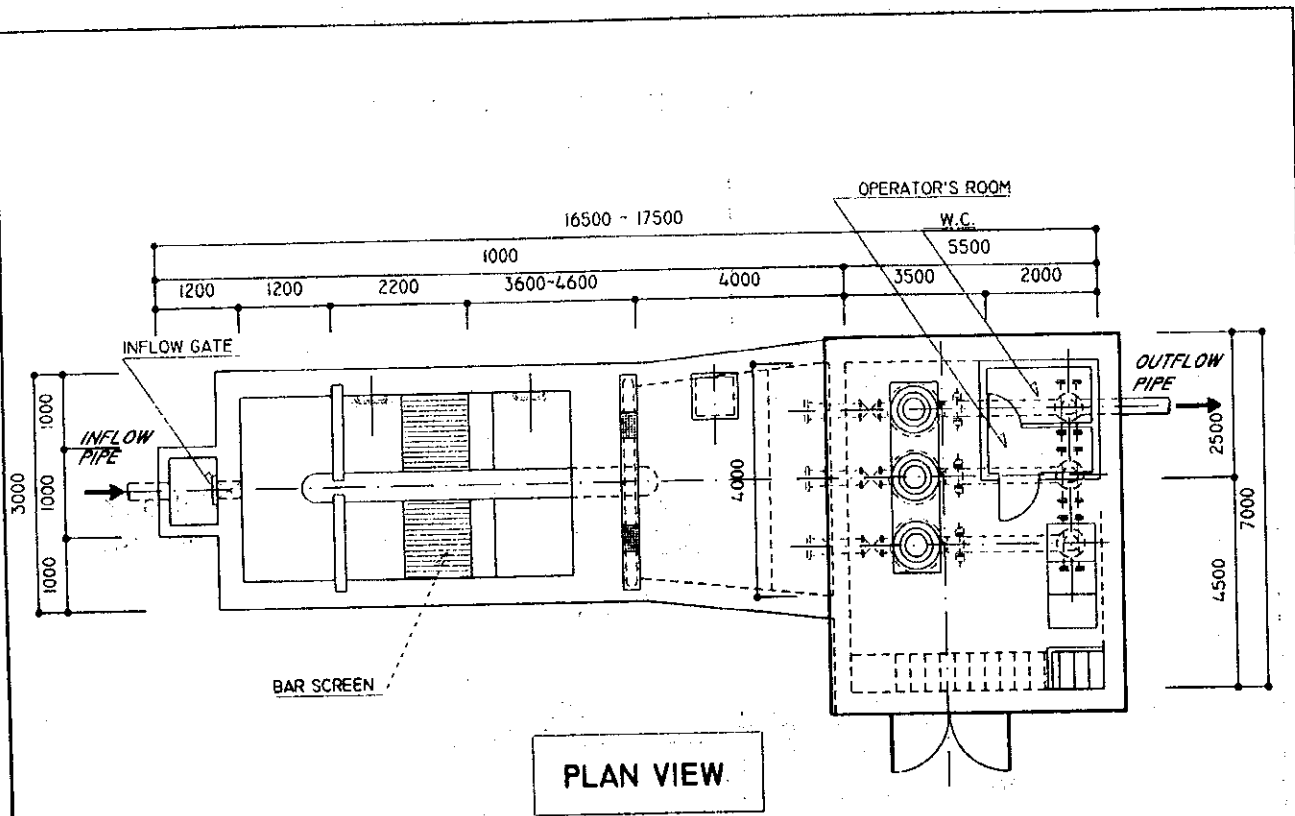

Fig.A-4-12 Standard Type Pumping Station (I)

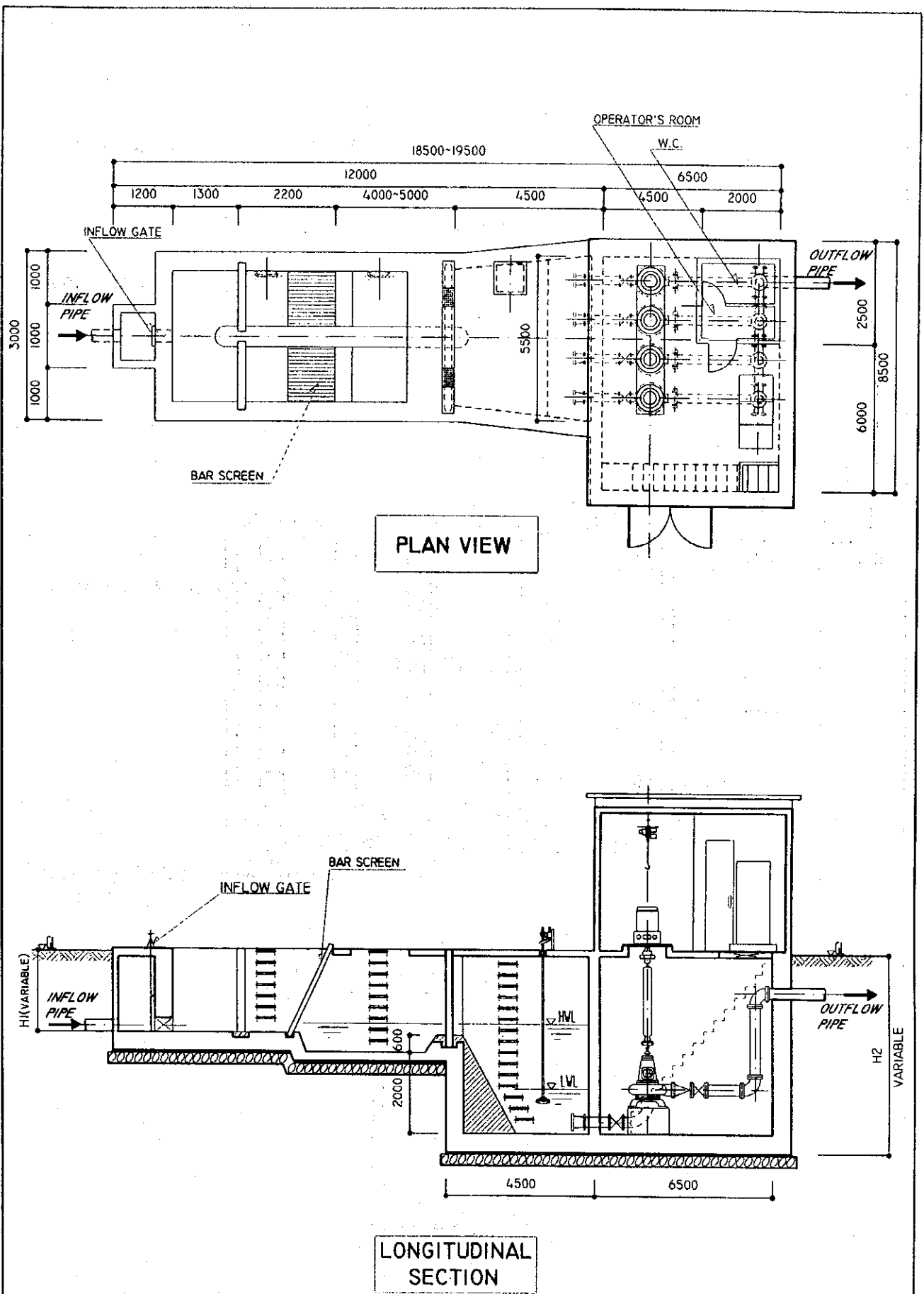

Fig.A-4-13

Standard Type Pumping Station (II)

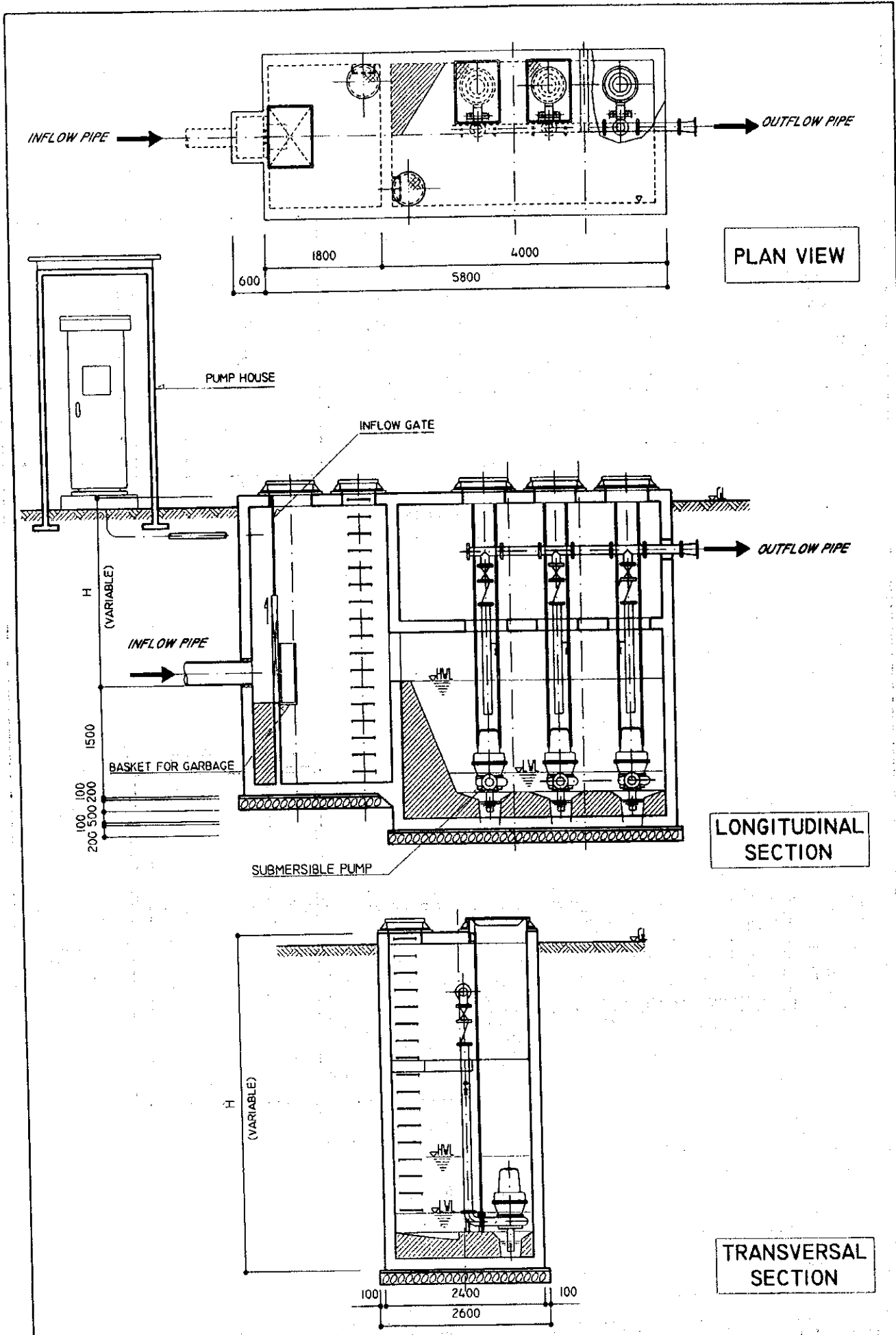

Fig.A-4-14 Simplified Type Pumping Station (I)

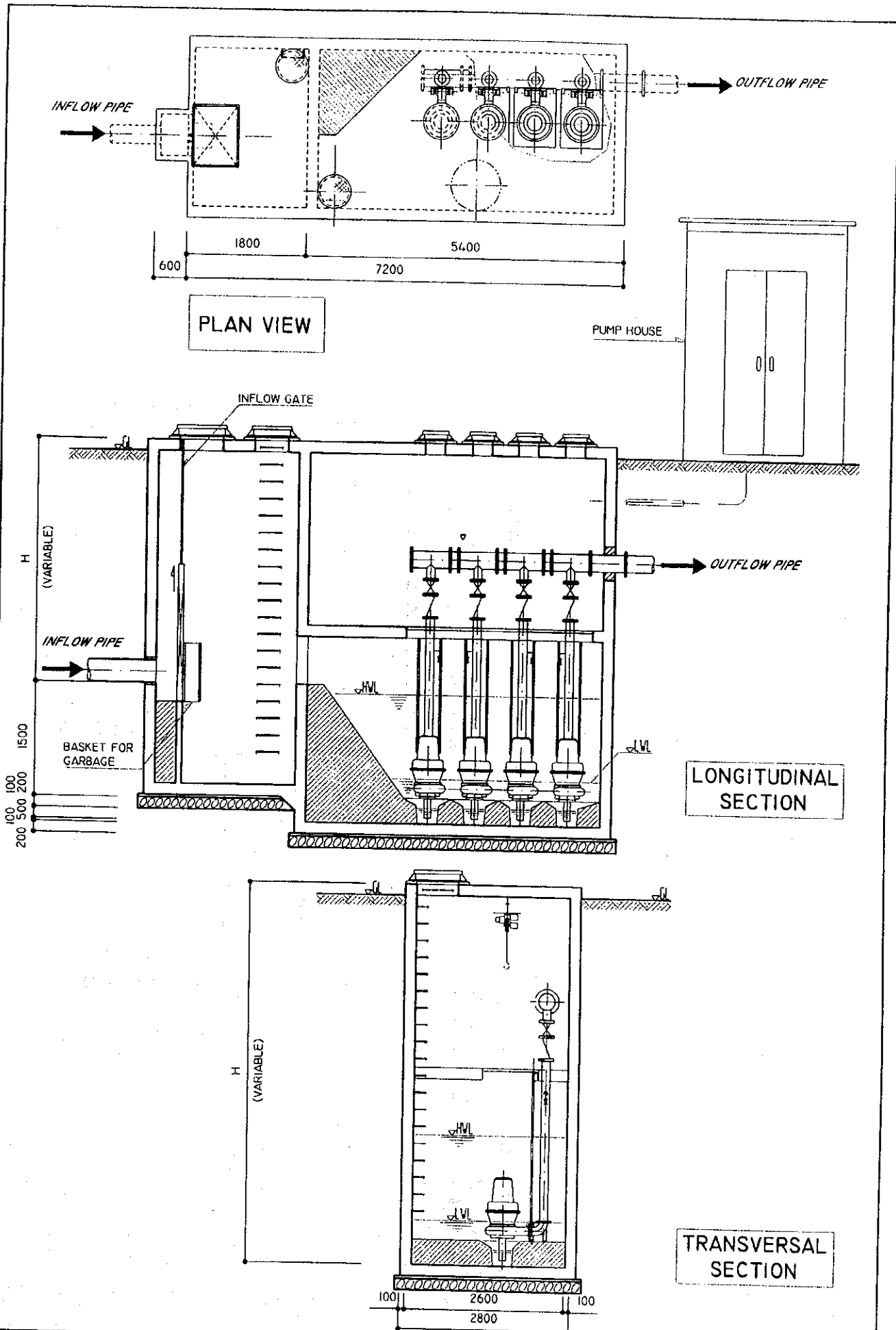

Fig.A-4-15 Simplified Type of Pumping Station (II)

THE STUDY ON STORMWATER DRAINAGE AND SEWERAGE MANAGEMENT PLAN FOR RMR

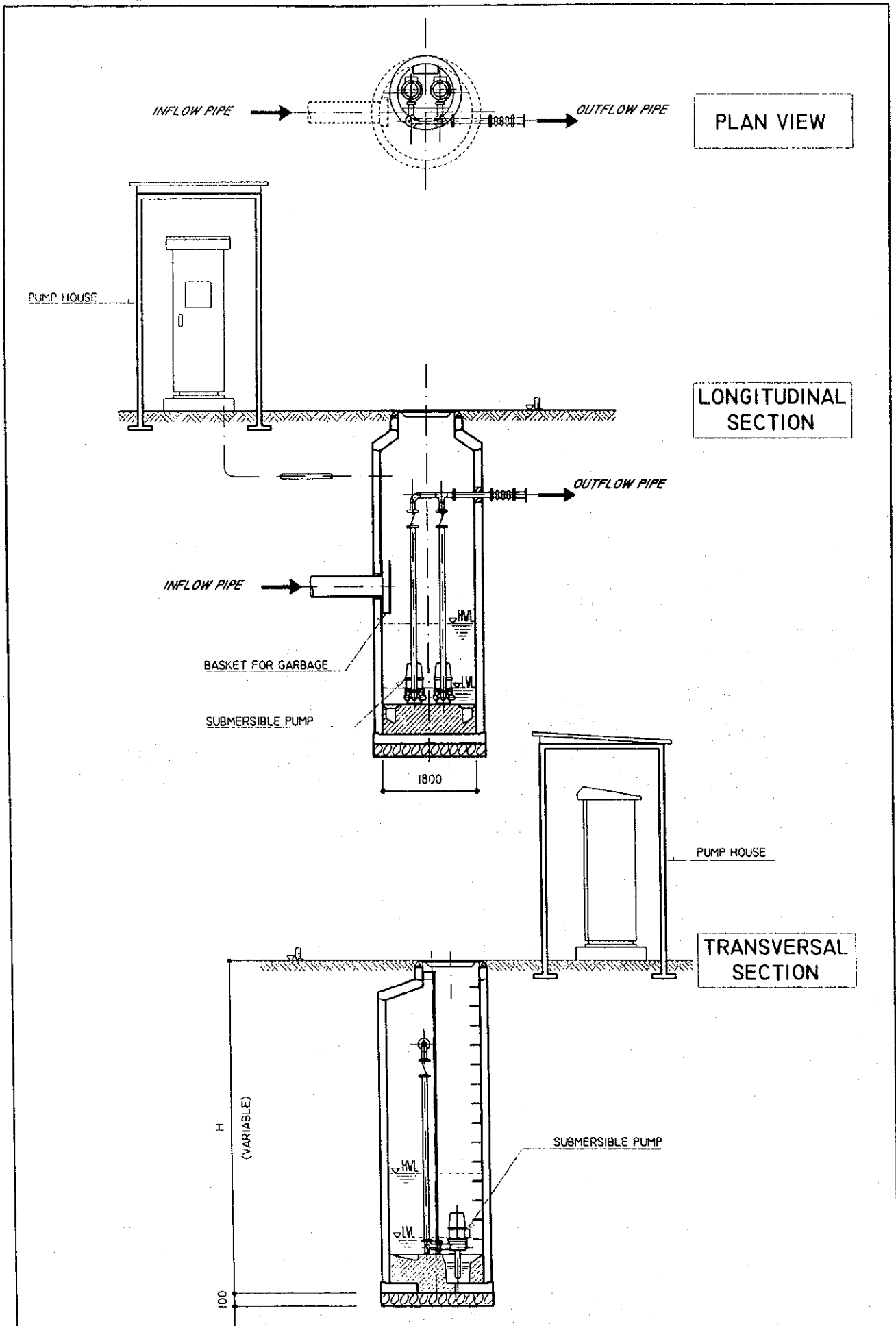

Fig.A-4-16 Manhole Type of Pumping Station

Fig.A.4-17 Flow Diagram of Existing Janga Sewerage System

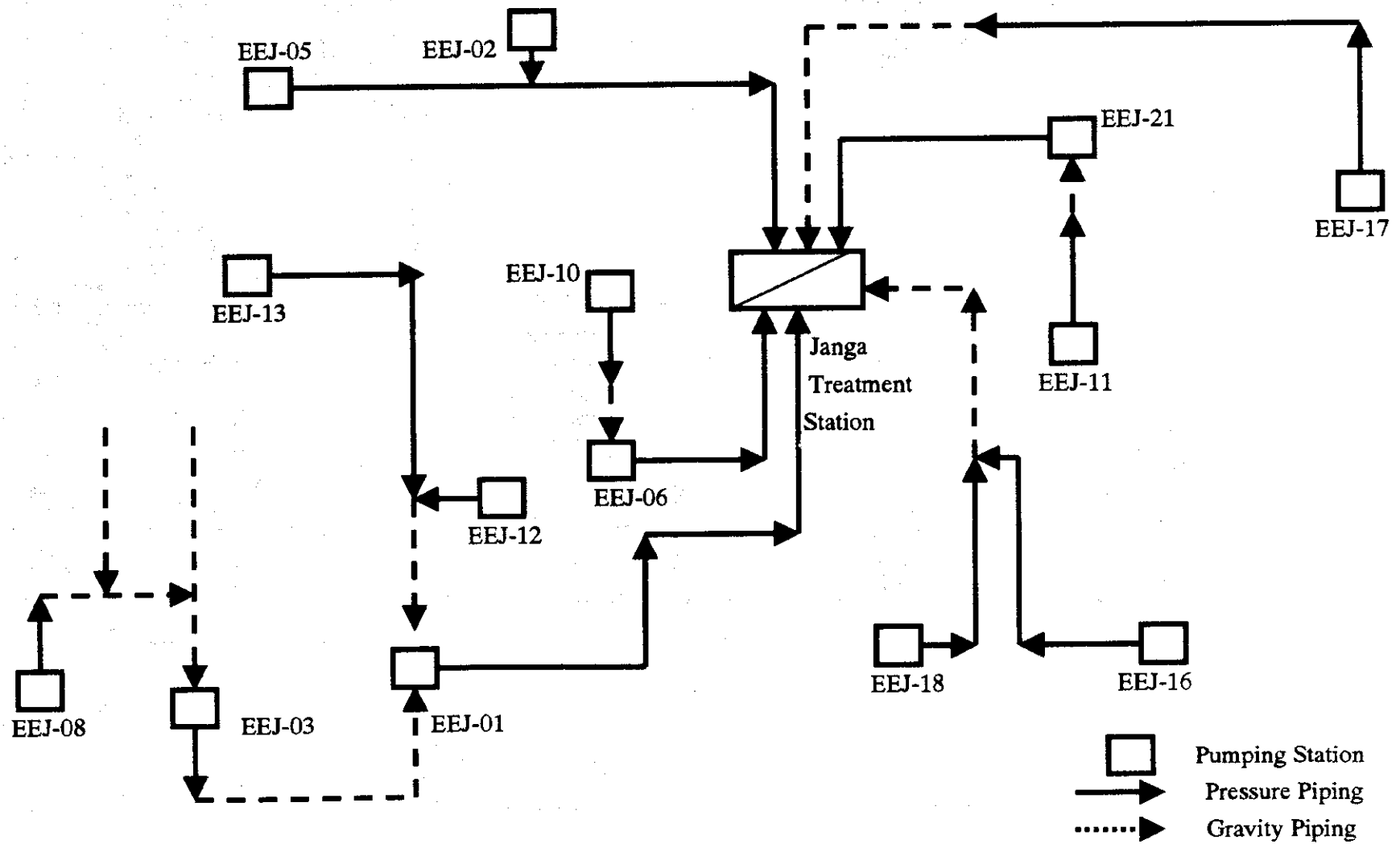
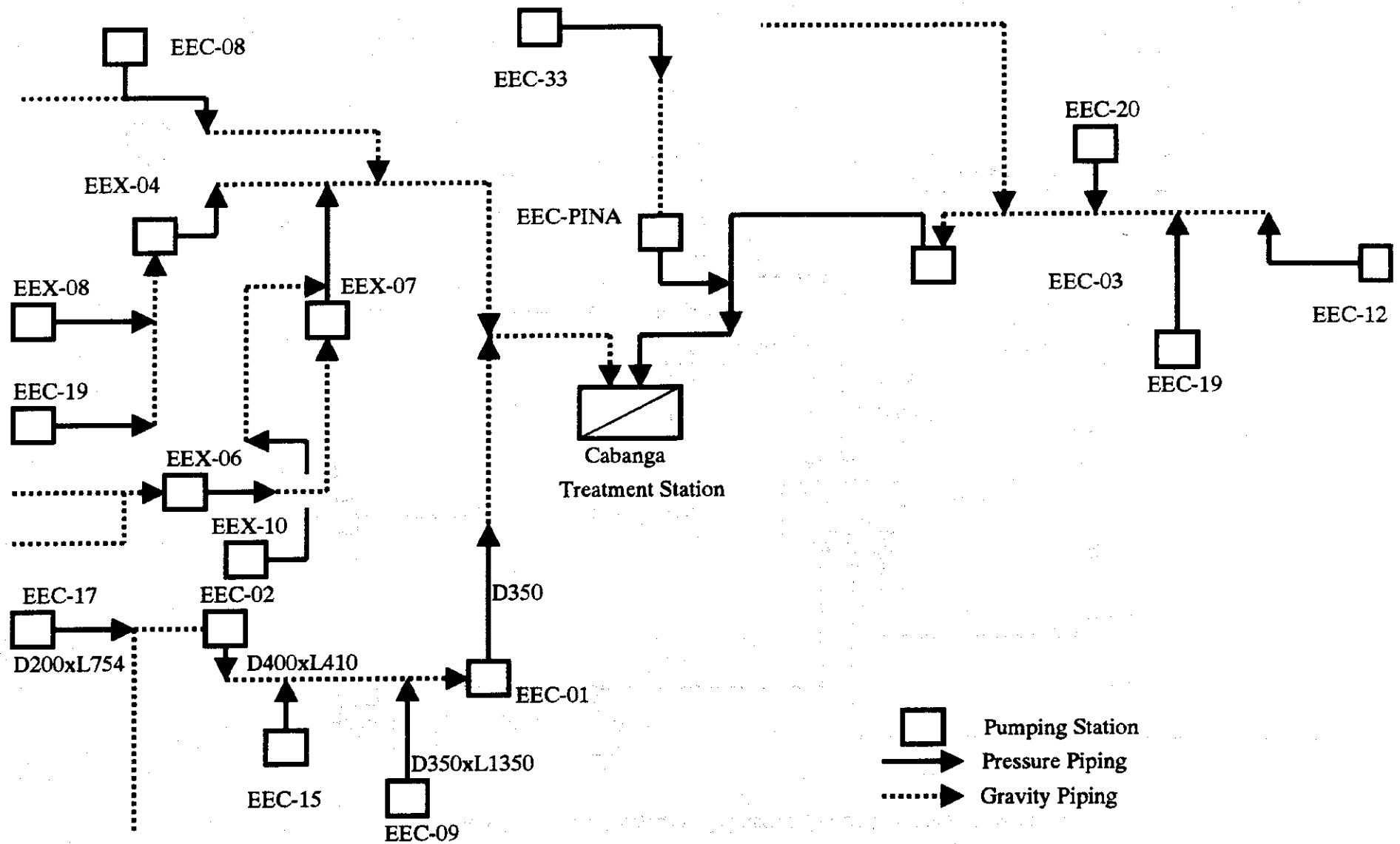





Fig.A.4-18 Flow Diagram of Existing Cabanga Sewerage System



A - 144

-  Pumping Station
-  Pressure Piping
-  Gravity Piping