



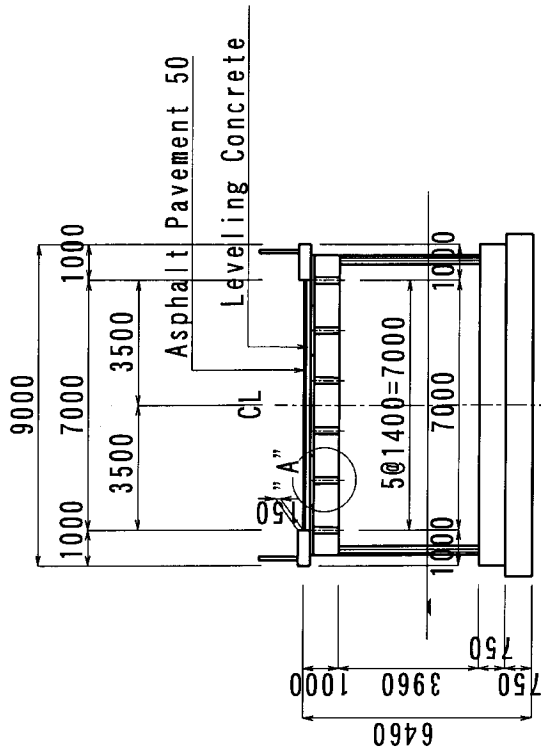
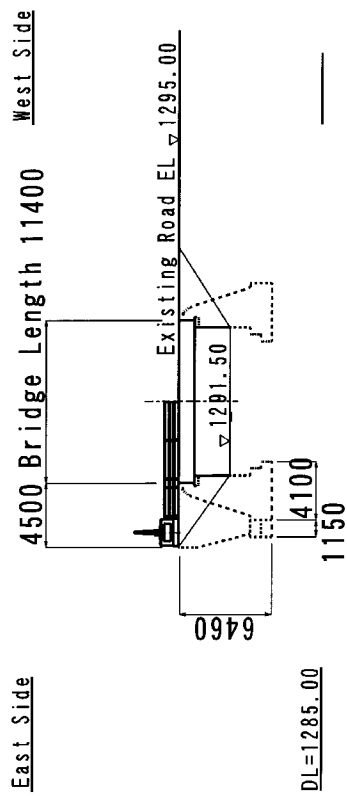

Table-B Photo for Existing Conditions of Bridge (No.2-2)

Kind	1. Road	2. Bridge	Investigated on Location	Photo by
		<p>Comments East abutment. Destruction, spalling at shoe beds None shoes</p>		<p>Comments West abutment. Same as East abutment Overage of all concrete structures</p>
		<p>Comments Upstream side. Made parking area of Market in 1999 at river No function of river, only drainage for rainfall from park</p>		<p>Comments Railway bridge at downstream. No revetment at downstream side No revetment at downstream side</p>

General View Of Existing New Market South Bridge  
(14th Khoroolol Bridge)



Cross Section  
S=1/200

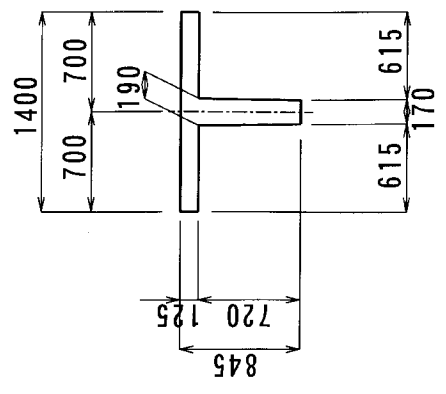

Detail "A"  
S=1/50

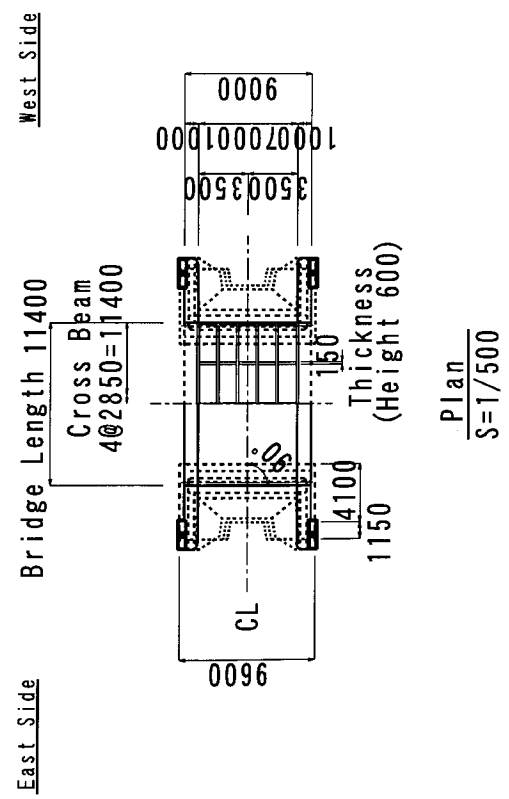



A: SECTION OF WESTERN RAILWAY CROSSING (F/0)

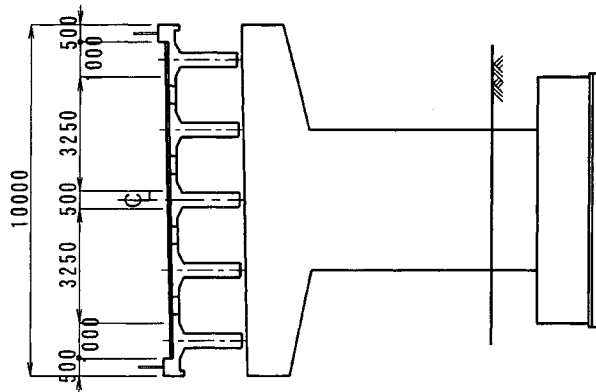

Bridge Section

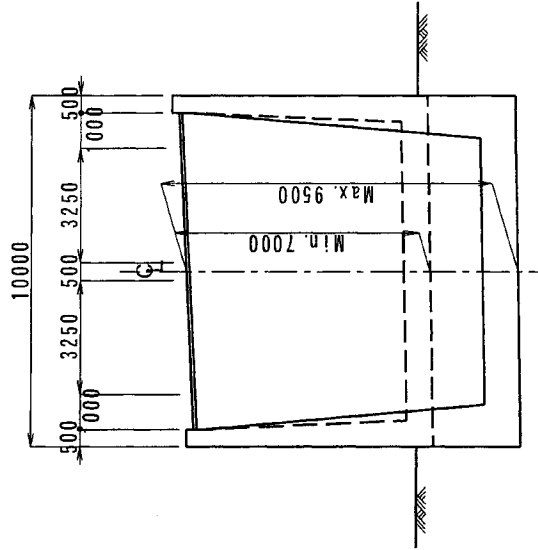

Retaining Wall Section



A' : SECTION OF WESTERN RAILWAY CROSSING (U/P)

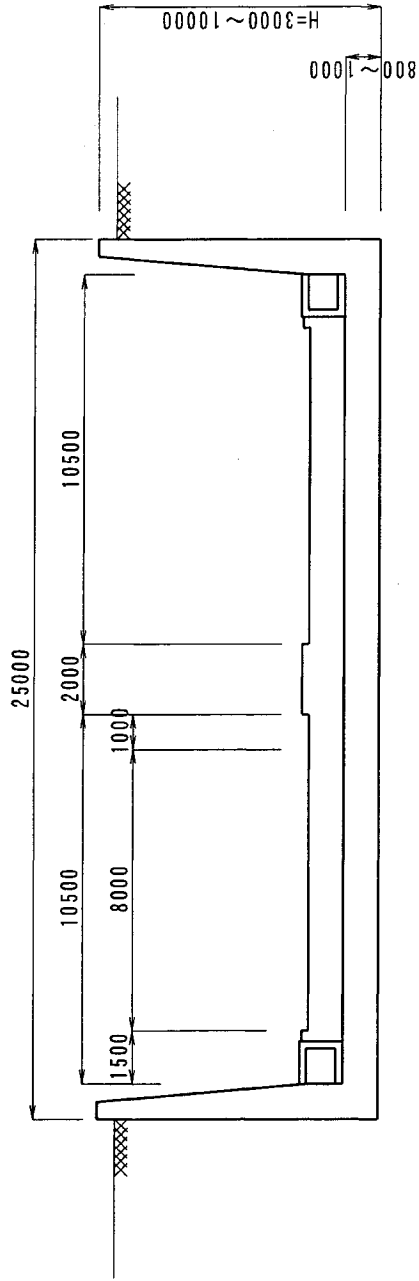

U-Shape Retaining Wall Section

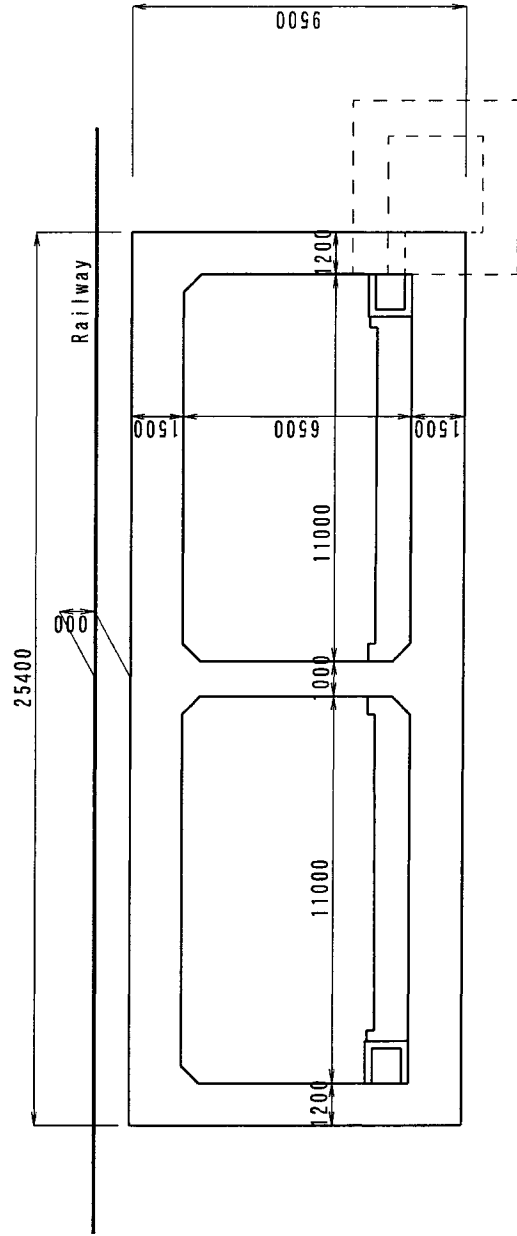

Box Culvert Section

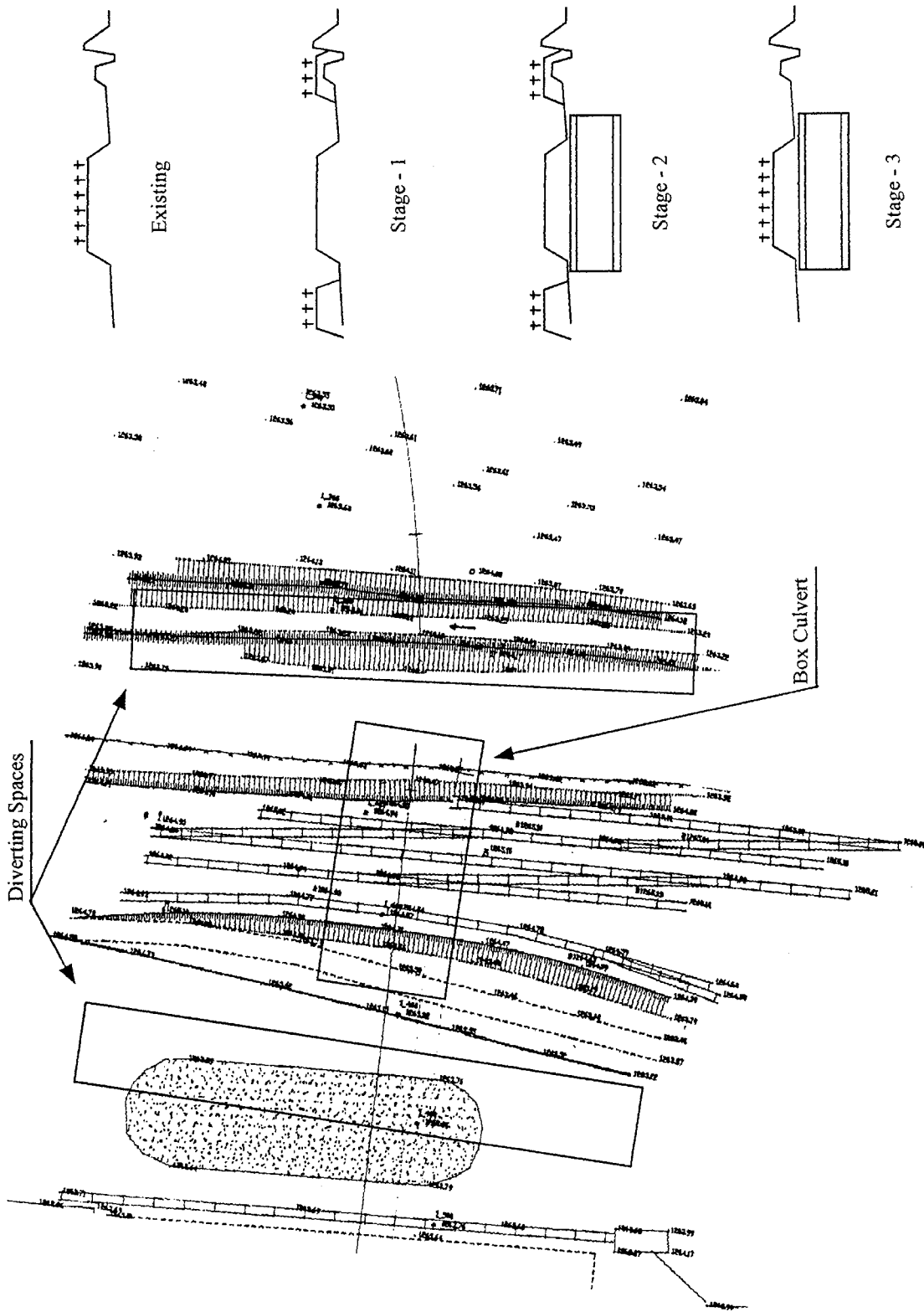

B : GENERAL VIEW OF EAST CROSS (F/0)

PROFILE H=1:3000  
Scale V=1:400

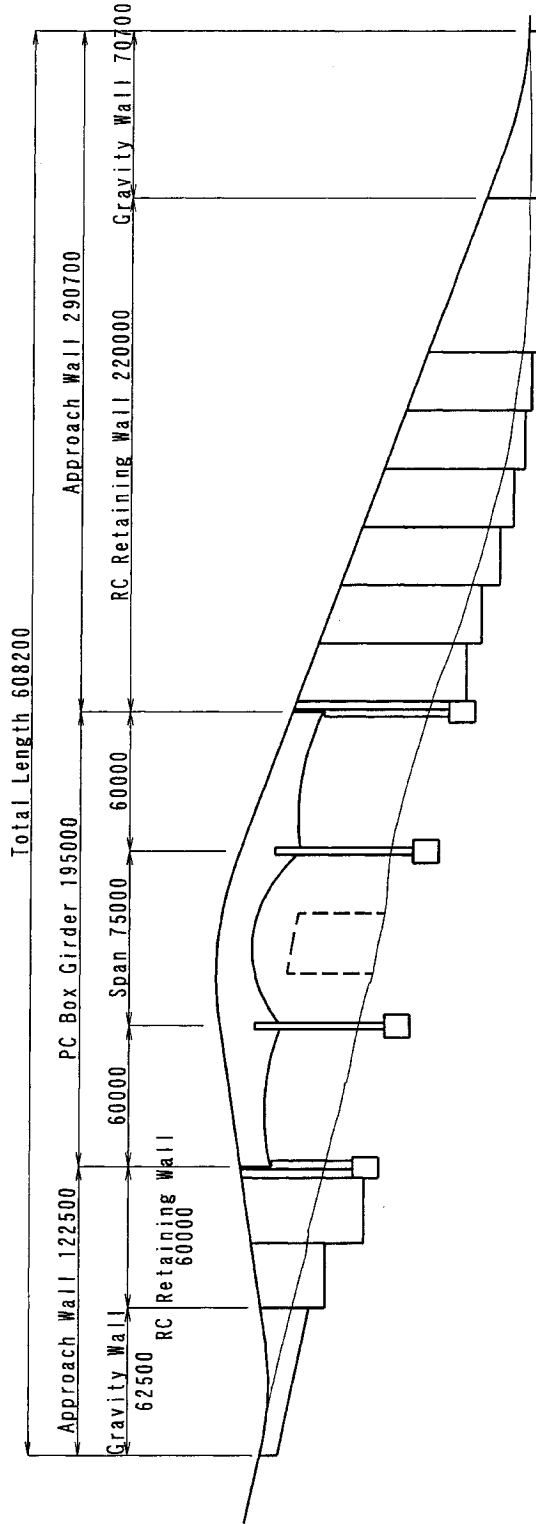

PLAN Scale 1:3000

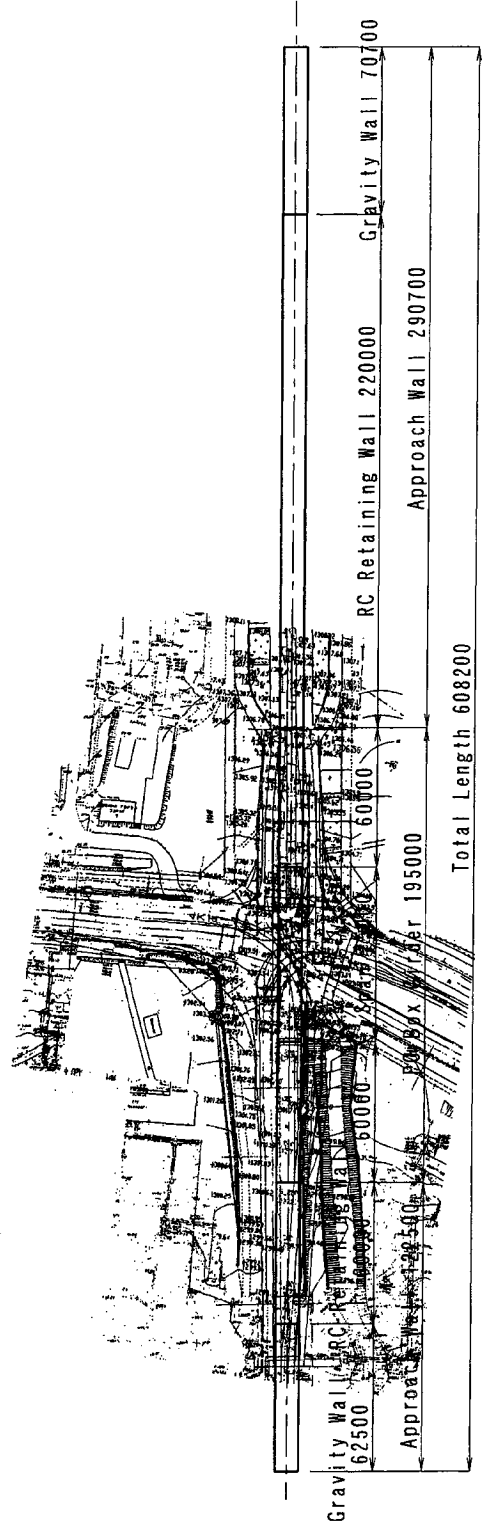



B : SECTION OF EAST CROSS (F/0)

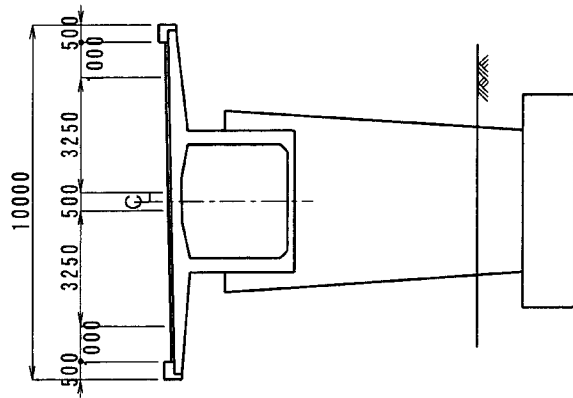

Bridge Section

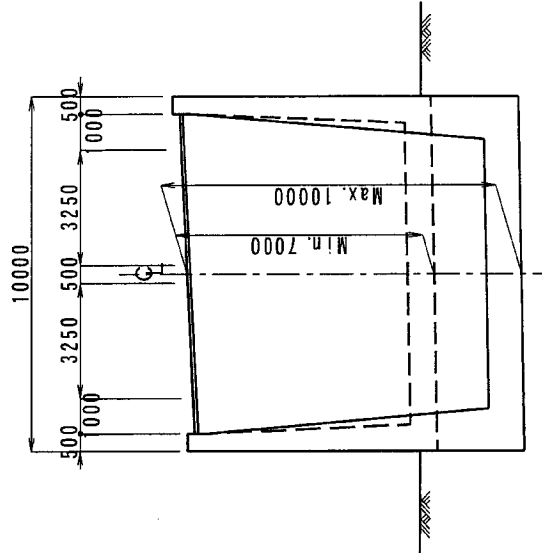

Retaining Wall Section

C : GENERAL VIEW OF WEST CROSS (F/0)

PROFILE  
H=1:2000  
Scale V=1:400

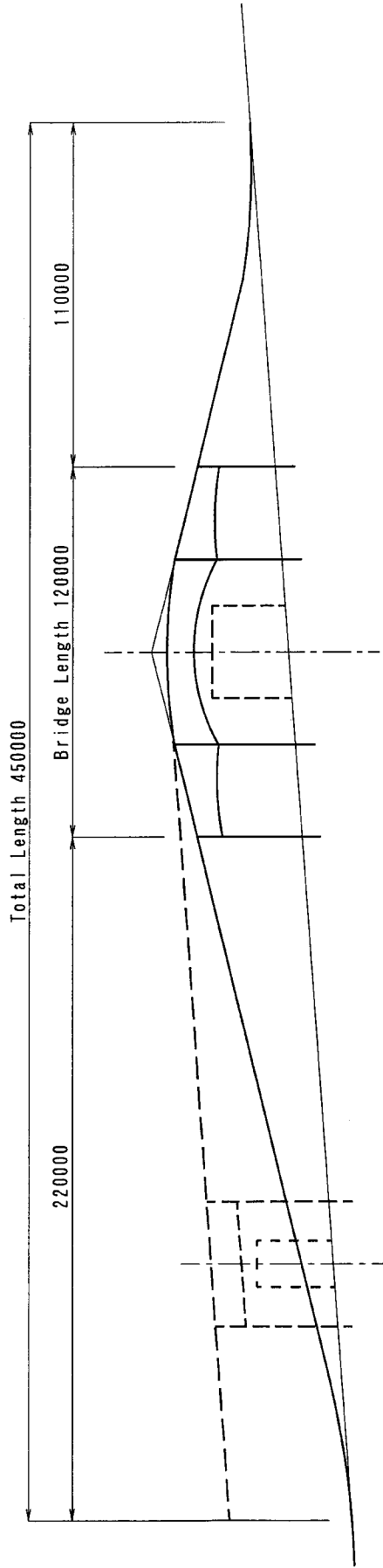

PLAN Scale 1:5000

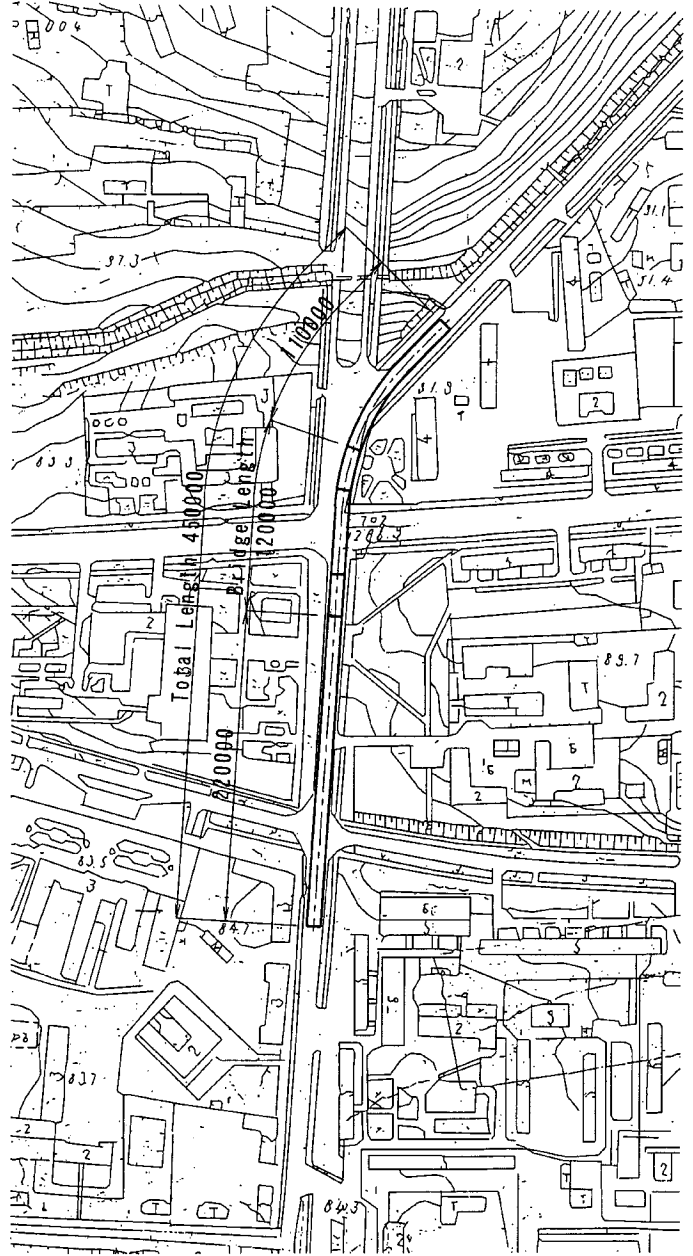

D : GENERAL VIEW OF WEST TEEVERCHID (F/0)

PROFILE H=1:2000  
Scale V=1:400

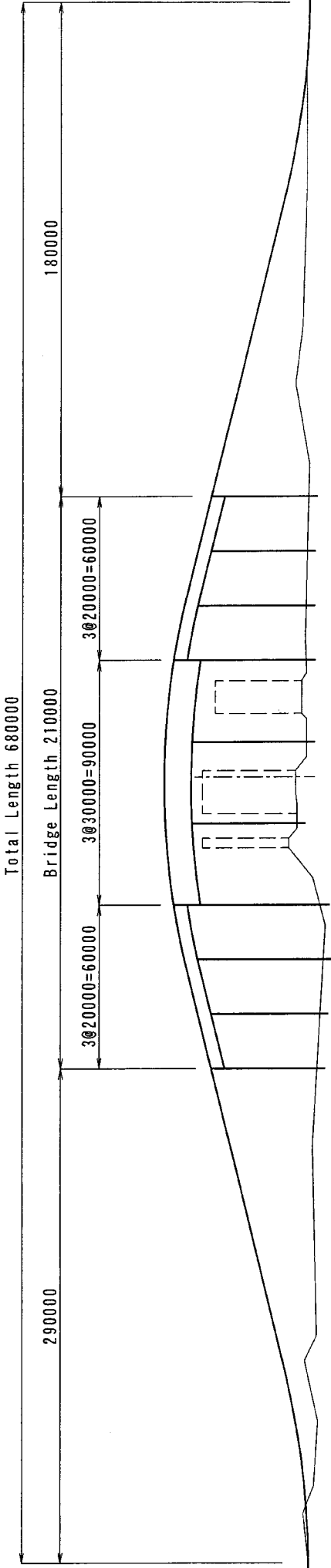

PLAN Scale 1:5000

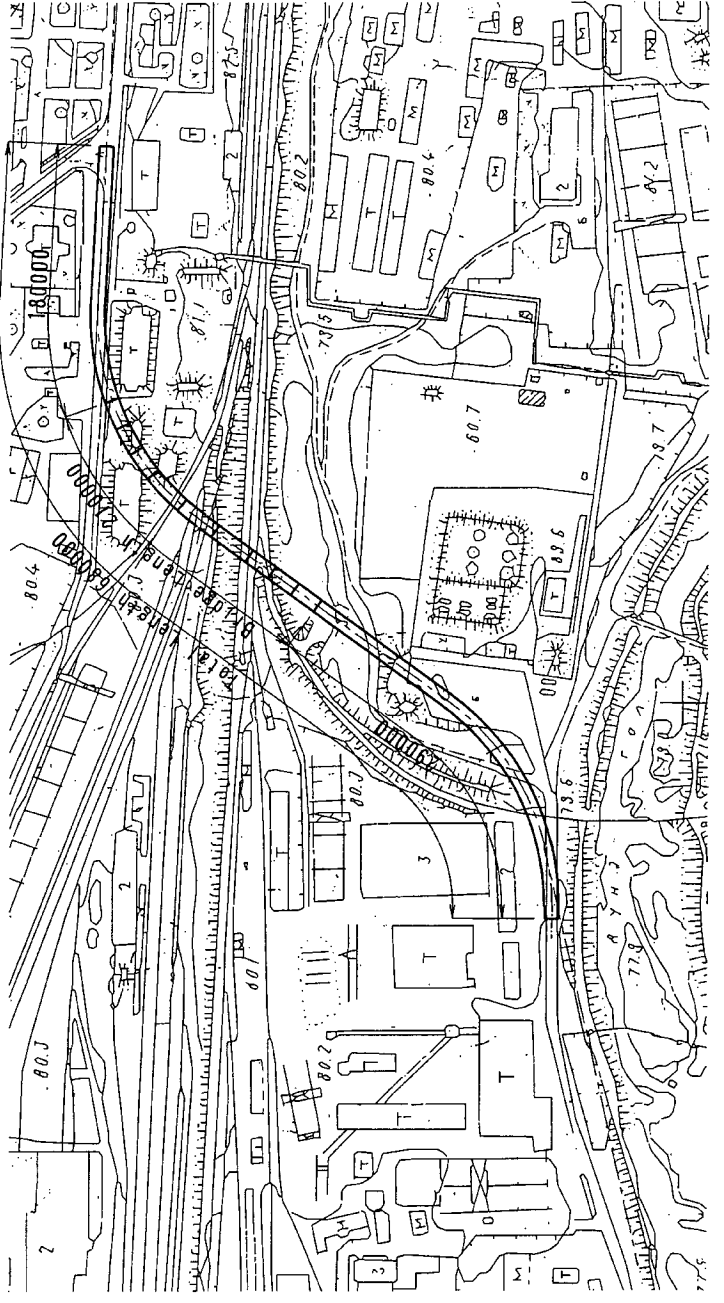

E: GENERAL VIEW OF NEW CENTRAL MARKET (F/0)

H=1:2000  
Scale V=1:400

PROFILE

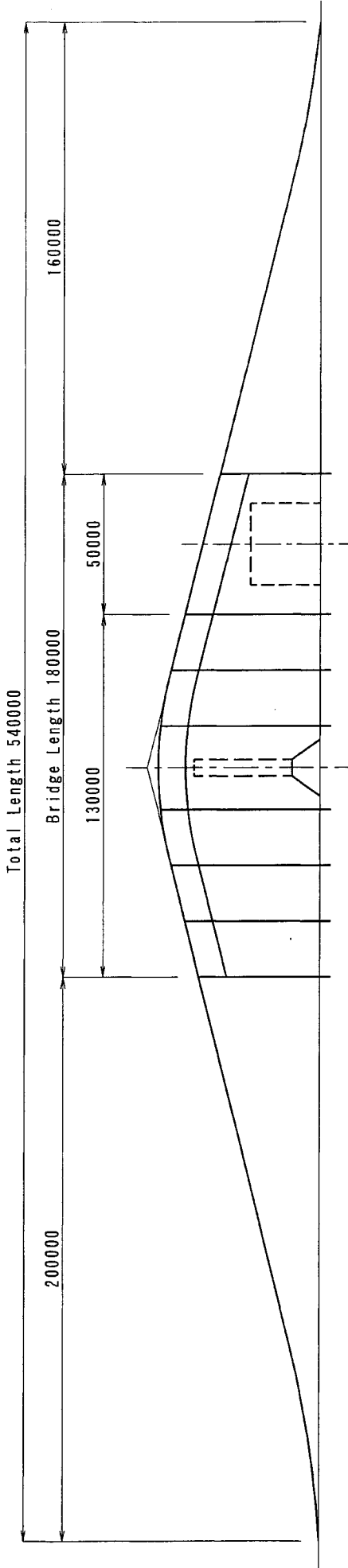

PLAN Scale 1:5000

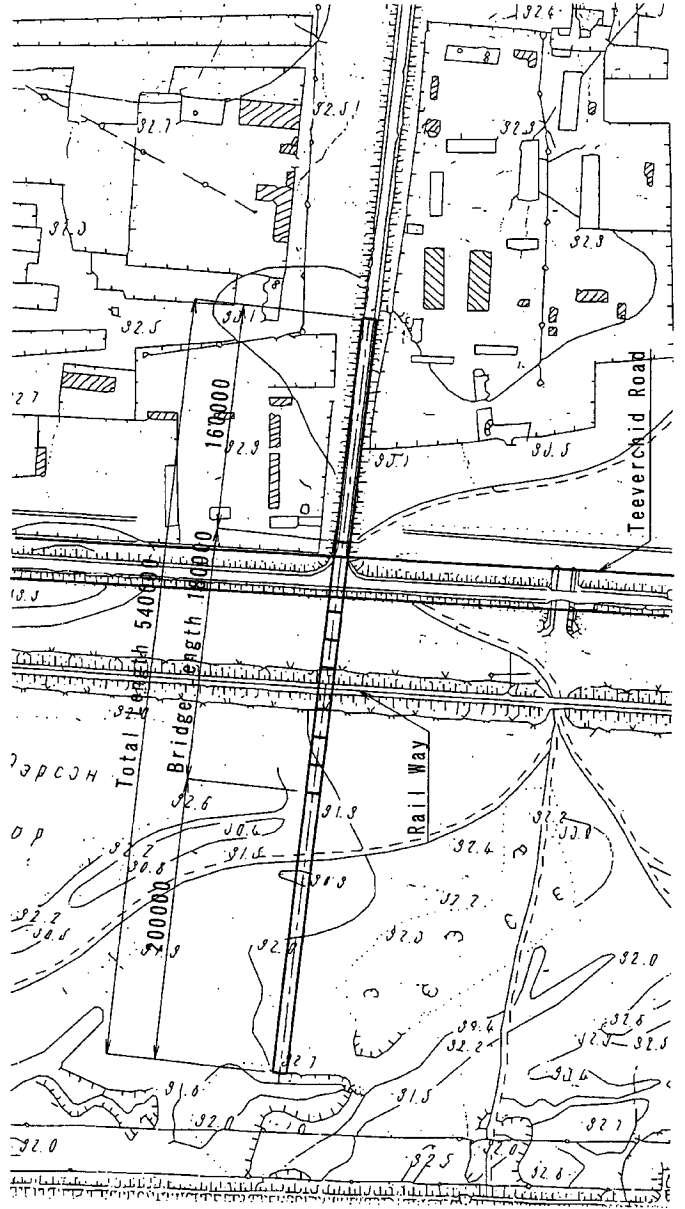

## **6-6: Equipment List**

**Table-1 EQUIPMENT LIST OF THE “ERDENE ZAM” COMPANY (State Owned)**

No	Equipment	Model	Specification	Q-ty	Country of manufacture	Produced year	Present condition	Location	Service meter	
									Motor/hour	Km
1	Excavator	CAT-330	1.4m <sup>3</sup>	1	USA	1996	Operatable	Sharin-Gol		
2	Excavator	CAT-320	0.65m <sup>3</sup> No1	1	USA	1996	Operatable	Arkhangai, Ikh Tamir	4.442	
3	Excavator	CAT-320	0.65m <sup>3</sup> No2	1	USA	1996	Operatable	Khutel		
4	Excavator	CAT-320	0.65m <sup>3</sup> No3	1	USA	1996	Operatable	UB		
5	Excavator	CAT-320	0.65m <sup>3</sup> No4	1	USA	1996	Operatable	Arkhangai, Ikh Tamir		
6	Excavator	CAT-320	0.65m <sup>3</sup> No5	1	USA	1996	Operatable	Arkhangai, Ikh Tamir	2.712	
7	Excavator	CAT-320	0.65m <sup>3</sup> No6	1	USA	1996	Operatable	Sharin-Gol		
8	Tractor shovel	CAT-938F	2.1m <sup>3</sup> No1	1	USA	1996	Operatable	UB-Baga Nuur		
9	Tractor shovel	CAT-938F	2.1m <sup>3</sup> No2	1	USA	1996	Operatable	Arkhangai, Ikh Tamir		
10	Tractor shovel	CAT-910F	1.2m <sup>3</sup> No1	1	USA	1996	Operatable	UB		
11	Tractor shovel	CAT-910F	1.2m <sup>3</sup> No2	1	USA	1996	Operatable	Arkhangai, Ikh Tamir	4.132	
12	Crawler-Drill	HCR-9DS	Hydraulic 180 kg	1	Japan	1996	Operatable	UB	330	
13	Hydraulic Breaker	H10XB	Hydraulic 130 kg	1	Japan	1996	Operatable	UB		
14	Vibration-Roller	CA-251STD	10 ton	1	Japan	1996	Operatable	Arkhangai, Ikh Tamir	3.840	
15	Tire-Roller	CP-201	10 ton (No1)	1	Japan	1996	Operatable	UB	2.160	
16	Tire-Roller	CP-201	10 ton (No2)	1	Japan	1996	Operatable	UB	2.460	9.404
17	Macadam Roller	CS-12	10 ton (No1)	1	Japan	1996	Operatable	UB	2.239	
18	Macadam Roller	CS-12	10 ton (No2)	1	Japan	1996	Under repair	UB		
19	Bulldozer	D-155A	32 ton	1	Japan	1996	Operatable	Sharin Gol		
20	Bulldozer	D-85A21	21 ton No1	1	Japan	1996	Operatable	Sharin Gol		
21	Bulldozer	D-85A21	21 ton No2	1	Japan	1996	Operatable	Arkhangai, Ikh Tamir	4.229	
22	Bulldozer	D-655E12	15 ton	1	Japan	1996	Operatable	UB		
23	Motor-Grader	GD-511A1	3.7 m No 1	1	Japan	1996	Operatable	Arkhangai, Ikh Tamir	5.076	
24	Motor-Grader	GD-511A1	3.7 m No 2	1	Japan	1996	Under repair	UB		
25	Asphalt-finisher	NF-130VDM	2.5-4.5 m	1	Japan	1996	Operatable	UB		
26	Water-lorry	FF-3HJSA	6000 l No1	1	Japan	1996	Operatable	UB		60.000
27	Water-lorry	FF-3HJSA	6000 l No2	1	Japan	1996	Operatable	Arkhangai, Ikh Tamir		68.810
28	Fuel-lorry	FF-3HJSA	6000 l No1	1	Japan	1996	Operatable	Arkhangai, Ikh Tamir		53.368
29	Fuel-lorry	FF-3HJSA	6000 l No2	1	Japan	1996	Operatable	UB		56.546

No	Equipment	Model	Specification	Q-ty	Country of manufacture	Produced year	Present condition	Location	Service meter	
									Motor/hour	Km
30	Crane	FH-224SA	8 ton	1	Japan	1996	Operatable	Arkhangai, Ikh Tamir		
31	Crane	TL-250E	25 ton	1	Japan	1996	Operatable	Arkhangai, Ikh Tamir	2.369	18.931
32	Trailer	SS-633	30 ton	1	Japan	1996	Operatable	UB		70.178
33	Mobile work-shop	HZ-227SA	No1	1	Japan	1996	Operatable	UB		37.220
34	Mobile work-shop	HZ-227SA	No2	1	Japan	1996	Operatable	Arkhangai, Ikh Tamir		100.000
35	Dump-truck	KY-220	11 ton	1	Japan	1996	Operatable	UB		160.000
36	Dump-truck	KY-220	11 ton	1	Japan	1996	Operatable	Sharin Gol		
37	Dump-truck	KY-220	11 ton	1	Japan	1996	Operatable	Sharin Gol		
38	Dump-truck	KY-220	11 ton	1	Japan	1996	Operatable	Arkhangai, Ikh Tamir		140.000
39	Dump-truck	KY-220	11 ton	1	Japan	1996	Operatable	UB		
40	Dump-truck	KY-220	11 ton	1	Japan	1996	Operatable	Sharin Gol		
41	Dump-truck	KY-220	11 ton	1	Japan	1996	Operatable	UB		
42	Dump-truck	KY-220	11 ton	1	Japan	1996	Operatable	UB		87.070
43	Dump-truck	KY-220	11 ton	1	Japan	1996	Operatable	UB, Baga Nuur		
44	Dump-truck	KY-220	11 ton	1	Japan	1996	Operatable	Arkhangai, Ikh Tamir		120.000
45	Dump-truck	KY-220	11 ton	1	Japan	1996	Operatable	Sharin Gol		
46	Dump-truck	KY-220	11 ton	1	Japan	1996	Operatable	Arkhangai, Ikh Tamir		100.000
47	Dump-truck	KY-220	11 ton	1	Japan	1996	Operatable	Arkhangai, Ikh Tamir		
48	Dump-truck	KY-220	11 ton	1	Japan	1996	Operatable	Sharin Gol		
49	Dump-truck	KY-220	11 ton	1	Japan	1996	Operatable	Sharin Gol		
50	Dump-truck	KY-220	11 ton	1	Japan	1996	Operatable	Sharin Gol		
51	Dump-truck	KY-220	11 ton	1	Japan	1996	Operatable	Arkhangai, Ikh Tamir		127.000
52	Dump-truck	KY-220	11 ton	1	Japan	1996	Operatable	UB		73.527
53	Dump-truck	KY-220	11 ton	1	Japan	1996	Operatable	Arkhangai, Ikh Tamir		100.000
54	Dump-truck	KY-220	11 ton	1	Japan	1996	Operatable	Sharin Gol		
55	Dump-truck	KY-220	11 ton	1	Japan	1996	Operatable	Arkhangai, Ikh Tamir		110.000
56	Dump-truck	KY-220	11 ton	1	Japan	1996	Operatable	UB		80.000
57	Dump-truck	KY-220	11 ton	1	Japan	1996	Operatable	UB		34.711
58	Dump-truck	KY-220	11 ton	1	Japan	1996	Operatable	UB		45.225
59	Dump-truck	KY-220	11 ton	1	Japan	1996	Operatable	Arkhangai, Ikh Tamir		170.000
60	Dump-truck	KY-220	11 ton	1	Japan	1996	Operatable	UB		

No	Equipment	Model	Specification	Q-ty	Country of manufacture	Produced year	Present condition	Location	Service meter	
									Motor/hour	Km
61	Dump-truck	KY-220	11 ton	1	Japan	1996	Operatable	Arkhangai, Ikh Tamir		100.000
62	Dump-truck	KY-220	11 ton	1	Japan	1996	Operatable	Arkhangai, Ikh Tamir		120.000
63	Dump-truck	KY-220	11 ton	1	Japan	1996	Operatable	UB		39.700
64	Electrical-generator	SD-6-60S	45KUA	1	Japan	1996	Operatable	Tuv, Erdene sum		
65	Electrical-generator	SD-6-60S	45KUA	1	Japan	1996	Operatable	Arkhangai, Ikh Tamir	4.541	
66	Electrical-generator	SD-6-60S	45KUA	1	Japan	1996	Operatable	Arkhangai, Ikh Tamir		
67	Electrical-generator	SD-6-60S	45KUA	1	Japan	1996	Operatable	Arkhangai, Ikh Tamir		
68	Electrical-generator	SD-6-60S	45KUA	1	Japan	1996	Operatable	UB		
69	Concrete mixer	PSM-18HE-FL	0.5 m <sup>3</sup>	1	Japan	1996	Operatable	UB		
70	Vibratory Plate Compacter	LF-110	110 kg	1	Japan	1996	Operatable	UB		
71	Vibratory Plate Compacter	LF-110	110 kg	1	Japan	1996	Operatable	UB		
72	Vibratory Plate Compacter	LF-90	90 kg	1	Japan	1996	Operatable	UB		
73	Vibratory Plate Compacter	LF-90	90 kg	1	Japan	1996	Operatable	UB		
74	Vibratory Plate Compacter	LF-90	90 kg	1	Japan	1996	Operatable	UB		
75	Vibratory Plate Compacter	LF-90	90 kg	1	Japan	1996	Operatable	UB		
76	Compressor	PDS-265-414	30 kg	1	Japan	1996	Operatable	UB		
77	Compressor	PDS-265-414	30 kg	1	Japan	1996	Operatable	UB		
78	Compressor	PDS-265-414	30 kg	1	Japan	1996	Operatable	UB		
79	Compressor	PDS-265-414	30 kg	1	Japan	1996	Operatable	UB		
80	Asphalt sprayer (auto)	FK-615HAL	25-30 l/min	1	Japan	1996	Operatable	UB		
81	Asphalt sprayer (hand)	TES-200	25 l/min	1	Japan	1996	Operatable	UB		
82	Radio communication	FTL-1011/10		1	Japan	1996	Operatable	Arkhangai, Ikh Tamir		
83	Laboratory testing equipments	Complete set		1	Japan	1996	Operatable	Arkhangai, Ikh Tamir		
84	Wheeler for carrying explosives	HZ-J75LP-MR	1 ton	1	Japan	1996	Operatable	UB		



No	Equipment	Model	Specification	Q-ty	Country of manufacture	Produced year	Present condition	Location	Service meter	
									Motor/hour	Km
85	Dump truck	BY-211L.TM	4 ton	1	Japan	1996	Operatable	Arkhangai, Ikh Tamir		
86	Small truck	BY-100LPCB	1.5 ton	1	Japan	1996	Operatable	Arkhangai, Ikh Tamir		126.037
87	Micro bus	TCR-10LRPS		1	Japan	1996	Operatable	UB		
88	Crusher	PGJ-6	90 ton/hour	1	Japan	1996	Operatable	Tuv, Erdene		
89	Crusher	PFJ-4	30 ton/hour	1	Japan	1996	Operatable	Tuv, Erdene		
90	Asphalt plant	NR-600BR	30 ton/hour	1	Japan	1996	Operatable	Tuv, Erdene		
91	Hand guide type vibration roller	LP-650	0.6 ton	1	Japan	1996	Operatable	UB		

**Table-2 EQUIPMENT LIST OF THE “ULAANBAATAR ZAM ZASVAR” COMPANY (State Owned)**

No	Equipment	Model	Specification	Q-ty	Country of manufacture	Year of manufacturing	Present condition	Service meter	
								Motor/hour	Km
1	Dump truck	MNZ 4505	6 ton	1	Russia	1988	Operatable		168349
2	Dump truck	MNZ 4505	6 ton	1	Russia	1988	Operatable		199111
3	Dump truck	MNZ 4505	6 ton	1	Russia	1988	Operatable		195378
4	Dump truck	MNZ 4505	6 ton	1	Russia	1989	Under repair		146557
5	Dump truck	MNZ 554	5 ton	1	Russia	1993	Operatable		125615
6	Dump truck	MNZ 441510	7.5 ton	1	Russia	1995	Under repair		60403
7	Dump truck	MNZ 4503	7.5 ton	1	Russia	1993	Operatable		42079
8	Dump truck	MAZ 5541	9.5 ton	1	Russia	1995	Operatable		36947
9	Dump truck	MAZ 5549	9.5 ton	1	Russia	1989	Operatable		148910
10	Micro bus	UAZ 33206	12 people	1	Russia	1997	Operatable		88034
11	Jeep	UAZ 316126		1	Russia	1995	Operatable		
12	Crane	KS 2561	6.3 ton	1	Russia	1988	Operatable	3860.5	70354
13	Dump truck	EY 415 JDL	15 ton	1	Korea	1995	Operatable		72172
14	Bitumen spreader	DS 395		1	Russia	1996	Operatable		610
15	Truck	GAZ 53		1	Russia	1989	Operatable		38324
16	Motor grader	DZ 122		1	Russia	1988	Operatable	2848	4889
17	Macadam roller	DU 47		1	Russia	1995	Operatable	447	
18	Macadam roller	DU 47		1	Russia	1996	Operatable	408	
19	Macadam roller	DU 47		1	Russia	1994	Operatable	436	
20	Macadam roller	DU 48		1	Russia	1998	Operatable		
21	Compressor	EO 2621		1	Russia	1986	Operatable		
22	Compressor	PR 10		1	Russia	1999	Operatable		
23	Compressor	PR 10		1	Russia	1988	Under repair		
24	Compressor	PR 1018		1	Russia	1982	Under repair		
25	Bulldozer	DZ 42		1	Russia	1988	Scrap		
26	Back hoe	Robex 1300		1	Korea	1995	Operatable		
27	Back hoe	Robex 2000		1	Korea	1995	Operatable		
28	Back hoe	Robex 2800		1	Korea	1999	Operatable		
29	Trailer			1	Russia	1980	Operatable		

No	Equipment	Model	Specification	Q-ty	Country of manufacture	Year of manufacturing	Present condition	Service meter	
								Motor/hour	Km
30	Welding apparatus	SAK		1	Russia	1988	Operatable		
31	Welding apparatus			1	Russia	1988	Operatable		
32	Asphalt cutter			1	Russia	1999	Operatable		
33	Asphalt cutter			1	Russia	1999	Operatable		
34	Air compressor			1	Russia	1988	Operatable		
35	Mobile asphalt drum mixer	DHHB 25		1	China	1999	Operatable		
36	Dump truck	KAMAZ 5511	10 ton	1	Russia	1988	Scrap		226440
37	Dump truck	KAMAZ 5511	10 ton	1	Russia	1988	Scrap		168803
38	Dump truck	KAMAZ 5511	10 ton	1	Russia	1988	Operatable		118651
39	Dump truck	KAMAZ 5511	10 ton	1	Russia	1988	Under repair		215310
40	Dump truck	KAMAZ 5511	10 ton	1	Russia	1988	Under repair		171679
41	Dump truck	KAMAZ 5511	10 ton	1	Russia	1988	Under repair		197702
42	Dump truck	KAMAZ 5511	10 ton	1	Russia	1989	Scrap		176133
43	Dump truck	KAMAZ 5511	10 ton	1	Russia	1989	Under repair		119231
44	Dump truck	KAMAZ 5511	9 ton	1	Russia	1987	Under repair		155311
45	Dump truck	KAMAZ 5511	9 ton	1	Russia	1987	Under repair		155362
46	Truck	ZIL 130	6 ton	1	Russia	1986	Operatable		256150
47	Tanker lorry	ZIL 130	6 ton	1	Russia	1986	Operatable	4113	101257
48	Tanker lorry	TSB 6	6 ton	1	Russia	1988	Scrap		62017
49	Crane	KS 2561	5 ton	1	Russia	1989	Operatable	3537	17816
50	Truck	KRAZ 255		1	Russia	1989	Operatable		109671
51	Motor grader	DZ 122	120 HP	1	Russia	1990	Under repair		5642
52	Tire roller	DU 16	10 ton	1	Russia	1985	Operatable	5436	
53	Dump truck	MAZ 5549	9 ton	1	Russia	1987	Operatable		139139
54	Bus	PAZ 672		1	Russia	1989	Operatable		146172
55	Macadam roller	DU 48	12 ton	1	Russia	1986	Operatable		
56	Semi trailer	ChMZAP	40 ton	1	Russia	1989	Operatable	3061	
57	Truck	GAZ 3307	5 ton	1	Russia	1993	Operatable		74307
58	Asphalt finisher	DS 195		1	Russia	1995	Under repair	559	

**Table-3 EQUIPMENT LIST OF THE ROAD REPAIR AND MAINTENANCE COMPANY "AZZAN" (State owned)**

No.	Equipment	Model	Specification	Q/ty	Country of manufacture	Year of manufacturing	Present condition
1	Truck	ZIL-130	5 ton	1	Russia	1985	Good
2	Truck	GAZ-53	3 ton	1	Russia	1986	Good
3	Water lorry	ZIL-130	6000 L	1	Russia	1999	Good
4	Dump truck	ZIL-555		1	Russia	1986	Fair
5	Dump truck	ZIL-555		1	Russia	1985	Fair
6	Dump truck	ZIL-555		1	Russia	1988	Fair
7	Dump truck	ZIL-5054		1	Russia	1993	Good
8	Dump truck	ZIL-555		1	Russia	1985	Fair
9	Dump truck	KAMAZ-5511		1	Russia	1990	Fair
10	Dump truck	KRAZ-256	12 ton	1	Russia	1988	Fair
11	Bitumen lorry	KAMAZ-53213		1	Russia	1989	Fair
12	Bitumen lorry	KAMAZ-53213		1	Russia	1990	Fair
13	Bitumen lorry	KAMAZ-53213		1	Russia	1990	Fair
14	Bitumen lorry	KAMAZ-53213		1	Russia	1990	Fair
15	Agitator truck	KAMAZ-54112		1	Russia	1989	Fair
16	Agitator truck	KAMAZ-54112		1	Russia	1989	Fair
17	Agitator truck	KAMAZ-54112		1	Russia	1990	Fair
18	Agitator truck	KAMAZ-54112		1	Russia	1990	Fair
19	Truck	ZIL-131		1	Russia	1988	Bad
20	Mobile workshop	GAZ-66		1	Russia	1988	Bad
21	Snow removal machine	ZIL-1314		1	Russia	1990	Good
22	Cement truck	ZIL-130		1	Russia	1990	Fair
23	Truck crane	KE-4561		1	Russia	1984	Fair
24	Dump truck	ZIL-4505		1	Russia	1987	Fair
25	Dump truck	ZIL-4505		1	Russia	1987	Good
26	Dump truck	ZIL-4505		1	Russia	1987	Good
27	Truck crane	KRAZ-256	16 ton	1	Russia	1988	Fair
28	Motor grader	DZ-180		1	Russia	1994	Fair
29	Motor grader	DZ-143		1	Russia	1990	Fair
30	Excavator	JCB		1		1996	Good
31	Excavator	EO-2621		1	Russia	1989	Fair
32	Wheel loader	TO-18		1	Russia	1991	Fair
33	Tractor	UMZ-6	50 HP	1	Russia	1986	Not operatable
34	Asphalt finisher	DS-143	3.5 m	1	Russia	1991	Good
35	Macadam roller	DU-47	5 ton	1	Russia	1990	Fair
36	Macadam roller	DU-47	5 ton	1	Russia	1987	Fair
37	Macadam roller	DU-47	5 ton	1	Russia	1987	Fair
38	Bulldozer	DZ-116	116 HP	1	Russia	1988	Fair
39	Bulldozer	DZ-110	110 HP	1	Russia	1991	Fair
40	Bulldozer	DZ-42		1	Russia	1990	Fair
41	Trailer	4 MZAP		1	Russia	1991	Fair
42	Motor grader	DZ-122	2.8 m	1	Russia	1986	Fair
43	Excavator	EO-2621		1	Russia	1985	Good
44	Bulldozer	D-606		1	Russia	1985	Fair
45	Macadam roller	DU-47	5 ton	1	Russia	1989	Fair
46	Air compressor	PR-10	6 atm.	1	Russia	1986	Fair

No.	Equipment	Model	Specification	Q/ty	Country of manufacture	Year of manufacturing	Present condition
47	Air compressor	PR-10	6 atm.	1	Russia	1990	Fair
48	Air compressor	PKS-5.25		1	Russia	1988	Fair
49	Welding apparatus	SAK		1	Russia	1993	Fair
50	Welding apparatus	SAK-16		1	Russia	1986	Fair
51	Welding apparatus	TD-300		1	Russia	1985	Not operatable
52	Welding apparatus	TD-300		1	Russia	1986	Not operatable
53	Welding apparatus	PSO-300		1	Russia	1987	Not operatable
54	Welding apparatus	TDM-401		1	Russia	1992	Good
55	Welding apparatus	TDM-401		1	Russia	1990	Good
56	Welding apparatus	TDM-401		1	Russia	1990	Fair
57	Welding apparatus	BB-400		1	Russia	1992	Good
58	Drilling machine	211-1353		1	Russia	1990	Good
59	Drilling machine	2M-112		1	Russia	1989	Fair
60	Grindstone			1	Russia	1985	Fair
61	Vibration roller			1	Russia	1993	Good
62	Steamer	E-01		1	Russia	1989	Good
63	Steamer	E-01		1	Russia	1996	Good
64	Asphalt mixer	DE-117		1	Russia	1988	Fair
65	Asphalt mixer	DE-117		1	Russia	1987	Fair
66	Asphalt mixer	D-508		1	Russia	1985	Not operatable
67	Concrete mixer	SB-75		1	Russia	1987	Good
68	Clay mixer			1	Russia	1989	Not operatable
69	Crusher	CM-561		1	Russia	1987	Not operatable
70	Compactor			1	Great Britain	1997	Good
71	Compactor			1	Great Britain	1997	Good
72	Bitumen sprayer			1	Great Britain	1997	Good
73	Cutter			1	China	1999	Good

**Table-4 EQUIPMENT LIST OF THE “BAT ZAM” COMPANY (Private)**

No.	Equipment	Model	Specification	Q/ty	Country of manufacture	Year of manufacturing	Present condition
1	Dump truck	ZIL-4505	5 ton	5	Russia	1990	Good
2	Truck	GAZ-53	3 ton	1	Russia	1990	Good
3	Water lorry	KO-002	6000 L	1	Russia	1989	Fair
4	Bulldozer	DZ-110	110 HP	1	Russia	1987	Under repair
5	Macadam roller	DU-47	5 ton	1	Russia	1987	Fair
6	Macadam roller	DU-48	10 ton	1	Russia	1990	Good
7	Excavator	EO-3322	0.65 m <sup>3</sup>	1	Russia	1991	Good
8	Motor grader	DZ-122	2.8 m	1	Russia	1990	Fair
9	Asphalt finisher	DS-126	3.5 m	1	Russia	1985	Under repair
10	Tractor	UMZ-6	50 HP	1	Russia	1986	Fair
11	Dump truck trailer with 1 beam		5 ton	5	Russia	1986	Fair
12	Truck trailer with 2 beam		3 ton	1	Russia	1991	Fair
13	Welding apparatus		380 V	2	Russia	1997	Good
14	Mechanical tackle		2 ton	1	Russia	1993	Good
15	Vice			1	Russia	1990	Fair
16	Grindstone			1	Russia	1993	Good
17	Saw, plane			1	Russia	1997	Good
18	Welding apparatus	SAK		1	Russia	1997	Fair
19	Air compressor	PR-10	6 atm	1	Russia	1993	Good
20	Level			1	Russia	1998	Good
21	Theodolite			1	Russia	1994	Good
22	Tank for bitumen			1	Russia	1996	Good
23	Square vibrator			1	Russia	1992	Fair
24	Deep vibrator			1	Russia	1992	Fair
25	Form for border			3	Russia	1995	Good
26	Hand roller			1	Russia	1994	Good
27	Asphalt cutter			1	Russia	1996	Good

**Table-5 EQUIPMENT LIST OF THE “ASBI” COMPANY (Private)**

No.	Equipment	Model	Specification	Q/ty	Country of manufacture	Year of manufacturing	Present condition
1	Bulldozer	T 130	22 ton	1	Russia	1985	Good
2	Motor grader	DZ-122A	180 HP	1	Russia	1990	Good
		DZ 57		1	Russia	1994	Good
3	Back hoe	EO-3322	0.5 m <sup>3</sup>	2	Russia	1991	Good
		EO-2621	0.65 m <sup>3</sup>	1	Russia	1989	Good
4	Macadam roller	DU-47	5 ton	1	Russia	1987	Good
		DU-48	8 ton	1	China	1988	Good
5	Tire roller	ZL-14	14 ton	1	Russia	2000	Good
6	Concrete mixer	SB-92	4 m <sup>3</sup>	1	Russia	1993	Good
7	Crane	KS-4561	16 ton	1	Russia	1989	Good
		KS-2561	5 ton	1	Russia	1992	Good
8	Scraper	DZ-357	8 m <sup>3</sup>	2	Russia	1988	Fair
9	Dump truck	ZIL 555	5 ton	10	Russia	1987-1996	Good
10	Semi trailer		40 ton	1	Russia	1988	Fair
			20 ton	1	Russia	1988	Fair
11	Water lorry		5 ton	2	Russia	1994	Good
12	Compressor	PR 10	110 HP	1	Russia	1995	Good
13	Tractor	MTZ 50	50 HP	1	Russia	1990	Good
14	Truck	GAZ 53	4 ton	1	Russia	1987	Good
		ZIL 130	6 ton	1	Russia	1987	Good
15	Car	UAZ 469	7people	1	Russia	1998	Good
		BENZ		1	Germany	1998	Good
16	Microbus	UAZ 452	12 people 1 ton	1	Russia	1998	Good
17	Asphalt sprayer		5 ton	2	Russia	1992	Good
18	Asphalt finisher	DS 126	8m <sup>3</sup>	2	Russia	1985	Good
19	Portable welding	SAK		2	Russia	1997	Good
20	Fuel lorry		8 ton	1	Russia	1996	Good
21	Concrete cutter		30 cm	1	Russia	1995	Good
22	Compactor (hand)		40 x 40	1	Russia	1996	Good
23	Accommodation			2	Russia	1995	Good
24	Total station	SET 6		1	Japan	1996	Good
25	Level	NI 2		1	Germany	1997	Good
26	Nuclear densometer			1	USA	1999	Good
27	Sand cone			1	Germany	1999	Good
	TOTAL			50			

**Table-6 EQUIPMENT LIST OF THE “HUCHIT ZAM” COMPANY (Private)**

No.	Equipment	Model	Specificaiton	Q/ty	Country of manufacture	Year of manufacturing	Present condition
1	Dump truck	ZIL-4505	5 ton	1	Russia	1990	Fair
2	Dump truck	ZIL-4505	5 ton	1	Russia	1993	Good
3	Dump truck	ZIL-4505	5 ton	1	Russia	1987	Fair
4	Dump truck	KRAZ-256	12 ton	1	Russia	1978	Fair
5	Dump truck	KRAZ-256	12 ton	1	Russia	1989	Fair
6	Dump truck	KRAZ-256	12 ton	1	Russia	1976	Fair
7	Truck	ZIL-130	5 ton	1	Russia	1979	Fair
8	Water lorry	ZIL-130	6 ton	1	Russia	1988	Fair
9	Truck crane KRAZ	KS-4561	16 ton	1	Russia	1982	Fair
10	Scraper	MOAZ D-357	15 ton	1	Russia	1988	Good
11	Scraper	MOAZ D-357	15 ton	1	Russia	1989	Fair
12	Scraper	MOAZ D-357	15 ton	1	Russia	1985	Fair
13	Scraper	MOAZ D-357	15 ton	1	Russia	1988	Fair
14	Motor grader	D-557	2.8 m	1	Russia	1989	Fair
15	Motor grader	D-557	2.8 m	1	Russia	1986	Fair
16	Tractor	MTZ-510	65 HP	1	Russia	1992	Fair
17	Tire Roller	DU-16	25 ton	1	Russia	1987	Good
18	Macadam roller	DU-47	5 ton	1	Russia	1990	Fair
19	Macadam roller	DU-48	10 ton	1	Russia	1989	Fair
20	Bulldozer	T-130	22 ton	1	Russia	1990	Fair
21	Excavator	EO-3322	0.65 m <sup>3</sup>	1	Russia	1988	Fair
22	Asphalt finisher	DS-126	3.5 m	1	Russia	1987	Fair
23	Air compressor	PR-10	6 atm	1	Russia	-	Fair
24	Welding apparatus	SAK		1	Russia	-	Good
25	Hand roller			1	Russia	-	Fair
26	Electric generator	NSh-60	380 V	1	Russia	-	Fair
27	Electric generator	UD-25	220 V	1	Russia	-	Good
28	Water pump	WB-20x	1 ton/min	1	Russia	-	Good
29	Welding apparatus			1	Russia	-	Good



**Table-7 EQUIPMENT LIST OF THE “GAN GUUR” COMPANY (Private)**

No.	Equipment	Model	Specification	Q-ty	Country of manufacture	Year of manufacturing	Present condition
1	Vehicles	ZIL-130	5 ton	3	Russia	1988-1999	1 under repair
2		ZIL-555	4.5 ton	3	Russia	1988-1999	1 under repair
3		ZIL-4121	5.5 ton	4	Russia	1992-1998	Operatable
4		KRAZ-256	12 ton	2	Russia	1989-1999	Operatable
5	Water lorry	ZIL-130	5 ton	1	Russia	1988	Operatable
6	Truck Crane	KS-5363	25 ton	1	Russia	1995	Operatable
7		KS-4560	16 ton	1	Russia	1989	Operatable
8		KRAZ-256	16 ton	2	Russia	1988-1999	Operatable
9	Excavator	EO-5111	1 m <sup>3</sup>	1	Russia	1992	Operatable
10		EO-3322	0.65	1	Russia	1988	Operatable
11	Roller	DU-16	10 ton	1	Russia	1989	Operatable
12		DU-45	5 ton	1	Russia	1999	Operatable
13		DU-5	2 ton	1	Russia	1995	Operatable
14	Bulldozer	DZ-130	100 HP	1	Russia	1994	Operatable
15	Agitator truck	KAMAZ-5555	4 m <sup>3</sup>	1	Russia	1989	Operatable
16	Electric generator	JES-60	60 kW	3	Russia	1989-1998	Operatable
17		JES-30	30 kW	1	Russia	1995	Operatable
18	Concrete mixer	SM-10	0.33 m <sup>3</sup>	1	Russia	1989	Operatable
19		SM-5	0.15 m <sup>3</sup>	1	Russia	1989	Operatable
20	Reinforcing bar cutter	SMJ-270	40 mm	3	Russia	1989-1997	Operatable
21	Reinforcing bar bender	SMJ-310	40 mm	2	Russia	1988-1996	Operatable
22	Water pump	S-245	120 m <sup>3</sup> /h	5	Russia	1988-1995	Operatable
23	Diesel breaker	S-2300	5 ton	1	Russia	1989	Operatable
24	Deep vibrator	IM-16	50m <sup>3</sup>	5	Russia	1989-1997	Operatable
25	Square vibrator	IM-47	1 m <sup>2</sup>	2	Russia	1988	Operatable
26	Trailer	M-20	20 ton	1	Russia	1999	Operatable
27	1 and 2 beam truck trailers	ZIL-130 ZIL-555	5 ton	4	Russia	1988-1994	Operatable

**Table-8 EQUIPMENT LIST OF THE “TECHNO-ARCH’ COMPANY (Private)**

No.	Equipment	Model	Specification	Q-ty	Country of manufacture	Year of manufacturing	Present condition
1	Crane	KS-4361	16 ton	1	Russia	1988	Operatable
2	Dump truck	ZIL-4505	5 ton	1	Russia	1989	Operatable
3	Concrete mixer	SB-16	330 L	1	Russia	1991	Operatable
4	Concrete mixer	S-80	167 L	1	Russia	1992	Operatable
5	Reinforcing bar bender	S-1465	40 mm	1	Russia	1989	Operatable
6	Reinforcing bar cutter	S-333	40 mm	1	Russia	1986	Operatable
7	Welding apparatus	TD-500	400 A	1	Russia	1989	Operatable
8	Square vibrator	UB-112	36 V	1	Russia	1989	Operatable
9	Deep vibrator	UB-47	36 V	2	Russia	1989	Operatable
10	Air compressor	ZIP-54	7 atm	1	Russia	1986	Operatable
11	Motor pump	MG-40 G	63 ton	1	Russia	1990	Operatable
12	Air receiver	R-10	10 m <sup>3</sup>	1	Russia	1992	Operatable
13	Bulk cement storage	ZTA-100	400 ton	4	Russia	1995	Operatable
14	Electric substation	TP10/04	250 kVA	1	Russia	1992	Operatable
15	Diesel station	ADS-30	37.5 kW	1	Russia	1989	Operatable
16	Winch	TL-3	3 ton	1	Russia	1992	Operatable
17	Lathe machine	ZB-631	360 mm	1	Russia	1993	Operatable
18	Drilling machine	2B-132	19 mm	1	Russia	1986	Operatable
19	Lathe machine	Titan	250 mm	1	Russia	1980	Operatable
20	Guillotine cutter	N-3314	1600 mm	1	Russia	1989	Operatable
21	Level	NV-3	-	1	Russia	1992	Operatable
22	Theodolite	2T-5	-	1	Russia	1989	Operatable
23	Form for big border	-	2x20 pcs	2	Russia	1995	Operatable
24	Form for small border	-	1x40 pcs	1	Russia	1993	Operatable
25	Form for pipe	-	D-1 m	2	Russia	1991	Operatable
26	Form for beam	-	L-15 m	1	Russia	1988	Operatable
27	ZIIT-5 form	-	2 x 2 S	2	Russia	1989	Operatable

**Table-9 EQUIPMENT LIST OF THE EQUIPMENT LEASING “TTTurees”  
COMPANY (State owned)**

No.	Equipment	Model	Specification	Q/ty	Country of manufacture	Year of manufacturing	Present condition
1	Motor grader Komatsu	GD-611	2.8 m	1	Japan	1999	Operatable
2	Motor grader Komatsu	GD-611	2.8 m	1	Japan	1999	Operatable
3	Motor grader Komatsu	GD-611	2.8 m	1	Japan	1999	Operatable
4	Wheel Loader Komatsu	WA-180	1.4 m <sup>3</sup>	1	Japan	1999	Operatable
5	Wheel Loader Komatsu	WA-180	1.4 m <sup>3</sup>	1	Japan	1999	Operatable
6	Excavator Komatsu	PW-150	1 m <sup>3</sup>	1	Japan	1999	Operatable
7	Tire Roller Dynapac	CP-221	12.5 ton 21 ton with ballast	1	Sweden	1999	Operatable
8	Tire Roller Dynapac	CP-221	12.5 ton 21 ton with ballast	1	Sweden	1999	Operatable
9	Tire Roller Dynapac	CP-221	12.5 ton 21 ton with ballast	1	Sweden	1999	Operatable
10	Water lorry with sprayer, broom and cutter	ZIL-130 MDK-433360	6,000 L	1	Russia	1998	Operatable
11	Water lorry with sprayer, broom and cutter	ZIL-130 MDK-433360	6,000 L	1	Russia	1998	Operatable
12	Water lorry with sprayer, broom and cutter	ZIL-130 MDK-433360	6,000 L	1	Russia	1998	Operatable
13	Water lorry with sprayer, broom and cutter	ZIL-130 MDK-433360	6,000 L	1	Russia	1998	Operatable
14	Water lorry with sprayer, broom and cutter	ZIL-130 MDK-433360	6,000 L	1	Russia	1998	Operatable