

表一C 現橋一般圖 (No.2) General View Of Existing New Market South Bridge

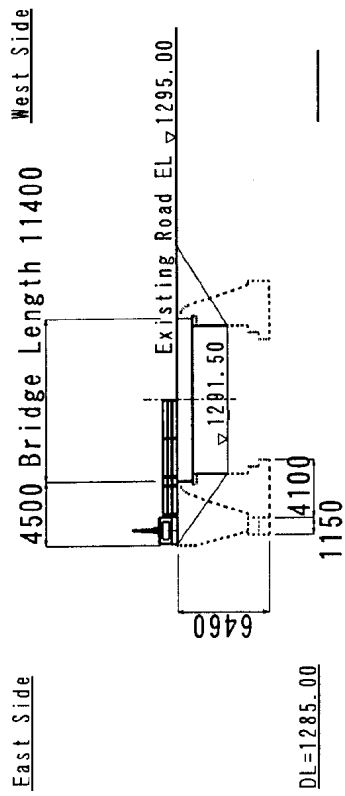

Cross Section
S=1/200

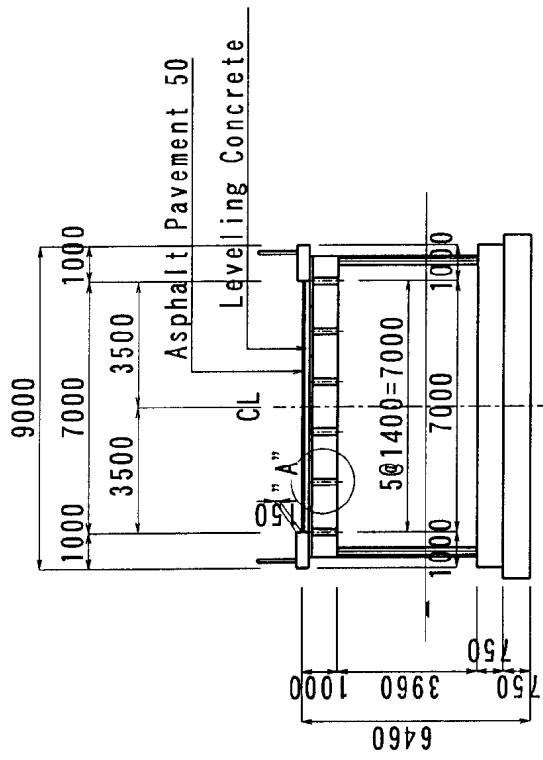
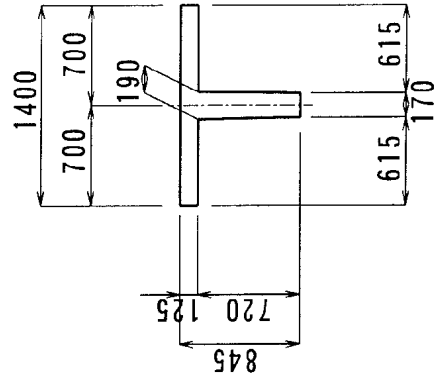

Detail "A"
S=1/50

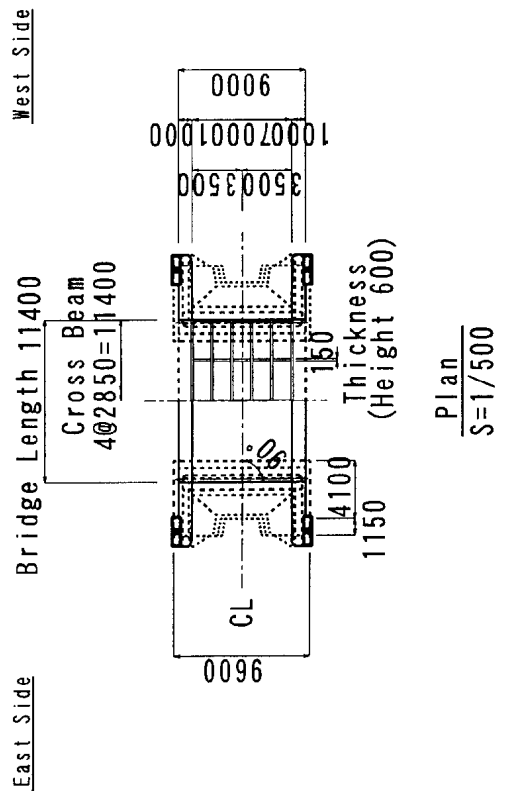

A: GENERAL VIEW OF WESTERN RAILWAY CROSSING (F/0)

H=1:2000
 PROFILE Scale V=1:400

Railway
 1-Main Line & 5-Branch Lines

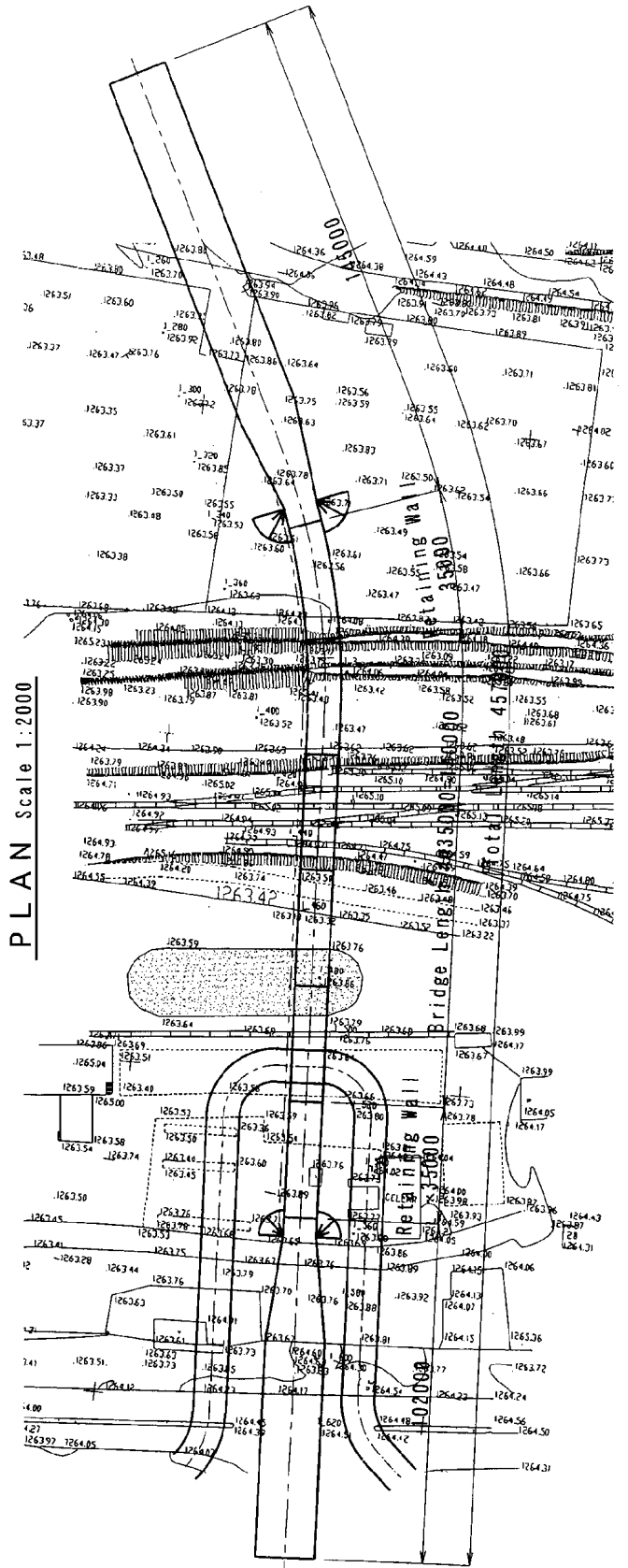
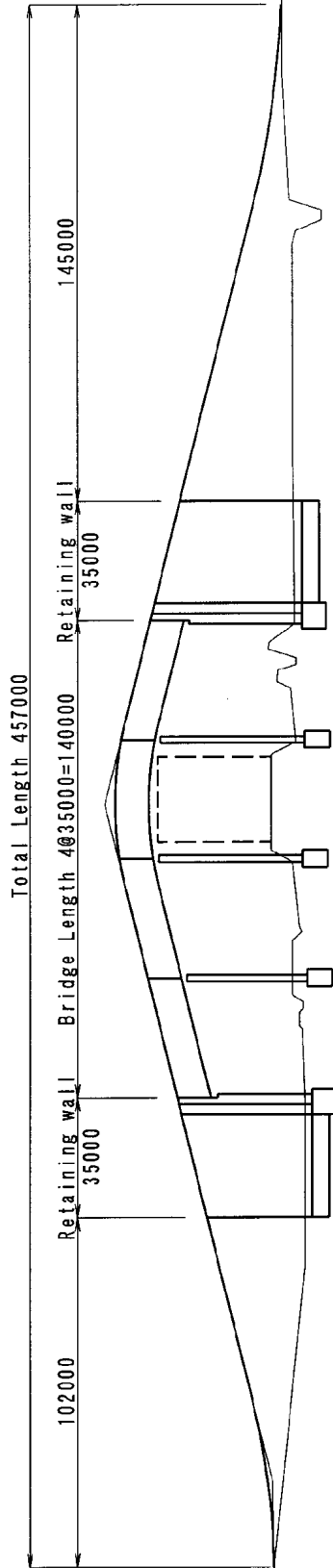

A : SECTION OF WESTERN RAILWAY CROSSING (F/0)

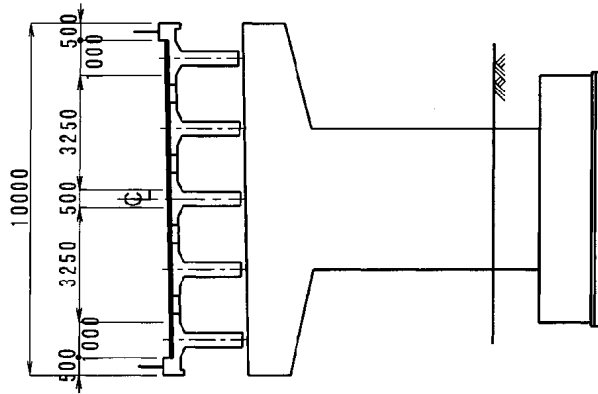

Bridge Section

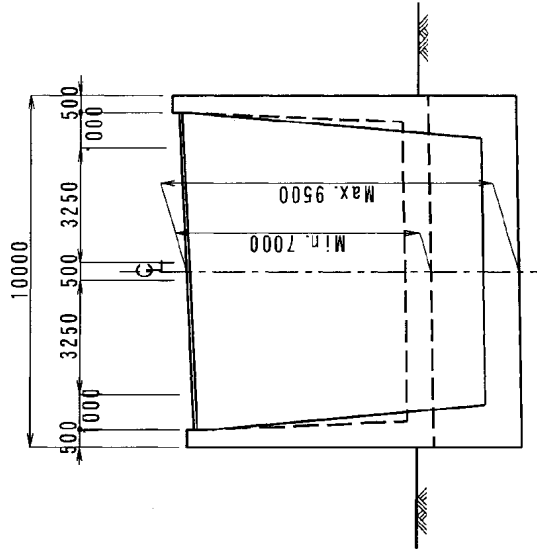

Retaining Wall Section

A' : GENERAL VIEW OF WESTERN RAILWAY CROSSING (U/P)

H=1:2000
 Scale V=1:400
PROFILE
 Railway
 1-Main Line & 5-Branch Lines

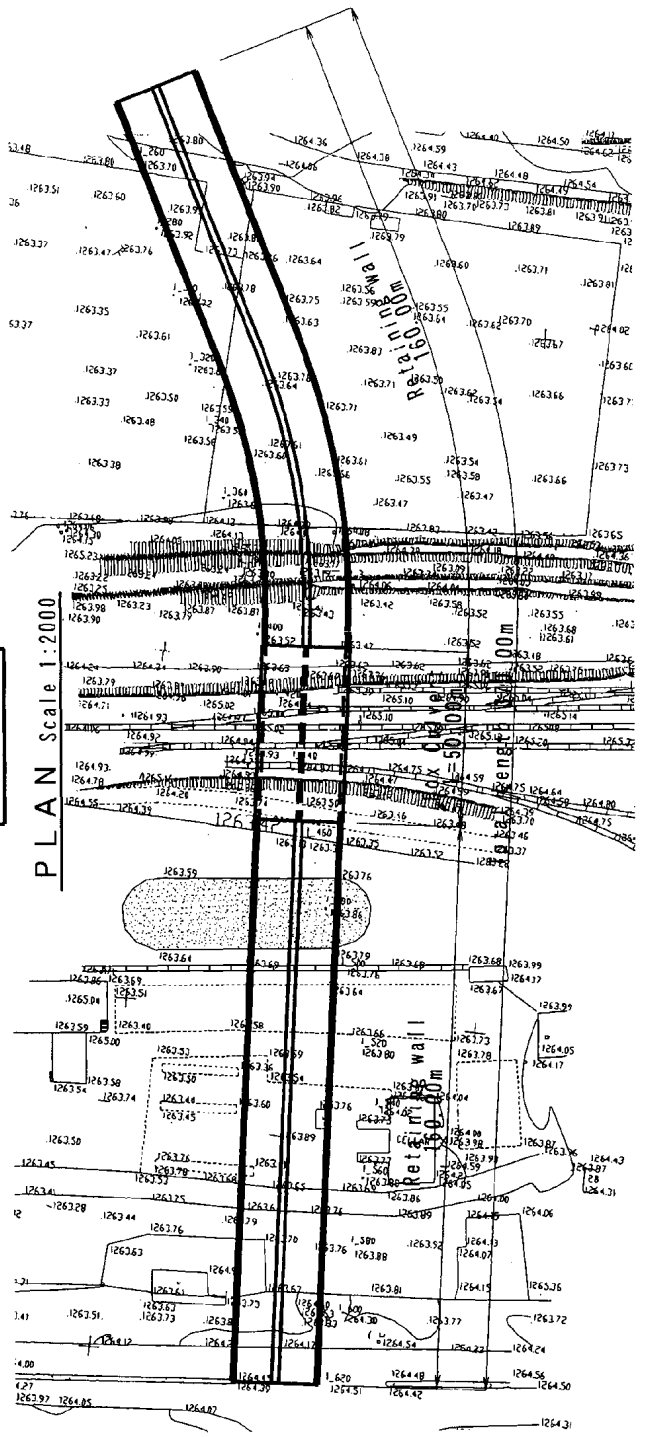
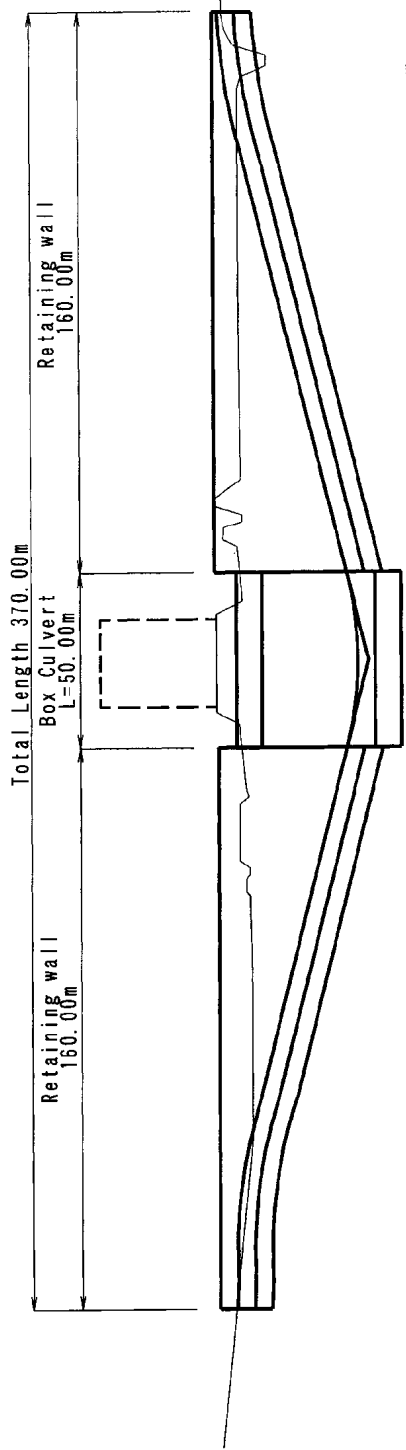

A' : SECTION OF WESTERN RAILWAY CROSSING (U/P)

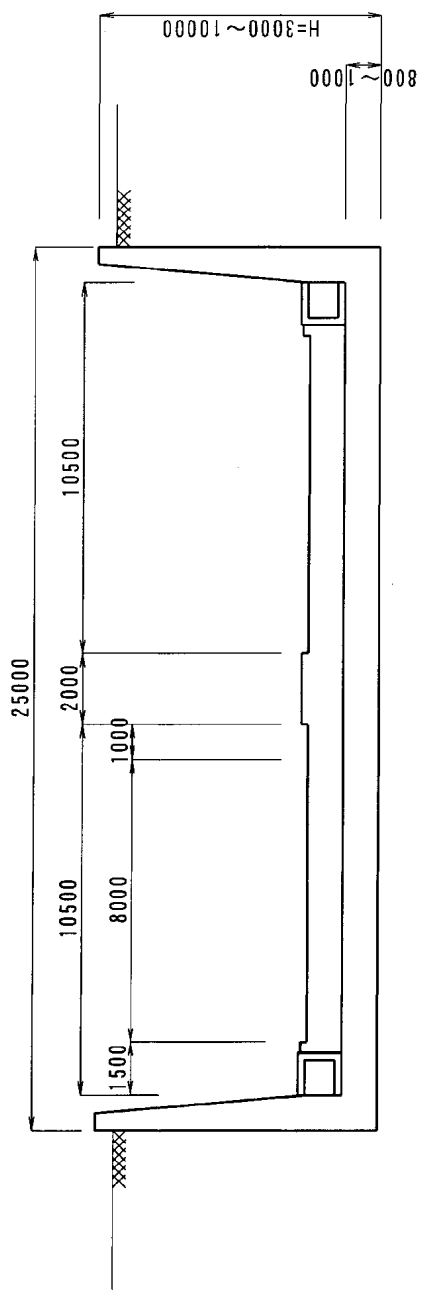

U-Shape Retaining Wall Section

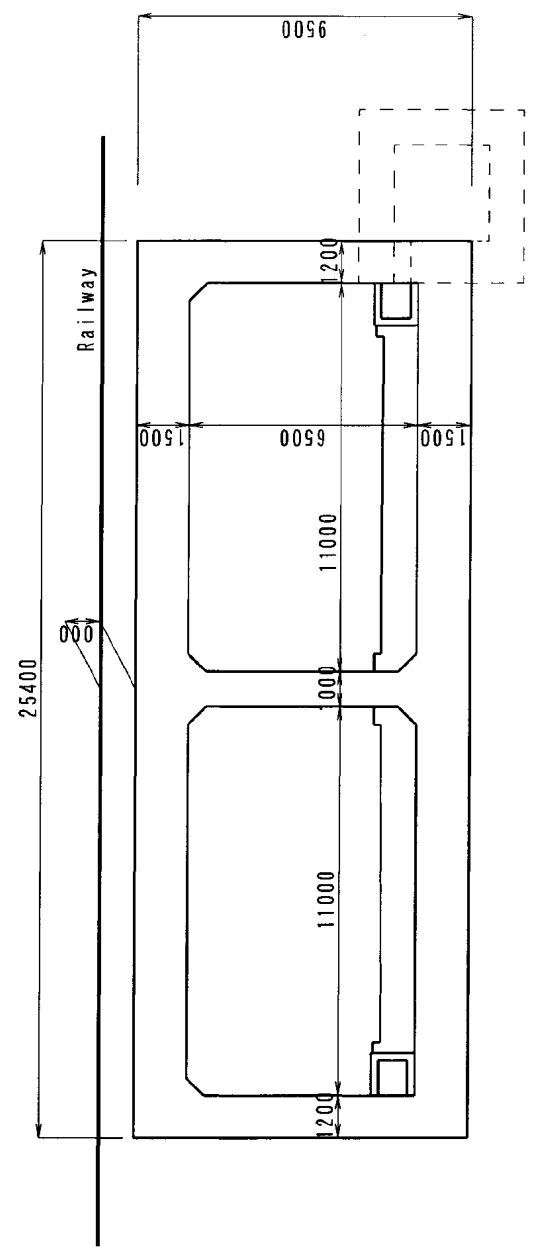

Box Culvert Section

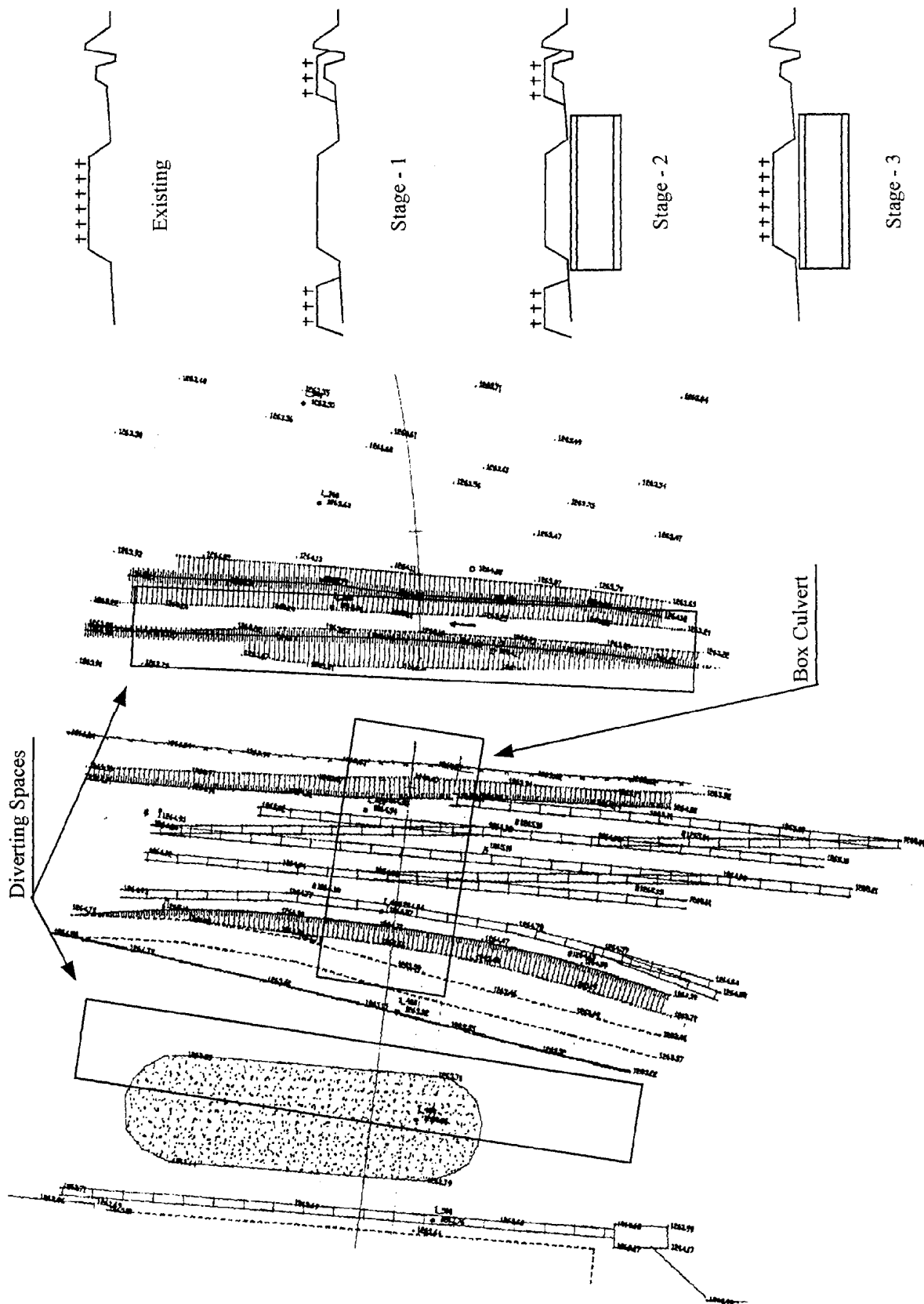

Staging Plan for Underpass Structure

B : GENERAL VIEW OF EAST CROSS (F/0)

PROFILE H=1:3000
Scale V=1:400

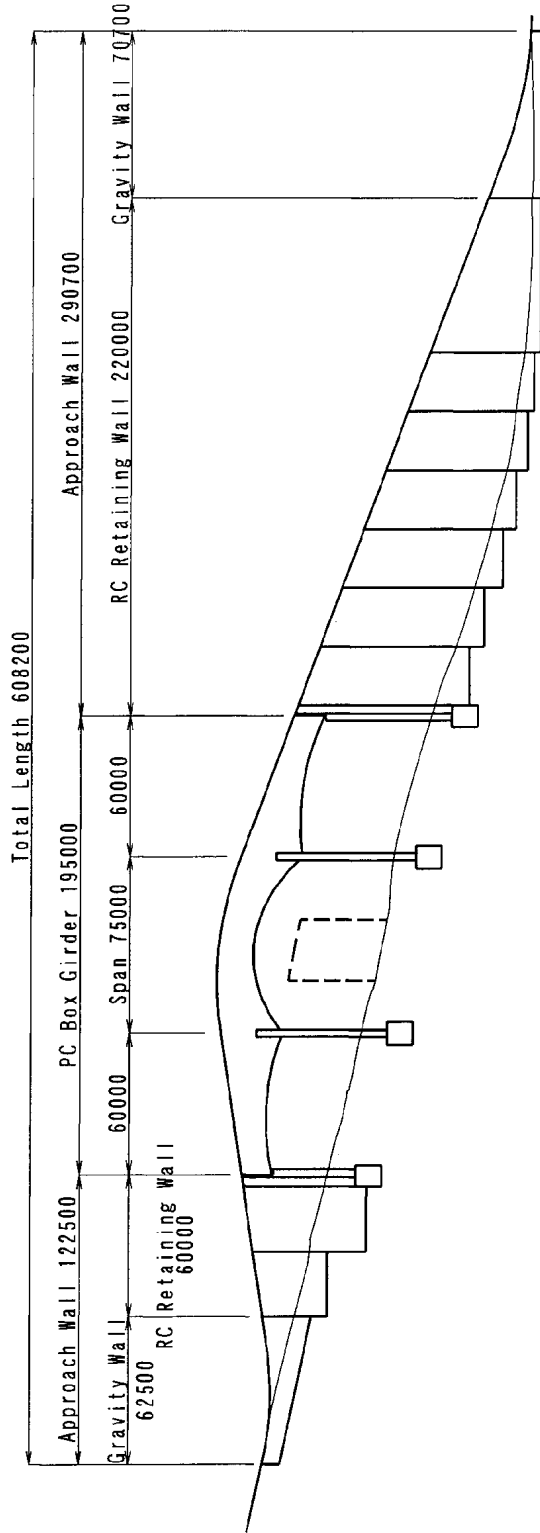

PLAN Scale 1:3000

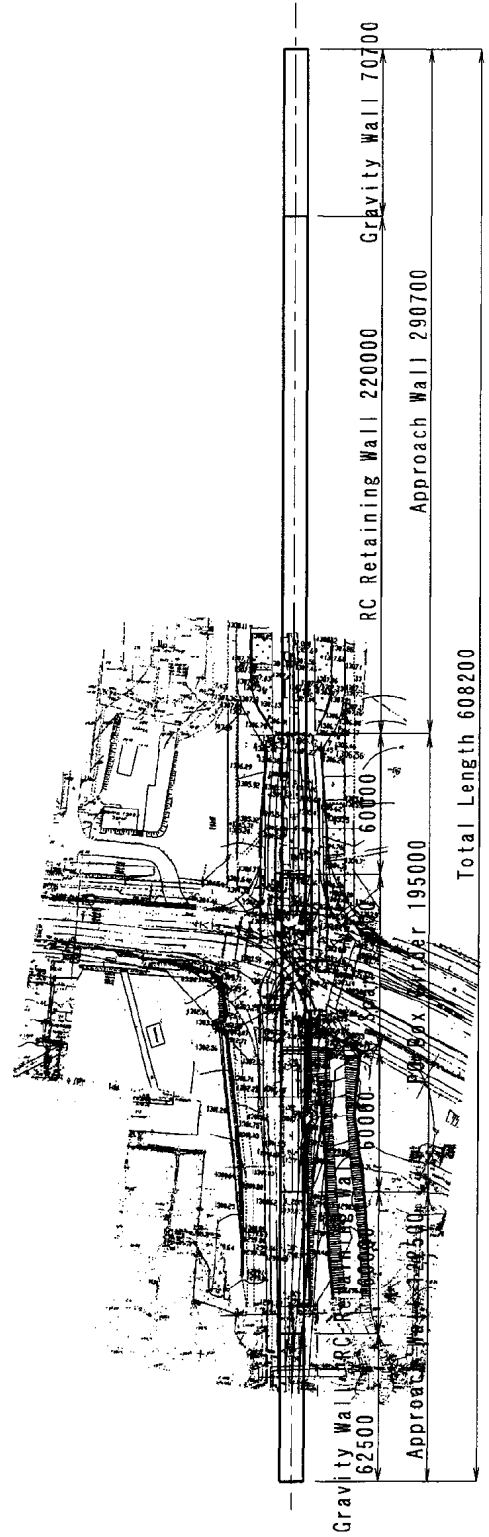

B: SECTION OF EAST CROSS (F/0)

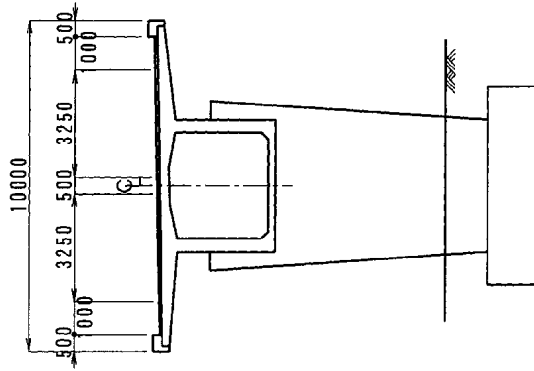

Bridge Section

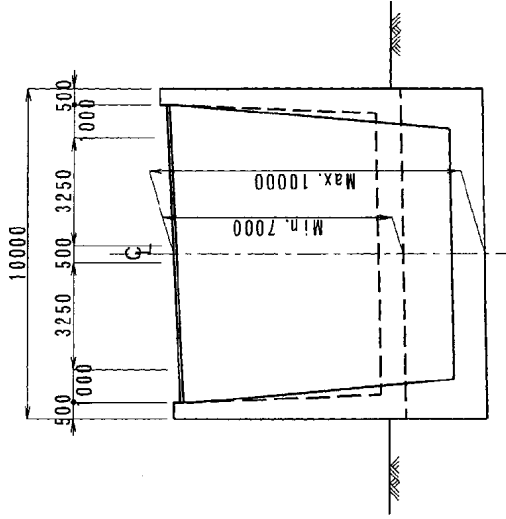

Retaining Wall Section

C: GENERAL VIEW OF WEST CROSS (F/0)

H=1:2000
SCALE V=1:400

PROFILE

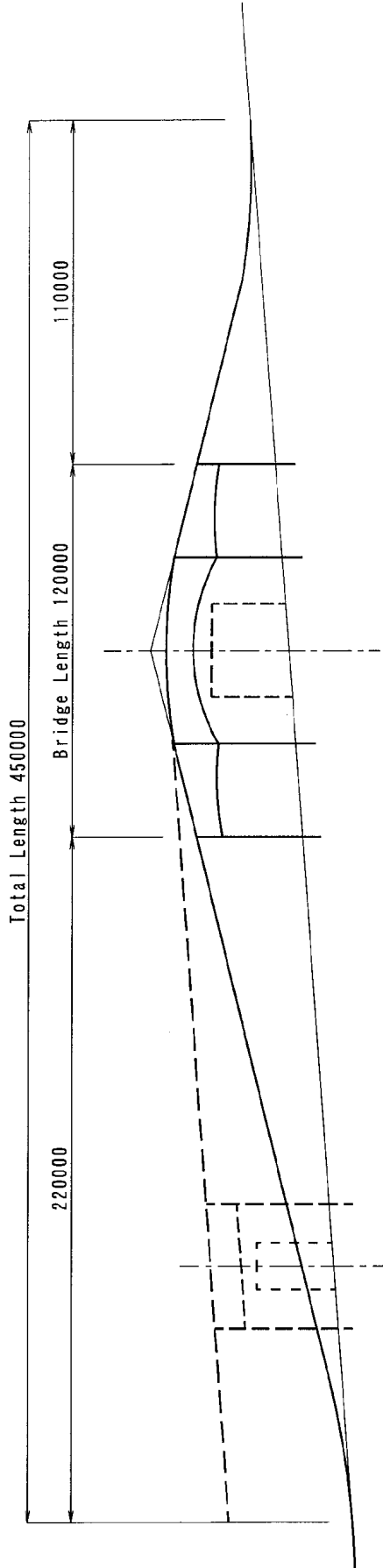

PLAN Scale 1:5000

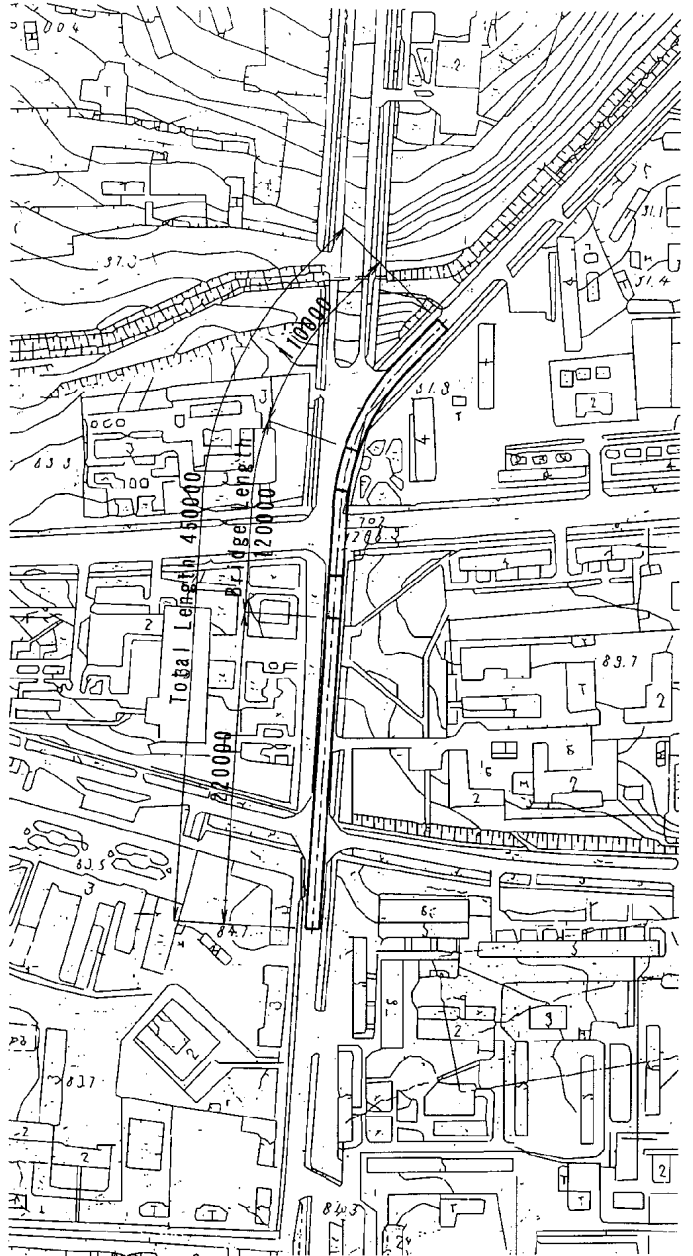

D : GENERAL VIEW OF WEST TEEVERCHID (F/0)

PROFILE H=1:2000
Scale V=1:400

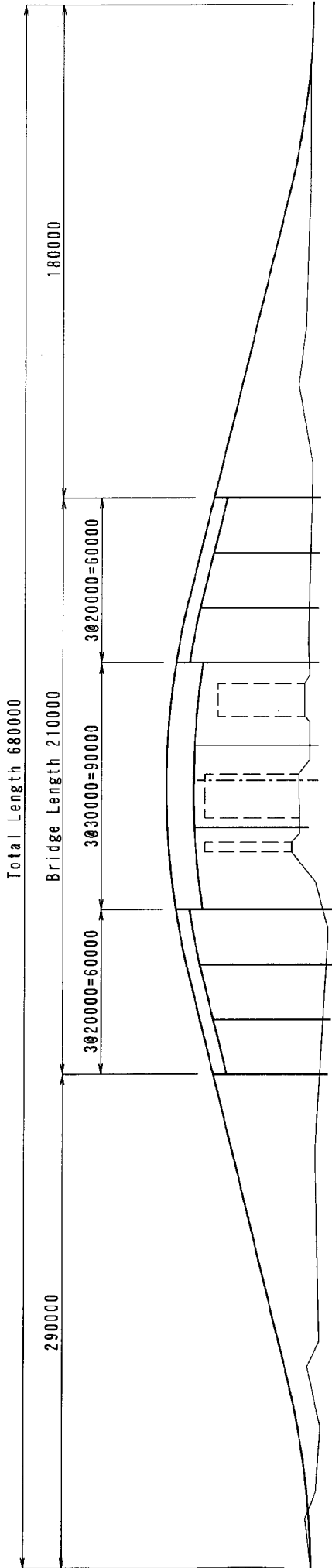

PLAN Scale 1:5000

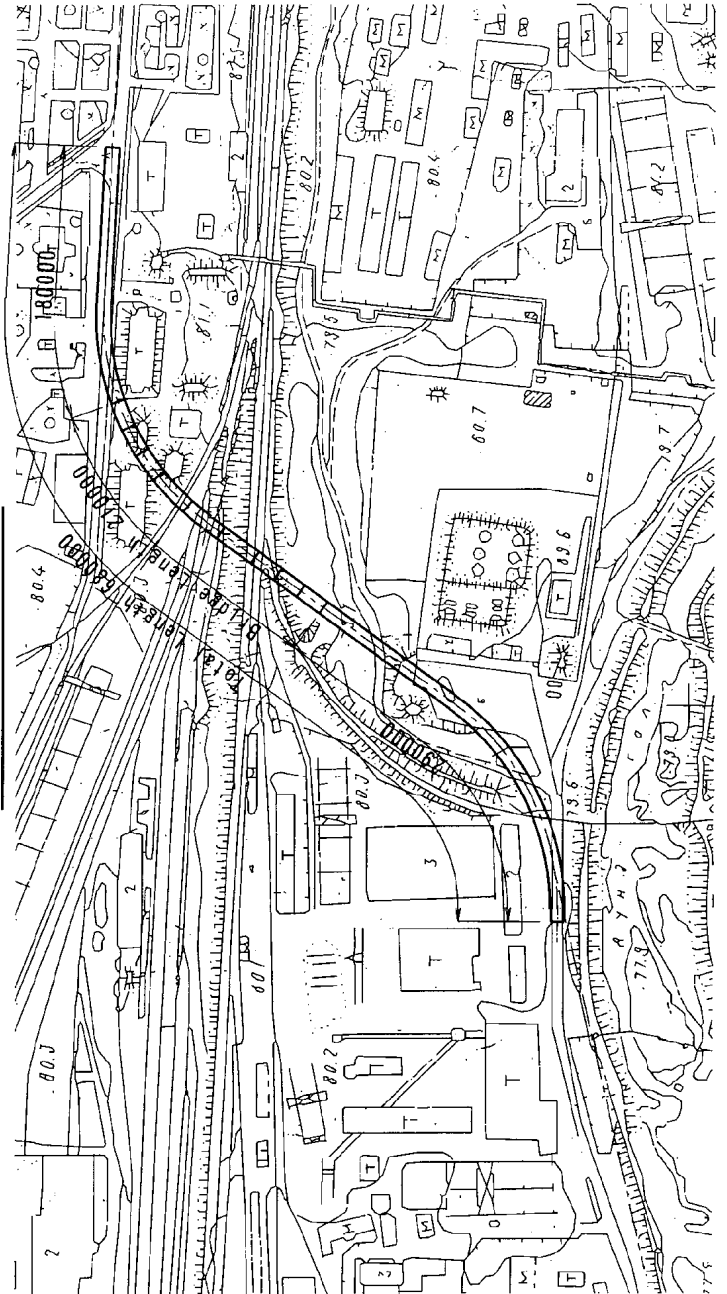

E : GENERAL VIEW OF NEW CENTRAL MARKET (F/0)

PROFILE
 H=1:2000
 Scale V=1:400

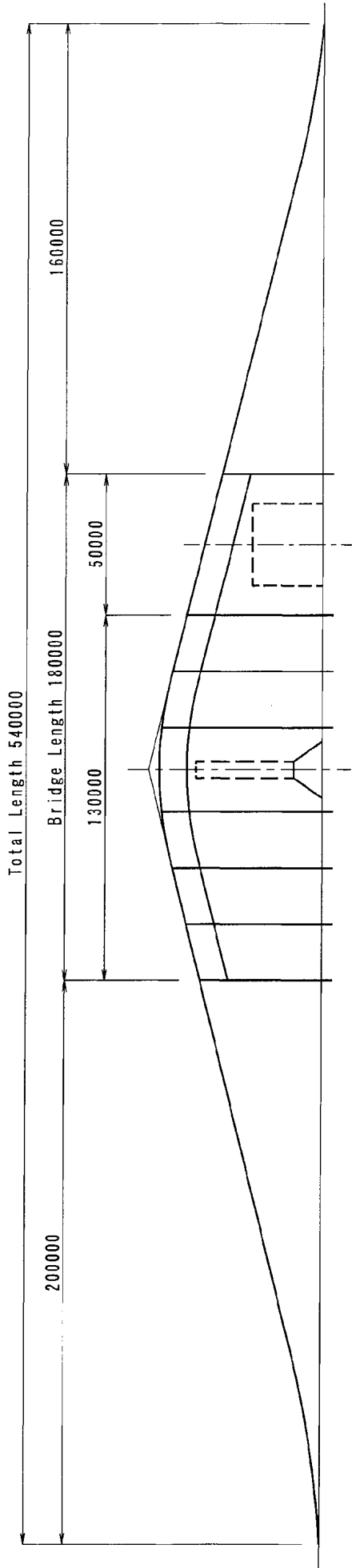

PLAN Scale 1:5000

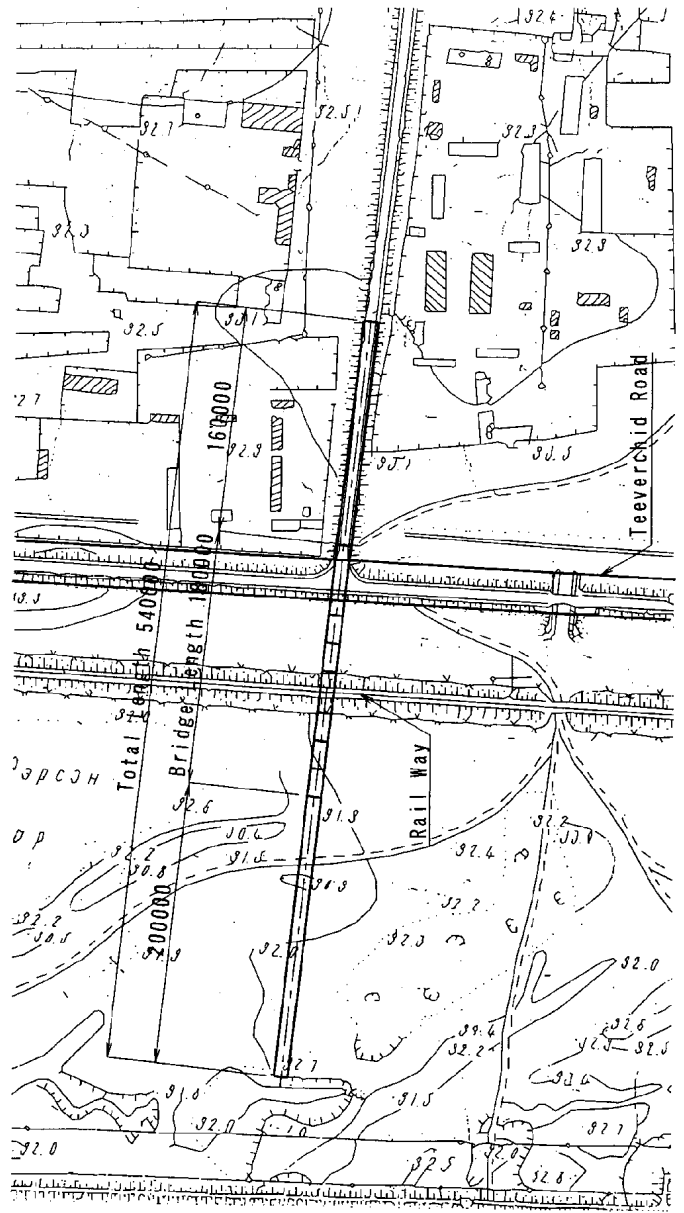

添付資料 5 - 6 機材リスト

表-1 ロックアスファルト舗装道路建設計画の機材

EQUIPMENT LIST OF THE "ERDENE ZAM" COMPANY (State)

| No | Equipment | Model | Specification | Q/ty | Country of origin | Produced year | Present condition | Location | Service meter | |
|----|-------------------|-----------|------------------------|------|-------------------|---------------|-------------------|----------------------|---------------|-------|
| | | | | | | | | | Motor/hour | km |
| 1 | Excavator | CAT-330 | 1.4m ³ | 1 | USA | 1996 | Operable | Sharin-Gol | | |
| 2 | Excavator | CAT-320 | 0.65m ³ No1 | 1 | USA | 1996 | Operable | Arkhangai, Ikh Tamir | 4.442 | |
| 3 | Excavator | CAT-320 | 0.65m ³ No2 | 1 | USA | 1996 | Operable | Khutel | | |
| 4 | Excavator | CAT-320 | 0.65m ³ No3 | 1 | USA | 1996 | Operable | UB | | |
| 5 | Excavator | CAT-320 | 0.65m ³ No4 | 1 | USA | 1996 | Operable | Arkhangai, Ikh Tamir | | |
| 6 | Excavator | CAT-320 | 0.65m ³ No5 | 1 | USA | 1996 | Operable | Arkhangai, Ikh Tamir | 2.712 | |
| 7 | Excavator | CAT-320 | 0.65m ³ No6 | 1 | USA | 1996 | Operable | Sharin-Gol | | |
| 8 | Tractor shovel | CAT-938F | 2.1m ³ No1 | 1 | USA | 1996 | Operable | UB-Baga Nuur | | |
| 9 | Tractor shovel | CAT-938F | 2.1m ³ No2 | 1 | USA | 1996 | Operable | Arkhangai, Ikh Tamir | | |
| 10 | Tractor shovel | CAT-910F | 1.2m ³ No1 | 1 | USA | 1996 | Operable | UB | | |
| 11 | Tractor shovel | CAT-910F | 1.2m ³ No2 | 1 | USA | 1996 | Operable | Arkhangai, Ikh Tamir | 4.132 | |
| 12 | Crawler-Drill | HCR-9DS | Hydraulic 180 kg | 1 | Japan | 1996 | Operable | UB | 330 | |
| 13 | Hydraulic Breaker | H10XB | Hydraulic 130 kg | 1 | Japan | 1996 | Operable | UB | | |
| 14 | Vibration-Roller | CA-251STD | 10 ton | 1 | Japan | 1996 | Operable | Arkhangai, Ikh Tamir | 3.840 | |
| 15 | Tire-Roller | CP-201 | 10 ton (No1) | 1 | Japan | 1996 | Operable | UB | 2.160 | |
| 16 | Tire-Roller | CP-201 | 10 ton (No2) | 1 | Japan | 1996 | Operable | UB | 2.460 | 9.404 |
| 17 | Macadam Roller | CS-12 | 10 ton (No1) | 1 | Japan | 1996 | Operable | UB | 2.239 | |
| 18 | Macadam Roller | CS-12 | 10 ton (No2) | 1 | Japan | 1996 | Under repair | UB | | |
| 19 | Bulldozer | D-155A | 32 ton | 1 | Japan | 1996 | Operable | Sharin Gol | | |
| 20 | Bulldozer | D-85A21 | 21 ton No1 | 1 | Japan | 1996 | Operable | Sharin Gol | | |
| 21 | Bulldozer | D-85A21 | 21 ton No2 | 1 | Japan | 1996 | Operable | Arkhangai, Ikh Tamir | 4.229 | |
| 22 | Bulldozer | D-6555E12 | 15 ton | 1 | Japan | 1996 | Operable | UB | | |

| No | Equipment | Model | Specification | Q/ty | Country of origin | Produced year | Present condition | Location | Service meter | |
|----|------------------|-----------|---------------|------|-------------------|---------------|-------------------|----------------------|---------------|---------|
| | | | | | | | | | Motor/hour | km |
| 23 | Motor-Grader | GD-511AI | 3.7 m No 1 | 1 | Japan | 1996 | Operable | Arkhangai, Ikh Tamir | 5.076 | |
| 24 | Motor-Grader | GD-511AI | 3.7 m No 2 | 1 | Japan | 1996 | Under repair | UB | | |
| 25 | Asphalt-finisher | NF-130VDM | 2.5-4.5 m | 1 | Japan | 1996 | Operable | UB | | |
| 26 | Water-lorry | FF-3HJSA | 6000 l No1 | 1 | Japan | 1996 | Operable | UB | | 60.000 |
| 27 | Water-lorry | FF-3HJSA | 6000 l No2 | 1 | Japan | 1996 | Operable | Arkhangai, Ikh Tamir | | 68.810 |
| 28 | Fuel-lorry | FF-3HJSA | 6000 l No1 | 1 | Japan | 1996 | Operable | Arkhangai, Ikh Tamir | | 53.368 |
| 29 | Fuel-lorry | FF-3HJSA | 6000 l No2 | 1 | Japan | 1996 | Operable | UB | | 56.546 |
| 30 | Crane | FH-224SA | 8 ton | 1 | Japan | 1996 | Operable | Arkhangai, Ikh Tamir | | |
| 31 | Crane | TL-250E | 25 ton | 1 | Japan | 1996 | Operable | Arkhangai, Ikh Tamir | 2.369 | 18.931 |
| 32 | Trailer | SS-633 | 30 ton | 1 | Japan | 1996 | Operable | UB | | 70.178 |
| 33 | Mobile work-shop | HZ-227SA | No1 | 1 | Japan | 1996 | Operable | UB | | 37.220 |
| 34 | Mobile work-shop | HZ-227SA | No2 | 1 | Japan | 1996 | Operable | Arkhangai, Ikh Tamir | | 100.000 |
| 35 | Dump-truck | KY-220 | 11 ton | 1 | Japan | 1996 | Operable | UB | | 160.000 |
| 36 | Dump-truck | KY-220 | 11 ton | 1 | Japan | 1996 | Operable | Sharin Gol | | |
| 37 | Dump-truck | KY-220 | 11 ton | 1 | Japan | 1996 | Operable | Sharin Gol | | |
| 38 | Dump-truck | KY-220 | 11 ton | 1 | Japan | 1996 | Operable | Arkhangai, Ikh Tamir | | 140.000 |
| 39 | Dump-truck | KY-220 | 11 ton | 1 | Japan | 1996 | Operable | UB | | |
| 40 | Dump-truck | KY-220 | 11 ton | 1 | Japan | 1996 | Operable | Sharin Gol | | |
| 41 | Dump-truck | KY-220 | 11 ton | 1 | Japan | 1996 | Operable | UB | | |
| 42 | Dump-truck | KY-220 | 11 ton | 1 | Japan | 1996 | Operable | UB | | |
| 43 | Dump-truck | KY-220 | 11 ton | 1 | Japan | 1996 | Operable | UB | | 87.070 |
| 44 | Dump-truck | KY-220 | 11 ton | 1 | Japan | 1996 | Operable | UB, Baga Nuur | | |
| 45 | Dump-truck | KY-220 | 11 ton | 1 | Japan | 1996 | Operable | Arkhangai, Ikh Tamir | | 120.000 |
| 46 | Dump-truck | KY-220 | 11 ton | 1 | Japan | 1996 | Operable | Sharin Gol | | |
| 47 | Dump-truck | KY-220 | 11 ton | 1 | Japan | 1996 | Operable | Arkhangai, Ikh Tamir | | 100.000 |
| 48 | Dump-truck | KY-220 | 11 ton | 1 | Japan | 1996 | Operable | Arkhangai, Ikh Tamir | | |
| 49 | Dump-truck | KY-220 | 11 ton | 1 | Japan | 1996 | Operable | Sharin Gol | | |
| 50 | Dump-truck | KY-220 | 11 ton | 1 | Japan | 1996 | Operable | Sharin Gol | | |

| No | Equipment | Model | Specification | Q/ty | Country of origin | Produced year | Present condition | Location | Service meter | |
|----|---------------------------|-------------|--------------------|------|-------------------|---------------|-------------------|----------------------|---------------|---------|
| | | | | | | | | | Motor/hour | km |
| 51 | Dump-truck | KY-220 | 11 ton | 1 | Japan | 1996 | Operable | Arkhangai, Ikh Tamir | | 127,000 |
| 52 | Dump-truck | KY-220 | 11 ton | 1 | Japan | 1996 | Operable | UB | | 73,527 |
| 53 | Dump-truck | KY-220 | 11 ton | 1 | Japan | 1996 | Operable | Arkhangai, Ikh Tamir | | 100,000 |
| 54 | Dump-truck | KY-220 | 11 ton | 1 | Japan | 1996 | Operable | Sharin Gol | | |
| 55 | Dump-truck | KY-220 | 11 ton | 1 | Japan | 1996 | Operable | Arkhangai, Ikh Tamir | | 110,000 |
| 56 | Dump-truck | KY-220 | 11 ton | 1 | Japan | 1996 | Operable | UB | | 80,000 |
| 57 | Dump-truck | KY-220 | 11 ton | 1 | Japan | 1996 | Operable | UB | | 34,711 |
| 58 | Dump-truck | KY-220 | 11 ton | 1 | Japan | 1996 | Operable | UB | | 45,225 |
| 59 | Dump-truck | KY-220 | 11 ton | 1 | Japan | 1996 | Operable | Arkhangai, Ikh Tamir | | 170,000 |
| 60 | Dump-truck | KY-220 | 11 ton | 1 | Japan | 1996 | Operable | UB | | |
| 61 | Dump-truck | KY-220 | 11 ton | 1 | Japan | 1996 | Operable | Arkhangai, Ikh Tamir | | 100,000 |
| 62 | Dump-truck | KY-220 | 11 ton | 1 | Japan | 1996 | Operable | Arkhangai, Ikh Tamir | | 120,000 |
| 63 | Dump-truck | KY-220 | 11 ton | 1 | Japan | 1996 | Operable | UB | | 39,700 |
| 64 | Electro-generator | SD-6-60S | 45KUA | 1 | Japan | 1996 | Operable | Tuv, Erdene sum | | |
| 65 | Electro-generator | SD-6-60S | 45KUA | 1 | Japan | 1996 | Operable | Arkhangai, Ikh Tamir | 4,541 | |
| 66 | Electro-generator | SD-6-60S | 45KUA | 1 | Japan | 1996 | Operable | Arkhangai, Ikh Tamir | | |
| 67 | Electro-generator | SD-6-60S | 45KUA | 1 | Japan | 1996 | Operable | Arkhangai, Ikh Tamir | | |
| 68 | Electro-generator | SD-6-60S | 45KUA | 1 | Japan | 1996 | Operable | UB | | |
| 69 | Concrete mixer | PSM-18HE-FL | 0.5 m ³ | 1 | Japan | 1996 | Operable | UB | | |
| 70 | Vibratory Plate Compacter | LF-110 | 110 kg | 1 | Japan | 1996 | Operable | UB | | |
| 71 | Vibratory Plate Compacter | LF-110 | 110 kg | 1 | Japan | 1996 | Operable | UB | | |
| 72 | Vibratory Plate Compacter | LF-90 | 90 kg | 1 | Japan | 1996 | Operable | UB | | |
| 73 | Vibratory Plate Compacter | LF-90 | 90 kg | 1 | Japan | 1996 | Operable | UB | | |

| No | Equipment | Model | Specification | Q/ty | Country of origin | Produced year | Present condition | Location | Service meter | |
|----|----------------------------------|--------------|---------------|------|-------------------|---------------|-------------------|----------------------|---------------|---------|
| | | | | | | | | | Motor/hour | km |
| 74 | Vibratory Plate Compactor | LF-90 | 90 kg | 1 | Japan | 1996 | Operable | UB | | |
| 75 | Vibratory Plate Compactor | LF-90 | 90 kg | 1 | Japan | 1996 | Operable | UB | | |
| 76 | Compressor | PDS-265-414 | 30 kg | 1 | Japan | 1996 | Operable | UB | | |
| 77 | Compressor | PDS-265-414 | 30 kg | 1 | Japan | 1996 | Operable | UB | | |
| 78 | Compressor | PDS-265-414 | 30 kg | 1 | Japan | 1996 | Operable | UB | | |
| 79 | Compressor | PDS-265-414 | 30 kg | 1 | Japan | 1996 | Operable | UB | | |
| 80 | Asphalt sprayer (auto) | FK-615HAL | 25-30 l/min | 1 | Japan | 1996 | Operable | UB | | |
| 81 | Asphalt sprayer (hand) | TES-200 | 25 l/min | 1 | Japan | 1996 | Operable | UB | | |
| 82 | Radio communication | FTL-1011/10 | | 1 | Japan | 1996 | Operable | Arkhangai, Ikh Tamir | | |
| 83 | Laboratory testing equipments | Complete set | | 1 | Japan | 1996 | Operable | Arkhangai, Ikh Tamir | | |
| 84 | Wheeler for carrying explosives | HZ-J75LP-MR | 1 ton | 1 | Japan | 1996 | Operable | UB | | |
| 85 | Dump truck | BY-211LTM | 4 ton | 1 | Japan | 1996 | Operable | Arkhangai, Ikh Tamir | | |
| 86 | Small truck | BY-100LPCB | 1.5 ton | 1 | Japan | 1996 | Operable | Arkhangai, Ikh Tamir | | 126.037 |
| 87 | Micro bus | TCR-10LRPS | | 1 | Japan | 1996 | Operable | UB | | |
| 88 | Crusher | PGJ-6 | 90 ton/h | 1 | Japan | 1996 | Operable | Tuv, Erdene | | |
| 89 | Crusher | PFJ-4 | 30 ton/h | 1 | Japan | 1996 | Operable | Tuv, Erdene | | |
| 90 | Asphalt plant | NR-600BR | 30 ton/h | 1 | Japan | 1996 | Operable | Tuv, Erdene | | |
| 91 | Hand guide type vibration roller | LP-650 | 0.6 ton | 1 | Japan | 1996 | Operable | UB | | |

表-2 ウランバートル道路建設維持会社の機材

EQUIPMENT LIST OF THE "ULAAANBAATAR ZAM ZASVAR" COMPANY (State)

| NO | Equipment | Model | Specification | Q/ty | Country of origin | Produced year | Present condition | Service meter | |
|----|-------------------|-------------|---------------|------|-------------------|---------------|-------------------|---------------|--------|
| | | | | | | | | Motor/hour | km |
| 1 | Dump truck | MINZ 4505 | 6 ton | 1 | Russia | 1988 | Operable | | 168349 |
| 2 | Dump truck | MINZ 4505 | 6 ton | 1 | Russia | 1988 | Operable | | 199111 |
| 3 | Dump truck | MINZ 4505 | 6 ton | 1 | Russia | 1988 | Operable | | 195378 |
| 4 | Dump truck | MINZ 4505 | 6 ton | 1 | Russia | 1989 | Under repair | | 146557 |
| 5 | Dump truck | MINZ 554 | 5 ton | 1 | Russia | 1993 | Operable | | 125615 |
| 6 | Dump truck | MINZ 441510 | 7.5 ton | 1 | Russia | 1995 | Under repair | | 60403 |
| 7 | Dump truck | MINZ 4503 | 7.5 ton | 1 | Russia | 1993 | Operable | | 42079 |
| 8 | Dump truck | MAZ 5541 | 9.5 ton | 1 | Russia | 1995 | Operable | | 36947 |
| 9 | Dump truck | MAZ 5549 | 9.5 ton | 1 | Russia | 1989 | Operable | | 148910 |
| 10 | Micro bus | UAZ 33206 | 12 people | 1 | Russia | 1997 | Operable | | 88034 |
| 11 | Jeep | UAZ 316126 | | 1 | Russia | 1995 | Operable | | |
| 12 | Crane | KS 2561 | 6.3 ton | 1 | Russia | 1988 | Operable | 3860.5 | 70354 |
| 13 | Dump truck | EY 415 JDL | 15 ton | 1 | Korea | 1995 | Operable | | 72172 |
| 14 | Bitumen spreader | DS 395 | | 1 | Russia | 1996 | Operable | | 610 |
| 15 | Truck | GAZ 53 | | 1 | Russia | 1989 | Operable | | 38324 |
| 16 | Motor grader | DZ 122 | | 1 | Russia | 1988 | Operable | 2848 | 4889 |
| 17 | Macadam roller | DU 47 | | 1 | Russia | 1995 | Operable | 447 | |
| 18 | Macadam roller | DU 47 | | 1 | Russia | 1996 | Operable | 408 | |
| 19 | Macadam roller | DU 47 | | 1 | Russia | 1994 | Operable | 436 | |
| 20 | Macadam roller | DU 48 | | 1 | Russia | 1998 | Operable | | |
| 21 | Compressor | EO 2621 | | 1 | Russia | 1986 | Operable | | |
| 22 | Compressor | PR 10 | | 1 | Russia | 1999 | Operable | | |
| 23 | Compressor | PR 10 | | 1 | Russia | 1988 | Under repair | | |
| 24 | Compressor | PR 1018 | | 1 | Russia | 1982 | Under repair | | |
| 25 | Bulldozer | DZ 42 | | 1 | Russia | 1988 | Scrap | | |
| 26 | Back hoe | Robex 1300 | | 1 | Korea | 1995 | Operable | | |
| 27 | Back hoe | Robex 2000 | | 1 | Korea | 1995 | Operable | | |
| 28 | Back hoe | Robex 2800 | | 1 | Korea | 1999 | Operable | | |
| 29 | Trailer | | | 1 | Russia | 1980 | Operable | | |
| 30 | Welding apparatus | SAK | | 1 | Russia | 1988 | Operable | | |
| 31 | Welding apparatus | | | 1 | Russia | 1988 | Operable | | |

| NO | Equipment | Model | Specification | Q/ty | Country of origin | Produced year | Present condition | Service meter | |
|----|---------------------------|------------|---------------|------|-------------------|---------------|-------------------|---------------|--------|
| | | | | | | | | Motor/hour | km |
| 32 | Asphalt cutter | | | 1 | Russia | 1999 | Operable | | |
| 33 | Asphalt cutter | | | 1 | Russia | 1999 | Operable | | |
| 34 | Air compressor | | | 1 | Russia | 1988 | Operable | | |
| 35 | Mobile asphalt drum mixer | DHBB 25 | | 1 | China | 1999 | Operable | | |
| 36 | Dump truck | KAMAZ 5511 | 10 ton | 1 | Russia | 1988 | Scrap | | 226440 |
| 37 | Dump truck | KAMAZ 5511 | 10 ton | 1 | Russia | 1988 | Scrap | | 168803 |
| 38 | Dump truck | KAMAZ 5511 | 10 ton | 1 | Russia | 1988 | Operable | | 118651 |
| 39 | Dump truck | KAMAZ 5511 | 10 ton | 1 | Russia | 1988 | Under repair | | 215310 |
| 40 | Dump truck | KAMAZ 5511 | 10 ton | 1 | Russia | 1988 | Under repair | | 171679 |
| 41 | Dump truck | KAMAZ 5511 | 10 ton | 1 | Russia | 1988 | Under repair | | 197702 |
| 42 | Dump truck | KAMAZ 5511 | 10 ton | 1 | Russia | 1989 | Scrap | | 176133 |
| 43 | Dump truck | KAMAZ 5511 | 10 ton | 1 | Russia | 1989 | Under repair | | 119231 |
| 44 | Dump truck | KAMAZ 5511 | 9 ton | 1 | Russia | 1987 | Under repair | | 155311 |
| 45 | Dump truck | KAMAZ 5511 | 9 ton | 1 | Russia | 1987 | Under repair | | 155362 |
| 46 | Truck | ZIL 130 | 6 ton | 1 | Russia | 1986 | Operable | | 256150 |
| 47 | Tanker lorry | ZIL 130 | 6 ton | 1 | Russia | 1986 | Operable | 4113 | 101257 |
| 48 | Tanker lorry | TSB 6 | 6 ton | 1 | Russia | 1988 | Scrap | | 62017 |
| 49 | Crane | KS 2561 | 5 ton | 1 | Russia | 1989 | Operable | 3537 | 17816 |
| 50 | Truck | KRAZ 255 | | 1 | Russia | 1989 | Operable | | 109671 |
| 51 | Motor grader | DZ 122 | 120 HP | 1 | Russia | 1990 | Under repair | | |
| 52 | Tire roller | DU 16 | 10 ton | 1 | Russia | 1985 | Operable | 5642 | |
| 53 | Dump truck | MAZ 5549 | 9 ton | 1 | Russia | 1987 | Operable | 5436 | |
| 54 | Bus | PAZ 672 | | 1 | Russia | 1989 | Operable | | 139139 |
| 55 | Macadam roller | DU 48 | 12 ton | 1 | Russia | 1986 | Operable | | 146172 |
| 56 | Semi trailer | ChMZAP | 40 ton | 1 | Russia | 1989 | Operable | 3061 | |
| 57 | Truck | GAZ 3307 | 5 ton | 1 | Russia | 1993 | Operable | | 74307 |
| 58 | Asphalt finisher | DS 195 | | 1 | Russia | 1995 | Under repair | 559 | |

表-3 国営会社「AZZAN」の機材

EQUIPMENT LIST OF THE ROAD REPAIR AND MAINTENANCE
COMPANY "AZZAN" (State)

| No. | Equipment | Model | Specification | Q/ty | Country of origin | Produced year | Present condition |
|-----|----------------------|-------------|---------------|------|-------------------|---------------|-------------------|
| 1 | Truck | ZIL-130 | 5 ton | 1 | Russia | 1985 | Good |
| 2 | Truck | GAZ-53 | 3 ton | 1 | Russia | 1986 | Good |
| 3 | Water lorry | ZIL-130 | 6000 L | 1 | Russia | 1999 | Good |
| 4 | Dump truck | ZIL-555 | | 1 | Russia | 1986 | Fair |
| 5 | Dump truck | ZIL-555 | | 1 | Russia | 1985 | Fair |
| 6 | Dump truck | ZIL-555 | | 1 | Russia | 1988 | Fair |
| 7 | Dump truck | ZIL-5054 | | 1 | Russia | 1993 | Good |
| 8 | Dump truck | ZIL-555 | | 1 | Russia | 1985 | Fair |
| 9 | Dump truck | KAMAZ-5511 | | 1 | Russia | 1990 | Fair |
| 10 | Dump truck | KRAZ-256 | 12 ton | 1 | Russia | 1988 | Fair |
| 11 | Bitumen lorry | KAMAZ-53213 | | 1 | Russia | 1989 | Fair |
| 12 | Bitumen lorry | KAMAZ-53213 | | 1 | Russia | 1990 | Fair |
| 13 | Bitumen lorry | KAMAZ-53213 | | 1 | Russia | 1990 | Fair |
| 14 | Bitumen lorry | KAMAZ-53213 | | 1 | Russia | 1990 | Fair |
| 15 | Agitator truck | KAMAZ-54112 | | 1 | Russia | 1989 | Fair |
| 16 | Agitator truck | KAMAZ-54112 | | 1 | Russia | 1989 | Fair |
| 17 | Agitator truck | KAMAZ-54112 | | 1 | Russia | 1990 | Fair |
| 18 | Agitator truck | KAMAZ-54112 | | 1 | Russia | 1990 | Fair |
| 19 | Truck | ZIL-131 | | 1 | Russia | 1988 | Bad |
| 20 | Mobile workshop | GAZ-66 | | 1 | Russia | 1988 | Bad |
| 21 | Snow removal machine | ZIL-1314 | | 1 | Russia | 1990 | Good |
| 22 | Cement truck | ZIL-130 | | 1 | Russia | 1990 | Fair |
| 23 | Truck crane | KE-4561 | | 1 | Russia | 1984 | Fair |
| 24 | Dump truck | ZIL-4505 | | 1 | Russia | 1987 | Fair |
| 25 | Dump truck | ZIL-4505 | | 1 | Russia | 1987 | Good |
| 26 | Dump truck | ZIL-4505 | | 1 | Russia | 1987 | Good |
| 27 | Truck crane | KRAZ-256 | 16 ton | 1 | Russia | 1988 | Fair |
| 28 | Motor grader | DZ-180 | | 1 | Russia | 1994 | Fair |
| 29 | Motor grader | DZ-143 | | 1 | Russia | 1990 | Fair |
| 30 | Excavator | JCB | | 1 | | 1996 | Good |
| 31 | Excavator | EO-2621 | | 1 | Russia | 1989 | Fair |
| 32 | Wheel loader | TO-18 | | 1 | Russia | 1991 | Fair |
| 33 | Tractor | UMZ-6 | 50 HP | 1 | Russia | 1986 | Not operable |
| 34 | Asphalt finisher | DS-143 | 3.5 m | 1 | Russia | 1991 | Good |
| 35 | Macadam roller | DU-47 | 5 ton | 1 | Russia | 1990 | Fair |
| 36 | Macadam roller | DU-47 | 5 ton | 1 | Russia | 1987 | Fair |
| 37 | Macadam roller | DU-47 | 5 ton | 1 | Russia | 1987 | Fair |
| 38 | Bulldozer | DZ-116 | 116 HP | 1 | Russia | 1988 | Fair |
| 39 | Bulldozer | DZ-110 | 110 HP | 1 | Russia | 1991 | Fair |
| 40 | Bulldozer | DZ-42 | | 1 | Russia | 1990 | Fair |
| 41 | Trailer | 4 MZAP | | 1 | Russia | 1991 | Fair |
| 42 | Motor grader | DZ-122 | 2.8 m | 1 | Russia | 1986 | Fair |
| 43 | Excavator | EO-2621 | | 1 | Russia | 1985 | Good |
| 44 | Bulldozer | D-606 | | 1 | Russia | 1985 | Fair |
| 45 | Macadam roller | DU-47 | 5 ton | 1 | Russia | 1989 | Fair |
| 46 | Air compressor | PR-10 | 6 atm. | 1 | Russia | 1986 | Fair |
| 47 | Air compressor | PR-10 | 6 atm. | 1 | Russia | 1990 | Fair |
| 48 | Air compressor | PKS-5.25 | | 1 | Russia | 1988 | Fair |
| 49 | Welding apparatus | SAK | | 1 | Russia | 1993 | Fair |

| No. | Equipment | Model | Specification | Q/ty | Country of origin | Produced year | Present condition |
|-----|-------------------|----------|---------------|------|-------------------|---------------|-------------------|
| 50 | Welding apparatus | SAK-16 | | 1 | Russia | 1986 | Fair |
| 51 | Welding apparatus | TD-300 | | 1 | Russia | 1985 | Not operable |
| 52 | Welding apparatus | TD-300 | | 1 | Russia | 1986 | Not operable |
| 53 | Welding apparatus | PSO-300 | | 1 | Russia | 1987 | Not operable |
| 54 | Welding apparatus | TDM-401 | | 1 | Russia | 1992 | Good |
| 55 | Welding apparatus | TDM-401 | | 1 | Russia | 1990 | Good |
| 56 | Welding apparatus | TDM-401 | | 1 | Russia | 1990 | Fair |
| 57 | Welding apparatus | BB-400 | | 1 | Russia | 1992 | Good |
| 58 | Drilling machine | 211-1353 | | 1 | Russia | 1990 | Good |
| 59 | Drilling machine | 2M-112 | | 1 | Russia | 1989 | Fair |
| 60 | Grindstone | | | 1 | Russia | 1985 | Fair |
| 61 | Vibration roller | | | 1 | Russia | 1993 | Good |
| 62 | Steamer | E-01 | | 1 | Russia | 1989 | Good |
| 63 | Steamer | E-01 | | 1 | Russia | 1996 | Good |
| 64 | Asphalt mixer | DE-117 | | 1 | Russia | 1988 | Fair |
| 65 | Asphalt mixer | DE-117 | | 1 | Russia | 1987 | Fair |
| 66 | Asphalt mixer | D-508 | | 1 | Russia | 1985 | Not operable |
| 67 | Concrete mixer | SB-75 | | 1 | Russia | 1987 | Good |
| 68 | Clay mixer | | | 1 | Russia | 1989 | Not operable |
| 69 | Crusher | CM-561 | | 1 | Russia | 1987 | Not operable |
| 70 | Compactor | | | 1 | Great Britain | 1997 | Good |
| 71 | Compactor | | | 1 | Great Britain | 1997 | Good |
| 72 | Bitumen sprayer | | | 1 | Great Britain | 1997 | Good |
| 73 | Cutter | | | 1 | China | 1999 | Good |

表-4 民間会社「BATZAM」の機材

EQUIPMENT LIST OF THE "BATZAM" COMPANY (Private)

| No. | Equipment | Model | Specification | Q/ty | Country of origin | Produced year | Present condition |
|-----|--------------------------------|----------|---------------------|------|-------------------|---------------|-------------------|
| 1 | Dump truck | ZIL-4505 | 5 ton | 5 | Russia | 1990 | Good |
| 2 | Truck | GAZ-53 | 3 ton | 1 | Russia | 1990 | Good |
| 3 | Water lorry | KO-002 | 6000 L | 1 | Russia | 1989 | Fair |
| 4 | Bulldozer | DZ-110 | 110 HP | 1 | Russia | 1987 | Under repair |
| 5 | Macadam roller | DU-47 | 5 ton | 1 | Russia | 1987 | Fair |
| 6 | Macadam roller | DU-48 | 10 ton | 1 | Russia | 1990 | Good |
| 7 | Excavator | EO-3322 | 0.65 m ³ | 1 | Russia | 1991 | Good |
| 8 | Motor grader | DZ-122 | 2.8 m | 1 | Russia | 1990 | Fair |
| 9 | Asphalt finisher | DS-126 | 3.5 m | 1 | Russia | 1985 | Under repair |
| 10 | Tractor | UMZ-6 | 50 HP | 1 | Russia | 1986 | Fair |
| 11 | Dump truck trailer with 1 beam | | 5 ton | 5 | Russia | 1986 | Fair |
| 12 | Truck trailer with 2 beam | | 3 ton | 1 | Russia | 1991 | Fair |
| 13 | Welding apparatus | | 380 V | 2 | Russia | 1997 | Good |
| 14 | Mechanical tackle | | 2 ton | 1 | Russia | 1993 | Good |
| 15 | Vice | | | 1 | Russia | 1990 | Fair |
| 16 | Grindstone | | | 1 | Russia | 1993 | Good |
| 17 | Saw, plane | | | 1 | Russia | 1997 | Good |
| 18 | Welding apparatus | SAK | | 1 | Russia | 1997 | Fair |
| 19 | Air compressor | PR-10 | 6 atm | 1 | Russia | 1993 | Good |
| 20 | Level | | | 1 | Russia | 1998 | Good |
| 21 | Theodolite | | | 1 | Russia | 1994 | Good |
| 22 | Tank for bitumen | | | 1 | Russia | 1996 | Good |
| 23 | Square vibrator | | | 1 | Russia | 1992 | Fair |
| 24 | Deep vibrator | | | 1 | Russia | 1992 | Fair |
| 25 | Form for border | | | 3 | Russia | 1995 | Good |
| 26 | Hand roller | | | 1 | Russia | 1994 | Good |
| 27 | Asphalt cutter | | | 1 | Russia | 1996 | Good |

表-5 民営会社「ASBI」の機材

EQUIPMENT LIST OF THE "ASBI" COMPANY (Private)

| No. | Equipment | Model | Specification | Q/ty | Country of origin | Produced year | Present condition |
|-----|--------------------|---------|---------------------|-----------|-------------------|---------------|-------------------|
| 1 | Bulldozer | T 130 | 22 ton | 1 | Russia | 1985 | Good |
| 2 | Motor grader | DZ-122A | 180 HP | 1 | Russia | 1990 | Good |
| | | DZ 57 | | 1 | Russia | 1994 | Good |
| 3 | Back hoe | EO-3322 | 0.5 m ³ | 2 | Russia | 1991 | Good |
| | | EO-2621 | 0.65 m ³ | 1 | Russia | 1989 | Good |
| 4 | Macadam roller | DU-47 | 5 ton | 1 | Russia | 1987 | Good |
| | | DU-48 | 8 ton | 1 | China | 1988 | Good |
| 5 | Tire roller | ZL-14 | 14 ton | 1 | Russia | 2000 | Good |
| 6 | Concrete mixer | SB-92 | 4 m ³ | 1 | Russia | 1993 | Good |
| 7 | Crane | KS-4561 | 16 ton | 1 | Russia | 1989 | Good |
| | | KS-2561 | 5 ton | 1 | Russia | 1992 | Good |
| 8 | Scraper | DZ-357 | 8 m ³ | 2 | Russia | 1988 | Fair |
| 9 | Dump truck | ZIL 555 | 5 ton | 10 | Russia | 1987-1996 | Good |
| 10 | Semi trailer | | 40 ton | 1 | Russia | 1988 | Fair |
| | | | 20 ton | 1 | Russia | 1988 | Fair |
| 11 | Water lorry | | 5 ton | 2 | Russia | 1994 | Good |
| 12 | Compressor | PR 10 | 110 HP | 1 | Russia | 1995 | Good |
| 13 | Tractor | MTZ 50 | 50 HP | 1 | Russia | 1990 | Good |
| 14 | Truck | GAZ 53 | 4 ton | 1 | Russia | 1987 | Good |
| | | ZIL 130 | 6 ton | 1 | Russia | 1987 | Good |
| 15 | Car | UAZ 469 | 7people | 1 | Russia | 1998 | Good |
| | | BENZ | | 1 | Germany | 1998 | Good |
| 16 | Microbus | UAZ 452 | 12 people 1ton | 1 | Russia | 1998 | Good |
| 17 | Asphalt sprayer | | 5 ton | 2 | Russia | 1992 | Good |
| 18 | Asphalt finisher | DS 126 | 8m ³ | 2 | Russia | 1985 | Good |
| 19 | Portable welding | SAK | | 2 | Russia | 1997 | Good |
| 20 | Fuel lorry | | 8 ton | 1 | Russia | 1996 | Good |
| 21 | Concrete cutter | | 30 cm | 1 | Russia | 1995 | Good |
| 22 | Compactor (hand) | | 40 x 40 | 1 | Russia | 1996 | Good |
| 23 | Accommodation | | | 2 | Russia | 1995 | Good |
| 24 | Total station | SET 6 | | 1 | Japan | 1996 | Good |
| 25 | Level | NI 2 | | 1 | Germany | 1997 | Good |
| 26 | Nuclear densometer | | | 1 | USA | 1999 | Good |
| 27 | Sand cone | | | 1 | Germany | 1999 | Good |
| | TOTAL | | | 50 | | | |

表-6 民営会社「HUCHITZAM」の機材

EQUIPMENT LIST OF THE “HUCHITZAM” COMPANY (Private)

| No. | Equipment | Model | Specification | Q/ty | Country of origin | Produced year | Present condition |
|-----|--------------------|------------|---------------------|------|-------------------|---------------|-------------------|
| 1 | Dump truck | ZIL-4505 | 5 ton | 1 | Russia | 1990 | Fair |
| 2 | Dump truck | ZIL-4505 | 5 ton | 1 | Russia | 1993 | Good |
| 3 | Dump truck | ZIL-4505 | 5 ton | 1 | Russia | 1987 | Fair |
| 4 | Dump truck | KRAZ-256 | 12 ton | 1 | Russia | 1978 | Fair |
| 5 | Dump truck | KRAZ-256 | 12 ton | 1 | Russia | 1989 | Fair |
| 6 | Dump truck | KRAZ-256 | 12 ton | 1 | Russia | 1976 | Fair |
| 7 | Truck | ZIL-130 | 5 ton | 1 | Russia | 1979 | Fair |
| 8 | Water lorry | ZIL-130 | 6 ton | 1 | Russia | 1988 | Fair |
| 9 | Truck crane KRAZ | KS-4561 | 16 ton | 1 | Russia | 1982 | Fair |
| 10 | Scraper | MOAZ D-357 | 15 ton | 1 | Russia | 1988 | Good |
| 11 | Scraper | MOAZ D-357 | 15 ton | 1 | Russia | 1989 | Fair |
| 12 | Scraper | MOAZ D-357 | 15 ton | 1 | Russia | 1985 | Fair |
| 13 | Scraper | MOAZ D-357 | 15 ton | 1 | Russia | 1988 | Fair |
| 14 | Motor grader | D-557 | 2.8 m | 1 | Russia | 1989 | Fair |
| 15 | Motor grader | D-557 | 2.8 m | 1 | Russia | 1986 | Fair |
| 16 | Tractor | MTZ-510 | 65 HP | 1 | Russia | 1992 | Fair |
| 17 | Tire Roller | DU-16 | 25 ton | 1 | Russia | 1987 | Good |
| 18 | Macadam roller | DU-47 | 5 ton | 1 | Russia | 1990 | Fair |
| 19 | Macadam roller | DU-48 | 10 ton | 1 | Russia | 1989 | Fair |
| 20 | Bulldozer | T-130 | 22 ton | 1 | Russia | 1990 | Fair |
| 21 | Excavator | EO-3322 | 0.65 m ³ | 1 | Russia | 1988 | Fair |
| 22 | Asphalt finisher | DS-126 | 3.5 m | 1 | Russia | 1987 | Fair |
| 23 | Air compressor | PR-10 | 6 atm. | 1 | Russia | - | Fair |
| 24 | Welding apparatus | SAK | | 1 | Russia | - | Good |
| 25 | Hand roller | | | 1 | Russia | - | Fair |
| 26 | Electric generator | NSh-60 | 380 V | 1 | Russia | - | Fair |
| 27 | Electric generator | UD-25 | 220 V | 1 | Russia | - | Good |
| 28 | Water pump | WB-20x | 1 ton/min | 1 | Russia | - | Good |
| 29 | Welding apparatus | | | 1 | Russia | - | Good |

表-7 民営会社「GAN GUUR」の機材

EQUIPMENT LIST OF THE "GAN GUUR" COMPANY (Private)

| No. | Equipment | Model | Specification | Q/ty | Country of origin | Produced year | Present condition |
|-----|-----------------------------|--------------------|-----------------------|------|-------------------|---------------|-------------------|
| 1 | Vehicles | ZIL-130 | 5 ton | 3 | Russia | 1988-1999 | 1 under repair |
| 2 | | ZIL-555 | 4.5 ton | 3 | Russia | 1988-1999 | 1 under repair |
| 3 | | ZIL-4121 | 5.5 ton | 4 | Russia | 1992-1998 | Operable |
| 4 | | KRAZ-256 | 12 ton | 2 | Russia | 1989-1999 | Operable |
| 5 | Water lorry | ZIL -130 | 5 ton | 1 | Russia | 1988 | Operable |
| 6 | Truck Crane | KS-5363 | 25 ton | 1 | Russia | 1995 | Operable |
| 7 | | KS-4560 | 16 ton | 1 | Russia | 1989 | Operable |
| 8 | | KRAZ-256 | 16 ton | 2 | Russia | 1988-1999 | Operable |
| 9 | Excavator | EO-5111 | 1 m ³ | 1 | Russia | 1992 | Operable |
| 10 | | EO-3322 | 0.65 | 1 | Russia | 1988 | Operable |
| 11 | Roller | DU-16 | 10 ton | 1 | Russia | 1989 | Operable |
| 12 | | DU-45 | 5 ton | 1 | Russia | 1999 | Operable |
| 13 | | DU-5 | 2 ton | 1 | Russia | 1995 | Operable |
| 14 | Bulldozer | DZ-130 | 100 HP | 1 | Russia | 1994 | Operable |
| 15 | Agitator truck | KAMAZ-5555 | 4 m ³ | 1 | Russia | 1989 | Operable |
| 16 | Electric generator | JES-60 | 60 kW | 3 | Russia | 1989-1998 | Operable |
| 17 | | JES-30 | 30 kW | 1 | Russia | 1995 | Operable |
| 18 | Concrete mixer | SM-10 | 0.33 m ³ | 1 | Russia | 1989 | Operable |
| 19 | | SM-5 | 0.15 m ³ | 1 | Russia | 1989 | Operable |
| 20 | Reinforcing bar cutter | SMJ-270 | 40 mm | 3 | Russia | 1989-1997 | Operable |
| 21 | Reinforcing bar bender | SMJ-310 | 40 mm | 2 | Russia | 1988-1996 | Operable |
| 22 | Water pump | S-245 | 120 m ³ /h | 5 | Russia | 1988-1995 | Operable |
| 23 | Diesel breaker | S-2300 | 5 ton | 1 | Russia | 1989 | Operable |
| 24 | Deep vibrator | IM-16 | 50m ³ | 5 | Russia | 1989-1997 | Operable |
| 25 | Square vibrator | IM-47 | 1 m ² | 2 | Russia | 1988 | Operable |
| 26 | Trailer | M-20 | 20 ton | 1 | Russia | 1999 | Operable |
| 27 | 1 and 2 beam truck trailers | ZIL-130 ZIL-555 | 5 ton | 4 | Russia | 1988-1994 | Operable |

表-8 民営会社「TECHNO ARCH」の機材

EQUIPMENT LIST OF THE "TECHNO-ARCH" COMPANY (Private)

| No. | Equipment | Model | Specification | Q/ty | Country of origin | Produced year | Present condition |
|-----|------------------------|----------|-------------------|------|-------------------|---------------|-------------------|
| 1 | Crane | KS-4361 | 16 ton | 1 | Russia | 1988 | Operable |
| 2 | Dump truck | ZIL-4505 | 5 ton | 1 | Russia | 1989 | Operable |
| 3 | Concrete mixer | SB-16 | 330 L | 1 | Russia | 1991 | Operable |
| 4 | Concrete mixer | S-80 | 167 L | 1 | Russia | 1992 | Operable |
| 5 | Reinforcing bar bender | S-1465 | 40 mm | 1 | Russia | 1989 | Operable |
| 6 | Reinforcing bar cutter | S-333 | 40 mm | 1 | Russia | 1986 | Operable |
| 7 | Welding apparatus | TD-500 | 400 A | 1 | Russia | 1989 | Operable |
| 8 | Square vibrator | UB-112 | 36 V | 1 | Russia | 1989 | Operable |
| 9 | Deep vibrator | UB-47 | 36 V | 2 | Russia | 1989 | Operable |
| 10 | Air compressor | ZIP-54 | 7 atm. | 1 | Russia | 1986 | Operable |
| 11 | Motor pump | MG-40 G | 63 ton | 1 | Russia | 1990 | Operable |
| 12 | Air receiver | R-10 | 10 m ³ | 1 | Russia | 1992 | Operable |
| 13 | Bulk cement storage | ZTA-100 | 400 ton | 4 | Russia | 1995 | Operable |
| 14 | Electric substation | TP10/04 | 250 kVA | 1 | Russia | 1992 | Operable |
| 15 | Diesel station | ADS-30 | 37.5 kW | 1 | Russia | 1989 | Operable |
| 16 | Winch | TL-3 | 3 ton | 1 | Russia | 1992 | Operable |
| 17 | Lathe machine | ZB-631 | 360 mm | 1 | Russia | 1993 | Operable |
| 18 | Drilling machine | 2B-132 | 19 mm | 1 | Russia | 1986 | Operable |
| 19 | Lathe machine | Titan | 250 mm | 1 | Russia | 1980 | Operable |
| 20 | Guillotine cutter | N-3314 | 1600 mm | 1 | Russia | 1989 | Operable |
| 21 | Level | NV-3 | - | 1 | Russia | 1992 | Operable |
| 22 | Theodolite | 2T-5 | - | 1 | Russia | 1989 | Operable |
| 23 | Form for big border | - | 2x20 pcs | 2 | Russia | 1995 | Operable |
| 24 | Form for small border | - | 1x40 pcs | 1 | Russia | 1993 | Operable |
| 25 | Form for pipe | - | D-1 m | 2 | Russia | 1991 | Operable |
| 26 | Form for beam | - | L-15 m | 1 | Russia | 1988 | Operable |
| 27 | ZHT-5 form | - | 2 x 2 S | 2 | Russia | 1989 | Operable |

表－9 国営リース会社「TTTurees」の機材

EQUIPMENT LIST OF THE EQUIPMENT LEASING “TTTurees” COMPANY (State)

| No. | Equipment | Model | Specification | Q/ty | Country of Origin | Produced year | Present condition |
|-----|--|-----------------------|---------------------------------|------|-------------------|---------------|-------------------|
| 1 | Motor grader Komatsu | GD-611 | 2.8 m | 1 | Japan | 1999 | Operable |
| 2 | Motor grader Komatsu | GD-611 | 2.8 m | 1 | Japan | 1999 | Operable |
| 3 | Motor grader Komatsu | GD-611 | 2.8 m | 1 | Japan | 1999 | Operable |
| 4 | Wheel Loader Komatsu | WA-180 | 1.4 m ³ | 1 | Japan | 1999 | Operable |
| 5 | Wheel Loader Komatsu | WA-180 | 1.4 m ³ | 1 | Japan | 1999 | Operable |
| 6 | Excavator Komatsu | PW-150 | 1 m ³ | 1 | Japan | 1999 | Operable |
| 7 | Tire Roller Dynapac | CP-221 | 12.5 ton 21 ton with ballast | 1 | Sweden | 1999 | Operable |
| 8 | Tire Roller Dynapac | CP-221 | 12.5 ton 21 ton with ballast | 1 | Sweden | 1999 | Operable |
| 9 | Tire Roller Dynapac | CP-221 | 12.5 ton 21 ton with ballast | 1 | Sweden | 1999 | Operable |
| 10 | Water lorry with sprayer, broom and cutter | ZIL-130 MDK-433360 | 6,000 L | 1 | Russia | 1998 | Operable |
| 11 | Water lorry with sprayer, broom and cutter | ZIL-130 MDK-433360 | 6,000 L | 1 | Russia | 1998 | Operable |
| 12 | Water lorry with sprayer, broom and cutter | ZIL-130 MDK-433360 | 6,000 L | 1 | Russia | 1998 | Operable |
| 13 | Water lorry with sprayer, broom and cutter | ZIL-130 MDK-433360 | 6,000 L | 1 | Russia | 1998 | Operable |
| 14 | Water lorry with sprayer, broom and cutter | ZIL-130 MDK-433360 | 6,000 L | 1 | Russia | 1998 | Operable |

添付資料 5 - 7 基本設計図

PLAN 1

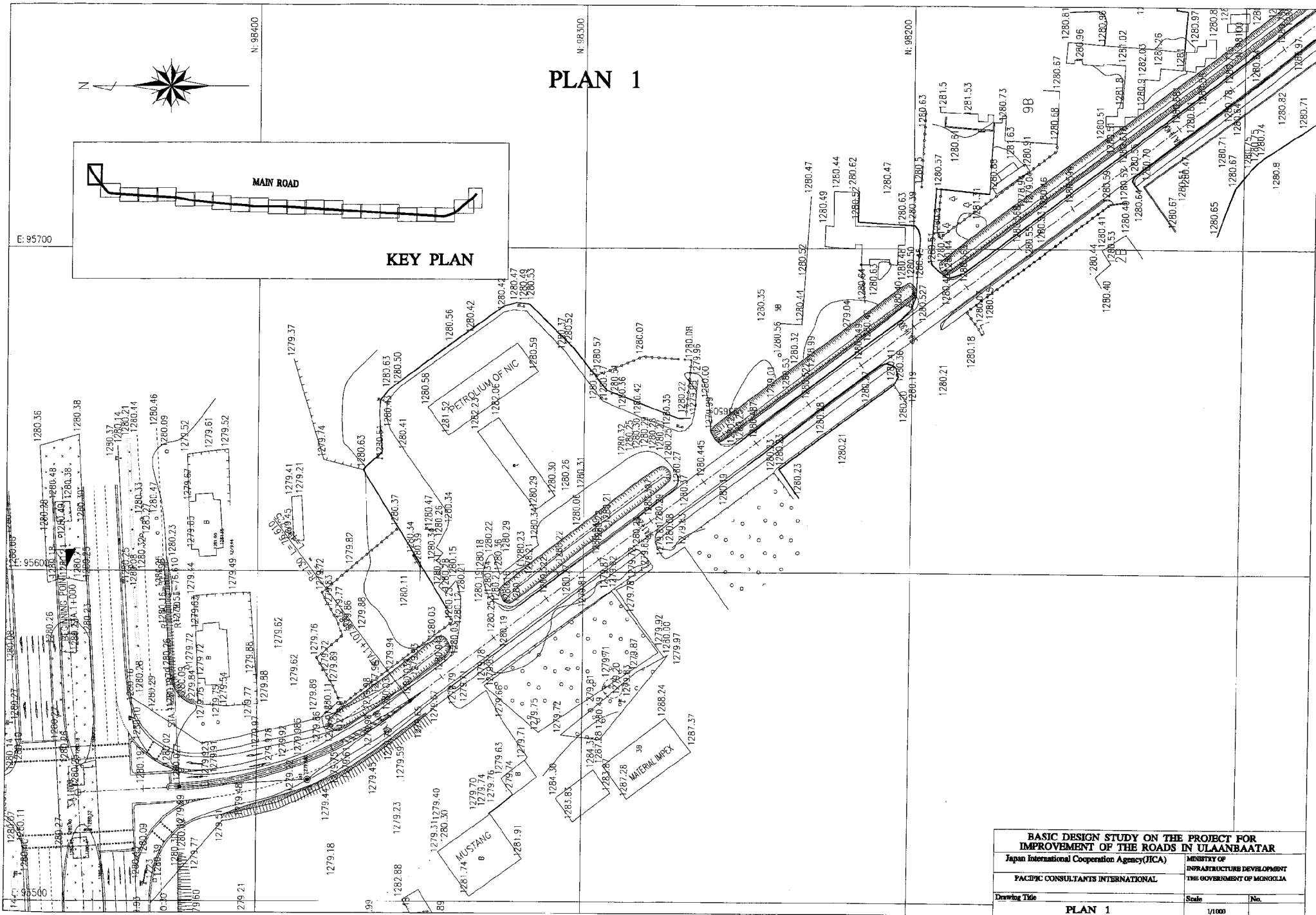
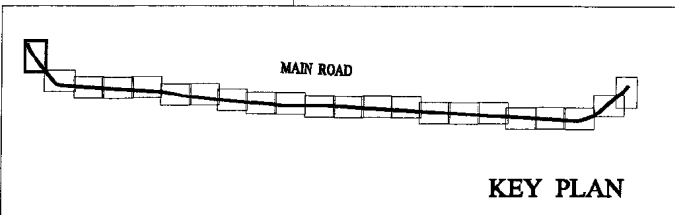

| | |
|--|---|
| BASIC DESIGN STUDY ON THE PROJECT FOR IMPROVEMENT OF THE ROADS IN ULAANBAATAR | |
| Japan International Cooperation Agency (JICA) | MINISTRY OF INFRASTRUCTURE DEVELOPMENT THE GOVERNMENT OF MONGOLIA |
| PACIFIC CONSULTANTS INTERNATIONAL | |
| Drawing Title | Scale No. |
| PLAN 1 | 1/1000 |

PLAN 2

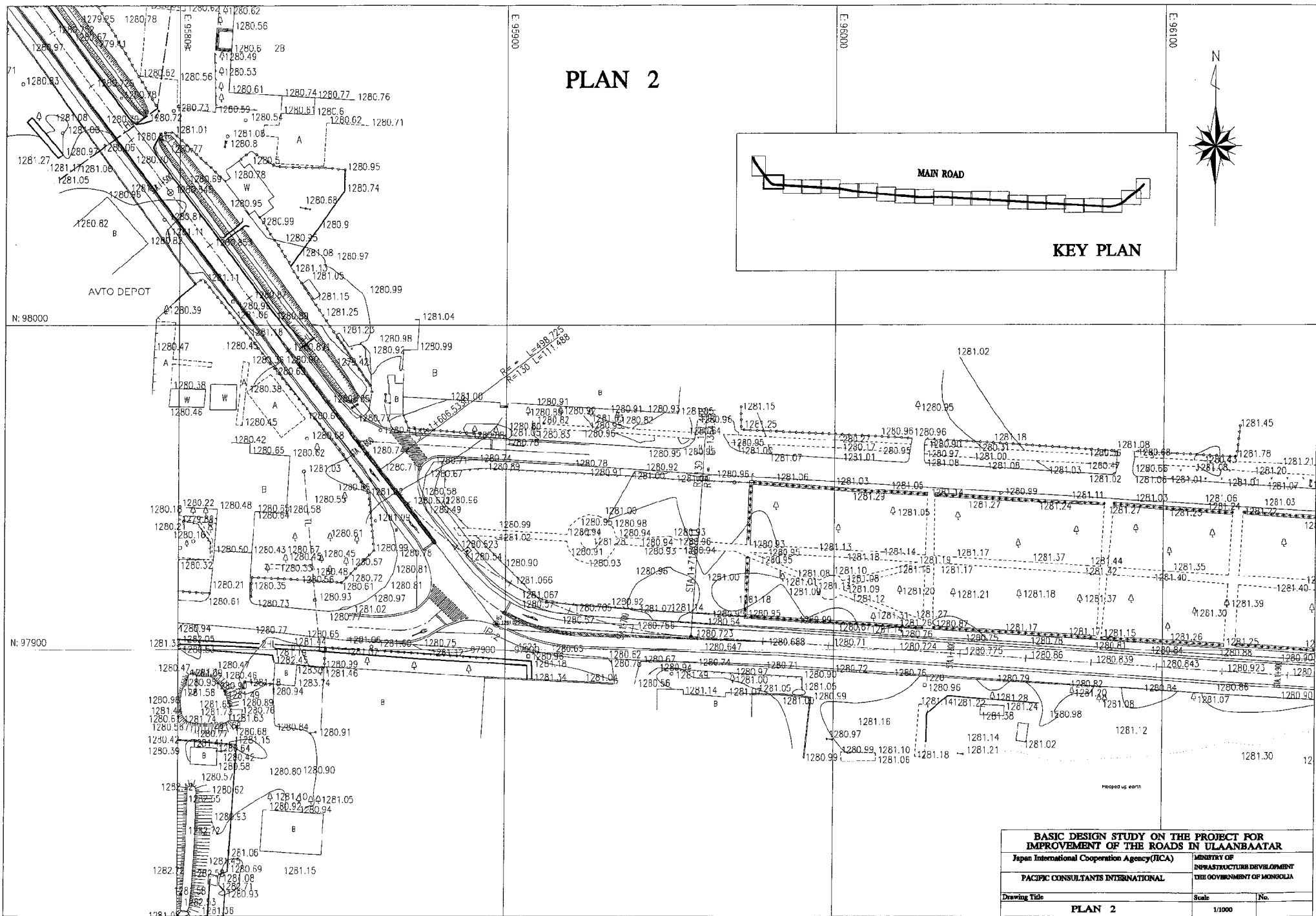
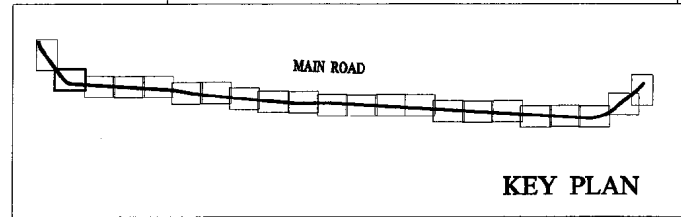

| | | |
|--|--------|---|
| BASIC DESIGN STUDY ON THE PROJECT FOR IMPROVEMENT OF THE ROADS IN ULAANBAATAR | | |
| Japan International Cooperation Agency (JICA) | | MINISTRY OF INFRASTRUCTURE DEVELOPMENT THE GOVERNMENT OF MONGOLIA |
| PACIFIC CONSULTANTS INTERNATIONAL | | |
| Drawing Title | Scale | No. |
| PLAN 2 | 1/1000 | |

PLAN 3

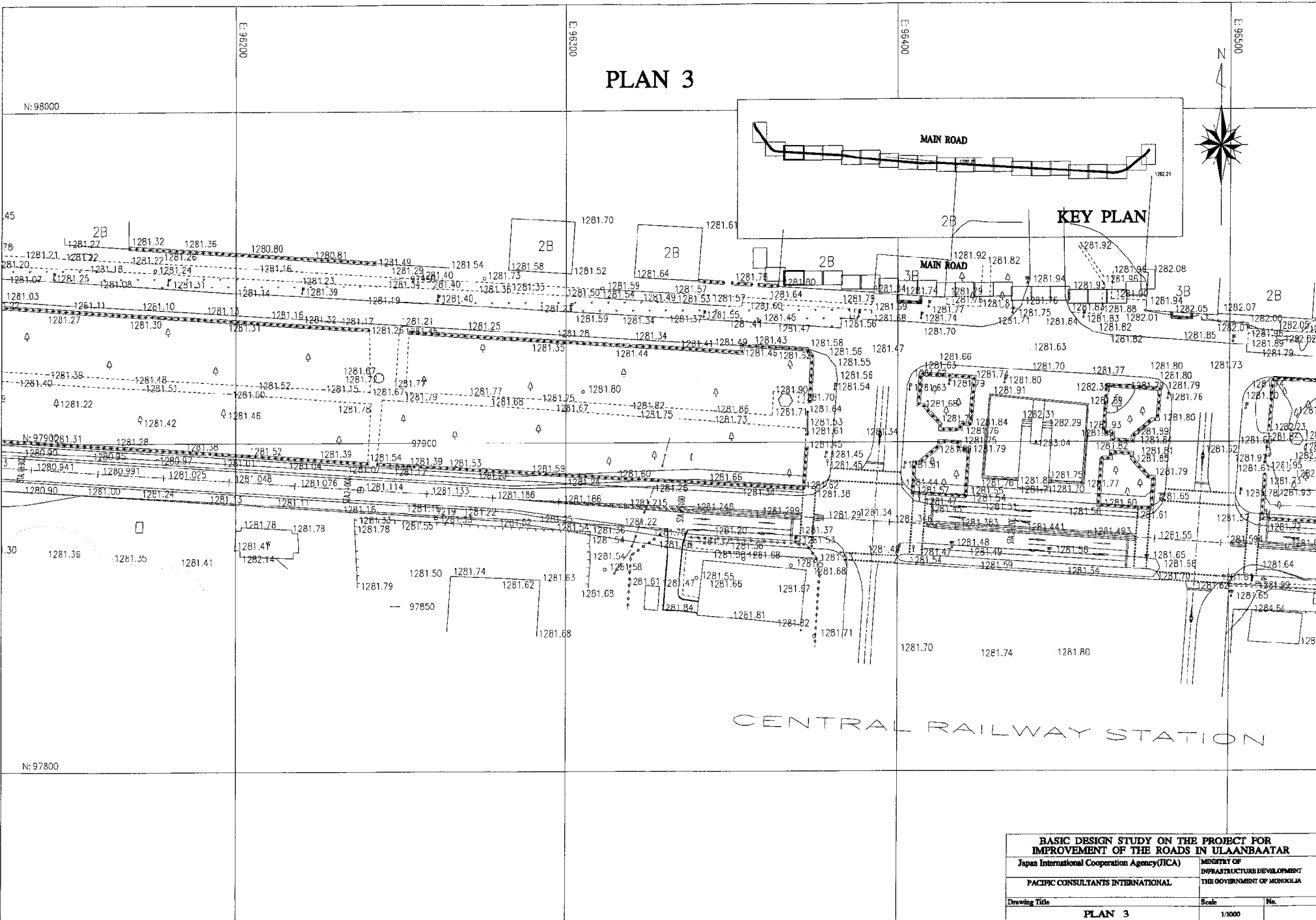
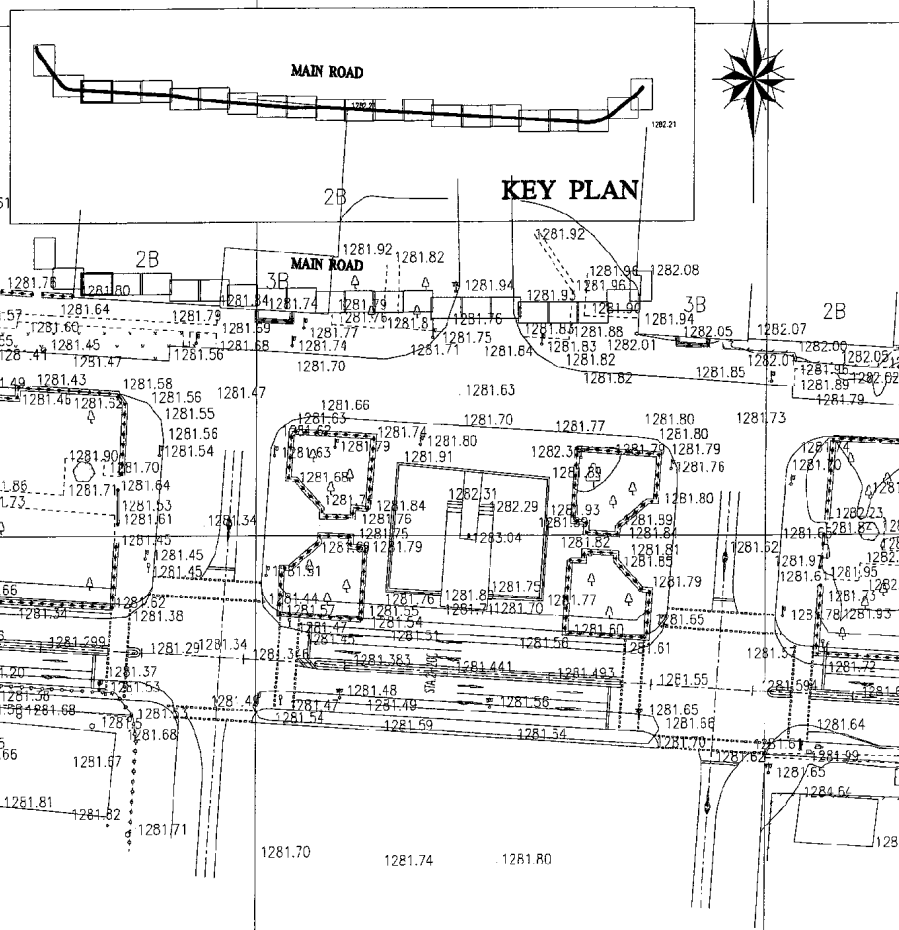

| | | |
|---|--|-----|
| BASIC DESIGN STUDY ON THE PROJECT FOR IMPROVEMENT OF THE ROADS IN ULAANBAATAR | | |
| Japan International Cooperation Agency (JICA) | MINISTRY OF INFRASTRUCTURE DEVELOPMENT | |
| PACIFIC CONSULTANTS INTERNATIONAL | THE GOVERNMENT OF MONGOLIA | |
| Drawing Title | Scale | No. |
| PLAN 3 | 1/1000 | |

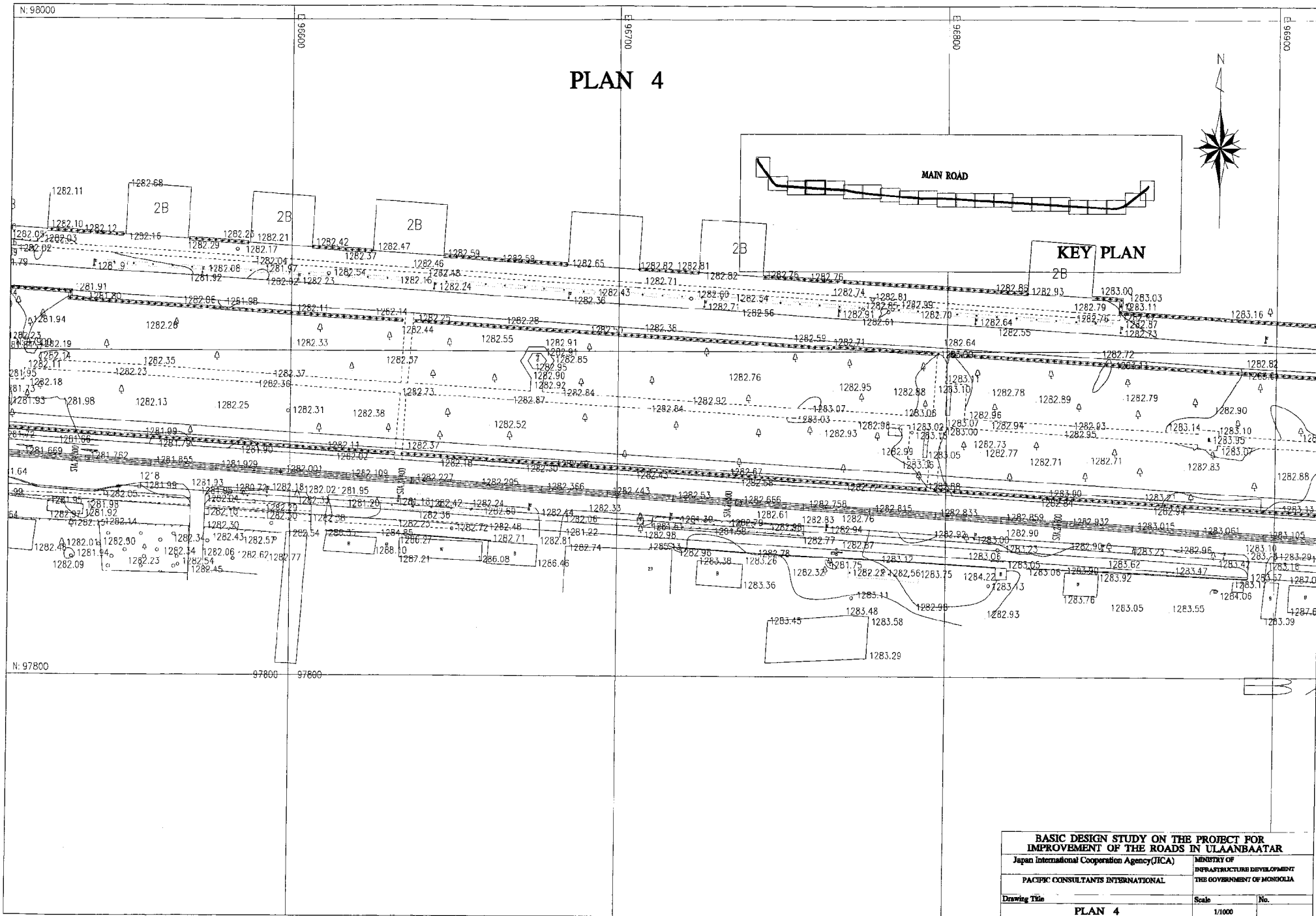

PLAN 4

| | | |
|--|--------|---|
| BASIC DESIGN STUDY ON THE PROJECT FOR IMPROVEMENT OF THE ROADS IN ULAANBAATAR | | |
| Japan International Cooperation Agency (JICA) | | MINISTRY OF INFRASTRUCTURE DEVELOPMENT THE GOVERNMENT OF MONGOLIA |
| PACIFIC CONSULTANTS INTERNATIONAL | | |
| Drawing Title | Scale | No. |
| PLAN 4 | 1/1000 | |

N: 98000

E: 97000

E: 97000

E: 97000

PLAN 5

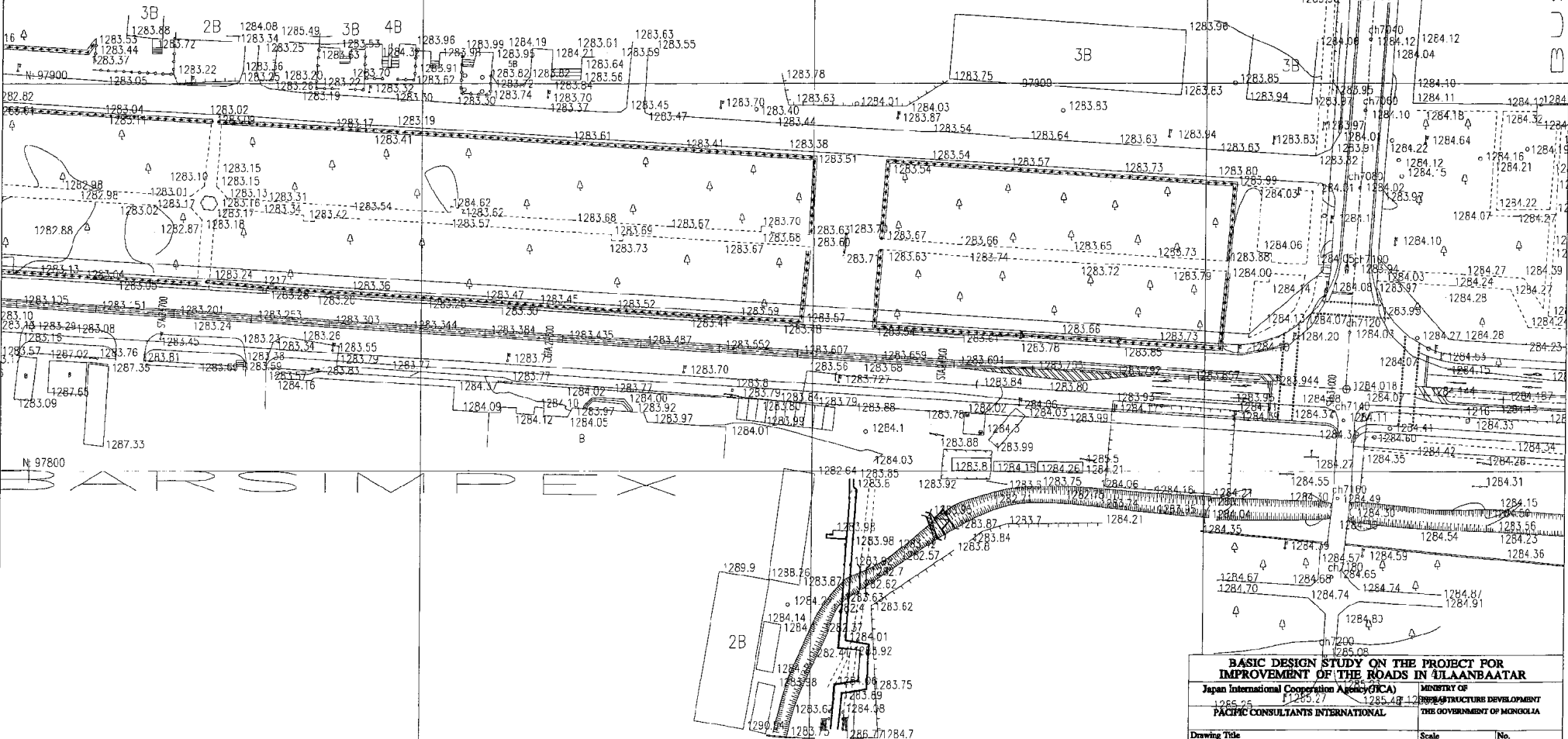
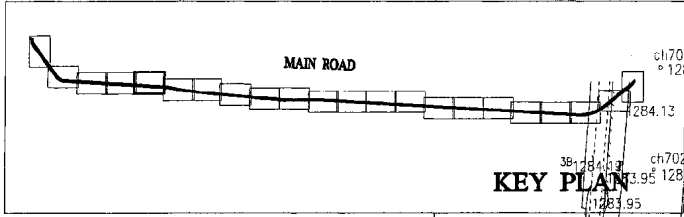

| | | |
|--|--|-----|
| BASIC DESIGN STUDY ON THE PROJECT FOR IMPROVEMENT OF THE ROADS IN ULAANBAATAR | | |
| Japan International Cooperation Agency (JICA) | MINISTRY OF INFRASTRUCTURE DEVELOPMENT | |
| PACIFIC CONSULTANTS INTERNATIONAL | THE GOVERNMENT OF MONGOLIA | |
| Drawing Title | Scale | No. |
| PLAN 5 | 1/1000 | |

PLAN 6

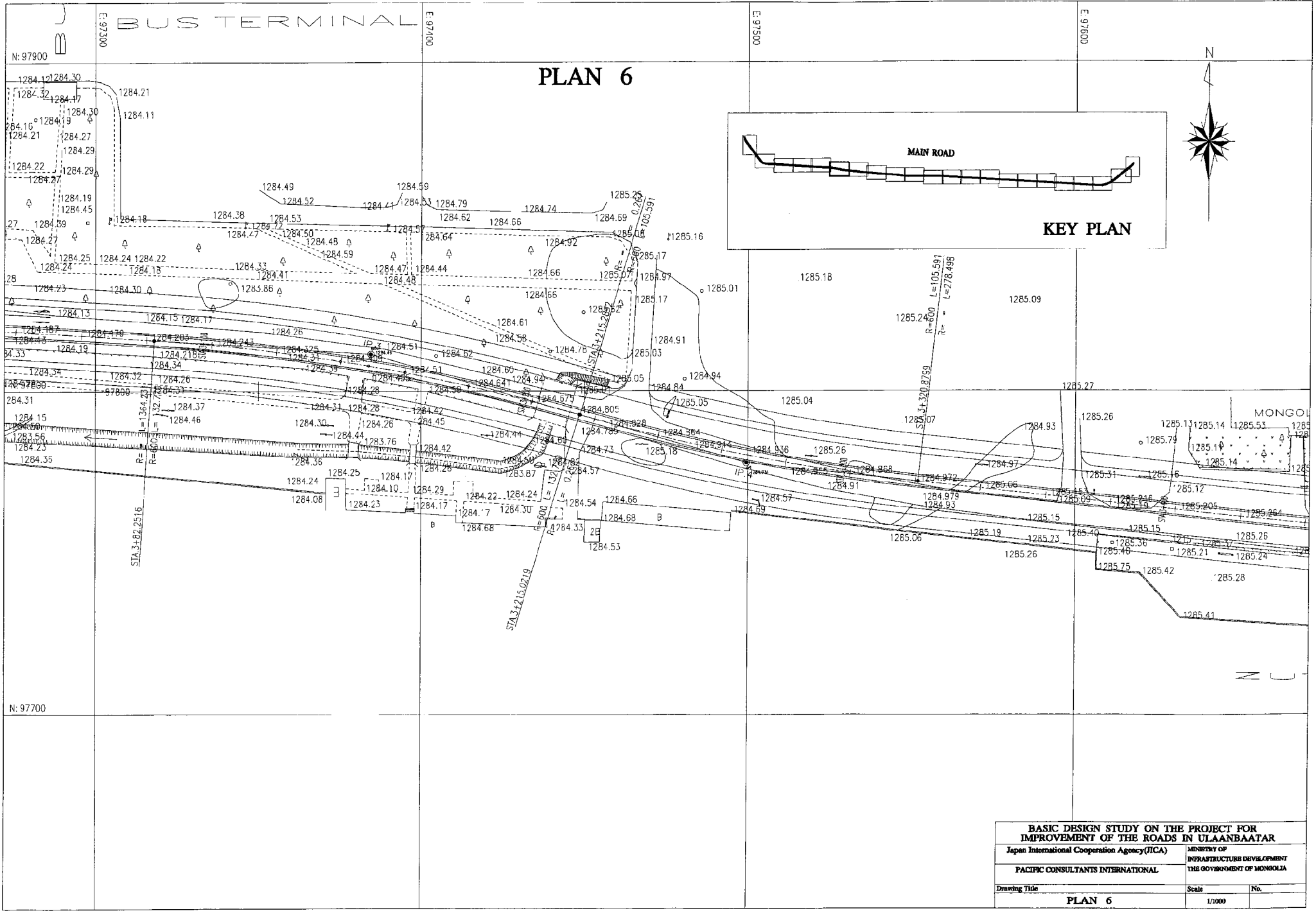
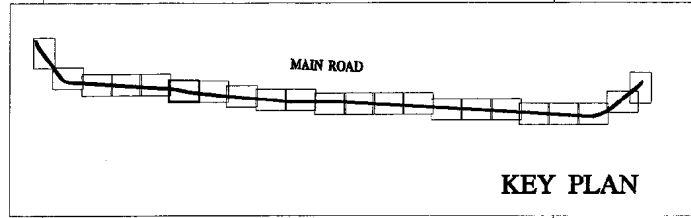

| | | |
|--|--------|---|
| BASIC DESIGN STUDY ON THE PROJECT FOR IMPROVEMENT OF THE ROADS IN ULAANBAATAR | | |
| Japan International Cooperation Agency (JICA) | | MINISTRY OF INFRASTRUCTURE DEVELOPMENT THE GOVERNMENT OF MONGOLIA |
| PACIFIC CONSULTANTS INTERNATIONAL | | |
| Drawing Title | Scale | No. |
| PLAN 6 | 1/1000 | |