

Appendix 5 Basic Design Drawings

List of Basic Design Drawings

No.	Title
1.	General Plan of Pipelines, Jenin Area
2.	General Plan of Pipelines, Burqa Area
3.	General Plan of Pipelines, Hiwara Area
4.	General Plan of Pipelines, Attil Area
5.	General Plan of Pipelines, Kaffin Area
6.	General Plan of Pipelines, Baqa Al Sharkya Area
7.	General Plan of Pipelines, Rantis Area
8.	Reservoir Tank, Hiwara Area
9.	Reservoir Tank, Attil Area
10.	Reservoir Tank, Baqa Al Sharkya Area
11.	Reservoir Tank, Rantis Area
12.	Structural Details of Reservoir Tank, Elevated Type, 200m ³
13.	Structural Details of Reservoir Tank, Elevated Type, 300m ³
14.	Structural Details of Reservoir Tank, Elevated Type, 500m ³
15.	Structural Details of Reservoir Tank, On-ground Type, 500m ³
16.	Booster Pump Station, Pump House Plan
17.	Booster Pump Station, General Plan
18.	Standard Section of Pipelines, Siphon, Pipe Protection Work
19.	Valve Chamber (1/2)
20.	Valve Chamber (2/2)
21.	House Connection and Others

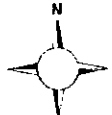

LEGEND

Water Source (Existing Well)	
Existing Water Tank	
Existing Transmission Pipe	
Existing Distribution Pipe (φ 250)	
Existing Distribution Pipe (φ 200)	
Existing Distribution Pipe (φ 150)	
Proposed Distribution Pipe (φ 150)	
Proposed Distribution Pipe (φ 100)	
Proposed Distribution Pipe (φ 75)	
Proposed Distribution Pipe (φ 50)	

To be Replaced

Electric Line
Telephone Line

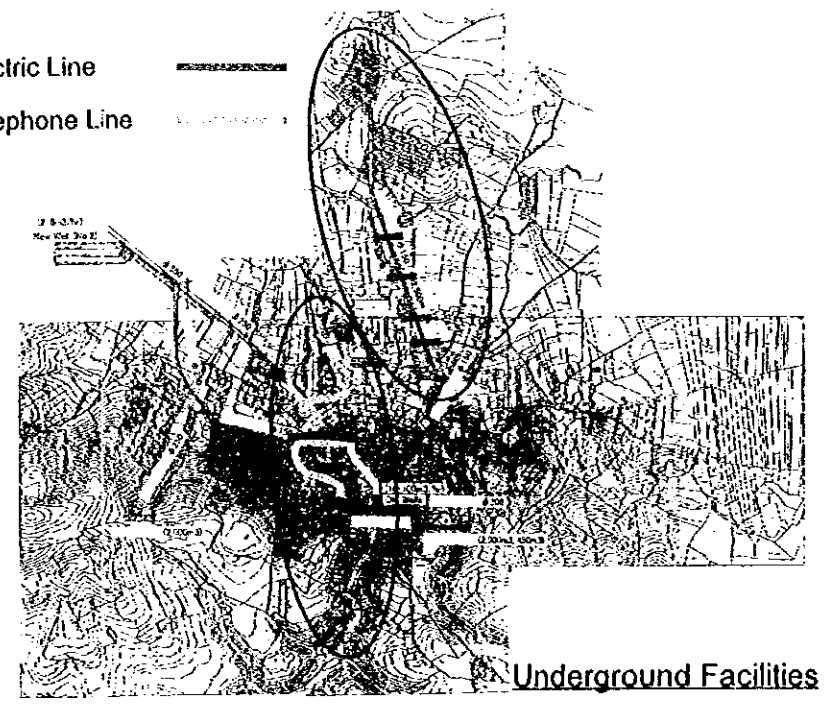

New Well
(17-20/051J)
(210 m³/hr)

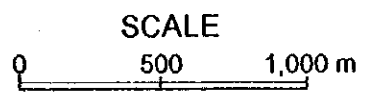
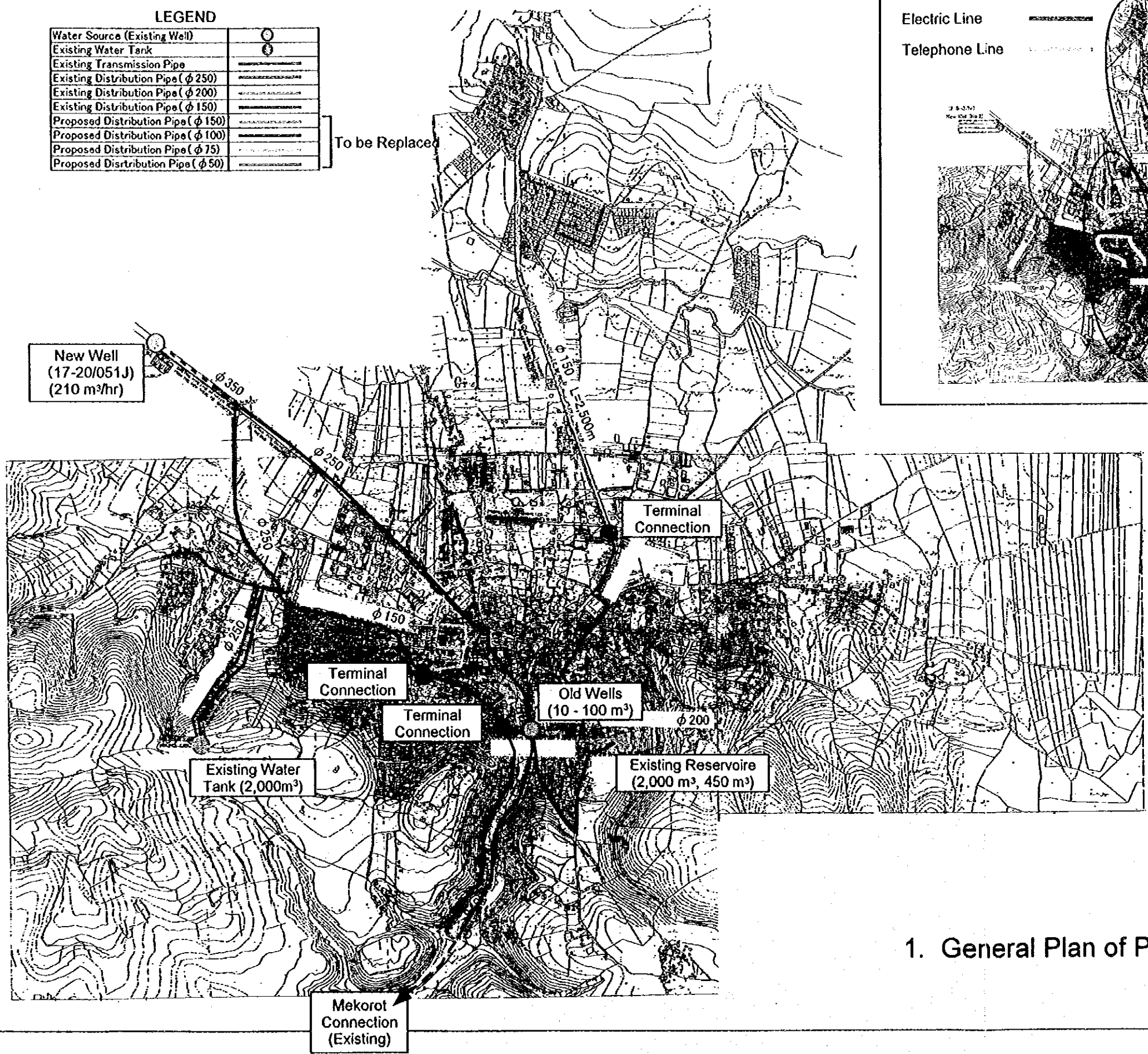

1. General Plan of Pipelines, Jenin Area

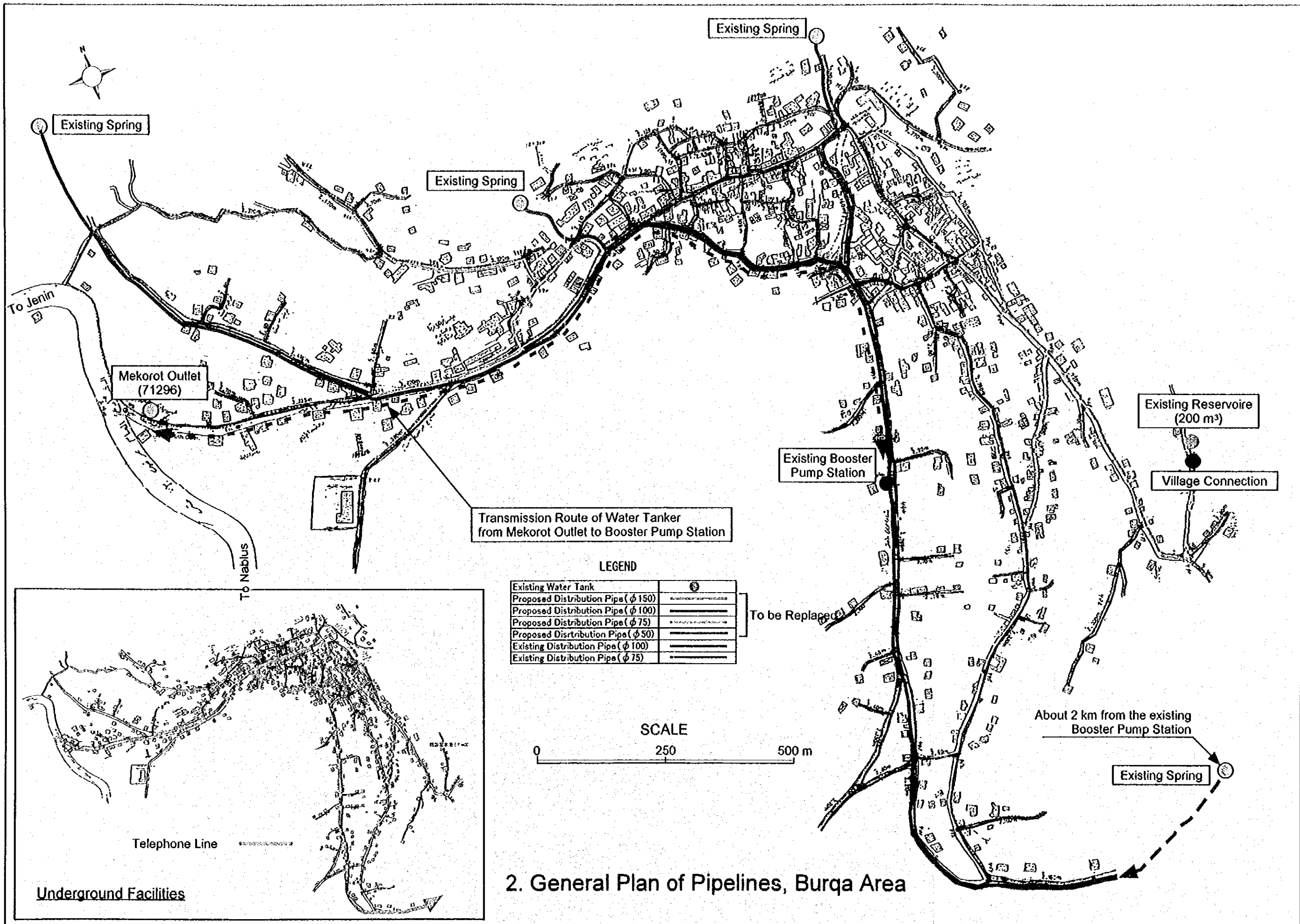

Transmission Route of Water Tanker
from Mekorot Outlet to Booster Pump Station

LEGEND

Existing Water Tank	
Proposed Distribution Pipe (φ 150)	
Proposed Distribution Pipe (φ 100)	
Proposed Distribution Pipe (φ 75)	
Proposed Distribution Pipe (φ 50)	
Existing Distribution Pipe (φ 100)	
Existing Distribution Pipe (φ 75)	

To be Replaced

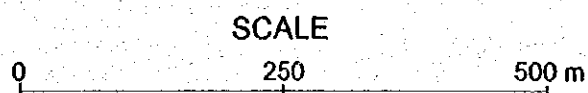

2. General Plan of Pipelines, Burqa Area

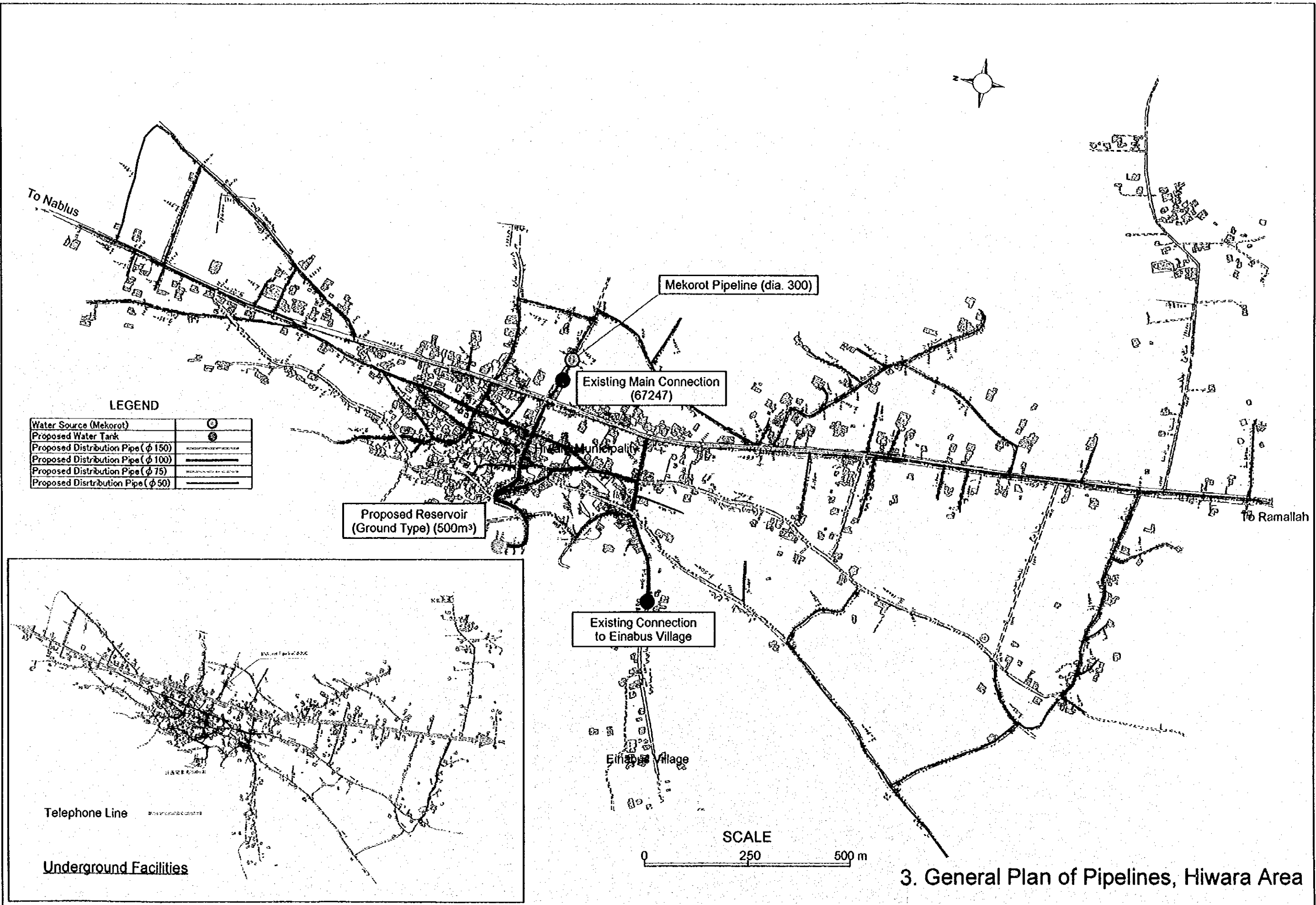

3. General Plan of Pipelines, Hiwara Area

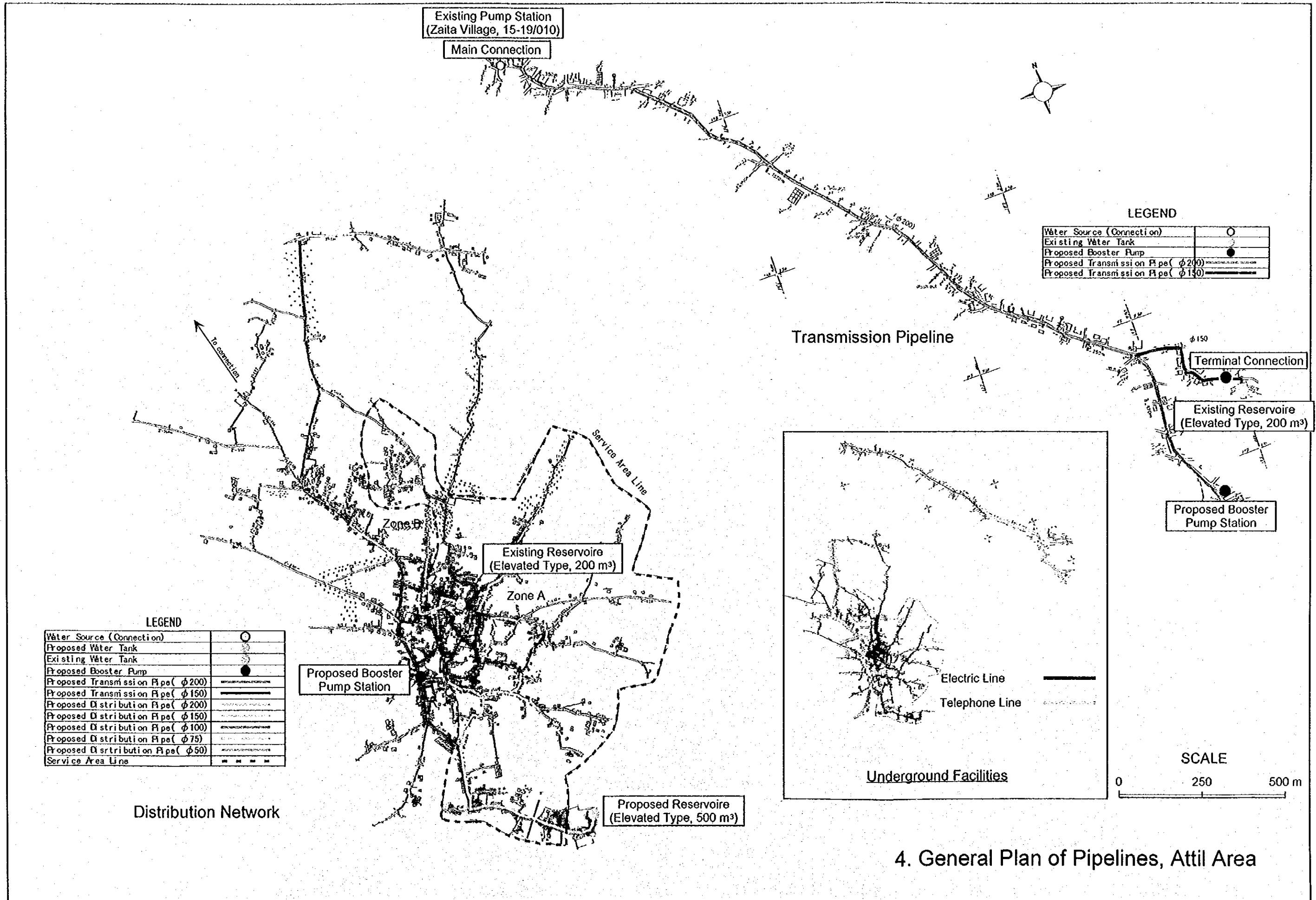

Existing Pump Station
(Zaita Village, 15-19/010)

Main Connection

LEGEND

Water Source (Connection)	○
Existing Water Tank	○
Proposed Booster Pump	●
Proposed Transmission Pipe (φ200)	—
Proposed Transmission Pipe (φ150)	—

Transmission Pipeline

Terminal Connection

Existing Reservoir
(Elevated Type, 200 m³)

Proposed Booster
Pump Station

LEGEND

Water Source (Connection)	○
Proposed Water Tank	○
Existing Water Tank	○
Proposed Booster Pump	●
Proposed Transmission Pipe (φ200)	—
Proposed Transmission Pipe (φ150)	—
Proposed Distribution Pipe (φ200)	—
Proposed Distribution Pipe (φ150)	—
Proposed Distribution Pipe (φ100)	—
Proposed Distribution Pipe (φ75)	—
Proposed Distribution Pipe (φ50)	—
Service Area Line	- - - -

Proposed Booster
Pump Station

Existing Reservoir
(Elevated Type, 200 m³)

Zone B

Zone A

Proposed Reservoir
(Elevated Type, 500 m³)

Distribution Network

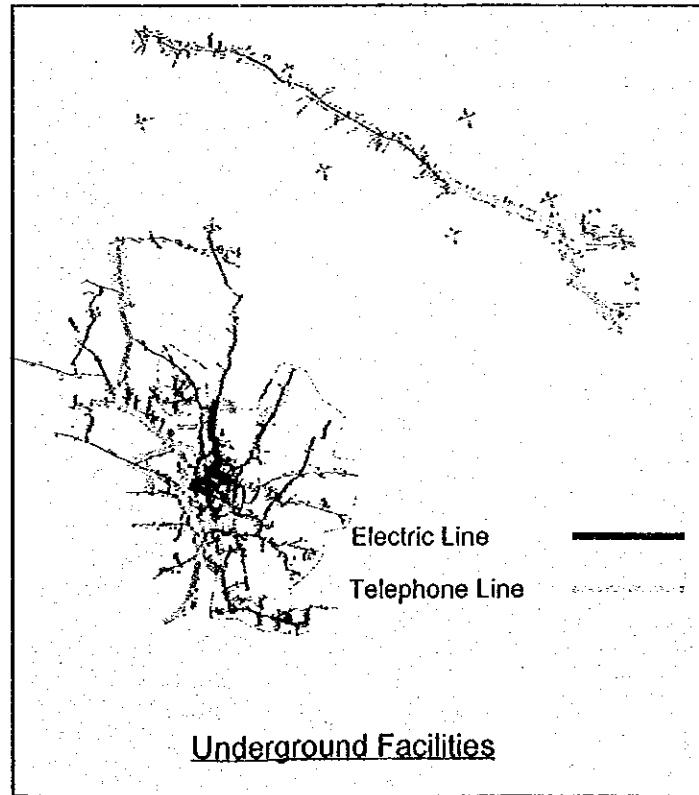

Underground Facilities

Electric Line
Telephone Line

SCALE

0 250 500 m

4. General Plan of Pipelines, Attil Area

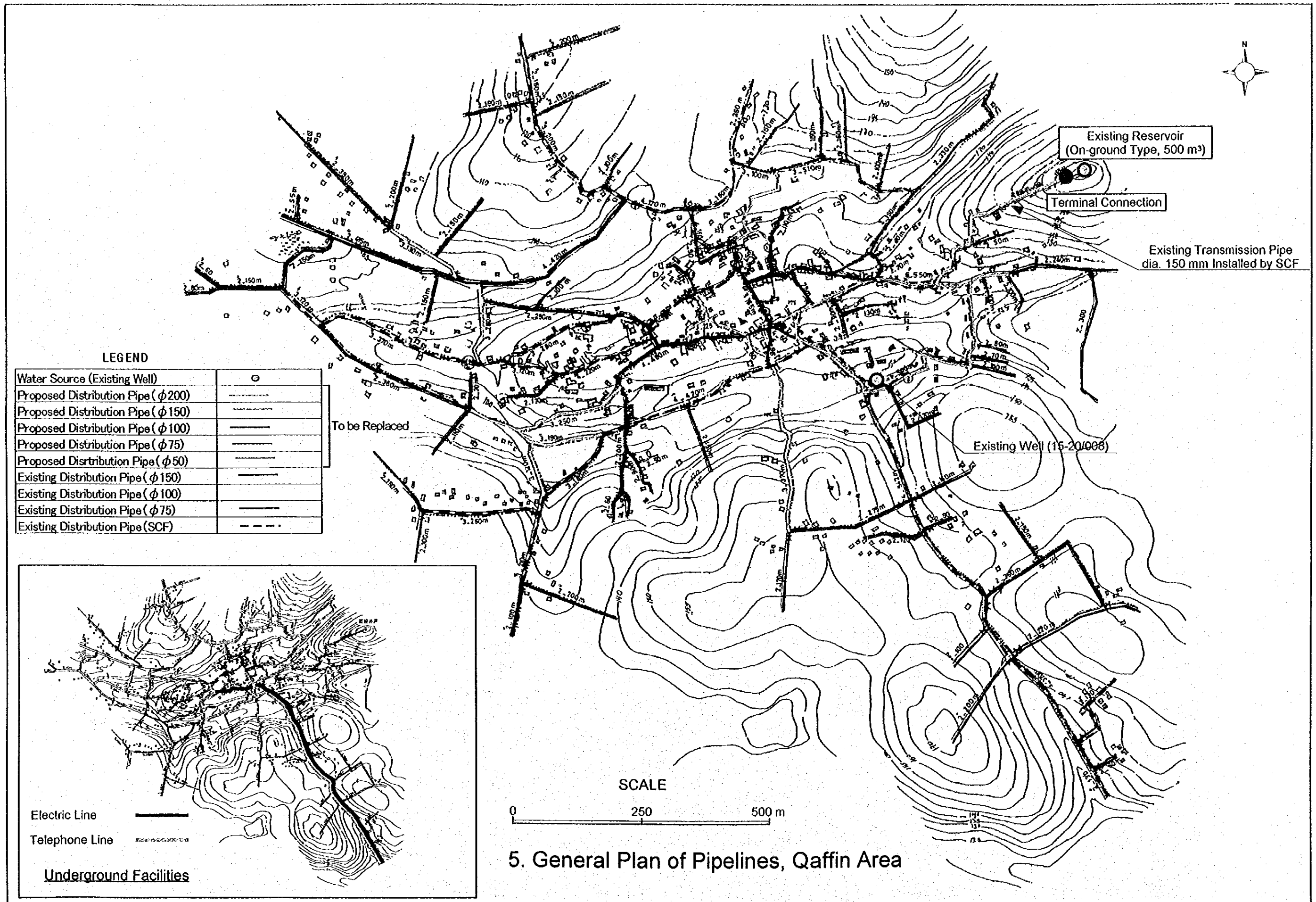

LEGEND

Water Source (Existing Well)	○
Proposed Distribution Pipe (φ 200)	-----
Proposed Distribution Pipe (φ 150)	- - - - -
Proposed Distribution Pipe (φ 100)	—————
Proposed Distribution Pipe (φ 75)	—————
Proposed Distribution Pipe (φ 50)	—————
Existing Distribution Pipe (φ 150)	—————
Existing Distribution Pipe (φ 100)	—————
Existing Distribution Pipe (φ 75)	—————
Existing Distribution Pipe (SCF)	- - - - -

To be Replaced

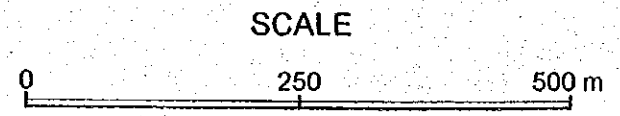
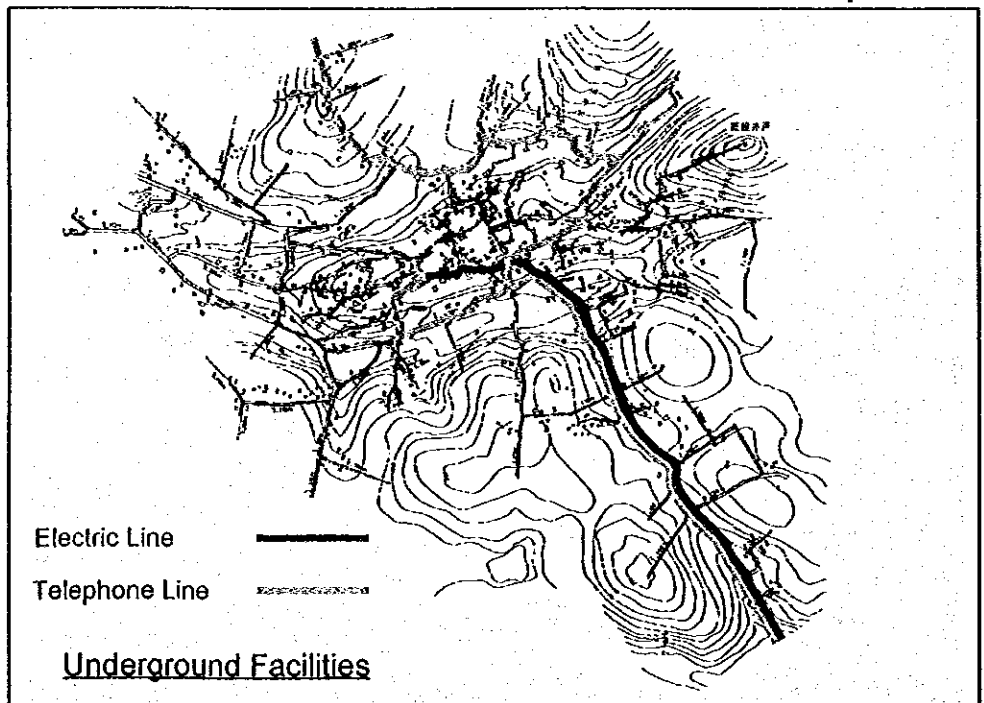

5. General Plan of Pipelines, Qaffin Area

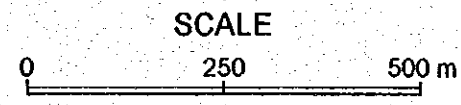
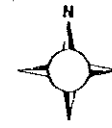
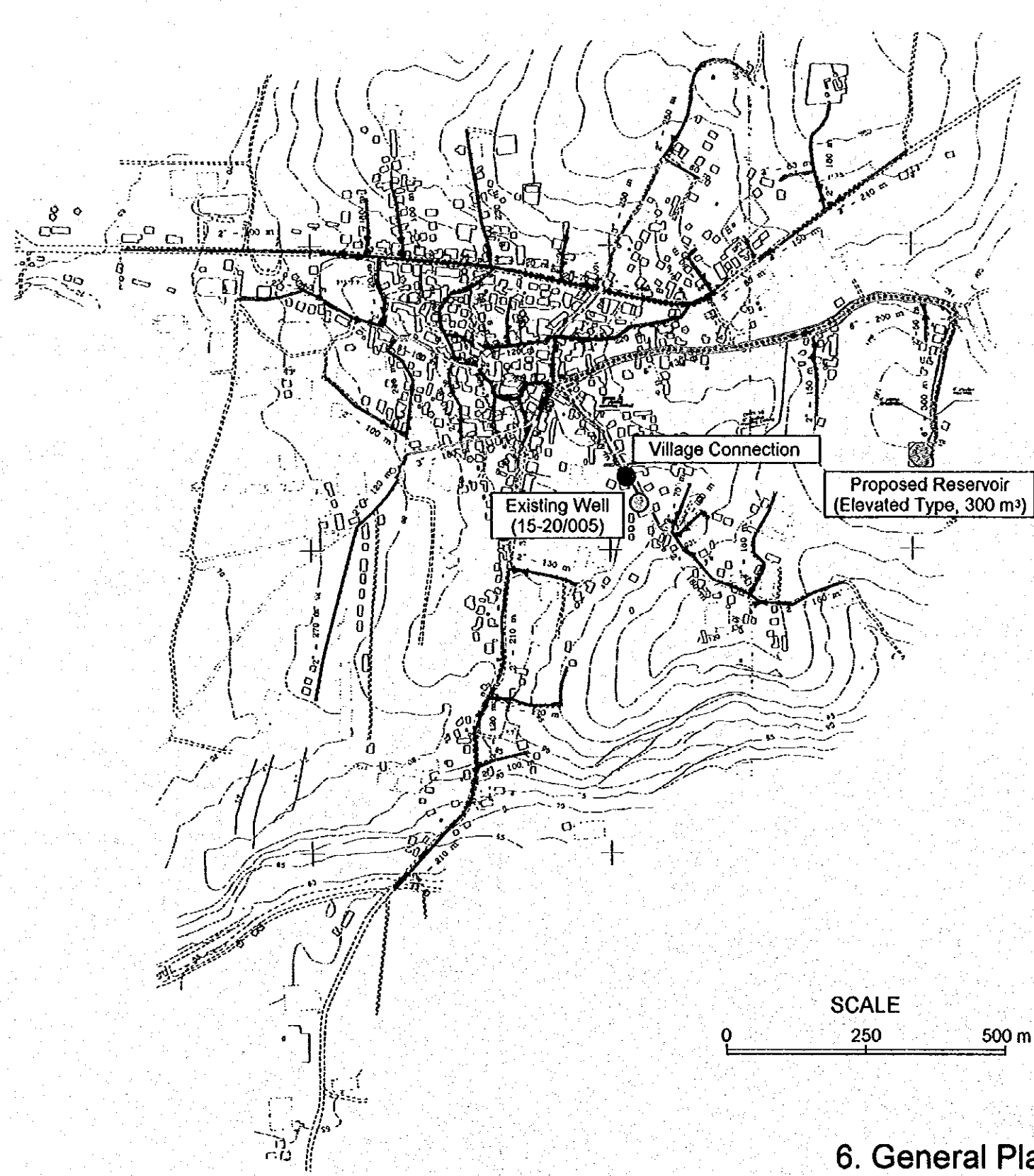

LEGEND

Water Source (Existing Well)	
Proposed Water Tank	
Proposed Transmission Pipe (φ 150)	
Proposed Distribution Pipe (φ 150)	
Proposed Distribution Pipe (φ 100)	
Proposed Distribution Pipe (φ 75)	
Proposed Distribution Pipe (φ 50)	

6. General Plan of Pipelines, Baqa Al Sharkiya Area

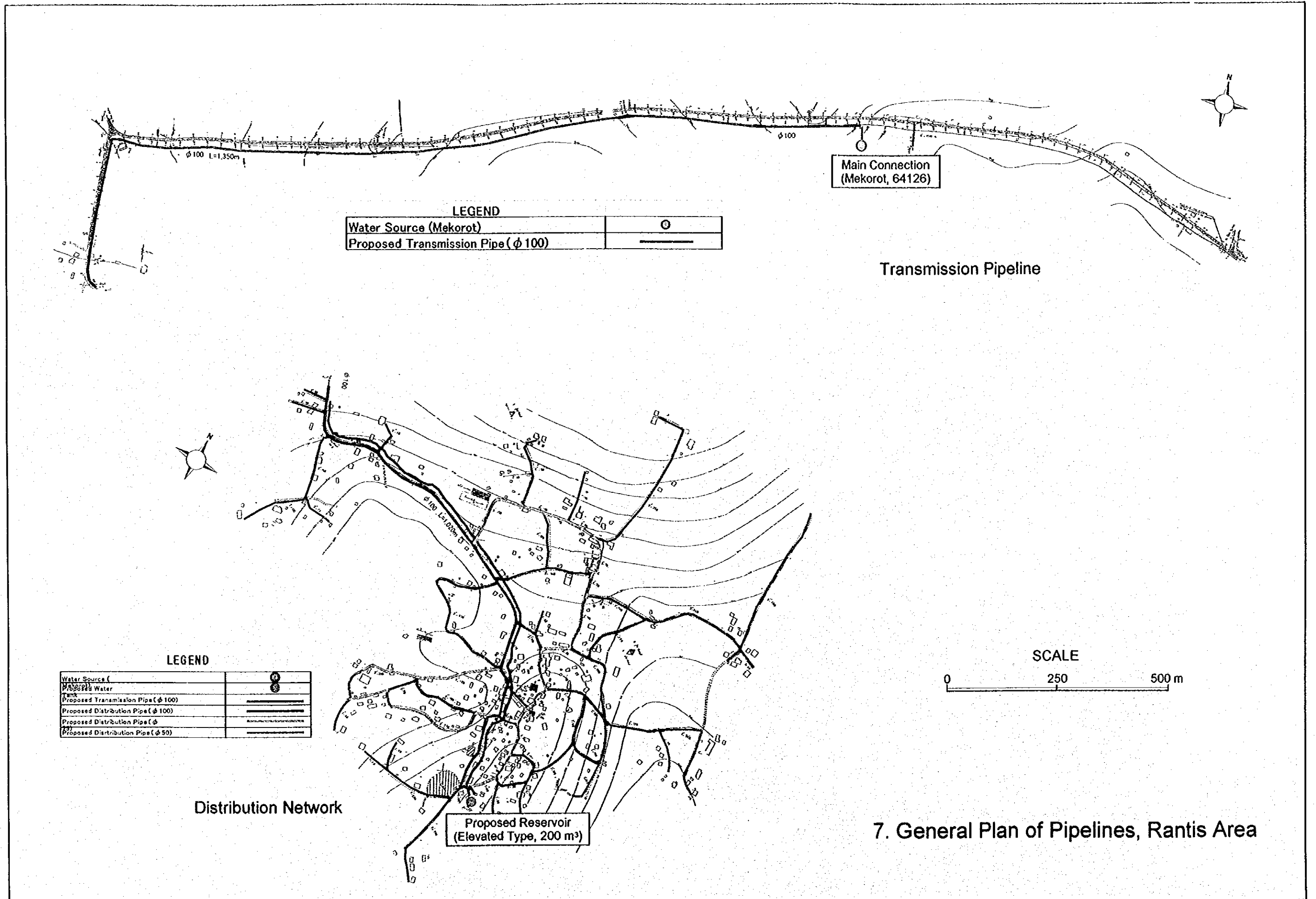

LEGEND

Water Source (Mekorot)	⊙
Proposed Transmission Pipe (φ 100)	—

Main Connection
(Mekorot, 64126)

Transmission Pipeline

LEGEND

Water Source	⊙
Tank	⊙
Proposed Transmission Pipe (φ 100)	—
Proposed Distribution Pipe (φ 100)	—
Proposed Distribution Pipe (φ 50)	—

Proposed Reservoir
(Elevated Type, 200 m³)

Distribution Network

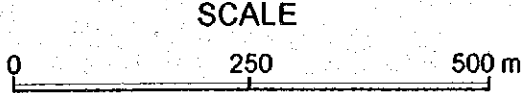

7. General Plan of Pipelines, Rantis Area

ATTIL WATER RESERVOIR

PLAN S=1:200

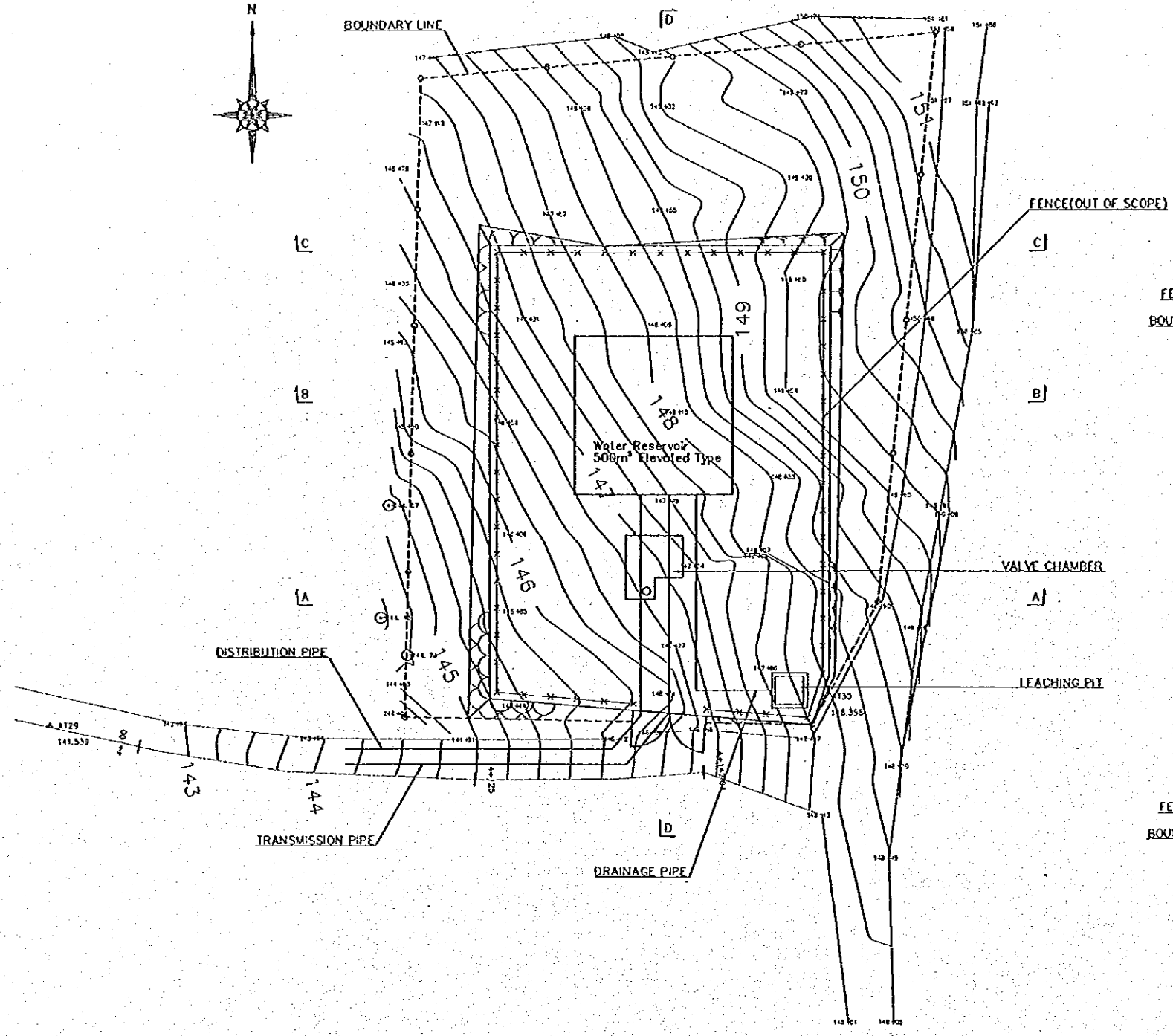

SECTION A-A

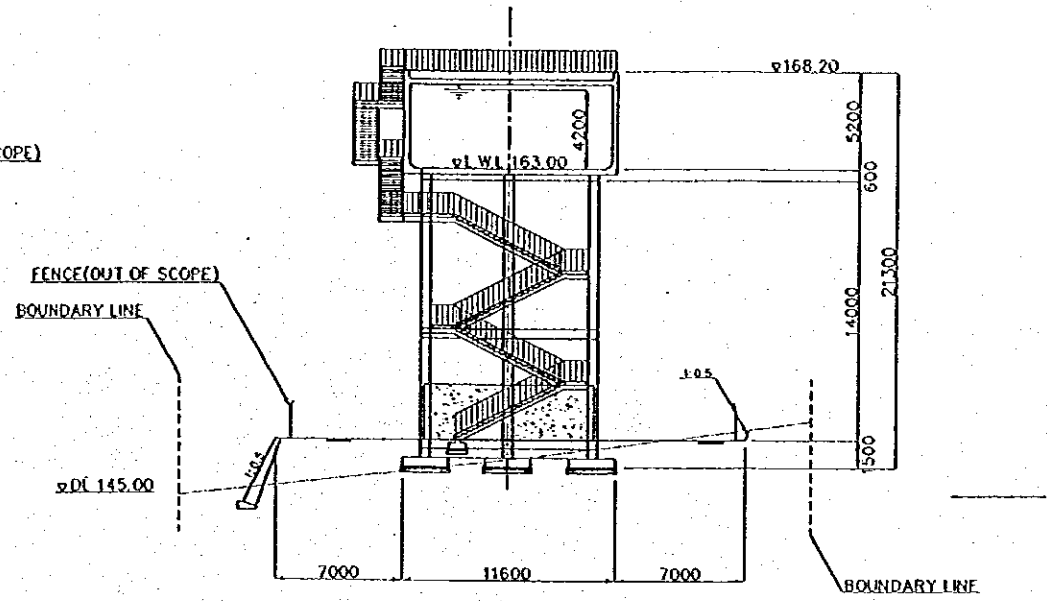

SECTION B-B

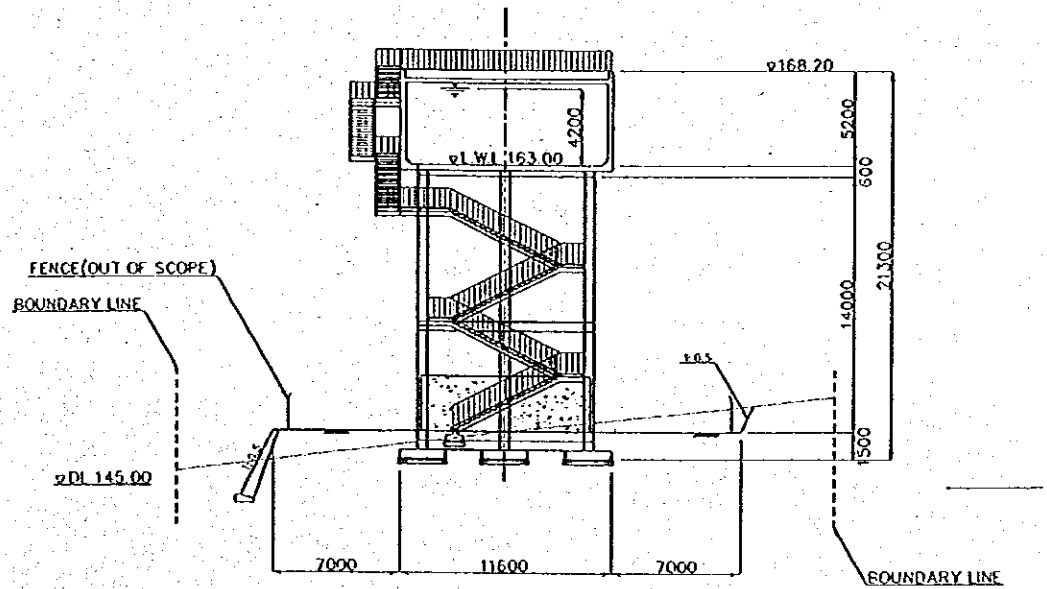

SECTION D-D

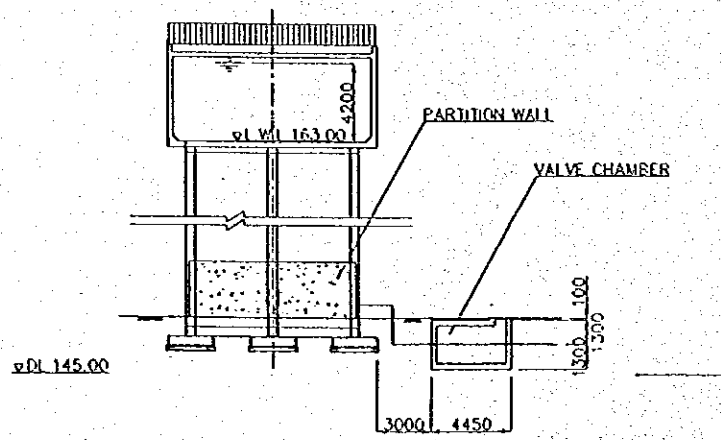

SECTION C-C

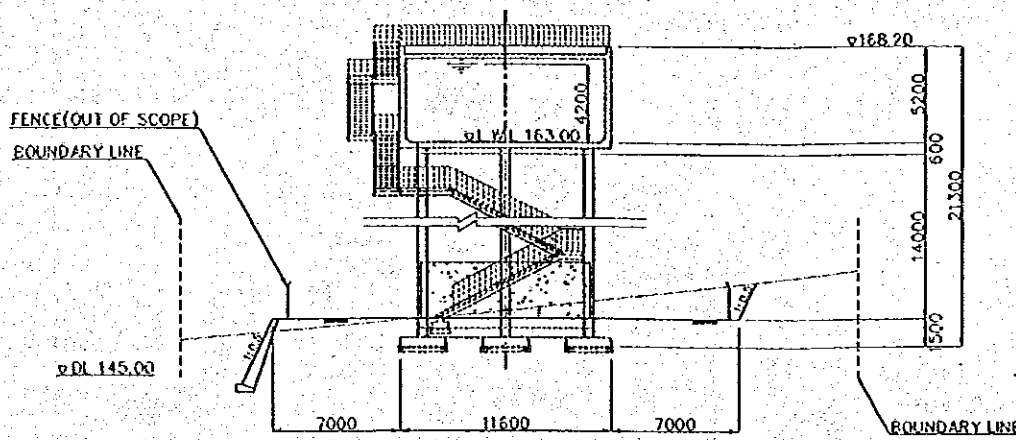

8. Reservoir Tank, Attil Area

THE PROJECT FOR IMPROVEMENT OF WATER DISTRIBUTION FACILITIES IN THE NORTHERN DISTRICTS OF THE WEST BANK, PHASE-2			
TITLE			
ATTIL WATER RESERVOIR			
PACIFIC CONSULTANTS INTERNATIONAL			DRG. NO.
DESIGNED BY:	APPROVED BY:		A1-001
VERIFIED BY:			
DATE:	SCALE:	1:200	
THE PALESTINIAN WATER AUTHORITY, PA			

BAQA AL SHARQIYA WATER RESERVOIR

PLAN Scale: 1:200

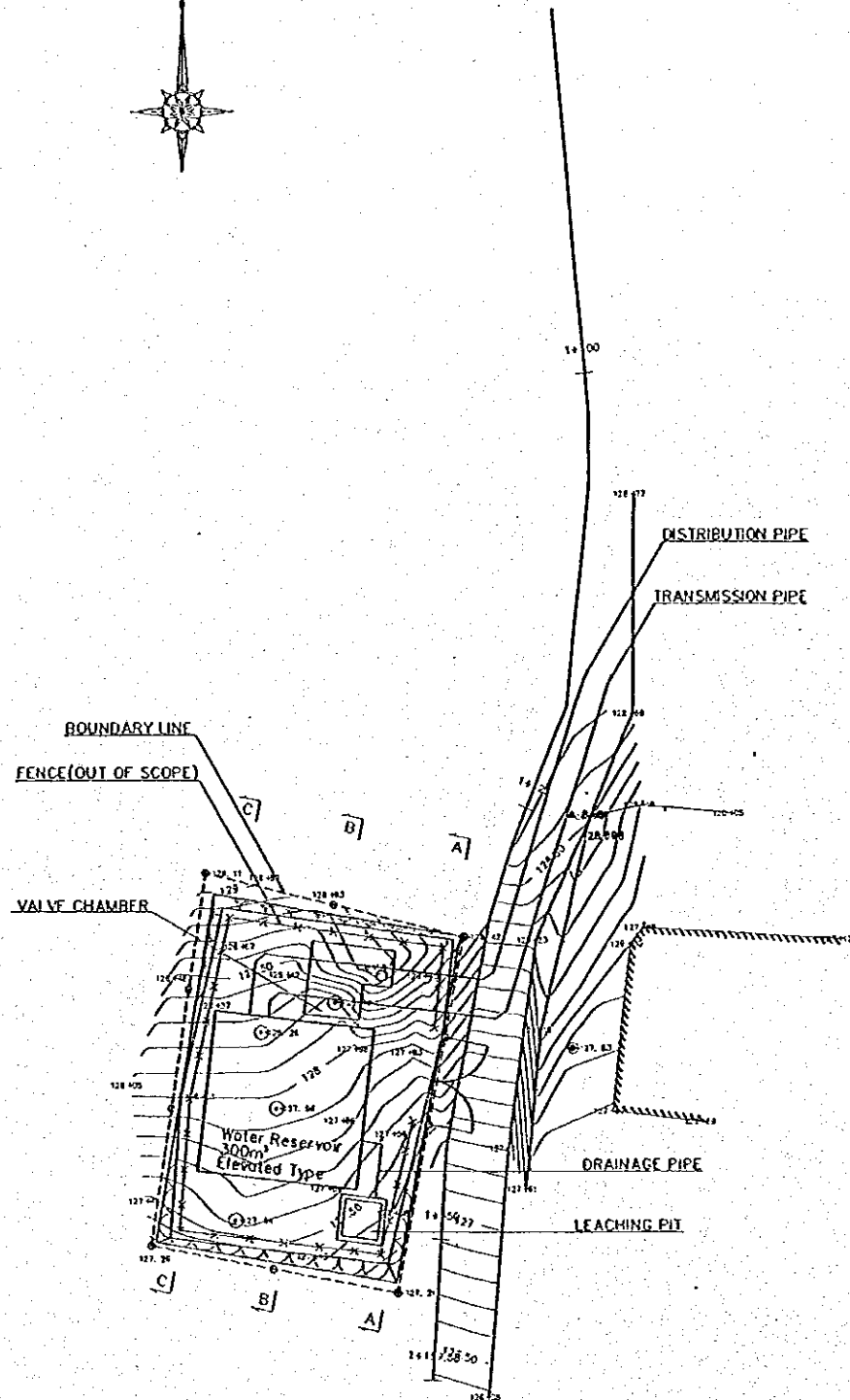
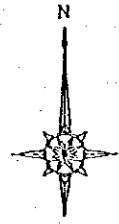

SECTION A-A

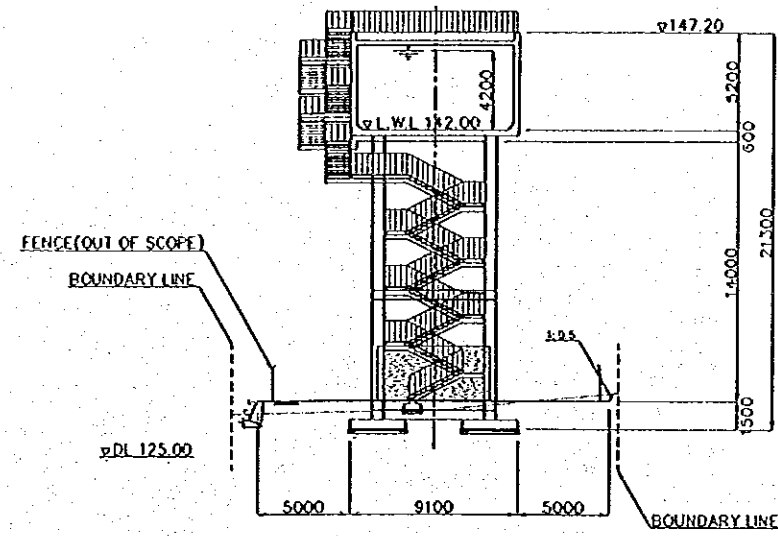

SECTION C-C

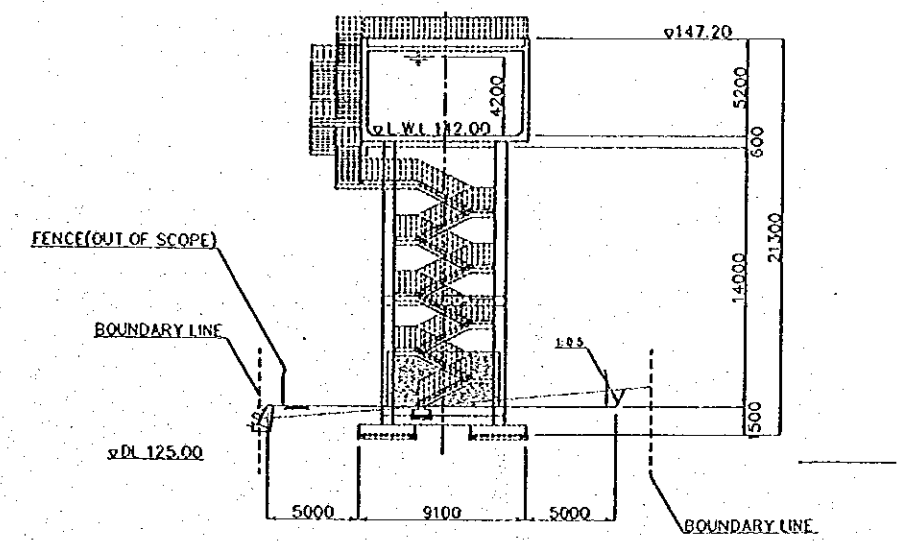

SECTION B-B

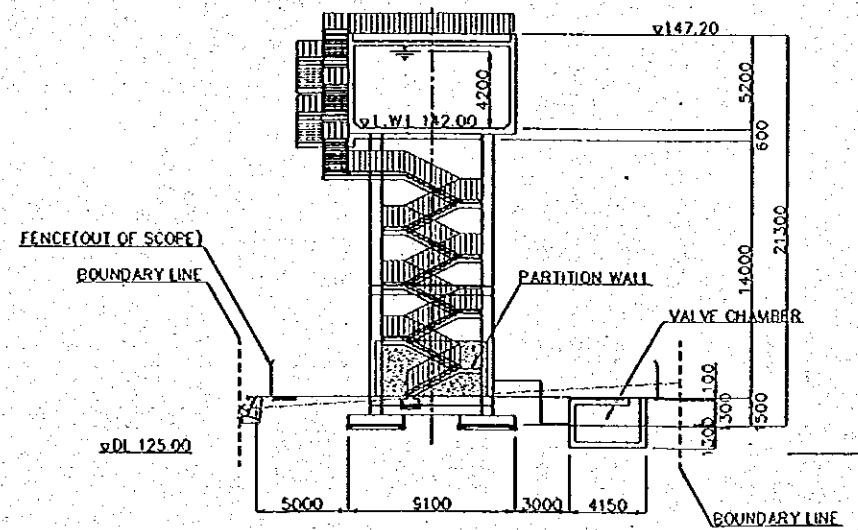

9. Reservoir Tank, Baqa Al Sharkiya Area

THE PROJECT FOR IMPROVEMENT OF WATER DISTRIBUTION FACILITIES IN THE NORTHERN DISTRICTS OF THE WEST BANK, PHASE-2			
TITLE			
BAQA AL SHARQIYA WATER RESERVOIR			
PACIFIC CONSULTANTS INTERNATIONAL			DWG. NO.
DESIGNED BY:	APPROVED BY:		Bq-001
VERIFIED BY:			
DATE:	SCALE:	1:200	
THE PALESTINIAN WATER AUTHORITY, PA			

HIWARA WATER RESERVOIR

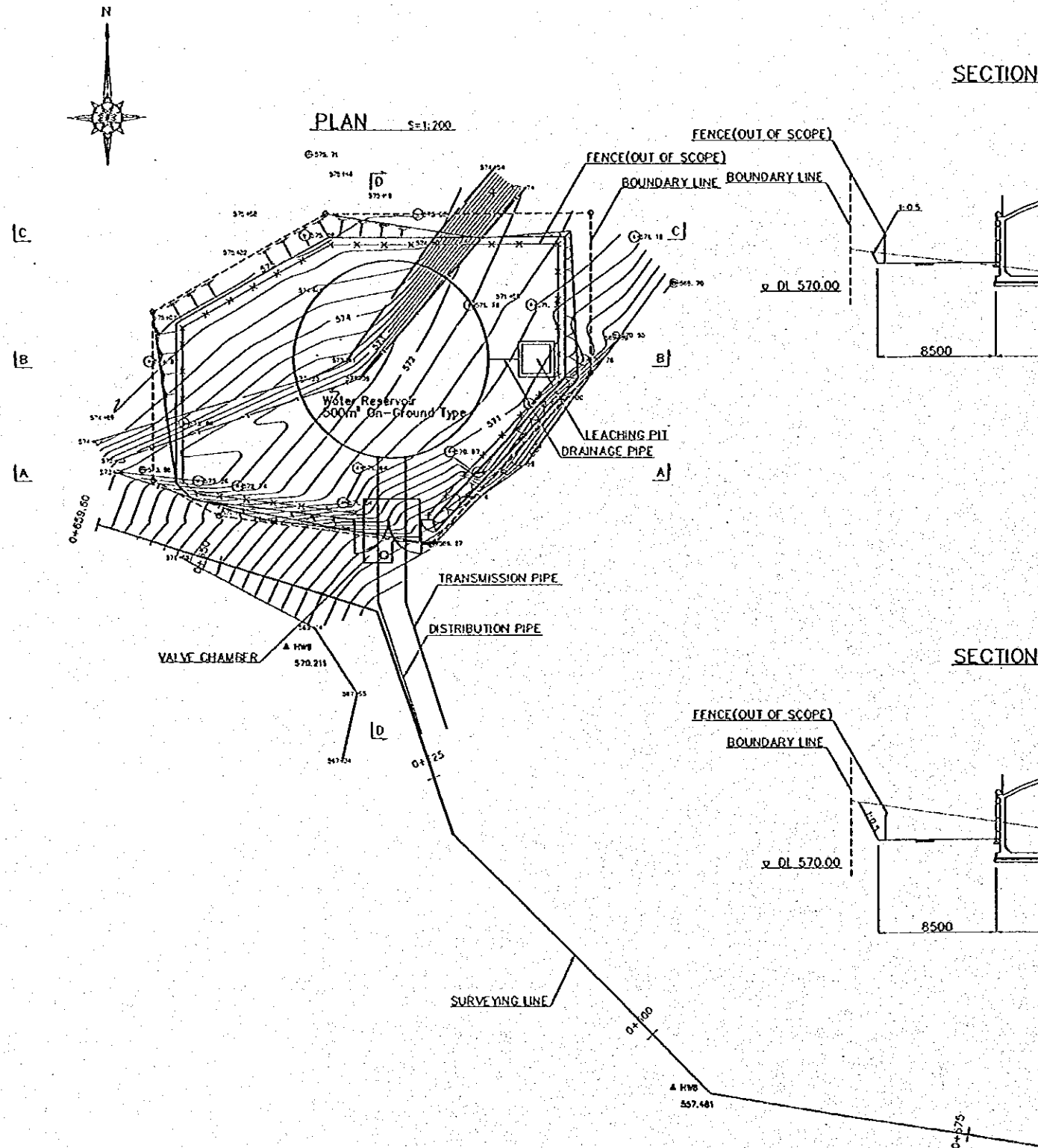

SECTION A-A

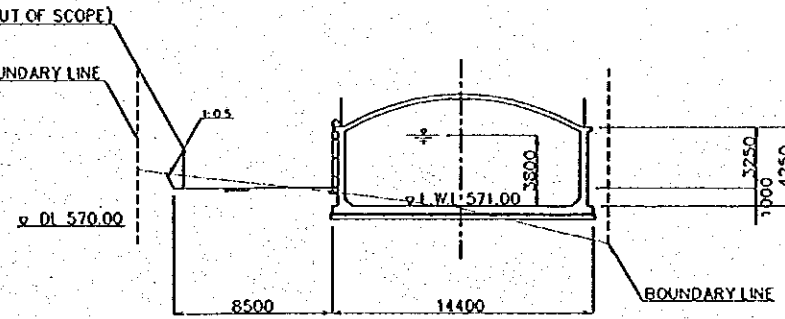

SECTION C-C

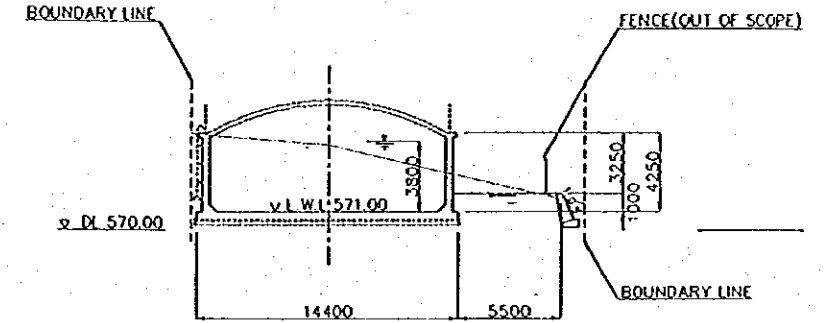

SECTION B-B

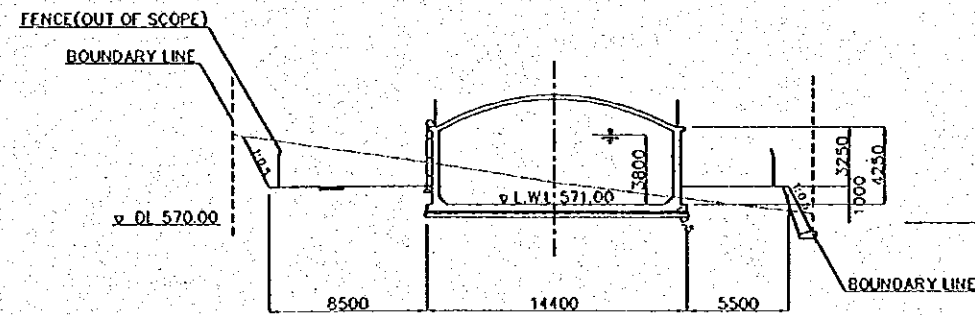

SECTION D-D

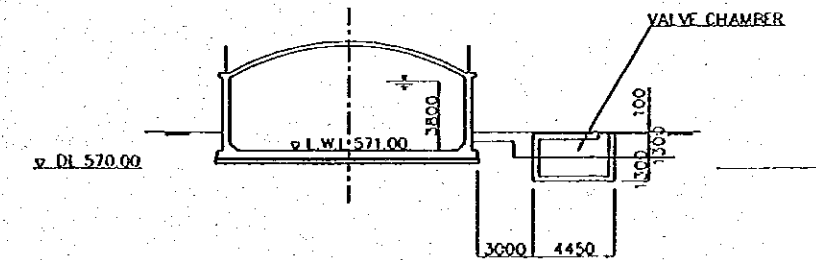

10. Reservoir Tank, Hiwara Area

THE PROJECT FOR IMPROVEMENT OF WATER DISTRIBUTION FACILITIES IN THE NORTHERN DISTRICTS OF THE WEST BANK, PHASE-2			
TITLE			
HIWARA WATER RESERVOIR			
PACIFIC CONSULTANTS INTERNATIONAL			DWG. NO.
DESIGNED BY:	APPROVED BY:		HI-001
VERIFIED BY:			
DATE:	SCALE:	1:200	
THE PALESTINIAN WATER AUTHORITY, PA			

RANTIS WATER RESERVOIR

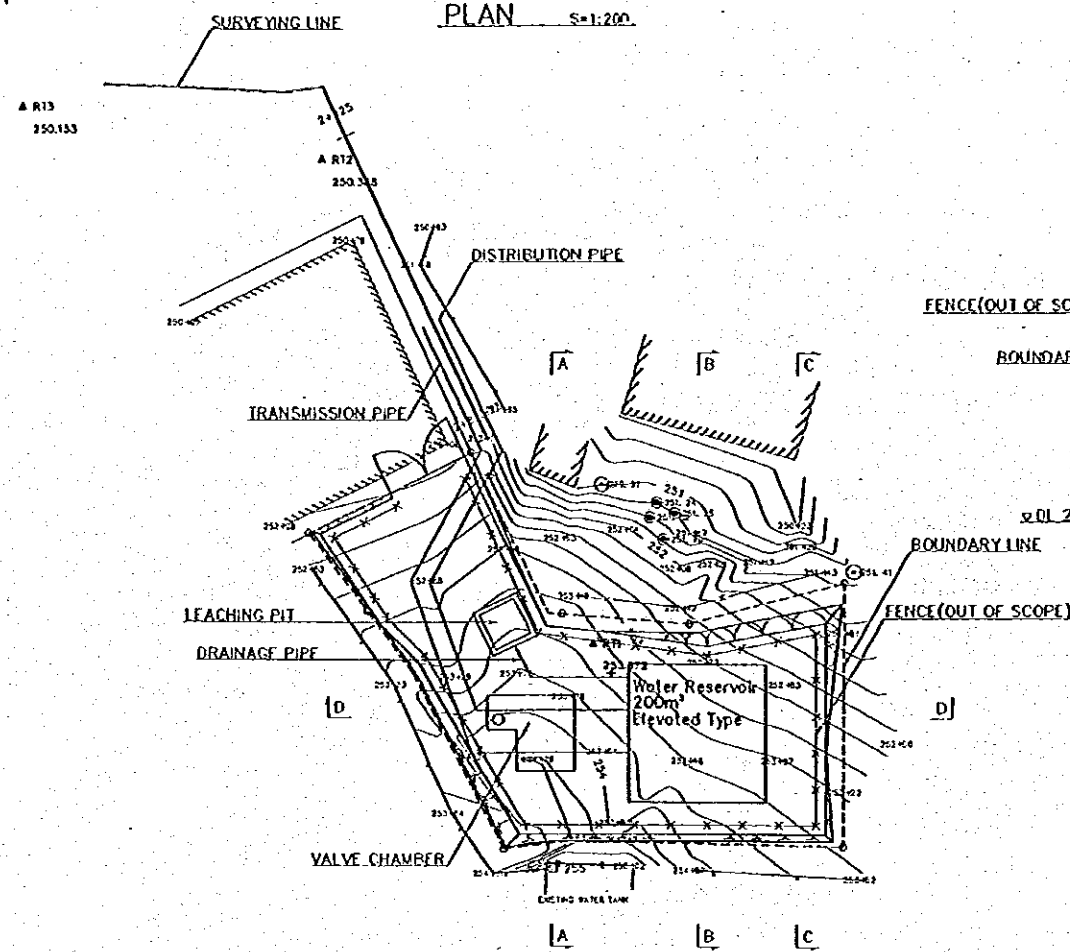
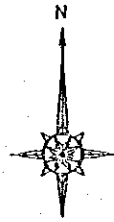

SECTION A-A

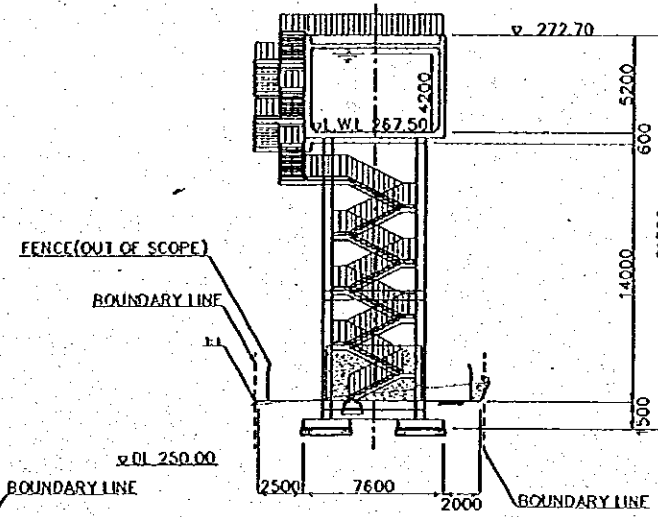

SECTION C-C

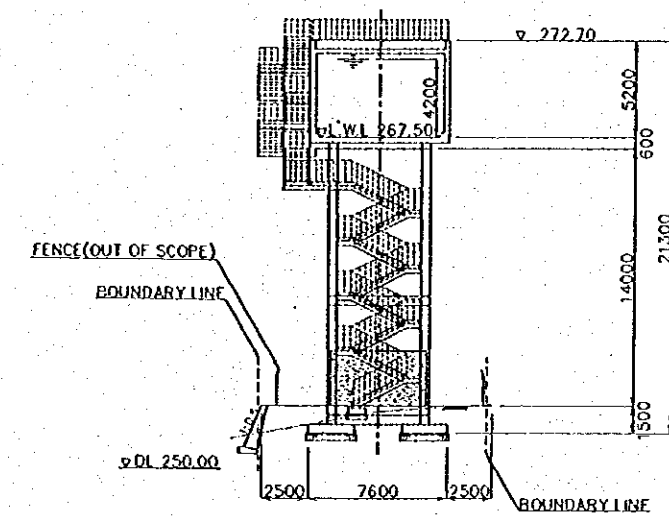

SECTION B-B

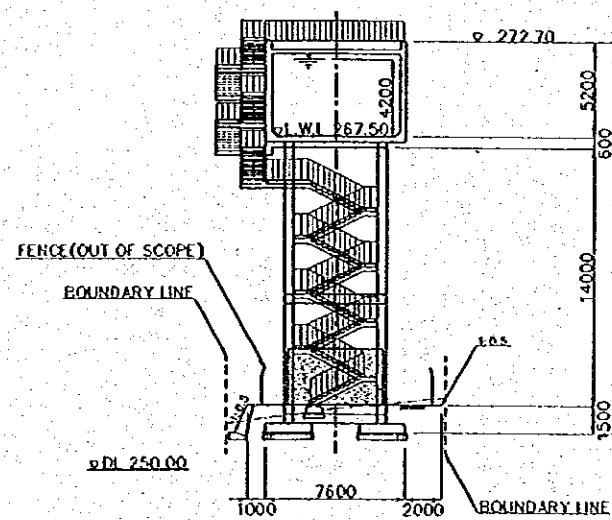

SECTION D-D

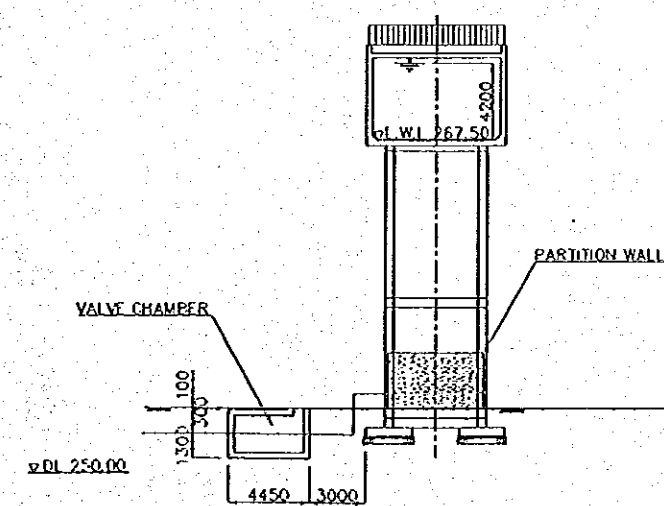

11. Reservoir Tank, Rantis Area

THE PROJECT FOR IMPROVEMENT OF WATER DISTRIBUTION FACILITIES IN THE NORTHERN DISTRICTS OF THE WEST BANK, PHASE-2			
TITLE			
RANTIS WATER RESERVOIR			
PACIFIC CONSULTANTS INTERNATIONAL			DWG. NO.
DESIGNED BY:	APPROVED BY:		R0-001
VERIFIED BY:			
DATE:	SCALE:	1:200	
THE PALESTINIAN WATER AUTHORITY, PA			

WATER RESERVOIR 200m³ ELEVATED TYPE

S=1:100

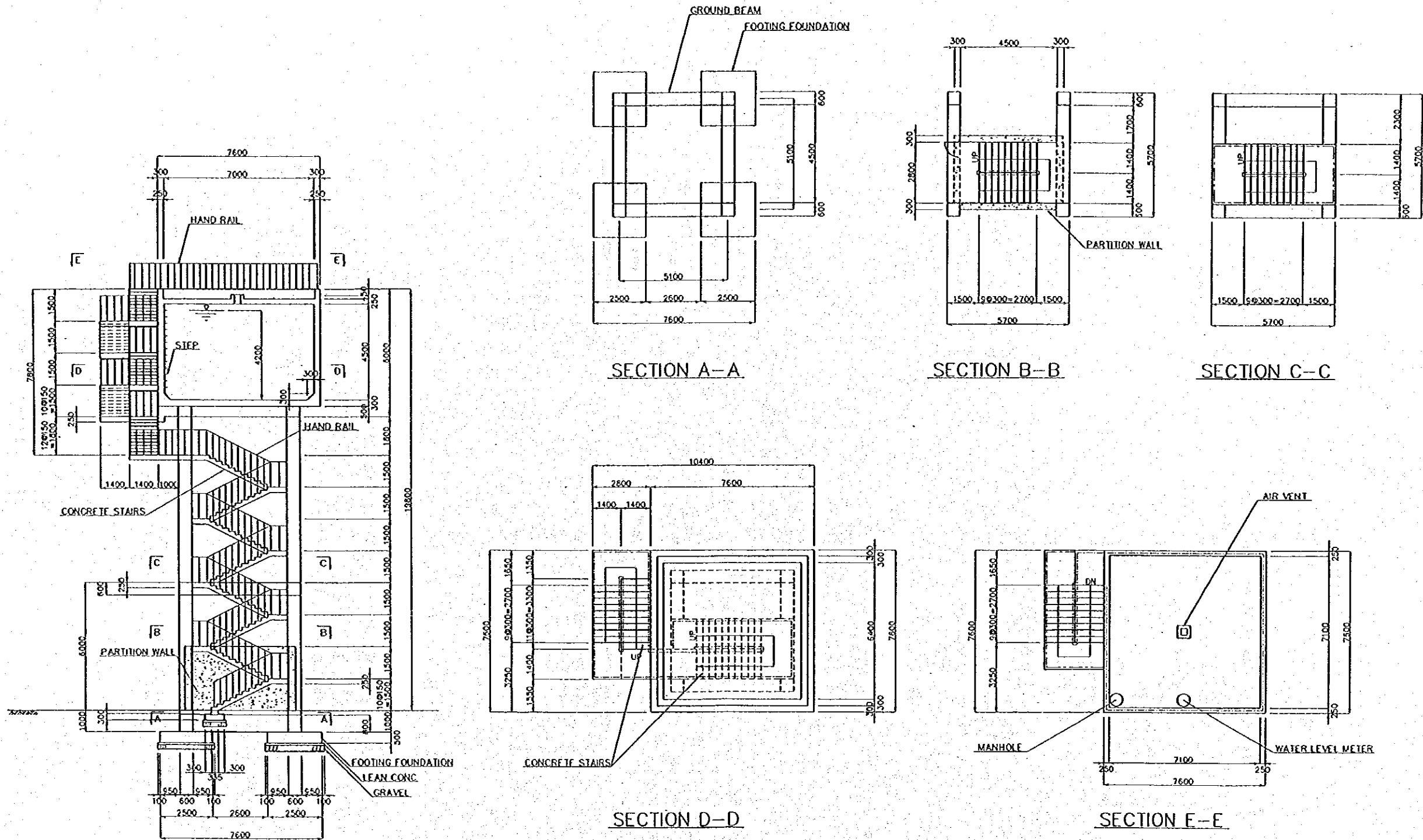

Remarks
 200m³ Elevated Type
 - Iraq Burin Village
 - Dobo'a Village and Ros Tiroh Village
 - Rontis Village

12. Structural Details of Reservoir Tank, Elevated Type, 200 m³

THE PROJECT FOR IMPROVEMENT OF WATER DISTRIBUTION FACILITIES IN THE NORTHERN DISTRICTS OF THE WEST BANK, PHASE - 2			
TITLE WATER RESERVOIR 200m ³ ELEVATED TYPE			
PACIFIC CONSULTANTS INTERNATIONAL		DWG. NO.	
DESIGNED BY:	APPROVED BY:	GE-011-1	
VERIFIED BY:			
DATE:	SCALE:	1:100	
THE PALESTINIAN WATER AUTHORITY, PA			

WATER RESERVOIR 300m³ ELEVATED TYPE

S=1:100

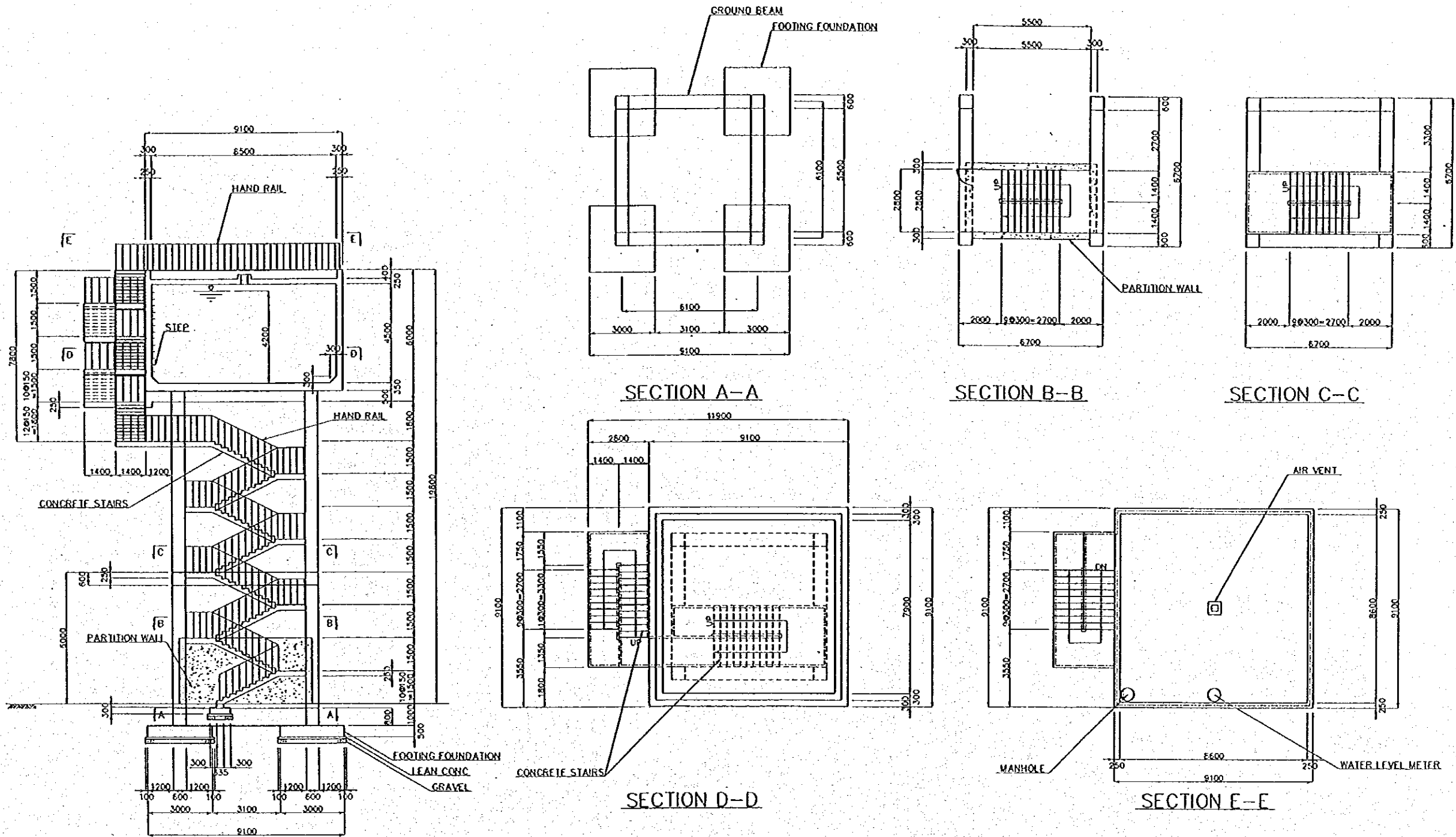

Remarks
 300m³ Elevated Type
 • Boqa Al Sharqiya Municipality
 • Bruqin Village
 • Kofr Ed Deek Village

THE PROJECT FOR IMPROVEMENT OF WATER DISTRIBUTION FACILITIES IN THE NORTHERN DISTRICTS OF THE WEST BANK, PHASE-2			
TITLE WATER RESERVOIR 300m ³ ELEVATED TYPE			
PACIFIC CONSULTANTS INTERNATIONAL		DWS.NO.	
DESIGNED BY:	APPROVED BY:		GE-021-1
VERIFIED BY:			
DATE:	SCALE:	1:100	
THE PALESTINIAN WATER AUTHORITY, PA			

13. Structural Details of Reservoir Tank, Elevated Type, 300 m³

WATER RESERVOIR 500m³ ELEVATED TYPE

S=1:100

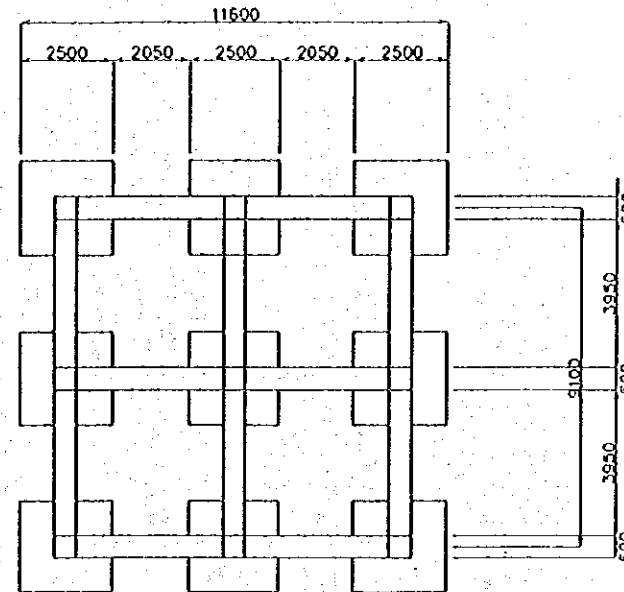
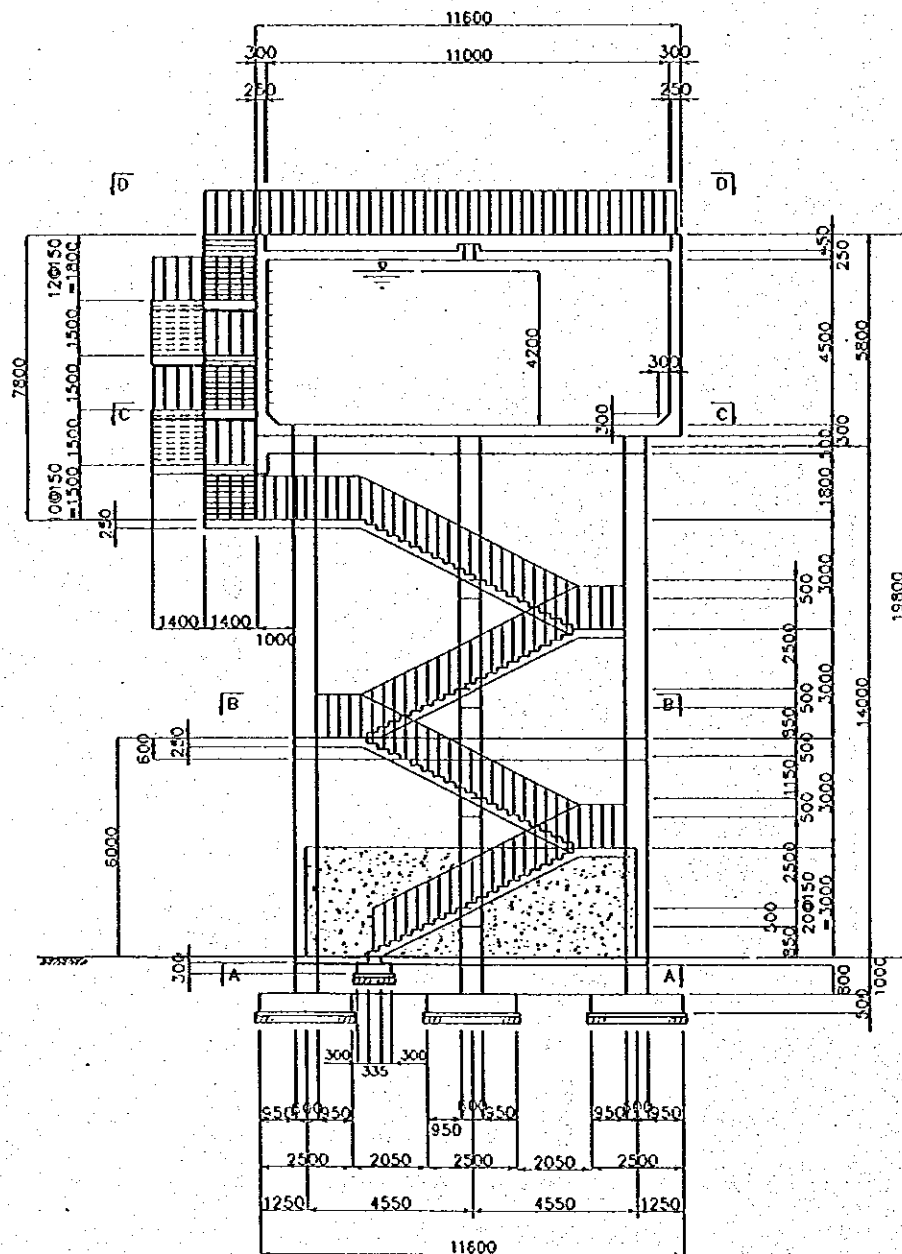

SECTION A-A

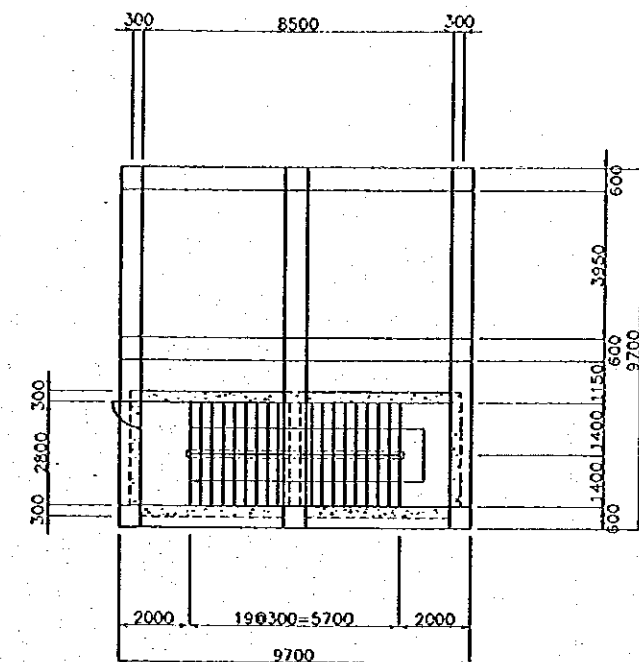

SECTION B-B

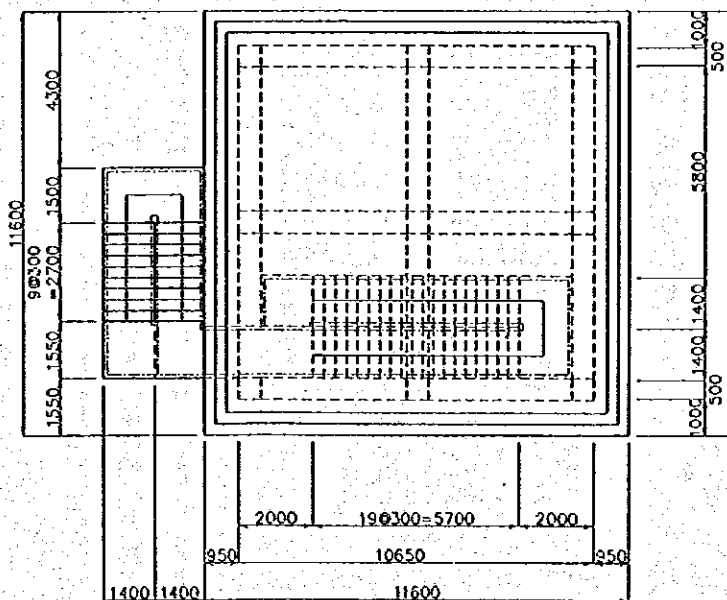

SECTION C-C

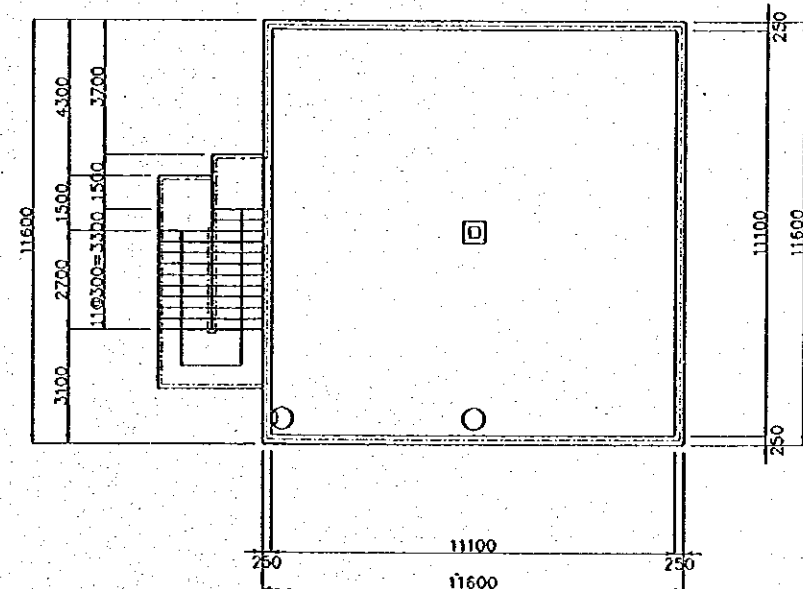

SECTION D-D

Remarks
500m³ Elevated Type
- Attili Municipality

THE PROJECT FOR IMPROVEMENT OF WATER DISTRIBUTION FACILITIES IN THE NORTHERN DISTRICTS OF THE WEST BANK, PHASE-2			
TITLE WATER RESERVOIR 500m ³ ELEVATED TYPE			
PACIFIC CONSULTANTS INTERNATIONAL		DWG. NO.	
DESIGNED BY:	APPROVED BY:	GE-031-1	
VERIFIED BY:			
DATE:	SCALE:	1:100	
THE PALESTINIAN WATER AUTHORITY, PA			

14. Structural Details of Reservoir Tank, Elevated Type, 500 m³

WATER RESERVOIR

500m³ ON-GROUND TYPE

S=1:100

SECTION C-C

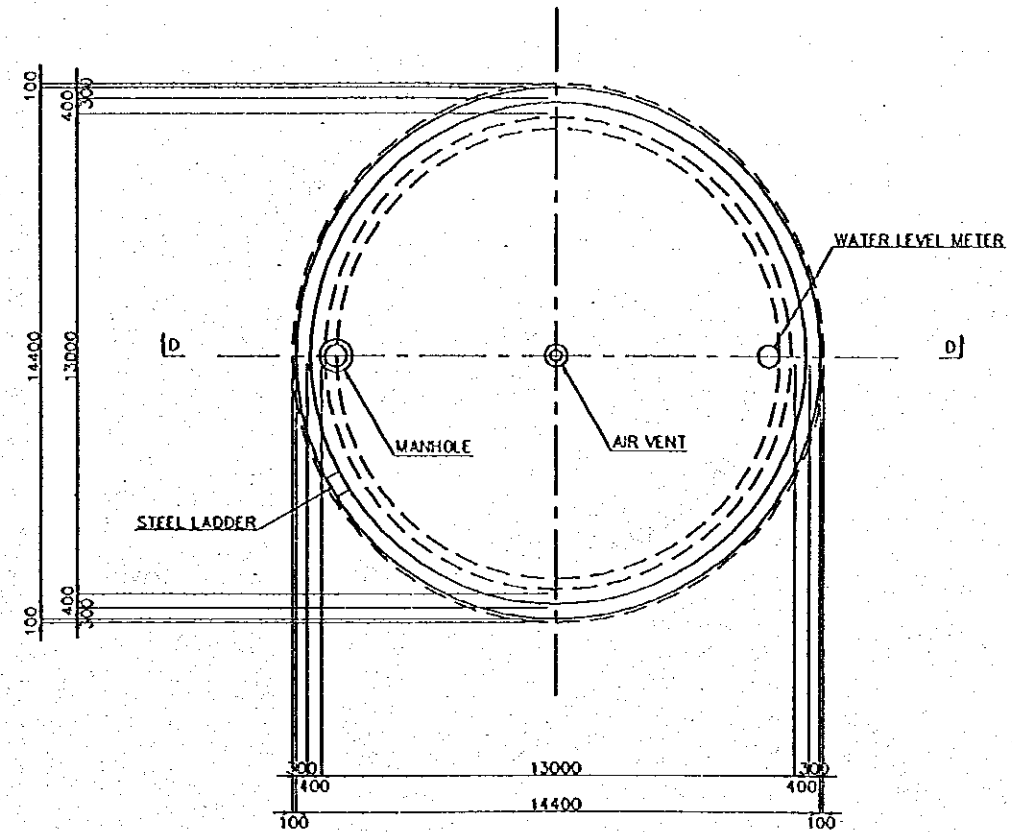

SECTION D-D

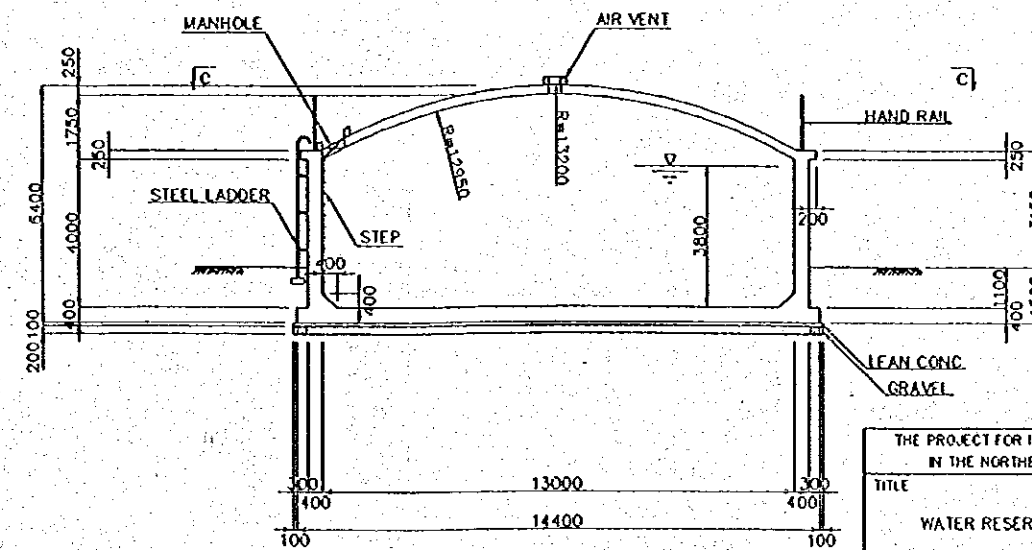

REMARKS
 500m³ On-Ground
 • Hiwara Municipality
 300m³ On-Ground Type
 • Burin Village
 • Urif Village

THE PROJECT FOR IMPROVEMENT OF WATER DISTRIBUTION FACILITIES IN THE NORTHERN DISTRICTS OF THE WEST BANK, PHASE-2		
TITLE WATER RESERVOIR 300m ³ • 500m ³ ON-GROUND TYPE		
PACIFIC CONSULTANTS INTERNATIONAL		DWG. NO.
DESIGNED BY:	APPROVED BY:	CE-041
VERIFIED BY:		
DATE:	SCALE:	
THE PALESTINIAN WATER AUTHORITY, PA		

15. Structural Details of Reservoir Tank, On-ground Type,

500 m³

BOOSTER ROOM

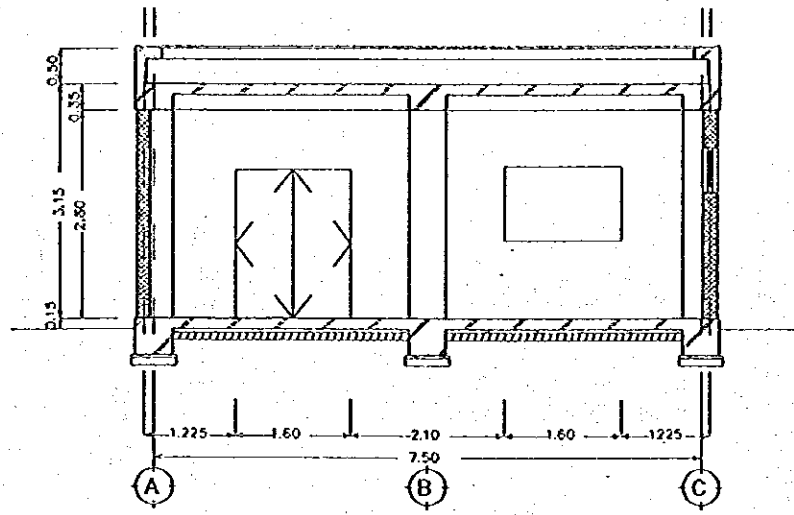

SECTION 1 : 50

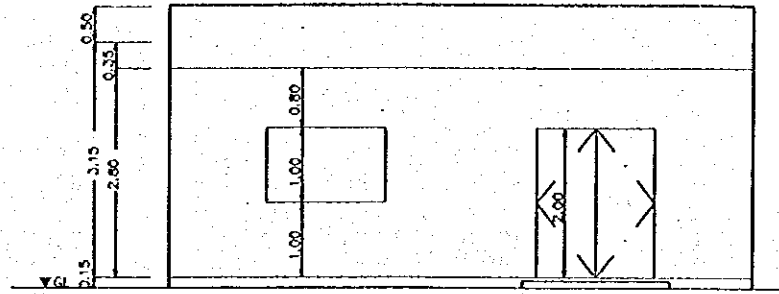

ELEVATION C-A
1 : 50

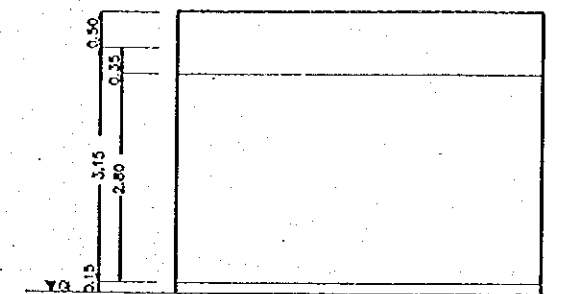

ELEVATION 1-2
1 : 50

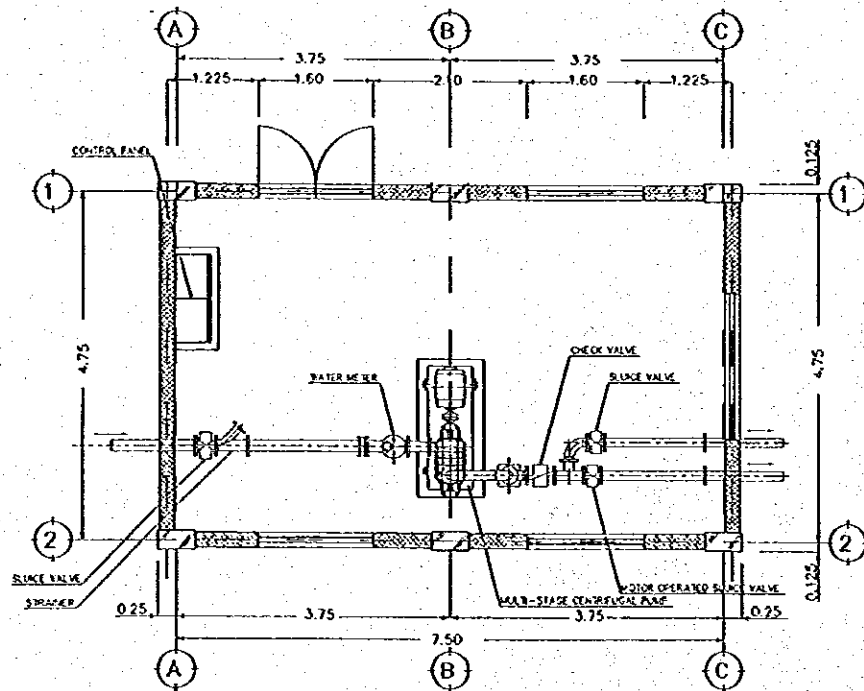

PLAN 1 : 50

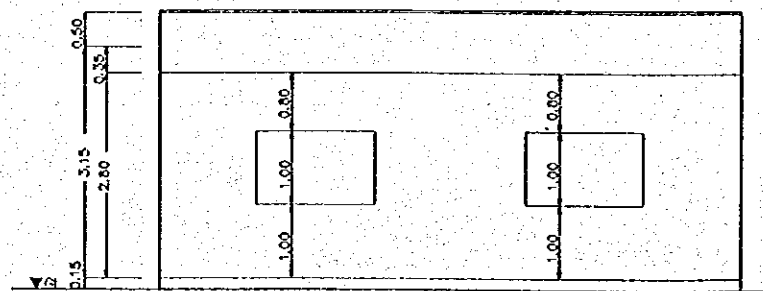

ELEVATION A-C
1 : 50

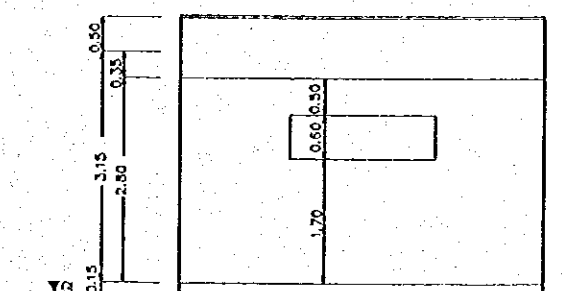

ELEVATION 2-1
1 : 50

THE PROJECT FOR IMPROVEMENT OF WATER DISTRIBUTION FACILITIES IN THE NORTHERN DISTRICTS OF THE WEST BANK, PHASE-2			
TITLE			
BOOSTER ROOM			
PACIFIC CONSULTANTS INTERNATIONAL			DWG. NO.
DESIGNED BY:	APPROVED BY:		GE-111
VERIFIED BY:			
DATE:	SCALE:	1:50	
THE PALESTINIAN WATER AUTHORITY, PA			

16. Booster Pump Station, Pump House Plan

PLAN OF BOOSTER PUMP STATION

ATTIL
1:500

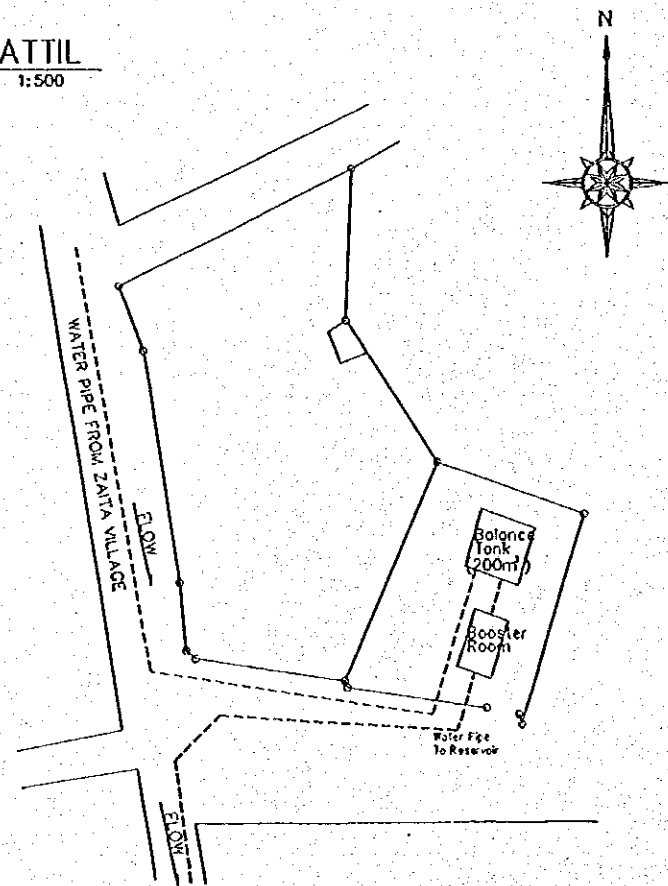

17. Booster Pump Station, General Plan

THE PROJECT FOR IMPROVEMENT OF WATER DISTRIBUTION FACILITIES IN THE NORTHERN DISTRICTS OF THE WEST BANK, PHASE-2			
TITLE			
PLAN OF BOOSTER PUMP STATION			
PACIFIC CONSULTANTS INTERNATIONAL			DWG. NO.
DESIGNED BY:	APPROVED BY:		GE-112
VERIFIED BY:			
DATE:	SCALE:		
THE PALESTINIAN WATER AUTHORITY, PA			

TYPICAL SECTION OF PIPE TRENCH DETAILS

S=1:20

GROUND ROAD

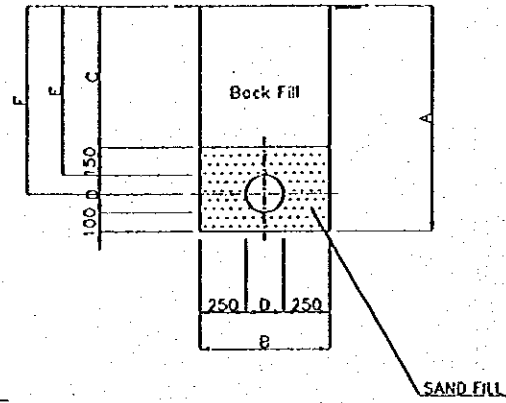

LIST

D	A	B	C	E	F
50	850	550	550	700	725
75	875	575	550	700	737.5
100	900	600	550	700	750
150	1150	650	750	900	975
200	1200	700	750	900	1000

ASPHALT ROAD

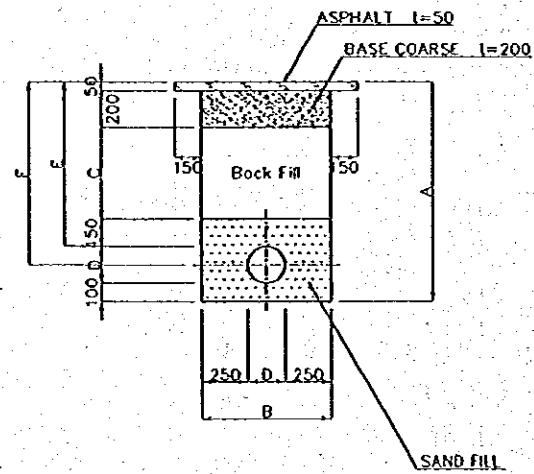

LIST

D	A	B	C	E	F
50	850	550	300	700	725
75	875	575	300	700	737.5
100	900	600	300	700	750
150	1150	650	500	900	975
200	1200	700	500	900	1000

STREAM CORSSING

S=1:30

PLAN

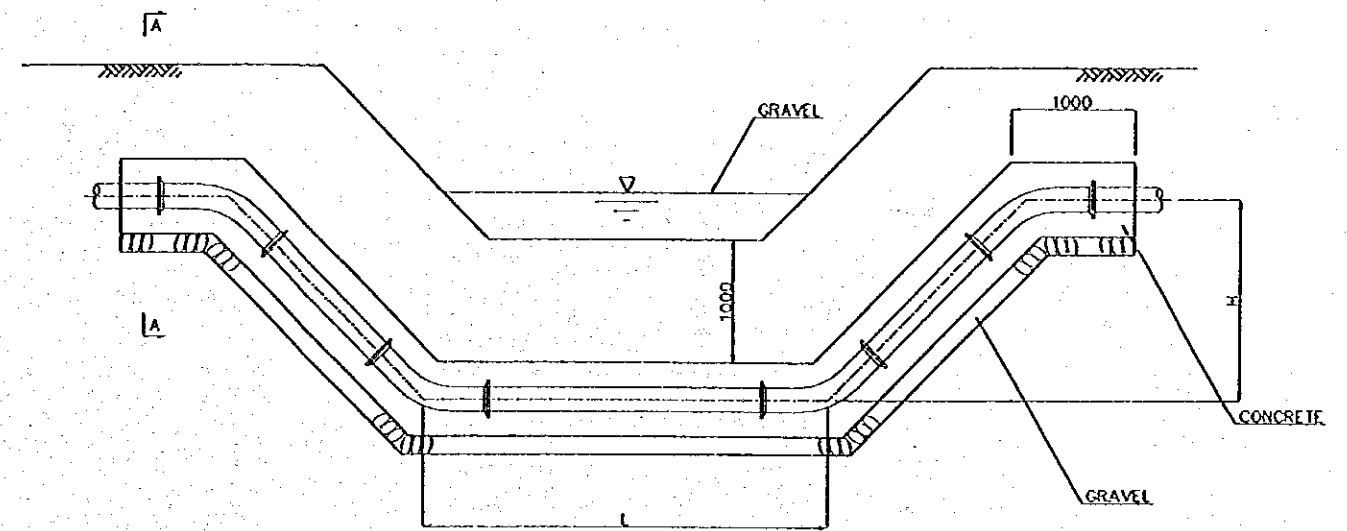

SECTION A-A

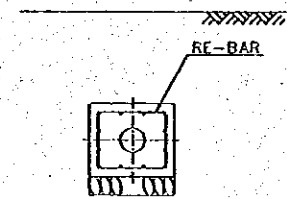

LIST

	L	H
TYPE-1	16400	4000
TYPE-2	12000	3500

18. Standard Section of Pipelines, Siphon, Pipe Protection Work

THE PROJECT FOR IMPROVEMENT OF WATER DISTRIBUTION FACILITIES IN THE NORTHERN DISTRICTS OF THE WEST BANK, PHASE-2	
TITLE TYPICAL SECTION OF PIPE TRENCH DETAILS	
PACIFIC CONSULTANTS INTERNATIONAL	DWG. NO.
DESIGNED BY:	APPROVED BY:
VERIFIED BY:	GE-123
DATE:	SCALE:
THE PALESTINIAN WATER AUTHORITY, PA	

VALVE CHAMBER
FOR $\phi=200$
S=1:30

SECTION A-A

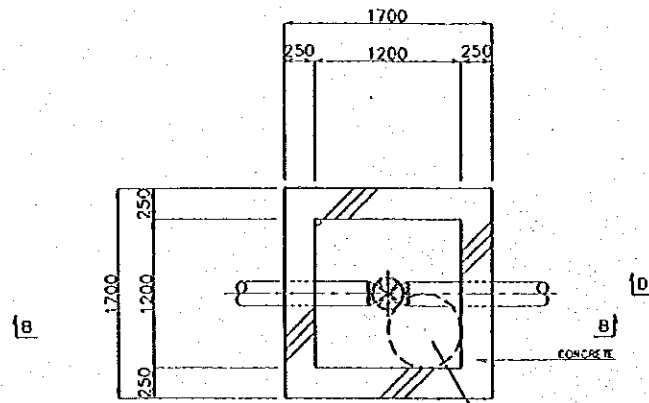

SECTION B-B

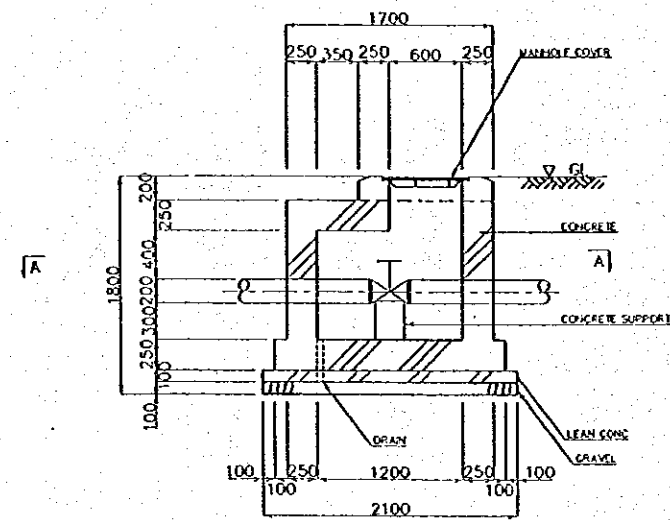

VALVE BOX
FOR $\phi \leq 150$
S=1:30

SECTION C-C

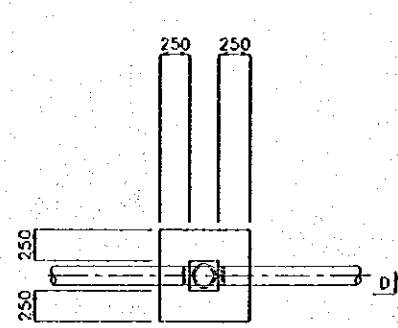

SECTION D-D

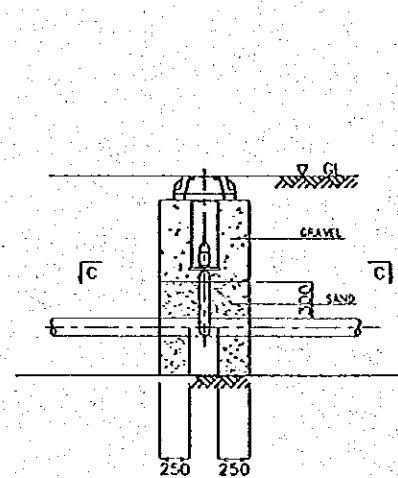

AIR VALVE CHAMBER
FOR $\phi=200$
S=1:30

SECTION E-E

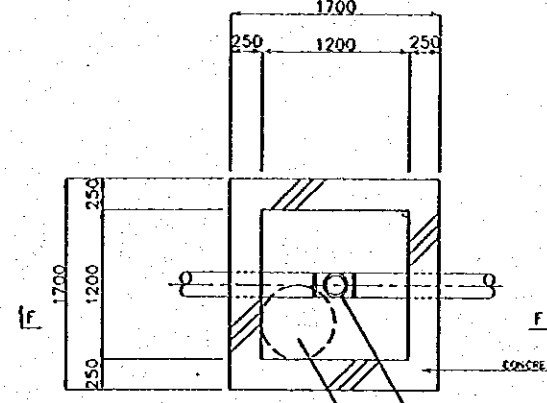

SECTION F-F

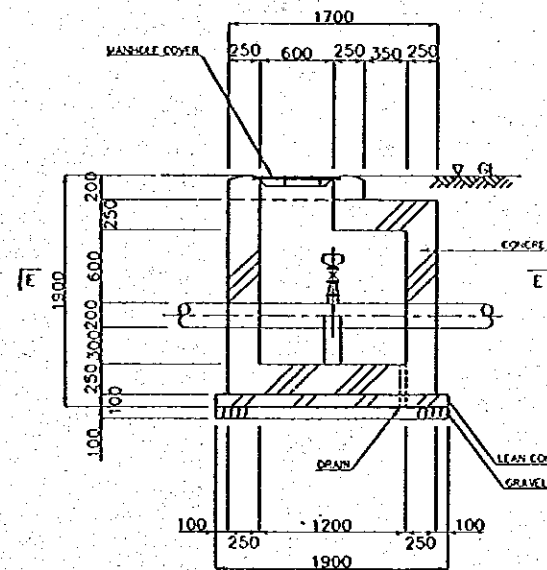

AIR VALVE CHAMBER
FOR $\phi=150$
S=1:30

SECTION G-G

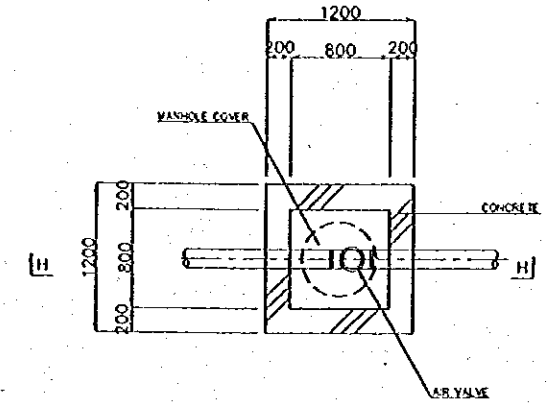

SECTION H-H

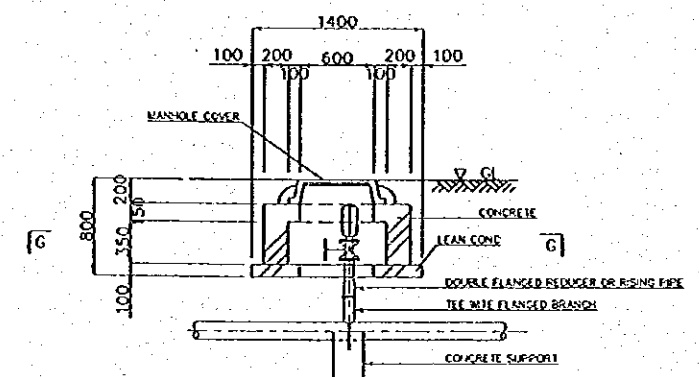

DRAIN VALVE CHAMBER
FOR $\phi=200,150$
S=1:50

SECTION I-I

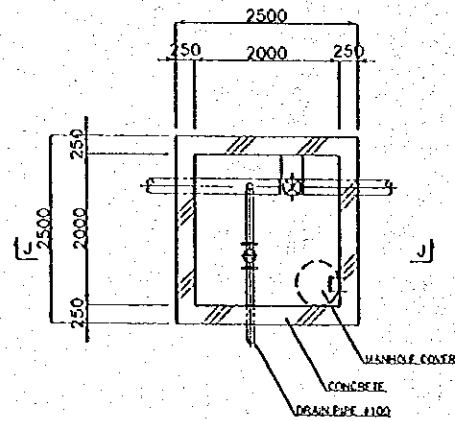

SECTION J-J

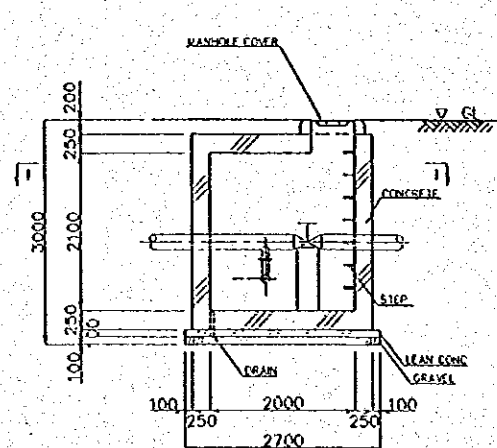

19. Valve Chamber (1/2)

THE PROJECT FOR IMPROVEMENT OF WATER DISTRIBUTION FACILITIES IN THE NORTHERN DISTRICTS OF THE WEST BANK, PHASE-2			
TITLE			
VALVE CHAMBER - 1/2			
PACIFIC CONSULTANTS INTERNATIONAL		DWG. NO.	
DESIGNED BY:	APPROVED BY:	GE-121	
VERIFIED BY:			
DATE:	SCALE:		
THE PALESTINIAN WATER AUTHORITY, PA			

VALVE CHAMBER FOR WATER RESERVOIR
S=1:50
SECTION A-A

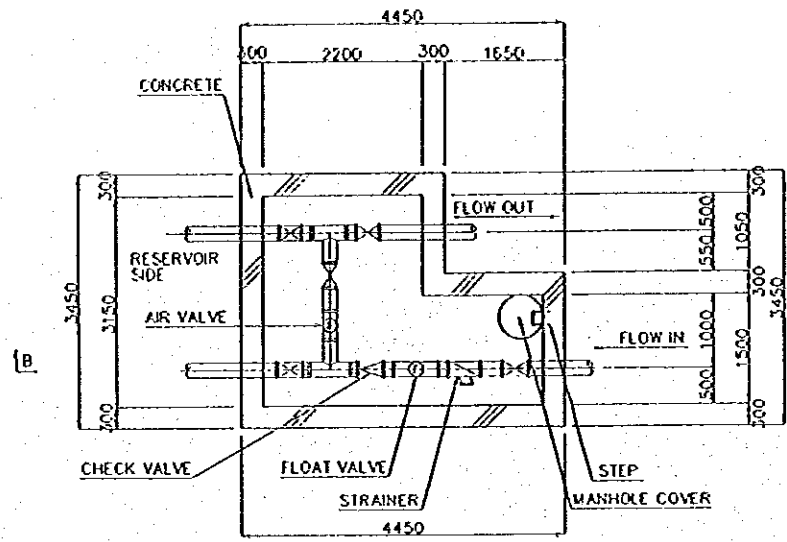

SECTION B-B

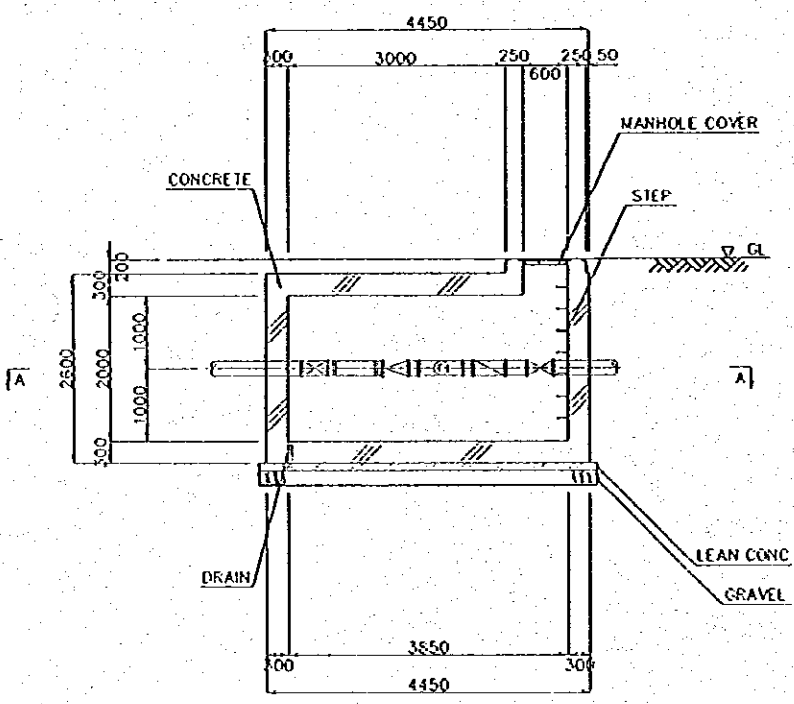

VILLAGE CONNECTION MANHOLE (TYPICAL)
S=1:50
SECTION C-C

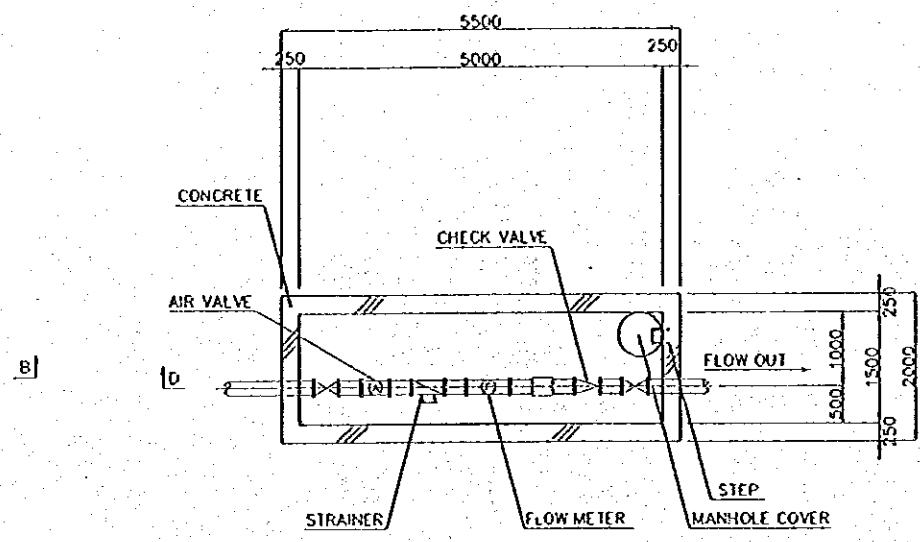

SECTION D-D

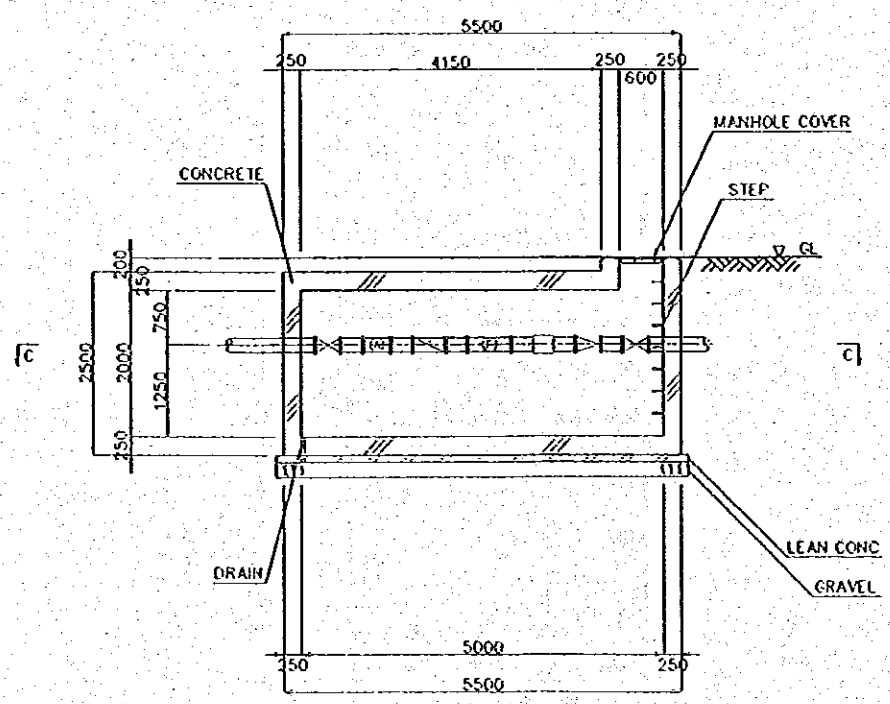

PRESSURE REDUCING VALVE CHAMBER
S=1:50
SECTION E-E

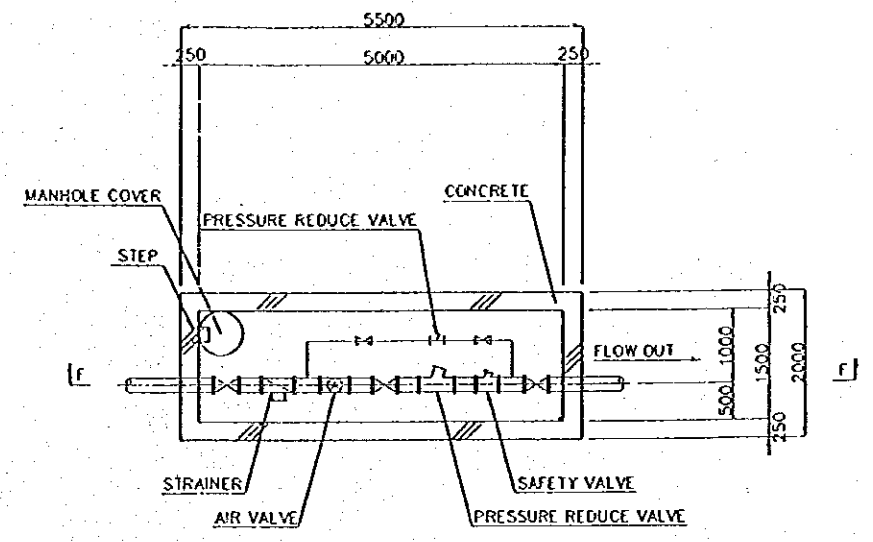

SECTION F-F

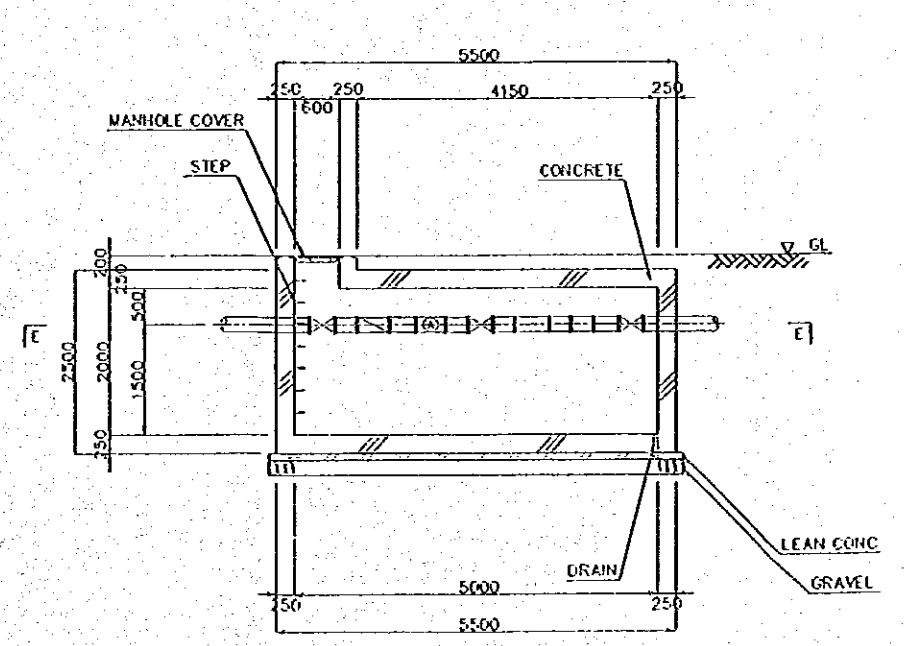

20. Valve Chamber (2/2)

THE PROJECT FOR IMPROVEMENT OF WATER DISTRIBUTION FACILITIES IN THE NORTHERN DISTRICTS OF THE WEST BANK, PHASE-2		
TITLE VALVE CHAMBER - 2/2		
PACIFIC CONSULTANTS INTERNATIONAL		DWC NO.
DESIGNED BY:	APPROVED BY:	CE-122
VERIFIED BY:		
DATE:	SCALE:	1:50
THE PALESTINIAN WATER AUTHORITY, PA		

SCOPE OF PIPE LAYING
FOR HOUSE CONNECTION
S=1:20

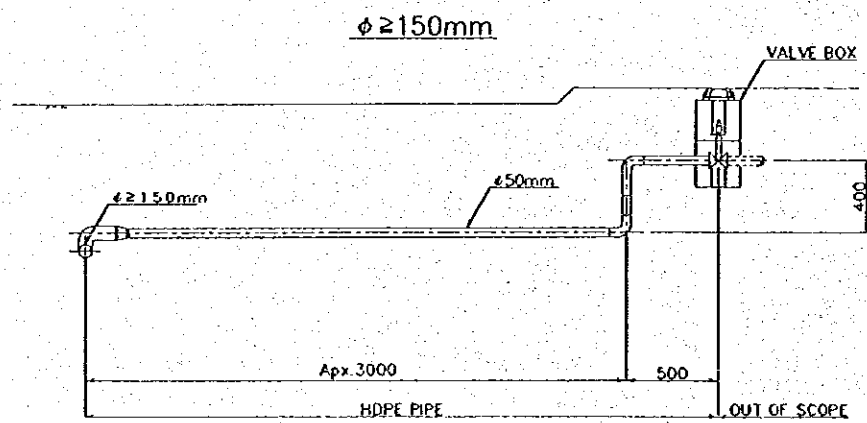
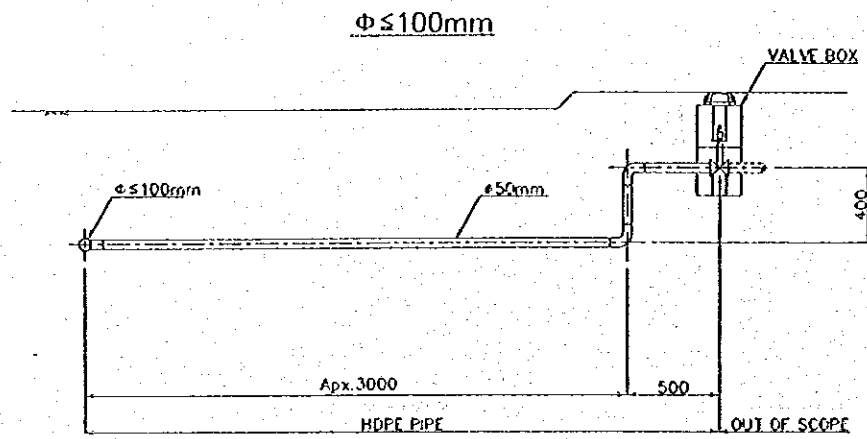

SCOPE OF MATERIAL SUPPLYING
FOR HOUSE CONNECTION
S=1:20

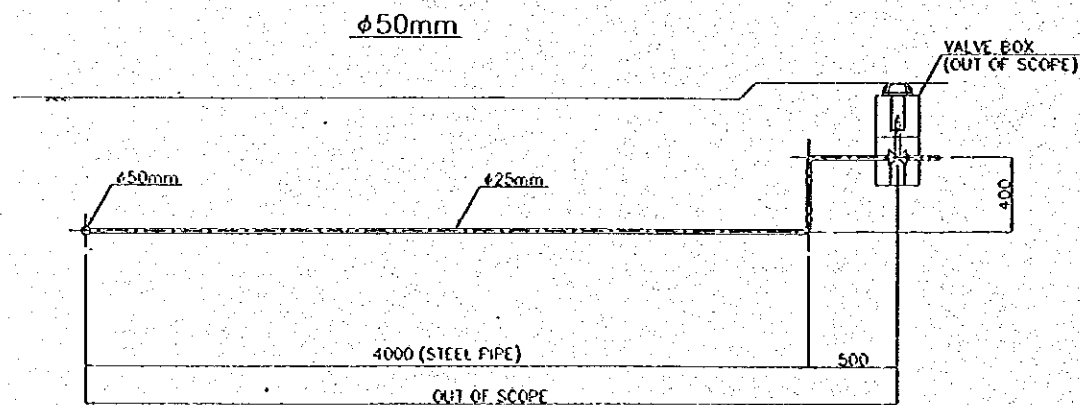

PROTECTION BLOCK
AGAINST WASHED OUT BY RAIN
S=1:50

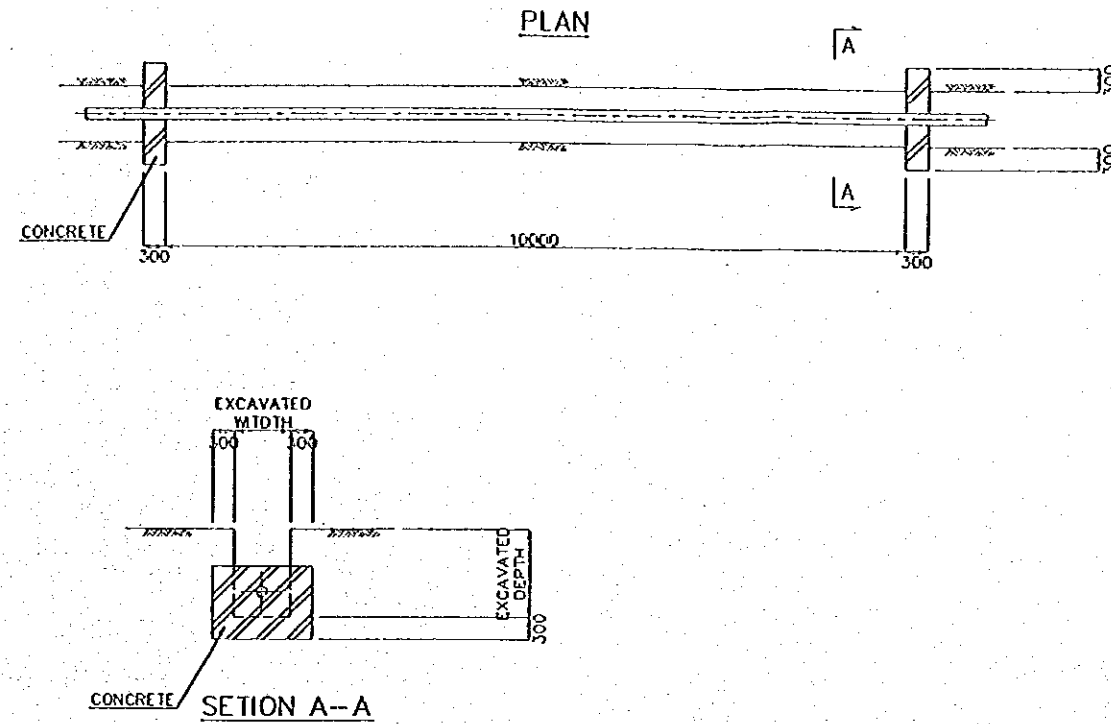

INDICATION POLE
FOR VARIED PIPES
S=1:20

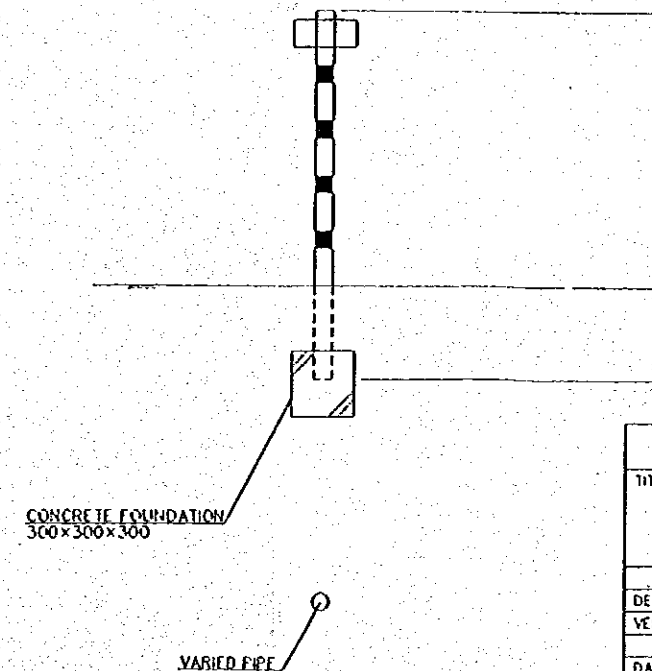

21. House Connection and Others

THE PROJECT FOR IMPROVEMENT OF WATER DISTRIBUTION FACILITIES IN THE NORTHERN DISTRICTS OF THE WEST BANK, PHASE-2		
TITLE		
DETAIL OF PIPE LAYING		
PACIFIC CONSULTANTS INTERNATIONAL		
DESIGNED BY:	APPROVED BY:	CE-124
VERIFIED BY:		
DATE:	SCALE:	
THE PALESTINIAN WATER AUTHORITY, PA		

Appendix 6 Results of Water Quality Analyses

(1) Results of Analyses in the Field Survey

The following table shows the results of water quality analyses conducted during the field survey.

Results of Water Quality Analyses on the Parameters Other than Heavy Metals and Agriculture Chemicals

Parameter	Unit	Palestinian Guidelines	Area	Burqa	Kaffin	Baqa Al Sharkya	Jenin	Daba/Ras Tirha	Hiwara	Izbet Al Tabeeb	Rantis	Burin
			Attil	Spring	Existing Well	Existing Irrigation Well	Existing Well (NO.2)	Existing Well in Ras Atiya	Mekorot	Mekorot	Mekorot	Spring
1. Analyses conducted by local consultant												
NO ₃	Mg/l	50	14.8	16.1	16.5	15.5	12.6	14.3	-	-	-	-
NO ₂	Mg/l	-	ND	ND	ND	ND	ND	ND	-	-	-	-
Na	Mg/l	200	28.0	22.0	39.7	27.3	72.3	25.7	-	-	-	-
Mg	Mg/l	50	27.0	5.9	27.2	26.1	35.3	34.0	-	-	-	-
Hardness	Mg/l	500	301.0	196.3	390.7	324.3	440.3	382.7	-	-	-	-
K	Mg/l	10	4.1	0.6	4.9	2.0	3.8	1.5	-	-	-	-
Ca	Mg/l	100	81.0	70.0	96.0	83.0	108.7	89.0	-	-	-	-
Cl	mg/l	250	62.0	48.3	97.0	60.7	114.3	62.7	-	-	-	-
Fe	mg/l	0.3	0.01	0.003	0.13	0.0	0.0	0.0	-	-	-	-
SO ₄	mg/l	200	24.7	11.6	17.6	18.8	32.9	20.3	-	-	-	-
NH ₄	mg/l	-	ND	ND	ND	ND	ND	ND	-	-	-	-
CO ₂	mg/l	-	145.3	170.7	216.7	141.7	143.3	160.0	-	-	-	-
CO ₃ (CaCO ₃)	mg/l	500	208.3	241.0	173.3	190.7	213.3	213.3	-	-	-	-
F	mg/l	0.6	0.1	0.1	0.1	0.2	0.2	0.03	-	-	-	-
2. Analyses conducted by survey team												
pH		6.5-8.5	7.1	8.0	6.9	7.7	6.4	7.8	7.2	7.1	7.4	-
EC	μ S/cm	-	840	501	902	746	1,320	694	560	711	743	-
Temperature	°C	8-25	24.5	21.0	23.8	23.5	26.2	21.5	25.5	24.0	26.5	-
Bacteria	cfu/ml	-	Nil	4	6	1	6	10	Nil	Nil	Nil	-
Coliform	cfu/ml	-	Nil	5	Nil	TMTC	Nil	10	Nil	Nil	Nil	-
3. Analyses conducted by Laboratory of WBWD												
Total Coliform	cfu/100ml	1	1	60	3	TMTC	-	TMTC	-	-	-	299
Fecal Coliform	cfu/100ml	0	0	1	0	100	-	0	-	-	-	12

Note: TMTC= Too many to count "more than 300 colony".

Chemical analyses were carried out by the local consultants and the other physical and biological parameters were observed by the survey team except for some parameters which were analyzed by the laboratory in WBWD.

As a result, it is concluded that the sampled water is considered safe in view of the values presented in the Palestinian guidelines except for those in the Burqa, the Kaffin, the Baqa Al Sharkya and Daba/Ras Tirah areas, of which biological parameters indicate the values larger than the guidelines. Especially, the existing irrigation well is found to be polluted by fecal

coliform. Since this area is considered to be that new supply facilities are planned to be provided, it is proposed to provided chlorination facility by PA. In the Kaffin area, its raw water is distributed without any treatment, and it is necessary to provide such facilities for chlorination in this area, too. The existing well for the Daba/Ras Tirah area is owned by the Ras Atiya village, the present chlorination facility is planned to be replaced by that to be installed in the booster pump station when the station is completed under the UNDP assistance. Chlorine gas is being applied for most of the chlorination facilities in the areas.

In the west bank, water quality is controlled under the responsibility of PWA, and the facilities necessary for the analyses are provided in the temporary laboratory in WBWD. A mobile car furnished with water quality analysis facilities is also provided to WBWD for this purpose. They are responsible for the water quality control of 300 drinking and irrigation wells and 110 springs, and once a year or two (2) years sampling is made for the parameters such as pH, DO, TDS, EC, Cl, HCO₃, SO₄, NO₃, Na, Ca, Mg, K, F.

The present values indicated in the Palestinian guidelines were determined based on those presented in the Jordanian, Israeli and WHO's guidelines. The data on observed parameters for the previous five (5) years were collected in a form of database, and consequently, it is found that the water of the existing wells and springs which are proposed to be used for the improvement of water distribution facilities is judged to be safe for drinking. However, the parameters on heavy metals such as CN, As, Cr, Cd, Hg, and the effect of agricultural chemicals are not included, because the facilities necessary for the analysis of these parameters are not available in PWA except for some laboratories of universities in the west bank. In the recent analyses under the foreign countries, they take the sampled water to the other countries. According to the hearing survey, there is not such water source that considered to be inapplicable for drinking and any symptoms deemed to be caused by the effect of agricultural chemicals have not been reported so far.

The present staff is three (3) available for water quality control is planned to be increased in the near future, and the Norwegian fund has allocated for assisting in providing analysis facilities, which enables to conduct analyses of the parameters relating heavy metals and agricultural chemicals towards substantial institutional improvement of water quality analysis in the area.

Ministry of Health also participates in water quality control in view of water born diseases. They conduct a periodical biological analyses (general and fecal coliform and of the water sampled in water sources, distribution networks and water taps. Any values out of the allowable range in the guidelines are observed more intensive analyses and directions are made in order to improve the quality of water.

(2) Analyses on Heavy Metals and Agricultural Chemicals

An additional water quality analysis was carried out during the period of the explanation of draft basic design focusing on the parameters of heavy metals and the effect of agricultural chemicals. The existing irrigation well in the Baqa Al Sharkya area is selected for the analysis, because the well water have not yet been used for drinking so far and new water supply facility is provided

for this area.

Results of Additional Water Quality Analysis for the Baqa Al Sharkya Area (Heavy Metals and Agriculture Chemicals)

Parameter	Unit	Palestinian Guidelines	Observed Value	Parameter	Unit	Palestinian Guidelines	Observed Value
(1) Heavy Metals				Cd	mg/l	0.005	<0.005
Ni	mg/l	0.05	0.018	Hg	mg/l	0.001	Not detected
Cr(total)	mg/l	0.05	0.00164	(2) Agriculture Chemicals			
Pb	mg/l	0.01	<0.005	Paraquat			Not Found
As	mg/l	0.05	<0.05	Diquat			Not Found
Sb	mg/l	0.005	Not detected	Simazin			Not Found
Se	mg/l	0.01	<0.05	Glyphosate			Not Found

As for the agriculture chemicals, active parameters of the herbicide selected considering the actual application of chemicals in the farming practices prevailing in the farm lands around the well. As a result, it is concluded that the water of Baqa Al sharkya is judged to be safe without any pollution by agriculture applied in the farm lands near the well.

Appendix 7 Results of Hydraulic Calculation of Water Distribution Networks

List of Figures Indicating the Results

	<u>Page</u>
1. Burqa Area	A - 43
2. Hiwara Area	A - 44
3. Attil Area	A - 45
4. Kaffin Area	A - 46
5. Baqa Al Sharkya Area	A - 47
6. Rantis Area	A - 48

BURQA WATER SUPPLY NETWORK (6:00 hrs)

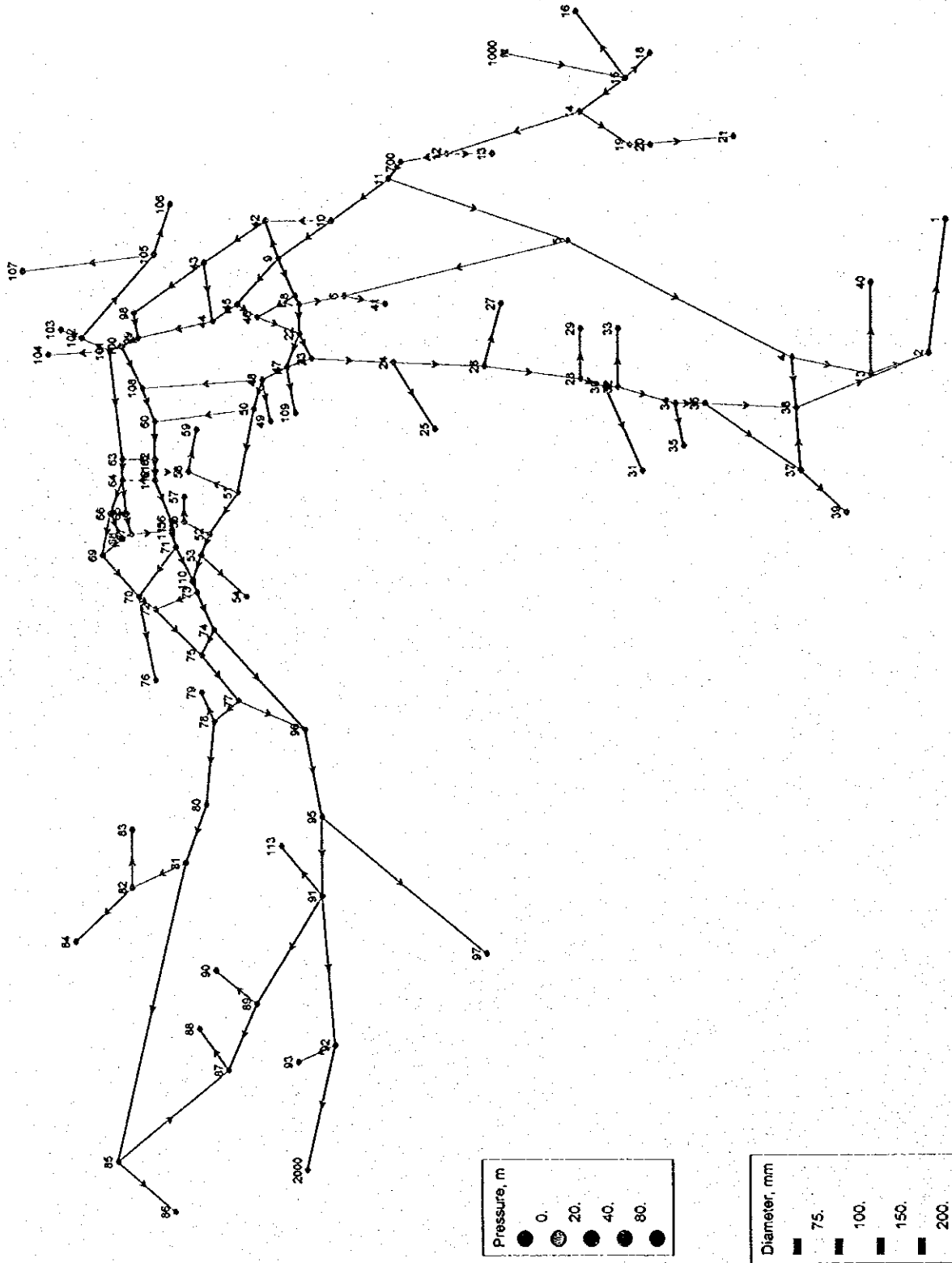

1. Results of Hydraulic Calculations for Distribution Networks in the Burqa Area

HIWARA WATER SUPPLY NETWORK (6:00 hrs)

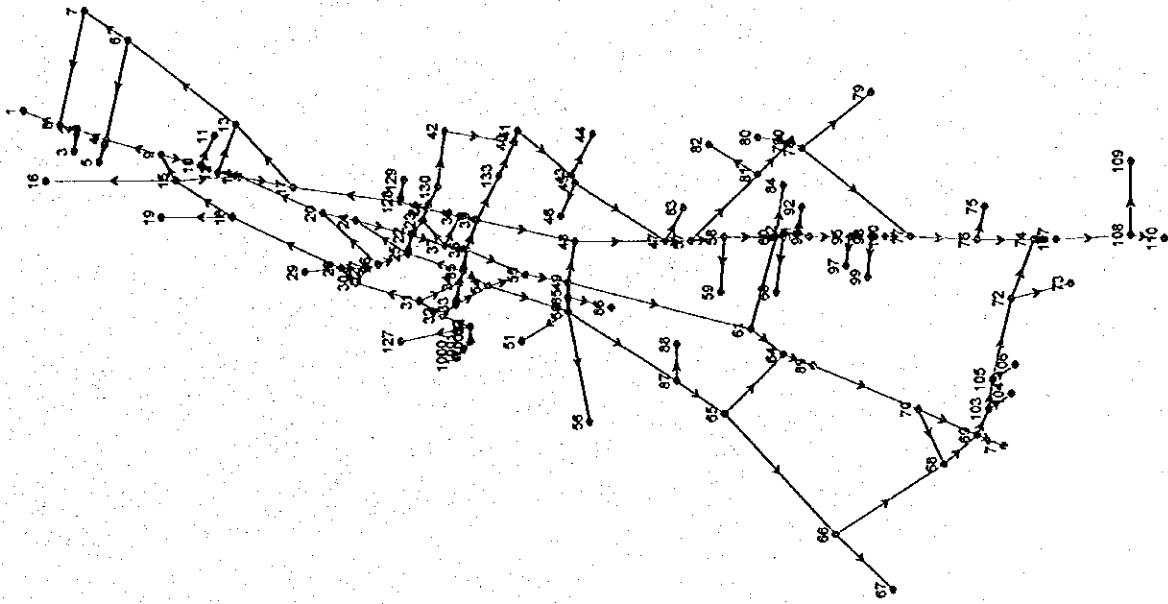
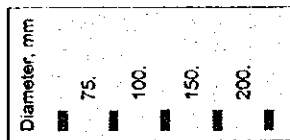
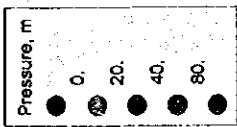

2. Results of Hydraulic Calculations for Distribution Networks in the Hiwara Area

ATTIL MUNICIPALITY WATER NETWORK/ TULKARM (6:00 hrs)

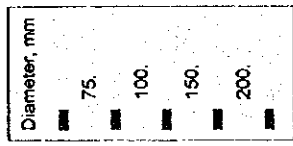
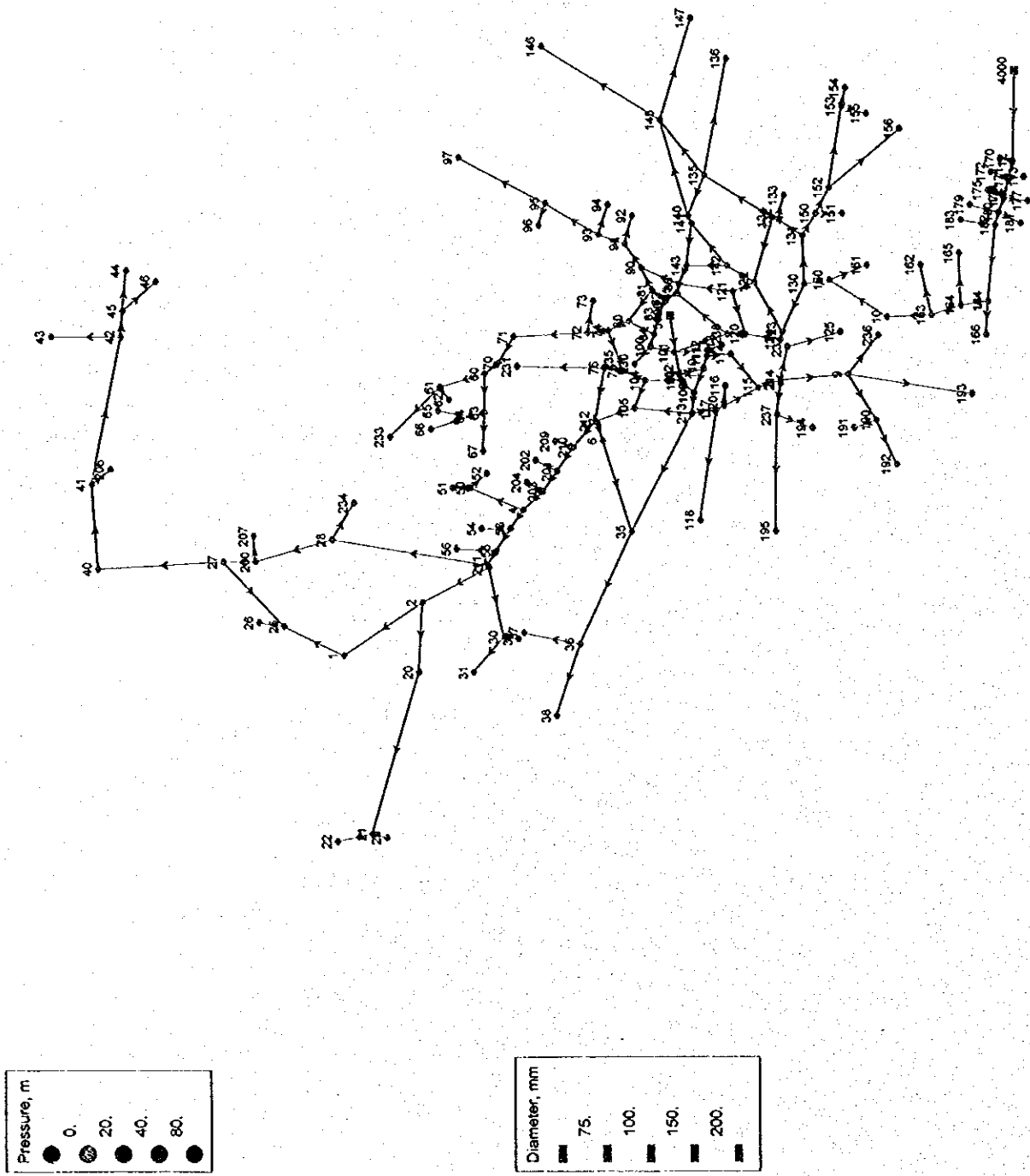

3. Results of Hydraulic Calculations for Distribution Networks in the Attil Area

KAFFIN WATER SUPPLY NETWORK (6:00 hrs)

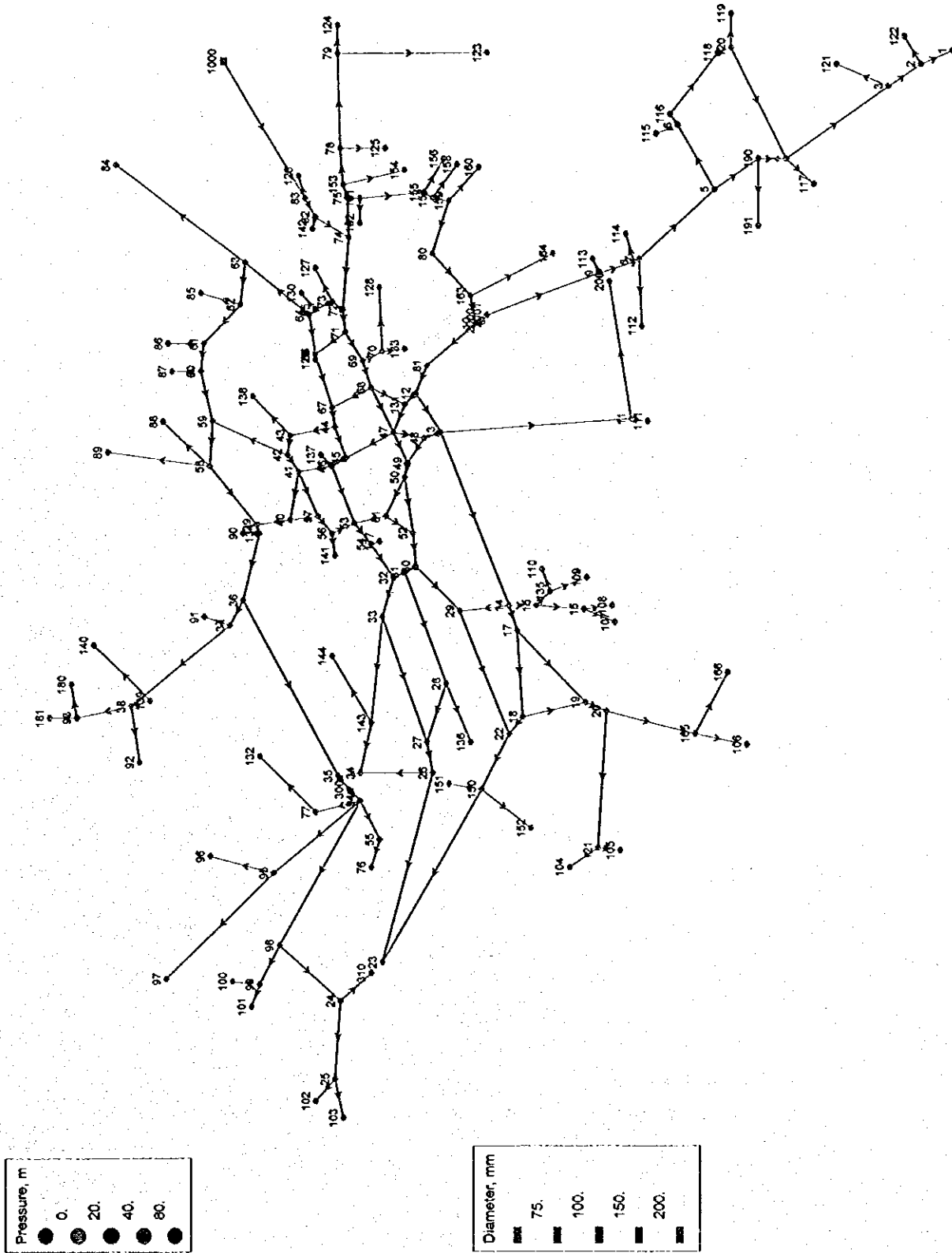

4. Results of Hydraulic Calculations for Distribution Networks in the Kaffin Area

BAQA AL SHARQIYA WATER SUPPLY NETWORK (6:00 hrs)

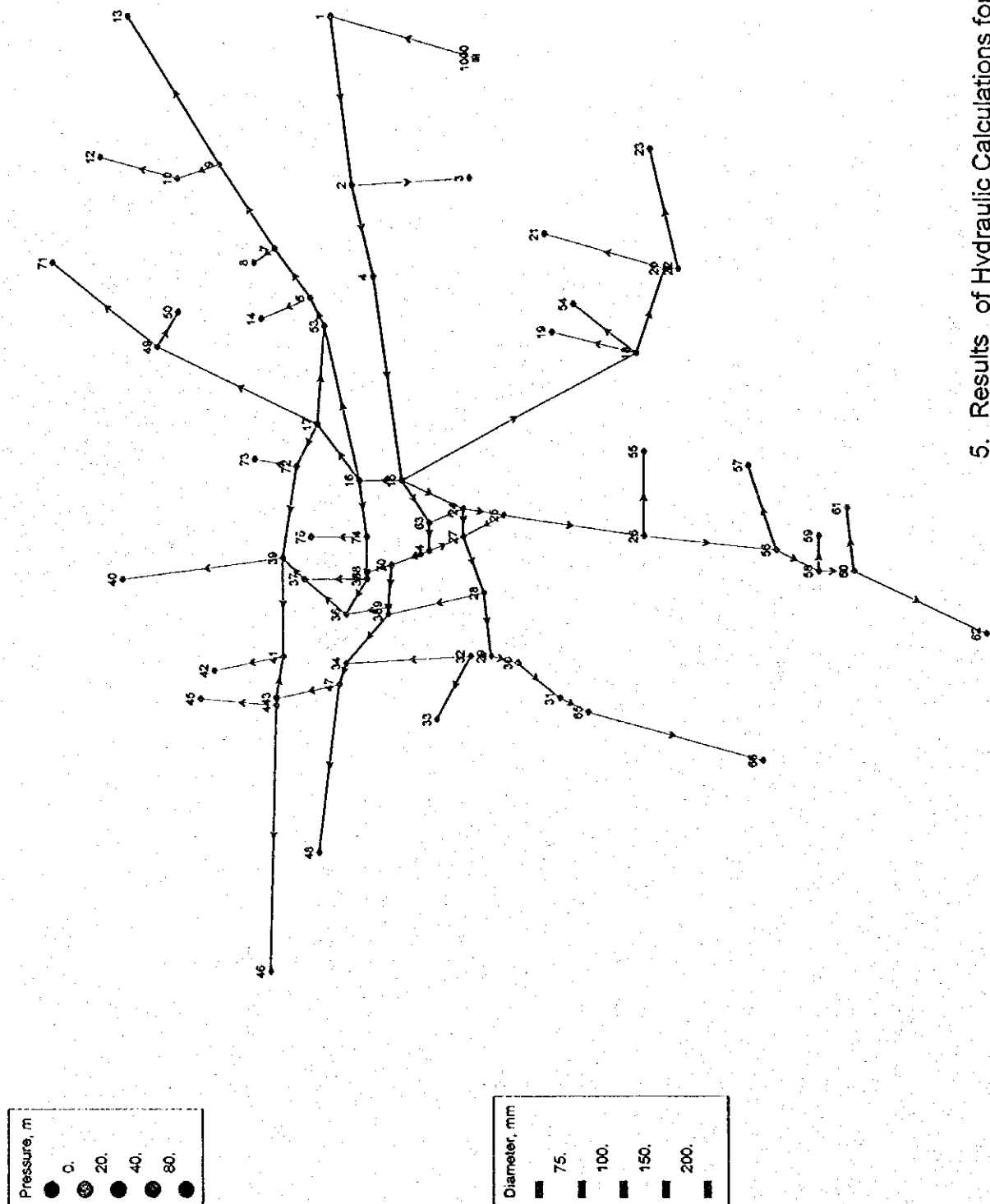

5. Results of Hydraulic Calculations for Distribution Networks in the Baqa Al Sharkya Area

RANTIS WATER SUPPLY NETWORK (6:00 hrs)

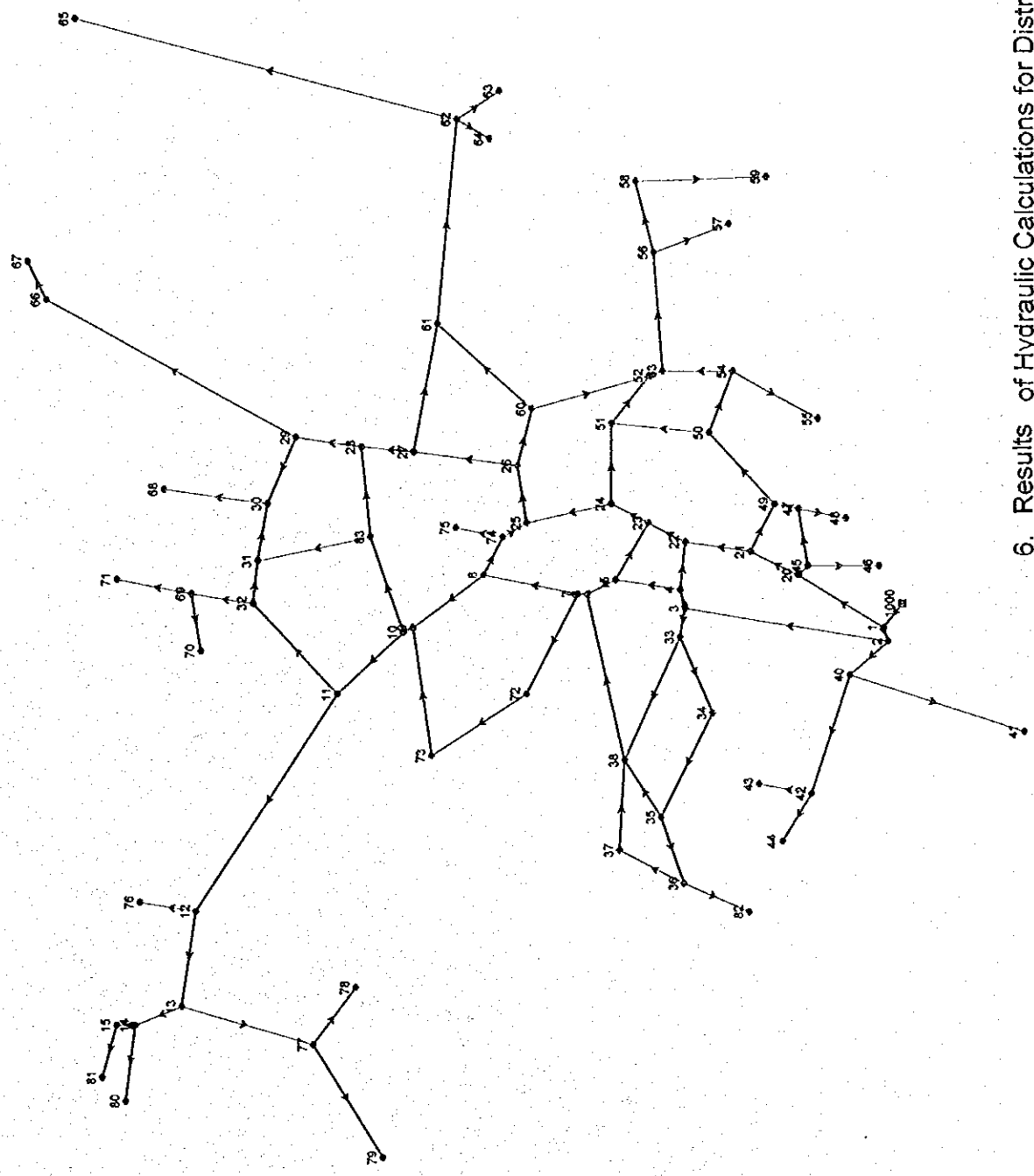
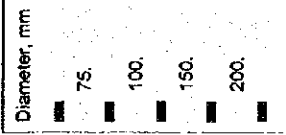

6. Results of Hydraulic Calculations for Distribution Networks in the Rantis Area

Appendix 8 References

No.	Title	Issued by:
1	Palestine Central Bureau of Statistics, Construction Contractors' Survey - 1997	PCBS
2	Water Supply Facilities Map	PWA
3	Water Supply Facility Master Plan for the Nablus Service Area, Preliminary Report	PWA
4	Domestic Wells in West Bank	PWA
5	Israeli Wells in West Bank	PWA
6	Palestinian Standard (Drinking Water)	Palestinian Standard Institute
7	Planning and Design Guidelines	PWA
8	General Technical Specifications for Water Supply Networks	PWA
9	Water Supply Facility Master Plan for Jenin Service Area	PWA
10	West Bank Water and Sanitation Project Metap Study on Project Design	PWA

JICA