

国際協力事業団  
ルーマニア国  
水利・森林・環境保護省

ルーマニア国  
南部森林保全計画調査

ファイナルレポート

資料編

平成 12 年 1 月

共同企業体

財団法人 林業土木コンサルタンツ  
株式会社 パスコインターナショナル



1155098(5)

ルーマニア国南部森林保全計画調査  
ファイナルレポート

資料編

目次

区分		項目		頁	F/R
A	気象・水文	App. A-1	Monthly precipitation at Craiova Observatory and Bailesti Observatory	1	2-2-1
		App. A-2	Annual mean temperature at Craiova Observatory and Bailesti Observatory 1962 - 1994	1	2-2-1
		App. A-3	Map of Main River System in Olt County and Dolj County	2	2-2-2
		App. A-4	Precipitation per hour at Criva Forest	3	2-2-4
		App. A-5	Precipitation and Water Suction	8	2-4-4
		App. A-6	Groundwater Distribution Ma	11	2-4-4
		App. A-7	Soil porosity ratio on each study point	12	2-4-6
B	土壌	App. B-1	Positions of Soil Profile Points	13	2-2-3
		App. B-2	Soil Profile Points and Soil Classification	14	2-2-3
		App. B-3	Romanian Soil Classification Systems and Sub Type	17	2-2-3
		App. B-4	Reading of codes and marks of Romanian soil classification in FAO/UNESCO soil classification 1988	18	2-2-3
		App. B-5	Measurement data of soil hardness (soil penetration resistance)	22	2-6-1
C	社会経済	App. C-1	Statistics of Romanian Economy	27	2-3-1
		App. C-2	Results of the Socioeconomic Interview Survey Regarding National Forests	36	2-3-2
		App. C-3	防風林聞き取り調査	44	2-3-2
D	森林生態・森林衰退	App. D-1	Positions of Survey Plots	47	2-4-3
		App. D-2	Belt-transect Survey for the Classification of Forest Vegetation Types	48	2-4-3
		App. D-3	Forest Profile Diagrams and Crown Projection Diagrams of the Belt-transects Each Forest Vegetation	49	2-4-3
		App. D-4	Survey of Natural Seeding in Plot of the Belt-transect	55	2-4-3
		App. D-5	Data of Litter Trap Survey (July to October in 1998, Seaca-Optosani Forest)	56	2-4-3
		App. D-6	Survey Plots for the Forest Decline	57	2-4-3
		App. D-7	Forest Decline Grade of Each Trees on Each Belt-Transect	58	2-4-3
		App. D-8	Percentage of Declined Trees at Survey Forest Stands	71	2-4-3
		App. D-9	Rate of Declined Trees at Survey Forest Stands	71	2-4-3
		App. D-10	Tree Species and Die Back Grade of the Belt-transect	72	2-4-3
		App. D-11	Rate of Declined Trees at Belt-Transect Survey Points	73	2-4-3
		App. D-12	Monitoring Survey in Romania	74	2-4-7
		App. D-13	Result of Forest Survey	75	2-4-3
		App. D-14	Food Consumption of <i>Lymantria dispar</i> larva Grown in Romania	78	2-4-7
		App. D-15	Food Consumption and Frass amount of <i>Lymantria dispar</i> larva Grown in Romania	78	2-4-7
		App. D-16	Frass Amount of <i>Lymantria dispar</i> larva Collected by a Litter Trap in <i>Quercus</i> forests	79	2-4-7
		App. D-17	Weight of Dry Frass of <i>Lymantria dispar</i> larva Collected by a Litter Trap in <i>Quercus</i> forests	80	2-4-7
		App. D-18	Number and Size of Dry Frass of <i>Lymantria dispar</i> larva Grown in Romania	81	2-4-7

区分		項目		頁	F/R	
D	森林生態・森林衰退	App.	D-19	Food consumption (leaf area cm <sup>2</sup> ) and frass number of <i>Lymantria dispar</i> larva grown in Romania	81	2-4-7
		App.	D-20	Frass Amount of <i>Lymantria dispar</i> Collected by a Litter Trap (DBH 80cm)	81	2-4-7
E	森林施業	App.	E-1	Organization Chart of Ministry of Waters, Forests and Environmental Protection from March,1999	83	2-4-1
		App.	E-2	Area of the Entire Forests and Damaged Forests by Site Index and Forest Range Office	84	2-4-4
		App.	E-3	収穫表	85	2-4-5
		App.	E-4	CO <sub>2</sub> 固定量の算出量の考え方	105	2-4-6
		App.	E-5	Area of Damaged Forests by Forest Range Office and Forest Functions in Romania	108	2-4-6
		App.	E-6	Designation of the Seed Stands	109	2-4-7
		App.	E-7	Thinning System and Estimated Value of Standing Trees	110	3-2
F	森林復旧計画	App.	F-1	Felling Volume of Damaged Forests by Damage Grade and Forest Range Office	111	3-2-2
		App.	F-2	Felling Volume of Damaged Forests by Forest Range Office, Forest Management Type and Damage Grade	112	3-2-2
		App.	F-3	Area of Damaged Forests by Forest Range Office, Forest Function and Damage Grade	113	3-2-2
		App.	F-4	Felling Volume of Damaged Forests by Forest Range Office Forest Function and Damage Grade	114	3-2-2
		App.	F-5	Selection Standards of Planting Species	115	3-3-1
		App.	F-6	Working Item Arrangement Map of General Arboretum and Forestry Work Demonstration Forest	116	3-9
		App.	F-7	抵抗性育種技術の開発	118	3-10
		App.	F-8	Area of Damaged Forest by Soil Code, Damaged Grade	128	2-2-1
		App.	F-9	Area of Damaged Forest by Stand age, Damaged Grade	129	2-2-1
		App.	F-10	Damaged Forests Area and Volume by Forest Range Office, UP and Damage Grade	130	2-2-1
		App.	F-11	Damaged Forest Area and Volume by Forest Range Office, UP and Stand Structure	132	2-2-1
		App.	F-12	Prevention Forest Area and Volume by Forest Range Office, UP and Tree Species	134	2-2-2
		App.	F-13	Length of Forest Mantle by Forest Range Office and UP	136	3-5/4-3
		App.	F-14	Compilation Annual Cost by County	137	3-11/5-2
		App.	F-15	Cost by Operation Year (Supply of Machinery)	141	3-8/5-2
		App.	F-16	Cost by Operation Year (Supply of Hand Tools)	142	3-8/5-2
		App.	F-17	Cost by Operation Year (Cruising)	143	3-11/5-2
		App.	F-18	Income by Operation Year (Damaged Woods Selling)	150	3-11/5-2
		App.	F-19	Cost by Operation Year (Production Cost)	163	3-11/5-2
		App.	F-20	Cost by Operation Year (Silviculture)	168	3-11/5-2
		App.	F-21	Cost by Operation Year (Drainage and Infiltration Works)	178	3-11/5-2
		App.	F-22	Reforestation Cost per ha (Forest Mantle Replantation)	179	3-11/5-2
		App.	F-23	Improvement of Forest Roads	180	3-7/5-2
		App.	F-24	Total Cost for General Arboretum	181	3-9/5-2
		App.	F-25	Total Cost for Forestry Work Demonstration Forest	182	3-9/5-2
		App.	F-26	Silvicultural System	184	3-3/5-2
		App.	F-27	Reforestation Cost per ha	189	3-3/5-2
		App.	F-28	Labor Volume by Operation Year	197	5-2-3

区分		項目		頁	F/R	
F	森林復旧計画	App.	F-29	Operation Volume by Operation Year (Tending)	201	3-3/5-2
		App.	F-30	Restoration Targets for Damaged Forest by Site Index, Damage Grade	203	1-2-3/ 5-2
		App.	F-31	Appraised Wood Value for Damaged Forest by Site Index	206	5-2
		App.	F-32	Calculation of wood Volume on Each Destination	209	5-2-1
		App.	F-33	Final Desired Growing Stock	210	5-2-1
		App.	F-34	Portion of Saw Log for Industry	210	5-2-1
		App.	F-35	Estimation price of stumpage in future	211	5-2-1
		App.	F-36	Calculation of Quantity of Machinery	212	5-2-1
		App.	F-37	Benefits of Forest Functions Other than Wood Production	216	5-2-2
		App.	F-38	Calculation of Soil Conservation Effect	217	5-2-2
		App.	F-39	Plantation Area by Operation Year, Forest Management Type, Damage Forest	218	3-11/5-2
		App.	F-40	Required Number of Nursery Stock by Species and Operation Year	219	3-4/5-2
		App.	F-41	Index sheet for thematic map	221	-
調査実施体制				-	-	
Minutes of Meeting				-	-	

## Appendix A 気象・森林水文

---

## Appendix A: 気象・水文

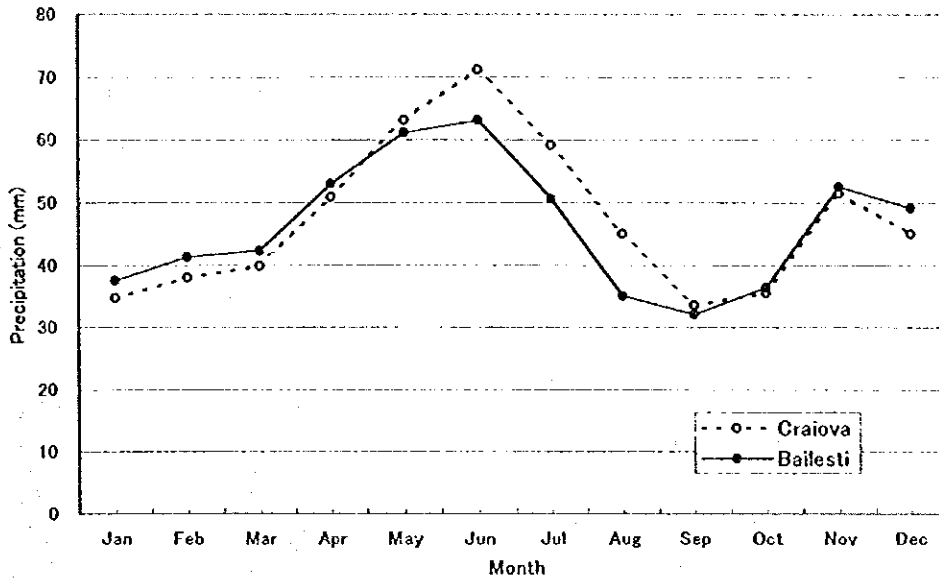

Appendix A-1 Monthly precipitation at Craiova Observatory and Bailesti Observatory

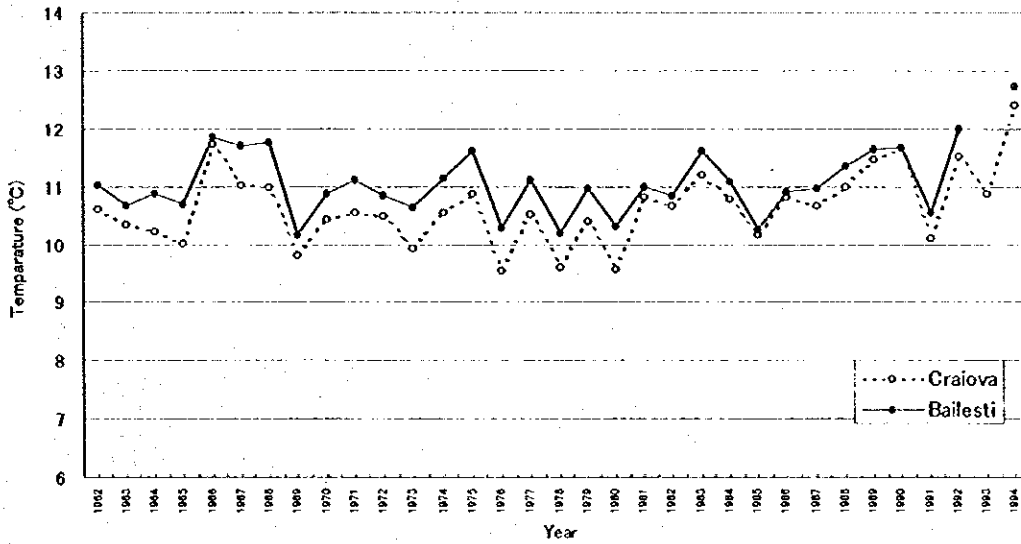

Appendix A-2 Annual mean temperature at Craiova Observatory and Bailesti Observatory (1962 - 1994)

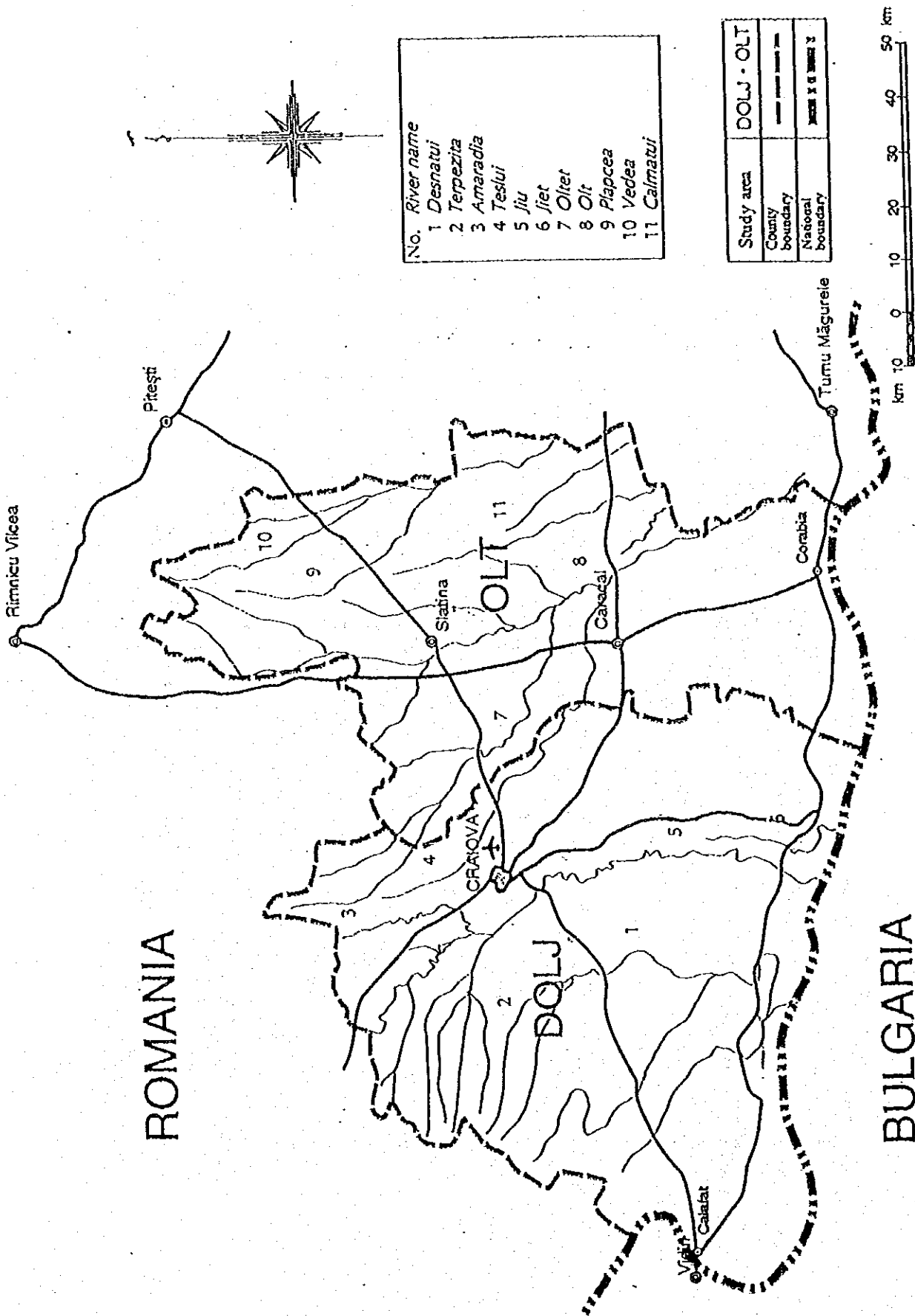

Appendix A-3 Map of Main River System in Olt County and Dolj County



Appendix A-4 Precipitation per hour at Criva Forest

June, 1993		Precipitation per Hour																				Observatory Criva						
Day/Time	1	2	3	4	5	6	7	8	9	10	11	12	13	14	15	16	17	18	19	20	21	22	23	24	Total	Remarks		
1																									0.0			
2																										0.0		
3																										0.0	Start of observation	
4																										0.0		
5																										0.0		
6																										0.0		
7																										0.0		
8																										0.0		
9																										0.0		
10																										0.0		
Sub Total																										0.0		
11																										0.0		
12																										0.0		
13	1.0	3.0	0.5	1.0	1.0	2.0		1.0	0.5	0.5						0.5				8.0			0.5	0.5	10.5			
14																										0.0		
15																										0.0		
16																										0.0		
17																										0.0		
18	3.5	6.0	7.0	3.0	2.5			0.5																		22.5		
19																										0.0		
20																										0.0		
Sub Total																										41.0		
21																										0.0		
22																										0.0		
23																										0.0		
24																										0.0		
25																										0.0		
26																										0.0		
27																										0.0		
28																										0.0		
29																										3.0		
30																										0.0		
31																										0.0		
Sub Total																										3.0		
Total																										47.0		

July, 1993		Precipitation per Hour																				Observatory Criva					
Day/Time	1	2	3	4	5	6	7	8	9	10	11	12	13	14	15	16	17	18	19	20	21	22	23	24	Total	Remarks	
1																										0.0	
2																										0.0	
3																										0.0	
4						0.5			0.5																	1.0	
5																										0.0	
6																										0.0	
7																										4.5	
8																0.5										0.5	
9																										0.0	
10																										0.0	
Sub Total																										6.0	
11																										0.0	
12																										0.0	
13																										0.0	
14																										0.0	
15																										0.0	
16				0.5	5.0	5.0	2.0		1.0	1.0	2.5	6.5	1.0	0.5	1.0	3.5	3.5	7.5	1.5	0.5					42.5		
17																										0.0	
18																										0.0	
19																										0.0	
20																										0.0	
Sub Total																										42.5	
21																										0.0	
22																										0.0	
23																										0.0	
24																										0.0	
25																										0.0	
26																										0.0	
27																										0.0	
28																								1.5	1.0	2.5	
29	5.0		0.5																							5.5	
30																										0.0	
31																										0.0	
Sub Total																										8.0	
Total																										56.5	

August, 1993		Precipitation per Hour																								Observatory Criva	
Day/Time	1	2	3	4	5	6	7	8	9	10	11	12	13	14	15	16	17	18	19	20	21	22	23	24	Total	Remarks	
1	-	-	-	-	-	-	-	-	-	-	-	-	-	-	-	-	-	-	-	-	-	-	-	-	0.0		
2	-	-	-	-	-	-	-	-	-	-	-	-	-	-	-	-	-	-	-	-	-	-	-	-	0.0		
3	-	-	-	-	-	-	-	-	-	-	-	-	-	-	-	-	-	-	-	-	-	-	-	-	0.0		
4	-	-	-	-	-	-	-	-	-	-	-	-	-	-	-	-	-	-	-	-	-	-	-	-	0.0		
5	-	-	-	-	-	-	-	-	-	-	-	-	-	-	-	-	-	-	-	-	-	-	-	-	0.0		
6	-	-	-	-	-	-	-	-	15.0	1.0	-	-	-	-	-	-	-	-	-	-	-	-	-	-	16.0		
7	-	-	-	-	-	-	-	-	-	-	-	-	-	-	-	-	-	-	-	-	-	-	-	-	0.0		
8	-	-	-	-	-	-	-	-	-	-	-	-	-	-	-	-	-	-	-	-	-	-	-	-	0.0		
9	-	-	-	-	-	-	-	-	-	-	-	-	-	-	-	-	-	-	-	-	-	-	-	-	0.0		
10	-	-	-	-	-	-	-	-	-	-	-	-	-	-	-	-	-	-	-	-	-	-	-	-	0.0		
Sub Total																									16.0		
11	-	-	-	-	-	-	-	-	-	-	-	-	-	-	-	-	-	-	-	-	-	-	-	-	0.0		
12	-	-	-	-	-	-	-	-	-	-	-	-	-	-	-	-	-	-	-	-	-	-	-	-	0.0		
13	-	-	-	-	-	-	-	-	-	-	-	-	-	-	-	-	-	-	-	-	-	-	-	-	0.0		
14	-	-	-	-	-	-	-	-	-	-	-	-	-	-	-	-	-	-	-	-	-	-	-	-	0.0		
15	-	-	-	-	-	-	-	-	-	-	-	-	-	-	-	-	-	-	-	-	-	-	-	-	0.0		
16	-	-	-	-	-	-	-	-	-	-	-	-	-	-	-	-	-	-	-	-	-	-	-	-	0.0		
17	-	-	-	-	-	-	-	-	-	-	-	-	-	-	-	-	-	-	-	-	-	-	-	-	0.0		
18	-	-	-	-	-	-	-	-	-	-	-	-	-	-	-	-	-	-	-	-	-	-	-	-	0.0		
19	-	-	-	-	-	-	-	-	-	-	-	-	-	-	-	-	-	-	-	-	-	-	-	-	0.0		
20	-	-	-	-	-	-	-	-	-	-	-	-	-	-	-	-	-	-	-	-	-	-	-	-	0.0		
Sub Total																									0.0		
21	-	-	-	-	-	-	-	-	-	-	-	-	-	-	-	-	-	-	-	-	-	-	-	-	0.0		
22	-	-	-	-	-	-	-	-	-	-	-	-	-	-	-	-	-	-	-	-	-	-	-	-	0.0		
23	-	-	-	-	-	-	-	-	-	-	-	-	-	-	-	-	-	-	-	-	-	-	-	-	0.0		
24	-	-	-	-	-	-	-	-	-	-	-	-	-	-	-	-	-	-	-	-	-	-	-	-	0.0		
25	-	-	-	-	-	-	-	-	-	-	-	-	-	-	-	-	-	-	-	-	-	-	-	-	0.0		
26	-	-	-	-	-	-	-	-	-	-	-	-	-	-	-	-	-	-	-	-	-	-	-	-	0.0		
27	-	-	-	-	-	-	-	-	-	-	-	-	-	-	-	-	-	-	-	-	-	-	-	-	0.0		
28	-	-	-	-	-	-	-	-	-	-	-	-	-	-	-	-	-	-	-	-	1.5	1.5	2.5	5.0	10.5		
29	2.5	5.5	8.5	-	0.5	-	-	-	-	-	-	-	-	-	-	0.5	-	1.5	0.5	0.5	6.5	2.5	-	0.5	29.5		
30	1.0	-	-	-	-	-	-	-	-	-	-	-	-	-	-	-	-	-	-	-	-	-	-	-	1.0		
31	-	-	-	-	-	-	-	-	-	-	-	-	-	-	-	-	-	-	-	-	-	-	-	-	0.0		
Sub Total																									41.0		
Total																									57.0		

September, 1993		Precipitation per Hour																								Observatory Criva	
Day/Time	1	2	3	4	5	6	7	8	9	10	11	12	13	14	15	16	17	18	19	20	21	22	23	24	Total	Remarks	
1	-	-	-	-	-	-	-	-	-	-	-	-	-	-	-	-	-	-	-	-	-	-	-	-	0.0		
2	-	-	-	-	-	-	-	-	-	-	-	-	-	-	-	-	-	-	-	-	-	-	-	-	0.0		
3	-	-	-	-	-	-	-	-	-	-	-	-	-	-	-	-	-	-	-	-	-	-	-	-	0.0		
4	-	-	-	-	-	-	-	-	-	-	-	3.0	1.0	1.5	-	-	1.0	-	-	-	-	1.0	-	-	7.5		
5	-	-	-	-	-	-	-	-	-	-	-	-	-	-	-	-	-	-	-	-	-	-	-	-	0.0		
6	-	-	-	-	-	-	-	-	-	-	-	0.5	-	-	1.5	3.0	2.0	-	0.5	-	-	-	-	-	7.5		
7	-	-	-	-	0.5	4.0	5.0	2.5	-	-	0.5	0.5	-	-	-	-	-	-	-	-	-	-	-	-	13.0		
8	-	-	-	-	-	-	-	-	-	-	-	-	-	-	-	-	-	-	-	-	-	-	-	-	0.0		
9	-	-	-	-	-	-	-	-	0.5	0.5	0.5	-	-	1.0	0.5	0.5	-	-	-	-	0.5	-	-	-	4.0		
10	-	-	-	-	-	-	-	-	-	-	-	-	-	-	-	-	-	-	-	-	-	-	-	-	0.0		
Sub Total																									32.0		
11	-	-	-	-	-	-	-	-	-	-	-	-	-	-	-	-	-	-	-	-	-	-	-	-	0.0		
12	-	-	-	-	-	-	-	-	-	-	-	-	-	-	-	-	-	-	-	-	-	-	-	-	0.0		
13	-	-	-	-	-	-	-	-	1.0	3.0	0.5	-	-	-	0.5	-	-	1.0	-	-	-	-	-	-	6.0		
14	-	-	-	-	-	-	-	-	1.0	0.5	0.5	-	1.0	0.5	1.5	-	-	-	-	-	-	-	-	-	5.0		
15	-	-	-	-	-	-	-	-	-	-	-	-	-	-	-	-	-	-	-	-	-	-	-	-	0.0		
16	-	-	-	-	-	-	-	-	-	-	-	-	-	-	-	-	-	-	-	-	-	-	-	-	0.0		
17	-	-	-	-	-	-	-	-	-	-	-	-	-	-	-	-	-	-	-	-	-	-	-	-	0.0		
18	-	-	-	-	-	-	1.0	2.0	2.0	1.0	0.5	0.5	-	-	-	-	-	-	-	-	-	-	-	-	7.0		
19	-	-	-	-	-	-	-	-	-	-	-	-	-	-	-	-	-	-	-	-	-	-	-	-	0.0		
20	-	0.5	-	-	1.5	1.0	3.5	4.0	3.5	2.5	2.0	0.5	-	-	-	-	-	0.5	1.0	1.5	1.0	0.5	0.5	1.0	25.0		
Sub Total																									45.5		
21	1.0	1.0	0.5	1.5	3.5	1.0	-	-	-	-	0.5	-	-	-	-	-	-	-	-	-	-	-	-	-	9.0		
22	-	-	-	-	-	-	-	-	-	-	-	-	-	-	-	-	-	-	-	-	-	-	-	-	0.0		
23	-	-	-	-	-	-	-	-	-	-	-	-	-	-	-	-	-	-	-	-	-	-	-	-	0.0		
24	-	-	-	-	-	-	-	-	-	-	-	-	-	-	-	-	-	-	-	-	-	-	-	-	0.0		
25	-	-	-	-	-	-	-	-	-	-	-	-	-	-	-	-	-	-	-	-	-	-	-	-	0.0		
26	-	-	-	-	-	-	-	-	-	-	-	-	-	-	-	-	-	-	-	-	-	-	-	-	0.0		
27	-	-	-	-	-	-	-	-	-	-	-	-	-	-	-	-	-	-	-	-	-	-	-	-	0.0		
28	-	-	-	-	-	-	-	-	-	0.5	0.5	-	-	-	1.0	2.5	-	-	-	-	-	-	-	-	4.5		
29	-	-	-	-	-	-	-	-	-	-	-	-	-	-	-	-	-	-	-	-	-	-	-	-	0.0		
30	-	-	-	-	-	-	-	-	-	-	-	-	-	-	-	-	-	-	-	-	-	-	-	-	0.0		
31	-	-	-	-	-	-	-	-	-	-	-	-	-	-	-	-	-	-	-	-	-	-	-	-	0.0		
Sub Total																									13.5		
Total																									91.0		

October, 1993																								Precipitation per Hour				Observatory Criva	
Day/Time	1	2	3	4	5	6	7	8	9	10	11	12	13	14	15	16	17	18	19	20	21	22	23	24	Total	Remarks			
1	-	-	-	-	-	-	-	-	-	-	-	-	-	-	-	-	-	-	-	-	-	-	-	-	0.0				
2	-	-	-	-	-	-	-	-	-	-	-	-	-	-	-	-	-	-	-	-	-	-	-	-	-	0.0			
3	1.5	2.0	-	0.5	0.5	1.5	0.5	0.5	-	0.5	-	0.5	2.5	1.5	-	1.5	-	0.5	-	-	-	-	-	0.5	14.5				
4	-	-	-	-	-	-	-	0.5	-	-	-	-	-	-	-	-	-	-	-	-	-	-	-	-	-	0.5			
5	-	-	-	-	-	-	-	-	-	-	-	-	-	-	-	-	-	-	-	-	-	-	-	-	-	0.0			
6	-	-	-	-	-	-	-	-	-	-	-	-	-	-	-	-	-	-	-	-	-	-	-	-	-	0.0			
7	-	-	-	-	-	-	-	-	-	-	-	-	-	-	-	-	-	-	-	-	-	-	-	-	-	0.0			
8	1.0	1.5	-	-	-	0.5	-	-	0.5	-	-	-	-	-	-	-	-	-	-	-	-	-	-	-	-	3.5			
9	-	-	-	-	-	-	-	-	-	-	-	-	-	-	-	-	-	-	-	-	-	-	-	-	-	0.0			
10	-	-	-	-	-	-	-	-	-	-	-	0.5	-	-	-	-	-	-	-	-	-	-	-	-	-	0.5			
Sub Total																								19.0					
11	-	-	-	-	-	-	-	-	-	-	-	-	-	-	-	-	-	-	-	-	-	-	-	-	-	0.0			
12	-	-	-	-	-	-	-	-	-	-	-	-	-	-	-	-	-	-	-	-	-	2.0	0.5	1.5	-	4.0			
13	1.0	-	-	0.5	2.5	1.0	1.0	1.5	2.5	1.5	0.5	-	-	2.0	1.0	2.5	-	-	-	-	-	-	-	-	0.5	18.0			
14	-	-	-	-	-	-	-	-	-	-	-	-	0.5	-	0.5	-	-	-	-	-	-	-	-	-	-	-	1.0		
15	-	-	-	-	-	-	-	-	-	-	-	-	-	-	-	-	-	-	-	-	-	-	-	-	-	-	0.0		
16	-	-	-	-	-	-	-	-	-	-	-	-	-	-	-	-	-	-	-	-	-	-	-	-	-	-	0.0		
17	-	-	-	-	-	-	-	-	-	-	-	-	-	-	-	-	-	-	-	-	-	-	-	-	-	-	0.0		
18	-	-	-	-	-	-	-	-	-	-	-	-	-	-	-	-	-	-	-	-	-	-	-	-	-	-	0.0		
19	-	-	-	-	-	-	-	-	-	-	-	-	-	-	-	-	-	-	-	-	-	-	-	-	-	-	0.0		
20	-	-	-	-	-	-	-	-	-	-	-	-	-	-	-	-	-	-	-	-	-	-	-	-	-	-	0.0		
Sub Total																								23.0					
21	1.0	-	-	-	-	-	-	-	-	-	-	-	-	-	-	-	-	-	-	-	-	-	-	-	-	-	1.0		
22	-	-	-	-	-	-	-	-	-	-	-	-	-	-	-	-	-	-	-	-	-	-	-	-	-	-	0.0		
23	-	-	-	-	-	-	-	-	-	-	-	-	-	-	-	-	-	-	-	-	-	-	-	-	-	-	0.0		
24	-	-	-	-	-	-	-	-	-	-	-	-	-	-	-	-	-	-	-	-	-	-	-	-	-	-	0.0		
25	-	-	-	-	-	-	-	-	-	-	-	-	-	-	-	-	-	-	-	-	-	-	-	-	-	-	0.0		
26	-	-	-	-	-	0.5	1.5	2.0	0.5	1.5	-	-	-	-	-	-	-	-	-	-	-	-	-	-	-	-	6.0		
27	-	-	-	-	-	-	-	-	-	-	-	-	-	-	-	-	-	-	-	-	-	-	-	-	-	-	0.0		
28	-	-	-	-	-	-	-	-	-	-	-	-	-	-	-	-	-	-	-	-	-	-	-	-	-	-	0.0		
29	-	-	-	-	-	-	-	-	-	-	-	-	-	-	-	-	-	-	-	-	-	-	-	-	-	-	0.0		
30	-	-	-	-	-	-	-	-	-	-	-	-	-	-	-	-	-	-	-	-	-	-	-	-	-	-	0.0		
31	-	-	-	-	-	-	-	-	-	-	-	-	-	-	-	-	-	-	-	-	-	-	-	-	-	-	0.0		
Sub Total																								7.0					
Total																								49.0					

November, 1993																								Precipitation per Hour				Observatory Criva	
Day/Time	1	2	3	4	5	6	7	8	9	10	11	12	13	14	15	16	17	18	19	20	21	22	23	24	Total	Remarks			
1	-	-	-	-	-	-	-	-	-	-	-	-	-	-	-	-	-	-	-	-	-	-	-	-	-	-	0.0		
2	-	-	-	-	-	-	-	-	0.5	-	-	-	-	-	-	-	-	-	-	-	-	-	-	-	-	-	0.5		
3	-	-	-	-	-	-	-	-	-	-	-	-	-	-	-	-	-	-	-	-	-	-	-	-	-	-	0.0		
4	-	-	-	-	-	-	-	-	-	-	-	-	-	-	-	-	-	-	-	-	-	-	-	-	-	-	0.0		
5	-	-	-	-	-	-	-	-	-	-	-	-	-	-	-	-	-	-	-	-	-	-	-	-	-	-	0.0		
6	-	-	-	-	-	-	-	-	-	-	-	-	-	-	-	-	-	-	-	-	-	0.5	-	-	-	-	0.5		
7	-	0.5	-	-	-	-	-	-	-	-	-	-	-	-	-	-	-	-	-	-	-	-	-	-	-	-	0.5		
8	-	-	-	-	-	-	-	-	-	-	-	-	-	-	-	-	-	-	-	-	-	-	-	-	-	-	0.0		
9	-	-	-	-	-	-	-	-	-	-	-	-	-	-	-	-	-	-	-	-	-	-	-	-	-	-	0.0		
10	-	-	-	-	-	-	-	-	-	-	-	-	-	-	-	-	-	-	-	-	-	-	-	-	-	-	0.0		
Sub Total																								1.5					
11	-	-	-	-	-	-	-	-	0.5	1.5	-	-	0.5	0.5	0.5	-	-	-	-	-	-	-	-	-	0.5	3.5			
12	-	0.5	-	0.5	1.0	-	1.0	1.0	0.5	-	0.5	1.0	0.5	0.5	0.5	-	-	0.5	-	-	-	-	-	-	-	-	8.0		
13	-	-	-	-	-	-	-	-	-	-	-	-	-	-	-	-	-	-	0.5	-	-	-	-	-	-	-	0.5		
14	-	-	-	-	-	-	-	-	-	-	-	-	-	-	-	-	-	-	-	-	-	-	-	-	-	-	0.0		
15	-	-	-	-	-	-	-	-	-	-	-	-	0.5	2.5	1.0	-	-	-	-	-	-	-	-	-	-	-	7.0		
16	-	-	-	-	-	-	-	-	-	-	-	-	-	-	-	-	-	-	-	-	-	-	-	-	-	-	0.0		
17	-	-	-	-	-	-	-	-	-	-	-	-	-	-	-	-	-	-	-	-	-	-	-	-	-	-	0.0		
18	-	-	-	-	-	-	-	-	-	-	-	-	-	-	-	-	-	-	-	-	-	-	-	-	-	-	0.0		
19	-	-	-	-	-	-	-	-	-	-	-	-	-	-	-	-	-	-	-	-	-	-	-	-	-	-	0.0		
20	-	-	-	-	-	-	-	-	-	-	-	0.5	-	-	-	-	-	-	-	-	-	-	-	-	-	-	0.5		
Sub Total																								19.5					
21	-	-	-	-	-	-	-	-	-	-	-	-	-	-	-	-	-	-	-	-	-	-	-	-	-	-	0.0		
22	-	-	-	-	-	-	-	-	-	-	-	-	-	-	-	-	-	-	-	-	-	-	-	-	-	-	0.0		
23	-	-	-	-	-	-	-	-	-	-	-	-	-	-	-	-	-	-	-	-	-	-	-	-	-	-	0.0		
24	-	-	-	-	-	-	-	-	-	-	-	-	-	-	-	-	-	-	-	-	-	-	-	-	-	-	0.0		
25	-	-	-	-	-	-	-	-	-	-	-	-	0.5	-	-	-	-	-	-	-	-	-	-	-	-	-	0.5		
26	-	-	-	-	-	-	-	-	-	-	-	-	-	-	-	-	-	-	-	-	-	-	-	-	-	-	0.0		
27	-	-	-	-	-	-	-	-	-	-	-	-	-	-	-	-	-	-	-	-	-	-	-	-	-	-	0.0	Stop observing	
28	-	-	-	-	-	-	-	-	-	-	-	-	-	-	-	-	-	-	-	-	-	-	-	-	-	-	0.0		
29	-	-	-	-	-	-	-	-	-	-	-	-	-	-	-	-	-	-	-	-	-	-	-	-	-	-	0.0		
30	-	-	-	-	-	-	-	-	-	-	-	-	-	-	-	-	-	-	-	-	-	-	-	-	-	-	0.0		
31	-	-	-	-	-	-	-	-	-	-	-	-	-	-	-	-	-	-	-	-	-	-	-	-	-	-	0.0		
Sub Total																								0.5					
Total																								21.5					

March, 1999		Precipitation per Hour																								Observatory Criva		
Day/Time	1	2	3	4	5	6	7	8	9	10	11	12	13	14	15	16	17	18	19	20	21	22	23	24	Total	Remarks		
1																										0.0		
2																											0.0	
3																											0.0	
4																											0.0	
5																											0.0	
6																											0.0	
7																											0.0	
8																											0.0	
9																											0.0	
10																											0.0	
Sub Total																											0.0	
11																											0.0	
12																											0.0	
13																											0.0	
14																											0.0	
15																											0.0	Start of observation
16																											0.0	
17																											0.0	
18																											0.0	
19																											0.0	
20																											0.0	
Sub Total																											0.0	
21																											0.0	
22																											0.0	
23																											0.0	
24																											0.0	
25																											0.0	
26																											0.0	
27																											0.0	
28						1.0	1.5	1.0										0.5		0.5			0.5				5.0	
29								0.5												0.5							1.0	
30							0.5																	0.5			1.0	
31					0.5					0.5																	1.0	
Sub Total																											8.0	
Total																											8.0	

April, 1999		Precipitation per Hour																								Observatory Criva		
Day/Time	1	2	3	4	5	6	7	8	9	10	11	12	13	14	15	16	17	18	19	20	21	22	23	24	Total	Remarks		
1																											0.0	
2																	0.5	0.5	0.5								1.5	
3					0.5																						0.5	
4	0.5																										0.5	
5																											0.0	
6																											0.0	
7																											0.0	
8																											0.0	
9																											0.0	
10																						2.5					2.5	
Sub Total																											5.0	
11																											0.0	
12																											0.0	
13																		3.0									3.0	
14			0.5																								0.5	
15																											0.0	
16																											0.0	
17						0.5	0.5	1.0			1.0	0.5				7.0											10.5	
18																						0.5					0.5	
19																											0.0	
20													0.5														0.5	
Sub Total																											15.0	
21																											0.0	
22																											0.0	
23														1.0	1.0	1.0	2.0	2.0	1.5	0.5	0.5						9.5	
24								3.0	2.5	5.5	2.0																13.0	
25					11.0	1.0	0.5	0.5	0.5										0.5	0.5	2.5						17.5	
26	2.5	3.5	1.5	0.5		4.5	1.5														0.5	1.0	0.5				16.5	
27	1.0	5.5	2.5	0.5																							9.5	
28																											0.0	
29																											0.0	
30																											0.0	
31																											0.0	
Sub Total																											66.0	
Total																											86.0	

May, 1999		Precipitation per Hour																								Observatory	Criva	Total	Remarks
Day/Time	1	2	3	4	5	6	7	8	9	10	11	12	13	14	15	16	17	18	19	20	21	22	23	24					
1	1.5	0.5	-	-	-	-	-	-	-	-	-	-	-	-	-	-	-	-	-	-	-	-	-	-	-	-	2.0		
2	-	-	-	-	-	-	-	-	-	-	-	-	-	-	-	-	-	-	-	-	-	-	-	-	-	-	0.0		
3	-	-	-	-	-	-	-	-	-	-	-	-	-	-	-	-	-	-	-	-	-	-	-	-	-	-	0.0		
4	-	-	-	-	-	-	-	-	-	-	-	-	-	-	-	-	-	-	-	-	-	-	-	-	-	-	0.9		
5	-	-	-	-	-	-	-	-	-	-	-	-	-	-	-	-	-	-	-	-	-	-	-	-	-	0.5			
6	0.5	1.5	-	0.5	-	0.5	-	0.5	-	0.5	-	-	-	-	0.5	-	-	-	-	-	-	-	-	-	-	0.5	1.0		
7	-	-	-	-	-	-	-	-	-	-	-	-	-	-	-	-	-	-	-	-	-	-	-	-	-	-	4.5		
8	-	-	-	-	-	-	-	-	-	-	-	-	-	-	-	-	-	-	-	-	-	-	-	-	-	-	0.0		
9	-	-	-	-	-	-	-	-	-	-	-	-	-	-	-	-	-	-	-	-	-	-	-	-	-	-	0.0		
10	0.5	-	1.5	1.0	-	-	-	-	-	0.5	-	-	-	-	-	-	-	-	-	-	-	-	-	-	-	-	3.5		
Sub Total																									11.5				
11	-	-	-	-	-	-	-	-	-	-	-	-	-	-	-	-	-	-	-	-	-	-	-	-	-	-	0.0		
12	-	-	-	-	-	-	-	-	-	-	-	-	-	-	-	-	-	-	-	-	-	-	-	-	-	-	0.0		
13	-	-	-	-	-	-	-	-	-	-	-	0.5	0.5	1.5	-	-	-	-	-	-	-	-	-	-	-	-	2.5		
14	-	-	-	-	-	-	-	-	-	-	-	-	-	-	-	-	-	-	-	-	-	-	-	-	-	-	19.5		
15	-	-	5.5	-	0.5	-	-	-	-	-	-	-	-	-	-	-	-	-	-	-	-	-	-	-	4.5	5.5	9.5	6.0	
16	-	-	-	-	-	-	-	-	-	-	-	-	-	-	-	-	-	-	-	-	-	-	-	-	-	-	0.5		
17	-	-	-	-	-	-	-	0.5	-	-	-	-	-	-	-	-	-	-	-	-	-	-	-	-	-	-	0.5		
18	-	-	-	-	-	-	-	-	-	-	-	-	-	1.5	-	0.5	-	-	-	-	-	-	-	-	-	-	2.0		
19	-	-	-	-	-	-	-	-	-	-	-	-	-	-	-	-	-	-	-	-	-	-	-	-	-	-	0.0		
20	-	-	-	-	-	-	-	-	-	-	-	-	-	-	-	-	-	-	-	-	-	-	-	-	-	-	0.0		
Sub Total																									31.0				
21	-	-	-	-	-	-	-	-	-	-	-	-	-	-	-	-	-	-	-	-	-	-	-	-	-	-	0.0		
22	-	-	-	-	-	-	-	3.0	4.0	-	-	-	-	-	-	-	-	-	-	-	-	-	-	-	-	-	7.0		
23	-	-	-	-	-	-	-	-	-	-	-	-	-	-	-	-	-	-	-	-	-	-	-	-	-	-	6.0		
24	-	-	-	-	-	-	-	-	-	-	-	-	0.5	-	-	-	-	-	-	-	-	-	-	-	-	-	0.5		
25	-	-	-	-	-	-	-	-	-	-	-	-	-	-	-	-	-	-	-	-	-	-	-	-	-	-	0.0		
26	-	-	-	-	-	-	-	-	-	-	-	-	-	-	-	-	-	-	-	-	-	-	-	-	-	-	0.0		
27	-	-	-	-	-	-	-	-	-	-	-	-	-	-	-	-	-	-	-	-	-	-	-	-	-	-	0.0		
28	-	-	-	-	-	-	-	-	-	-	-	-	-	-	-	-	-	-	-	-	-	-	-	-	-	-	0.0		
29	-	-	-	-	-	-	-	-	-	-	-	-	-	-	-	-	-	-	-	-	-	-	-	-	-	-	0.0		
30	-	-	-	-	-	-	-	-	-	-	-	-	-	-	-	-	-	-	-	-	-	-	-	-	-	-	0.0		
31	-	-	-	-	-	-	-	-	-	-	-	-	-	-	-	-	-	-	-	-	-	-	-	-	-	-	0.0		
Sub Total																									13.5				
Total																									56.0				

## Appendix A-5 Precipitation and Water Suction

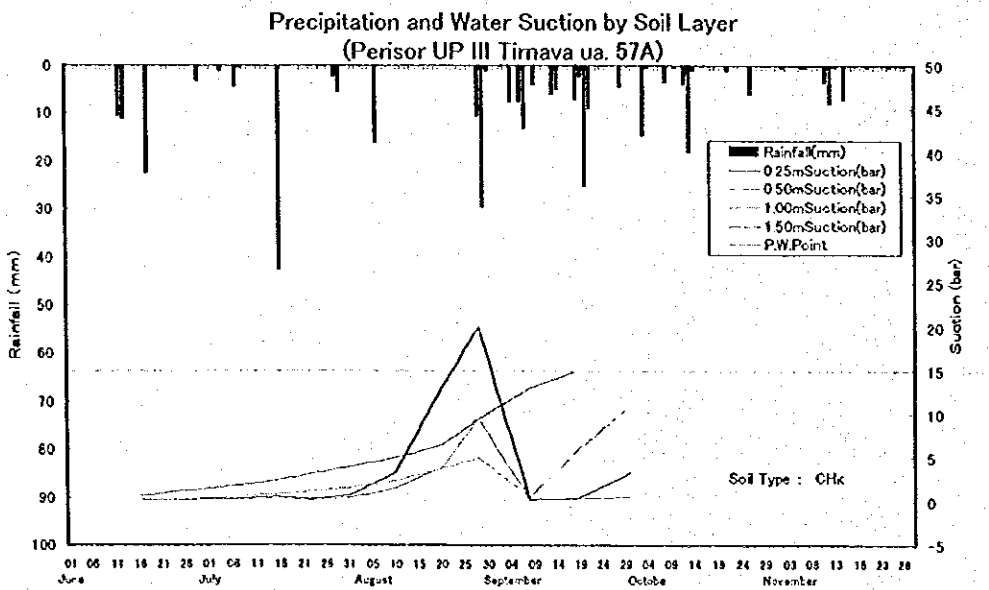
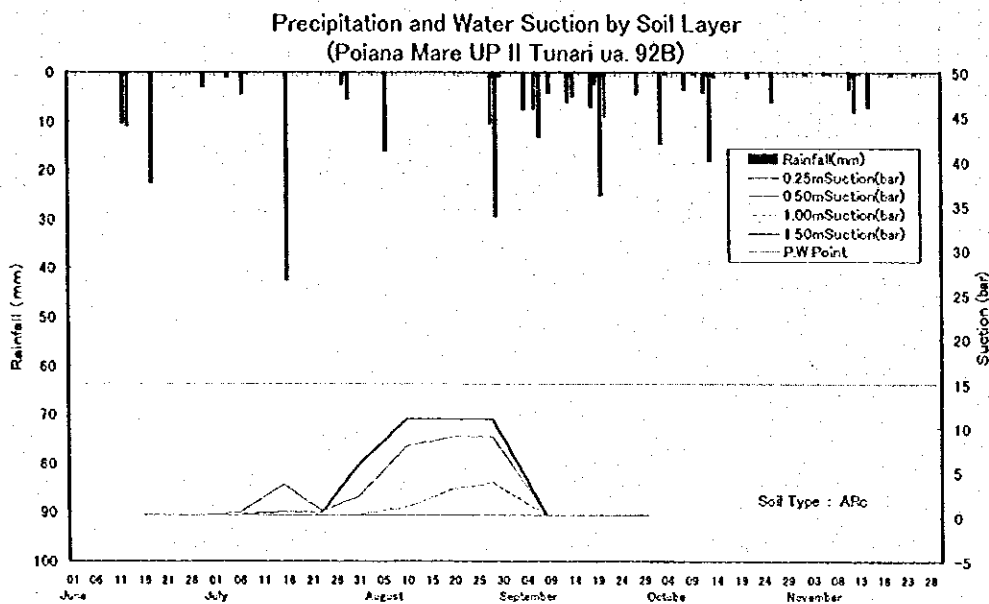
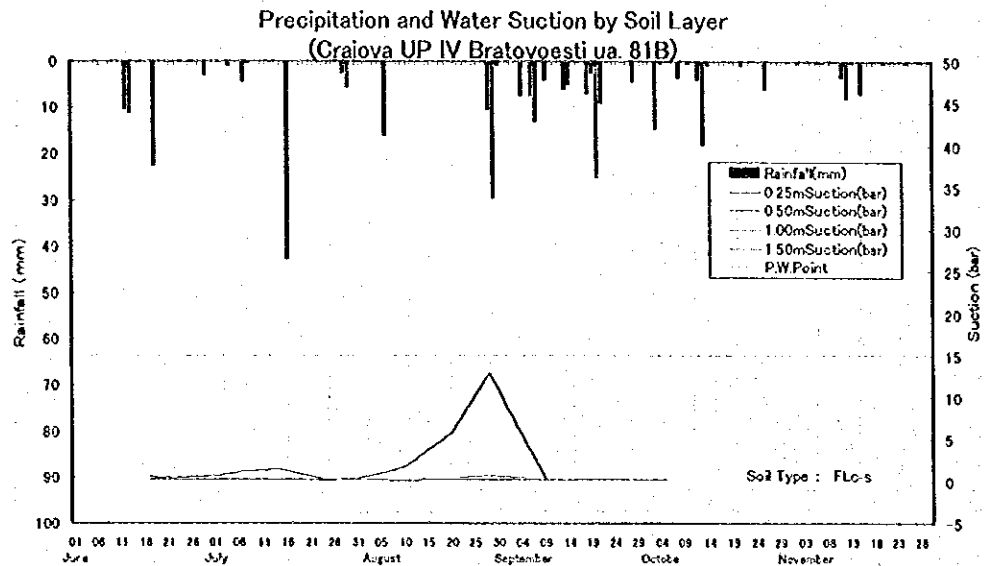

Precipitation and Water Suction by Soil Layer  
(Craiova UP I Criva ua. 80)

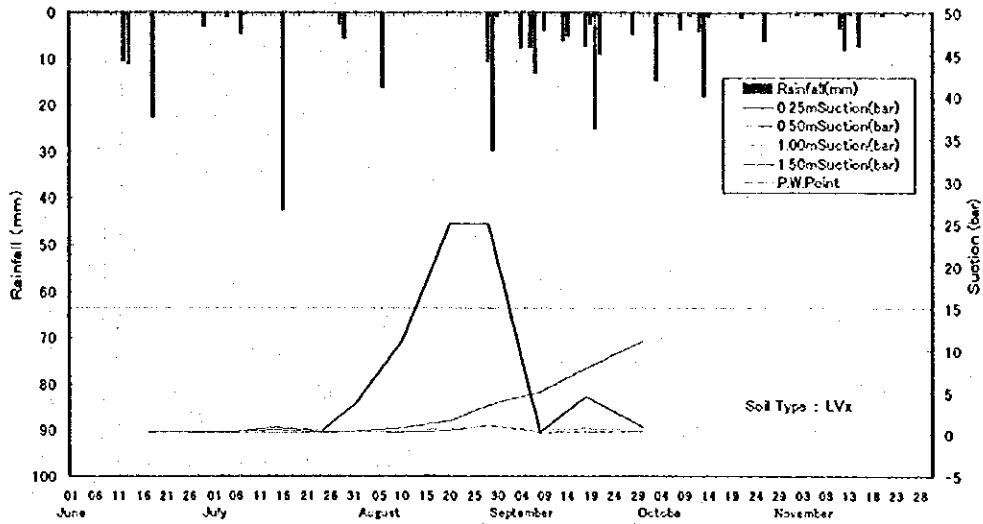

Precipitation and Water Suction by Soil Layer  
(Perisor UP I Verbicioara ua. 64A)

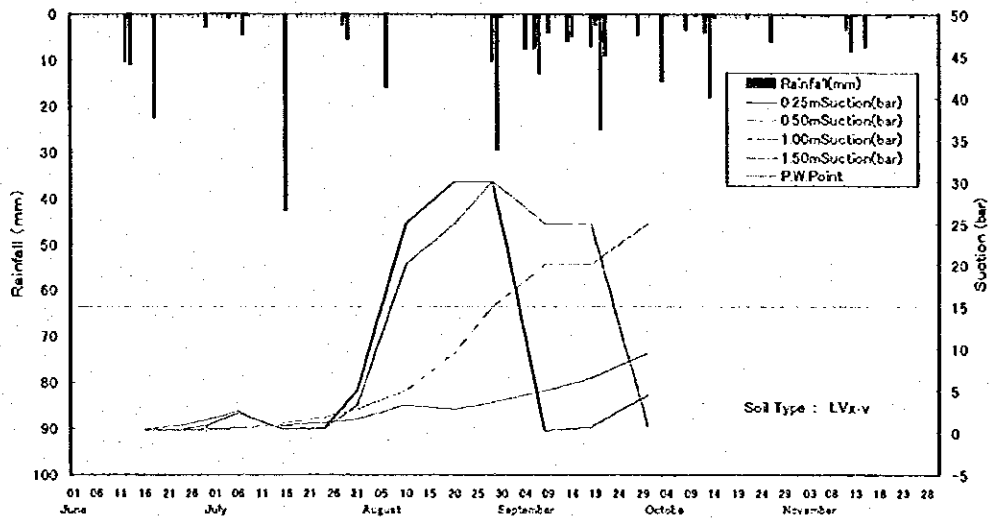

Precipitation and Water Suction by Soil Layer  
(Craiova UP III Seaca ua. 95A)

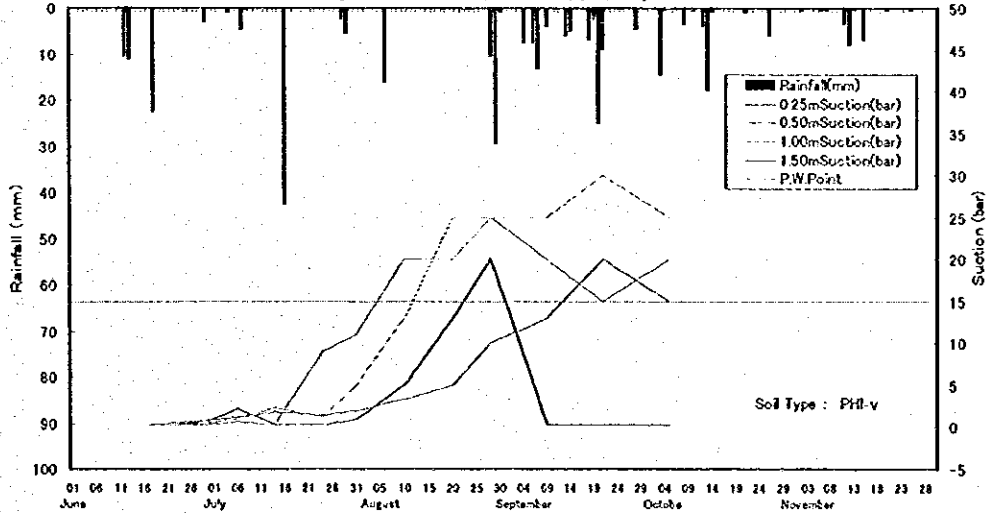

Precipitation and Water Suction by Soil Layer  
(Craiova UP III Seaca ua. 46A)

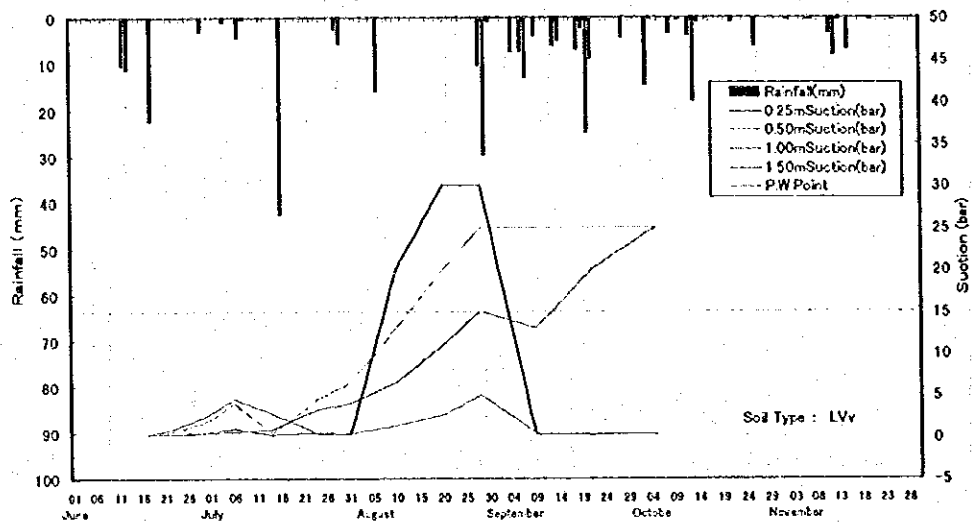



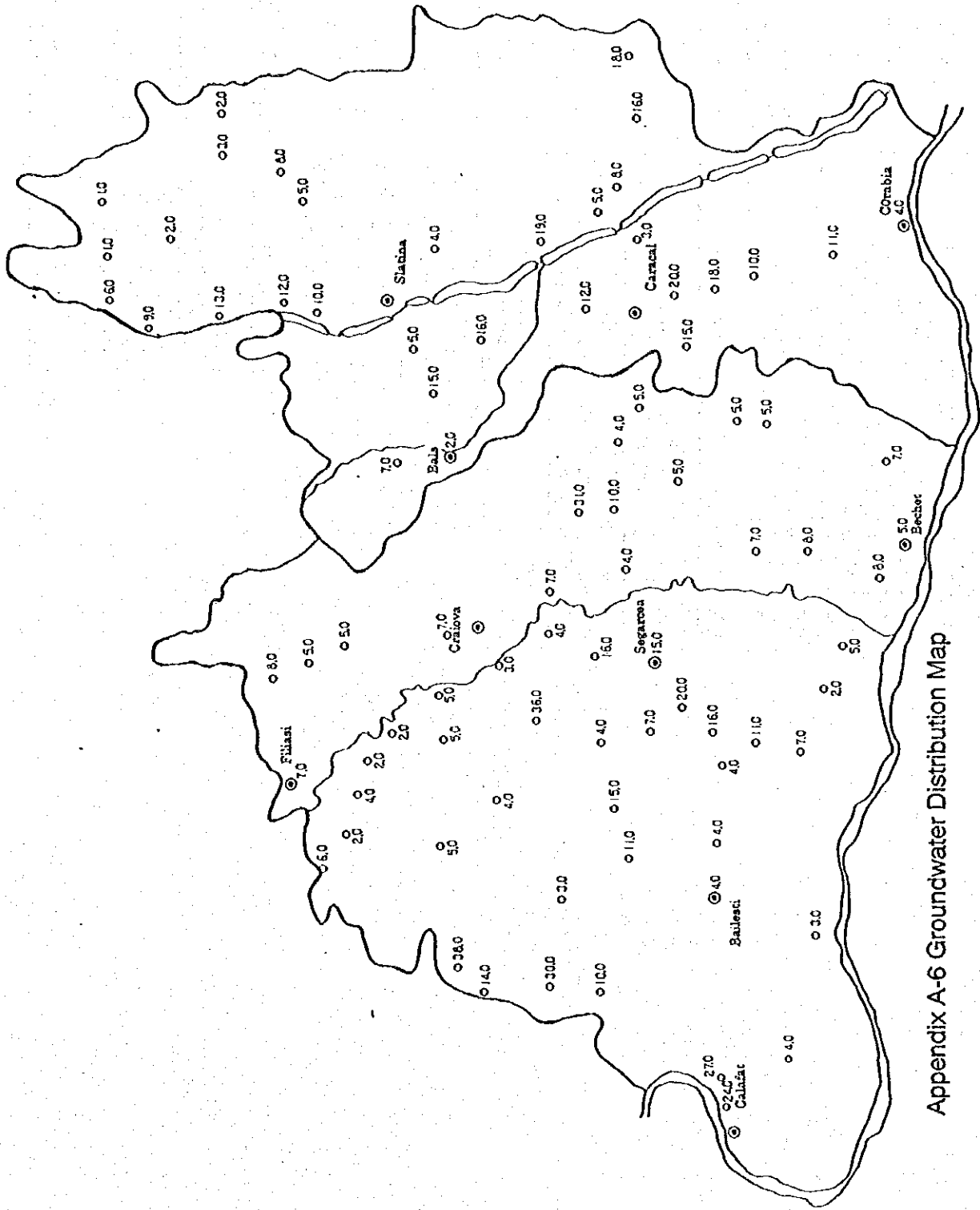

Appendix A-6 Groundwater Distribution Map

Appendix A-7 Soil porosity ratio on each study point

Items	Study Point								
	Slatina UP III, ua.95a			Craiova UP I, ua.80			Craiova UP IV, ua.81B		
Sample Depth (cm)	15	50	80	15	50	80	10	45	80
pF0.7 Porosity Ratio (%)	5.3	0.4	0.5	0.8	0.4	0.6	1.3	2.2	3.9
pF1.7 Porosity Ratio (%)	7.3	0.6	0.7	1.2	0.6	0.8	1.6	3.0	4.5
pF2.7 Porosity Ratio (%)	15.2	3.0	4.2	5.9	3.0	3.3	5.3	9.5	10.6
pF4.0 Porosity Ratio (%)	35.1	21.6	22.1	32.2	19.6	20.0	45.2	40.3	39.1

Items	Study Point								
	Slatina UP III, ua.46a			Perisor UP I, ua.114A			Perisor UP III, ua.57A		
Sample Depth (cm)	15	50	90	15	45	80	15	50	80
pF0.7 Porosity Ratio (%)	4.8	2.0	1.2	4.6	1.7	1.9	1.8	1.0	1.4
pF1.7 Porosity Ratio (%)	5.9	2.6	1.7	5.9	1.8	2.2	2.6	1.1	2.0
pF2.7 Porosity Ratio (%)	11.7	8.4	6.1	12.9	5.8	5.7	7.2	3.6	6.2
pF4.0 Porosity Ratio (%)	42.6	40.9	38.8	39.6	27.1	27.2	39.7	20.8	27.1

Items	Study Point	
	Poiana Mare UP III, ua.15A	
Sample Depth (cm)	15	80
pF0.7 Porosity Ratio (%)	16.1	8.5
pF1.7 Porosity Ratio (%)	18.0	8.9
pF2.7 Porosity Ratio (%)	27.5	14.0
pF4.0 Porosity Ratio (%)	47.5	40.1

## Appendix B 土壤

---

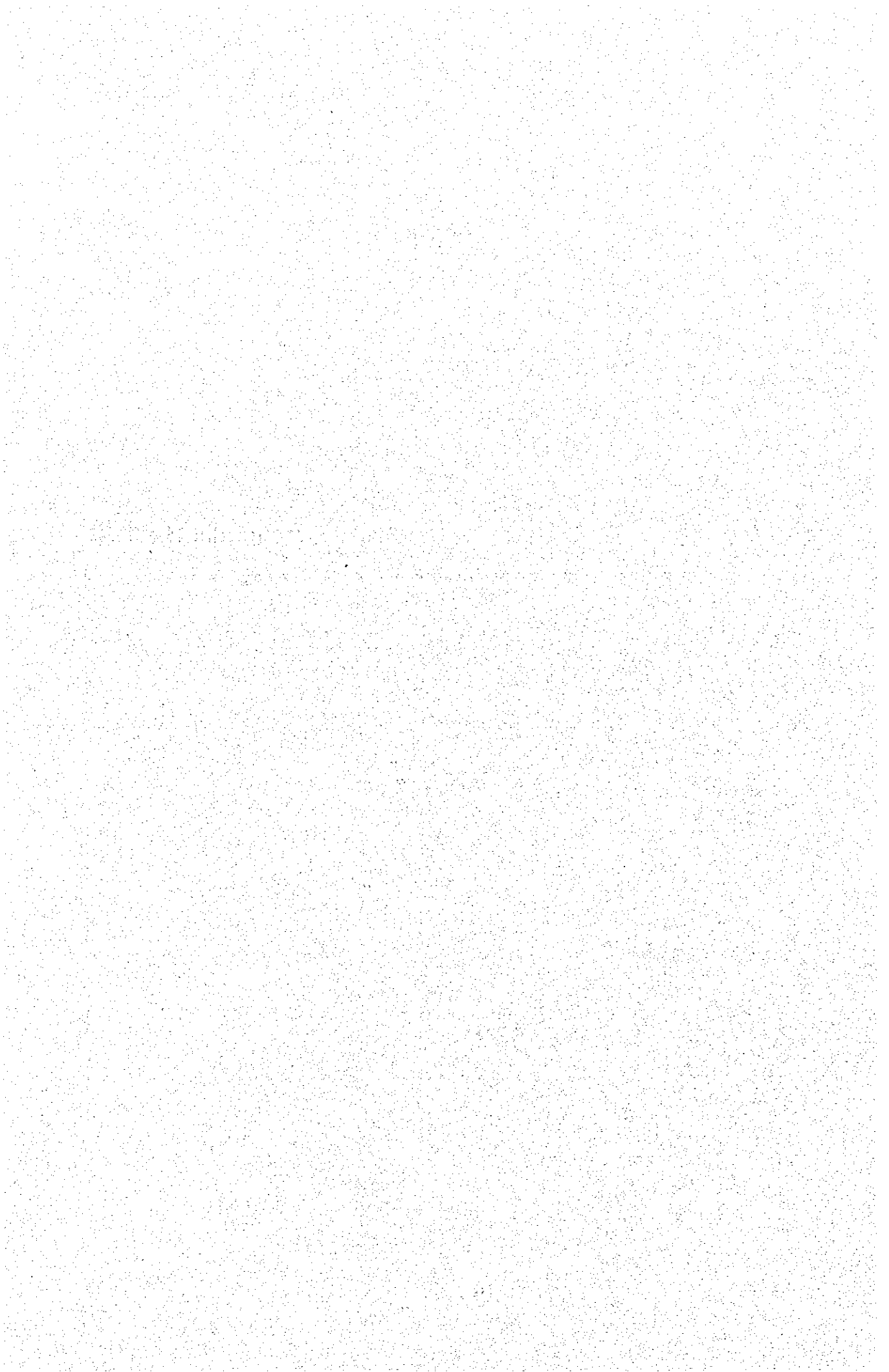

## Appendix B: 土壤

### Appendix B-1 Positions of Soil Profile Points

Profile No.	Location		Position	
	Ocol Silvic	UP, ua.	Longitude	Latitude
Dolj No. 1	CRAIOVA	UP III, ua. 95A (Seaca)	44° 21.332 N	23° 18.051 E
Dolj No. 2	CRAIOVA	UP I, ua. 80 (Criva)	44° 15.862 N	23° 38.522 E
Dolj No. 3	CRAIOVA	UP I, ua. 90 (Criva)	44° 15.706 N	23° 38.764 E
Dolj No. 4	CRAIOVA	UP II, ua. 62G (Bucovat)	44° 17.312 N	23° 42.462 E
Dolj No. 5	CRAIOVA	UP IV, ua. 144A (Cosoveni)	44° 13.685 N	23° 56.051 E
Dolj No. 6	CRAIOVA	UP IV, ua. 81B (Bratovoesti)	44° 06.059 N	23° 54.290 E
Dolj No. 7	AMARADIA	UP III, ua. 114B (Barota)	44° 43.756 N	23° 46.514 E
Dolj No. 8	CRAIOVA	UP III, ua. 46A (Seaca)	44° 23.035 N	23° 12.811 E
Dolj No. 9	PERISOR	UP I, ua. 114A (Verbicioara)	44° 17.560 N	23° 12.916 E
Dolj No. 10	PERISOR	UP I, ua. 119A (Verbicioara)	44° 17.095 N	23° 13.239 E
Dolj No. 11	PERISOR	UP III, ua. 57A (Timava)	44° 08.549 N	23° 32.021 E
Dolj No. 12	PERISOR	UP II, ua. 27A (Lzvoare, Rudari)	44° 09.081 N	23° 19.306 E
Dolj No. 13	POIANA MARE	UP III, ua. 15A (Pisculet)	43° 50.226 N	23° 08.863 E
Dolj No. 14	POIANA MARE	UP III, ua. 11B (Pisculet)	43° 50.026 N	23° 08.490 E
Dolj No. 15	APELE VII	UP II, ua. 75C (Apele Vii)	44° 02.737 N	24° 03.429 E
Dolj No. 16	APELE VII	UP II, ua. 42C (Apele Vii)	44° 02.620 N	24° 01.752 E
Dolj No. 17	SEGARCEA	UP III, ua. 72A (Radovan, Desnatui)	44° 09.256 N	23° 36.290 E
Dolj No. 18	SEGARCEA	UP III, ua. 84A (Radovan, Desnatui)	44° 08.919 N	23° 37.654 E
Dolj No. 19	SADOVA	UP III, ua. 11A (Zaval, Lunca Jiu)	43° 49.485 N	23° 52.519 E
Dolj No. 20	AMARADIA	UP II, ua. 37D (Farcasu)	44° 38.991 N	23° 44.604 E
Olt No. 1	CARACAL	UP III, ua. 52A (Resca)	44° 11.210 N	24° 25.259 E
Olt No. 2	BALS	UP V, ua. 100 (Bistrita)	44° 21.943 N	24° 11.401 E
Olt No. 3	BALS	UP V, ua. 145 (Saru)	44° 25.406 N	24° 11.579 E
Olt No. 4	VULTURESTI	UP I, ua. 98D (Dumitresti)	44° 37.169 N	24° 23.545 E
Olt No. 5	SLATINA	UP V, ua. 37A (Seaca)	44° 42.597 N	24° 28.257 E
Olt No. 6	SLATINA	UP IV OPORELU, ua. 123 (Ghiteasca)	44° 33.581 N	24° 34.333 E
Olt No. 7	SLATINA	UP IV OPORELU, ua. 151A (Corbu, Sinesti)	44° 28.582 N	24° 41.332 E
Olt No. 8	CARACAL	UP I, ua. 35 (Vladila)	44° 00.195 N	24° 22.461 E

Appendix B-2 Soil Profile Points and Soil Classification

Profile No.	Location Ocol Silvic, UP, ua.	Vegetation	Soil Classification	
			SRCS	FAO/UNESCO
Dolj No. 1	CRAIOVA UP III, ua. 95A (Seaca)	<i>Q. frainetto</i> 98% <i>Q. cerris</i> 2% 60 y	BDmo-vs Sol brun argiloiluvial molie-vertic	PHI-v Vertic-Luvic Phaeozems (weak luvic)
Dolj No. 2	CRAIOVA UP I, ua. 80 (Criva)	<i>Q. frainetto</i> 90% <i>Q. cerris</i> 10% 80-90 y degraded 20-30% <i>Q.c.</i> increase	BRti Sol brun roscat tipic (slab luvic)	LVx Chromic Luvisols (weak luvic)
Dolj No. 3	CRAIOVA UP I, ua. 90 (Criva)	<i>Q. frainetto</i> 90% <i>Q. cerris</i> 10% 49-50y	BDti Sol brun argiloiluvial tipic	LVh Haplic Luvisols
Dolj No. 4	CRAIOVA UP II, ua. 62G (Bucovat)	<i>Q. frainetto</i> 70% 66y <i>Q. cerris</i> 30%	BDpz Sol brun argiloiluvial pseudogleizat	LVh-j Stagnic-Haplic Luvisols
Dolj No. 5	CRAIOVA UP IV, ua. 144A (Cosoveni)	<i>Q. frainetto</i> 90% 50y Others 10% degraded 30-40%	RPti Sol brun roscat luvic tipic	LVx Chromic Luvisols
Dolj No. 6	CRAIOVA UP IV, ua. 81B (Bratovoesti)	<i>Q. robur</i> 50% 120y <i>F. excelsior</i> 20% 80y <i>Carpinus sp.</i> 10% Others 20%	SAsc Sol aluvial salinizat	FLe-s Sali-Calcanic Fluvisols
Dolj No. 7	AMARADIA UP III, ua. 114B (Barota)	<i>Q. petraea</i> 100% 90y degraded 5-10% <i>Q.c.</i> increase	SPvspz Luvisol albic vertic pseudogleizat	LVa-v-j Stagnic-Vertic Albic Luvisols
Dolj No. 8	CRAIOVA UP III, ua. 46A (Seaca)	<i>Q. frainetto</i> 100% 62y degraded 25-30% <i>Q.c.</i> increase	BDvs Sol brun argiloiluvial vertic	LVv Vertic Luvisols (weak luvic)
Dolj No. 9	PERISOR UP I, ua. 114A (Verbicioara)	<i>Q. frainetto</i> 40% 90y <i>Q. cerris</i> 60%	RPvs Sol brun roscat luvic vertic	LVx-v Verti-Chromic Luvisols
Dolj No. 10	PERISOR UP I, ua. 119A (Verbicioara)	<i>Q. frainetto</i> 30% 90y <i>Q. cerris</i> 70% degraded 40%	RPvs Sol brun roscat luvic vertic	LVx-v Verti-Chromic Luvisols

## (Appendix B-2 continue)

Profile No.	Location Ocol Silvic, UP, ua.	Vegetation	Soil Classification	
			SRCS	FAO/UNESCO
Dolj No. 11	PERISOR UP III, ua. 57A (Timava)	<i>Q. frainetto</i> 40% 55y <i>Q. cerris</i> 50% <i>Q. pubescens</i> 10% degraded 10-15%	CCi Cemoziom cambic tipic	CHk Calcic Chernozems
Dolj No. 12	PERISOR UP II, ua. 27A (Izvoare, Rudari)	<i>Q. frainetto</i> 40% 55y <i>Q. cerris</i> 60% degraded 0-5%	BRti Sol brun roscat tipic slab luvic	LVx Chromic Luvisols
Dolj No. 13	POIANA MARE UP III, ua. 15A (Pisculet)	<i>Robinia pseudoacacia</i> 100% 22y	PSti Psamosol tipic (carbonatic)	ARc Calcaric Arenosols
Dolj No. 14	POIANA MARE UP III, ua. 11B (Pisculet)	<i>R. pseudoacacia</i> <i>Pinus nigra</i> 15y	PSti Psamosol tipic (carbonatic)	ARc Calcaric Arenosols
Dolj No. 15	APELE VII UP II, ua. 75C (Apele VII)	<i>R. pseudoacacia</i> degraded	PSti Psamosol tipic	ARh Haplic Arenosols
Dolj No. 16	APELE VII UP II, ua. 42C (Apele VII)	<i>R. pseudoacacia</i> 100% 46y	PSti Psamosol tipic	ARh Haplic Arenosols
Dolj No. 17	SEGARCEA UP III, ua. 72A (Radovan, Desnatui)	<i>Q. pedunculiflora</i> 30% 102y <i>F. excelsior</i> 60% Others( <i>Crataegus</i> ) 10% 82y	LCmo Lacoviste mollic	GLm Mollic Gleysols
Dolj No. 18	SEGARCEA UP III, ua. 84A (Radovan, Desnatui)	<i>Q. frainetto</i> 80% 49y <i>Q. cerris</i> 20% degraded 6%	BRti Sol brun roscat tipic	LVx Chromic Luvisols
Dolj No. 19	SADOVA UP III, ua. 11A (Zaval, Lunca Jiu)	<i>Q. robur</i> 40% 182y <i>F. excelsior</i> 60%	Sati Sol aluvial tipic	FLc Calcaric Fluvisols
Dolj No. 20	AMARADIA UP II, ua. 37D (Farcasi)	<i>Q. cerris</i> 70% <i>Q. frainetto</i> 20% <i>Q. petraea</i> 10%	BMti Sol brun eumezobazic tipic	CMe Eutric Cambisols

## (Appendix B-2 continue)

Profile No.	Location Ocol Silvic, UP, ua.	Vegetation	Soil Classification	
			SRCS	FAO/UNESCO
Olt No. 1	CARACAL UP III, ua. 52A (Resca)	<i>Q. robur</i> 60% 128y <i>F.e.</i> 30% 80-100y <i>Populus alba</i> 10% 71-82y	BMvs Sol brun eumezobazic vertic	CMv Vertic-(Eutric) Cambisols
Olt No. 2	BALS UP V, ua. 100 (Bistrita)	<i>Q. frainetto</i> 70% 54y <i>Q. cerris</i> 20% <i>Q. petrea</i> 10% degraded 15-25%	SPpz Luvisol albic Pseudogleizat	LVa-j Stagni-Albic Luvisols
Olt No. 3	BALS UP V, ua. 145 (Sanu)	<i>Q. frainetto</i> 60% <i>Q. cerris</i> 20% 59y <i>F. ornus</i> 10% <i>Piris comunitus</i> <i>Cratagus</i> degraded 35-40%	BMvs-pr Sol brun eumezobazic vertic pseudoreznicic	CMe-v Vertic-Eutric Cambisols
Olt No. 4	VULTURESII UP I, ua. 98D (Dumitresti)	<i>Q. frainetto</i> 80% 119y <i>F. ornus</i> , <i>Cratagus</i> , Others 20% 10y degraded 10%	SPgl-pz Luvisol albic glosic pseudogleizat	PDe-j Stagnic-Eutric Podzoluvisols
Olt No. 5	SLATINA UP V, ua. 37A (Seaca)	<i>Q. frainetto</i> 100% 140y degraded 10-15%	SPti Luvisol albic tipic	LVa Albic Luvisols
Olt No. 6	SLATINA UP IV OPORELU, ua. 123 (Ghiteasca)	<i>Q. frainetto</i> 100% 45y	BDvs Sol brun argiloiluvial vertic	LVv Vertic Luvisols
Olt No. 7	SLATINA UP IV OPORELU, ua. 151A (Corbu, Sinesti)	<i>Q. frainetto</i> 100% 70y <i>F. ornus</i> degraded 15%	SPro Luvisol albic rodic	LVa-x Chromic-Albic Luvisols
Olt No. 8	CARACAL UP I, ua. 35 (Vladila)	<i>Q. pedunculiflora</i> 60% <i>Q. pubescens</i> 40% 70y <i>Cratagus</i>	BRti Sol brun roscat tipic slab luvic	LVx Chromic Luvisols

SRCS: Sistemul Roman de Clasificare a Solurilor (1979)

FAO/UNESCO: Soil Map of the World, Revised Legend (1988)



Appendix B-3 Romanian Soil Classification Systems and Sub Type Symbols

S.R.C.S.(Romania Soil Classification System)				Sub type symbol			
ICAS Code (Book)	(Inventory) Code	Major Symbol	Romania Soil Name	Sub type Name		Sub type Name	
<b>Molisoluri</b>				ti	tipic	ar	argiloiluvial
1	11	SB	Sol balan	ls	litic	ro	rodic
2	12	CZ	Cernoziom	gz	gleizat	vs	vertic
3	13	CC	Cernoziom cambic	pz	pseudogleizat	pl	planic
4	14	CI	Cernoziom argiloiluvial	gc	gleic	um	umbric
5	15	CM	Sol cernoziomoid	pg	pseudogleic	vm	vermic
6	16	CN	Sol cenusiu	sc	salinizat	lv	luvic
7	17	RZ	Rendzina	ac	alcalizat	al	albic
8	18	PR	Pseudorendzina	ml	mlastinoasa	cr	cromic
<b>Argiluvisoluri</b>				tb	turbos (organic)	gl	glosic
9	21	BR	Sol brun-roscat	rz	rendzinic	cp	criptospodic
10	22	BD	Sol brun argiloiluvial	pr	pseudo-rendzinic	fe	feriiluvial
11	23	RP	Sol brun-roscatluvic (podzolit)	mo	molic	an	andic
12	24	BP	Sol brun-luvic (podzolit)	ca	cambic		
13	25	SP	Luvisol alvic (Sod podzolic argiloiluvial)				
14	26	PL	Planosol				
<b>Cambisoluri</b>							
15	31	BM	Sol brun eu-mezobazic				
16	32	TR	Sol rosu (terra rossa)				
17	33	BO	Sol brun acid				
<b>Spodosoluri</b>							
18	41	PB	Sol brun fertiluvial (podzolic)				
19	42	PD	Podzol				
<b>Molisoluri</b>							
20	51	NO	Sol negru acid				
21	52	AN	Andosol				
22	53	HS	Sol humicosilicatic				
<b>Soluri hidromorfe</b>							
23	61	LC	Lacoviste				
24	62	GC	Sol gleic				
25	63	NF	Sol negru clinohidromorf (Sol negru de finesta)				
26	64	PG	Sol pseudogleic				
<b>Soluri halomorfe</b>							
27	71	SC	Solonceac				
28	72	SN	Solonet				
<b>Vertisoluri</b>							
29	81	VS	Vertisol				
<b>Soluri neevoluate trunchiate sau desfundate</b>							
30	91	LS	Litosol				
31	92	RS	Regosol				
32	93	PS	Psamosol				
33	94	AA	Protosol aluvial (aluviune)				
34	95	SA	Sol aluvial				
35	96	ER	Erodisol				
36	97	CO	Coluvisol				
37	98	DD	Sol desfundat				
38	99	PA	Protosol antropic				
<b>Soluri organice (Histosoluri)</b>							
39	2	TB	Sol turbos (Organic)				

Appendix B-4 Reading of codes and marks of Romanian soil classification in FAO/UNESCO soil classification (1988)

Romania Soil Classification			FAO/UNESCO Soil Classification	Romania Soil Classification			FAO/UNESCO Soil Classification
Soil Code		Symbol	Soil Unit Symbol	Soil Code		Symbol	Soil Unit Symbol
Book	Invent	Major-sub	Level 1 - level 2	Book	Invent	Major-sub	Level 1 - level 2
0101	1101	SBti	KSk-c,KSh-c(Kastanozems)	0517	1517	CMar-gz	PIII-g
0102	1102	SBvm	KSk-c-vermi	0518	1518	CMar-pz	PIII-j
0103	1103	SBsc	KSk-c-s	0601	1601	CNti	GRh(Haplic Greyzems)
0104	1104	SBac	KSk-c-n	0602	1602	CNca	CHh(Haplic Chernozems)
0201	1201	CZti	CHk-c(Chernozems)	0603	1613	CNpr	
0202	1202	CZvm	CHk-c-vermi	0604	1604	CNgz	CHh-g
0203	1203	CZvs	CHk-c-v	0605	1605	CNpz	CHh-j
0204	1204	CZrz		0606	1606	CNca-pr	CHh
0205	1205	CZpr	PHc(Calcaric Phaeozems)	0607	1607	CNca-gz	CHh-g
0206	1206	CZls	CHk-c-lithi	0608	1608	CNpr-pz	CHh-j
0207	1207	CZgz	CHk-g	0701	1701	RZti	LPk(Rendzic Leptosols)
0208	1208	CZsc	CHk-c-s	0702	1702	RZca	LPk
0209	1209	CZac	CHk-c-n	0703	1703	RZls	LPk
0210	1210	CZvm-gz	CHk-c	0704	1704	RZca-ls	LPk
0211	1211	CZvs-gz	CHk-c-v	0801	1801	PRti	PHc(Calcaric Phaeozems)
0212	1212	CZvs-sc	CHk-c-v	0802	1802	PRvs	PHc-v
0213	1213	CZvs-ac	CHk-c-v	0803	1803	PRca	PHh
0214	1214	CZpr-sc	PHc	0804	1804	PRar	PHl
0215	1215	CZls-rz	CHk-c	0805	1805	PRpz	PHc-j
0216	1216	CZsc-ac	CHk-c	0806	1806	PRca-vs	PHh-v
0301	1301	CCti	CHk,PHh	0807	1807	PRca-pz	PHh-j
0302	1302	CCvm	CHk-vermi	0808	1808	PRar-vs	PHl-v
0303	1303	CCvs	CHk-v,PHh-v	0809	1809	PRar-pz	PHl-j
0304	1304	CCrz		0901	2101	BRti	LVx(Chromic Luvisols)
0305	1305	CCpr	PHh(Haplic Phaeozems)	0902	2102	BRmo	PHl-x
0306	1306	CCls	CHh-lithi	0903	2103	BRvs	LVx-v
0307	1307	CCgz	CHk-g	0904	2104	BRgz	LVx-g
0308	1308	CCsc	CHk-s	0905	2105	BRpz	LVx-j
0309	1309	CCac	CHk-n,PHh-n	0906	2106	BRmo-vs	PHl-x-v
0310	1310	CCvm-gz	CHk-vermi-g	0907	2107	BRmo-gz	PHl-x-g
0311	1311	CCvs-pr	CHk-v	0908	2108	BRvs-pz	LVx-v-j
0312	1312	CCvs-gz	CHk-v	1001	2201	BDti	LVh(Haplic Luvisols)
0313	1313	CCvs-sc	CHk-v	1002	2202	BDmo	PHl
0314	1314	CCvs-ac	CHk-v	1003	2203	BDvs	LVv(Vertic Luvisols)
0315	1315	CCse-ac	CHk-n	1004	2204	BDrz	
0401	1401	Clti	PHl(Luvic Phaeozems)	1005	2205	BDpr	
0402	1402	Clvs	PHl-v	1006	2206	BDro	LVx
0403	1403	Clrz		1007	2207	BDls	LVh-lithi
0404	1404	Cipr		1008	2208	BDgz	LVh-g
0405	1405	Clgz	PHl-g	1009	2209	BDpz	LVh-j
0406	1406	Clpz	PHl-j	1010	2210	BDac	LVh-n
0407	1407	Clse		1011	2211	BDmo-vs	PHl-v
0408	1408	Clac	PHl-n	1012	2212	BDmo-rz	PHl
0409	1409	Clvs-pr	PHl-v	1013	2213	BDmo-pr	PHl
0410	1410	Clvs-gz	PHl-v	1014	2214	BDmo-gz	PHl-g
0411	1411	Clvs-pz	PHl-v	1015	2215	BDmo-pz	PHl-j
0412	1412	Clvs-sc	PHl-v	1016	2216	BDmo-ac	PHl-n
0413	1413	Clvs-ac	PHl-v	1017	2217	BDvs-pr	LVv
0501	1501	CMti	PHk(Calcaric Phaeozems)	1018	2218	BDvs-gz	LVv-g
0502	1502	CMvs	PHk-v	1019	2219	BDvs-pz	LVv-j
0503	1503	CMca	PHh(Haplic Phaeozems)	1020	2220	BDro-rz	LVx
0504	1504	CMar	PHl(Luvic Phaeozems)	1021	2221	BDpr-pz	LV
0505	1505	CMrz		1022	2222	BDgz-pz	LVj-g
0506	1506	CMpr		1101	2301	RPti	LVx
0507	1507	CMgz	PHc-g	1102	2302	RPvs	LVx-v
0508	1508	CMpz	PHj(Stagnic Phaeozems)	1103	2303	RPpl	LVx
0509	1509	CMvs-pr	PHk-v	1104	2304	RPgz	LVx-g
0510	1510	CMvs-gz	PHk-v	1105	2305	RPpz	LVx-j
0511	1511	CMca-vs	PHh	1106	2306	RPvs-pl	LVx-v
0512	1512	CMca-rz	PHh-v	1107	2307	RPvs-pz	LVx-v
0513	1513	CMca-pr	PHh	1108	2308	RPpl-pz	LVx-j
0514	1514	CMca-gz	PHh-g	1201	2401	BPti	LVh
0515	1515	CMar-vs	PHl-v	1202	2402	BPvs	LVv
0516	1516	CMar-pr	PHl	1203	2403	BPpl	LVh

Romania Soil Classification			FAO/UNESCO Soil Classification	Romania Soil Classification			FAO/UNESCO Soil Classification
Soil Code		Symbol	Soil Unit Symbol	Soil Code		Symbol	Soil Unit Symbol
Book	Invent	Major-sub	Level 1 - level 2	Book	Invent	Major-sub	Level 1 - level 2
1204	2404	BPro	LVx	1518	3118	BMmo-sc	PHh-s
1205	2405	BPls	LVh-lithi	1519	3119	BMmo-ac	PHh-n
1206	2406	BPgz	LVh-g	1520	3120	BMvs-pr	CMv
1207	2407	BPpz	LVh-j	1521	3121	BMpr-pz	CMe-j
1208	2408	BPvs-pl	LVv	1522	3122	BMan-ls	CMe-andi-lithi
1209	2409	BPvs-pz	LVv-j	1523	3123	BMsc-ac	CMe-s-n
1210	2410	BPpl-pz	LVh-j	1524	3124	BMgz-pz	CMe-j-g
1211	2411	BPro-ls	LVx-lithi	1601	3201	TRti	CMx(Chromic Cambisols)
1212	2412	BPro-pz	LVx-j	1602	3202	TRls	CMx-lithi
1213	2413	BPgz-pz	LVj-g	1701	3301	BOti	CMd(Dystric Cambisols)
1301	2501	SPti	LVa(Albic Luvisols)	1702	3302	BOum	CMu(Humic Cambisols)
1302	2502	SPvs	LVa-v	1703	3303	BOan	CMd-andi
1303	2503	SPpl	LVa	1704	3304	BOcp	CMd-spodo
1304	2504	SPgl	PDe(Eutric Podzoluvisols),PDD	1705	3305	BOls	CMd-lithi
1305	2505	SPro	LVa-x	1706	3306	BOgz	CMd-g
1306	2506	SPls	LVa-lithi	1707	3307	BOum-an	CMu-andi
1307	2507	SPgz	LVa-g	1708	3308	BOum-ls	CMu-lithi
1308	2508	SPpz	LVa-j	1709	3309	BOan-ls	CMd-andi-lithi
1309	2509	SPpg	LVa-j	1710	3310	BOcr-um	CMu-spodo
1310	2510	SPac	LVa-n	1711	3311	BOcr-ls	CMd-spodo-lithi
1311	2511	SPvs-pl	LVa-v	1801	4101	PBti	PZb(Cambic Podzols)
1312	2512	SPvs-pz	LVa-v	1802	4102	PBls	PZb-lithi
1313	2513	SPvs-pg	LVa-v	1803	4103	PBtb	PZb-histi
1314	2514	SPvs-ac	LVa-v	1901	4201	PDti	PZh(Haplic Podzols)
1315	2515	SPpl-pz	LVa-j	1902	4202	PDfe	PZf(Ferric Podzols)
1316	2516	SPpl-ac	LVa-n	1903	4203	PDls	PZh-lithi
1317	2517	SPpl-pg	LVa-j	1904	4204	PDtb	PZh-histi
1318	2518	SPgl-pz	PDe-j,PDD-j	1905	4205	PDfe-ls	PZf-lithi
1319	2519	SPgl-pg	PDj(Stagnic Podzoluvisols)	2001	5101	NOti	CMu
1320	2520	SPgl-ac	PDe-n	2002	5102	NOan	CMu-andi
1321	2521	SPro-ls	LVa-x	2003	5103	NOls	CMu-lithi
1322	2522	SPro-pz	LVa-x	2004	5104	NOgz	CMu-g
1323	2523	SPgz-pz	LVa-g-j	2005	5105	NOan-ls	CMu-andi-lithi
1324	2524	SPgz-pg	LVa-g-j	2101	5201	ANti	ANu(Umbic Andosols)
1325	2525	SPpz-ac	LVa-j-n	2102	5202	ANca	ANh(Haplic Andosols),ANu
1401	2601	PLti	PLe(Eutric Planosols)	2103	5203	ANls	ANu-lithi
1402	2602	PLmo	PLm(Mollic Planosols)	2104	5204	ANca-ls	ANh-lithi
1403	2603	PLvs	PLe-v	2201	5301	HSti	LPu(Umbic Leptosols),LPd
1404	2604	PLal	PLd(Dystric Planosols)	2202	5302	HScp	CMu-spodo
1405	2605	PLgz	PLe-g	2203	5303	HSls	LPu-lithi
1406	2606	PLpg	PLc	2204	5304	HScp-ls	CMu-spodo-lithi
1407	2607	PLmo-vs	PLm-v	2301	6101	LCti	PHg,CHh-g
1408	2608	PLmo-gz	PLm-g	2302	6102	LCca	PHg(Gleyic Phaeozems)
1409	2609	PLvs-pg	PLe-v	2303	6103	LCml	GLm(Mollic Gleysols)
1410	2610	PLal-vs	PLd-v	2304	6104	LCsc	CHh-g-s
1411	2611	PLal-gz	PLd-g	2305	6105	LCac	CHh-g-n
1412	2612	PLal-pg	PLe,PLd	2306	6106	LCca-sc	PHg-s
1501	3101	BMti	CMe(Eutric Cambisols)	2307	6107	LCca-ac	PHg-n
1502	3102	BMmo	PHh(Haplic Phaeozems)	2308	6108	LCml-sc	GLm-s
1503	3103	BMvs	CMv(Vertic Cambisols)	2309	6109	LCsc-ac	CHh-g-s-n
1504	3104	BMrz		2401	6201	Gcti	CMg(Gleyic Cambisols)
1505	3105	BMpr	CMe	2402	6202	Gcmo	PHg
1506	3106	BMan	CMe-andi	2403	6203	GCum	CMu-g
1507	3107	BMls	CMe-lithi	2404	6204	GCca	CMg
1508	3108	BMgz	CMg,CMe-g	2405	6205	GCml	GLE(Eutric Gleysols)
1509	3109	BMpz	CMe-j	2406	6206	GCtb	GLm(Mollic Gleysols)
1510	3110	BMsc	CMe-s	2407	6207	GCsc	CMg-s
1511	3111	BMac	CMe-n	2408	6208	GCac	CMg-n
1512	3112	BMmo-vs	PHh-v	2409	6209	GCmo-ca	PHg
1513	3113	BMmo-rz	CMe-rendzi	2410	6210	GCmo-ml	GLm
1514	3114	BMmo-pr	PHh	2411	6211	GCmo-sc	GLm-s
1515	3115	BMmo-an	PHh-andi	2412	6212	GCmo-ac	GLm-n
1516	3116	BMmogz	PHh-g	2413	6213	GCml-sc	GLE-s
1517	3117	BMmo-pz	PHh-j	2414	6214	GCsc-ac	CMg-s-n

Romania Soil Classification			FAO/UNESCO Soil Classification	Romania Soil Classification			FAO/UNESCO Soil Classification
Soil Code		Symbol	Soil Unit Symbol	Soil Code		Symbol	Soil Unit Symbol
Book	Invent	Major-sub	Level 1 - level 2	Book	Invent	Major-sub	Level 1 - level 2
2501	6301	NFti	PHg-j	3101	9201	RSti	RGe(Eutric Regosols),RGe
2502	6302	NFar	PHl-j	3102	9202	RSmo	RGe-m,RGe-m
2503	6303	NFvs	PHj-v	3103	9203	RSum	RGU(Umbic Regosols)
2504	6304	NFar-vs	PHl-j-v	3104	9204	RSrz	LPk(Rendzic Leptosols),RGe-k
2601	6401	PGti	CMe-j	3105	9205	RSpr	RGe(Calcaric Regosols)
2602	6402	PGmo	PHj(Stagnic Phaeozems)	3106	9206	RSls	LPe(Eutric Leptosols)
2603	6403	PGvs	CMe-v-j	3107	9207	RSsc	RGe
2604	6404	PGlv	LVj(Stagnic Luvisols)	3108	9208	RSmo-rz	LPk
2605	6405	PGal	LVj-a	3109	9209	RSmo-pr	RGe-m
2606	6406	PGpl	LVa-j	3110	9210	RSmo-ls	LPm(Mollic Leptosols)
2607	6407	PGgz	CMg-j	3111	9211	RSmo-sc	RGe
2608	6408	PGml	CMe-j-hyper	3112	9212	RSum-ls	RGU
2609	6409	PGtb	CMe-j-histi	3113	9213	RSrz-ls	LPq-k
2610	6410	PGvs-lv	LVj-v	3201	9301	PSti	ARh(Haplic Arenosols),ARc
2611	6411	PGvs-al	LVa-j-v	3202	9302	PSmo	ARh-m,ARc-m
2612	6412	PGlv-pl	LVj	3203	9303	PSgz	ARh-g,ARc-g
2613	6413	PGlv-gz	LVg-j	3204	9304	PSgc	ARG(Gleyic Arenosols)
2614	6414	PGal-pl	LVa(Albic Luvisols)	3205	9305	PSsc	ARG-s
2615	6415	PGal-gz	LVa-g-j	3206	9306	PSmo-gz	ARh-m-g
2616	6416	PGpl-gz	LVa(Albic Luvisols)	3207	9307	PSmo-sc	ARh-m-s
2617	6417	PGpl-ml	LVa	3208	9308	PSgc-sc	ARG-s
2618	6418	PGpl-tb	LVa	3301	9401	AAti	FLe(Eutric Fluvisols),FLc
2701	7101	SCti	SCh(Haplic Solonchaks)	3302	9402	AAIs	FLe-rudi,FLc-rudi
2702	7102	SCmo	SCm(Mollic Solonchaks)	3303	9403	AAgz	FLe-g,FLc-g
2703	7103	SCvs	SCh-v	3304	9404	AAsc	FLc-s
2704	7104	SCgc	SCg(Gleyic Solonchaks)	3401	9501	SAti	FLe,FLc,FLd
2705	7105	SCac	SCn(Sodic Solonchaks)	3402	9502	SAmo	FLm(Mollic Fluvisols)
2706	7106	SCmo-vs	SCm-v	3403	9503	SAum	FLu
2707	7107	SCmo-gc	SCm-g	3404	9504	SAvs	FLe-v,FLd-v
2708	7108	SCvs-gc	SCh-v-g	3405	9505	SAls	FLe-rudi,FLc-rudi,FLd-rudi
2709	7109	SCgc-ac	SCg-n	3406	9506	SAGz	FLe-g
2801	7201	SNti	SNg(Gleyic Solonetz),SNh	3407	9507	SAsc	FLe-s,FLc-s
2802	7202	SNlv	SNh(Haplic Solonetz)	3408	9508	SAac	FLe-n,FLc-n
2803	7203	SNal	SNj(Stagnic Solonetz),SNh	3409	9509	SAmo-vs	FLm-v
2804	7204	SNgl	SNh,SNj	3410	9510	SAmo-ls	FLm
2805	7205	SNca		3411	9511	SAmo-gz	FLm-g
2806	7206	SNmo	SNh	3412	9512	SAmo-sc	FLm-s
2807	7207	SNsc	SNh-sali	3413	9513	SAmo-ac	FLm-n
2808	7208	SNgc	SNg(Gleyic Solonetz)	3414	9514	SAum-ls	FLu(Umbic Fluvisols)
2809	7209	SNlv-sc	SNg	3415	9515	SAum-gz	FLu
2810	7210	SNlv-gc	SNg	3416	9516	SAvs-gz	FLe-v-g
2811	7211	SNal-sc	SNh-sali	3417	9517	SAvs-sc	FLe-v-s
2812	7212	SNal-gc	SNh,SNj	3418	9518	SAvs-ac	FLe-v-n
2813	7213	SNgl-sc	SNj(Stagnic Solonetz)	3419	9519	SAsc-ac	FLe-s-n
2814	7214	SNgl-gc	SNj	3501	9601	BRti	RGe,RGe
2815	7215	SNca-sc	SNh	3502	9602	ERrz	RGe-rendzi
2816	7216	SNca-gc	SNh	3503	9603	ERpr	RGe(Calcaric Regosols)
2817	7217	SNmo-sc	SNh	3504	9604	ERls	RGe
2818	7218	SNmo-gc	SNh	3505	9605	ERvs	RGe-v
2819	7219	SNsc-gc	SNh	3506	9606	ERgz	RGe-g,RGe-g
2901	8101	VSti	VRk(Calcaric Vertisols),VRe	3507	9607	ERpz	RGe-j
2902	8102	VScr	VRe(Eutric Vertisols)	3508	9608	ERsc	RGe-s,RGe-s
2903	8103	VSgz	VRe-g	3509	9609	ERac	RGe-n,RGe-n
2904	8104	VSpz	VRe-j	3510	9610	ERca	RGe
2905	8105	VSc	VRe-s	3511	9611	ERar	RGe-l
2906	8106	VSac	VRe-n	3512	9612	ERfe	RG
2907	8107	VScr-gz	VRe-g	3513	9613	ERro	
2908	8108	VScr-pz	VRe-j	3514	9614	ERan	RGe-andi
2909	8109	VScr-sc	VRe-s	3515	9615	ERrz-ls	RGe
2910	8110	VScr-ac	VRe-n	3516	9616	ERpr-pz	RGe-j
3001	9101	LSti	LPe,LPq(Lithic Leptosols),LPd	3517	9617	ERpz-vs	RGe-j
3002	9102	LSrz	LPq(Lithic Leptosols)-k	3518	9618	ERca-rz	RGe
3003	9103	LStb	LPu-histi	3519	9619	ERca-pr	RGe
3004	9104	LSrz-tb	LPq-k-histi	3520	9620	ERca-gz	RGe

## (Appendix B-4 continued)

Romania Soil Classification		FAO/UNESCO Soil Classification	
Soil Code	Symbol	Soil Unit Symbol	
Book	Invent	Major-sub	Level 1 - level 2
3521	9621	ERca-pz	RGe
3522	9622	ERca-sc	RGe
3523	9623	ERca-ac	RGe
3524	9624	ERar-pr	RGe
3525	9625	ERar-gz	RGe-l-g
3526	9626	ERar-pz	RGe-l-j
3527	9627	ERar-ac	RGe-l-n
3601	9701	COii	FLe,FLc
3602	9702	COmo	FLm
3603	9703	COgz	FLe-g,FLc-d
3604	9704	COpz	FLe-j
3605	9705	COsc	FLc-s
3606	9706	COmo-gz	FLm-g
3607	9707	COmo-sc	FLm-s
3701	9801	DDii	ATa(Aric Anthrosols)
3702	9802	DDmo	ATa
3703	9803	DDca	ATa
3704	9804	DDar	ATa
3801	9901	PATi	AT(Anthrosols)
3901	0201	TBTi	HS(Histosols)
3902	0202	TBsc	HS

## Romania Soil - FAO/UNESCO Soil Classification Revised Legend (1988)

AN	Andosols	haplic	umbric					
		ANh	ANu					
AT	Anthrosols	aric						
		ATa						
AR	Arenosols	calcaric	cambic	dystrie	gleyic	haplic		
		ARc	ARb	ARD	ARg	ARh		
CM	Cambisols	dystrie	eutric	gleyic	humic	vertic		
		CMd	CMe	CMg	CMu	CMv		
CH	Chernozems	calcic	gleyic	haplic	luvic			
		CHk	CHg	CHh	CHI			
FL	Fluvisols	calcaric	dystrie	eutric	mollic	salic	umbric	
		FLc	FLd	FLe	FLm	FLs	FLu	
GL	Gleysols	calcic	dystrie	eutric	mollic	umbric		
		GLk	GLd	GLE	GLm	GLu		
GR	Greyzems	haplic						
		GRh						
HS	Histosols	fibric						
		HSf						
KS	Kastanozems	calcic	haplic					
		KSk	KSh					
LP	Leptosols	dystrie	eutric	lithic	mollic	rendzic		
		LPd	LPe	LPq	LPm	LPk		
LV	Luvissols	albic	calcic	chromic	gleyic	haplic	stagnic	vertic
		LVA	LVk	LVx	LVg	LVh	LVj	LVv
PH	Phaeozems	calcaric	gleyic	haplic	luvic	stagnic		
		PHc	PHg	PHh	PHi	PHj		
PL	Planosols	dystrie	eutric	mollic				
		PLd	PLe	PLm				
PD	Podzoluvisols	dystrie	eutric	stagnic				
		PDd	PDe	PDj				
PZ	Podzols	cambic	ferric	haplic				
		PZb	PZf	PZh				
RG	Regosols	calcaric	dystrie	eutric				
		RGc	RGd	RGe				
SC	Solonchaks	calcic	gleyic	haplic	mollic	sodic		
		SCk	SCg	SCh	SCm	SCn		
SN	Solonetz	calcic	gleyic	haplic	mollic	stagnic		
		SNk	SNg	SNh	SNm	SNj		
VR	Vertisols	calcic	dystrie	eutric				
		VRk	VRd	VRe				

Appendix B-5 Measurement data of soil hardness (soil penetration resistance)

(1) Non soil-improved area in Olt and Dolj Counties

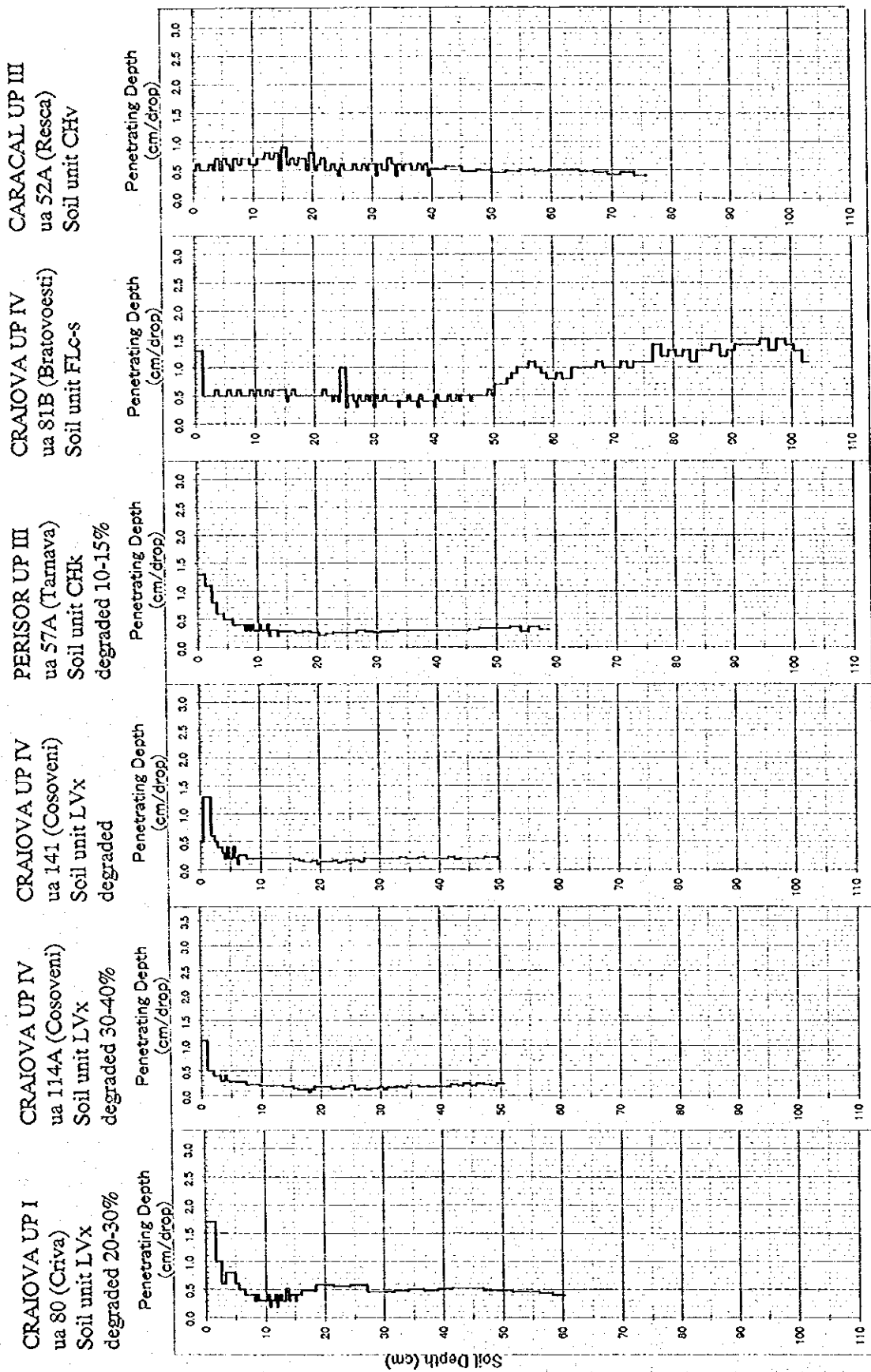

Appendix B-5 Measurement data of soil hardness (soil penetration resistance)

(2) Soil-improved area at Ghimpati forests

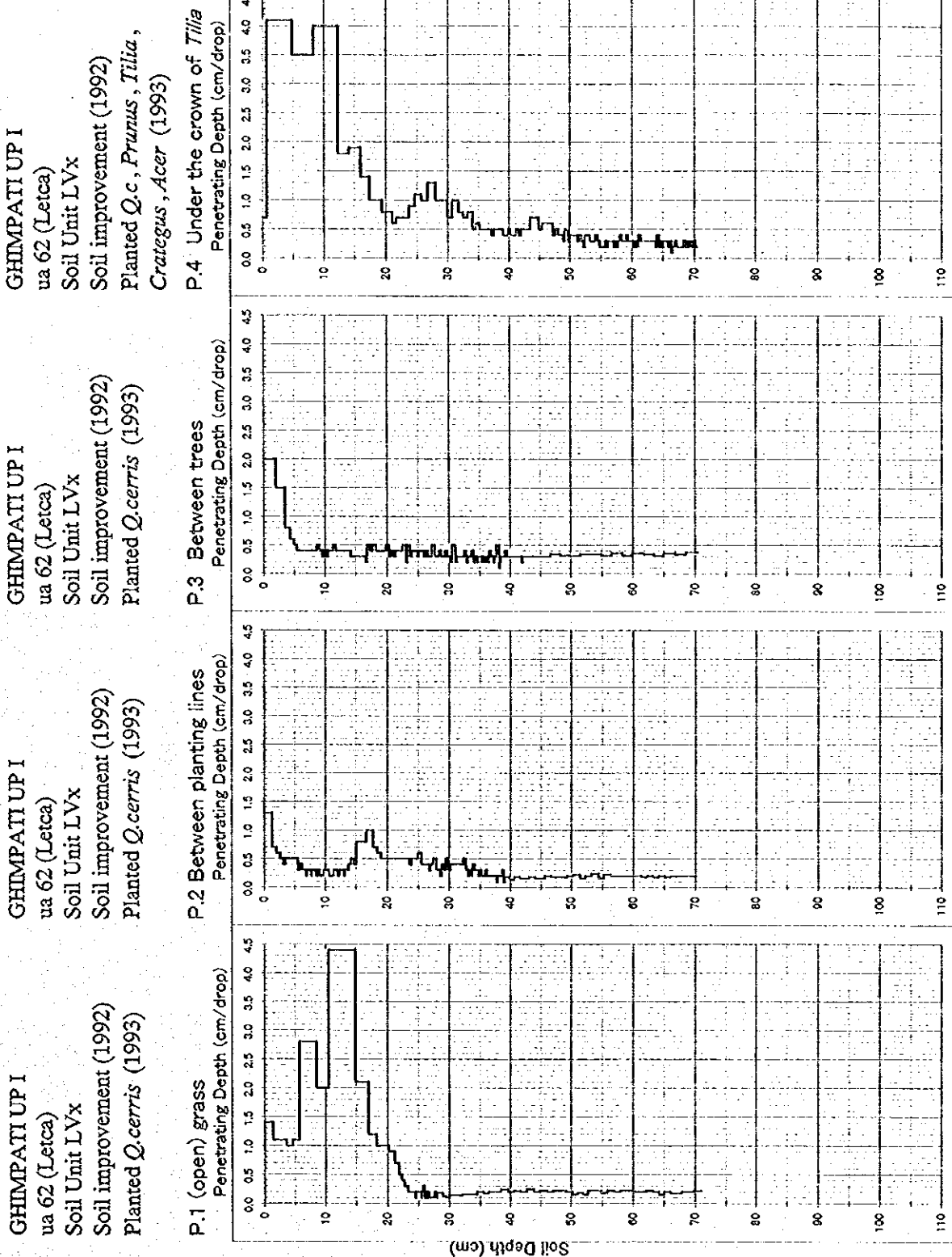

Appendix B-5 Measurement data of soil hardness (soil penetration resistance)

(3) Non soil-improved area at Ghimpati forests

GHIMPATI UP I  
 ua 63 (Letca)  
 Soil Unit LVx  
*Q.cerris* (50%)  
*Q.frainetto* (50%)  
 54 y  
 Hard, Dry

GHIMPATI UP I  
 ua 63 (Letca)  
 Soil Unit LVx  
*Q.cerris* (50%)  
*Q.frainetto* (50%)  
 54 y  
 Hard, Dry

GHIMPATI UP I  
 ua 82 (Letca)  
 Soil Unit LVx  
*Q.cerris* (90%)  
*Q.frainetto* (10%)  
 60 y  
 Hard, Dry

GHIMPATI UP I  
 ua 82 (Letca)  
 Soil Unit LVx  
*Q.cerris* (90%)  
*Q.frainetto* (10%)  
 60 y  
 Hard, Dry

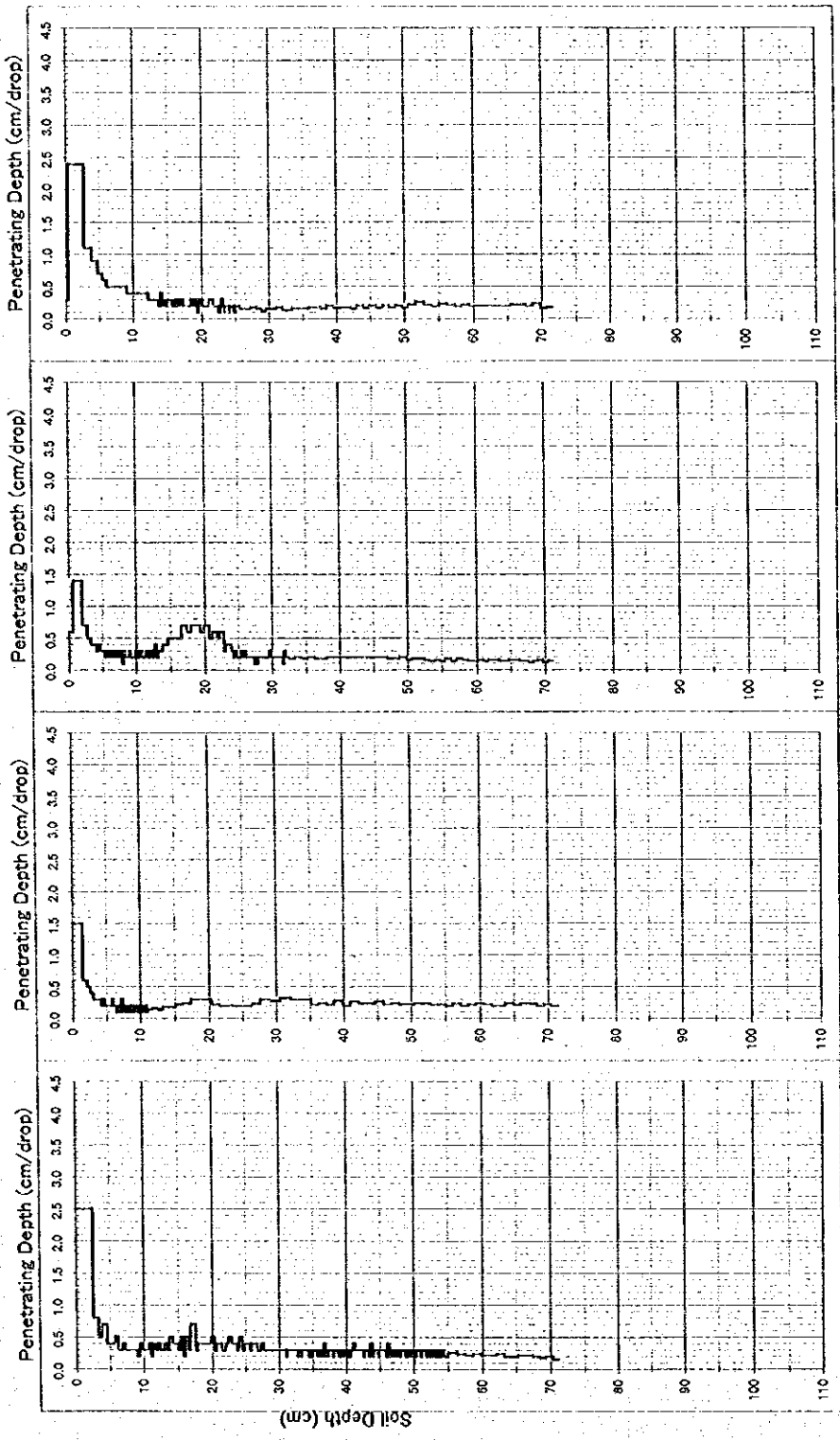



Appendix B-5 土壤硬度(土壤貫入抵抗)測定データ  
 (4) 土壤硬度の測定

土壤硬度

土壤硬度とは、加えられた外力に対する土壤の抵抗力をいい、ある大きさの物体を土壤中に圧入する際に要する単位断面積当たりの抵抗値(圧入抵抗:  $\text{kgf cm}^{-2}$ )であらわす。その物理的内容は、基本的には土壤粒子間の凝集力と摩擦力を主体とすると考えられる。土壤硬度には、粒径組成、孔隙量、乾燥密度、有機物、水分状態などが複合的に反映している。

山中式土壤硬度計

日本において、土壤硬度の測定には、山中・松尾(1962)が考案した山中式土壤硬度計が一般的に用いられている。その基本構造は図-1のとおりである。硬度計の円錐部を土壤に圧入すると、土壤の硬度に応じて円錐部が抵抗を受け、円錐底面を支えているコイルばねが縮み、その分だけ円錐部は内部に後退する。山中式硬度計では、通常40mmの縮みに対し8.0kgfの圧縮率を有するコイルばねが装着されている。胴体部側面には目盛りが刻印されており、遊動指標の停止点で硬度を読みとる。目盛りには指標硬度(mm)あるいは圧入抵抗値( $\text{kgf cm}^{-2}$ )が表示されている。

貫入式土壤硬度計(長谷川式土壤貫入計)

貫入抵抗は、土壤中に円錐などの貫入体を貫入する際に要する力である。貫入体が円錐の場合、貫入に対して土壤が示す抵抗の内容は、基本的には土壤粒子間の凝集力と粒子間の摩擦力であり、山中式硬度計の場合と同じであるが、円錐の頂角や底面積などの形状や貫入速度により、土壤の弾性、塑性、粘性、摩擦、毛管力の関与が異なる。

山中式硬度計が、土壤の硬さに応じて円錐の一部を土壤中に貫入する方法であるのに対して、貫入式土壤硬度計は、貫入体である円錐を土壤中に連続して貫入する方法である。本調査で使用した長谷川式土壤貫入計の基本構造を図-2に示す。貫入式硬度計は、試坑を掘らずに1名でも操作でき、作物根の伸長に対する土壤硬度の可否判定や耕盤層の確認にも利用できる。

土壤硬度測定値の見方について

土壤硬度基準	断面調査で使用 山中式硬度計		試坑なしで使用 土壤貫入計
	指標硬度 (mm)	圧入抵抗値	貫入深 (cm/drop)
Soft	15 mm以下		1.4 cm以上
Middle	15 mm	$\approx 3.0 \text{ kg/cm}^2$ $\approx 300 \text{ kPa}$	1.4 cm
	23 mm	$\approx 10.0 \text{ kg/cm}^2$ $\approx 1,000 \text{ kPa}$	0.4 cm
Hard	27 mm	$\approx 20.0 \text{ kg/cm}^2$ $\approx 2,000 \text{ kPa}$	0.2 cm
	30 mm	$\approx 38.0 \text{ kg/cm}^2$ $\approx 3,800 \text{ kPa}$	0.1 cm
Very Hard	32 mm	$\approx 63.0 \text{ kg/cm}^2$ $\approx 6,300 \text{ kPa}$	

但し、ルーマニア南西部平原の土壤(乾燥時)の場合

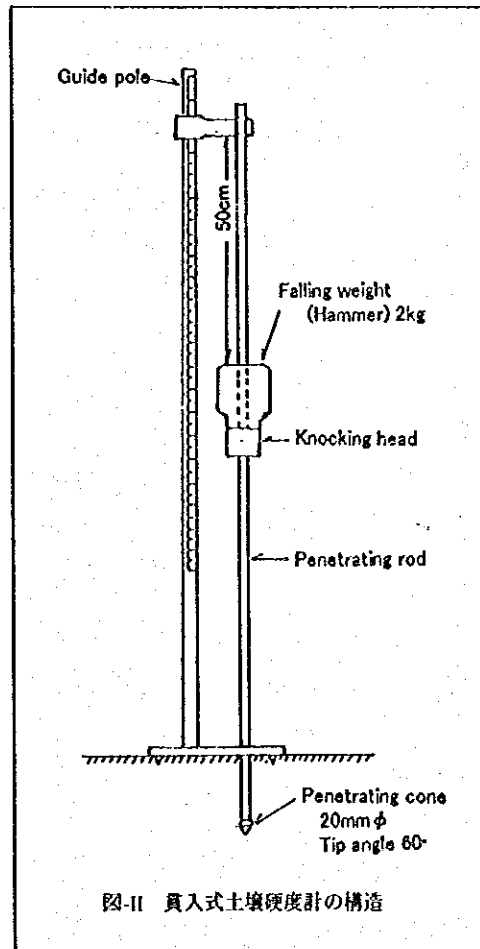
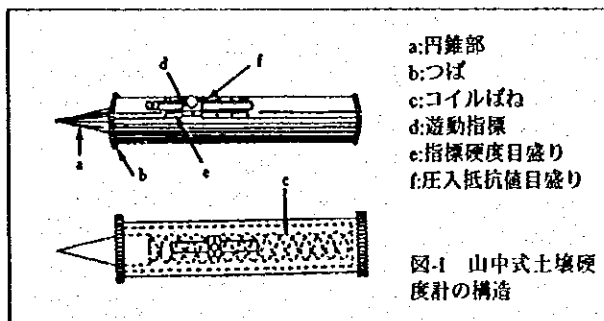



## Appendix C 社会経済

---

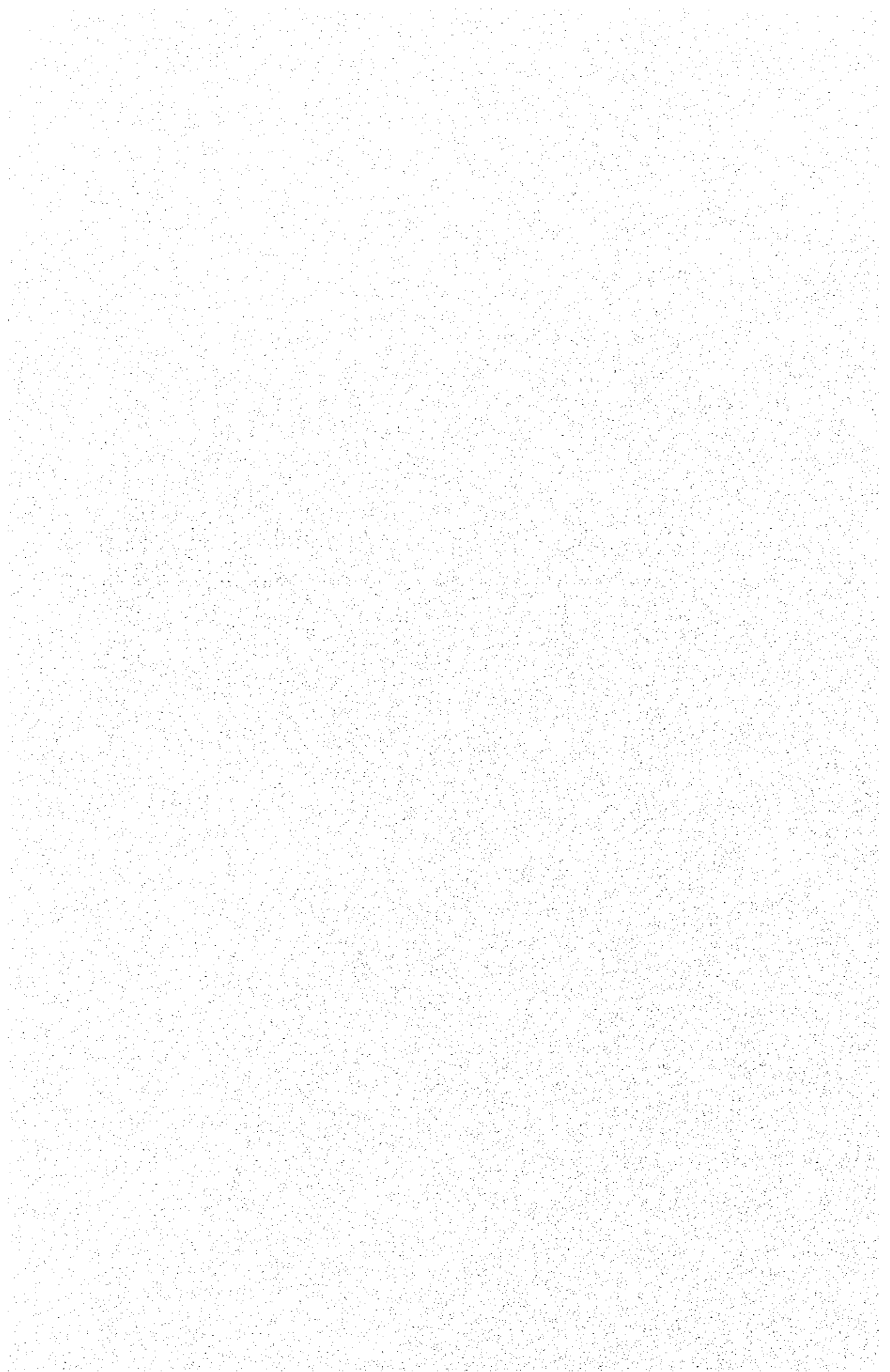

## Appendix C: 社会经济

### Appendix C-1 Statistics of Romanian Economy

#### 1. Romania Country

Table1-1 Population at 1st July

	1970	1980	1985	1990	1995	1996
Total	20,252,541	22,201,387	22,724,836	23,206,720	22,680,951	22,607,620
Urban (%)	36.9	45.8	50.0	54.3	54.9	54.9
Rural (%)	63.1	54.2	50.0	45.7	45.1	45.1

Source: Romanian Statistical Yearbook, 1997

Table1-2 Total land area by use (end of year)

thou hectares	1991	1992	1993	1994	1995	1996
Total area of the land fund	23,839.1	23,839.1	23,839.1	23,839.1	23,839.1	23,839.1
Agricultural area	14,798.3	14,790.1	14,793.1	14,797.5	14,797.2	14,788.7
Arable	9,423.5	9,356.9	9,341.5	9,338.0	9,337.1	9,338.9
Pastures	3,309.8	3,349.2	3,362.6	3,378.4	3,392.4	3,391.7
Hayfields	1,467.9	1,480.6	1,489.3	1,493.7	1,497.7	1,498.5
Vineyards and nurseries	285.8	298.6	303.9	298.4	292.4	289.0
Orchards and nurseries	311.3	304.8	295.8	289.0	277.6	270.6
Forests and other forest vegetation lands	6,680.1	6,681.8	6,681.1	6,680.2	6,680.1	6,690.3
Forests	6,253.4	6,253.5	6,249.2	6,245.8	6,244.7	6,240.2
Construction	624.2	630.5	627.9	629.6	627.2	626.3
Roads and railways	390.9	393.4	394.0	392.5	396.2	397.0
Waters and ponds	893.4	892.8	892.6	888.3	889.8	886.9
Other areas	452.2	450.5	450.4	451.0	448.6	449.9
Total area provided with irrigation facilities	3,197.2	3,202.3	3,202.8	3,205.2	3,211.1	3,190.6
Agricultural area	3,095.3	3,099.9	3,101.7	3,104.3	3,110.1	3,095.6
Arable area	2,920.3	2,924.4	2,925.5	2,929.1	2,934.6	2,921.4

Source: Romanian Statistical Yearbook, 1997

Table1-3 Agricultural production

thou tonnes	1991	1992	1993	1994	1995	1996
Cereal grains	19,306.6	12,288.5	15,493.1	18,183.8	19,882.8	14,199.7
Wheat and rye	5,558.9	3,227.6	5,354.5	6,186.5	7,709.3	3,164.1
Barley and two-row barley	2,950.7	1,678.0	1,552.8	2,133.6	1,816.3	1,107.5
Oats	258.2	507.7	553.6	496.8	404.4	290.5
Maize	10,497.3	6,828.3	7,987.5	9,343.2	9,923.1	9,607.9
Sorghum	6.0	4.5	5.5	7.1	4.4	4.3
Rice	31.4	38.9	36.4	15.2	24.1	23.1
Leguminous crops for grains	79.5	74.7	85.2	76.1	97.0	77.0
Peas	32.3	33.2	36.4	38.1	54.3	33.7
Beans	46.0	41.2	48.4	37.4	41.8	42.1
Fibre crops	73.7	64.2	14.6	9.3	13.1	17.1
Flax fibre	15.4	25.6	7.2	4.8	7.2	4.1
Hemp fibre	58.3	38.6	7.4	4.5	5.9	13.0
Oilseed crops	823.4	920.3	820.8	874.1	1,055.4	1,218.7
Sunflower	612.0	774.0	695.8	763.7	932.9	1,095.6
Rape	8.8	1.4	1.4	0.3	0.4	1.9
Soybeans	178.6	126.2	95.4	100.1	107.9	113.1
Flax for oil	22.8	17.9	28.0	6.5	4.7	4.5
Castor plant	0.6	0.6	0.1	*	*	0.1
Crops for other industrial purposes						
Sugar beet	4,702.7	2,896.7	1,776.3	2,763.8	2,654.6	2,848.2
Tobacco	13.9	7.6	10.5	13.0	13.4	12.1
Chicory						
Medicinal and aromatic plants	20.9	21.5	12.1	6.3	12.1	6.6
Potatoes	1,872.8	2,601.6	3,708.9	2,946.7	3,019.9	3,591.4
Autumn potatoes	1,634.1	2,332.2	3,354.1	2,620.1	2,681.3	3,246.3

Source: Romanian Statistical Yearbook, 1997

Table1-4 Structure of industrial production by activities

%	1991	1992	1993	1994	1995	1996
<b>Total</b>	<b>100</b>	<b>100</b>	<b>100</b>	<b>100</b>	<b>100</b>	<b>100</b>
<b>Mining and quarrying</b>	<b>8.9</b>	<b>7.5</b>	<b>6.8</b>	<b>7.1</b>	<b>6.9</b>	<b>6.8</b>
Coal mining and preparation	1.1	2.2	2.1	2.4	2.2	2.2
Petroleum and natural gas extraction	6.7	4.4	4.0	3.7	3.6	3.6
Metalliferous ores quarrying and preparation	0.4	0.4	0.3	0.5	0.5	0.4
Other extractive activities	0.5	0.4	0.4	0.4	0.5	0.5
<b>Manufacturing</b>	<b>83.5</b>	<b>81.6</b>	<b>84.6</b>	<b>79.6</b>	<b>80.5</b>	<b>81.9</b>
Food and beverages	14.8	14.7	19.4	15.9	16.3	17.1
Tobacco industry	0.5	0.4	0.6	0.5	0.5	0.7
Textiles and textile products	6.7	4.9	4.3	3.5	3.7	3.3
Textile, fur and leather wearing apparel	2.7	2.1	2.6	2.2	2.1	2.4
Leather goods and footwear	1.9	1.7	1.6	1.2	1.5	1.4
Wood processing (excluding furniture)	1.8	2.0	1.8	1.8	1.9	1.9
Pulp, paper and cardboard	1.5	1.4	1.0	0.9	1.2	1.2
Publishing houses, polygraphy and records reproduction on supports	0.3	0.3	1.5	1.1	1.1	1.3
Crude oil processing, coal coking and nuclear fuel treatment	6.5	6.7	8.6	7.7	7.7	6.4
Chemistry and synthetic and man made fibres	7.8	8.9	7.4	7.5	8.7	7.8
Rubber and plastics processing	2.6	2.2	2.3	1.6	2.1	2.1
Other nonmetallic mineral products	3.6	3.9	2.9	3.7	3.8	3.9
Metallurgy	9.6	10.6	8.8	9.5	10.4	10.4
Metallic construction and metal products	3.3	3.0	2.5	4.4	2.8	3.0
Machinery and equipment	7.8	7.5	6.2	5.4	5.8	5.6
Computers and office means	0.1	0.1	0.3	0.1	0.2	0.4
Electric machinery and appliances	2.4	2.2	1.7	1.8	2.0	2.3
Radio, TV and communications equipment and apparatus	0.7	0.4	4.1	3.2	0.9	1.2
Medical, precision, optical, watchmaking instruments and apparatus	0.9	0.6	0.3	0.3	0.4	0.5
Means of road transport	3.5	3.1	2.7	2.9	3.0	4.2
Other means of transport	2.1	2.6	1.5	1.3	1.5	1.7
Furniture and other nonclassified activities	2.3	2.2	2.2	2.8	2.6	2.7
Waste recovering	0.1	0.1	0.3	0.3	0.3	0.4
<b>Electric and thermal energy, gas and water</b>	<b>7.6</b>	<b>10.9</b>	<b>8.6</b>	<b>13.3</b>	<b>12.6</b>	<b>11.3</b>
Electric and thermal energy, gas and hot water production, transport and distribution	7.3	10.3	7.9	12.4	11.6	10.3
Water collection, treatment and distribution	0.3	0.6	0.7	0.9	1.0	1.0

Source: Romanian Statistical Yearbook, 1997

Table1-5 Gross domestic product by categories by resources

%	1991	1992	1993	1994	1995	1996
Agriculture	18.3	18.6	20.6	19.4	19.3	18.7
Sylviculture, fishing, forestry and hunting	0.5	0.5	0.4	0.5	0.5	0.4
Industry	37.9	38.3	33.8	36.2	32.9	34.2
Construction	4.4	4.8	5.2	6.5	6.6	6.9
Trade	13.5	14.3	10.3	8.2	10.5	10.1
Transport	5.7	7.6	8.8	7.5	6.3	6.6
Post and telecommunications	1.0	0.9	1.3	1.3	1.4	2.1
Financial, banking and insurance activities	2.6	5.3	5.1	4.8	5.0	4.1
Real estate and other services	3.9	4.3	4.2	4.3	4.8	5.5
Public administration and defence, compulsory social assistance	3.1	3.4	3.1	3.2	3.7	3.4
Education	2.8	2.7	2.5	2.5	2.6	2.1
Health and social assistance	2.3	2.1	1.8	1.9	1.8	1.5
Gross domestic product - total (billion lei)	2,203.9	6,029.2	20,035.7	49,773.2	72,135.5	108,390.9
Gross domestic product per capita (lei)	95,057	264,565	880,487	2,189,697	3,180,444	4,794,441
The weight of private sector in gross domestic product (%)	23.6	26.4	34.8	38.9	45.3	52.5

Source: Romanian Statistical Yearbook, 1997

Table1-6 Consumer price indices

	Previous year = 100						
	1991	1992	1993	1994	1995	1996	1997
Total	270.2	310.4	356.1	236.7	132.3	138.8	254.8
Food goods	286.2	336.6	348.9	236.2	131.9	136.4	-
Non-food goods	267.8	294.2	369	232.8	129.6	139.1	-
Services	235.7	280.4	340.3	250.8	142.7	146.9	-

Source: Romanian Statistical Yearbook, 1997

Table1-7 Commercial exchange rate

Year	1992	1993	1994	1995	1996	1997	1998
The exchange rate with the U.S (for \$)	308	760	1,655	2,033	3,085	7,168	8,383 *

Source: Country Report 2nd quarter 1998

\* April 17th 1998

Table1-8 Employment by activities of national economy (end of year)

thou persons	1991	1992	1993	1994	1995	1996
Total	10,786	10,458	10,062	10,011	9,493	9,379
Agriculture	3,116	3,362	3,537	3,561	3,187	3,249
Sylviculture, forestry and hunting	89	81	77	86	78	71
Industry	3,803	3,301	3,030	2,882	2,714	2,741
Mining and quarrying	277	272	259	256	250	250
Manufacturing	3,372	2,865	2,606	2,456	2,293	2,302
Electric and thermal energy, gas and water	154	164	165	170	171	189
Construction	501	579	574	563	479	475
Trade	699	754	585	636	865	772
Hotels and restaurants	213	175	131	136	123	116
Transport	594	556	497	462	458	448
Post and telecommunications	96	93	95	94	98	99
Financial, banking and insurance activities	44	57	66	59	71	71
Real estate and other services	421	441	417	438	324	257
Public administration and defence; compulsory social assistance	99	113	117	125	131	125
Education	426	432	432	437	437	441
Health and social assistance	311	306	308	333	333	337
Other activities of the national economy	374	208	196	199	195	177

Source: Romanian Statistical Yearbook, 1997

Table1-9 Monthly average salary income (April 1998)

	lei
Total Economy	1,045,498
Agriculture	721,181
Industry - total	1,107,938
Mining and quarrying	1,740,446
Wood industry	725,170
Pulp, paper and cardboard	1,021,699
Transport and store	1,239,273
Financial, banking and insurances institutions activities	3,414,473
Public administration	1,163,170

Source: Monthly Statistical Bulletin, no.4 1998

## 2. Olt County

Table 2-1 Population at 1st July (Olt County)

	1980	1985	1990	1995	1996
TOTAL	531,972	530,996	530,425	519,030	517,597
Urban (%)	26.5	30.8	39.1	39.8	39.9
Rural (%)	73.5	69.2	60.9	60.2	60.1

Source: The Statistic Summary of Olt, 1997

Table 2-2 Employment by branches (Olt County)

thou persons	1980	1985	1990	1995	1996
Total	250.3	245.6	247.2	208.4	205.8
Agriculture	123.6	107.3	107.6	104.1	106.6
Silviculture, forestry and hunting	0.7	0.8	0.7	0.5	0.5
Industry	60.6	67.3	72.7	39.3	40.9
Constructions	18.6	21.9	14.3	9.6	9.3
Trade	10.3	10.8	12	16.9	11.8
Transports	13	12.1	11.9	6.8	6.6
Post and communications	1.5	1.5	1.8	1.7	1.6
Financial, banking and insurance activities	0.5	0.6	0.9	1.2	1.3
Public administration and defence, compulsory social assistance	1.3	1.2	1.5	2.7	2.6
Education	8.7	8.7	9.1	8.5	8.5
Health and social assistance	4.8	5.1	5.4	5.9	6.1

Source: The Statistic Summary of Olt, 1997

Table 2-3 Monthly average salary income (Olt County)

lei	1995	1996
Total	208,305	313,561
Agriculture	208,305	313,561
Silviculture, forestry and hunting	177,383	249,429
Fishing and fish breeding	188,782	299,122
Industry	230,030	
Mining and quarrying	303,281	450,491
Manufacturing	220,403	355,886
Electric and thermal energy, gas and water	285,825	424,673
Constructions	203,518	295,963
Trade	197,588	239,710
Hotels and restaurants	128,131	193,937
Transports	241,765	397,730
Post and communications	230,958	352,001
Financial, banking and insurance activities	369,248	626,552
Real estate and other services	180,545	255,974
Public administration and defence, compulsory social assistance	205,378	264,920
Education	189,617	281,507
Health and social assistance	173,334	237,934
Other branches of the national economy	137,883	196,980

Source: The Statistic Summary of Olt, 1997



Table 2-4 Total land area by use (Olt County)

Thous hectares	1995	1996
<b>Total area</b>	<b>549.8</b>	<b>549.8</b>
<b>Agricultural area</b>	<b>442.4</b>	<b>442.5</b>
Arable	383.1	383.2
Pastures	35.3	35.4
Meadows	0.8	0.8
Vineyards and nurseries	10.5	10.5
Orchards and nurseries	12.6	12.5
<b>Forests</b>	<b>57.7</b>	<b>57.7</b>
<b>Area with waters and ponds</b>	<b>17.9</b>	<b>17.9</b>
<b>Other areas</b>	<b>31.8</b>	<b>31.8</b>

Source: The Statistic Summary of Olt, 1997

Table 2-5 Cultivated area (Olt County)

Thou hectares	1980	1985	1990	1995	1996
<b>Cereals for grains</b>	<b>258.0</b>	<b>229.0</b>	<b>251.9</b>	<b>303.2</b>	<b>247.3</b>
Wheat and rye	81.6	82.4	101.0	138.8	74.6
Barley and two-row	33.0	30.3	34.9	23.7	17.9
Maize	142.2	103.7	113.4	138.6	151.2
<b>Vegetables for grains</b>	<b>4.3</b>	<b>13.0</b>	<b>5.4</b>	<b>1.2</b>	<b>1.9</b>
Pea	1.1	4.0	2.0	0.8	1.2
Green bean	3.2	8.4	3.0	0.4	0.6
<b>Oil plants</b>	<b>50.3</b>	<b>50.8</b>	<b>32.7</b>	<b>35.7</b>	<b>58.5</b>
Sunflower	30.7	32.5	24.5	34.3	56.3
Soy	15.3	11.9	5.9	1.0	1.5
<b>Plants for industrization</b>	<b>17.5</b>	<b>15.8</b>	<b>10.1</b>	<b>4.0</b>	<b>3.8</b>
<b>Medicinal and aromatic plants</b>	<b>2.7</b>	<b>3.6</b>	<b>2.5</b>	<b>1.7</b>	<b>1.7</b>
<b>Vegetables</b>	<b>17.5</b>	<b>13.0</b>	<b>11.6</b>	<b>8.3</b>	<b>9.1</b>
tomatoes	6.0	4.8	3.7	2.2	2.6
Dry onion	2.2	1.0	1.4	0.9	0.9
Cabbage	1.1	0.6	1.2	1.5	1.4
<b>Fodder plants</b>	<b>24.4</b>	<b>36.0</b>	<b>65.0</b>	<b>25.4</b>	<b>21.1</b>

Source: The Statistic Summary of Olt, 1997

Table 2-6 Agricultural production (Olt County)

Thou tons	1980	1985	1990	1995	1996
<b>Cereals grains</b>	<b>900.4</b>	<b>1,103.7</b>	<b>894.7</b>	<b>1,106.9</b>	<b>607.4</b>
Wheat and rye	256.3	332.5	392.9	519.5	76.4
Barley and two-row barley	104.8	132.7	143.1	88.1	30.6
Maize	538.4	626.1	355.1	495.7	498.4
<b>Leguminous crops for grains</b>	<b>2.2</b>	<b>18.1</b>	<b>3.1</b>	<b>2.6</b>	<b>5.4</b>
Sun flower	40.4	77.3	31.8	52.4	71.0
Soybean	9.9	17.9	5.0	1.7	1.1
<b>Sugar beet</b>	<b>296.6</b>	<b>379.6</b>	<b>147.1</b>	<b>49.2</b>	<b>51.9</b>
<b>Potatoes</b>	<b>30.1</b>	<b>56.6</b>	<b>22.3</b>	<b>18.2</b>	<b>20.4</b>
<b>Vegetables - total</b>	<b>190.9</b>	<b>241.4</b>	<b>96.3</b>	<b>111.9</b>	<b>99.4</b>
Tomatoes	104.8	151.0	42.4	43.8	37.9
Dry onion	10.8	10.4	9.1	7.4	6.0
Cabbage	32.5	22.6	20.8	27.7	23.7
<b>Fruit</b>	<b>68.5</b>	<b>77.7</b>	<b>37.2</b>	<b>27.8</b>	<b>48.8</b>
Plums	42.6	46.2	17.1	17.8	29.1
Apples	7.9	11.6	11.2	5.5	10.7
Pears	2.7	2.1	0.8	0.6	0.9
Peaches	1.1	4.0	2.1	0.9	1.4
Cherries and sour cherries	2.1	2.0	1.0	0.9	2.8
Apricots and ungrafted apricots	1.2	1.9	2.0	0.8	2.3
Nuts	1.5	1.0	0.8	0.3	0.5

Source: The Statistic Summary of Olt, 1997

**Table 2-7 Structure of industrial production by activities(Olt County)**

	mill lei 1995 prices	%
<b>Total</b>		<b>100.0</b>
<b>Mining and quarrying</b>		<b>0.1</b>
Energy		0.1
Nonenergy		0.1
<b>Manufacturing</b>		<b>97.6</b>
Food and beverage tobacco industry		6.9
Textile and textil products		2.4
Textile , fur and leather wearing apparel		0.8
Leather goods and footwear		0.9
Wood processing(excluding furniture)		0.1
Publishing house , polygraphy and recordings on supports		0.1
Chemicals and synthetic and artificial fibres		5.7
Rubber and plastics processing		0.8
Other nonmetallic mineral products		9.5
Metallurgy		57.6
Metallic constructions and metal products		1.1
Machinery and equipments		2.2
Electric machinery and appliances		2.4
Means of road transport		3.9
Other means of transport		2.9
Furniture and other nonclassified		0.3
Wastes recovering		0.1
<b>Electric and thermal energy , gas and water</b>		<b>2.3</b>

Source: The Statistic Summary of Olt, 1997

### 3. Dolj County

Table 3-1 Population at 1st July (Dolj County)

1989	1990	1991	1992	1993	1994	1995	1996	1997
772,451	776,161	774,082	761,219	759,605	758,895	756,318	751,938	749,311

Source: The Statistic Summary of Dolj, 1997

Table 3-2 Employment by branches (Dolj County)

(thou persons)	1989	1990	1991	1992	1993	1994	1995	1996
Total	355.9	360.5	355.2	344.0	336.3	332.3	301.7	300.2
Agriculture	132.7	137.3	134.1	148.8	155.6	158.2	144.7	147.2
Silviculture, forestry and hunting	0.9	1.0	0.9	1.3	1.2	1.1	2.3	1.4
Industry	110.1	109.9	98.0	80.2	71.0	67.7	61.0	65.2
Mining and quarrying	3.2	3.0	2.8	2.3	2.5	2.4	2.4	2.3
Manufacturing	97.0	97.2	86.7	69.9	61.1	56.8	50.9	54.5
Electric and thermal energy, gas and water	9.9	9.7	8.5	8.0	7.4	8.5	7.7	8.4
Constructions	21.0	18.9	14.9	16.2	13.7	21.6	13.4	13.5
Trade	16.5	16.2	20.3	22.1	24.3	16.0	21.4	16.8
Hotels and restaurants	3.2	3.1	3.5	4.5	2.1	1.7	4.8	3.8
Transports	22.2	22.8	22.1	19.1	15.8	14.3	12.1	12.7
Post and communications	2.1	2.7	2.7	2.7	2.6	2.6	2.9	2.9
Financial, banking and insurance activities	1.1	1.3	1.4	1.3	1.4	1.4	1.7	1.8
Real estate and other services	15.9	14.4	14.3	14.0	13.7	14.7	6.0	5.4
Public administration and defence, compulsory social assistance	1.3	1.5	2.4	2.9	3.3	3.6	3.6	3.4
Education	12.5	15.0	16.5	15.0	14.7	13.6	13.4	13.3
Health and social assistance	8.8	9.1	9.1	9.6	10.2	9.8	9.4	9.6
Other branches of the national economy	7.6	7.3	15.0	6.3	6.7	6.0	5.0	3.2

Source: The Statistic Summary of Dolj, 1997

Table 3-3 Monthly average salary income (Dolj County)

lei	1995	1996
Total	213,659	319,341
Agriculture	163,041	233,622
Silviculture, forestry and hunting	147,168	260,874
Fishing and fish breeding	161,299	192,970
Industry	238,083	353,621
Mining and quarrying	293,649	415,163
Manufacturing	216,075	321,574
Electric and thermal energy, gas and water	357,429	529,416
Constructions	208,653	306,459
Trade	177,531	283,382
Hotels and restaurants	116,973	148,724
Transports	269,180	372,864
Post and communications	246,022	377,844
Financial, banking and insurance activities	375,887	620,236
Real estate and other services	215,196	323,491
Public administration and defence, compulsory social	205,128	272,960
Education	215,463	317,116
Health and social assistance	175,362	258,524
Other branches of the national economy	172,305	265,362

Source: The Statistic Summary of Dolj, 1997

Table 3-4 Total land area by use (Dolj County)

Thou hectares	1989	1990	1991	1992	1993	1994	1995	1996
Total area	741.4	741.4	741.4	741.4	741.4	741.4	741.4	741.4
Agricultural area	590.3	590.1	590.1	583.9	584.0	588.7	588.6	588.6
Arable	485.4	484.7	484.7	480.8	482.3	485.3	485.6	485.7
Pastures	72.9	74.1	74.1	68.0	67.1	68.8	71.4	71.5
Meadows	2.9	2.9	2.9	2.8	2.6	2.7	2.8	2.8
Vineyards and nurseries	16.2	16.0	16.0	20.5	20.5	20.4	19.0	19.0
Orchards and nurseries	12.9	12.4	12.4	11.9	11.5	11.5	9.8	9.7
Forests	81.5	81.5	81.5	81.5	81.5	81.4	81.5	81.5
Area with waters and ponds	25.2	25.2	25.2	25.2	25.2	22.5	22.6	22.6
Other areas	44.3	44.6	44.6	50.7	50.6	48.9	48.8	48.8

Source: The Statistic Summary of Dolj, 1997

Table 3-5 Cultivated Area (Dolj County)

Thou hectares	1989	1990	1991	1992	1993	1994	1995	1996
Cereals for grains	302.6	305.3	341.5	319.6	364.2	384.3	371.7	274.8
Wheat and rye	125.5	128.4	137.2	102.9	165.0	178.6	177.4	72.1
Barley and two-row	30.5	32.7	49.2	23.3	28.2	36.8	17.7	12.1
Oats	0.8	1.4	1.7	3.8	5.8	3.5	0.8	1.2
Maize	139.6	138.3	152.2	189.0	164.6	165.2	175.3	188.6
Rice	6.2	4.5	1.2	0.6	0.6	0.2	0.1	0.5
Vegetables for grains	17.2	4.0	1.2	1.4	1.2	1.1	1.5	2.2
Pea	3.1	2.3	0.8	0.5	0.5	0.5	0.9	1.1
Green bean	11.5	1.5	0.4	0.8	0.7	0.5	0.5	0.9
Chick Pea	2.4	0.1	-	0.0	-	0.0	0.1	0.2
Textile plants	1.1	-	-	-	-	-	-	-
Oil plants	80.7	40.9	43.5	46.5	38.7	26.0	41.7	66.0
Sunflower	38.2	31.8	38.7	42.1	36.1	24.2	39.4	61.9
Rape	0.4	0.5	0.4	-	-	-	0.1	-
Soy	34.0	7.2	3.4	4.2	2.3	1.4	1.8	3.8
Flax for oil	5.1	1.2	0.9	0.1	0.2	0.1	-	-
Castor-oil plant	3.1	0.2	-	-	-	-	-	-
Plants for industrization	21.0	12.1	14.6	10.6	6.5	8.1	7.8	6.6
Sugar beet	14.5	9.1	12.3	8.3	2.5	4.0	3.4	1.8
Tabacco	5.7	2.6	2.0	2.1	3.9	3.9	4.3	4.7
Sorghum for broom	0.8	0.4	0.2	0.1	0.2	0.2	0.2	0.2
Medicinal and aromatic plants	4.3	2.7	1.2	2.6	0.5	0.4	0.4	0.9
Potatoes	7.4	5.0	1.9	2.8	3.9	3.9	3.8	4.5
Early summer potatoes	3.9	3.2	1.3	1.5	2.2	2.6	2.4	2.7
Autumn	3.5	1.8	0.6	1.3	1.7	1.3	1.4	1.7
Vegetables	13.5	10.4	9.0	12.5	11.9	10.6	11.2	11.8
Tomatoes	4.7	3.4	3.8	4.6	3.8	3.2	3.4	3.5
Dry onion	1.0	1.0	0.8	1.7	1.5	1.5	1.5	1.7
Dry garlic	0.6	0.3	0.3	0.6	0.6	0.7	0.7	0.9
Cabbage	0.7	0.9	0.8	1.5	1.4	1.6	1.7	1.6
Peppers	1.2	1.2	0.5	1.0	0.7	0.6	0.5	0.7
Cucumber	0.7	0.3	0.1	0.3	0.3	0.2	0.3	0.2
Root crops	0.5	0.3	0.3	0.4	0.6	0.6	0.6	0.7
Rod pea	2.3	2.0	1.5	0.9	0.8	0.9	0.8	0.6
Rod bean	0.3	0.3	0.4	0.7	0.6	0.6	0.7	0.9
Green and yellow melons fodder	3.6	3.6	7.5	7.7	7.5	7.3	8.3	8.8
Fodder plants	60.7	92.6	49.4	62.9	42.4	36.4	31.7	36.8
Annual plants for hay and green	31.8	19.3	14.6	12.4	14.4	12.2	9.8	13.8
Plants for silage	3.1	41.7	7.9	30.1	6.7	3.9	2.3	5.5
Strawberry	0.8	0.5	0.2	0.1	0.1	0.0	0.0	0.0
Vineyard	13.9	14.7	13.5	14.6	16.2	16.7	16.6	17.3

Source: The Statistic Summary of Dolj, 1997

Table 3-6 Agricultural production (Dolj County)

Thou tons	1989	1990	1991	1992	1993	1994	1995	1996
<b>Cereals grains</b>	<b>1,118.5</b>	<b>1,169.3</b>	<b>1,345.3</b>	<b>696.8</b>	<b>362.4</b>	<b>1,315.1</b>	<b>1,115.6</b>	<b>622.9</b>
Wheat and rye	529.9	509.8	394.4	219.1	255.7	545.3	398.5	75.6
Barley and two-row barley	167.1	143.5	189.5	72.0	44.3	131.0	56.8	21.0
Oats	2.6	2.9	3.5	7.5	4.2	4.7	1.2	0.9
Maize	410.3	507.2	756.4	397.4	57.1	633.6	656.1	525.0
Rice	8.5	5.8	1.5	0.7	1.1	0.4	0.0	0.5
Leguminous crops for grains	11.3	2.2	1.0	1.3	1.3	1.0	2.2	1.5
Fibre crops - cotton	0.0							
Oilseed crops	66.1	43.8	57.9	48.2	16.6	43.1	56.7	72.9
Sugar beet	308.7	178.3	308.3	104.2	8.3	84.1	50.1	20.7
Tabacco	3.7	2.2	3.0	2.1	3.7	5.7	5.8	5.4
Genista	0.4	0.3	0.2	0.1	0.2	0.1	0.2	0.2
Medicinal and aromatic plants	3.4	1.9	0.7	0.6	0.1	0.2	0.0	0.1
Potatoes	53.8	28.5	17.9	28.3	21.8	38.5	39.1	37.4
<b>Vegetables - total</b>	<b>173.3</b>	<b>124.6</b>	<b>119.4</b>	<b>147.7</b>	<b>101.5</b>	<b>120.6</b>	<b>136.1</b>	<b>132.7</b>
Tomatoes	80.5	67.7	71.1	67.4	40.5	47.2	48.4	49.3
Dry onion	13.6	10.1	6.9	16.2	5.7	12.0	13.8	12.0
Dry garlic	1.6	0.9	1.5	2.8	0.7	2.7	3.7	3.4
Cabbage	27.6	19.0	17.4	25.5	27.0	28.7	33.7	33.6
Green peppers	7.0	5.5	3.0	7.7	4.1	5.5	5.1	6.0
Cucumber	5.8	6.0	6.4	11.8	10.2	3.0	14.0	12.1
Edible roots	5.7	2.0	2.8	3.8	3.1	6.2	5.4	5.5
Pears	12.6	7.3	5.1	3.6	1.8	3.8	3.8	1.5
Beans	1.6	0.9	1.0	1.9	2.6	1.8	2.6	2.4
Water melons and melons	9.7	52.4	119.2	98.2	48.8	103.8	101.4	94.7
Grapes	40.1	19.2	70.8	51.4	47.5	71.7	69.5	76.7
<b>Fruit</b>	<b>43.9</b>	<b>26.4</b>	<b>24.5</b>	<b>28.8</b>	<b>21.0</b>	<b>16.1</b>	<b>18.9</b>	<b>32.5</b>
Apples	20.7	12.6	8.7	16.6	9.8	5.2	9.1	13.6
Pears	0.9	0.9	0.8	0.9	0.5	0.5	0.7	1.0
Plums	6.3	5.8	7.8	6.9	6.3	6.7	4.9	11.0
Apricots and ungrafted apricots	3.2	2.6	1.6	1.2	1.0	1.5	0.7	2.8
Peaches	10.1	2.2	4.0	1.3	2.1	0.7	2.2	1.8
Cherries and sour cherries	1.1	0.8	0.7	1.0	0.7	0.6	0.6	1.2
Nuts	0.2	0.2	0.1	0.2	0.1	0.2	0.2	0.4
Strawberries	0.7	0.6	0.4	0.2	0.1	0.1	0.0	0.1

Source: The Statistic Summary of Dolj, 1997

Table 3-7 Structure of industrial production by activities in 1997 (Dolj County)

Indicator	Industrial production structure (%)
Total	100
Natural gas and oil extraction (excluding prospections)	2.3
Food and drink industry	19.2
Tobacco industry	1.2
Textiles	0.7
Leather, fur and textiles coats industry	2.2
Shoe and leather industry	0.4
Wood processing industry(excluding the furniture production)	0.6
Publishing polygraphy and recording reproduction on supports	0.5
Artificial fibres and chemical industry	10.7
Other no-metallic products industry	1.3
Metallurgical industry	0.6
Metallic buildings and metal machine products Industry (excluding equipment, installation)	1.2
Equipment and machine industry	1.8
Electric machine and devices	6.0
Car industry	25.6
Other transportation industry	2.4
Furniture industry	0.9
Recyclable materials	
Waste recovery	0.2
Gas, water, thermic and electric energy production and transport	20.8
Water treatment and distribution	1.2

Source: The Statistic Summary of Dolj, 1997

## Appendix C-2 Results of the socioeconomic interview survey regarding national forests

### Result of the interview survey - 1998 - Northern zone

#### Function of wood production

The most frequent species mentioned are as follows: *Quercus* spp., *Robinia* spp., *Populus* spp., while *Salix* spp. and *Carpinus* spp. or *Betula* spp. are less frequent mentioned. The evaluated mature age of *Quercus* spp. was 40-70 years which is smaller than the real one.

The initial number of seedlings per hectare was appreciated as ranging from 2,000 up to 7,000. The number of trees at cutting age ranges from 100 to 800 per hectare.

The data regarding the evaluated mature age, initial number of seedlings, number of trees at cutting age are recorded according to the species in the table below.

The prices are estimated according to the species, destination (firewood and wood industry) and the results are shown in the table below, too.

Species	Silvicultural system		Price of wood (thousand Lei)		
	Mature age (years)	Initial number of trees /ha	Final number of trees /ha	Fire wood	Wood industry
<i>Quercus</i> spp.	40-70	2,000-7,000	100-800	120-180	176-300
<i>Robinia</i> sp.	18-60	2,500-3,500	500-1,000	150	172-200
<i>Populus</i> spp.	20-50	400-3,000	300-600	110	140-150
<i>Salix</i> spp.					150

Adequate terrain is a hilly slope in case of *Quercus* spp., plain and sandy soil for *Robinia* and *Populus* spp.

According to the silvicultural systems the work conditions are appreciated as medium.

#### Function of fire wood production

The consumption of firewood is 4 to 5 m<sup>3</sup> per family. In the past, the consumption was about 3 m<sup>3</sup>, so that it increased.

In the past the families used coal, and when provisions finished they depended on firewood as well as on the heating. Charcoal is produced in the northern mountainous region, but as it is expensive, they do not use it.

The most utilised wood is that of *Quercus* spp., *Robinia pseudoacacia* and other species that can be bought close to the national forests. The quality and quantity is similar to those sold in the past.

The price of firewood is 120 thousand Lei for *Populus* spp., 150 thousand Lei for *Robinia* spp. and 180 thousand for *Quercus* spp., which is referred to as very expensive.

#### Function of subproducts in the forest

The subproducts mentioned are: mushrooms, medicinal plants, fruits and grass and bush for fodder.

Particularly there are utilising the mushrooms. There are recorded the answers that the production of subproducts decreased because of decline phenomenon of the forest, on the other side there is also recorded the situation that there is no such influence in the Olt County. The area of the production covers

all the forests including the hilly districts.

The villagers are utilising it, on the other side RNP is harvesting and selling it.

#### Function of water resource conservation

About 57 % of the interviewees have no knowledge about it. Anybody, who feels a benefit of it, is particularly thinking of the river band forest as they are practically utilising it as water supply resource for the Mersey.

#### Function of soil conservation

This function is evident in two places: where landslide occurred, and the river band forest behind the Olt river dam. On the other hand, there is a good perception of this function as the forests exist nearby the community.

#### Function of wind break

There are not many answers regarding the topic. About 86 % of interviewees do not feel the necessity of the function. Due to the topography and climate, forests are not prone to wind damage. In the district of Pitesti in the Olt County people are aware of this function.

#### Utilization of hunting

In the *Quercus* forest on the hilly district the perception of the effect of hunting is evident. AGVPS and RNP are managing and making a profit on it. Objective animals are fox, pheasant, wild boar, deer and hare.

#### Utilization of grazing in the forest

It does not occur because it is prohibited by law.

#### Forestry labour

The employment of the national forest are carrying out the afforestation, nursery work, felling of the wood, gathering fruits, and support work for hunting.

The work type is daily employment mainly, the wage is 20 to 50 thousand Lei, average is 30 thousand Lei using chainsaw and manual tools. The opportunity of forestry work is increasing, and is expected in the near future, too.

#### Coordination of the regional development

The contribution is connected with afforestation in the felled area, degraded area, and maintenance work of the road and valley.

The influence of decline phenomenon results in increasingly scarce trees and poor quality of wood, as well as the reducing of agricultural crops. Regarding the matter of request and co-ordination they hope that RNP will solve the afforestation and tending on the degraded area, the improvement and arrangement of river band forest, and establishment of water supply system for community. More financial funds are required either.

## Result of the interview survey - 1998 - Central zone

### Function of wood production

The species mentioned are as follows: *Quercus* spp., *Robinia* spp., *Populus* spp., *Salix* spp., *Pinus* spp., *Fraxinus* spp., *Fagus* spp., *Acer* spp. and *Carpinus betulus*. The main species are: *Quercus* spp., *Robinia* sp. and *Populus* spp.

The answers regarding the silvicultural system are recorded according to the species in the table below.

The items are the same with Northern and Southern zone.

Species	Mature age (years)	Silvicultural system		Price of wood (thousand Lei)	
		Initial number of trees /ha	Final number of trees /ha	Fire wood	Wood industry
<i>Quercus</i> spp.	100-120	6,700	600-800	110-133	150-300 (200)
<i>Robinia</i> sp.	25	5,000	700-900	100-133	160-200 (180)
<i>Populus</i> spp.	25	625	300-400	133	180
<i>Salix</i> spp.					180
<i>Fraxinus</i> spp.	60	6,700		110	160

Concerning *Quercus* spp., there is a case of selling for wood industry outside the county at the price of 225 to 240 thousand Lei for laminated wood or board. There is a case of selling by 800 thousand Lei for special users, too.

The difficulty of silvicultural technique is considered particularly for *Quercus* spp.

### Function of fire wood production

The consumption of firewood is 3 to 4 m<sup>3</sup> per year for a family. The trend increased with 20-40 % in comparison with the past. Between 1980 and 1990 the provisions of firewood were restricted, actually they are supplying from declined trees, too as they can be obtained more easily. There are utilized salvage cut trees.

The price of firewood is increasing in spite of the quality decreasing. The price of wood ranges from 133 to 150 up to 170 thousand Lei.

In the poor villages they are utilizing the dry cane of sunflower.

### Function of subproducts in the forest

The subproducts utilized are: firstly, fruits and medicinal plants and secondly, mushrooms. The grass as well as the branches of *Robinia* sp. are utilized as fodder. In Bals and Falcoiu in Olit County it is RNP which harvests the fruits and exports them obtaining income. A few quantity is utilized by villagers.

High forest of *Quercus* spp. is suitable for subproducts, but as the forest is affected by the decline phenomenon, fruit production is decreasing. In Bals district there are 100 ha and it is desired more than 1,200 ha or 2,000 ha.

### Function of water resource conservation



About 68 % of the interviewees have no knowledge about it.

Practically there are districts where water is used and water resource forest is clearly referred to as a benefit by the villagers. Only one of the mayors and one of the forest rangers are conscious of the function within the whole area of the district forest.

#### Function of soil conservation

On the slopes of the hilly district forest surrounding the community settlements as land slided, the whole degraded area or moreover, on the river band forest of the Olt river, people are consciousness of the soil conservation function.

There are some forests planted with *Robinia*, *Elaeagnus* and *Quercus* spp. And within other areas there are established forest belts of 200 m wide on the farmland.

On the other hand, about 37 % of the interviewees are not aware of it.

#### Function of wind break

About 89 % of the interviewees have no knowledge of it.

In Radovan and Scornicesti districts the wind break function is expected practically, the forests consist of *Robinia* and *Quercus* spp.

#### Utilization of hunting

All the interviewees recognized that hunting is done in the neighbouring forests. It is done in all the seasons, particularly in winter much more frequently.

As for the forest cover type it is considered that broad-leaved forest such as *Quercus* spp., *Robinia* sp. are adequate, but they are not particularly required.

Regarding the forest size it is considered that more than 250 ha or 1,000 ha are suitable but it is not specially required.

Objective animals are as follows: fox, wild boar, rabbit, pheasant, deer, fallow deer (*Cervus dama*) and badger.

AGVPS and RNP are managing game funds and making profits on it.

#### Utilization of grazing in the forest

It does not occur but scarcely because it is prohibited by law since 1997.

The watchmen accompany the farmers' animals grazing on the harvested farm and meadows. But because of the bad manners there are a few cases of grazing in the forest.

#### Forestry labour

The employees of the national forest carry out the following operations: felling, afforestation, silvicultural works, nursery, medical (chemical) spraying, gathering medical plants and fruits, collecting of seeds, stacking of fire wood etc.

The type of work is daily employment, using chain saw and manual tools mainly.

The labour wage is 20 to 50 thousand Lei, that is almost 30 thousand Lei level. There are a few cases of voluntary work, it includes a merit of obtaining fire wood more cheaply. The desire of forestry work is increasing.

### Coordination of the regional development

Regarding the case of contribution there are listed the following: improvement of road, support of afforestation work for monastery and degraded area, and levy fees by making hunting chalets available.

The influence of decline phenomenon appeared increasing in case of fire wood provisions referred to as positive; on the other side, a negative view appeared as the ecological equilibrium was broken and bad conditions for regeneration appeared due to undesirable climatic condition and drought which reduced the honey yield due to low florescence of *Robinia* sp., reduced the agricultural crops, hunting opportunities, and resulted in erosion.

As for the matter of request and co-ordination, the road construction and improvement, afforestation on degraded area, good forest management and protection work, support of water supply system for community, improvement of the employment in the forestry are hoped for the RNP. Almost all the interviewees desired the increasing of fund for the above mentioned activities.

## Result of the interview survey - 1998 - Southern zone

### Function of wood production

The species mentioned are as follows: *Quercus* spp., *Robinia* sp., *Populus* spp., *Salix* spp., *Fraxinus* spp., and *Tilia* spp. The main species are: *Quercus* spp., *Robinia* spp., and *Populus* spp.

The answers regarding the silvicultural system are recorded according to the species in the table below.

The items are the same with Northern and Central zone.

Species	Mature age (years)	Silvicultural system		Price of wood (thousand Lei)	
		Initial number of trees /ha	Final number of trees /ha	Fire wood	Wood industry
<i>Quercus</i> spp. (Average)	60-120 (100)	1,600-7,000 (7,000)	250-2,000 (700)	110-200 (200)	170-500 (140)
<i>Robinia</i> sp. (Average)	20-35 (30)	1,000-5,000 (5,000)	500-3,000 (1,500)	110-180 (130)	160-220 (170)
<i>Populus</i> spp. (Average)	20-25 (20)	400-660 (600)	250-600 (400)	80-160 (110)	130-200 (160)
<i>Fraxinus</i> spp.	120	4,400	220		150
<i>Tilia</i> spp.	60	4,400	880		

The number of trees in case of *Robinia* sp., reflects a high density, more than in the Northern and central zone.

The difficulty of silvicultural technique is considered in case of *Quercus* spp. and *Robinia* sp. in a few parts of answers, but it is not considered difficult in case of *Populus* spp.

### Function of fire wood production

The consumption of firewood is 4 to 5 m<sup>3</sup> per family. The trend has not changed in many districts, but in case of some districts the consumption increased with 20-40 % in comparison with the past. Between 1980 and 1990 the provisions of fire wood was restricted. The most used is *Robinia* sp., but they also use *Populus* spp., *Quercus* spp. as well as branches of *Salix* spp.

The decline phenomenon does not influence the provisions of fire wood so much as it seems to be "decreased" for some and "increased" for others. As for the quality it has been appreciated as decreased but there is no problem for using firewood.

The price of wood ranges from 80 to 200 thousand Lei, the villagers' impression is that it is very high relating to the recent inflation.

### Function of subproducts in the forest

The subproducts utilized are: medicinal plants, fruits, mushrooms and particularly grass for fodder for animals in many districts.

*Urtica dioica* is used as medicinal plant and fodder, too. The utilization began in 1990, about 10 years ago. One of the forest range offices gathers and sells fruits of *Rosa canina*.

The decline phenomenon influences the reducing of medicinal plants, fruits and fodder slightly and decreasing of their quality.

These subproducts are utilized in the *Robinia* sp. forest mainly but it possible for them to be utilized in

the forests of *Quercus* spp., *Populus* spp. and *Salix* spp., too.

#### Function of water resource conservation

About 73% of the interviewees have no knowledge about it.

In the Vladila village water is used for irrigation in the vegetable gardens through the canal in the national forests from spring. In the Resca village, *Quercus* spp. covering 900 ha has the water resource conservation function.

Regarding the situation of wells, the depth is 3-4 m on the river band but the depth decreases with the altitude (when altitude increases, the depth of wells ranges from 10-20 m to 20-30 m). The wells existed on the low plateau of the plain but the drought influenced them.

#### Function of soil conservation

The *Robinia* sp. coppice forest performs the role of protection of soil conservation and climate alleviating for the neighbouring farmland on the sandy soil area.

The Danube river band forest (*Robinia* sp. and *Eleagnus* spp. forest of 15 m width; *Robinia* sp. forest of 10 m width) comprises forest belts of *Robinia* sp., *Populus* spp., *Quercus* spp. of 6,500 ha, and *Quercus* forest of 5,000 ha and perform the protection role of agricultural crops and works.

On the other side, about 27 % of interviewees are not aware of it.

#### Function of wind break

There are wide areas of sandy soil from the Danube river band to low plateau and the climate is dry, therefore the protective function of forest against strong wind is expected.

There are established forest belts of 3 m width minimum, 6-8 m width average, and 10 to 50 m is the most widely spread type. They cover more than 1,500 ha of that type of forest.

*Robinia* spp. is usually used for the forest belt. There can be encountered a two-stair forest type with the participation of *Elaeagnus angustifolia* at the edge of the belt. The height of the forest is 4 m or more, but generally it is low.

On the other hand there are the forest belts of *Populus* spp. and *Salix* spp. They are considered to perform the protection role for the farm land, crops and villagers' life depending on the wind break effect, and moreover, combined with the soil conservation and wood production. About 27 % of answers have no correspondence.

#### Utilization of hunting

About 73 % of answers recognised that hunting and fishing are done in the plain forest of *Robinia* sp., *Quercus* spp. and wind protection belts of the above mentioned species including *Populus* spp., river band forest and lakes, too.

Regarding the dimension of the forest according to the answers the big forest is suitable.

Objective animals are as follows: wild boar, deer, fox, hare, and birds like: duck, partridge etc. representative for the river band forest.

AGVPS and RNP are managing the game funds and making profits on it.

#### Utilization of grazing in the forest

It does not occur because it is prohibited by law. But very often they are grazing in the forest in spring.

#### Forestry labour

There are opportunities of work from felling to afforestation and other silvicultural activities including gathering fruits, support work for hunting, too.

They use manual tools and chain saw mainly and in a few cases they use tractor on the felling area.

The employment type is mainly daily work.

The wage is 15 to 50 thousand Lei very often it is 20 to 30 thousand Lei.

The opportunity of forestry work is increasing although some parts of the district provide a few opportunities for work; therefore, the employment opportunities are expected to increase.

#### Coordination of the regional development

The contribution is connected with construction of forest road and improvement of road, afforestation and establishment of forest belt on the river band and plateau.

The influence of decline phenomenon results in increasing of firewood supply which can be referred to as a benefit, but on the other-side, the undesirable climatic conditions, the reducing agricultural crops, wind damage, movement of sand, soil erosion and the influence for hunting are referred to as negative effects.

Regarding the matter of request and co-ordination they hope that the establishment of forest will contribute to the safety of agricultural activity, and other expectations are as follows: rent of machinery for private forest activity, increasing of demand for agrotourism.

Generally, a great part of the answers reflect the requires for more financial funds.

### Appendix C-3 防風林聞き取り調査

#### 機能類型区分および地域森林景観計画調査

聞き取り調査は、オルト県及びドルジュ県の南部地域に、居住あるいは勤務する計13名を対象に行った。その属性はRNP関係者5名、村長3名、農民5名である。その結果、地域住民が期待する防風林が明らかになった。

【防風林の有無】聞き取り調査対象者のうち約70%が国有防風林と隣接している。さらにドルジュ県オストロヴェニとアベレ・ヴィ地区では私設防風林耕地の中に設置している場合がある。国有防風林と私設防風林の両方と接している場合は38%であり、逆に両方ない場合は31%であった。国有防風林だけ設けられている場合は31%である。

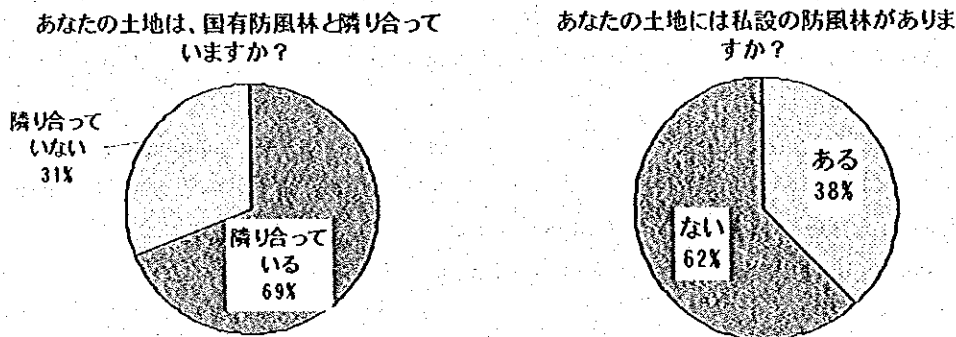

【風害体験】風害を体験した者が100%、その頻度は、「ほとんど毎年」が約77%にものぼった。国有防風林・私設防風林との隣接、非隣接にかかわらず、風害を受けている。

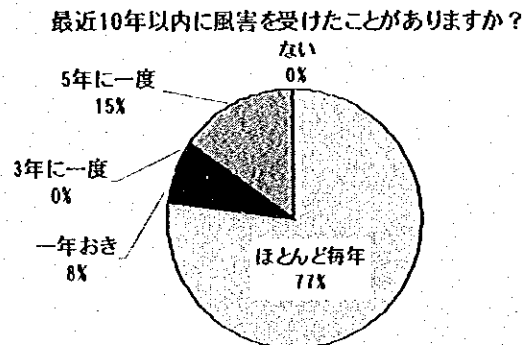

【防風林への関心度】100%の者が防風林に関心があると回答した。また防風林は防風に役立っているかという質問に対しては、地区全体から見れば100%の者が役立っていると回答したが、自分の土地に対してはほとんど役立っていないと

いうマイナス面を評価する者が少数あった。防風林の防風以外の効用について、「表土飛散防止」「木材資源」が同位で 90%を越えた。逆に最も評価が低い効用は「防霧」「その他（狩猟）」38.5%である。防風林に期待する機能は「表土飛散防止」69%、「木材資源」54%等である。

あなたは防風林の効果について考えてみたことがありますか

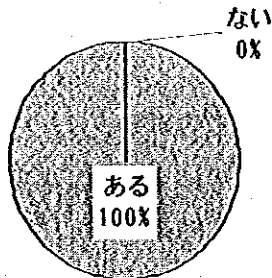

あなたの周辺にある防風林は、風害の防止に役立っていますか

★あなたの町(村)全体について考えた場合

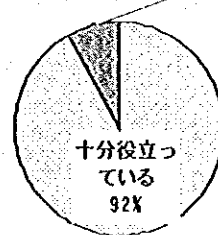

★あなた自身の土地だけについて考えた場合

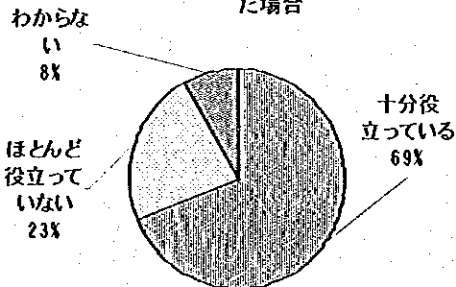

あなたの農地では、これまで防風林の保護によってどれくらいの増収効果があったと思いますか

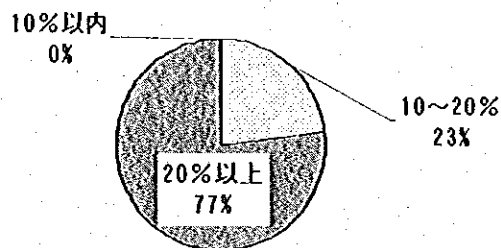

あなたの周辺にある防風林はどんな役割を果たしていますか？

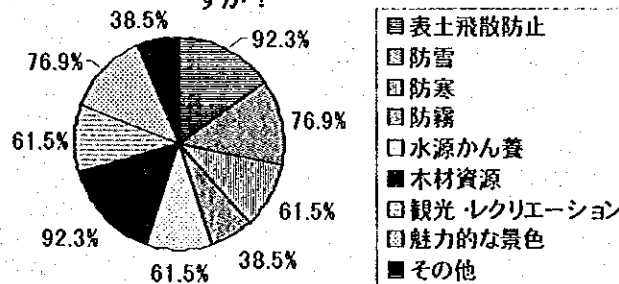

【国有防風林に対する不満と要求】

国有防風林に対して満足している者は 15%にすぎない。不満である理由としては、「防風林が途中で切れているので風の影響を受ける」39%、「防風林が全然ないので困っている」23%などが挙げられた。国有防風林は全体として多すぎるか少なすぎるかという質問に対しては、「全体をもっと増やし強化した方がよい」が 85%を占めた。また、もしも事情が許すなら、自分の土地のなかにも防風林を造成したいという者は 92%に達した。森林景観を意識した防風林を整備

するとしたら、Robinia 62%、Quercus 46%、Populus 31%などの樹種が好まれ、観光開発などの地域振興に結び付けたいという積極的な意見が出された。

国有防風林は全体として多すぎますか、少なすぎると思いますか？

