

NOTES:

FIG. N0MS-1

1. THIS DRAWING IS SHOWN A GENERAL PLAN OF MASTER PLAN STUDY IN THE CENTRAL NILE DELTA.
2. THE MASTER PLAN STUDY AREA CONSISTS OF FOUR GOVERNORATES: GHARBIA, KAFR EL SHEIKH, DAKHLIA AND DAMIETTA.
3. STUDY AREA: 799 500 Feddan (335,000 ha)

LIST OF DRAWINGS

TITLE	No.
A. MASTER PLAN STUDY: MS	
GENERAL PLAN OF MASTER PLAN STUDY IN THE CENTRAL DELTA	MS-01
B. FEASIBILITY STUDY: FS	
GENERAL PLAN OF FEASIBILITY STUDY IN THE PRIORITY AREA	FS-02
IMPROVEMENT PLAN OF RAHBEEN REGULATOR IN THE BAHR SHEBIN MAIN CANAL	FS-03
IMPROVEMENT PLAN OF MOTORIZATION FOR TERA INTAKE GATES IN THE BAHR TERA MAIN CANAL	FS-04
IMPROVEMENT PLAN OF MOTORIZATION FOR AFSMAN REGULATOR'S GATES IN THE BAHR TERA MAIN CANAL	FS-05
IMPROVEMENT PLAN OF HAMOUL PUMP STATION	FS-06
PROPOSED LOCATION OF PILOT SCHEME	FS-07
IMPROVEMENT PLAN OF EL NUR CANAL PLAN AND PROFILE (1/4)	FS-08
" " (2/4)	FS-09
" " (3/4)	FS-10
" " (4/4)	FS-11
PLAN OF CHECK GATE IN THE DELIVERY CANAL	FS-12
C. DETAILED DESIGN: DD	
IMPROVEMENT PLAN AND PROFILE (EL MASHABIK CANAL)	DD-13
CROSS SECTION (EL MASHABIK CANAL)	DD-14
IMPROVEMENT PLAN AND PROFILE (EL RABAA WEST CANAL)	DD-15
CROSS SECTION (EL RABAA WEST CANAL)	DD-16
IMPROVEMENT PLAN AND PROFILE (EL RABAA EAST CANAL)	DD-17
CROSS SECTION (EL RABAA EAST CANAL) (1/3)	DD-18
" " (2/3)	DD-19
" " (3/3)	DD-20
TYPICAL DRAWING FOR ONEPOINT LIFTING MESKA	DD-21
TYPICAL DRAWING FOR OPEN MESKA	DD-22
TYPICAL DRAWING FOR PIPE MESKA	DD-23
TYPICAL DRAWING FOR PUMP HOUSE	DD-24
MISCELLANEOUS	DD-25

JAPAN INTERNATIONAL COOPERATION AGENCY (JICA)
 MINISTRY OF PUBLIC WORKS AND WATER RESOURCES (MPWWR)

THE MASTER PLAN STUDY FOR THE IMPROVEMENT OF IRRIGATION WATER MANAGEMENT AND ENVIRONMENT CONSERVATION IN NORTH-EAST REGION OF THE CENTRAL NILE DELTA

GENERAL PLAN OF MASTER PLAN STUDY IN THE CENTRAL DELTA

DATE	MARCH, 1999	FIGURE NO.	MS-1
SANYU CONSULTANTS INC., JAPAN			



KEY MAP

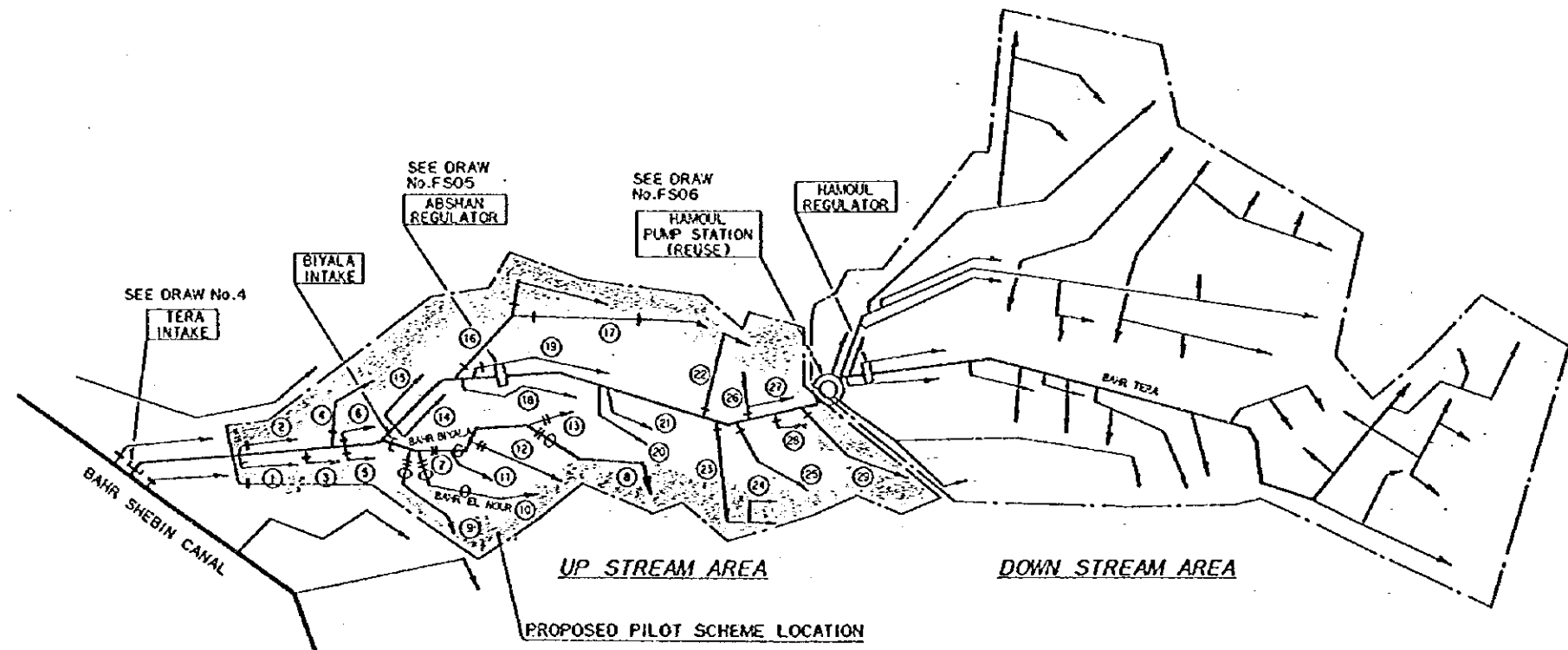

DERIVERY CANALS IN THE PRIORITY AREA(FEASIBILITY STUDY)

No.	NAME OF CANAL	AREA(F4)	No.	NAME OF CANAL	AREA(F4)
1	GANABIA No.2 RIGHT	1400	17	EBSHAN	3750
2	GANABIA No.2 LEFT	840	18	EL SHARGAMEIAH	1712
3	GANABIA No.3 RIGHT	680	19	EL NEZAM	2850
4	FODA	1650	20	MARZOUK	1000
5	GANABIA No.4 RIGHT	1440	21	GANABIA No.7 RIGHT	450
6	GANABIA No.3 LEFT	300	22	EL KAFR EL SHARKIE	1425
7	BAHR BIYA & EL NOUR	1150	23	EL BANAWAN EL ASFAL	5000
8	BAHR BIYALA	5470	24	EL BANAWAN BRANCH	2000
9	EL AGANY	850	25	RAGHEB BASHA	2050
10	BAHR EL NOUR	4000	26	EL MAHATTA	2500
11	TAMHEELAH BAHR BIYALA	1320	27	GANABIA No.7 LEFT	1150
12	EL SHORAFIA	840	28	GANABIA No.10 RIGHT	900
13	HAZEK	750	29	ZOBAA	3800
14	GANABIA No.6 RIGHT	1150		DIRECT IRRIGATION	4253
15	GANABIA No.4 LEFT	1950			
16	KOM EL HEGNA	700		F/S AREA TOTAL	56930

LEGEND

- |—|— EXISTING GATE IN THE BAHR BIYALA
- |—|— PROPOSED CHECK GATE IN THE BAHR BIYARA
- |—|— PROPOSED CHECK GATE IN PRIORITY AREA (SEE DRW.No.FS-12)

NOTES:

1. GENERAL
 - (1) THIS DRAWING IS SHOWN A GENERAL PLAN OF THE PRIORITY AREA (UPPER AREA) IN THE TERA COMMAND AREA
 - (2) THE PRIORITY AREA CONSISTS OF THREE GOVERNORATES : GHARBIA, K.F.R EL SHEHJH AND DAQHILIA.
 - (3) THE PRIORITY AREA : 62,200 Feddan (26,000 ha)
2. IMPROVEMENT PLAN OF MAJOR FACILITIES
 - (1) RAHBEEN REGULATOR ON THE BAHR SHEBIN CANAL (SEE FIG. NO. FS-03)
 - (2) TERA INTAKE GATE MOTORIZATION (SEE DRAW. NO FS-4)
 - (3) ABSHAM REGULATOR GATE MOTORIZATION IN THE TERA MAIN CANAL (SEE FIG. NO FS-5)
 - (4) IMPROVEMENT OF HAMOUL PUMP STATION (SEE FIG. NO. FS-6)
 - (5) INSTALLATION OF CHECK GATE ON THE DELIVERY CANALS (SEE FIG. NO FS-13)
3. PROPOSED PILOT SCHEME IN BAHR EL NOUR COMMAND AREA (4,000 Feddan : 1,680 ha)

JAPAN INTERNATIONAL COOPERATION AGENCY (JICA)
MINISTRY OF PUBLIC WORKS AND
WATER RESOURCES (MPWWR)

THE MASTER PLAN STUDY FOR THE IMPROVEMENT OF IRRIGATION
WATER MANAGEMENT AND ENVIRONMENT CONSERVATION IN
NORTH-EAST REGION OF THE CENTRAL NILE DELTA

GENERAL PLAN OF FEASIBILITY
STUDY IN THE PRIORITY AREA

DATE MARCH, 1999 FIGURE NO. FS-02

SANYU CONSULTANTS INC., JAPAN

NOTES :

- (1) THIS DRAWING IS SHOWN THE TERA INTAKE GATE MOTORIZATION IN THE TERA MAIN CANAL.
- (2) THE LOCATION OF INTAKE IS INDICATED ON THE FIGURE (NOMS-1)
- (3) MAJOR DIMENSIONS, EXISTING GATE MOTORIZATION GATE OPERATION AND MISCELLANEOUS :
 - a) THE EXISTING GATE WILL BE OPERATED BY A MOTOR IN ADDITION TO THE MANUAL OPERATION AT THE SITE AND REMOTE AT NEAR THE SITE.
 - b) THE GATE OPENING AND/OR CLOSING THROUGH THE MOTOR WILL BE CARRIED OUT RELATED TO THE EXISTING MANUAL HOIST AND NEW EQUIPMENT AS SHOWN ON THE DRAWN (Motorization: New equipment and existing manual Hoist).
 - c) THE GATE OPENING AND/OR CLOSING WILL BE CARRIED OUT AT THE SITE AND REMOTE OPERATION.
 - d) THE REMOTE OPERATION WILL BE CARRIED OUT AT A REMOTE OPERATION BOARD INSTALLED IN THE BUILDING (3.0 m x 4.0 m) AT NEAR THE SITE.
- (4) IN THE REMOTE OPERATION BUILDING, WHICH PROVIDED A GATE OPERATION CONSOLE OR BOARD, POWER RECEIVING PANEL, TELEMETER UNIT TO MOVING FROM OUT SIDE TO IN SIDE OF BUILDING
- (5) THE CABLE WORK IS REQUIRED BETWEEN THE SITE OF GATE OPERATION LOCATION AND REMOTE OPERATION BUILDING
- (6) THE WATER LEVEL METERS AND GATE OPERATION METERS WILL SENT TO TANTA OFFICE THROUGH VHF FOR MONITORING.

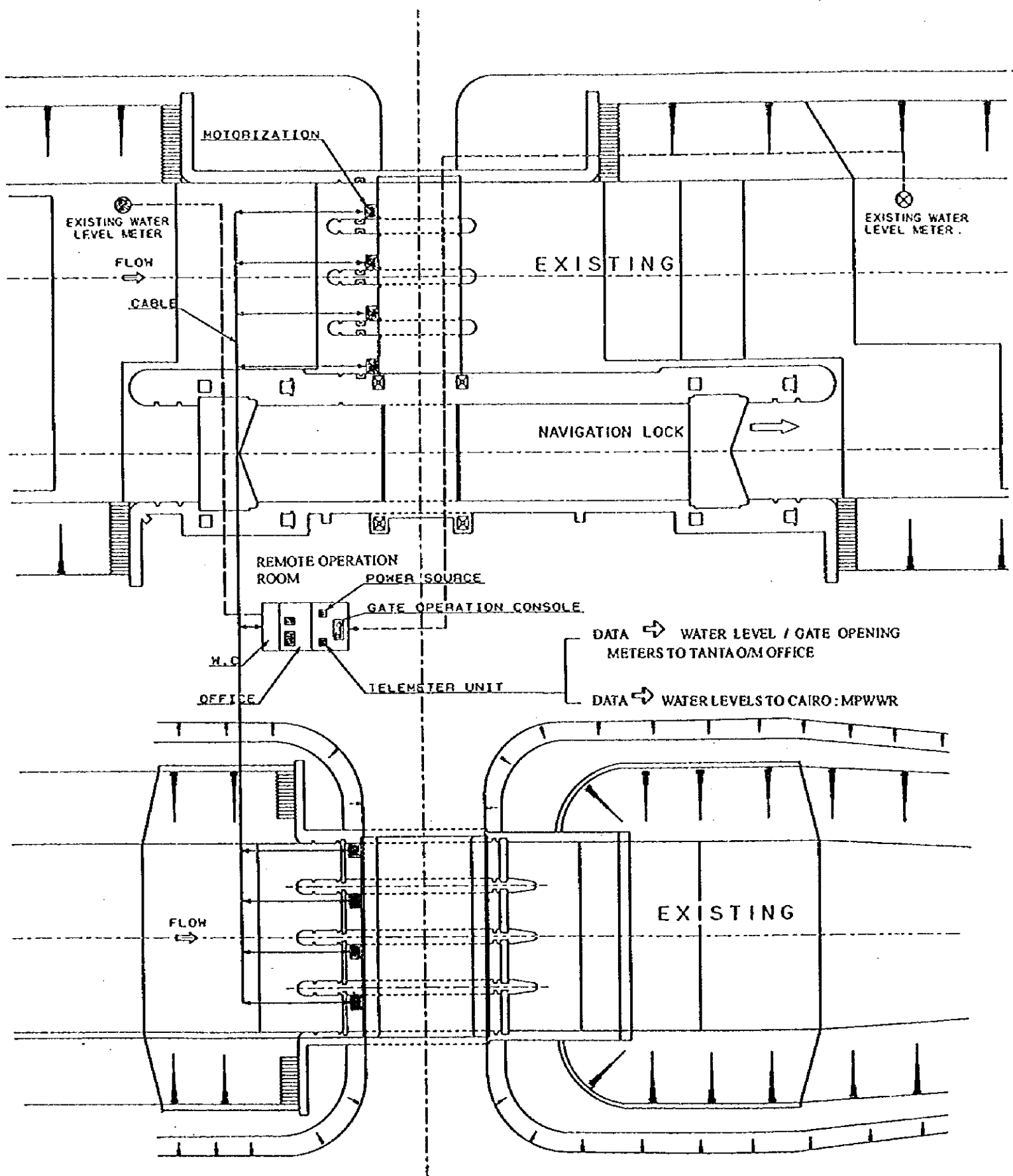
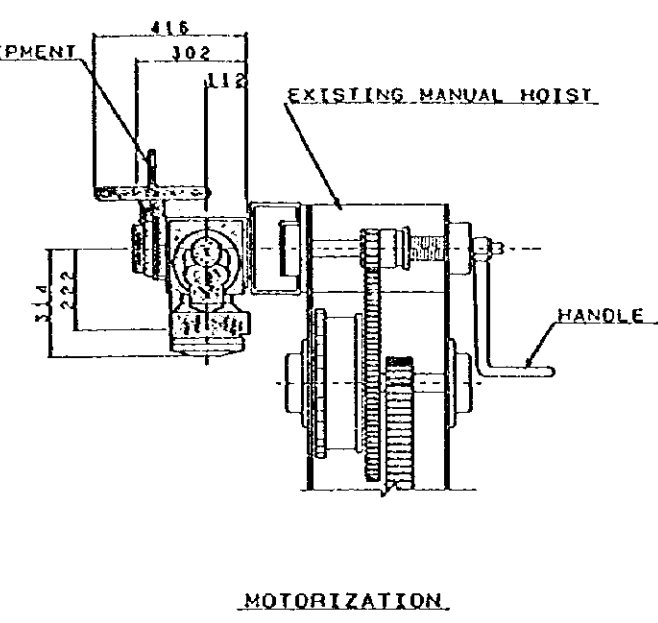

PLAN OF TERA INTAKE GATES.

JAPAN INTERNATIONAL COOPERATION AGENCY (JICA)
 MINISTRY OF PUBLIC WORKS AND
 WATER RESOURCES (MPWWR)

THE MASTER PLAN STUDY FOR THE IMPROVEMENT OF IRRIGATION
 WATER MANAGEMENT AND ENVIRONMENT CONSERVATION IN
 NORTH-EAST REGION OF THE CENTRAL NILE DELTA

IMPROVEMENT PLAN OF MOTORIZATION FOR TERA
 INTAKE GATES IN THE BAHR TERA MAIN CANAL

DATE	MARCH, 1999	FIGURE NO.	FS -04
------	-------------	------------	--------

SANYU CONSULTANTS INC., JAPAN

NOTES :

- (1) THIS DRAWING IS SHOWN THE ABSHAN REGULATOR GATE MOTORIZATION IN THE TERAMAIN CANAL.
- (2) THE LOCATION OF REGULATOR IS INDICATED ON THE FIGURE (NOMS - 1)
- (3) MAJOR DIMENSIONS, EXISTING GATE MOTORIZATION, GATE OPERATION AND MISCELLANEOUS :
 - a) THE EXISTING GATE WILL BE OPERATED BY A MOTOR IN ADDITION TO THE MANUAL OPERATION AT THE SITE AND REMOTE AT NEAR THE SITE.
 - b) THE GATE OPENING AND/OR CLOSING THROUGH THE MOTOR WILL BE CARRIED OUT RELATED TO THE EXISTING MANUAL HOIST AND NEW EQUIPMENT AS SHOWN ON THE DRAWN (Motorization: New equipment and existing manual Hoist).
 - c) THE GATE OPENING AND / OR CLOSING WILL BE CARRIED OUT AT THE SITE AND REMOTE OPERATION .
 - d) THE REMOTE OPERATION WILL BE CARRIED OUT AT A REMOTE OPERATION BOARD INSTALLED IN THE BUILDING (3.0 m x 4.0 m) AT NEAR THE SITE.
- (4) IN THE REMOTE OPERATION BUILDING, WHICH PROVIDED A GATE OPERATION CONSOLE OR BOARD, POWER RECEIVING PANEL, TELEMETER UNIT TO MOVING FROM OUT SIDE TO IN SIDE OF BUILDING
- (5) THE CABLE WORK IS REQUIRED BETWEEN THE SITE OF GATE OPERATION LOCATION AND REMOTE OPERATION BUILDING
- (6) THE WATER LEVEL METERS AND GATE OPERATION METERS WILL SENT TO KAHR EL SHEIKH OFFICE THROUGH VHF FOR MONITORING.

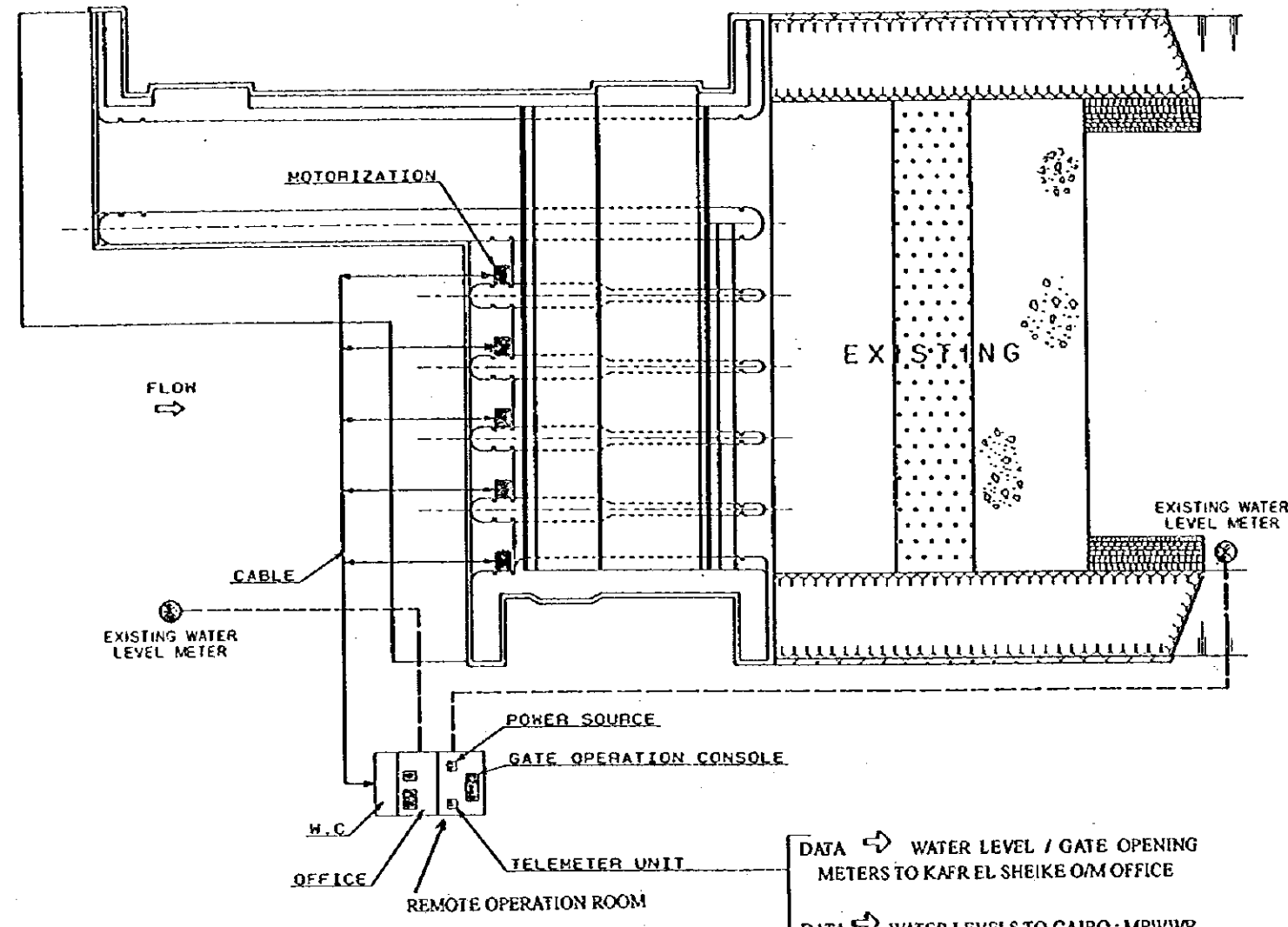

PLAN OF ABSHAN REGULATOR'S GATE OPERATION

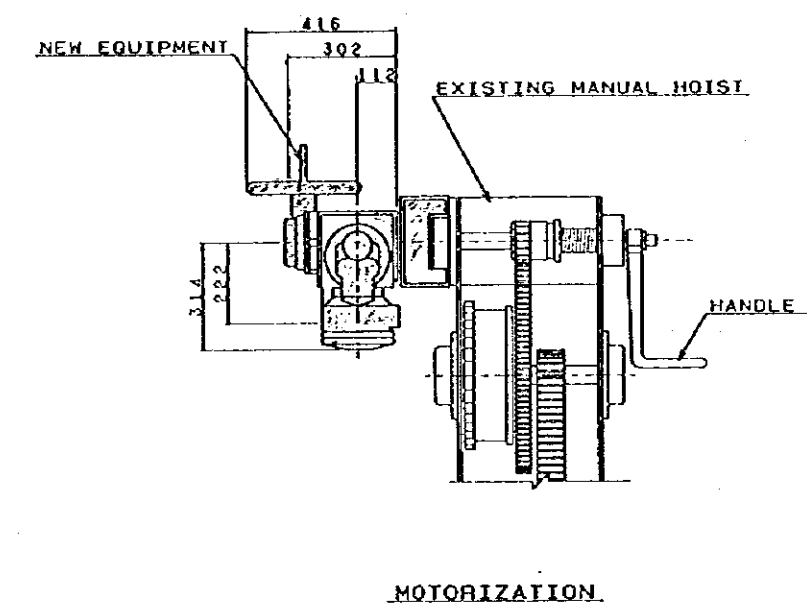

JAPAN INTERNATIONAL COOPERATION AGENCY (JICA)
 MINISTRY OF PUBLIC WORKS AND
 WATER RESOURCES (MPWWR)

THE MASTER PLAN STUDY FOR THE IMPROVEMENT OF IRRIGATION
 WATER MANAGEMENT AND ENVIRONMENT CONSERVATION IN
 NORTH-EAST REGION OF THE CENTRAL NILE DELTA

IMPROVEMENT PLAN OF MOTORIZATION FOR EPSHAN
 REGULATOR'S GATES IN THE TERAMAIN CANAL

DATE	MARCH, 1999	FIGURE NO.	FS-05
------	-------------	------------	-------

SANYU CONSULTANTS INC., JAPAN

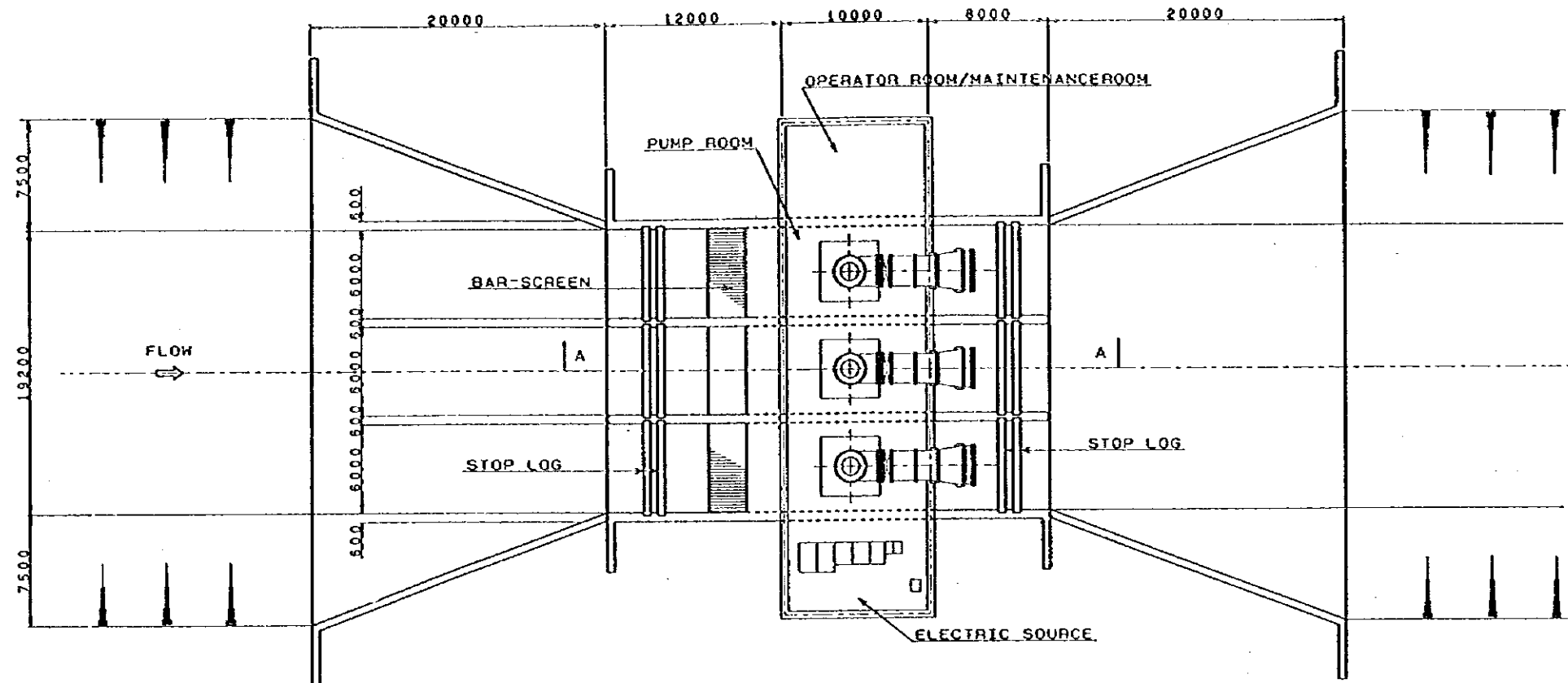

PLAN OF HAMOUL PUMP STATION

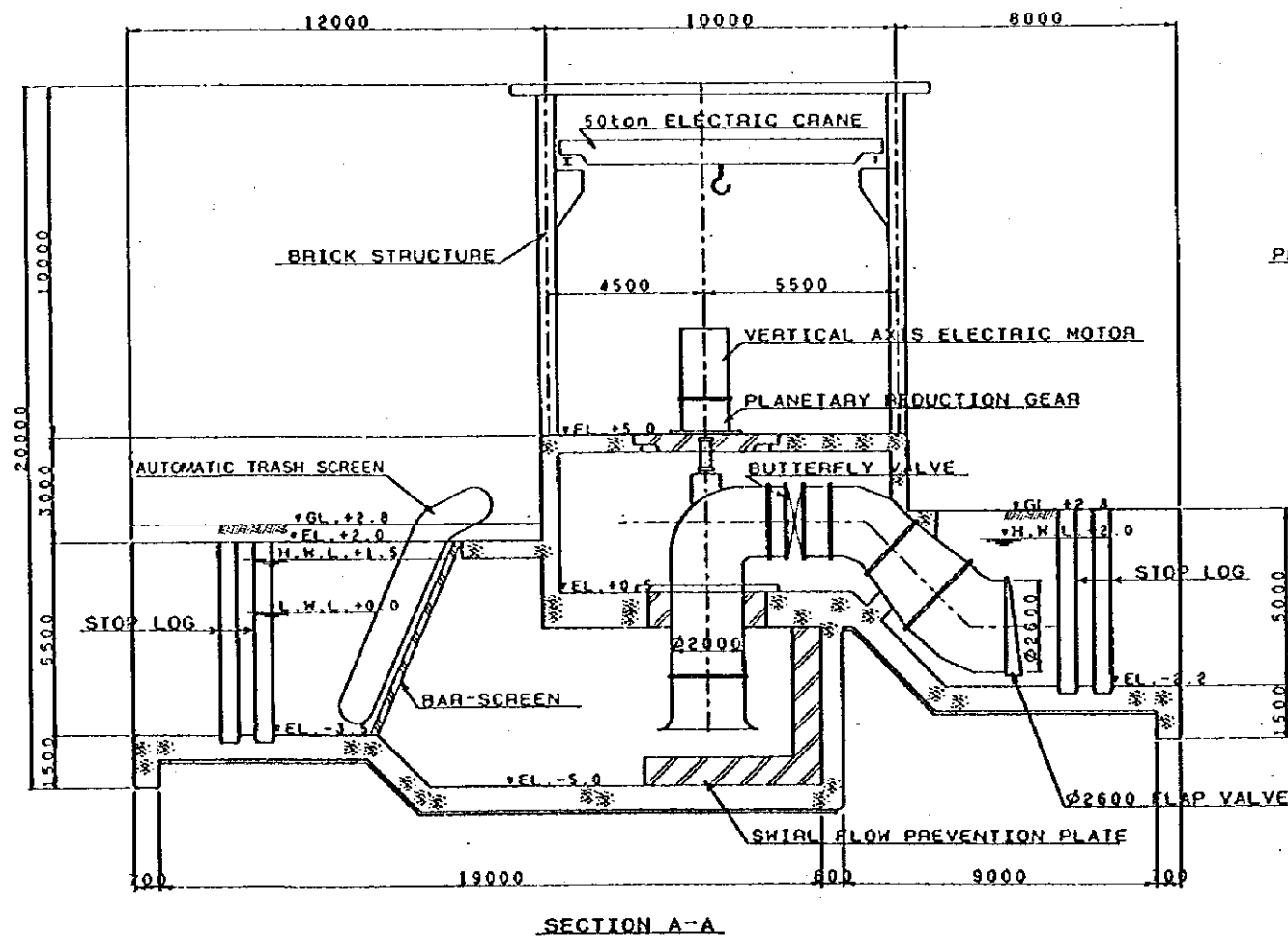

SECTION A-A

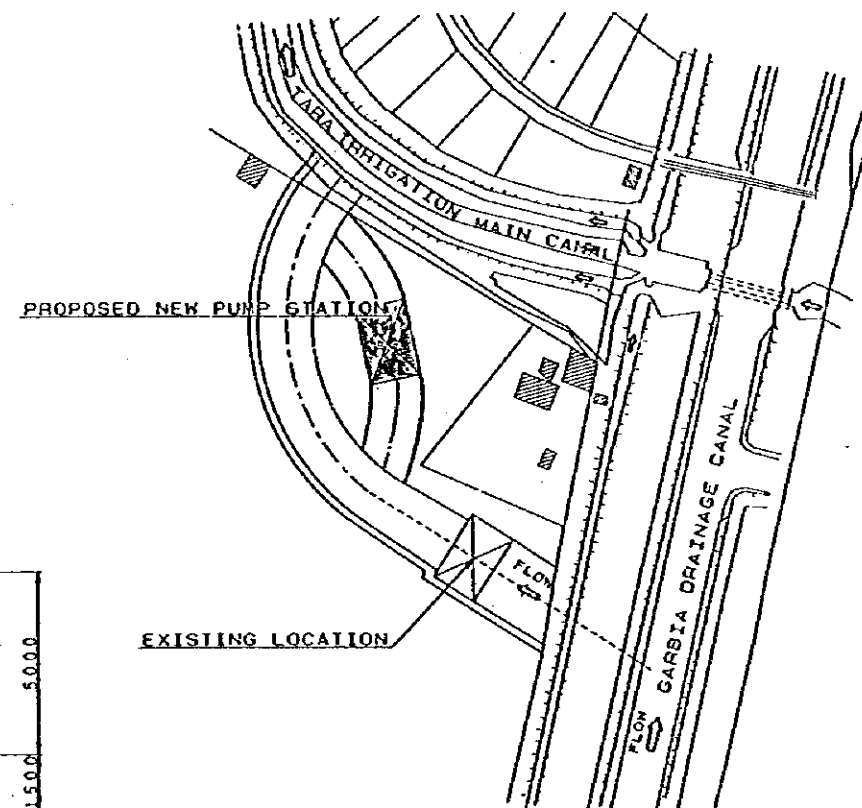

LOCATION MAP

NOTES :

- (1) THIS DRAWING IS SHOWN IMPROVEMENT OF THE HAMOUL PUMP STATION.
- (2) THE LOCATION OF PUMP STATION IS INDICATED ON THE FIGURE (NO MS - 1).
- (3) MAJOR DIMENSIONS, PUMP OPERATION PURPOSE AND MISCELLANEOUS:
 - a) PURPOSE : GARBA DRAINAGE WATER LIFTING FOR REUSE TO IRRIGATION IN TERRA DOWN STREAM AREA.
 - b) PUMP NO : 3 SETS / 30 CUM / SEC (10 cum / Sec / unit)
 - c) PUMP TYPE : VERTICAL AXIAL FLOW PUMP (1000 mm BORE)
 - d) CONSUMPTIVE USE OF POWER : 410 KW / hr / unit
 - e) SUCTION WATER LEVEL (Low) : + L.W.L. : 0.00 m
 - f) DELIVERY WATER LEVEL (High) : + H.W.L. : 2.00 m
- (4) ALL DIMENSIONS ARE SHOWN IN MILLIMETER AND ELEVATIONS (EL) IN METERS.
- (5) PROPOSED LOCATION OF NEW PUMP STATION IS LOCATED AT MED PROPERTY LAND

JAPAN INTERNATIONAL COOPERATION AGENCY (JICA)
 MINISTRY OF PUBLIC WORKS AND
 WATER RESOURCES (MPWWR)

THE MASTER PLAN STUDY FOR THE IMPROVEMENT OF IRRIGATION
 WATER MANAGEMENT AND ENVIRONMENT CONSERVATION IN
 NORTH-EAST REGION OF THE CENTRAL NILE DELTA

IMPROVEMENT PLAN OF HAMOUL
 PUMP STATION

DATE	MARCH, 1999	FIGURE NO.	FS-06
------	-------------	------------	-------

SANYU CONSULTANTS INC., JAPAN

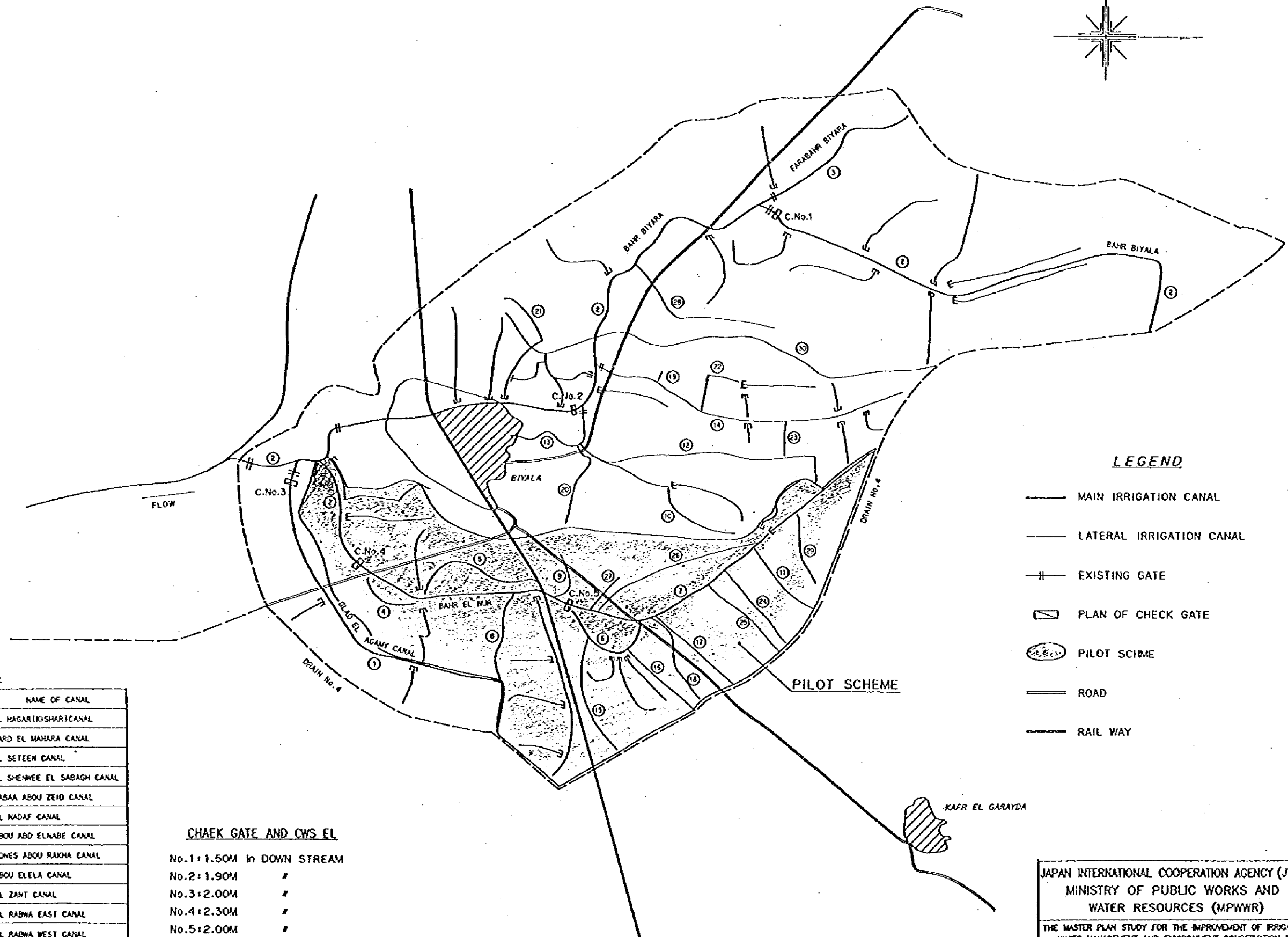
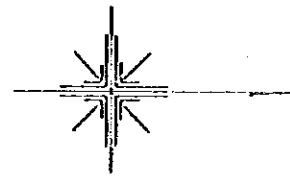

LEGEND

- MAIN IRRIGATION CANAL
- LATERAL IRRIGATION CANAL
- EXISTING GATE
- ▭ PLAN OF CHECK GATE
- ⊙ PILOT SCHEME
- ROAD
- RAIL WAY

NAME OF CANALS

No.	NAME OF CANAL	No.	NAME OF CANAL
1	GARD EL AGAMY CANAL	16	EL HAGAR (KISHAR) CANAL
2	BAHR BIYALA CANAL	17	GARD EL MAHARA CANAL
3	FARA BIYALA CANAL	18	EL SETEEN CANAL
4	BAHR ELMUR (1) CANAL	19	EL SHENWEE EL SABAGH CANAL
5	BAHR ELMUR (2) CANAL	20	PABAA ABOU ZEHD CANAL
6	BAHR ELMUR (3) CANAL	21	EL NADAF CANAL
7	BAHR ELMUR CANAL	22	ABOU ABO ELNABE CANAL
8	ABO KORA CANAL	23	UONES ABOU RAJMA CANAL
9	EL MASHABK CANAL	24	ABOU ELELA CANAL
10	ZAYKORA CANAL	25	EL ZAYT CANAL
11	BAGARA CANAL	26	EL RABWA EAST CANAL
12	EL BAHRIA - A CANAL	27	EL RABWA WEST CANAL
13	EL BAHRIA - B CANAL	28	HAMAMO CANAL
14	EL SHURFA CANAL	29	BAHR EL MUR EXTENSION CANAL
15	EL WALDA CANAL	30	BAB EL FASHOOL CANAL

CHEAK GATE AND CWS EL

- No.1: 1.50M In DOWN STREAM
- No.2: 1.90M "
- No.3: 2.00M "
- No.4: 2.30M "
- No.5: 2.00M "

JAPAN INTERNATIONAL COOPERATION AGENCY (JICA)
 MINISTRY OF PUBLIC WORKS AND
 WATER RESOURCES (MPWWR)

THE MASTER PLAN STUDY FOR THE IMPROVEMENT OF IRRIGATION
 WATER MANAGEMENT AND ENVIRONMENT CONSERVATION IN
 NORTH-EAST REGION OF THE CENTRAL NILE DELTA

PROSED LOCATION OF PILOT SCHEME

DATE	MARCH, 1999	FIGURE NO.	FS-07
------	-------------	------------	-------

SANYU CONSULTANTS INC., JAPAN

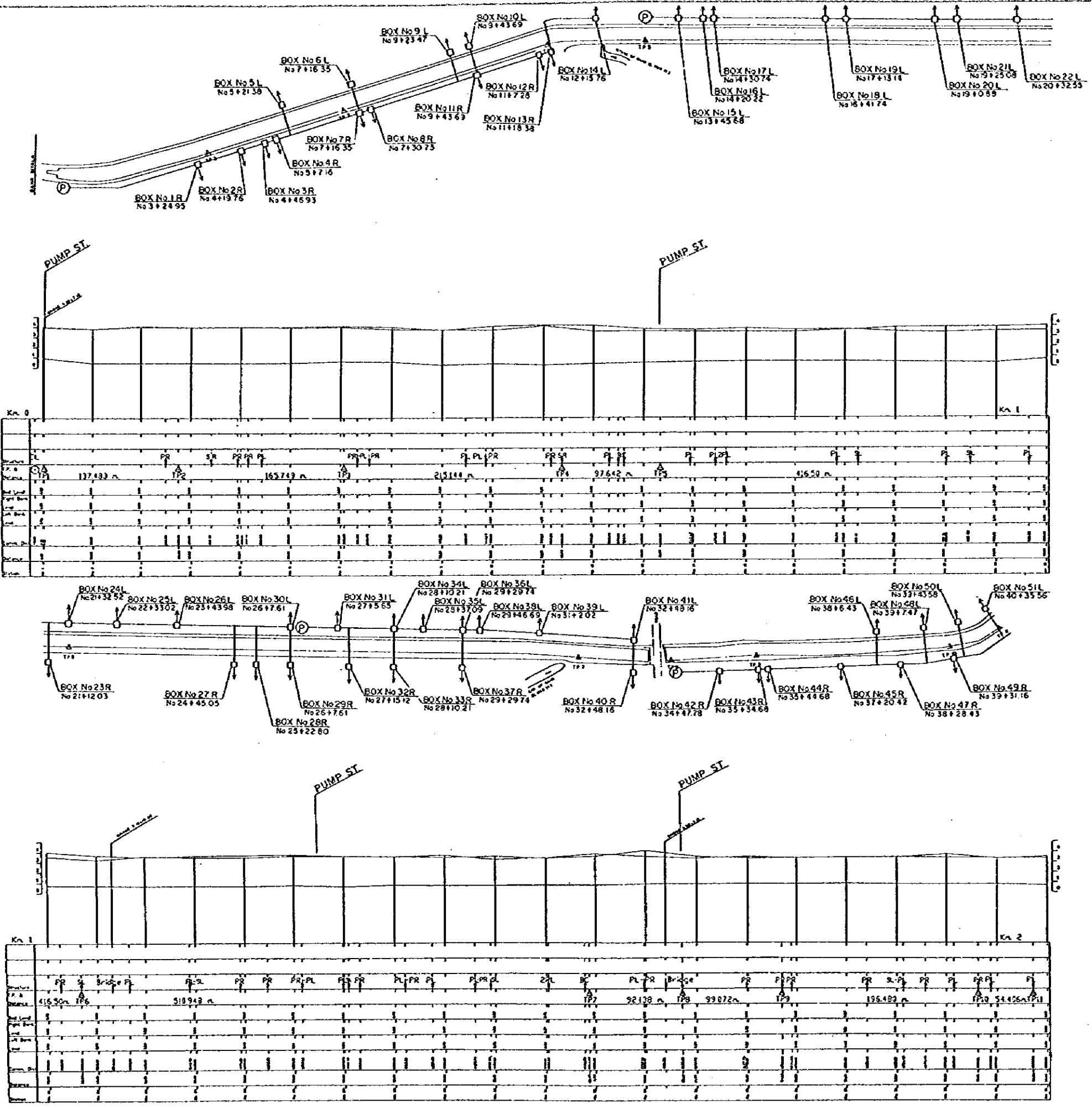

- NOTES:
- (1) THIS DRAWING IS SHOWN AN IMPROVEMENT OF MESKA WATER SUPPLY SYSTEM IN PLACE OF THE EXISTING FARMER'S PUMP TO MARUWA DIRECTLY FROM NUR CANAL (DELIVERY CANAL)
 - (2) THE LOCATION OF NUR CANAL IS SHOWN ON THE FIGURE NO MS-1 AND FS-07.
 - (3) THE PLAN AND PROFILE DRAWINGS ALONG THE NUR CANAL CONSIST OF FIGURE NO (FS-08,09,10 AND 11)
 - (4) THE FOLLOWING DRAWINGS ARE RELATED TO THIS DRAWING:
 - a) TYPICAL DRAWING FOR ONE POINT LIFTING MESKA (FIG. NO DD-21)
 - b) TYPICAL DRAWING FOR OPEN MESKA (FIG. NO DD-22)
 - c) TYPICAL DRAWING FOR PIPE MESKA (FIG. NO DD-23)
 - d) TYPICAL DRAWING FOR PUMP HOUSE (FIG. NO DD-24)
 - e) MISCELLANEOUS (FIG. NO DD-25)

REFERENCE	
△	TRAVERSE POINT
RL	RED LEVEL
S.L.	LEFT BANK LEVEL
R.L.	RIGHT BANK LEVEL
SL	LEFT SAKTA
SR	RIGHT SAKTA
PL	LEFT PUMP
PR	RIGHT PUMP
B	BRIDGE
BC	BRANCH CANAL
CB	CROSS DRAIN

JAPAN INTERNATIONAL COOPERATION AGENCY (JICA)
 MINISTRY OF PUBLIC WORKS AND
 WATER RESOURCES (MPWWR)

THE MASTER PLAN STUDY FOR THE IMPROVEMENT OF IRRIGATION
 WATER MANAGEMENT AND ENVIRONMENT CONSERVATION IN
 NORTH-EAST REGION OF THE CENTRAL NILE DELTA

IMPROVEMENT OF EL NUR CANAL
 PLAN AND PROFILE (1/4)

DATE MARCH, 1999 FIGURE NO. FS-08
 SANYU CONSULTANTS INC., JAPAN

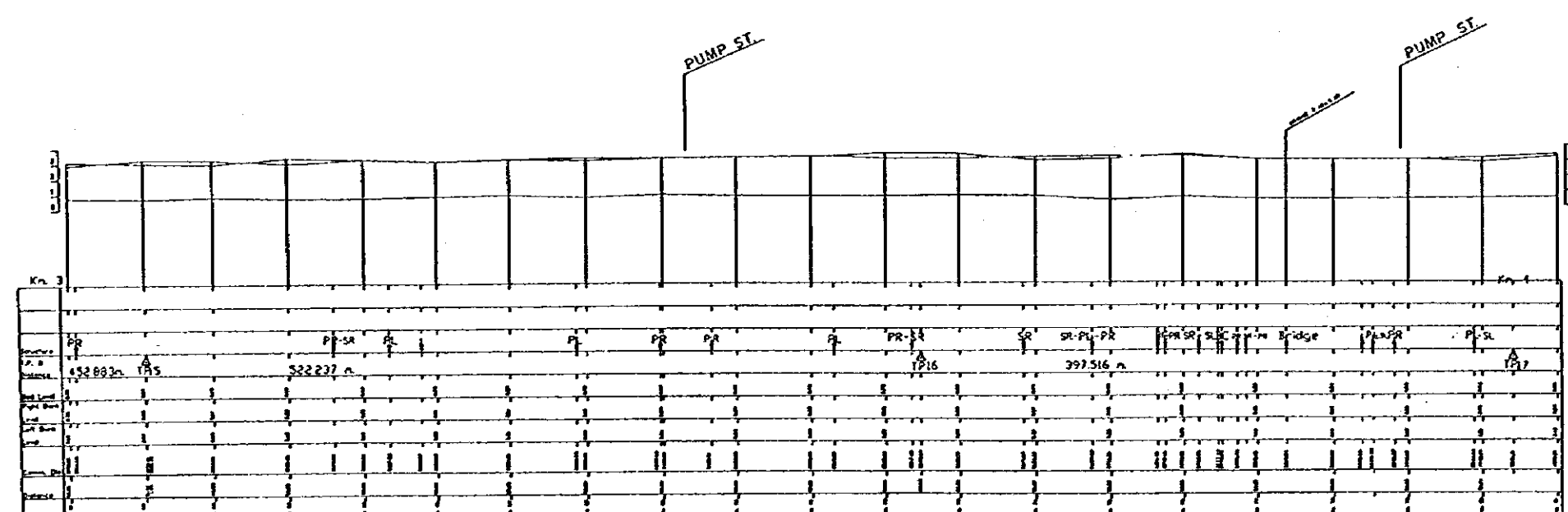
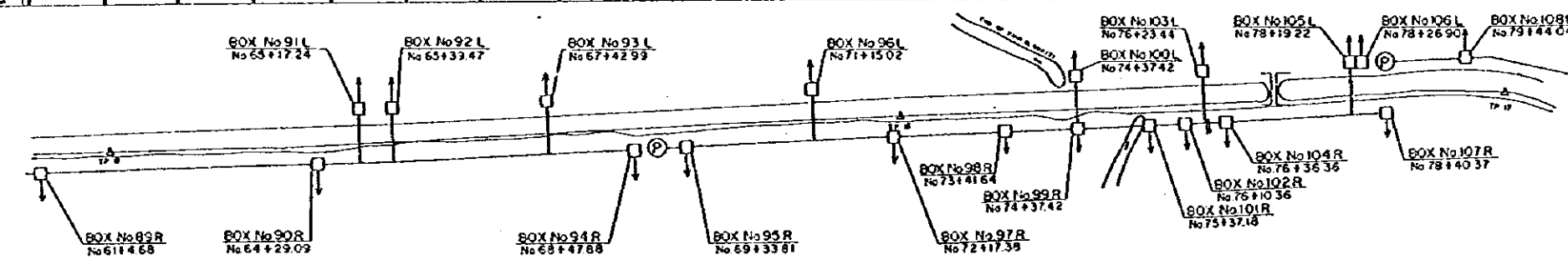
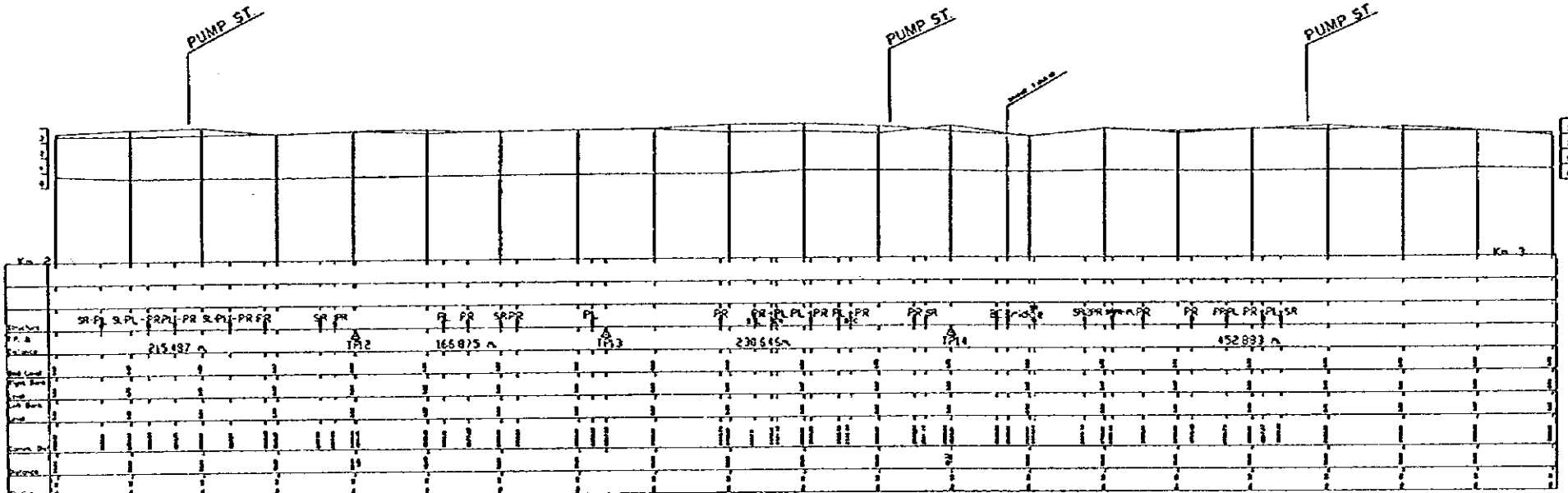
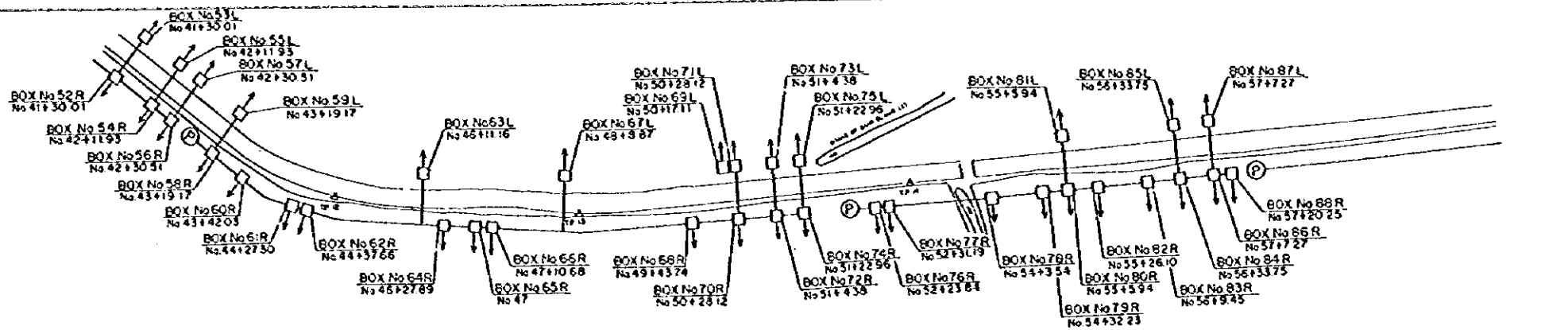

- NOTES :
- (1) THIS DRAWING IS SHOWN AN IMPROVEMENT OF MESKA WATER SUPPLY SYSTEM IN PLACE OF THE EXISTING FARMER'S PUMP TO MARUWA DIRECTLY FROM NUR CANAL (DELIVERY CANAL.)
 - (2) THE LOCATION OF NUR CANAL IS SHOWN ON THE FIGURE NO MS-1 AND FS-07.
 - (3) THE PLAN AND PROFILE DRAWINGS ALONG THE NUR CANAL CONSIST OF FIGURE NO (FS-08,09,10 AND 11).
 - (4) THE FOLLOWING DRAWINGS ARE RELATED TO THIS DRAWING:
 - a) TYPICAL DRAWING FOR ONE POINT LIFTING MESKA (FIG. NO DD-21)
 - b) TYPICAL DRAWING FOR OPEN MESKA (FIG. NO DD-22)
 - c) TYPICAL DRAWING FOR PIPE MESKA (FIG. NO DD-23)
 - d) TYPICAL DRAWING FOR PUMP HOUSE (FIG. NO DD-24)
 - e) MISCELLANEOUS (FIG. NO DD-25)

REFERENCE	
△	TRAVERSE POINT
△	REF LEVEL
LB	LEFT BANK LEVEL
RB	RIGHT BANK LEVEL
SL	LEFT SAKTA
SR	RIGHT SAKTA
PL	LEFT PUMP
PR	RIGHT PUMP
B	BRIDGE
BC	BRANCH CANAL
CB	CROSS BRAIN

JAPAN INTERNATIONAL COOPERATION AGENCY (JICA)
 MINISTRY OF PUBLIC WORKS AND
 WATER RESOURCES (MPWWR)

THE MASTER PLAN STUDY FOR THE IMPROVEMENT OF IRRIGATION
 WATER MANAGEMENT AND ENVIRONMENT CONSERVATION IN
 NORTH-EAST REGION OF THE CENTRAL NILE DELTA

IMPROVEMENT OF EC NUR CANAL
 PLAN AND PROFILE (2/4)

DATE MARCH, 1999 FIGURE NO. FS-09
 SANYU CONSULTANTS INC., JAPAN

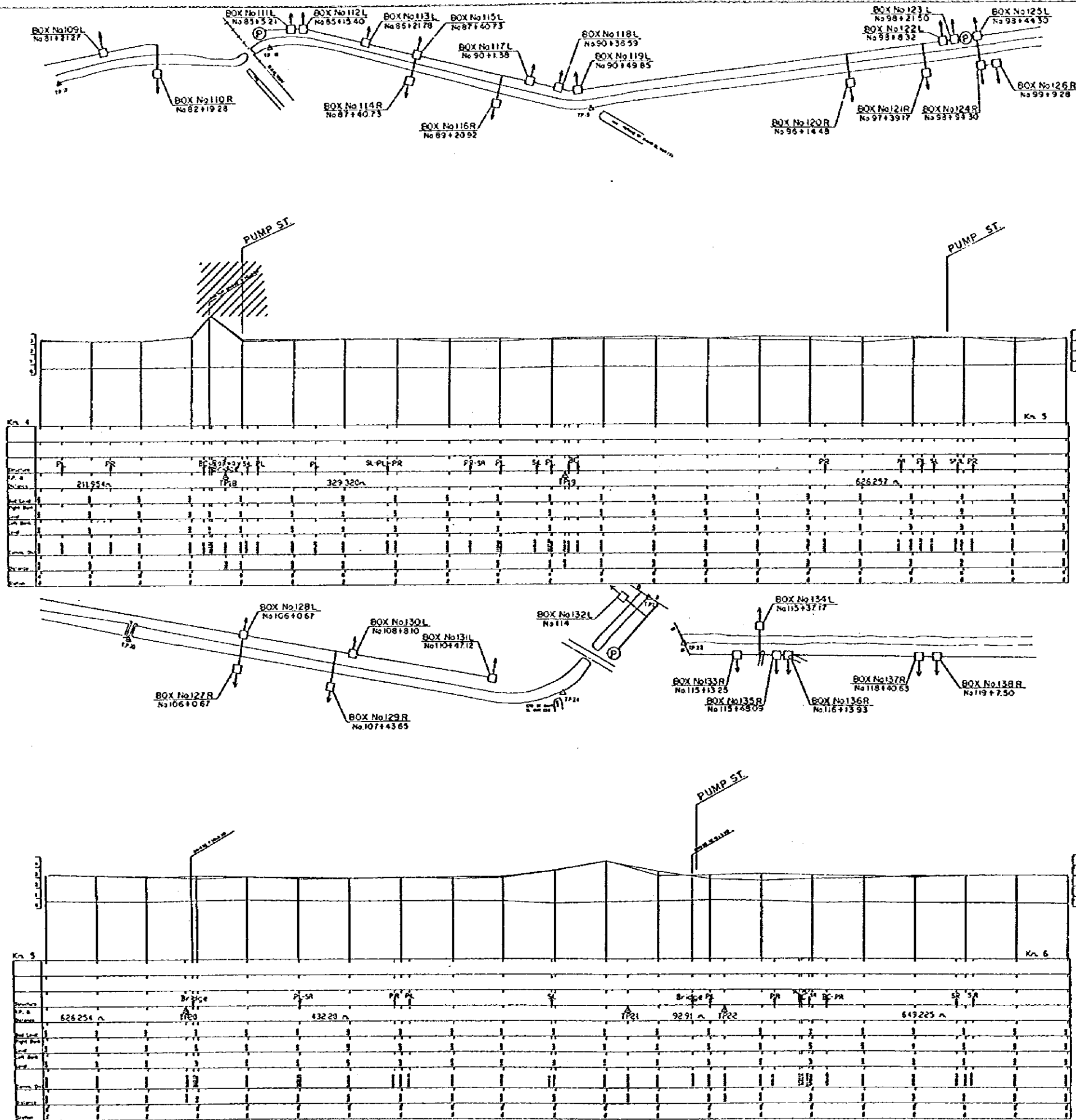

NOTES:

- (1) THIS DRAWING IS SHOWN AN IMPROVEMENT OF MESKA WATER SUPPLY SYSTEM IN PLACE OF THE EXISTING FARMER'S PUMP TO MARUWA DIRECTLY FROM NUR CANAL (DELIVERY CANAL)
- (2) THE LOCATION OF NUR CANAL IS SHOWN ON THE FIGURE NO MS-1 AND FS-07.
- (3) THE PLAN AND PROFILE DRAWINGS ALONG THE NUR CANAL CONSIST OF FIGURE NO (FS-08,09,10 AND 11).
- (4) THE FOLLOWING DRAWINGS ARE RELATED TO THIS DRAWING:

- a) TYPICAL DRAWING FOR ONE POINT LIFT FROM MESKA (FIG. NO DD-21)
- b) TYPICAL DRAWING FOR OPEN MESKA (FIG. NO DD-22)
- c) TYPICAL DRAWING FOR PIPE MESKA (FIG. NO DD-23)
- d) TYPICAL DRAWING FOR PUMP HOUSE (FIG. NO DD-24)
- e) MISCELLANEOUS (FIG. NO DD-25)

REFERENCE	
△	TRAVERSE POINT
R	BED LEVEL
LR	LEFT BANK LEVEL
RR	RIGHT BANK LEVEL
SL	LEFT SACTA
SR	RIGHT SACTA
PL	LEFT PUMP
PR	RIGHT PUMP
B	BRIDGE
BC	BRANCH CANAL
CB	CROSS DRAIN

JAPAN INTERNATIONAL COOPERATION AGENCY (JICA)
 MINISTRY OF PUBLIC WORKS AND
 WATER RESOURCES (MPWWR)

THE MASTER PLAN STUDY FOR THE IMPROVEMENT OF IRRIGATION
 WATER MANAGEMENT AND ENVIRONMENT CONSERVATION IN
 NORTH-EAST REGION OF THE CENTRAL NILE DELTA

IMPROVEMENT OF EL NUR CANAL
 PLAN AND PROFILE (3/4)

DATE MARCH, 1999 FIGURE NO. FS-10

SANYU CONSULTANTS INC., JAPAN

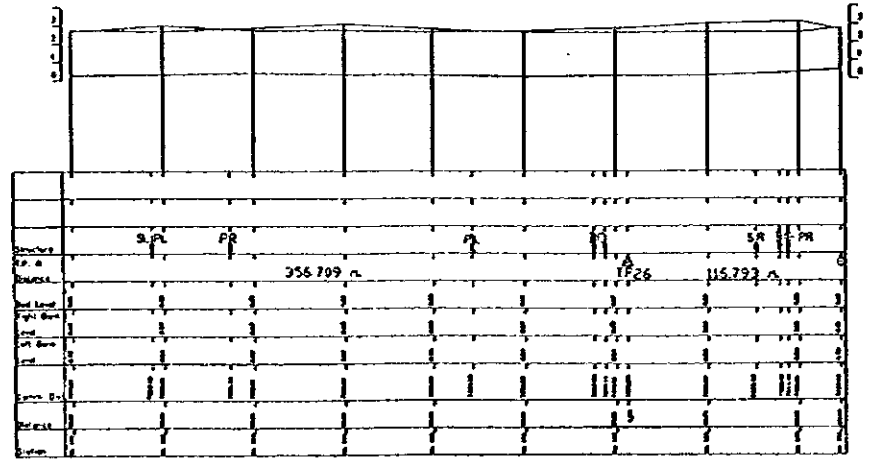
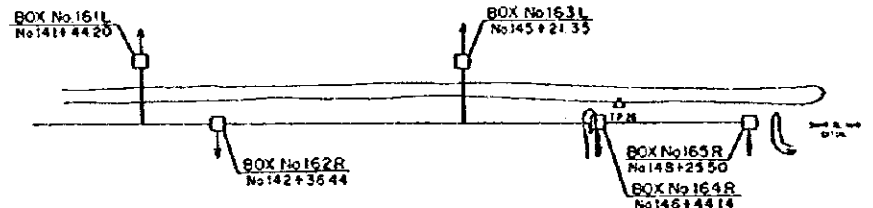
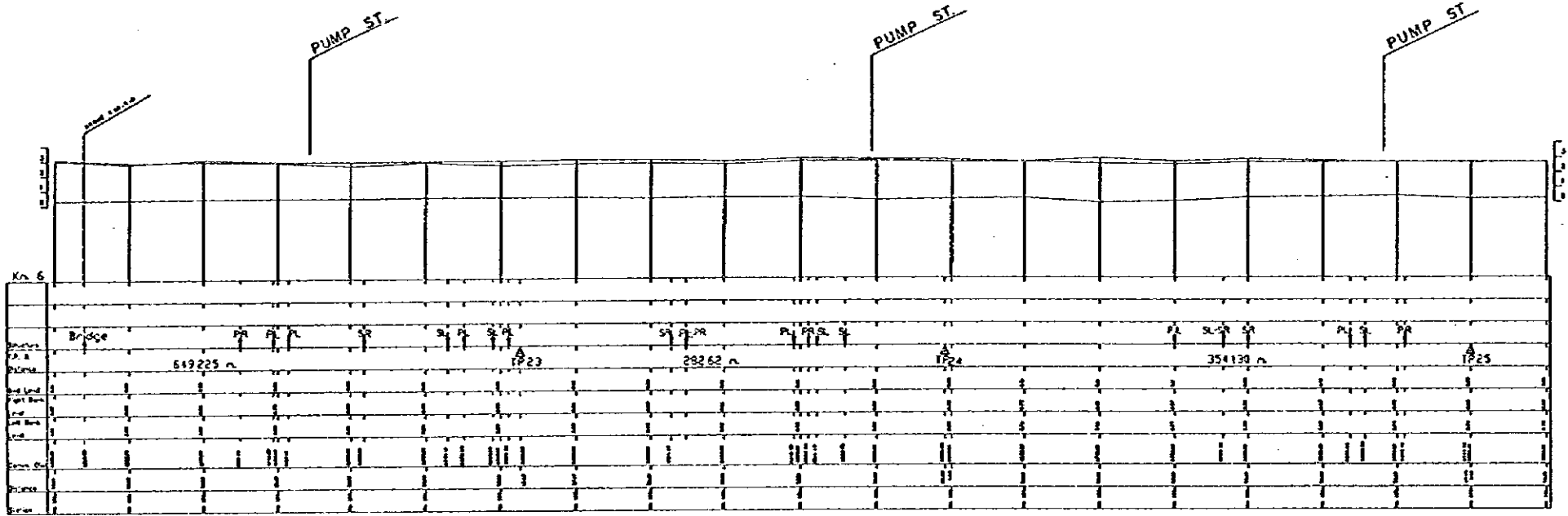
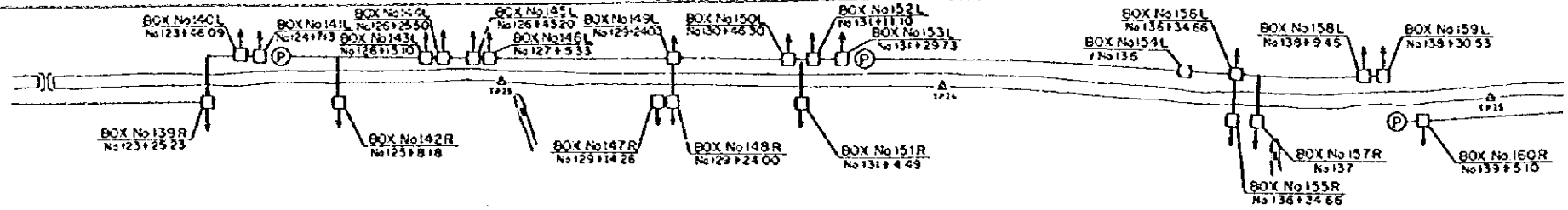

- NOTES :
- (1) THIS DRAWING IS SHOWN AN IMPROVEMENT OF MESKA WATER SUPPLY SYSTEM IN PLACE OF THE EXISTING FARMER'S PUMP TO MARUWA, DIRECTLY FROM NUR CANAL (DELIVERY CANAL)
 - (2) THE LOCATION OF NUR CANAL IS SHOWN ON THE FIGURE NO MS-1 AND FS-07.
 - (3) THE PLAN AND PROFILE DRAWINGS ALONG THE NUR CANAL CONSIST OF FIGURE NO (FS-08,09,10 AND 11)
 - (4) THE FOLLOWING DRAWINGS ARE RELATED TO THIS DRAWING:
 - a) TYPICAL DRAWING FOR ONE POINT LIFTING MESKA (FIG. NO DD-21)
 - b) TYPICAL DRAWING FOR OPEN MESKA (FIG. NO DD-22)
 - c) TYPICAL DRAWING FOR PIPE MESKA (FIG. NO DD-23)
 - d) TYPICAL DRAWING FOR PUMP HOUSE (FIG. NO DD-24)
 - e) MISCELLANEOUS (FIG. NO DD-25)

REFERENCE	
△	TRAVERSE POINT
R	BED LEVEL
L.B.	LEFT BANK LEVEL
R.B.	RIGHT BANK LEVEL
SL	LEFT SACTA
SR	RIGHT SACTA
PL	LEFT PUMP
PR	RIGHT PUMP
B	BRIDGE
BC	BRANCH CANAL
CD	CROSS DRAIN

JAPAN INTERNATIONAL COOPERATION AGENCY (JICA)
 MINISTRY OF PUBLIC WORKS AND
 WATER RESOURCES (MPWWR)

THE MASTER PLAN STUDY FOR THE IMPROVEMENT OF IRRIGATION
 WATER MANAGEMENT AND ENVIRONMENT CONSERVATION IN
 NORTH-EAST REGION OF THE CENTRAL NILE DELTA

IMPROVEMENT OF EL' NUR CANAL
 PLAN AND PROFILE (1/4)

DATE MARCH, 1999 FIGURE NO. FS-11
 SANYU CONSULTANTS INC., JAPAN

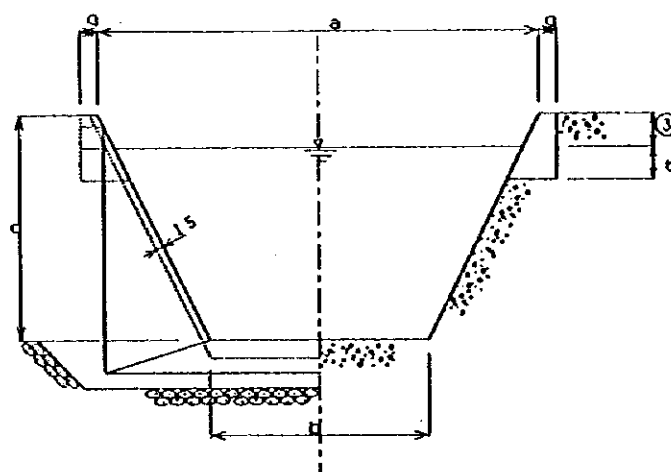
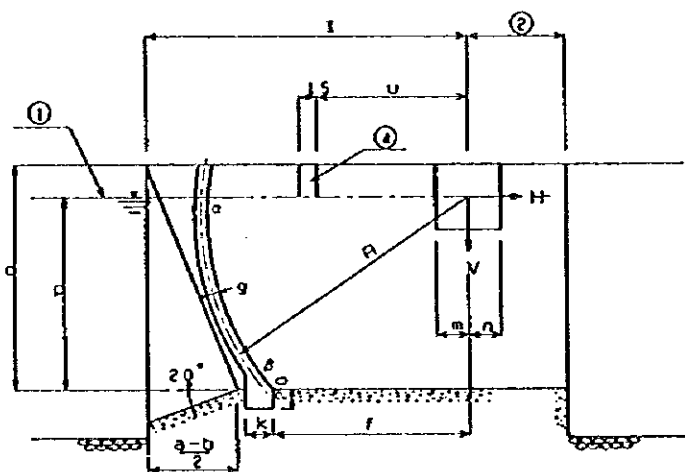
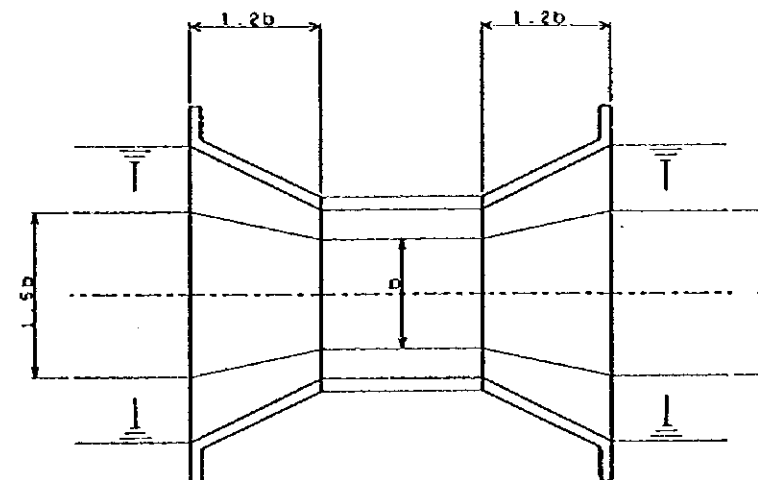
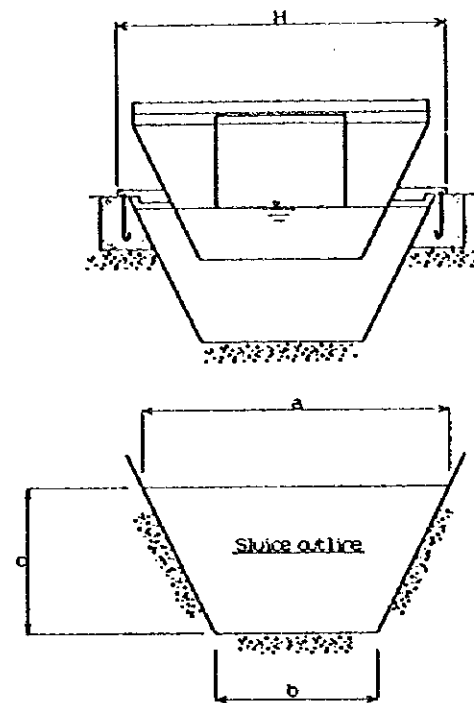
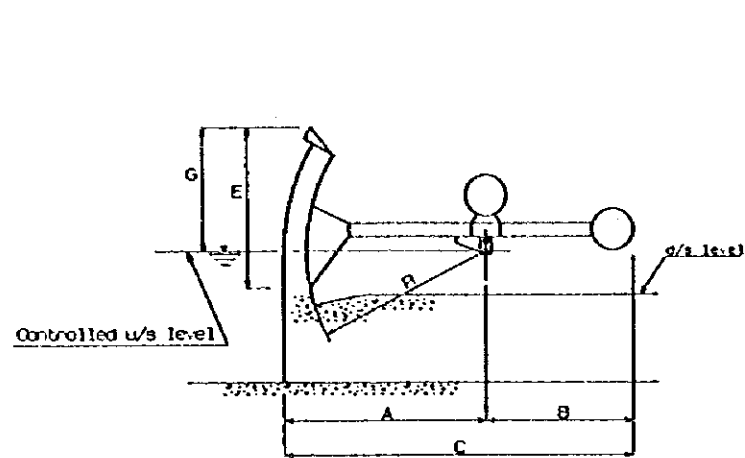

Dimensions in cm

AMIL		OVERALL DIMENSIONS (Gate open)							SLUICE OUTLINE DIM.		
D	R	A	B	C	E	G	H	a	b	c	
140	90	104	71	175	81	50	171	150	80	71	
160	90	106	71	177	95	60	191	170	90	80	
180	125	143	101	244	102	68	214	190	100	90	
200	125	145	101	246	117	73	236	212	112	100	
220	125	148	101	249	134	85	260	236	125	112	
250	160	185	117	301	144	91	303	265	140	125	
280	160	188	117	304	166	105	336	300	160	140	
315	200	232	145	377	181	112	390	335	180	160	
355	200	236	145	381	214	135	430	375	200	180	
400	250	290	185	475	234	145	474	425	224	200	
450	250	295	185	480	268	170	520	475	250	224	
500	315	365	236	601	289	183	540	530	280	250	
560	315	371	236	607	333	211	605	600	315	280	
630	400	463	298	761	361	233	677	670	355	315	
710	400	471	298	769	419	265	762	750	400	355	
800	450	530	333	863	481	305	871	850	450	400	

Dimensions in cm

TYPE	SLUICE			u/s depth	STRUCTURE DEFINITION															THRUSTS on STRUCTURE	
	D	R	a		b	c	p	e	f	g	k	i	m	n	q	t	u	p	H	V	
140	90	150	80	71	63	35	-	-	-	108	18	18	15	20	-	-	-	0.10	0.15		
160	90	170	90	80	71	40	-	-	-	108	18	18	15	20	-	-	-	0.15	0.20		
180	125	190	100	90	80	45	86	15	30	150	23	23	18	20	-	-	150	0.20	0.30		
200	125	212	112	100	90	50	76	15	30	150	23	23	18	20	-	-	149	0.30	0.40		
220	125	236	125	112	100	55	62	15	30	150	23	23	18	20	-	-	148	0.40	0.40		
250	160	285	140	125	112	62	108	15	30	192	25	25	25	15	-	-	190	0.80	0.50		
280	160	300	160	140	125	70	87	15	30	192	25	25	25	15	-	-	189	1.00	0.80		
315	200	335	180	160	140	77	128	20	40	240	25	25	35	17	-	-	238	1.50	1.00		
355	200	375	200	180	160	87	102	20	40	240	25	25	35	17	-	-	236	2.00	1.50		
400	250	425	224	200	180	100	159	20	40	300	33	33	35	22	-	-	298	3.00	2.00		
450	250	475	250	224	200	112	133	20	40	300	33	33	35	22	-	-	295	4.00	3.00		
500	315	530	280	250	224	125	207	20	40	378	60	60	40	20	60	200	375	5.00	4.00		
560	315	600	315	280	250	142	175	20	40	378	60	60	40	20	60	200	372	8.00	5.00		
630	400	670	355	315	280	157	272	20	40	480	70	70	50	30	80	250	476	10.00	8.00		
710	400	750	400	355	315	175	230	20	40	480	70	70	50	30	80	250	472	14.00	10.00		
800	450	850	450	400	360	200	253	20	40	540	80	80	50	40	90	275	531	20.00	18.00		

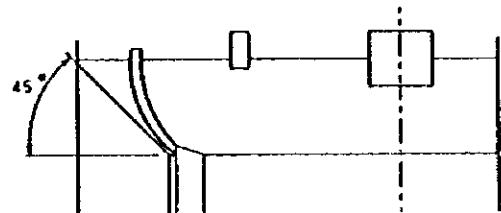

H, Horizontal thrust on the concrete, per bearing (in metric tons)
V, Vertical thrust on the concrete, per bearing (in metric tons)

- Controlled upstream level.
- To be defined according to structure stability and concrete strength.
- Freeboard depending on local conditions.
- One grouting hole on left bank, for AMIL D 500 and larger.

a/B: For determining the groove edge position in the plane of the side walls, find the centre of the circle of radius R passing through points a and B (distance between a and the axis = R - g; distance between B and the vertical line passing through the axis = R). Then trace from this centre the circles of radii R and R + g.

NOTES:

- (1) THIS DRAWING IS INDICATED ATYPICAL DIMENSIONS OF THE CHECK STRUCTURE AND RELATED TO AN OPEN TRANSITION AT FRONT AND BACK STREAMS ON THE DELIVERY CANAL.
- (2) SCOPE OF WORK FOR CHECK STRUCTURE IS LIMITED INCLUDING A PART OF CHECK STRUCTURE AND OPEN TRANSITIONS.
- (3) DETAILED PLAN AND DESIGN ARE APPLIED BASED ON THESE DIMENSIONS INDICATED IN CENTIMETER.
- (4) THE CHECK STRUCTURES WORKS WILL BE CARRIED OUT BASED ON THE FOLLOWING SPECIFICATIONS APPROVED BY THE IIS.
 - a) CIVIL WORK
THE CIVIL WORK IS APPLIED BY THE IIS SPECIFICATIONS, INCLUDING EARTH, CONCRETE AND MISCELLANEOUS.
 - b) STEEL MATERIALS
THE STEEL WORKS, INCLUDING MATERIAL ASSEMBLY TO BE AFFIXED MILL SHEET OF CERTIFICATE FOR THE MATERIALS.
 - c) MANUFACTURE
MANUFACTURE'S SPECIFICATIONS, ASSEMBLY, CUTTING, WELDING, TESTING, PAINTING AND TRANSPORTATION.
 - d) INSTALLATION WORK AND TAKE OVER
HANDING, INSTALLATION, TESTING AT THE SITE AS WELL AS PROVISIONAL / FINAL TAKE OVER AND/OR GUARANTEE PERIOD.

JAPAN INTERNATIONAL COOPERATION AGENCY (JICA)
MINISTRY OF PUBLIC WORKS AND
WATER RESOURCES (MPWWR)

THE MASTER PLAN STUDY FOR THE IMPROVEMENT OF IRRIGATION
WATER MANAGEMENT AND ENVIRONMENT CONSERVATION IN
NORTH-EAST REGION OF THE CENTRAL NILE DELTA

PLAN OF CHECK GATE
IN THE DELIVERY CANAL

DATE MARCH, 1999 FIGURE NO. FS-12

SANYU CONSULTANTS INC., JAPAN

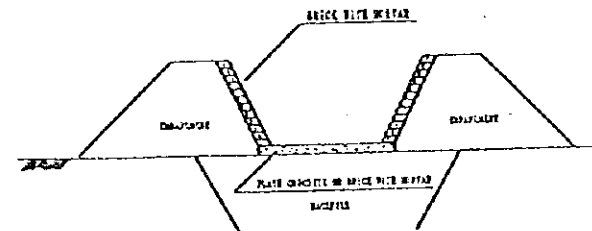
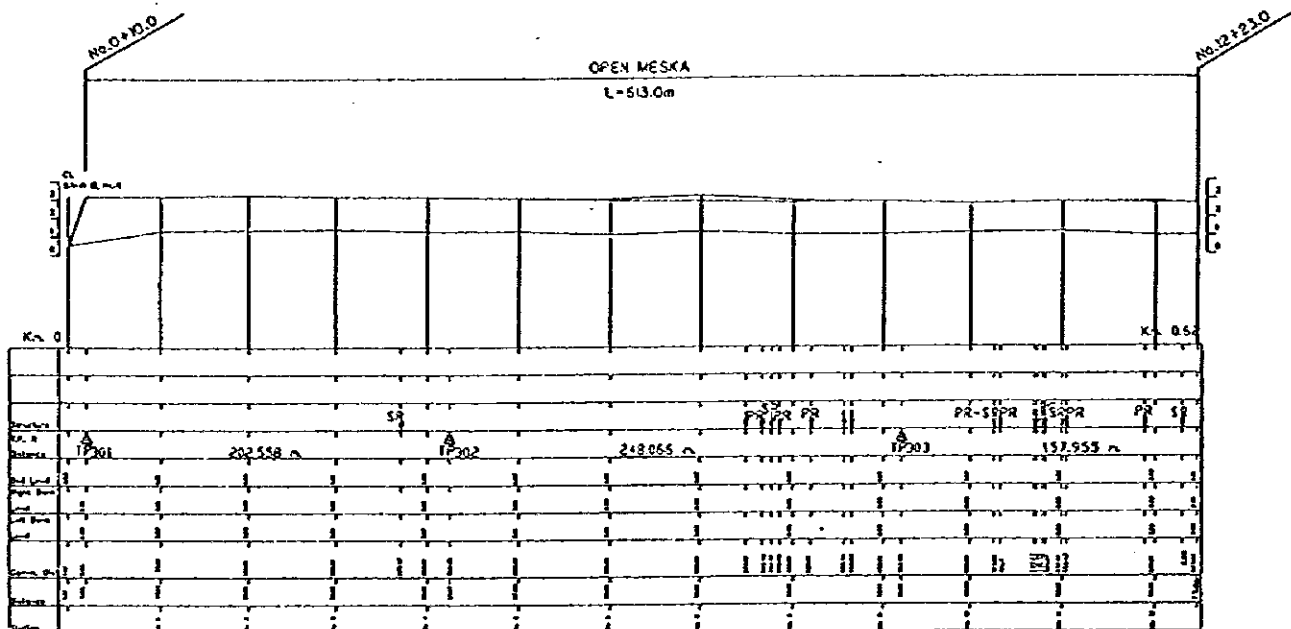
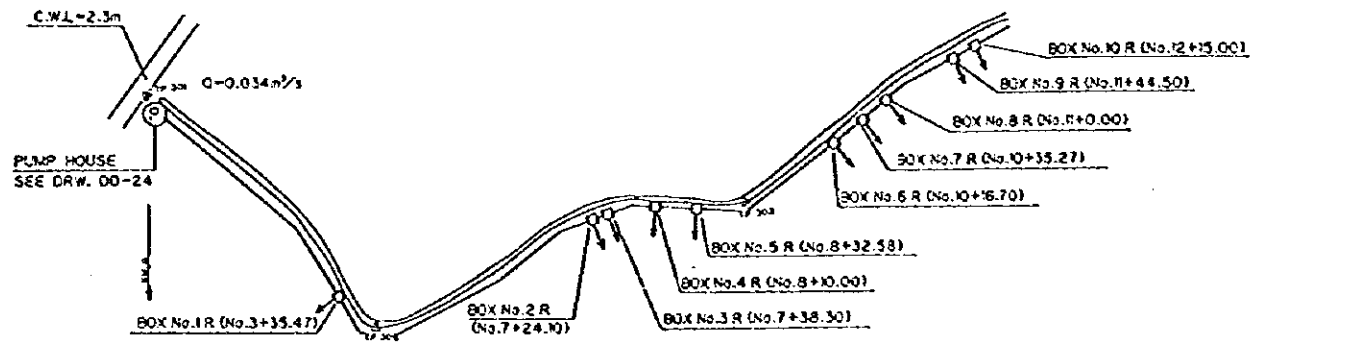

TYPICAL SECTION
OPEN MESKA
SEE DRW. DD-22

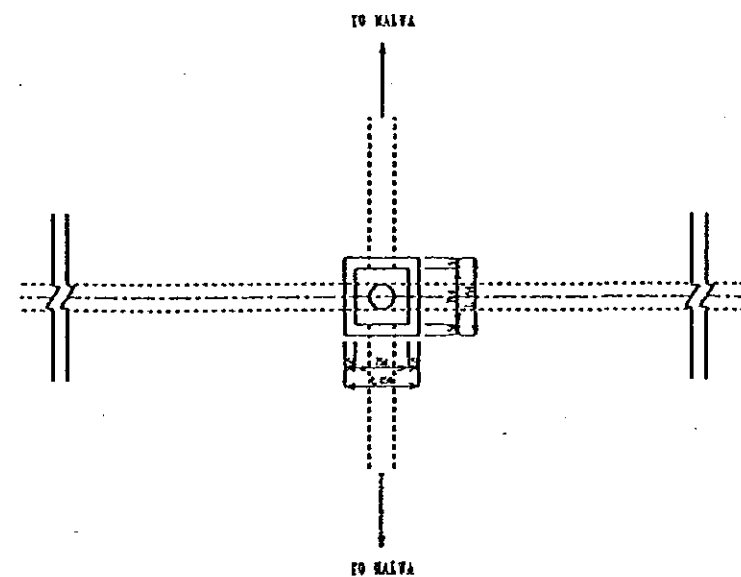

BOX TURNOUT
SEE DRW. DD-22

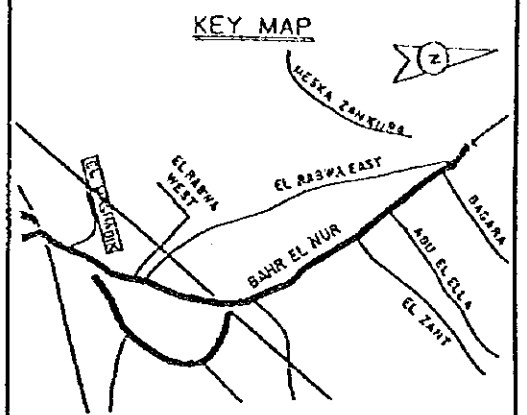

- NOTES:
- (1) THIS DRAWING IS SHOWN AN IMPROVEMENT FOR MESKA (EL MASHABIK CANAL) WATER SUPPLY TO A MALUWA THROUGH A PUMP STATION, NEW MESKA AND MALUWA (TURNOUT BOX).
 - (2) THE LOCATION OF EL MASHABIK CANAL IS INDICATED ON THE DRAWING (FIGURE NO ES-07) IN THE BAHR EL NUR CANAL.
 - (3) THE FOLLOWING DRAWINGS ARE RELATED TO THIS DRAWING.
 - a) TYPICAL DRAWING FOR ONE POINT LIFTING MESKA (FIG. NO DD-21)
 - b) TYPICAL DRAWING FOR OPEN MESKA. (FIG. NO DD-22)
 - c) TYPICAL DRAWING FOR PIPE MESKA (FIG. NO DD-23)
 - d) TYPICAL DRAWING FOR PUMP HOUSE (FIG. NO DD-24)
 - e) MISCELLANEOUS (FIG. NO DD-25)

REFERENCE	
△	TRANSVERSE POINT
□	ICE LEVEL
L.L.	LEFT BANK LEVEL
R.L.	RIGHT BANK LEVEL
SL	LEFT SANTA
SR	RIGHT SANTA
PL	LEFT PUMP
PR	RIGHT PUMP
B	BRIDGE
BC	BRANCH CANAL
CB	CROSS BRAM

JAPAN INTERNATIONAL COOPERATION AGENCY (JICA)
 MINISTRY OF PUBLIC WORKS AND
 WATER RESOURCES (MPWWR)

THE MASTER PLAN STUDY FOR THE IMPROVEMENT OF IRRIGATION
 WATER MANAGEMENT AND ENVIRONMENT CONSERVATION IN
 NORTH-EAST REGION OF THE CENTRAL NILE DELTA

IMPROVEMENT PLAN AND PROFILE
 (EL MASHABIK CANAL)

DATE	MARCH, 1999	FIGURE NO.	DD-13
SANYU CONSULTANTS INC., JAPAN			

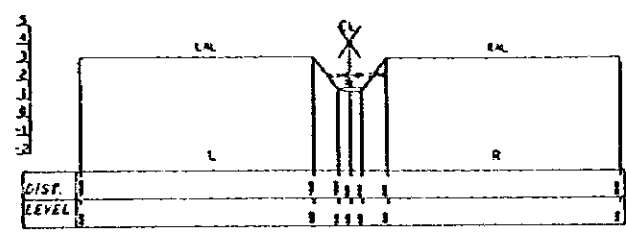

CROSS SECTION 0050 M - No.1

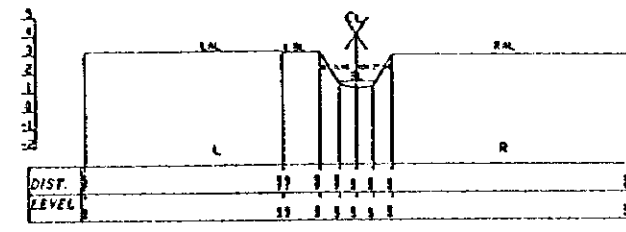

CROSS SECTION 0300 M - No.6

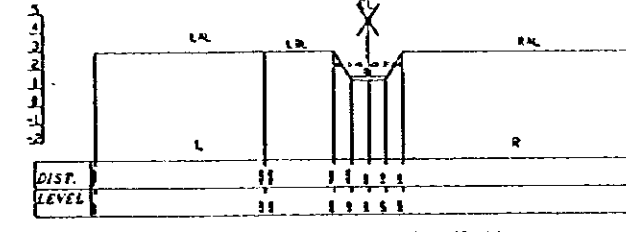

CROSS SECTION 0550 M - No.11

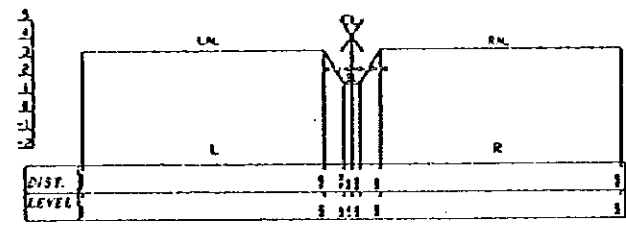

CROSS SECTION 0100 M - No.2

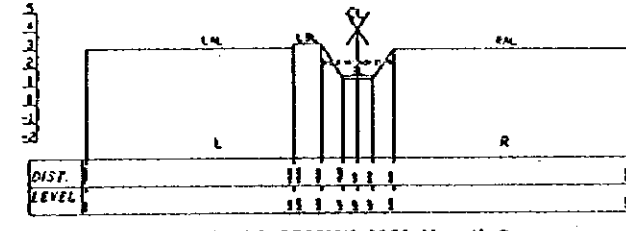

CROSS SECTION 0350 M - No.7

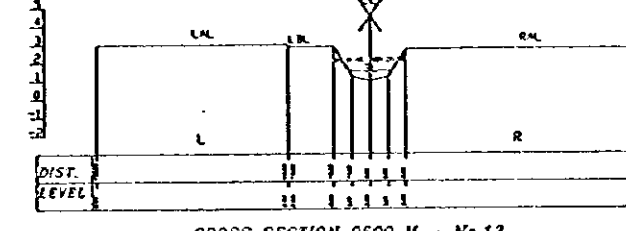

CROSS SECTION 0600 M - No.12

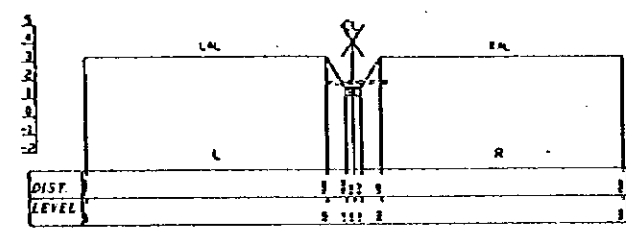

CROSS SECTION 0150 M - No.3

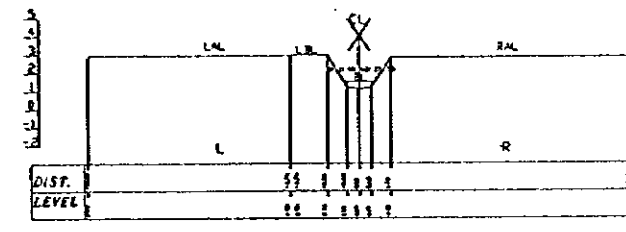

CROSS SECTION 0400 M - No.8

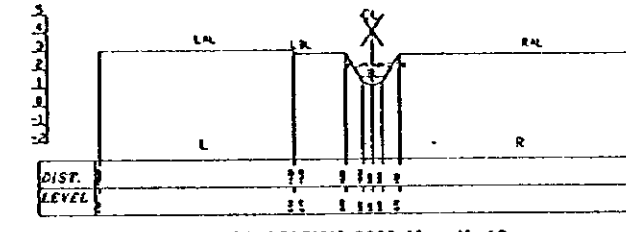

CROSS SECTION 0623 M - No.13

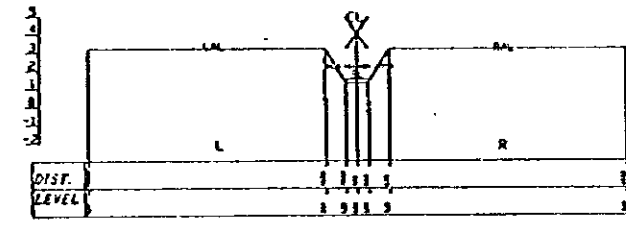

CROSS SECTION 0200 M - No.4

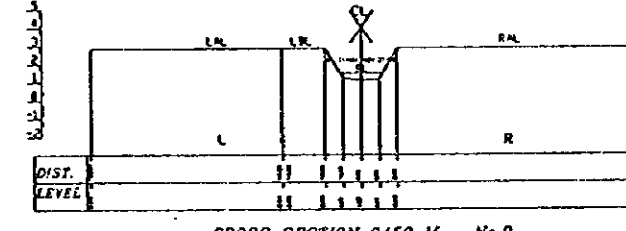

CROSS SECTION 0450 M - No.9

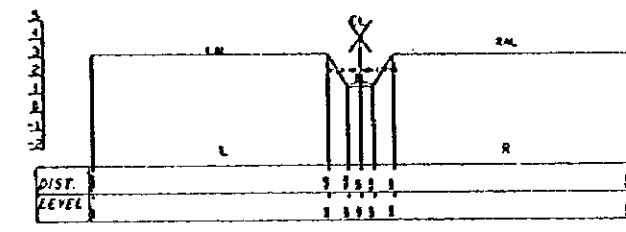

CROSS SECTION 0250 M - No.5

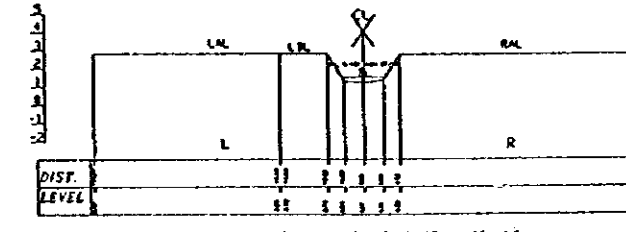

CROSS SECTION 0500 M - No.10

- NOTES :
- (1) THIS DRAWING IS SHOWN AN ORIGINAL CROSS SECTION ALONG THE EL MASHABIK CANAL FOR 50 M INTERVALS.
 - (2) THE FOLLOWING DRAWING AND NOTES ARE RELATED TO THIS DRAWING.
 - a) IMPROVEMENT PLAN AND PROFILE (EL MASHABIK CANAL, FIGURE NO DD-13)
 - b) ALL NOTES INDICATED ON THE FIGURE NO DD-13.

JAPAN INTERNATIONAL COOPERATION AGENCY (JICA)
 MINISTRY OF PUBLIC WORKS AND
 WATER RESOURCES (MPWWR)

THE MASTER PLAN STUDY FOR THE IMPROVEMENT OF IRRIGATION
 WATER MANAGEMENT AND ENVIRONMENT CONSERVATION IN
 NORTH-EAST REGION OF THE CENTRAL NILE DELTA

CROSS SECTION
 IN EL MASHABIK CANAL

DATE	MARCH, 1999	FIGURE NO.	DD-14
SANYU CONSULTANTS INC., JAPAN			

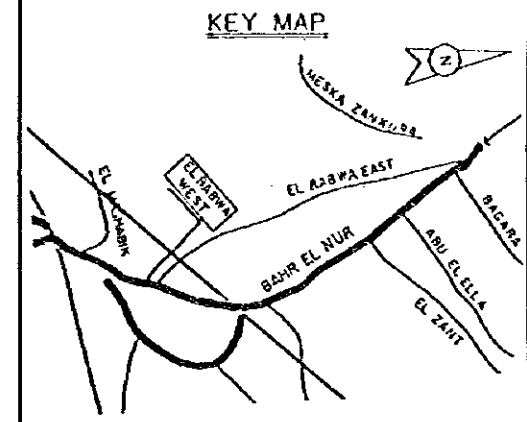
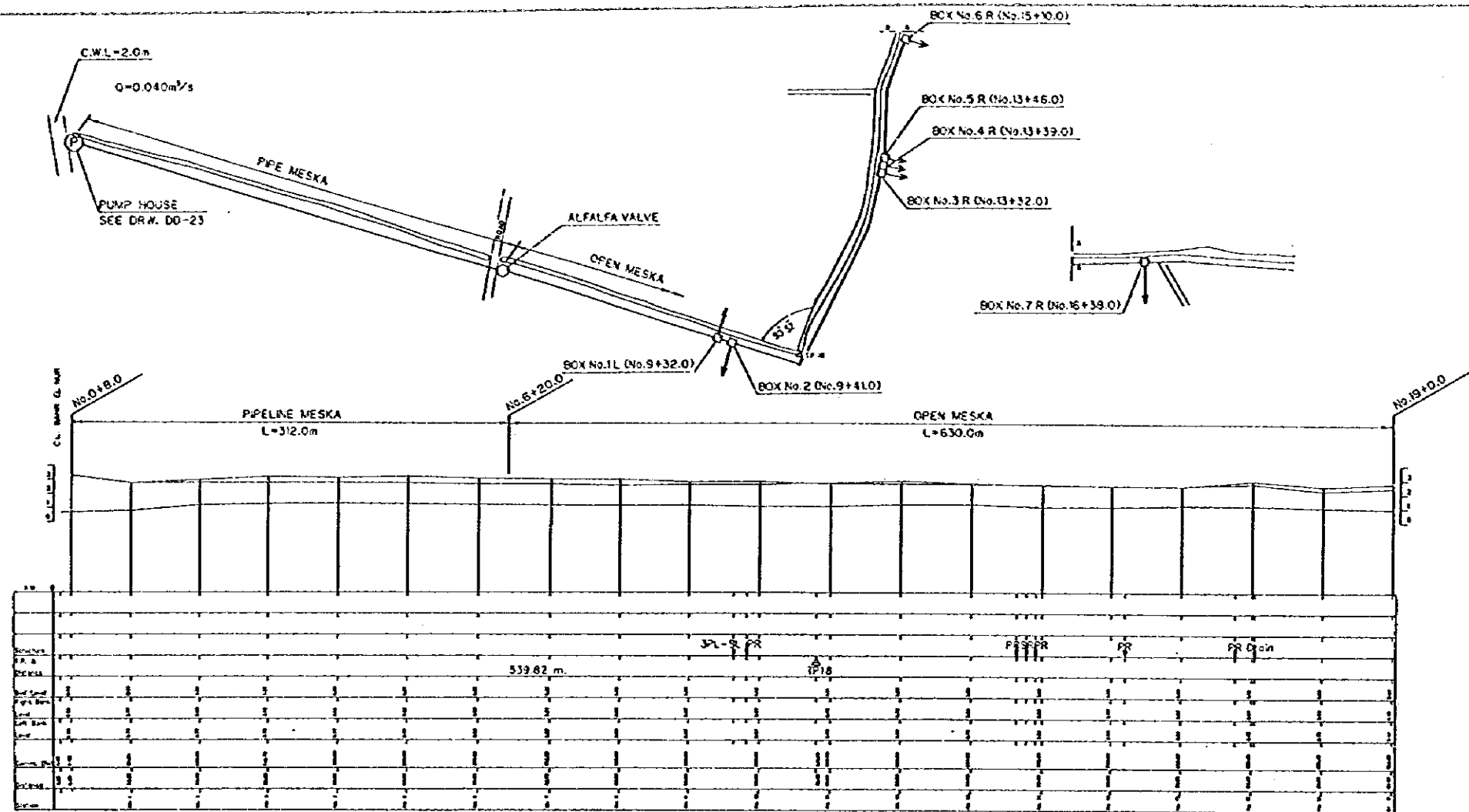

- NOTES:**
- (1) THIS DRAWING IS SHOWN AN IMPROVEMENT FOR MESKA (EL RABWA WEST CANAL) WATER SUPPLY TO A MALWA THROUGH A PUMP STATION, NEW MESKA AND MALWA (TURNOUT BOX).
 - (2) THE LOCATION OF EL RABWA WEST CANAL IS INDICATED ON THE DRAWING (FIGURE NO FS-07) IN THE RABWA EL NUR CANAL.
 - (3) THE FOLLOWING DRAWINGS ARE RELATED TO THIS DRAWING.
 - a) TYPICAL DRAWING FOR ONE POINT LIFTING MESKA (FIG NO DD-21)
 - b) TYPICAL DRAWING FOR OPEN MESKA (FIG NO DD-22)
 - c) TYPICAL DRAWING FOR PIPE MESKA (FIG NO DD-23)
 - d) TYPICAL DRAWING FOR PUMP HOUSE (FIG NO DD-24)
 - e) MISCELLANEOUS (FIG NO DD-25)

Station	Box No. 1.L (No. 9+32.0)	Box No. 2 (No. 9+41.0)	Box No. 3.R (No. 13+32.0)	Box No. 4.R (No. 13+39.0)	Box No. 5.R (No. 13+46.0)	Box No. 6.R (No. 15+10.0)
Water Level						
Bed Level						
Left Bank Level						
Right Bank Level						
Left Sakya						
Right Sakya						
Left Pump						
Right Pump						
Bridge						
Branch Canal						
Cross Drain						

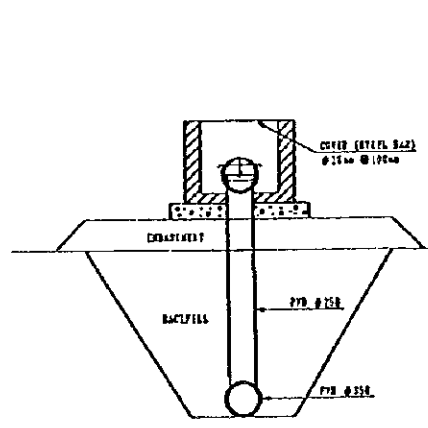

TYPICAL SECTION
PIPELINE MESKA
SEE DRW. DD-23

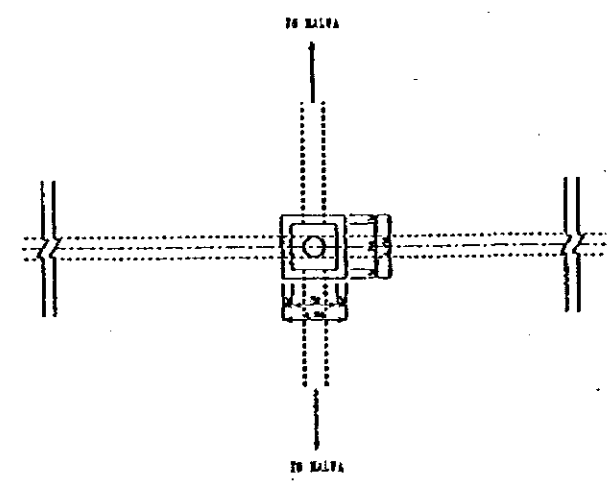

BOX & ALFALFA VALVE
SEE DRW. DD-23

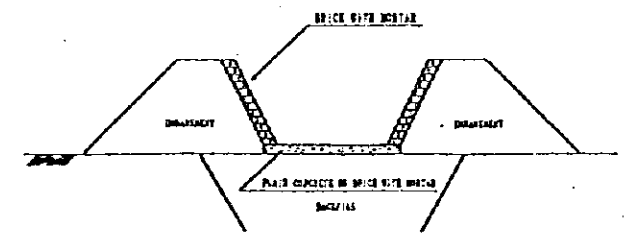

TYPICAL SECTION
OPEN MESKA
SEE DRW. DD-22

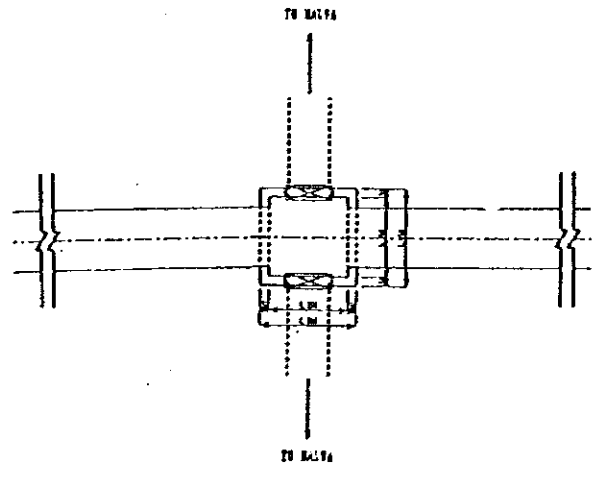

BOX TURNOUT
SEE DRW. DD-23

REFERENCE	
△	TRAVERSE POINT
W	BED LEVEL
L.B.L.	LEFT BANK LEVEL
R.B.L.	RIGHT BANK LEVEL
SL	LEFT SAKYA
SR	RIGHT SAKYA
PL	LEFT PUMP
PR	RIGHT PUMP
B	BRIDGE
BC	BRANCH CANAL
CD	CROSS DRAIN

JAPAN INTERNATIONAL COOPERATION AGENCY (JICA)
MINISTRY OF PUBLIC WORKS AND
WATER RESOURCES (MPWWR)

THE MASTER PLAN STUDY FOR THE IMPROVEMENT OF IRRIGATION
WATER MANAGEMENT AND ENVIRONMENT CONSERVATION IN
NORTH-EAST REGION OF THE CENTRAL NILE DELTA

IMPROVEMENT PLAN AND PROFILE
(EL RABWA WEST CANAL)

DATE MARCH, 1999 FIGURE NO. DD-15

SANYU CONSULTANTS INC., JAPAN

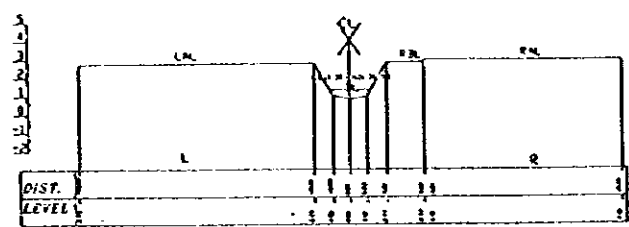

CROSS SECTION 0050 M - No.1

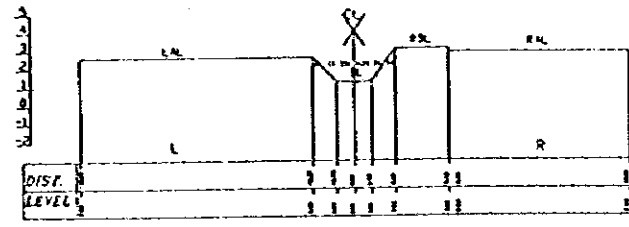

CROSS SECTION 0400 M - No.8

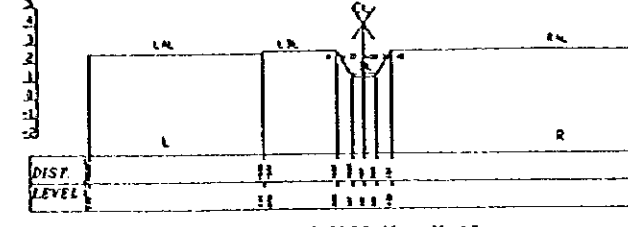

CROSS SECTION 0750 M - No.15

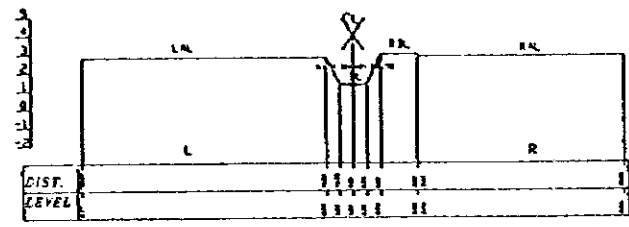

CROSS SECTION 0100 M - No.2

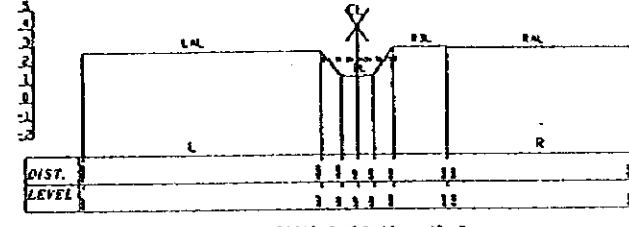

CROSS SECTION 0450 M - No.9

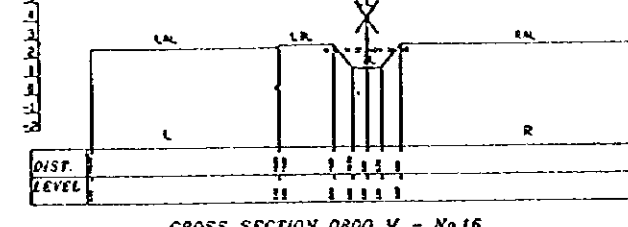

CROSS SECTION 0800 M - No.16

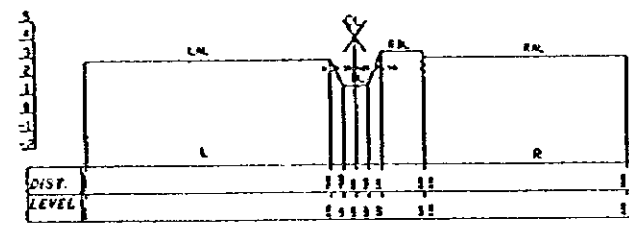

CROSS SECTION 0150 M - No.3

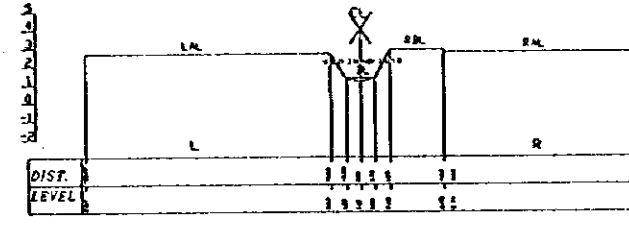

CROSS SECTION 0500 M - No.10

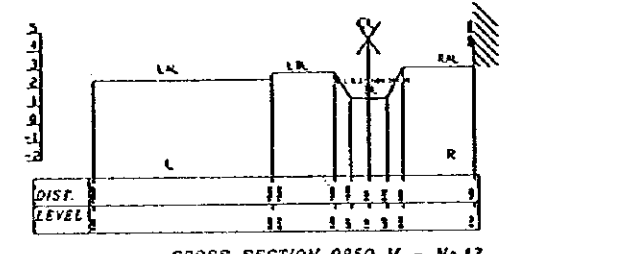

CROSS SECTION 0850 M - No.17

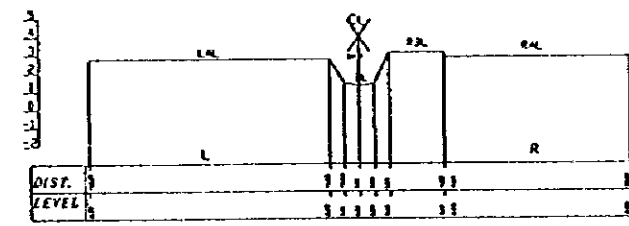

CROSS SECTION 0200 M - No.4

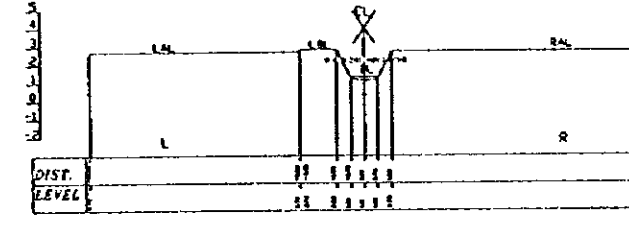

CROSS SECTION 0550 M - No.11

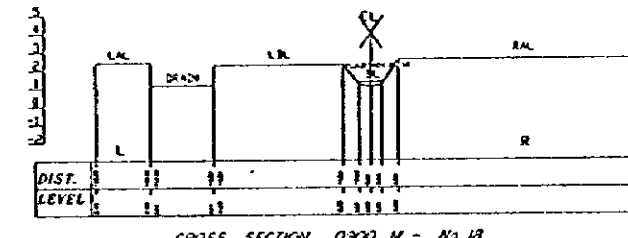

CROSS SECTION 0900 M - No.18

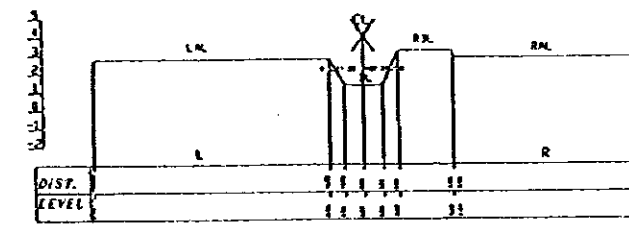

CROSS SECTION 0250 M - No.5

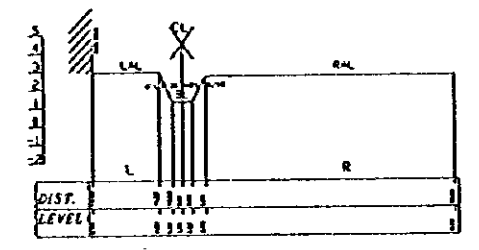

CROSS SECTION 0600 M - No.12

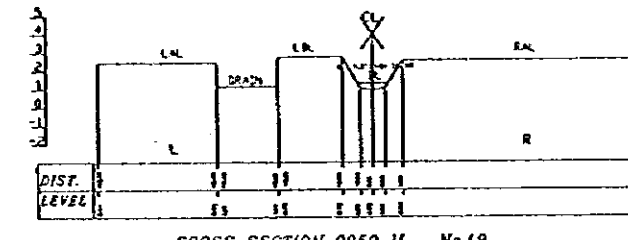

CROSS SECTION 0950 M - No.19

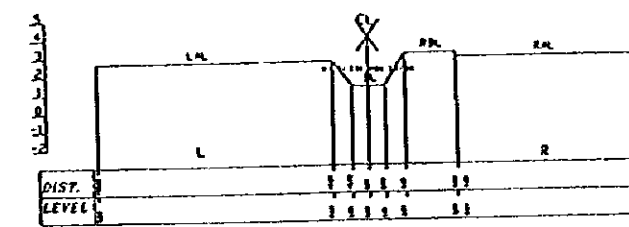

CROSS SECTION 0300 M - No.6

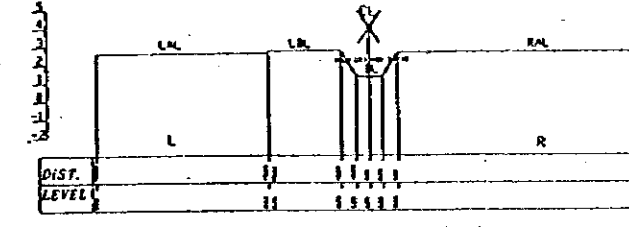

CROSS SECTION 0650 M - No.13

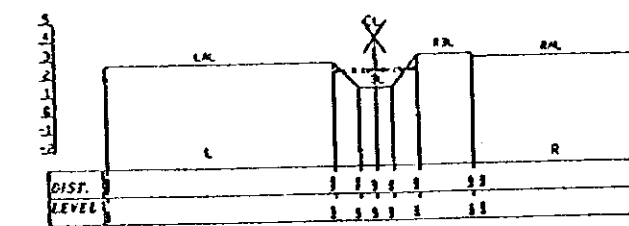

CROSS SECTION 0350 M - No.7

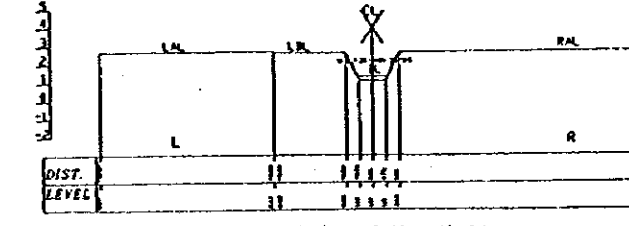

CROSS SECTION 0700 M - No.14

NOTES:

(1) THIS DRAWING IS SHOWN AN ORIGINAL CROSS SECTION ALONG THE EL RABWA WEST CANAL FOR 50 M INTERVALS.

(2) THE FOLLOWING DRAWING AND NOTES ARE RELATED TO THIS DRAWING.

- a) IMPROVEMENT PLAN AND PROFILE (EL MASARA CANAL, FIGURE NO DD-13).
- b) ALL NOTES INDICATED ON THE FIGURE NO DD-15.

JAPAN INTERNATIONAL COOPERATION AGENCY (JICA)
MINISTRY OF PUBLIC WORKS AND
WATER RESOURCES (MPWWR)

THE MASTER PLAN STUDY FOR THE IMPROVEMENT OF IRRIGATION
WATER MANAGEMENT AND ENVIRONMENT CONSERVATION IN
NORTH-EAST REGION OF THE CENTRAL NILE DELTA

CROSS SECTION IN
EL RABWA WEST CANAL

DATE MARCH, 1999 FIGURE NO. DD-16

SANTU CONSULTANTS INC., JAPAN

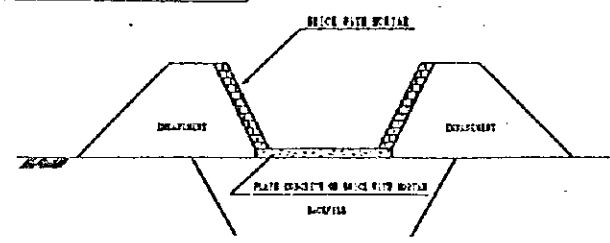
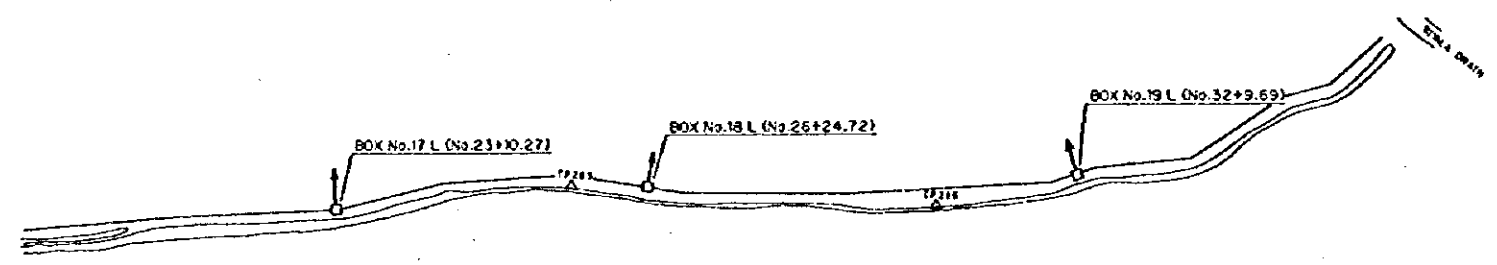
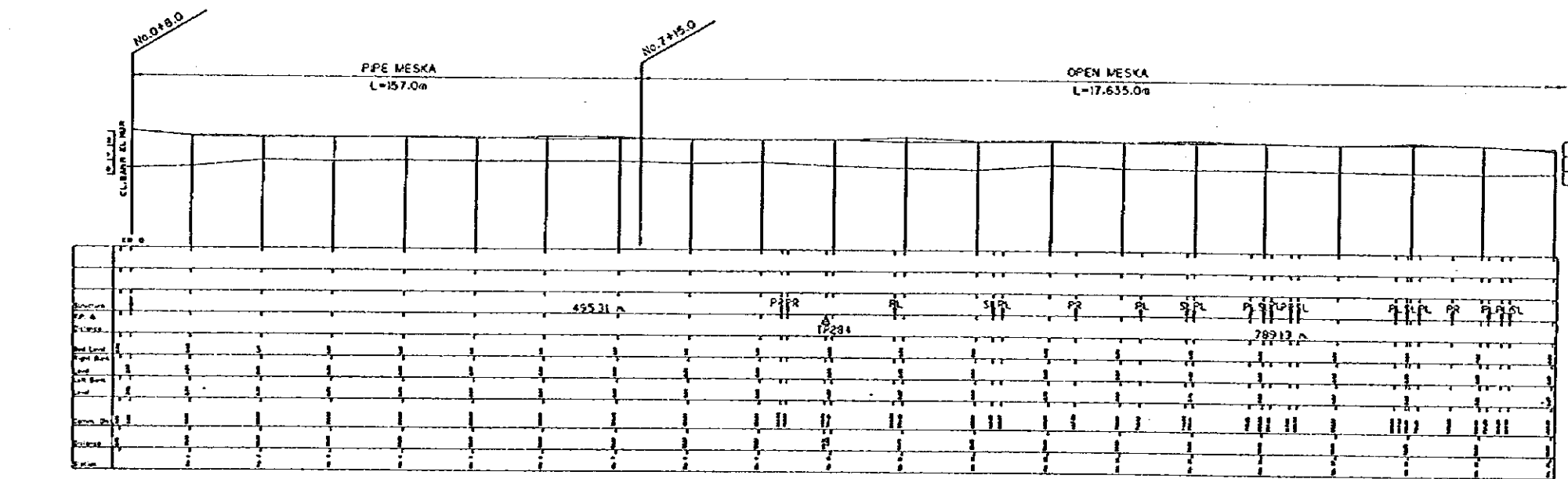
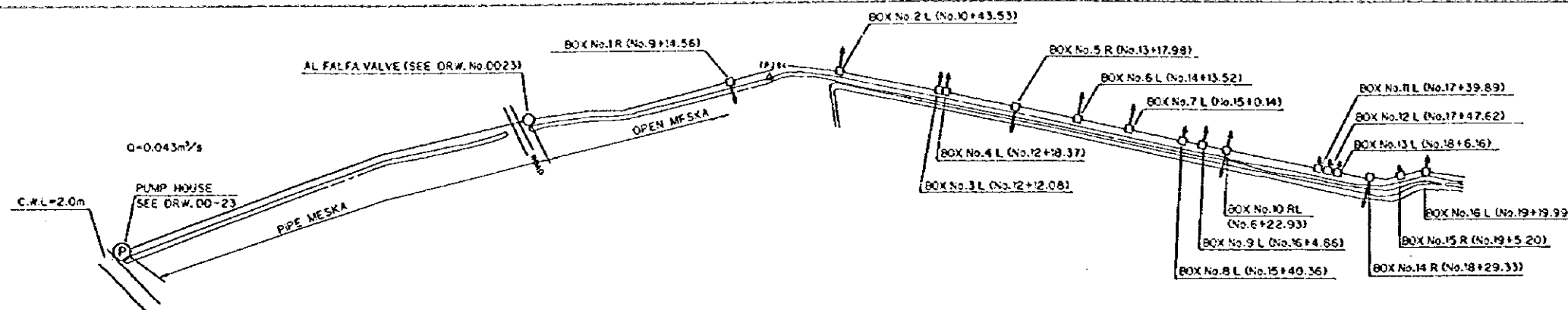

TYPICAL SECTION
OPEN MESKA
SEE DRW. DO-22

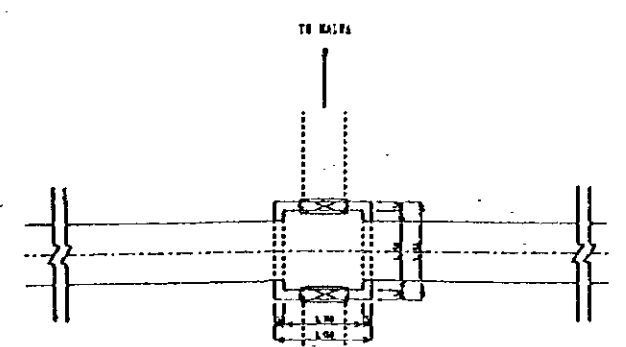
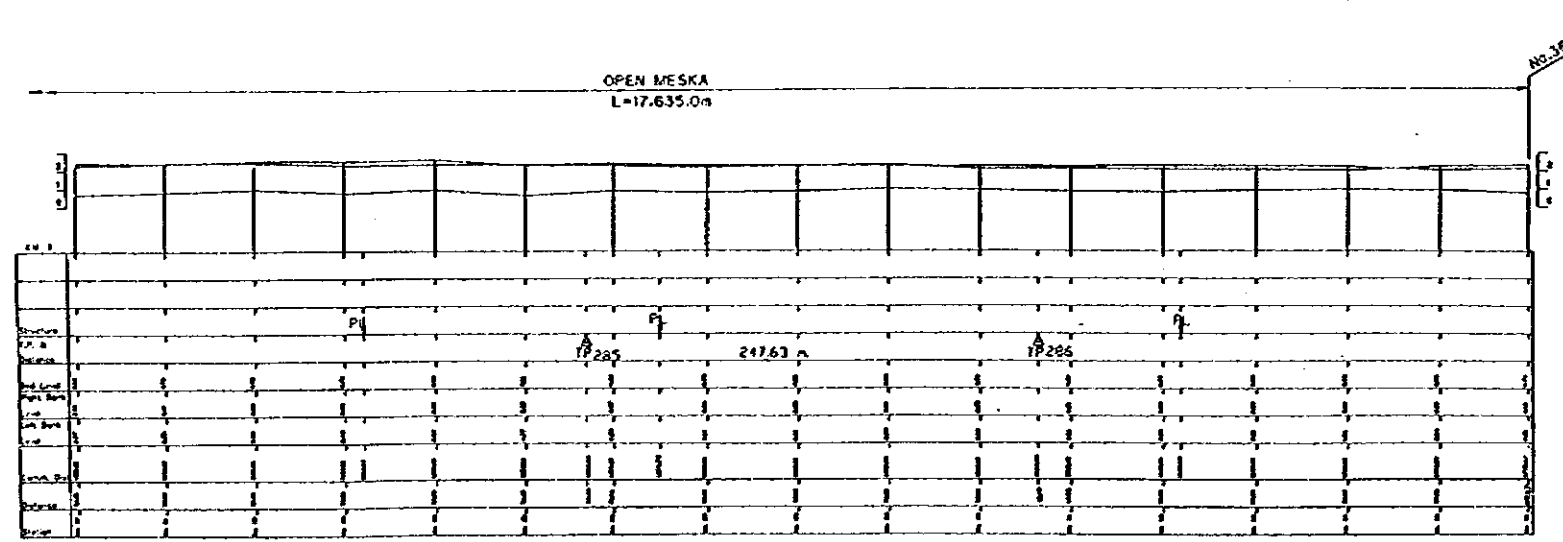

TYPICAL SECTION
BOX TURNOUT
SEE DRW. DO-22

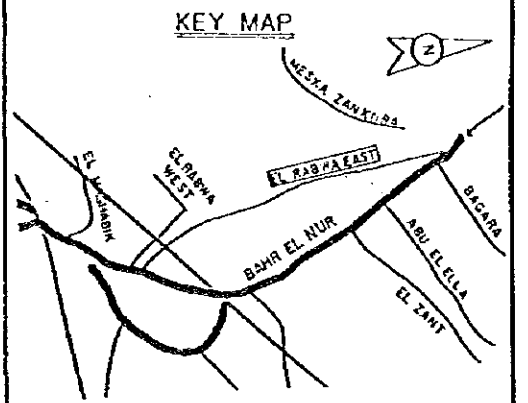

- NOTES :
- (1) THIS DRAWING IS SHOWN AN IMPROVEMENT FOR MESKA (EL RABWA EAST CANAL) WATER SUPPLY TO A MALUWA THROUGH A PUMP STATION, NEW MESKA AND MALUWA (TURNOUT BOX).
 - (2) THE LOCATION OF EL RABWA EAST CANAL IS INDICATED ON THE DRAWING (FIGURE NO FS-67) IN THE BAHAR EL NUR CANAL.
 - (3) THE FOLLOWING DRAWINGS ARE RELATED TO THIS DRAWING.
 - a) TYPICAL DRAWING FOR ONE POINT LIFTING MESKA (FIG. NO DD-21)
 - b) TYPICAL DRAWING FOR OPEN MESKA (FIG. NO DD-22)
 - c) TYPICAL DRAWING FOR PIPE MESKA (FIG. NO DD-23)
 - d) TYPICAL DRAWING FOR PUMP HOUSE (FIG. NO DD-24)
 - e) MISCELLANEOUS (FIG. NO DD-25)

REFERENCE	
△	TRAVERSE POINT
R	BED LEVEL
L.R.	LEFT BANK LEVEL
R.R.	RIGHT BANK LEVEL
SL	LEFT SAKYA
SR	RIGHT SAKYA
PL	LEFT PUMP
PR	RIGHT PUMP
B	BRIDGE
BC	BRANCH CANAL
CD	CROSS DRAIN

JAPAN INTERNATIONAL COOPERATION AGENCY (JICA)
 MINISTRY OF PUBLIC WORKS AND
 WATER RESOURCES (MPWWR)

THE MASTER PLAN STUDY FOR THE IMPROVEMENT OF IRRIGATION
 WATER MANAGEMENT AND ENVIRONMENT CONSERVATION IN
 NORTH-EAST REGION OF THE CENTRAL NILE DELTA

IMPROVEMENT PLAN AND PROFILE
 (EL RABWA EAST CANAL)

DATE MARCH, 1999 FIGURE NO. DD-17
 SANYU CONSULTANTS INC., JAPAN

- NOTES:
- (1) THIS DRAWING IS SHOWN AN ORIGINAL CROSS SECTION ALONG THE EL RABWA EAST CANAL FOR 50 M INTERVALS.
 - (2) THE FOLLOWING DRAWING AND NOTES ARE RELATED TO THIS DRAWING
 - a) IMPROVEMENT PLAN AND PROFILE (EL RABWA EAST CANAL, FIGURE NO DD-17).
 - b) ALL NOTES INDICATED ON THE FIGURE NO DD-17.

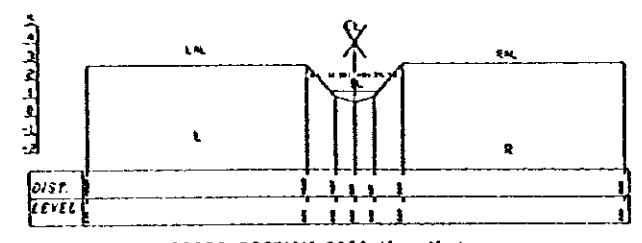

CROSS SECTION 0050 M - No.1

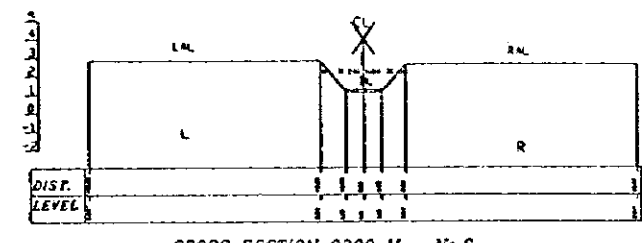

CROSS SECTION 0300 M - No.6

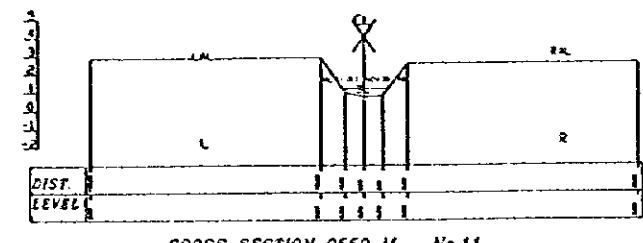

CROSS SECTION 0550 M - No.11

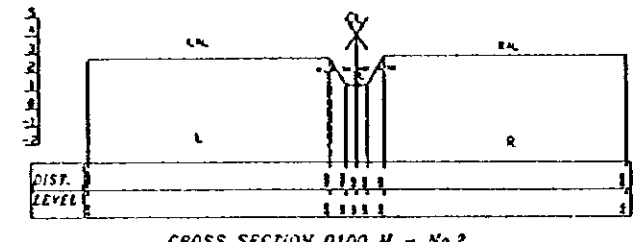

CROSS SECTION 0100 M - No.2

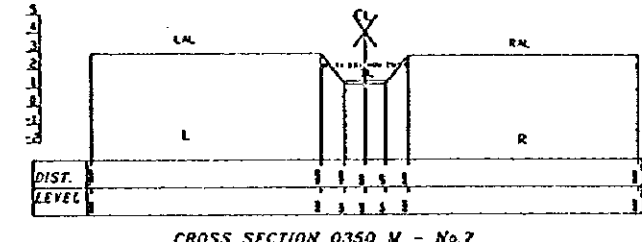

CROSS SECTION 0350 M - No.7

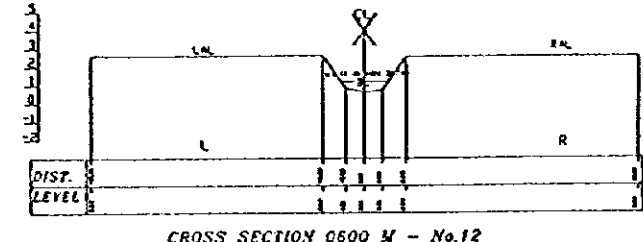

CROSS SECTION 0600 M - No.12

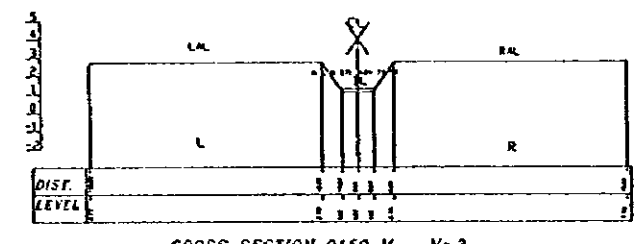

CROSS SECTION 0150 M - No.3

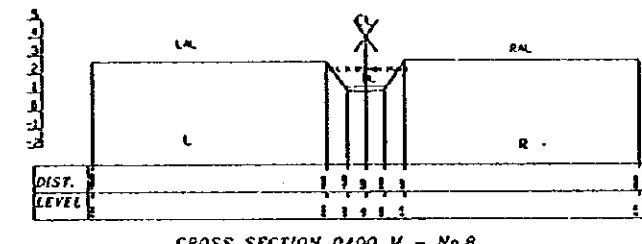

CROSS SECTION 0400 M - No.8

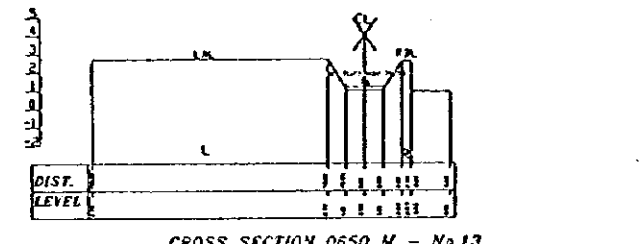

CROSS SECTION 0650 M - No.13

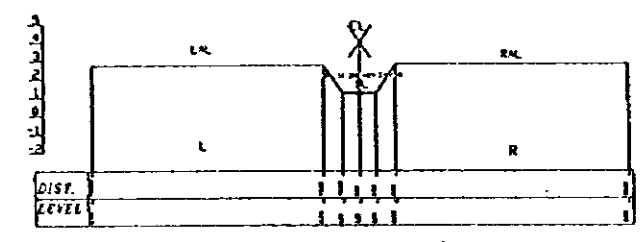

CROSS SECTION 0200 M - No.4

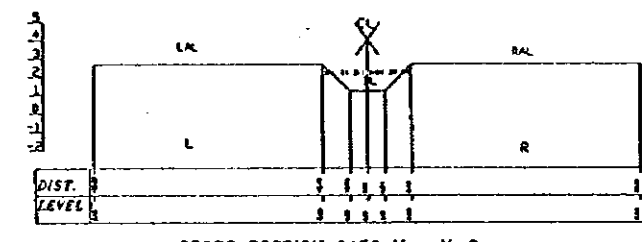

CROSS SECTION 0450 M - No.9

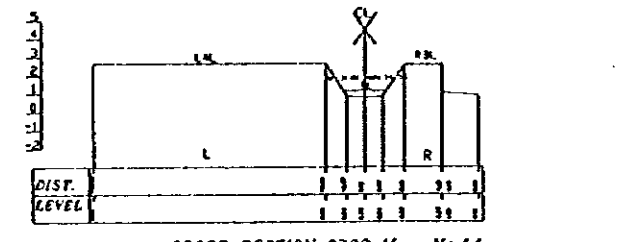

CROSS SECTION 0700 M - No.14

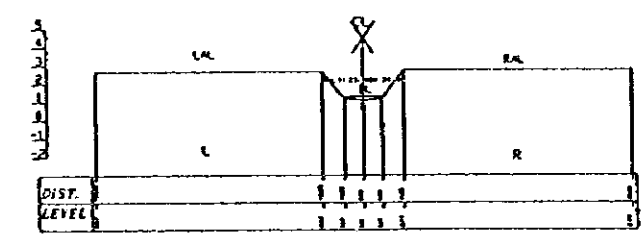

CROSS SECTION 0250 M - No.5

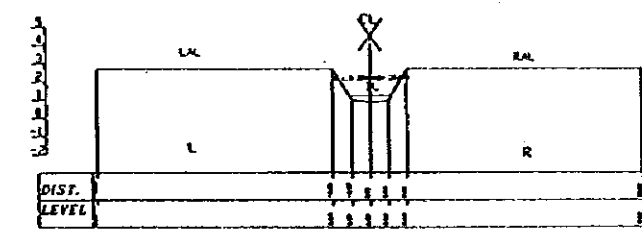

CROSS SECTION 0500 M - No.10

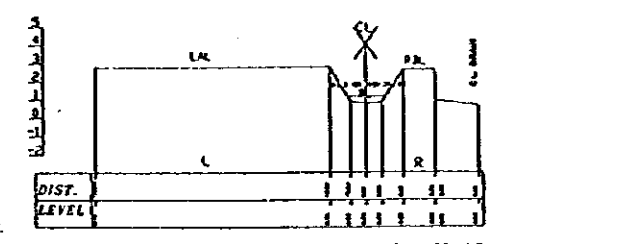

CROSS SECTION 0750 M - No.15

JAPAN INTERNATIONAL COOPERATION AGENCY (JICA)
 MINISTRY OF PUBLIC WORKS AND
 WATER RESOURCES (MPWWR)

THE MASTER PLAN STUDY FOR THE IMPROVEMENT OF IRRIGATION
 WATER MANAGEMENT AND ENVIRONMENT CONSERVATION IN
 NORTH-EAST REGION OF THE CENTRAL NILE DELTA

CROSS SECTION IN
 EL RABWA EAST CANAL (1/3)

DATE	MARCH, 1999	FIGURE NO.	DD-18
------	-------------	------------	-------

SANYU CONSULTANTS INC., JAPAN

NOTES :

(1) THIS DRAWING IS SHOWN AN ORIGINAL CROSS SECTION ALONG THE EL RABWA EAST CANAL FOR 50 M INTERVALS

(2) THE FOLLOWING DRAWING AND NOTES ARE RELATED TO THIS DRAWING

a) IMPROVEMENT PLAN AND PROFILE (EL RABWA EAST CANAL, FIGURE NO DD-17).

b) ALL NOTES INDICATED ON THE FIGURE NO DD-17.

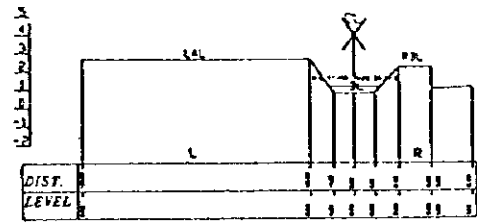

CROSS SECTION 0800 M - No.16

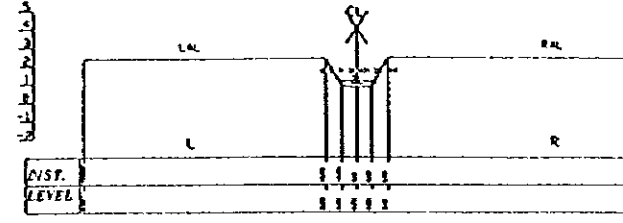

CROSS SECTION 1050 M - No.21

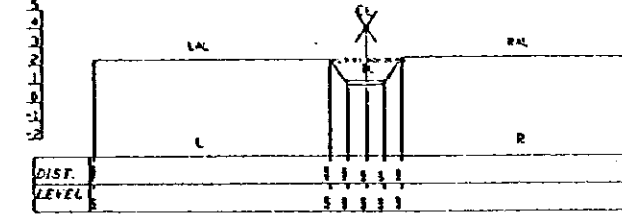

CROSS SECTION 1300 M - No.26

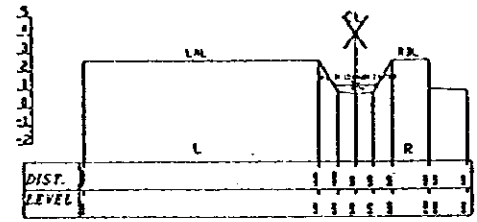

CROSS SECTION 0850 M - No.17

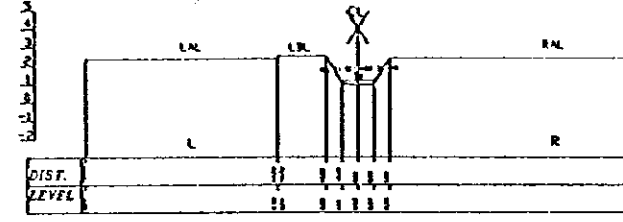

CROSS SECTION 1100 M - No.22

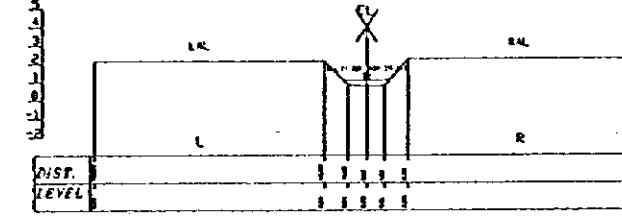

CROSS SECTION 1350 M - No.27

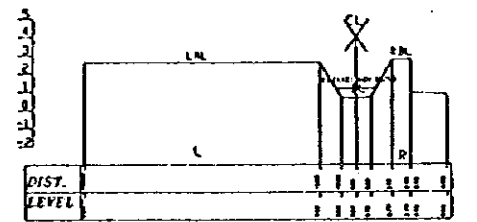

CROSS SECTION 0900 M - No.18

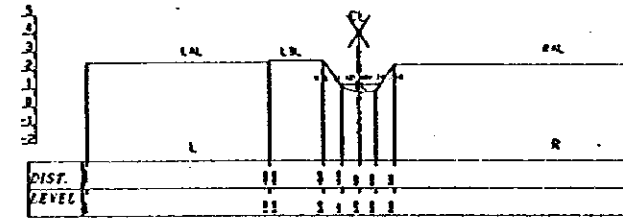

CROSS SECTION 1150 M - No.23

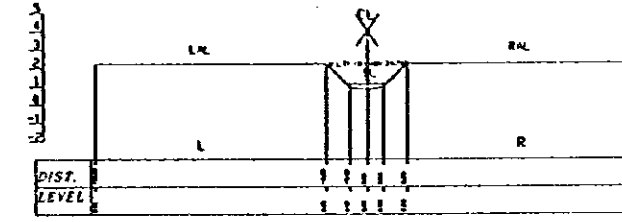

CROSS SECTION 1400 M - No.28

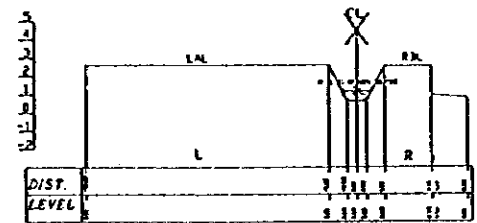

CROSS SECTION 0950 M - No.19

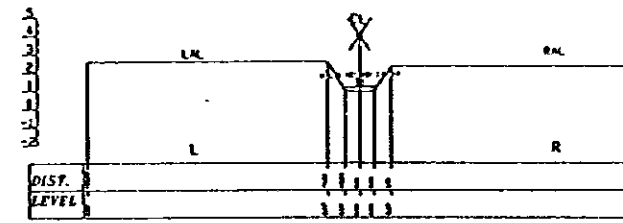

CROSS SECTION 1200 M - No.24

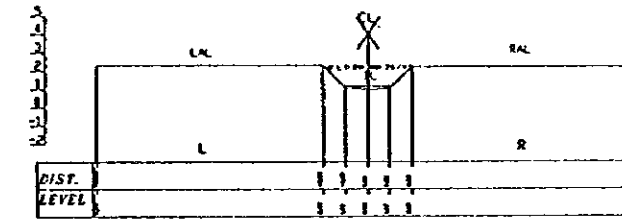

CROSS SECTION 1450 M - No.29

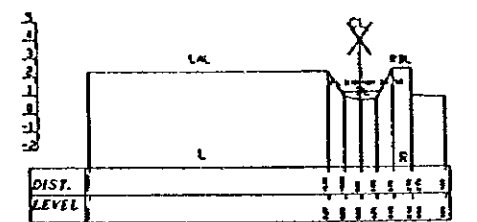

CROSS SECTION 1000 M - No.20

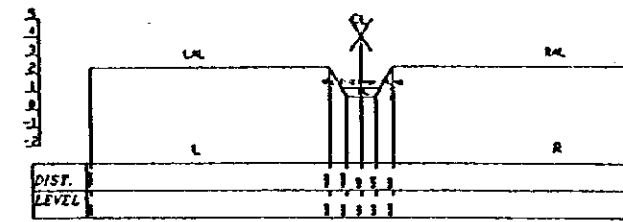

CROSS SECTION 1250 M - No.25

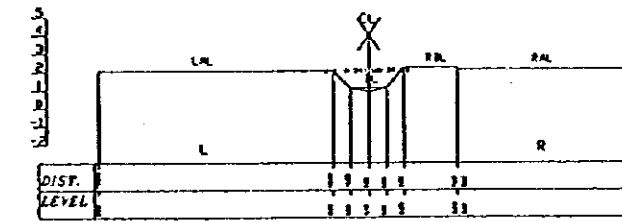

CROSS SECTION 1500 M - No.30

JAPAN INTERNATIONAL COOPERATION AGENCY (JICA)
MINISTRY OF PUBLIC WORKS AND
WATER RESOURCES (MPWWR)

THE MASTER PLAN STUDY FOR THE IMPROVEMENT OF IRRIGATION
WATER MANAGEMENT AND ENVIRONMENT CONSERVATION IN
NORTH-EAST REGION OF THE CENTRAL NILE DELTA

CROSS SECTION IN
EL RABWA EAST CANAL (2/3)

DATE	MARCH, 1999	FIGURE NO.	DD-19
------	-------------	------------	-------

SANTU CONSULTANTS INC., JAPAN

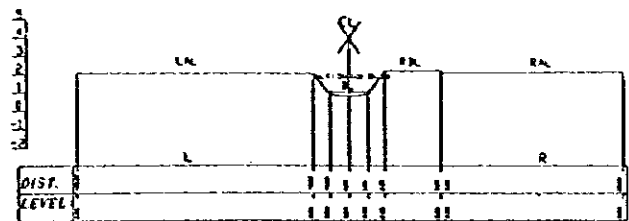

CROSS SECTION 1550 M - No.31

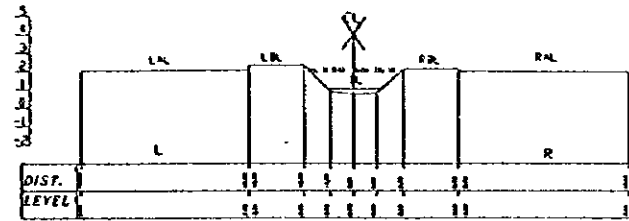

CROSS SECTION 1750 M - No.35

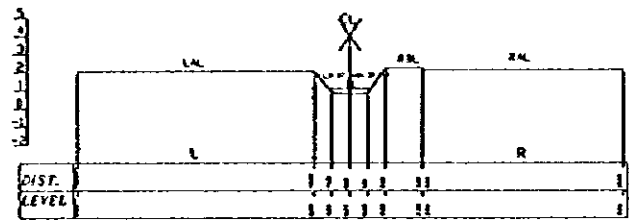

CROSS SECTION 1600 M - No.32

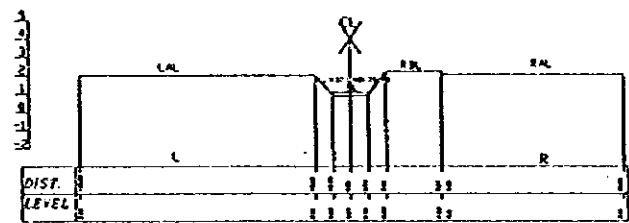

CROSS SECTION 1650 M - No.33

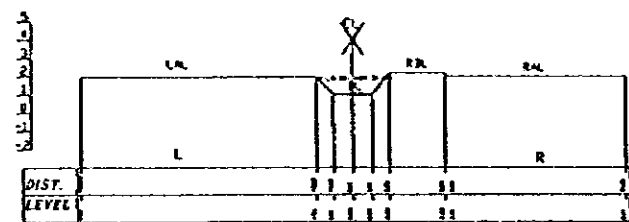

CROSS SECTION 1700 M - No.34

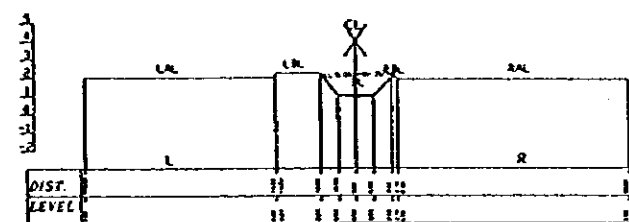

CROSS SECTION 1750 M - No.35

NOTES:

- (1) THIS DRAWING IS SHOWN AN ORIGINAL CROSS SECTION ALONG THE EL RABWA EAST CANAL FOR 50 M INTERVALS.
- (2) THE FOLLOWING DRAWING AND NOTES ARE RELATED TO THIS DRAWING
 - a) IMPROVEMENT PLAN AND PROFILE (EL RABWA EAST CANAL, FIGURE NO DD-17)
 - b) ALL NOTES INDICATED ON THE FIGURE NO DD-17.

JAPAN INTERNATIONAL COOPERATION AGENCY (JICA)
 MINISTRY OF PUBLIC WORKS AND
 WATER RESOURCES (MPWWR)

THE MASTER PLAN STUDY FOR THE IMPROVEMENT OF IRRIGATION
 WATER MANAGEMENT AND ENVIRONMENT CONSERVATION IN
 NORTH-EAST REGION OF THE CENTRAL NILE DELTA

CROSS SECTION IN
 EL RABWA EAST CANAL (3/3)

DATE	MARCH, 1999	FIGURE NO.	DD-20
------	-------------	------------	-------

SANYU CONSULTANTS INC., JAPAN

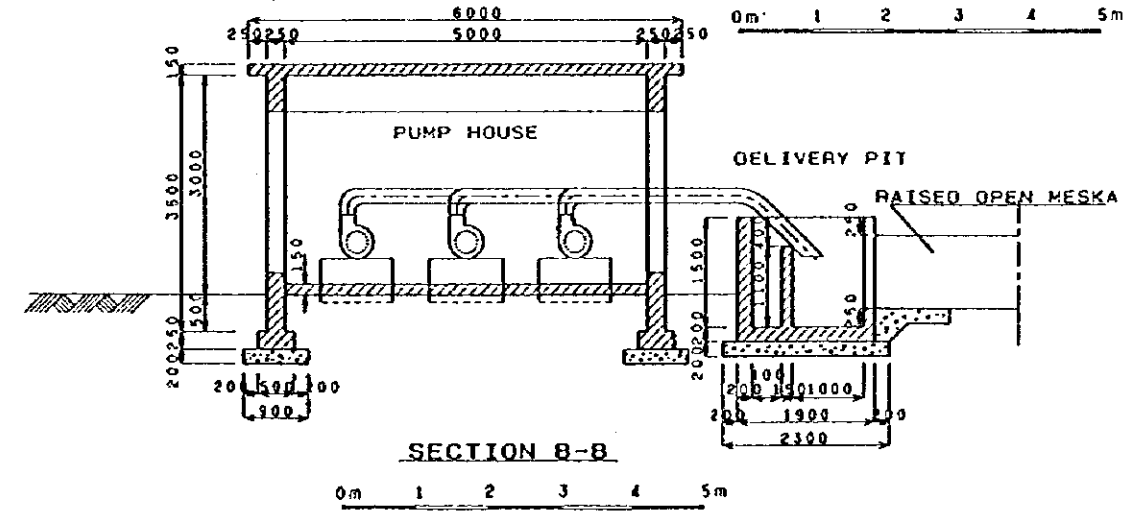
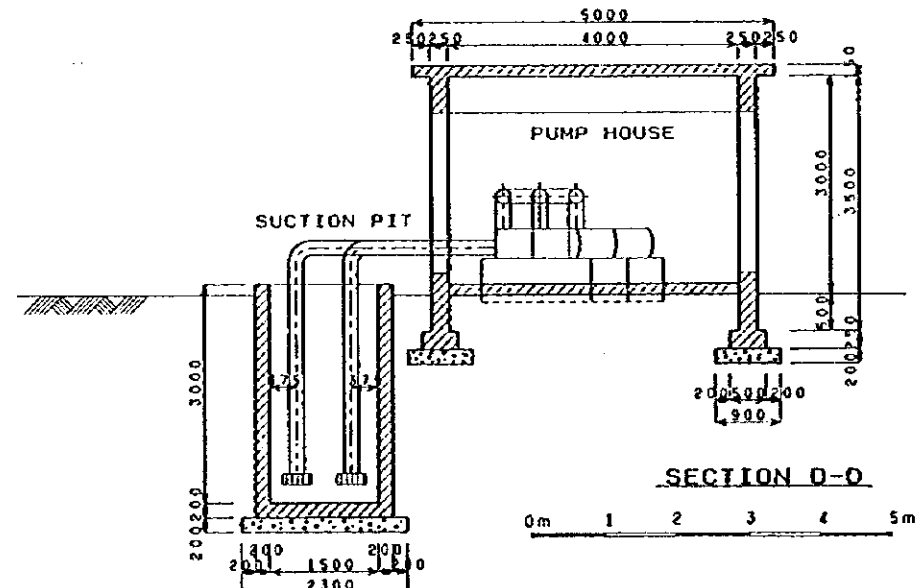
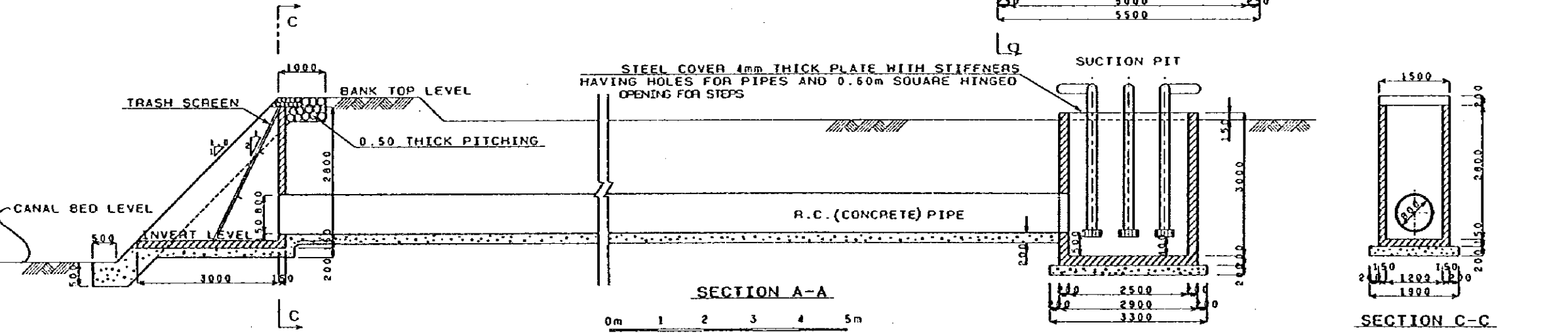
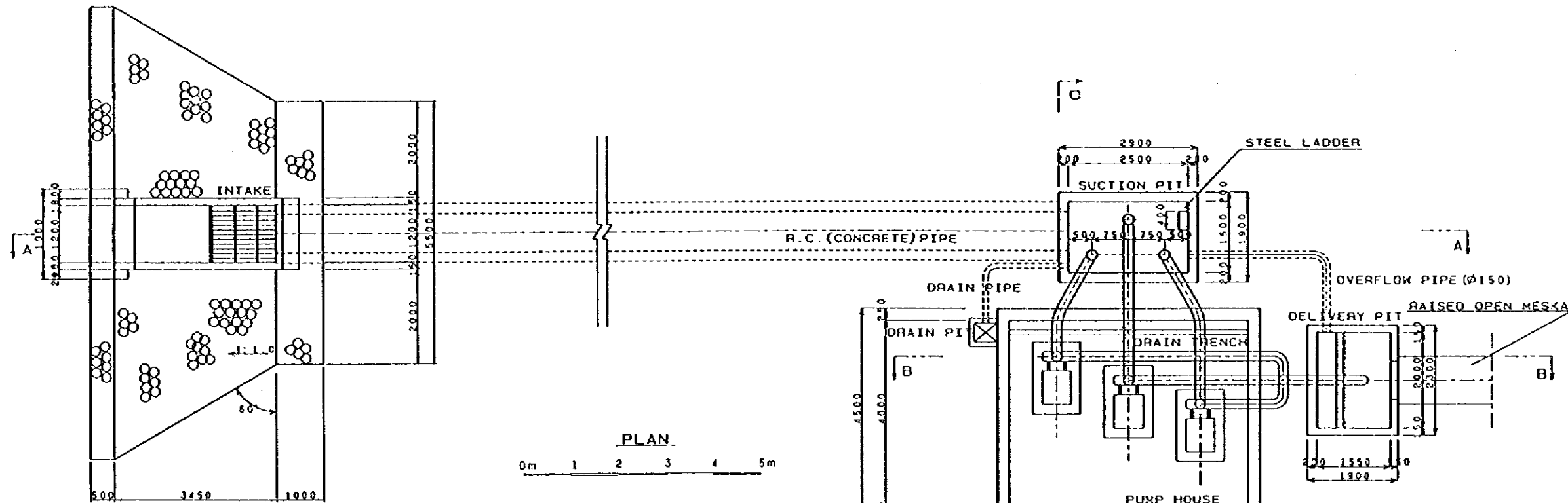

NOTES :

- (1) THIS DRAWING IS SHOWN A TYPICAL DRAWING FOR ONE POINT LIFTING MESKA BETWEEN INLET WORK AND OUTLET WORK OF THE PUMP STATION.
- (2) THE FOLLOWING FOUR (4) DRAWINGS ARE RELATED TO THE MESKA IMPROVEMENT WORK :
 - a) TYPICAL DRAWING FOR OPEN MESKA (FIGURE NO DD-22)
 - b) TYPICAL DRAWING FOR PIPE MESKA (FIGURE NO DD-23)
 - c) TYPICAL DRAWING FOR PUMP HOUSE (FIGURE NO DD-24)
 - d) MISCELLANEOUS (FIGURE NO DD-25)
- (3) THE MAIN STRUCTURES AND IMPLEMENTATION WORK WILL BE CARRIED OUT BY THE FOLLOWING SPECIFICATIONS TO BE APPROVED BY THE IIS.
 - a) CIVIL WORK
THE CIVIL WORK IS INCLUDING SPECIFICATIONS FOR EARTH WORK, CONCRETE, BRICK WORK AND MISCELLANEOUS.
 - b) PROCUREMENT OF EQUIPMENT
THE PROCUREMENT OF EQUIPMENT IS INCLUDING PUMPS AND APPARATUS.

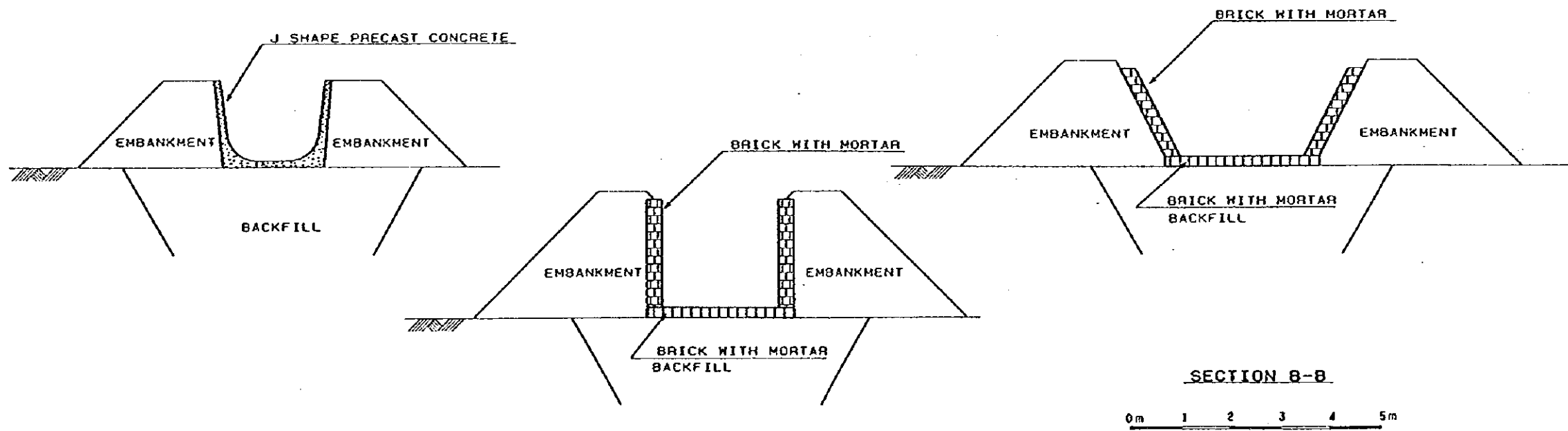
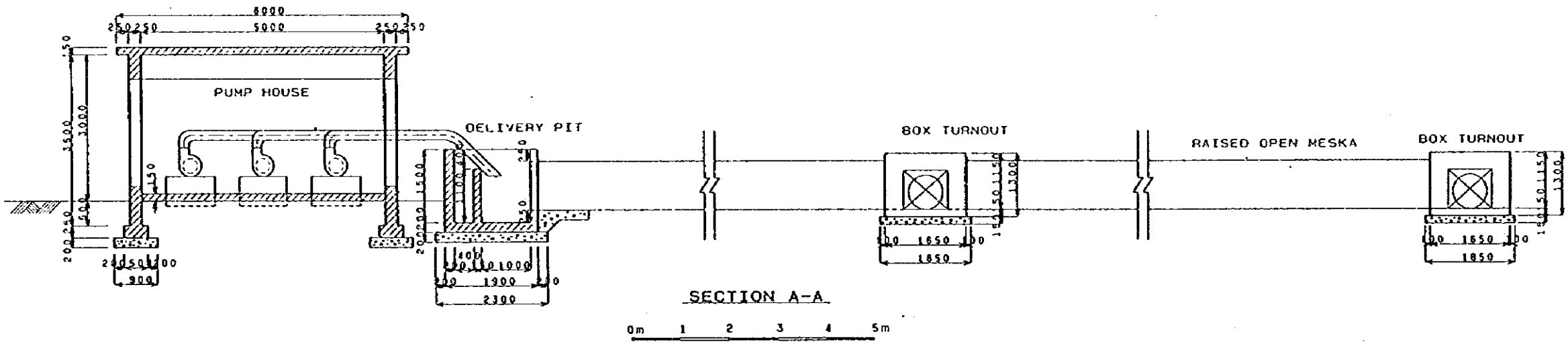
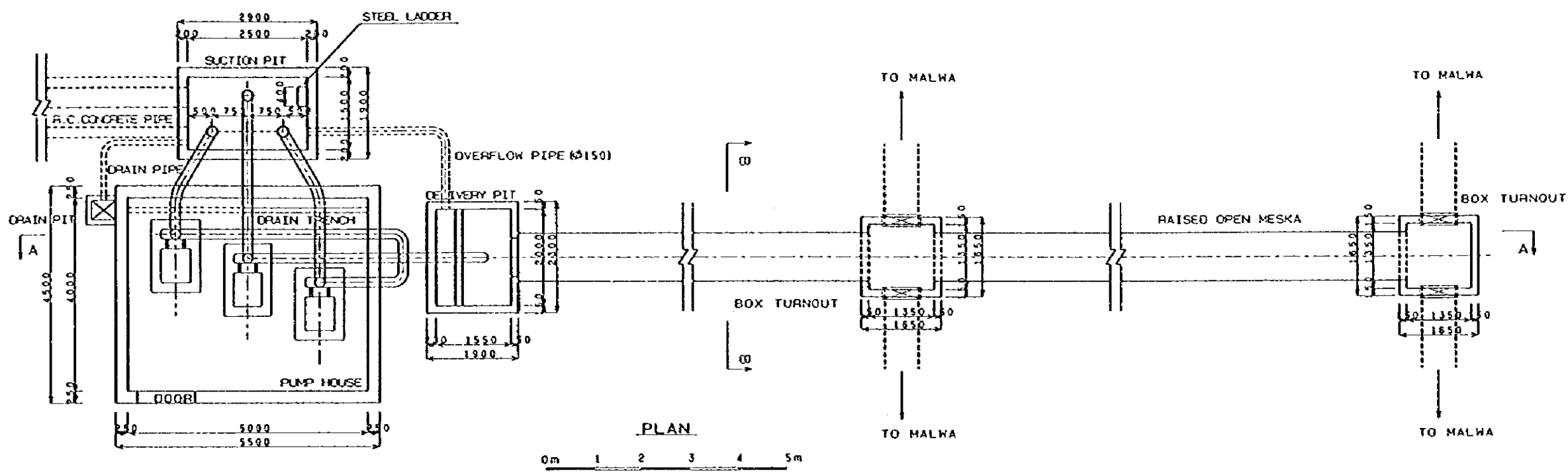

NOTES :

(1) THIS DRAWING IS SHOWN ATYPICAL DRAWING FOR ONE POINT LIFTING MESKA BETWEEN INLET WORK AND OUTLET WORK OF THE PUMP STATION.

(2) THE FOLLOWING FOUR (4) DRAWINGS ARE RELATED TO THE MESKA IMPROVEMENT WORK :

- a) TYPICAL DRAWING FOR OPEN MESKA (FIGURE NO DD-22)
- b) TYPICAL DRAWING FOR PIPE MESKA (FIGURE NO DD-23)
- c) TYPICAL DRAWING FOR PUMP HOUSE (FIGURE NO DD-24)
- d) MISCELLANEOUS (FIGURE NO DD-25)

(3) THE MAIN STRUCTURES AND IMPLEMENTATION WORK WILL BE CARRIED OUT BY THE FOLLOWING SPECIFICATIONS TO BE APPROVED BY THE IIS.

- a) CIVIL WORK
THE CIVIL WORK IS REFERRED THE IIS SPECIFICATIONS FOR EARTH WORK, CONCRETE, BRICK WORK AND MISCELLANEOUS.
- b) PROCUREMENT OF EQUIPMENT
THE PROCUREMENT OF EQUIPMENT IS INCLUDING PUMPS AND APPARATUS.

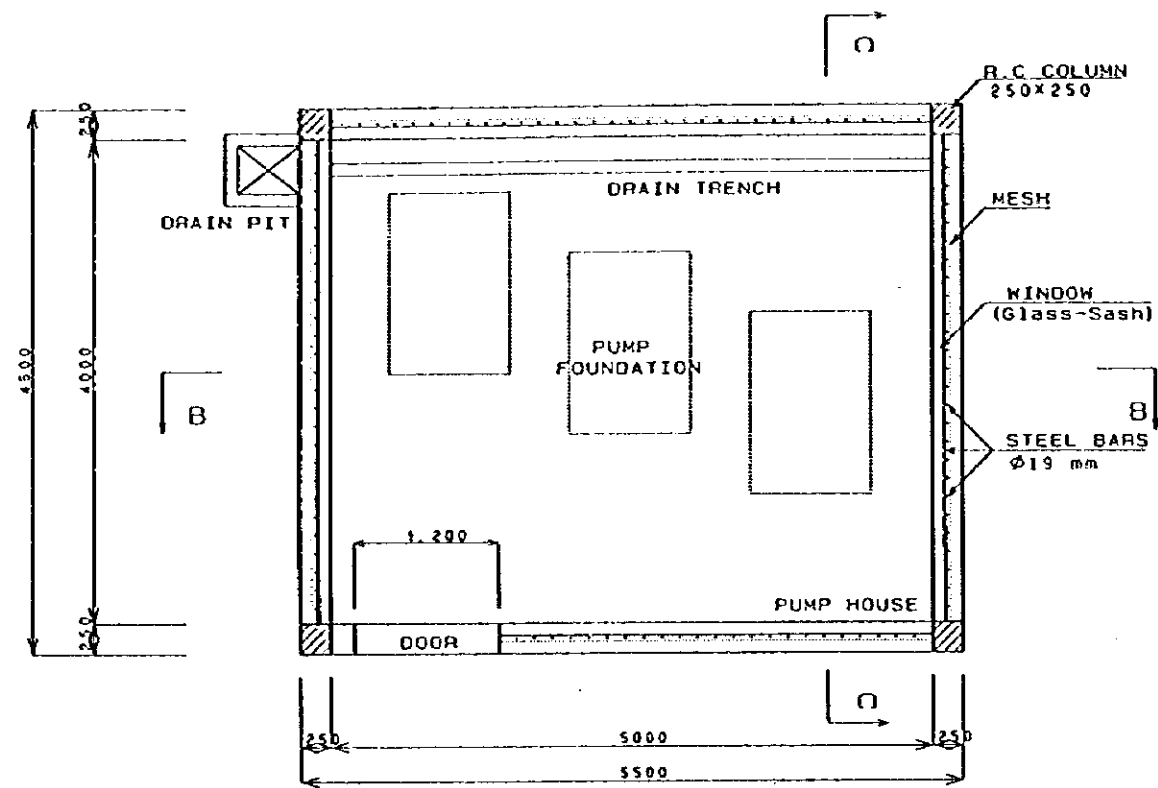

PLAN ON A-A

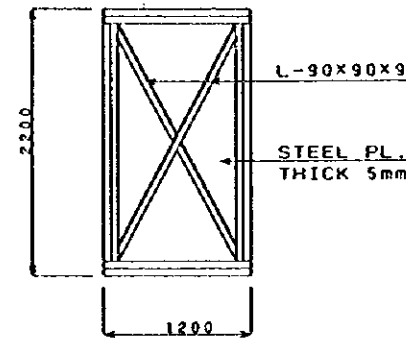

DETAIL OF DOOR

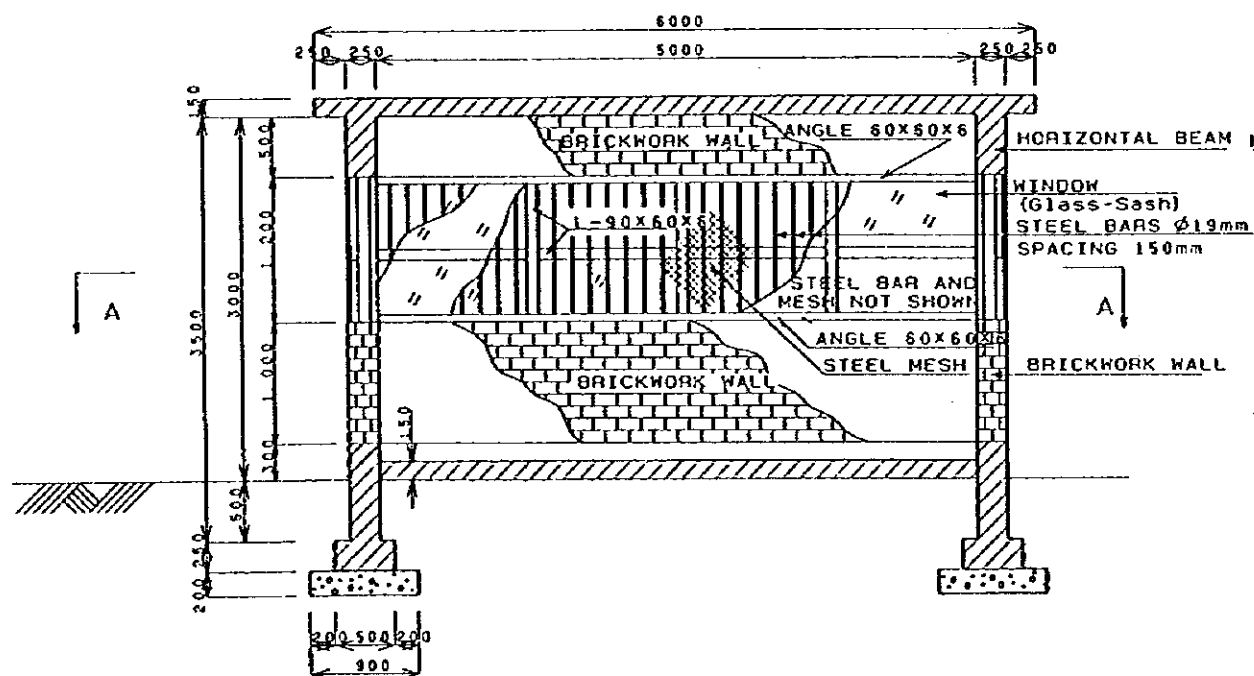

SECTION B-B

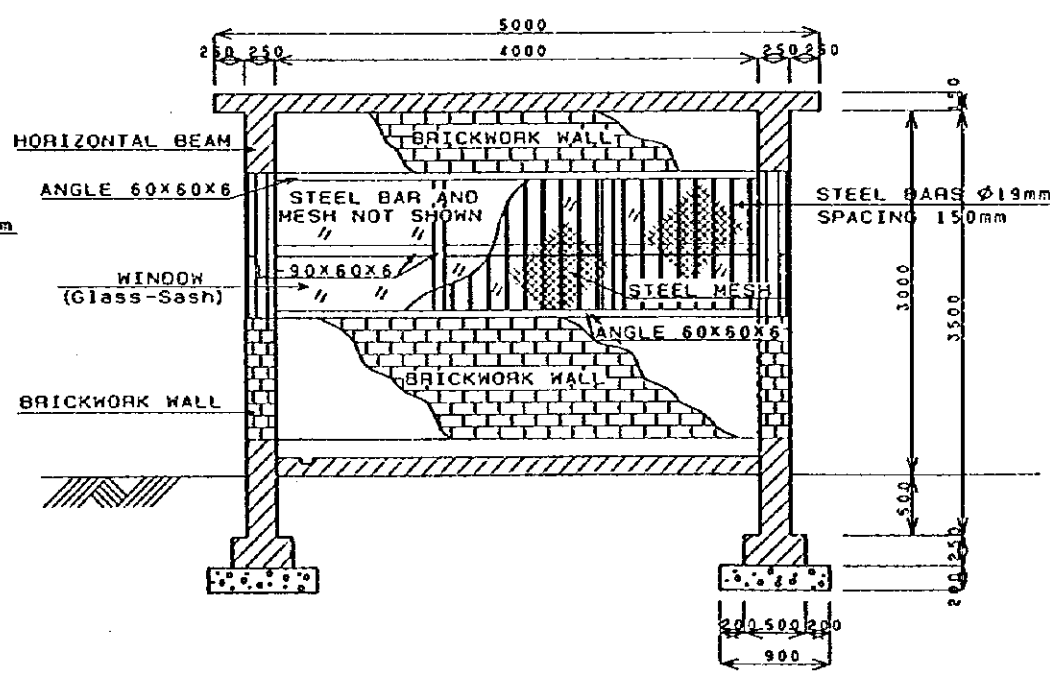

SECTION C-C

NOTES :

- (1) THIS DRAWING IS SHOWN A TYPICAL DRAWING FOR PUMP HOUSE TO USE ONE POINT LIFTING WATER AT BEGINNING OF MESKA.
- (2) THE PUMP HOUSE IS COMPOSED OF REINFORCING CONCRETE FOR FRAME WORK (BEAM, COLUMN AND FOUNDATION).
- (3) A WALL AND ROOF ARE MADE BY A BRICK WHILE A WINDOW IS MADE BY STEEL BARS AND MESH.
- (4) THE FOLLOWING WORKS ARE REFERRED THE HIS SPECIFICATIONS.
 - a) EARTH WORK OF FOUNDATION OF THE PUMP HOUSE WHILE CONCRETE WORK.
 - b) CONCRETE AND BRICK WORKS
 - c) STEEL WORK FOR THE REINFORCING BAR, WINDOW AND DOOR WORKS.

JAPAN INTERNATIONAL COOPERATION AGENCY (JICA)
 MINISTRY OF PUBLIC WORKS AND
 WATER RESOURCES (MPWWR)

THE MASTER PLAN STUDY FOR THE IMPROVEMENT OF IRRIGATION
 WATER MANAGEMENT AND ENVIRONMENT CONSERVATION IN
 NORTH-EAST REGION OF THE CENTRAL NILE DELTA

TYPICAL DRAWING FOR PUMP HOUSE

DATE MARCH, 1999 FIGURE NO. OD - 24

SANYU CONSULTANTS INC., JAPAN

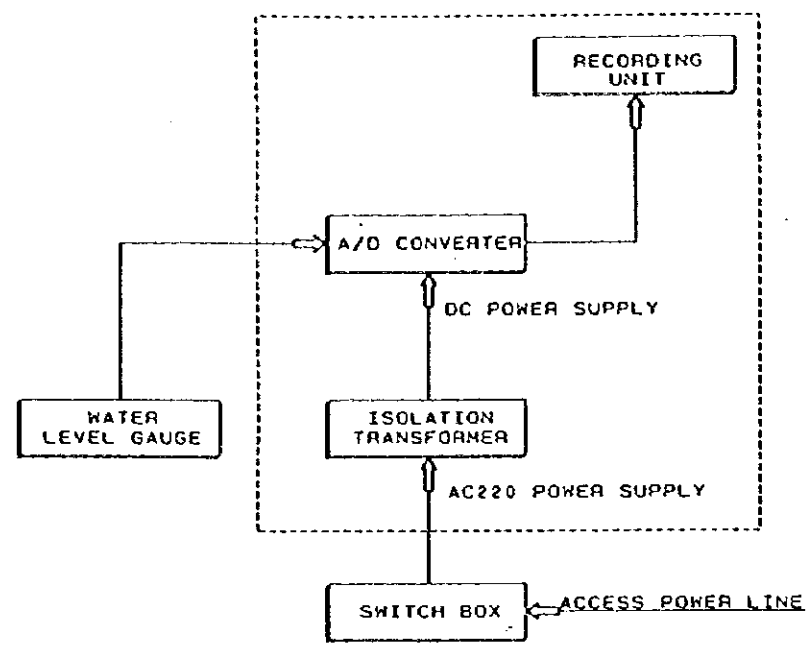

SYSTEM CONFIGURATION

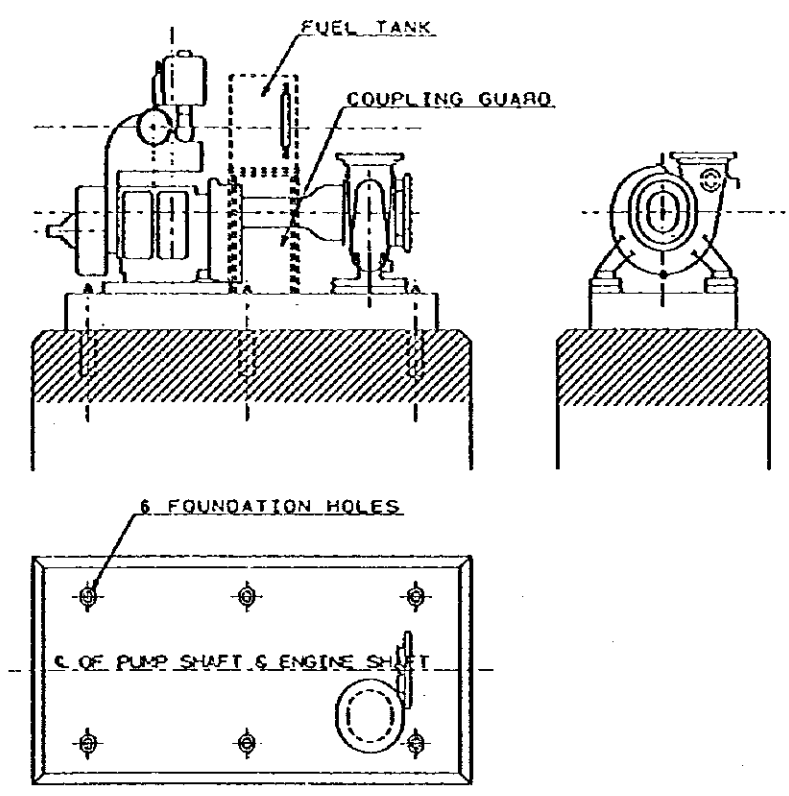

PUMP BASE

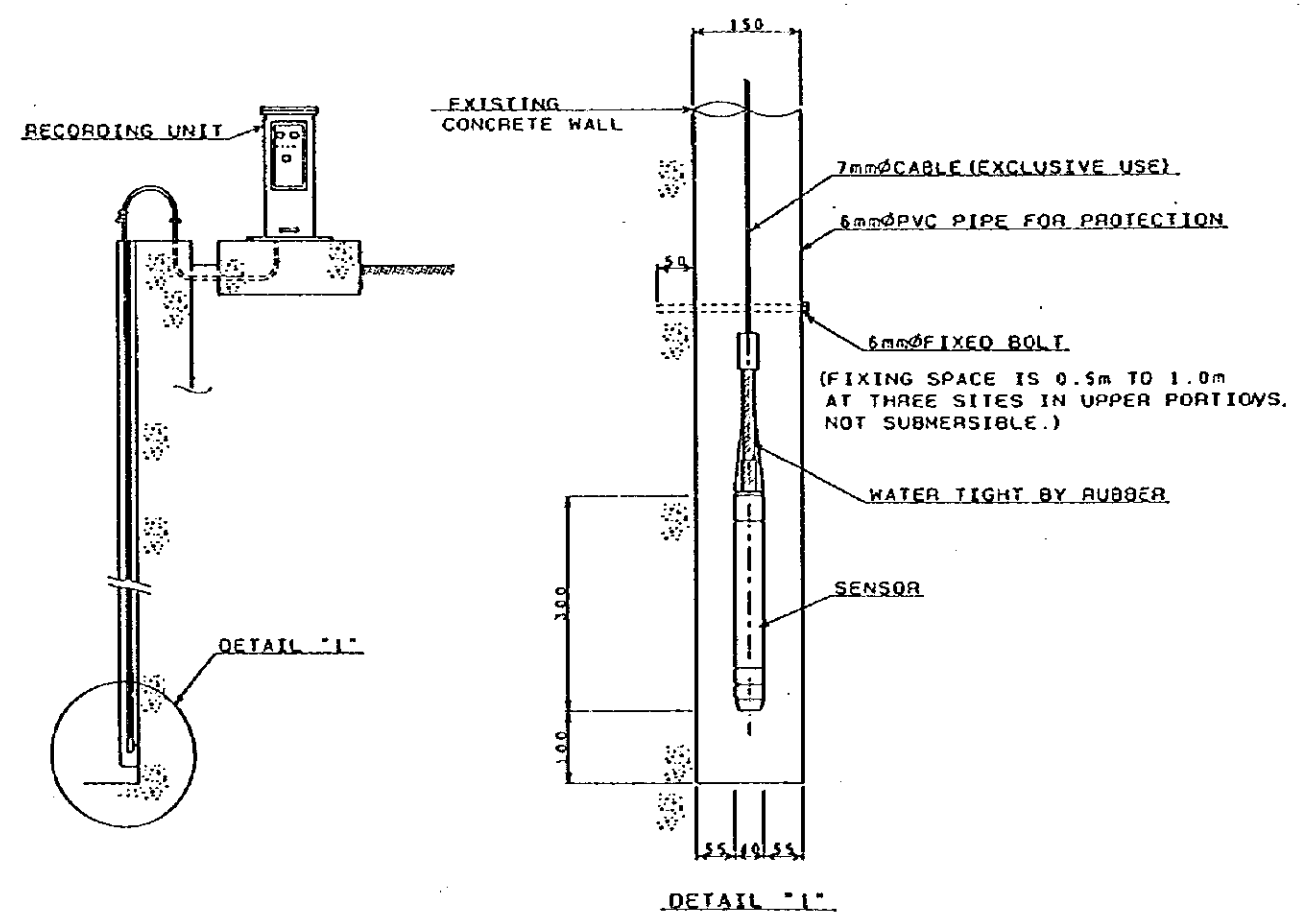

VERTICAL WATER LEVEL GAUGE

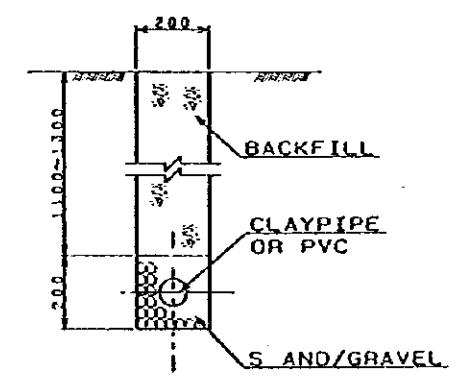

PIPE DRAINAGE

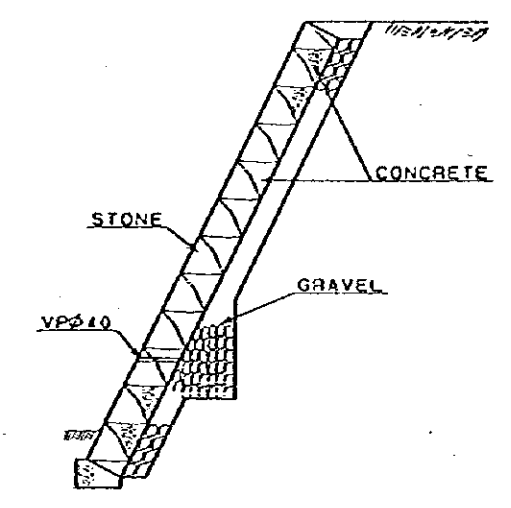

SLOPE PROTECTION (WET PITCHING)

- NOTES :
- (1) A VERTICAL WATER LEVEL GAUGE WILL BE INSTALLED AT FRONT AND BACK IN THE SUR INTAKE GATE IN THE CANAL.
 - (2) THIS WATER LEVEL METER WILL BE APPROVED BY THE IIS.
 - (3) THE FIXING PUMP BODY IS ON THE PUMP BASE RELATED TO THE PUMP FIXING LOCATION AS PER THE SHOP DRAWING.
 - (4) A PIPE DRAINAGE WORK IS SHOWN BY A TYPICAL STANDARD, SHOWN A CLAY PIPE, PVC AND GRAVELS AT THE BOTTOM.
 - (5) SLOPE PROTECTION WORK IS SHOWN BY AN WET PITCHING FOR COLLAPSE LOCATION ALONG THE IRRIGATION CANAL NETWORK.

JAPAN INTERNATIONAL COOPERATION AGENCY (JICA)
 MINISTRY OF PUBLIC WORKS AND
 WATER RESOURCES (MPWWR)

THE MASTER PLAN STUDY FOR THE IMPROVEMENT OF IRRIGATION
 WATER MANAGEMENT AND ENVIRONMENT CONSERVATION IN
 NORTH-EAST REGION OF THE CENTRAL NILE DELTA

MISCELLANEOUS

DATE	MARCH 1999	FIGURE NO.	00-25
SANYU CONSULTANTS INC., JAPAN			

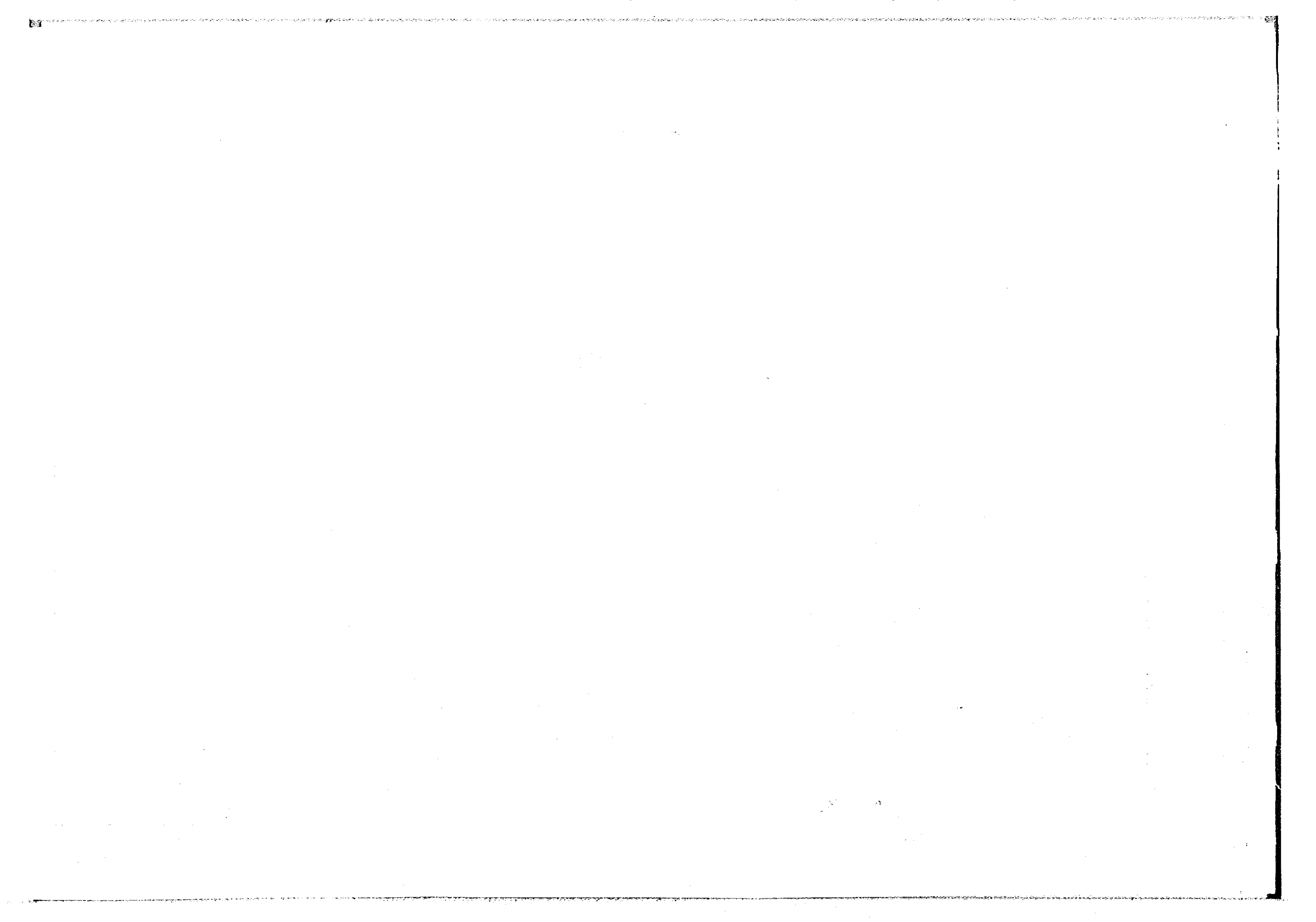

JICA