

PACIFIC CONSULTANTS INTERNATIONAL (P.C.I.) (PACIFIC CONSULTANTS INTERNATIONAL)
GENERAL OFFICE (HANOI)
111, LE HOA TACH STREET, HANOI, VIETNAM

THE FEASIBILITY STUDY
ON
THANH TRI BRIDGE AND
THE SOUTHERN SECTION
OF RING ROAD NO.3 IN HANOI
IN
THE SOCIALIST REPUBLIC OF VIETNAM

FINAL REPORT

VOLUME IV: DRAWINGS

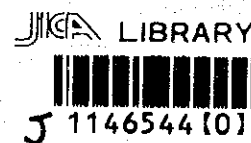

September 1998

PACIFIC CONSULTANTS INTERNATIONAL

SSF

98-106

JAPAN INTERNATIONAL COOPERATION AGENCY(JICA)
MINISTRY OF TRANSPORT
THE SOCIALIST REPUBLIC OF VIETNAM

THE FEASIBILITY STUDY
ON
THANH TRI BRIDGE AND
THE SOUTHERN SECTION
OF RING ROAD NO.3 IN HANOI
IN
THE SOCIALIST REPUBLIC OF VIETNAM

FINAL REPORT
VOLUME IV: DRAWINGS

September 1998

PACIFIC CONSULTANTS INTERNATIONAL



1146544 (0)

LIST OF DRAWINGS

A. Highway

Sheet Contents	Drw. No.
1 Location Map-----	1
2 Typical Cross Section (1) - (3)-----	2 - 4
3 Plan and Profile (1) - (9)-----	5 - 13
4 Plan NH-1 Interchange-----	14
5 Profile NH-1 Interchange (A) Ramp)-----	15
6 Profile NH-1 Interchange (B) Ramp)-----	16
7 Profile NH-1 Interchange (C) Ramp)-----	17
8 Profile NH-1 Interchange (D) Ramp)-----	18
9 Plan New NH-1 Interchange-----	19
10 Profile New NH-1 Interchange (A) Ramp)-----	20
11 Profile New NH-1 Interchange (B) Ramp)-----	21
12 Profile New NH-1 Interchange (C) Ramp)-----	22
13 Profile New NH-1 Interchange (D) Ramp)-----	23
14 Plan NH-5 Interchange-----	24
15 Profile NH-5 Interchange (A) Ramp)-----	25
16 Profile NH-5 Interchange (B) Ramp)-----	26
17 Profile NH-5 Interchange (C) Ramp)-----	27
18 Profile NH-5 Interchange (D) Ramp)-----	28
19 Plan Dyke Road Access (Hanoi)-----	29
20 Profile Dyke Road Access (Hanoi)-----	30
21 Plan Dyke Road Access (Gia Lam)-----	31
22 Profile Dyke Road Access (Gia Lam)-----	32

B. Structure

Sheet Contents	Drw. No.
23 General View-----	33
24 Main Bridge Superstructure-----	34
25 Main Bridge Substructure/Foundation-----	35
26 Approach Bridge-1 Hanoi-Side Superstructure-----	36
27 Approach Bridge-1 Gia Lam-Side Superstructure-----	37
28 Approach Bridge-1 Substructure/Foundation-----	38
29 Dyke Bridge-1 Superstructure-----	39
30 Dyke Bridge-1 Substructure/Foundation-----	40
31 Dyke Bridge-2 Superstructure-----	41
32 Dyke Bridge-2 Substructure/Foundation-----	42
33 Approach Bridge-2 Hanoi-Side Superstructure-----	43
34 Approach Bridge-2 Gia Lam-Side Superstructure-----	44
35 Approach Bridge-2 Substructure/Foundation-----	45
36 National Highway No. 1 Superstructure-----	46
37 National Highway No. 5 Superstructure-----	47
38 National Highway No. 1 and No. 5 Substructure/Foundation-----	48
39 New National Highway No. 1 A-Ramp Superstructure-----	49
40 New National Highway No. 1 B-Ramp Superstructure-----	50
41 New National Highway No. 1 A and B-Ramp Substructure/Foundation-----	51
42 Flyover Bridge (STA. 12+285 - STA. 12+585) Superstructure-----	52
43 Flyover Bridge (STA. 12+285 - STA. 12+585) Substructure/Foundation-----	53
44 Abutment-----	54
45 Box Culvert-----	55

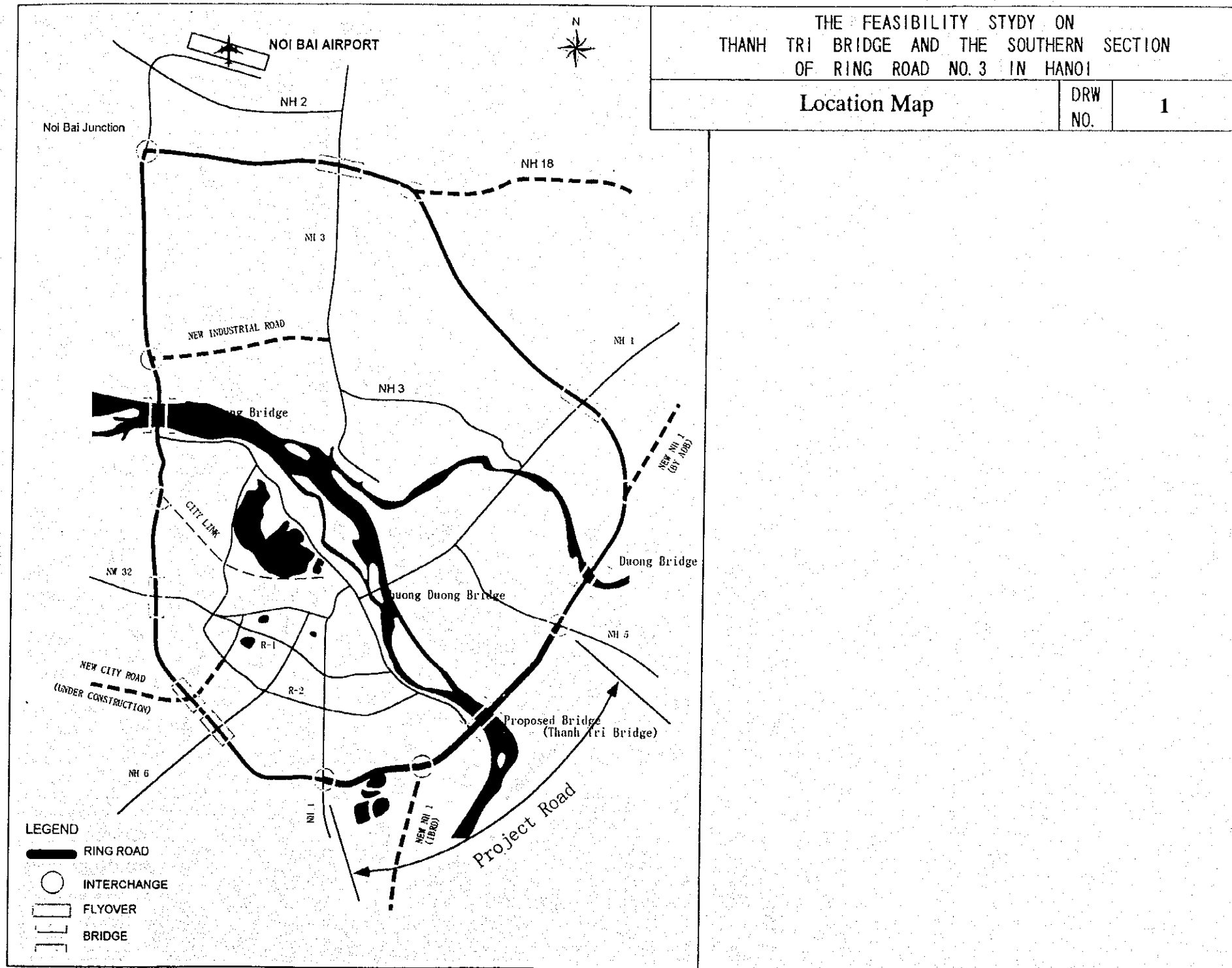

Location Map

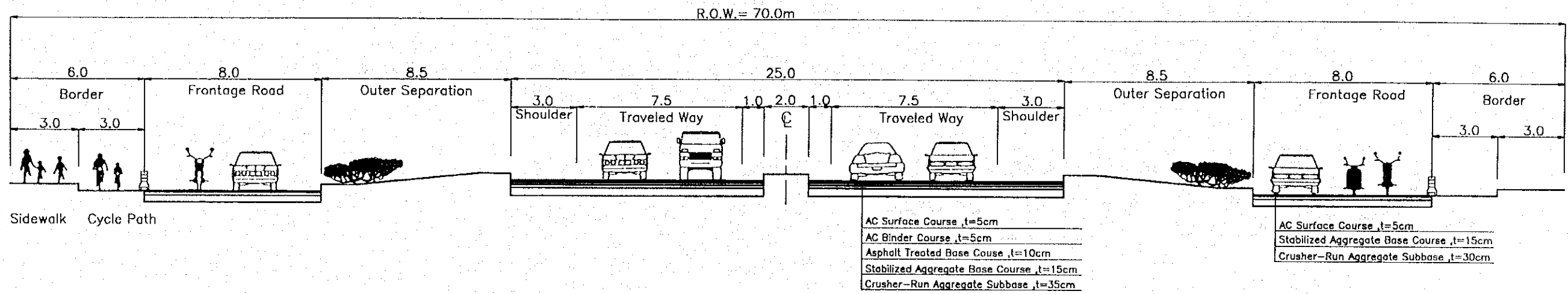

Through Traveled way with Frontage Road and Both Sides
 (Tyre D)

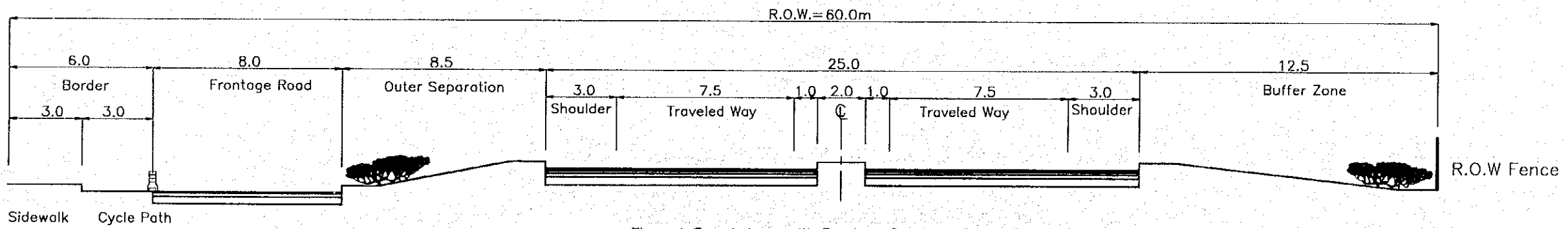

Through Traveled way with Frontage Road and Buffer Zone
 (Tyre C)

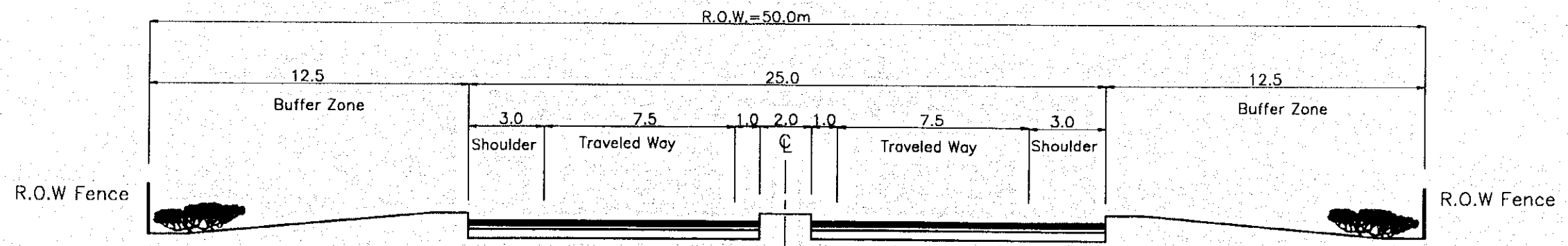

Through Traveled way with Buffer Zone
 (Tyre B)

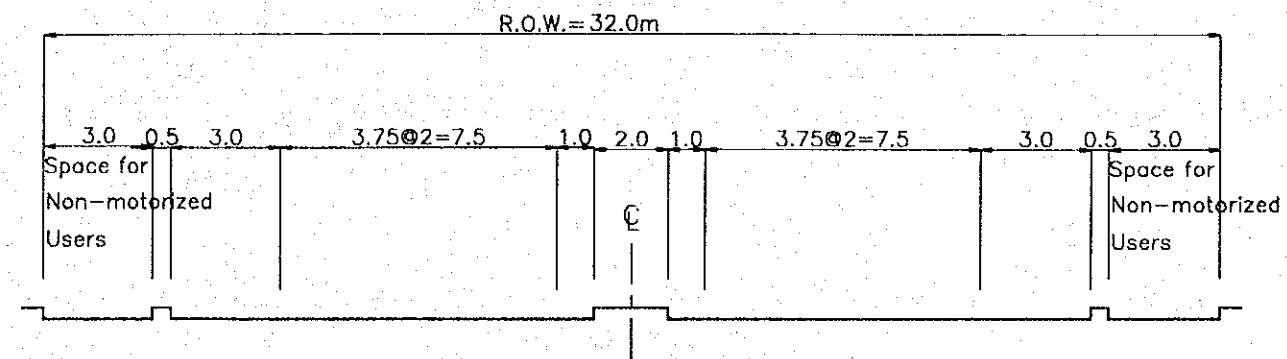

Typical Cross Section—Vehicular 4 Lanes Scheme

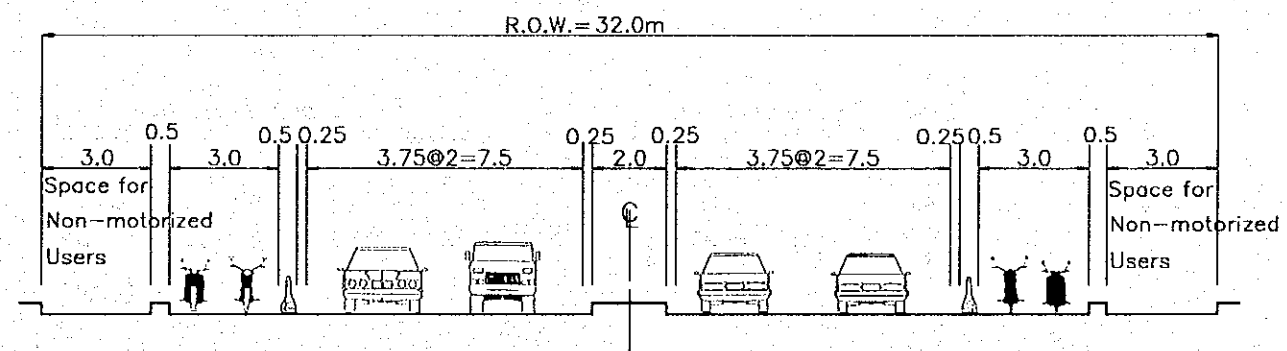

Typical Cross Section—Motorcycles Separation Scheme
 (Tyre A)

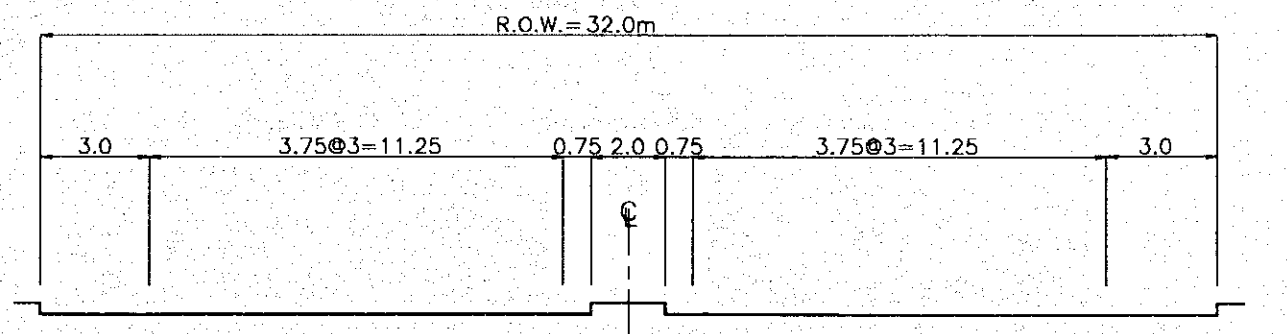

Typical Cross Section—Vehicular 6 Lanes Scheme

THE FEASIBILITY STUDY ON
 THANH TRI BRIDGE AND THE SOUTHERN SECTION
 OF RING ROAD NO.3 IN HANOI

Typical Cross Section (3)

DWG
 NO.

4

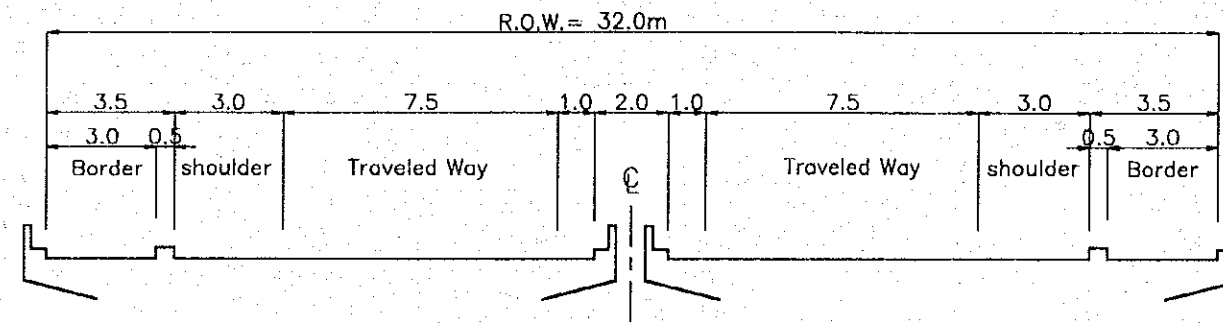

Through Traveled way on Thanh Tri Bridge

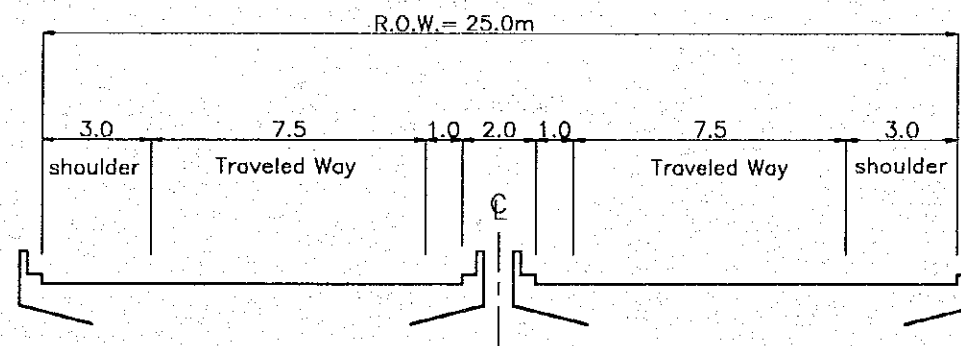

Through Traveled way on Bridges except Thanh Tri Bridge

THE FEASIBILITY STUDY ON
THANH TRI BRIDGE AND THE SOUTHERN SECTION
OF RING ROAD NO.3 IN HANOI

Plan and Profile (1)

DWG
No.

5

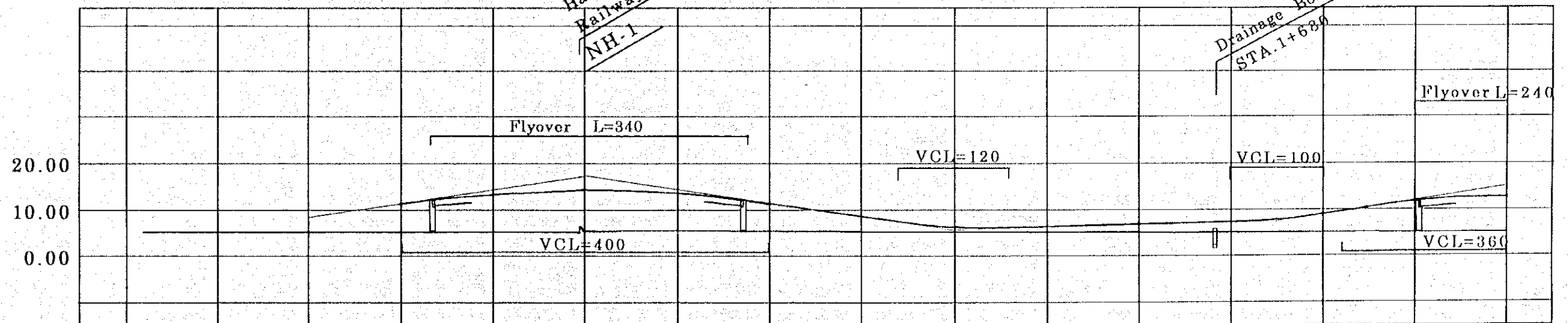
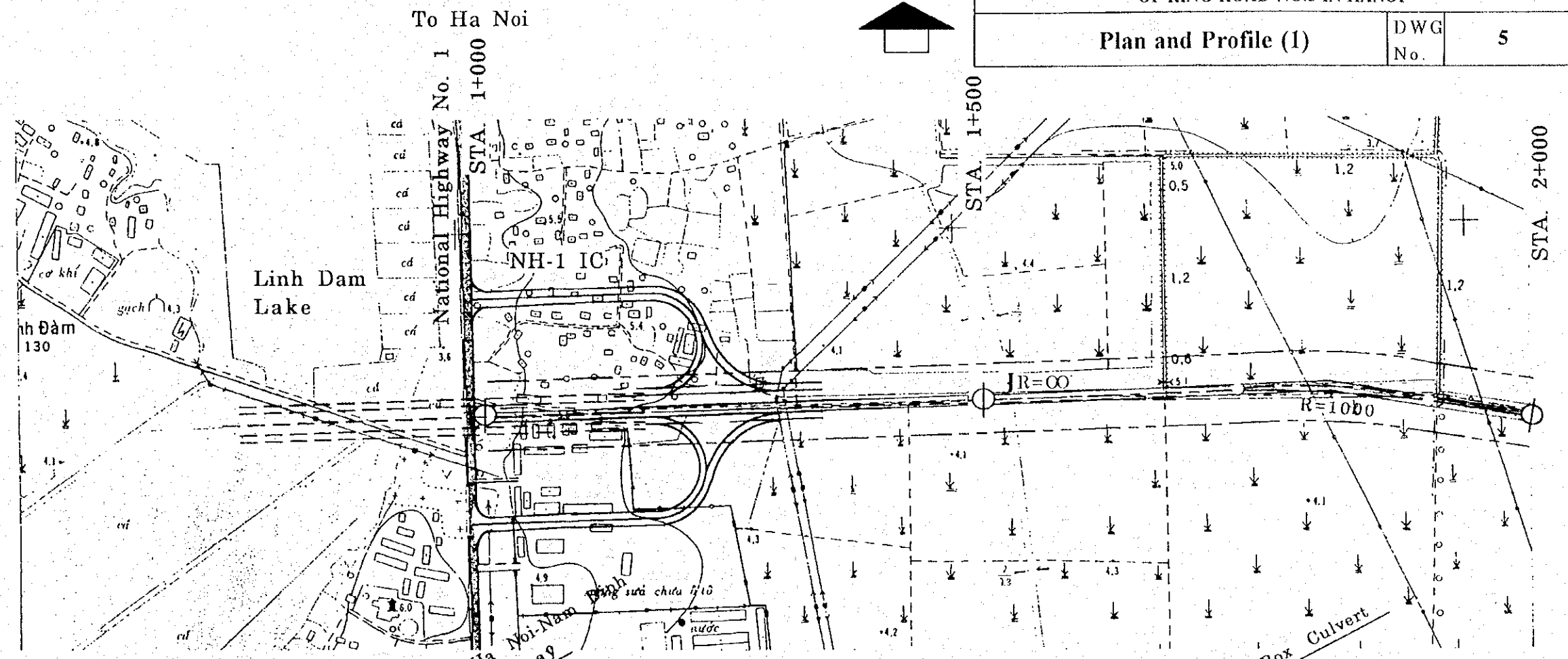

GRADE	GROUND LEVEL	STATION
3%		
17.5 1+000	6.63 5.78	1+000
3% L=400	5.89	
5.5 1+400	5.74	
0.6% L=350	5.57	
7.6 1+750	5.47	1+500
3% L=250	5.45	
15.1 2+000	5.37	
	5.35	
	5.34	
	5.30	
	5.36	2+000

THE FEASIBILITY STUDY ON
THANH TRI BRIDGE AND THE SOUTHERN SECTION
OF RING ROAD NO.3 IN HANOI

Plan and Profile (3)

DWG
No.

7

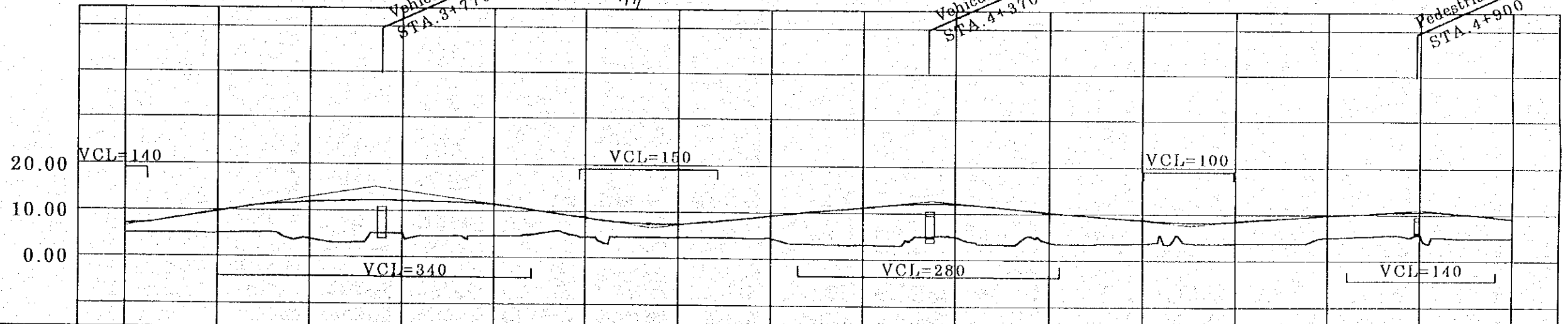
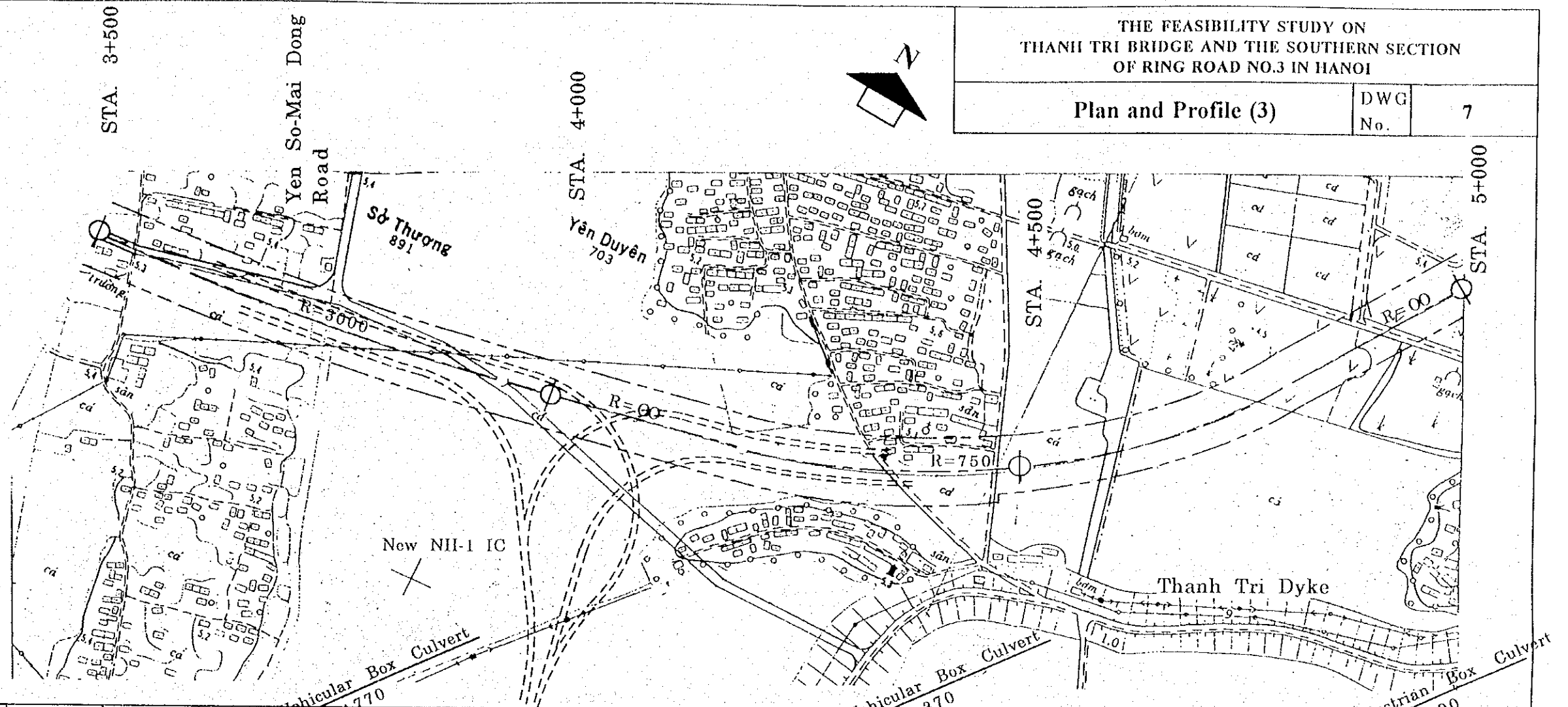

GRADE	2.7% L=320		14.0 3+770	2.5% L=300		6.6 4+070	2.2% L=300		13.2 4+370	2% L=280		7.6 4+650	1.2% L=250		10.6 4+900	1% L=400				
GROUND LEVEL	5.13	5.14	4.23	3.06	5.13	4.73	4.76	4.98	4.71	3.20	5.36	5.42	3.66	3.76	5.62	3.68	5.03	5.76	3.65	4.82
STATION	3+500			4+000						4+500						5+000				

THE FEASIBILITY STUDY ON
THANH TRI BRIDGE AND THE SOUTHERN SECTION
OF RING ROAD NO.3 IN HANOI

Plan and Profile (4)

DWG
No.

8

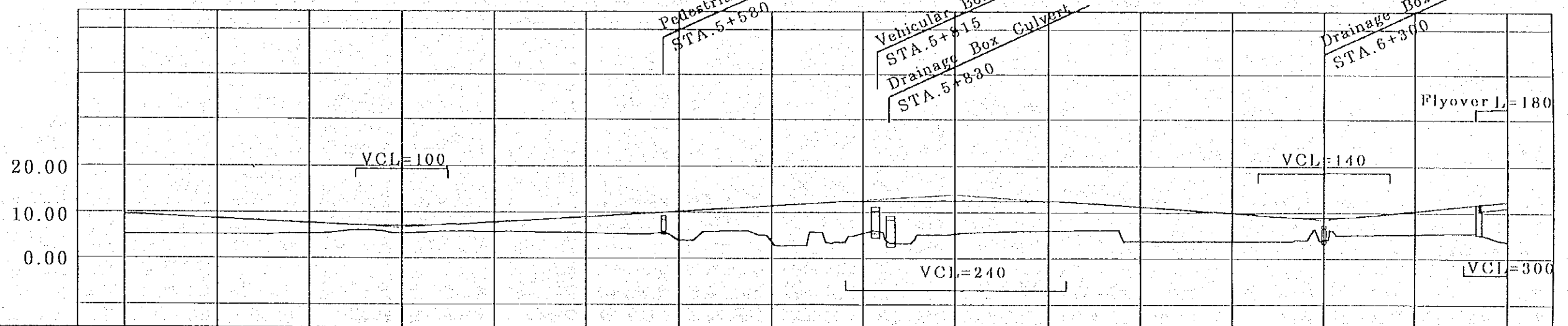
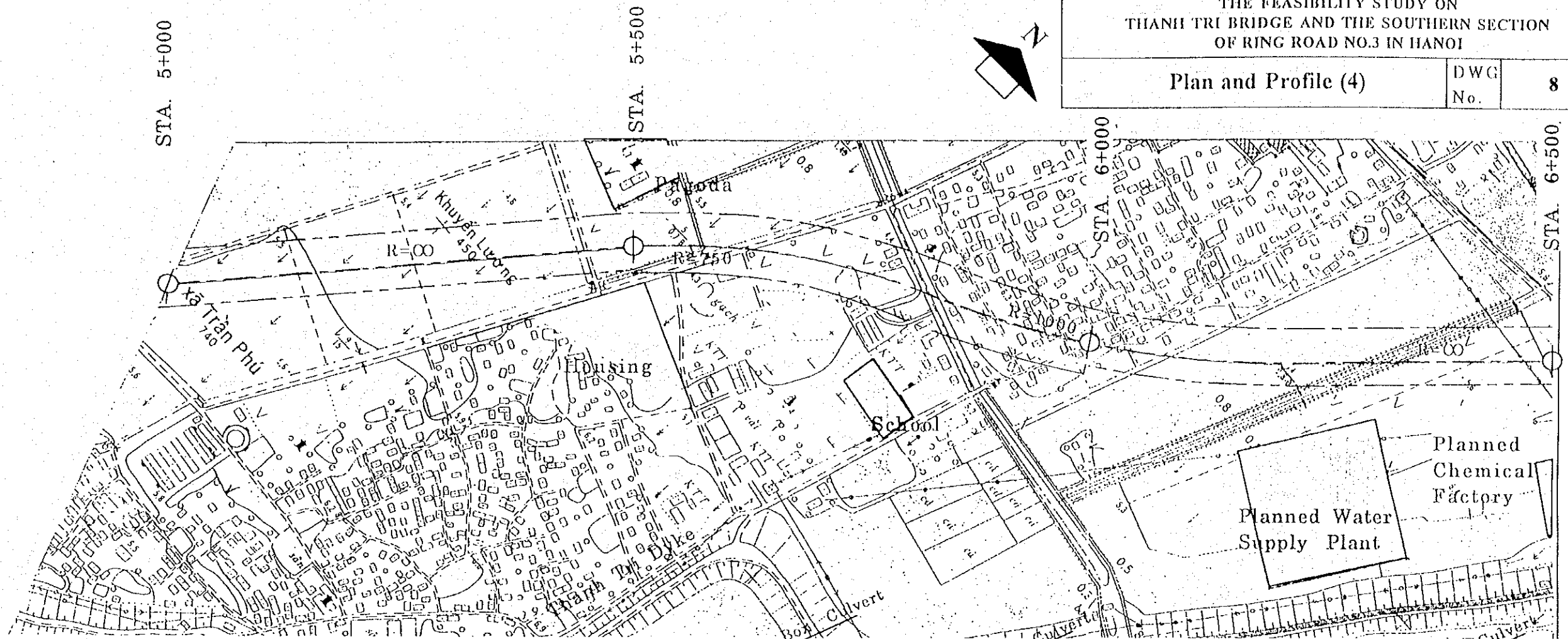

GRADE	1% L=400		6.6 5+300		1.2% L=600		13.8 5+900		1.4% L=400		8.4 6+300		2.0% L=250									
GROUND LEVEL	4.82	5.17	5.06	5.80	5.23	5.43	5.03	3.56	5.74	3.72	2.44	3.44	5.95	6.27	4.18	5.35	3.33	3.51	5.93	3.37	4.77	3.58
STATION	5+000			5+500						6+000						6+500						

THE FEASIBILITY STUDY ON
THANH TRI BRIDGE AND THE SOUTHERN SECTION
OF RING ROAD NO.3 IN HANOI

Plan and Profile (5)

DWG
NO.

9

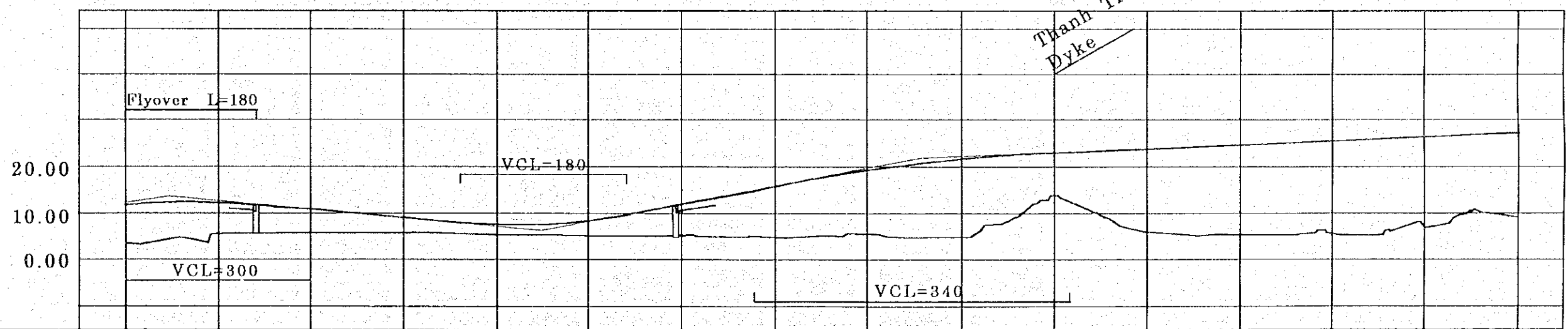
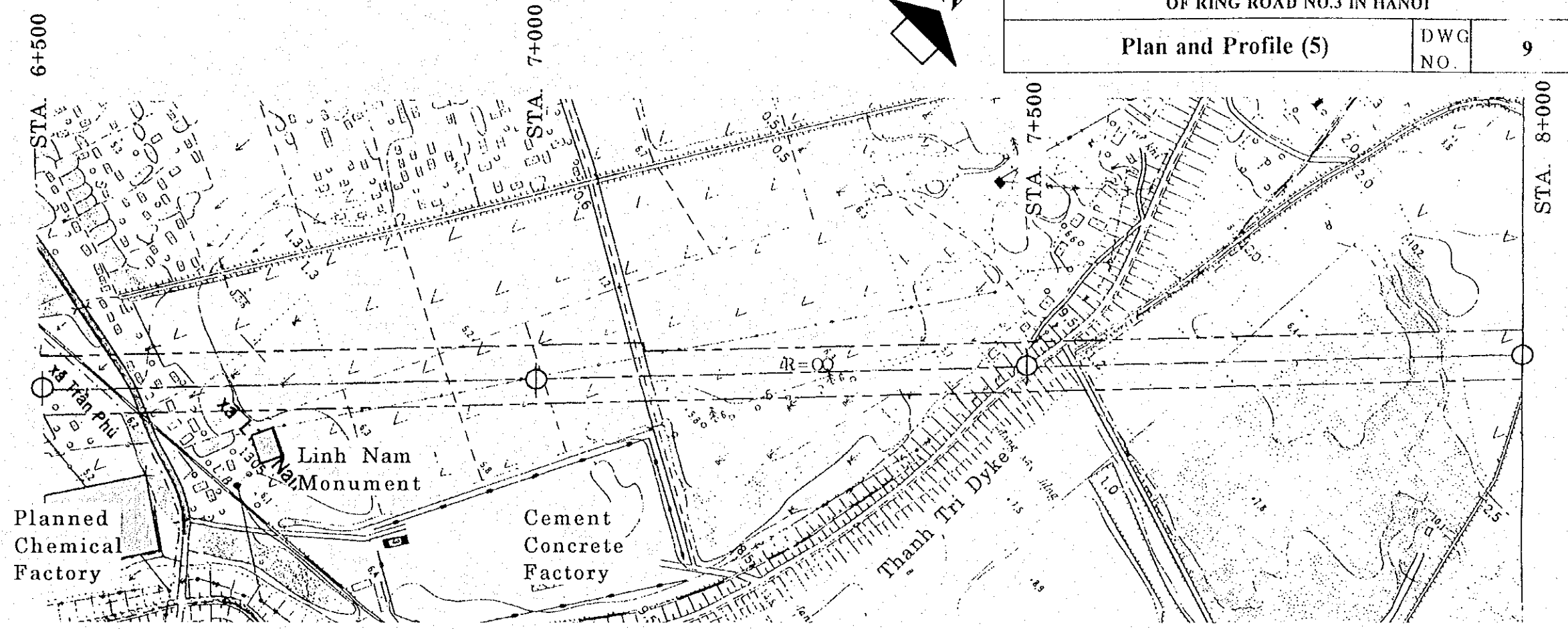

GRADE	13.2 6+550		1.7% L=400		6.2 6+950		4.0% L=410		22.6 7+360		0.72% L=1240					
GROUND LEVEL	8.58	6.38	6.15	5.92	5.70	5.57	5.50	5.02	5.68	4.77	14.06	6.02	5.31	5.33	6.99	9.53
STATION	6+500		7+000				7+500				8+000					

THE FEASIBILITY STUDY ON
THANH TRI BRIDGE AND THE SOUTHERN SECTION
OF RING ROAD NO.3 IN HANOI

Plan and Profile (6)

DWG
NO.

10

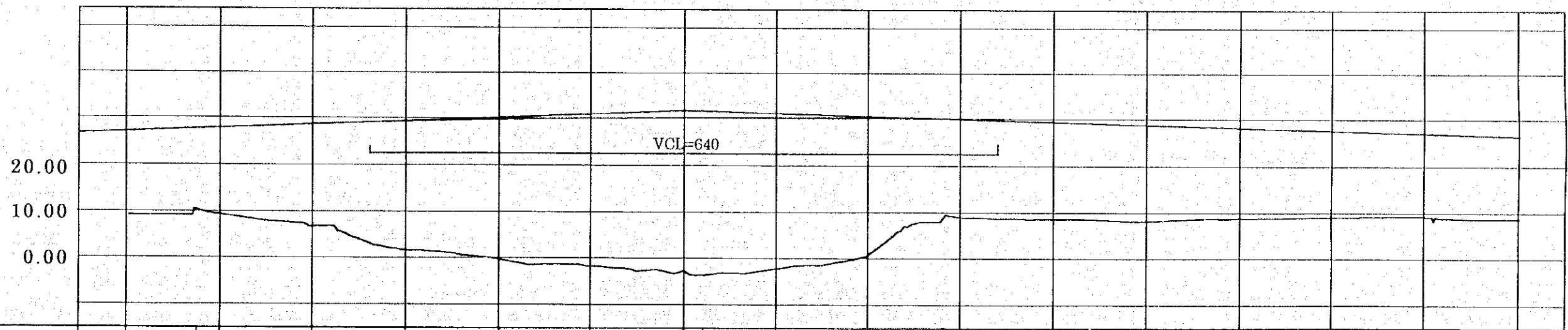
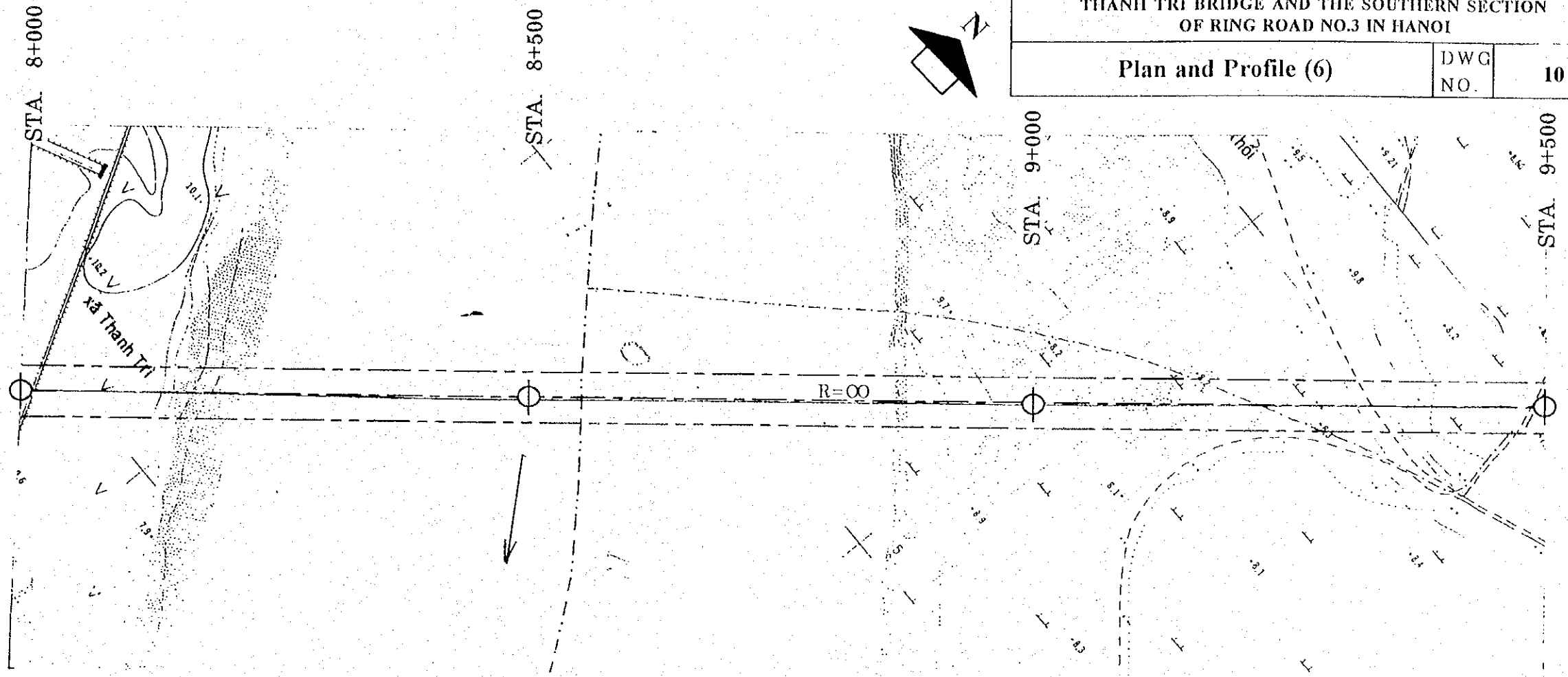

GRADE																			
GROUND LEVEL	9.53	10.65	9.63	6.79	1.95	0.08	-1.08	-2.80	-3.80	-2.73	-0.21	9.59	8.94	8.81	8.28	8.48	8.69	8.92	8.46
STATION	8+000						8+500					9+000							9+500

THE FEASIBILITY STUDY ON
THANH TRI BRIDGE AND THE SOUTHERN SECTION
OF RING ROAD NO.3 IN HANOI

Plan and Profile (8)

DWG
No.

12

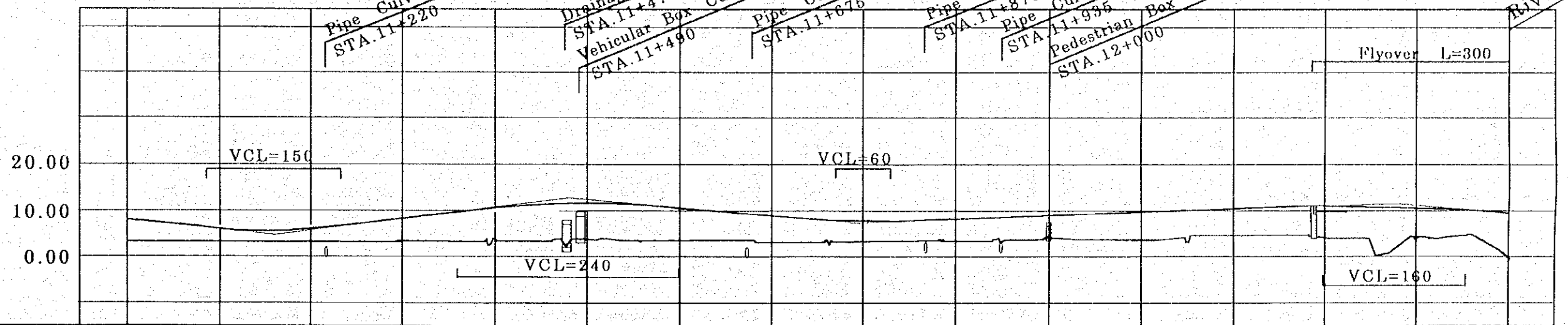
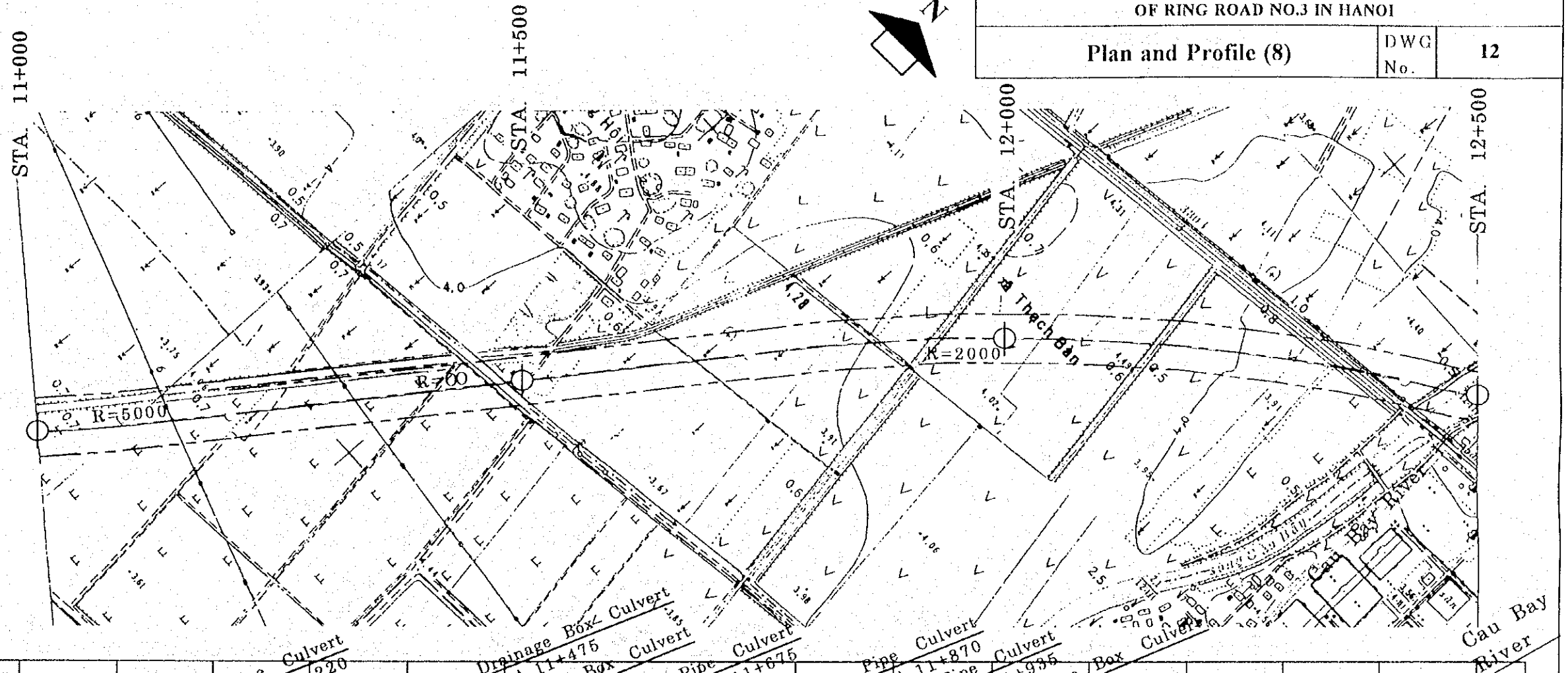

GRADE	GROUND LEVEL	STATION
2% L=300	3.57	11+000
4.8 11+160	3.55	
2.4% L=320	3.79	
12.5 11+480	3.78	
1.3% L=320	4.33	11+500
8.3 11+800	4.26	
0.6% L=580	3.90	
	3.57	
	3.72	12+000
	3.83	
	4.78	
	4.05	
	4.18	
	4.13	
11.7 12+380	2.24	
2.6% L=360	5.17	
	5.04	12+500
	1.20	

THE FEASIBILITY STUDY ON
THANH TRI BRIDGE AND THE SOUTHERN SECTION
OF RING ROAD NO.3 IN HANOI

Plan and Profile (9)

DWG
No.

13

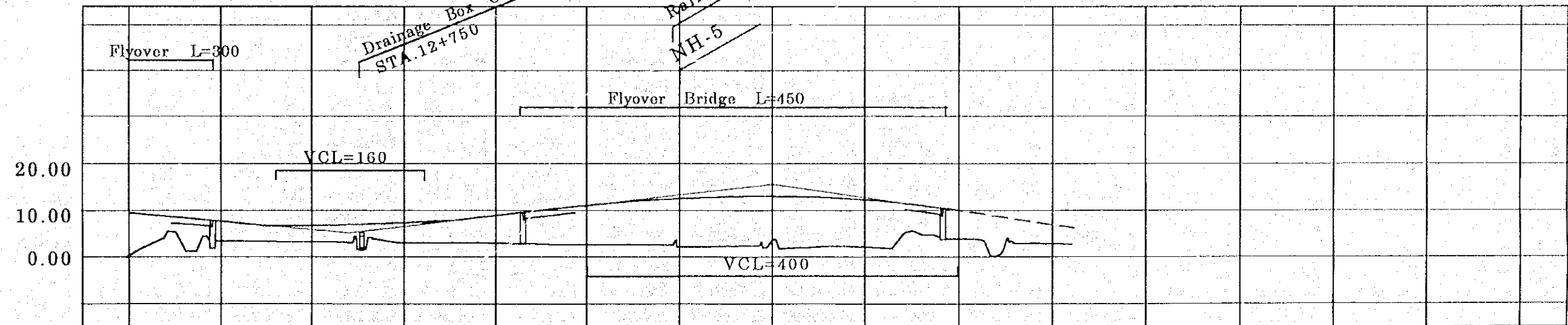
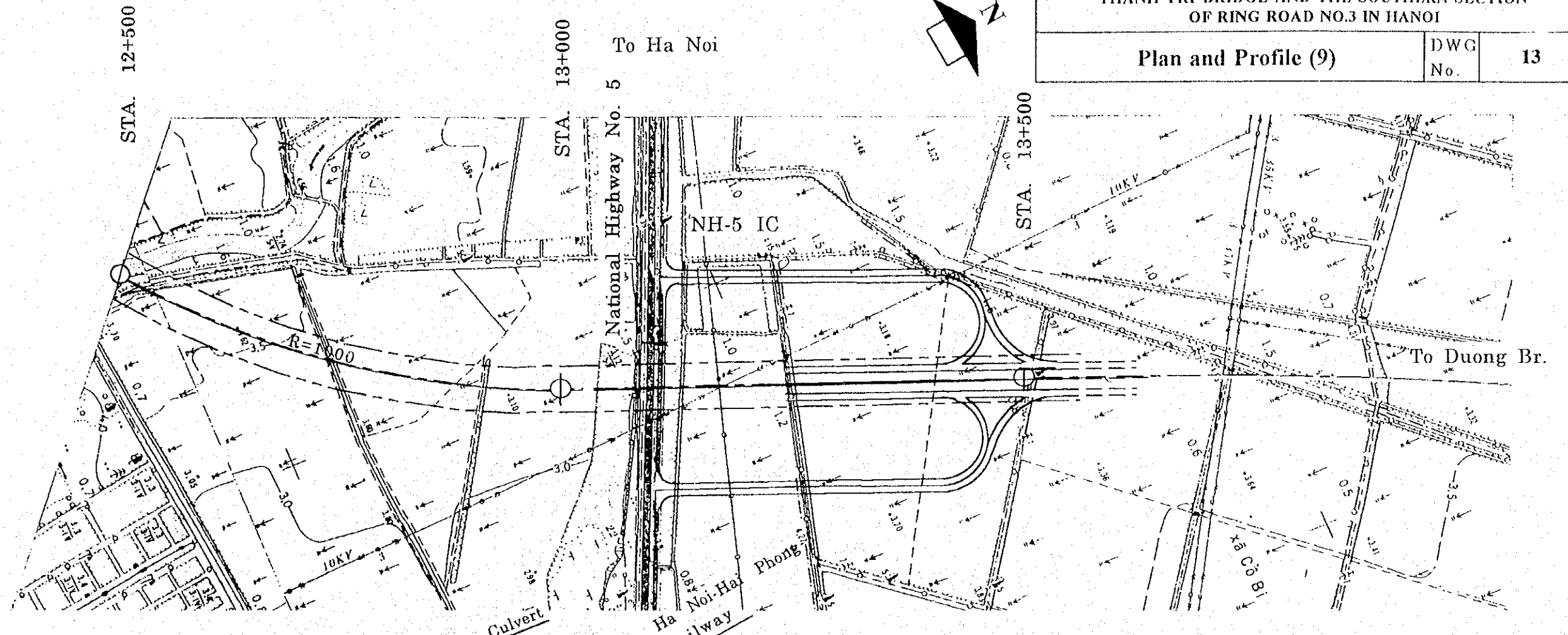

GRADE																		
GROUND LEVEL	1.20	5.15	2.10	3.54	3.35	4.05	2.16	3.12	3.13	3.19	3.77	2.74	3.92	2.78	5.20	4.04	1.25	3.20
STATION	12+500				13+000				13+500									

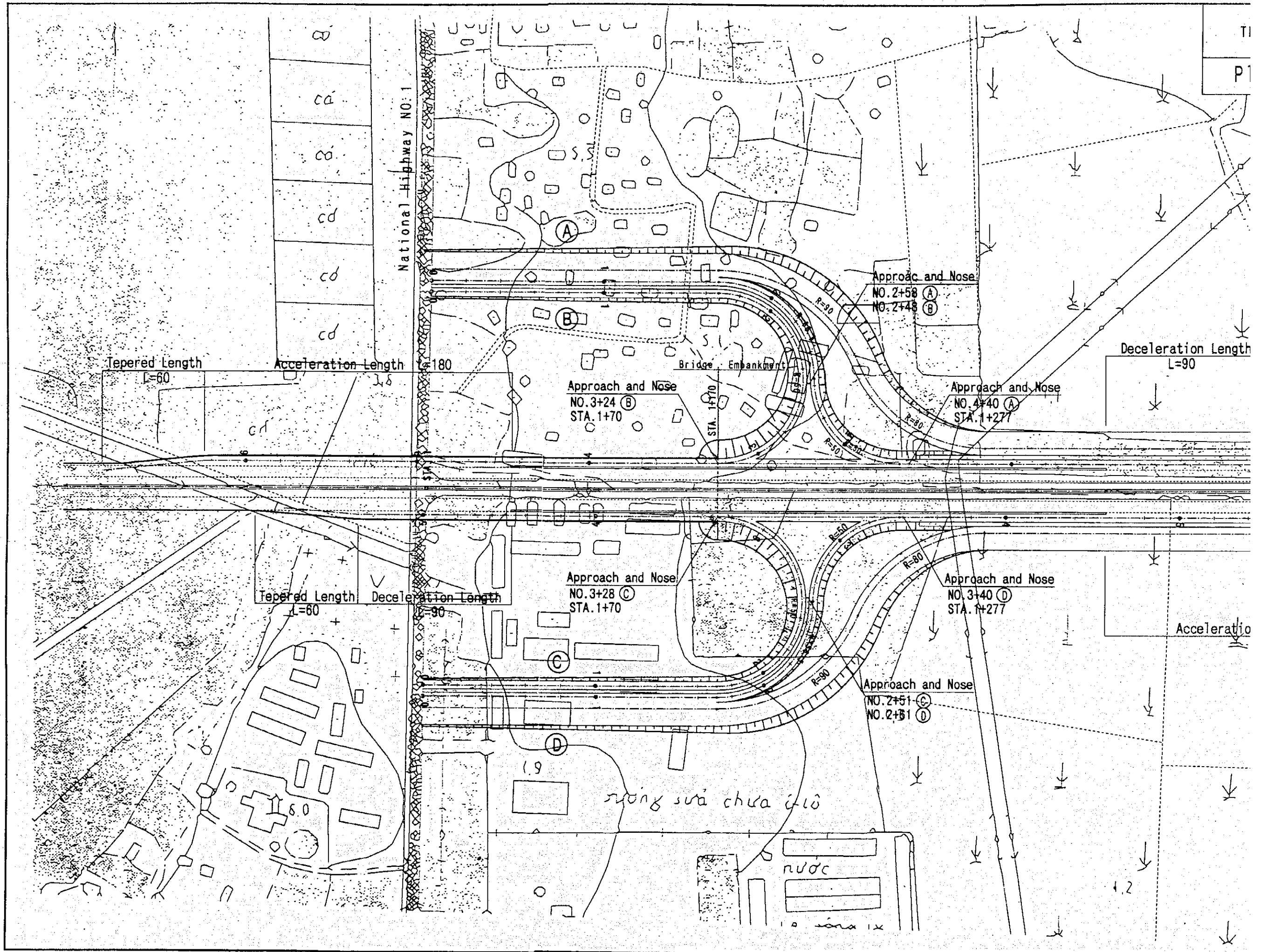

THE FEASIBILITY STUDY ON
THANH TRI BRIDGE AND THE SOUTHERN SECTION
OF RING ROAD NO. 3 IN HANOI

Plan NH-1 Interchange DWG NO. 14

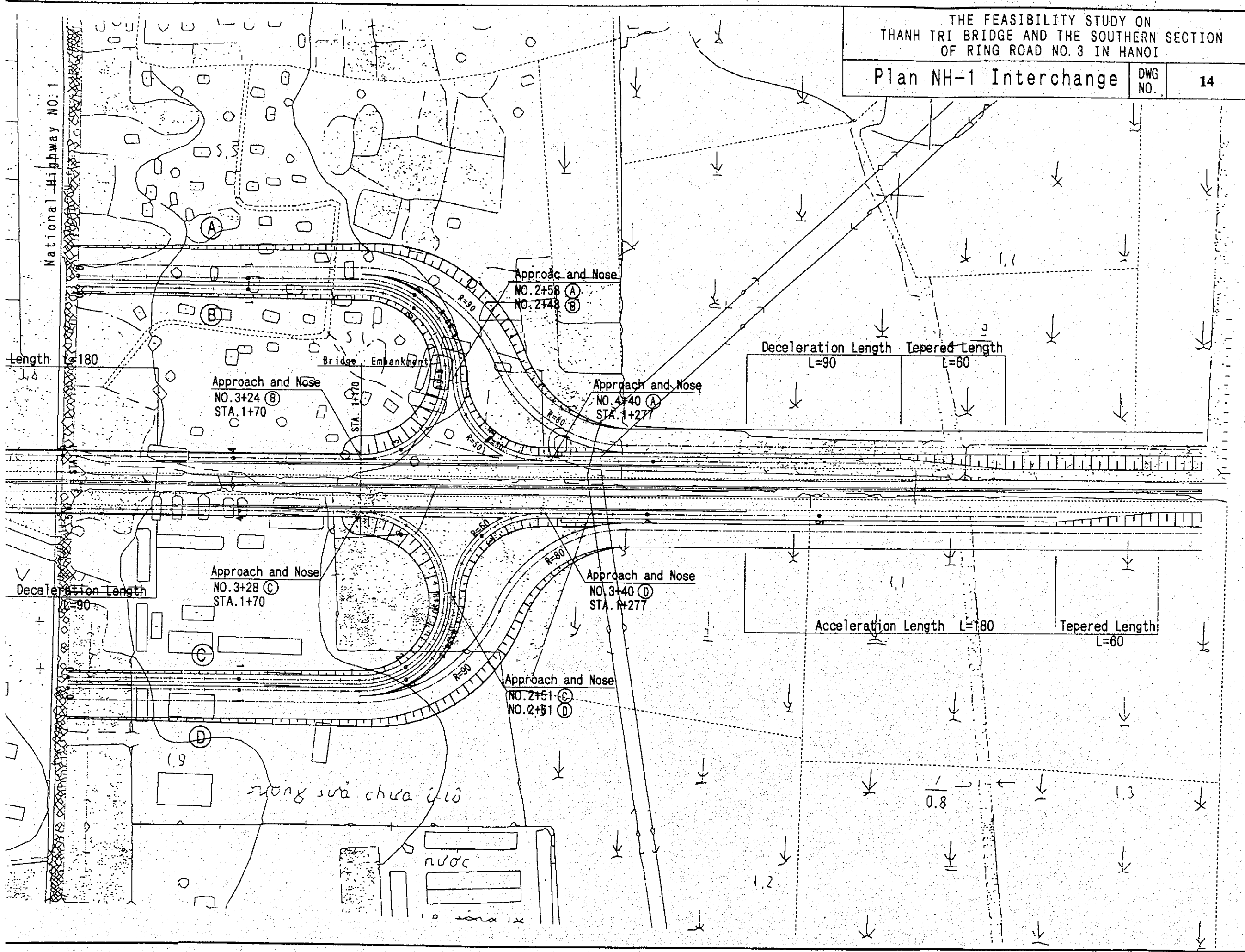

THE FEASIBILITY STUDY ON
THANH TRI BRIDGE AND THE SOUTHERN SECTION
OF RING ROAD NO. 3 IN HANOI

Profile NH-1 Interchange (A) Ramp

DWG
NO.

15

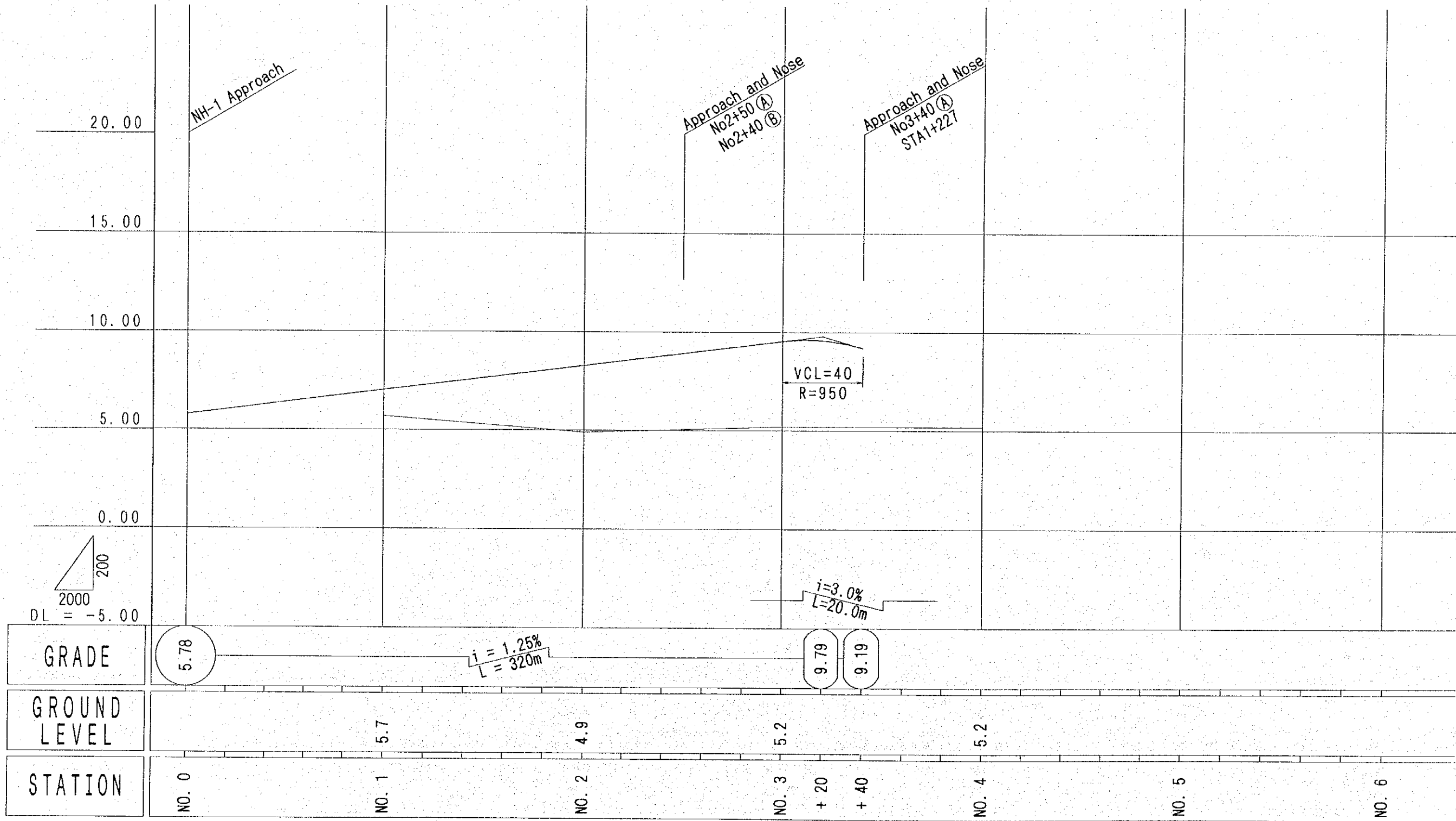

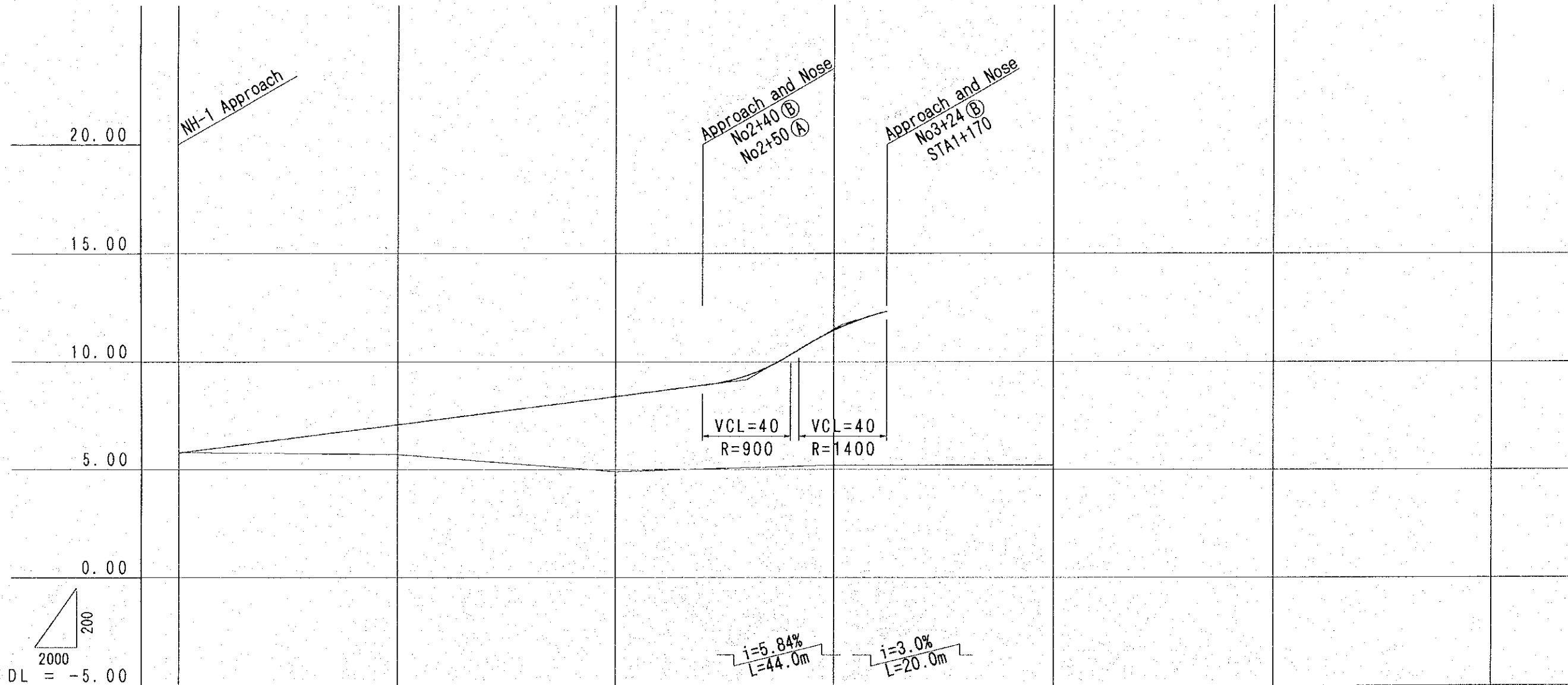

GRADE	5.78	$i = 1.30\%$ $L = 260m$	9.16	11.73	12.33				
GROUND LEVEL	5.8	5.7	4.9	5.2	5.2				
STATION	NO. 0	NO. 1	NO. 2	+ 60	NO. 3 + 4	+ 24	NO. 4	NO. 5	NO. 6

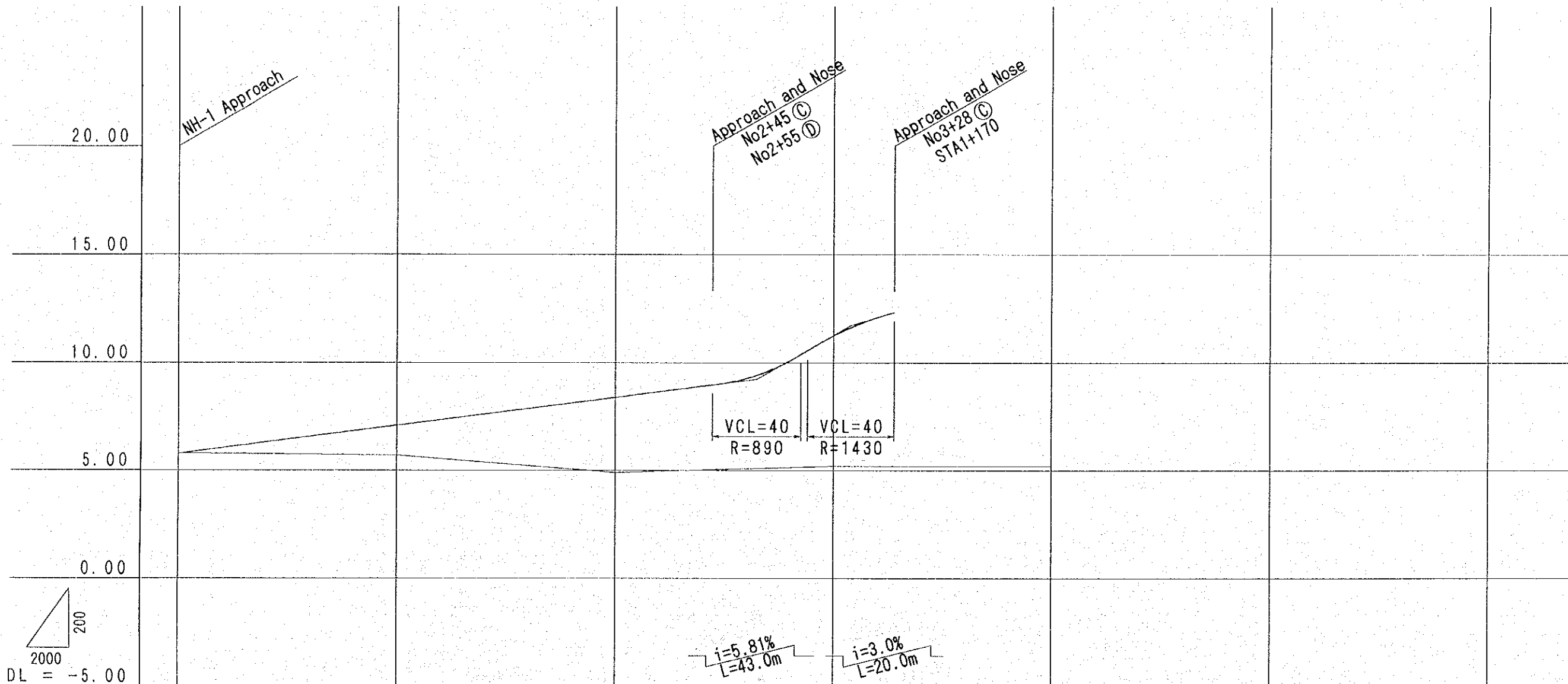

GRADE	5.78	$i = 1.30\%$ $L = 271m$		9.23	11.73	12.33				
GROUND LEVEL	5.8	5.7		4.9		5.2		5.2		
STATION	NO. 0	NO. 1		NO. 2	+ 65	NO. 3 + 8 + 28		NO. 4	NO. 5	NO. 6

THE FEASIBILITY STUDY ON
 THANH TRI BRIDGE AND THE SOUTHERN SECTION
 OF RING ROAD NO. 3 IN HANOI

Profile NH-1 Interchange((D)Ramp)

DWG
 NO.

18

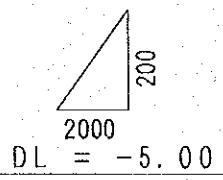
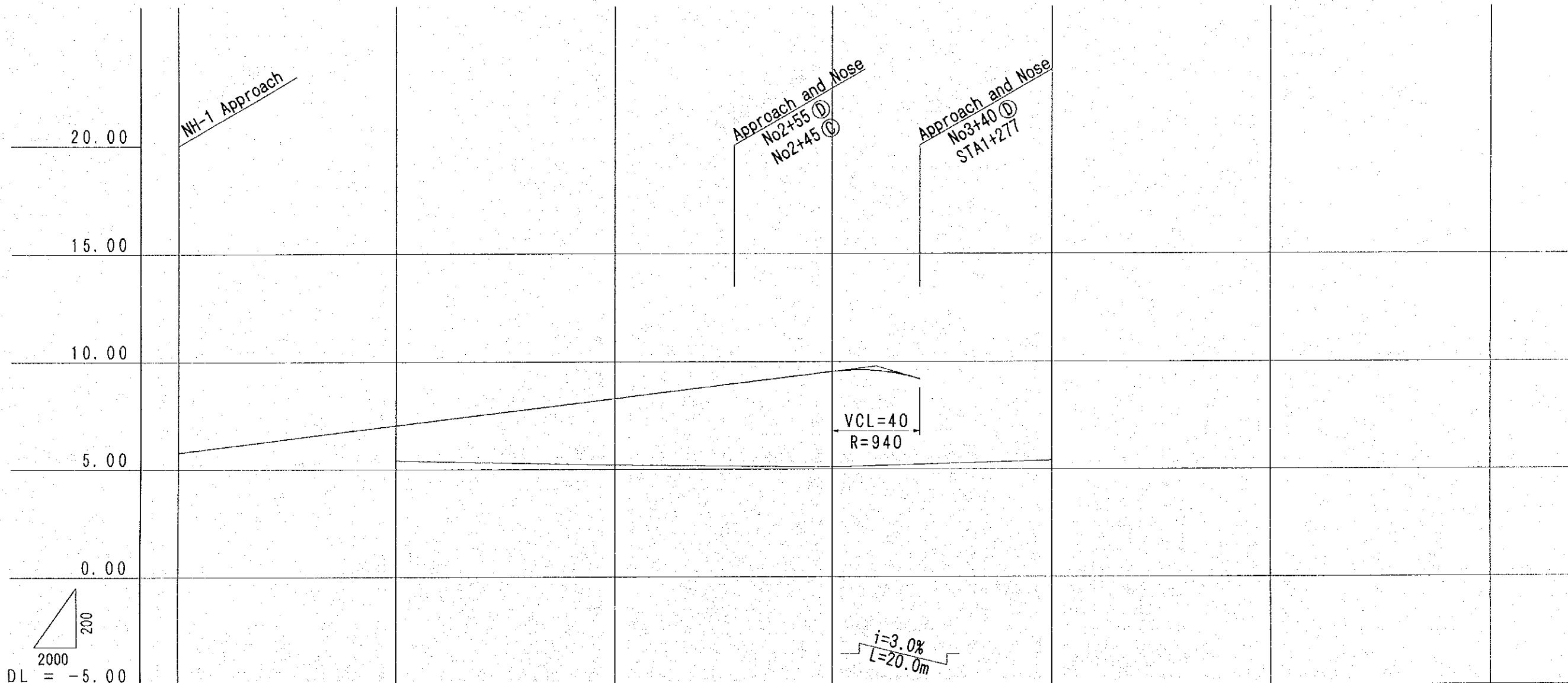

GRADE	5.78	$i = 1.25\%$ $L = 320m$		9.79	9.19			
GROUND LEVEL		5.4	5.2	5.1	5.4			
STATION	NO. 0	NO. 1	NO. 2	NO. 3 + 20 + 40	NO. 4	NO. 5		NO. 6

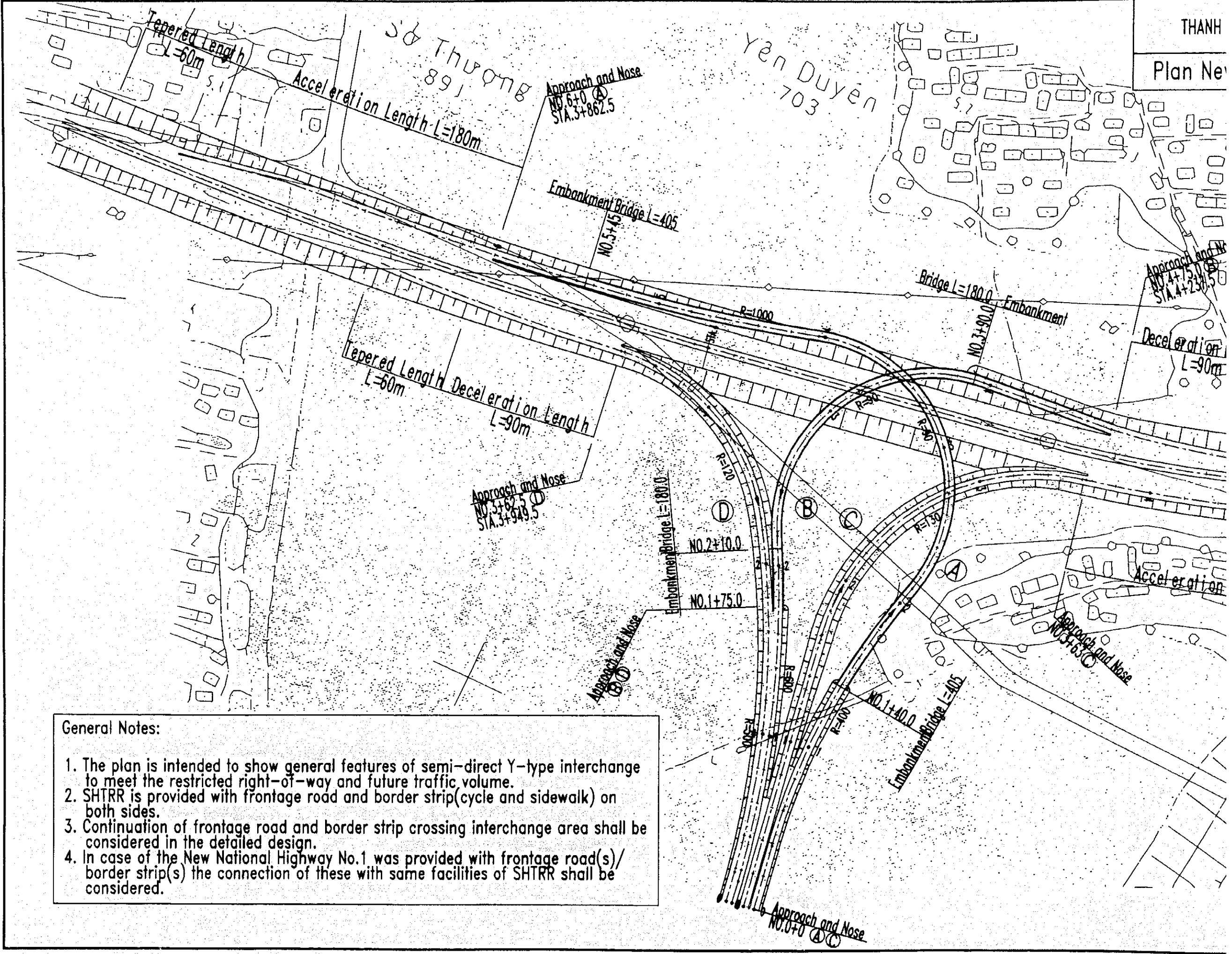

- General Notes:**
1. The plan is intended to show general features of semi-direct Y-type interchange to meet the restricted right-of-way and future traffic volume.
 2. SHTRR is provided with frontage road and border strip (cycle and sidewalk) on both sides.
 3. Continuation of frontage road and border strip crossing interchange area shall be considered in the detailed design.
 4. In case of the New National Highway No.1 was provided with frontage road(s)/border strip(s) the connection of these with same facilities of SHTRR shall be considered.

THE FEASIBILITY STUDY ON
THANH TRI BRIDGE AND THE SOUTHERN SECTION
OF RING ROAD NO.3 IN HANOI

Plan New NH-1 Interchange

DWG
NO.

19

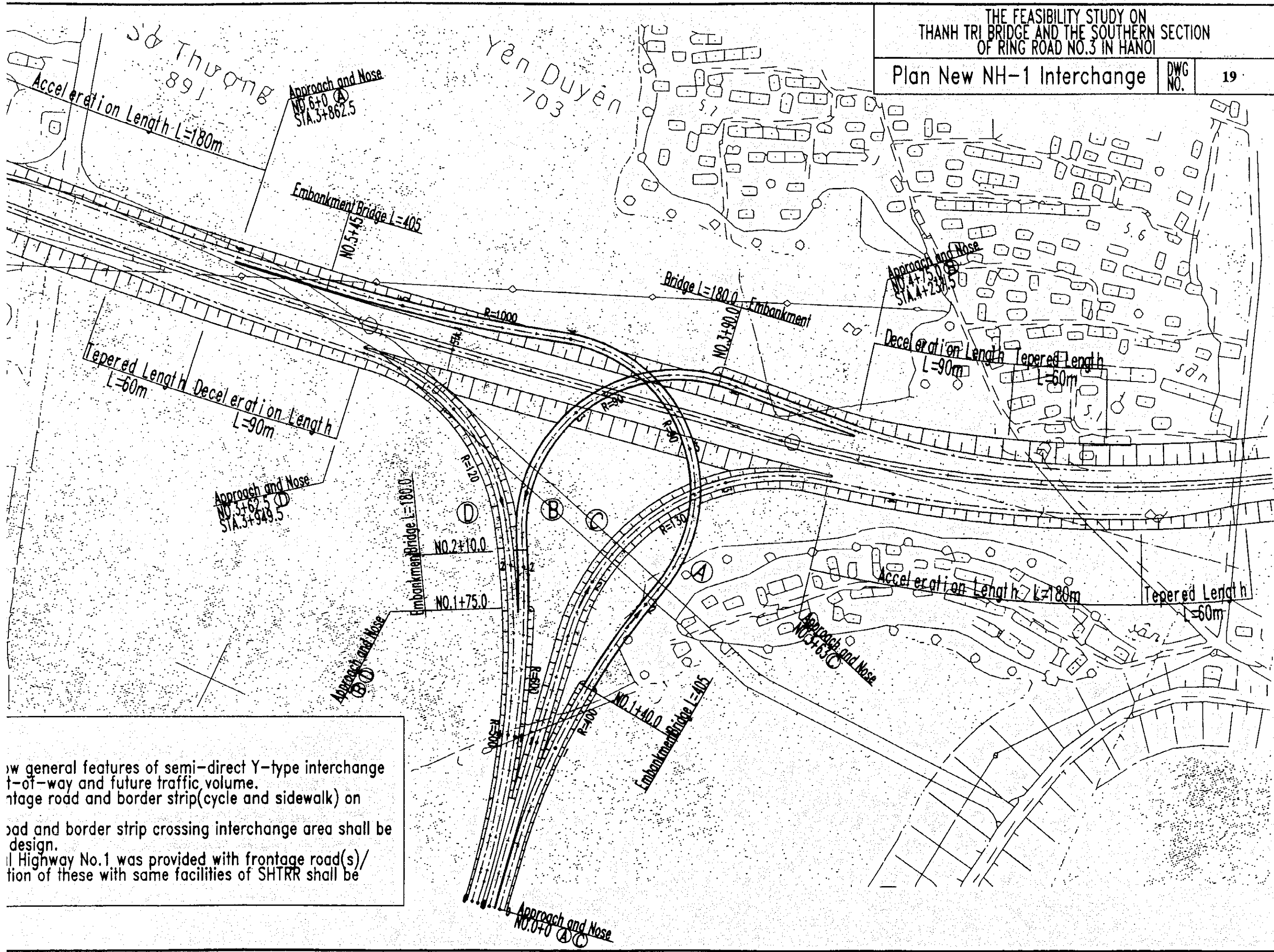

show general features of semi-direct Y-type interchange
t-of-way and future traffic volume.
ntage road and border strip(cycle and sidewalk) on
oad and border strip crossing interchange area shall be
design.
il Highway No.1 was provided with frontage road(s)/
tion of these with same facilities of SHTRR shall be

THE FEASIBILITY STUDY ON
THANH TRI BRIDGE AND THE SOUTHERN SECTION
OF RING ROAD NO. 3 IN HANOI

Profile New NH-1 Interchange (A Ramp)

DWG
NO.

20

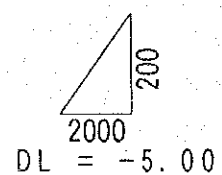
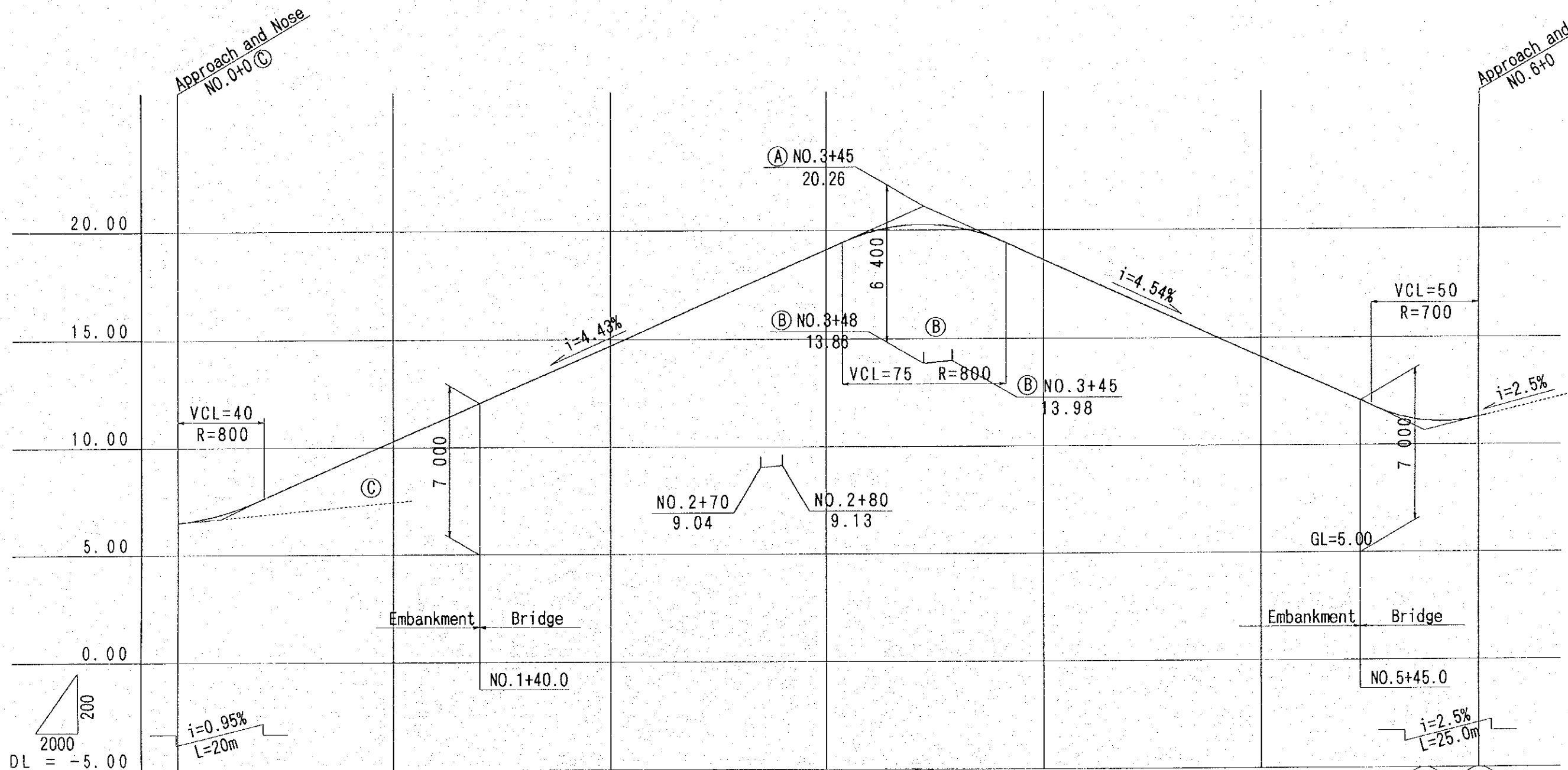

GRADE	6.50	6.69				21.10				10.66	11.29
GROUND LEVEL											
STATION	NO. 0 + 20		NO. 1		NO. 2	+ 70 + 80 NO. 3	+ 45	NO. 4		NO. 5	+ 75 NO. 6

THE FEASIBILITY STUDY ON
THANH TRI BRIDGE AND THE SOUTHERN SECTION
OF RING ROAD NO. 3 IN HANOI

Profile New NH-1 Interchange (B) Ramp)

DWG
NO.

21

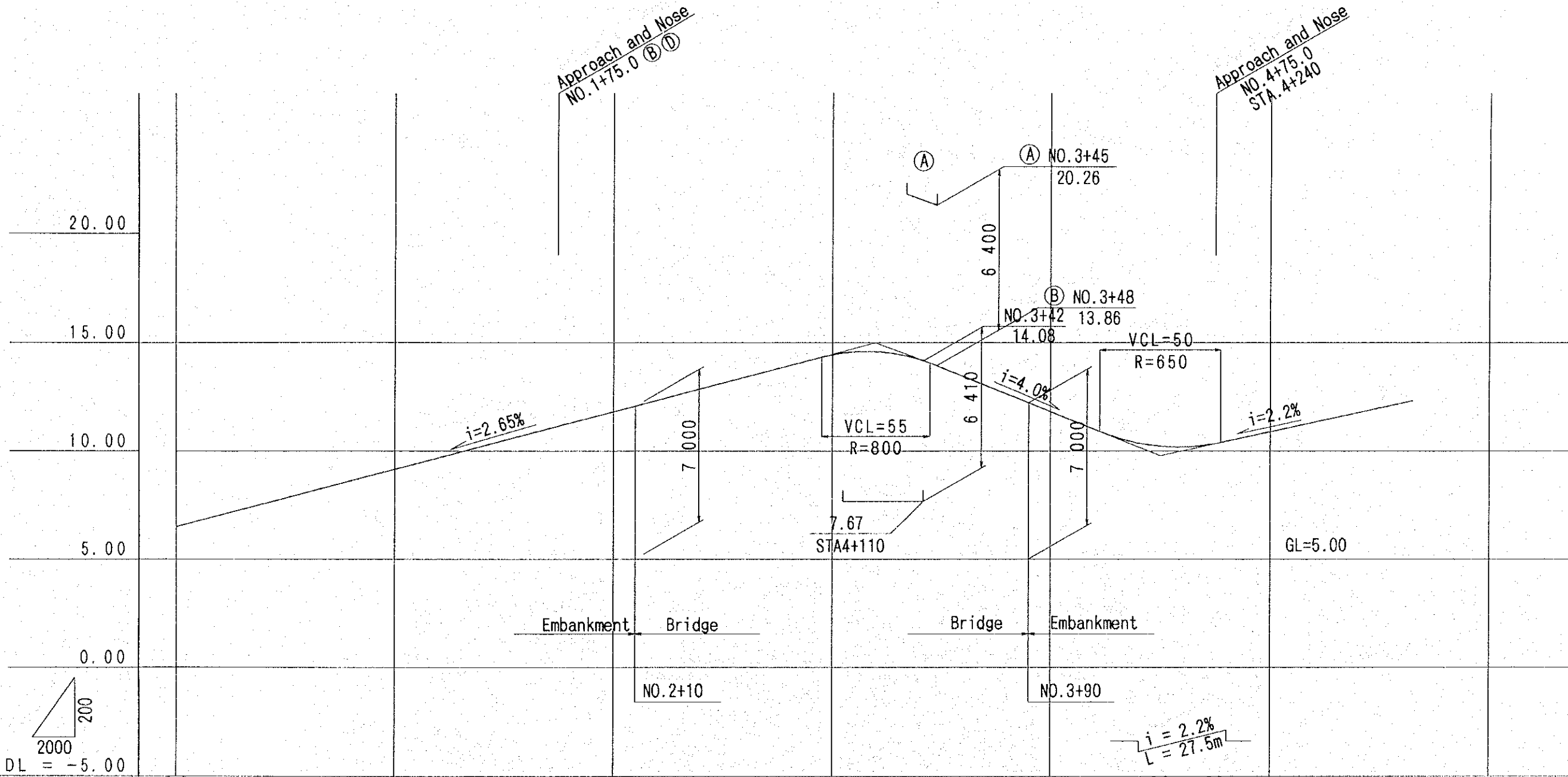

GRADE	6.50	$i = 2.65\%$ $L = 320m$	14.98	$i = 4.0\%$ $L = 130m$	9.78	10.33		
GROUND LEVEL								
STATION	NO. 0	NO. 1	NO. 2	NO. 3 + 20	NO. 4 + 50	NO. 4 + 75	NO. 5	NO. 6

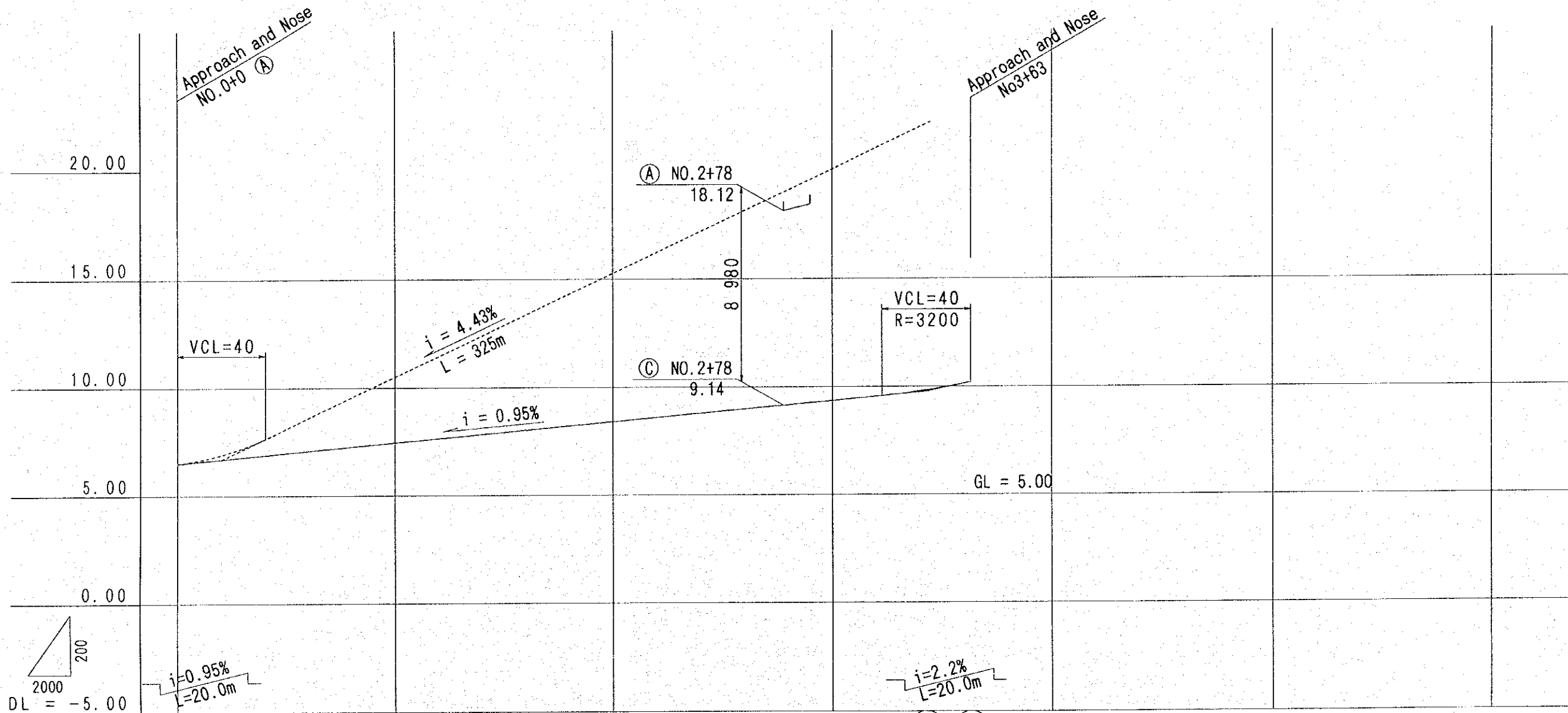

GRADE	6.50	6.69					9.76	10.20					
GROUND LEVEL													
STATION	NO. 0 + 20		NO. 1		NO. 2		NO. 3	+ 43 + 63	NO. 4		NO. 5		NO. 6

THE FEASIBILITY STUDY ON
 THANH TRI BRIDGE AND THE SOUTHERN SECTION
 OF RING ROAD NO. 3 IN HANOI

Profile New NH-1 Interchange(ⒹRamp)

DWG
 NO.

23

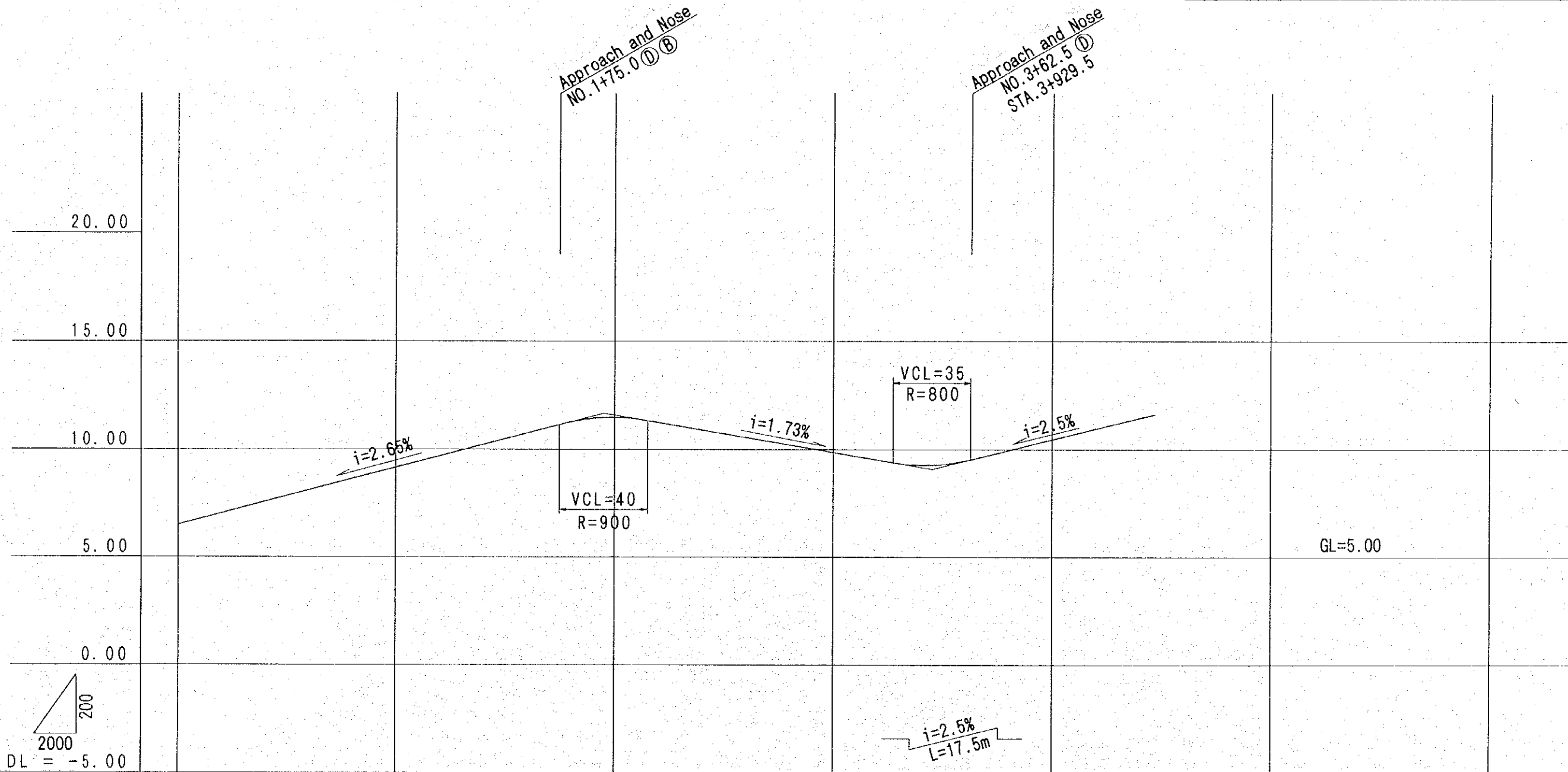

GRADE	6.50	$i=2.65\%$ $L=195m$	11.67	$i=1.73\%$ $L=150m$	9.08	9.52	$i=2.5\%$ $L=17.5m$			
GROUND LEVEL										
STATION	NO. 0	+ 80 NO. 1	+ 95 NO. 2	NO. 3	+ 45 + 62.5	NO. 4		NO. 5		NO. 6