

AGENCIA DE COOPERACION INTERNACIONAL DEL JAPON (JICA)

MINISTERIO DE OBRAS PUBLICAS
REPUBLICA DE CHILE

**PROGRAMA DE REHABILITACION Y CONSERVACION
DE LOS PUENTES
EN LA
REPUBLICA DE CHILE
(FASE 2)**

INFORME FINAL

ANEXO III

**PLANOS DE DISEÑO DE RECONSTRUCCION DE PUENTES
(VOLUMEN 5/8)**

JULIO 1998

PACIFIC CONSULTANTS INTERNATIONAL

PCN LIBRARY

J 1144730 {7}

S S F
J R
98-086

AGENCIA DE COOPERACION INTERNACIONAL DEL JAPON (JICA)

**MINISTERIO DE OBRAS PUBLICAS
REPUBLICA DE CHILE**

**PROGRAMA DE REHABILITACION Y CONSERVACION
DE LOS PUENTES
EN LA
REPUBLICA DE CHILE
(FASE 2)**

INFORME FINAL

ANEXO III

**PLANOS DE DISEÑO DE RECONSTRUCCION DE PUENTES
(VOLUMEN 5/8)**

JULIO 1998

PACIFIC CONSULTANTS INTERNATIONAL



1144730(7)

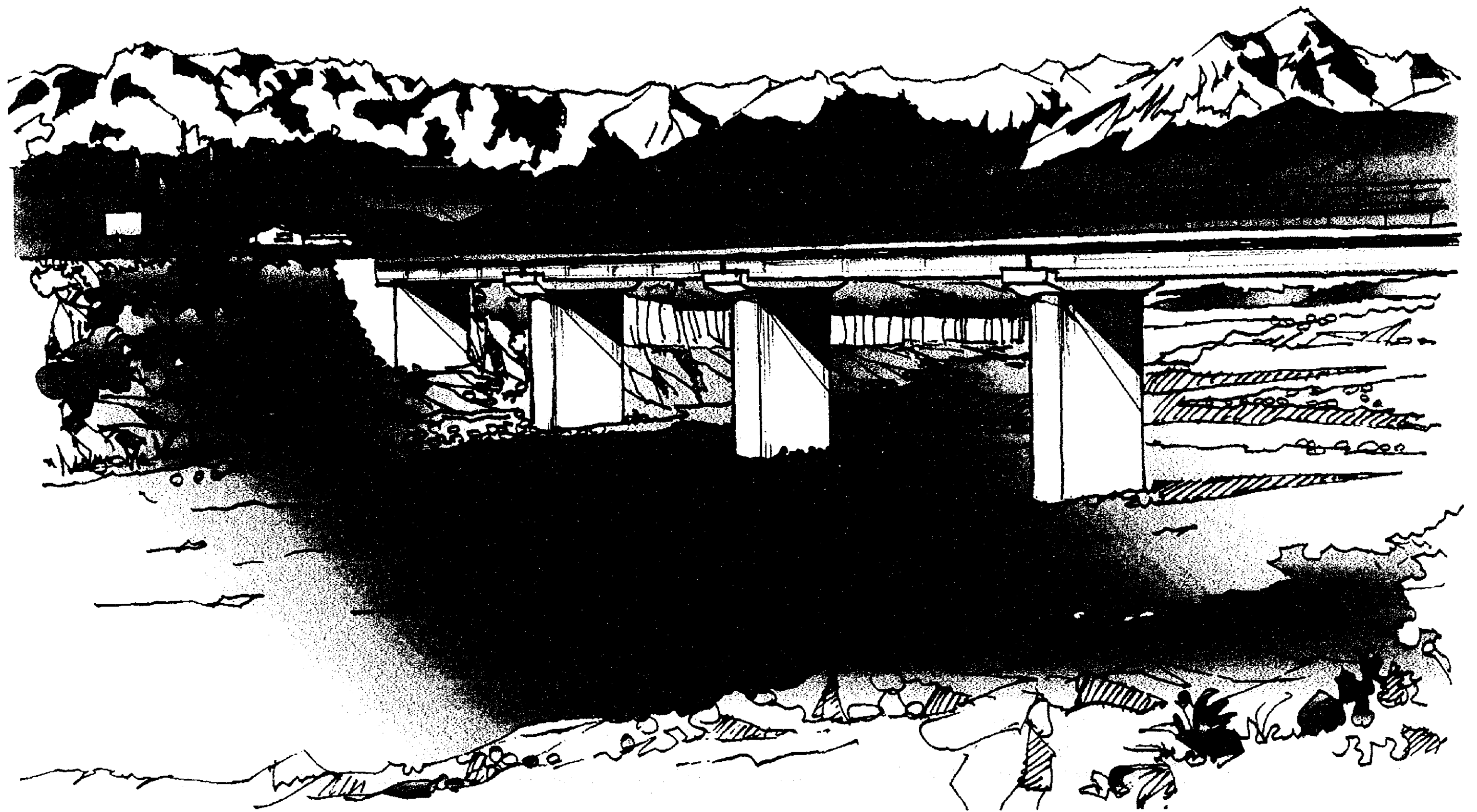

Puente David García de la V Región

CONTENIDOS

I. DAVID GARCIA

1. Planos	1- 1
2. Informe del Cálculo (Tabla de Ingreso y Generalización)	1- 10
3. Lista de Materiales	1- 22

II. GRANALLAS

1. Planos	2- 1
2. Informe del Cálculo (Tabla de Ingreso y Generalización)	2- 7
3. Lista de Materiales	2- 14

III. SAN JOSE

1. Planos	3- 1
2. Informe del Cálculo (Tabla de Ingreso y Generalización)	3- 8
3. Lista de Materiales	3- 17

IV. PUANGUE

1. Planos	4- 1
2. Informe del Cálculo (Tabla de Ingreso y Generalización)	4- 10
3. Lista de Materiales	4- 21

V. SAN JOSE DE MARCHUE

1. Planos	5- 1
2. Informe del Cálculo (Tabla de Ingreso y Generalización)	5- 10
3. Lista de Materiales	5- 22

VI. ANTIVERO No.2

1. Planos	6- 1
2. Informe del Cálculo (Tabla de Ingreso y Generalización)	6- 10
3. Lista de Materiales	6- 22

VII. POCULON

1. Planos	7- 1
2. Informe del Cálculo (Tabla de Ingreso y Generalización)	7- 7
3. Lista de Materiales	7- 14

VIII. SAN JUAN

1. Planos	8- 1
2. Informe del Cálculo (Tabla de Ingreso y Generalización)	8- 7
3. Lista de Materiales	8- 12

Tabla de Variables Diseño

I. DAVID GARCIA

1. Planos

(1) Planos de Vista General.....	1- 1
(2) Superestructura de Postensado	1- 2
(3) Infraestructura A1 Estribo	1- 4
(4) Infraestructura A2 Estribo	1- 6
(5) Infraestructura P1 Cepa	1- 8
(6) Infraestructura P2,P3 Cepa	1- 9

2. Informe del Cálculo (Tabla de Ingreso y Generalización)

(1) Superestructura de Postensado	1- 10
(2) Infraestructura A1 Estribo	1- 12
(3) Infraestructura A2 Estribo	1- 15
(4) Infraestructura P1 Cepa	1- 18
(5) Infraestructura P2,P3 Cepa	1- 20

3. Lista de Materiales

(1) Resumen de Cubicaciones	1- 22
(2) Superestructura de Postensado	1- 23
(3) Infraestructura A1 Estribo.....	1- 25
(4) Infraestructura P1 Cepa.....	1- 27
(5) Infraestructura P2,P3 Cepa.....	1- 29
(6) Infraestructura A2 Estribo.....	1- 31

CORTE LONGITUDINAL
ESC. 1:250

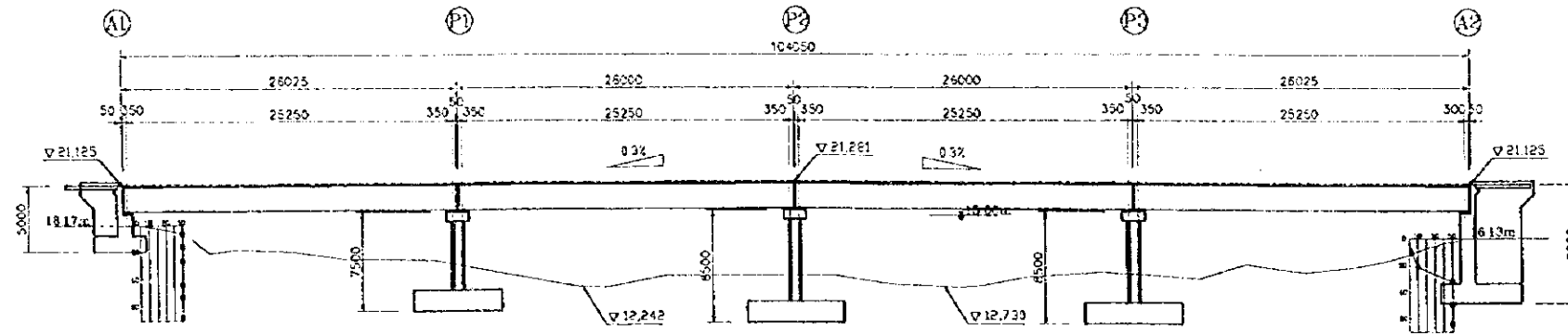

SECCION DE VIGA
ESC. 1:100

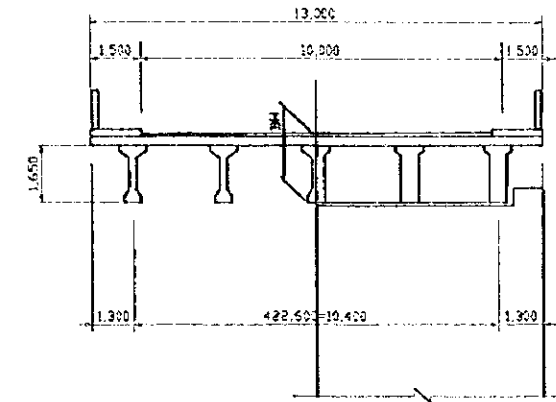

PLANTA
ESC. 1:250

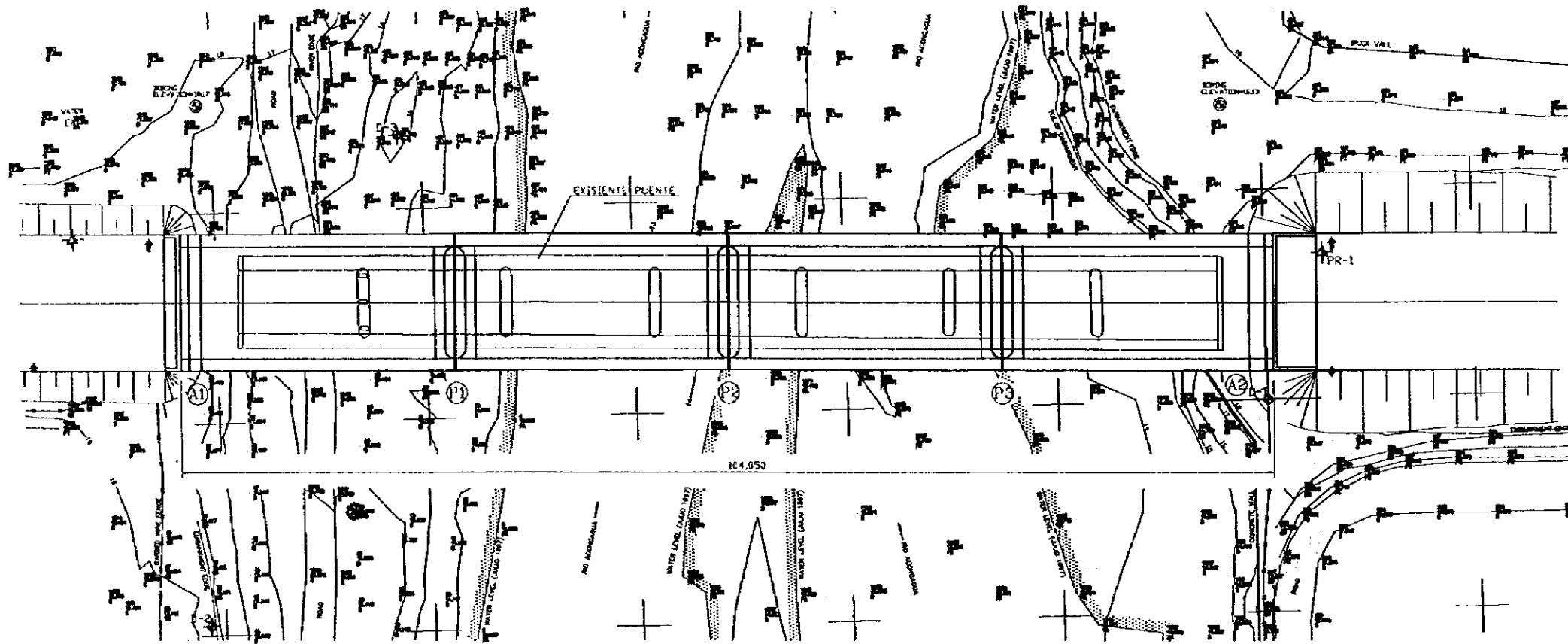

DETALLE DE BH

Pavimento	125
Loso	200
Viga	1650
Apoyo	50
Pedestal	100
Total	2125

ESTRIBO A1
ESC. 1:150

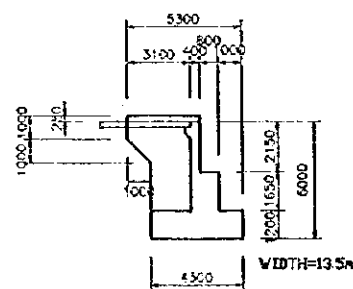

PILA P2, P3, P1
ESC. 1:150

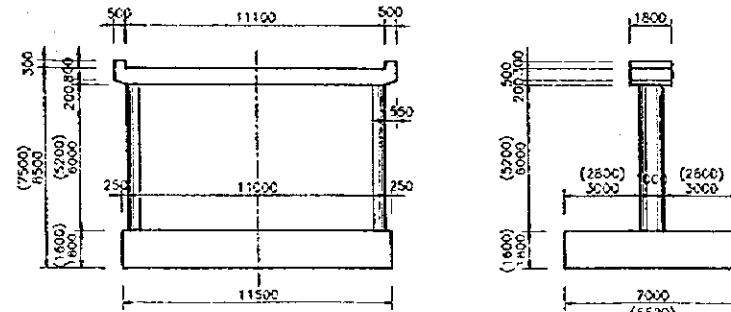

ESTRIBO A2
ESC. 1:150

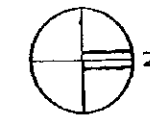
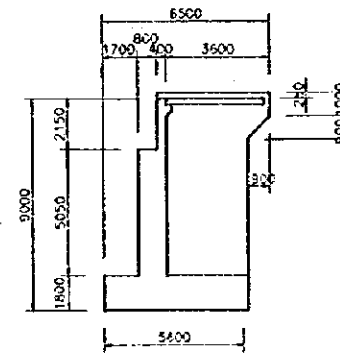

DIRECCION DE VIALIDAD DEPARTAMENTO DE PUENTES	
Puente: DAVID GARCIA	
Camino:	
Provincia:	Region: V
Proyecto:	Reviso:
Vo de Ing. Jefe Depto. Puentes	Director de Vialidad
Fecha:	Vista General

1/2 ELEVACION DE VIGA POSTENSADO
ESC. 1:50

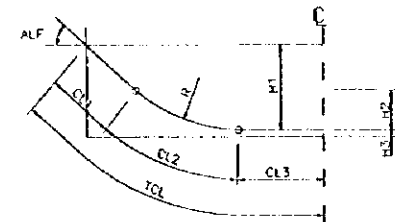
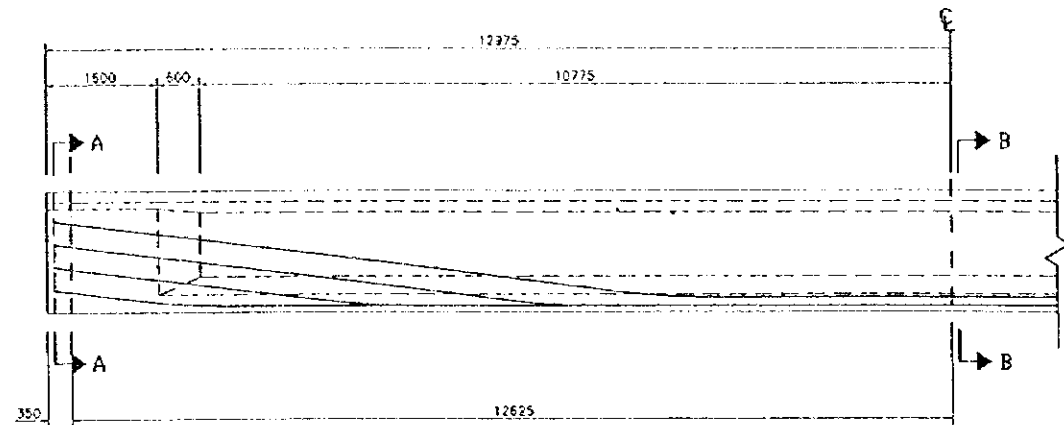

	ALF	R	H1	H2	H3	CL1	CL2	CL3	TCL
D1	7	10	1070	75	210	8158	1222	3543	12939
D2	7	10	870	75	90	6527	1222	5178	12927
D3	7	10	550	75	90	3901	1222	7784	12907
D4	7	10	230	75	90	1275	1222	10390	12888

1/2 ENFIERRADURA VIGA POSTENSADO
ESC. 1:50

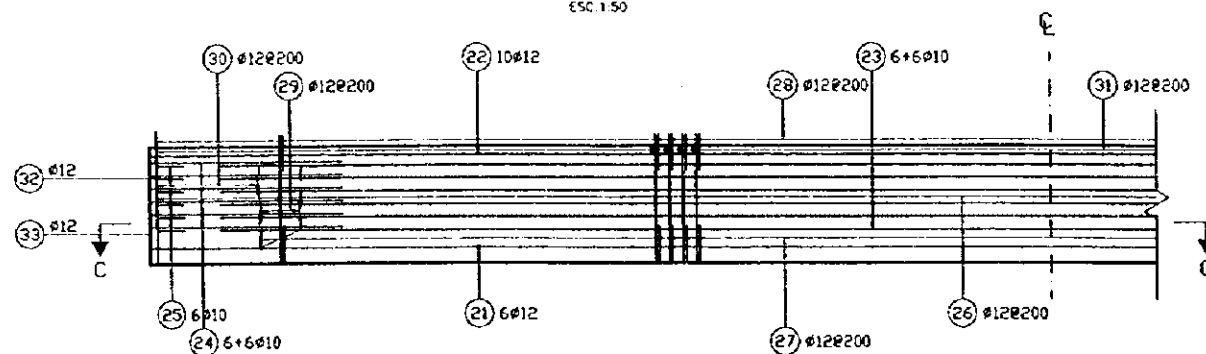

CORTE A-A
ESC. 1:20

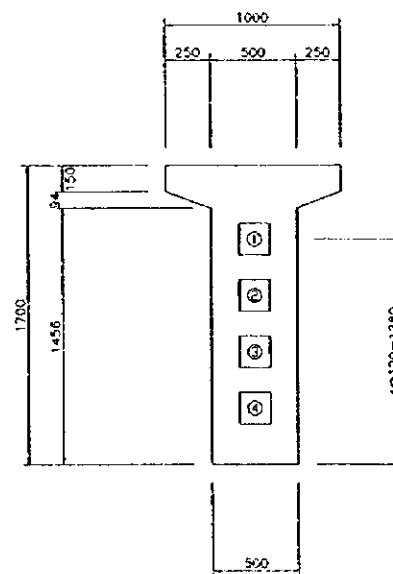

CORTE B-B
ESC. 1:20

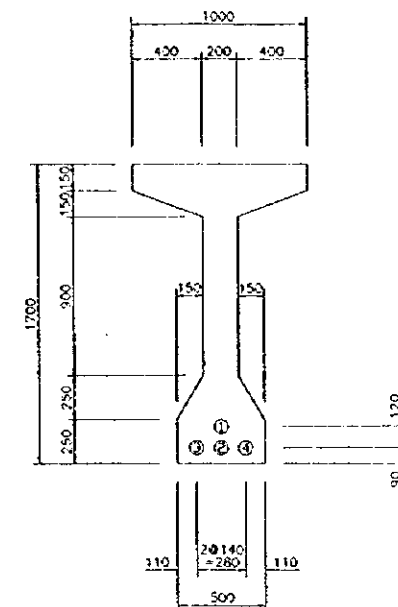

CORTE C-C
ESC. 1:50

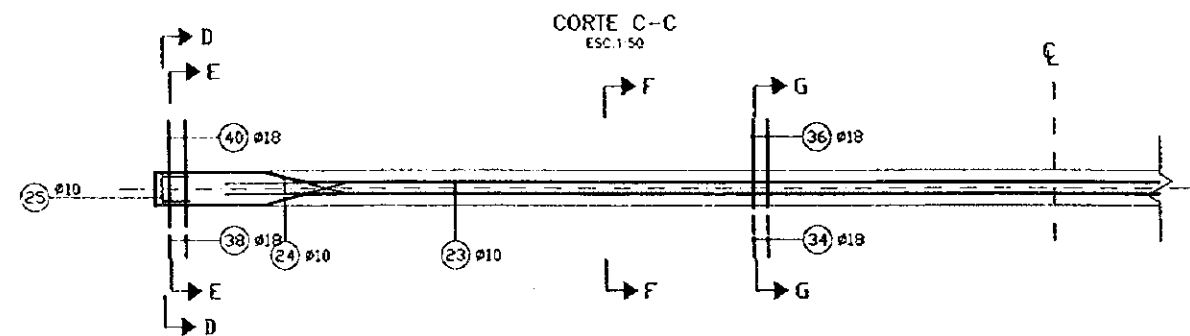

CORTE D-D
ESC. 1:25

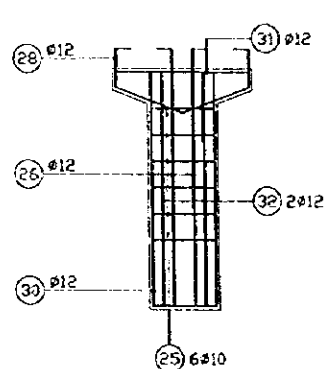

CORTE E-E
ESC. 1:25

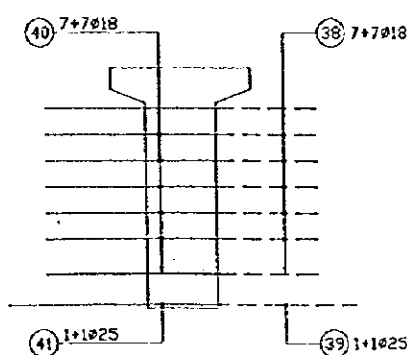

CORTE F-F
ESC. 1:25

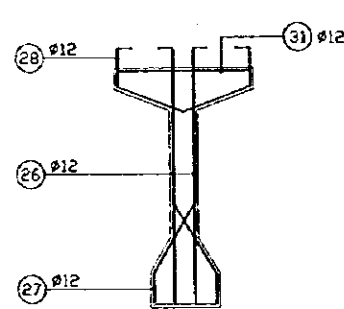

CORTE G-G
ESC. 1:25

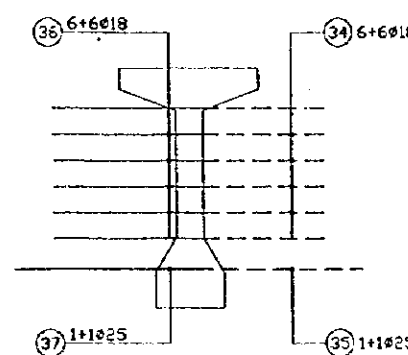

DIRECCION DE VIALIDAD DEPARTAMENTO DE PUENTES	
Puente: DAVID GARCIA	
Camino:	
Provincia:	Region: V
Proyecto:	Reviso:
Vo Bo Ing. Jefe Depto. Puentes	Director de Vialidad
De: _____	Fecha: _____

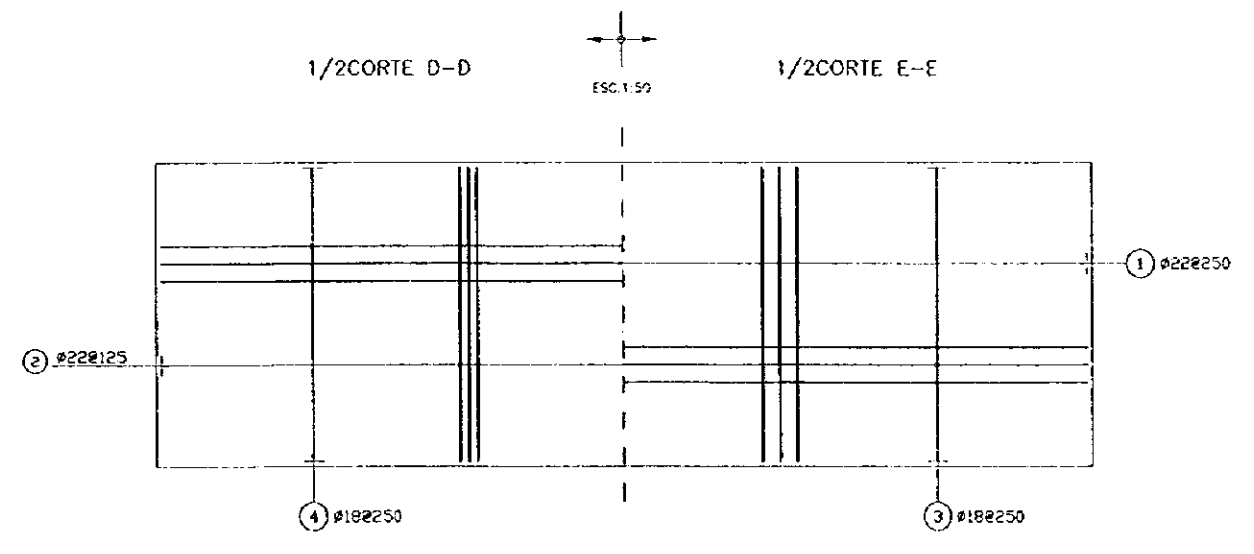
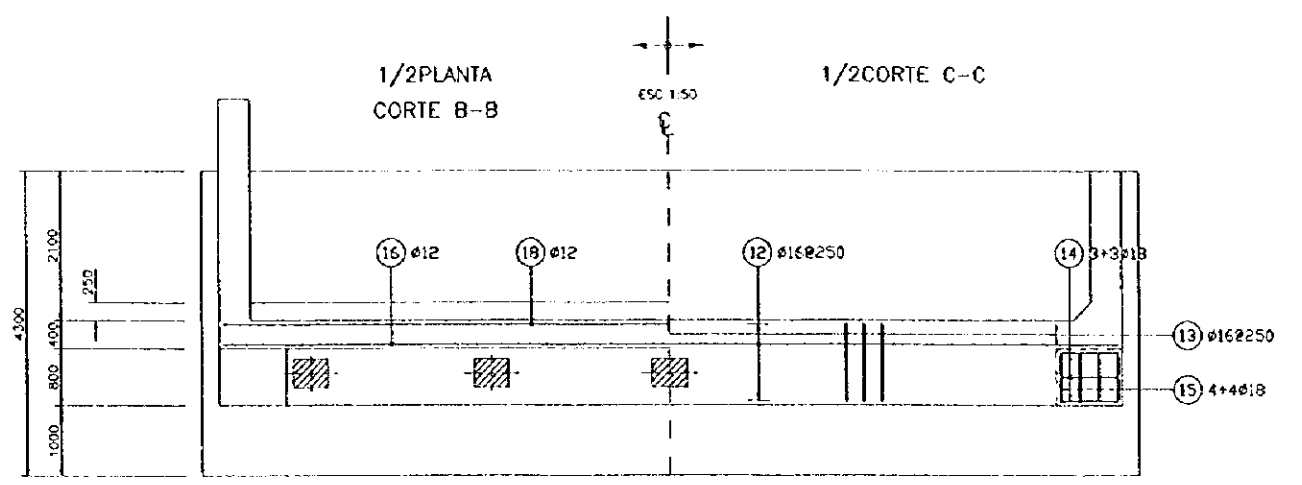
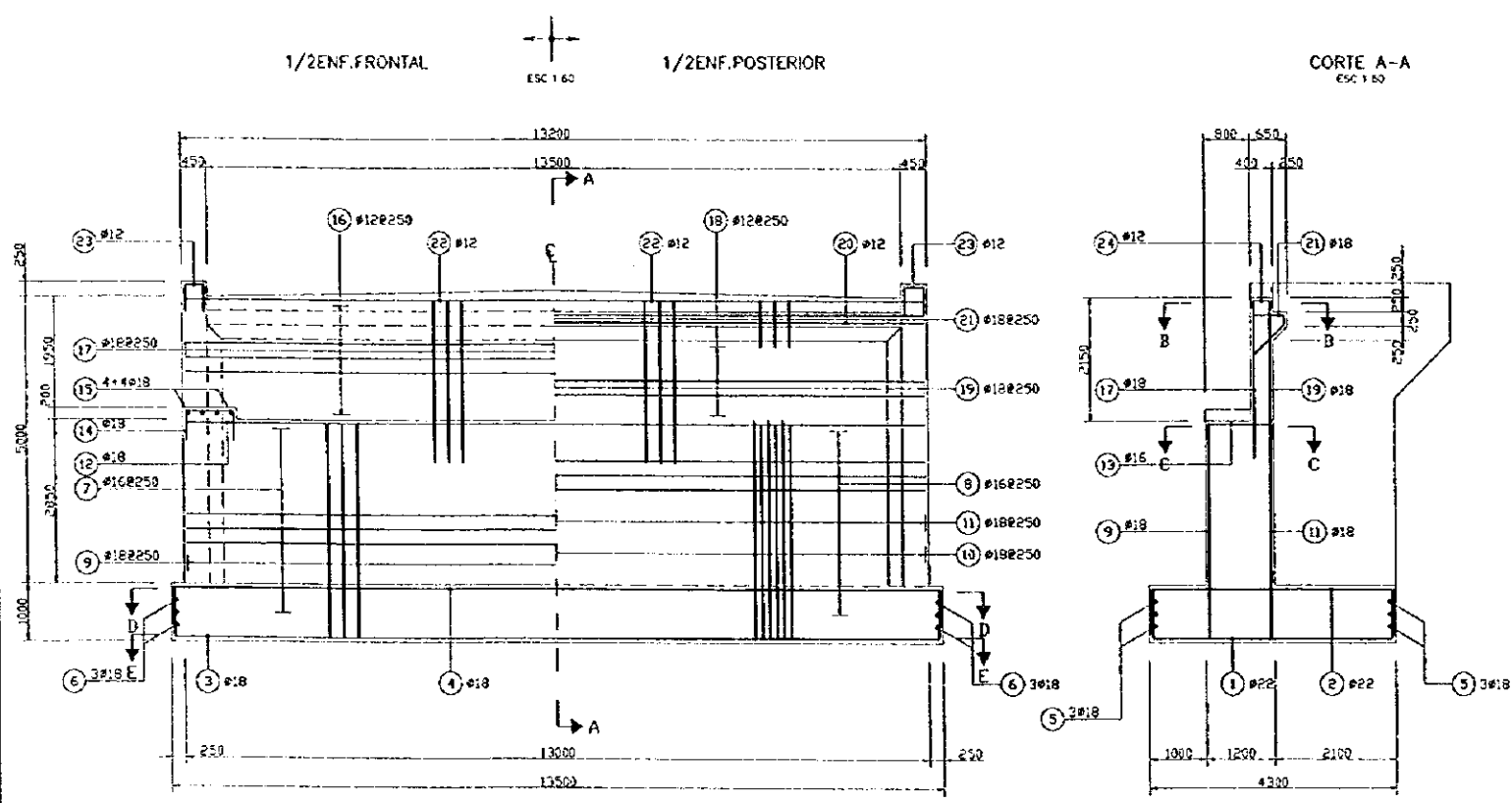

DIRECCION DE VIALIDAD DEPARTAMENTO DE PUENTES	
Puente: DAVID GARCIA A1	
Camino:	
Provincia:	Region: V
Projecto	Reviso
Va. Sr. Ing. Jefe Depto. Puentes	Director de Vialidad
Elaborado	Fecha:

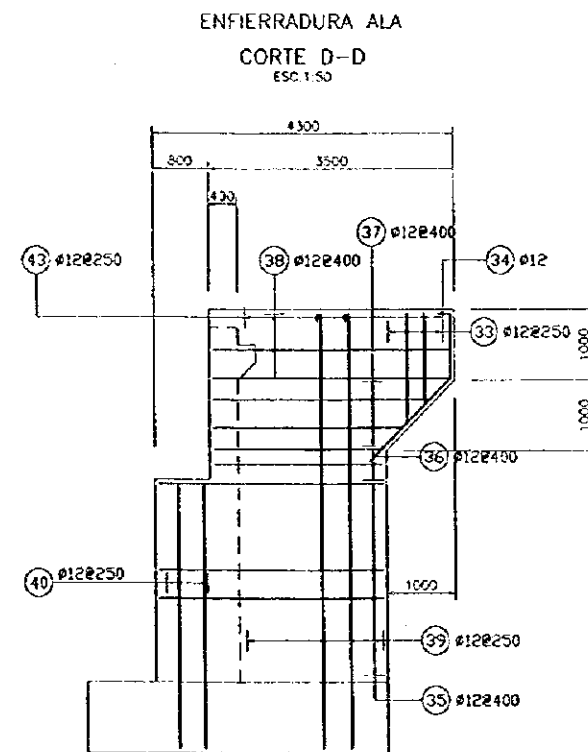
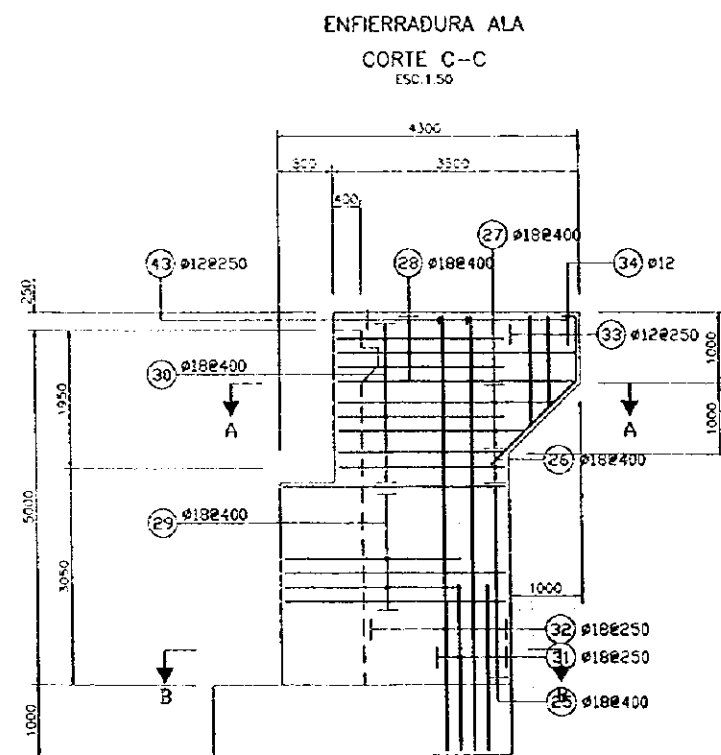
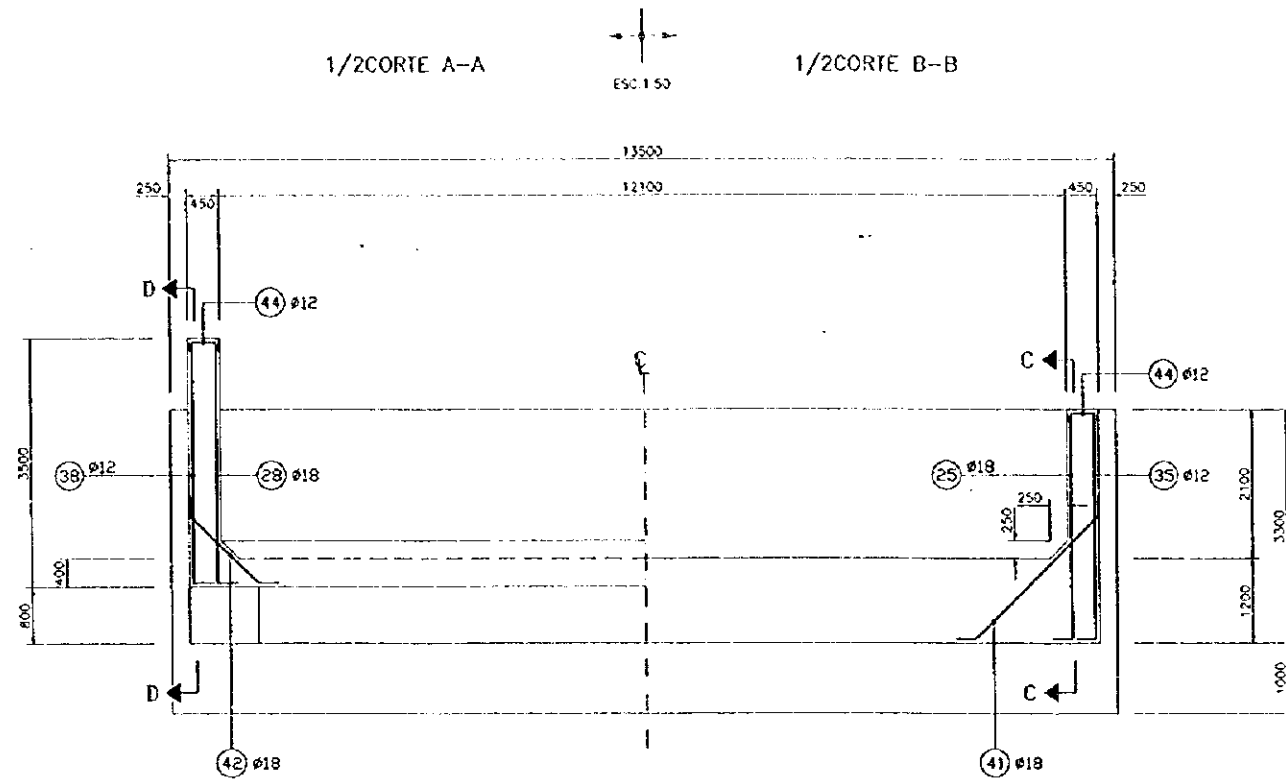

DIRECCION DE VIALIDAD DEPARTAMENTO DE PUENTES	
Puente: DAVID GARCIA A1	
Camino:	
Provincia:	Region: V
_____ Proyecto	_____ Año/s
_____ Yo So Inq. Jefe Depto. Puentes	_____ Director de Vialidad
_____ Fecha	

EREVACION CEPA
ESC 1:50

EREVACION LATERAL
ESC 1:50

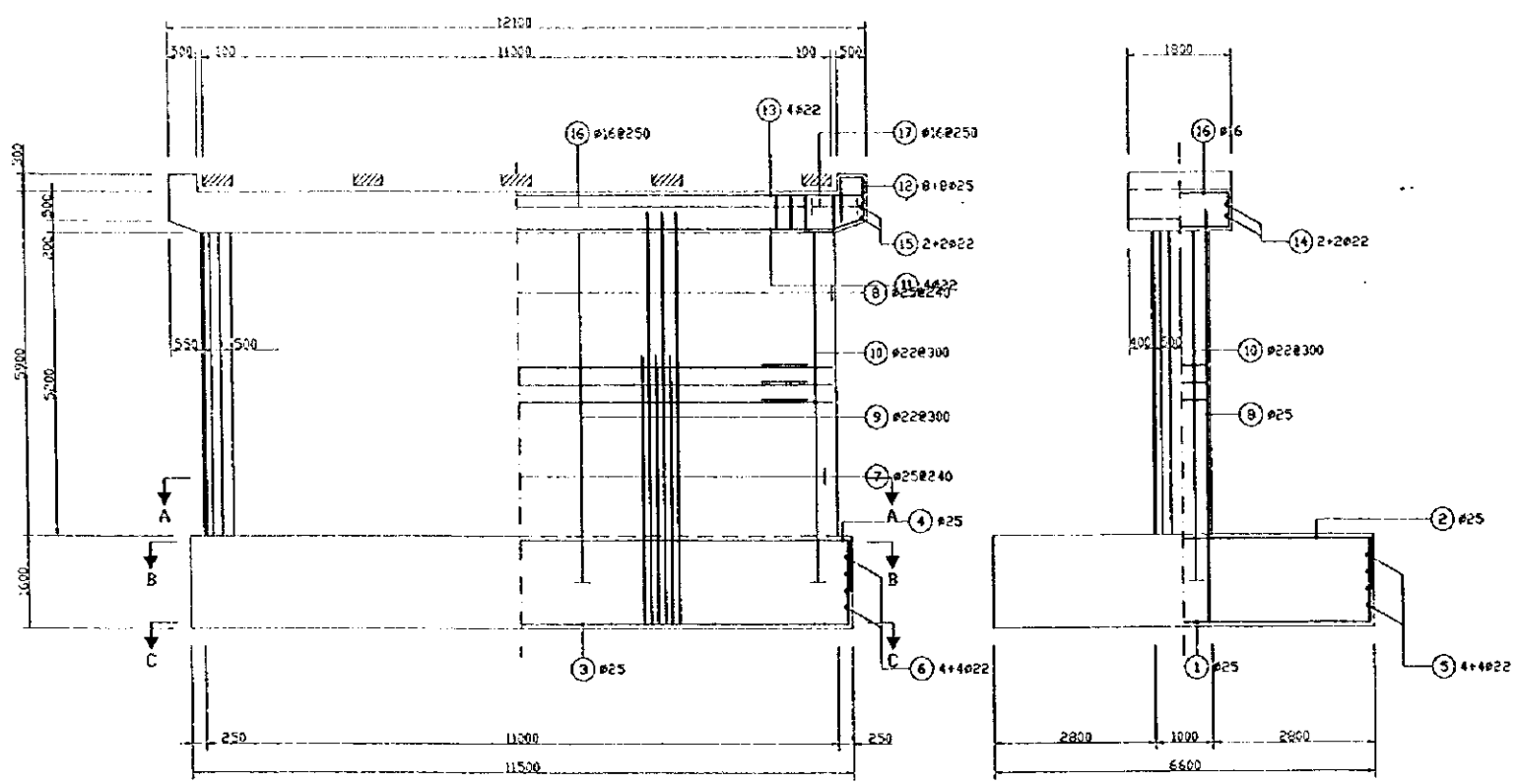

1/2 PLANTA CEPA
ESC. 1:50

1/2 CORTE A-A

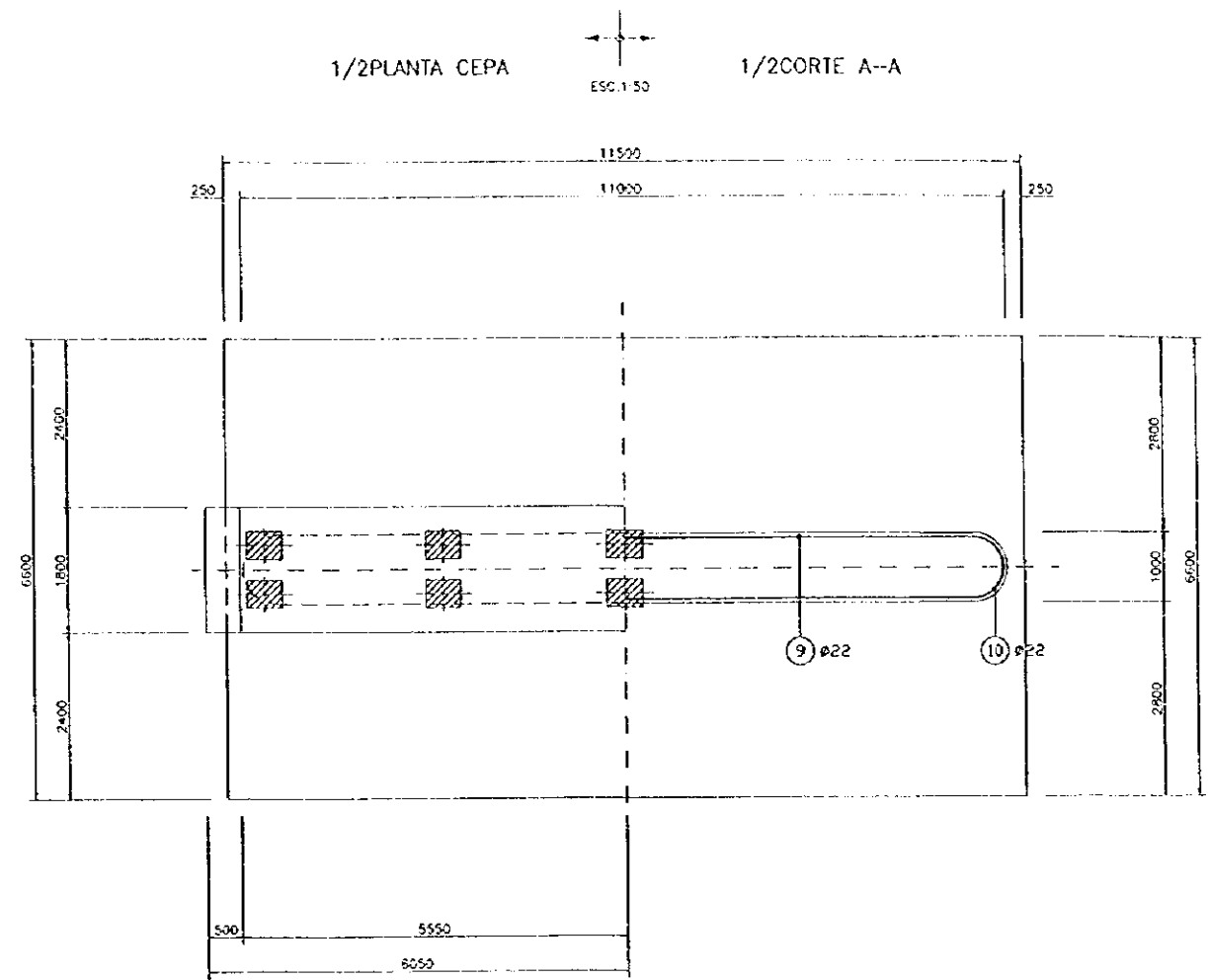

1/2 CORTE B-B
ESC 1:50

1/2 CORTE C-C

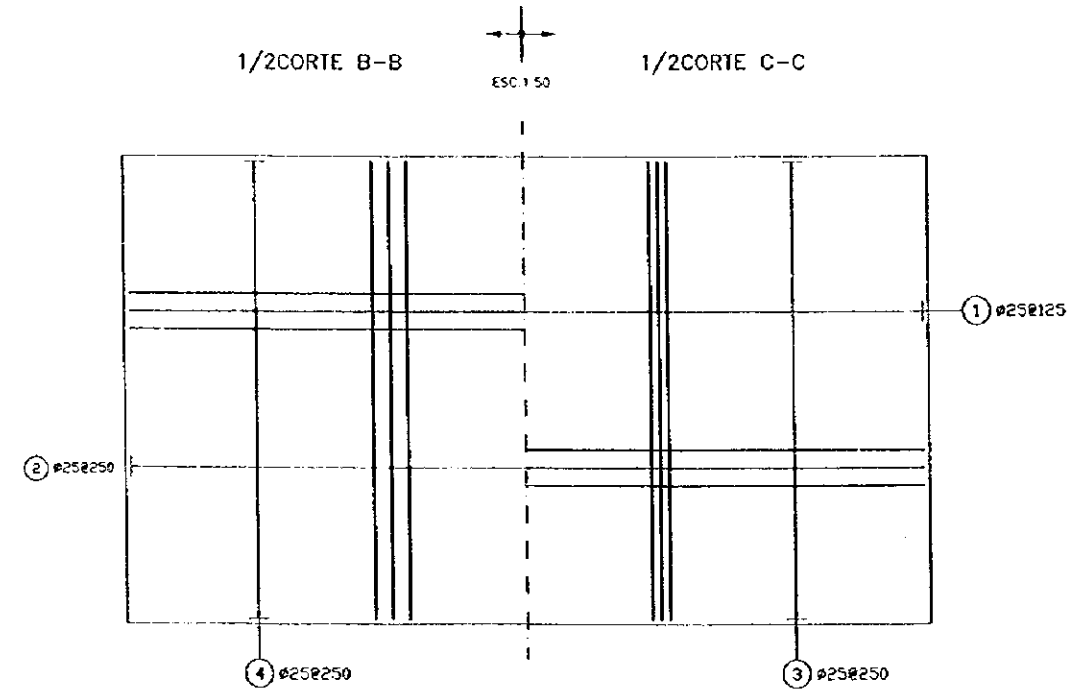

DIRECCION DE VIALIDAD DEPARTAMENTO DE PUENTES	
Puente: DAVID GARCIA P1	
Camino:	
Provincia:	Region: V
_____ Proyecto	_____ Reviso
_____ Va. Bn. Ing. Jefe Depto. Puentes	_____ Director de Vialidad
_____ Dibujante	_____ Fecha

EREVACION CEPA
ESC 1:50

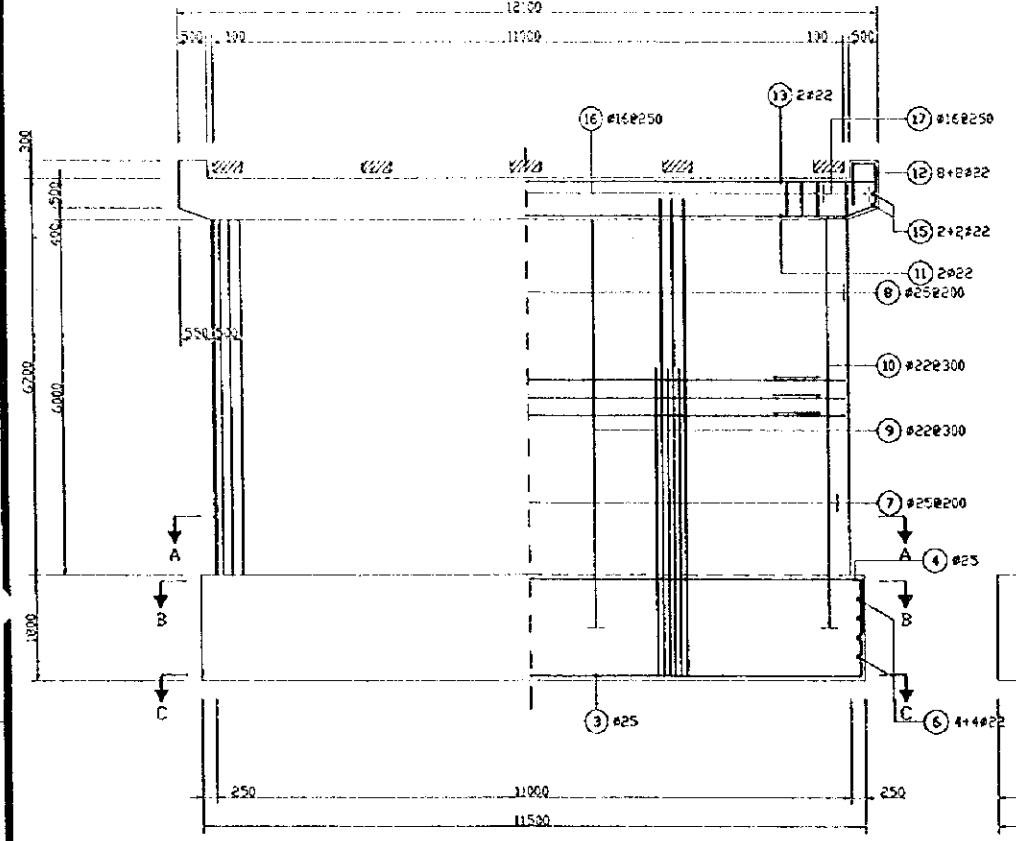

EREVACION LATERAL
ESC 1:50

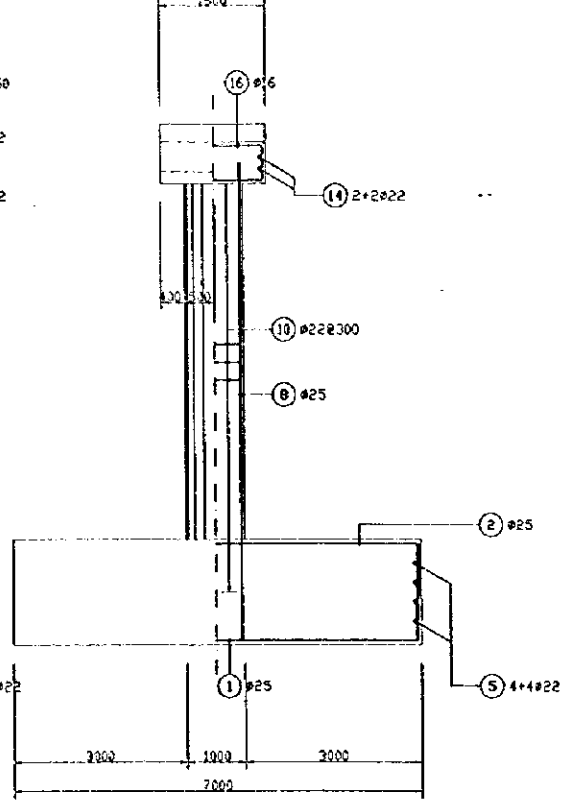

1/2CORTE B-B

1/2CORTE C-C

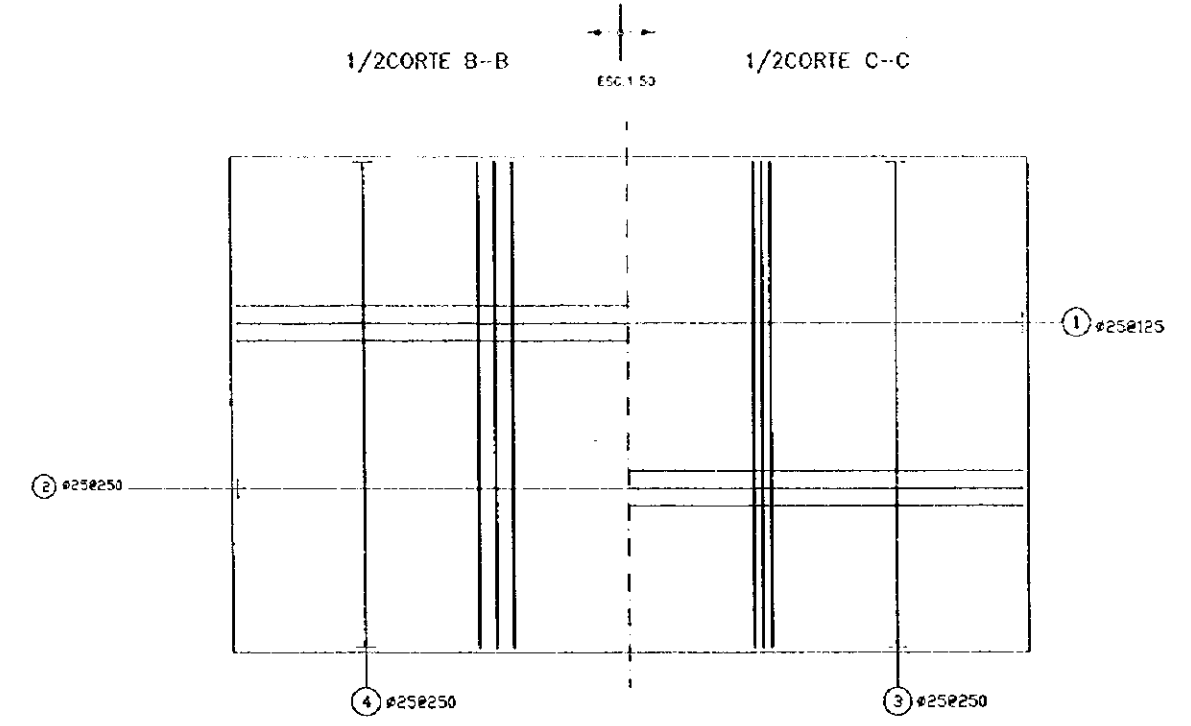

1/2PLANTA CEPA
ESC 1:50

1/2CORTE A-A

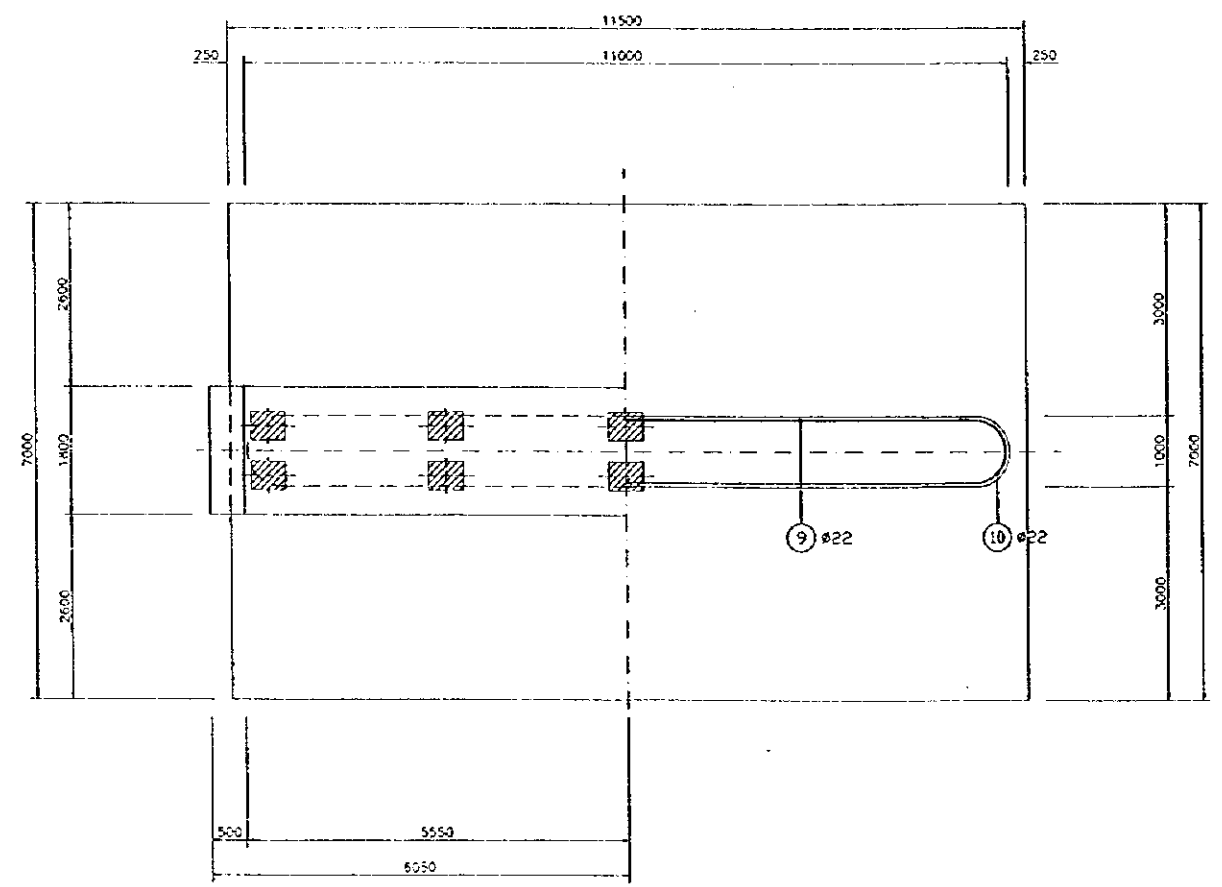

DIRECCION DE VIALIDAD DEPARTAMENTO DE PUENTES	
Puente: DAVID GARCIA P2,P3	
Camino:	
Provincia:	Region: V
_____ Proyecto	_____ Reviso
_____ Vo. Bo. Ing. Jefe Depto. Puentes	_____ Director de Vialidad
_____ Edujo	_____ Fecha:

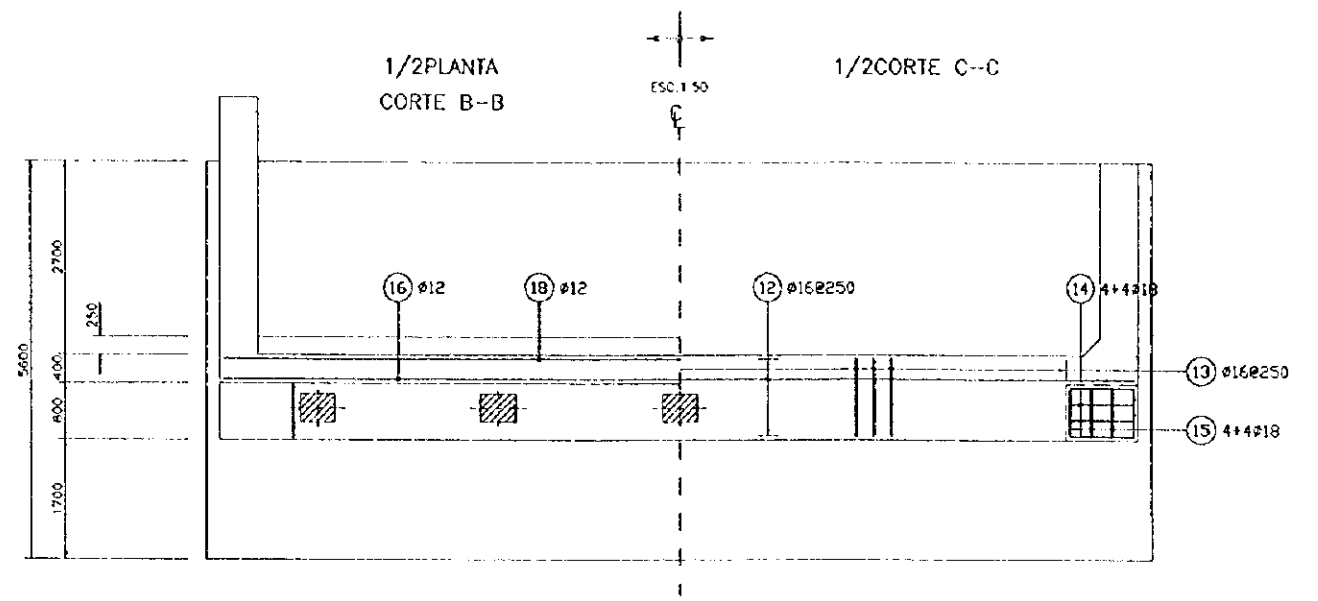

1/2 ENF. FRONTAL ESC. 1:60 1/2 ENF. POSTERIOR ESC. 1:60 CORTE A-A ESC. 1:60

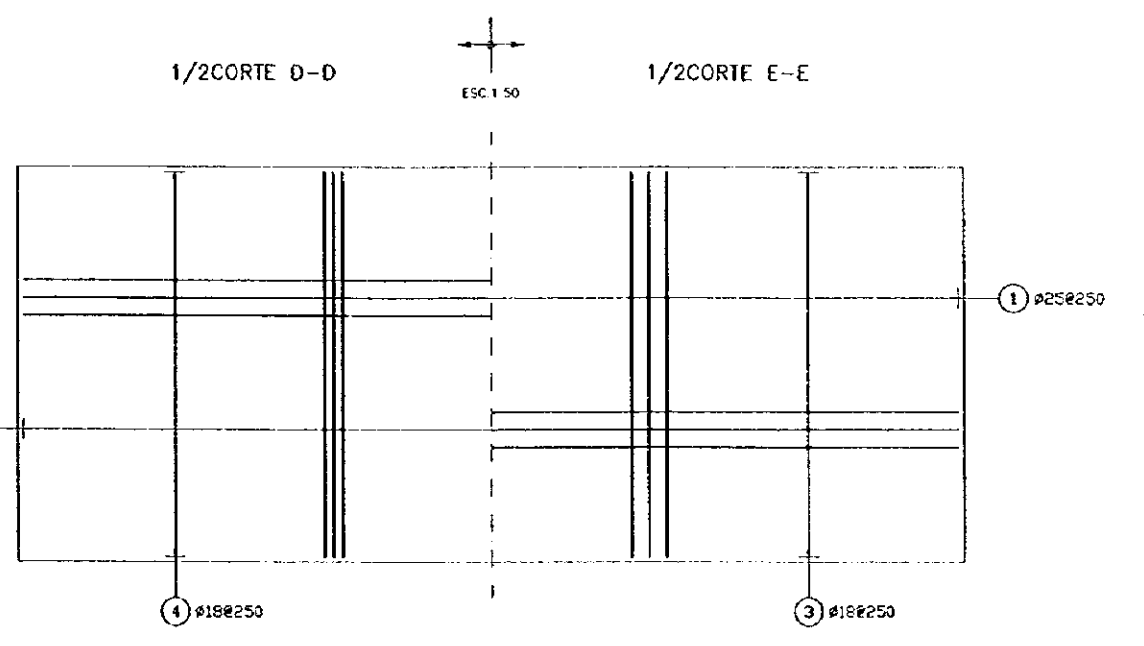
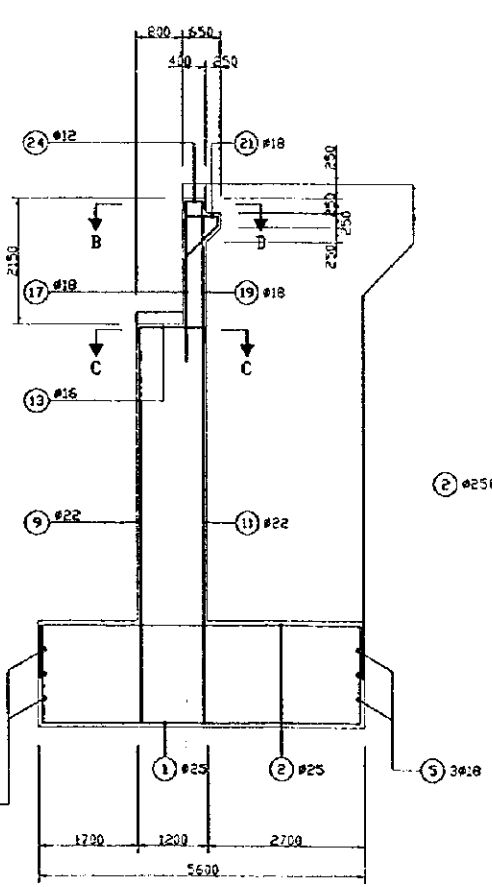
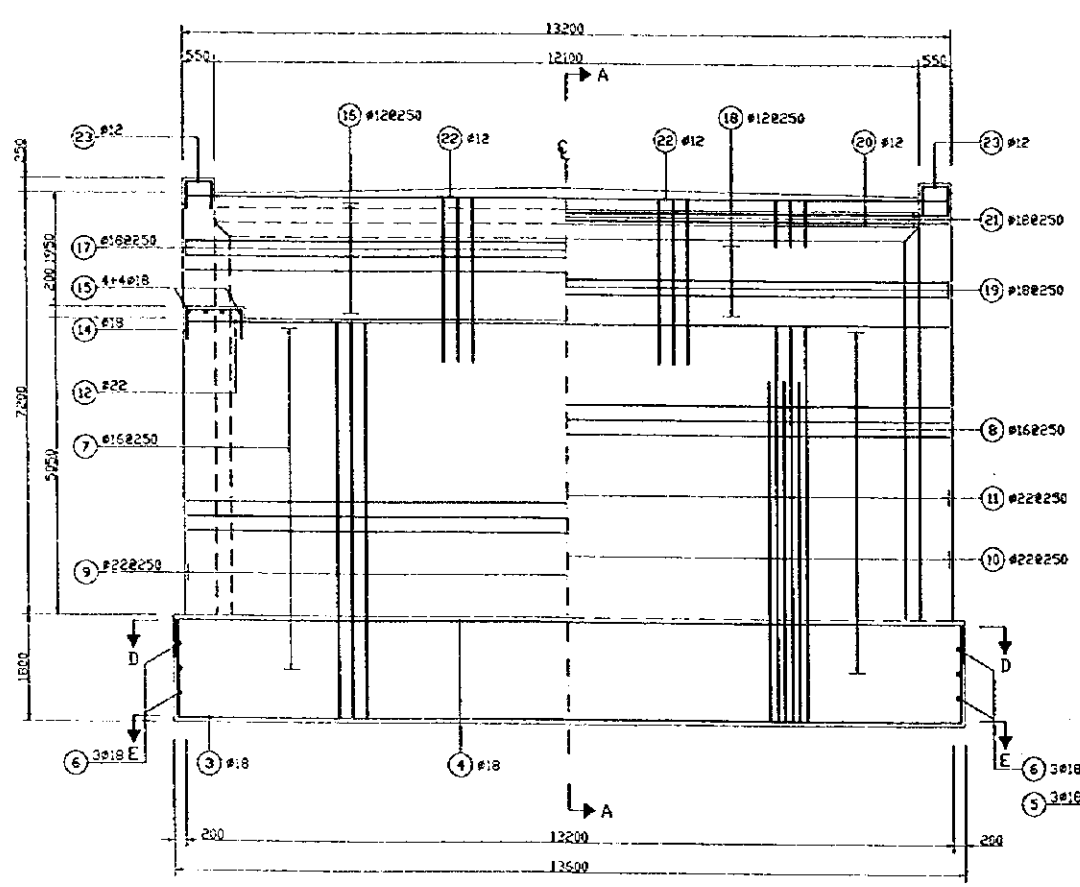

DIRECCION DE VIALIDAD DEPARTAMENTO DE PUENTES	
Puente: DAVID GARCIA A2	
Camino:	
Provincia:	Region: V
_____ Proyecto	_____ Reviso
_____ Va Bo Ing. Jefe Depto. Puentes	_____ Director de Vialidad
Dibujo	Fecha:

1/2CORTE A-A

1/2CORTE B-B

ESC. 1/50

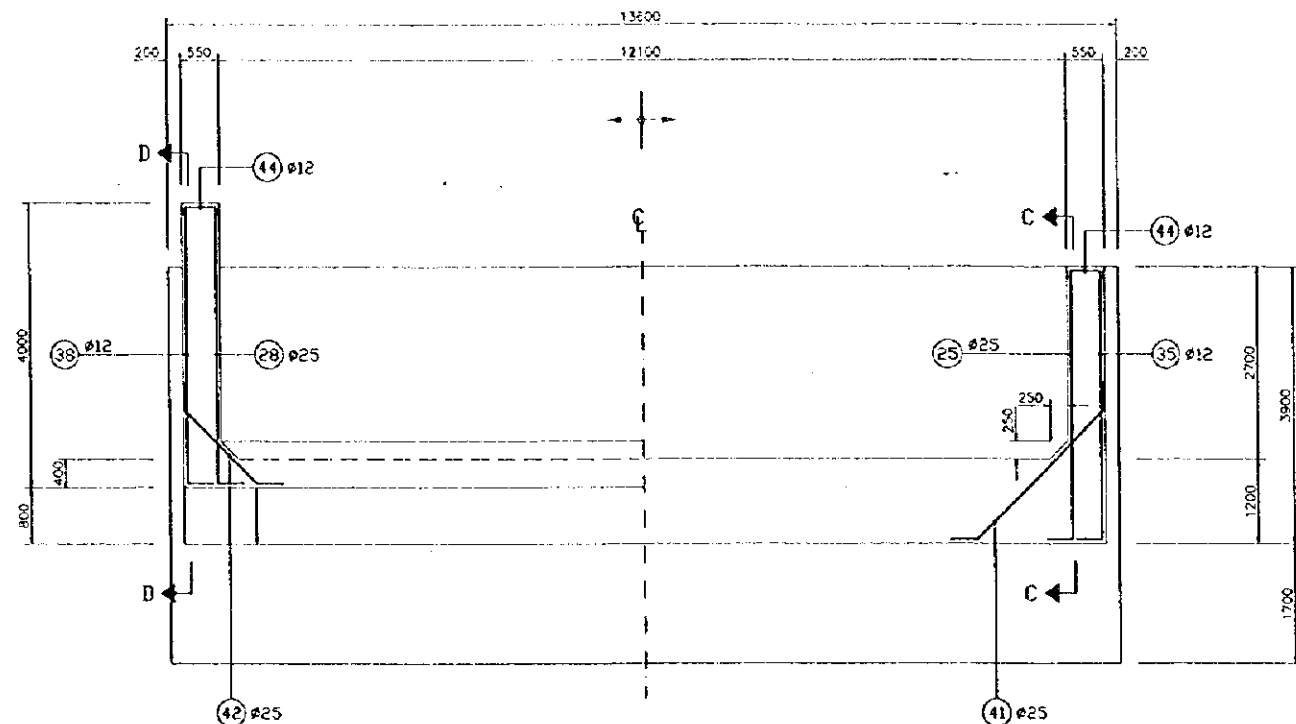

ENFIERRADURA ALA CORTE C-C

ESC. 1/50

ENFIERRADURA ALA CORTE D-D

ESC. 1/50

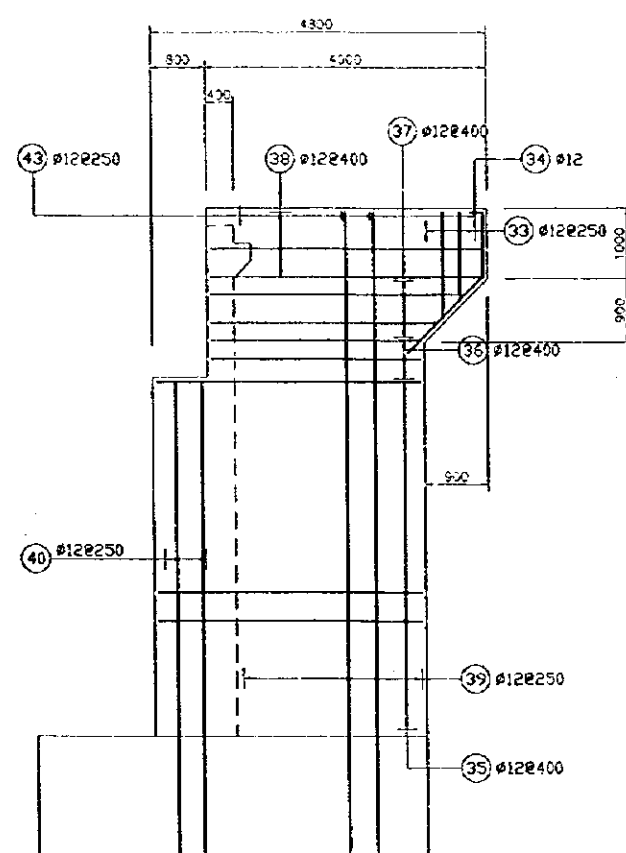
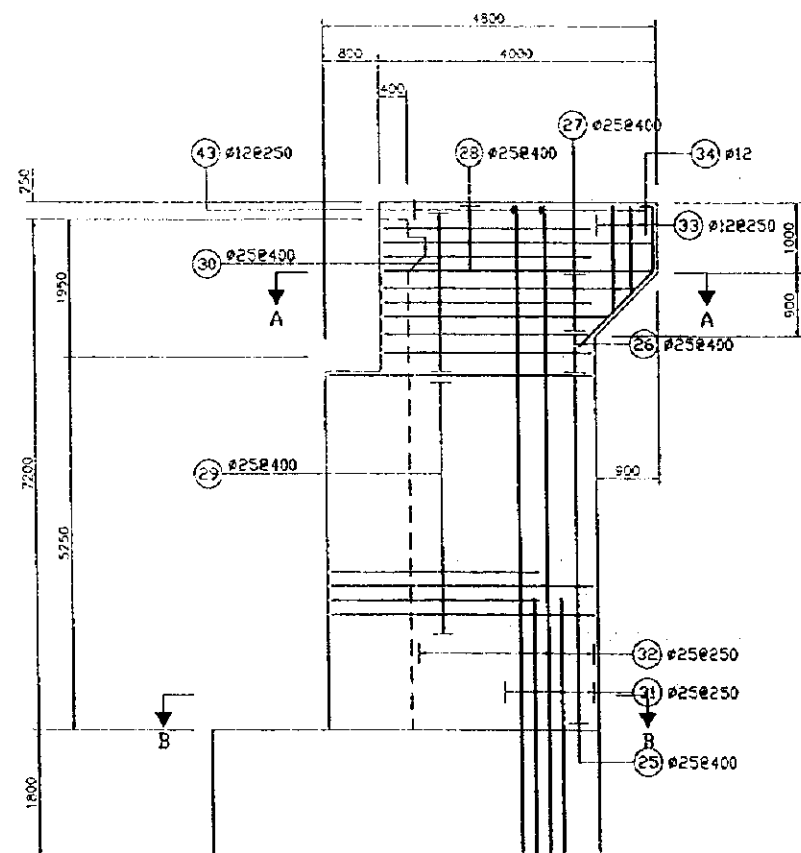

DIRECCION DE VIALIDAD DEPARTAMENTO DE PUENTES	
Puente: DAVID GARCIA A2	
Camino:	
Provincia:	Region: V
Proyecto	Reviso
Va. Ing. Jefe Depto. Puentes	Director de Vialidad
Dibujo Fecha:	

Resultado del diseño

Tipo de Estructura : Viga de Postensado

Fecha :

(1) Datos Generales

Número de Puente :

Nombre del Puente : DAVID GARCIA

De la Ruta, Camino:

Rol Ruta :

En el Cauce :

Región : V : VALPARAISO

Provincia :

Longitud del Puente : $L = 104.050$ m , Luz(Longitud de cálculo) : $L_c = 25.250$ m

Número de Pistas : 2

Ancho : $1.500 + 10.000 + 1.500 = 13.000$ m

(Pasillos) (Calzada) (Pasillos)

Pendiente : 1.0 1.5 1.0 %

Espesor mínimo del Pavimento : 50 mm , Espesor máximo del Pavimento : 125 mm

Ancho de Baranda : $B_b = 200$ mm , $h_b = 0.250$ m

(2) Cargas

Baranda : $W_B = 0.050$ t/m , $W_L = 0.020$ t/m , $h = 1.100$ m

Cargas de Pavimento : 2.30 t/m³

Hormigón : 2.30 t/m³ (en masa) , 2.50 t/m³ (armado y/o postensado)

Acero : 7.85 t/m³

Peatones : $W_p = 0.415$ t/m² (Losa)
 0.293 t/m² (Viga)

Cargas de Tránsito : HS20-44

Cargas de Viento : $W_v = 0.244$ t/m²

Coefficientes sísmicos : $K_b = 0.15$, $K_v = 0.00$

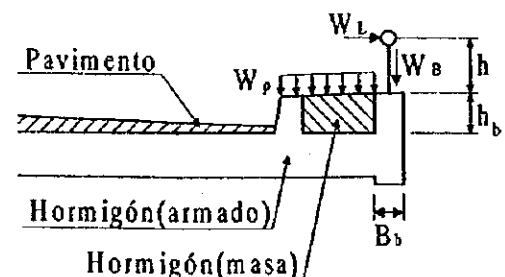

(3) Material

Hormigón :

Losa y Travesaño grado : H-30 $f_{cL} = 250$ kg/cm² , $f_{RC} = 100$ kg/cm²
 $E_{RC} = w_c^{1.5} \times 33 \sqrt{f_{RC}} = 57000 \sqrt{f_{RC}} \text{ psi} = 15800 \sqrt{f_{RC}} \text{ kg/cm}^2 = 2.50 \times 10^5 \text{ kg/cm}^2$
 $w_c = 145 \text{ pcf} = 2.32 \text{ kg/m}^3$ (AASHTO 8.7.1)

Viga grado : H-40 $f_{cV} = 350$ kg/cm² , $E_{PC} = 3.01 \times 10^5$ kg/cm²
 $f_{ci} = 280$ kg/cm² , $E_{Pi} = 2.69 \times 10^5$ kg/cm²

Acero para Armadura de Losa y Viga : A63-42H $f_y = 4200$ kg/cm² , $f_{sa} = 1690$ kg/cm²
 $E_s = 29,000,000 \text{ psi} = 2.1 \times 10^6 \text{ kg/cm}^2$

Acero Travesaño y barras antisísmicas : A44-28H $f_y = 2800$ kg/cm² , $f_{sa} = 1400$ kg/cm²

Acero (cable) : Grado 270 K , ASTM416-80 Cable : 7-12.7 $As^* = 6.910$ cm²

Tensión de ruptura : $f_{pu} = 18980$ kg/cm² , $E_s = 1.97 \times 10^6$ kg/cm²

Tensión de fluencia : $f_{py} = 16100$ kg/cm²

(4) Geometría :

Determinación de número de barras y espaciamiento : $\phi 16 @ 150$ $As = 13.407$ cm²

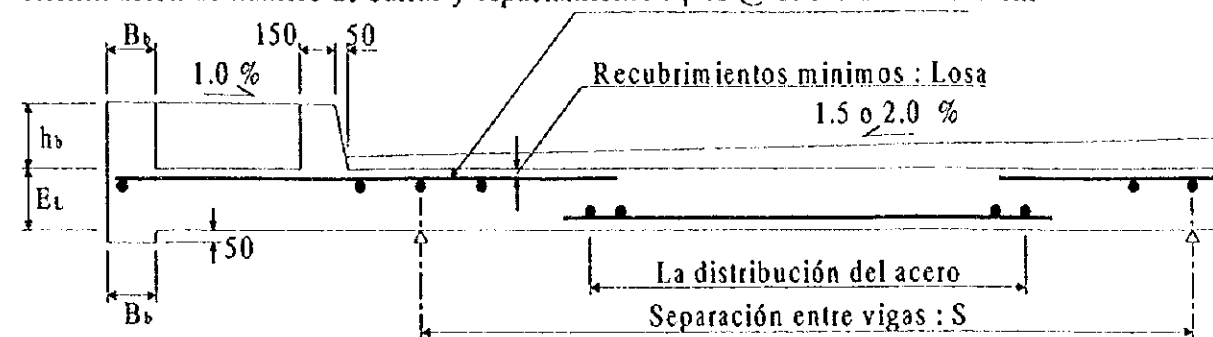

Espesor de losa : $E_L = 170$ mm , Recubrimientos mínimos : Losa 3.0 cm

La distribución del acero en el fondo de losa : $\phi 12 @ 125$ $As = 9.048$ cm²

Número de Vigas : $n_v = 5$, Separación entre vigas : $S = 2.600$ m , $4 @ 2.600 = 10.400$ m

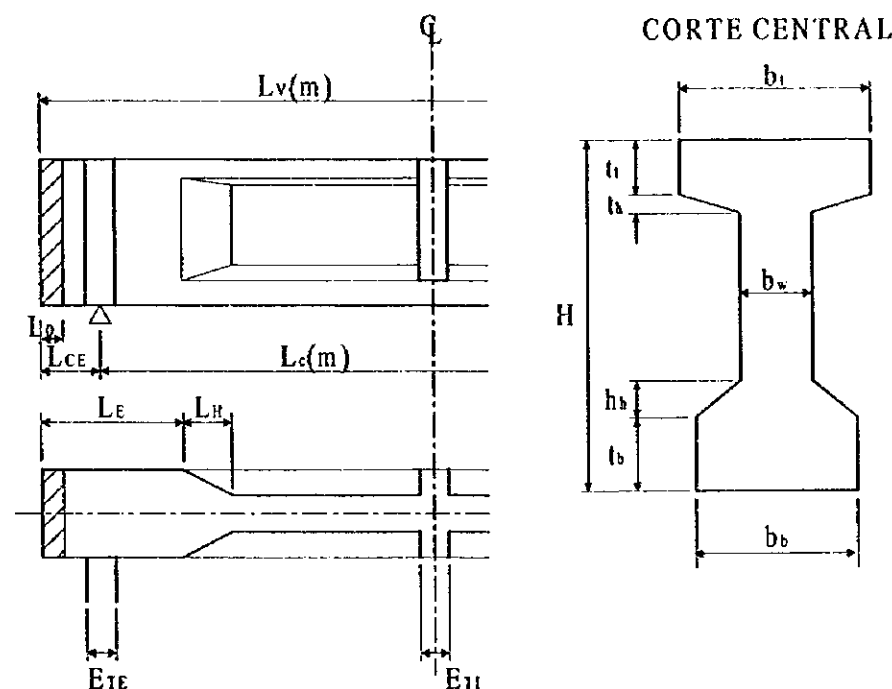

Longitud de Viga : $L_v = 25.950$ m , $L_{CE} = 0.350$ m , $L_0 = 100$ mm

$L_E = 1600$ mm , $L_{H} = 600$ mm , $E_{TE} = 300$ mm , $E_{TL} = 250$ mm

Altura de Viga : $H = 1.700$ m

$b_t = 1000$ mm , $t_t = 150$ mm , $t_b = 150$ mm , $b_w = 200$ mm

$h_b = 250$ mm , $t_b = 250$ mm , $b_b = 500$ mm

Coefficiente de rozamiento parásito : $K = 0.0045$

Coefficiente de rozamiento en curva : $\mu = 0.25$

Número de Travesaños(Intermedio) : 2

Separación entre Travesaño : 8.400 m

Ancho Mesa Mínimo : $W_m = 10.900$ m

Cuantificación del Postensado

(5) Diseño de Losa

E_M (cm)	E_L (cm)	d_{req} (cm)	d (cm)	A_{sreq} (cm ²)	A_s (cm ²)		
17.0	≤ 17.0	OK	13.3	≤ 14.0	OK	12.374 ≤ $\phi 16@150=13.407$	OK
ϕM_u (tm/m)	M_u (tm/m)	Distribución : A_s (cm ²)					
6.424	≥ 5.077	OK	67 (%) 8.291 ≤ $\phi 12@125=9.048$				OK

(6) Diseño de Viga

($x = l/2 = 12.625$ m)

	Exterior		Interior					
	Transferencial	Servicio	Transferencial	Servicio				
Fatiga (kg/cm ²)	Total f_t (kg/cm ²)	Total f_t (kg/cm ²)	Total f_t (kg/cm ²)	Total f_t (kg/cm ²)				
Viga Superior: f_{vs}	0 ≤ 168	OK	65 ≤ 140	OK	0 ≤ 168	OK	69 ≤ 140	OK
Viga Inferior: f_{vi}	126 ≤ 168	OK	-3 ≥ -15	OK	126 ≤ 168	OK	-12 ≥ -15	OK

($x = 9.076$ m) Interior

	Transferencial	Servicio		
	Total f_t (kg/cm ²)	Total f_t (kg/cm ²)		
Viga Superior: f_{vs}	-4 ≥ -13	OK	61 ≤ 140	OK
Viga Inferior: f_{vi}	132 ≤ 168	OK	2 ≤ 140	OK

A_p (cm ²)	A_s (cm ²)	ϕM_u (tm)	M_u (tm)	ϕM_u (tm)	$1.2M_u$ (tm)	
4x6.910 = 27.640	6- $\phi 12 = 6.786$	878.978	≥ 754.758	OK	878.978 ≥ 637.688	OK

(7) Verificación de Corte

$h/2 =$	0.850 m	$A_v = 6-\phi 12 = 6.786$ cm ²	$s = 20.0$ cm	$d_p = 90.0$ cm	
$V_u =$	112.895 t	≤ $\phi(V_c + V_s) = 0.9 \times (97.104 + 128.255) = 202.823$ t			OK
Cálculo de Conectores	$A_v = 4-\phi 12 = 4.524$ cm ²	$V_u = 112.895$ ≤ $\phi V_{pb} = 430.457$			OK

(8) Deflexión de Transferencia

δ_p (cm)	δ_t (cm)	$L_c/800$	
2.6	1.0	≤ 3.2	OK

(9) Cálculo de Travesaño

A_{sreq} (cm ²)	A_s (cm ²)	
12.812	≤ 14.908	OK

(10) Cálculo de Anclajes Antisísmicos

A_p (cm ²)	R_c (t)	
49.076 ≤ 4x3x $\phi 25=58.908$	OK	48.736

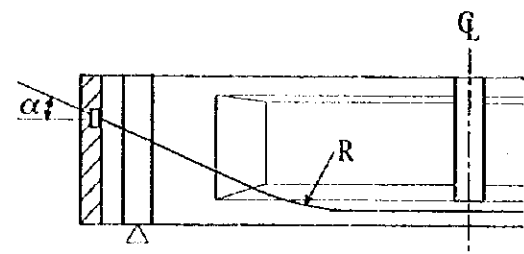

No.	α (deg)	R(m)
1	7.0	10.00
2	7.0	10.00
3	7.0	10.00
4	7.0	10.00
5	0.0	0.00
6	0.0	0.00
7	0.0	0.00

CORTE FINAL CORTE CENTRAL

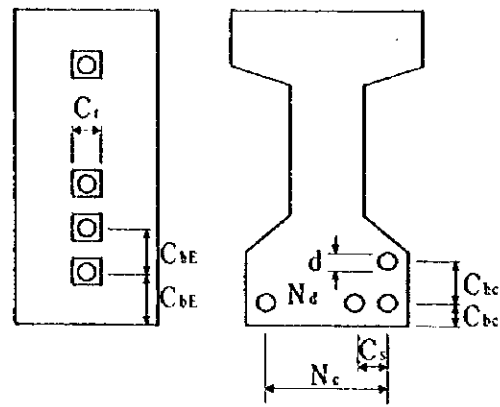

Número de ductos a descontar :

- $N_d = 4,$ $d = 80$ mm
- $N_c = 3,$ $C_s = 140$ mm
- $C_{bc} = 120$ mm, $C_{bc} = 90$ mm
- $C_t = 180$ mm
- $C_{be} = 320$ mm, $C_{be} = 320$ mm
- $C_{DC} = 12.0$ cm, $C_{DE} = 80.0$ cm

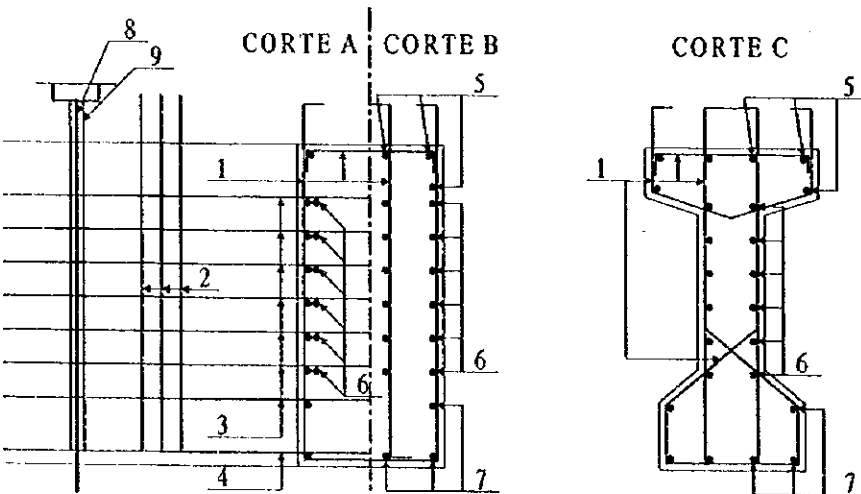
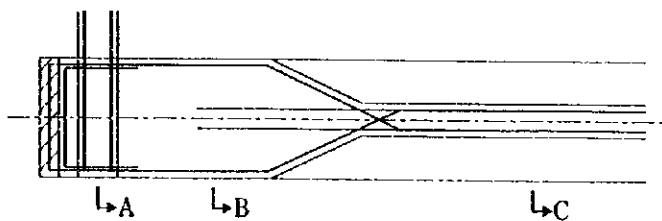

Recubrimientos mínimos : Viga 2.5 cm

- 1 : $\phi 12 @ 200,$ 2 : $\phi 12 @ 200,$ 3 : $\phi 18$ n 7, 4 : $\phi 25$
- 5 : $\phi 12,$ 6 : $\phi 10$ n 6, 7 : $\phi 12$
- 8 : $\phi 25$ n 3, 9 : $\phi 3$ "

Resultado del diseño

Tipo de Estructura : Estribo

Fecha :

(1) Datos Generales

Número de Puente:

Nombre del Puente : DAVID GARCIA A1

De la Ruta, Camino :

Rol Ruta:

En el Cauce :

Región V : VALPARAISO

Provincia :

Longitud del Puente : $L = 104.050$ m

Número de Pistas : 2

Ancho : $1.500 + 10.000 + 1.500 = 13.000$ m

(Pasillos) (Calzada) (Pasillos)

Pendiente : 1.0 , 1.5 , 1.0 %

(2) Cargas

Peso específico suelo : $\gamma_s = 2.00$ t/m³Carga de Hormigón : $w_c = 2.50$ t/m³Coeficiente de Aceleración de Diseño : $A = 0.15$ Longitud de Viga : $L_v = 25.950$ m , Luz : $L_c = 25.250$ m (Longitud de cálculo)Número de Vigas : $n_v = 5$ Separación entre vigas : $S = 2.600$ m , 4 @ 2.600 = 10.400 mAltura de Viga : $h = 1.700$ m , Ancho de Viga : $b_v = 50.0$ cmCarga de Superestructura : $R_v = 48.74$ t , Carga de Tránsito : HS20 - 44

(para 1 apoyo)

Carga de superficie : $Q_w = 1.00$ t/m² , Carga de Pavimento : $\gamma_c = 2.30$ t/m³

(3) Material

Hormigón : grado : H-30

 $f_c' = 250$ kg/cm² , $w_c = 145$ pcf = 2.32 kg/m³ (AASHTO 8.7.1) $E_c = w_c^{1.5} 33(f_c')^{1/2} = 57000(f_c')^{1/2}$ $= w_c^{1.5} (0.0428)(f_c')^{1/2} = 4729.77(f_c')^{1/2} = 2.5 \times 10^5$ kg/cm²Acero : A63-42H $f_y = 4200$ kg/cm² , $f_{sa} = 1690$ kg/cm² , $E_s = 2.1 \times 10^6$ kg/cm²Ángulo de fricción interna relleno : $\phi = 35$ degAdhesión entre dado y suelo de fundación : $c_B = 0.00$ t/m²Ángulo de fricción interna suelo de fundación : $\phi_B = 42$ degÁngulo de fricción entre dado y suelo de fundación : $\delta_B = 30$ deg

(4) Geometría

Longitud de Acceso : $I_0 = 4.000 \text{ m}$, Espesor de Acceso: $h_A = 0.250 \text{ m}$

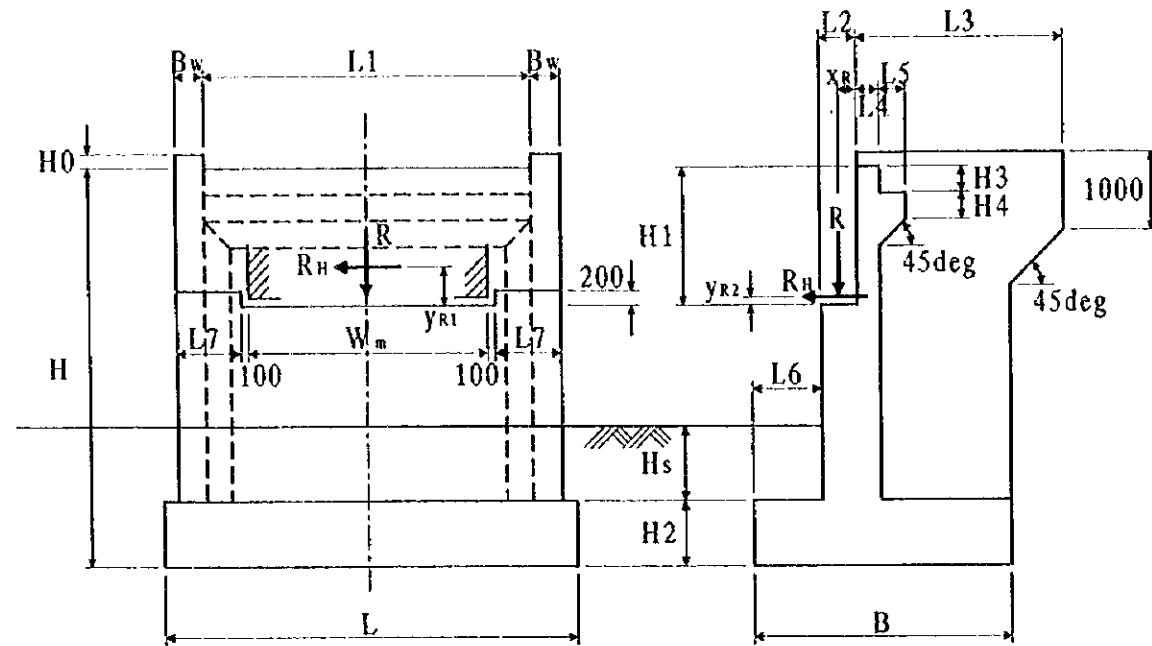

$B = 4300 \text{ mm}$, $L = 13500 \text{ mm}$, $H = 6000 \text{ mm}$, $H_s = 1000 \text{ mm}$, $W_m = 10900 \text{ mm}$
 $B_w = 450 \text{ mm}$, $y_{R1} = 1500 \text{ mm}$, $y_{R2} = 155 \text{ mm}$, $x_R = 400 \text{ mm}$
 $L1 = 12100 \text{ mm}$, $L2 = 800 \text{ mm}$, $L3 = 3500 \text{ mm}$, $L4 = 400 \text{ mm}$, $L5 = 250 \text{ mm}$
 $L6 = 1000 \text{ mm}$, $L7 = 950 \text{ mm}$
 $H0 = 250 \text{ mm}$, $H1 = 2150 \text{ mm}$, $H2 = 1000 \text{ mm}$, $H3 = 250 \text{ mm}$, $H4 = 250 \text{ mm}$

(5) Arriostamiento de Refuerzo

Recubrimientos mínimos : Fundación 5.0 cm

Elevación 4.0 cm

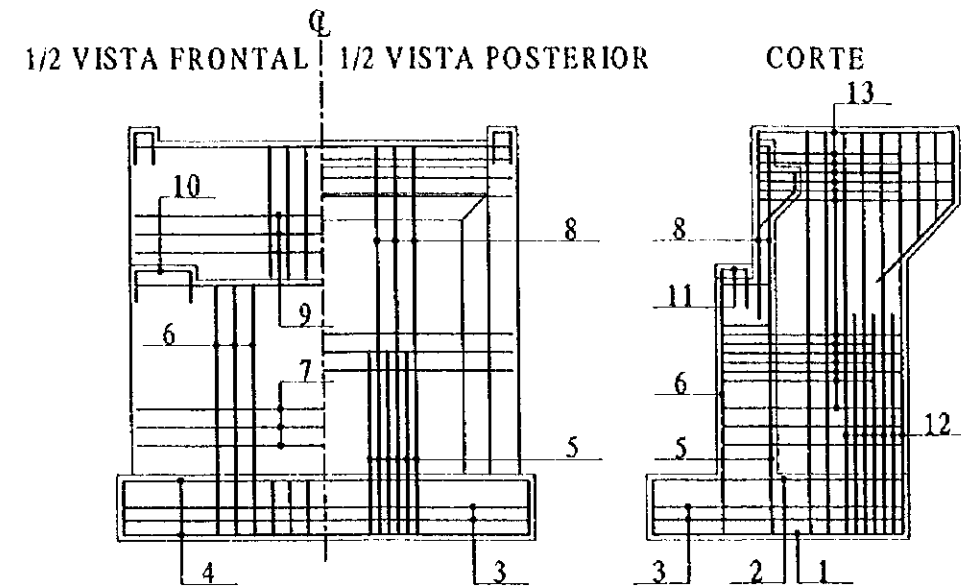

$1 : \phi 22 @ 250$ $2 : \phi 22 @ 125$ $3 : \phi 18 \text{ n } 3$ $4 : \phi 18 @ 250$ $5 : \phi 18 @ 125$
 $6 : \phi 18 @ 250$ $7 : \phi 16 @ 250$ $8 : \phi 18 @ 250$ $9 : \phi 12 @ 250$ $10 : \phi 18 \text{ n } 3$
 $11 : \phi 18 \text{ n } 4$ $12 : \phi 18 @ 125$ $13 : \phi 18 @ 200$

Suma del Diseño del Estribo

(7) Fuerzas

Caso	e (m)	
Estático	0.243 ≤ B/6 = 0.717	OK
Sísmico	1.418 ≤ B/3 = 1.433	OK

(8) Análisis de Estabilidad

Caso	F.S.(S)	q _{max} (t/m ²)	q _{ADM} (t/m ²)	F.S.(O)	
Estático	4.700 ≥ 1.5	21.77 ≤ 252.57		8.247 ≥ 2.0	OK
Sísmico	1.281 ≥ 1.2	57.07 ≤ 111.40		1.500 ≥ 1.5	OK

(9) Diseño del Muro de Retención

Diseño del refuerzo anterior (Caso estático)

A _s (cm ² /m)	M(tm/m)	M _s (tm/m)	
9.194 ≤ φ18@250=10.180	4.97 ≤ 13.47		OK

Diseño del refuerzo posterior (Caso sísmico)

A _s (cm ² /m)	M(tm/m)	M _s (tm/m)	v(kg/cm ²)	v _c (kg/cm ²)	
1.687 ≤ φ18@250=10.180	1.21 ≤ 13.47		0.4 ≤ 20.0		OK

(10) Diseño del guarda rueda

A _s (cm ²)	M(tm)	M _s (tm)	v(kg/cm ²)	v _c (kg/cm ²)	
3.014 ≤ φ18n3=7.635	5.48 ≤ 25.99		0.5 ≤ 20.0		OK

(11) Diseño del Cuerpo del Estribo

Caso	A _s (cm ² /m)	f _c (kg/cm ²)	f _s (kg/cm ²)	f _c (kg/cm ²)	f _s (kg/cm ²)
Estático	7.598 ≤ φ18@125	1.0 ≤ 100		22.0 ≤ 1690	
Sísmico	7.075 ≤ 20.360	1.2 ≤ 133		33.1 ≤ 2248	

Caso	v(kg/cm ²)	v _c (kg/cm ²)	
Estático	0.6 ≤ 15.0		OK
Sísmico	0.7 ≤ 20.0		OK

(12) Diseño de Fundaciones

Diseño del dado frontal

Caso	A _s (cm ² /m)	M(tm/m)	M _s (tm/m)	v(kg/cm ²)	v _c (kg/cm ²)	
Estático	6.449 ≤ φ22@250	9.21 ≤ 53.73		1.0 ≤ 15.0		OK
Sísmico	12.086 ≤ 15.204	22.95 ≤ 53.73		2.5 ≤ 20.0		OK

Diseño del dado trasero

Caso	A _s (cm ² /m)	M(tm/m)	M _s (tm/m)	v(kg/cm ²)	v _c (kg/cm ²)	
Estático	7.360 ≤ φ22@125	10.51 ≤ 105.74		0.7 ≤ 15.0		OK
Sísmico	16.825 ≤ 30.408	31.95 ≤ 105.74		2.4 ≤ 20.0		OK

(13) Diseño del Muro Ala

	Caso	A _s (cm ² /m)	M(tm/m)	M _s (tm/m)	v(kg/cm ²)	v _c (kg/cm ²)	
a	Estático	9.673 ≤ φ18@200	5.96 ≤ 19.12		1.2 ≤ 15.0		OK
	Sísmico	5.487 ≤ 12.725	4.50 ≤ 19.12		0.9 ≤ 20.0		OK
b	Estático	12.166 ≤ φ18@200	7.50 ≤ 19.12		1.7 ≤ 15.0		OK
	Sísmico	8.029 ≤ 12.725	6.58 ≤ 19.12		1.5 ≤ 20.0		OK
b'	Estático	3.981 ≤ φ18@400	2.45 ≤ 9.71		1.1 ≤ 15.0		OK
	Sísmico	2.714 ≤ 6.363	2.22 ≤ 9.71		1.0 ≤ 20.0		OK
c	Estático	14.671 ≤ φ18@125	9.04 ≤ 30.01		2.3 ≤ 15.0		OK
	Sísmico	9.913 ≤ 20.360	8.12 ≤ 30.01		2.1 ≤ 20.0		OK
c'	Estático	4.294 ≤ φ18@250	2.65 ≤ 15.39		1.3 ≤ 15.0		OK
	Sísmico	2.949 ≤ 10.180	2.42 ≤ 15.39		1.2 ≤ 20.0		OK
d	Estático	0.642 ≤ φ18@400	0.40 ≤ 9.71		0.2 ≤ 15.0		OK
	Sísmico	0.314 ≤ 6.363	0.26 ≤ 9.71		0.2 ≤ 20.0		OK

Resultado del diseño

Tipo de Estructura : Estribo

Fecha :

(1) Datos Generales

Número de Puente:

Nombre del Puente : DAVID GARCIA A2

De la Ruta, Camino :

Rol Ruta:

En el Cauce :

Región V : VALPARAISO

Provincia :

Longitud del Puente : L = 104.050 m

Número de Pistas : 2

Ancho : 1.500 + 10.000 + 1.500 = 13.000 m

(Pasillos) (Calzada) (Pasillos)

Pendiente : 1.0, 1.5, 1.0 %

(2) Cargas

Peso específico suelo : $\gamma_s = 2.00 \text{ t/m}^3$ Carga de Hormigón : $w_c = 2.50 \text{ t/m}^3$

Coeficiente de Aceleración de Diseño : A = 0.15

Longitud de Viga : $L_v = 25.950 \text{ m}$, Luz : $L_c = 25.250 \text{ m}$ (Longitud de cálculo)Número de Vigas : $n_v = 5$

Separación entre vigas : S = 2.600 m, 4 @ 2.600 = 10.400 m

Altura de Viga : h = 1.700 m, Ancho de Viga : $b_b = 50.0 \text{ cm}$ Carga de Superestructura : $R_v = 48.74 \text{ t}$, Carga de Tránsito : HS20 - 44

(para 1 apoyo)

Carga de superficie : $Q_w = 1.00 \text{ t/m}^2$, Carga de Pavimento : $\gamma_c = 2.30 \text{ t/m}^3$

(3) Material

Hormigón : grado : H-30

 $f_c' = 250 \text{ kg/cm}^2$, $w_c = 145 \text{ pcf} = 2.32 \text{ kg/m}^3$ (AASHTO 8.7.1) $E_c = w_c^{1.5} 33(f_c')^{1/2} = 57000(f_c')^{1/2}$ $= w_c^{1.5} (0.0428)(f_c')^{1/2} = 4729.77(f_c')^{1/2} = 2.5 \times 10^5 \text{ kg/cm}^2$ Acero : A63-42H $f_y = 4200 \text{ kg/cm}^2$, $f_{sa} = 1690 \text{ kg/cm}^2$, $E_s = 2.1 \times 10^6 \text{ kg/cm}^2$ Ángulo de fricción interna relleno : $\phi = 35 \text{ deg}$ Adhesión entre dado y suelo de fundación : $c_B = 0.00 \text{ t/m}^2$ Ángulo de fricción interna suelo de fundación : $\phi_B = 42 \text{ deg}$ Ángulo de fricción entre dado y suelo de fundación : $\delta_B = 30 \text{ deg}$

(4) Geometría

Longitud de Acceso : $I_0 = 4.000 \text{ m}$, Espesor de Acceso : $h_A = 0.250 \text{ m}$

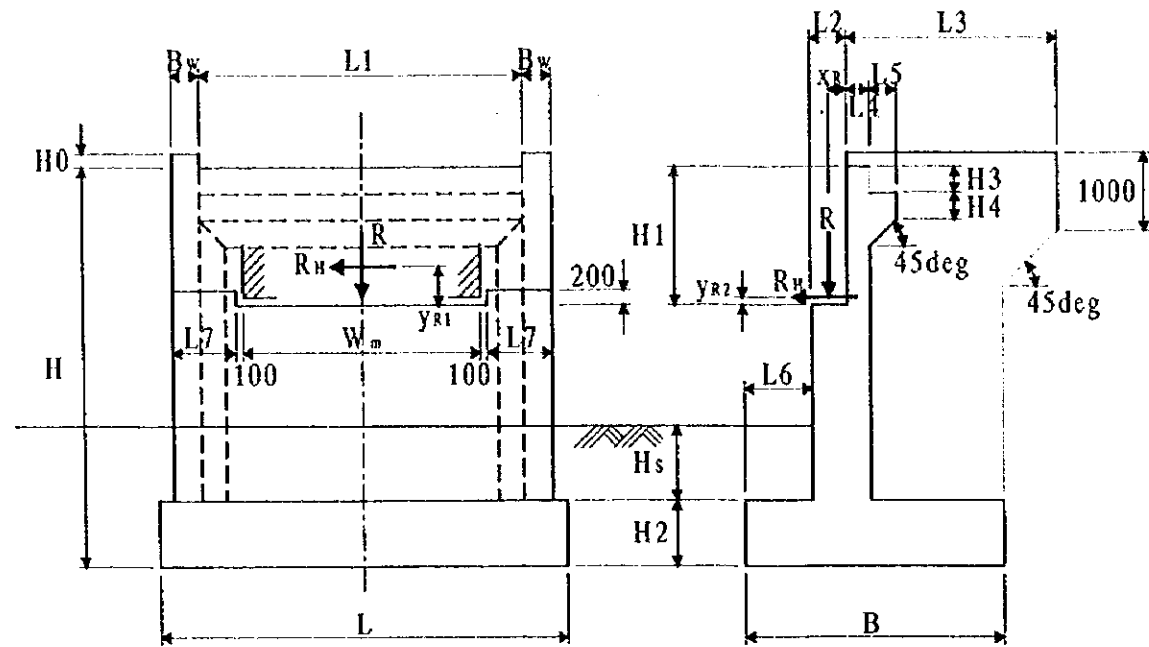

- $B = 5600 \text{ mm}$, $L = 13600 \text{ mm}$, $H = 9000 \text{ mm}$, $H_s = 2000 \text{ mm}$, $W_m = 10900 \text{ mm}$
 $B_w = 550 \text{ mm}$, $y_{R1} = 1500 \text{ mm}$, $y_{R2} = 155 \text{ mm}$, $x_R = 400 \text{ mm}$
 $L1 = 12100 \text{ mm}$, $L2 = 800 \text{ mm}$, $L3 = 4000 \text{ mm}$, $L4 = 400 \text{ mm}$, $L5 = 250 \text{ mm}$
 $L6 = 1700 \text{ mm}$, $L7 = 1050 \text{ mm}$
 $H0 = 250 \text{ mm}$, $H1 = 2150 \text{ mm}$, $H2 = 1800 \text{ mm}$, $H3 = 250 \text{ mm}$, $H4 = 250 \text{ mm}$

(5) Arriostamiento de Refuerzo

Recubrimientos mínimos : Fundación 5.0 cm
Elevación 4.0 cm

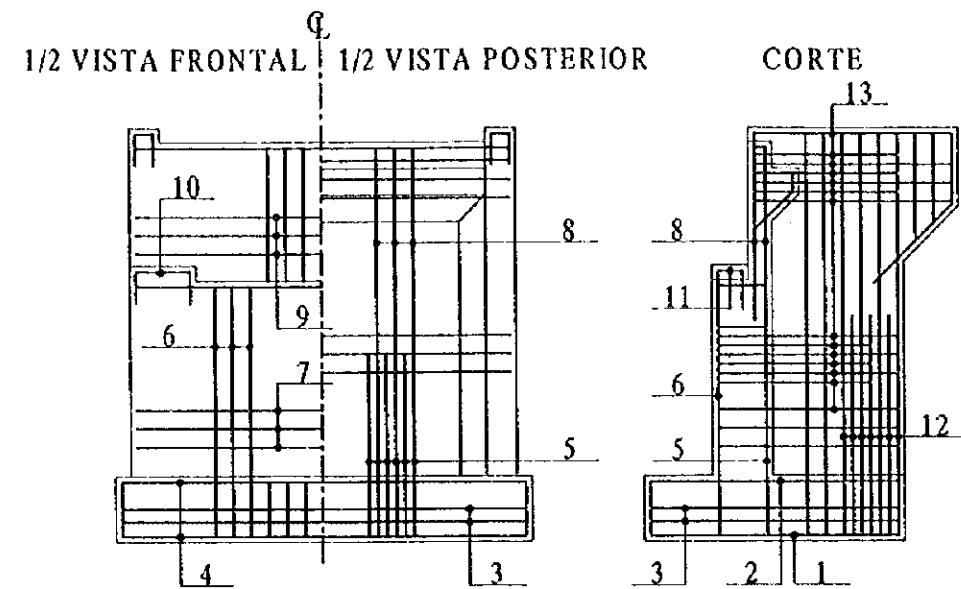

- 1 : $\phi 25 @ 250$ 2 : $\phi 25 @ 125$ 3 : $\phi 18 \text{ n } 3$ 4 : $\phi 18 @ 250$ 5 : $\phi 22 @ 125$
 6 : $\phi 22 @ 250$ 7 : $\phi 16 @ 250$ 8 : $\phi 18 @ 250$ 9 : $\phi 12 @ 250$ 10 : $\phi 18 \text{ n } 4$
 11 : $\phi 18 \text{ n } 4$ 12 : $\phi 25 @ 125$ 13 : $\phi 25 @ 200$

Suma del Diseño del Estribo

(7) Fuerzas

Caso	e (m)	
Estático	0.212 \leq B/6 = 0.933	OK
Sísmico	1.697 \leq B/3 = 1.867	OK

(8) Análisis de Estabilidad

Caso	F.S.(S)	$q_{max}(t/m^2)$	$q_{ADN}(t/m^2)$	F.S.(O)	
Estático	3.433 \geq 1.5	23.99 \leq 378.39		5.885 \geq 2.0	OK
Sísmico	1.346 \geq 1.2	61.39 \leq 209.45		1.542 \geq 1.5	OK

(9) Diseño del Muro de Retención

Diseño del refuerzo anterior (Caso estático)

$A_s(cm^2/m)$	M(tm/m)	$M_u(tm/m)$	
9.194 \leq $\phi 18@250=10.180$	4.97 \leq 13.47		OK

Diseño del refuerzo posterior (Caso sísmico)

$A_s(cm^2/m)$	M(tm/m)	$M_u(tm/m)$	$v(kg/cm^2)$	$v_c(kg/cm^2)$	
1.687 \leq $\phi 18@250=10.180$	1.21 \leq 13.47		0.4 \leq 20.0		OK

(10) Diseño del guarda rueda

$A_s(cm^2)$	M(tm)	$M_u(tm)$	$v(kg/cm^2)$	$v_c(kg/cm^2)$	
2.716 \leq $\phi 18n4=10.180$	5.48 \leq 38.38		0.5 \leq 20.0		OK

(11) Diseño del Cuerpo del Estribo

Caso	$A_s(cm^2/m)$	$f_c(kg/cm^2)$	$f_{cs}(kg/cm^2)$	$f_s(kg/cm^2)$	$f_{ss}(kg/cm^2)$
Estático	21.088 \leq $\phi 22@125$	2.4 \leq 100		64.8 \leq 1690	
Sísmico	20.253 \leq 30.408	3.0 \leq 133		89.8 \leq 2248	

Caso	$v(kg/cm^2)$	$v_c(kg/cm^2)$	
Estático	1.2 \leq 15.0		OK
Sísmico	1.4 \leq 20.0		OK

(12) Diseño de Fundaciones

Diseño del dado frontal

Caso	$A_s(cm^2/m)$	M(tm/m)	$M_u(tm/m)$	$v(kg/cm^2)$	$v_c(kg/cm^2)$	
Estático	10.214 \leq $\phi 25@250$	26.86 \leq 128.45		0.9 \leq 15.0		OK
Sísmico	19.157 \leq 19.636	67.01 \leq 128.45		2.3 \leq 20.0		OK

Diseño del dado trasero

Caso	$A_s(cm^2/m)$	M(tm/m)	$M_u(tm/m)$	$v(kg/cm^2)$	$v_c(kg/cm^2)$	
Estático	13.486 \leq $\phi 25@125$	35.47 \leq 254.02		1.0 \leq 15.0		OK
Sísmico	23.261 \leq 39.272	81.37 \leq 254.02		2.3 \leq 20.0		OK

(13) Diseño del Muro Ala

	Caso	$A_s(cm^2/m)$	M(tm/m)	$M_u(tm/m)$	$v(kg/cm^2)$	$v_c(kg/cm^2)$	
a	Estático	14.530 \leq $\phi 25@200$	11.14 \leq 45.07		1.5 \leq 15.0		OK
	Sísmico	9.156 \leq 24.545	9.33 \leq 45.07		1.3 \leq 20.0		OK
b	Estático	23.777 \leq $\phi 25@200$	18.23 \leq 45.07		2.6 \leq 15.0		OK
	Sísmico	16.458 \leq 24.545	16.78 \leq 45.07		2.4 \leq 20.0		OK
b'	Estático	7.549 \leq $\phi 25@400$	5.79 \leq 23.10		1.7 \leq 15.0		OK
	Sísmico	5.321 \leq 12.273	5.42 \leq 23.10		1.6 \leq 20.0		OK
c	Estático	28.056 \leq $\phi 25@125$	21.51 \leq 69.95		3.4 \leq 15.0		OK
	Sísmico	19.676 \leq 39.272	20.06 \leq 69.95		3.2 \leq 20.0		OK
c'	Estático	8.084 \leq $\phi 25@250$	6.20 \leq 36.41		1.9 \leq 15.0		OK
	Sísmico	5.723 \leq 19.636	5.83 \leq 36.41		1.8 \leq 20.0		OK
d	Estático	0.422 \leq $\phi 25@400$	0.32 \leq 23.10		0.2 \leq 15.0		OK
	Sísmico	0.209 \leq 12.273	0.21 \leq 23.10		0.1 \leq 20.0		OK

Resultado del diseño

Tipo de Estructura : Cepa

Fecha :

(1) Datos Generales

Nombre del Puente : DAVID GARCIA P1

De la Ruta, Camino :

En el Cauce :

Región : V : VALPARAISO

Provincia :

Longitud del Puente : L = 104.050 m

Número de Pistas : 2

Ancho : 1.500 + 10.000 + 1.500 = 13.000 m

(Pasillos) (Calzada) (Pasillos)

Pendiente : 1.0, 1.5, 1.0 %

(2) Cargas

Peso específico suelo : $\gamma_s = 2.00 \text{ t/m}^3$

Cargas de Hormigón : $w_c = 2.50 \text{ t/m}^3$

Coefficiente de Aceleración de Diseño : A = 0.15

Longitud de Viga : $L_v = 25.950 \text{ m}$, Luz : $L_c = 25.250 \text{ m}$ (Longitud de cálculo)

Número de Vigas : $n_v = 5$

Separación entre vigas : S = 2.600 m, 4 @ 2.600 = 10.400 m

Ancho de Viga : $b_b = 50.0 \text{ cm}$

Carga de Superestructura : $R_v = 48.74 \text{ t}$ (para 1 apoyo)

Cargas de Tránsito : HS20 - 44

Altura de la Superestructe : $H_v = 1.850 \text{ m}$

Carga de viento sobre Superestructura : $W_v = 0.244 \text{ t/m}^2$

Carga de viento sobre infraestructura : $W_E = 0.244 \text{ t/m}^2$

Velocidad del cauce : V = 2.000 m/s

(3) Material

Hormigón : H-30 $f'_c = 250 \text{ kg/cm}^2$, $w_c = 145 \text{ pcf} = 2.32 \text{ kg/m}^3$ (AASHTO 8.7.1)

$$E_c = w_c^{1.5} 33 (f'_c)^{1/2} = 57000 (f'_c)^{1/2}$$

$$= w_c^{1.5} (0.0428) (f'_c)^{1/2} = 4729.77 (f'_c)^{1/2} = 2.5 \times 10^5 \text{ kg/cm}^2$$

Acero : A63-42H $f_y = 4200 \text{ kg/cm}^2$, $f_u = 1690 \text{ kg/cm}^2$, $E_s = 2.1 \times 10^6 \text{ kg/cm}^2$

Adhesión entre dado y suelo de fundación : $c_B = 0.00 \text{ t/m}^2$

Ángulo de fricción interna suelo de fundación : $\phi_B = 42 \text{ deg}$

Ángulo de fricción entre dado y suelo de fundación : $\delta_B = 30 \text{ deg}$

(4) Geometría

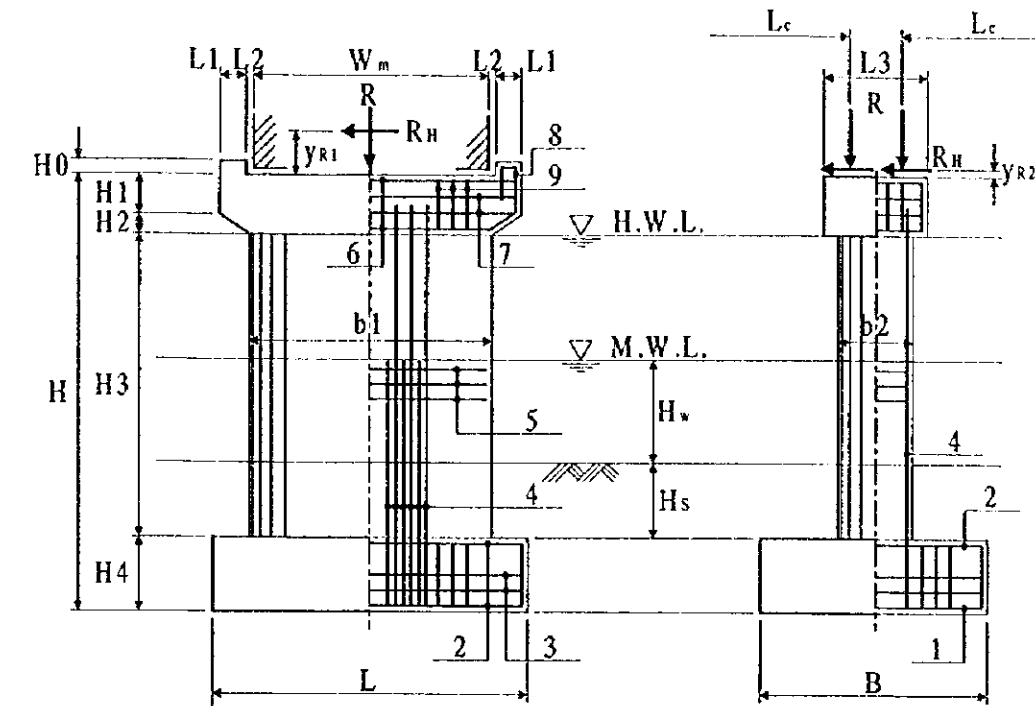

B = 6600 mm, L = 11500 mm, H = 7500 mm, $H_s = 1500 \text{ mm}$, $H_w = 1000 \text{ mm}$
 $y_{R1} = 1500 \text{ mm}$, $y_{R2} = 155 \text{ mm}$, L1 = 500 mm, L2 = 100 mm, L3 = 1800 mm
 $b1 = 11000 \text{ mm}$, $b2 = 1000 \text{ mm}$, $W_m = 10900 \text{ mm}$, $H0 = 300 \text{ mm}$
 $H1 = 500 \text{ mm}$, $H2 = 200 \text{ mm}$, $H3 = 5200 \text{ mm}$, $H4 = 1600 \text{ mm}$

Arriostamiento de Refuerzo

Recubrimientos mínimos : Fundación 5.0 cm

Elevación 4.0 cm

1 : $\phi 25 @ 125$, 2 : $\phi 25 @ 250$, 3 : $\phi 22 \text{ n } 4$, 4 : $\phi 25 @ 120$

5 : $\phi 22 @ 300$, 6 : $\phi 22 \text{ n } 4$, 7 : $\phi 22 \text{ n } 2$, 8 : $\phi 25 \text{ n } 8$

9 : $\phi 16 @ 250$

Suma del Diseño de la Cepa

(6) Fuerzas

Longitudinal :

Caso	e_B (m)	
Sísmico	2.176 $\leq B/3 = 2.200$	OK

Transversal :

Caso	e_L (m)	
Estático	0.116 $\leq L/6 = 1.917$	OK
Sísmico	2.364 $\leq L/3 = 3.833$	OK

(7) Análisis de Estabilidad

Longitudinal :

Caso	F.S.(S)	q_{max} (t/m ²)	q_{min} (t/m ²)	F.S.(O)	
Estático		23.71 \leq	531.28		OK
Sísmico	1.865 ≥ 1.2	47.44 \leq	245.03	1.517 ≥ 1.5	OK

Transversal :

Caso	F.S.(S)	q_{max} (t/m ²)	q_{min} (t/m ²)	F.S.(O)	
Estático	43.899 ≥ 1.5	13.46 \leq	518.61	49.744 ≥ 2.0	OK
Sísmico	1.864 ≥ 1.2	27.43 \leq	409.80	2.433 ≥ 1.5	OK

(8) Diseño del guarda rueda

A_s (cm ²)	M (tm)	M_u (tm)	v (kg/cm ²)	v_u (kg/cm ²)	
29.816 $\leq \phi 25 \text{ n } 8 = 39.272$	27.42 \leq	65.09	11.0 \leq	20.0	OK

(9) Diseño de la cepa

A_s (cm ²)	f_c (kg/cm ²)	f_{cu} (kg/cm ²)	f_t (kg/cm ²)	f_{tu} (kg/cm ²)
404.492 $\leq \phi 25 @ 120 = 417.265$	64.6 \leq	133	1675.5 \leq	2248

v (kg/cm ²)	v_u (kg/cm ²)	
1.4 \leq	20.0	OK

(10) Diseño de Fundaciones

Caso	A_s (cm ² /m)	M (tm/m)	M_u (tm/m)	v (kg/cm ²)	v_u (kg/cm ²)	
Estático	33.168 $\leq \phi 25 @ 125 = 39.272$	77.27 \leq	224.33	2.5 \leq	15.0	OK
Sísmico	38.343 $\leq \phi 25 @ 125 = 39.272$	118.80 \leq	224.33	3.8 \leq	20.0	OK

Resultado del diseño

Tipo de Estructura : Cepa

Fecha :

(1) Datos Generales

Nombre del Puente : DAVID GARCIA P2,P3
 De la Ruta, Camino :
 En el Cauce :
 Región : V : VALPARAISO
 Provincia :
 Longitud del Puente : L = 104.050 m
 Número de Pistas : 2
 Ancho : 1.500 + 10.000 + 1.500 = 13.000 m
 (Pasillos) (Calzada) (Pasillos)
 Pendiente : 1.0, 1.5, 1.0 %

Número de Puente :

Rol Ruta :

(2) Cargas

Peso específico suelo : $\gamma_s = 2.00 \text{ t/m}^3$
 Cargas de Hormigón : $w_c = 2.50 \text{ t/m}^3$
 Coeficiente de Aceleración de Diseño : $A = 0.15$
 Longitud de Viga : $L_v = 25.950 \text{ m}$, Luz : $L_c = 25.250 \text{ m}$ (Longitud de cálculo)
 Número de Vigas : $n_v = 5$
 Separación entre vigas : $S = 2.600 \text{ m}$, $4 @ 2.600 = 10.400 \text{ m}$
 Ancho de Viga : $b_v = 50.0 \text{ cm}$
 Carga de Superestructura : $R_v = 48.74 \text{ t}$ (para 1 apoyo)
 Cargas de Tránsito : HS20 - 44
 Altura de la Superestructura : $H_v = 1.850 \text{ m}$
 Carga de viento sobre Superestructura : $W_v = 0.244 \text{ t/m}^2$
 Carga de viento sobre infraestructura : $W_e = 0.244 \text{ t/m}^2$
 Velocidad del cauce : $V = 2.000 \text{ m/s}$

(3) Material

Hormigón : H-30 $f'_c = 250 \text{ kg/cm}^2$, $w_c = 145 \text{ pcf} = 2.32 \text{ kg/m}^3$ (AASHTO 8.7.1)
 $E_c = w_c^{1.5} 33(f'_c)^{1/2} = 57000(f'_c)^{1/2}$
 $= w_c^{1.5} (0.0428)(f'_c)^{1/2} = 4729.77(f'_c)^{1/2} = 2.5 \times 10^5 \text{ kg/cm}^2$
 Acero : A63-42H $f_y = 4200 \text{ kg/cm}^2$, $f_{sa} = 1690 \text{ kg/cm}^2$, $E_s = 2.1 \times 10^6 \text{ kg/cm}^2$
 Adhesión entre dado y suelo de fundación : $c_B = 0.00 \text{ t/m}^2$
 Ángulo de fricción interna suelo de fundación : $\phi_B = 42 \text{ deg}$
 Ángulo de fricción entre dado y suelo de fundación : $\delta_B = 30 \text{ deg}$

(4) Geometría

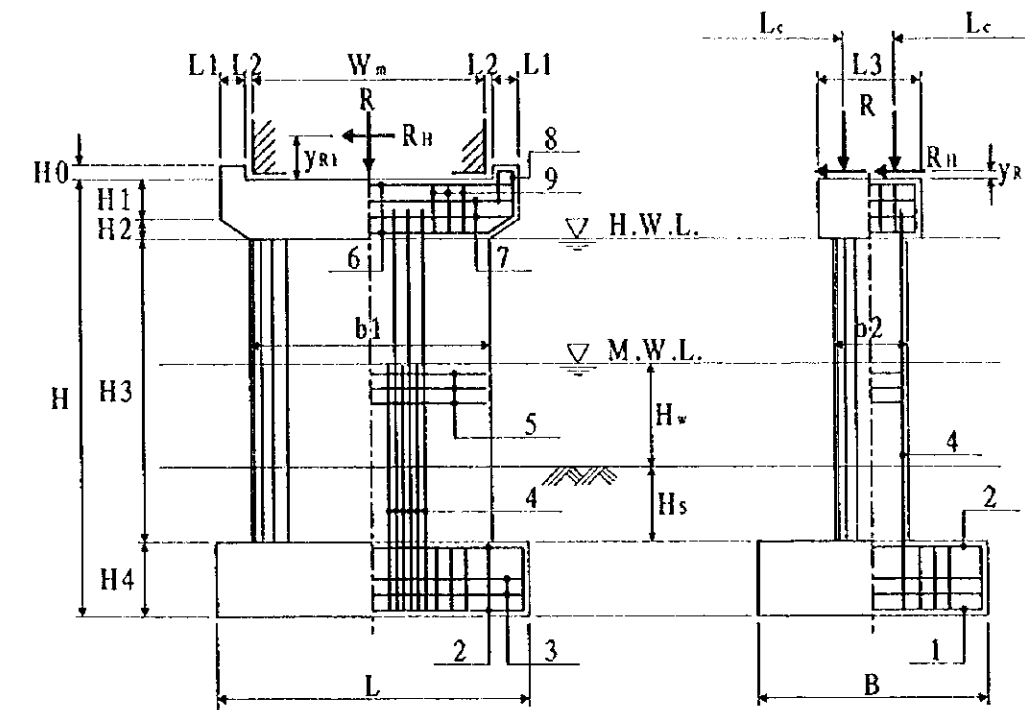

$B = 7000 \text{ mm}$, $L = 11500 \text{ mm}$, $H = 8500 \text{ mm}$, $H_s = 1500 \text{ mm}$, $H_w = 1000 \text{ mm}$
 $y_{R1} = 1500 \text{ mm}$, $y_{R2} = 155 \text{ mm}$, $L1 = 500 \text{ mm}$, $L2 = 100 \text{ mm}$, $L3 = 1800 \text{ mm}$
 $b1 = 11000 \text{ mm}$, $b2 = 1000 \text{ mm}$, $W_m = 10900 \text{ mm}$, $H0 = 300 \text{ mm}$
 $H1 = 500 \text{ mm}$, $H2 = 200 \text{ mm}$, $H3 = 6000 \text{ mm}$, $H4 = 1800 \text{ mm}$

Arriostramiento de Refuerzo

Recubrimientos mínimos : Fundación 5.0 cm
 Elevación 4.0 cm

1 : $\phi 25 @ 125$, 2 : $\phi 25 @ 250$, 3 : $\phi 22 \text{ n } 4$, 4 : $\phi 25 @ 100$
 5 : $\phi 22 @ 300$, 6 : $\phi 22 \text{ n } 2$, 7 : $\phi 22 \text{ n } 2$, 8 : $\phi 22 \text{ n } 8$
 9 : $\phi 16 @ 250$

Suma del Diseño de la Cepa

(6) Fuerzas

Longitudinal :

Caso	e_B (m)	
Sísmico	2.308 $\leq B/3 = 2.333$	OK

Transversal :

Caso	e_L (m)	
Estático	0.122 $\leq L/6 = 1.917$	OK
Sísmico	2.483 $\leq L/3 = 3.833$	OK

(7) Análisis de Estabilidad

Longitudinal :

Caso	F.S.(S)	$q_{max}(t/m^2)$	$q_{min}(t/m^2)$	F.S.(O)	
Estático		23.52 \leq	565.36		OK
Sísmico	1.941 ≥ 1.2	47.81 \leq	294.46	1.517 ≥ 1.5	OK

Transversal :

Caso	F.S.(S)	$q_{max}(t/m^2)$	$q_{min}(t/m^2)$	F.S.(O)	
Estático	45.995 ≥ 1.5	13.46 \leq	552.52	47.018 ≥ 2.0	OK
Sísmico	1.940 ≥ 1.2	28.67 \leq	439.15	2.316 ≥ 1.5	OK

(8) Diseño del guarda rueda

A_s (cm ²)	M(tm)	M_u (tm)	v (kg/cm ²)	v_c (kg/cm ²)	
29.816 $\leq \phi 22 n 8 = 30.408$	27.42 \leq	50.95	11.0 \leq	20.0	OK

(9) Diseño de la cepa

A_s (cm ²)	f_c (kg/cm ²)	f_{cs} (kg/cm ²)	f_t (kg/cm ²)	f_{ts} (kg/cm ²)
461.752 $\leq \phi 25@100 = 495.809$	67.3 \leq	133	1616.8 \leq	2248

v (kg/cm ²)	v_c (kg/cm ²)	
1.4 \leq	20.0	OK

(10) Diseño de Fundaciones

Caso	A_s (cm ² /m)	M(tm/m)	M_u (tm/m)	v (kg/cm ²)	v_c (kg/cm ²)	
Estático	32.549 $\leq \phi 25@125 = 39.272$	85.61 \leq	254.02	2.3 \leq	15.0	OK
Sísmico	38.518 $\leq \phi 25@125 = 39.272$	134.74 \leq	254.02	3.5 \leq	20.0	OK

RESUMEN DE CUBICACIONES
Puente N° 1

Nombre del Puente: David Garcia

Superestructura

Material (Ítem de Construcción)	Grado	Unidad	Cantidades					Comentarios	
			A1	P1	P2	P3	A2		Total
Superestructura									
Hormigón	H-25	m ³						116.2	Losa, Viga Travesaño
	H-35	m ³						87.8	Viga
Acero	A63-42H	kg						30,380.6	
	A44-28H	kg						848.5	Viga Travesaño
PC Cable	ASTM416-80	m						516.6	
Accesorios		n°						40.0	
Moldaje		m ²						981.8	Losa, Viga travesaño, Viga
Andamios		m ²						1,300.0	Para Losa de Hormigón
Zapata		n°	5.0	10.0	10.0	10.0	5.0	40.0	
Cantonera		m	10.4				10.4	20.8	
Baranda		m						68.0	
Drenaje		n°							
Pasillo		m ²						40.8	
Pavimento		m ²						353.6	

Losa de Acceso

Material (Ítem de Construcción)	Grado	Unidad	Cantidades					Comentarios	
			A1	P1	P2	P3	A2		Total
Hormigón	H-25	m ³	10.0				10.0	20.0	
Acero	A44-28	kg	457.9				457.9	915.8	
Moldaje		m ²	4.5				4.5	9.0	

Infraestructura y otros

Material (Ítem de Construcción)	Grado	Unidad	Cantidades					Comentarios	
			A1	P1	P2	P3	A2		Total
Infraestructura									
Hormigón	H-25	m ³	254.1	386.2	450.4	450.4	508.6	2,049.7	
Acero	A63-42H	kg	16,500.6	16,899.1	35,354.0	35,354.0	30,076.4	134,184.1	
Moldaje		m ²	454.7	419.7	474.1	474.1	722.6	2,545.2	
Excavación		m ³	302.4	507.5	507.5	507.5	504.0	2,328.9	
Horm. Emplant.		m ³	5.7	8.4	9.0	9.0	8.4	40.5	
Andamios		m ³	130.7	153.6	186.2	186.2	303.0	959.7	

Camino de Acceso

Material (Ítem de Construcción)	Grado	Unidad	Cantidades					Comentarios	
			A1	P1	P2	P3	A2		Total
Terraplén		m ³	145.0				240.0	385.0	
Base		m ³	40.0				40.0	80.0	
Pavimento		m ²	200.0				200.0	400.0	

Cubicaciones

Fecha : _____ Número de Puente : _____
 Nombre del Puente : DAVID GARCIA
 De la Ruta, Camino : _____ Rol Ruta : _____
 En el Cauce : _____
 Región : V : VALPARAISO Provincia : _____
 Longitud del Puente : L = 104.05 m
 Número de Pistas : 2
 Ancho : 1.50+10.00+1.50 = 13.00 m
 Pendiente : 1.0% (Pasillos) 1.5% (Calzada)
 Tipo de Estructura : **Postensado**
 Longitud de Viga : Lv = 25.95 m
 Luz : Lc = 25.25 m
 Número de Vigas : n_v = 5
 Separación entre Vigas : S = 2.60 m
 Ancho Mesa Mfñima : Wm = 11.40 m

Materia	Grado	Unidad	Cantidad		Observación
			(Para 1 Viga)	(Para Puente)	
Losa					
Hormigón	H-25	m ³	-----	101.73	
Moldaje		m ²	-----	273.66	
Acero	A63-42H	kg	-----	20,287.85	
Travesaño Intermedio					
Hormigón	H-25	m ³	-----	6.53	
Moldaje		m ²	-----	56.40	
Acero	A44-28H	kg	-----	848.53	
Travesaño Extremos					
Hormigón	H-25	m ³	-----	7.95	
Moldaje		m ²	-----	58.03	
Acero	A63-42H	kg	-----	1,220.64	
Viga			Exterior	Interior	
Hormigón	H-35	m ³	17.55	17.55	87.75
Moldaje		m ²	118.73	118.73	593.66
Acero	A63-42H	kg	1,703.32	1,821.82	8,872.08
PC Cable	ASTMA416-80	m	103.32	103.32	516.60
Anclaje		grupo	8	8	40

Tipo de Barras para hormigón

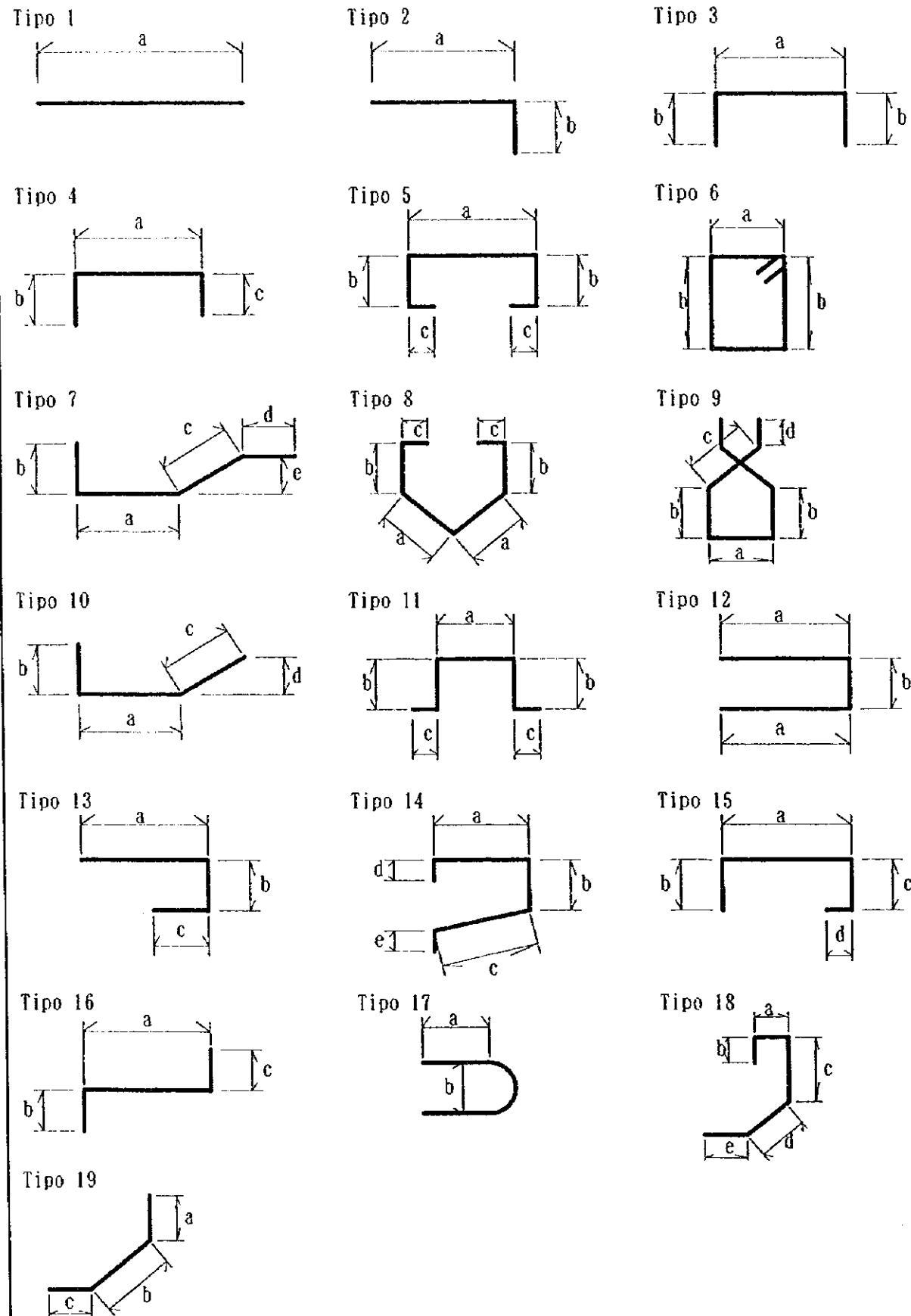

Marca	Dia. (mm)	Unit W. (kg/m)	Tipo	Dimensiones (mm)					Largos (mm)	Peso/Par. (kg)	Cant. Requ.	Peso Total (kg)	Obs.
				a	b	c	d	e					
1	16	1.578	1	12940					12940	20.42	176	3,593.80	
2	16	1.578	1	10700					10700	16.88	173	2,921.04	
3	16	1.578	3	12940	110				13160	20.77	174	3,613.37	
4	16	1.578	7	1920	110	156	150	110	2336	3.69	346	1,275.43	
5	16	1.578	20	1300	110	156	150		1912	3.02	519	1,565.89	
6	16	1.578	6	140	409				1337	2.11	348	734.21	
7	16	1.578	14	346	96	354	136	136	1067	1.68	348	585.94	
8	16	1.578	2	770	210				980	1.55	40	61.86	
9	16	1.578	1	1600					1600	2.52	80	201.98	
10	12	0.888	3	25890	360				26610	23.63	111	2,622.89	
11	12	0.888	1	25890					25890	22.99	8	183.92	
12	12	0.888	1	25890					25890	22.99	111	2,551.93	
13	12	0.888	1	1210					1210	1.07	218	234.24	
14	12	0.888	7	1466	102	665	180	210	2412	2.14	66	141.36	
15	18	1.998	1	2100					2100	4.20	96	402.80	
16	25	3.853	1	2100					2100	8.09	16	129.46	
17	12	0.888	6	200	1565				3710	3.29	96	316.27	
18	18	1.998	1	2100					2100	4.20	112	469.93	
19	25	3.853	1	2100					2100	8.09	16	129.46	
20	12	0.888	6	250	1815				4310	3.83	96	367.42	
21	12	0.888	3	25900	180				26260	23.32	30	699.57	
22	12	0.888	3	25900	180				26260	23.32	50	1,165.94	
23	10	0.617	1	23850					23850	14.72	60	882.93	
24	10	0.617	10	1572	450	1237	300		3259	2.01	120	241.30	
25	10	0.617	3	950	400				1750	1.08	60	64.79	
26	12	0.888	11	1815	150	102			2319	2.06	645	1,328.23	
27	12	0.888	9	450	219	584	180		2413	2.14	565	1,210.65	
28	12	0.888	8	508	273	102			1764	1.57	645	1,010.35	
29	12	0.888	5	300	1815	102			4134	3.67	20	73.42	Var
30	12	0.888	5	450	1650	102			3954	3.51	80	280.89	
31	12	0.888	3	950	102				1154	1.02	645	660.97	
32	12	0.888	3	1650	180				2010	1.78	20	35.70	
33	12	0.888	2	1650	75				1725	1.53	40	61.27	
34	18	1.998	1	1940					1940	3.88	72	279.08	
35	25	3.853	1	2500					2500	9.63	12	115.59	
36	18	1.998	1	1045					1045	2.09	48	100.22	
37	25	3.853	1	1325					1325	5.11	8	40.84	
38	18	1.998	1	1940					1940	3.88	84	325.59	
39	25	3.853	1	2500					2500	9.63	12	115.59	
40	18	1.998	1	1195					1195	2.39	56	133.71	
41	25	3.853	1	1475					1475	5.68	8	45.47	
42	25	3.853	1	2745					2745	10.58	24	253.84	

Cubicaciones

Fecha : _____ Número de Puente : _____
 Nombre del Puente : DAVID GARCIA A1
 De la Ruta, Camino : _____ Rol Ruta : _____
 En el Cauce : _____
 Región : V: VALPARAISO Provincia : _____

Longitud del Puente : L = 104.05 m
 Número de Pistas : 2
 Ancho : 1.50+10.00+1.50 = 13.00 m
 Pendiente : 1.0% (Pasillos) 1.5% (Calzada)
 Tipo de Estructura : **Estribo**
 Altura de Estribo : H = 6.00 m
 Longitud de Viga : Lv = 25.95 m
 Luz : Lc = 25.25 m
 Número de Vigas : nv = 5.00
 Separación entre Vigas : S = 2.60 m
 Ancho Mesa Mínima : Wm = 10.90 m

Materia	Grado	Unidad	Cantidad	Observación
Espaldar				
Hormigón	H-25	m ³	12.46	
Moldaje		m ²	57.23	
Acero	A63-42H	kg	1,029.64	
Muro				
Hormigón	H-25	m ³	44.92	
Moldaje		m ²	77.97	
Acero	A63-42H	kg	2,060.40	
Fundación				
Hormigón	H-25	m ³	58.05	
Moldaje		m ²	35.60	
Acero	A63-42H	kg	4,153.83	
Muros				
Hormigón	H-25	m ³	11.64	
Moldaje		m ²	56.54	
Acero	A63-42H	kg	1,006.44	
Total				
Hormigón	H-25	m³	127.06	
Moldaje		m²	227.35	
Acero	A63-42H	kg	8,250.31	

Tipo de Barras para hormigón

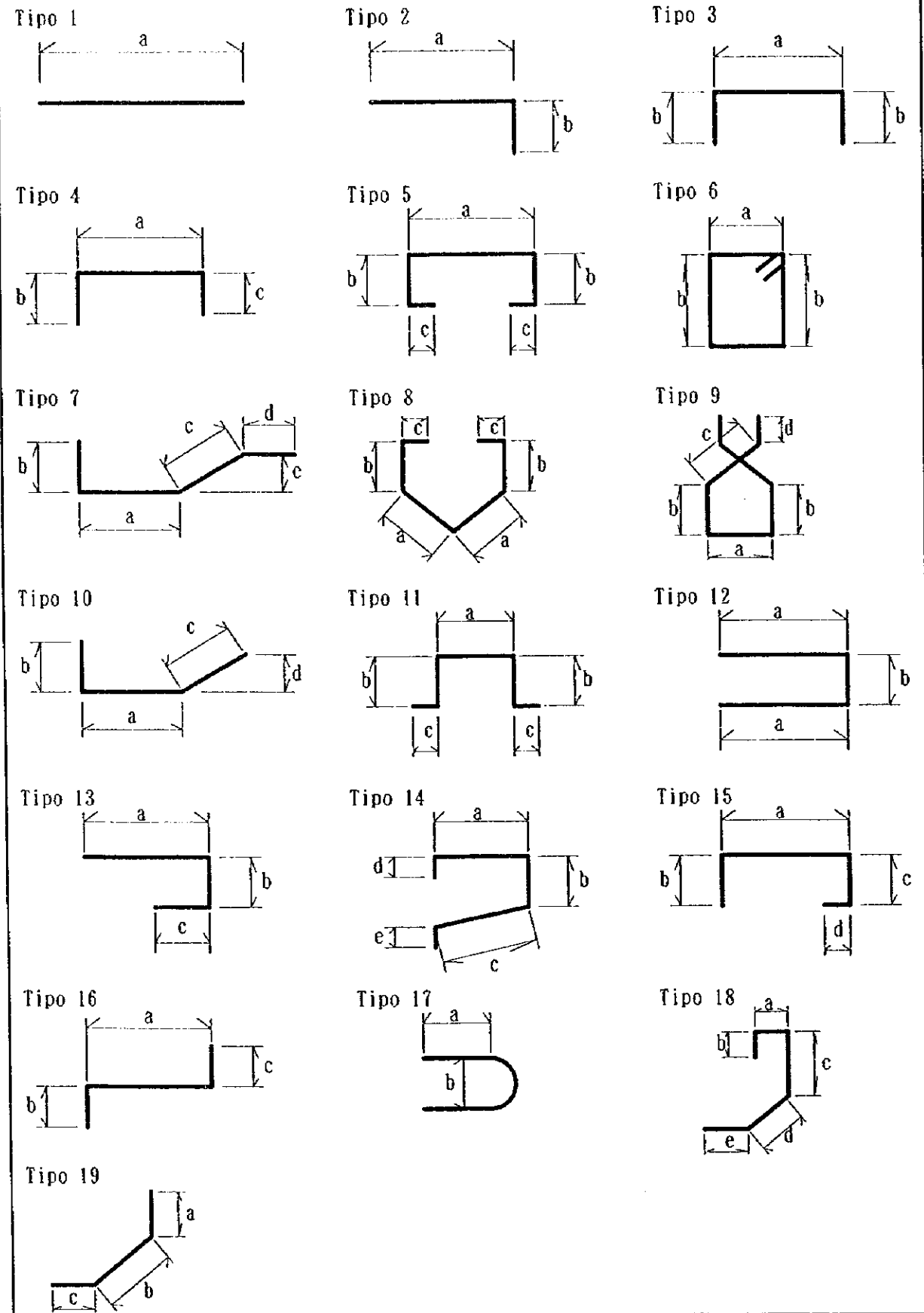

Marca	Dia. (mm)	Unit W. (kg/m)	Tipo	Dimensiones (mm)					Largos (mm)	Peso/Par. (kg)	Cant. Requi.	Peso Total (kg)	Obs.
				a	b	c	d	e					
1	22	2.984	3	4200	900				6000	17.90	55	984.72	
2	22	2.984	3	4200	770				5740	17.13	109	1,866.97	
3	18	1.998	3	13400	900				15200	30.37	18	546.65	
4	18	1.998	3	13400	630				14660	29.29	18	527.23	
5	18	1.998	3	13400	360				14120	28.21	6	169.27	
6	18	1.998	3	4200	360				4920	9.83	6	58.98	
7	16	1.578	1	12920					12920	20.39	14	285.43	
8	16	1.578	1	12920					12920	20.39	14	285.43	
9	18	1.998	2	3760	270				4030	8.05	53	426.75	
10	18	1.998	2	2735	270				3005	6.00	52	312.21	
11	18	1.998	2	3760	270				4030	8.05	53	426.75	
12	16	1.578	3	12920	240				13400	21.15	6	126.87	
13	18	1.998	3	1120	270				1660	3.32	44	145.93	
14	18	1.998	3	870	520				1910	3.82	6	22.90	
15	18	1.998	3	720	520				1760	3.52	8	28.13	
16	12	0.888	1	12920					12920	11.47	9	103.26	
17	18	1.998	1	2740					2740	5.47	53	290.15	
18	12	0.888	1	12920					12920	11.47	6	68.84	
19	18	1.998	1	2740					2740	5.47	53	290.15	
20	12	0.888	1	12920					12920	11.47	3	34.42	
21	18	1.998	14	570	194	807	270	153	1993	3.98	48	191.14	
22	12	0.888	1	12920					12920	11.47	2	22.95	
23	12	0.888	3	370	390				1150	1.02	4	4.08	
24	12	0.888	3	320	102				524	0.47	53	24.66	
25	18	1.998	2	3220	270				3490	6.97	16	111.57	
26	18	1.998	2	2420	270				2690	5.37	4	21.50	
27	18	1.998	2	3020	270				3290	6.57	4	26.29	Var
28	18	1.998	2	3420	270				3690	7.37	8	58.98	
29	18	1.998	2	2570	270				2840	5.67	10	56.74	
30	18	1.998	2	2420	270				2690	5.37	10	53.75	
31	18	1.998	2	2360	270				2630	5.25	10	52.55	
32	18	1.998	2	6160	270				6430	12.85	18	231.25	
33	12	0.888	3	370	1444				3257	2.89	6	17.35	Var
34	12	0.888	10	944	180	1655	1170		2778	2.47	4	9.87	
35	12	0.888	2	3220	180				3400	3.02	16	48.31	
36	12	0.888	2	2420	180				2600	2.31	4	9.24	
37	12	0.888	2	3020	180				3200	2.84	4	11.37	Var
38	12	0.888	2	3420	180				3600	3.20	8	25.57	
39	12	0.888	2	6160	180				6340	5.63	18	101.34	
40	12	0.888	2	3760	180				3940	3.50	8	27.99	
41	18	1.998	2	2494	270				2764	5.52	16	88.36	
42	18	1.998	2	1363	270				1633	3.26	10	32.63	
43	12	0.888	2	370	102				472	0.42	24	10.06	
44	12	0.888	2	370	102				472	0.42	28	11.74	

Cubicaciones

Fecha : _____ Número de Puente : _____

Nombre del Puente : DAVID GARCIA PI

De la Ruta, Camino : _____ Rol Ruta : _____

En el Cauce : _____

Región : V: VALPARAISO Provincia : _____

Longitud del Puente : L = 104.05 m

Número de Pistas : 2

Ancho : 1.50+10.00+1.50 = 13.00 m

Pendiente : 1.0% (Pasillos) 1.5% (Calzada)

Tipo de Estructura : Cepa

Altura de Cepa : H = 7.50 m

Longitud de Viga : Lv = 25.95 m

Luz : Lc = 25.25 m

Número de Vigas : n_v = 5.00

Separación entre Vigas : S = 2.60 m

Ancho Mesa Mínima : Wm = 10.90 m

Materia	Grado	Unidad	Cantidad	Observación
Cabezal				
Hormigón	H-25	m ³	15.59	
Moldaje		m ²	31.60	
Acero	A63-42H	kg	911.77	
Columna				
Hormigón	H-25	m ³	56.08	
Moldaje		m ²	120.34	
Acero	A63-42H	kg	6214.30	
Fundación				
Hormigón	H-25	m ³	121.44	
Moldaje		m ²	57.92	
Acero	A63-42H	kg	8233.50	
Total				
Hormigón	H-25	m ³	193.11	
Moldaje		m ²	209.86	
Acero	A63-42H	kg	15359.57	

Tipo de Barras para hormigón

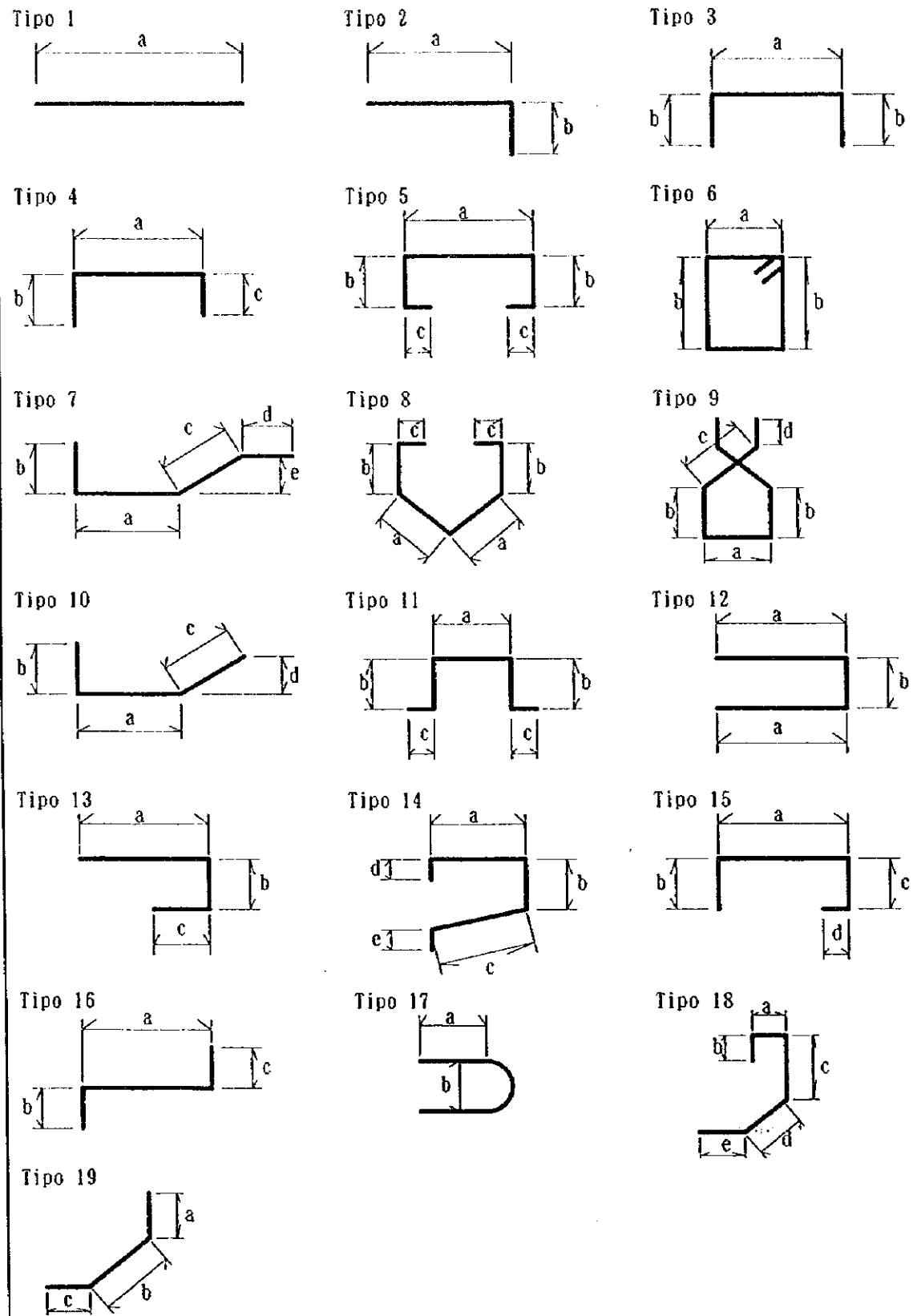

Marca	Dia. (mm)	Unit W. (kg/m)	Tipo	Dimensiones (mm)					Largos (mm)	Peso/Par. (kg)	Cant. Requ.	Peso Total (kg)	Obs.
				a	b	c	d	e					
1	25	3.853	3	6500	1500				9500	36.60	93	3,404.13	
2	25	3.853	3	6500	875				8250	31.79	47	1,494.00	
3	25	3.853	3	11400	1500				14400	55.48	27	1,498.05	
4	25	3.853	3	11400	875				13150	50.67	27	1,368.01	
5	22	2.984	3	11400	440				12280	36.64	8	293.15	
6	22	2.984	3	6500	440				7380	22.02	8	176.18	
7	25	3.853	2	4650	375				5025	19.36	96	1,858.69	
8	25	3.853	2	7210	375				7585	29.23	96	2,805.60	
9	22	2.984	1	10000					10000	29.84	40	1,193.60	
10	22	2.984	17	770	920				2986	8.91	40	356.41	
11	22	2.984	1	10986					10986	32.78	4	131.13	
12	25	3.853	18	420	760	732	551	500	2963	11.42	16	182.66	
13	22	2.984	1	12020					12020	35.87	4	143.47	
14	22	2.984	3	12020	440				12900	38.49	4	153.97	
15	22	2.984	3	1720	440				2600	7.76	4	31.03	
16	16	1.578	5	1720	620	136			3232	5.10	41	209.10	
17	16	1.578	6	1720	620				4920	7.76	4	31.06	
17	16	1.578	6	1720	484				4648	7.33	4	29.34	Var

Cubicaciones

Fecha : _____ Número de Puente : _____
 Nombre del Puente : DAVID GARCIA P2,P3
 De la Ruta, Camino : _____ Rol Ruta : _____
 En el Cauce : _____
 Región : V : VALPARAISO Provincia : _____
 Longitud del Puente : L = 104.05 m
 Número de Pistas : 2
 Ancho : 1.50+10.00+1.50 = 13.00 m
 Pendiente : 1.0% (Pasillos) 1.5% (Calzada)
 Tipo de Estructura : Cepa
 Altura de Cepa : H = 8.50 m
 Longitud de Viga : Lv = 25.95 m
 Luz : Lc = 25.25 m
 Número de Vigas : nv = 5.00
 Separación entre Vigas : S = 2.60 m
 Ancho Mesa Mínima : Wm = 10.90 m

Materia	Grado	Unidad	Cantidad	Observación
Cabezal				
Hormigón	H-25	m ³	15.59	
Moldaje		m ²	31.60	
Acero	A63-42H	kg	727.54	
Columna				
Hormigón	H-25	m ³	64.71	
Moldaje		m ²	138.85	
Acero	A63-42H	kg	8090.30	
Fundación				
Hormigón	H-25	m ³	144.90	
Moldaje		m ²	66.60	
Acero	A63-42H	kg	8859.15	
Total				
Hormigón	H-25	m ³	225.20	
Moldaje		m ²	237.05	
Acero	A63-42H	kg	17676.98	

Cubicaciones

Fecha : _____ Número de Puente : _____

Nombre del Puente : DAVID GARCIA A2

De la Ruta, Camino : _____ Rol Ruta : _____

En el Cauce : _____

Región : V: VALPARAISO Provincia : _____

Longitud del Puente : L = 104.05 m

Número de Pistas : 2

Ancho : 1.50+10.00+1.50 = 13.00 m

Pendiente : 1.0% (Pasillos) 1.5% (Calzada)

Tipo de Estructura : **Estribo**

Altura de Estribo : H = 9.00 m

Longitud de Viga : Lv = 25.95 m

Luz : Lc = 25.25 m

Número de Vigas : n_v = 5.00

Separación entre Vigas : S = 2.60 m

Ancho Mesa Mínima : Wm = 10.90 m

Materia	Grado	Unidad	Cantidad	Observación
Espaldar				
Hormigón	H-25	m ³	12.61	
Moldaje		m ²	57.62	
Acero	A63-42H	kg	1,044.96	
Muro				
Hormigón	H-25	m ³	80.50	
Moldaje		m ²	138.42	
Acero	A63-42H	kg	4,499.28	
Fundación				
Hormigón	H-25	m ³	137.09	
Moldaje		m ²	69.12	
Acero	A63-42H	kg	6,630.82	
Muros				
Hormigón	H-25	m ³	24.09	
Moldaje		m ²	96.13	
Acero	A63-42H	kg	2,863.14	
Total				
Hormigón	H-25	m ³	254.29	
Moldaje		m ²	361.30	
Acero	A63-42H	kg	15,038.20	

Tipo de Barras para hormigón

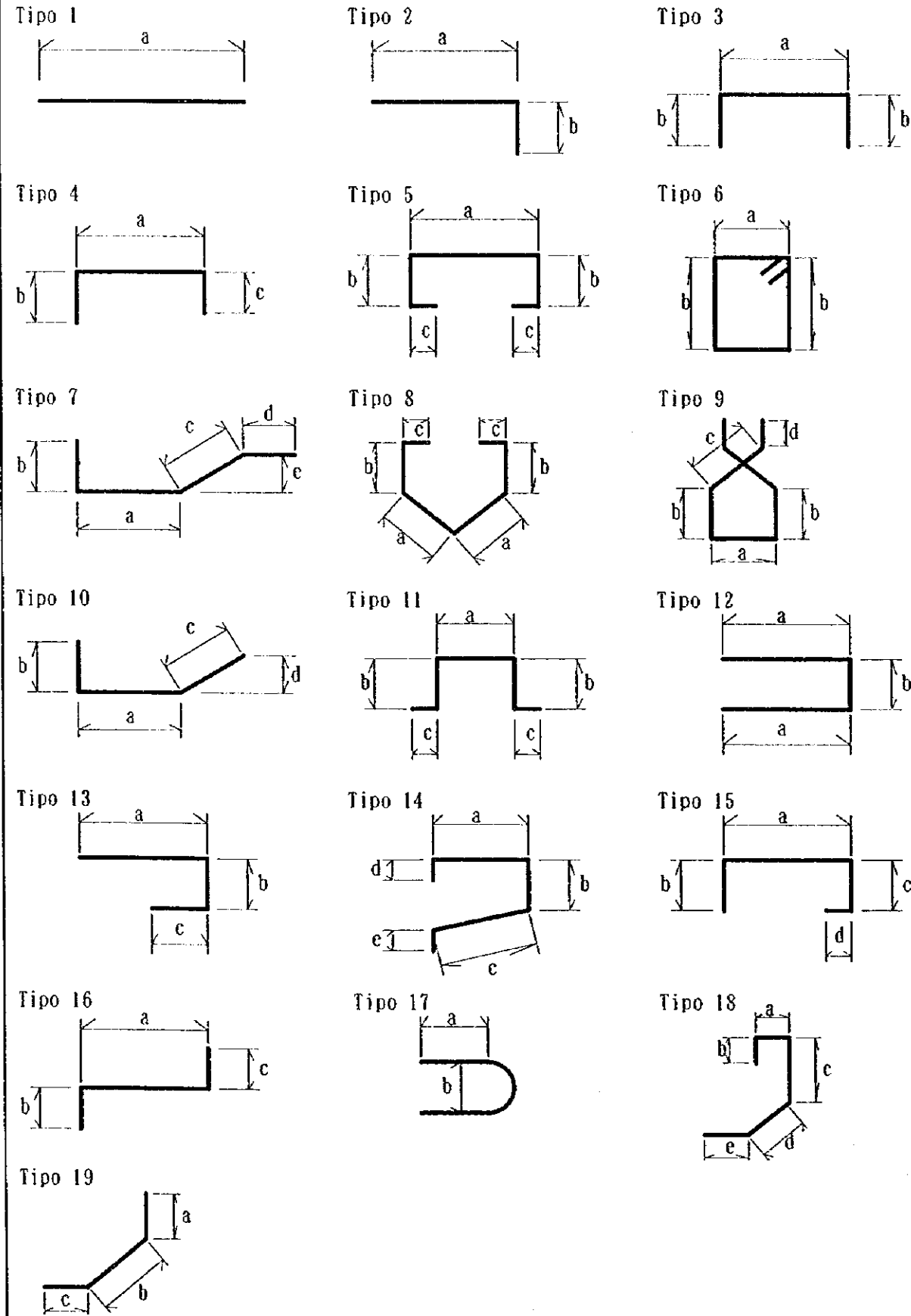

Marca	Dia. (mm)	Unit W. (kg/m)	Tipo	Dimensiones (mm)					Largos (mm)	Peso/Par (kg)	Cant. Requi.	Peso Total (kg)	Obs.
				a	b	c	d	e					
1	25	3.853	3	5500	1700				8900	34.29	55	1,886.04	
2	25	3.853	3	5500	875				7250	27.93	109	3,044.83	
3	18	1.998	3	13500	1700				16900	33.77	23	776.62	
4	18	1.998	3	13500	630				14760	29.49	23	678.28	
5	18	1.998	3	13500	360				14220	28.41	6	170.47	
6	18	1.998	3	5500	360				6220	12.43	6	74.57	
7	16	1.578	1	13120					13120	20.70	24	496.88	
8	16	1.578	1	13120					13120	20.70	24	496.88	
9	22	2.984	2	6760	330				7090	21.16	54	1,142.45	
10	22	2.984	2	4715	330				5045	15.05	53	797.88	
11	22	2.984	2	6760	330				7090	21.16	54	1,142.45	
12	16	1.578	3	13120	240				13600	21.46	6	128.76	
13	22	2.984	3	1120	330				1780	5.31	44	233.71	
14	18	1.998	3	970	520				2010	4.02	8	32.13	
15	18	1.998	3	720	520				1760	3.52	8	28.13	
16	12	0.888	1	13120					13120	11.65	9	104.86	
17	18	1.998	1	2740					2740	5.47	54	295.62	
18	12	0.888	1	13120					13120	11.65	6	69.90	
19	18	1.998	1	2740					2740	5.47	54	295.62	
20	12	0.888	1	13120					13120	11.65	3	34.95	
21	18	1.998	14	570	194	807	270	153	1993	3.98	48	191.14	
22	12	0.888	1	13120					13120	11.65	2	23.30	
23	12	0.888	3	470	390				1250	1.11	4	4.44	
24	12	0.888	3	320	102				524	0.47	54	25.13	
25	25	3.853	2	3820	375				4195	16.16	26	420.25	
26	25	3.853	2	3020	375				3395	13.08	4	52.32	
27	25	3.853	2	3620	375				3995	15.39	4	61.57	Var
28	25	3.853	2	3920	375				4295	16.55	8	132.39	
29	25	3.853	2	3010	375				3385	13.04	20	260.85	
30	25	3.853	2	3020	375				3395	13.08	10	130.81	
31	25	3.853	2	3600	375				3975	15.32	12	183.79	
32	25	3.853	2	9160	375				9535	36.74	22	808.24	
33	12	0.888	3	470	1444				3357	2.98	6	17.89	Var
34	12	0.888	10	944	180	1513	1070		2637	2.34	4	9.37	
35	12	0.888	2	3820	180				4000	3.55	26	92.35	
36	12	0.888	2	3020	180				3200	2.84	4	11.37	
37	12	0.888	2	3620	180				3800	3.37	4	13.50	Var
38	12	0.888	2	3920	180				4100	3.64	8	29.13	
39	12	0.888	2	9160	180				9340	8.29	22	182.47	
40	12	0.888	2	6760	180				6940	6.16	8	49.30	
41	25	3.853	2	2636	375				3011	11.60	26	301.64	
42	25	3.853	2	1504	375				1879	7.24	10	72.40	
43	12	0.888	2	470	102				572	0.51	28	14.22	
44	12	0.888	2	470	102				572	0.51	38	19.30	

II. GRANALLAS

1. Planos

(1) Planos de Vista General	2- 1
(2) Superestructura de Postensado	2- 2
(3) Infraestructura A1,A2 Estribo	2- 4
(4) Infraestructura P1 Cepa.....	2- 6

2. Informe del Cálculo (Tabla de Ingreso y Generalización)

(1) Superestructura de Postensado	2- 7
(2) Infraestructura A1,A2 Estribo	2- 9
(3) Infraestructura P1 Cepa.....	2- 12

3. Lista de Materiales

(1) Resumen de Cubicaciones	2- 14
(2) Superestructura de Postensado	2- 15
(3) Infraestructura A1 , A2 Estribo	2- 17
(4) Infraestructura P1 Cepa.....	2- 19

PLANTA
ESC. 1:200

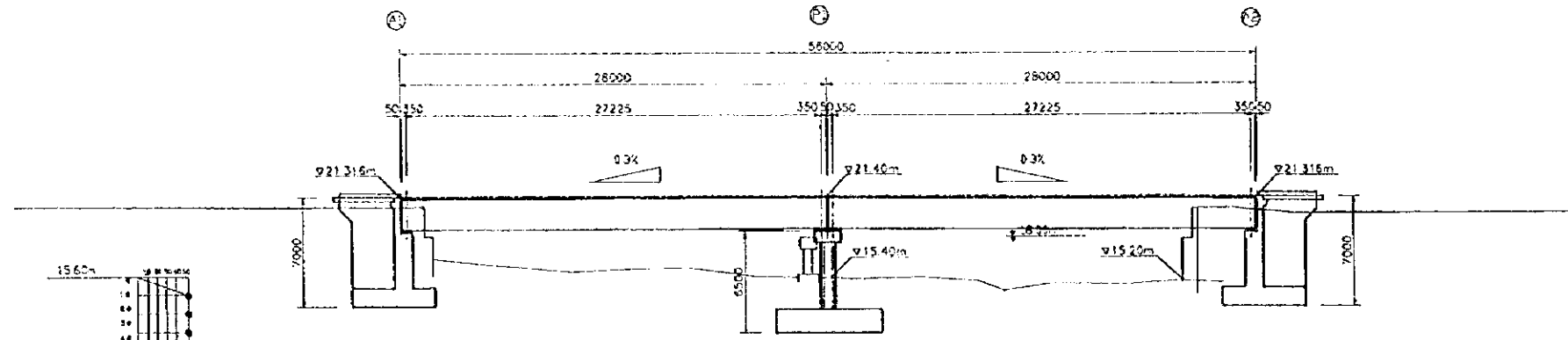

SECCION DE VIGA
ESC. 1:100

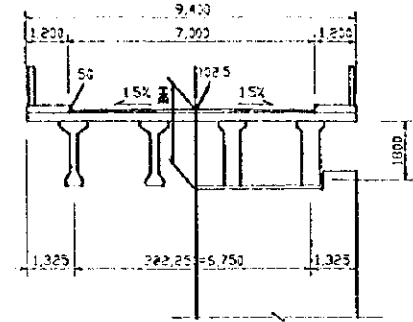

PLANTA
ESC. 1:200

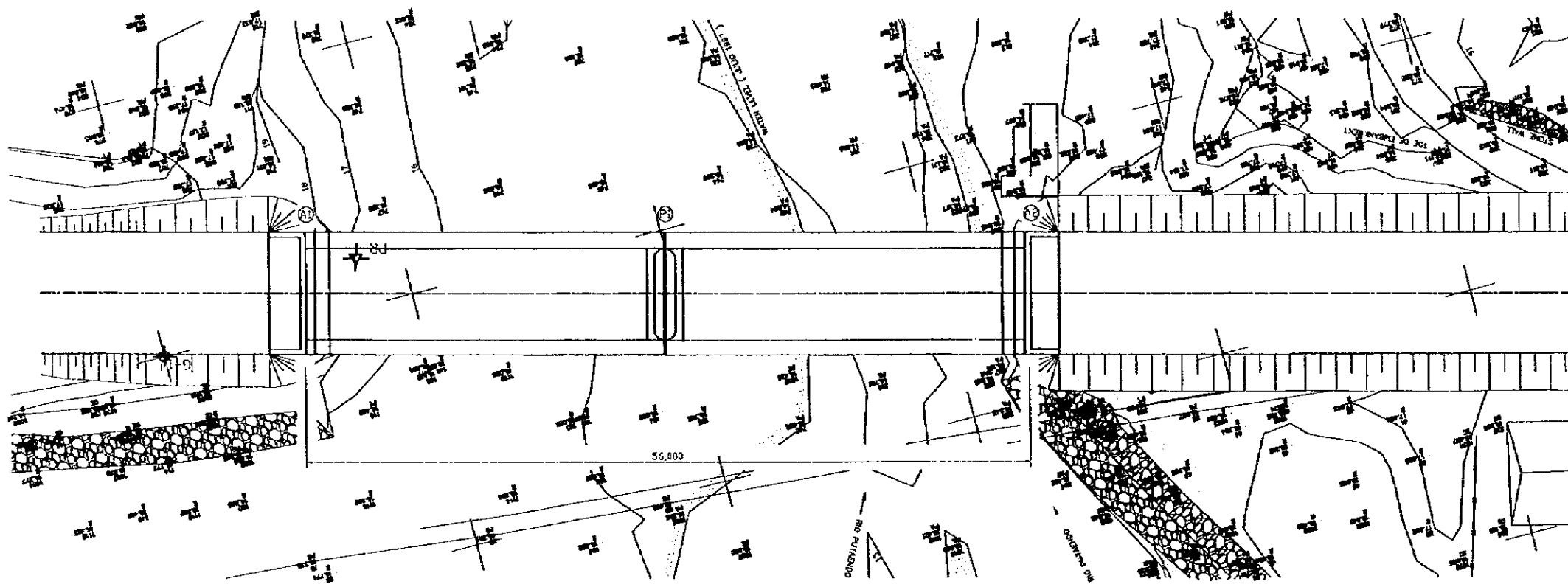

DETALLE DE BH

Pavimento	120
Losa	170
Viga	1800
Apoya Shoe	50
Pedestal	110
Total	2250

ESTRIBO
ESC. 1:100

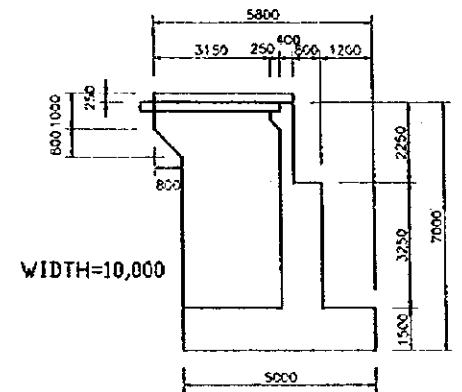

PILA
ESC. 1:100

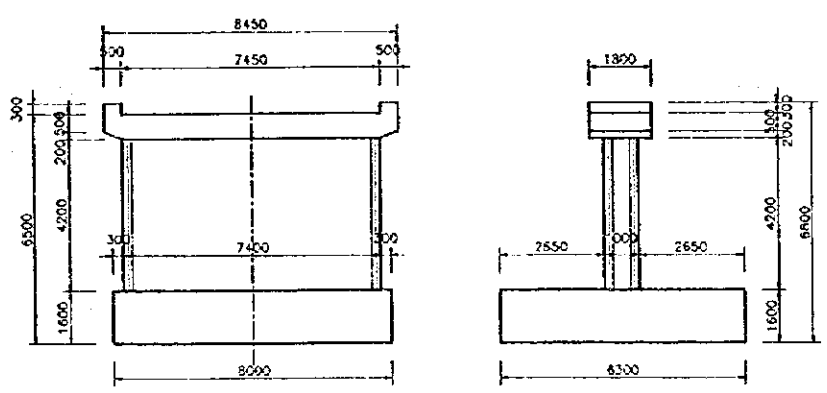

DIRECCION DE VIALIDAD DEPARTAMENTO DE PUENTES	
Puente: GRANALLAS	
Camino:	
Provincia:	Region: V
Proyecto:	Revis:
Va. Ing. Jefe Depto. Puentes	Director de Vialidad
Fecha:	Vista General

PLANTA DE LOSA
ESC. 1:50

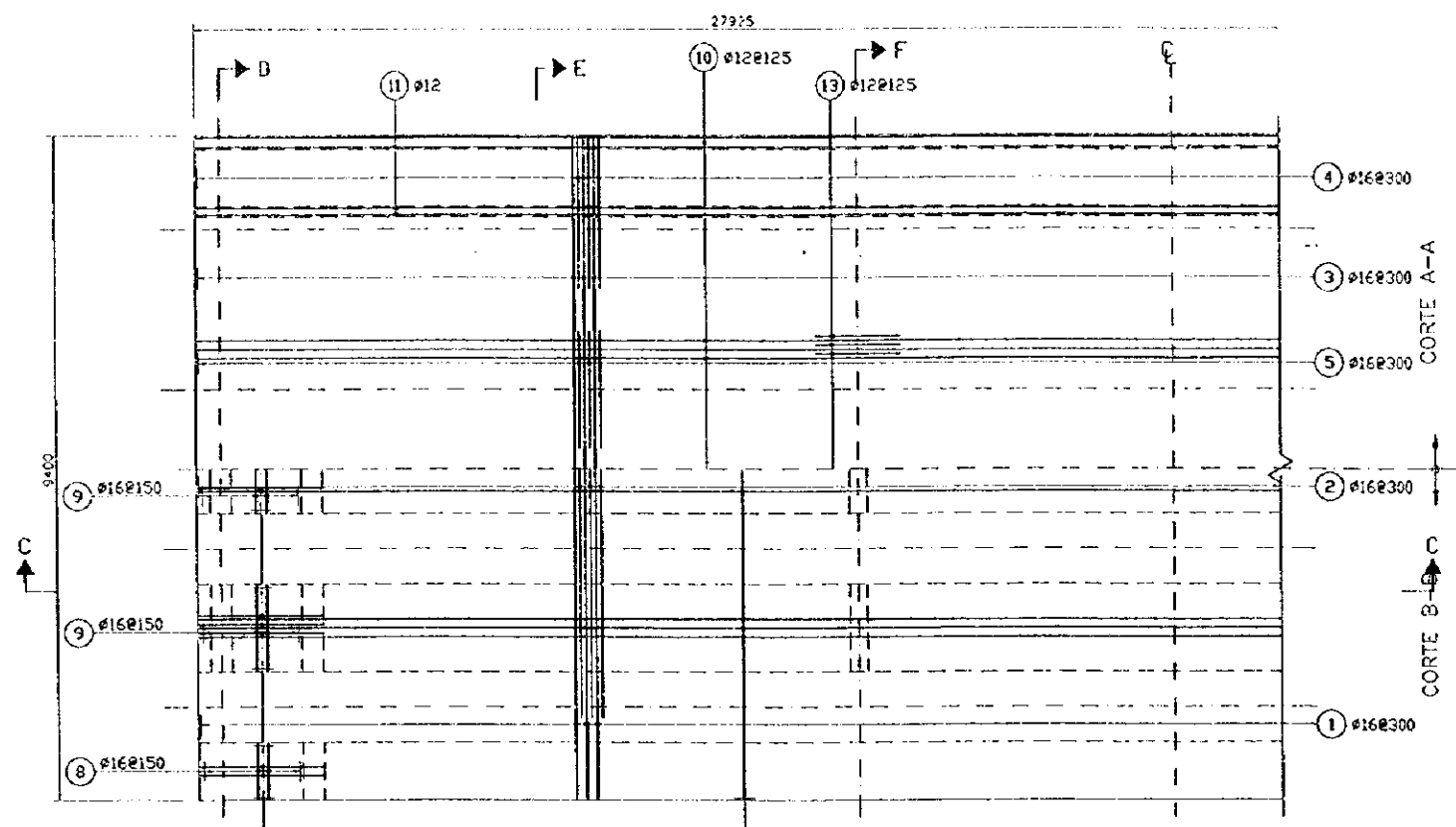

CORTE TRVERSAL
CORTE E-E
ESC. 1:50

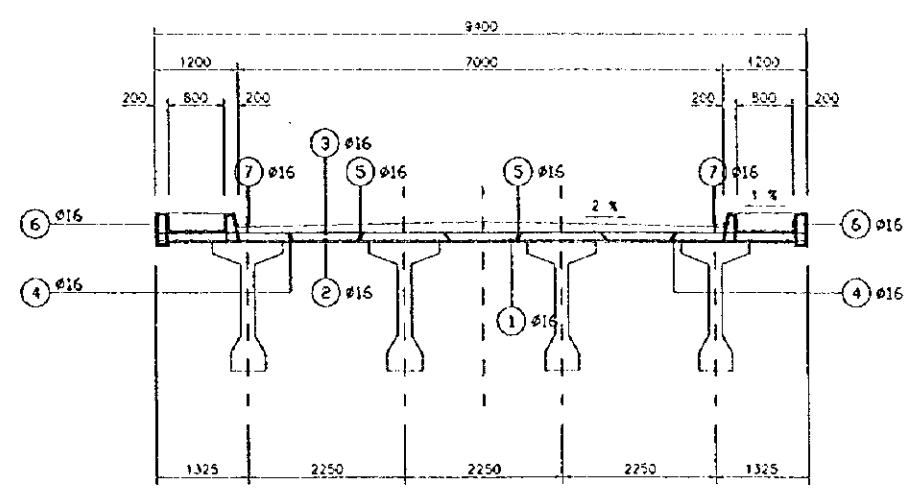

TRAVESAÑOS EXTREMOS
CORTE D-D ESC. 1:50 CORTE F-F

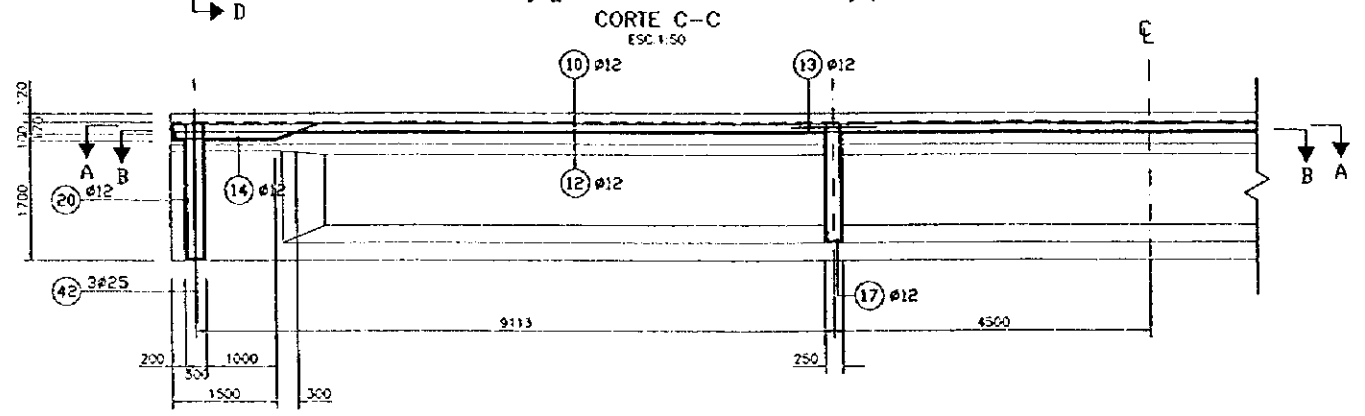
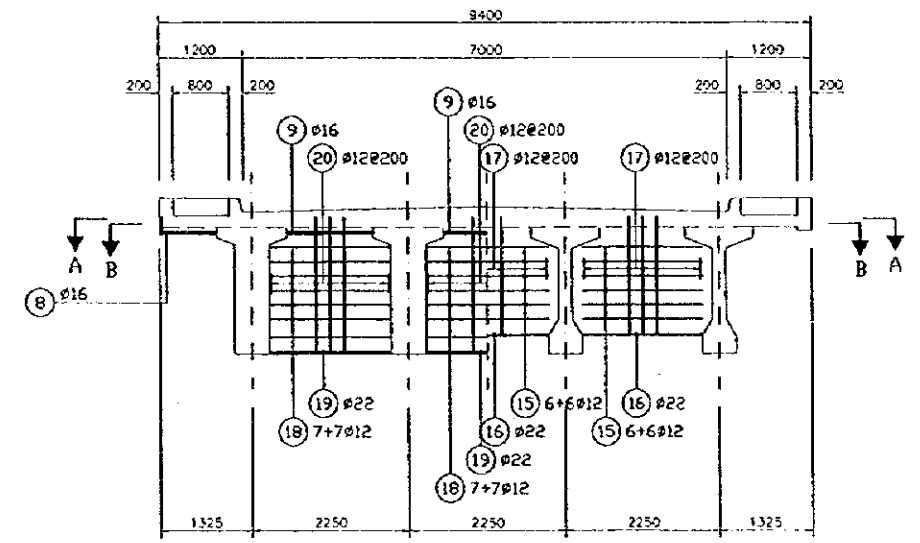

DETALLE BARRAS ANTISISMICAS
ESC. 1:5

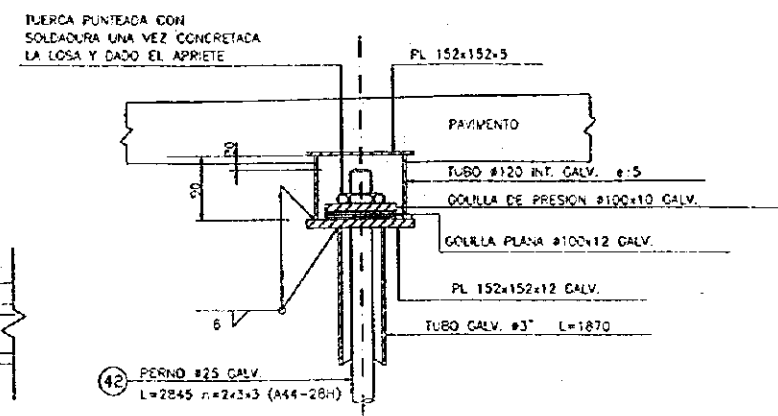

DETALLE DE PASILLO
ESC. 1:10

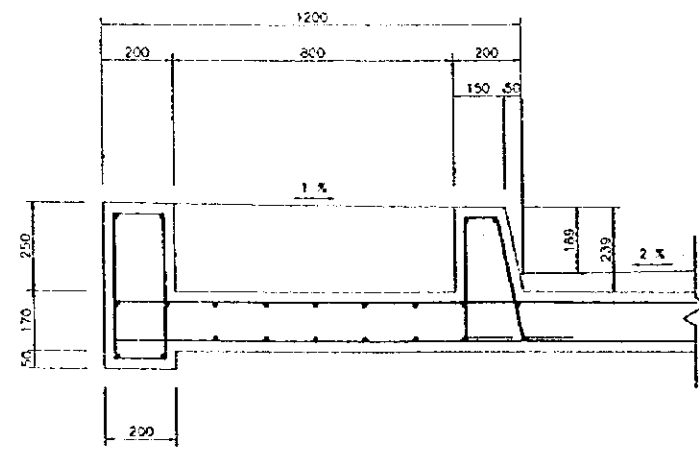

PLANTA DE DISPOSICION

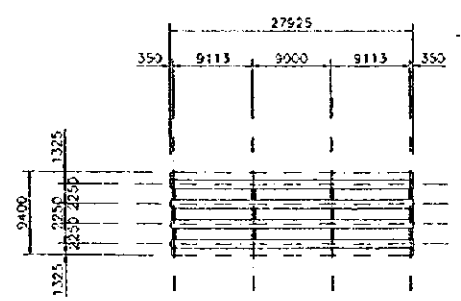

DIRECCION DE VIALIDAD DEPARTAMENTO DE PUENTES	
Puente: GRANALLAS	
Camino:	
Provincial:	Region: X
Projecto	Reviso
Vo. de Ing. Jefe Depto. Puentes	Director de Vialidad
Fecha:	

1/2 ELEVACION DE VIGA POSTENSADO
ESC. 1:50

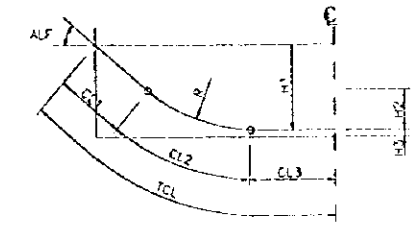
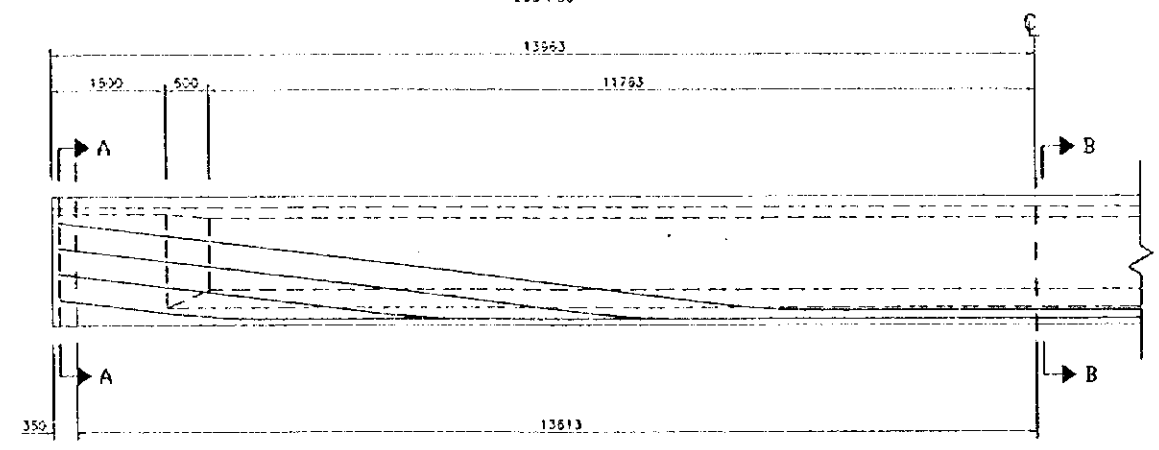

	ALF	R	H1	H2	H3	CL1	CL2	CL3	TCL
D1	7	10	1230	75	210	9481	1222	3253	13936
D2	7	10	990	75	90	7512	1222	5183	13922
D3	7	10	650	75	90	4558	1222	8120	13900
D4	7	10	270	75	90	1604	1222	11052	13877

1/2 ENFIERRADURA VIGA POSTENSADO
ESC. 1:50

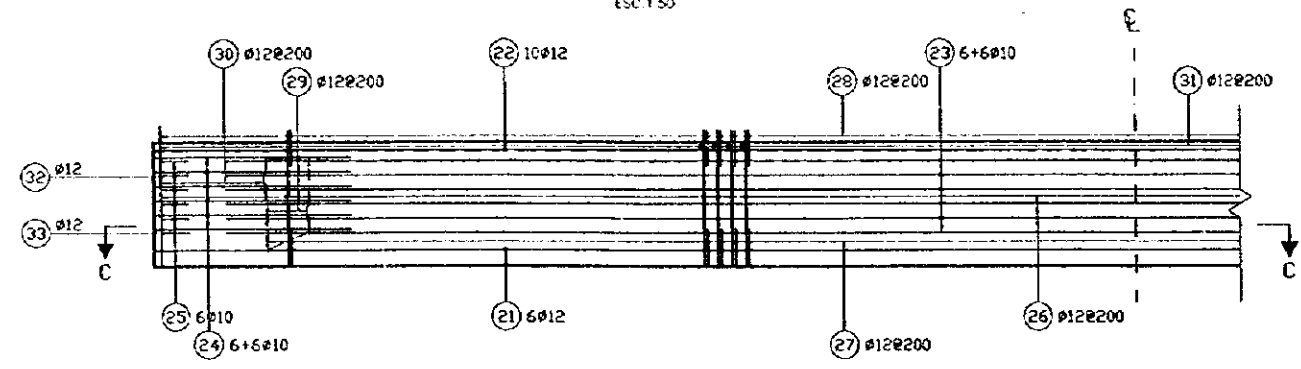

CORTE C-C
ESC. 1:50

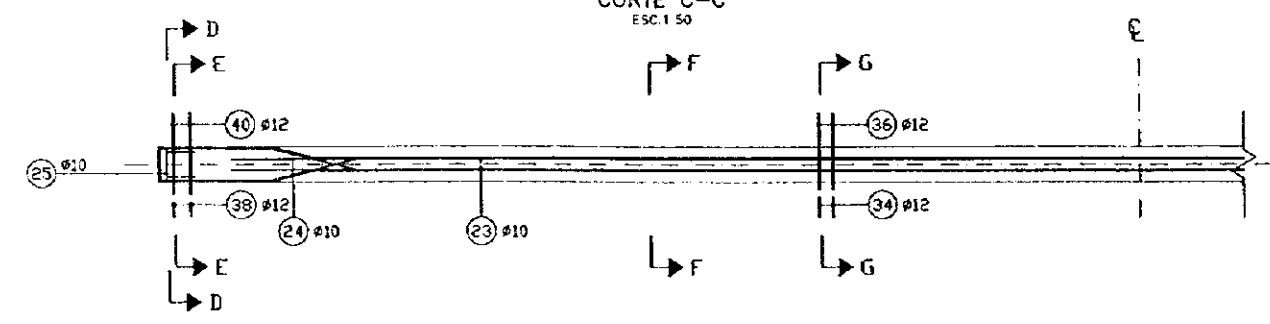

CORTE A-A
ESC. 1:20

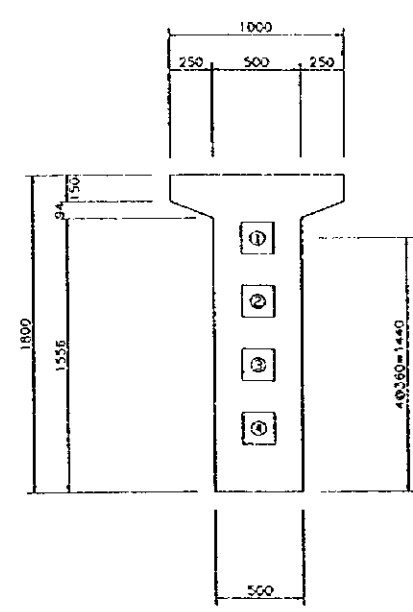

CORTE B-B
ESC. 1:20

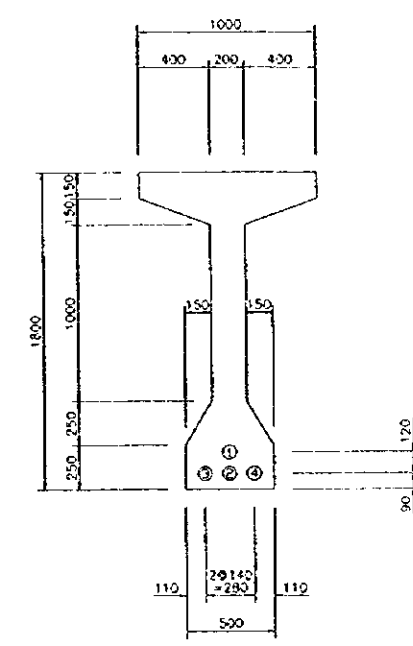

CORTE D-D
ESC. 1:25

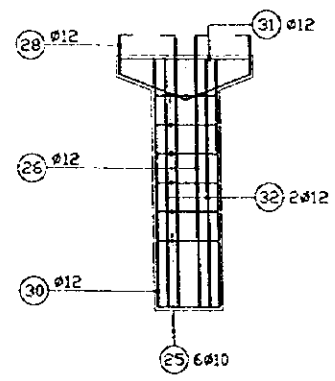

CORTE E-E
ESC. 1:25

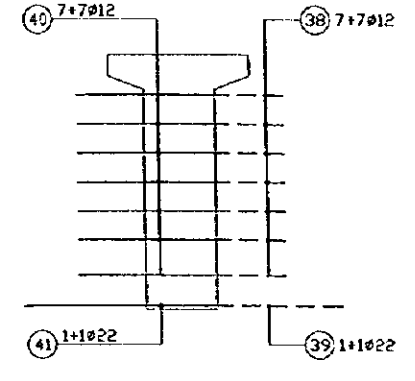

CORTE F-F
ESC. 1:25

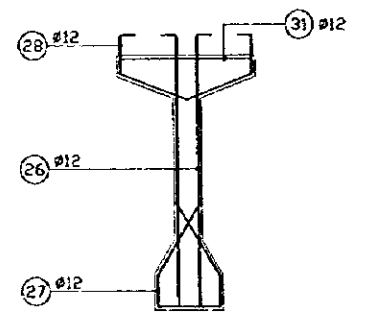

CORTE G-G
ESC. 1:25

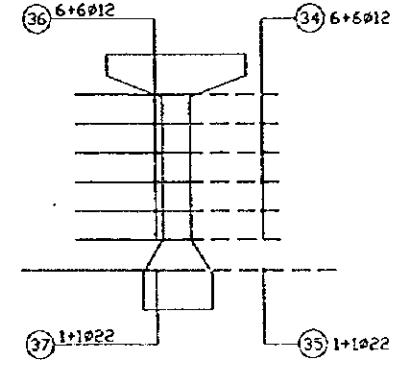

DIRECCION DE VIALIDAD DEPARTAMENTO DE PUENTES	
Puente: GRANALLAS	
Camino:	
Provincia:	Region: X
Proyecto	Revisa
Va. Sr. Ing. Jefe Depto. Puentes	Director de Vialidad
Dibujo	Fecha

1/2 ENF. FRONTAL ESC. 1:50 1/2 ENF. POSTERIOR

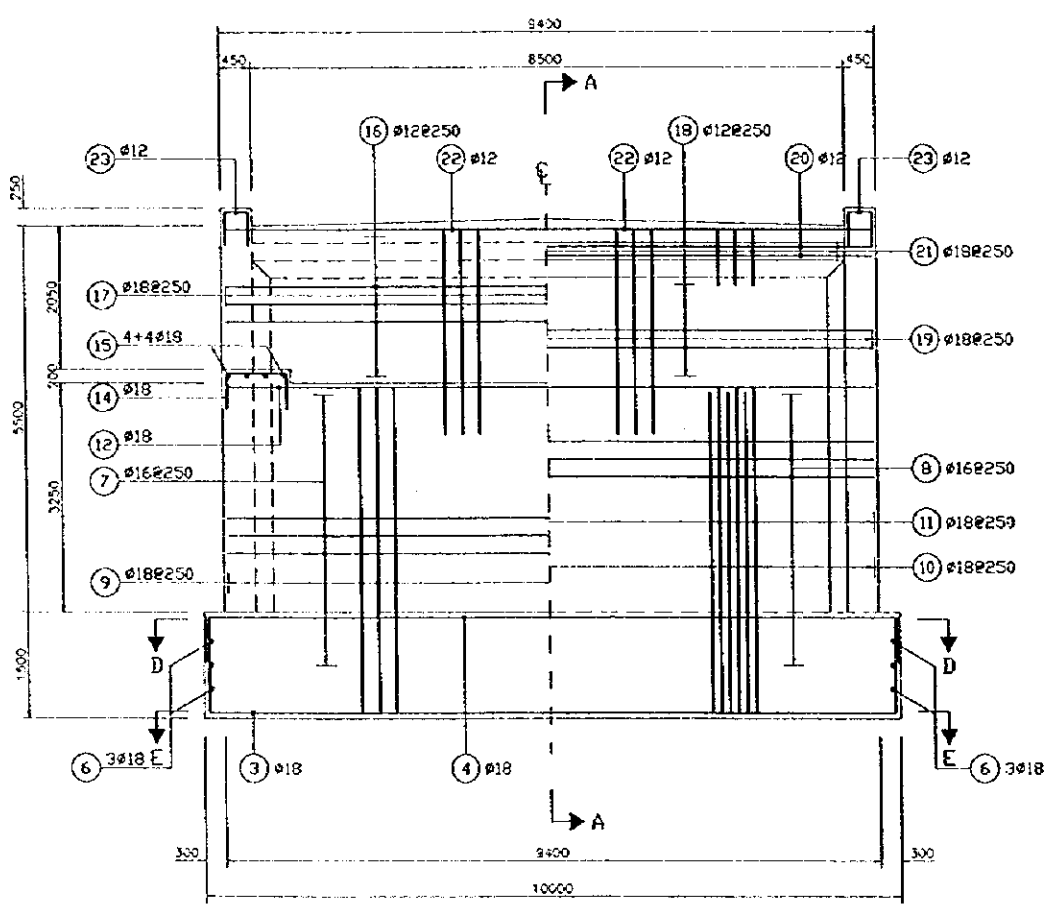

CORTE A-A ESC. 1:50

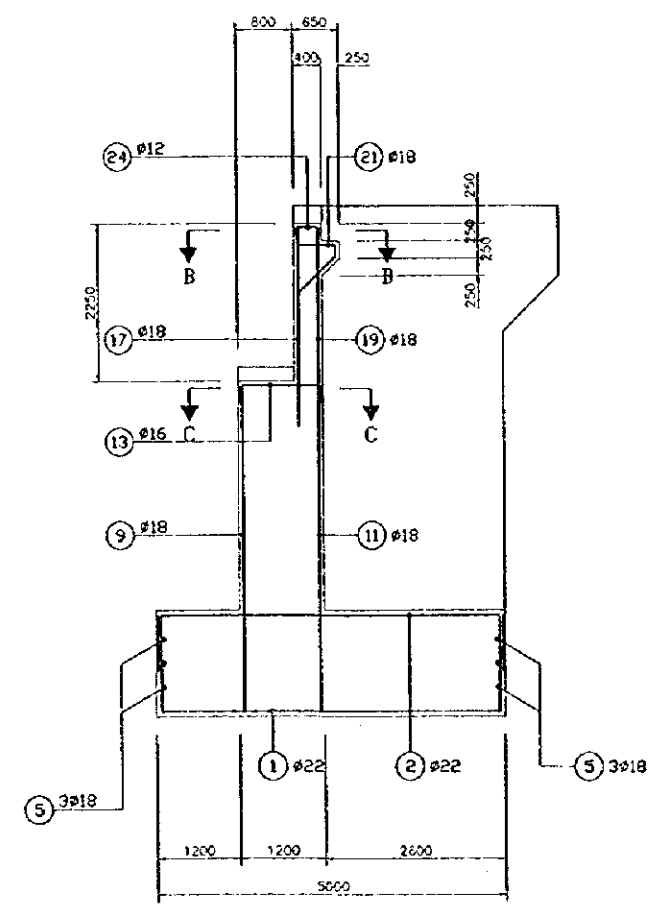

1/2 PLANTA ESC. 1:50 1/2 CORTE C-C

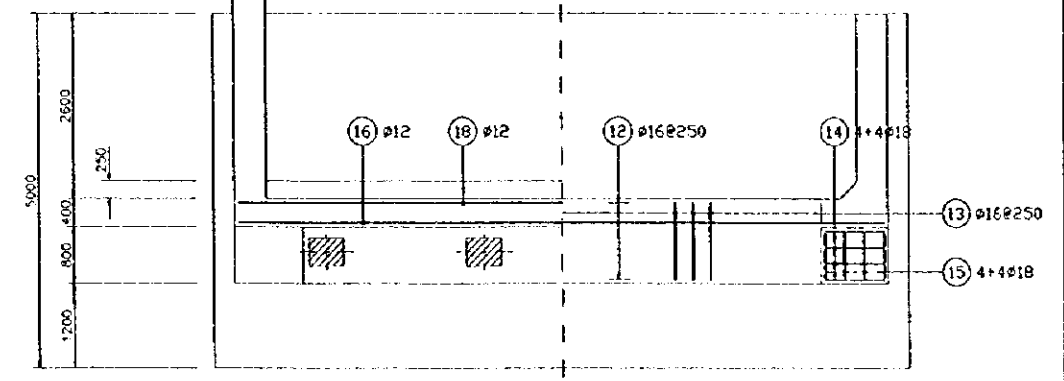

1/2 CORTE D-D ESC. 1:50 1/2 CORTE E-E

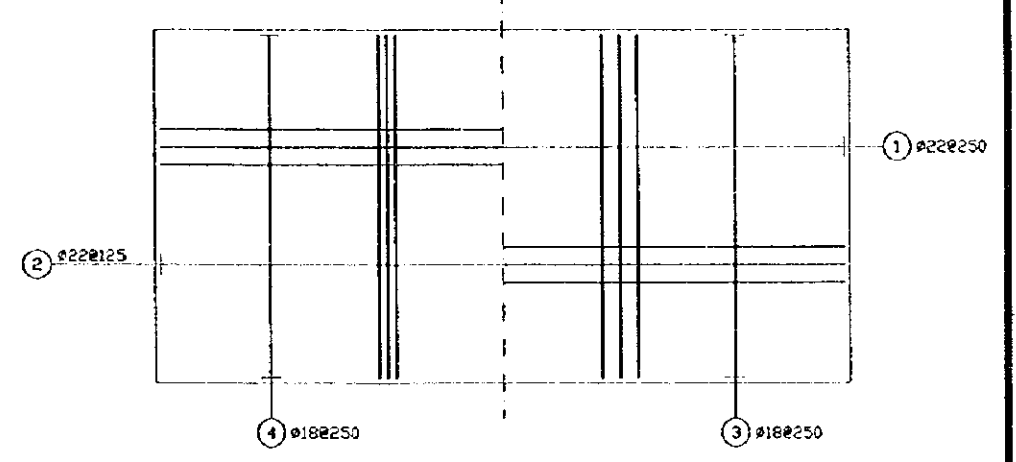

DIRECCION DE VIALIDAD DEPARTAMENTO DE PUENTES	
Puente: GRANALLAS ALA2	
Camino:	
Provincia:	Region: X
Proyecto	Reviso
Va. Sr. Ing. Jefe Depto. Puentes	Director de Vialidad
Escala:	
Fecha:	

1/2CORTE A-A

1/2CORTE B-B

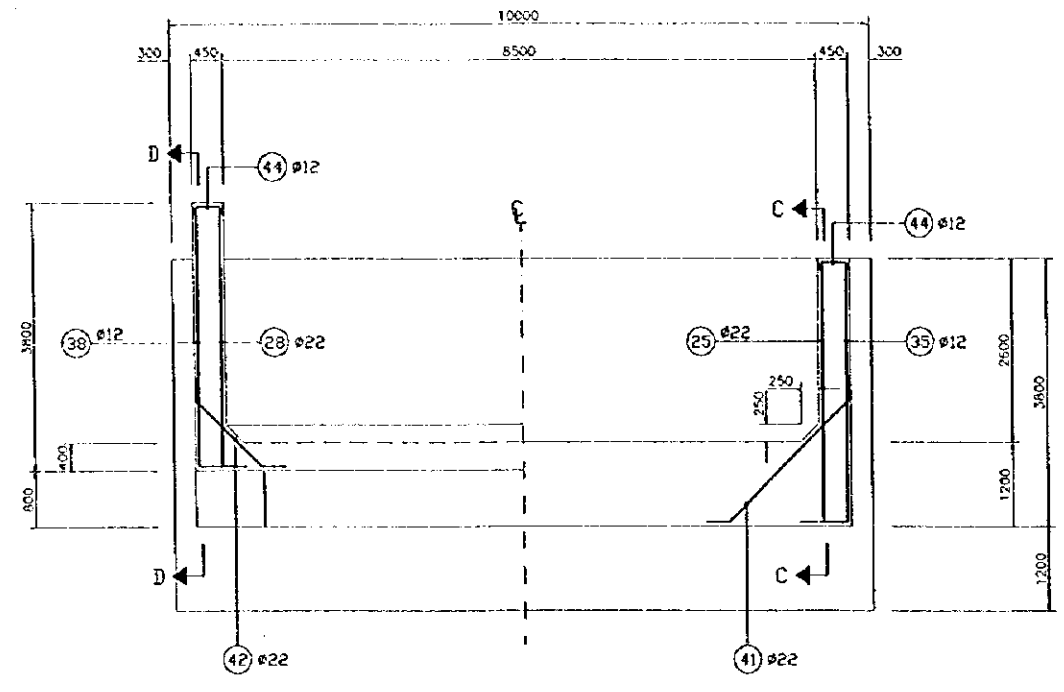

ENFIERRADURA ALA
CORTE C-C
ESC. 1:50

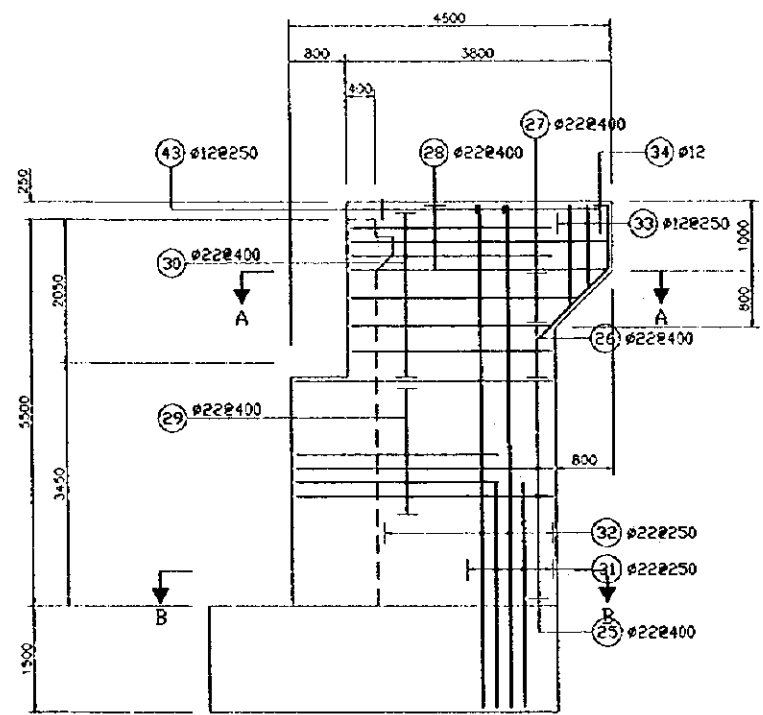

ENFIERRADURA ALA
CORTE D-D
ESC. 1:50

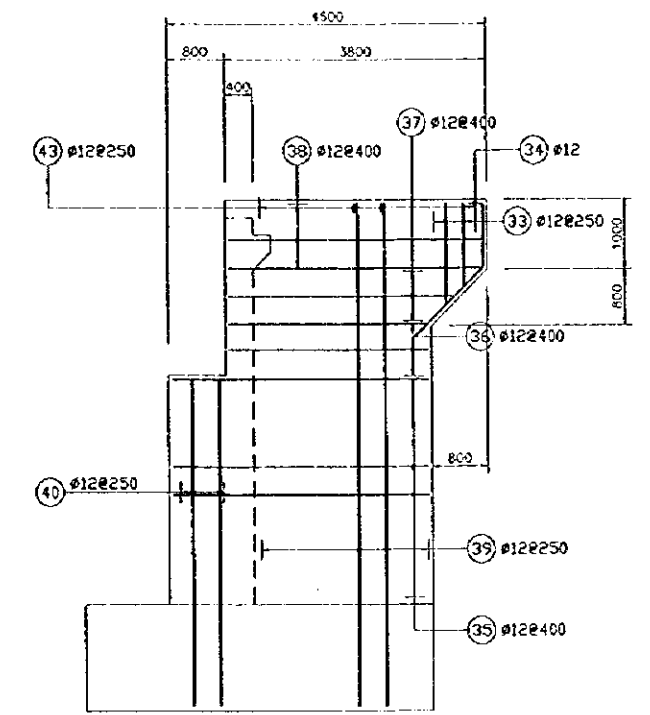

DIRECCION DE VIALIDAD DEPARTAMENTO DE PUENTES	
Puente: GRANALLAS A1,A2	
Camino:	
Provincia:	Region: X
_____ Proyecto	_____ Reviso
_____ Vº Bº Ing. Jefe Depto. Puentes	_____ Director de Vialidad
Dibujo: _____ Fecha: _____	

1/2 PLANTA CEPA ESC. 1:50 1/2 CORTE A-A

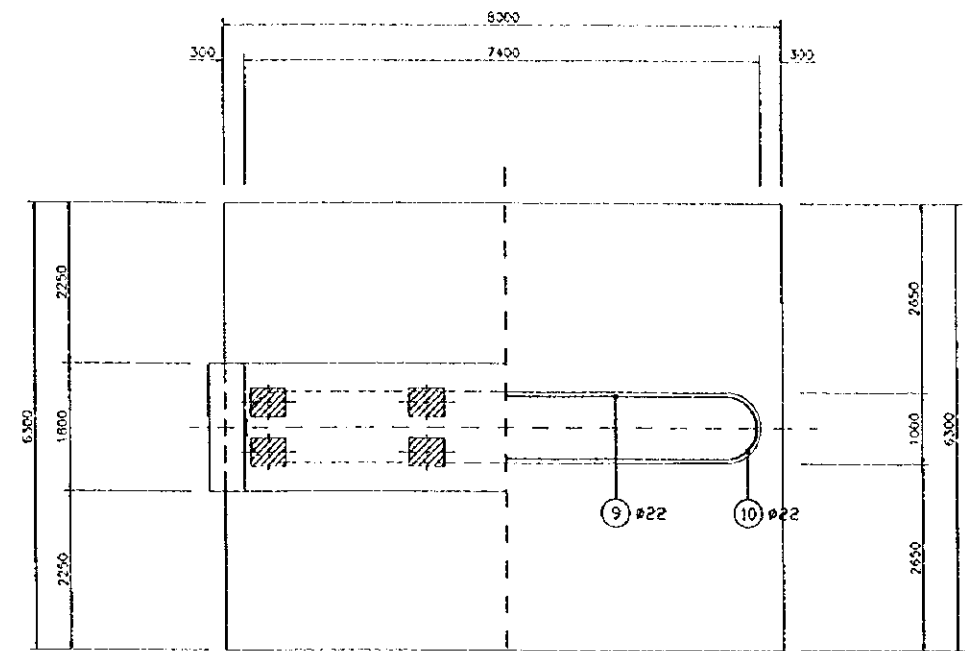

1/2 CORTE B-B ESC. 1:50 1/2 CORTE C-C

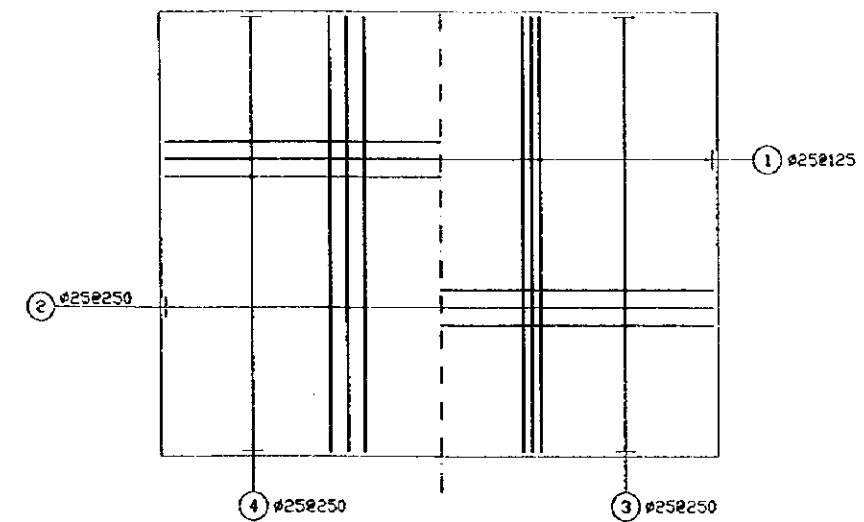

EREVACION CEPA ESC. 1:50

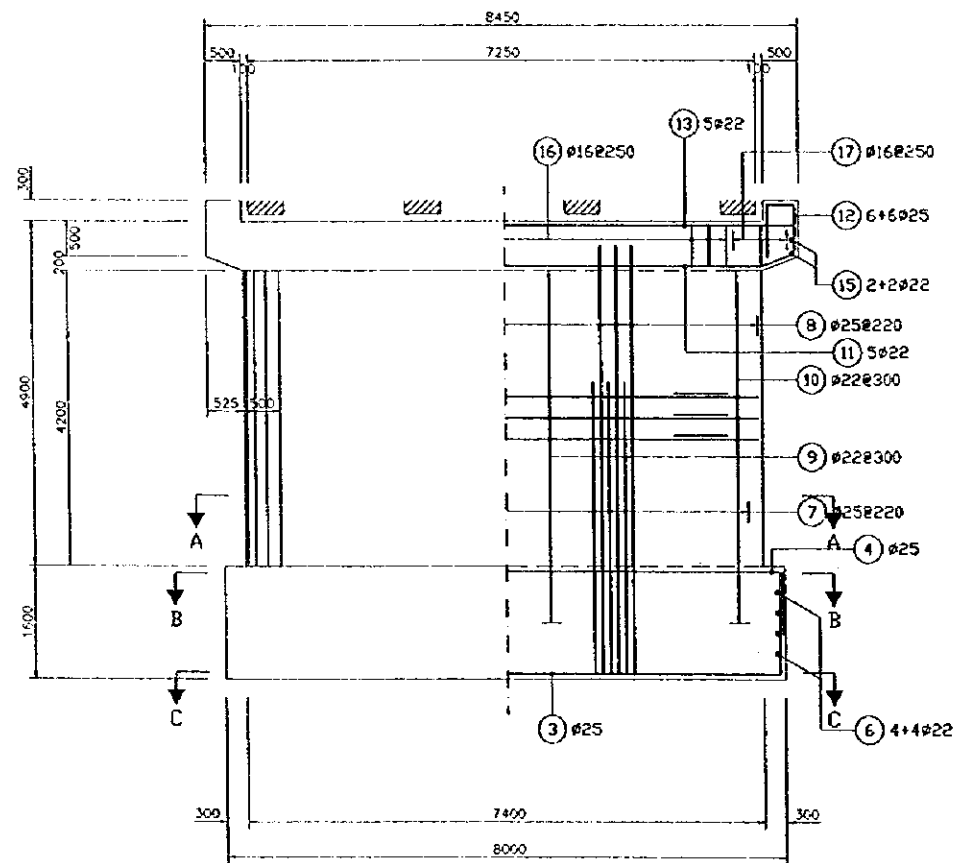

EREVACION LATERAL ESC. 1:50

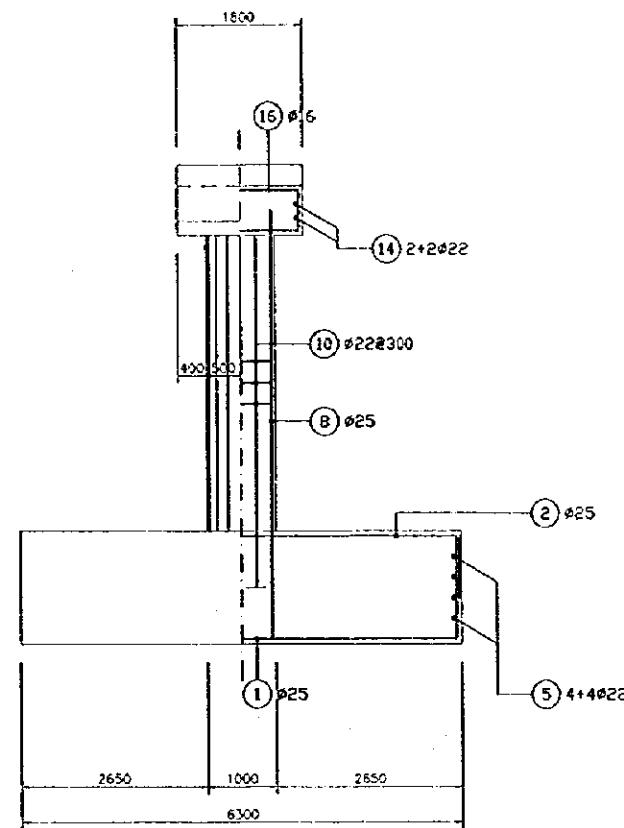

DIRECCION DE VIALIDAD
DEPARTAMENTO DE PUENTES

Puente: GRANALLAS PI
Camino:
Provincia: Region: X

Projecto: Revisa:
Vista Ing. Jefe Depto. Puentes Director de Vialidad

Dibujo: Fecha:

Resultado del diseño

Tipo de Estructura : **Viga de Postensado**

Fecha :

(1) Datos Generales

Nombre del Puente : **GRANALLAS**

Número de Puente :

De la Ruta, Camino :

Rol Ruta :

En el Cauce :

Región : **X : LOS LAGOS**

Provincia :

Longitud del Puente : $L = 56.000 \text{ m}$, Luz(Longitud de cálculo) : $L_c = 27.225 \text{ m}$

Número de Pistas : **2**

Ancho : $1.200 + 7.000 + 1.200 = 9.400 \text{ m}$

(Pasillos) (Calzada) (Pasillos)

Pendiente : **1.0 2.0 1.0 %**

Espesor mínimo del Pavimento : **50 mm** , Espesor máximo del Pavimento : **120 mm**

Ancho de Baranda : $B_b = 200 \text{ mm}$, $h_b = 0.250 \text{ m}$

(2) Cargas

Baranda : $W_B = 0.050 \text{ t/m}$, $W_L = 0.020 \text{ t/m}$, $h = 1.100 \text{ m}$

Cargas de Pavimento : **2.30 t/m³**

Hormigón : **2.30 t/m³ (en masa)** , **2.50 t/m³ (armado y/o postensado)**

Acero : **7.85 t/m³**

Peatones : $W_p = 0.415 \text{ t/m}^2$ (Losa)
 0.293 t/m^2 (Viga)

Cargas de Tránsito : **HS20-44**

Cargas de Viento : $W_v = 0.244 \text{ t/m}^2$

Coefficientes sísmicos : $K_h = 0.15$, $K_v = 0.00$

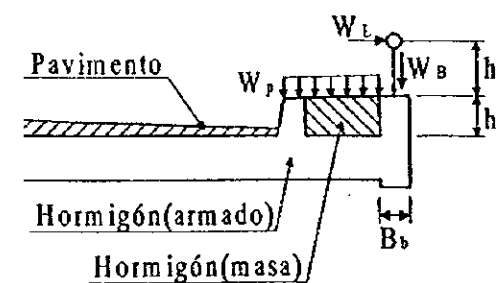

(3) Material

Hormigón :

Losa y Travesaño grado : **H-30** $f_{cL} = 250 \text{ kg/cm}^2$, $f_{rC} = 100 \text{ kg/cm}^2$

$$E_{RC} = w_c^{1.5} \times 33 \sqrt{f_{RC}} = 57000 \sqrt{f_{RC}} \text{ psi} = 15800 \sqrt{f_{RC}} \text{ kg/cm}^2 = 2.50 \times 10^5 \text{ kg/cm}^2$$

$$w_c = 145 \text{ pcf} = 2.32 \text{ kg/m}^3 \quad (\text{AASHTO 8.7.1})$$

Viga grado : **H-40** $f_{cV} = 350 \text{ kg/cm}^2$, $E_{PC} = 3.01 \times 10^5 \text{ kg/cm}^2$

$$f_{cV}' = 280 \text{ kg/cm}^2$$

$$E_s = 29,000,000 \text{ psi} = 2.1 \times 10^6 \text{ kg/cm}^2$$

Acero para Armadura de Losa y Viga : **A63-42H** $f_y = 4200 \text{ kg/cm}^2$, $f_{sa} = 1690 \text{ kg/cm}^2$

Acero Travesaño y barras antisísmicas : **A44-28H** $f_y = 2800 \text{ kg/cm}^2$, $f_{sa} = 1400 \text{ kg/cm}^2$

Acero (cable) : Grado **270 K** , **ASTM416-80** Cable : **7-12.7** $As^* = 6.910 \text{ cm}^2$

Tensión de ruptura : $f_{ps} = 18980 \text{ kg/cm}^2$, $E_s = 1.97 \times 10^6 \text{ kg/cm}^2$

Tensión de fluencia : $f_{py} = 16100 \text{ kg/cm}^2$

(4) Geometría :

Determinación de número de barras y espaciamiento : $\phi 16 @ 150$ $As = 13.407 \text{ cm}^2$

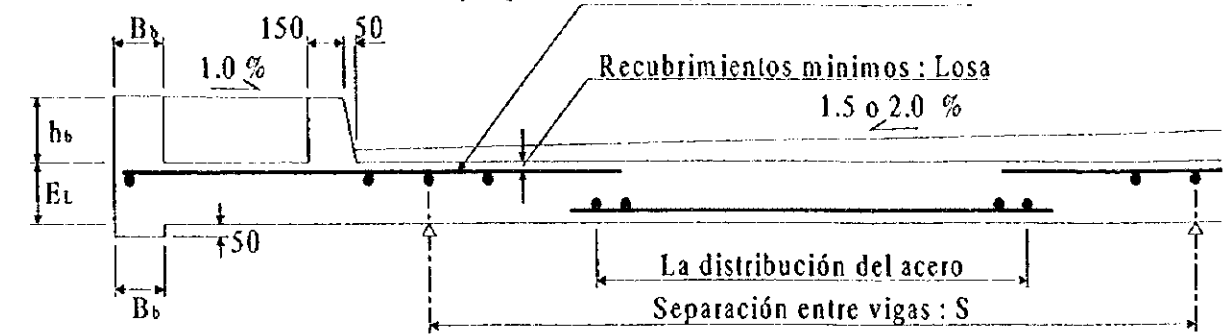

Espesor de losa : $E_L = 170 \text{ mm}$, Recubrimientos mínimos : Losa **3.0 cm**

La distribución del acero en el fondo de losa : $\phi 12 @ 125$ $As = 9.048 \text{ cm}^2$

Número de Vigas : $n_v = 4$, Separación entre vigas : $S = 2.250 \text{ m}$, $3 @ 2.250 = 6.750 \text{ m}$

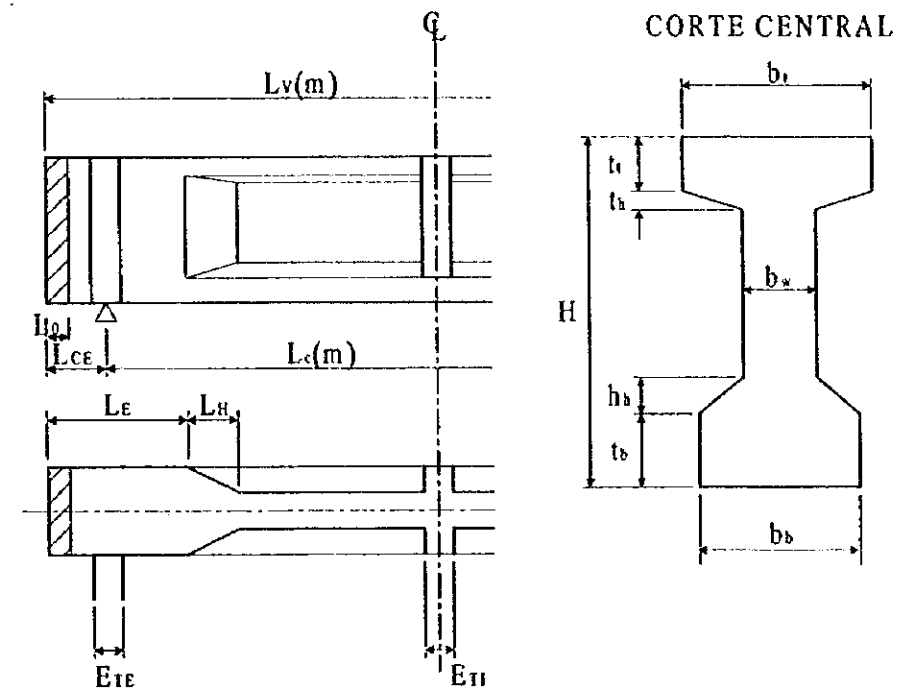

Longitud de Viga : $L_v = 27.925 \text{ m}$, $L_{ce} = 0.350 \text{ m}$, $L_o = 100 \text{ mm}$

$L_e = 1600 \text{ mm}$, $L_h = 600 \text{ mm}$, $E_{te} = 300 \text{ mm}$, $E_{ti} = 250 \text{ mm}$

Altura de Viga : $H = 1.800 \text{ m}$

$b_t = 1000 \text{ mm}$, $t_t = 150 \text{ mm}$, $t_b = 150 \text{ mm}$, $b_w = 200 \text{ mm}$

$h_b = 250 \text{ mm}$, $t_b = 250 \text{ mm}$, $b_b = 500 \text{ mm}$

Coefficiente de rozamiento parásito : $K = 0.0045$

Coefficiente de rozamiento en curva : $\mu = 0.25$

Número de Travesaños (Intermedio) : **2**

Separación entre Travesaño : **9.000 m**

Ancho Mesa Mínimo : $W_m = 7.250 \text{ m}$

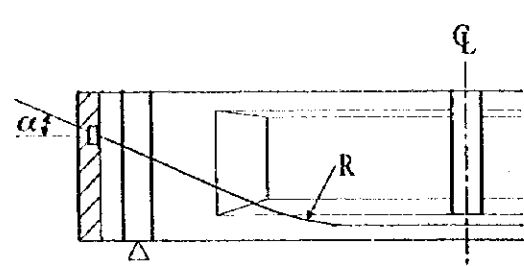

No.	$\alpha(\text{deg})$	R(m)
1	7.0	10.00
2	7.0	10.00
3	7.0	10.00
4	7.0	10.00
5	0.0	0.00
6	0.0	0.00
7	0.0	0.00

CORTE FINAL CORTE CENTRAL

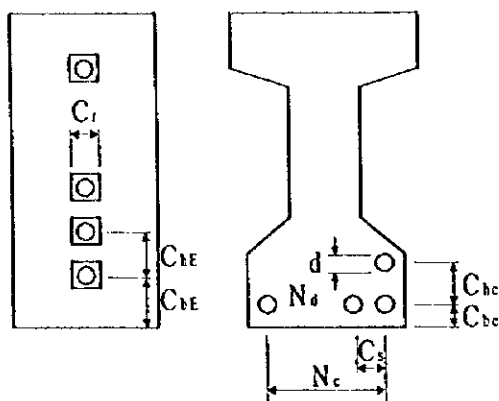

Número de ductos a descontar :

$N_d = 4, \quad d = 80 \text{ mm}$
 $N_c = 3, \quad C_s = 140 \text{ mm}$
 $C_{bc} = 120 \text{ mm}, \quad C_{bc} = 90 \text{ mm}$
 $C_r = 180 \text{ mm}$
 $C_{be} = 360 \text{ mm}, \quad C_{be} = 360 \text{ mm}$
 $C_{dc} = 12.0 \text{ cm}, \quad C_{DE} = 90.0 \text{ cm}$

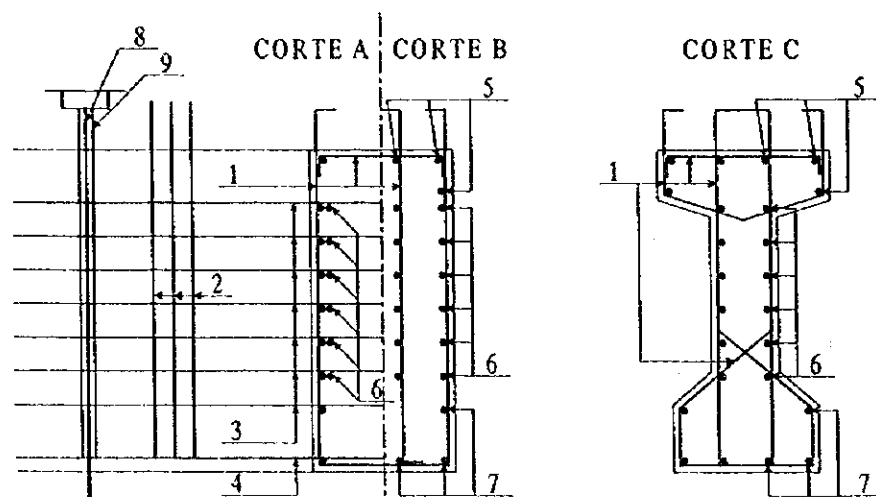
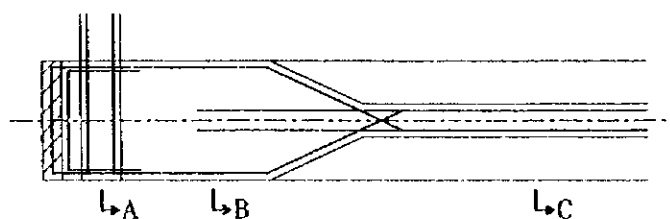

Recubrimientos mínimos : Viga 2.5 cm

1 : $\phi 12 @ 200, \quad 2 : \phi 12 @ 200, \quad 3 : \phi 12 \text{ n } 7, \quad 4 : \phi 22$
 5 : $\phi 12, \quad 6 : \phi 10 \text{ n } 6, \quad 7 : \phi 12$
 8 : $\phi 25 \text{ n } 3, \quad 9 : \phi 3''$

Cuantificación del Postensado

(5) Diseño de Losa

$E_M \text{ (cm)}$	$E_L \text{ (cm)}$	$d_{req} \text{ (cm)}$	$d \text{ (cm)}$	$A_{sreq} \text{ (cm}^2\text{)}$	$A_s \text{ (cm}^2\text{)}$	
16.5	≤ 17.0	OK	13.5 ≤ 14.0	OK	$12.802 \leq \phi 16 @ 150 = 13.407$	OK
$\phi M_n \text{ (tm/m)}$	$M_u \text{ (tm/m)}$	Distribución : $A_s \text{ (cm}^2\text{)}$				
6.424	≥ 5.253	OK	$67 (\%) 8.577 \leq \phi 12 @ 125 = 9.048$			OK

(6) Diseño de Viga

$(x = l/2 = 13.613 \text{ m})$

	Exterior		Interior	
	Transferencial	Servicio	Transferencial	Servicio
Fatiga (kg/cm^2)	Total $f_s \text{ (kg/cm}^2\text{)}$	Total $f_s \text{ (kg/cm}^2\text{)}$	Total $f_s \text{ (kg/cm}^2\text{)}$	Total $f_s \text{ (kg/cm}^2\text{)}$
Viga Superior : f_{vs}	$5 \leq 168$ OK	$68 \leq 140$ OK	$5 \leq 168$ OK	$69 \leq 140$ OK
Viga Inferior : f_{vi}	$115 \leq 168$ OK	$-7 \geq -15$ OK	$115 \leq 168$ OK	$-9 \geq -15$ OK

$(x = 10.379 \text{ m})$ Interior

	Transferencial	Servicio
Fatiga (kg/cm^2)	Total $f_s \text{ (kg/cm}^2\text{)}$	Total $f_s \text{ (kg/cm}^2\text{)}$
Viga Superior : f_{vs}	$2 \leq 168$ OK	$63 \leq 140$ OK
Viga Inferior : f_{vi}	$121 \leq 168$ OK	$1 \leq 140$ OK

$A_p \text{ (cm}^2\text{)}$	$A_s \text{ (cm}^2\text{)}$	$\phi M_n \text{ (tm)}$	$M_u \text{ (tm)}$	$\phi M_n \text{ (tm)}$	$1.2 M_u \text{ (tm)}$
$4 \times 6.910 = 27.640$	$6 \times \phi 12 = 6.786$	$931.469 \geq 777.375$	OK	$931.469 \geq 681.853$	OK

(7) Verificación de Corte

$h/2 = 0.900 \text{ m}$	$A_v = 6 \times \phi 12 = 6.786 \text{ cm}^2$	$s = 20.0 \text{ cm}$	$d_p = 90.0 \text{ cm}$
$V_v = 107.483 \text{ t}$	$\leq \phi(V_c + V_s) = 0.9 \times (98.062 + 128.255) = 203.686 \text{ t}$ OK		
Cálculo de Conectores	$A_v = 4 \times \phi 12 = 4.524 \text{ cm}^2$	$V_v = 107.483 \leq \phi V_{nb} = 430.457$	OK

(8) Deflexión de Transferencia

$\delta_D \text{ (cm)}$	$\delta_L \text{ (cm)}$	$L_c/800$
2.9	1.0	≤ 3.4

(9) Cálculo de Travesaño

$A_{sreq} \text{ (cm}^2\text{)}$	$A_s \text{ (cm}^2\text{)}$
6.085	≤ 9.864

(10) Cálculo de Anclajes Antisísmicos

$A_p \text{ (cm}^2\text{)}$	$R_v \text{ (t)}$
$40.323 \leq 3 \times 3 \times \phi 25 = 44.181$	OK
	50.054

Resultado del diseño

Tipo de Estructura : Estribo

Fecha :

(1) Datos Generales

Número de Puentes:

Nombre del Puente : GRANALLAS A1,A2

De la Ruta, Camino :

Rol Ruta:

En el Cauce :

Región X : LOS LAGOS

Provincia :

Longitud del Puente : L = 56.000 m

Número de Pistas : 2

Ancho : 1.200 + 7.000 + 1.200 = 9.400 m
(Pasillos) (Calzada) (Pasillos)

Pendiente : 1.0, 2.0, 1.0 %

(2) Cargas

Peso específico suelo : $\gamma_s = 1.80 \text{ t/m}^3$ Carga de Hormigón : $w_c = 2.50 \text{ t/m}^3$

Coeficiente de Aceleración de Diseño : A = 0.15

Longitud de Viga : $L_v = 27.925 \text{ m}$, Luz : $L_c = 27.225 \text{ m}$ (Longitud de cálculo)Número de Vigas : $n_v = 4$

Separación entre vigas : S = 2.250 m, 3 @ 2.250 = 6.750 m

Altura de Viga : h = 1.800 m, Ancho de Viga : $b_o = 50.0 \text{ cm}$ Carga de Superestructura : $R_v = 50.05 \text{ t}$, Carga de Tránsito : HS20 - 44
(para 1 apoyo)Carga de superficie : $Q_w = 1.00 \text{ t/m}^2$, Carga de Pavimento : $\gamma_c = 2.30 \text{ t/m}^3$

(3) Material

Hormigón : grado : H-30

 $f_c' = 250 \text{ kg/cm}^2$, $w_c = 145 \text{ pcf} = 2.32 \text{ kg/m}^3$ (AASHTO 8.7.1) $E_c = w_c^{1.5} 33(f_c')^{1/2} = 57000(f_c')^{1/2}$ $= w_c^{1.5} (0.0428)(f_c')^{1/2} = 4729.77(f_c')^{1/2} = 2.5 \times 10^5 \text{ kg/cm}^2$ Acero : A63-42H $f_y = 4200 \text{ kg/cm}^2$, $f_{sa} = 1690 \text{ kg/cm}^2$, $E_s = 2.1 \times 10^6 \text{ kg/cm}^2$ Ángulo de fricción interna relleno : $\phi = 35 \text{ deg}$ Adhesión entre dado y suelo de fundación : $c_B = 0.00 \text{ t/m}^2$ Ángulo de fricción interna suelo de fundación : $\phi_B = 42 \text{ deg}$ Ángulo de fricción entre dado y suelo de fundación : $\delta_B = 30 \text{ deg}$

(4) Geometría

Longitud de Acceso : $L_0 = 4.000 \text{ m}$, Espesor de Acceso : $h_A = 0.250 \text{ m}$

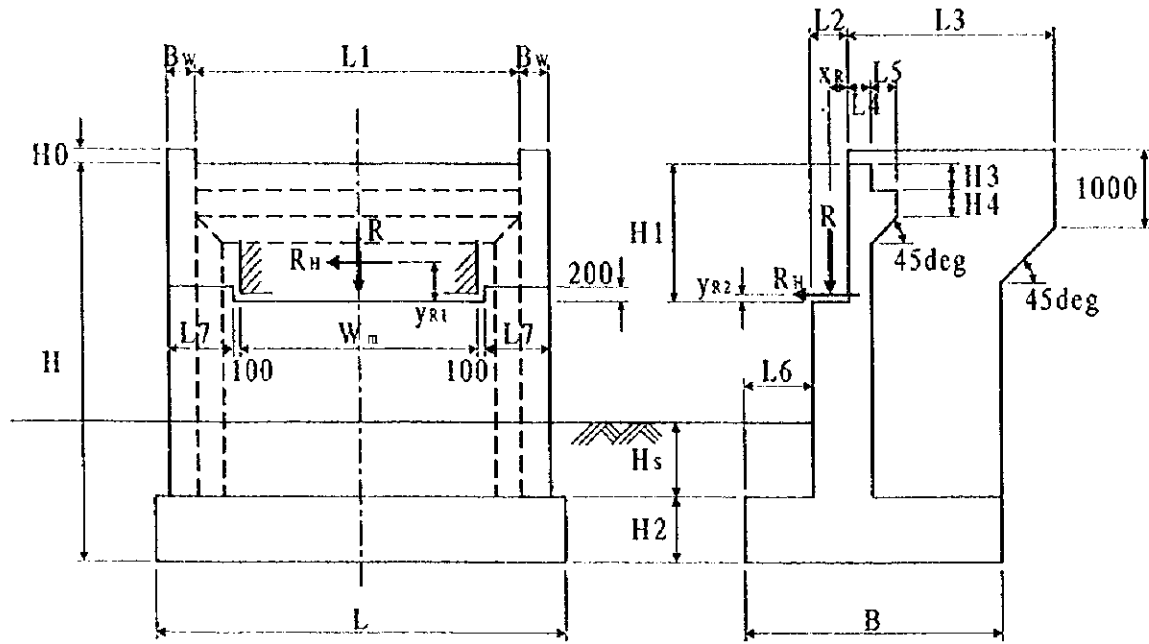

- $B = 5000 \text{ mm}$, $L = 10000 \text{ mm}$, $H = 7000 \text{ mm}$, $H_s = 2000 \text{ mm}$, $W_m = 7250 \text{ mm}$
 $B_w = 450 \text{ mm}$, $y_{R1} = 1600 \text{ mm}$, $y_{R2} = 160 \text{ mm}$, $x_R = 400 \text{ mm}$
 $L1 = 8500 \text{ mm}$, $L2 = 800 \text{ mm}$, $L3 = 3800 \text{ mm}$, $L4 = 400 \text{ mm}$, $L5 = 250 \text{ mm}$
 $L6 = 1200 \text{ mm}$, $L7 = 975 \text{ mm}$
 $H0 = 250 \text{ mm}$, $H1 = 2250 \text{ mm}$, $H2 = 1500 \text{ mm}$, $H3 = 250 \text{ mm}$, $H4 = 250 \text{ mm}$

(5) Arriostamiento de Refuerzo

Recubrimientos mínimos : Fundación 5.0 cm
Elevación 4.0 cm

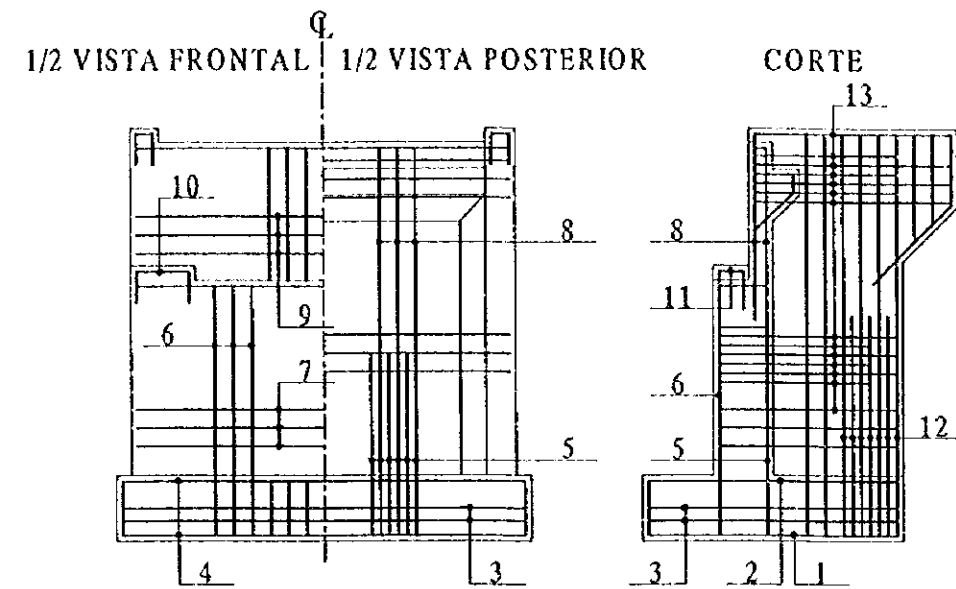

- $1 : \phi 22 @ 250$ $2 : \phi 22 @ 125$ $3 : \phi 18 \text{ n } 3$ $4 : \phi 18 @ 250$ $5 : \phi 18 @ 125$
 $6 : \phi 18 @ 250$ $7 : \phi 16 @ 250$ $8 : \phi 18 @ 250$ $9 : \phi 12 @ 250$ $10 : \phi 18 \text{ n } 4$
 $11 : \phi 18 \text{ n } 4$ $12 : \phi 22 @ 125$ $13 : \phi 22 @ 200$

Suma del Diseño del Estribo

(7) Fuerzas

Caso	e (m)	
Estático	0.303 $\leq B/6 = 0.833$	OK
Sísmico	1.623 $\leq B/3 = 1.667$	OK

(8) Análisis de Estabilidad

Caso	F.S.(S)	$q_{max}(t/m^2)$	$q_{ADM}(t/m^2)$	F.S.(O)	
Estático	4.972 ≥ 1.5	24.55 ≤ 339.92		8.588 ≥ 2.0	OK
Sísmico	1.357 ≥ 1.2	60.86 ≤ 169.20		1.533 ≥ 1.5	OK

(9) Diseño del Muro de Retención

Diseño del refuerzo anterior (Caso estático)

$A_s(cm^2/m)$	M(tm/m)	$M_u(tm/m)$	
9.194 $\leq \phi 18@250=10.180$	4.97 ≤ 13.47		OK

Diseño del refuerzo posterior (Caso sísmico)

$A_s(cm^2/m)$	M(tm/m)	$M_u(tm/m)$	$v(kg/cm^2)$	$v_c(kg/cm^2)$	
1.783 $\leq \phi 18@250=10.180$	1.28 ≤ 13.47		0.4 ≤ 20.0		OK

(10) Diseño del guarda rueda

$A_s(cm^2)$	M(tm)	$M_u(tm)$	$v(kg/cm^2)$	$v_c(kg/cm^2)$	
3.213 $\leq \phi 18n4=10.180$	6.01 ≤ 35.50		0.5 ≤ 20.0		OK

(11) Diseño del Cuerpo del Estribo

Caso	$A_s(cm^2/m)$	$f_t(kg/cm^2)$	$f_{ct}(kg/cm^2)$	$f_t(kg/cm^2)$	$f_{ct}(kg/cm^2)$
Estático	9.123 $\leq \phi 18@125$	1.7 ≤ 100		37.3 ≤ 1690	
Sísmico	8.684 ≤ 20.360	2.2 ≤ 133		58.4 ≤ 2248	

Caso	$v(kg/cm^2)$	$v_c(kg/cm^2)$	
Estático	0.7 ≤ 15.0		OK
Sísmico	0.8 ≤ 20.0		OK

(12) Diseño de Fundaciones

Diseño del dado frontal

Caso	$A_s(cm^2/m)$	M(tm/m)	$M_u(tm/m)$	$v(kg/cm^2)$	$v_c(kg/cm^2)$	
Estático	6.526 $\leq \phi 22@250$	14.22 ≤ 82.47		0.6 ≤ 15.0		OK
Sísmico	11.890 ≤ 15.204	34.46 ≤ 82.47		1.6 ≤ 20.0		OK

Diseño del dado trasero

Caso	$A_s(cm^2/m)$	M(tm/m)	$M_u(tm/m)$	$v(kg/cm^2)$	$v_c(kg/cm^2)$	
Estático	7.257 $\leq \phi 22@125$	15.82 ≤ 163.21		0.6 ≤ 15.0		OK
Sísmico	18.197 ≤ 30.408	52.74 ≤ 163.21		2.0 ≤ 20.0		OK

(13) Diseño del Muro Ala

	Caso	$A_s(cm^2/m)$	M(tm/m)	$M_u(tm/m)$	$v(kg/cm^2)$	$v_c(kg/cm^2)$	
a	Estático	12.015 $\leq \phi 22@200$	7.40 ≤ 28.10		1.3 ≤ 15.0		OK
	Sísmico	6.740 ≤ 19.005	5.52 ≤ 28.10		0.9 ≤ 20.0		OK
b	Estático	17.059 $\leq \phi 22@200$	10.51 ≤ 28.10		2.0 ≤ 15.0		OK
	Sísmico	11.112 ≤ 19.005	9.11 ≤ 28.10		1.7 ≤ 20.0		OK
b'	Estático	5.869 $\leq \phi 22@400$	3.62 ≤ 14.39		1.4 ≤ 15.0		OK
	Sísmico	3.984 ≤ 9.503	3.27 ≤ 14.39		1.2 ≤ 20.0		OK
c	Estático	21.337 $\leq \phi 22@125$	13.15 ≤ 43.67		2.7 ≤ 15.0		OK
	Sísmico	14.329 ≤ 30.408	11.74 ≤ 43.67		2.5 ≤ 20.0		OK
c'	Estático	6.404 $\leq \phi 22@250$	3.95 ≤ 22.70		1.5 ≤ 15.0		OK
	Sísmico	4.386 ≤ 15.204	3.59 ≤ 22.70		1.4 ≤ 20.0		OK
d	Estático	0.396 $\leq \phi 22@400$	0.24 ≤ 14.39		0.2 ≤ 15.0		OK
	Sísmico	0.183 ≤ 9.503	0.15 ≤ 14.39		0.1 ≤ 20.0		OK

Resultado del diseño

Tipo de Estructura : Cepa

Fecha :

(1) Datos Generales

Nombre del Puente : GRANALLAS P1
 De la Ruta, Camino :
 En el Cauce :
 Región : X : LOS LAGOS
 Provincia :
 Longitud del Puente : L = 56.000 m
 Número de Pistas : 2
 Ancho : 1.200 + 7.000 + 1.200 = 9.400 m
 (Pasillos) (Calzada) (Pasillos)
 Pendiente : 1.0, 2.0, 1.0 %

Número de Puente :

Rol Ruta :

(2) Cargas

Peso específico suelo : $\gamma_s = 2.00 \text{ t/m}^3$
 Cargas de Hormigón : $w_c = 2.50 \text{ t/m}^3$
 Coeficiente de Aceleración de Diseño : A = 0.15
 Longitud de Viga : $L_v = 27.925 \text{ m}$, $Luz : L_c = 27.225 \text{ m}$ (Longitud de cálculo)
 Número de Vigas : $n_v = 4$
 Separación entre vigas : $S = 2.250 \text{ m}$, $3 @ 2.250 = 6.750 \text{ m}$
 Ancho de Viga : $b_v = 50.0 \text{ cm}$
 Carga de Superestructura : $R_v = 50.05 \text{ t}$ (para 1 apoyo)
 Cargas de Tránsito : HS20 - 44
 Altura de la Superestructura : $H_v = 1.850 \text{ m}$
 Carga de viento sobre Superestructura : $W_v = 0.244 \text{ t/m}^2$
 Carga de viento sobre infraestructura : $W_E = 0.244 \text{ t/m}^2$
 Velocidad del cauce : $V = 2.000 \text{ m/s}$

(3) Material

Hormigón : H-30 $f'_c = 250 \text{ kg/cm}^2$, $w_c = 145 \text{ pcf} = 2.32 \text{ kg/m}^3$ (AASHTO 8.7.1)
 $E_c = w_c^{1.5} 33(f'_c)^{1/2} = 57000(f'_c)^{1/2}$
 $= w_c^{1.5} (0.0428)(f'_c)^{1/2} = 4729.77(f'_c)^{1/2} = 2.5 \times 10^5 \text{ kg/cm}^2$
 Acero : A63-42H $f_y = 4200 \text{ kg/cm}^2$, $f_u = 1690 \text{ kg/cm}^2$, $E_s = 2.1 \times 10^6 \text{ kg/cm}^2$
 Adhesión entre dado y suelo de fundación : $c_B = 0.00 \text{ t/m}^2$
 Ángulo de fricción interna suelo de fundación : $\phi_B = 42 \text{ deg}$
 Ángulo de fricción entre dado y suelo de fundación : $\delta_B = 30 \text{ deg}$

(4) Geometría

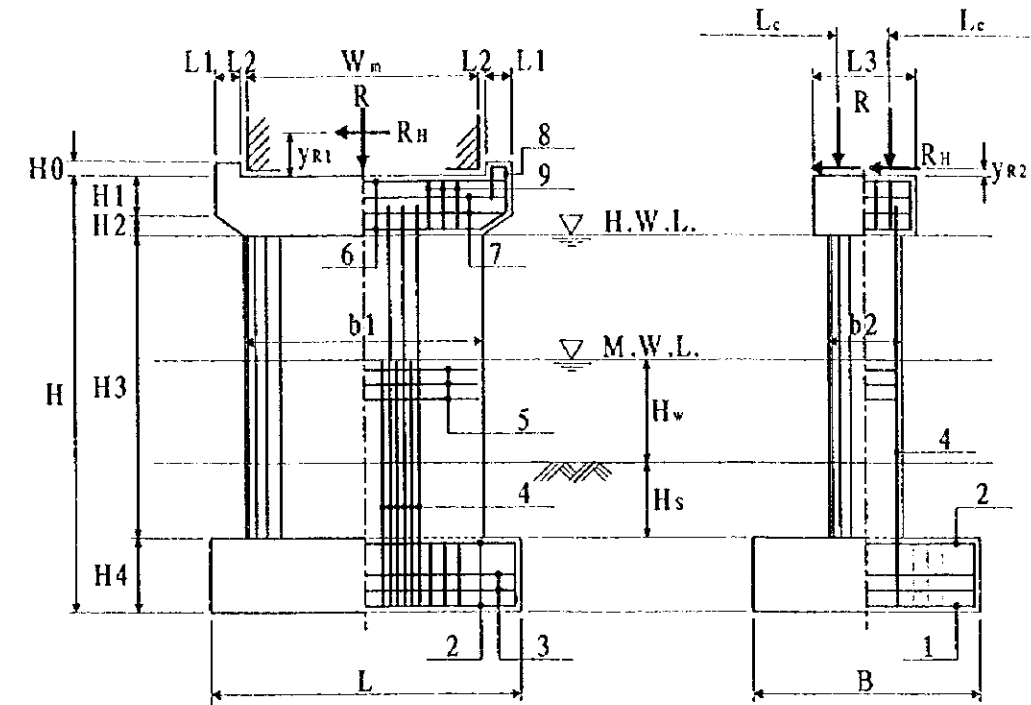

B = 6300 mm, L = 8000 mm, H = 6500 mm, $H_s = 2000 \text{ mm}$, $H_w = 1000 \text{ mm}$
 $y_{R1} = 1600 \text{ mm}$, $y_{R2} = 160 \text{ mm}$, L1 = 500 mm, L2 = 100 mm, L3 = 1800 mm
 $b_1 = 7400 \text{ mm}$, $b_2 = 1000 \text{ mm}$, $W_m = 7250 \text{ mm}$, $H_0 = 300 \text{ mm}$
 $H_1 = 500 \text{ mm}$, $H_2 = 200 \text{ mm}$, $H_3 = 4200 \text{ mm}$, $H_4 = 1600 \text{ mm}$

Arriostamiento de Refuerzo

Recubrimientos mínimos : Fundación 5.0 cm
 Elevación 4.0 cm

1 : $\phi 25 @ 125$, 2 : $\phi 25 @ 250$, 3 : $\phi 22 \text{ n } 4$, 4 : $\phi 25 @ 110$
 5 : $\phi 22 @ 300$, 6 : $\phi 22 \text{ n } 5$, 7 : $\phi 22 \text{ n } 2$, 8 : $\phi 25 \text{ n } 6$
 9 : $\phi 16 @ 250$

Suma del Diseño de la Cepa

(6) Fuerzas

Longitudinal :

Caso	e_B (m)	
Sísmico	2.066 $\leq B/3 = 2.100$	OK

Transversal :

Caso	e_L (m)	
Estático	0.140 $\leq L/6 = 1.333$	OK
Sísmico	2.286 $\leq L/3 = 2.667$	OK

(7) Análisis de Estabilidad

Longitudinal :

Caso	F.S.(S)	$q_{max}(t/m^2)$	$q_{all}(t/m^2)$	F.S.(O)	
Estático		28.43 \leq	573.97		OK
Sísmico	1.770 ≥ 1.2	53.02 \leq	293.09	1.525 ≥ 1.5	OK

Transversal :

Caso	F.S.(S)	$q_{max}(t/m^2)$	$q_{all}(t/m^2)$	F.S.(O)	
Estático	32.767 ≥ 1.5	16.62 \leq	557.09	28.495 ≥ 2.0	OK
Sísmico	1.769 ≥ 1.2	42.58 \leq	346.80	1.750 ≥ 1.5	OK

(8) Diseño del guarda rueda

A_s (cm ²)	M(tm)	M_u (tm)	v (kg/cm ²)	v_c (kg/cm ²)	
24.494 $\leq \phi 25 \text{ n } 6 = 29.454$	22.52 \leq	49.41	9.1 \leq	20.0	OK

(9) Diseño de la cepa

A_s (cm ²)	f_c (kg/cm ²)	f_s (kg/cm ²)	f_c (kg/cm ²)	f_s (kg/cm ²)
271.888 $\leq \phi 25 @ 110 = 294.540$	62.6 \leq	133	1529.8 \leq	2248

v (kg/cm ²)	v_c (kg/cm ²)	
1.8 \leq	20.0	OK

(10) Diseño de Fundaciones

Caso	A_s (cm ² /m)	M(tm/m)	M_u (tm/m)	v (kg/cm ²)	v_c (kg/cm ²)	
Estático	36.815 $\leq \phi 25 @ 125 = 39.272$	85.76 \leq	224.33	2.9 \leq	15.0	OK
Sísmico	39.229 $\leq \phi 25 @ 125 = 39.272$	121.55 \leq	224.33	4.1 \leq	20.0	OK

RESUMEN DE CUBICACIONES
Puente N° 2

Nombre del Puente: Granallas

Superestructura

Material (Ítem de Construcción)	Grado	Unidad	Cantidades				Comentarios
			A1	P1	A2	Total	
Superestructura							
Hormigón	H-25	m ³				89.3	Losa, Viga Travesaño
	H-35	m ³				77.9	Viga
Acero	A63-42H	kg				23,695.2	
	A44-28H	kg				382.9	Viga travesaño
PC Cable	ASTM416-80	m				445.1	
Accesorios		n°				32.0	
Moldaje		m ²				831.7	Losa, Viga Travesaño, Viga
Andamios		m ²				507.6	Para la losa de hormigón
Zapata		n°	4.0	8.0	4.0	16.0	
Cantonera		m	9.4		9.4	18.8	
Baranda		m				112.0	
Drenaje		n°					
Pasillo		m ²				134.4	
Pavimento		m ²				392.0	

Losa de Acceso

Material (Ítem de Construcción)	Grado	Unidad	Cantidades				Comentarios
			A1	P1	A2	Total	
Hormigón	H-25	m ³	7.0		7.0	14.0	
Acero	A44-28	kg	320.5		320.5	640.9	
Moldaje		m ²	3.8		3.8	7.5	

Infraestructura y otros

Material (Ítem de Construcción)	Grado	Unidad	Cantidades				Comentarios
			A1	P1	A2	Total	
Infraestructura							
Hormigón	H-25	m ³	272.5	243.6	272.5	788.6	
Acero	A63-42H	kg	14,228.8	20,965.4	14,228.8	49,423.0	
Moldaje		m ²	448.1	272.5	448.1	1,168.6	
Excavación		m ³	748.0	364.5	704.0	1,816.5	
Horm. Emplant.		m ³	5.8	5.9	5.8	17.5	
Andamios		m ³	186.0	98.0	186.0	470.0	

Camino de Acceso

Material (Ítem de Construcción)	Grado	Unidad	Cantidades				Comentarios
			A1	P1	A2	Total	
Terraplén		m ³	0.0		0.0	0.0	
Base		m ³	0.0		0.0	0.0	
Pavimento		m ²	28.0		28.0	56.0	

Cubicaciones

Fecha : _____ Número de Puente : _____
 Nombre del Puente : GRANALLAS
 De la Ruta, Camino : _____ Rol Ruta : _____
 En el Cauce : _____
 Región : X: LOS LAGOS Provincia : _____
 Longitud del Puente : L = 56 m
 Número de Pistas : 2
 Ancho : 1.20+7.00+1.20 = 9.40 m
 Pendiente : 1.0% (Pasillos) 1.5% (Calzada)
 Tipo de Estructura : Postensado
 Longitud de Viga : Lv = 27.93 m
 Luz : Lc = 27.23 m
 Número de Vigas : n_v = 4
 Separación entre Vigas : S = 2.25 m
 Ancho Mesa Mínima : Wm = 7.75 m

Materia	Grado	Unidad	Cantidad		Observación
			(Para 1 Viga)	(Para Puente)	
Losa					
Hormigón	H-25	m ³	-----	79.55	
Moldaje		m ²	-----	221.68	
Acero	A63-42H	kg	-----	15,995.64	
Travesaño Intermedio					
Hormigón	H-25	m ³	-----	4.44	
Moldaje		m ²	-----	38.15	
Acero	A44-28H	kg	-----	382.88	
Travesaño Extremos					
Hormigón	H-25	m ³	-----	5.27	
Moldaje		m ²	-----	38.27	
Acero	A63-42H	kg	-----	630.80	
Viga			Exterior	Interior	
Hormigón	H-35	m ³	19.47	19.47	77.87
Moldaje		m ²	133.39	133.39	533.55
Acero	A63-42H	kg	1,742.23	1,792.14	7,068.75
PC Cable	ASTMA416-80	m	111.27	111.27	445.08
Anclaje		grupo	8	8	32

Tipo de Barras para hormigón

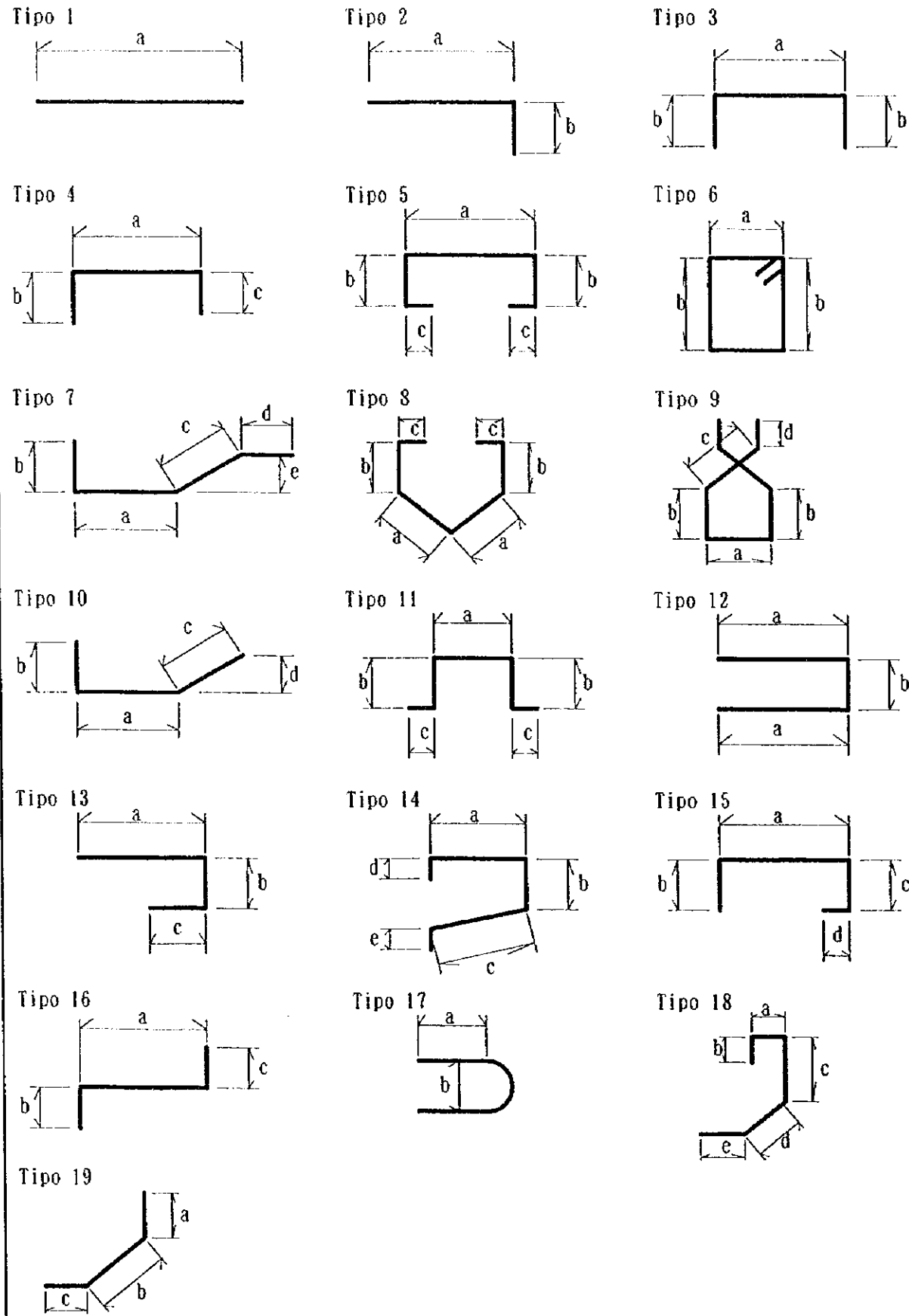

Marca	Dia. (mm)	Unit W. (kg/m)	Tipo	Dimensiones (mm)					Largos (mm)	Peso/Par. (kg)	Cant. Requ.	Peso Total (kg)	Obs.
				a	b	c	d	e					
1	16	1.578	1	9340					9340	14.74	189	2,785.58	
2	16	1.578	1	7050					7050	11.12	186	2,069.23	
3	16	1.578	3	9340	110				9560	15.09	187	2,821.02	
4	16	1.578	7	1858	110	156	150	110	2274	3.59	372	1,334.87	
5	16	1.578	20	1125	110	156	150		1737	2.74	372	1,019.65	
6	16	1.578	6	140	409				1337	2.11	374	789.06	
7	16	1.578	14	349	96	357	136	136	1073	1.69	374	633.25	
8	16	1.578	2	795	210				1005	1.59	40	63.44	
9	16	1.578	1	1250					1250	1.97	60	118.35	
10	12	0.888	3	27865	360				28585	25.38	78	1,979.91	
11	12	0.888	1	27865					27865	24.74	8	197.95	
12	12	0.888	1	27865					27865	24.74	78	1,930.04	
13	12	0.888	1	1210					1210	1.07	152	163.32	
14	12	0.888	7	1466	102	665	180	210	2412	2.14	42	89.96	
15	12	0.888	1	1750					1750	1.55	72	111.89	
16	22	2.984	1	1750					1750	5.22	12	62.66	
17	12	0.888	6	200	1665				3910	3.47	60	208.32	
18	12	0.888	1	1750					1750	1.55	84	130.54	
19	22	2.984	1	1750					1750	5.22	12	62.66	
20	12	0.888	6	250	1915				4510	4.00	60	240.29	
21	12	0.888	3	27875	180				28235	25.07	24	601.74	
22	12	0.888	3	27875	180				28235	25.07	40	1,002.91	
23	10	0.617	1	25825					25825	15.93	48	764.83	
24	10	0.617	10	1572	450	1237	300		3259	2.01	96	193.04	
25	10	0.617	3	950	400				1750	1.08	48	51.83	
26	12	0.888	11	1915	150	102			2419	2.15	556	1,194.33	
27	12	0.888	9	450	219	584	180		2413	2.14	492	1,054.23	
28	12	0.888	8	508	273	102			1764	1.57	556	870.94	
29	12	0.888	5	300	1915	102			4334	3.85	16	61.58	Var
30	12	0.888	5	450	1750	102			4154	3.69	64	236.08	
31	12	0.888	3	950	102				1154	1.02	556	569.76	
32	12	0.888	3	1750	180				2110	1.87	16	29.98	
33	12	0.888	2	1750	75				1825	1.62	32	51.86	
34	12	0.888	1	1460					1460	1.30	48	62.23	
35	22	2.984	1	2260					2260	6.74	8	53.95	
36	12	0.888	1	805					805	0.71	48	34.31	
37	22	2.984	1	1205					1205	3.60	8	28.77	
38	12	0.888	1	1460					1460	1.30	56	72.60	
39	22	2.984	1	2260					2260	6.74	8	53.95	
40	12	0.888	1	955					955	0.85	56	47.49	
41	22	2.984	1	1355					1355	4.04	8	32.35	
42	25	3.853	1	2845					2845	10.96	18	197.31	

Cubicaciones

Fecha : _____ Número de Puente : _____

Nombre del Puente : GRANALLAS A1,A2

De la Ruta, Camino : _____ Rol Ruta : _____

En el Cauce : _____

Región : X : LOS LAGOS Provincia : _____

Longitud del Puente : L = 56.00 m

Número de Pistas : 2

Ancho : 1.20+7.00+1.20 = 9.40 m

Pendiente : 1.0% (Pasillos) 1.5% (Calzada)

Tipo de Estructura : **Estribo**

Altura de Estribo : H = 7.00 m

Longitud de Viga : Lv = 27.93 m

Luz : Lc = 27.23 m

Número de Vigas : n_v = 4.00

Separación entre Vigas : S = 2.25 m

Ancho Mesa Mínima : Wm = 7.25 m

Materia	Grado	Unidad	Cantidad	Observación
Espaldar				
Hormigón	H-25	m ³	9.25	
Moldaje		m ²	42.45	
Acero	A63-42H	kg	770.03	
Muro				
Hormigón	H-25	m ³	37.13	
Moldaje		m ²	65.38	
Acero	A63-42H	kg	1,771.58	
Fundación				
Hormigón	H-25	m ³	75.00	
Moldaje		m ²	45.00	
Acero	A63-42H	kg	3,694.43	
Muros				
Hormigón	H-25	m ³	14.87	
Moldaje		m ²	71.20	
Acero	A63-42H	kg	1,743.07	
Total				
Hormigón	H-25	m ³	136.24	
Moldaje		m ²	224.03	
Acero	A63-42H	kg	7,979.11	

Tipo de Barras para hormigón

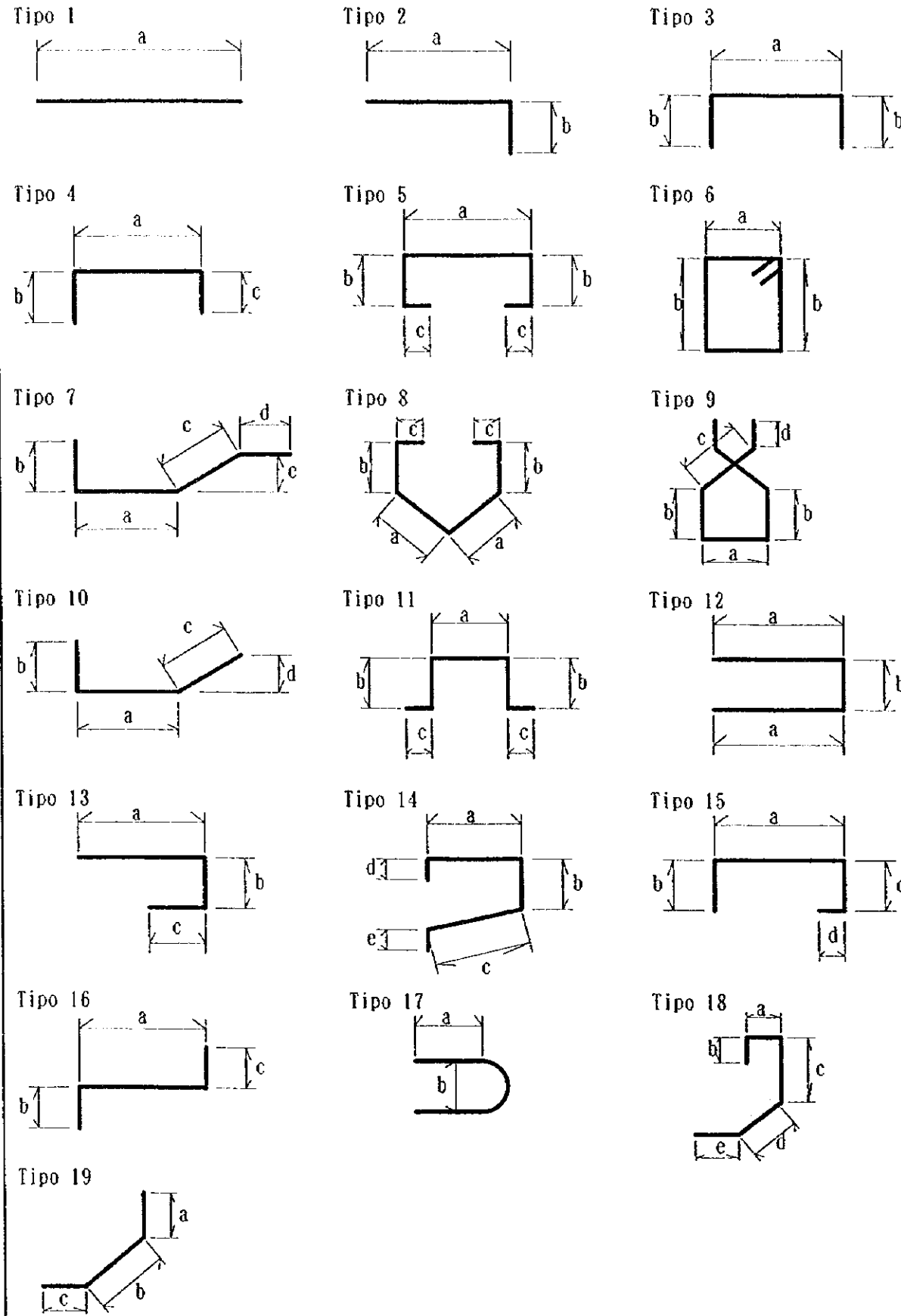

Marca	Dia. (mm)	Unit W. (kg/m)	Tipo	Dimensiones (mm)					Largos (mm)	Peso/Par. (kg)	Cant. Requ	Peso Total (kg)	Obs.
				a	b	c	d	e					
1	22	2.984	3	4900	1400				7700	22.98	41	942.05	
2	22	2.984	3	4900	770				6440	19.22	81	1,556.57	
3	18	1.998	3	9900	1400				12700	25.37	21	532.87	
4	18	1.998	3	9900	630				11160	22.30	21	468.25	
5	18	1.998	3	9900	360				10620	21.22	6	127.31	
6	18	1.998	3	4900	360				5620	11.23	6	67.37	
7	16	1.578	1	9320					9320	14.71	16	235.31	
8	16	1.578	1	9320					9320	14.71	16	235.31	
9	18	1.998	2	4660	270				4930	9.85	39	384.16	
10	18	1.998	2	3435	270				3705	7.40	38	281.30	
11	18	1.998	2	4660	270				4930	9.85	39	384.16	
12	16	1.578	3	9320	240				9800	15.46	6	92.79	
13	18	1.998	3	1120	270				1660	3.32	30	99.50	
14	18	1.998	3	895	520				1935	3.87	8	30.93	
15	18	1.998	3	720	520				1760	3.52	8	28.13	
16	12	0.888	1	9320					9320	8.28	9	74.49	
17	18	1.998	1	2840					2840	5.67	39	221.30	
18	12	0.888	1	9320					9320	8.28	7	57.93	
19	18	1.998	1	2840					2840	5.67	39	221.30	
20	12	0.888	1	9320					9320	8.28	3	24.83	
21	18	1.998	14	570	194	807	270	153	1993	3.98	33	131.41	
22	12	0.888	1	9320					9320	8.28	2	16.55	
23	12	0.888	3	370	390				1150	1.02	4	4.08	
24	12	0.888	3	320	102				524	0.47	39	18.15	
25	22	2.984	2	3720	330				4050	12.09	18	217.53	
26	22	2.984	2	2920	330				3250	9.70	4	38.79	
27	22	2.984	2	3320	330				3650	10.89	2	21.78	
28	22	2.984	2	3720	330				4050	12.09	8	96.68	
29	22	2.984	2	2900	330				3230	9.64	10	96.38	
30	22	2.984	2	2920	330				3250	9.70	12	116.38	
31	22	2.984	2	3190	330				3520	10.50	12	126.04	
32	22	2.984	2	7160	330				7490	22.35	22	491.70	
33	12	0.888	3	370	1444				3257	2.89	6	17.35	Var
34	12	0.888	10	944	180	1372	970		2495	2.22	4	8.86	
35	12	0.888	2	3720	180				3900	3.46	18	62.34	
36	12	0.888	2	2920	180				3100	2.75	4	11.01	
37	12	0.888	2	3320	180				3500	3.11	2	6.22	
38	12	0.888	2	3720	180				3900	3.46	8	27.71	
39	12	0.888	2	7160	180				7340	6.52	22	143.39	
40	12	0.888	2	4660	180				4840	4.30	8	34.38	
41	22	2.984	2	2494	330				2824	8.43	18	151.68	
42	22	2.984	2	1363	330				1693	5.05	10	50.52	
43	12	0.888	2	370	102				472	0.42	28	11.74	
44	12	0.888	2	370	102				472	0.42	30	12.57	

Cubicaciones

Fecha : _____ Número de Puente : _____
 Nombre del Puente : GRANALLAS P1
 De la Ruta, Camino : _____ Rol Ruta : _____
 En el Cauce : _____
 Región : X : LOS LAGOS Provincia : _____
 Longitud del Puente : L = 56.00 m
 Número de Pistas : 2
 Ancho : 1.20+7.00+1.20 = 9.40 m
 Pendiente : 1.0% (Pasillos) 1.5% (Calzada)
 Tipo de Estructura : Cepa
 Altura de Cepa : H = 6.50 m
 Longitud de Viga : Lv = 27.93 m
 Luz : Lc = 27.23 m
 Número de Vigas : n_v = 4.00
 Separación entre Vigas : S = 2.25 m
 Ancho Mesa Mínima : Wm = 7.25 m

Materia	Grado	Unidad	Cantidad	Observación
Cabezal				
Hormigón	H-25	m ³	11.00	
Moldaje		m ²	23.54	
Acero	A63-42H	kg	696.14	
Columna				
Hormigón	H-25	m ³	30.18	
Moldaje		m ²	66.95	
Acero	A63-42H	kg	4034.36	
Fundación				
Hormigón	H-25	m ³	80.64	
Moldaje		m ²	45.76	
Acero	A63-42H	kg	5752.20	
Total				
Hormigón	H-25	m³	121.82	
Moldaje		m²	136.25	
Acero	A63-42H	kg	10482.69	

