

**SULTANATE OF OMAN**  
**MINISTRY OF COMMUNICATIONS**  
**DIRECTORATE GENERAL OF ROADS**

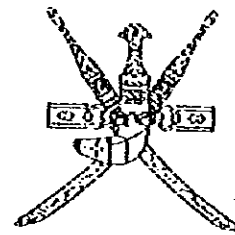

**CONSTRUCTION OF PEDESTRIAN UNDERPASS**  
**AT**  
**ASRAR BANI SA'D**  
**BATINAH HIGHWAY**

**TENDER DOCUMENT**

**DRAWINGS**

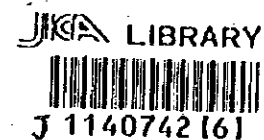

**PACIFIC CONSULTANTS INTERNATIONAL**  
**FUKUYAMA CONSULTANTS INTERNATIONAL**

March, 1997

SSF
CR(5)
97-015

**DRAWING SCHEDULE**  
**(PU12-ASRAR BANI SA'D PEDESTRIAN UNDERPASS)**

SHEET NO.	DRAWING TITLE
<b>G</b>	
<b>GENERAL</b>	
G - 1	Drawing Schedule
<b>P</b>	
<b>PEDESTRIAN UNDERPASS</b>	
P - 1	General View (1)
P - 2	General View (2)
P - 3	General View (3)
P - 4	Re-bar Arrangement (1)
P - 5	Re-bar Arrangement (2)
P - 6	Re-bar Arrangement (3)
P - 7	Re-bar Arrangement (4)
P - 8	Re-bar Arrangement (5)
P - 9	Re-bar Arrangement (6)
P - 10	Re-bar Arrangement (7)
P - 11	Re-bar Arrangement (8)
P - 12	Re-bar Arrangement (9)
P - 13	Re-bar Arrangement (10)
<b>T</b>	
<b>TEMPORARY WORKS</b>	
T - 1	Construction Sequence
T - 2	Detour Layout

NOTES:		JAPAN INTERNATIONAL COOPERATION AGENCY (JICA)	CLIENT : MINISTRY OF COMMUNICATIONS, DIRECTORATE GENERAL OF ROADS
		JICA STUDY TEAM	PROJECT : D/D ON ROAD DEVELOPMENT PROJECT ON BATINAH HIGHWAY
		PACIFIC CONSULTANTS INTERNATIONAL FUKUYAMA CONSULTANTS INTERNATIONAL	TITLE : PU-12, ASRAR BANI SA'D DRAWING SCHEDULE
			DATE : _____ DWG NO. G-1

THE UNIVERSITY OF CHICAGO

PHYSICS DEPARTMENT

PHYSICS 230

LECTURE 1

MECHANICS

LECTURE 2

LECTURE 3



1140742 (6)





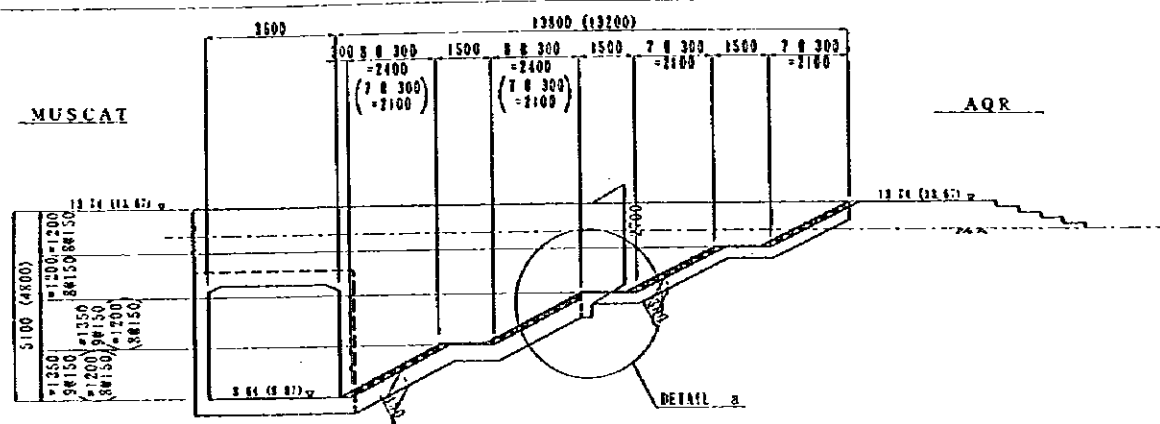

STAIR (SECTION A-A)  
SCALE 1/200

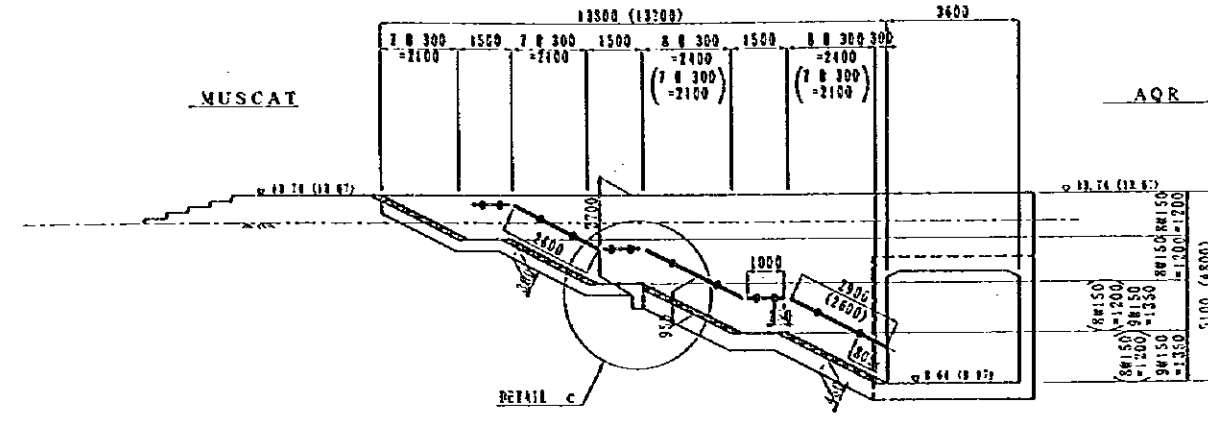

STAIR HANDRAIL (SECTION B-B)  
SCALE 1/200

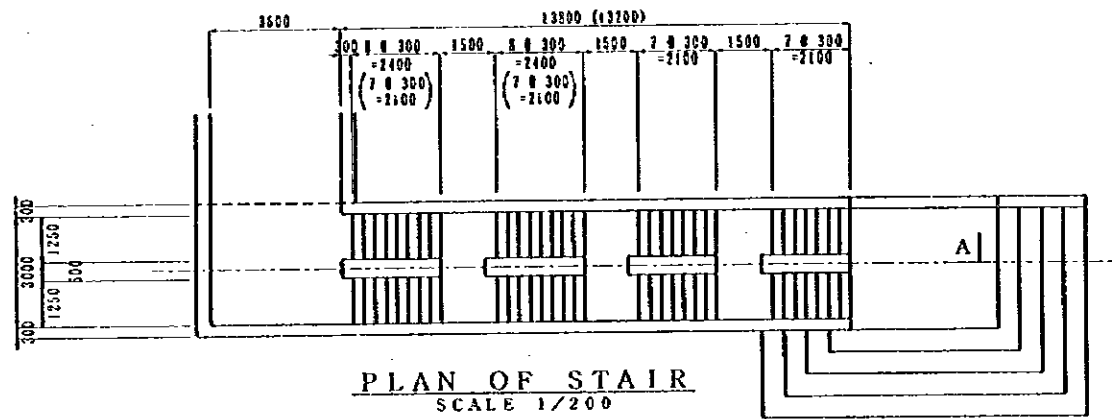

PLAN OF STAIR  
SCALE 1/200

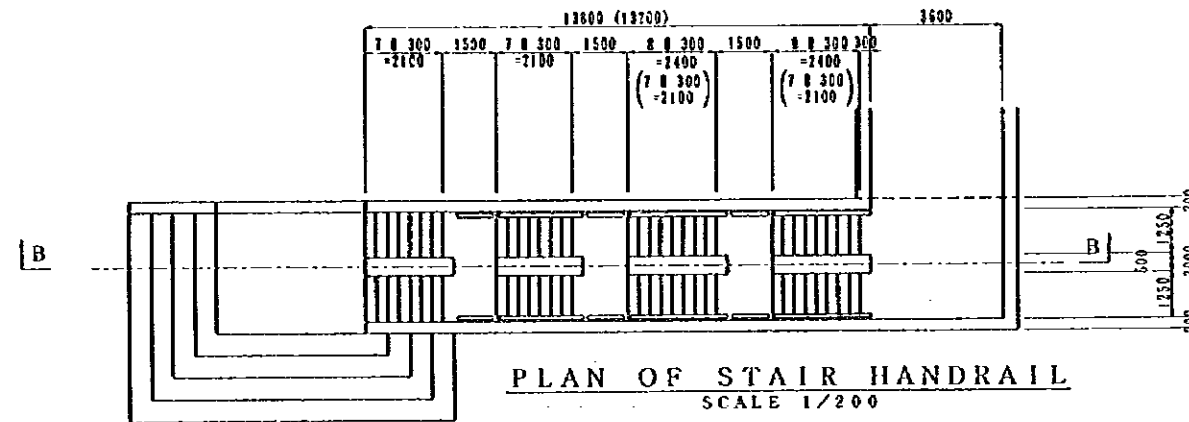

PLAN OF STAIR HANDRAIL  
SCALE 1/200

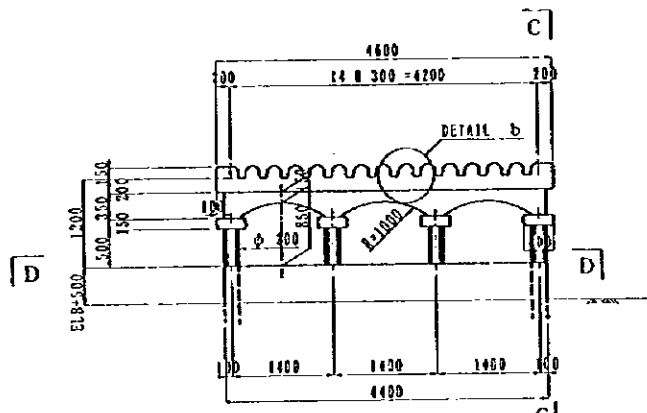

SIDE ELEVATION  
SCALE 1/100

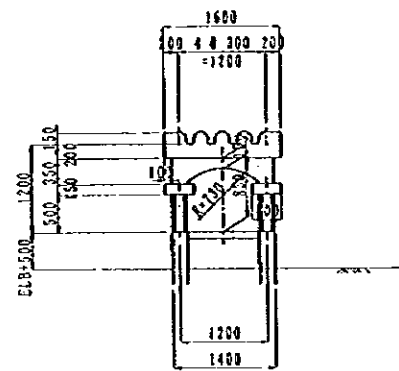

SECTION C-C  
SCALE 1/100

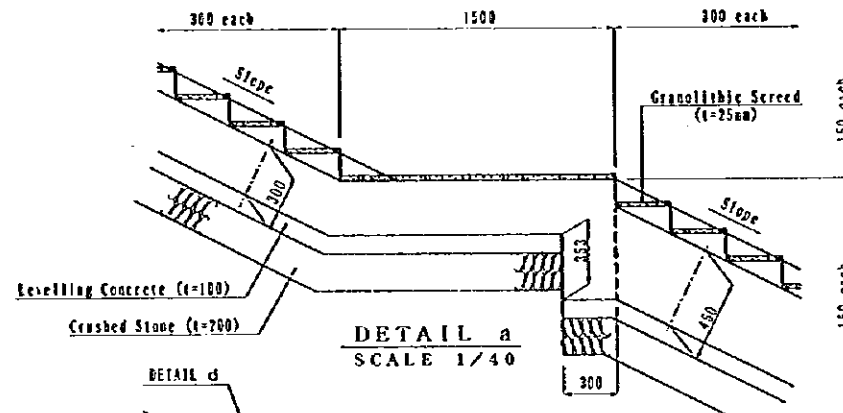

DETAIL a  
SCALE 1/40

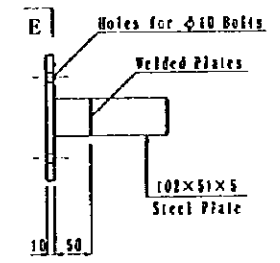

DETAIL d  
SCALE 1/10

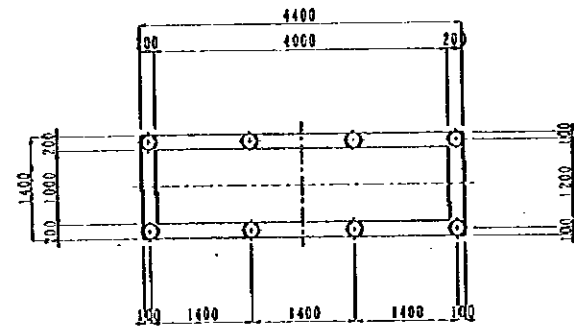

SECTION D-D  
SCALE 1/100

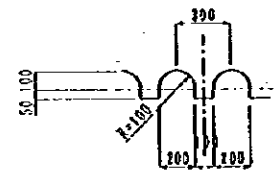

DETAIL b  
SCALE 1/40

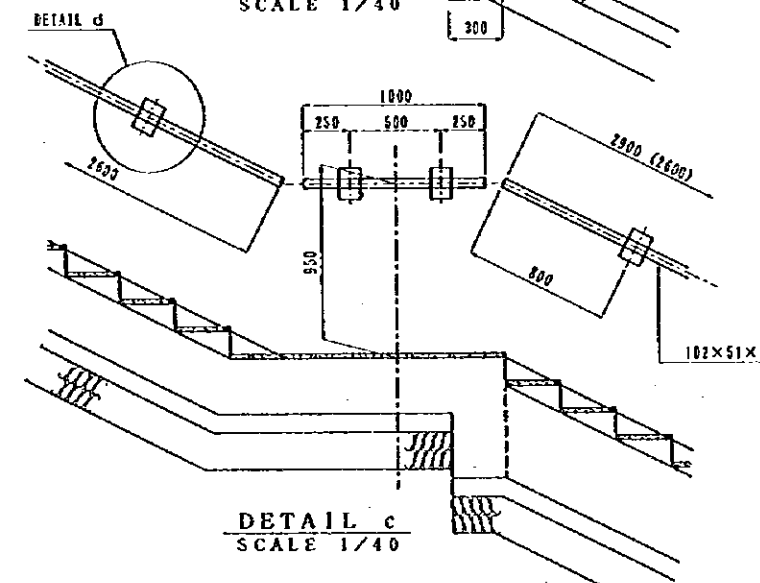

DETAIL c  
SCALE 1/40

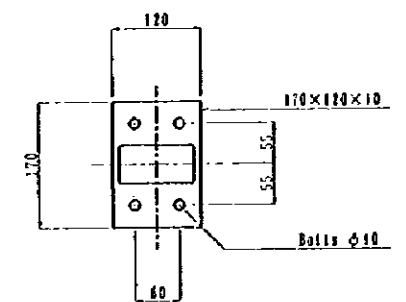

SECTION E-E  
SCALE 1/10

CANOPY ON LIGHT WELL

NOTES: Dimensions of ( ) value are for inland stair.

JAPAN INTERNATIONAL COOPERATION AGENCY  
(JICA)  
JICA STUDY TEAM  
PACIFIC CONSULTANTS INTERNATIONAL  
FLUKYAMA CONSULTANTS INTERNATIONAL

CLIENT : MINISTRY OF COMMUNICATIONS, DIRECTORATE GENERAL OF ROADS  
PROJECT : D/D ON ROAD DEVELOPMENT PROJECT ON BATINAH HIGHWAY  
TITLE : P/U-12, ASRAR BANI SA'D GENERAL VIEW (2)  
DATE :  
DWG NO. P-2

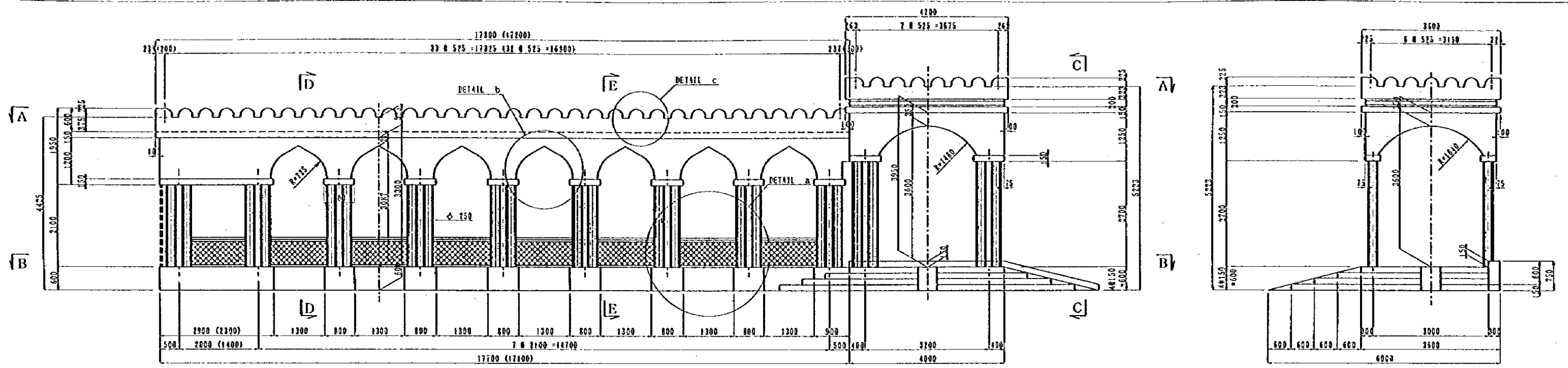

**PROFILE OF CANOPY**  
SCALE 1/100

**ENTRANCE (C-C)**  
SCALE 1/100

**PLAN (A-A)**  
SCALE 1/100

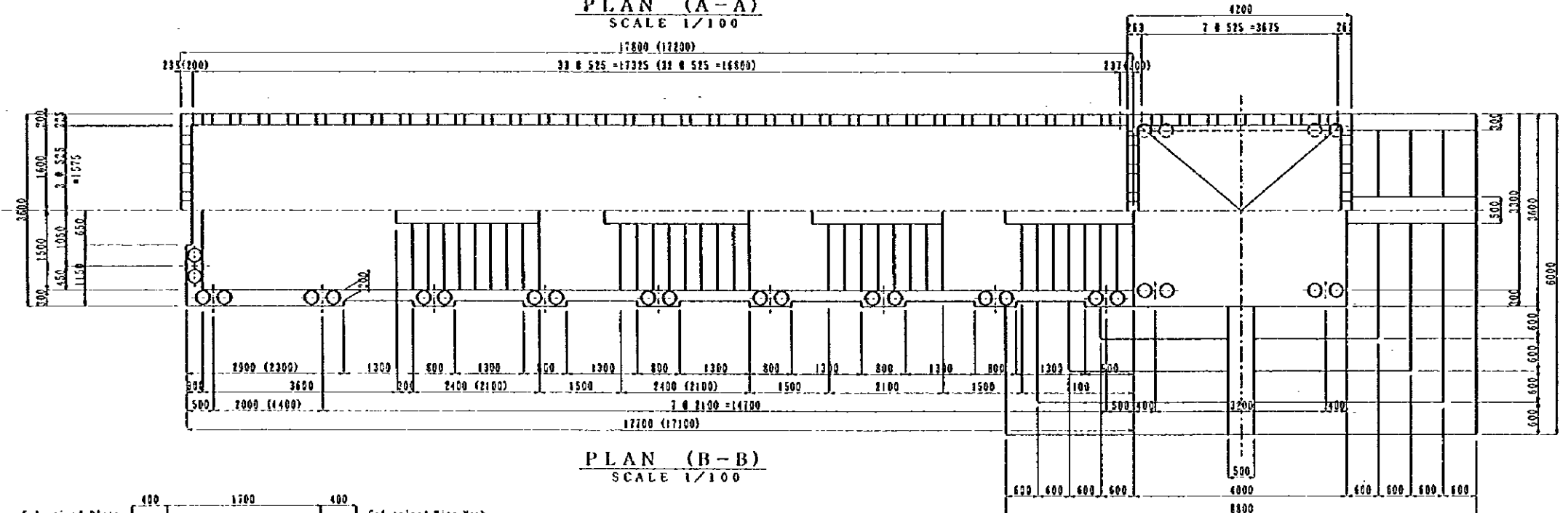

**PLAN (B-B)**  
SCALE 1/100

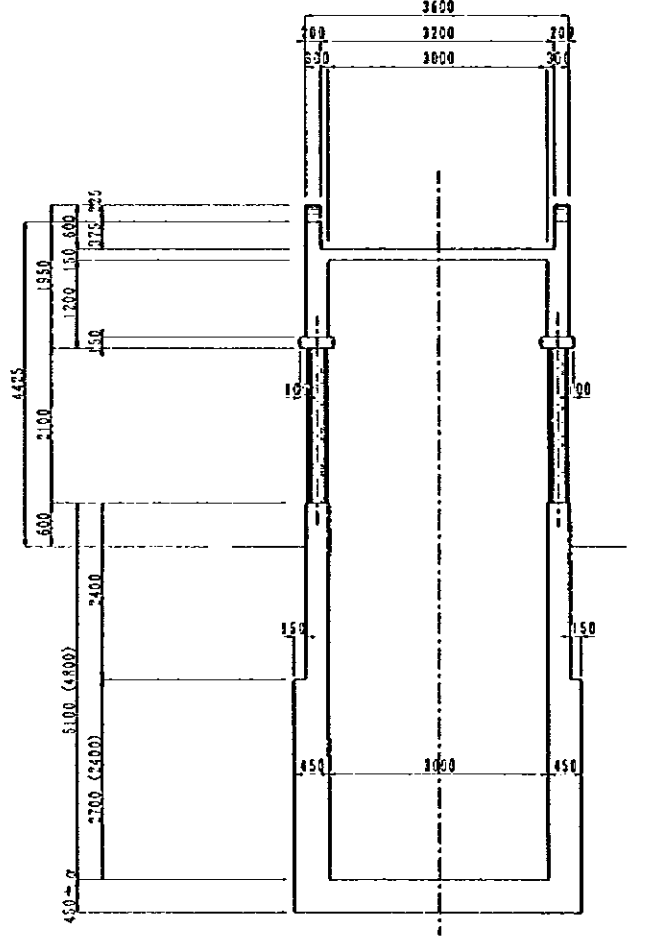

**CROSS SECTION D-D**  
SCALE 1/100

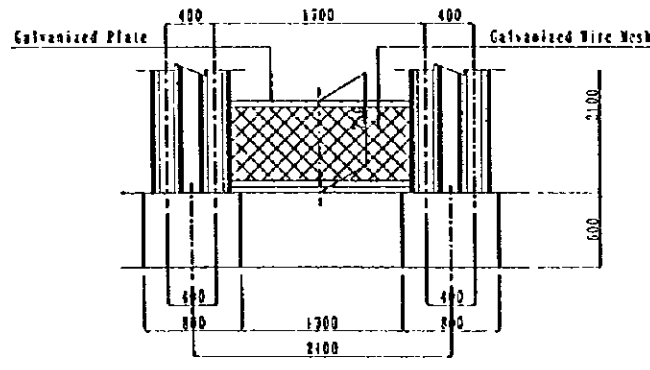

**DETAIL a**  
SCALE 1/60

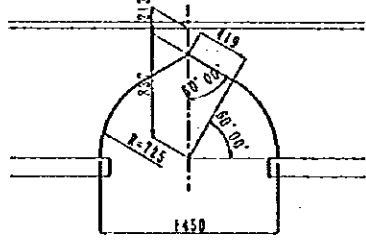

**DETAIL b**  
SCALE 1/60

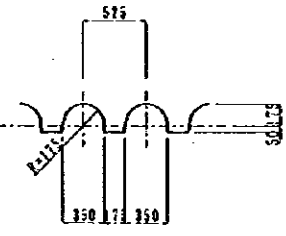

**DETAIL c**  
SCALE 1/60

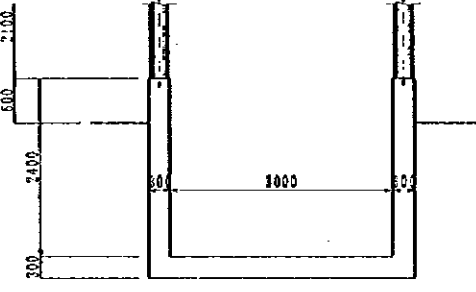

**CROSS SECTION E-E**  
SCALE 1/100

NOTES: Dimensions of ( ) value are for inland stair.

JAPAN INTERNATIONAL COOPERATION AGENCY  
(JICA)  
JICA STUDY TEAM  
PACIFIC CONSULTANTS INTERNATIONAL  
FUKUYAMA CONSULTANTS INTERNATIONAL

CLIENT : MINISTRY OF COMMUNICATIONS, DIRECTORATE GENERAL OF ROADS  
PROJECT : D/D ON ROAD DEVELOPMENT PROJECT ON BATINAH HIGHWAY  
TITLE : P/U-12, ASRAR BANI SA'D GENERAL VIEW (3)  
DATE :  
DWG NO. P- 3

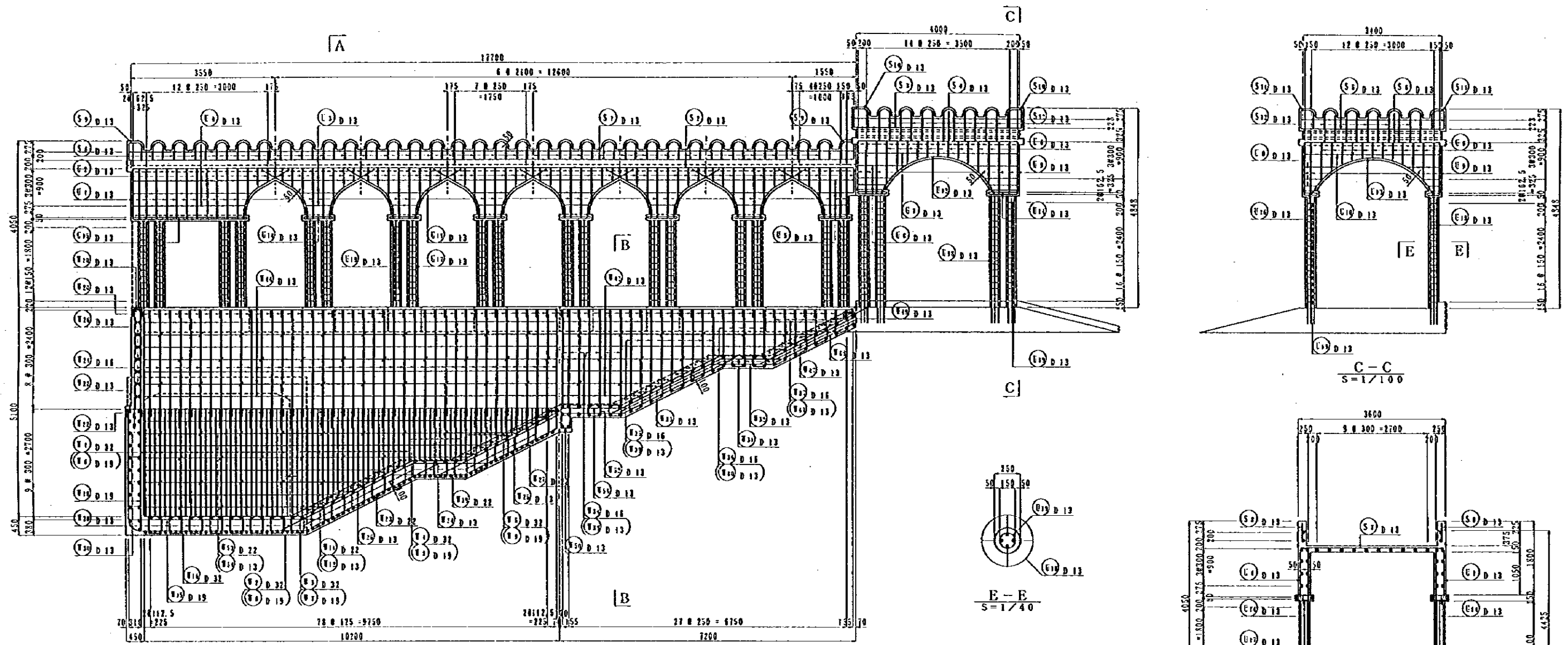

**A** SIDE VIEW  
S=1/100

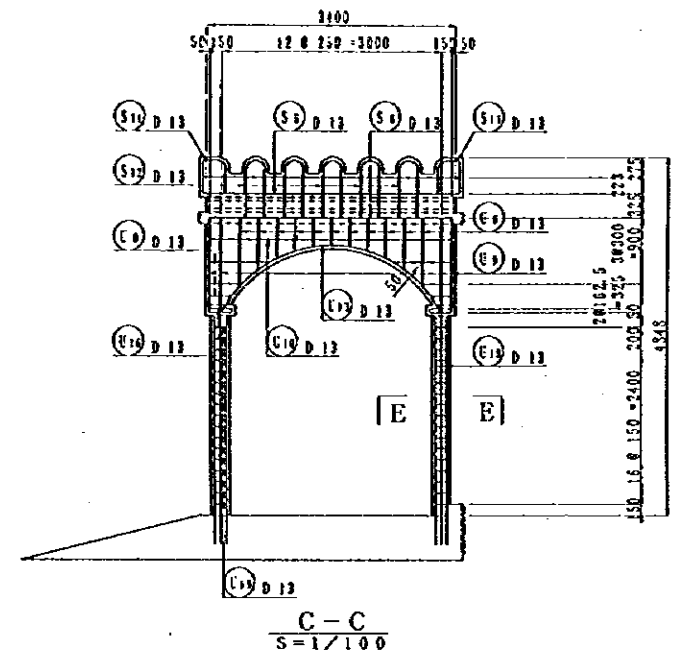

C-C  
S=1/100

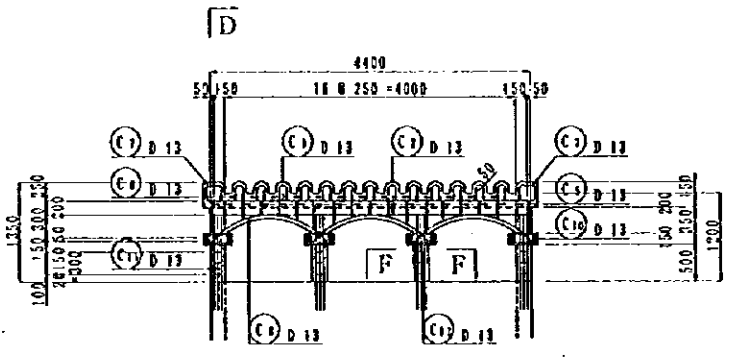

**D** CANOPY ON LIGHT  
S=1/100

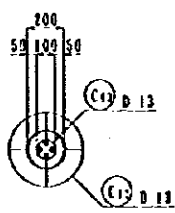

F-F  
S=1/40

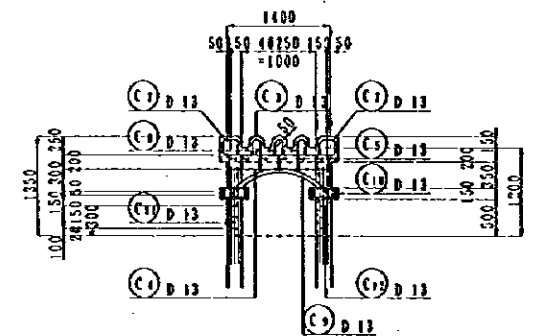

D-D  
S=1/100

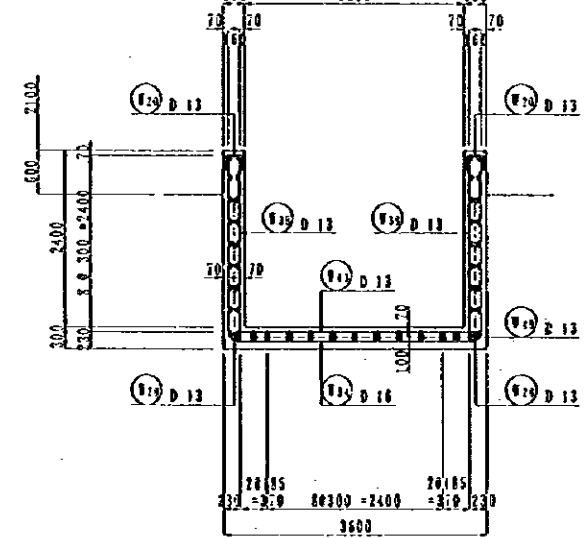

B-B  
S=1/100

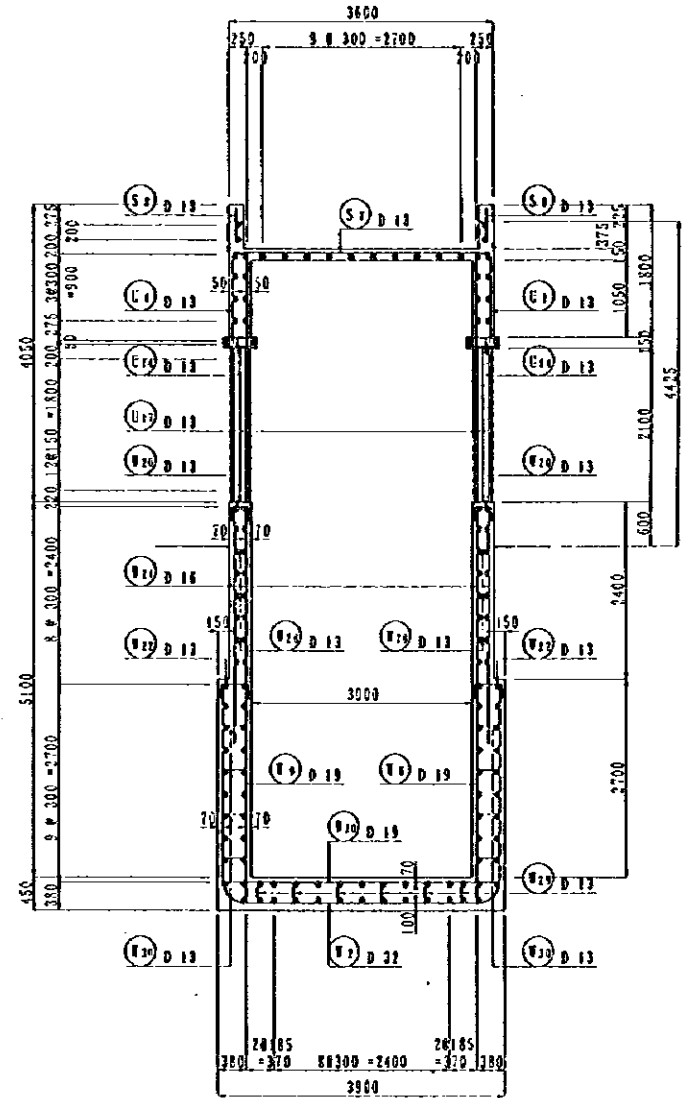

A-A  
S=1/100

NOTES:	JAPAN INTERNATIONAL COOPERATION AGENCY (JICA)	CLIENT : MINISTRY OF COMMUNICATIONS, DIRECTORATE GENERAL OF ROADS
	JICA STUDY TEAM PACIFIC CONSULTANTS INTERNATIONAL FUKUYAMA CONSULTANTS INTERNATIONAL	PROJECT : D/D ON ROAD DEVELOPMENT PROJECT ON BATINAH HIGHWAY
		TITLE : P/U-12, ASRAR BANI SA'D RE-BAR ARRANGEMENT (1)
		DATE : DVG NO. P - 4



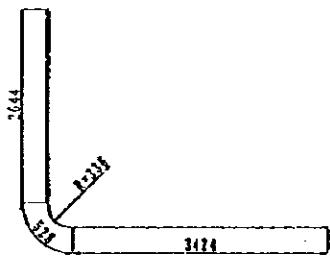

(1) 29-D32 x 6 600

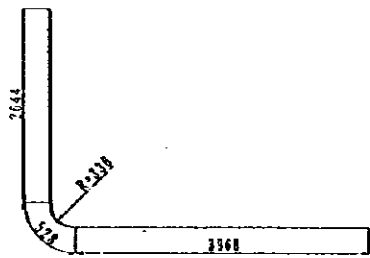

(11) 30-D32 x 7 140

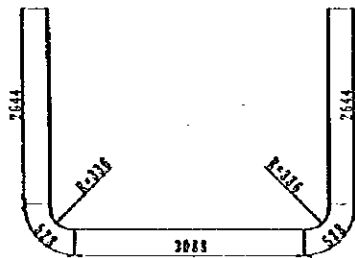
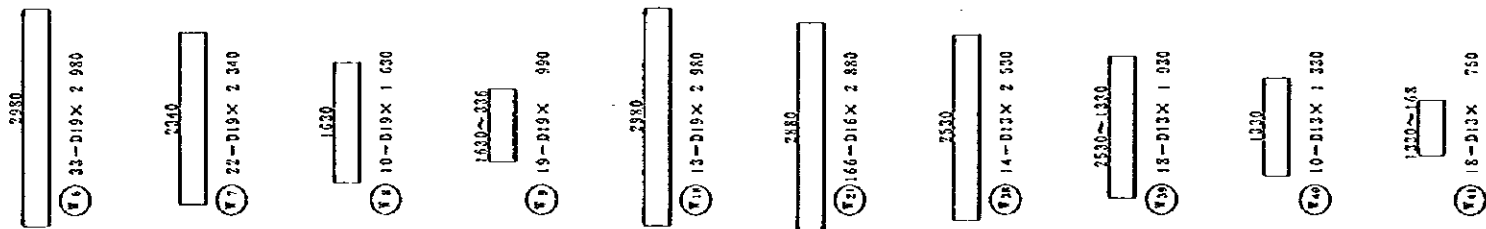

(2) 2-D32 x 9 440

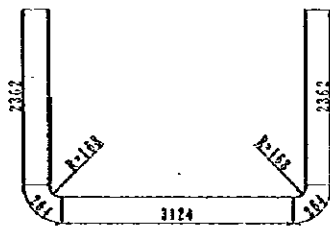

(13) 7-D16 x 8 380

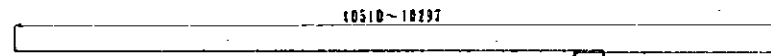

(11) 3-D22 x (10 4104 860) (160 (350))  
(12) 3-D13 x (10 4104 390)

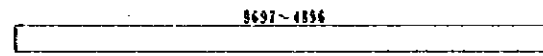

(13) 7-D22 x 7 320  
(14) 7-D13 x 7 300



(20) 155-D13 x 550

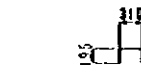

(21) 79-D13 x 360

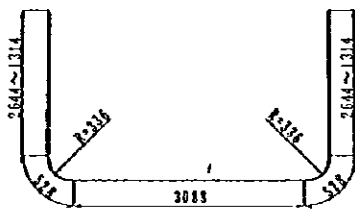

(3) 22-D32 x 8 810

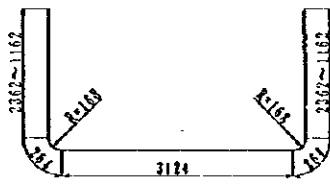

(15) 9-D16 x 7 180

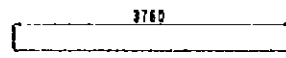

(16) 41-D19 x 3 760

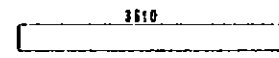

(17) 10-D22 x 3 610  
(18) 11-D13 x 3 610

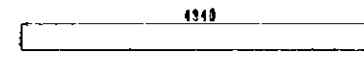

(19) 15-D19 x 4 840

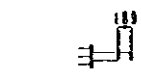

(22) 71-D13 x 420

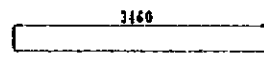

(17) 18-D13 x 3 460

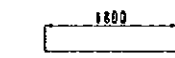

(18) 15-D13 x 1 800  
(19) 13-D22 x 1 800

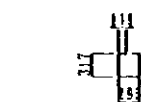

(23) 117-D13 x 1 160

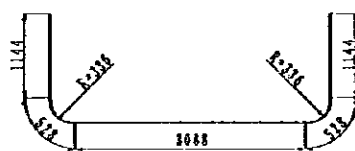

(4) 18-D32 x 6 440

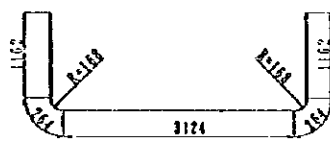

(16) 5-D16 x 5 980

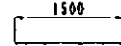

(24) 15-D13 x 1 500  
(25) 13-D13 x 1 500

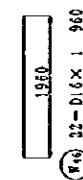
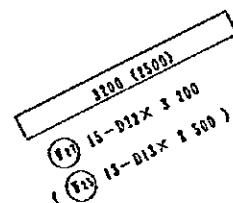
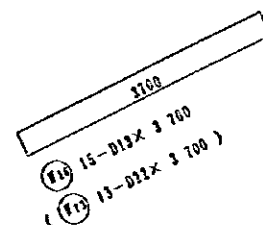

(26) 32-D13 x 1 960



(28) 68-D13 x 580

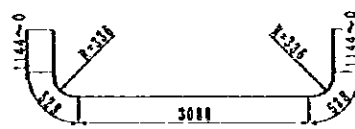

(5) 19-D32 x 5 230

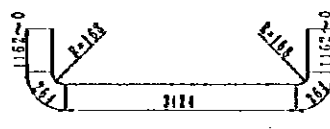

(17) 9-D16 x 4 820

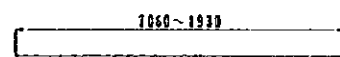

(17) 32-D13 x 4 560

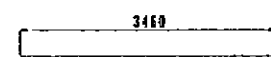

(18) 38-D13 x 3 460

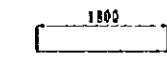

(15) 15-D13 x 1 800

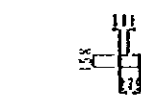

(27) 78-D13 x 820

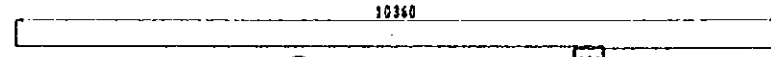

(19) 38-D13 x (10 360/390) (390)

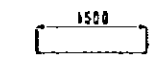

(15) 13-D13 x 1 500

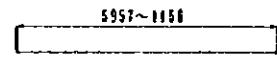

(16) 7-D12 x 3 560  
(17) 7-D13 x 3 560

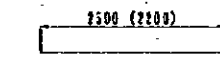

(15) 15-D13 x 2 500  
(16) 12-D13 x 2 200

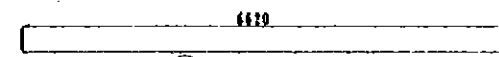

(13) 2-D13 x 6 620

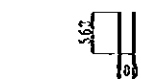

(29) 15-D13 x 1 330

NOTES:

JAPAN INTERNATIONAL COOPERATION AGENCY  
(JICA)

JICA STUDY TEAM  
PACIFIC CONSULTANTS INTERNATIONAL  
FUJIKAWA CONSULTANTS INTERNATIONAL

CLIENT : MINISTRY OF COMMUNICATIONS, DIRECTORATE GENERAL OF ROADS

PROJECT : D/D ON ROAD DEVELOPMENT PROJECT ON BATINAH HIGHWAY

TITLE : P/U-12, ASRAR BANI SA'D RE-BAR ARRANGEMENT (2)

DATE

FIG. NO. P-5



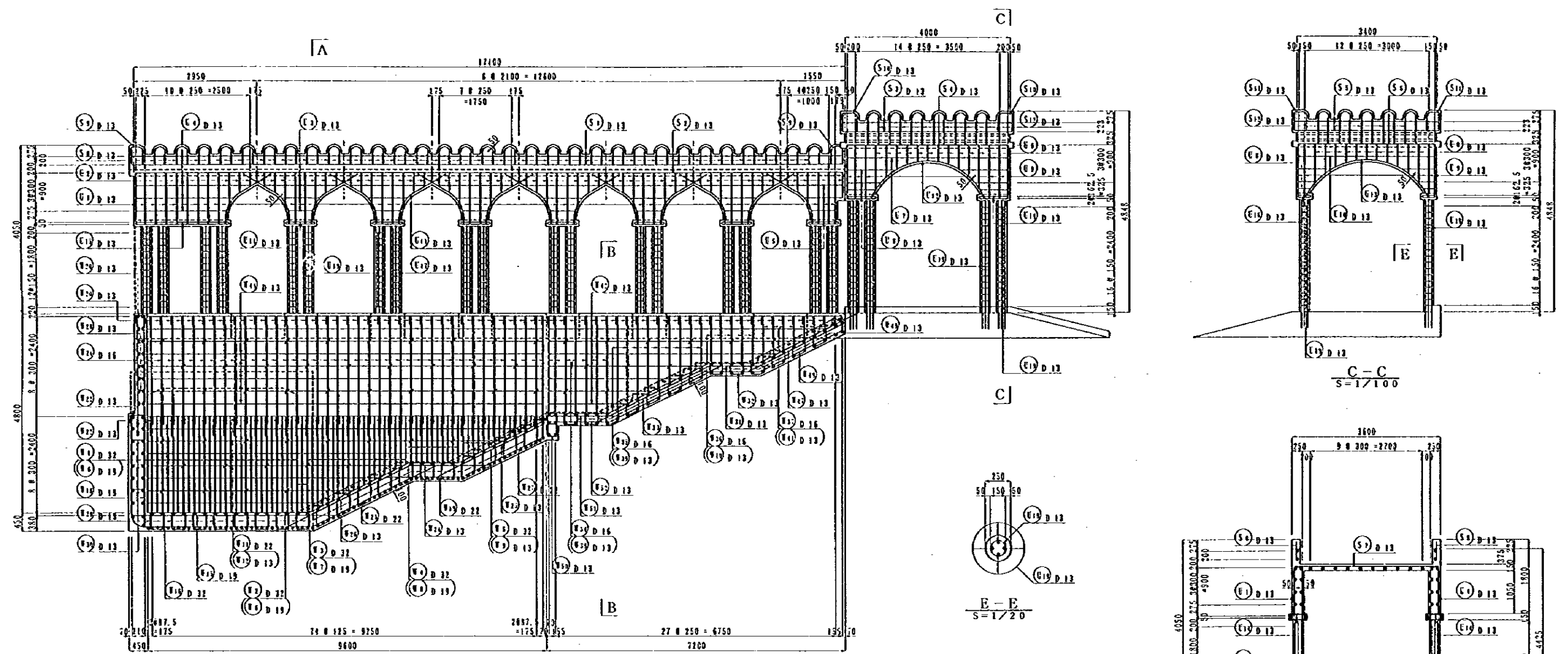

**A** SIDE VIEW  
S=1/100

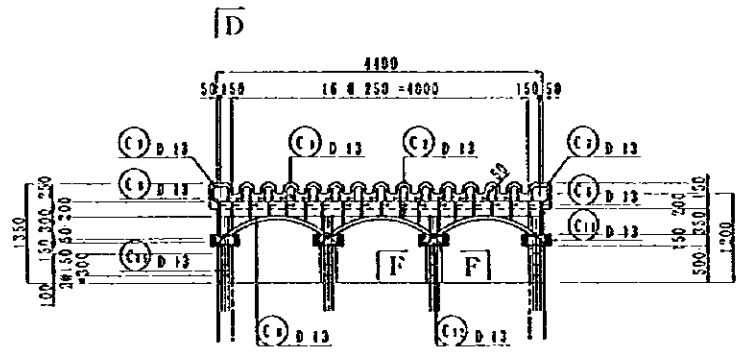

**D** CANOPY ON LIGHT  
S=1/100

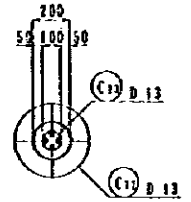

**F - F**  
S=1/40

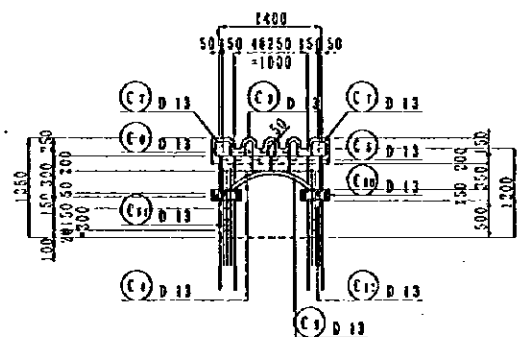

**D - D**  
S=1/100

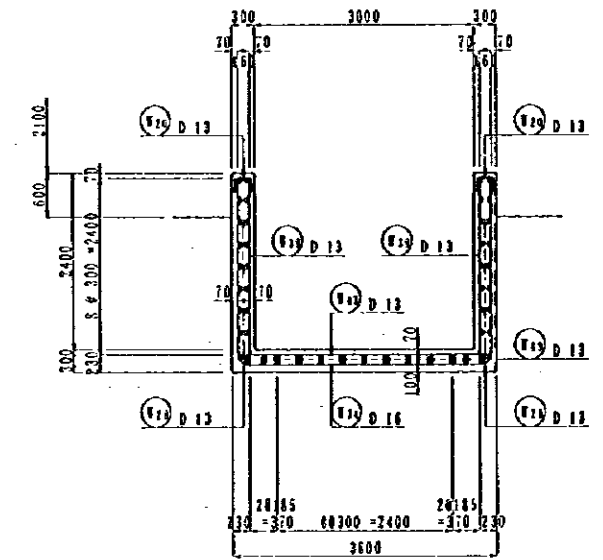

**B - B**  
S=1/100

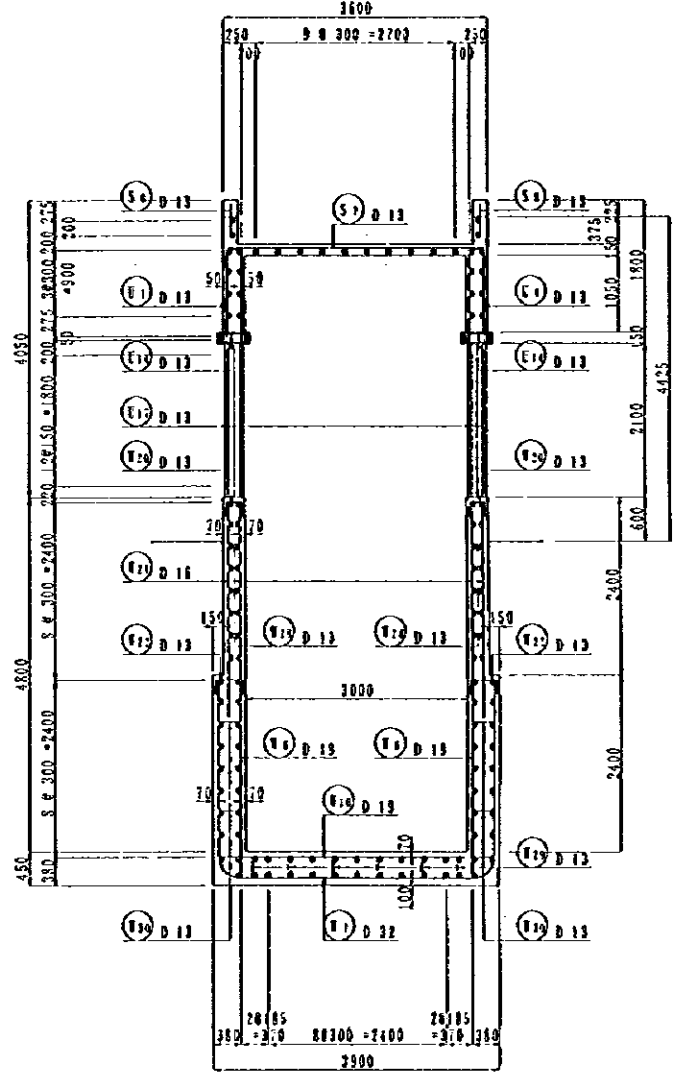

**A - A**  
S=1/100

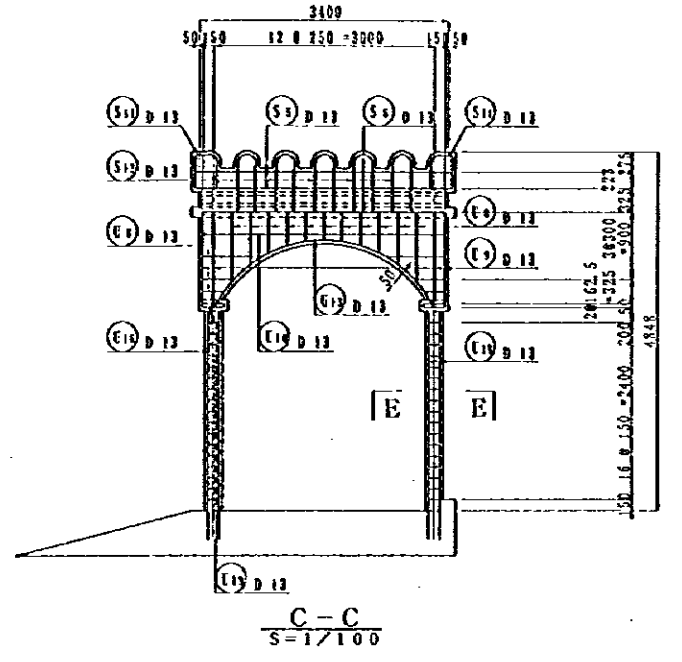

**C - C**  
S=1/100

NOTES:

JAPAN INTERNATIONAL COOPERATION AGENCY  
(JICA)  
JICA STUDY TEAM  
PACIFIC CONSULTANTS INTERNATIONAL  
FLUXVANA CONSULTANTS INTERNATIONAL

CLIENT : MINISTRY OF COMMUNICATIONS, DIRECTORATE GENERAL OF ROADS  
PROJECT : D/D ON ROAD DEVELOPMENT PROJECT ON BATINAH HIGHWAY  
TITLE : P/U-12, ASRAR BANJ SA'D RE-BAR ARRANGEMENT (4)  
DATE :  
DWG NO. P-7

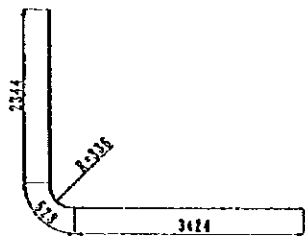

(E1) 25-D32 x 6 300

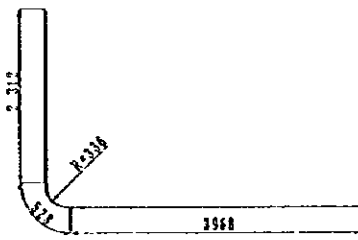

(E14) 30-D32 x 6 810

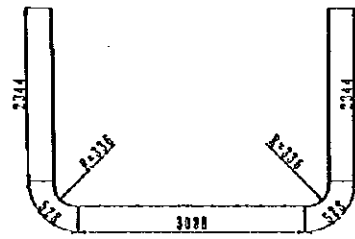

(E2) 2-D32 x 6 840

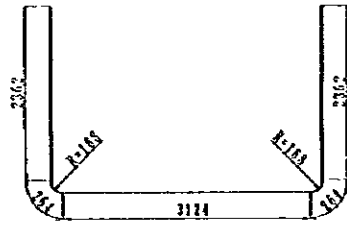

(E34) 7-D16 x 8 380

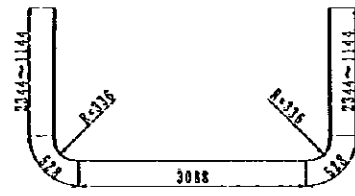

(E3) 19-D32 x 7 640

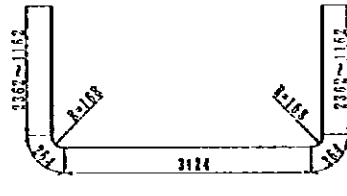

(E35) 9-D16 x 7 180

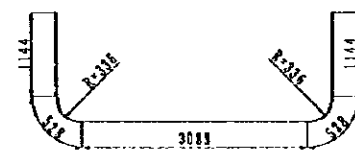

(E4) 10-D32 x 6 440

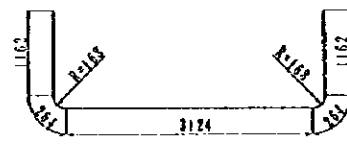

(E36) 5-D16 x 5 950

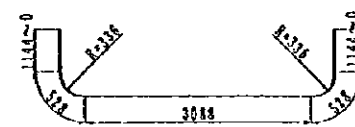

(E5) 16-D32 x 5 290

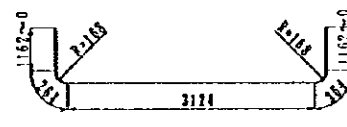

(E37) 8-D16 x 4 820

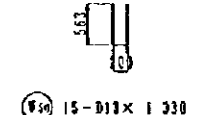
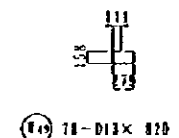
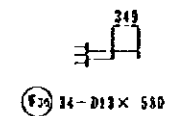
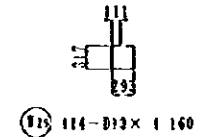
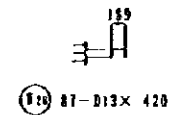
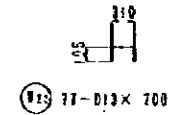
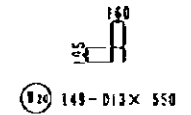
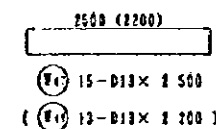
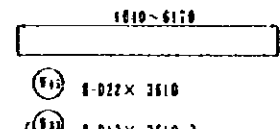
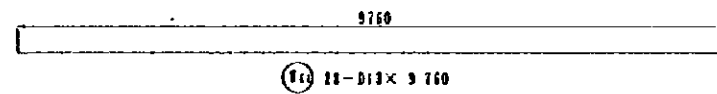
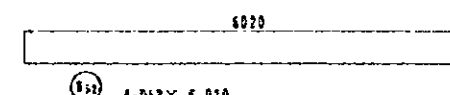
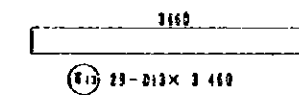
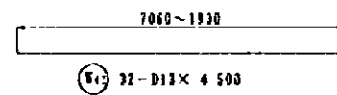
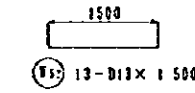
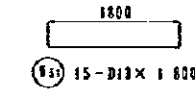
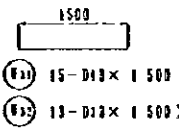
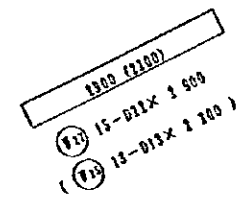
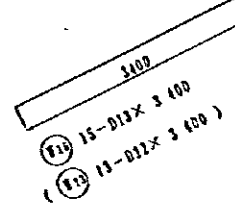
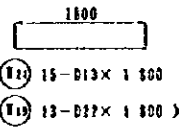
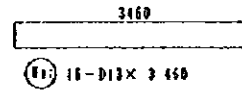
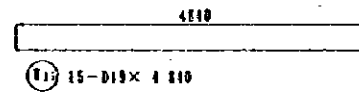
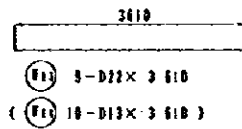
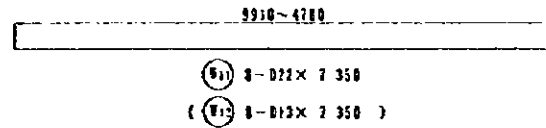
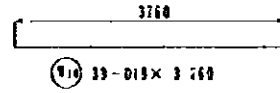
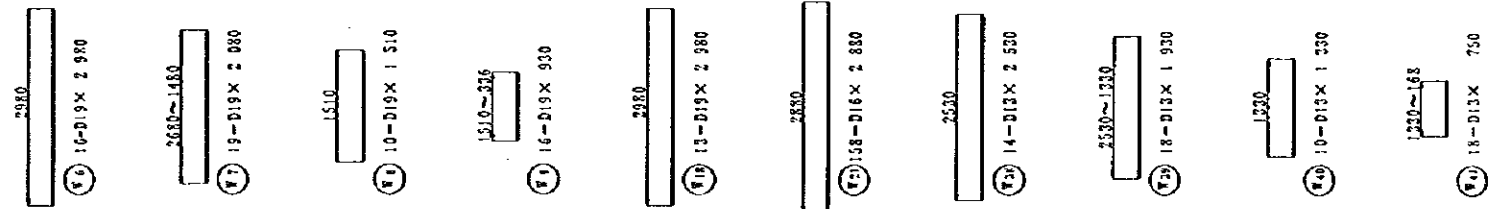

NOTES:

JAPAN INTERNATIONAL COOPERATION AGENCY (JICA)  
 JICA STUDY TEAM  
 PACIFIC CONSULTANTS INTERNATIONAL  
 PAKYANA CONSULTANTS INTERNATIONAL

CLIENT : MINISTRY OF COMMUNICATIONS, DIRECTORATE GENERAL OF ROADS  
 PROJECT : D/D ON ROAD DEVELOPMENT PROJECT ON BATINAH HIGHWAY  
 TITLE : P/U-12, ASRAR BANI SA'D RE-BAR ARRANGEMENT (5)  
 DATE : \_\_\_\_\_ DWG NO. P - 8

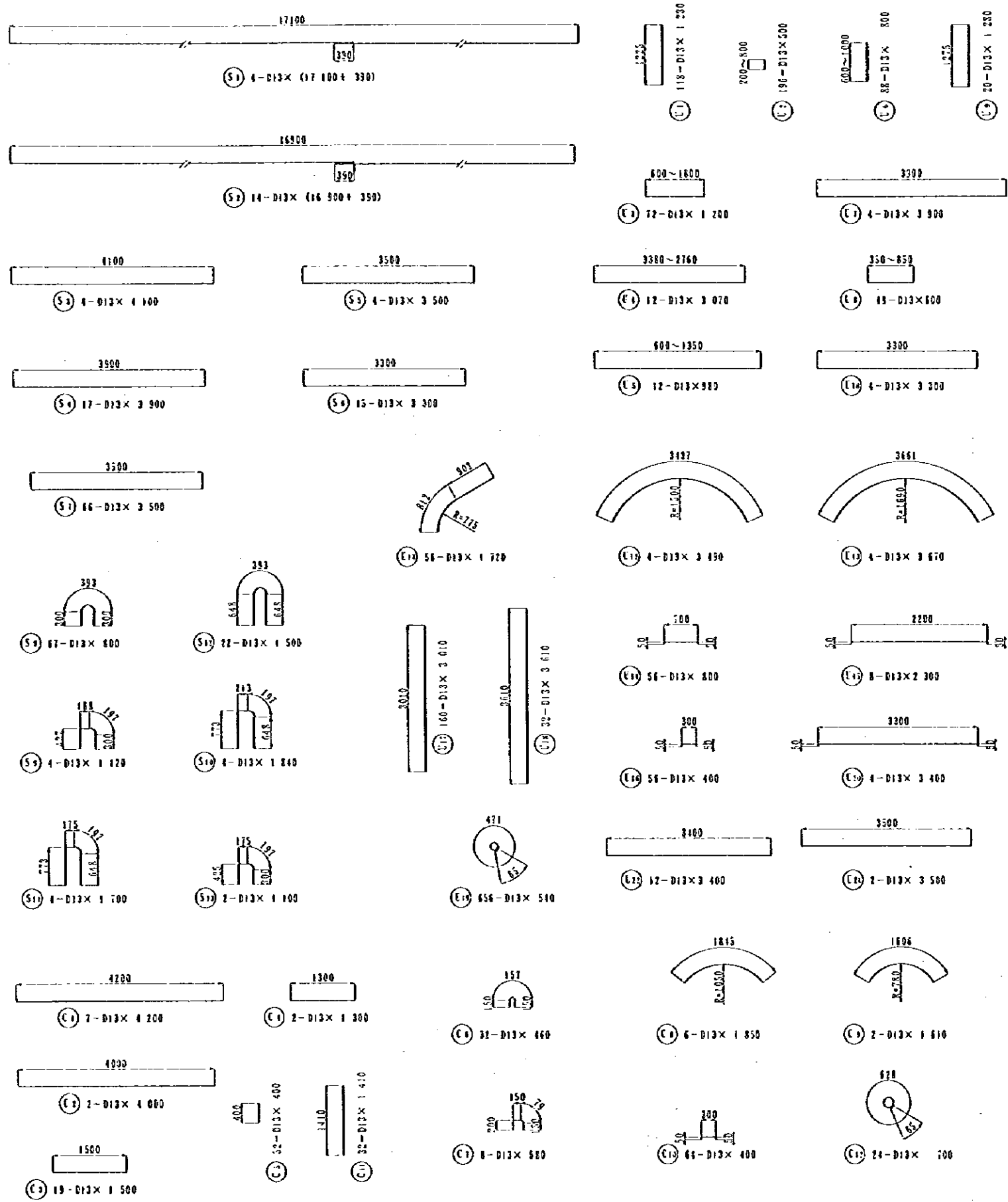

REIN. NO.	Ø (mm)	LENGTH (mm)	NOMINAL WEIGHT	NO.	C WEIGHT	WEIGHT	REMARKS
1	D 32	6 300	6.403	29	40.339	1169.8	
2	"	8 800	"	2	56.603	143.2	
3	"	7 610	"	19	48.727	925.8	
4	"	6 410	"	10	41.235	412.4	
5	"	5 290	"	16	33.872	542.0	
6	D 19	2 980	2.235	16	6.660	106.6	
7	"	2 050	"	19	4.649	88.3	
8	"	1 510	"	10	3.275	33.8	
9	"	920	"	16	2.079	33.3	
10	"	3 260	"	39	8.404	327.7	
11	D 22	2 350	3.042	8	24.359	118.9	
12	D 13	7 350	0.994	8	7.350	56.8	
13	D 22	3 610	3.042	3	10.532	98.8	
14	D 13	3 610	0.994	10	3.592	35.9	
15	D 19	4 810	2.235	15	10.817	167.3	
16	D 32	6 810	6.403	30	49.691	1308.1	
17	D 13	3 460	0.994	16	3.439	55.0	
18	D 19	2 980	2.235	13	6.660	86.6	
19	D 22	1 000	3.042	13	5.476	71.2	
20	D 13	550	0.994	149	0.517	81.5	
21	D 16	2 880	1.552	156	4.470	706.2	
22	D 13	700	0.994	77	0.694	53.6	
23	D 22	3 400	3.042	13	3.878	134.5	
24	D 13	1 890	0.994	15	4.023	60.3	
25	"	2 200	"	13	2.187	28.4	
26	"	3 400	"	15	3.383	50.7	
27	D 22	2 900	3.042	15	8.822	132.3	
28	D 13	420	0.994	39	0.418	37.2	
29	"	1 160	"	114	1.153	131.4	
30	"	580	"	34	0.577	19.6	
31	"	1 500	"	15	1.491	22.4	
32	"	1 500	"	13	1.491	19.4	
33	"	3 610	"	8	3.588	28.7	
34	D 16	8 350	1.552	7	13.026	91.0	
35	"	7 180	"	9	11.143	100.3	
36	"	5 980	"	5	9.281	46.4	
37	"	4 820	"	9	7.481	67.3	
38	D 13	2 530	0.994	14	2.515	35.2	
39	"	1 930	"	18	1.918	34.5	
40	"	1 330	"	19	1.322	13.2	
41	"	750	"	18	0.746	13.4	
42	"	4 500	"	32	4.473	143.1	
43	"	3 480	"	29	3.439	99.7	
44	"	9 760	"	28	9.751	271.6	
45	D 22	3 610	3.042	8	10.982	87.9	
46	D 16	1 660	1.552	32	2.576	82.4	
47	D 13	2 500	0.994	15	2.485	27.3	
48	"	2 200	"	13	2.187	28.4	
49	"	820	"	78	0.815	63.6	
50	"	1 330	"	19	1.322	19.8	
51	"	1 800	"	15	1.789	26.8	
52	"	1 500	"	13	1.491	19.4	
						2 256.4	

REIN. NO.	Ø (mm)	LENGTH (mm)	NOMINAL WEIGHT	NO.	C WEIGHT	WEIGHT	REMARKS
S 1	D 13	17 450	0.994	4	17.355	69.9	
2	"	17 250	"	11	17.186	240.6	
3	"	4 100	"	4	4.075	16.3	
4	"	3 900	"	17	3.872	65.8	
5	"	3 500	"	4	3.478	13.9	
6	"	3 300	"	15	3.280	49.2	
7	"	3 500	"	68	3.478	236.4	
8	"	800	"	17	0.785	59.3	
9	"	1 120	"	4	1.113	4.5	
10	"	1 840	"	4	1.829	7.3	
11	"	1 700	"	4	1.690	6.8	
12	"	1 500	"	22	1.491	32.8	
13	"	1 100	"	2	1.093	2.2	
						751.9	

REIN. NO.	Ø (mm)	LENGTH (mm)	NOMINAL WEIGHT	NO.	C WEIGHT	WEIGHT	REMARKS
E 1	D 13	1 730	0.994	118	1.223	144.3	
2	"	500	"	156	0.497	97.4	
3	"	1 260	"	72	1.193	85.9	
4	"	3 070	"	12	3.052	36.6	
5	"	980	"	12	0.974	11.7	
6	"	800	"	89	0.795	70.0	
7	"	3 900	"	4	3.872	15.5	
8	"	600	"	34	0.596	20.3	
9	"	1 280	"	20	1.272	25.4	
10	"	3 300	"	4	3.280	13.1	
11	"	1 720	"	56	1.710	95.7	
12	"	3 490	"	4	3.469	13.9	
13	"	3 670	"	4	3.648	14.6	
14	"	800	"	56	0.795	44.5	
15	"	2 300	"	8	2.288	18.3	
16	"	400	"	56	0.398	22.3	
17	"	3 610	"	160	2.592	418.7	
18	"	3 610	"	37	3.588	114.3	
19	"	540	"	656	0.532	352.1	
20	"	3 400	"	4	3.380	13.5	
21	"	3 500	"	2	3.478	7.0	
22	"	3 400	"	12	3.360	40.6	
						1 736.2	

REIN. NO.	Ø (mm)	LENGTH (mm)	NOMINAL WEIGHT	NO.	C WEIGHT	WEIGHT	REMARKS
C 1	D 13	4 200	0.994	7	4.375	29.7	
2	"	4 000	"	2	3.976	8.0	
3	"	1 500	"	19	1.491	28.3	
4	"	1 300	"	2	1.292	2.6	
5	"	400	"	52	0.398	20.7	
6	"	460	"	32	0.457	14.6	
7	"	580	"	8	0.577	4.6	
8	"	1 850	"	6	1.839	11.0	
9	"	1 610	"	8	1.600	3.2	
10	"	400	"	64	0.398	25.4	
11	"	1 410	"	32	1.402	44.9	
12	"	700	"	24	0.696	16.7	
						209.1	

D 32	4 471.3
D 22	793.6
D 19	838.6
D 16	1 093.6
D 13	4 197.6
TOTAL WEIGHT 11 259.7	

NOTES:

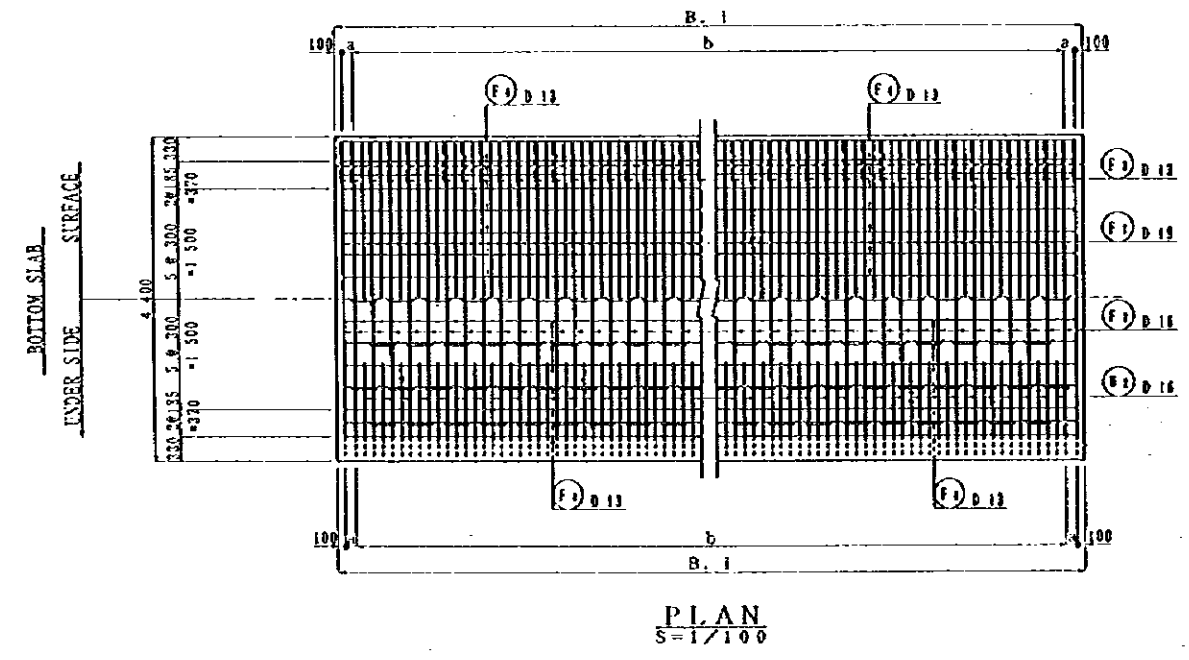
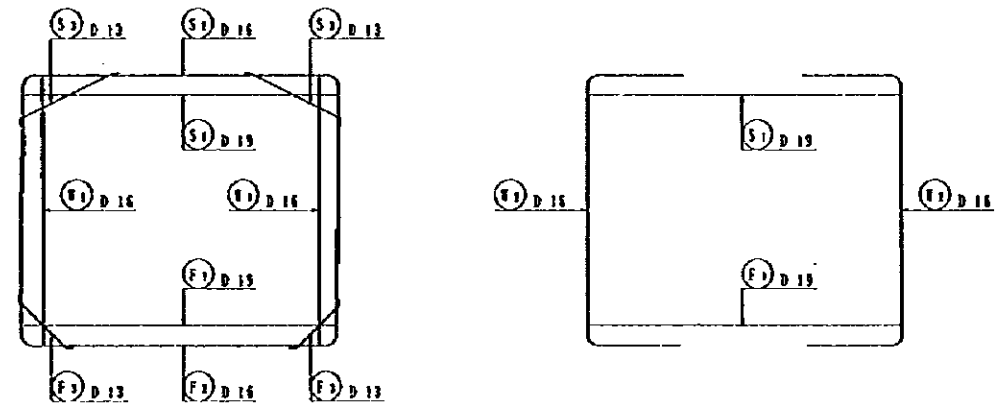
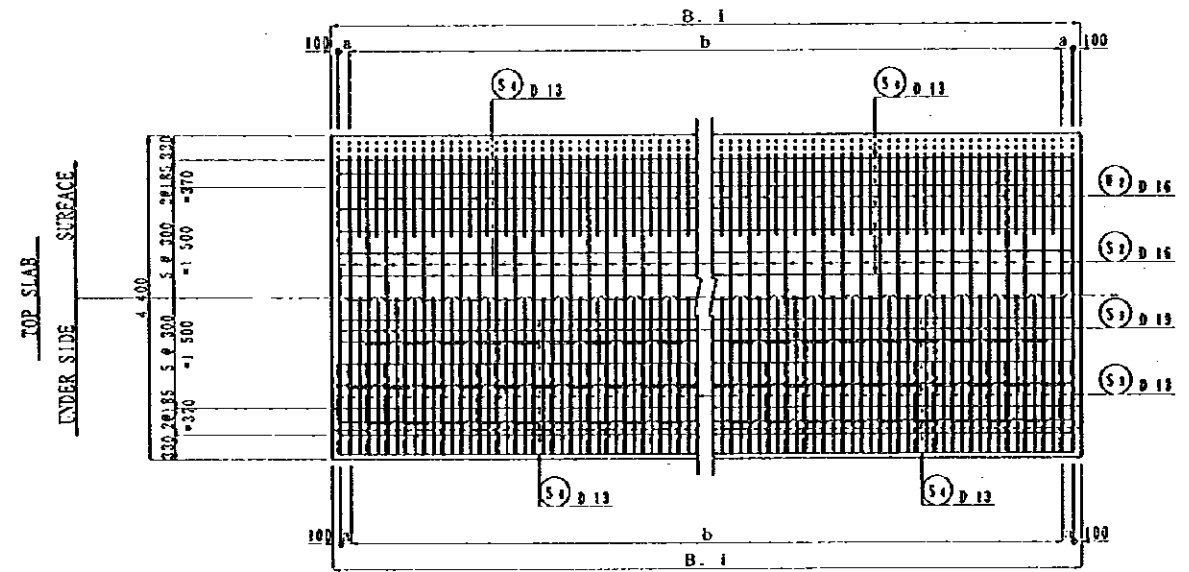
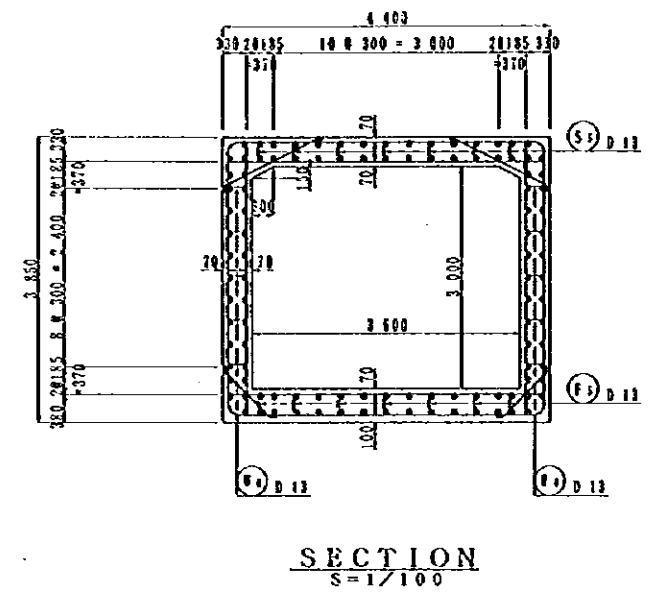
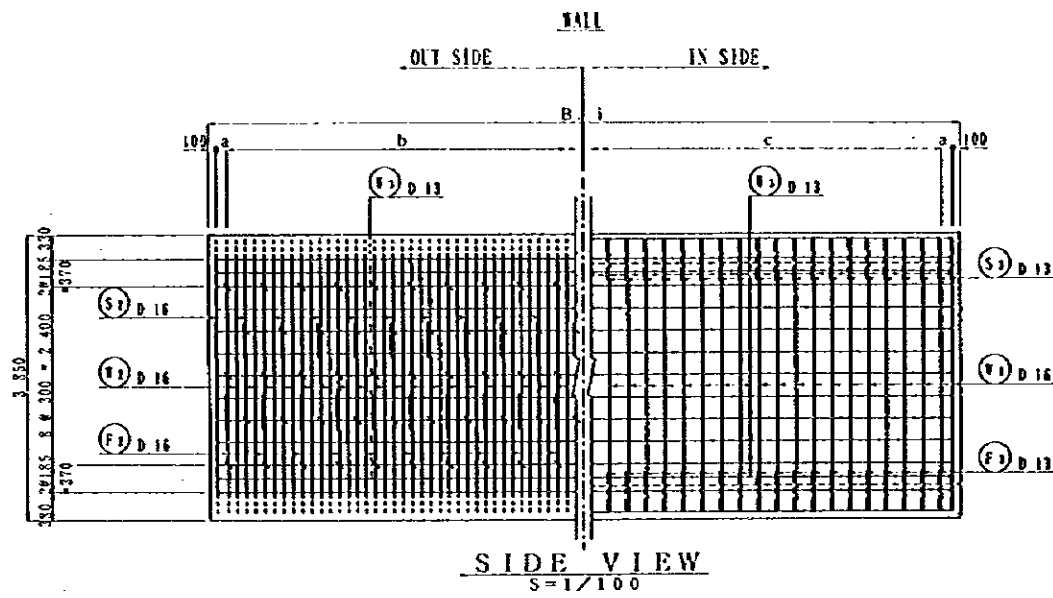

	B. I	a	b	c
TYPE A	15 000	150	116 @ 125	58 @ 250
TYPE C	4 450	—	34 @ 125	17 @ 250
TYPE D	8 450	—	66 @ 125	33 @ 250

NOTES:

JAPAN INTERNATIONAL COOPERATION AGENCY  
(JICA)  
JICA STUDY TEAM  
PACIFIC CONSULTANTS INTERNATIONAL  
ELUYAMA CONSULTANTS INTERNATIONAL

CLIENT : MINISTRY OF COMMUNICATIONS, DIRECTORATE GENERAL OF ROADS  
PROJECT : D/D ON ROAD DEVELOPMENT PROJECT ON BATINAH HIGHWAY  
TITLE : P/U-12, ASRAR BANI SA'D RE-BAR ARRANGEMENT (7)  
DATE : \_\_\_\_\_  
DWG NO. P-10

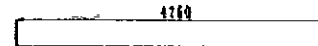
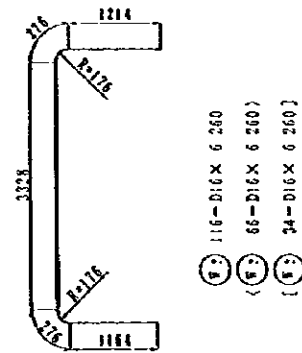
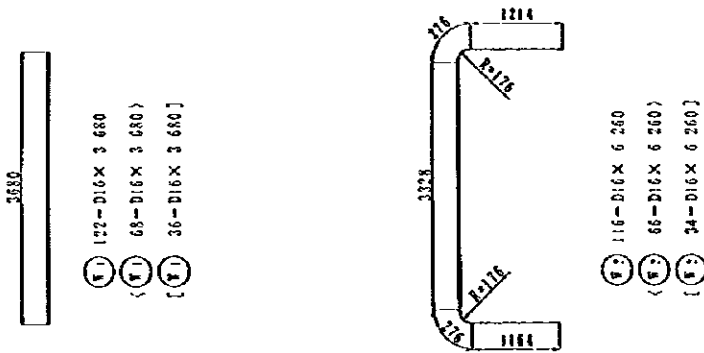

- (S) 119-D19 x 4 260
- (S) 67-D19 x 4 260
- (S) 35-D19 x 4 260

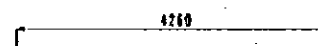

- (F) 119-D19 x 4 260
- (F) 67-D19 x 4 260
- (F) 35-D19 x 4 260

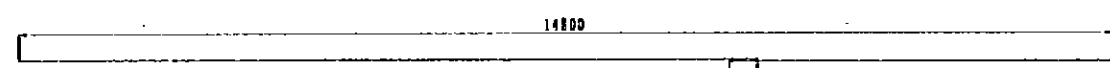

- (S) 32-D13 x (14 800 + 390)
- (F) 44-D13 x (14 800 + 390)
- (F) 32-D13 x (14 800 + 390)

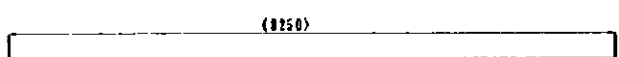

- (S) 32-D13 x 8 250
- (F) 44-D13 x 8 250
- (F) 32-D13 x 8 250

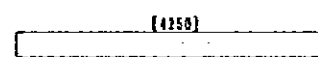

- (S) 32-D13 x 4 250
- (F) 44-D13 x 4 250
- (F) 32-D13 x 4 250

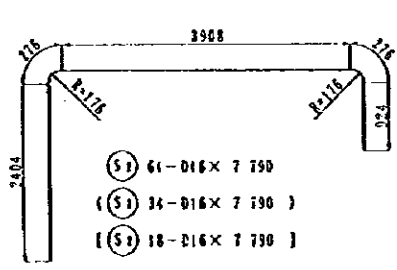

- (S) 61-D16 x 7 750
- (S) 34-D16 x 7 750
- (S) 18-D16 x 7 750

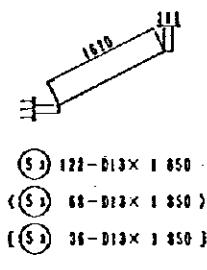

- (S) 122-D13 x 1 850
- (S) 68-D13 x 1 850
- (S) 36-D13 x 1 850

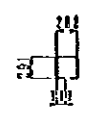

- (S) 200-D13 x 1 050
- (S) 114-D13 x 1 050
- (S) 58-D13 x 1 050

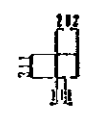

- (F) 200-D13 x 1 120
- (F) 114-D13 x 1 120
- (F) 58-D13 x 1 120

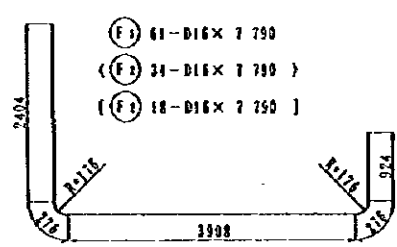

- (F) 61-D16 x 7 750
- (F) 34-D16 x 7 750
- (F) 18-D16 x 7 750

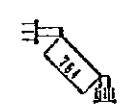

- (F) 122-D13 x 950
- (F) 68-D13 x 950
- (F) 36-D13 x 950

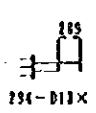

- (F) 294-D13 x 520
- (F) 164-D13 x 520
- (F) 84-D13 x 520

REIS NO.	Ø (mm)	LENGTH (mm)	NOVINAL WEIGHT	SLNO	C WEIGHT	WEIGHT	REMARKS
<b>TYPE-A</b>							
S 1	D 19	4 260	2.235	119	9.521	1133.0	
2	D 16	7 750	1.552	61	12.050	737.5	
3	D 13	1 850	0.994	122	1.833	224.4	
4	"	15 190	"	32	15.039	483.2	
5	"	1 050	"	202	1.083	219.9	
F 1	D 16	3 650	1.552	122	5.711	696.7	
2	"	6 260	"	116	9.716	1127.1	
3	D 13	15 190	0.994	44	15.039	664.4	
4	"	520	"	294	0.517	152.0	
F 1	D 19	4 260	2.235	119	9.521	1133.0	
2	D 16	7 750	1.552	61	12.050	737.5	
3	D 13	990	0.994	122	0.994	120.0	
4	"	15 190	"	32	15.039	483.2	
5	"	1 130	"	203	1.123	228.0	
8139.9							
<b>TYPE-C</b>							
S 1	D 19	4 260	2.235	67	9.521	637.9	
2	D 16	7 750	1.552	34	12.050	411.1	
3	D 13	1 850	0.994	68	1.833	125.1	
4	"	8 250	"	32	8.201	267.4	
5	"	1 050	"	114	1.083	123.5	
F 1	D 16	3 650	1.552	68	5.711	358.3	
2	"	6 260	"	66	9.716	631.3	
3	D 13	8 250	0.994	44	8.201	360.8	
4	"	520	"	164	0.517	84.8	
F 1	D 19	4 260	2.235	67	9.521	637.9	
2	D 16	7 750	1.552	34	12.050	411.1	
3	D 13	990	0.994	68	0.994	66.9	
4	"	8 250	"	32	8.201	267.4	
5	"	1 130	"	114	1.123	128.0	
4541.5							
<b>TYPE-D</b>							
S 1	D 19	4 260	2.235	35	9.521	333.2	
2	D 16	7 750	1.552	18	12.050	217.6	
3	D 13	1 050	0.994	36	1.833	66.2	
4	"	4 250	"	32	4.275	135.2	
5	"	1 050	"	58	1.083	67.8	
F 1	D 16	3 640	1.552	34	5.711	205.6	
2	"	6 260	"	34	9.716	330.9	
3	D 13	4 250	0.994	44	4.275	182.3	
4	"	520	"	84	0.517	43.4	
F 1	D 19	4 260	2.235	35	9.521	333.2	
2	D 16	7 750	1.552	18	12.050	217.6	
3	D 13	990	0.994	36	0.994	35.4	
4	"	4 250	"	32	4.275	135.2	
5	"	1 130	"	58	1.123	65.1	
2368.7							
D 19 4208.2							
D 16 6121.7							
D 13 4718.2							
TOTAL WEIGHT 15048.1							

NOTES: ( ) TYPE-C  
[ ] TYPE-D

JAPAN INTERNATIONAL COOPERATION AGENCY (JICA)  
JICA STUDY TEAM  
PACIFIC CONSULTANTS INTERNATIONAL  
FLUYAMA CONSULTANTS INTERNATIONAL

CLIENT : MINISTRY OF COMMUNICATIONS, DIRECTORATE GENERAL OF ROADS  
PROJECT : D/D ON ROAD DEVELOPMENT PROJECT ON BATINAH HIGHWAY  
TITLE : P/U-12, ASRAR BANI SA'D RE-BAR ARRANGEMENT (8)  
DATE :  
DWG NO. P-11





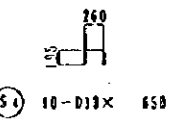
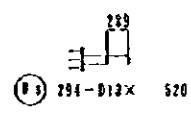
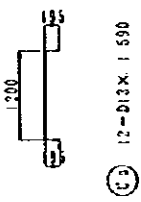
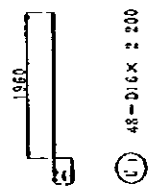
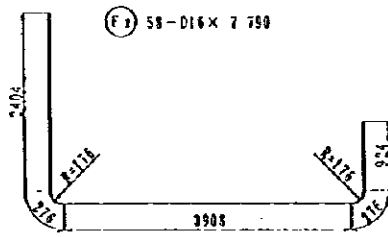
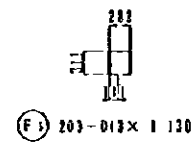
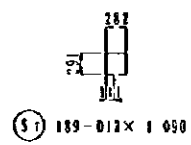
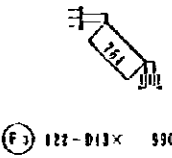
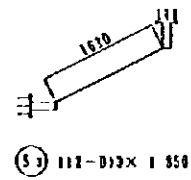
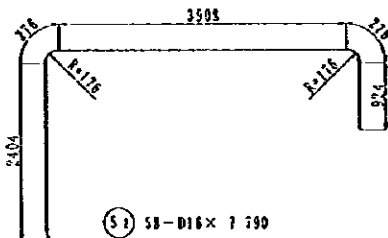
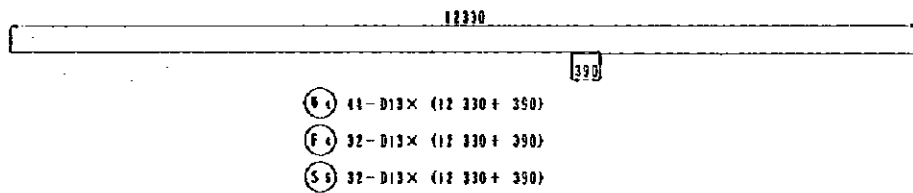
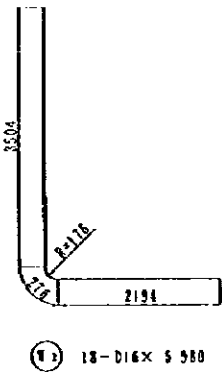
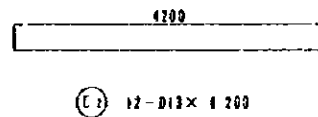
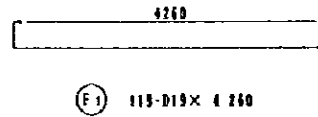
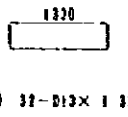
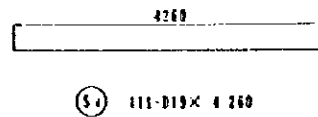
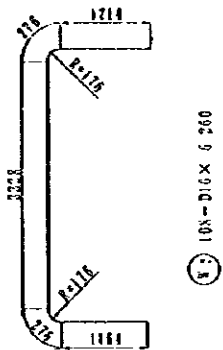
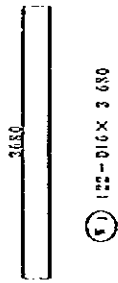

REF. NO.	Ø (mm)	LENGTH (mm)	NOMINAL WEIGHT	SLWB	C WEIGHT	WEIGHT	REMARKS
<b>TYPE-B</b>							
S 1	D 13	4 260	2.235	111	9.585	1056.8	—
2	D 16	7 790	1.552	58	12.052	701.2	—
3	D 13	1 850	0.934	112	1.841	206.2	—
4	"	850	"	10	0.648	6.5	—
5	"	12 720	"	32	12.648	404.8	—
6	"	1 330	"	32	1.322	42.3	—
7	"	1 090	"	189	1.083	204.7	—
<b>TYPE-C</b>							
W 1	D 16	3 630	1.552	122	5.711	686.2	—
2	"	6 240	"	108	9.746	1049.3	—
3	"	5 930	"	18	9.281	167.1	—
4	D 13	12 720	0.934	44	12.648	556.3	—
5	"	520	"	234	0.517	152.0	—
<b>TYPE-D</b>							
F 1	D 13	4 260	2.235	113	9.521	1132.0	—
2	D 16	7 790	1.552	58	12.050	701.2	—
3	D 13	390	0.934	122	0.934	120.0	—
4	"	12 720	"	32	12.641	404.6	—
5	"	1 130	"	203	1.123	228.0	—
<b>TYPE-E</b>							
U 1	D 16	2 200	1.552	48	3.414	183.9	—
2	D 13	4 200	0.934	12	4.175	50.1	—
3	"	1 590	"	12	1.580	19.0	—
					D 19	2189.8	
					D 16	3479.4	
					D 13	2394.1	
					<b>TOTAL WEIGHT</b>	<b>8063.3</b>	

NOTES:

JAPAN INTERNATIONAL COOPERATION AGENCY (JICA)  
 JICA STUDY TEAM  
 PACIFIC CONSULTANTS INTERNATIONAL  
 FUKUYAMA CONSULTANTS INTERNATIONAL

CLIENT : MINISTRY OF COMMUNICATIONS, DIRECTORATE GENERAL OF ROADS  
 PROJECT : D/D ON ROAD DEVELOPMENT PROJECT ON BATINAH HIGHWAY  
 TITLE : P/U-12, ASRAR BANI SA'D RE-BAR ARRANGEMENT (10)  
 DATE : \_\_\_\_\_ DWG NO. P-13

FIRST CONSTRUCTION STAGE

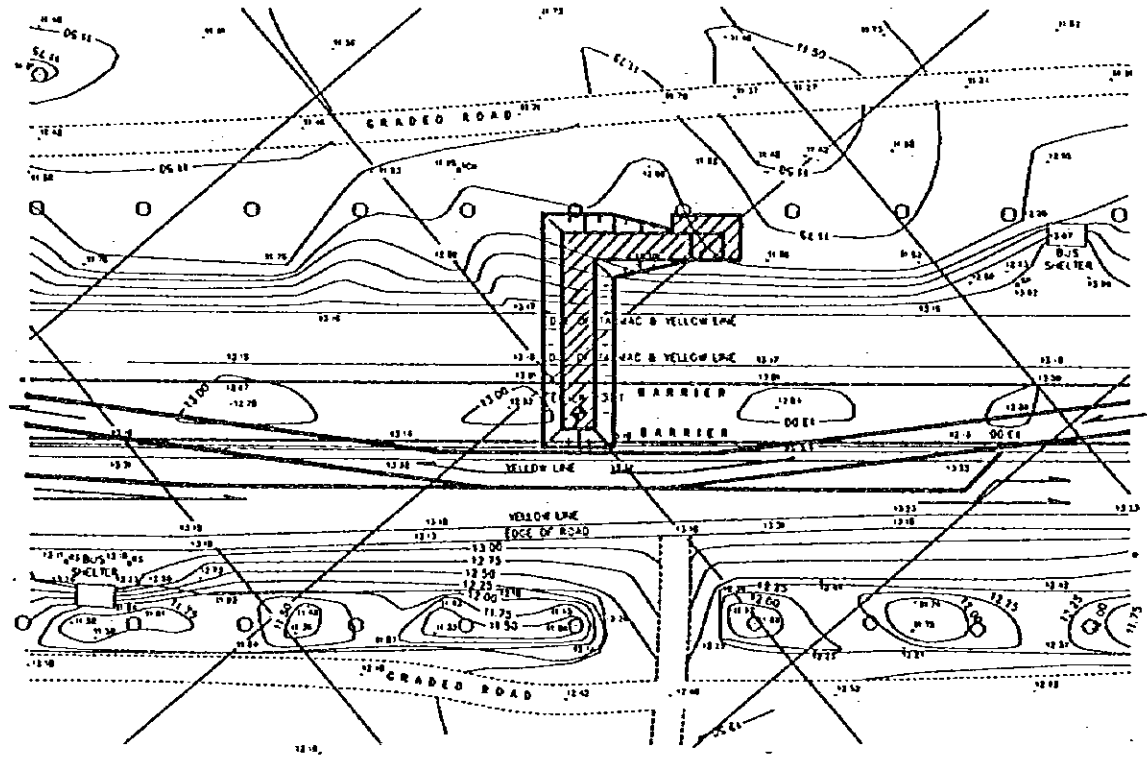

SECOND CONSTRUCTION STAGE

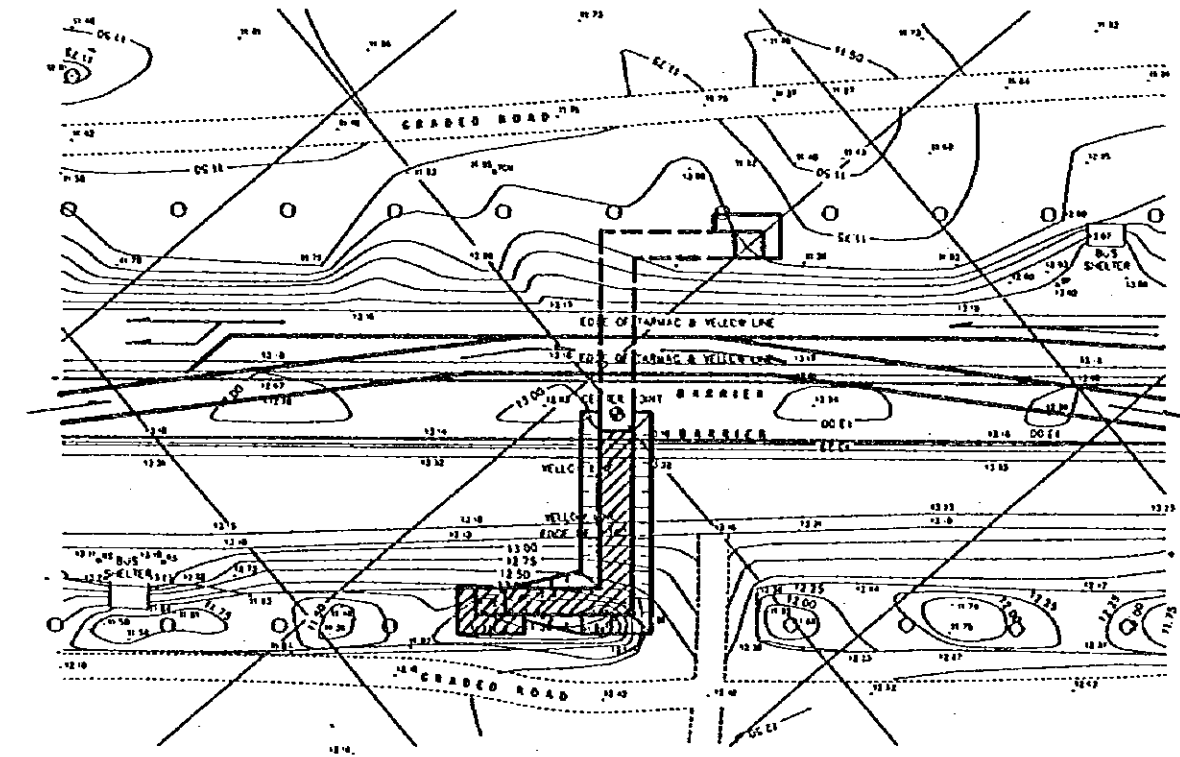

THIRD CONSTRUCTION STAGE

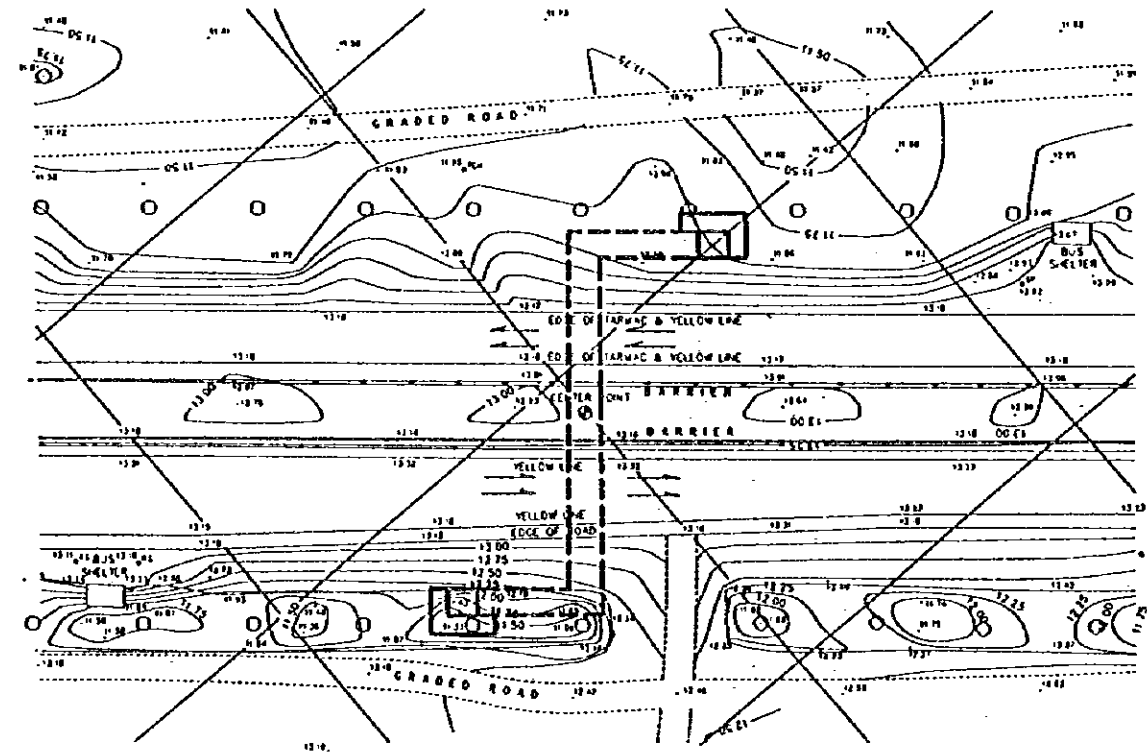

FIRST CONSTRUCTION STAGE

1. Divert traffic from the existing carriageway and demarcate the yard for the first stage of construction.
2. Carry out the first stage of construction for the underpass.
3. After completion of first stage of construction, restore the existing carriageway to allow traffic flow.

SECOND CONSTRUCTION STAGE

1. Divert traffic from the other carriageway and demarcate the yard for the second stage of construction.
2. Carry out the second stage of construction for the underpass.
3. After completion of second stage of construction, restore the existing carriageway to allow traffic flow.

THIRD CONSTRUCTION STAGE

1. Carry out accessory installation work for pedestrian underpass and open it to use.
2. Construction completed.

NOTES:

JAPAN INTERNATIONAL COOPERATION AGENCY  
(JICA)  
JICA STUDY TEAM  
PACIFIC CONSULTANTS INTERNATIONAL  
FUKUYAMA CONSULTANTS INTERNATIONAL

CLIENT: MINISTRY OF COMMUNICATIONS, DIRECTORATE GENERAL OF ROADS  
PROJECT: D/D ON ROAD DEVELOPMENT PROJECT ON BATINAH HIGHWAY  
TITLE: SEQUENCE OF ASRAR DANI SA'O PAU CONSTRUCTION  
DATE: \_\_\_\_\_ DWGNO. T-1

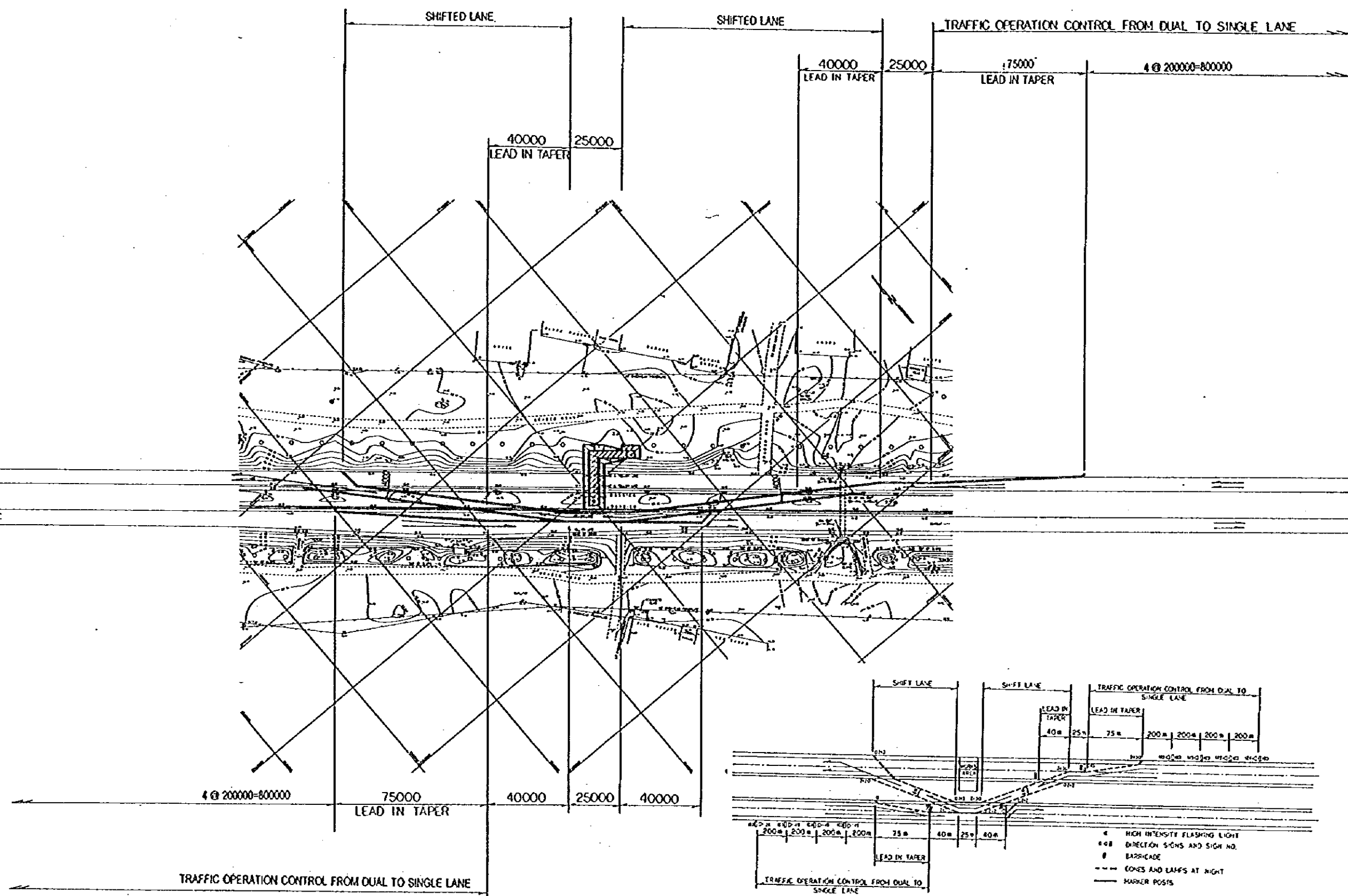

SCALE 1/2000

GENERAL LAYOUT PLAN OF P/U WORKS

NOTES:

JAPAN INTERNATIONAL COOPERATION AGENCY  
(JICA)  
JICA STUDY TEAM  
PACIFIC CONSULTANTS INTERNATIONAL  
FUKUYAMA CONSULTANTS INTERNATIONAL

CLIENT: MINISTRY OF COMMUNICATIONS, DIRECTORATE GENERAL OF ROADS  
PROJECT: D/D ON ROAD DEVELOPMENT PROJECT ON BATINAH HIGHWAY  
TITLE: DETOUR LAYOUT OF ASRAR BANI SA'D P/U WORKS  
DATE: \_\_\_\_\_ DWGNO. T-2



