

**SULTANATE OF OMAN**  
**MINISTRY OF COMMUNICATIONS**  
**DIRECTORATE GENERAL OF ROADS**

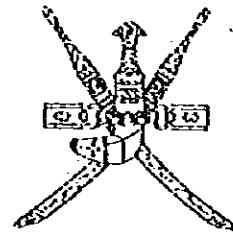

**CONSTRUCTION OF PEDESTRIAN UNDERPASS**  
**AT**  
**AL KHADRA**  
**BATINAH HIGHWAY**

**TENDER DOCUMENT**

**DRAWINGS**

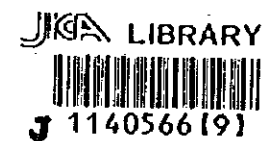

**PACIFIC CONSULTANTS INTERNATIONAL**  
**FUKUYAMA CONSULTANTS INTERNATIONAL**

March, 1997

SSF
CR(5)
97-015

**DRAWING SCHEDULE**  
**(PU7-AL KHADRA PEDESTRIAN UNDERPASS)**

SHEET NO.	DRAWING TITLE
<b>G</b>	<b>GENERAL</b>
G - 1	Drawing Schedule
<b>P</b>	<b>PEDESTRIAN UNDERPASS</b>
P - 1	General View (1)
P - 2	General View (2)
P - 3	General View (3)
P - 4	Re-bar Arrangement (1)
P - 5	Re-bar Arrangement (2)
P - 6	Re-bar Arrangement (3)
P - 7	Re-bar Arrangement (4)
P - 8	Re-bar Arrangement (5)
P - 9	Re-bar Arrangement (6)
P - 10	Re-bar Arrangement (7)
<b>T</b>	<b>TEMPORARY WORKS</b>
T - 1	Construction Sequence
T - 2	Detour Layout

<b>NOTES:</b>		JAPAN INTERNATIONAL COOPERATION AGENCY (JICA)	CLIENT : MINISTRY OF COMMUNICATIONS, DIRECTORATE GENERAL OF ROADS
		JICA STUDY TEAM	PROJECT : D/D ON ROAD DEVELOPMENT PROJECT ON BATINAH HIGHWAY
		PACIFIC CONSULTANTS INTERNATIONAL FUKUYAMA CONSULTANTS INTERNATIONAL	TITLE : PU-7, AL KHADRA DRAWING SCHEDULE
			DATE

1140566(9)

(1) ...  
(2) ...  
(3) ...  
(4) ...  
(5) ...

...

...

...

...

...

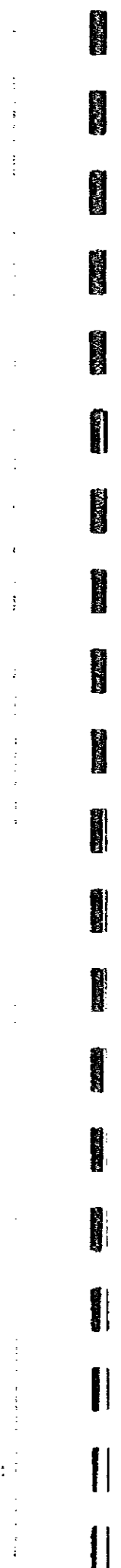

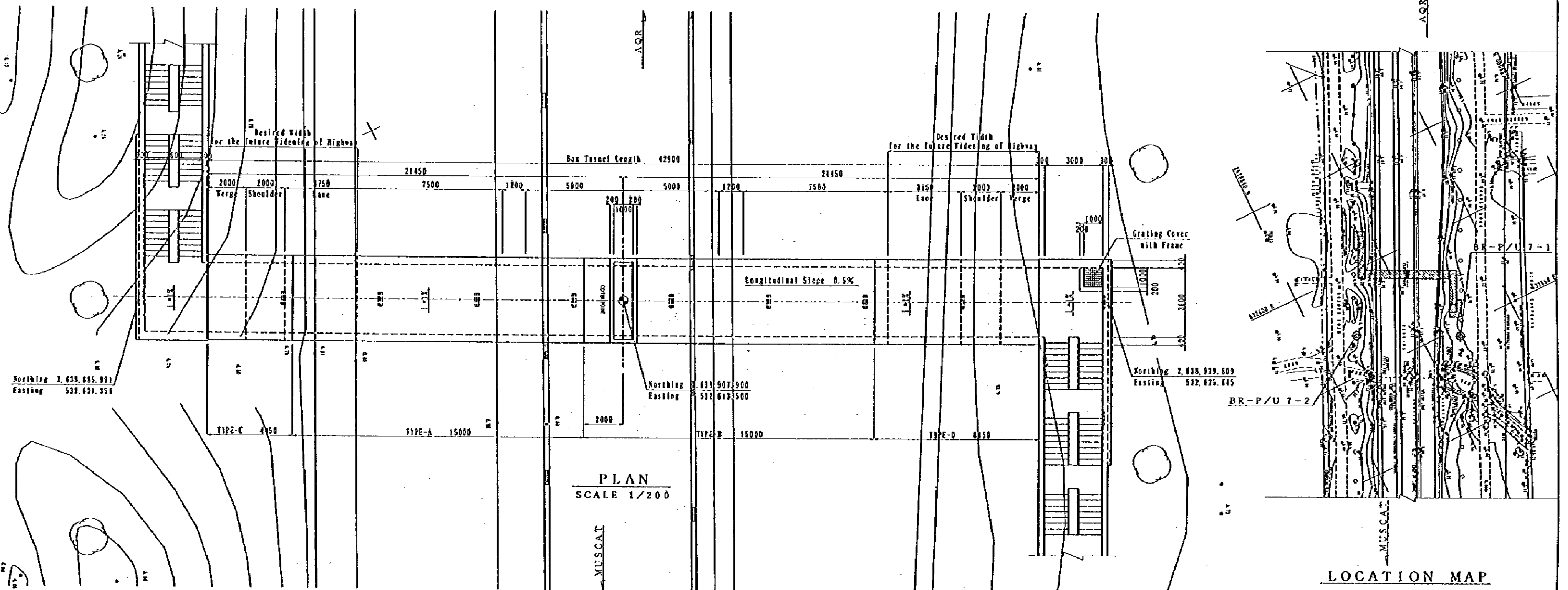
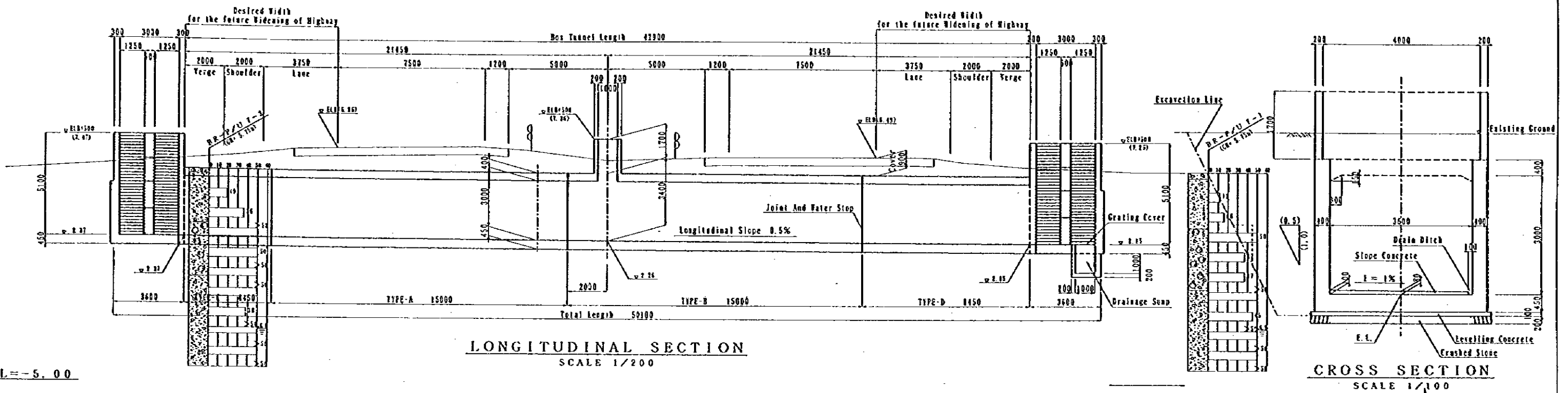

NOTES:	JAPAN INTERNATIONAL COOPERATION AGENCY (JICA)	CLIENT : MINISTRY OF COMMUNICATIONS, DIRECTORATE GENERAL OF ROADS
	JICA STUDY TEAM PACIFIC CONSULTANTS INTERNATIONAL FUKUYAMA CONSULTANTS INTERNATIONAL	PROJECT : D/D ON ROAD DEVELOPMENT PROJECT ON BATINAH HIGHWAY
		TITLE : P/U-7, AL KHADRA GENERAL VIEW (I)
		DATE : _____
		DWG NO. P-1

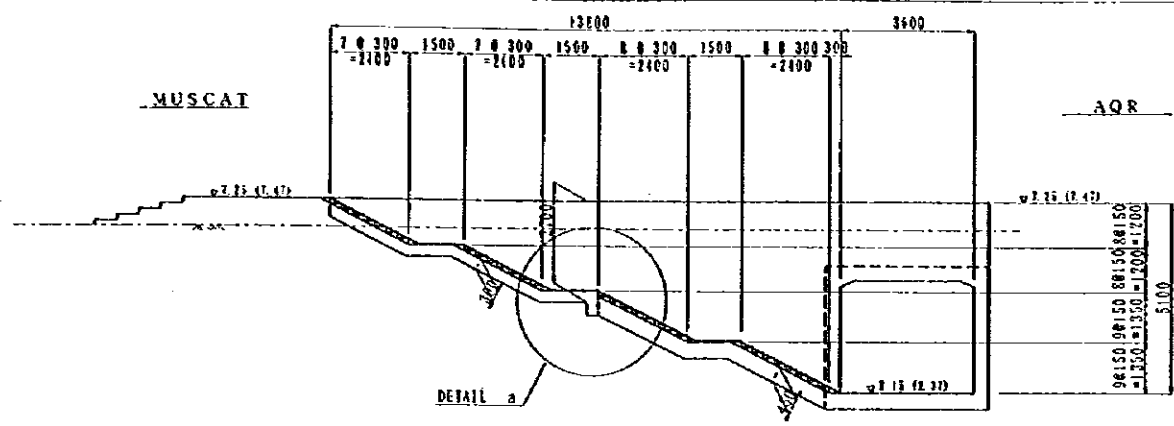

STAIR (SECTION A-A)  
SCALE 1/200

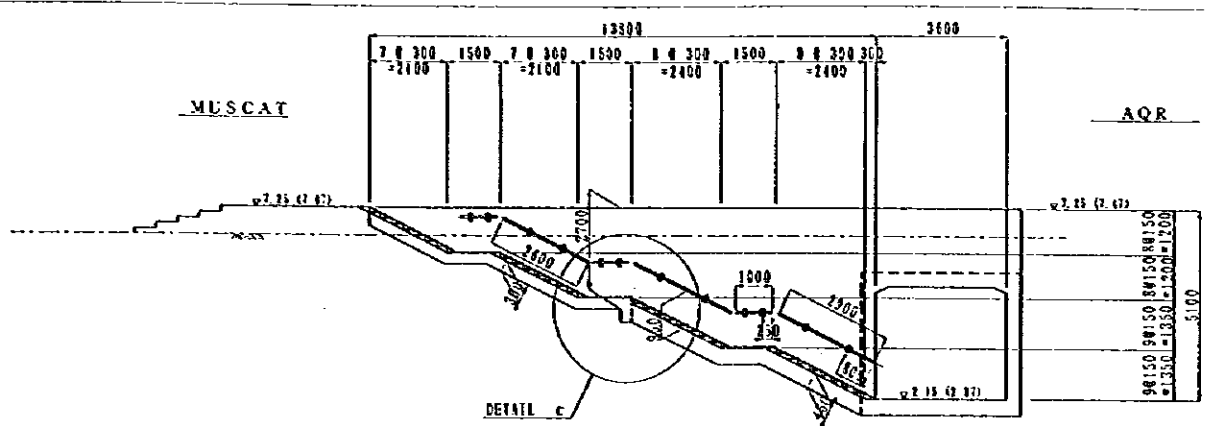

STAIR HANDRAIL (SECTION B-B)  
SCALE 1/200

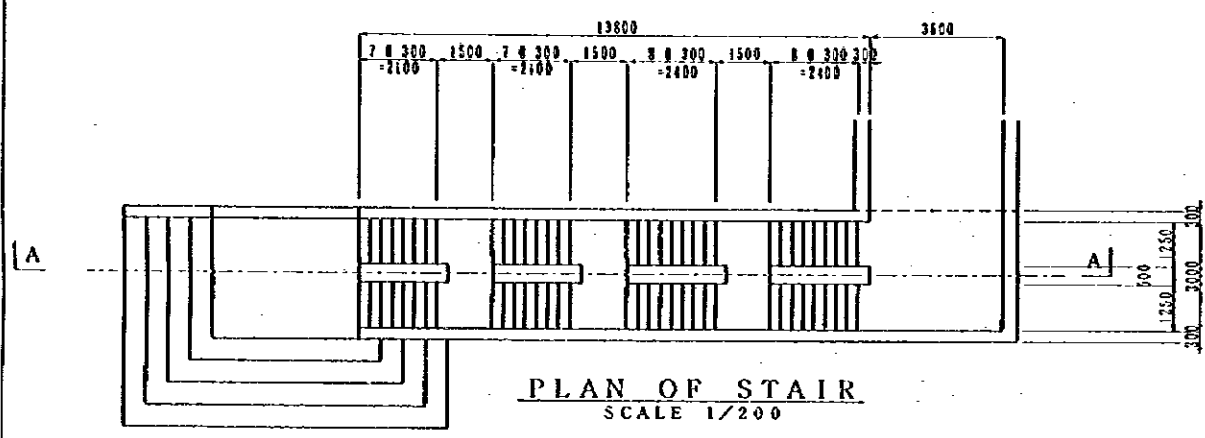

PLAN OF STAIR  
SCALE 1/200

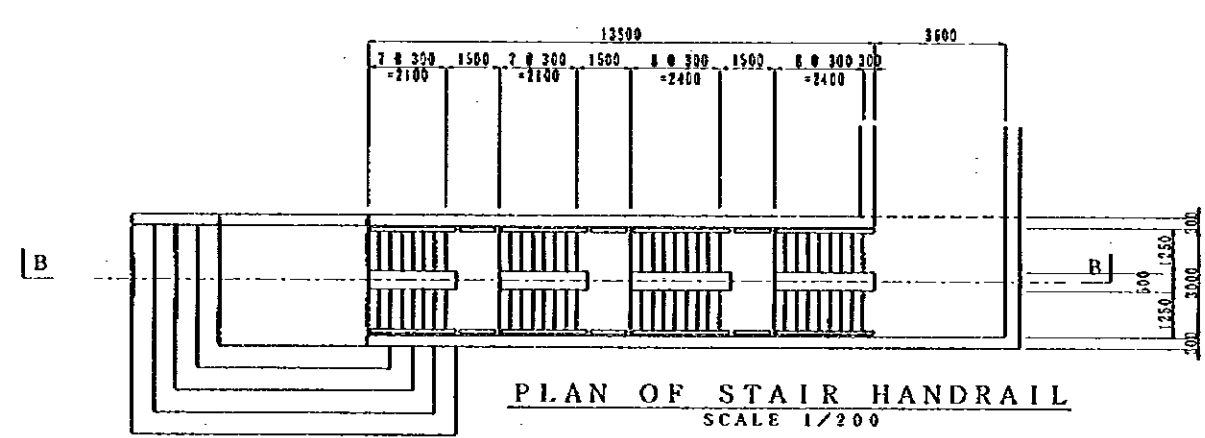

PLAN OF STAIR HANDRAIL  
SCALE 1/200

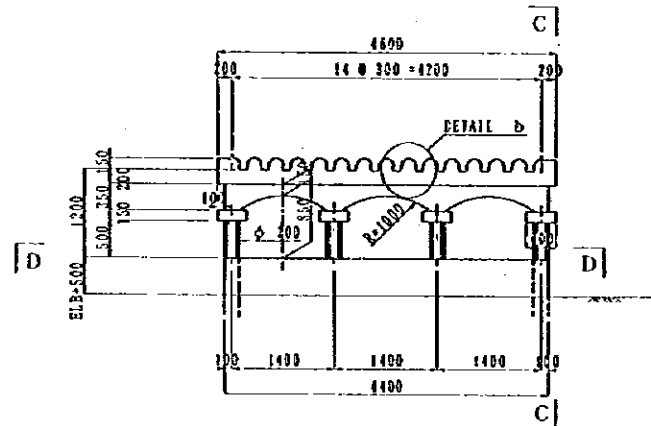

SIDE ELEVATION  
SCALE 1/100

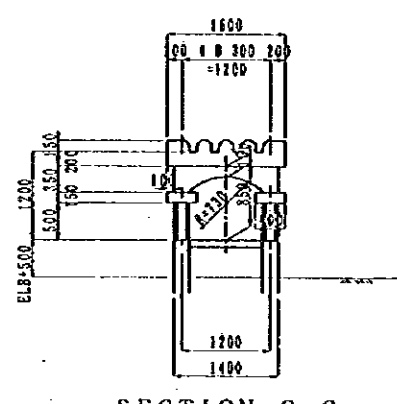

SECTION C-C  
SCALE 1/100

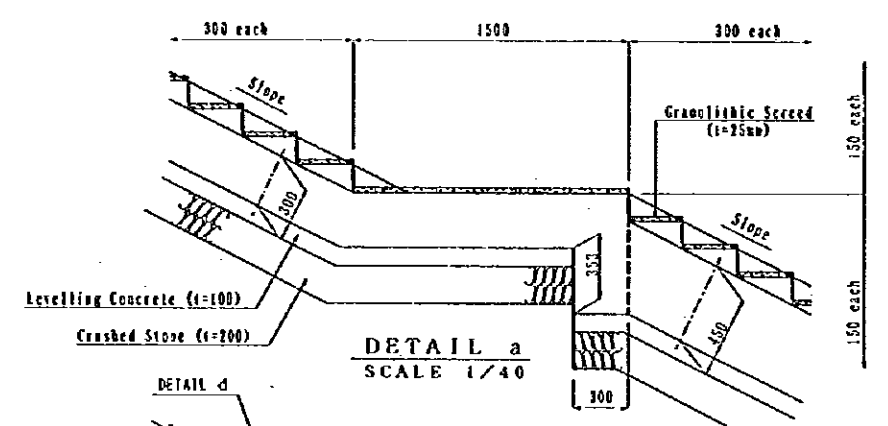

DETAIL a  
SCALE 1/40

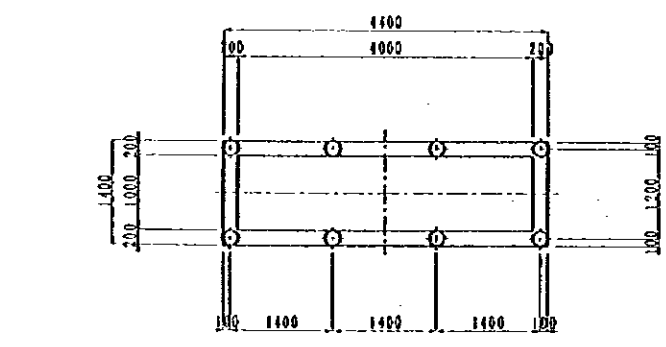

SECTION D-D  
SCALE 1/100

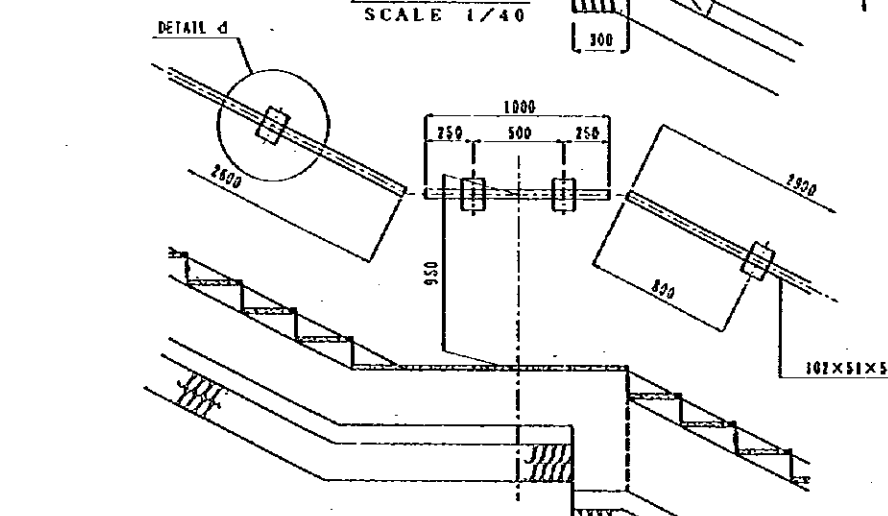

DETAIL c  
SCALE 1/40

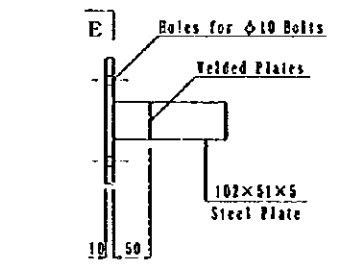

DETAIL d  
SCALE 1/10

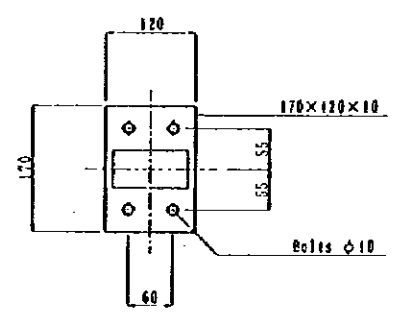

SECTION B-E  
SCALE 1/10

CANOPY ON LIGHT WELL

NOTES: Dimensions of ( ) value are for inland stair.

JAPAN INTERNATIONAL COOPERATION AGENCY (JICA)  
JICA STUDY TEAM  
PACIFIC CONSULTANTS INTERNATIONAL  
FUJYAMA CONSULTANTS INTERNATIONAL

CLIENT : MINISTRY OF COMMUNICATIONS, DIRECTORATE GENERAL OF ROADS  
PROJECT : D/D ON ROAD DEVELOPMENT PROJECT ON BATINAH HIGHWAY  
TITLE : P/U-7, AL KHADRA GENERAL VIEW (2)  
DATE :  
DWG NO. P-2

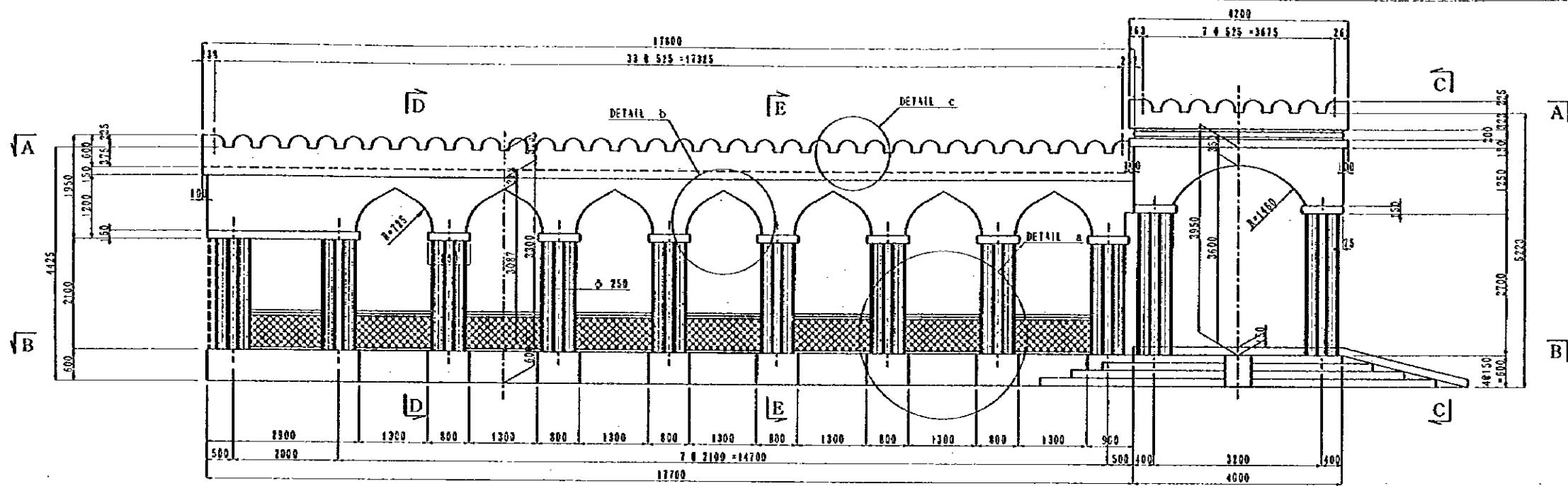

PROFILE OF CANOPY  
SCALE 1/100

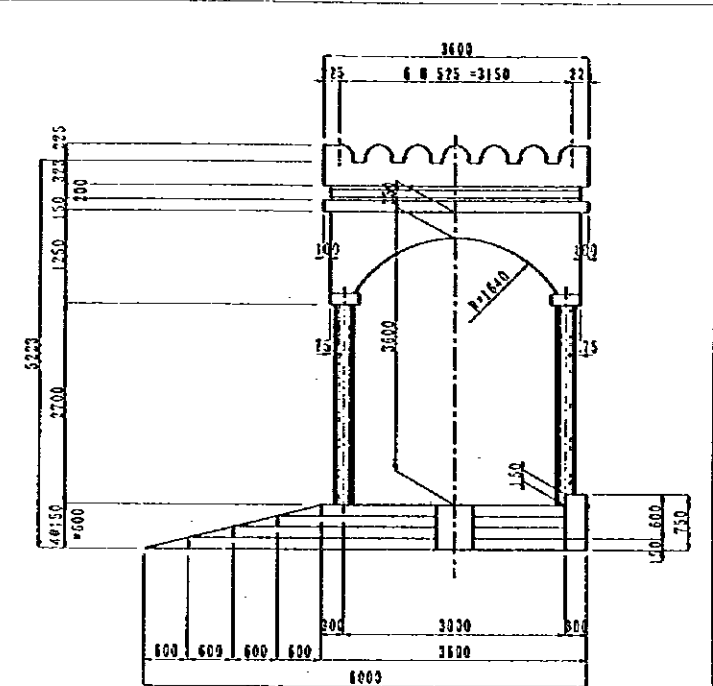

ENTRANCE (C-C)  
SCALE 1/100

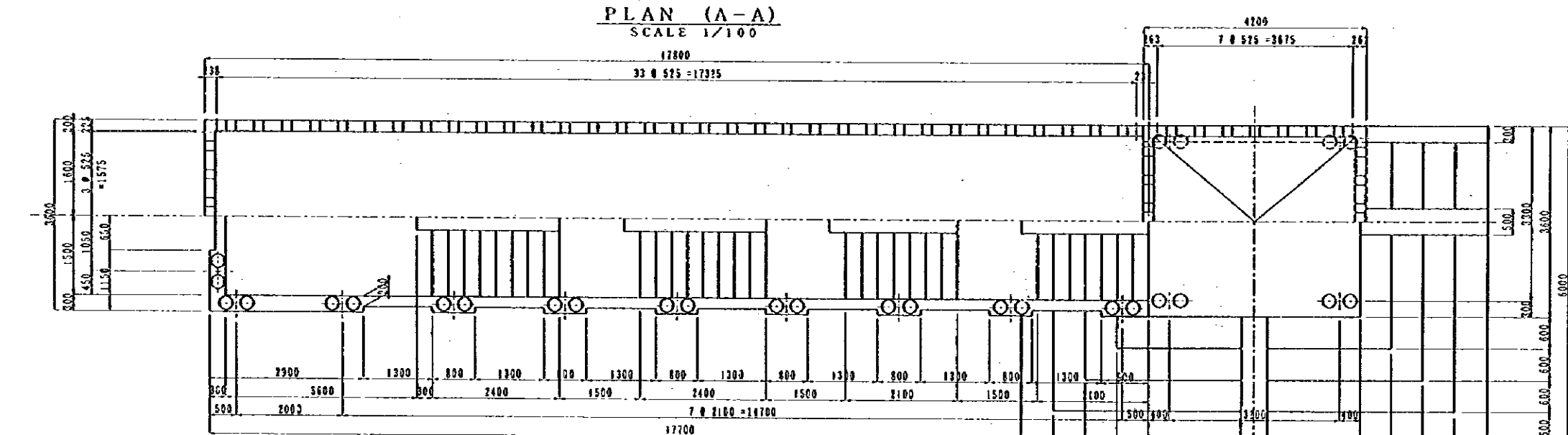

PLAN (A-A)  
SCALE 1/100

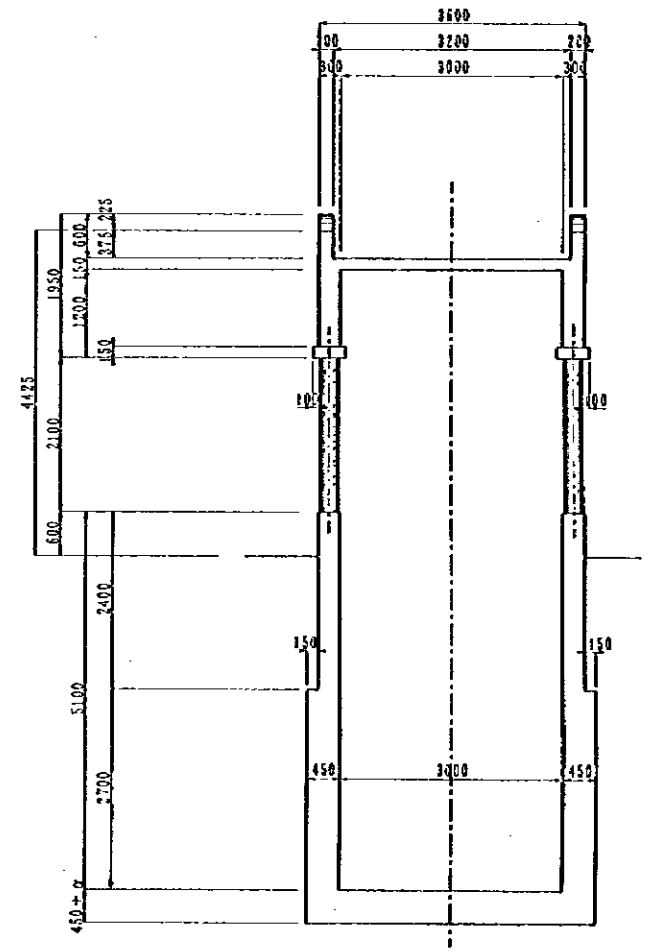

CROSS SECTION D-D  
SCALE 1/100

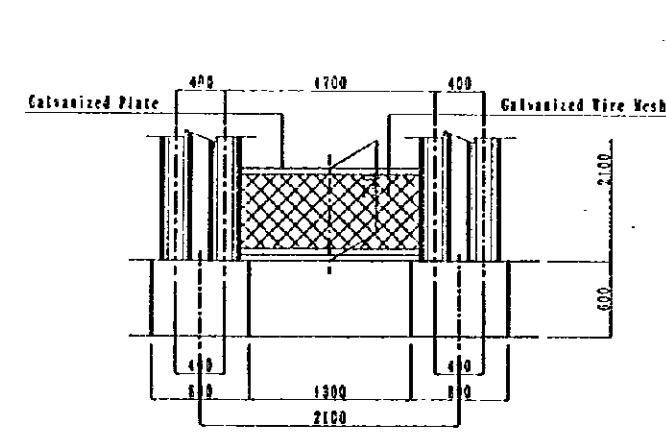

DETAIL a  
SCALE 1/60

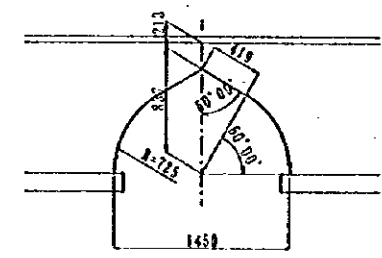

DETAIL b  
SCALE 1/60

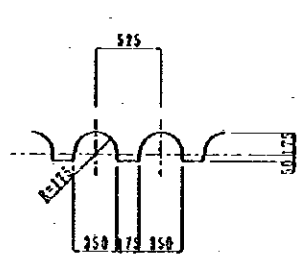

DETAIL c  
SCALE 1/60

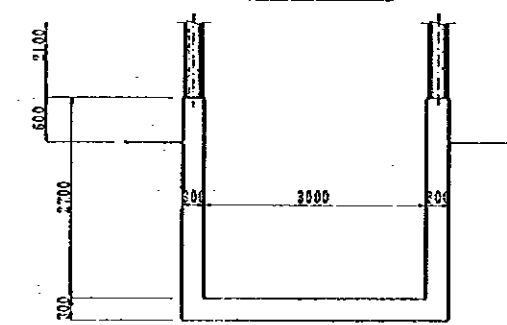

CROSS SECTION E-E  
SCALE 1/100

NOTES: Dimensions of ( ) value are for inland stair.

JAPAN INTERNATIONAL COOPERATION AGENCY  
(JICA)  
JICA STUDY TEAM  
PACIFIC CONSULTANTS INTERNATIONAL  
FLUYAMA CONSULTANTS INTERNATIONAL

CLIENT : MINISTRY OF COMMUNICATIONS, DIRECTORATE GENERAL OF ROADS  
PROJECT : D/D ON ROAD DEVELOPMENT PROJECT ON BATINAH HIGHWAY  
TITLE : P/U-7, AL KHADRA GENERAL VIEW (3)  
DATE :  
DTC NO. P-3

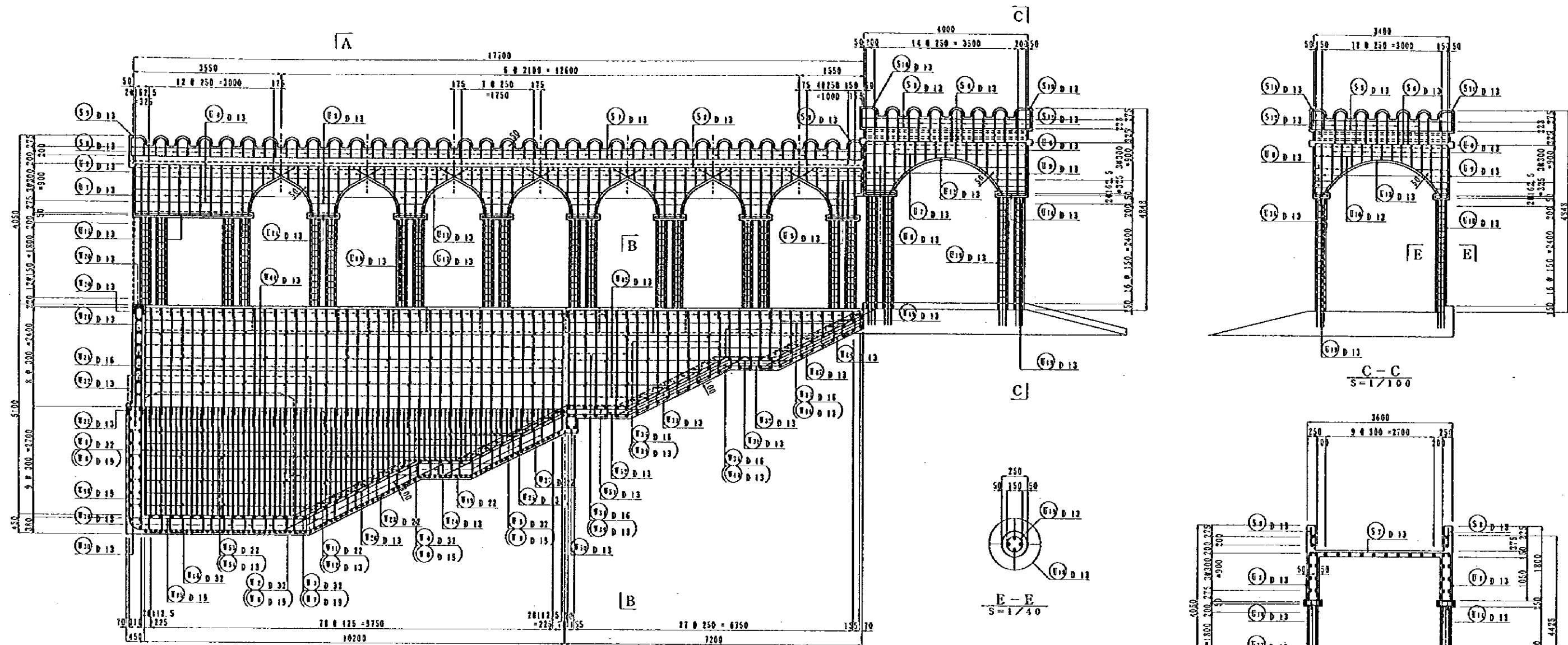

**A**  
SIDE VIEW  
S=1/100

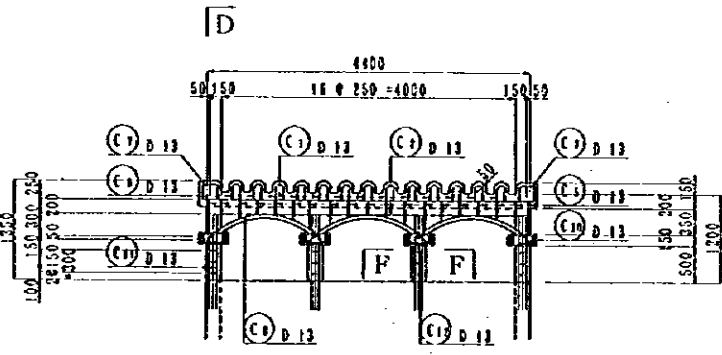

**D**  
CANOPY ON LIGHT  
S=1/100

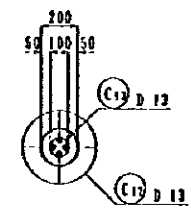

**F-F**  
S=1/40

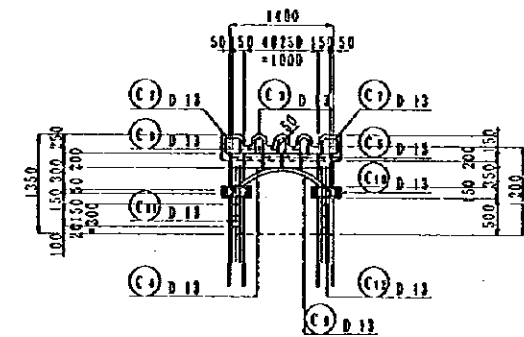

**D-D**  
S=1/100

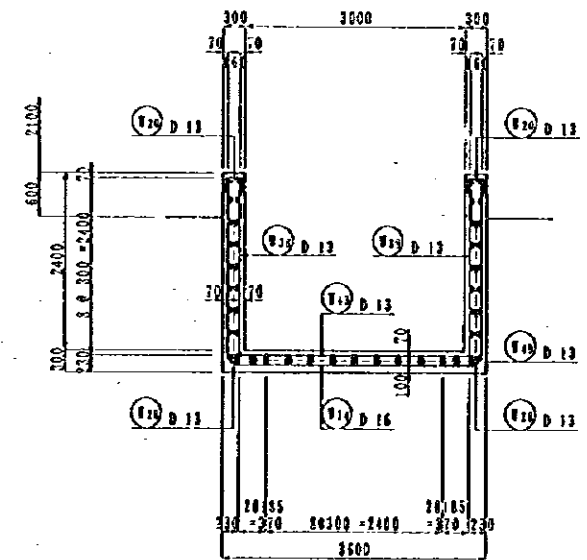

**B-B**  
S=1/100

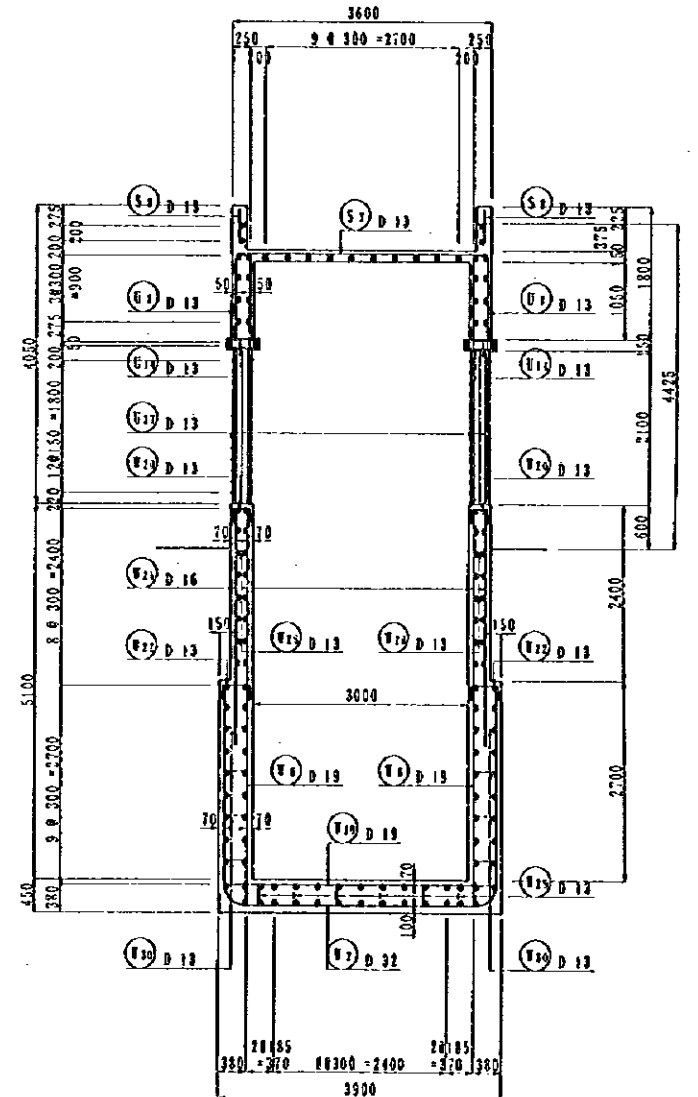

**A-A**  
S=1/100

NOTES:	JAPAN INTERNATIONAL COOPERATION AGENCY (JICA)		CLIENT : MINISTRY OF COMMUNICATIONS, DIRECTORATE GENERAL OF ROADS
	JICA STUDY TEAM PACIFIC CONSULTANTS INTERNATIONAL ELKIYANA CONSULTANTS INTERNATIONAL		PROJECT : D/D ON ROAD DEVELOPMENT PROJECT ON BATINAH HIGHWAY
			TITLE : P/U-7, AL KHADRA RE-BAR ARRANGEMENT (I)
			DATE : _____ DWG NO. P-4



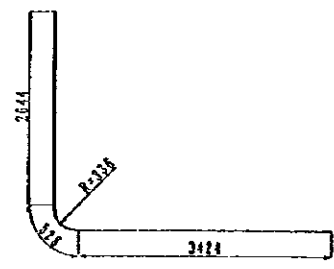

(V1) 15-D32 x 6 600

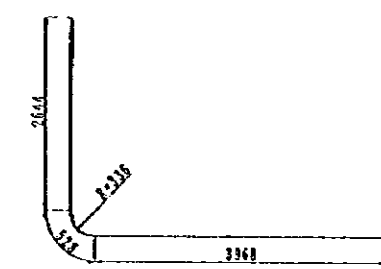

(V15) 30-D32 x 7 140

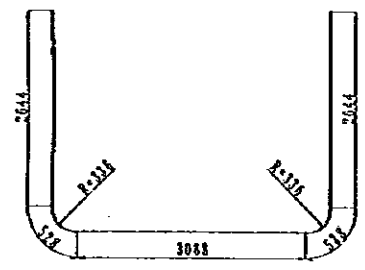

(V1) 2-D32 x 9 440

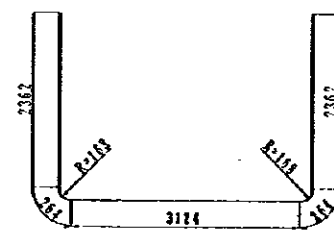

(V11) 7-D16 x 8 380

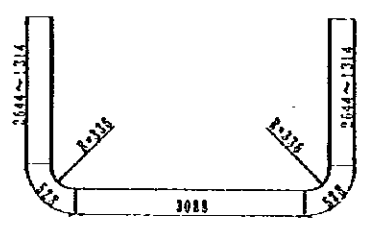

(V1) 21-D32 x 8 410

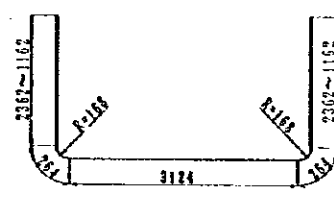

(V13) 9-D16 x 7 180

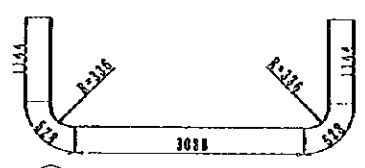

(V1) 10-D32 x 6 440

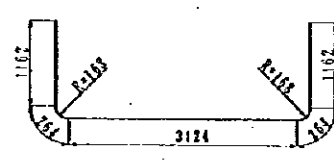

(V13) 5-D16 x 5 980

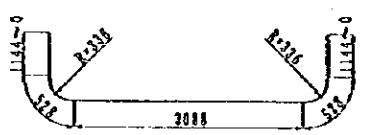

(V1) 19-D32 x 5 290

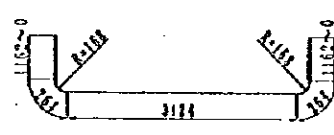

(V13) 8-D16 x 4 820

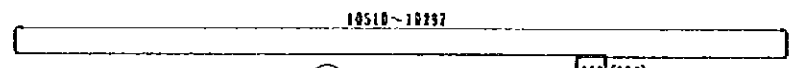
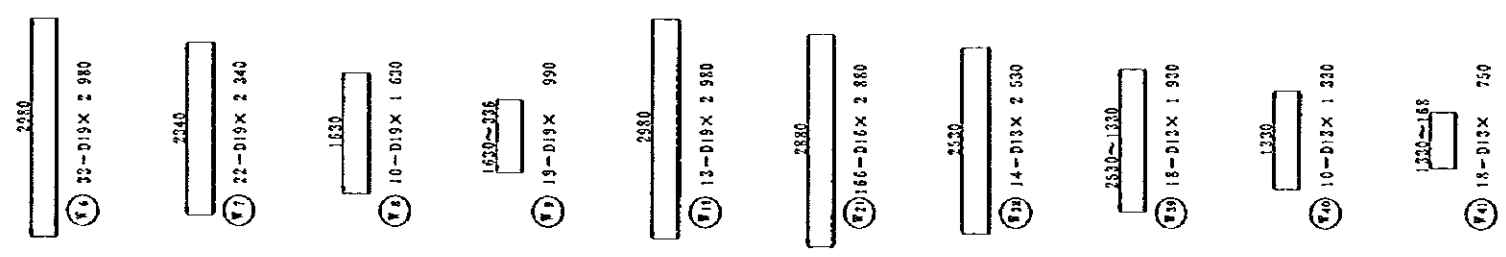

(V1) 3-D22 x (10 410+660) (60(290))  
(V12) 3-D13 x (10 410+390)

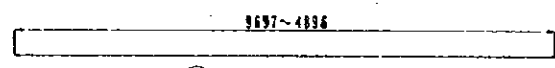

(V13) 7-D22 x 7 300  
(V14) 7-D13 x 7 300

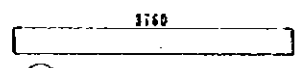

(V10) 41-D19 x 3 760

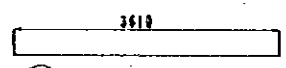

(V13) 10-D22 x 3 610  
(V14) 11-D13 x 3 610

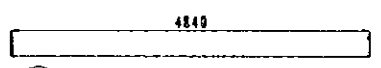

(V13) 15-D13 x 4 840

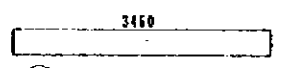

(V11) 16-D13 x 3 460

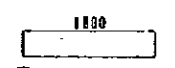

(V14) 15-D13 x 1 800  
(V13) 13-D22 x 1 800

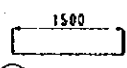

(V11) 15-D13 x 1 500  
(V12) 13-D12 x 1 500

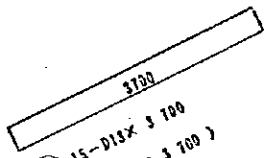

(V13) 15-D13 x 3 700  
(V12) 15-D22 x 3 700

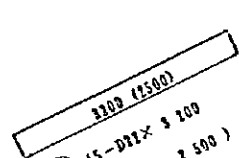

(V11) 15-D22 x 3 300  
(V12) 19-D13 x 2 500

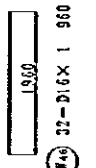

(V16) 27-D16 x 1 960

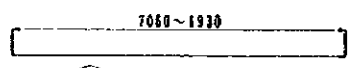

(V12) 22-D13 x 4 500

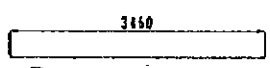

(V14) 30-D13 x 3 460

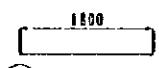

(V14) 15-D13 x 1 800

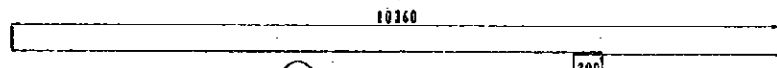

(V14) 30-D13 x (10 360+390) (290)

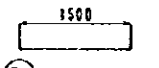

(V12) 13-D13 x 1 500

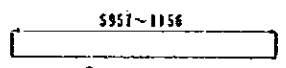

(V11) 7-D12 x 3 560  
(V12) 7-D13 x 3 560

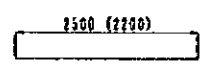

(V11) 15-D13 x 2 500  
(V13) 13-D13 x 2 200

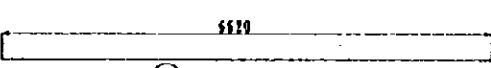

(V13) 2-D13 x 6 670

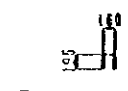

(V12) 155-D13 x 550

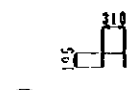

(V12) 79-D13 x 700

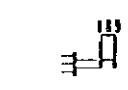

(V12) 71-D13 x 420

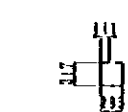

(V12) 117-D13 x 1 160

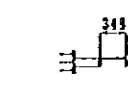

(V12) 60-D13 x 550

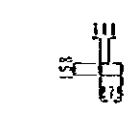

(V12) 78-D13 x 820

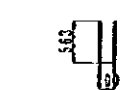

(V12) 15-D13 x 1 330

NOTES:	JAPAN INTERNATIONAL COOPERATION AGENCY (JICA)	CLIENT : MINISTRY OF COMMUNICATIONS, DIRECTORATE GENERAL OF ROADS
	JICA STUDY TEAM PACIFIC CONSULTANTS INTERNATIONAL PERUYAMA CONSULTANTS INTERNATIONAL	PROJECT : D/D ON ROAD DEVELOPMENT PROJECT ON BATINAH HIGHWAY
		TITLE : P/U-7, AL KHADRA RE-BAR ARRANGEMENT (2)
		DATE : DNG NO. P-5

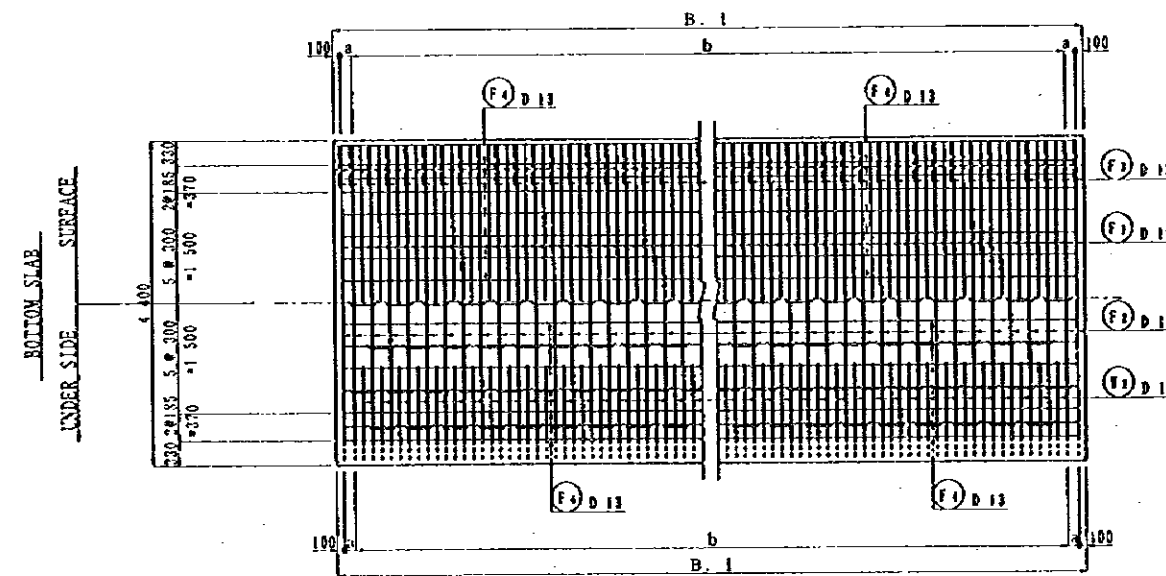
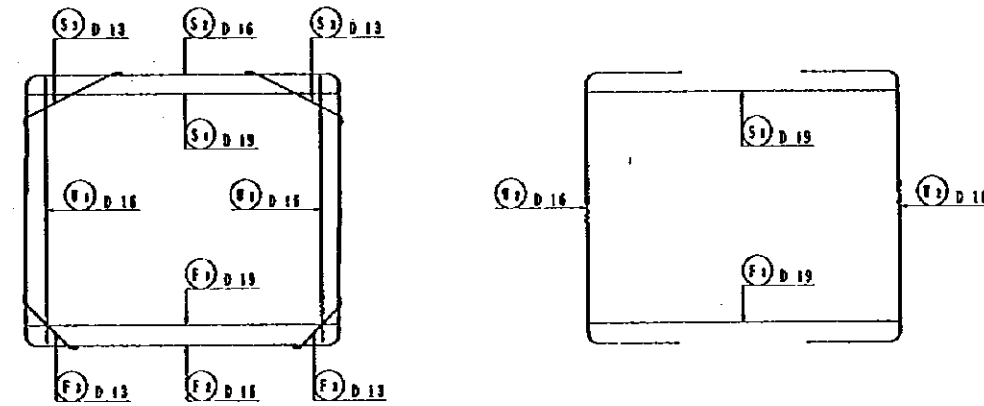
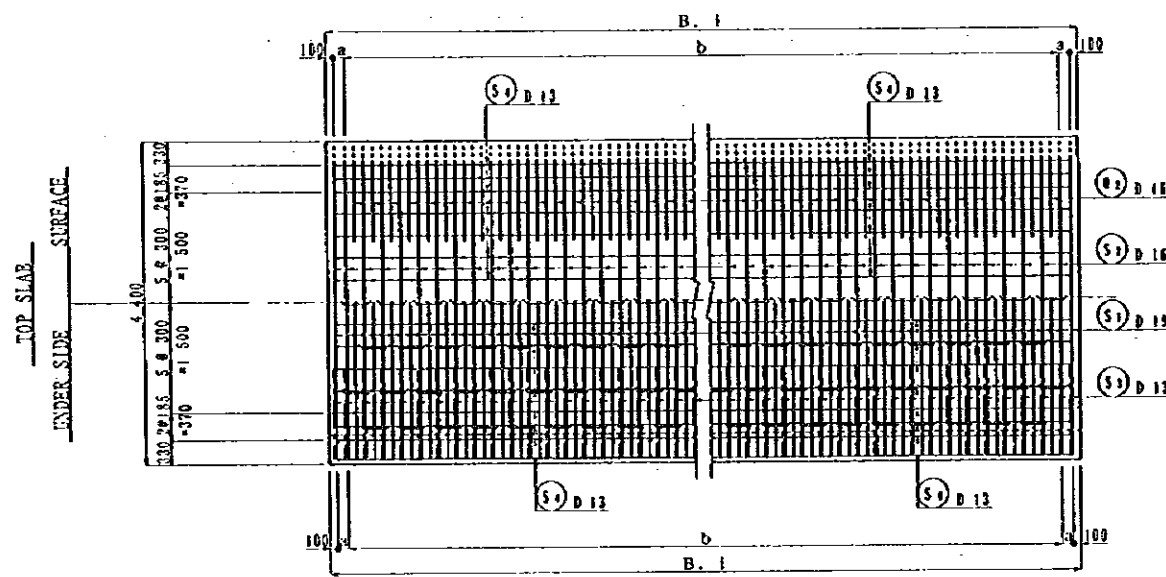
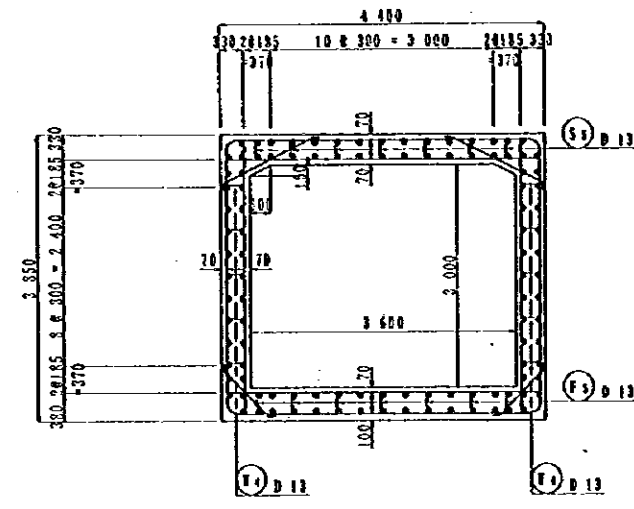
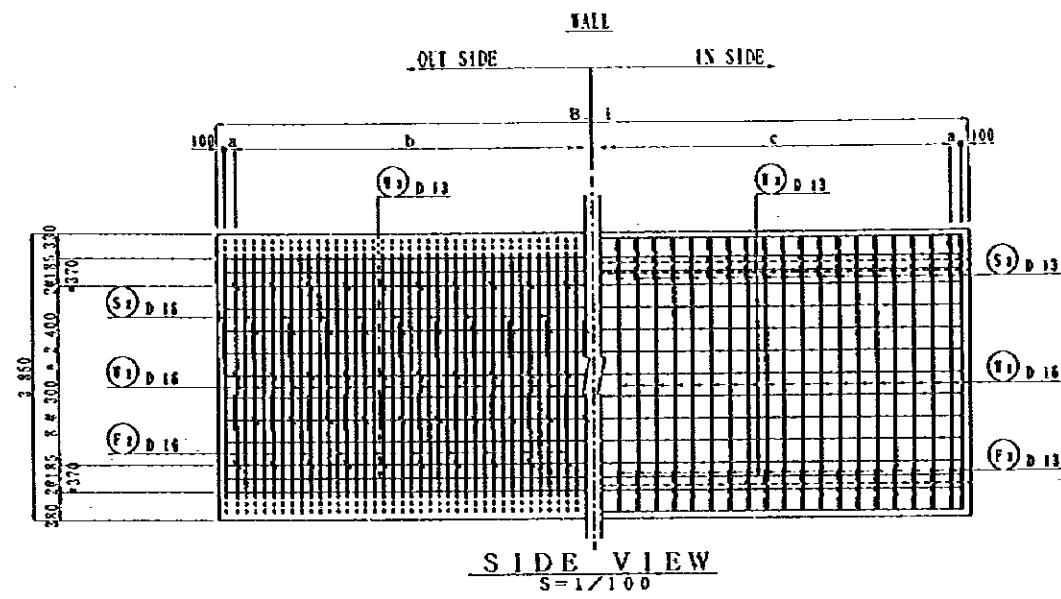

	B. I	a	b	c
TYPE A	15 000	150	116 @ 125	58 @ 250
TYPE C	4 450	—	34 @ 125	17 @ 250
TYPE D	8 450	—	66 @ 125	33 @ 250

PLAN  
S=1/100

NOTES:

JAPAN INTERNATIONAL COOPERATION AGENCY  
(JICA)  
JICA SILBY TEAM  
PACIFIC CONSULTANTS INTERNATIONAL  
FLUYAMA CONSULTANTS INTERNATIONAL

CLIENT : MINISTRY OF COMMUNICATIONS, DIRECTORATE GENERAL OF ROADS  
PROJECT : D/D ON ROAD DEVELOPMENT PROJECT ON BATINAH HIGHWAY  
TITLE : P/U-7, AL KHADRA RE-BAR ARRANGEMENT (4)  
DATE : \_\_\_\_\_ DWG NO. P-7

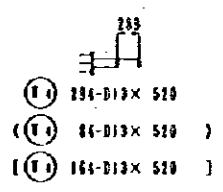
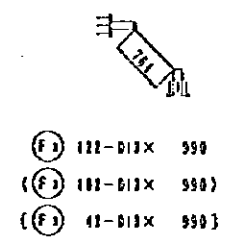
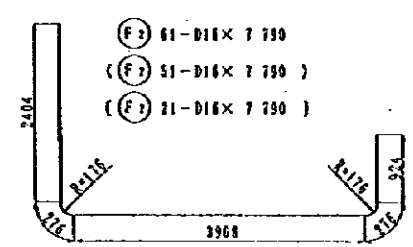
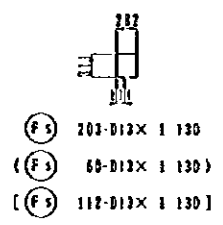
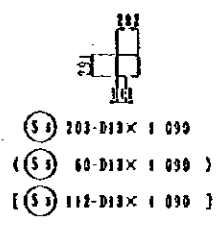
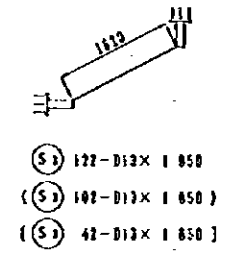
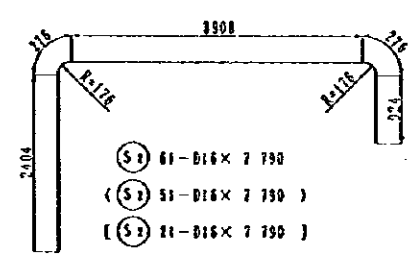
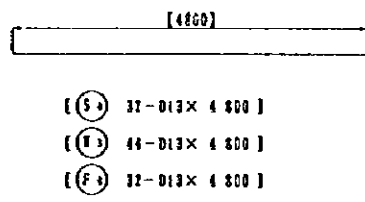
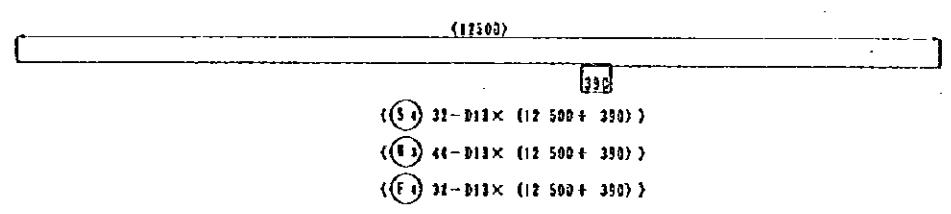
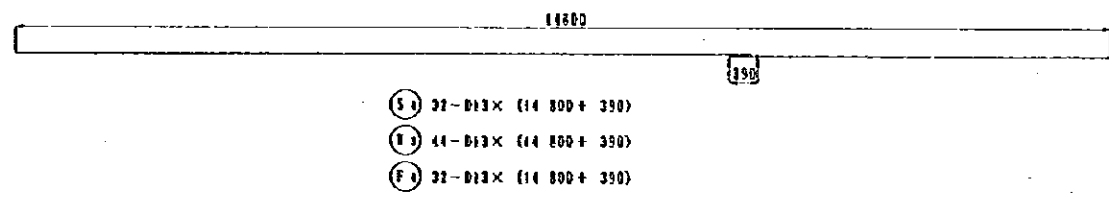
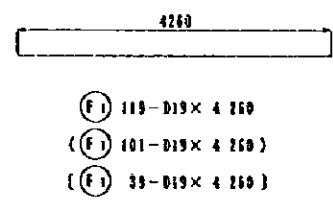
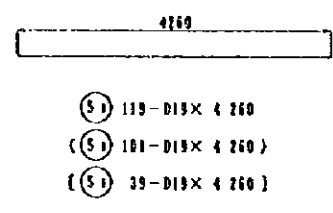
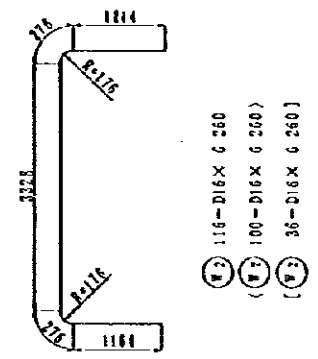
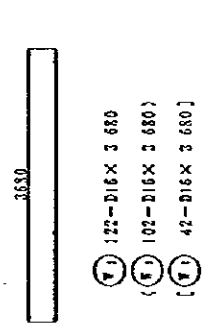

REIN. NO.	Ø (mm)	LENGTH (mm)	VOLUME WEIGHT	NLMS	E WEIGHT	WEIGHT	REMARKS
<b>TYPE-A</b>							
S 1	D 19	4 260	2.235	119	9.521	1133.0	—
2	D 16	7 790	1.552	61	12.090	737.5	—
3	D 13	1 850	0.994	122	1.239	151.4	—
4	"	15 190	"	32	15.099	483.2	—
5	"	1 090	"	203	1.083	219.9	—
<b>TYPE-B</b>							
W 1	D 16	3 680	1.552	172	5.711	696.7	—
2	"	6 260	"	116	9.716	1127.1	—
3	D 13	15 150	0.994	44	15.099	664.4	—
4	"	520	"	294	0.517	152.0	—
<b>TYPE-C</b>							
F 1	D 19	4 260	2.235	119	9.521	1133.0	—
2	D 16	7 790	1.552	61	12.090	737.5	—
3	D 13	950	0.994	122	0.994	120.0	—
4	"	15 190	"	32	15.099	483.2	—
5	"	1 130	"	203	1.123	228.0	—
<b>TYPE-D</b>							
S 1	D 19	4 260	2.235	35	9.521	332.2	—
2	D 16	7 790	1.552	18	12.090	217.6	—
3	D 13	950	0.994	36	0.994	35.4	—
4	"	4 250	"	32	4.225	135.2	—
5	"	1 130	"	60	1.123	67.4	—
<b>TYPE-E</b>							
S 1	D 19	4 260	2.235	67	9.521	637.9	—
2	D 16	7 790	1.552	34	12.090	411.1	—
3	D 13	1 850	0.994	68	1.239	125.1	—
4	"	8 250	"	32	8.201	262.4	—
5	"	1 090	"	112	1.083	121.3	—
<b>TYPE-F</b>							
W 1	D 16	3 680	1.552	68	5.711	389.3	—
2	"	6 260	"	66	9.716	641.3	—
3	D 13	8 250	0.994	44	8.201	360.8	—
4	"	520	"	164	0.517	84.8	—
<b>TYPE-G</b>							
F 1	D 19	4 260	2.235	67	9.521	637.9	—
2	D 16	7 790	1.552	34	12.090	411.1	—
3	D 13	950	0.994	68	0.994	66.9	—
4	"	8 250	"	32	8.201	262.4	—
5	"	1 130	"	112	1.123	125.0	—
<b>TOTAL WEIGHT</b>							
						D 19	4208.2
						D 16	6121.7
						D 13	4718.3
						<b>TOTAL WEIGHT</b>	<b>15048.2</b>

NOTES: { } TYPE-C  
[ ] TYPE-D

JAPAN INTERNATIONAL COOPERATION AGENCY (JICA)  
JICA STUDY TEAM  
PACIFIC CONSULTANTS INTERNATIONAL  
FUKUYAMA CONSULTANTS INTERNATIONAL

CLIENT : MINISTRY OF COMMUNICATIONS, DIRECTORATE GENERAL OF ROADS  
PROJECT : D/D ON ROAD DEVELOPMENT PROJECT ON BATINAH HIGHWAY  
TITLE : P/U-7, AL KHADRA RE-BAR ARRANGEMENT (5)  
DATE :  
DWG NO. P-8

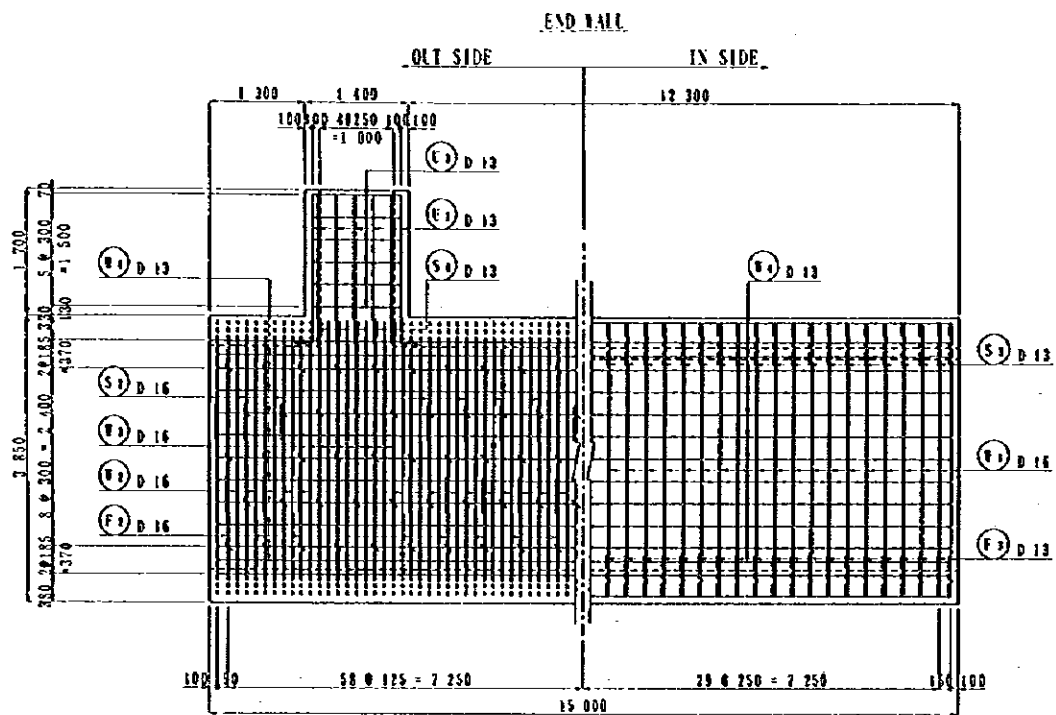

SIDE VIEW  
S=1/100

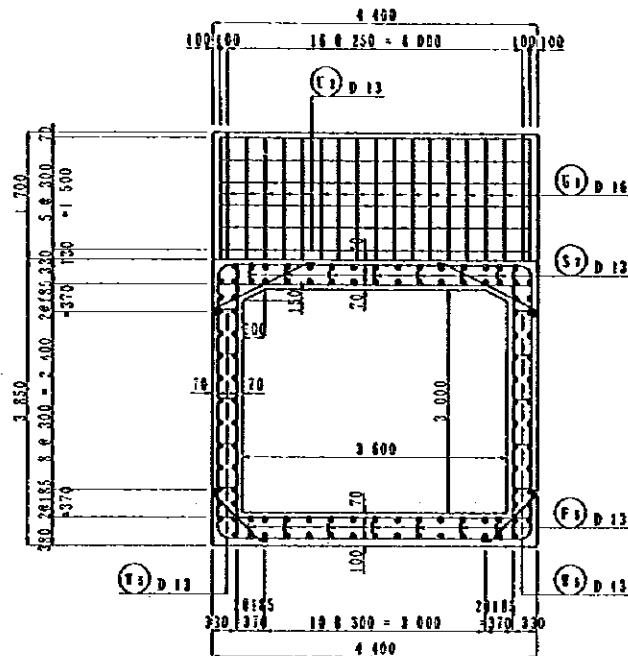

SECTION  
S=1/100

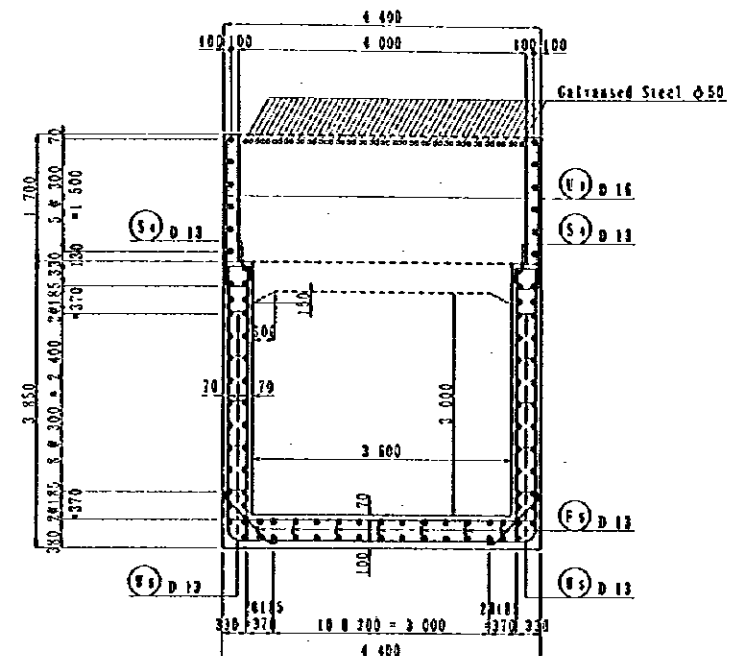

A-A  
S=1/100

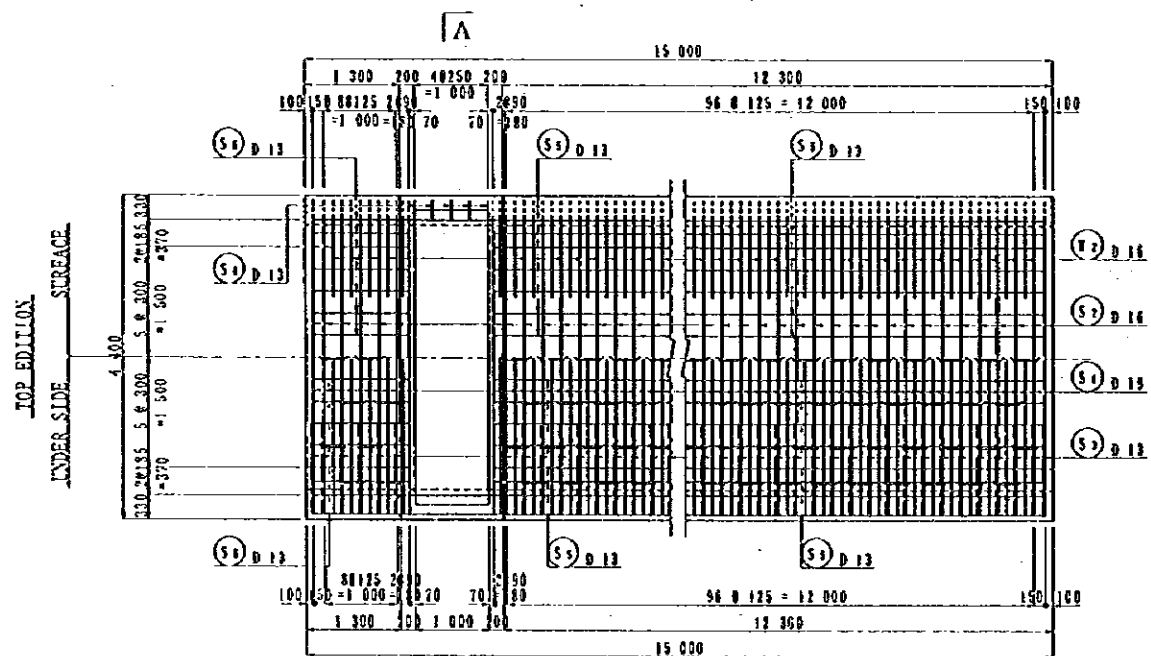

PLAN  
S=1/100

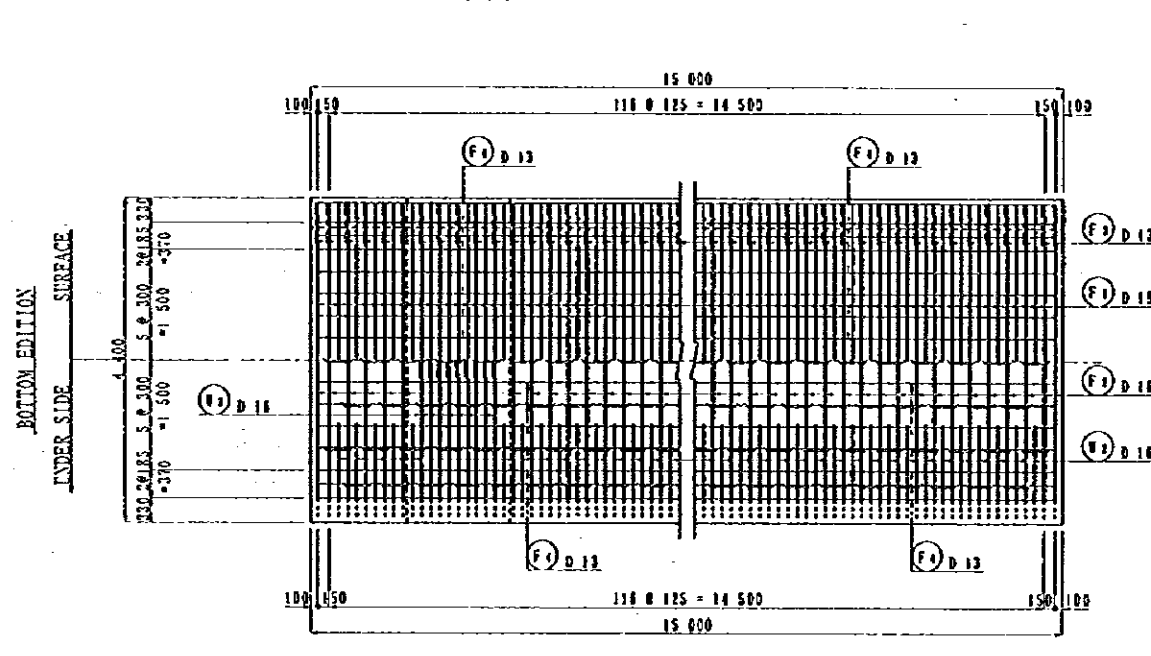

PLAN  
S=1/100

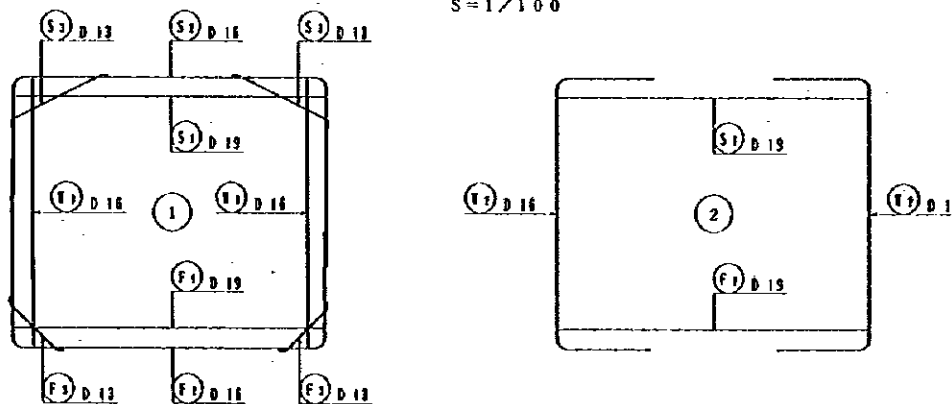
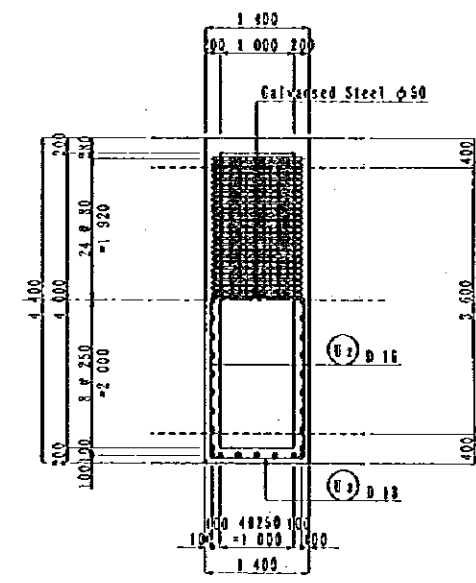
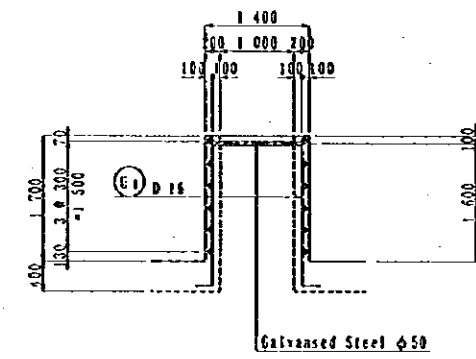

NOTES:

JAPAN INTERNATIONAL COOPERATION AGENCY  
(JICA)  
JICA STUDY TEAM  
PACIFIC CONSULTANTS INTERNATIONAL  
FUKUYAMA CONSULTANTS INTERNATIONAL

CLIENT : MINISTRY OF COMMUNICATIONS, DIRECTORATE GENERAL OF ROADS  
PROJECT : D/D ON ROAD DEVELOPMENT PROJECT ON BATINAH HIGHWAY  
TITLE : P/U-7, AL KHADRA RE-BAR ARRANGEMENT (6)  
DATE :  
DWG NO. P-9

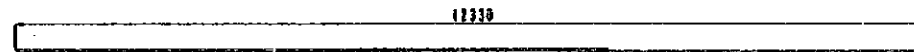
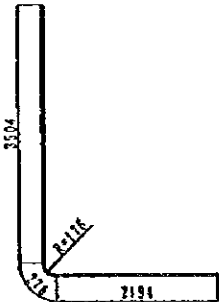
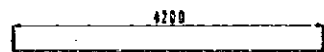
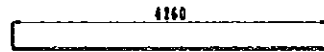
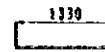
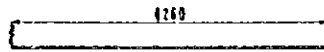
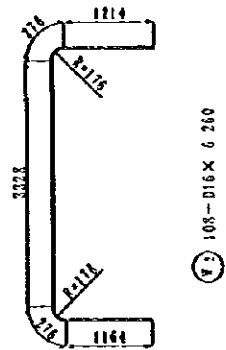
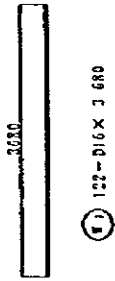

- (E) 48-D13 x (12 330 + 390)
- (F) 32-D13 x (12 330 + 390)
- (S) 32-D13 x (12 330 + 390)

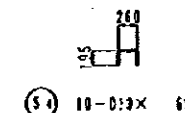
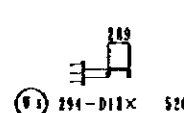
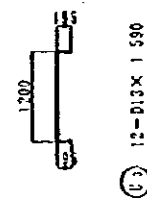
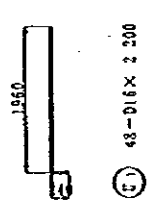
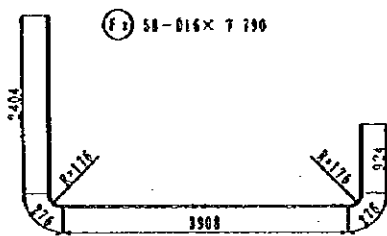
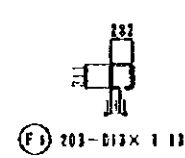
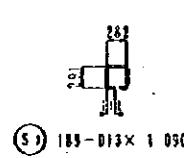
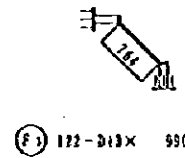
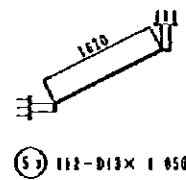
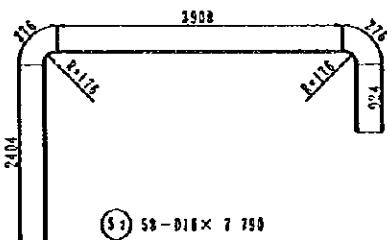

REIN NO.	Ø (mm)	LENGTH (mm)	NOMINAL WEIGHT	NLWS	E WEIGHT	WEIGHT	REMARKS
<b>TYPE - B</b>							
S 1	D 13	4 260	2.235	111	9.585	1058.0	12/110
3	D 16	7 750	1.552	58	12.030	701.2	
2	D 13	1 850	0.994	112	1.801	208.2	
4	"	650	"	10	0.645	6.5	
5	"	12 720	"	32	12.648	404.6	
6	"	1 330	"	32	1.312	42.3	
7	"	1 050	"	189	1.083	204.2	
Y 1	D 16	2 630	1.552	122	5.711	696.2	12/110
2	"	6 260	"	103	9.716	1049.3	
3	"	5 980	"	18	9.281	167.1	
4	D 13	12 720	0.994	44	12.648	558.3	
5	"	520	"	294	0.517	152.0	
F 1	D 16	4 260	2.235	119	9.521	1133.0	12/110
2	D 16	7 750	1.552	58	12.030	701.2	
3	D 13	950	0.994	122	0.984	120.0	
4	"	12 720	"	32	12.648	404.6	
5	"	1 130	"	203	1.123	228.0	
U 1	D 16	2 200	1.552	43	3.414	163.9	12/110
2	D 13	4 200	0.994	12	4.175	50.1	
3	"	1 550	"	12	1.580	19.0	
						D 15	2189.8
						D 16	3479.4
						D 13	2334.1
						<b>TOTAL WEIGHT</b>	<b>8063.3</b>

NOTES:

JAPAN INTERNATIONAL COOPERATION AGENCY (JICA)

JICA STUDY TEAM  
PACIFIC CONSULTANTS INTERNATIONAL  
FUKUYAMA CONSULTANTS INTERNATIONAL

CLIENT : MINISTRY OF COMMUNICATIONS, DIRECTORATE GENERAL OF ROADS

PROJECT : D/D ON ROAD DEVELOPMENT PROJECT ON BATINAH HIGHWAY

TITLE : P/U-7, AL KHADRA RE-BAR ARRANGEMENT (?)

DATE : \_\_\_\_\_ DWG NO. P - 10

FIRST CONSTRUCTION STAGE

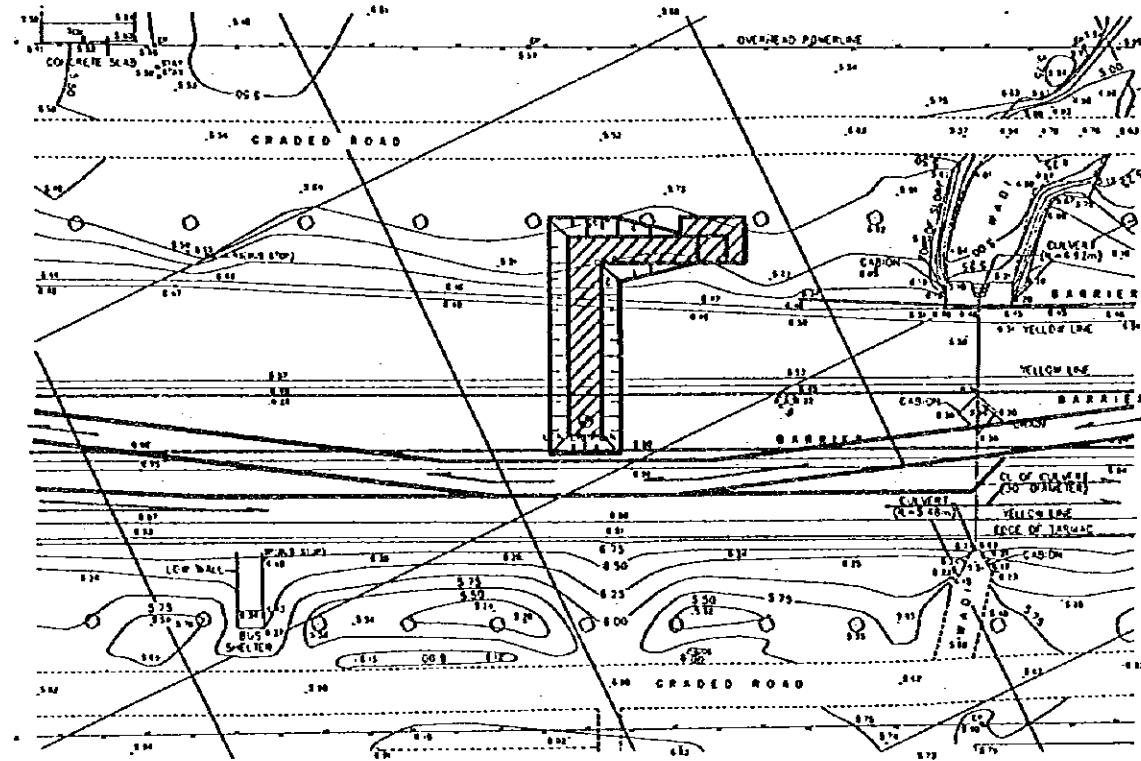

SECOND CONSTRUCTION STAGE

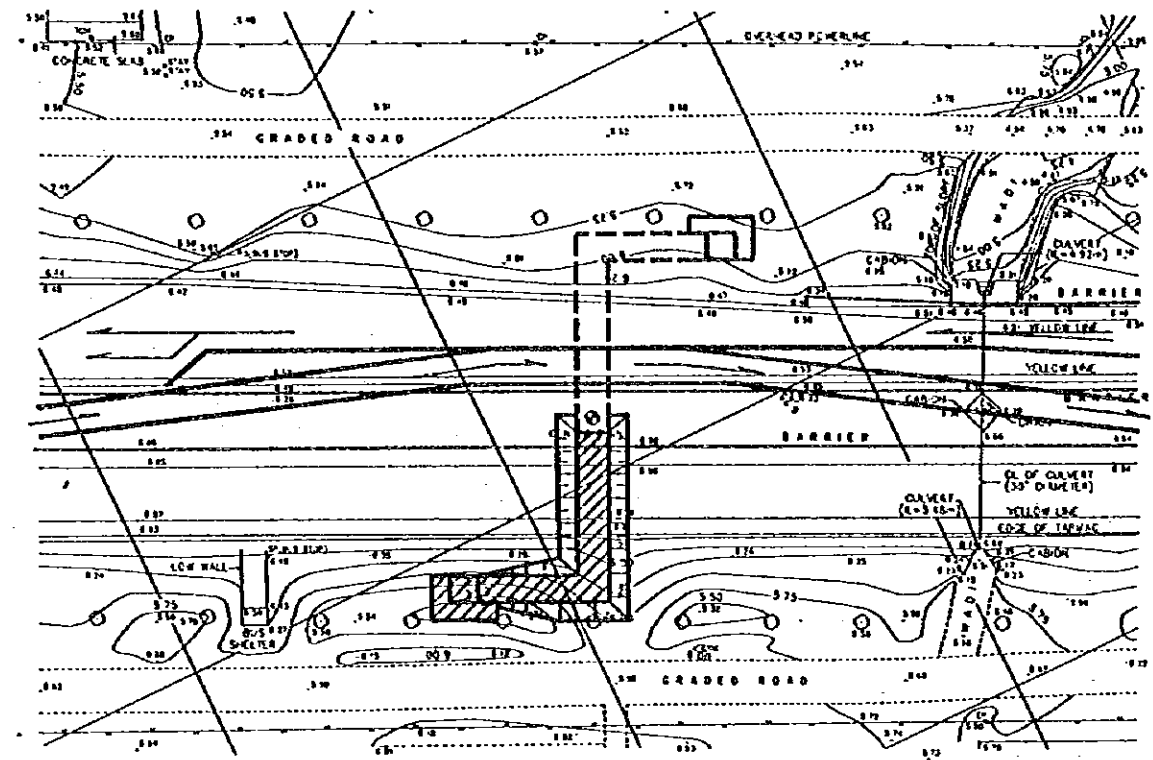

THIRD CONSTRUCTION STAGE

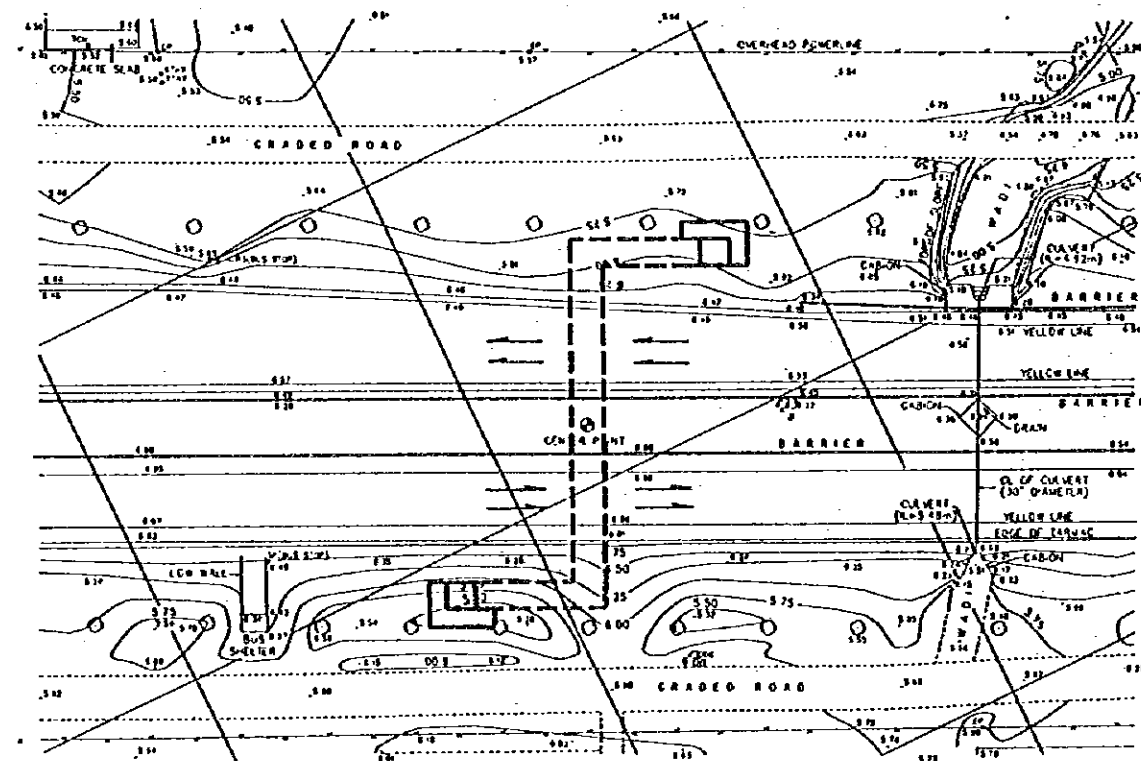

FIRST CONSTRUCTION STAGE

1. Divert traffic from the existing carriageway and demarcate the yard for the first stage of construction.
2. Carry out the first stage of construction for the underpass.
3. After completion of first stage of construction, restore the existing carriageway to allow traffic flow.

SECOND CONSTRUCTION STAGE

1. Divert traffic from the other carriageway and demarcate the yard for the second stage of construction.
2. Carry out the second stage of construction for the underpass.
3. After completion of second stage of construction, restore the existing carriageway to allow traffic flow.

THIRD CONSTRUCTION STAGE

1. Carry out accessory installation work for pedestrian underpass and open it to use.
2. Construction completed.

NOTES:

JAPAN INTERNATIONAL COOPERATION AGENCY (JICA) JICA STUDY TEAM PACIFIC CONSULTANTS INTERNATIONAL FUKUYAMA CONSULTANTS INTERNATIONAL	CLIENT: MINISTRY OF COMMUNICATIONS, DIRECTORATE GENERAL OF ROADS	
	PROJECT: D/D ON ROAD DEVELOPMENT PROJECT ON BATINAH HIGHWAY	
	TITLE	SEQUENCE OF AL KHADRA P/U CONSTRUCTION
	DATE	DWGNO. T-1

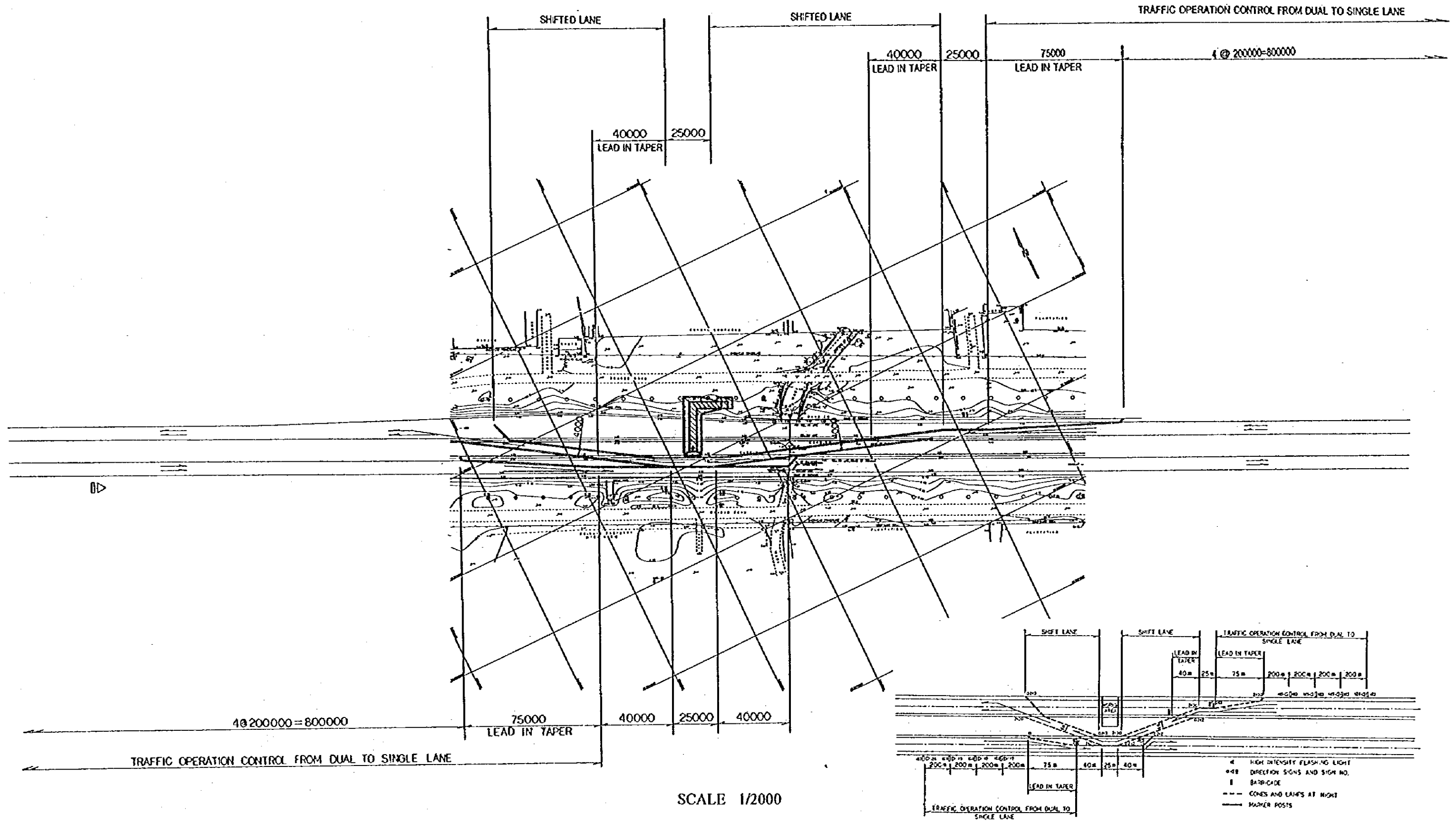

GENERAL LAYOUT PLAN OF P/U WORKS

NOTES:

JAPAN INTERNATIONAL COOPERATION AGENCY  
(JICA)  
JICA STUDY TEAM  
PACIFIC CONSULTANTS INTERNATIONAL  
FUKUYAMA CONSULTANTS INTERNATIONAL

CLIENT: MINISTRY OF COMMUNICATIONS, DIRECTORATE GENERAL OF ROADS  
PROJECT: D/D ON ROAD DEVELOPMENT PROJECT ON BATINAH HIGHWAY  
TITLE: DETOUR LAYOUT OF AL KHADRA P/U WORKS  
DATE: \_\_\_\_\_ DWGNO. T-2

