

INVENTORY OF PAVEMENT SURFACE CONDITION

Date : 11-15-95

Km. 1132+000

Sheet No : 1/2

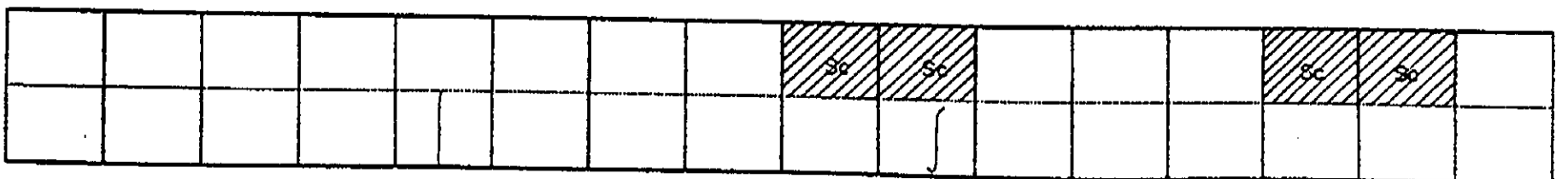
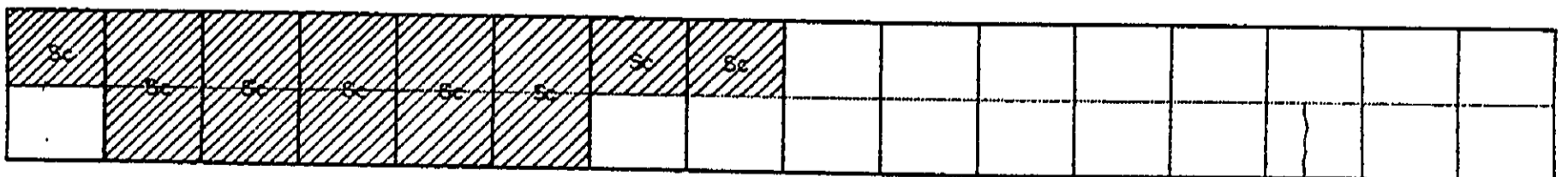
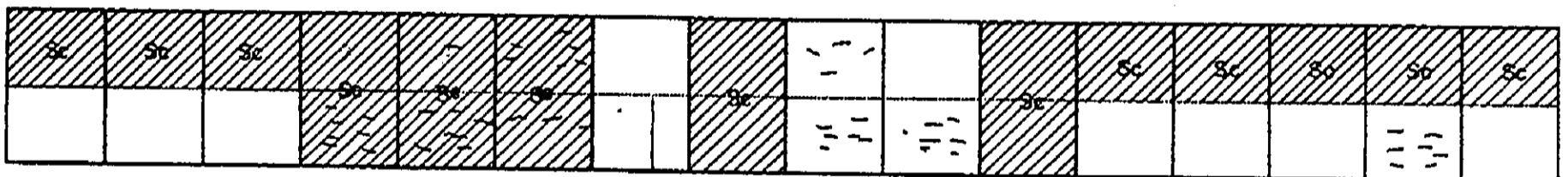
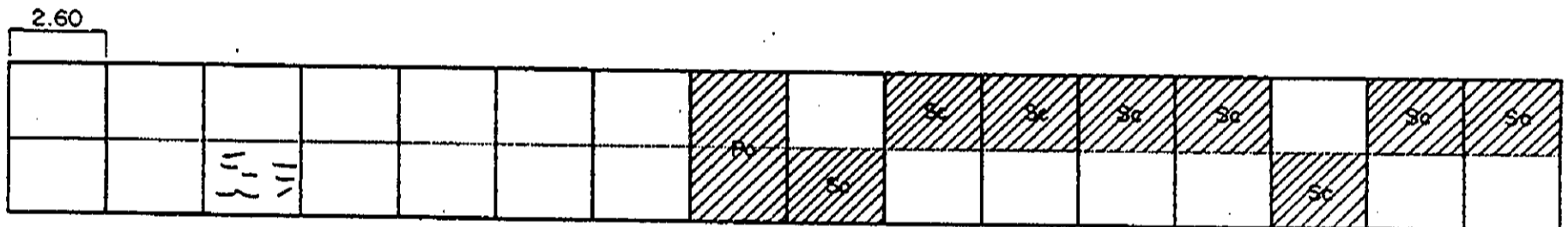
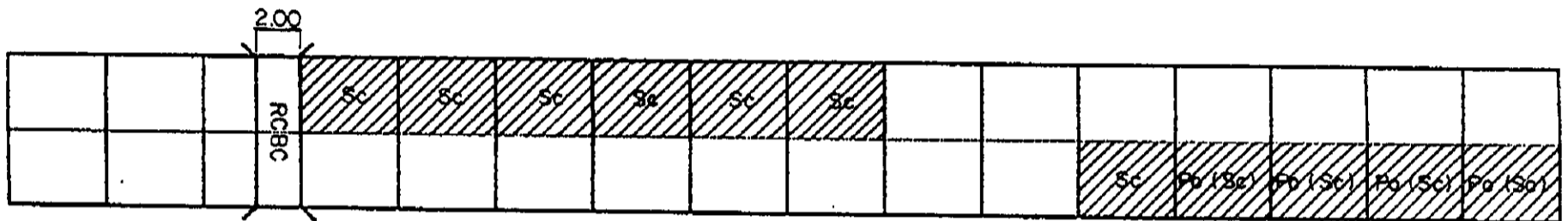
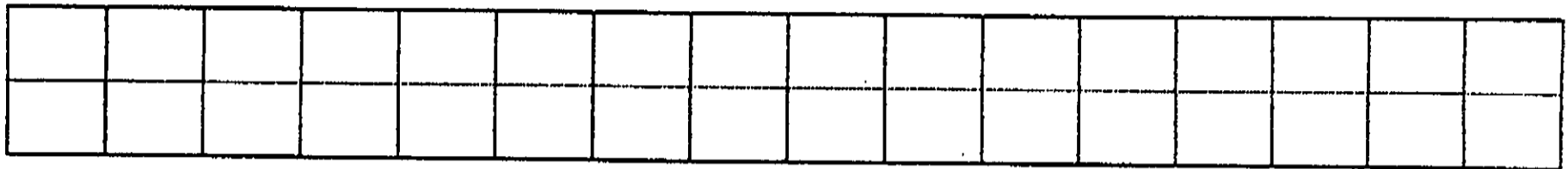
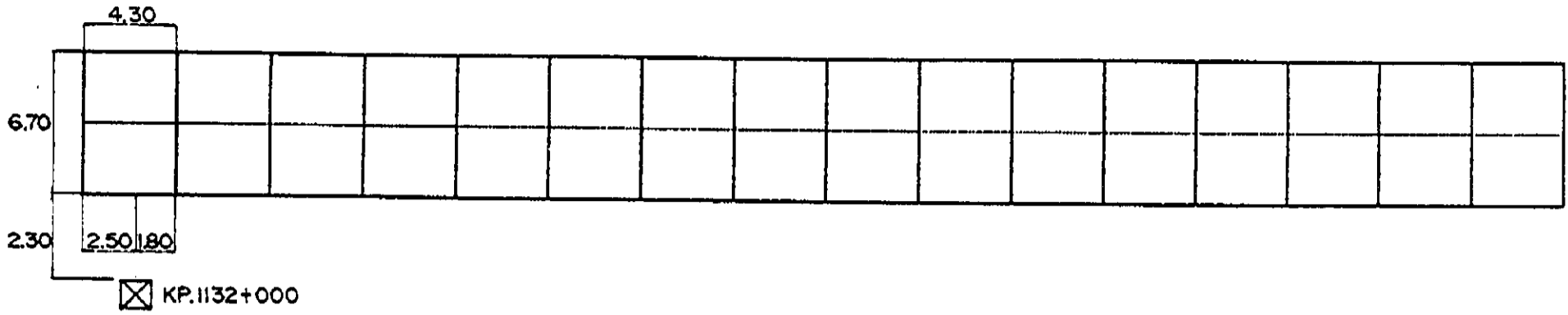

INVENTORY OF PAVEMENT SURFACE CONDITION

Km. 1132 + 000

Date: 11-15-95

Sheet No: 2/2

	Sc	Sc	Sc	Sc	Sc	Sc	Sc				Sc	Sc		Sc	Sc	Sc

Sc	Sc	Sc	Sc													

-	-			-	-	-	-	-	-	-	-	-				Sc

	Sc	Sc	Sc	Sc	Sc	Sc	Sc	Sc	Sc	Sc		Sc	Sc		Sc	Sc

-	-	-									Sc	Sc	Sc	Sc	Sc	Sc	Sc

Sc	Sc	Sc	Sc	Sc	Sc	Sc	-	Sc								-

Sc	Sc	Sc	Sc	Sc	Sc												

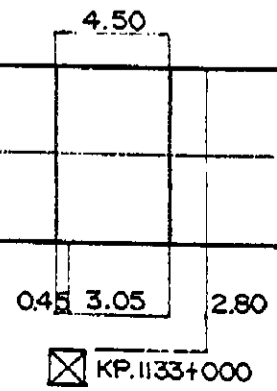

INVENTORY OF PAVEMENT SURFACE CONDITION

Km. 1133+000

Date: 11-15-95

Sheet No: 2/2

4.50

oh

6.70

1.00 3.50

3.10

☒ KP1134+000

INVENTORY OF PAVEMENT SURFACE CONDITION

Km. 1134 + 000

Date: 11 - 15 - 95

Sheet No: 2 / 3

— Surigao Del Norte /
Surigao City Bdry.

			P ₀	P ₀											

			P ₀	P ₀	P ₀	P ₀	P ₀	P ₀	P ₀	P ₀		P ₀	P ₀	P ₀	P ₀

P ₀		P ₀	P ₀	P ₀	P ₀	P ₀	P ₀	P ₀	P ₀						

P ₀	P ₀	P ₀	P ₀									P ₀	P ₀	P ₀	P ₀

INVENTORY OF PAVEMENT SURFACE CONDITION

Date : 11-15-95

Sheet No : 1/2

Km. 1135 +000

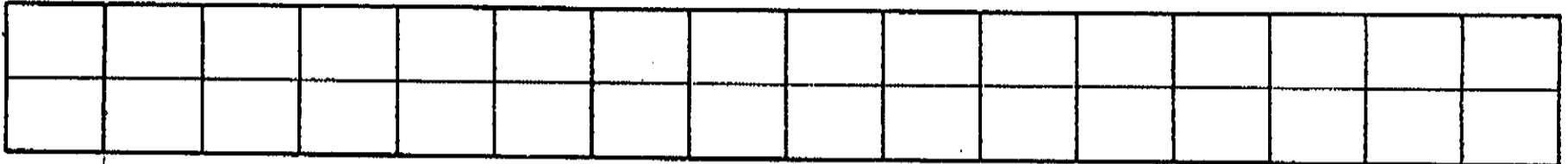
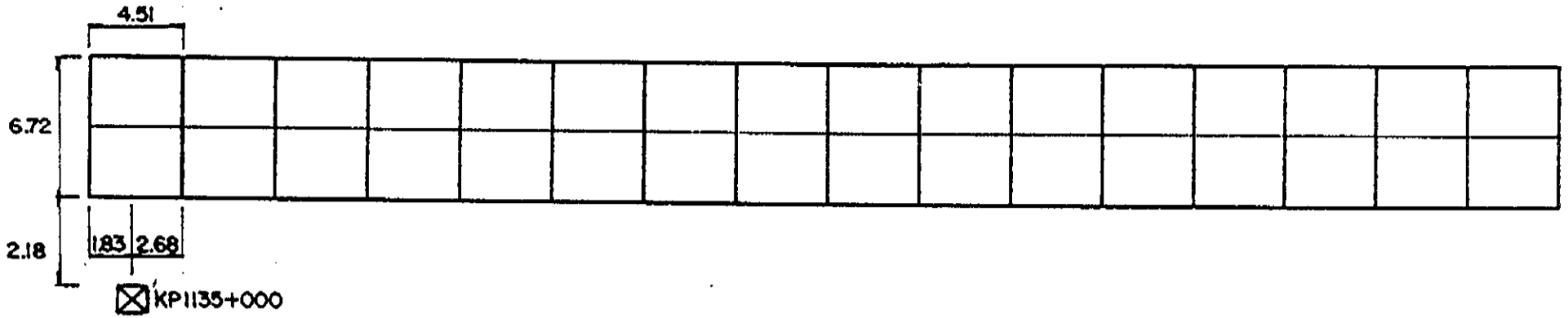

— South bound lane utilized as stockpile area for the on-going construction of slope protection.



End of stockpile area

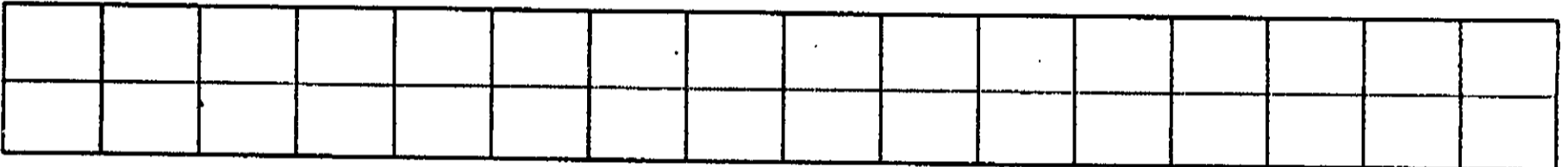

— Start of conc. pavement shoulder, (w=2.00)

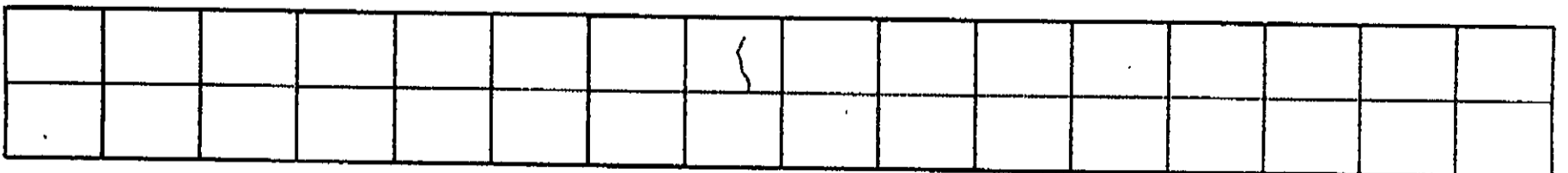
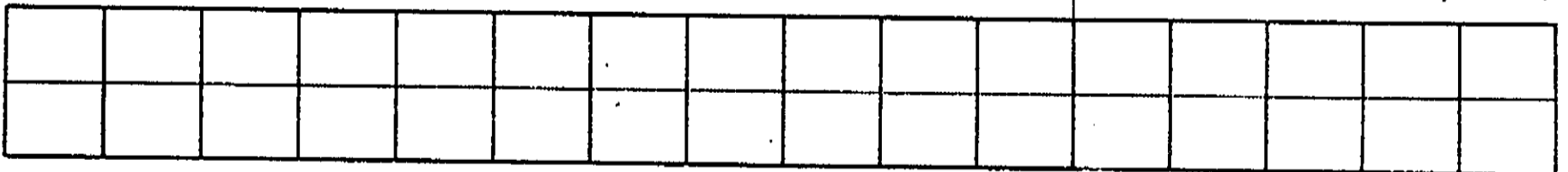

End of conc. pavt. shoulder

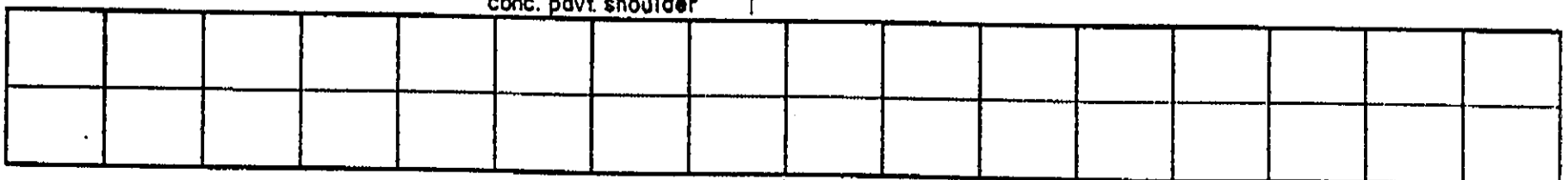

INVENTORY OF PAVEMENT SURFACE CONDITION

Date : 11-15-95

Sheet No : 2/2

Km. 1135+000

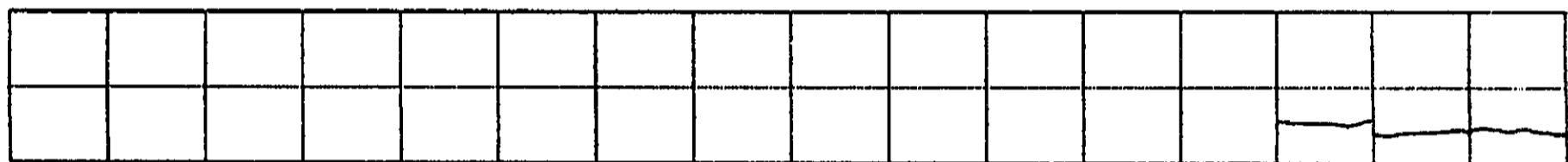
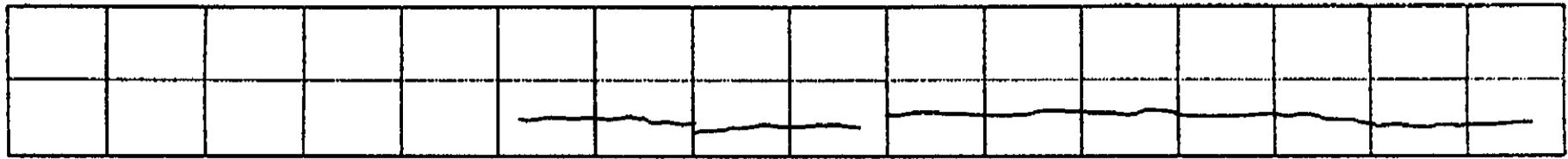

Open crack

1.30
Start of conc. pavement
shoulder, (w=2.00)

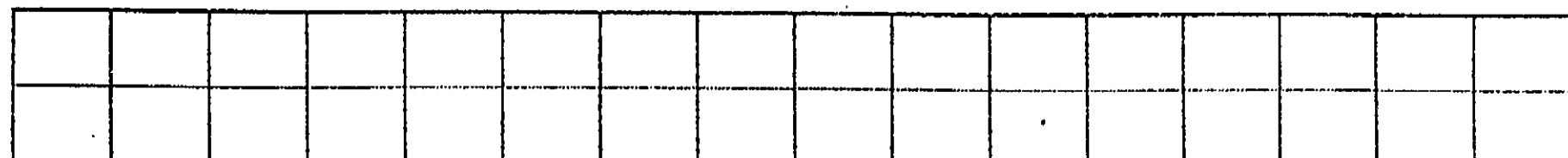
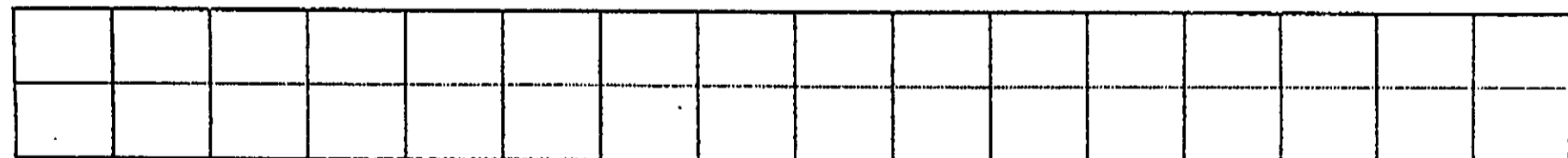
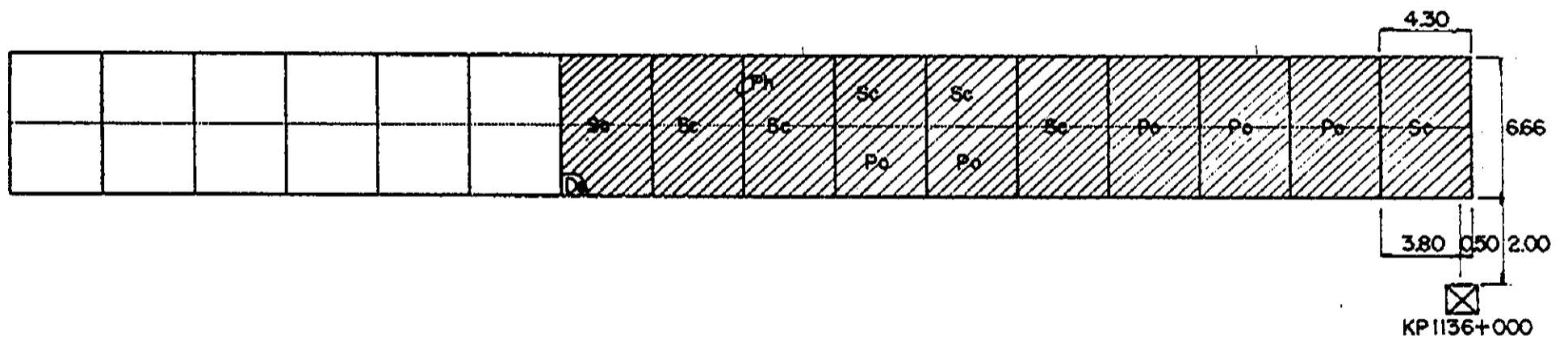

INVENTORY OF PAVEMENT SURFACE CONDITION

Km. 1136+000

Date: 11-15-95

Sheet No: 1/2

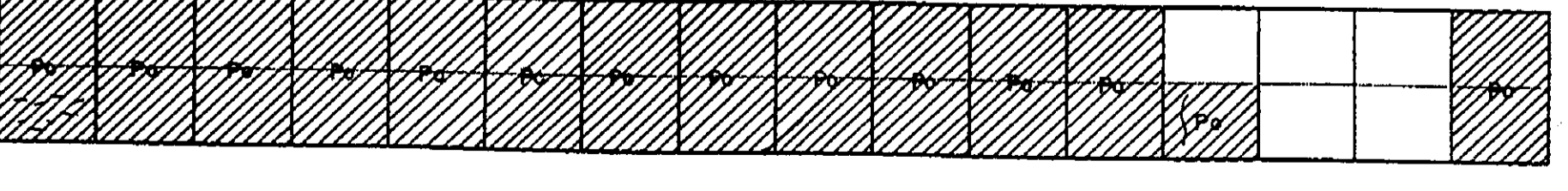
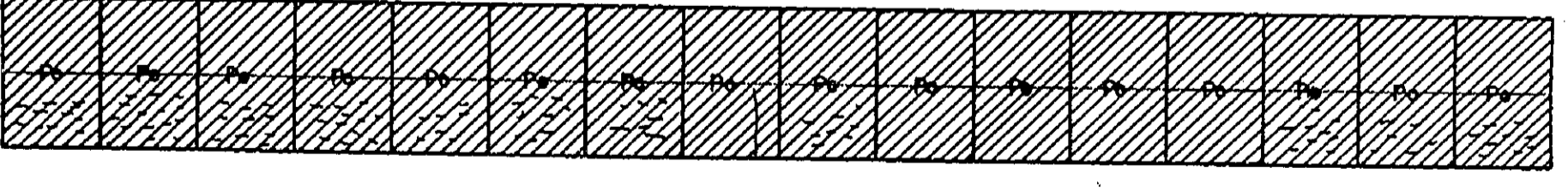
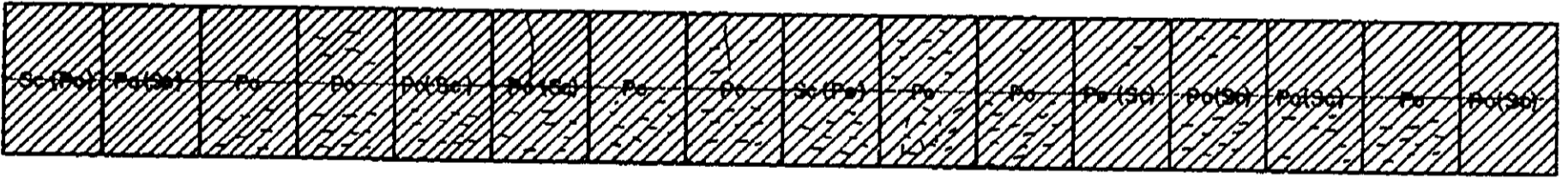
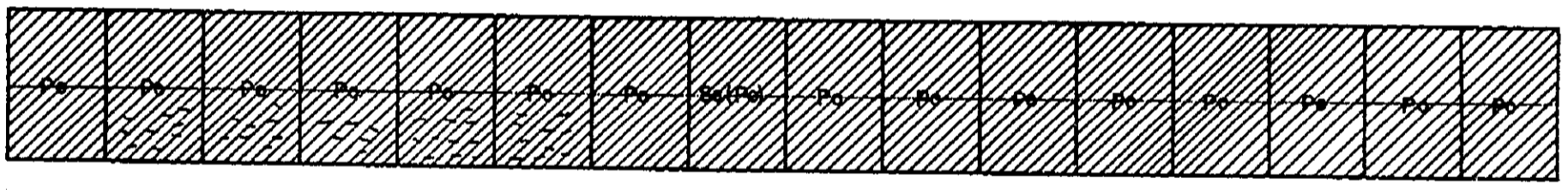
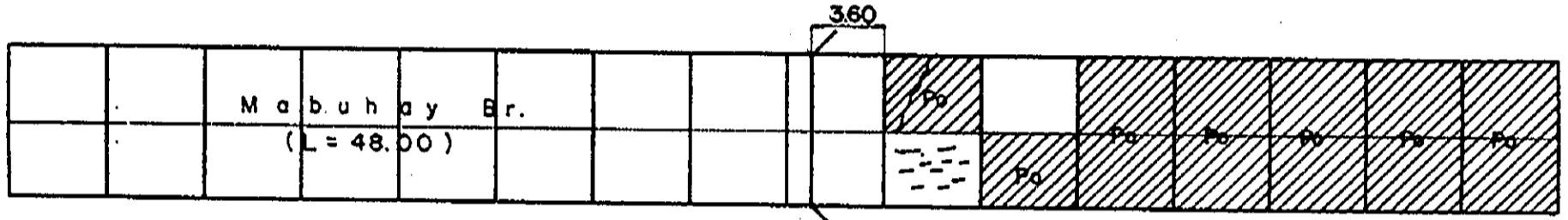
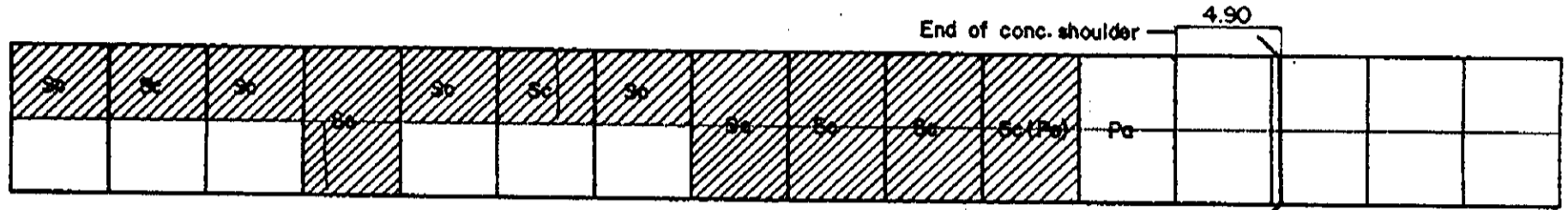
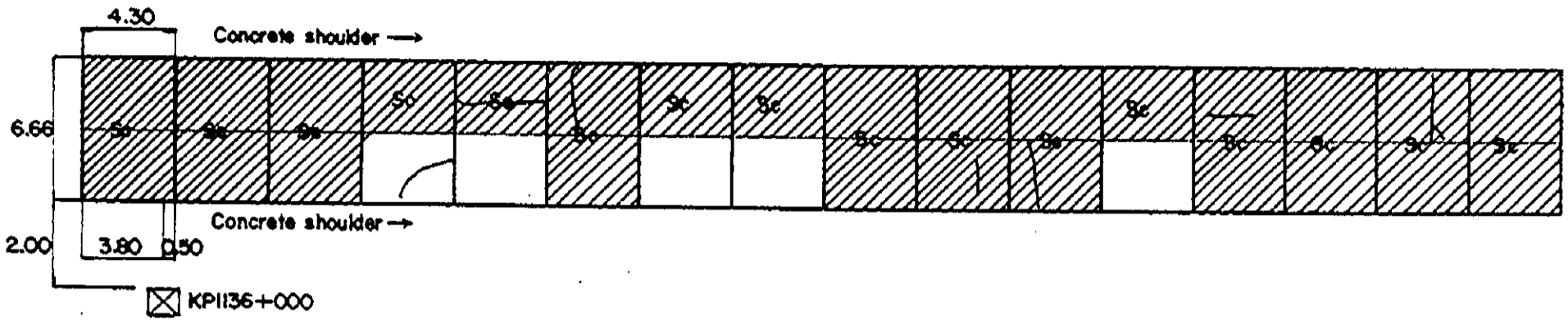

INVENTORY OF PAVEMENT SURFACE CONDITION

Km. 1136+000

Date : 11-15-95

Sheet No : 2/2

	P ₀	P ₀	P ₀	P ₀	P ₀	P ₀	P ₀	P ₀	P ₀	P ₀	P ₀	P ₀	P ₀	P ₀	P ₀ (Sc)

P ₀	P ₀	P ₀	P ₀	P ₀	P ₀	P ₀	P ₀	P ₀	P ₀	P ₀	P ₀	P ₀	P ₀	P ₀	P ₀

									h					
P ₀	P ₀	P ₀	P ₀	P ₀	P ₀	P ₀	P ₀	P ₀	P ₀	P ₀	P ₀	P ₀	P ₀	P ₀

									P ₀	P ₀	P ₀	P ₀	P ₀	P ₀	P ₀

P ₀	P ₀	P ₀	P ₀	P ₀	P ₀	P ₀	P ₀	P ₀	P ₀	P ₀	P ₀	P ₀	P ₀	P ₀	P ₀

P ₀	P ₀	P ₀	P ₀	P ₀	P ₀	P ₀	P ₀	P ₀	P ₀	P ₀	P ₀	P ₀	P ₀	P ₀	P ₀

P ₀	P ₀	P ₀	P ₀	P ₀	P ₀	P ₀	P ₀	P ₀	P ₀	P ₀	P ₀	P ₀	P ₀	P ₀	P ₀
														4.20	3.35
														4.25	2.83
														148.272	2.83

INVENTORY OF PAVEMENT SURFACE CONDITION

Km. 1137+000

Date: 11-15-95

Sheet No: 2/2

4.53
3.35
3.73
2.052.48
3.12

INVENTORY OF PAVEMENT SURFACE CONDITION

Km. 1138+000

Date: 11-15-95

Sheet No: 2/2

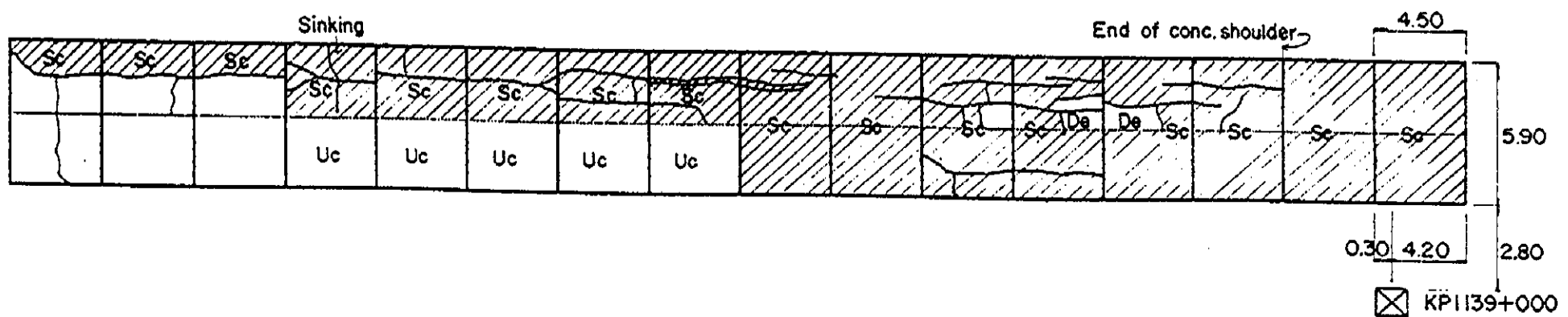
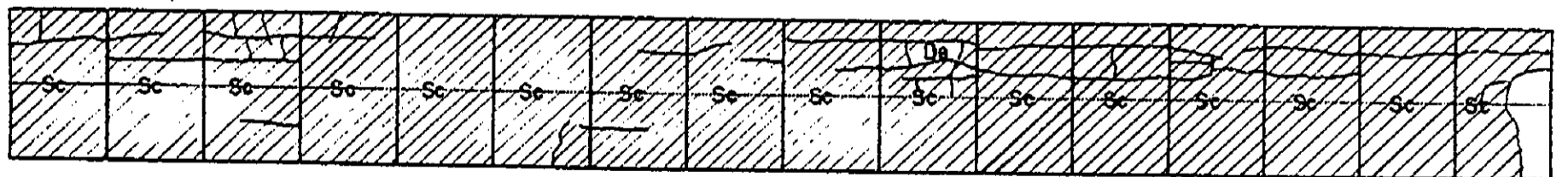
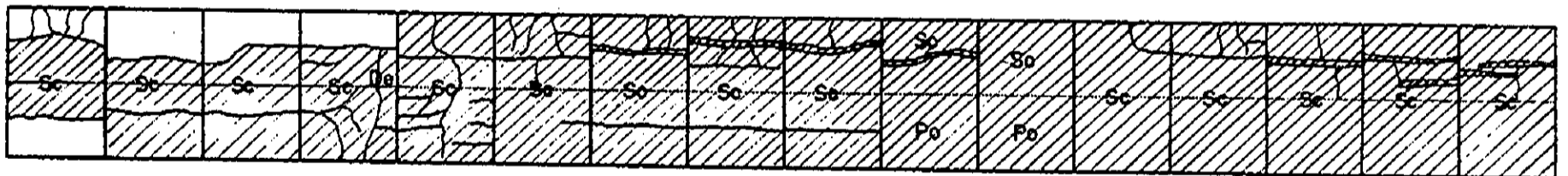
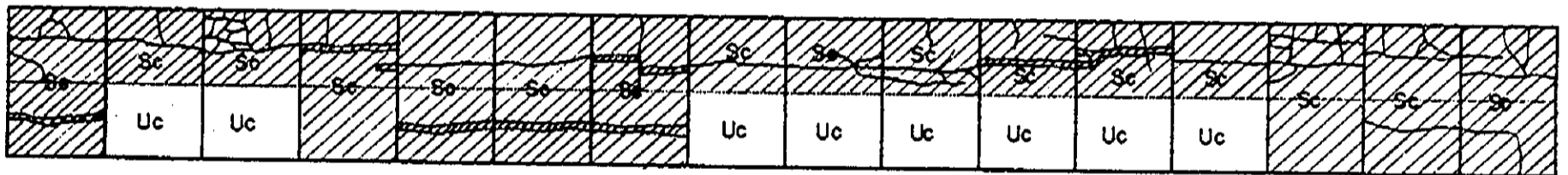
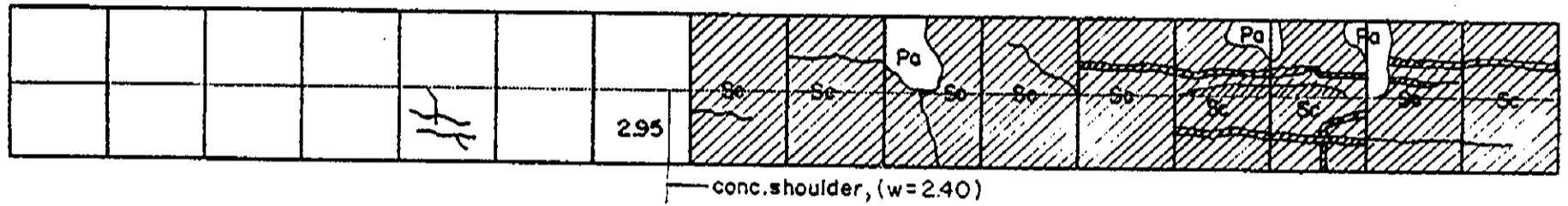

INVENTORY OF PAVEMENT SURFACE CONDITION

Km. 1139+000

Date: 11-16-95

Sheet No: 1/2

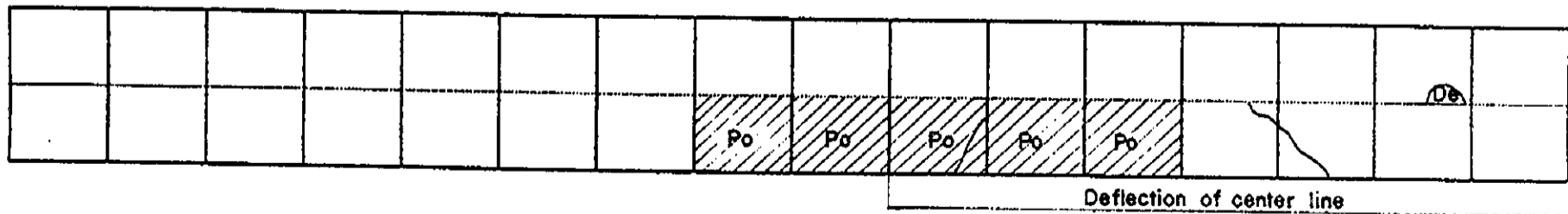
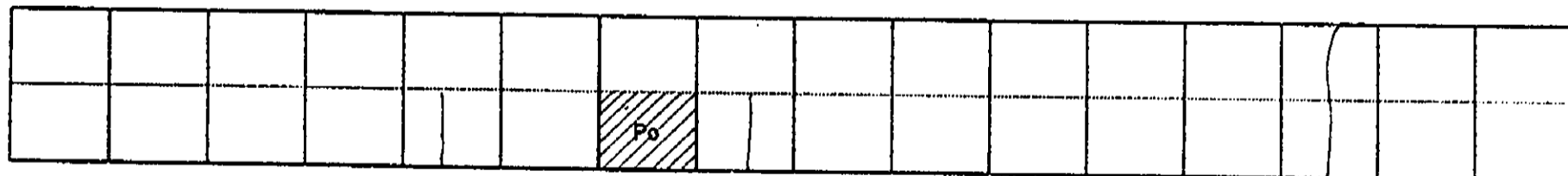
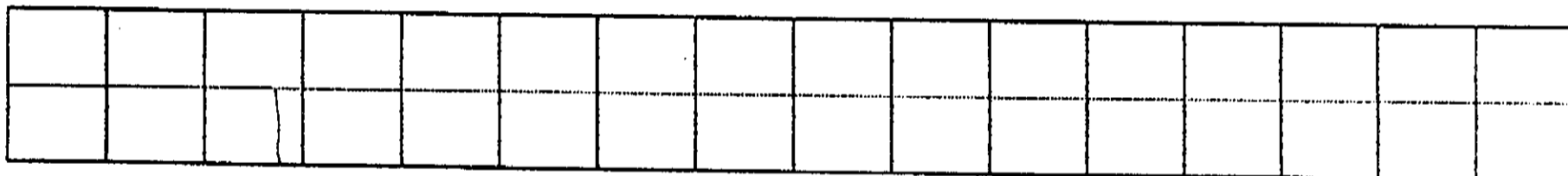
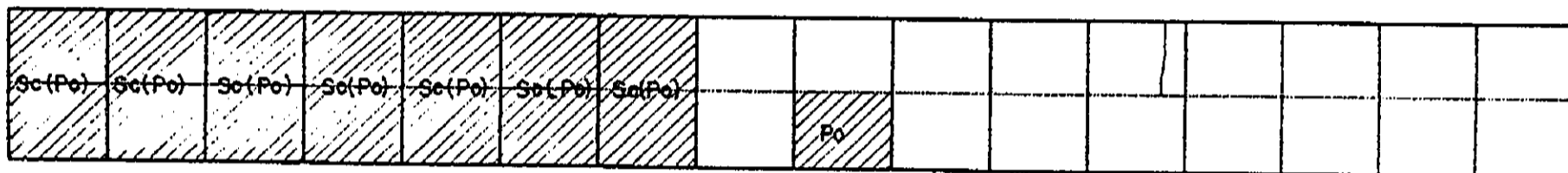
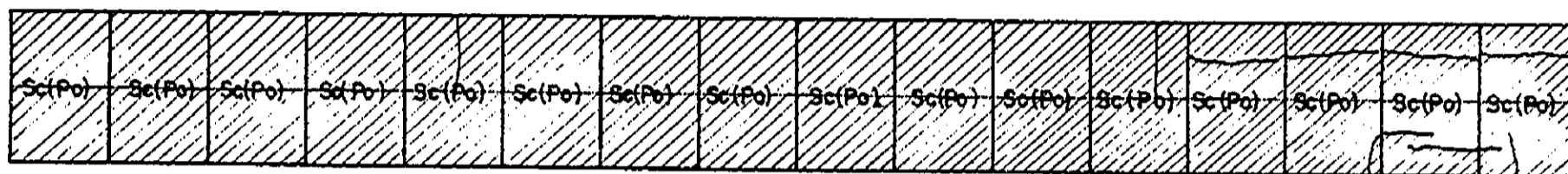
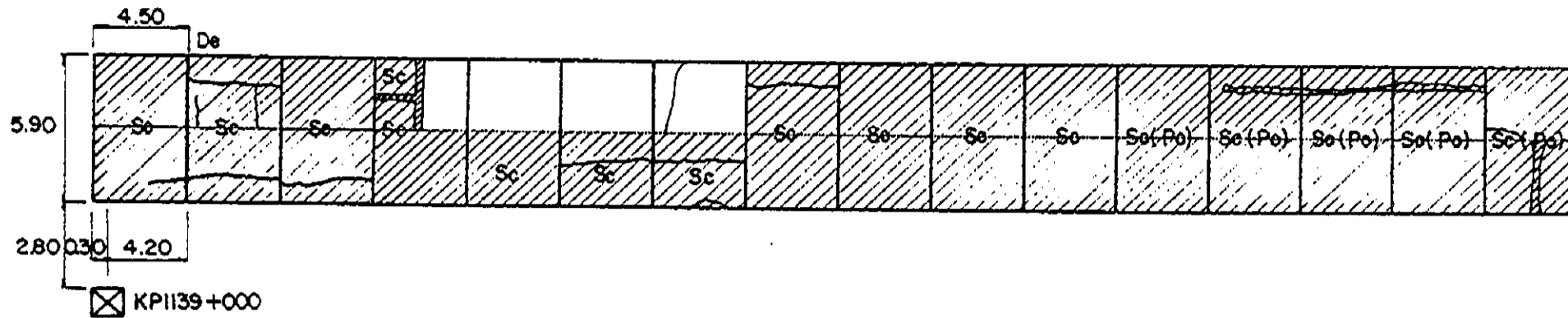

Deflection of center line

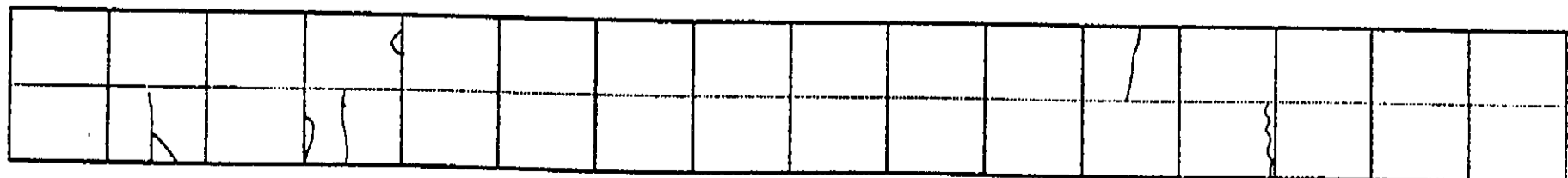

INVENTORY OF PAVEMENT SURFACE CONDITION

Km. 1139+000

Date: 11-16-95

Sheet No: 2/2

								Po	Po											Po

						Po						Po									

			Sc	Sc	Sc																

								Sc	Sc												

4.80

6.76

0.40 4.40 3.30

☒ KP1140+000

INVENTORY OF PAVEMENT SURFACE CONDITION

Date : 11-16-95

Km. 1140+000

Sheet No : 1/2

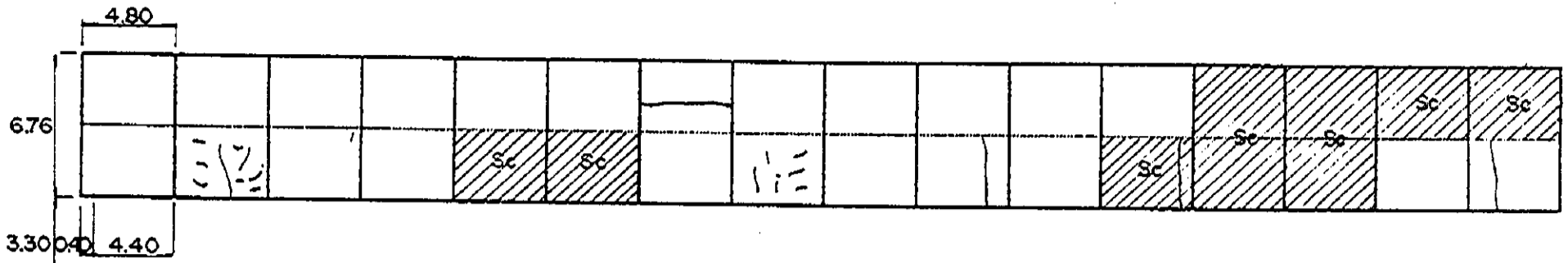

☒ KP.1140+000

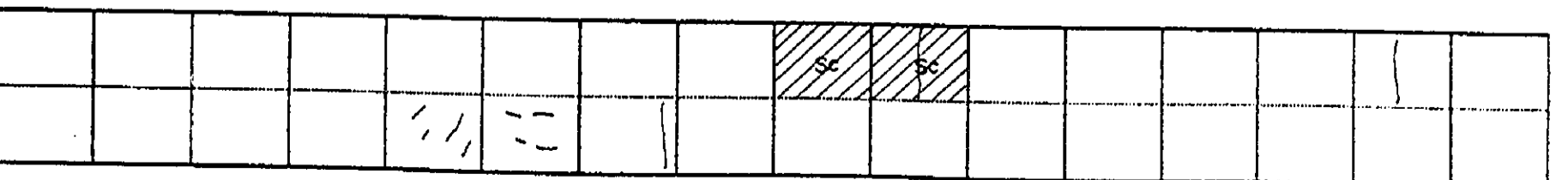
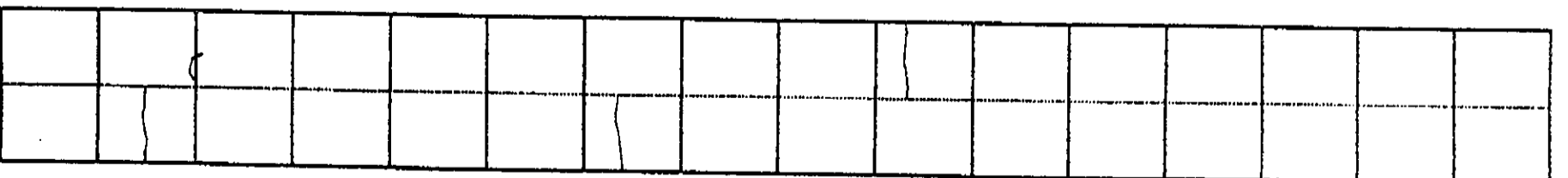
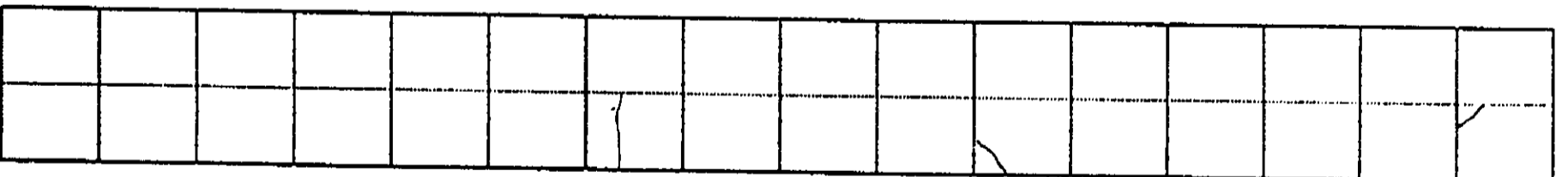
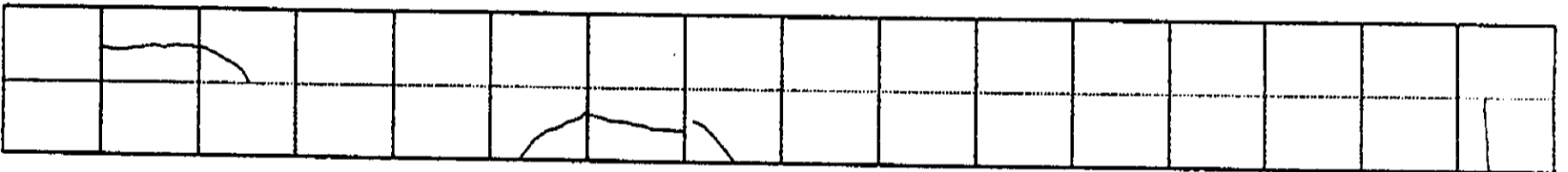
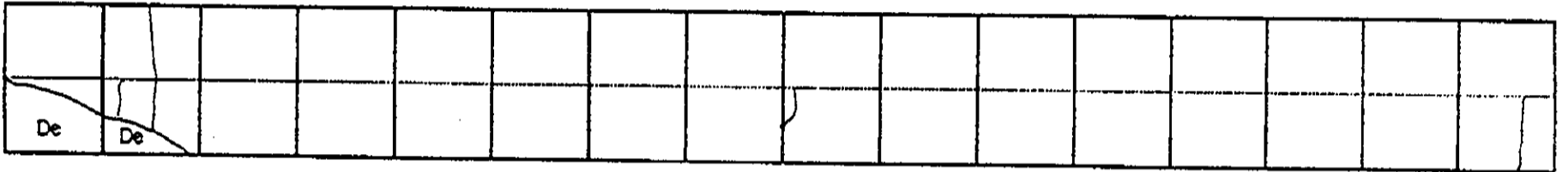
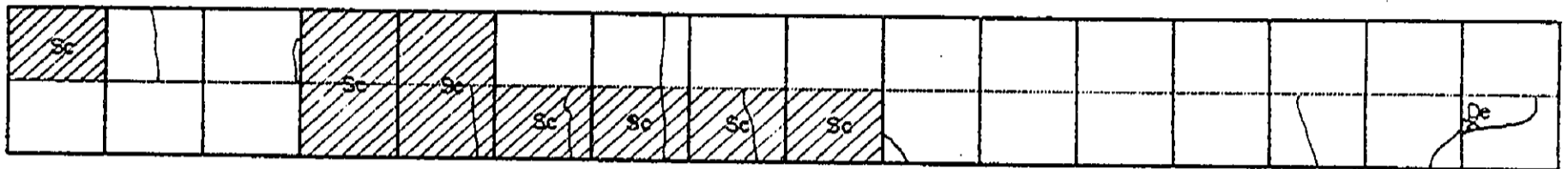

INVENTORY OF PAVEMENT SURFACE CONDITION

Km. 1140+000

Date: 11-16-95

Sheet No: 2/2

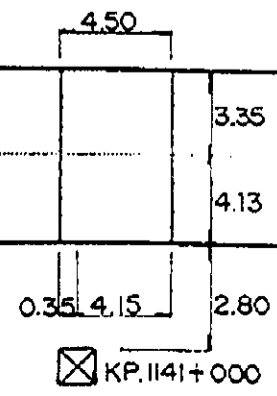

☒ KP.1141+000

INVENTORY OF PAVEMENT SURFACE CONDITION

Date: 11-16-95

Km. 1141+000

Sheet No: 2/2

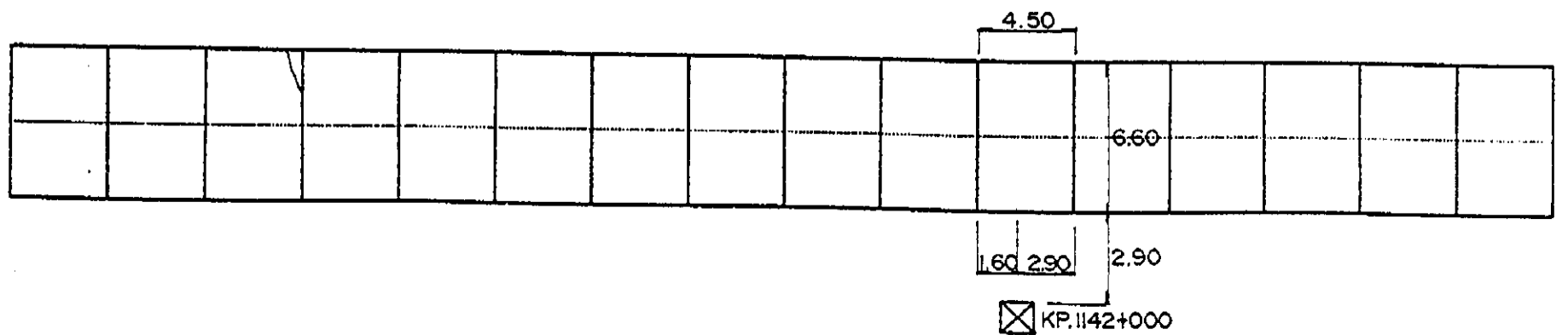
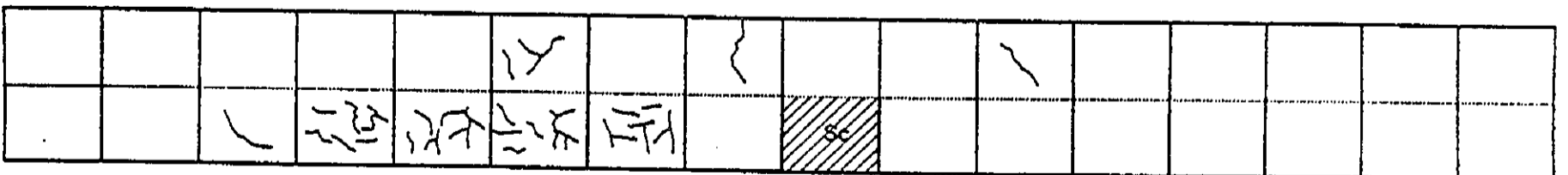
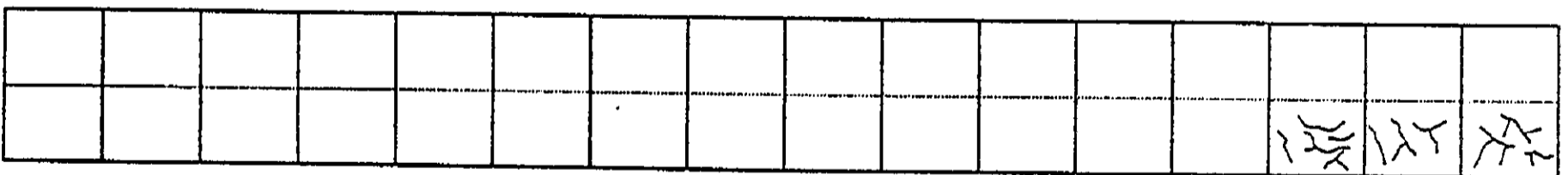
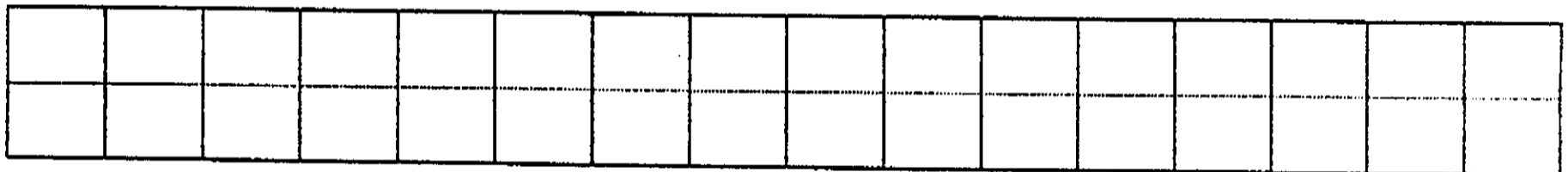
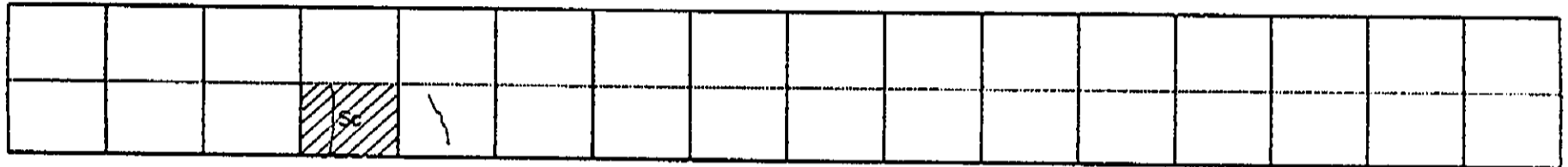
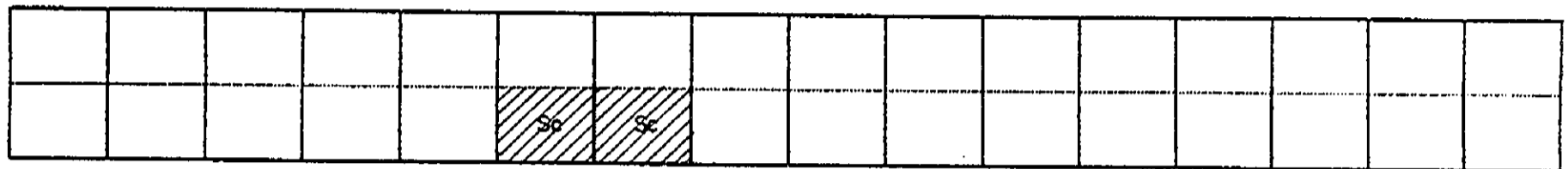
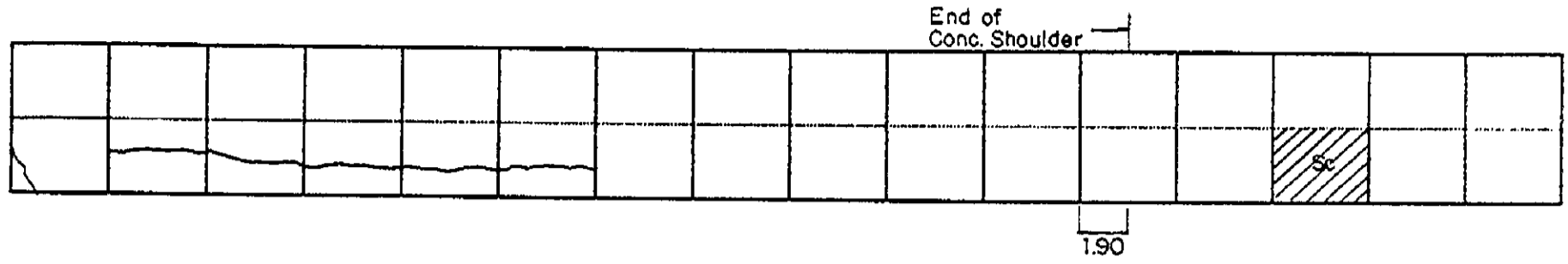

INVENTORY OF PAVEMENT SURFACE CONDITION

Km. 1142+000

Date : 11-16-95

Sheet No : 1/2

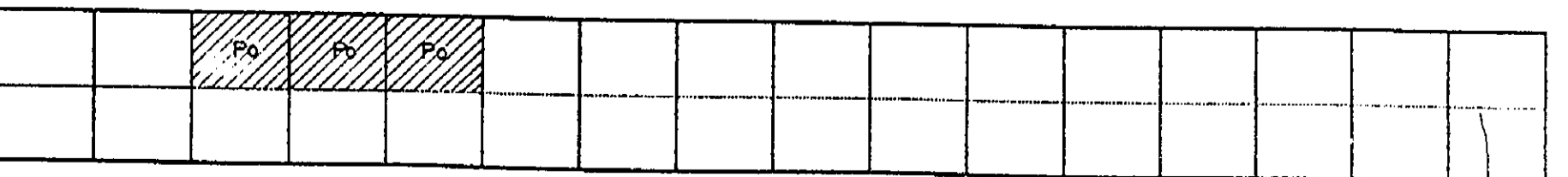
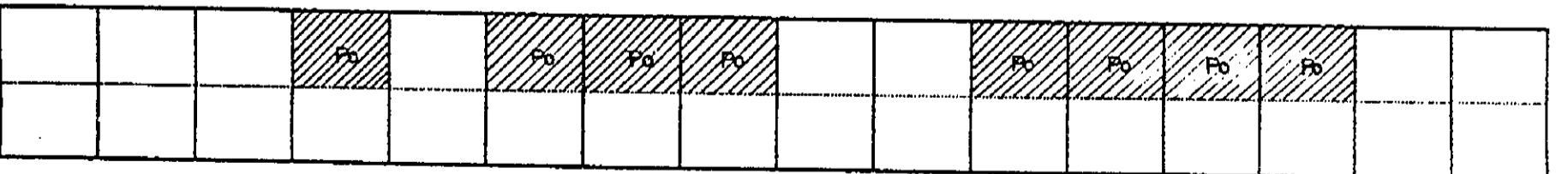
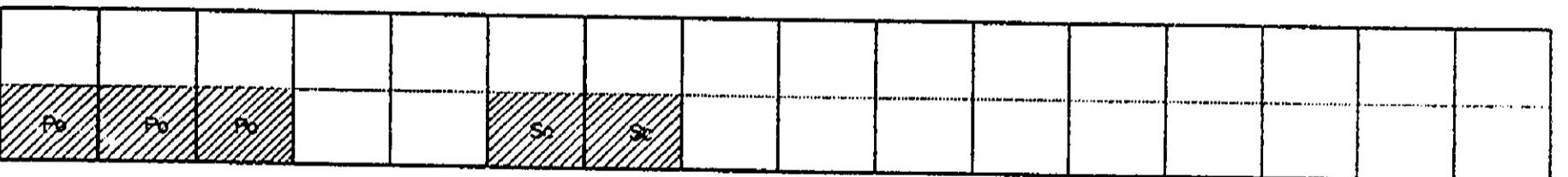
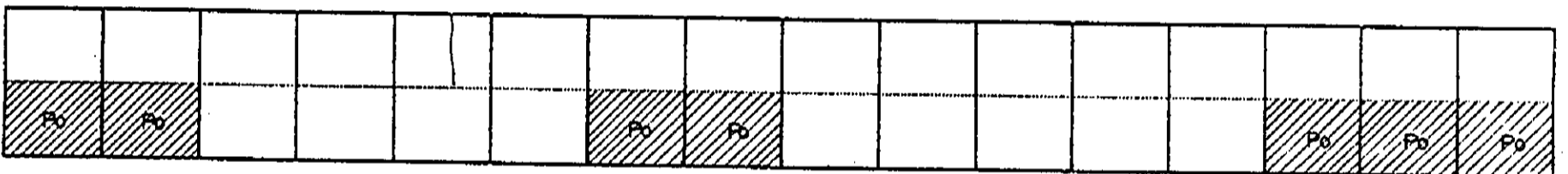
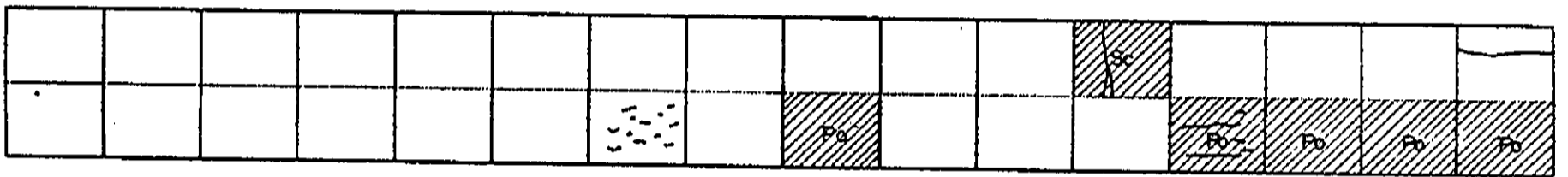
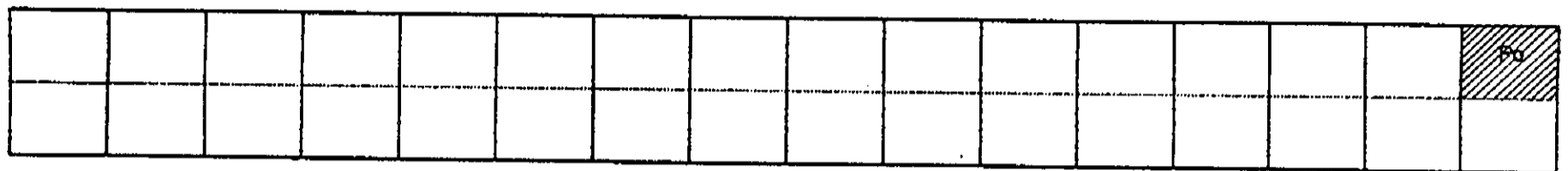
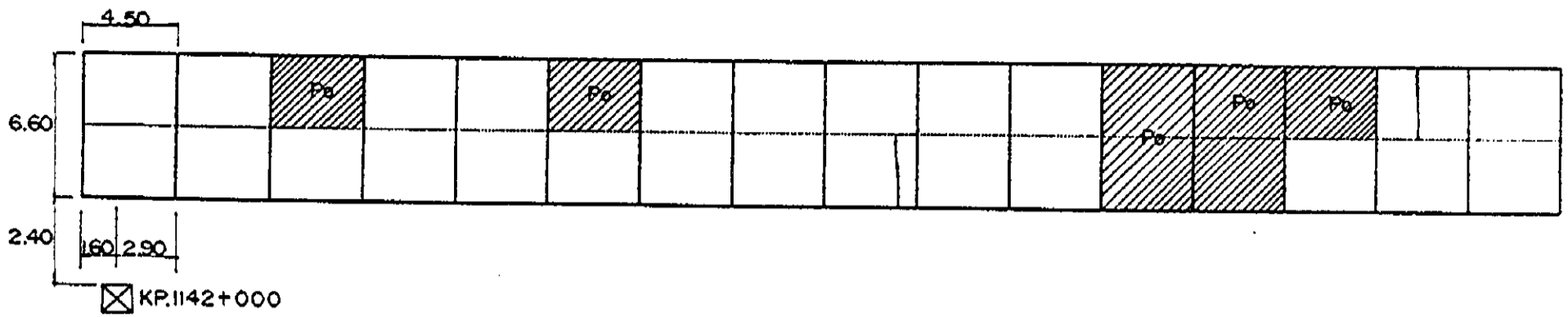

INVENTORY OF PAVEMENT SURFACE CONDITION

Km. 1142+000

Date: 11-16-95

Sheet No: 2/2

					Po					Sc	Sc	Sc						Po	

	Sc		Po (Sc)	Sc						c									Sc

Sc			Sc		Sc	Sc	Sc	Sc	Sc	Sc	Sc	Sc	Sc	Sc	Sc	Sc	Sc	Sc	Sc

Sc	Sc	Sc	Sc	Sc	Sc	Sc	Sc	Sc	Sc	Sc	Sc	Sc	Sc						

					Sc	Sc	Sc											Po	Po	Po

	Po	Po	Po	Po	Po	Po	Po	Po	Po	Po									

4.44
7.24
2.40 2.04 2.75

INVENTORY OF PAVEMENT SURFACE CONDITION

Km. 1143+000

Date: 11-16-95

Sheet No: 1/2

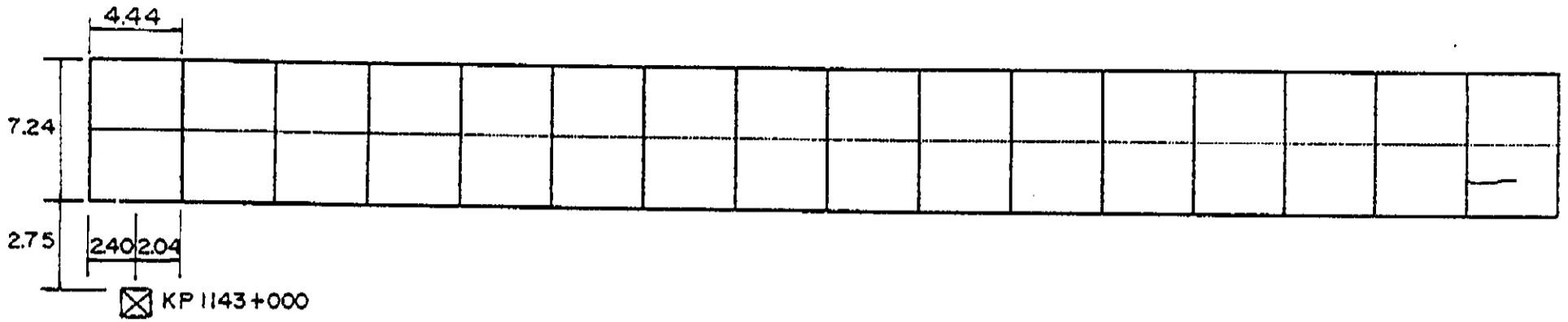

Sc Sc Sc

INVENTORY OF PAVEMENT SURFACE CONDITION

Km. 1143+000

Date: 11-16-95

Sheet No: 2/2

Sc	Sc	Sc							Sc						

									Sc					Sc	Sc

4.53
6.76
0.44 4.09 3.65
☒ KP 1144+000

INVENTORY OF PAVEMENT SURFACE CONDITION

Km. 1144 + 000

Date: 11 - 16 - 95

Sheet No: 2/2

							S								

													S		

S															Ph

		Ph											Ph		

					S									4.50	
															6.70
														1403.10	3.20

X KP 1145 + 000

INVENTORY OF PAVEMENT SURFACE CONDITION

Date: 11 - 17 - 95

Sheet No: 1/2

Km. 1145 + 000

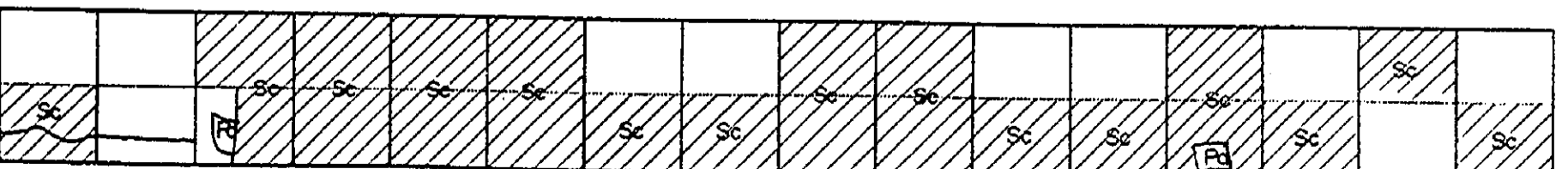
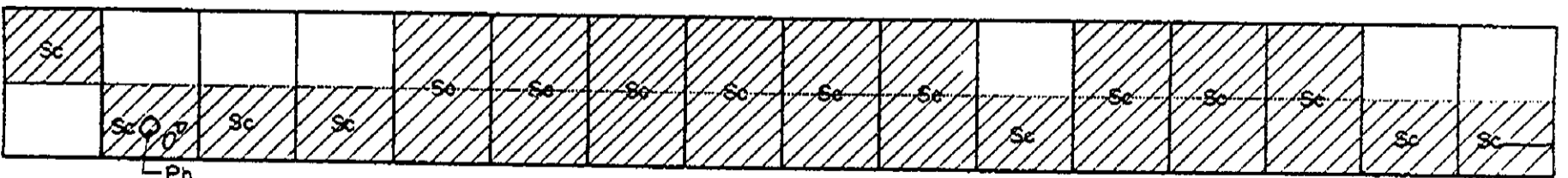
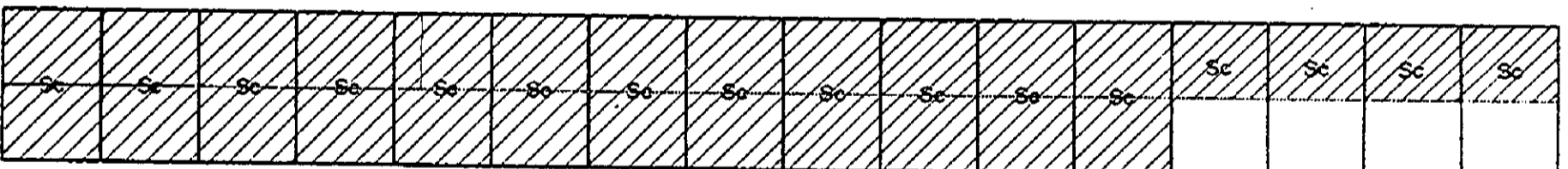
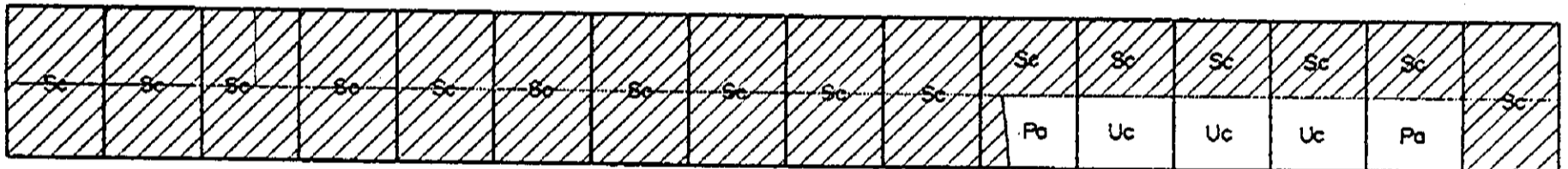
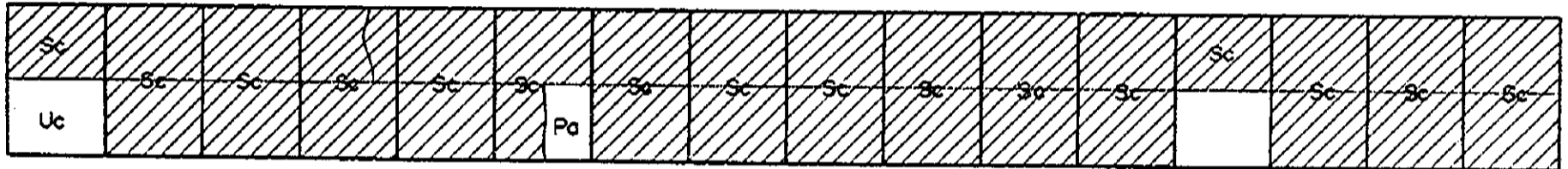
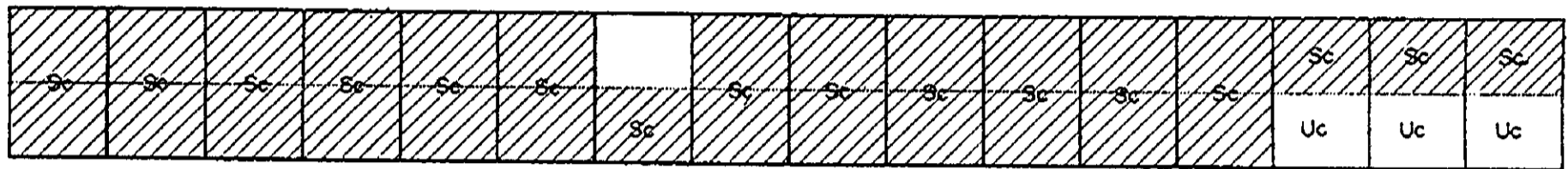
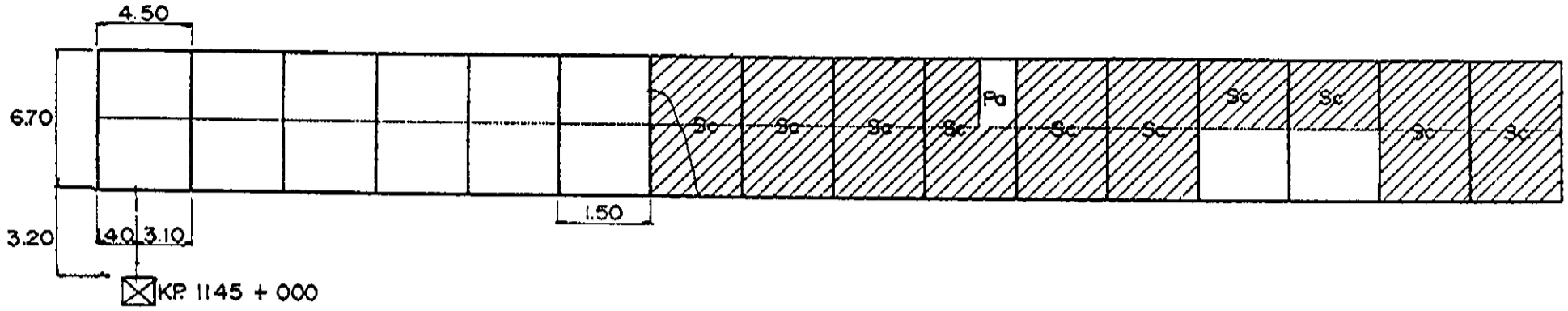

INVENTORY OF PAVEMENT SURFACE CONDITION

Km. 1145 + 000

Date: 11 - 17 - 95

Sheet No: 2/2

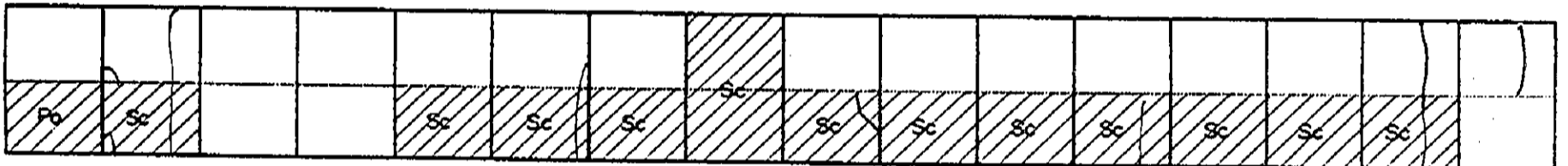
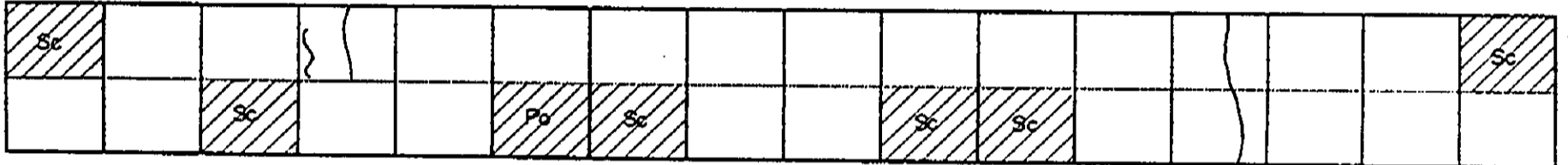
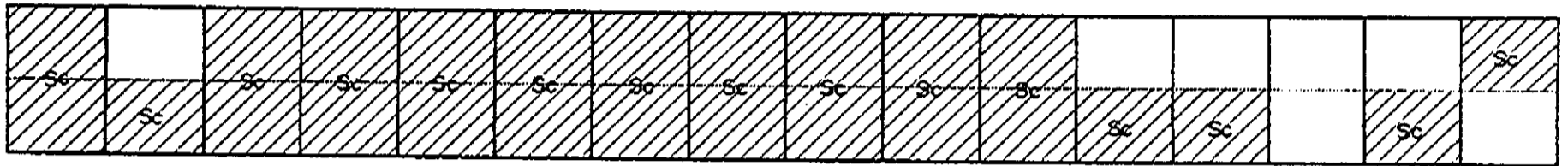
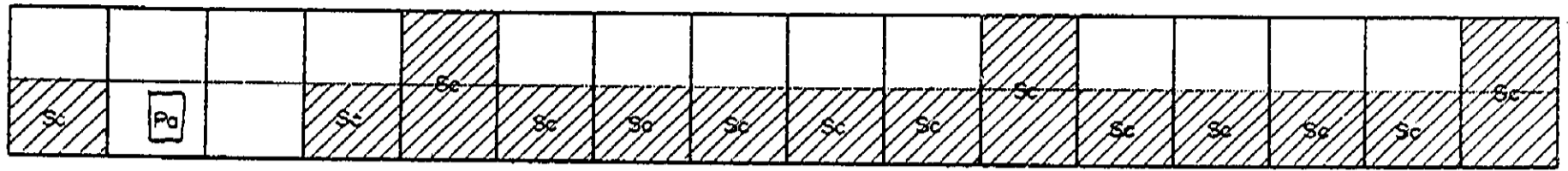

— Conc. Shoulder, w = 2.02 (Both Sides)

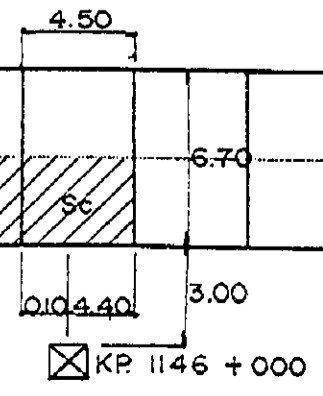
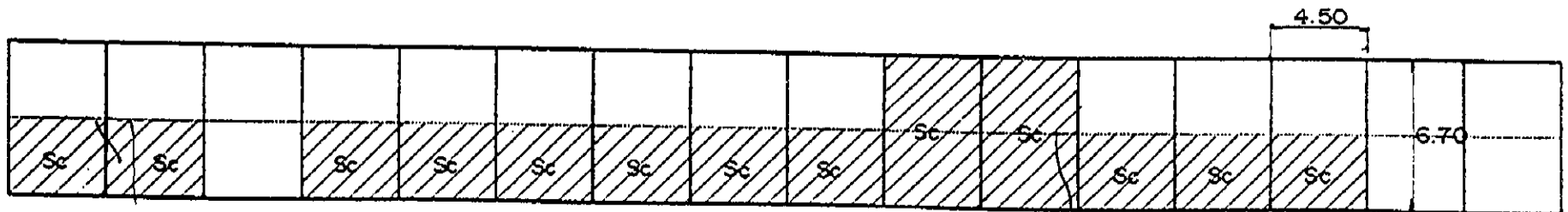
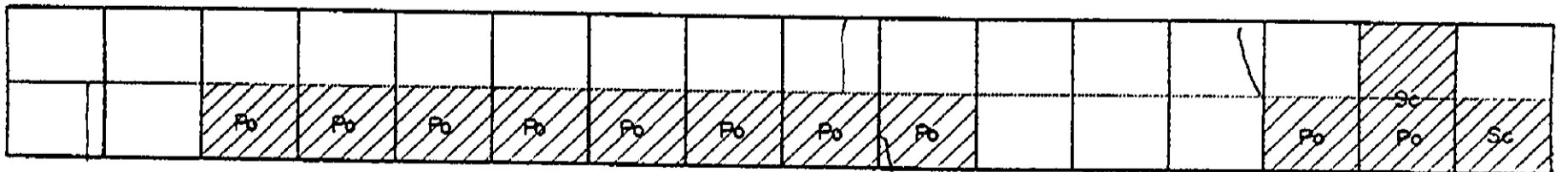
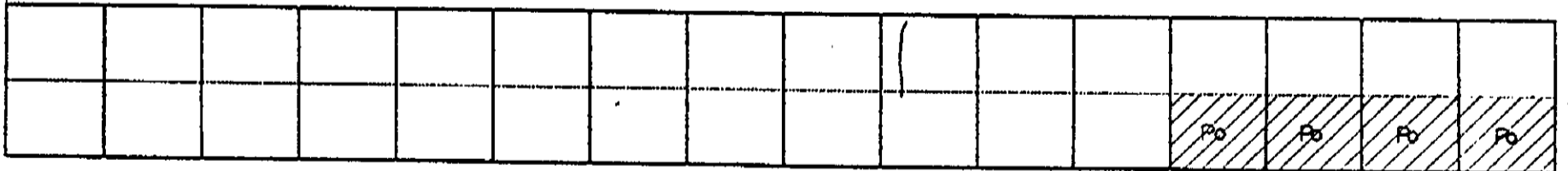

INVENTORY OF PAVEMENT SURFACE CONDITION

Km. 1146 + 000

Date: 11 - 17 - 95

Sheet No: 1/2

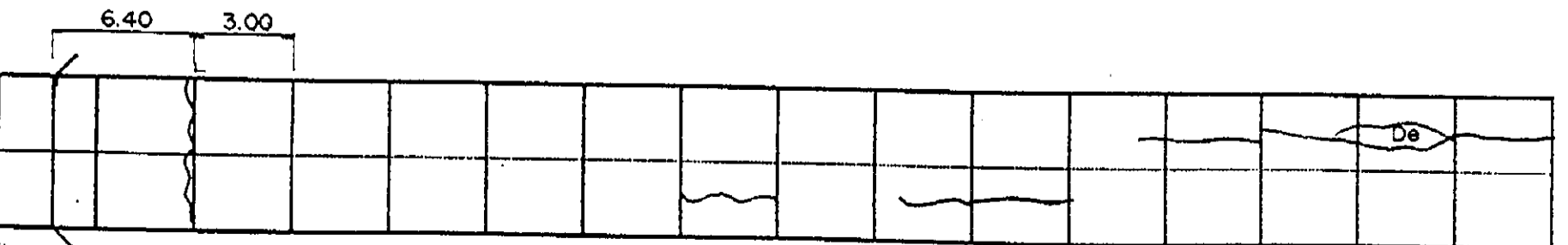
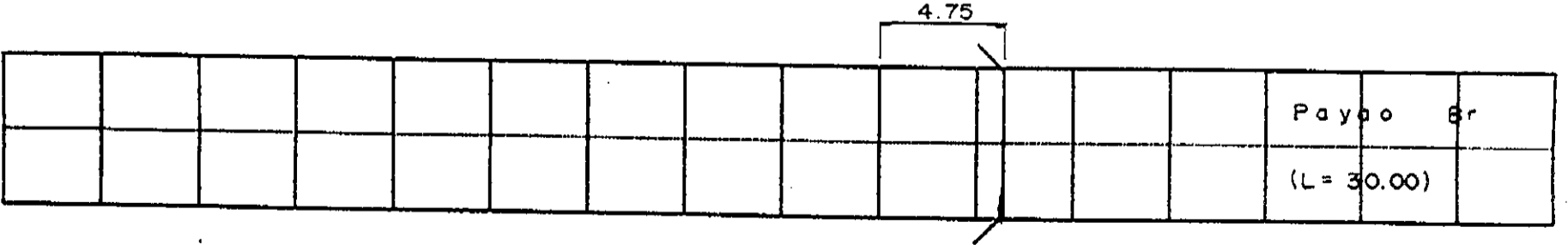
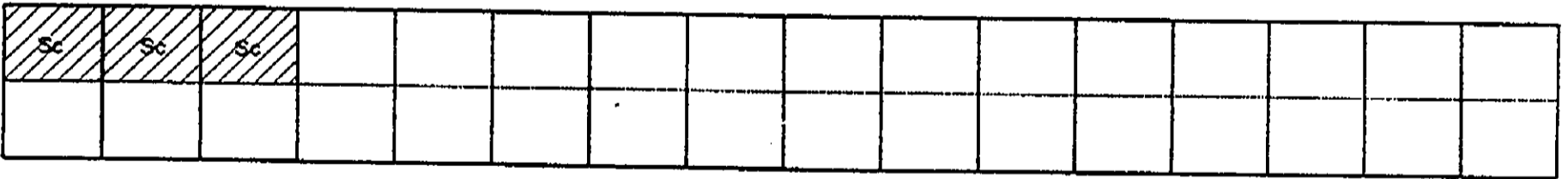
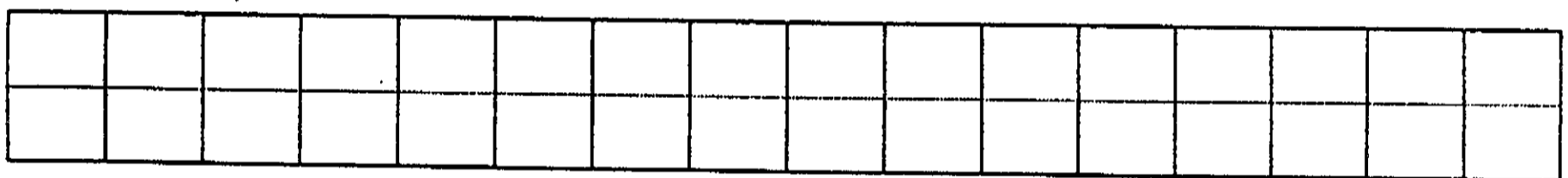
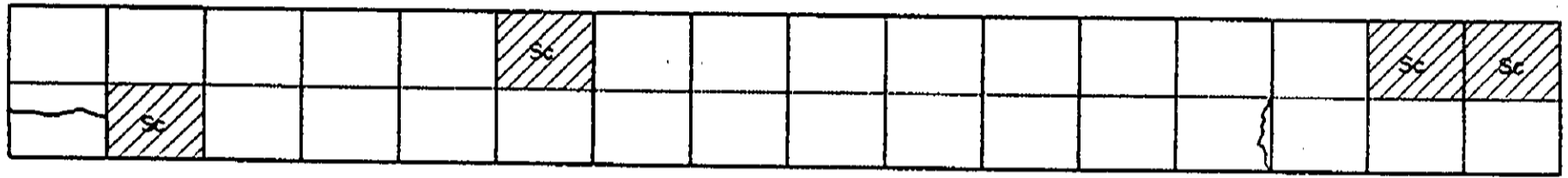
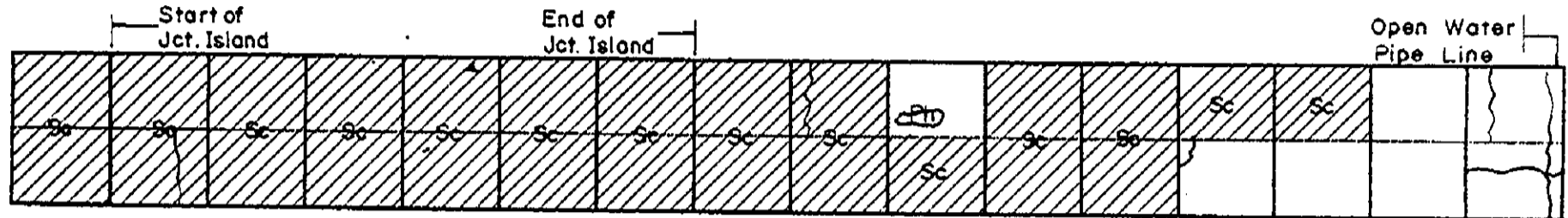
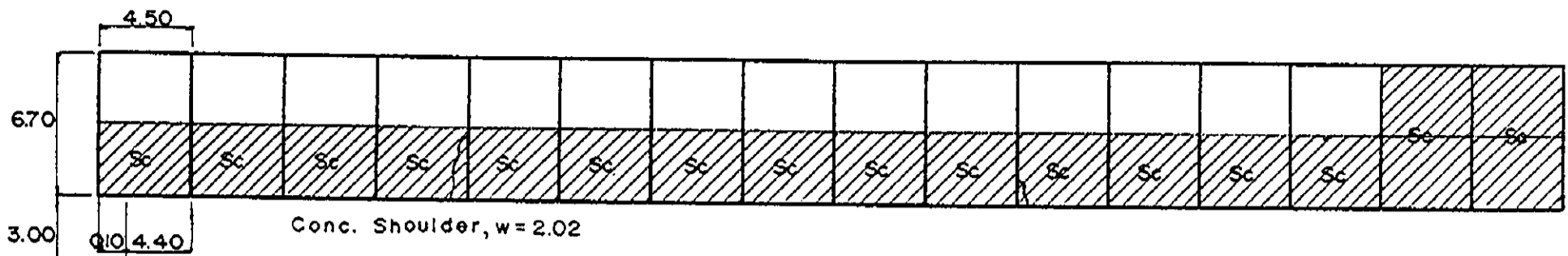

INVENTORY OF PAVEMENT SURFACE CONDITION

Km. 1146 + 000

Date: 11 - 17 - 95

Sheet No: 2/2

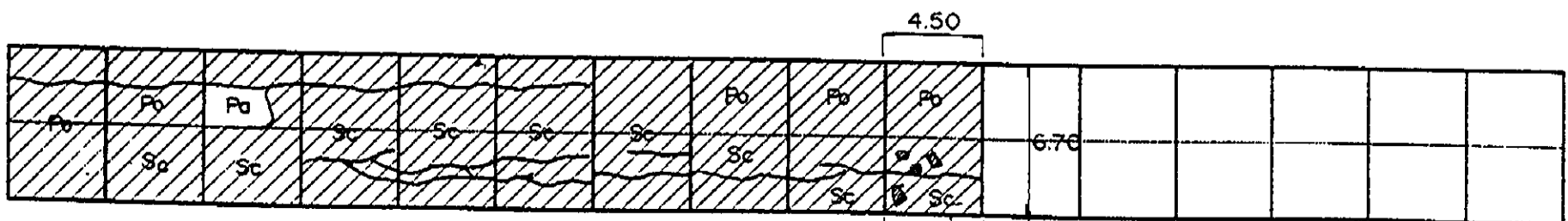
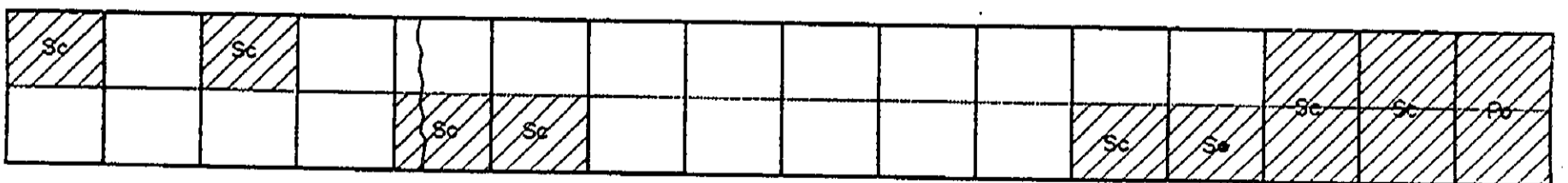
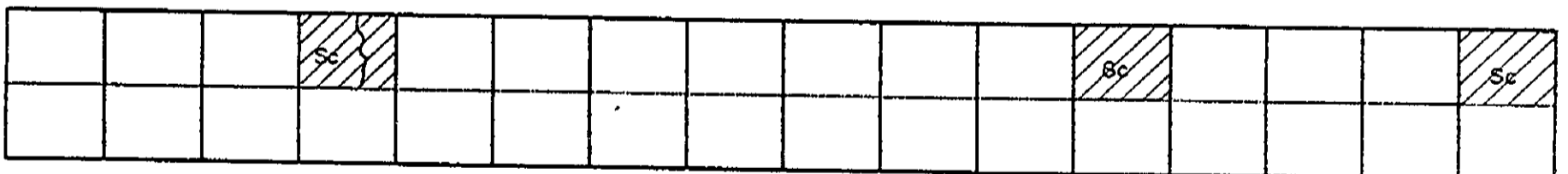
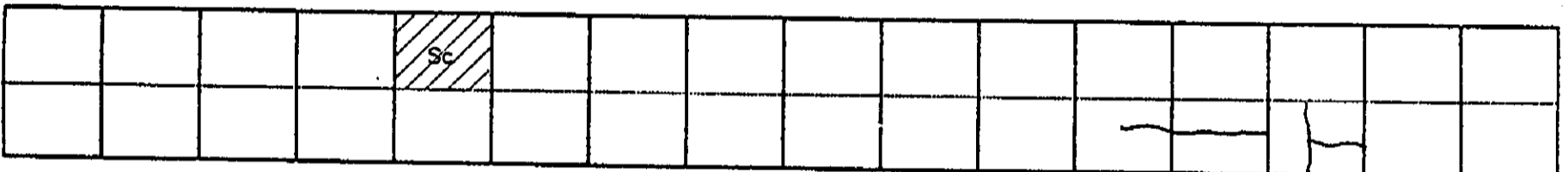
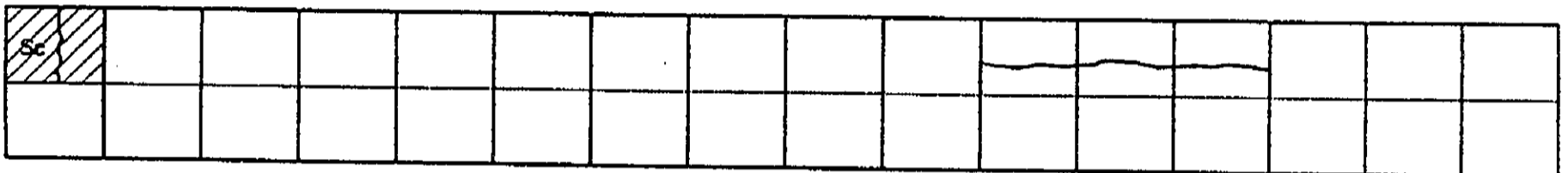
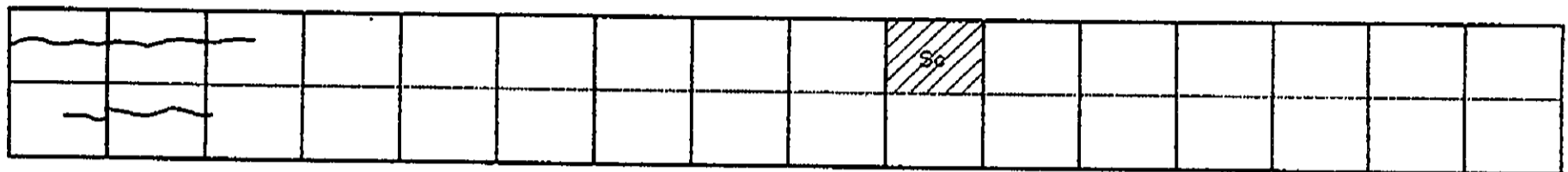
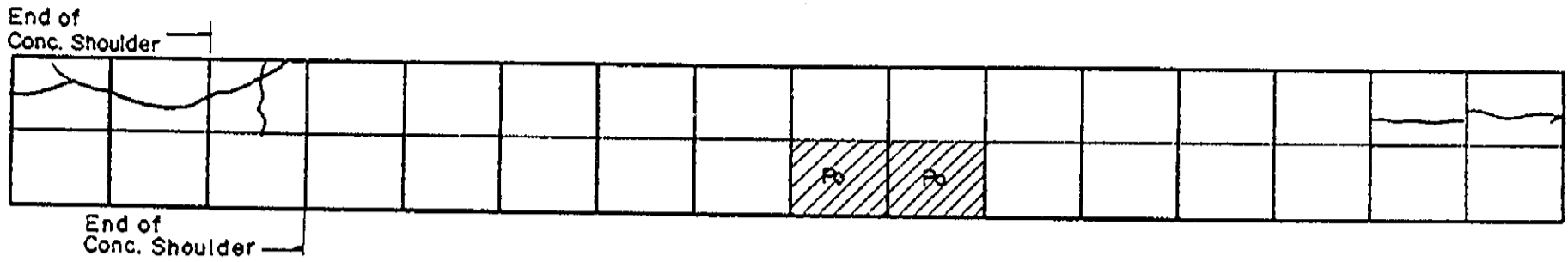

4.50
6.76
4.20 0.30 2.80

☒ KP 1147 + 000

INVENTORY OF PAVEMENT SURFACE CONDITION

Date: 11 - 17 - 95

Sheet No: 1/3

Km. 1147 + 000

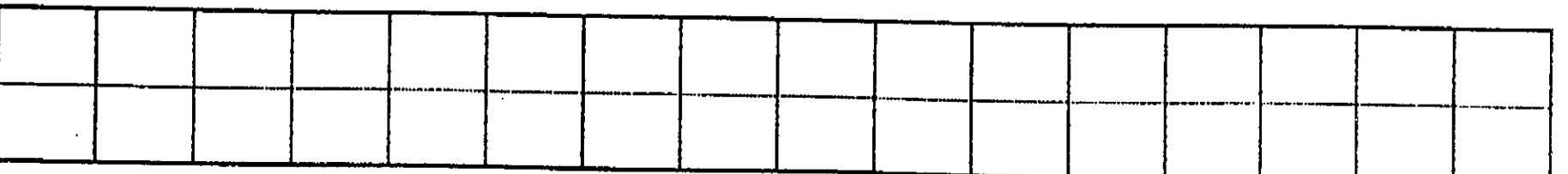
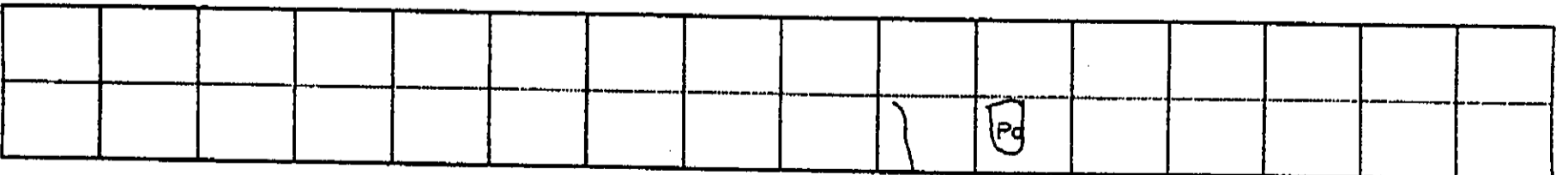
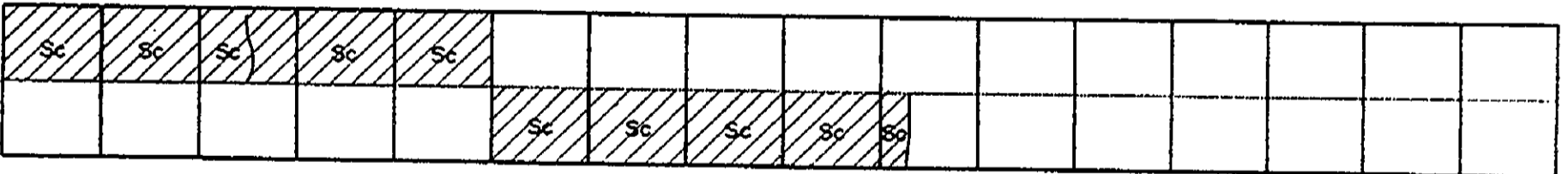
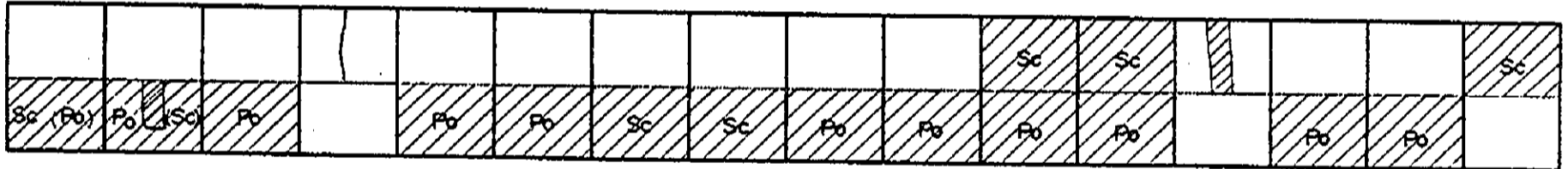
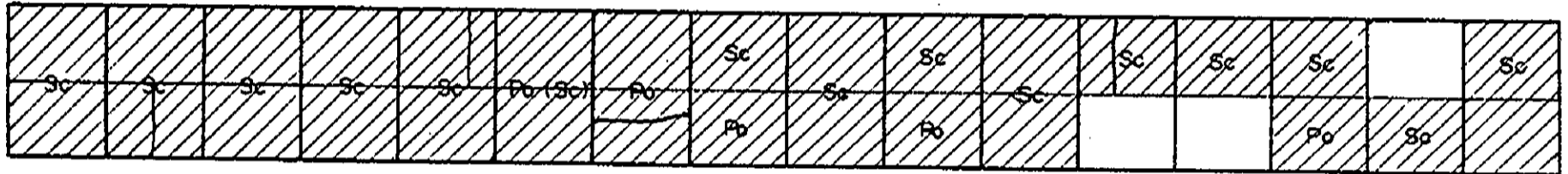
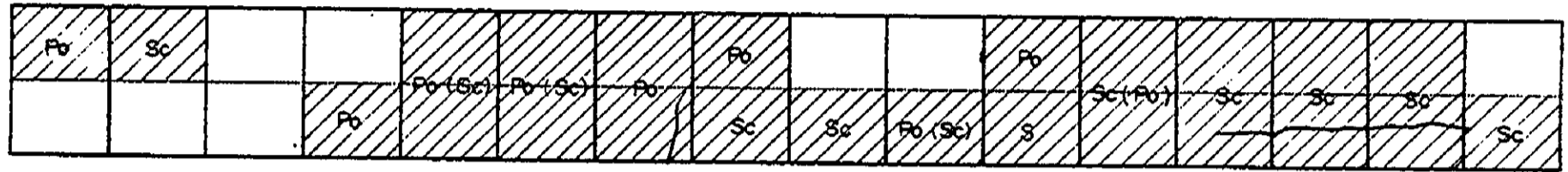
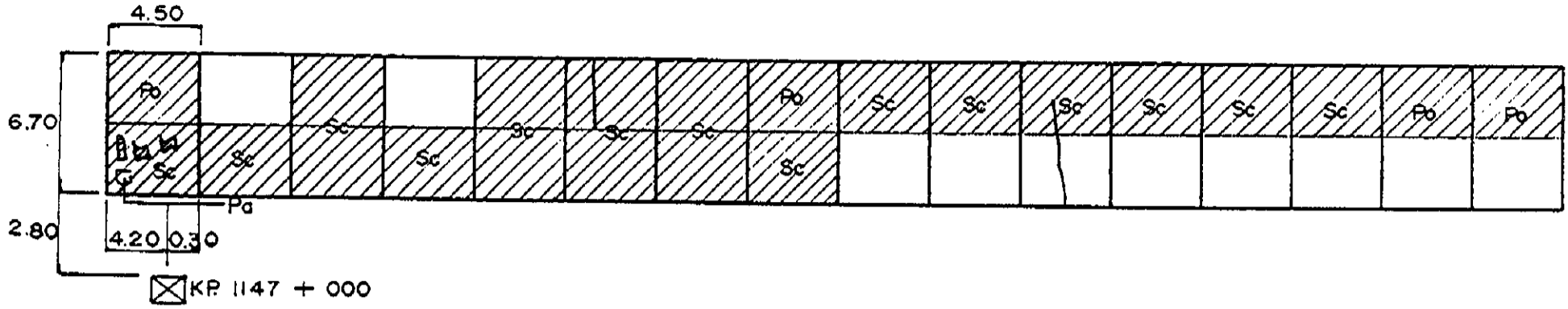

INVENTORY OF PAVEMENT SURFACE CONDITION

Km. 1148 + 000

Date : 11 - 17 - 95

Sheet No : 2/2

						~									

Sc	Sc														
												Sc	Sc	Sc	

										~	~	~	~	~	~

							Sc								
~															

				~	~	~	~							~	~

~	~	~													

				~	~	~	~								

4.45	3.30
2.25	3.35
2.20	3.40

INVENTORY OF PAVEMENT SURFACE CONDITION

Km. 1149+000

Date: 11-17-95

Sheet No: 2/2

			Sc	Sc	Sc										Sc

Sc	Sc	Sc	Sc	Sc					Sc	Sc				Sc	

Sc	Sc	Sc	Sc	Sc	Sc				Sc						

										Sc					

4.45
6.70
120 3.25 3.00
☒ KP1150+000

INVENTORY OF PAVEMENT SURFACE CONDITION

Km. 1150+000 & 1151+000

Date: 11-17-95

Sheet No: 2/4

-Start conc. shoulder
0.85 (Both Sides)

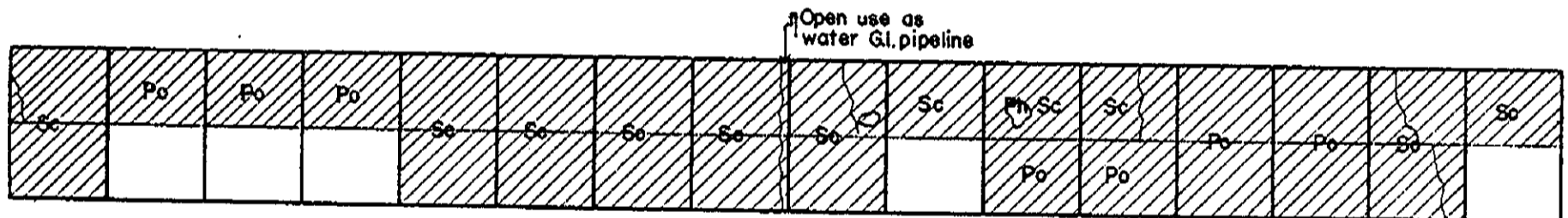
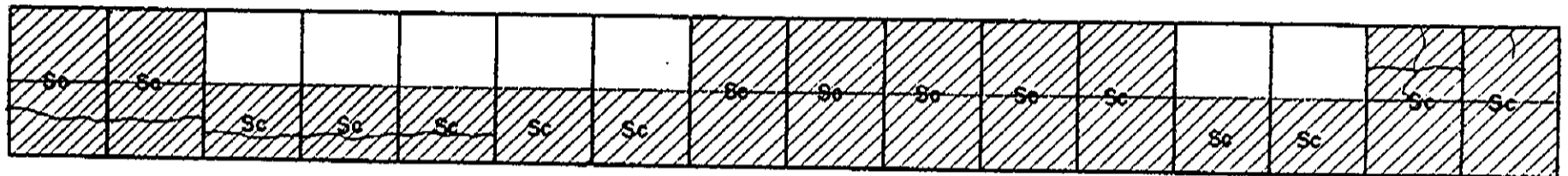
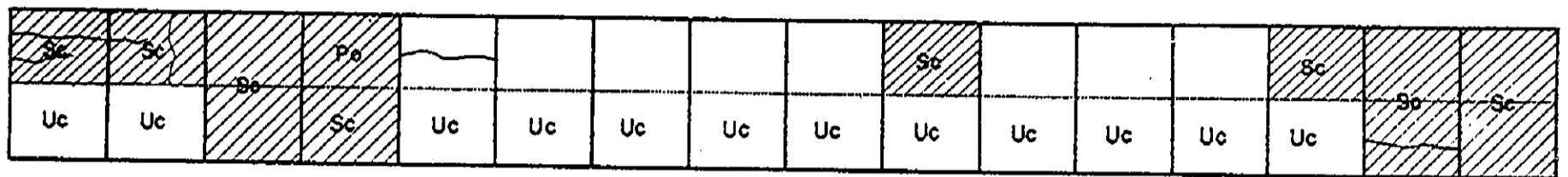
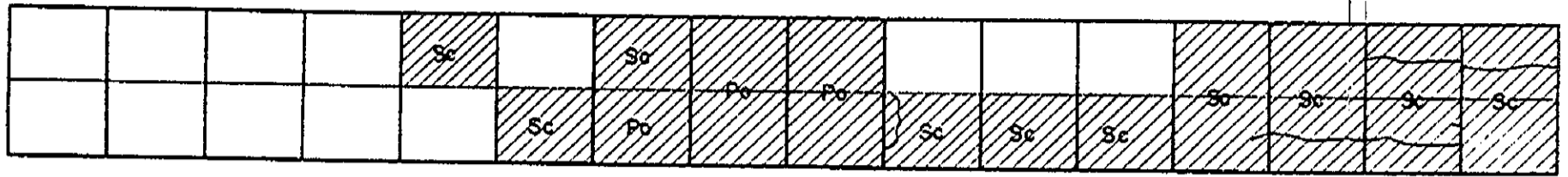

Open use as
water G.I. pipeline

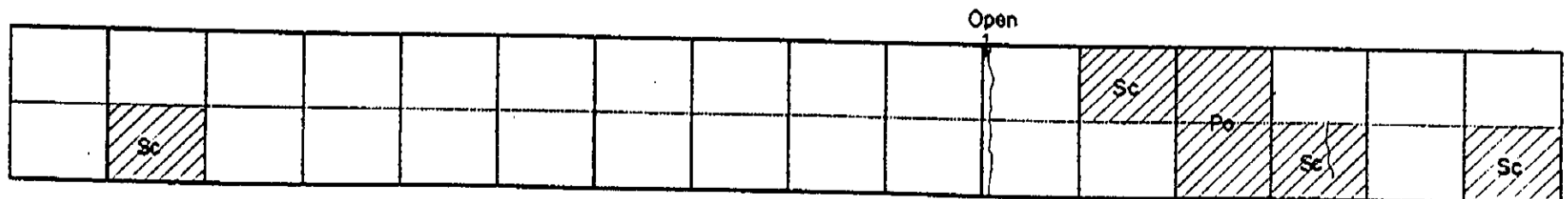
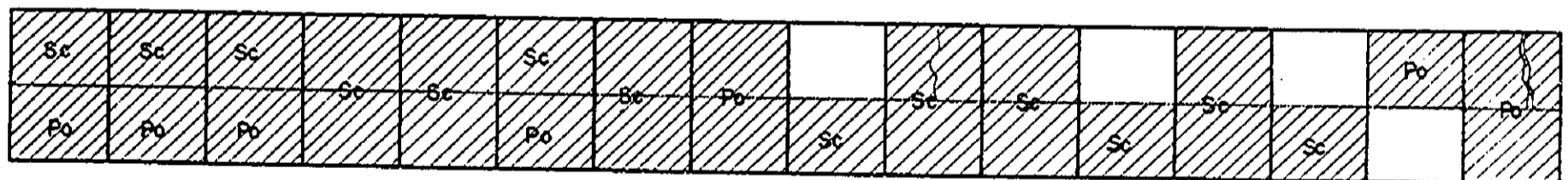

Open

INVENTORY OF PAVEMENT SURFACE CONDITION

Date : 11-18-95

Sheet No : 1/2

Km. 1152+000

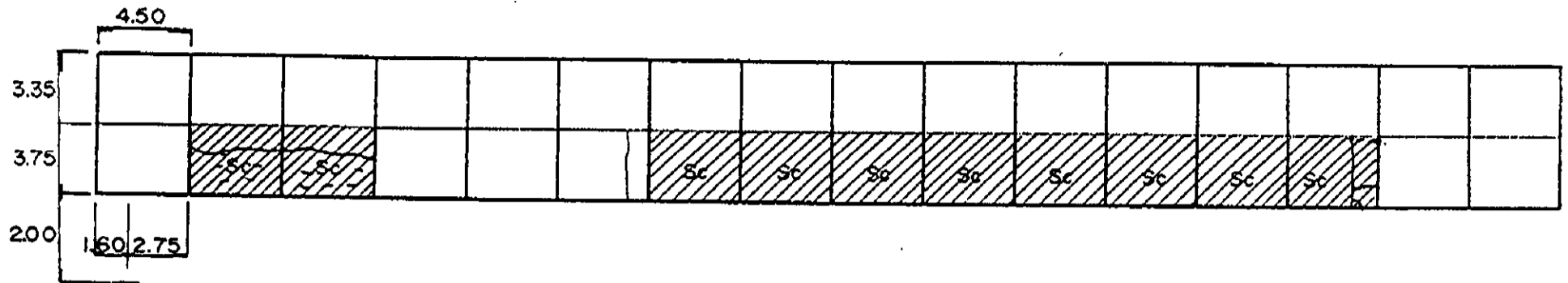

☒ KP1152+000

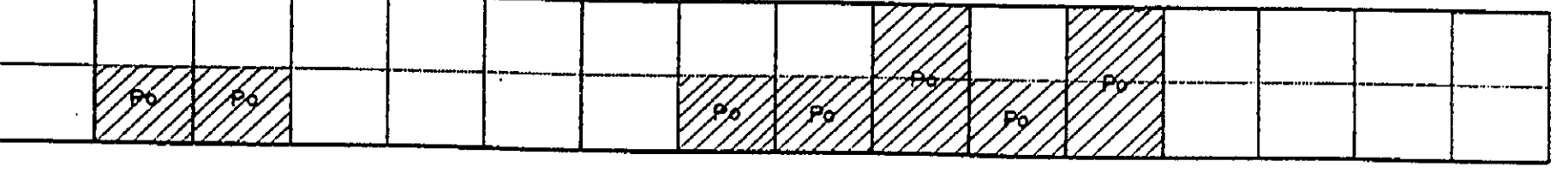
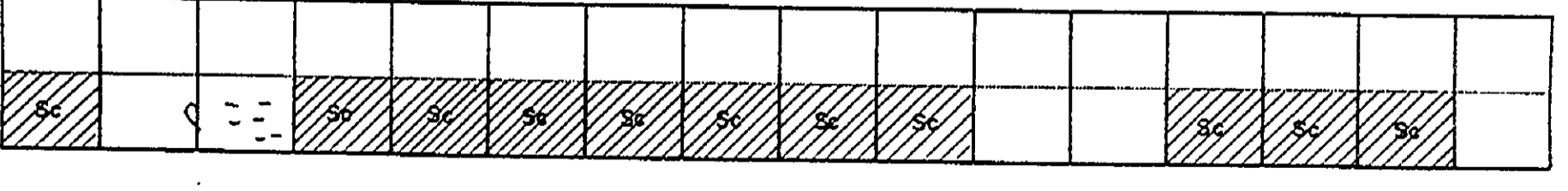
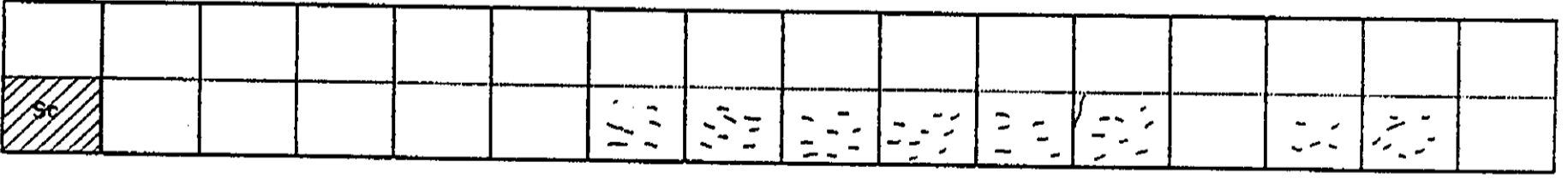
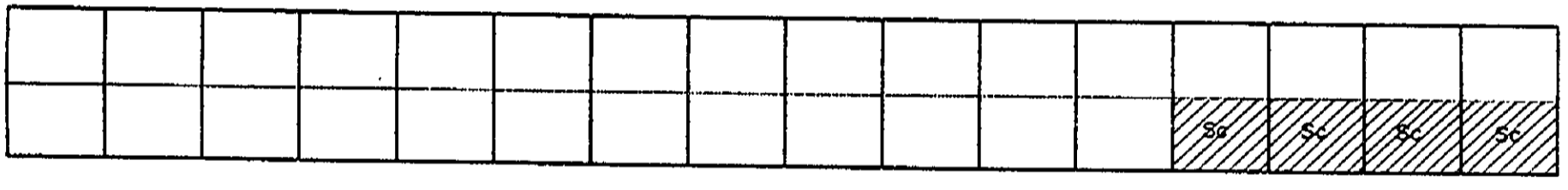
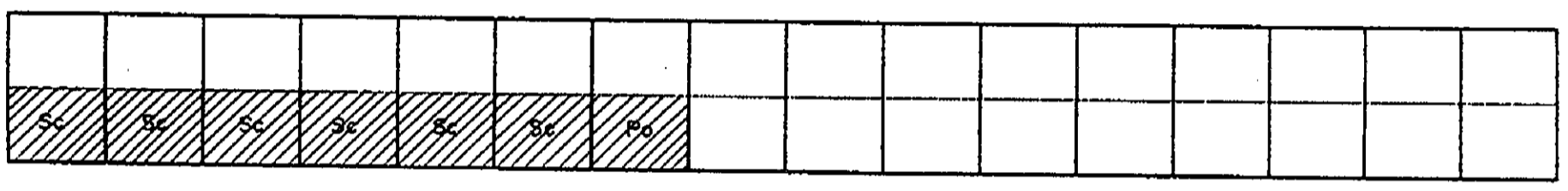
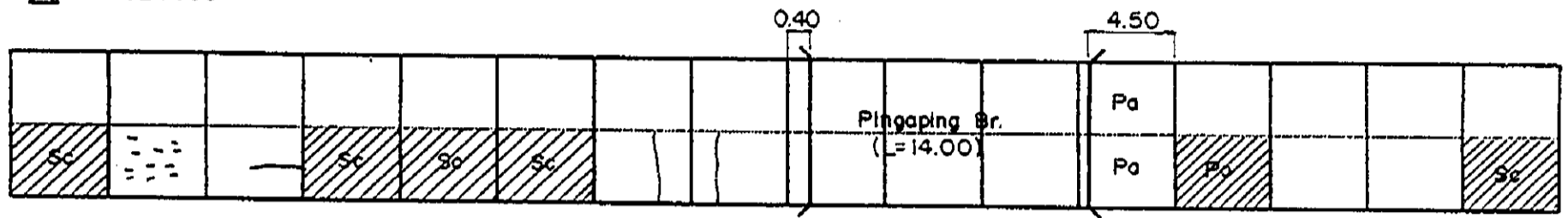

INVENTORY OF PAVEMENT SURFACE CONDITION

Km. 1152+000

Date: 11-18-95

Sheet No: 2/2

		/									-	-	-			
	Po	Po	-	-		Po	Po	Po	Po	-	Po	-	-	Po	-	-

-		-														
Po	Po	-	-	-	-	-		Po		Po						

								-								
	-		-	-	-	-	-	-	-	-	-	-	-	Po	Po	Po

	Po	Po	Po		Po	Po	Po	Po	Po	-	-	Po	-	-	-	Po

Po	Po	Po	-	-				-		Sc						

	-															
	Po	Po	Po	Po	Po	Po	Po	Po	Po	Po	Po	Po	Po	Po	Po	Po

			/													
Po	Po	Sc (Po)	Sc	Sc	-	Fc	Sc	Sc	Sc	Po	Po	Po	Po	Po	Po	6.70

4.50

2.60