

INVENTORY OF PAVEMENT SURFACE CONDITION

Date: 10-28-95

Sheet No: 1/2

Km. 1386+000

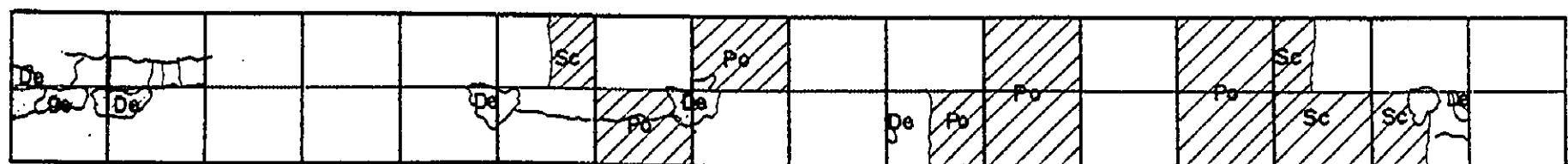
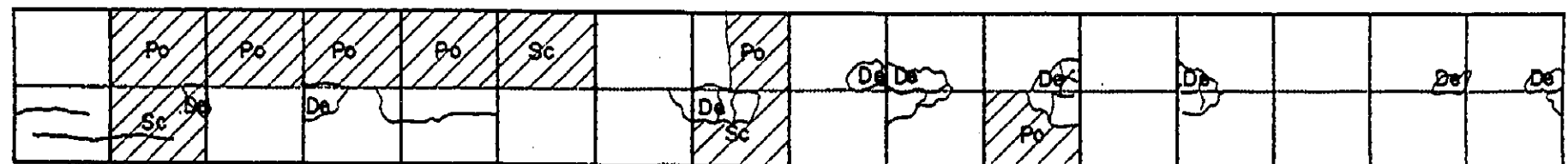
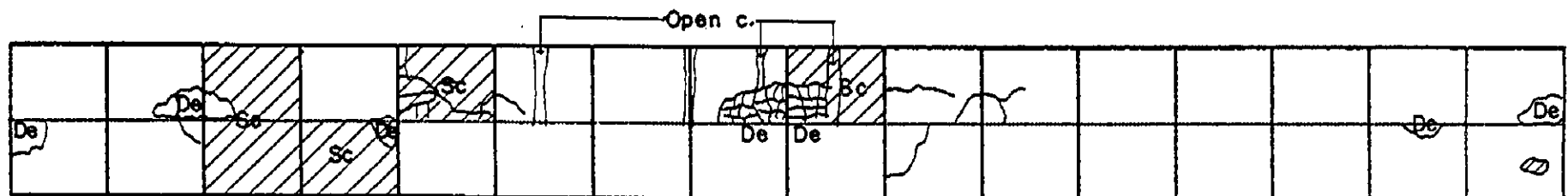
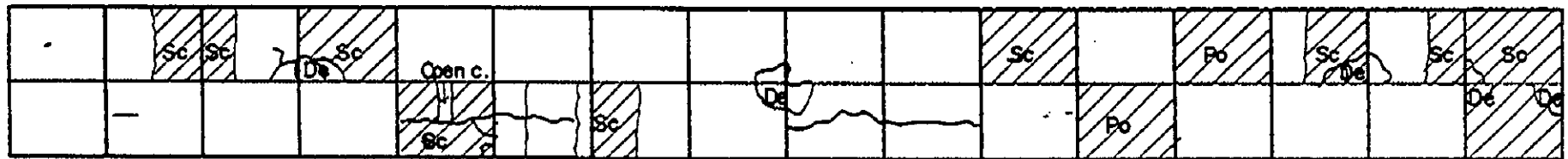
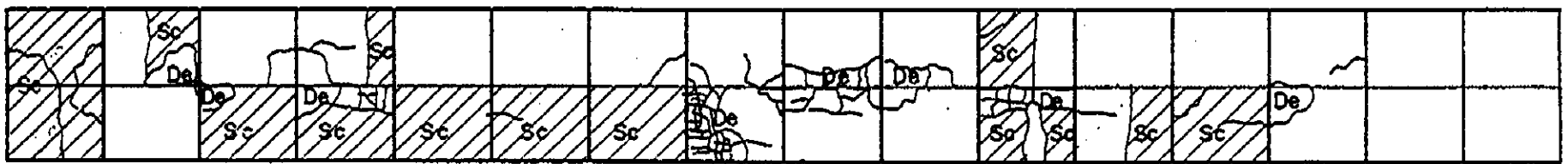
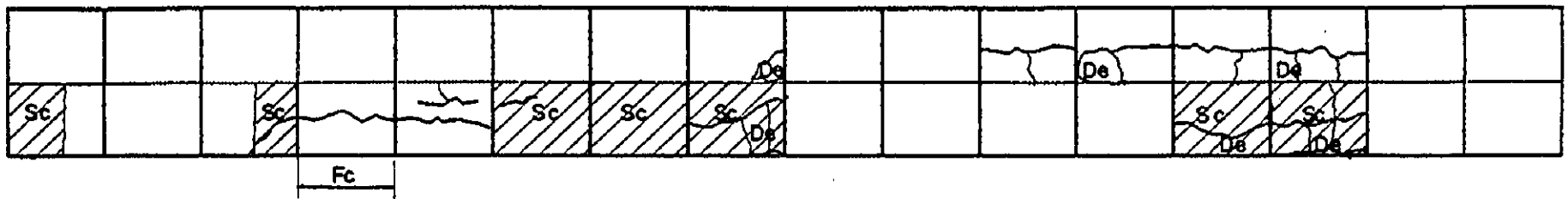
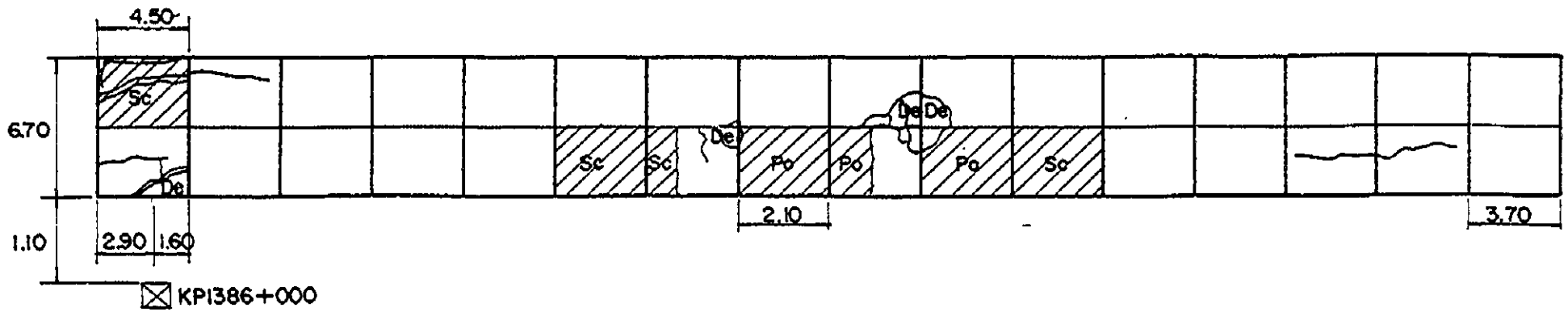

INVENTORY OF PAVEMENT SURFACE CONDITION

Km. 1386+000

Date : 10-28-95

Sheet No : 2/2

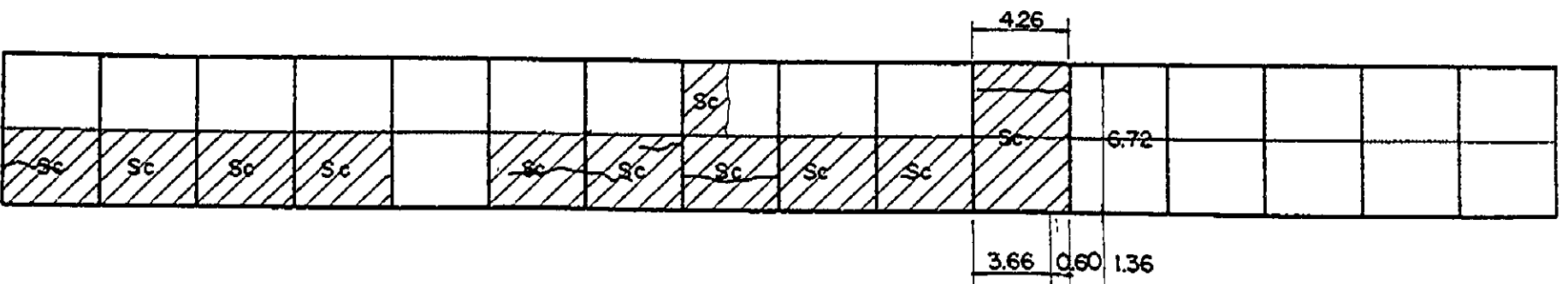
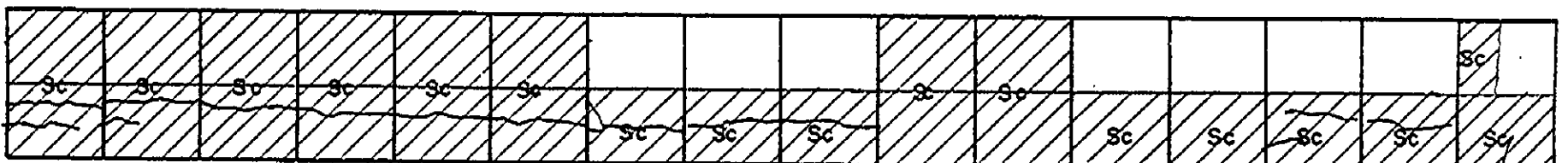
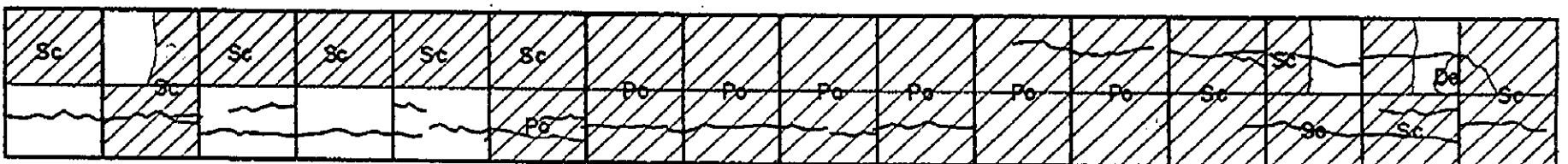
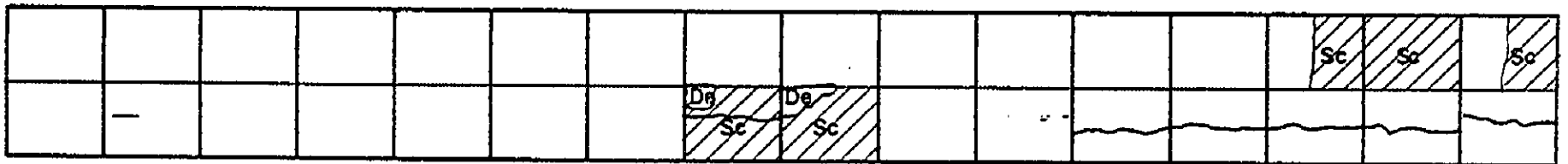
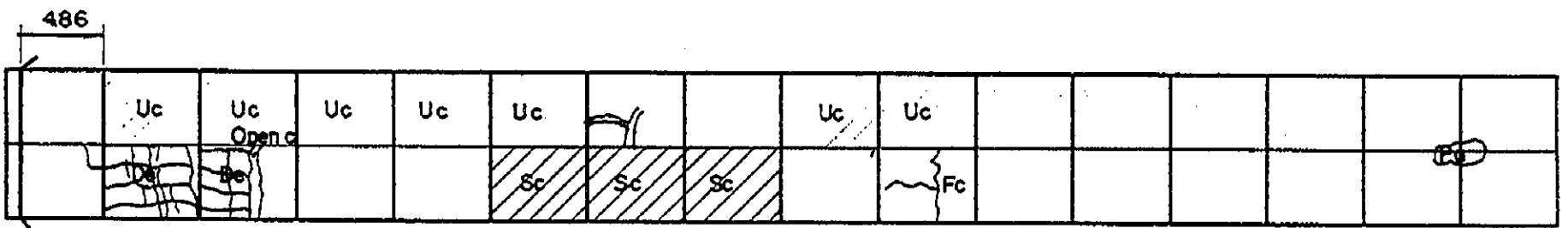
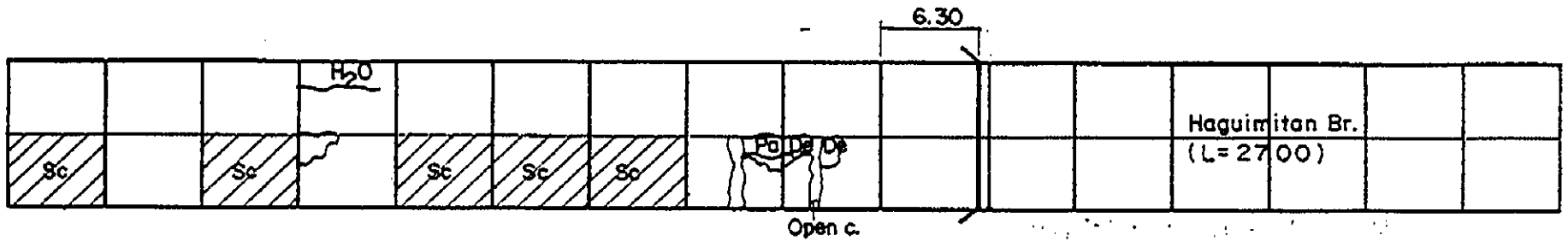
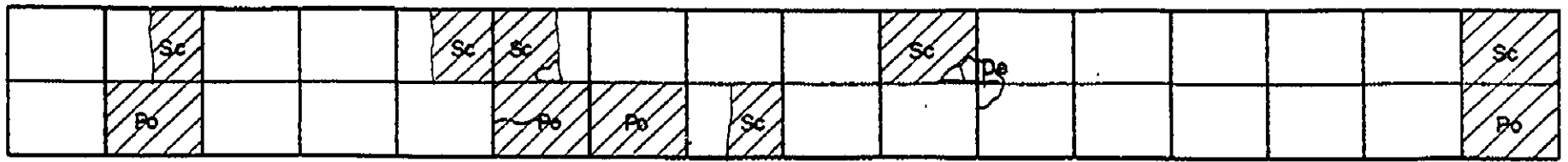

INVENTORY OF PAVEMENT SURFACE CONDITION

Date: 10-28-95

Km. 1387+000

Sheet No: 1/3

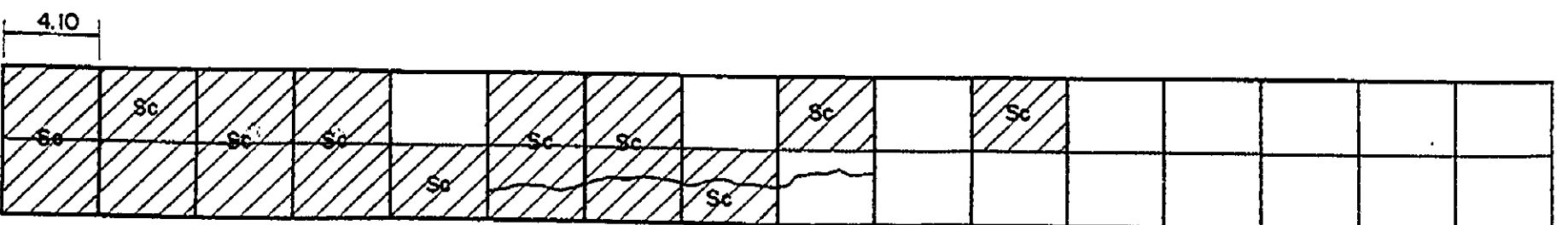
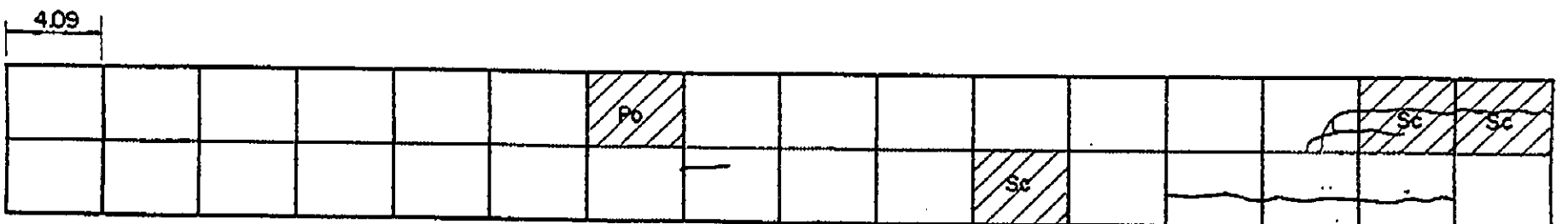
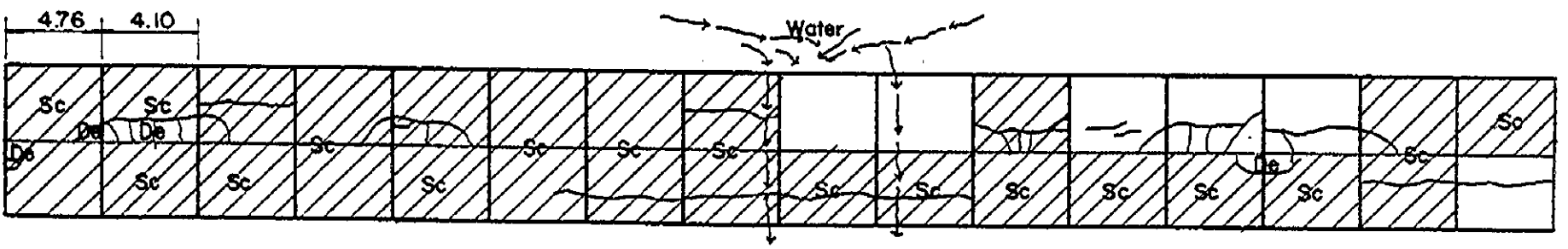
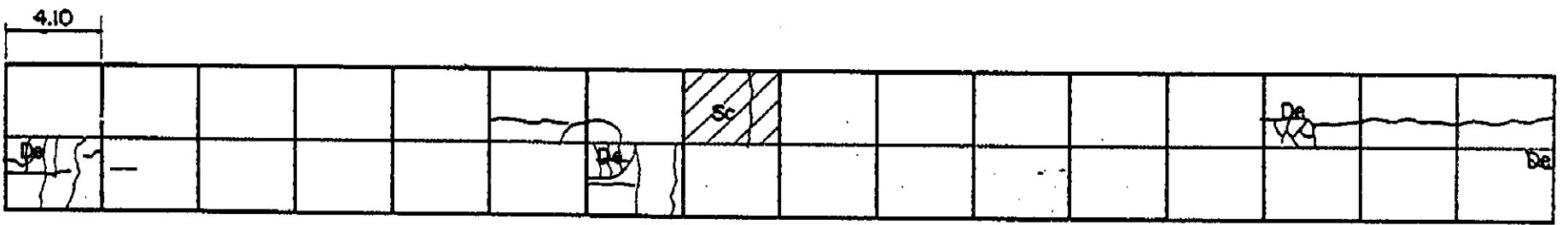
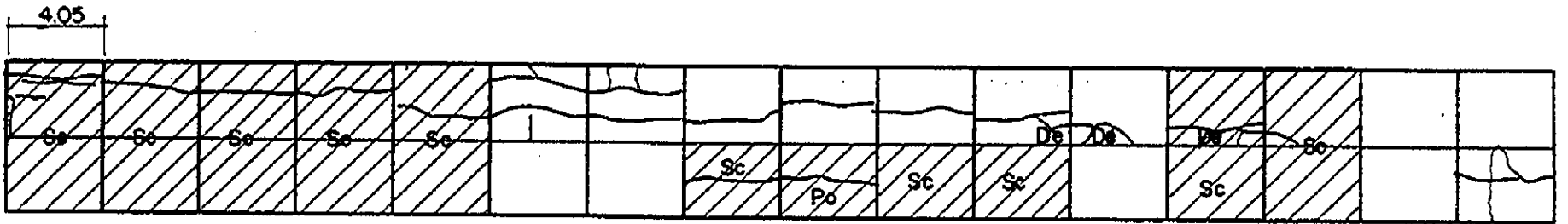
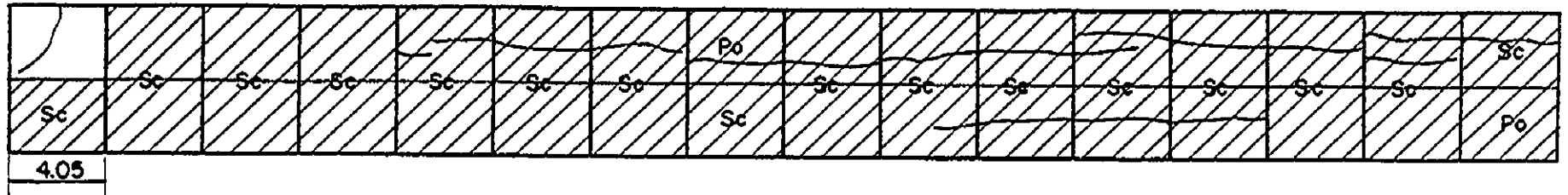
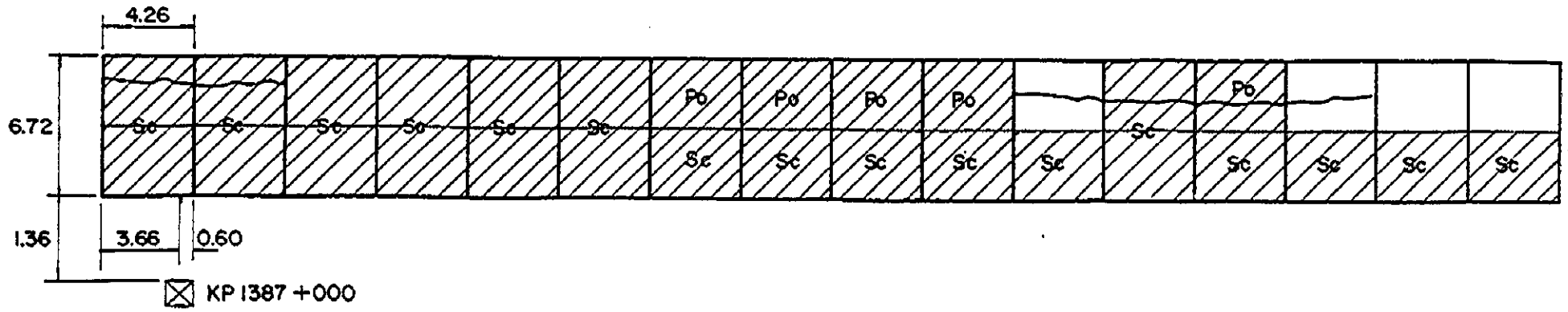

INVENTORY OF PAVEMENT SURFACE CONDITION

Date: 10-28-95

Km. 1387+000

Sheet No: 2/3

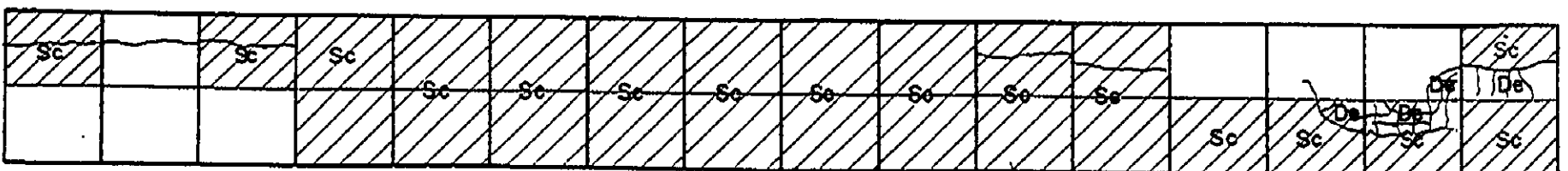
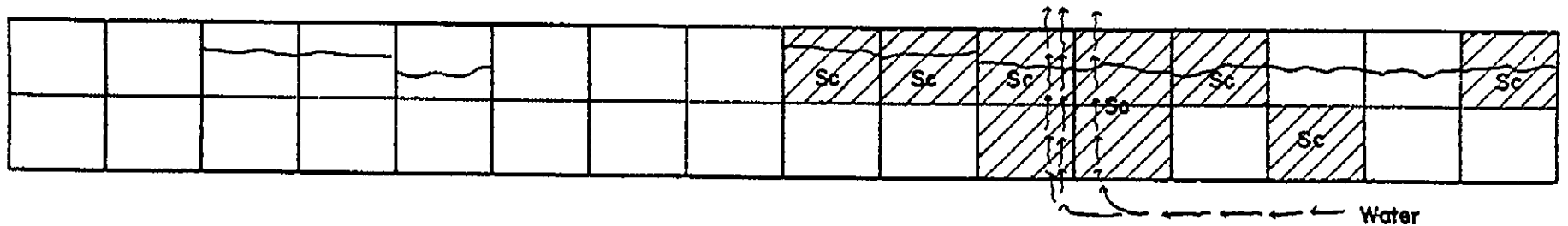
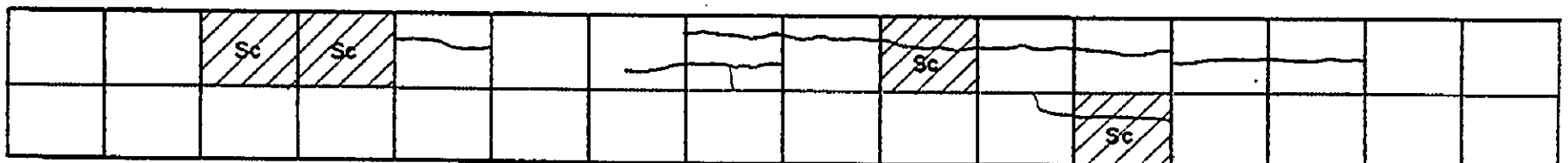
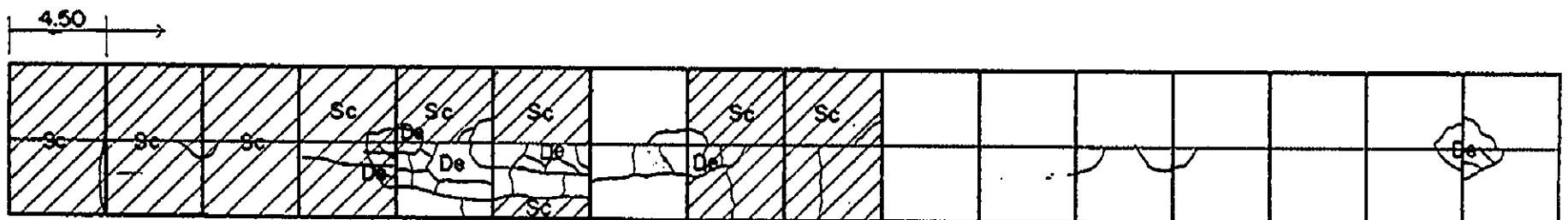
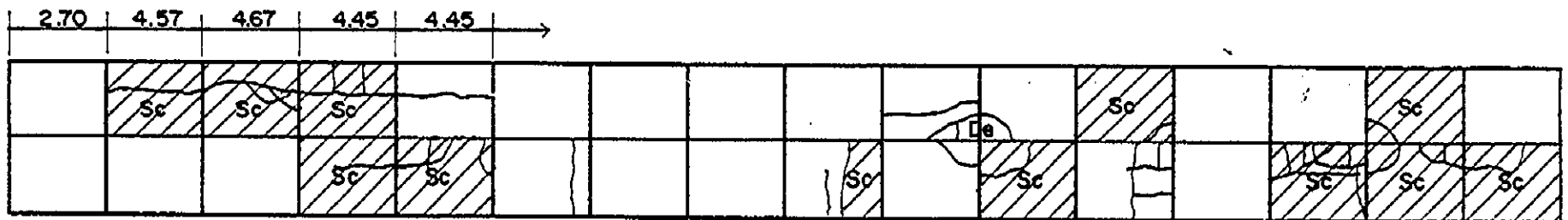
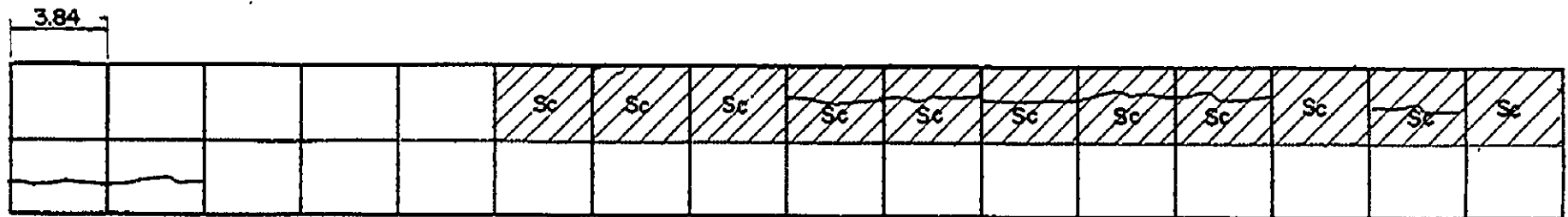
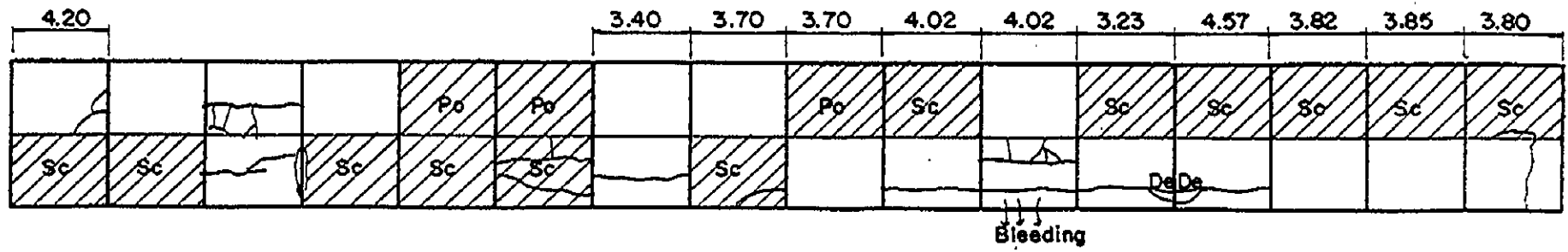

INVENTORY OF PAVEMENT SURFACE CONDITION

Date: 10-28-95

Sheet No: 1/3

Km. 1388 + 000

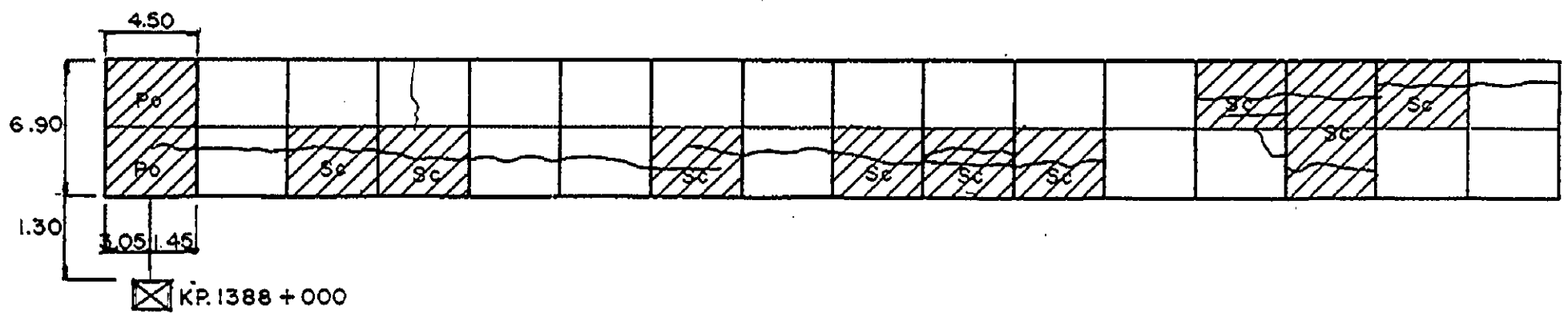

Water Seepage

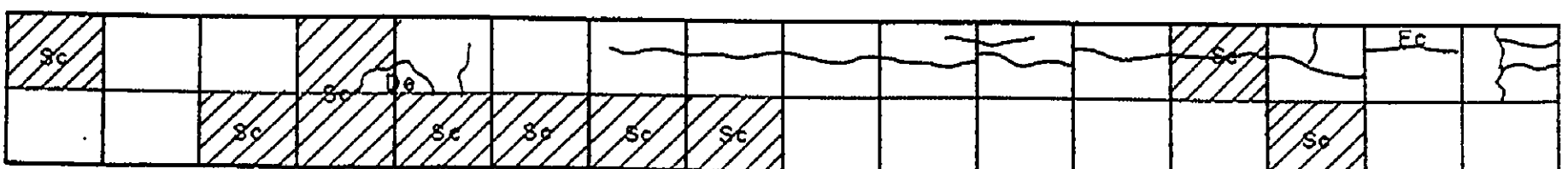
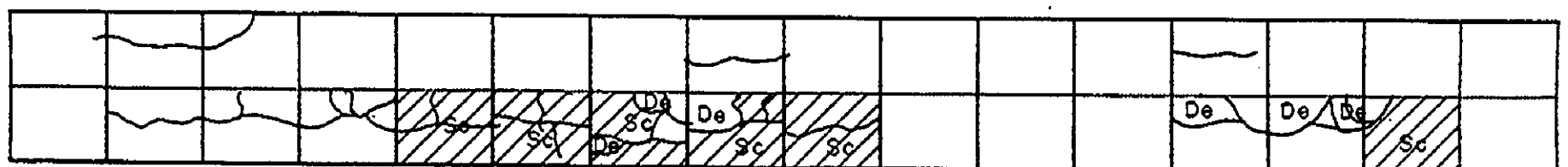
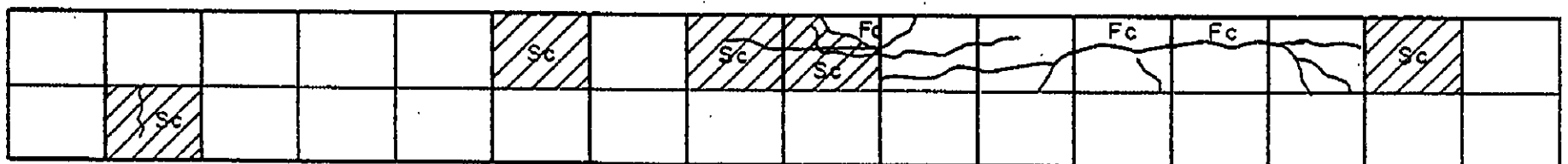
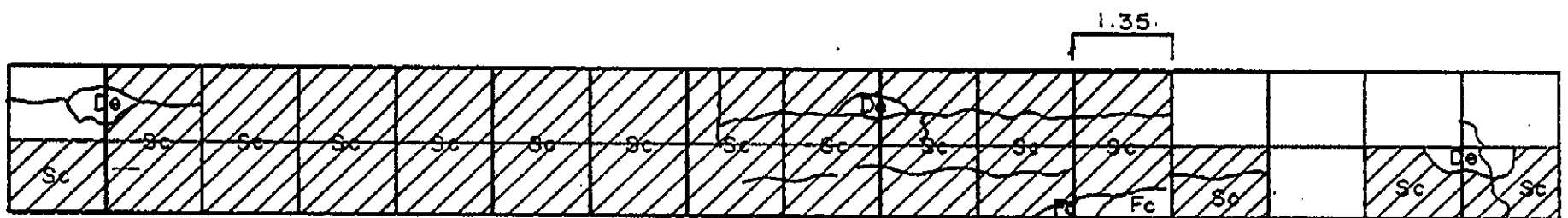
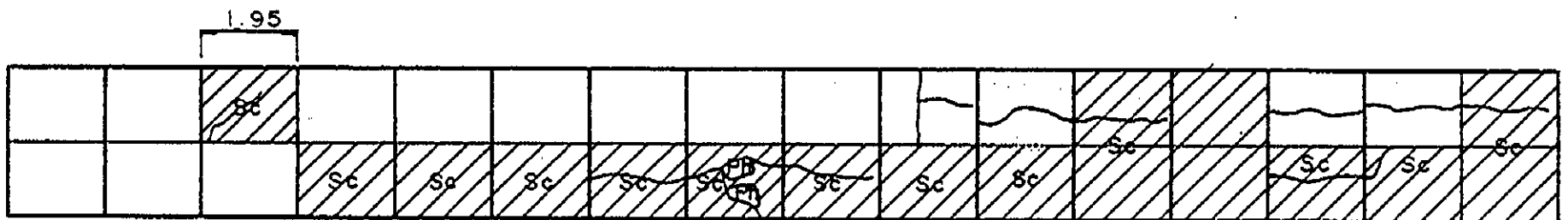
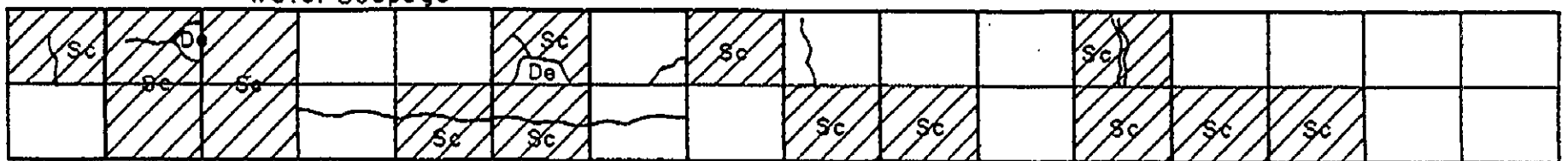

INVENTORY OF PAVEMENT SURFACE CONDITION

Date: 10-28-95

Km. 1388 + 000

Sheet No: 2/3

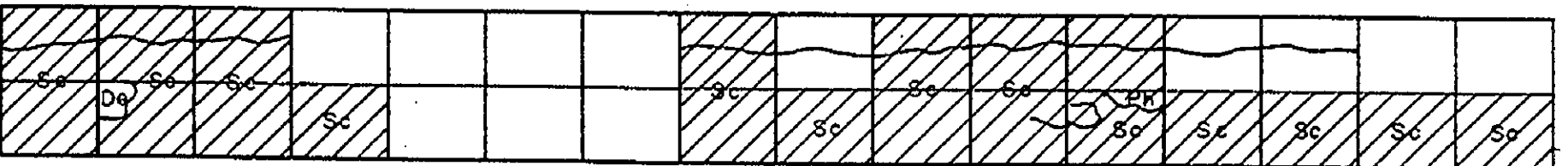
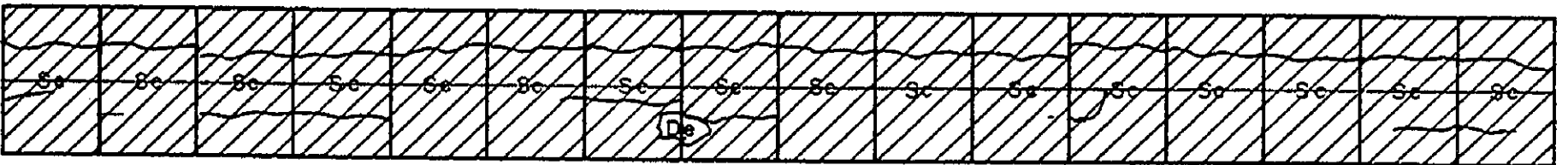
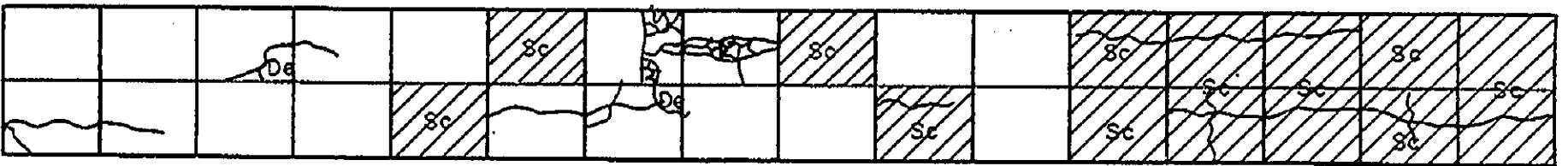
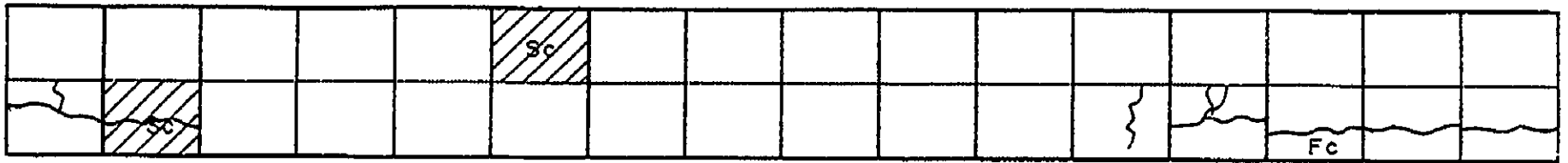
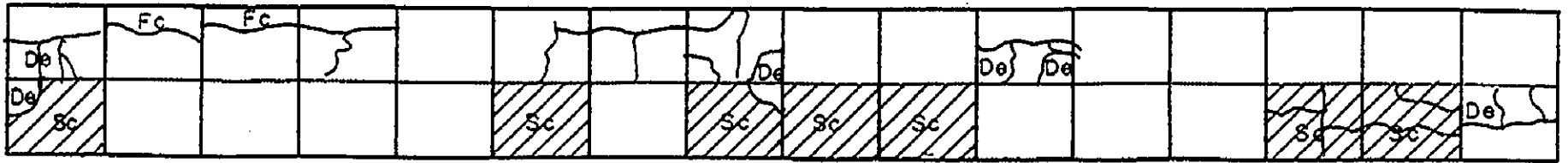

Water Seepage :

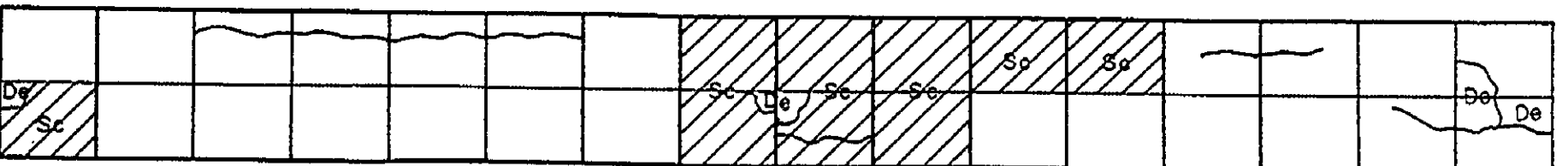
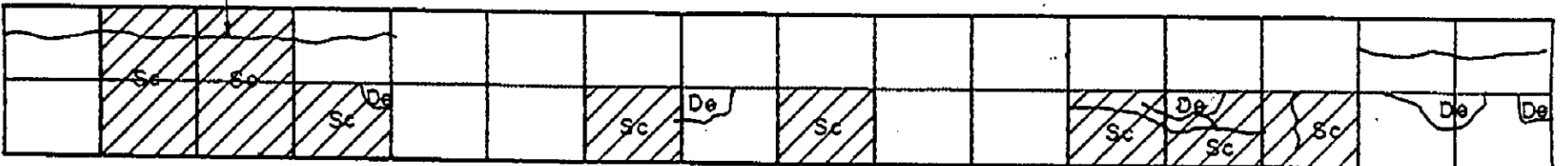

INVENTORY OF PAVEMENT SURFACE CONDITION

Date: 10-28-95

Sheet No: 1/2

Km. 1389+000

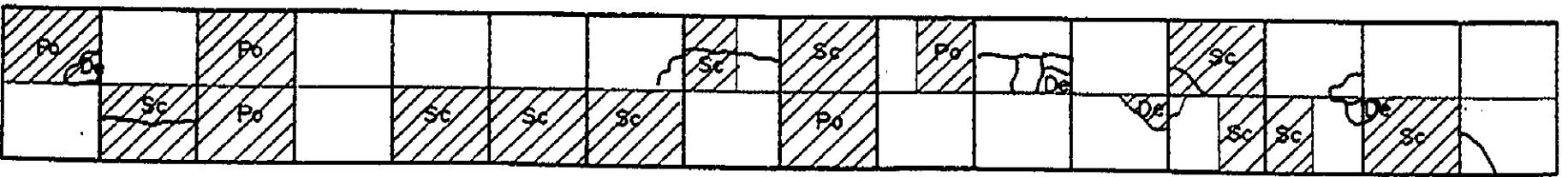
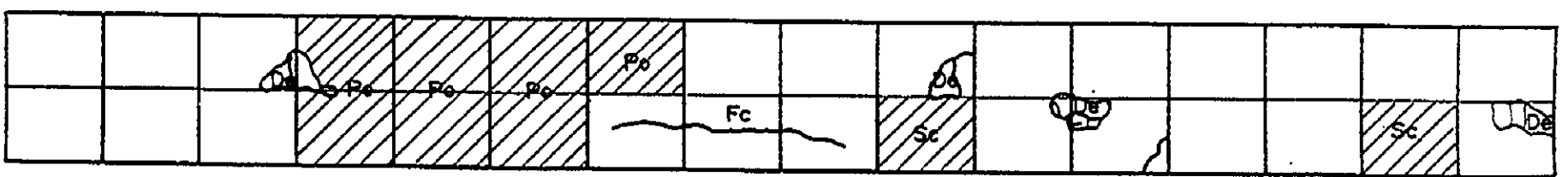
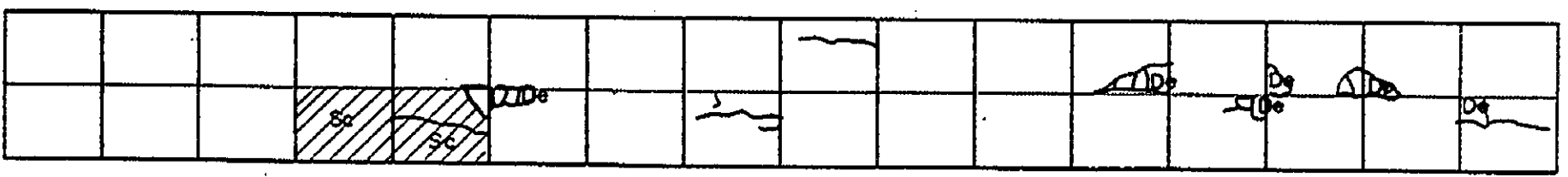
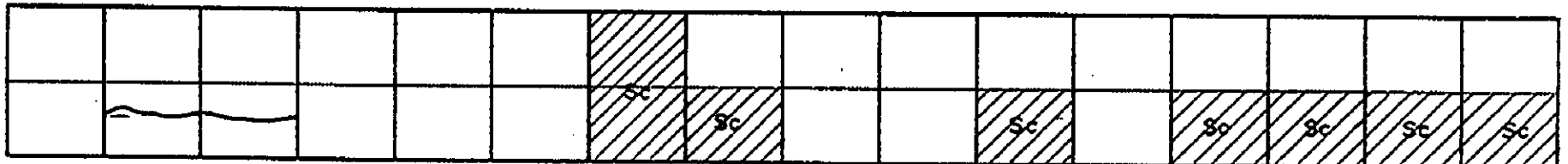
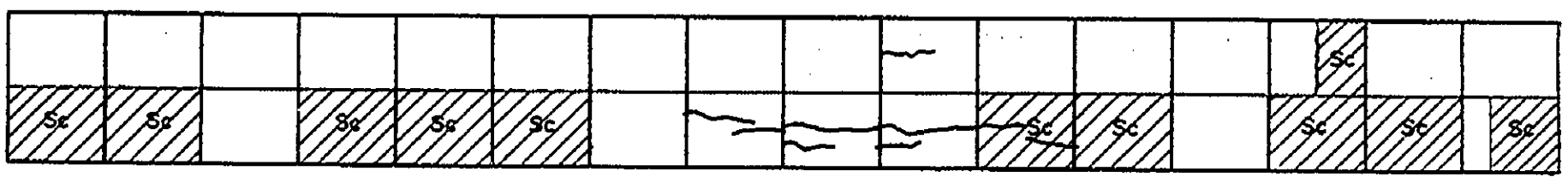
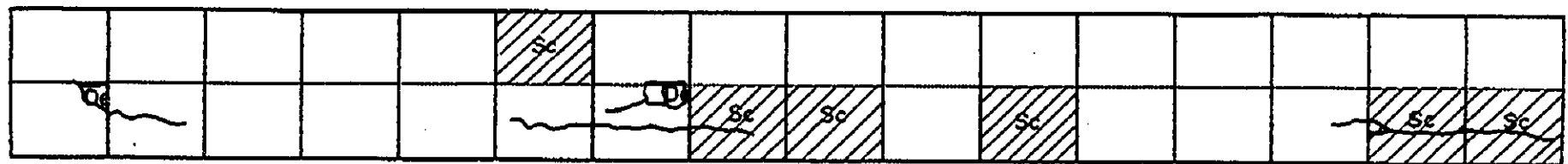
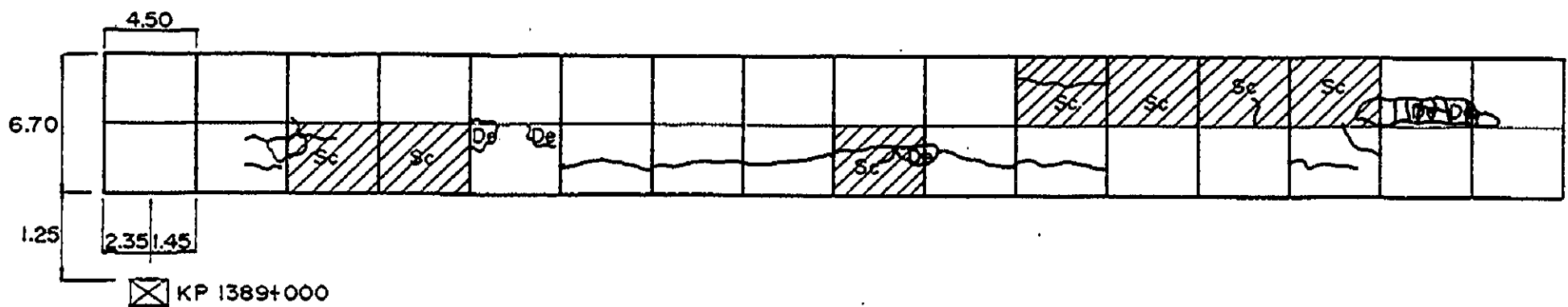

INVENTORY OF PAVEMENT SURFACE CONDITION

Km. 1389+000

Date: 10-28-95

Sheet No: 2/2

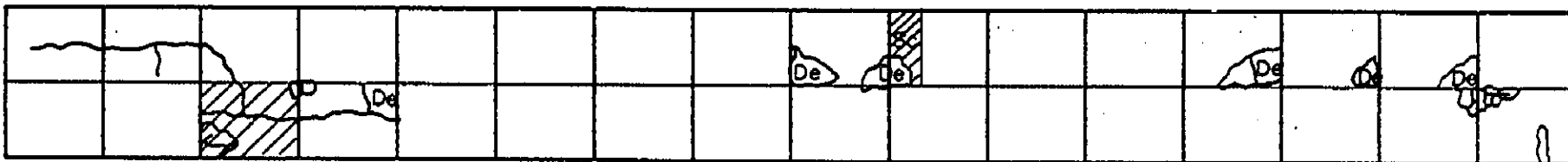
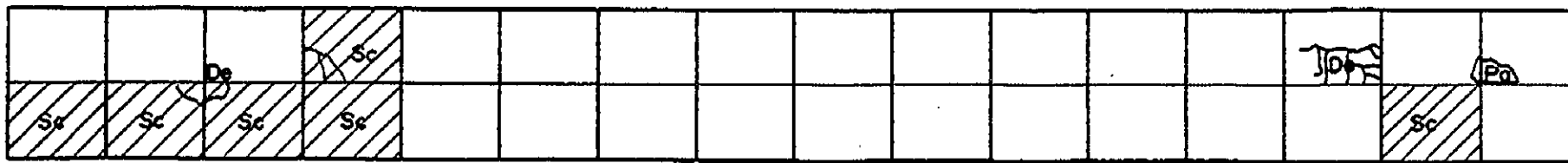

Open C

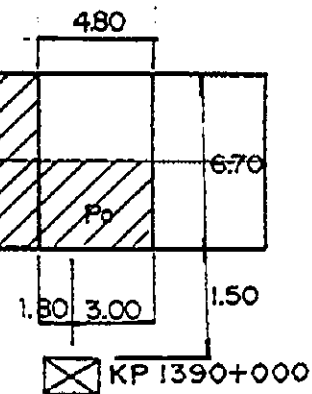
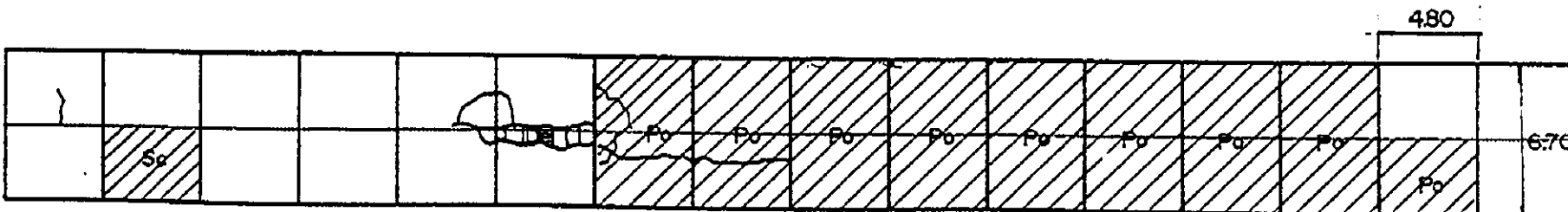
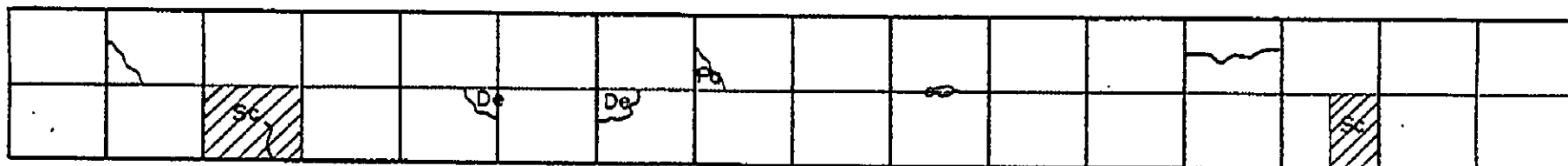
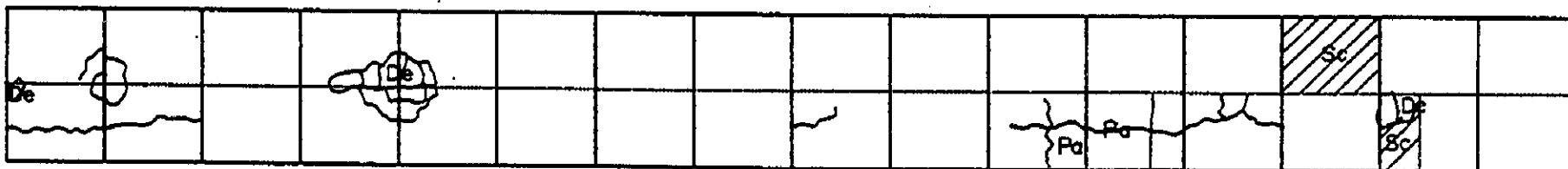
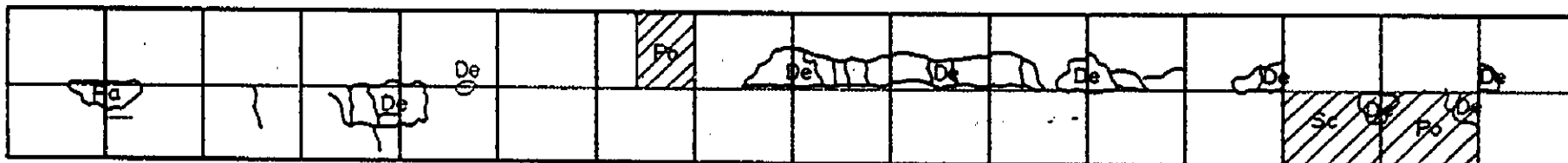

INVENTORY OF PAVEMENT SURFACE CONDITION

Date: 10-28-95

Km. 1390+000 & 1391+000

Sheet No: 1/4

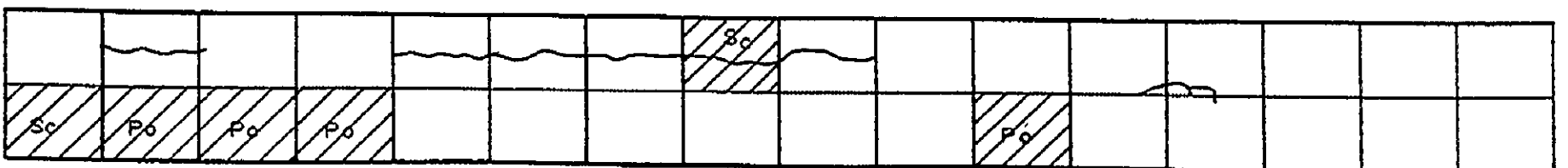
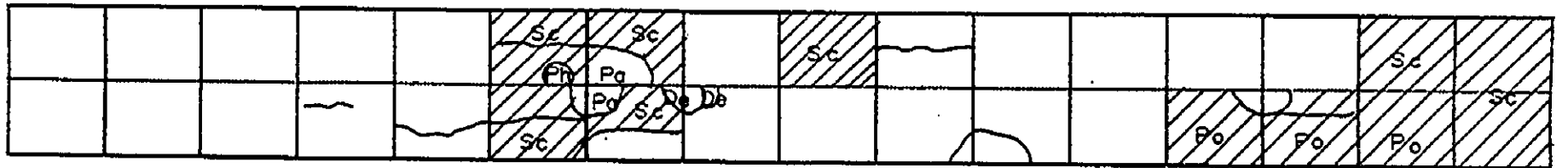
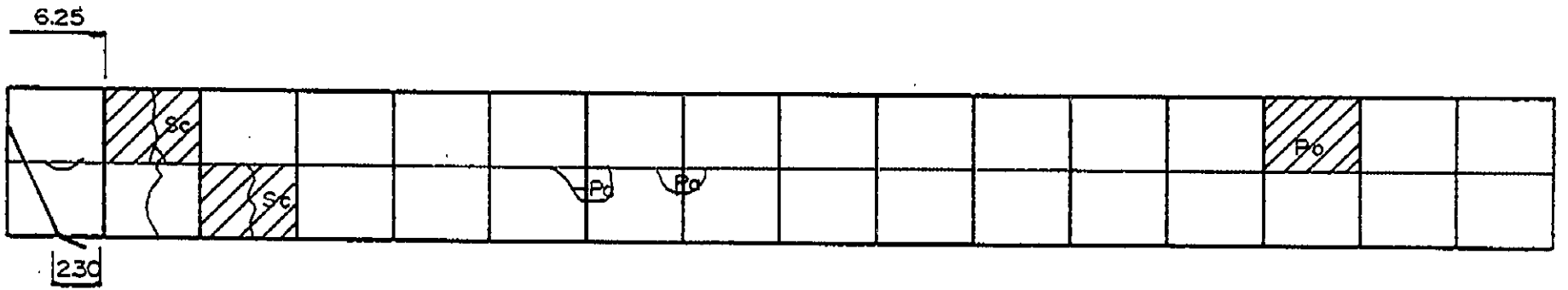
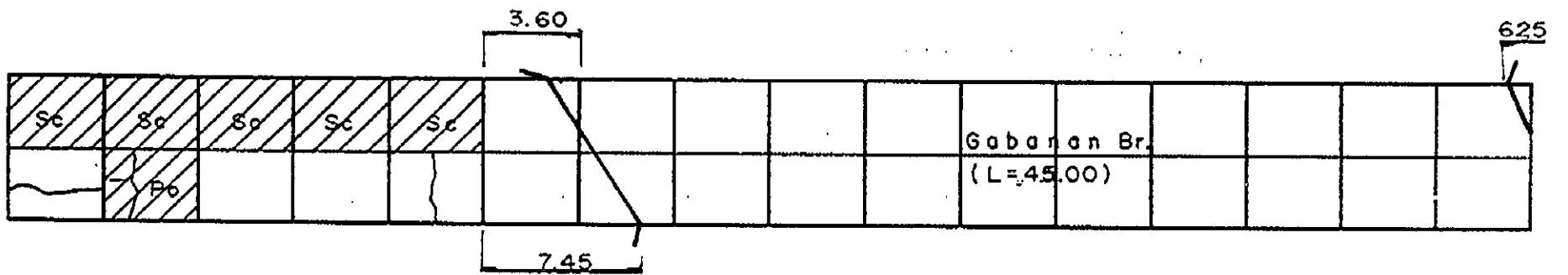
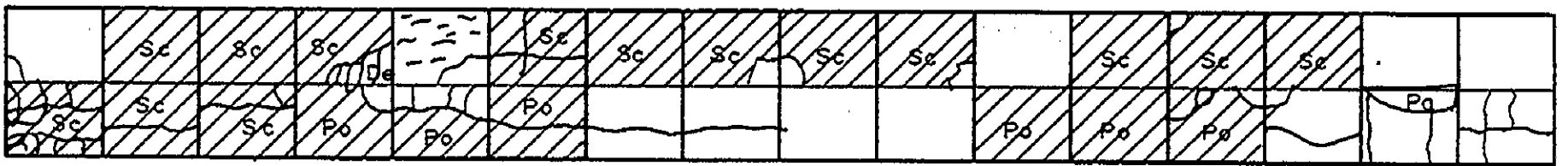
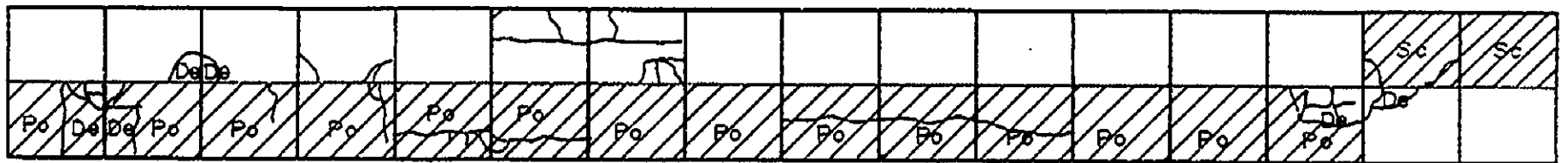
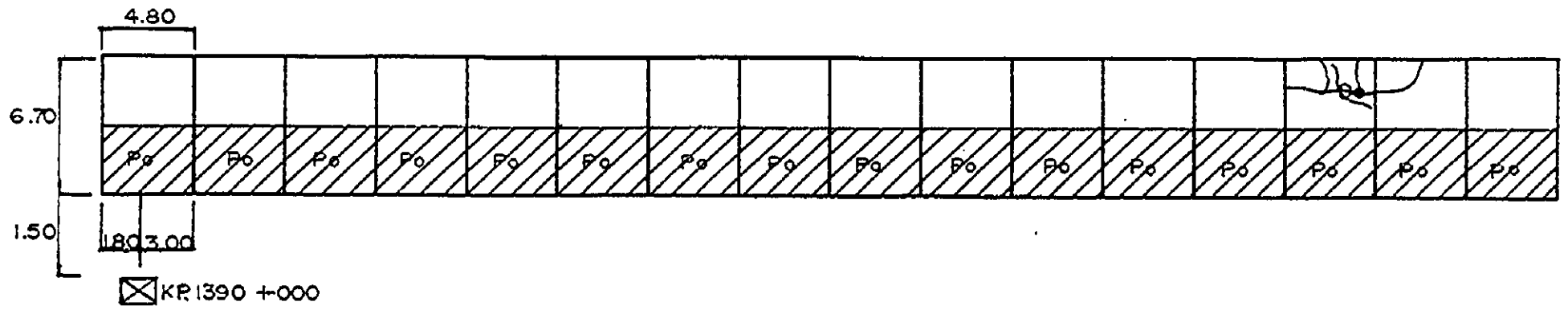

INVENTORY OF PAVEMENT SURFACE CONDITION

Date : 10-28-95

Km. 1390+000 & 1391+000

Sheet No : 2/4

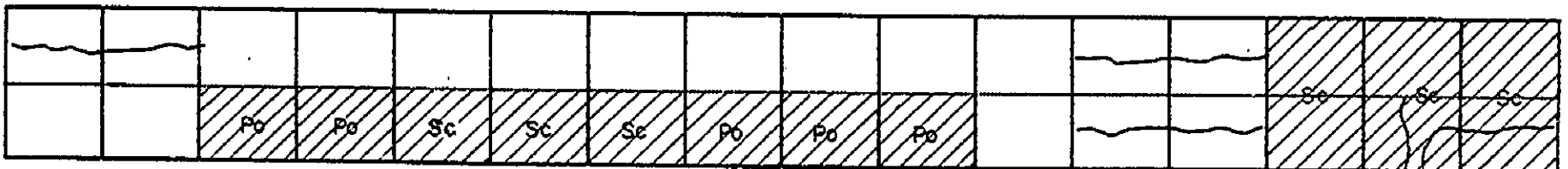
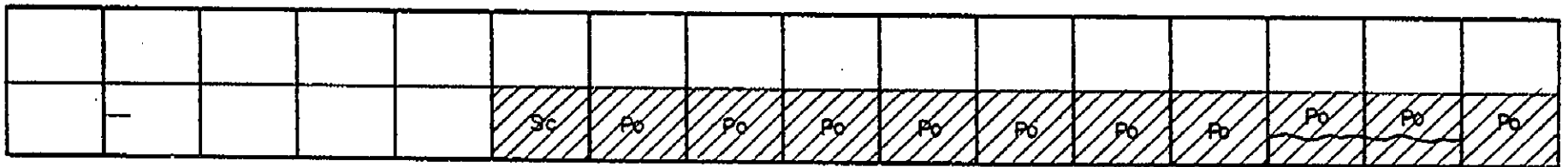
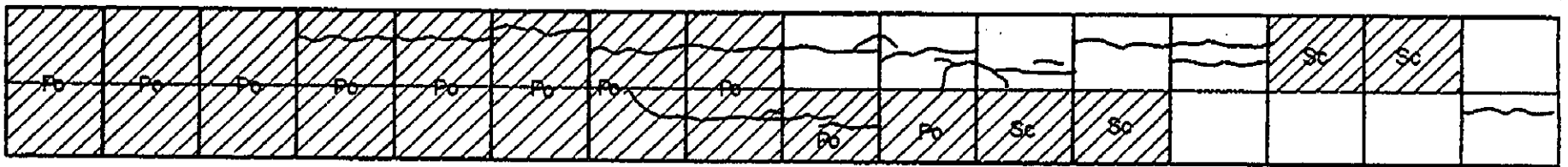
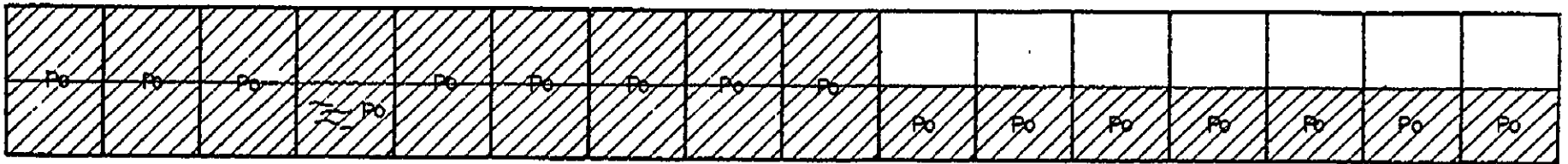
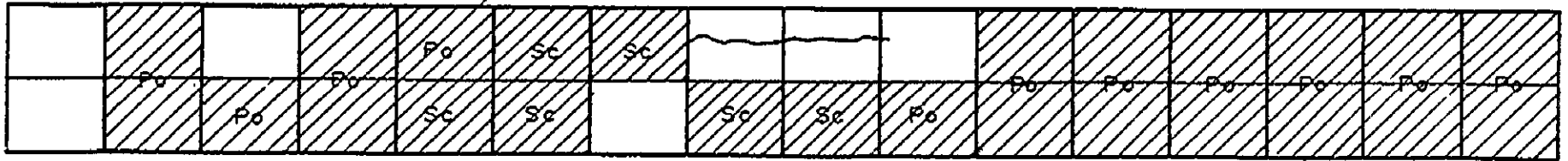

$$15.40 + 30 + 30 + 30 + 30 + 30 + 560 = 171.00$$

Pavement can not be seen because
of the on-going construction of Buay Bridge

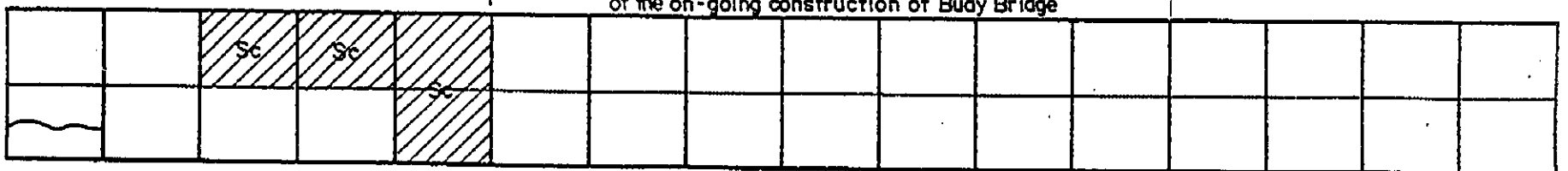

Buay Bridge (3 - Spans under Construction)

(171.00 m = 38 Blocks covered)

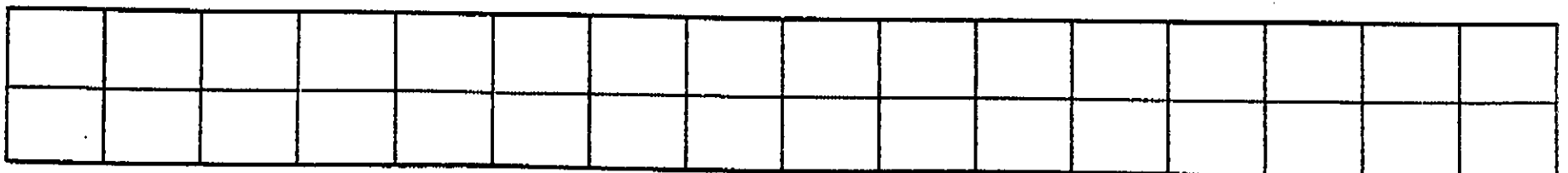

INVENTORY OF PAVEMENT SURFACE CONDITION

Date: 10-28-95

Km. 1390 + 000 & 1391+000

Sheet No: 4/4

Bleeding

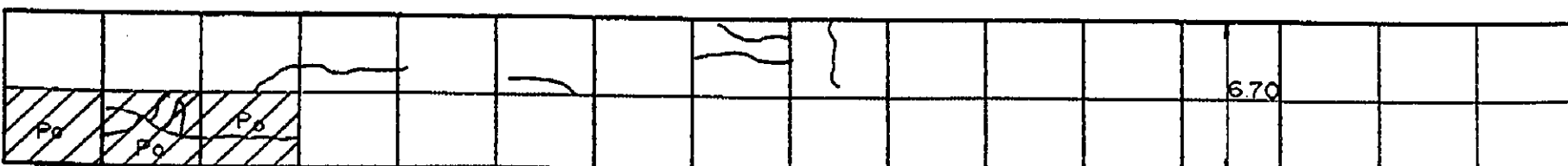
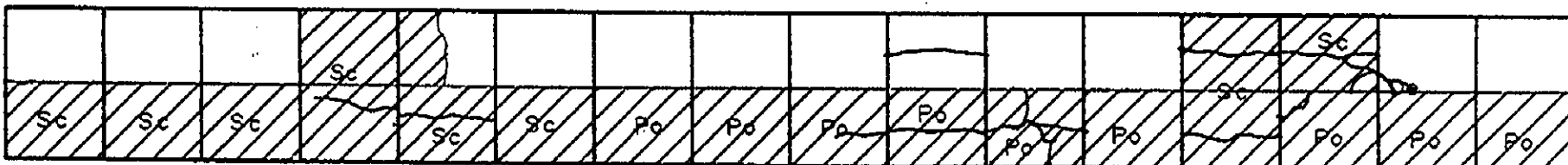
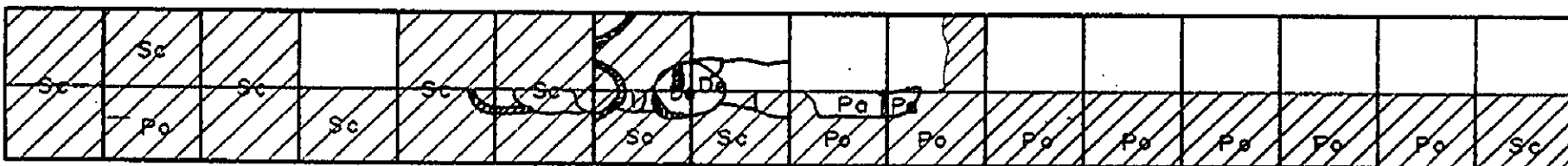
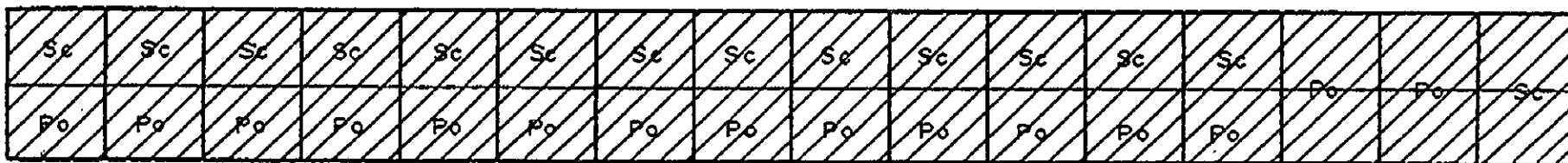
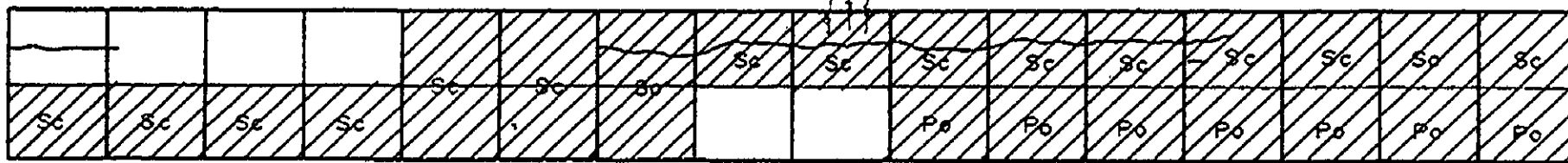

670

1.60

⊗ KP 1392 + 000

INVENTORY OF PAVEMENT SURFACE CONDITION

Date: 10-28-95

Sheet No: 1/2

Km. 1392 + 000

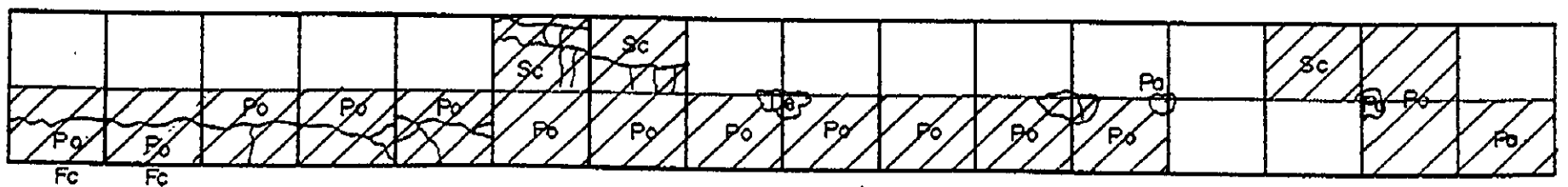
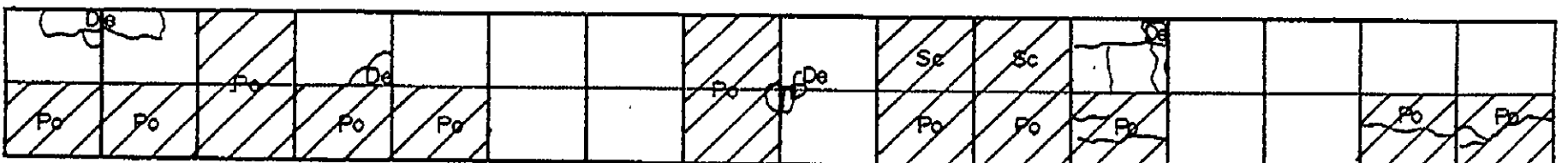
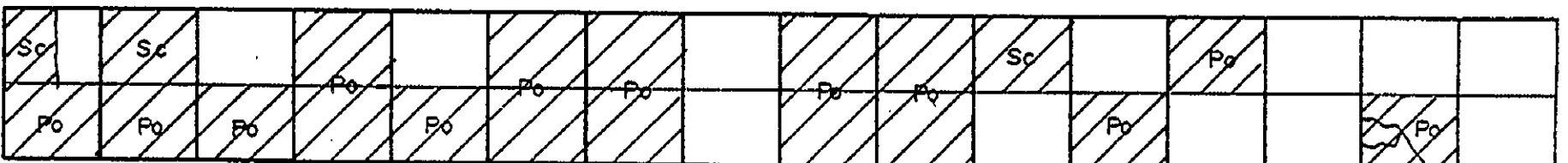
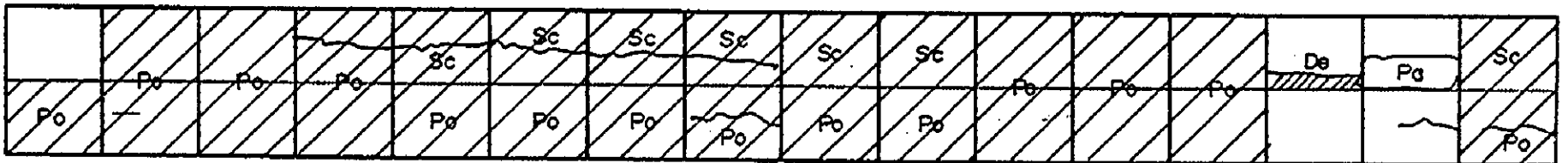
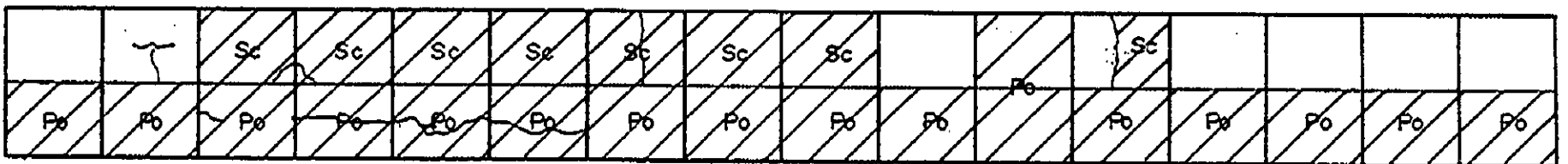
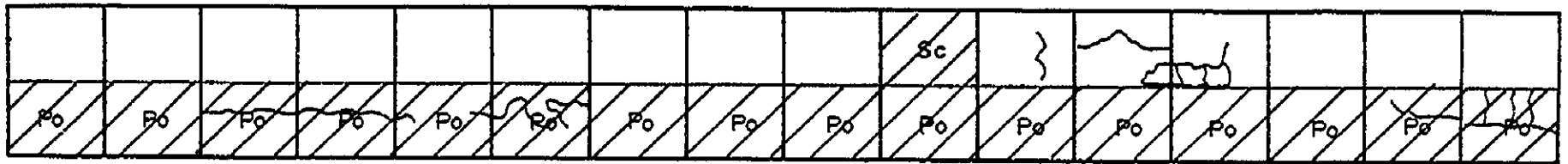
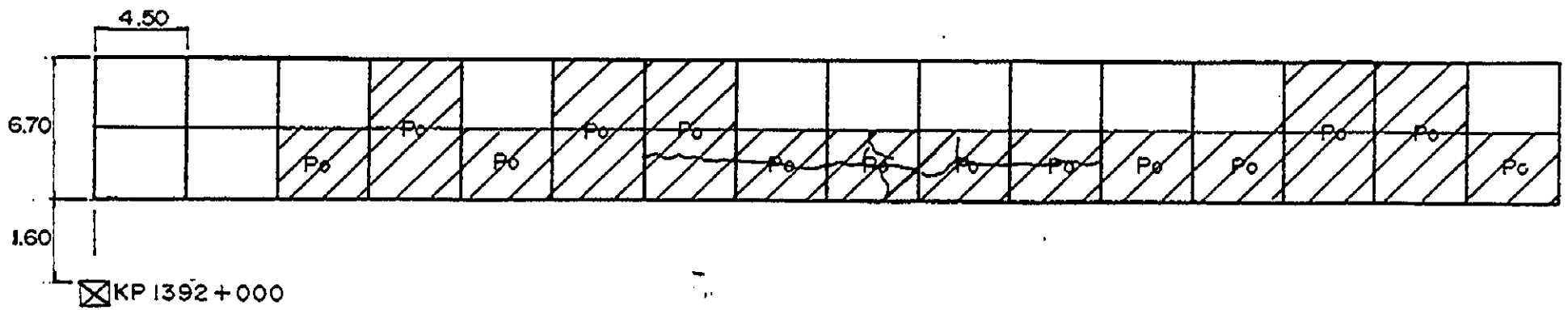

INVENTORY OF PAVEMENT SURFACE CONDITION

Km. 1392+000

Date: 10-28-95

Sheet No: 2/2

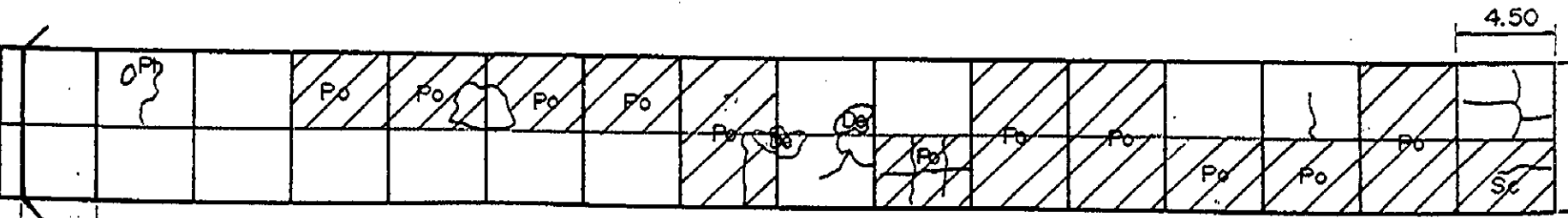
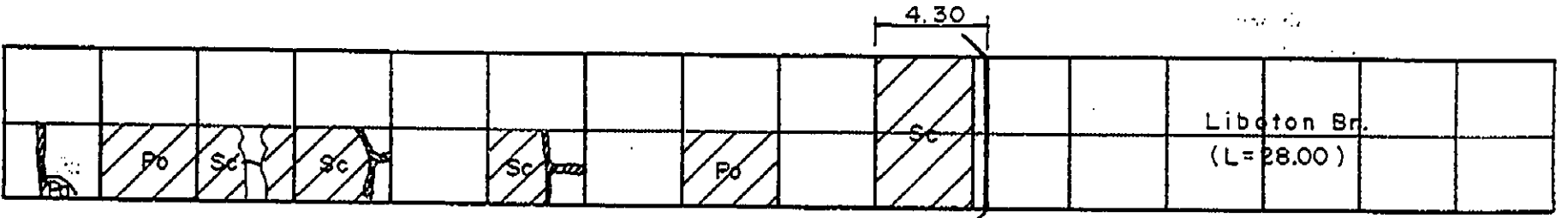
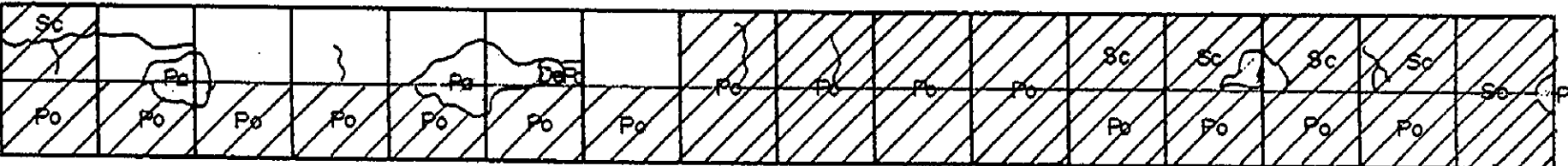
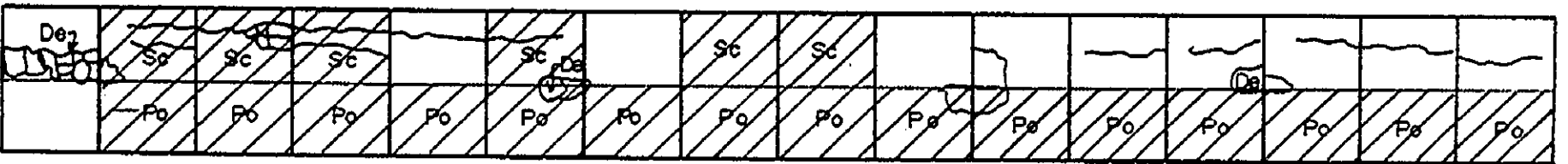
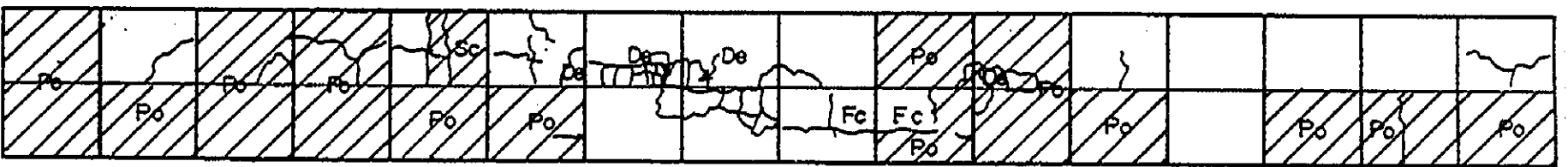
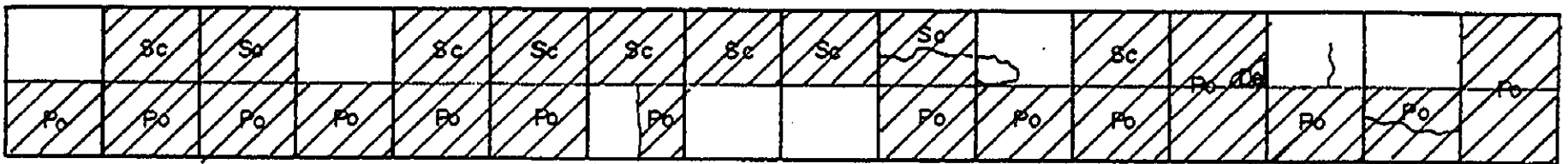
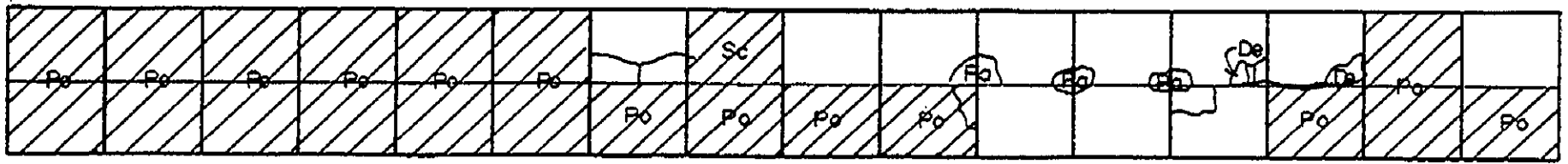

0.40 | 4.10 | 1.50

☒ KP1393+000

INVENTORY OF PAVEMENT SURFACE CONDITION

Date: 10-28-95

Sheet No: 1/2

Km. 1393+000

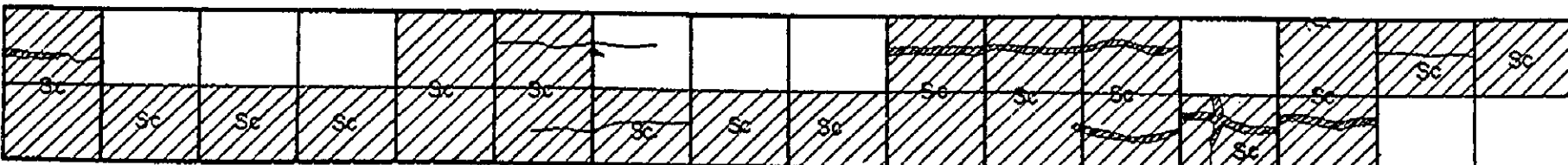
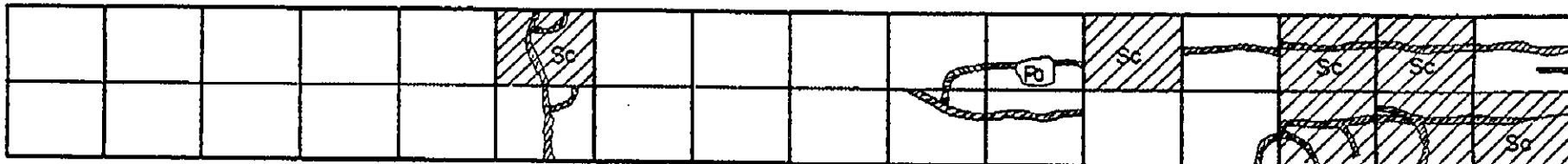
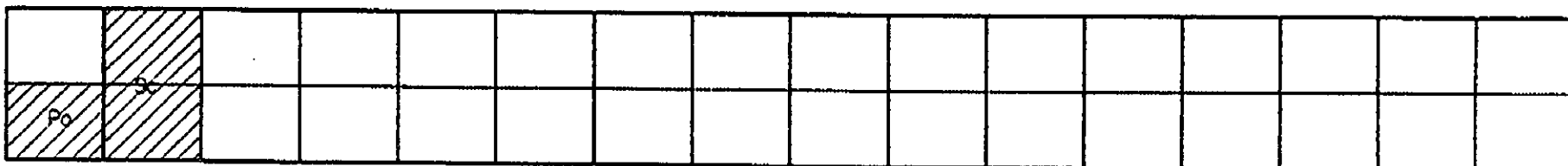
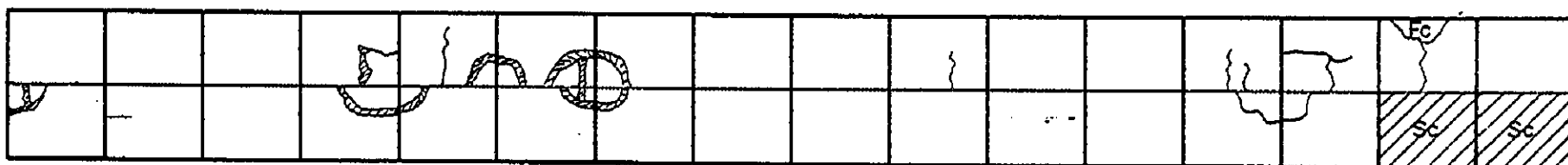
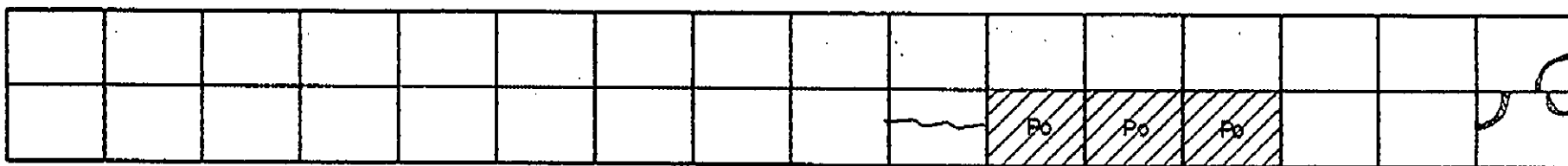
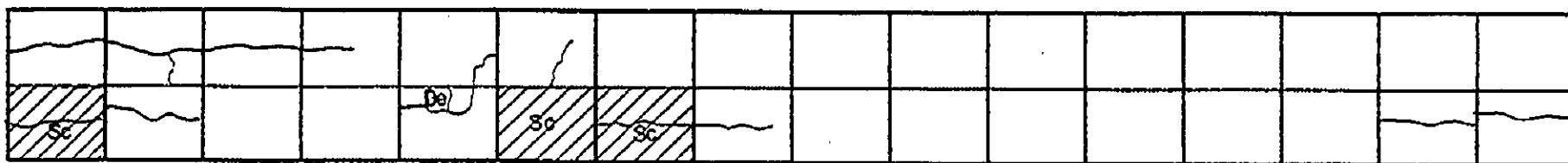
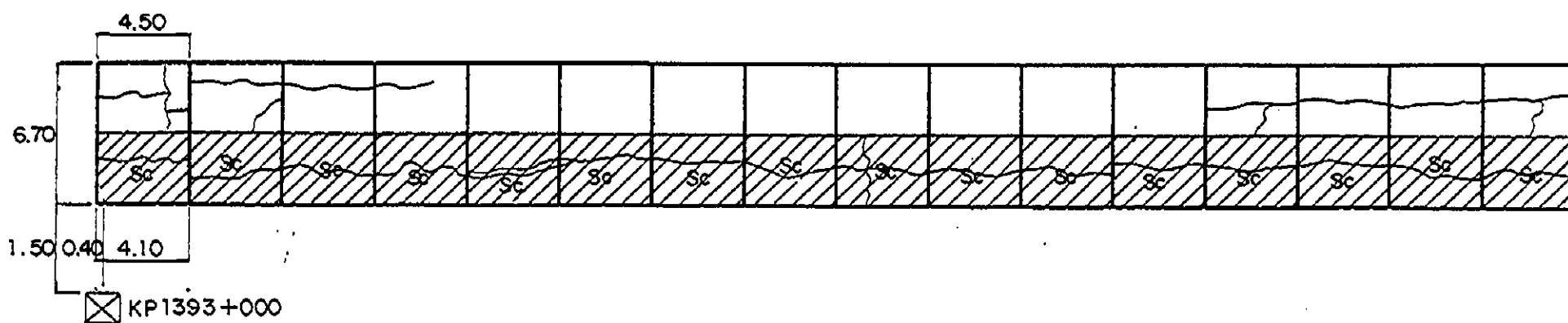

INVENTORY OF PAVEMENT SURFACE CONDITION

Km. 1393+000

Date: 10-28-95

Sheet No: 2/2

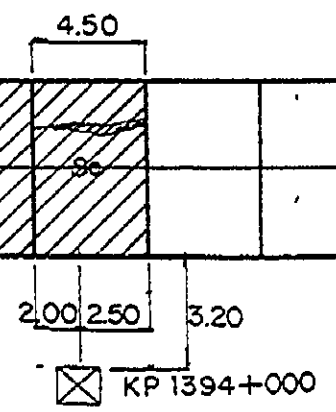
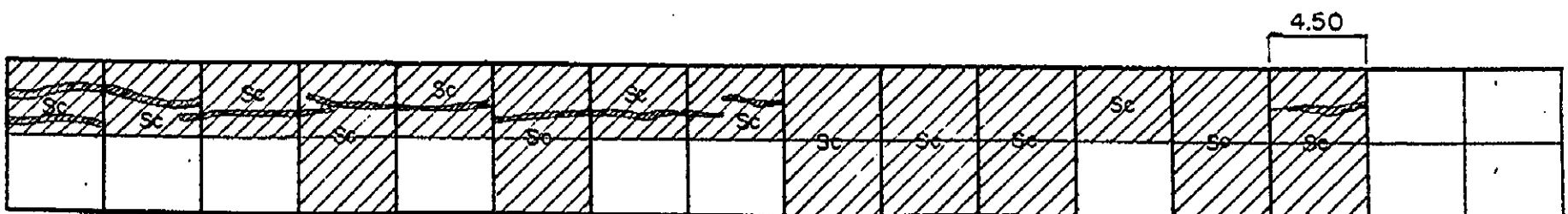
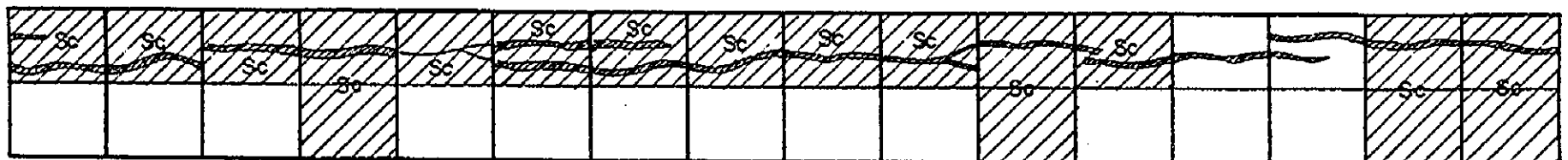
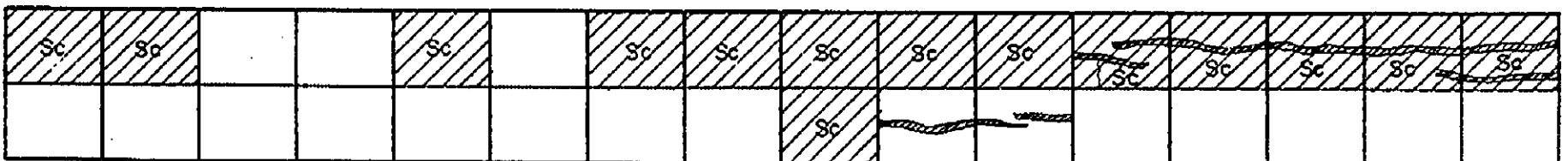
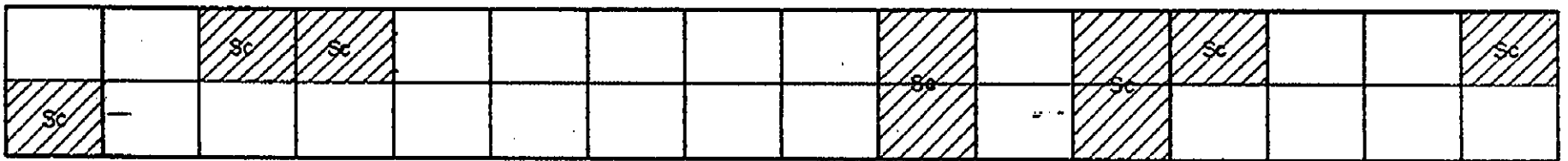
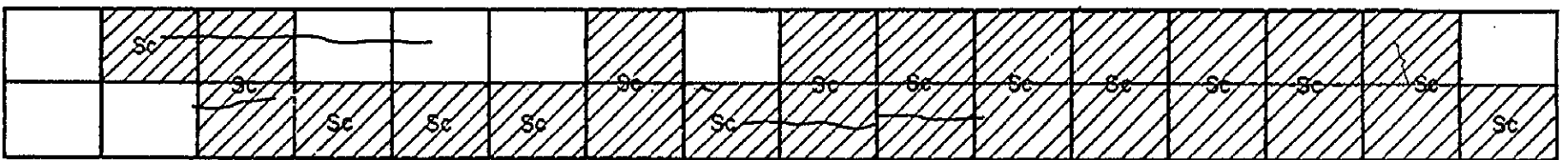
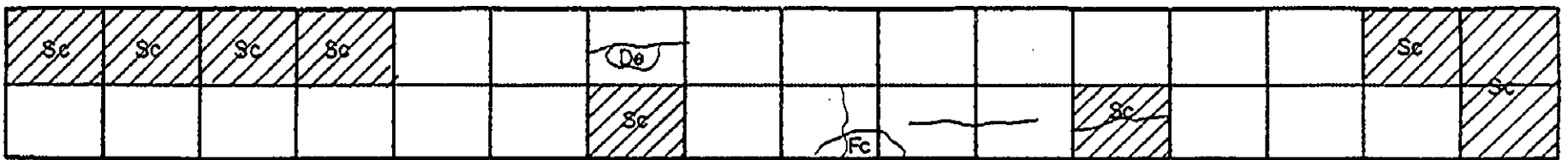
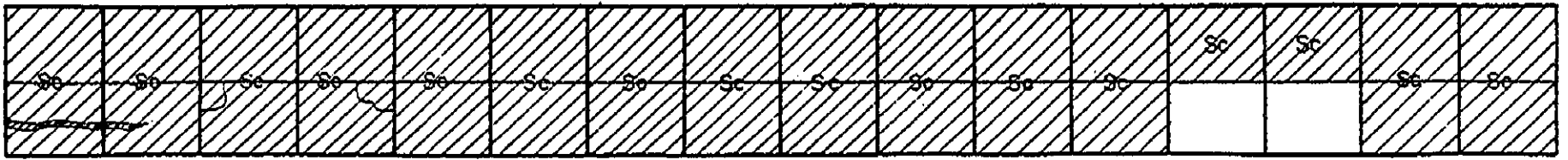

INVENTORY OF PAVEMENT SURFACE CONDITION

Date: 10-29-95

Sheet No: 1/2

Km. 1394+000

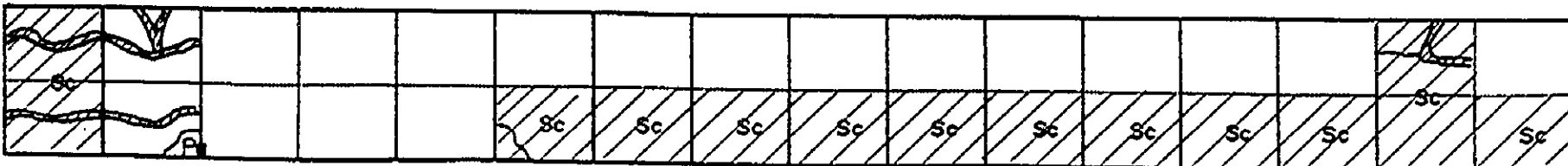
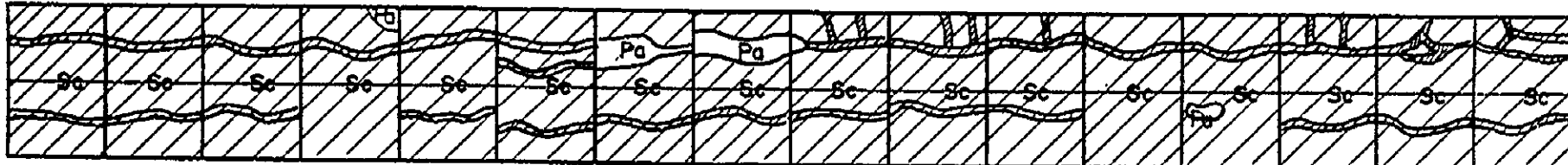
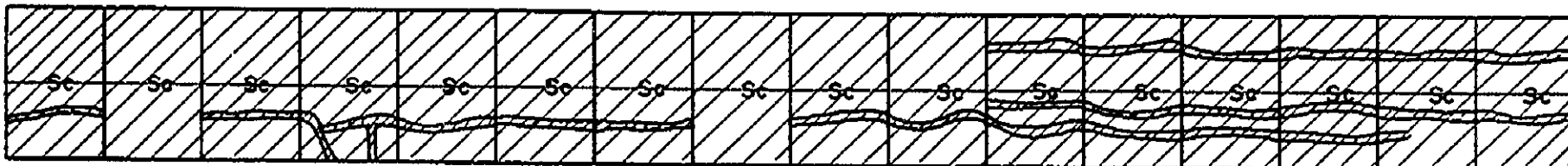
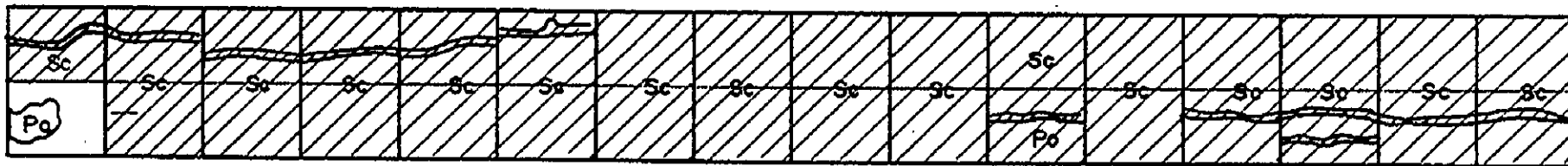
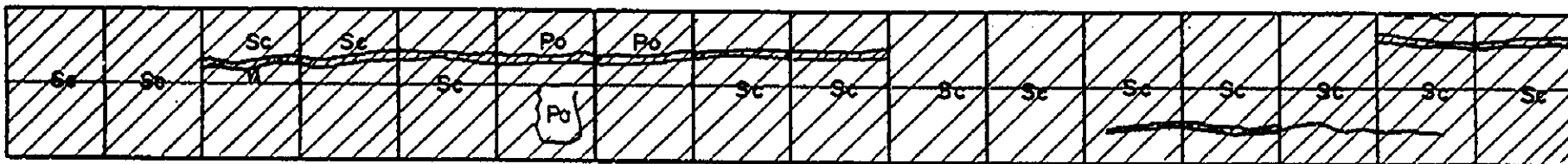
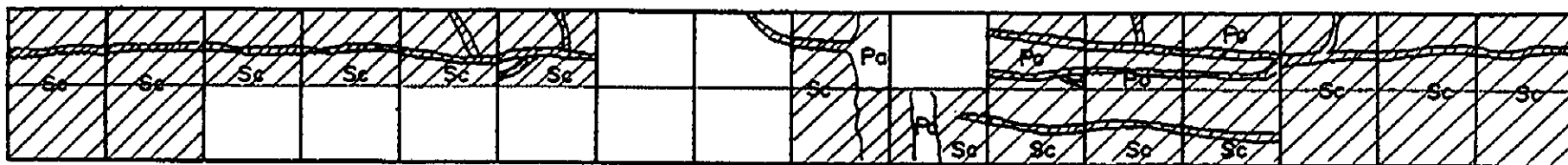
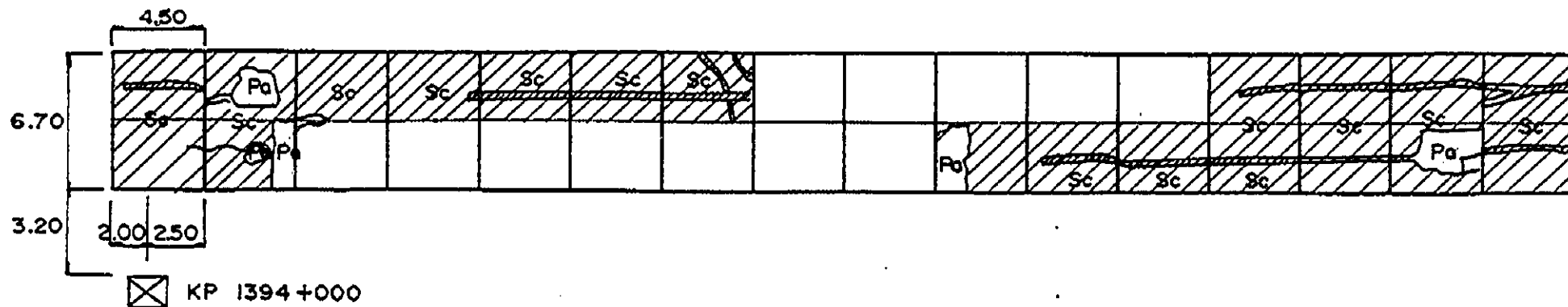

INVENTORY OF PAVEMENT SURFACE CONDITION

Km. 1394+000

Date: 10-29-95

Sheet No: 2/2

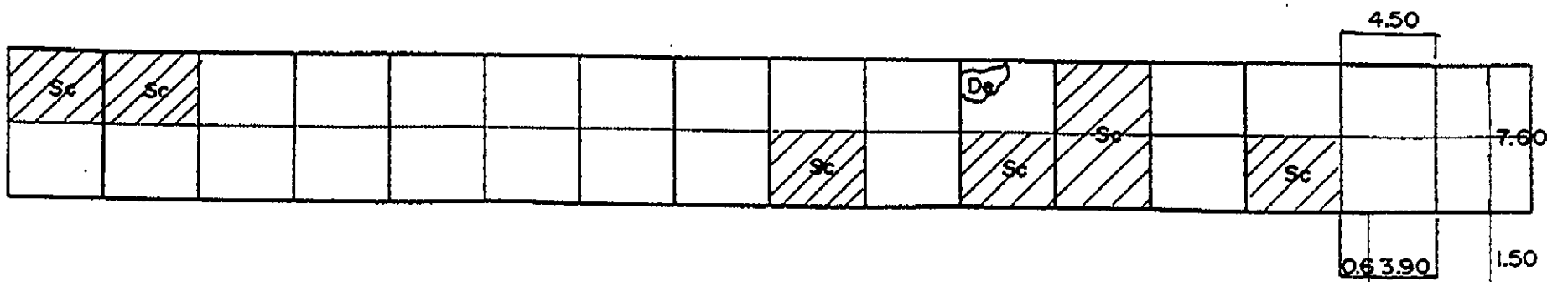
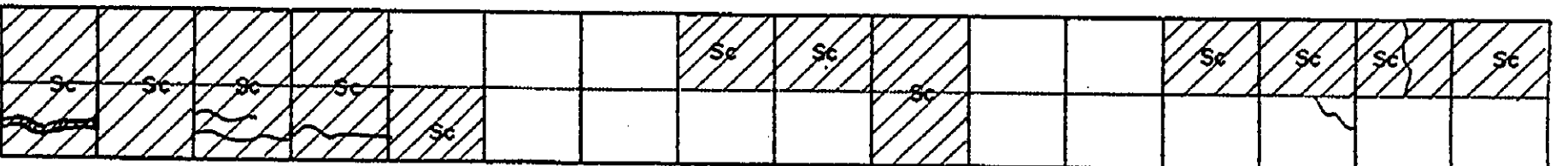
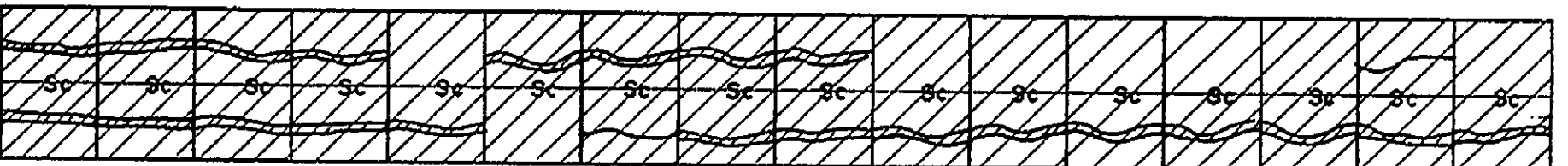
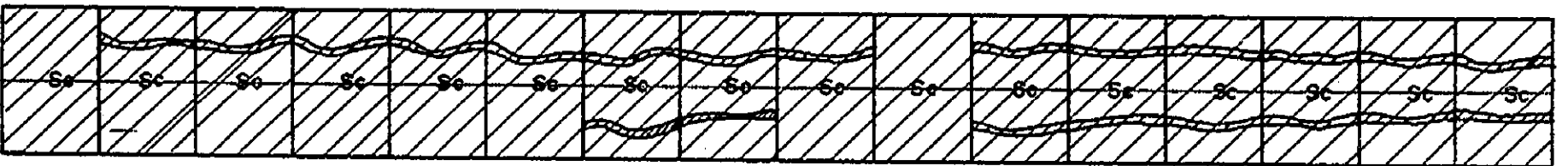
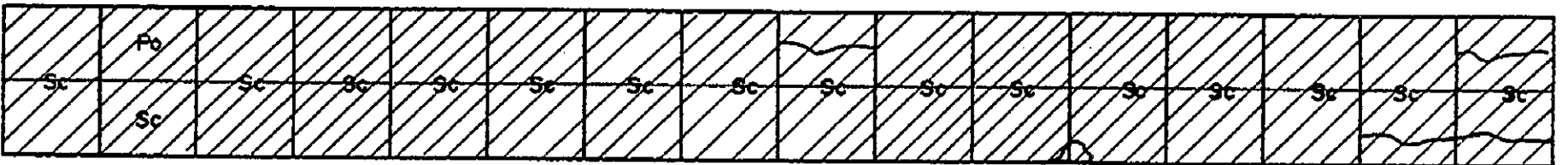
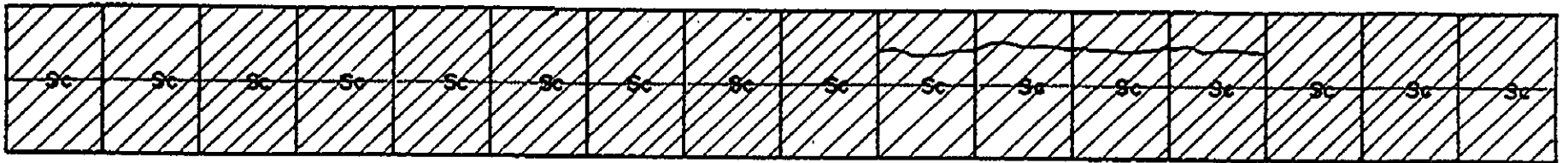
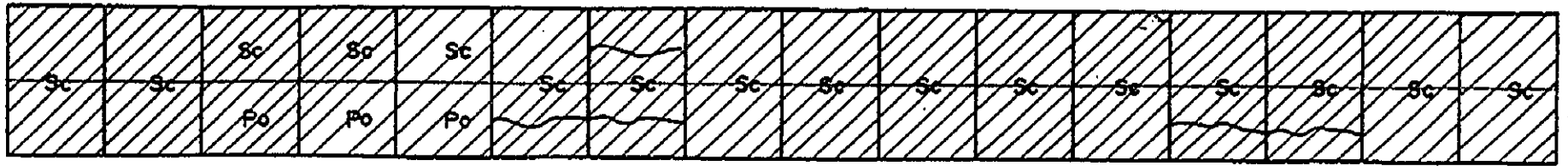

☒ KP 1395+000

INVENTORY OF PAVEMENT SURFACE CONDITION

Date : 10 - 29 - 95

Sheet No : 1/2

Km. 1395 + 000

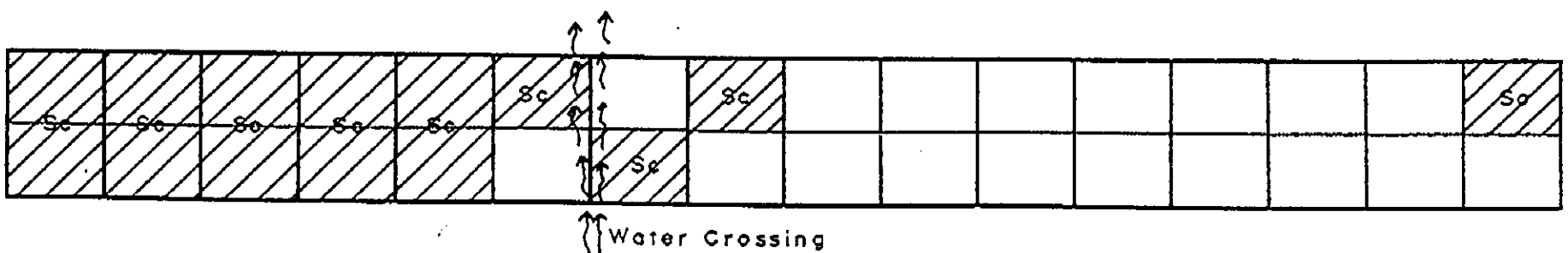
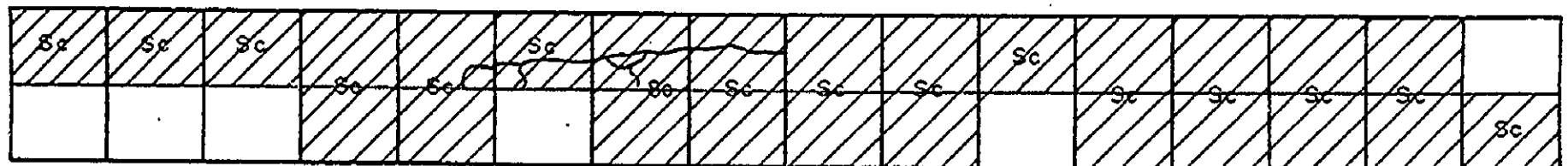
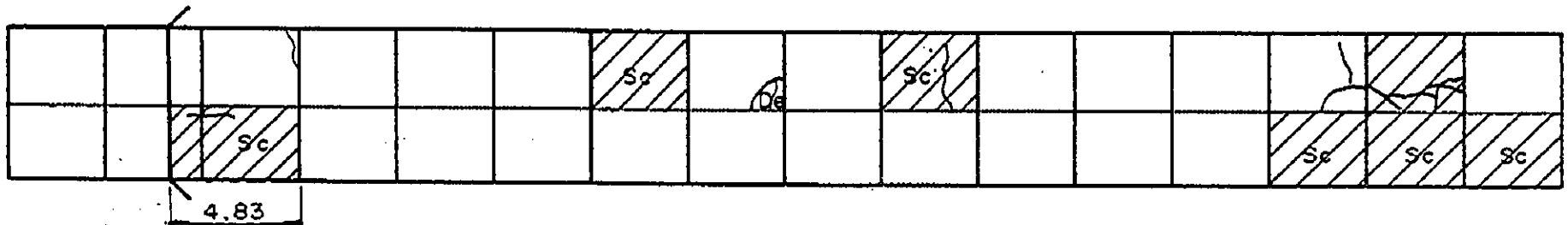
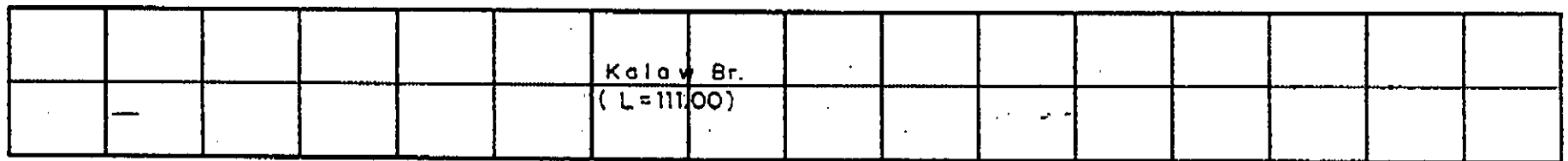
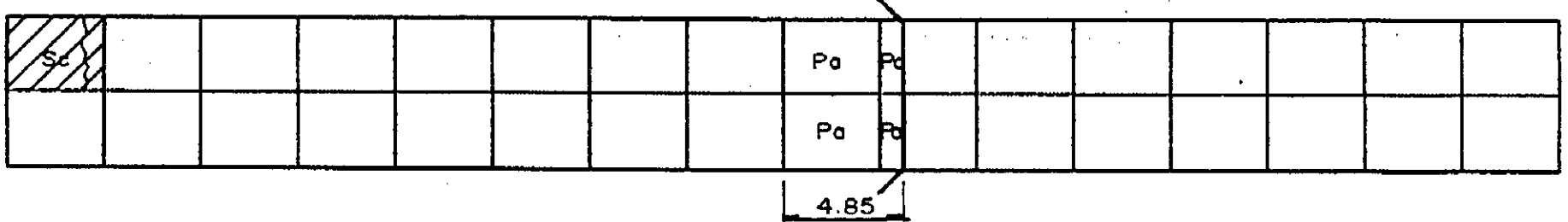
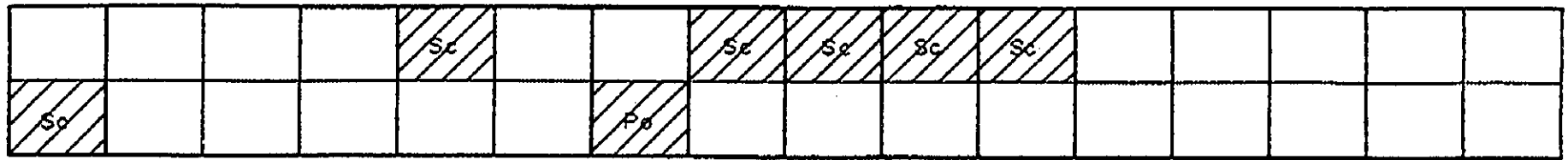
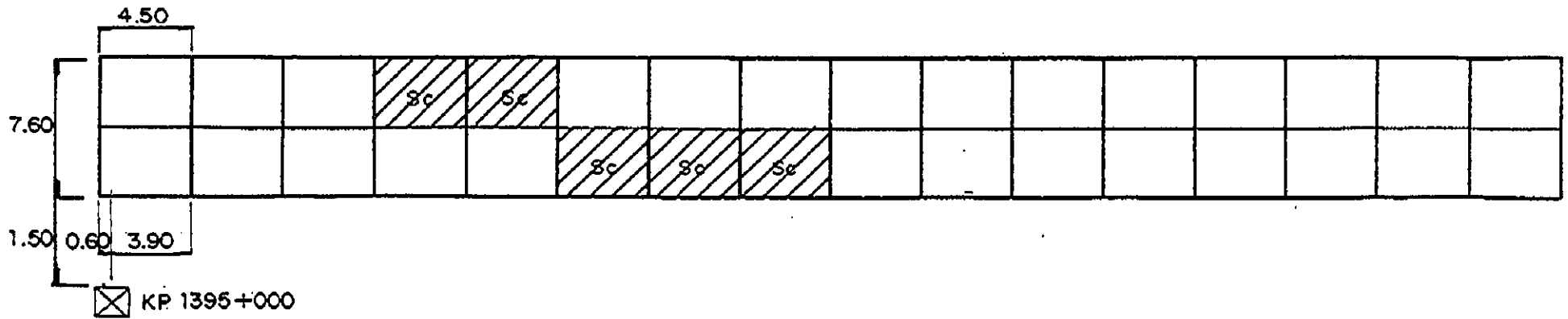

INVENTORY OF PAVEMENT SURFACE CONDITION

Km. 1395 + 000

Date: 10-29-95

Sheet No: 2/2

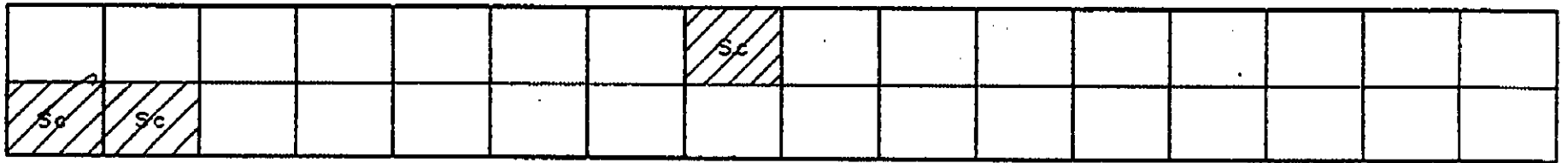
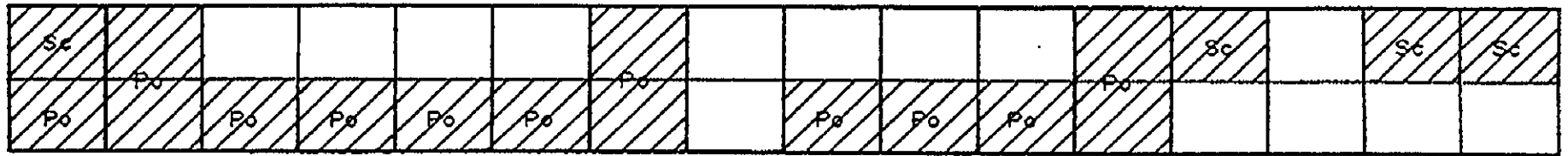
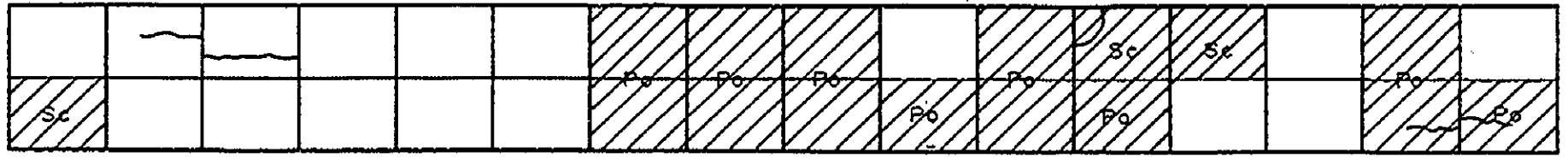

└─ Fc through Center line Joint
└─ Eroded Shoulder

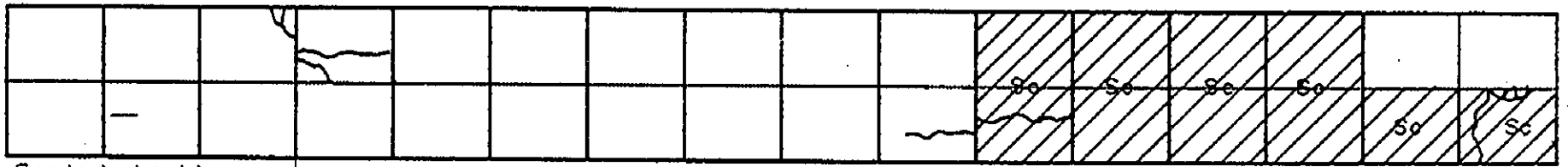

Eroded shoulder ────┐
└─ Fc through center line joint

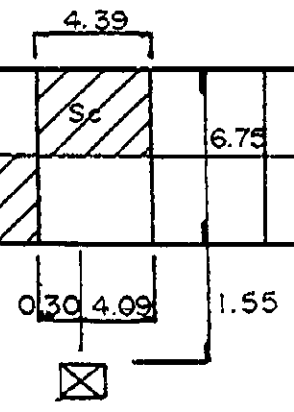
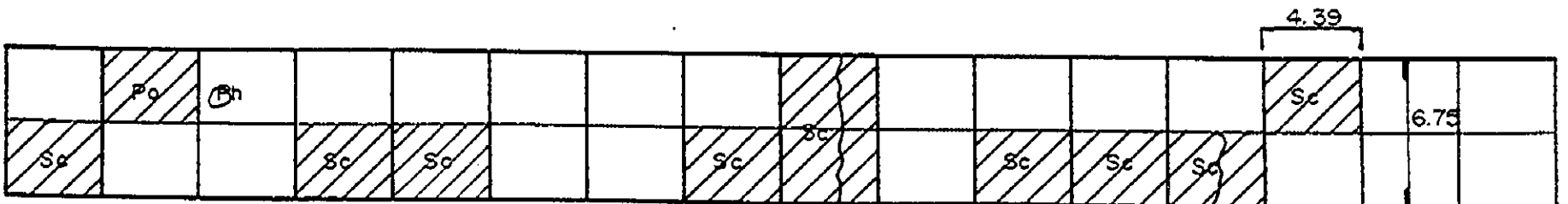
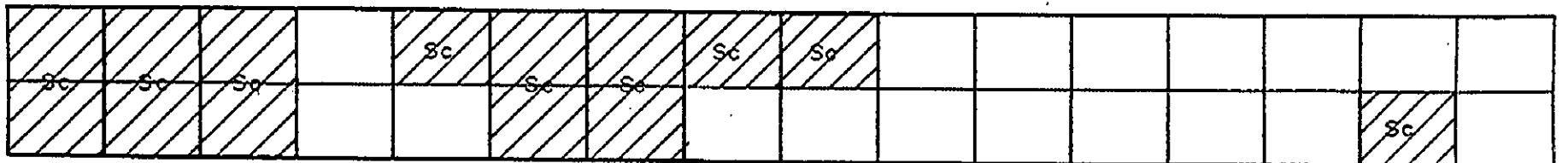
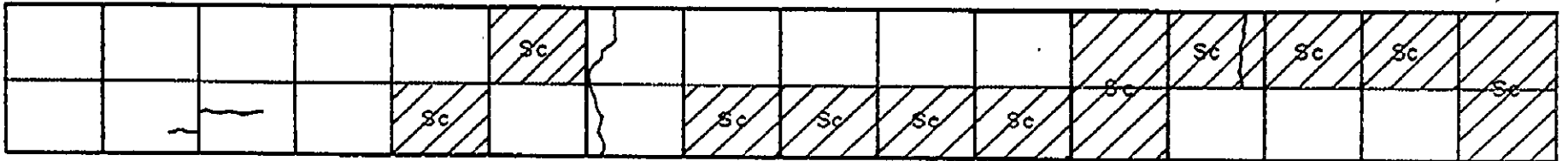

PAN-PHILIPPINE HIGHWAY IMPROVEMENT PROJECT
(MINDANAO SECTION)

PAVEMENT DISTRESS SURVEY
PACKAGE 15
Km.1396+000 - Km.1425+000

DECEMBER , 1996

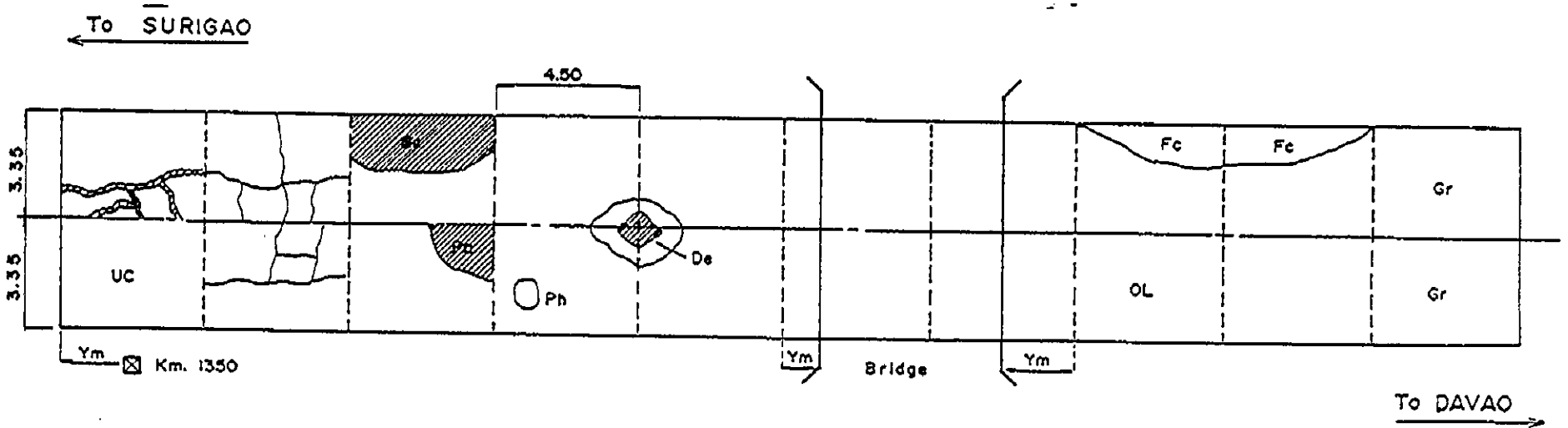

LEGENDS :

- | | | |
|------------------------------|-------------------|--|
| 1. Cracks | Open Cracks ——— | 8. Overlay —OL |
| | Sealed Cracks ——— | (Sketch area of pavement with overlay) |
| 2. Potholes — Ph | | 9. Under Construction - UC |
| 3. Patching — Pa | | 10. Gravel —Gr |
| 4. Cracks with Faulting — Fc | | (Except Under Construction) |
| 5. Scaling — Sc | | 11. Other Information |
| 6. Depression — De | | • Kilometer Post |
| 7. Pop out — Po | | • Bridge |

FIGURE 2.1-1 LEGENDS USED FOR SKETCHING PAVEMENT DISTRESS

INVENTORY OF PAVEMENT SURFACE CONDITION

Date : 10-29-95

Km. 1396 + 000 & 1397 + 000

Sheet No : 1/5

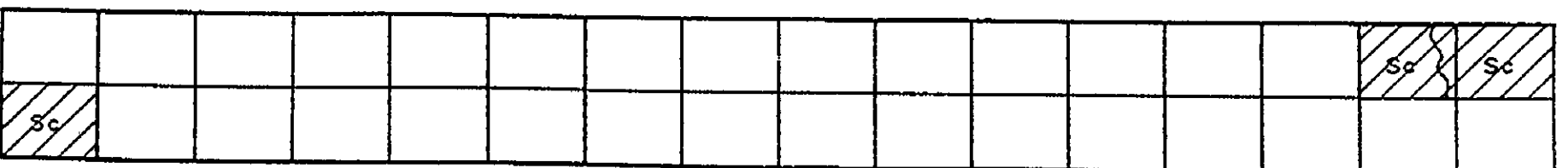
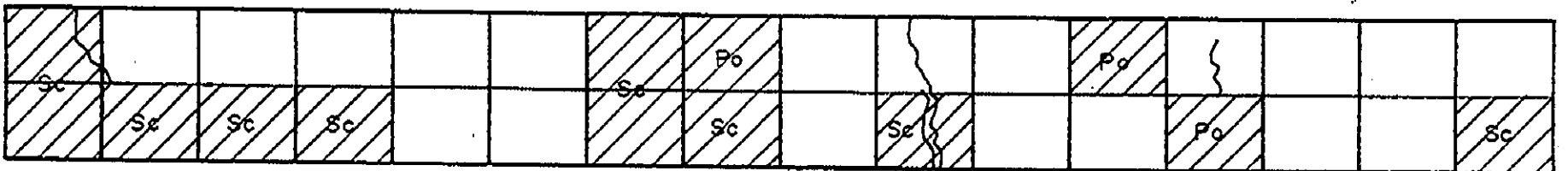
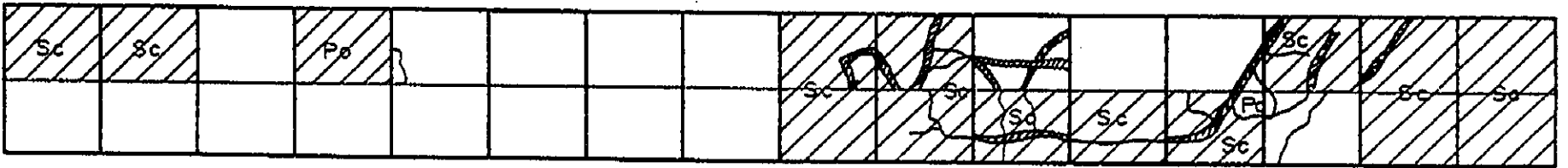
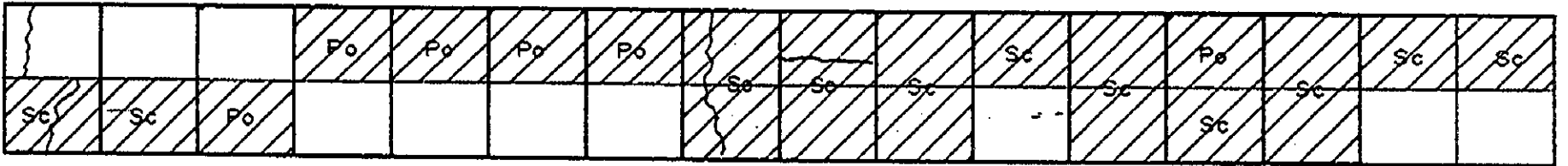
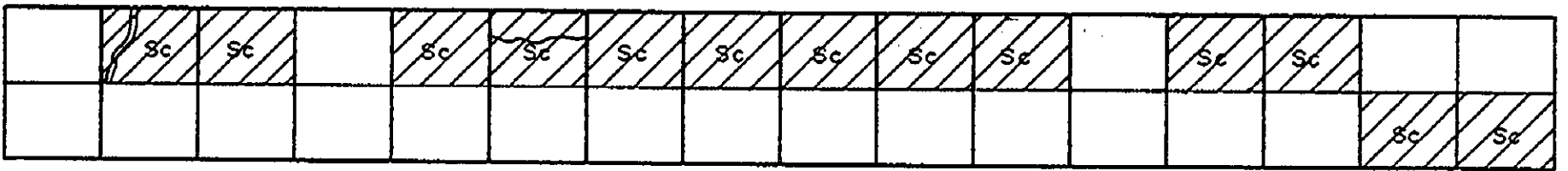
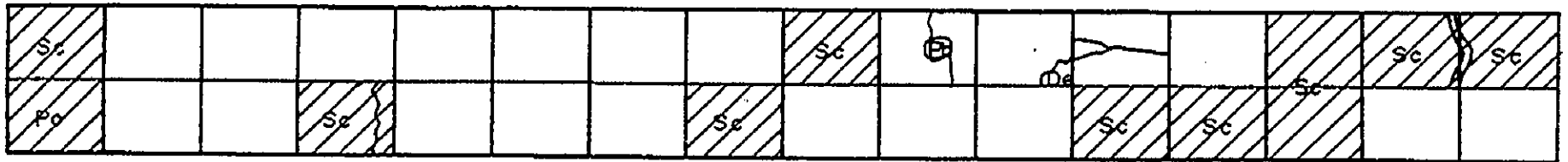
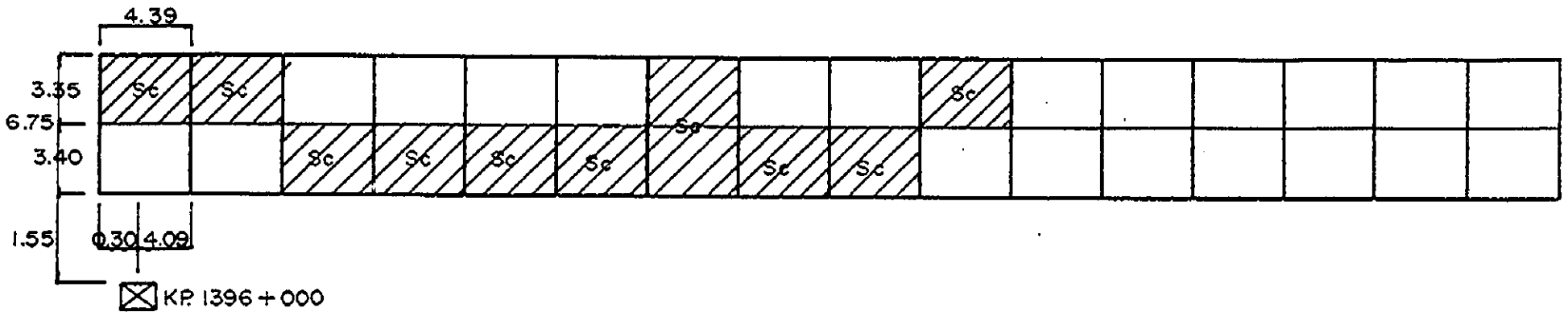

INVENTORY OF PAVEMENT SURFACE CONDITION

Date : 10-29-95

Km. 1396+000 & 1397+000

Sheet No : 3/5

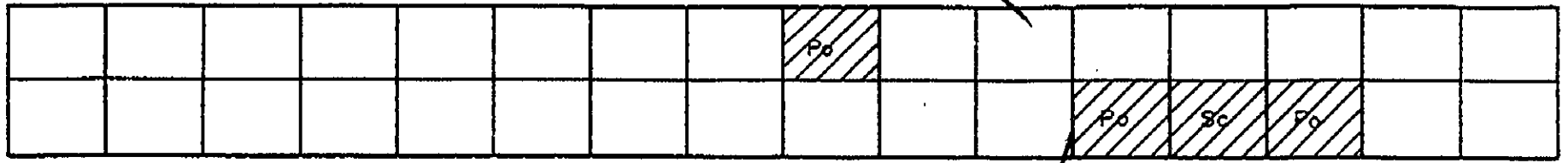

☒ KP. 1397+000
(Fallen KM.)

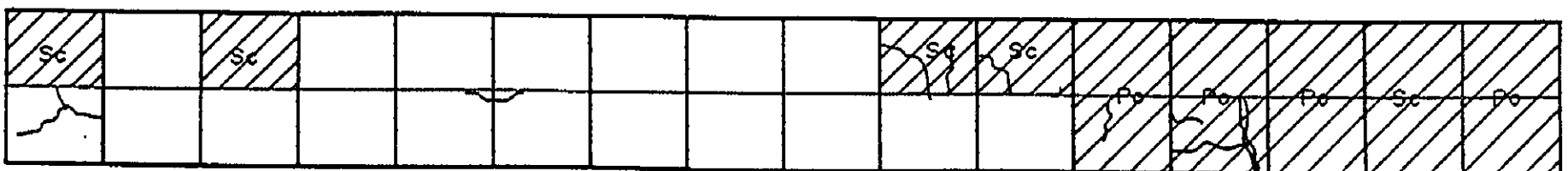
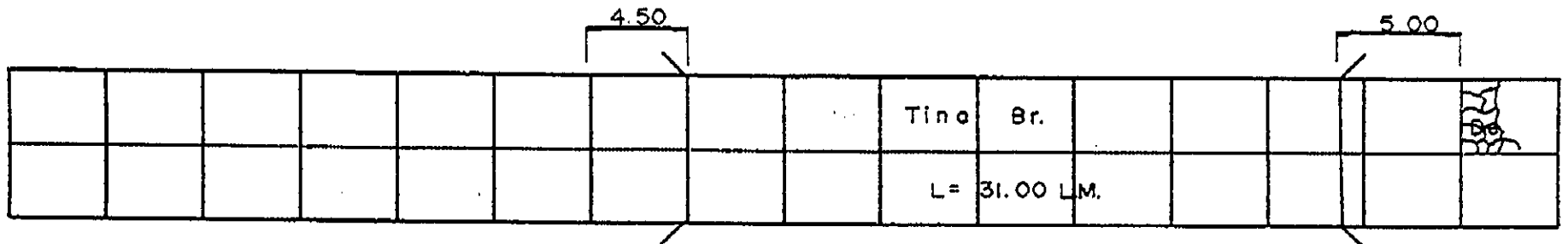
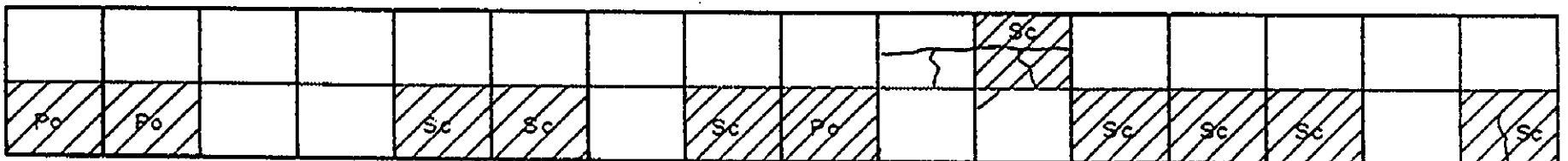
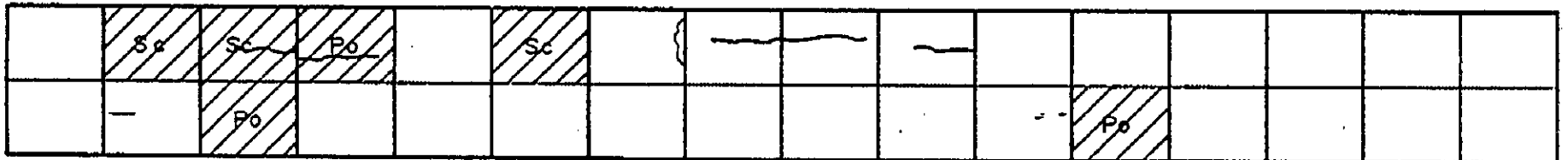
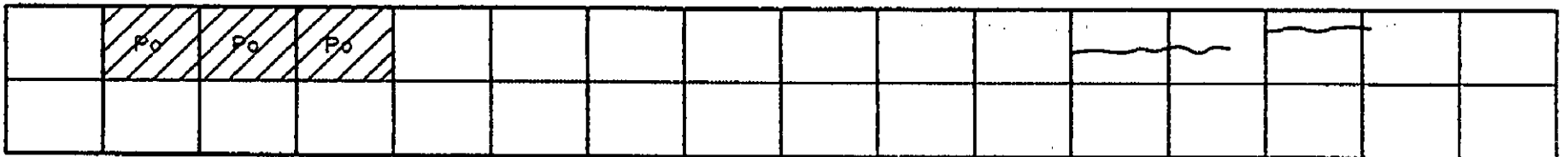
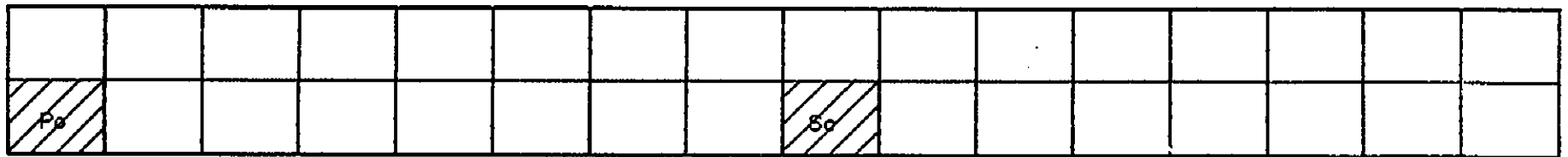

INVENTORY OF PAVEMENT SURFACE CONDITION

Km. 1396 + 000 a 1397 + 000

Date : 10 - 29 - 95

Sheet No : 4/5

| | | | | | | | | | | | | | | |
|--|--|----|--|--|----|----|----|--|--|--|----|--|--|--|
| | | Sc | | | Po | Sc | Sc | | | | Po | | | |
| | | | | | | | | | | | | | | |

| | | | | | | | | | | | | | | |
|----|--|----|--|--|--|--|----|--|--|--|--|--|--|--|
| Po | | | | | | | | | | | | | | |
| | | Po | | | | | Sc | | | | | | | |

| | | | | | | | | | | | | | | |
|--|----|----|--|--|-------|--|--|----|--|--|----|--|--|--|
| | | Po | | | De Sc | | | Sc | | | Po | | | |
| | Sc | | | | | | | | | | | | | |

| | | | | | | | | | | | | | | |
|--|---|----|--|--|----|--|-------|--|----|----|--|--|--|--|
| | | Po | | | Sc | | De Sc | | | | | | | |
| | - | | | | | | Sc | | Po | Po | | | | |

| | | | | | | | | | | | | | | |
|--|--|--|--|--|--|--|----|--|--|--|----|----|----|--|
| | | | | | | | | | | | De | Po | Sc | |
| | | | | | | | De | | | | | | | |

| | | | | | | | | | | | | | | |
|----|--|----|--|--|--|--|--|--|--|--|--|----|----|--|
| | | | | | | | | | | | | Sc | Sc | |
| Po | | Po | | | | | | | | | | | | |

| | | | | | | | | | | | | | | |
|----|--|----|----|----|-------|----|--|--|--|--|--|--|----|--|
| | | Sc | Sc | De | De Sc | | | | | | | | Sc | |
| Sc | | Po | | | | Po | | | | | | | | |

INVENTORY OF PAVEMENT SURFACE CONDITION

Date: 10-29-95

Sheet No: 1/2

Km. 1398+000

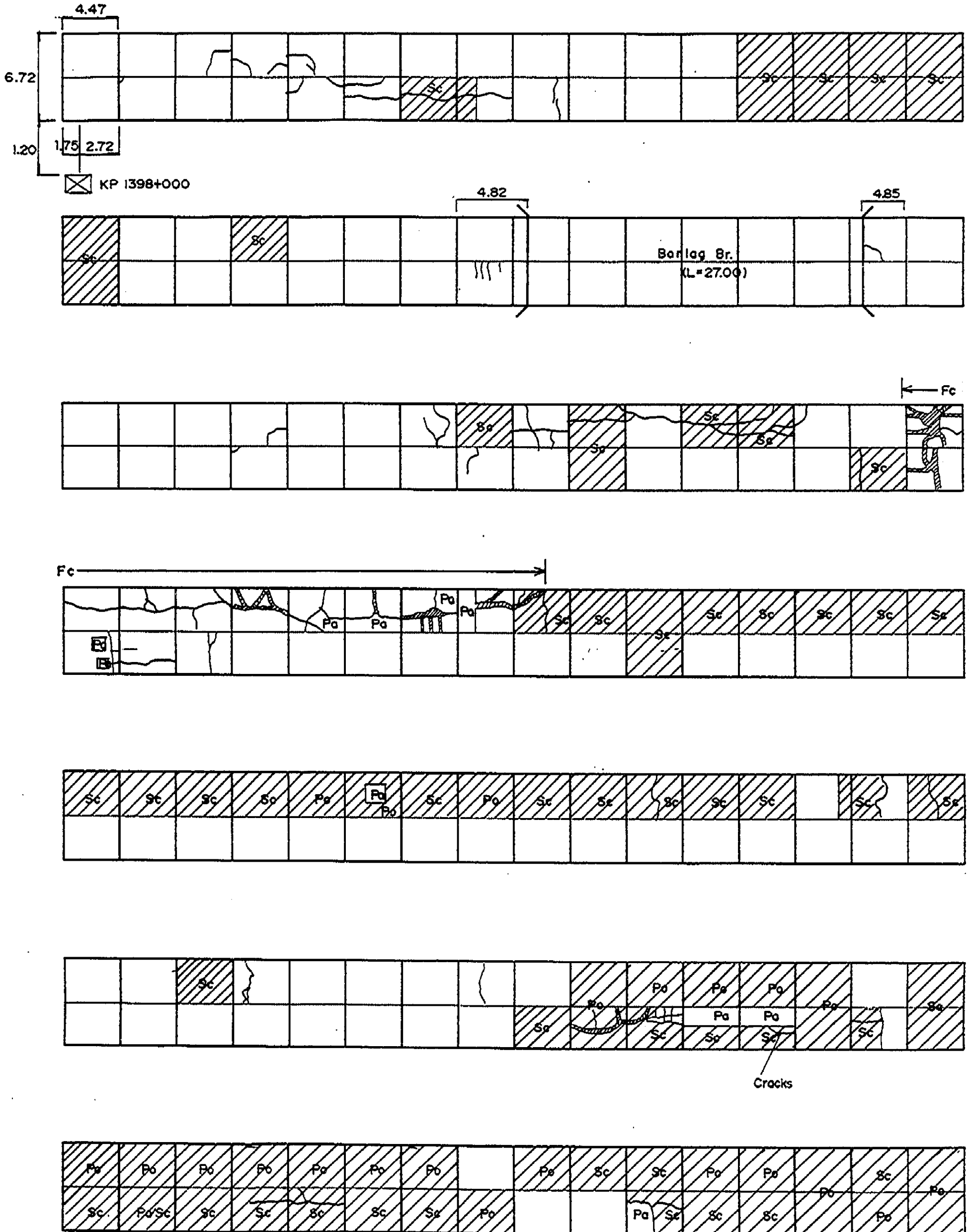

INVENTORY OF PAVEMENT SURFACE CONDITION

Date: 10-29-95

Km. 1398+000

Sheet No: 2/2

| | | | | | | | | | | | | | | | | | |
|----|----|----|----|----|----|----|----|----|----|----|----|----|----|----|----|----|----|
| / | / | / | / | / | Po | / | / | / | / | / | / | / | / | / | / | Po | Po |
| Po | Po | Po | Po | Po | Sc | Sc | Sc | Sc | Sc | Sc | Sc | Sc | Sc | Sc | Sc | Sc | Sc |

| | | | | | | | | | | | | | | | | | |
|----|----|----|----|----|----|----|----|----|----|----|----|----|----|----|----|----|----|
| / | / | / | / | / | / | / | / | / | / | / | / | / | / | / | / | / | / |
| Po | Po | Sc | Po | Po | Po | Po | Po | Po | Po | Po | Po | Po | Po | Po | Po | Po | Po |

| | | | | | | | | | | | | | | | | | |
|----|----|----|----|----|----|----|----|----|----|----|----|----|----|----|----|----|----|
| / | / | / | / | / | / | / | / | / | / | / | / | / | / | / | / | / | / |
| Po | Po | Po | Po | Po | Po | Po | Po | Po | Po | Po | Po | Po | Po | Po | Po | Po | Po |

| | | | | | | | | | | | | | | | | | |
|----|----|----|----|----|----|----|----|----|----|----|----|----|----|----|----|----|----|
| / | / | / | / | / | / | / | / | / | / | / | / | / | / | / | / | / | / |
| Po | Po | Po | Po | Po | Po | Po | Po | Po | Po | Po | Po | Po | Po | Po | Po | Po | Po |

| | | | | | | | | | | | | | | | | | |
|----|----|----|----|----|----|----|----|----|----|----|----|----|----|----|----|----|----|
| / | / | / | / | / | / | / | / | / | / | / | / | / | / | / | / | / | / |
| Po | Po | Po | Po | Sc | Po | Po | Po | Po | Po | Po | Po | Po | Po | Po | Po | Po | Po |

| | | | | | | | | | | | | | | | | | |
|----|----|----|----|----|----|----|----|----|----|----|----|----|----|----|----|----|----|
| / | / | / | / | / | / | / | / | / | / | / | / | / | / | / | / | / | / |
| Po | Po | Po | Po | Po | Po | Po | Po | Po | Po | Po | Po | Po | Po | Po | Po | Po | Po |

| | | | | | | | | | | | | | | | | | |
|----|----|----|----|----|----|----|----|----|----|----|----|----|----|----|----|----|----|
| / | / | / | / | / | / | / | / | / | / | / | / | / | / | / | / | / | / |
| Sc | Po | Po | Po | Sc | Sc | Po | Po | Sc | Sc | Sc | Po | Po | Po | Po | Po | Po | Po |

4.54
2.60 | 1.94
2.33

INVENTORY OF PAVEMENT SURFACE CONDITION

Date: 10-29-95

Sheet No: 1/2

Km. 1399+000

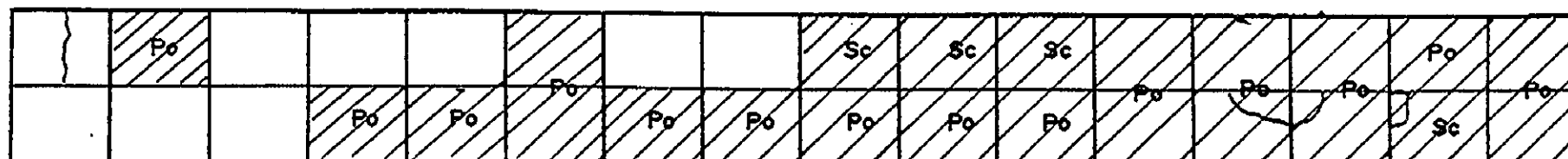
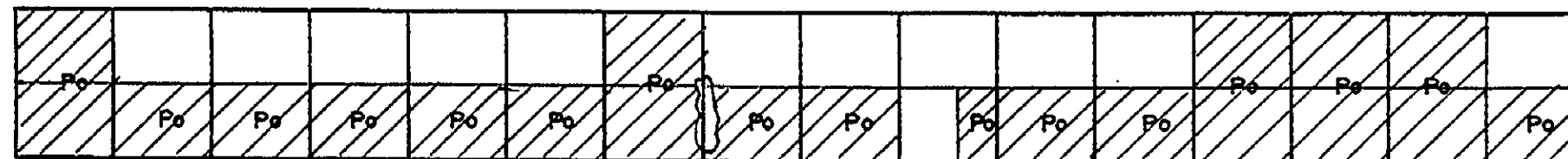
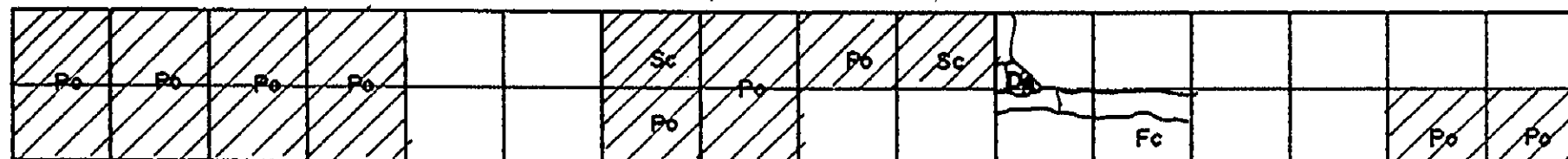
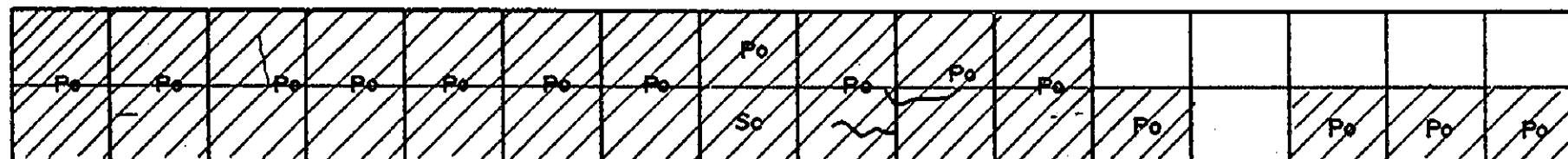
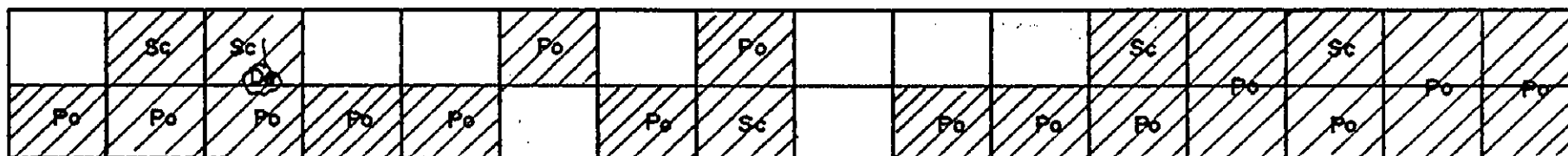
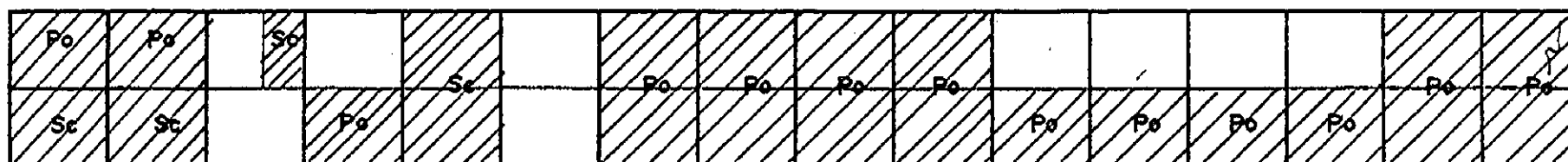
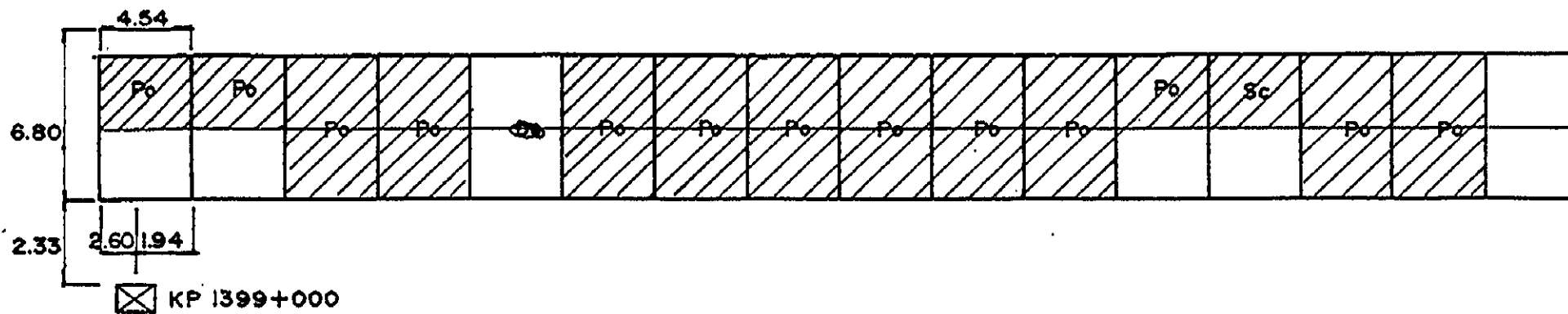

INVENTORY OF PAVEMENT SURFACE CONDITION

Date: 10-29-95

Km. 1399+000

Sheet No: 2/2

| | | | | | | | | | | | | | | | |
|--|----------------|----------------|----------------|----------------|----------------|----------------|----------------|----------------|----------------|----------------|----------------|----------------|----------------|----------------|----------------|
| | P _o | P _o | P _o | P _o | P _o | P _o | P _o | P _o | | P _o | P _o | | | | |
| | P _o | P _o | P _o | P _o | P _o | P _o | P _o | P _o | P _o | P _o | P _o | P _o | P _o | P _o | P _o |

| | | | | | | | | | | | | | | | |
|--|--|--|--|----------------|----------------|----------------|--|----------------|----------------|----------------|----------------|----------------|----------------|----------------|----------------|
| | | | | P _o | P _o | P _o | | P _o | P _o | P _o | P _o | P _o | | | |
| | | | | P _o | P _o | P _o | | P _o | P _o | P _o | P _o | P _o | P _o | P _o | P _o |

| | | | | | | | | | | | | | | | |
|----------------|----------------|----------------|----------------|----------------|----------------|----------------|----------------|----------------|----------------|----------------|----------------|----------------|----------------|----------------|----------------|
| P _o | P _o | P _o | P _o | P _o | P _o | P _o | P _o | P _o | P _o | P _o | P _o | P _o | P _o | P _o | P _o |
| P _o | P _o | P _o | P _o | P _o | P _o | P _o | P _o | P _o | P _o | P _o | P _o | P _o | P _o | P _o | P _o |

| | | | | | | | | | | | | | | | |
|----------------|----------------|----------------|----------------|----------------|----------------|----------------|----------------|----------------|----------------|----------------|----------------|----------------|----------------|----------------|----------------|
| P _o | P _o | P _o | P _o | P _o | P _o | P _o | P _o | P _o | P _o | P _o | P _o | P _o | P _o | P _o | P _o |
| P _o | P _o | P _o | P _o | P _o | P _o | P _o | P _o | P _o | P _o | P _o | P _o | P _o | P _o | P _o | P _o |

| | | | | | | | | | | | | | | | |
|----------------|----------------|----------------|----------------|----------------|----------------|----------------|----------------|----------------|----------------|----------------|----------------|----------------|----------------|----------------|----------------|
| P _o | P _o | P _o | P _o | P _o | P _o | P _o | P _o | P _o | P _o | P _o | P _o | P _o | P _o | P _o | P _o |
| P _o | P _o | P _o | P _o | P _o | P _o | P _o | P _o | P _o | P _o | P _o | P _o | P _o | P _o | P _o | P _o |

| | | | | | | | | | | | | | | | |
|----------------|----------------|----------------|----------------|----------------|----------------|----------------|----------------|----------------|----------------|----------------|----------------|----------------|----------------|----------------|----------------|
| P _o | P _o | P _o | P _o | P _o | P _o | P _o | P _o | P _o | P _o | P _o | P _o | P _o | P _o | P _o | P _o |
| P _o | P _o | P _o | P _o | P _o | P _o | P _o | P _o | P _o | P _o | P _o | P _o | P _o | P _o | P _o | P _o |

| | | | | | | | | | | | | | | | |
|----------------|----------------|----------------|----------------|----------------|----------------|----------------|----------------|----------------|----------------|----------------|----------------|----------------|----------------|----------------|----------------|
| P _o | | P _o | P _o | P _o | P _o | P _o | P _o | P _o | P _o | P _o | P _o | P _o | P _o | | |
| P _o | P _o | P _o | P _o | P _o | P _o | P _o | P _o | P _o | P _o | P _o | P _o | P _o | P _o | P _o | P _o |

4.50

6.76

3.70 0.80 1.65

☒ KP 1400+000

INVENTORY OF PAVEMENT SURFACE CONDITION

Date: 10-29-95

Sheet No: 1/2

Km. 1400 + 000

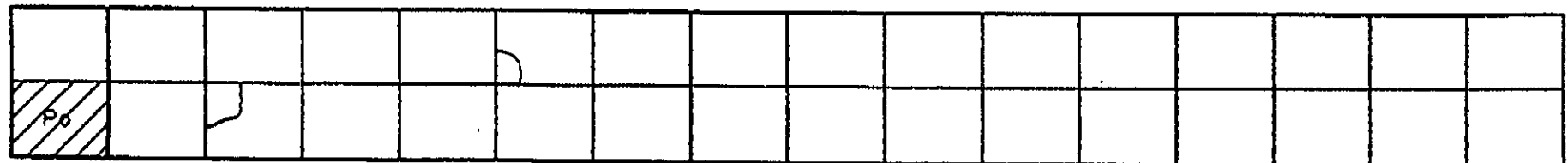
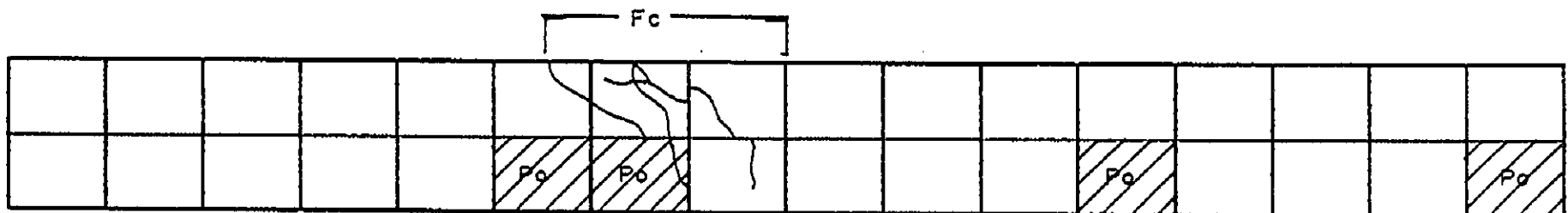
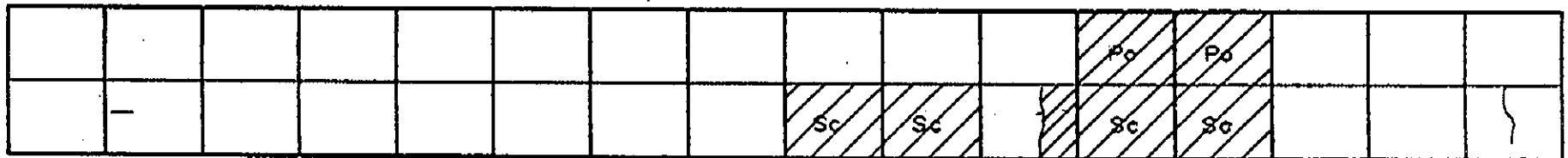
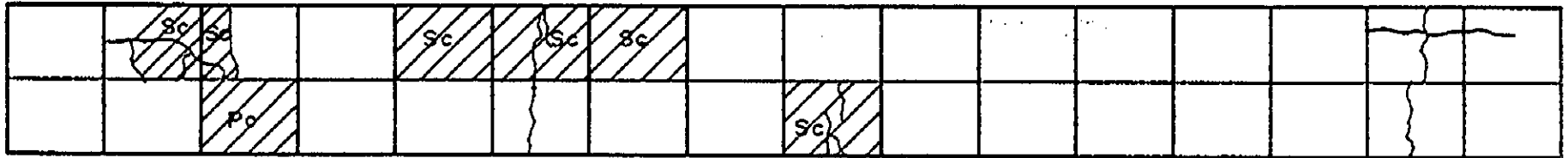
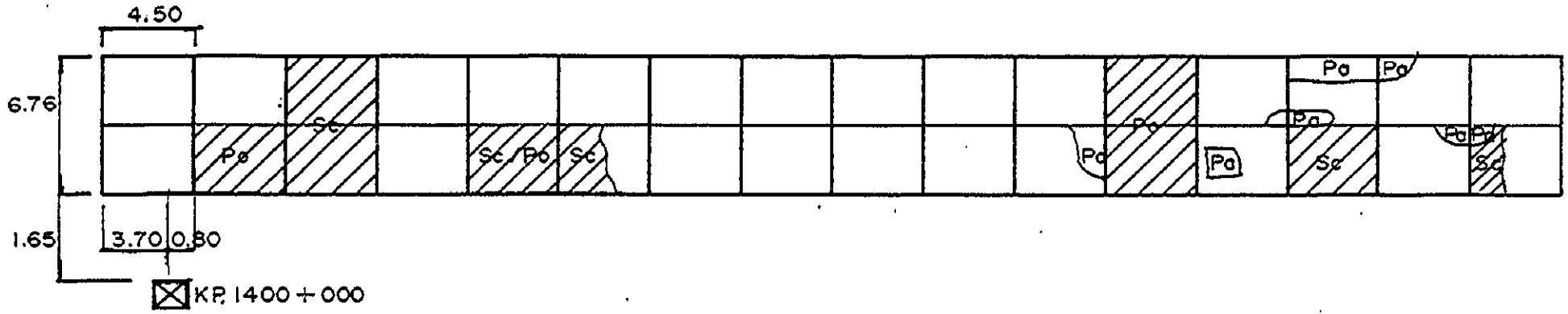

INVENTORY OF PAVEMENT SURFACE CONDITION

Date: 10-29-95

Sheet No: 2/2

Km. 1400+000

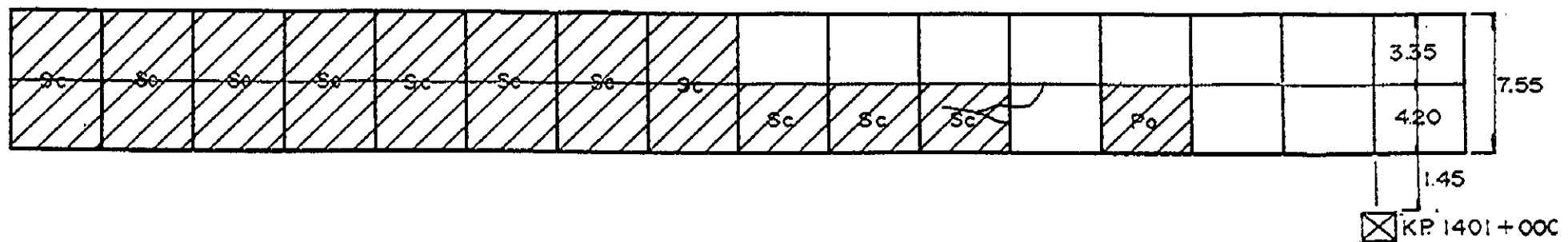
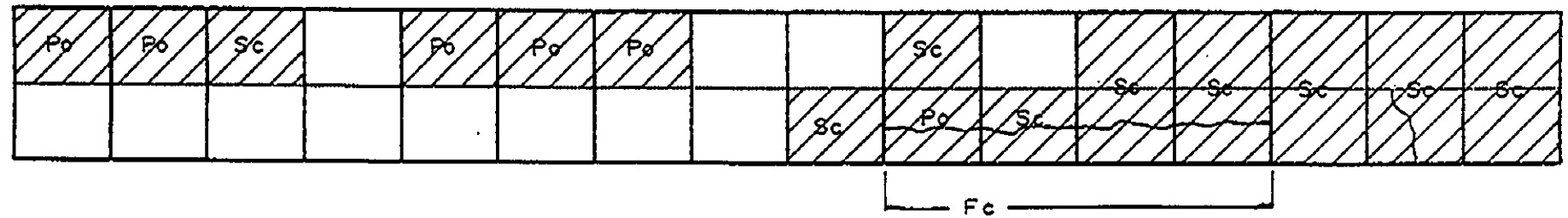
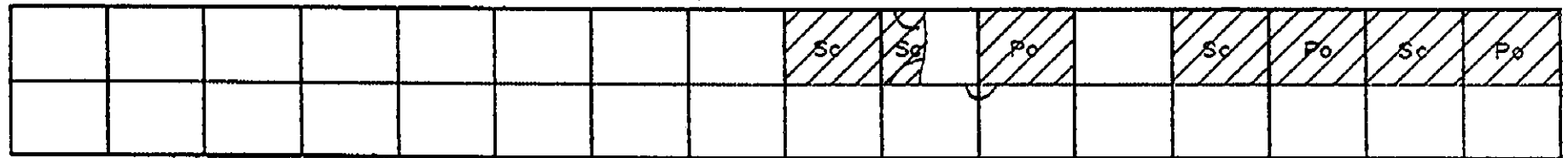
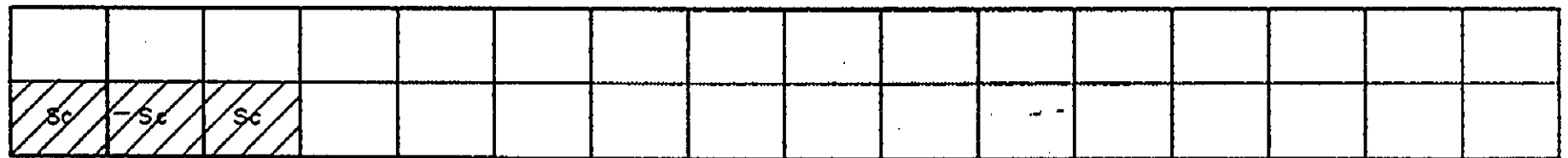
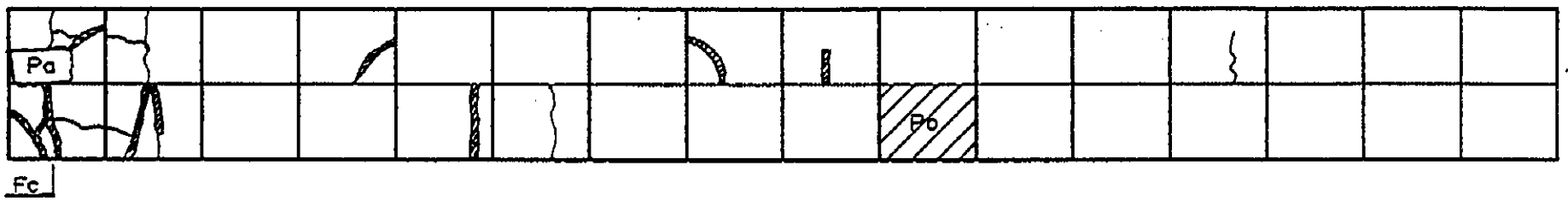
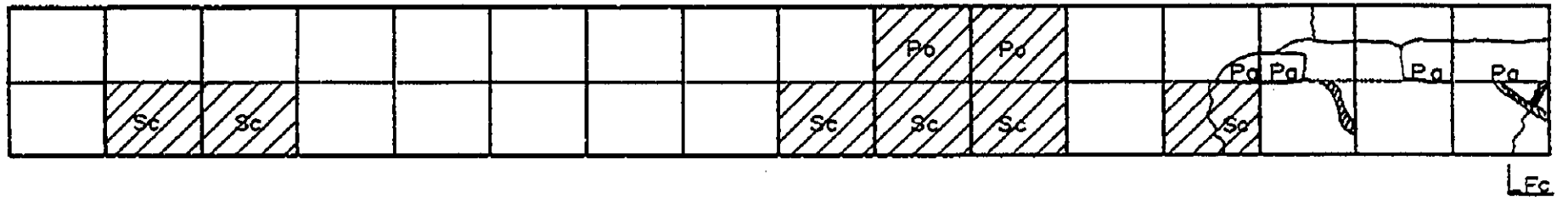
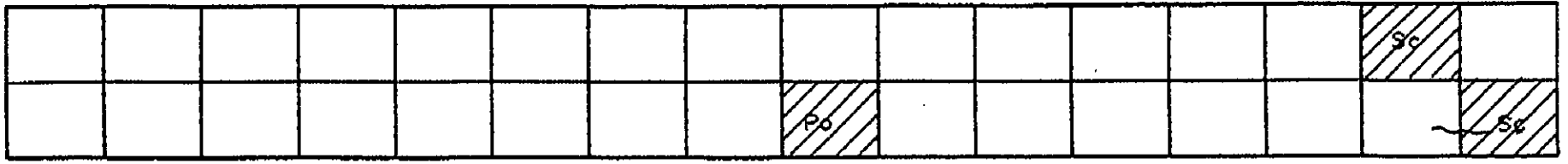

INVENTORY OF PAVEMENT SURFACE CONDITION

Date : 10-29-95

Km. 1401 + 000

Sheet No : 1/2

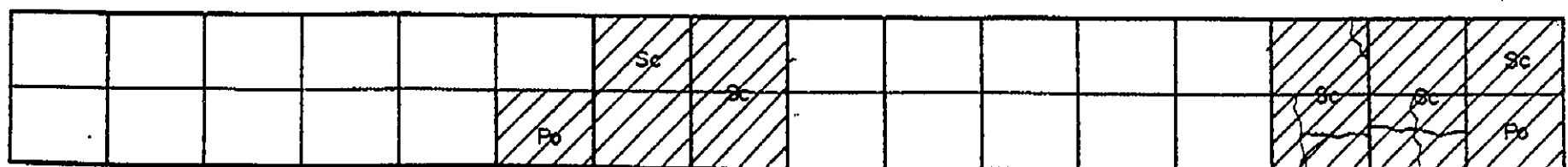
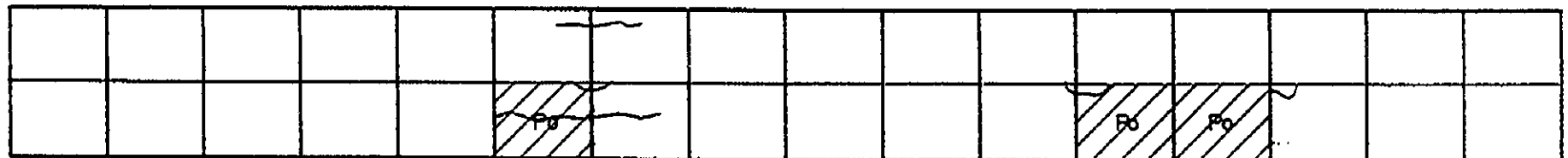
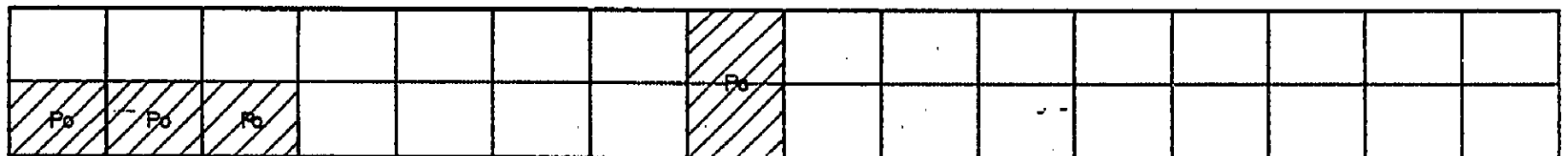
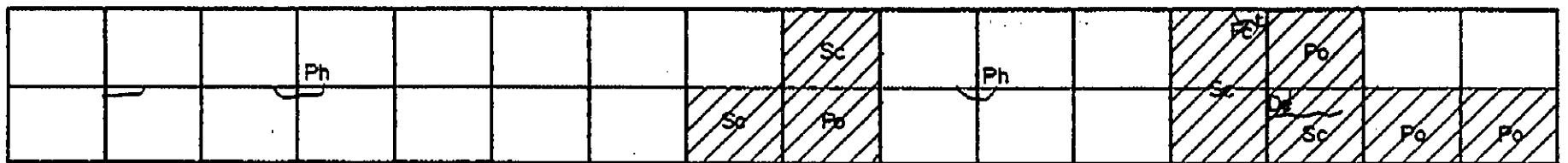
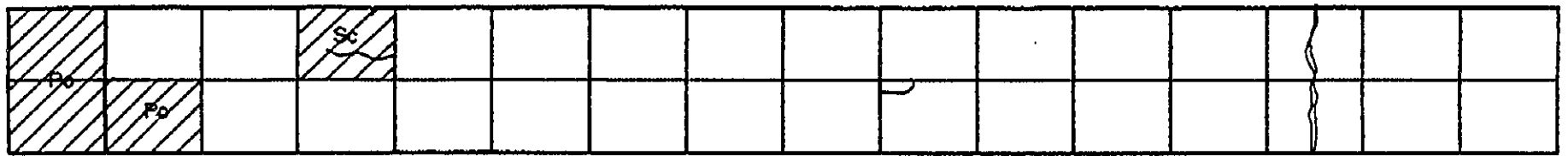
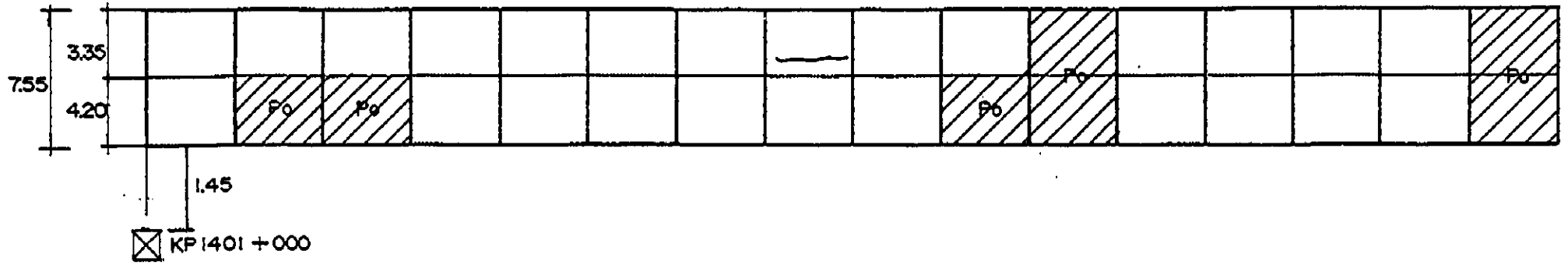

INVENTORY OF PAVEMENT SURFACE CONDITION

Date: 10-29-95

Km. 1401 + 000

Sheet No: 2/2

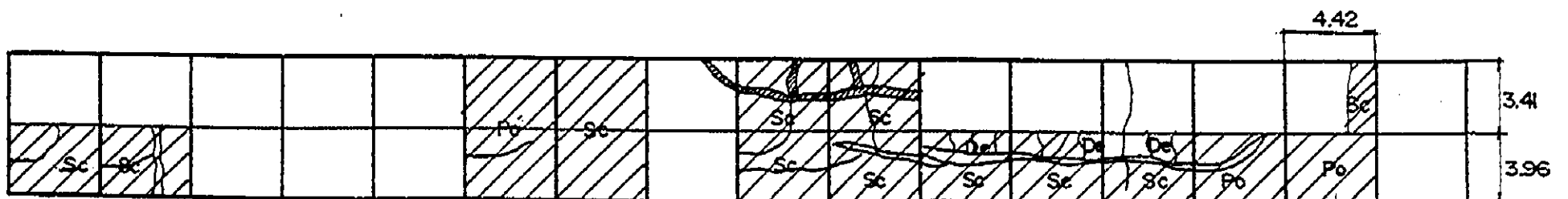
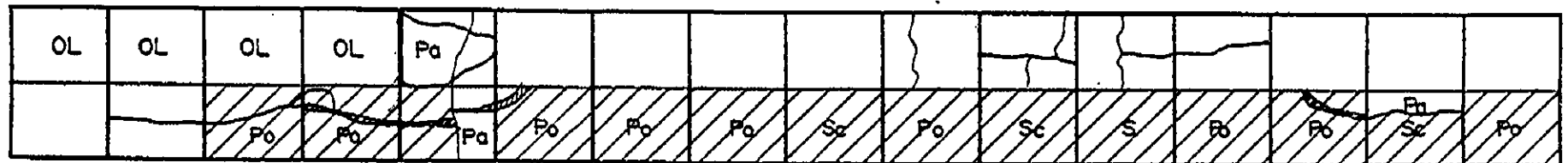
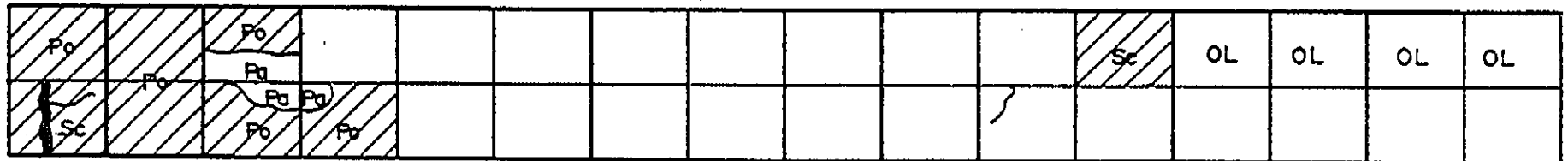
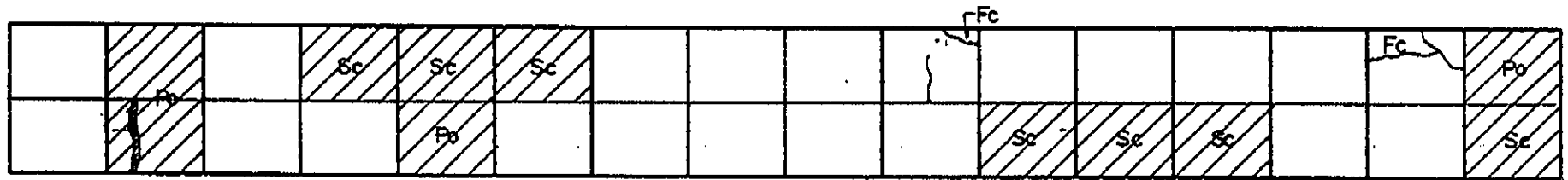
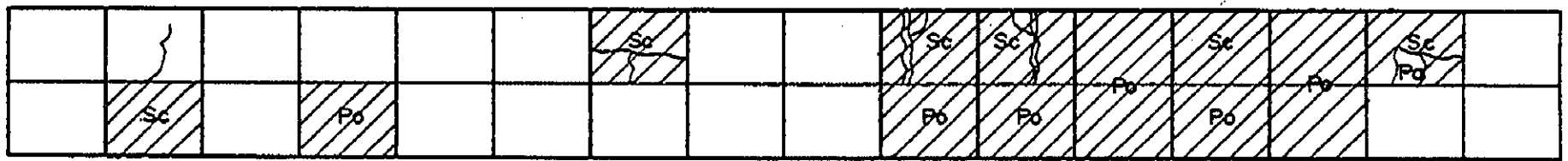
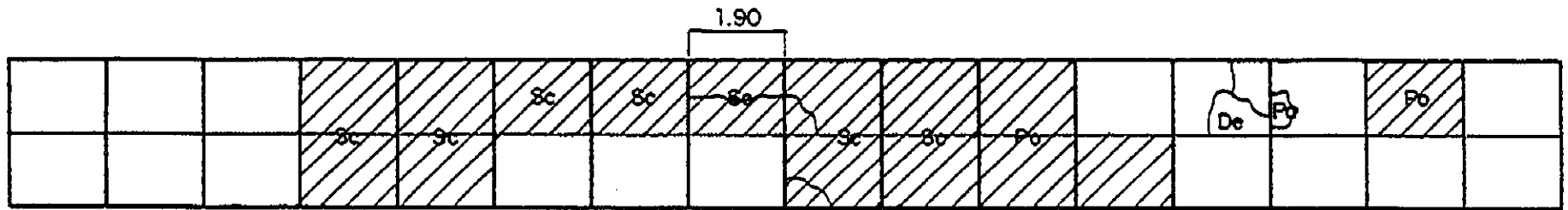
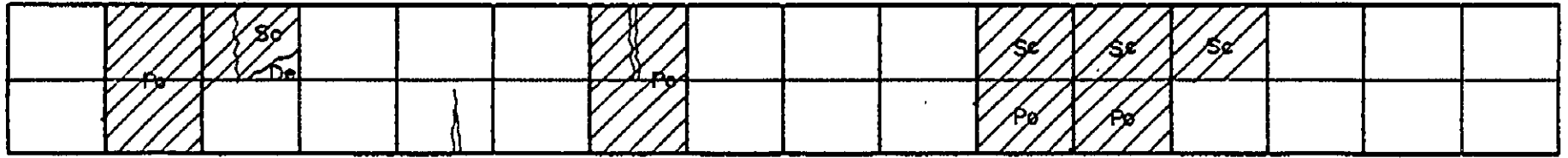

3.41
3.96
297.145 1.47
☒ KP1402+000

INVENTORY OF PAVEMENT SURFACE CONDITION

Date: 10-29-95

Sheet No: 1/2

Km. 1402+000

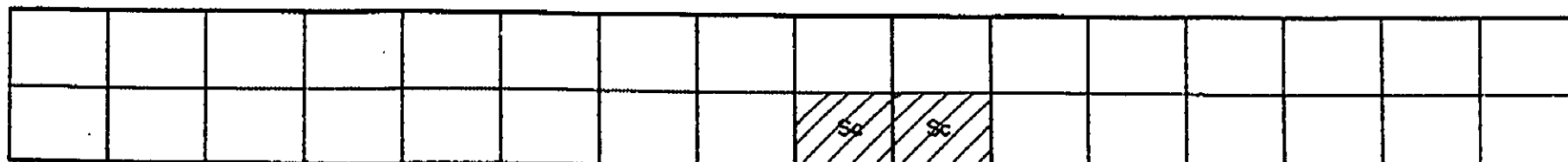
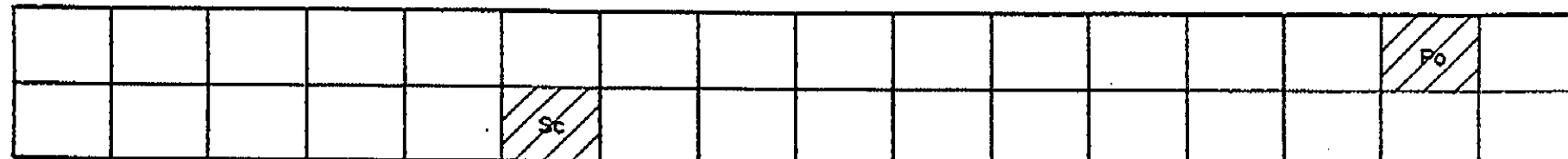
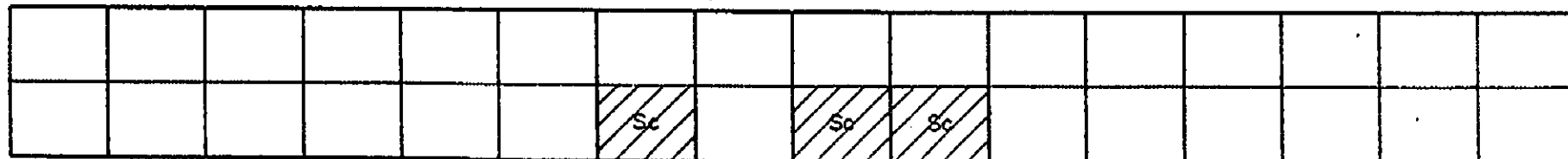
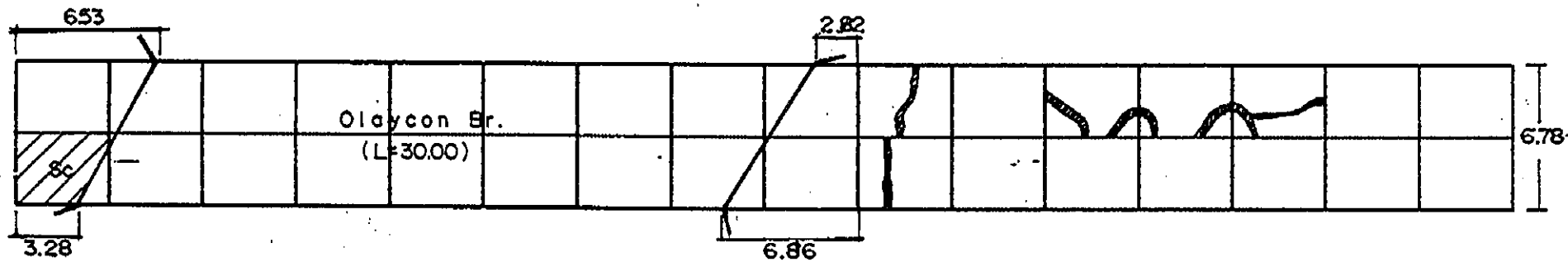
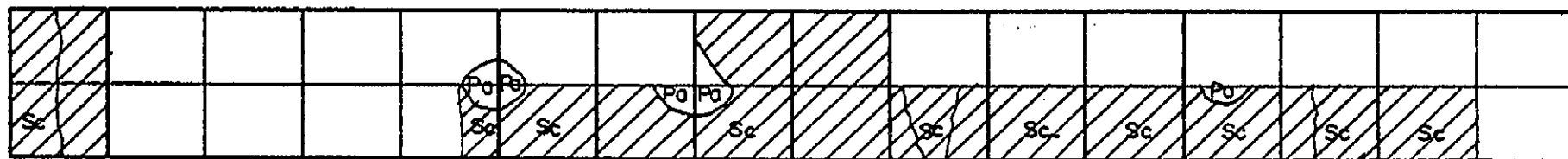
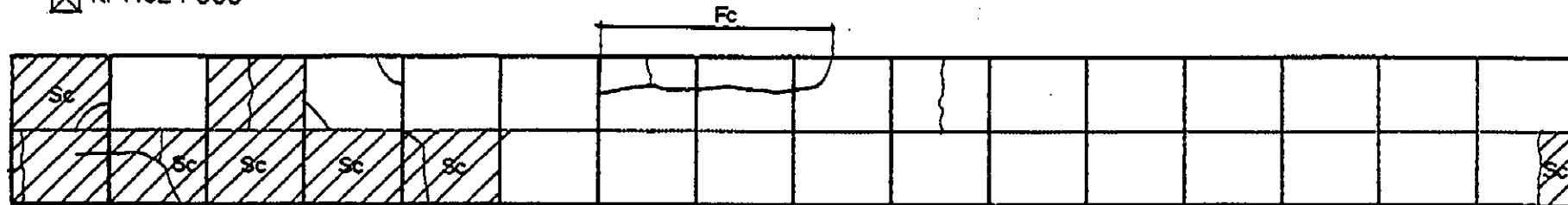
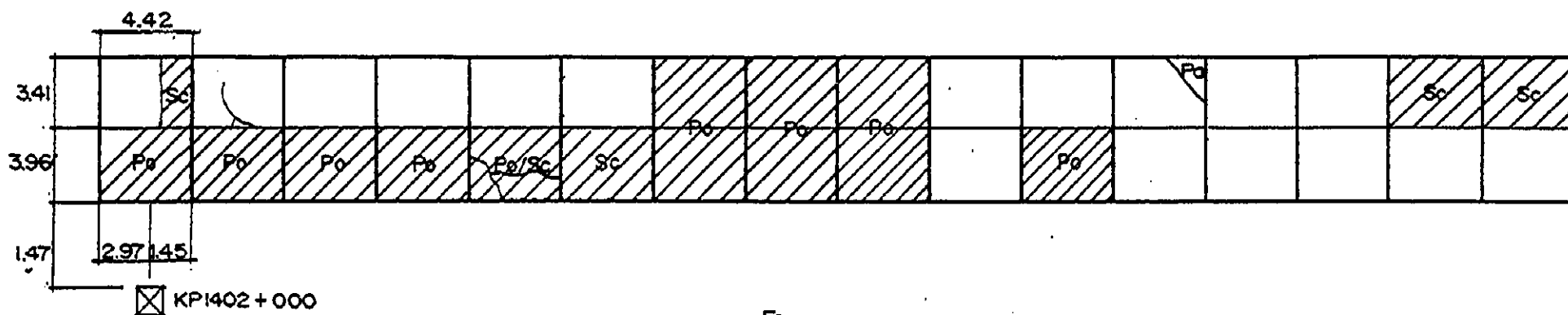

INVENTORY OF PAVEMENT SURFACE CONDITION

Km. 1402 + 000

Date: 10-29-95

Sheet No: 2/2

| | | | | | | | | | | | | | | | |
|--|--|----|--|--|----|--|--|--|----|----|----|--|----|--|--|
| | | | | | Po | | | | | | | | | | |
| | | Po | | | | | | | Po | Po | Po | | Po | | |

| | | | | | | | | | | | | | | | |
|----|----|--|--|----|----|--|--|----|----|----|----|----|----|----|----|
| | | | | | | | | | | | | | | | |
| Sc | De | | | Po | Po | | | Po | Po | Po | Po | Po | Po | Po | Po |

| | | | | | | | | | | | | | | | |
|----|----|----|----|--|--|--|--|----|----|----|----|----|----|--|--|
| | | | | | | | | | | | | | | | |
| Po | Po | Po | Po | | | | | Po | Po | Po | Po | Po | Po | | |

| | | | | | | | | | | | | | | | |
|--|---|--|--|---|---|---|--|--|--|----|--|--|--|----|--|
| | | | | | | | | | | | | | | | |
| | - | | | - | - | - | | | | Po | | | | De | |

| | | | | | | | | | | | | | | | |
|----|----|--|--|--|--|--|--|----|----|--|----|----|----|--|--|
| | | | | | | | | | | | | | | | |
| Po | Po | | | | | | | Sc | Sc | | De | Sc | Po | | |

| | | | | | | | | | | | | | | | |
|----|--|----|----|----|----|----|----|----|----|----|--|----|----|----|----|
| Sc | | | | | Sc | Sc | Sc | | | Po | | Sc | | | |
| | | Po | Po | Po | Po | Po | Po | Po | Po | Po | | Po | Po | Po | Po |

| | | | | | | | | | | | | | | | |
|----|----|----|--|--|----|----|----|----|----|----|--|----|--|----|----|
| | | | | | | | | | | | | | | | |
| Po | Po | Sc | | | Po | Po | Sc | Po | Po | Po | | Sc | | Po | Po |

4.39

4.09 0.30 1.25

6.76

☒ KPI403+000

INVENTORY OF PAVEMENT SURFACE CONDITION

Km. 1403+000

Date: 10-29-95

Sheet No: 1/2

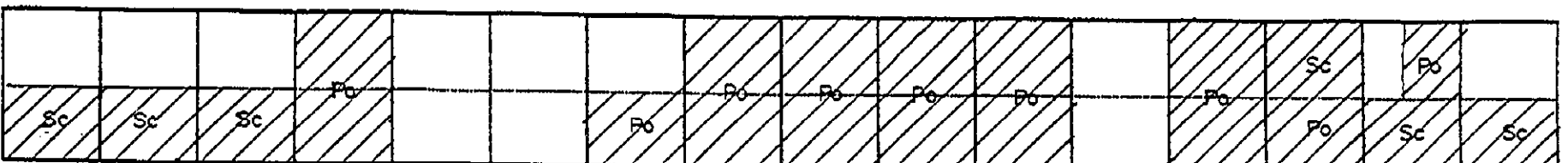
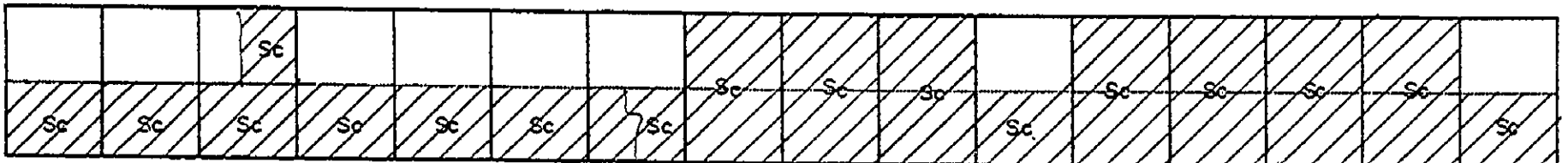
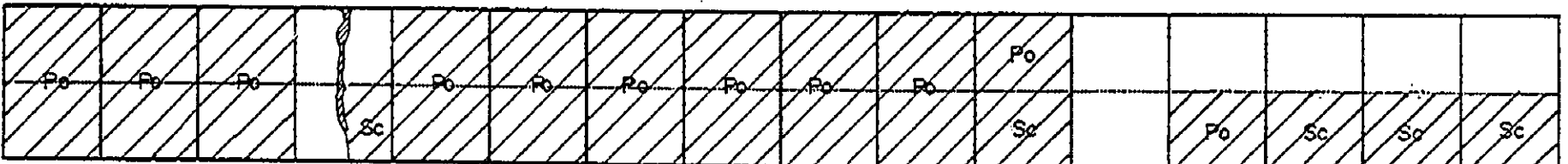
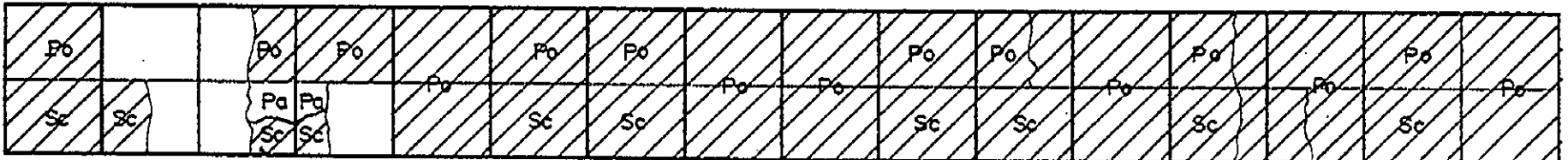
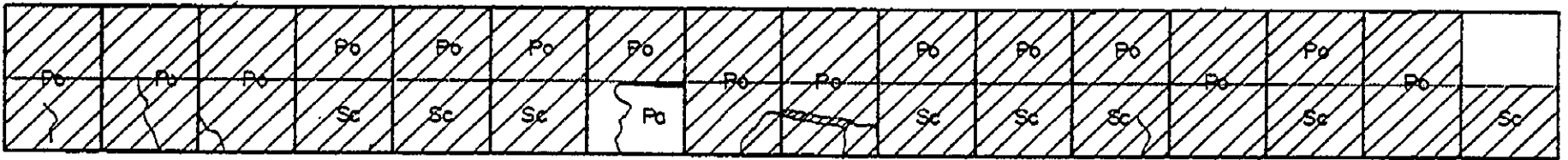
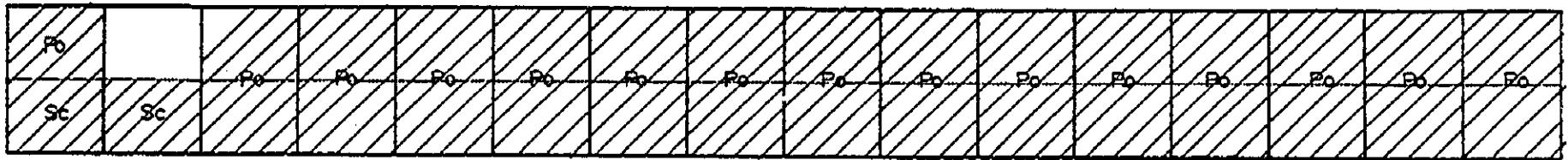
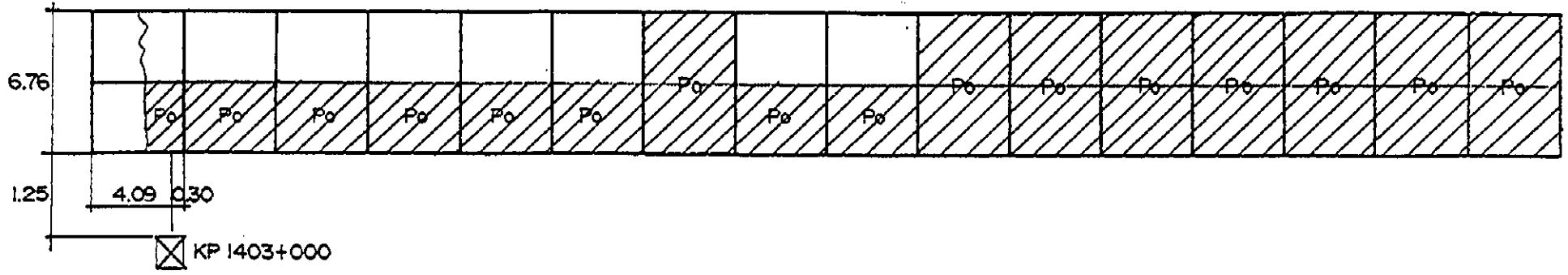

INVENTORY OF PAVEMENT SURFACE CONDITION

Date: 10-29-95

Km. 1403 + 000

Sheet No: 2/2

| | | | | | | | | | | | | | | |
|----|----|----|----|----|----|----|----|----|----|----|----|----|----|----|
| Po | | Po | Po | Po | | | | | Po | Po | Po | | | |
| Sc | Po | Sc | Sc | Sc | Sc | Sc | Sc | Sc | Sc | Po | Po | Po | Po | Po |

| | | | | | | | | | | | | | | |
|----|----|----|----|----|----|----|----|----|----|----|----|----|----|----|
| | | | Sc | | | | | | Sc | Sc | | | | |
| Po | Po | Po | Po | Po | Po | Sc | Po | Po | Po | Po | Sc | Po | Sc | Po |

| | | | | | | | | | | | | | | |
|----|----|----|----|----|----|----|----|----|----|----|----|----|----|----|
| | | | | | | | | | | | | | | |
| Po | Sc | Sc | Sc | Po | Po | Sc | Sc | Sc | Sc | Sc | Po | Po | Po | Po |

| | | | | | | | | | | | | | | |
|----|----|----|----|----|----|----|----|----|----|----|----|----|----|----|
| Sc | Sc | Sc | Sc | Sc | Sc | Sc | Sc | Sc | Sc | | | | | |
| Po | - | Sc | Sc | Sc | Sc | Sc | Sc | Sc | Sc | Sc | Sc | Sc | Sc | Po |

| | | | | | | | | | | | | | | |
|----|----|----|----|----|----|----|----|----|----|----|----|----|----|----|
| | | | | | Sc | Sc | Sc | Sc | Sc | | | Sc | Sc | |
| Po | Sc | Sc | Po | Po | Po | Sc | Sc | Sc | Po | Sc | Sc | Po | Sc | Sc |

| | | | | | | | | | | | | | | |
|----|----|----|----|----|----|----|----|----|----|----|----|----|----|----|
| Po | | | Po | | | | | | | | | | | |
| Sc | Sc | Sc | Sc | Sc | Sc | Sc | Sc | Sc | Sc | Sc | Sc | Sc | Sc | Sc |

| | | | | | | | | | | | | | | |
|----|----|----|----|----|----|----|----|----|----|----|----|----|----|----|
| | | | | | | | | | | | | | | |
| Sc | Sc | Po | Po | Po | Po | Po | Po | Po | Po | Po | Po | Sc | Sc | Sc |

