

D I BOMBAR I

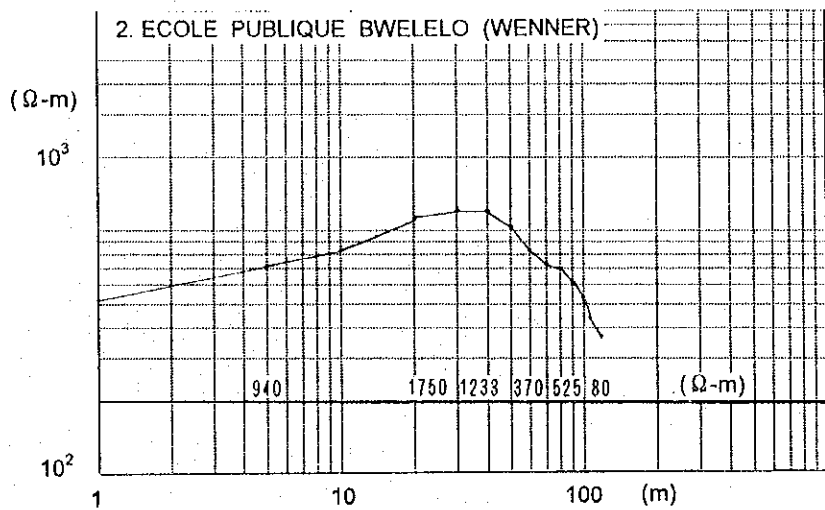

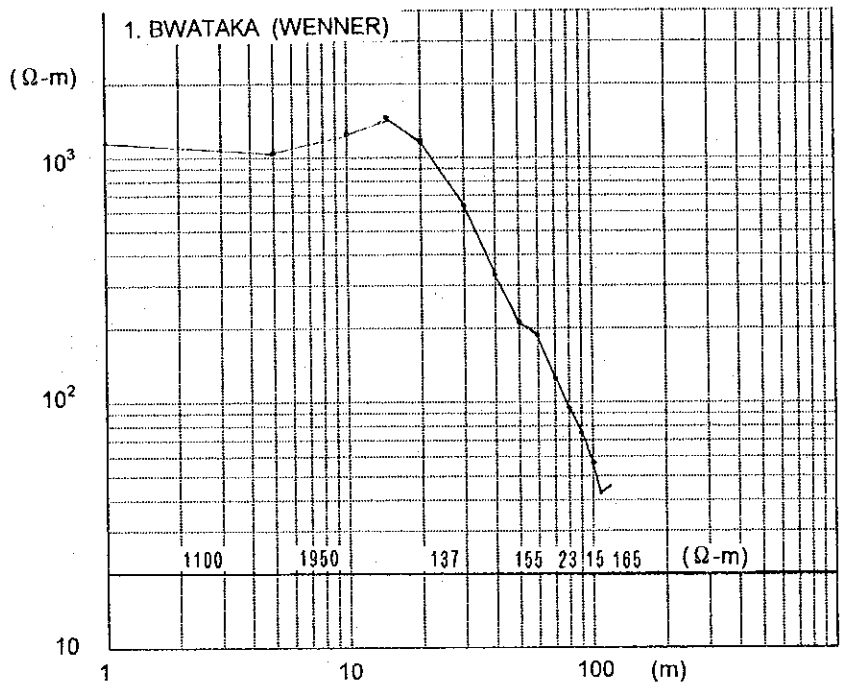

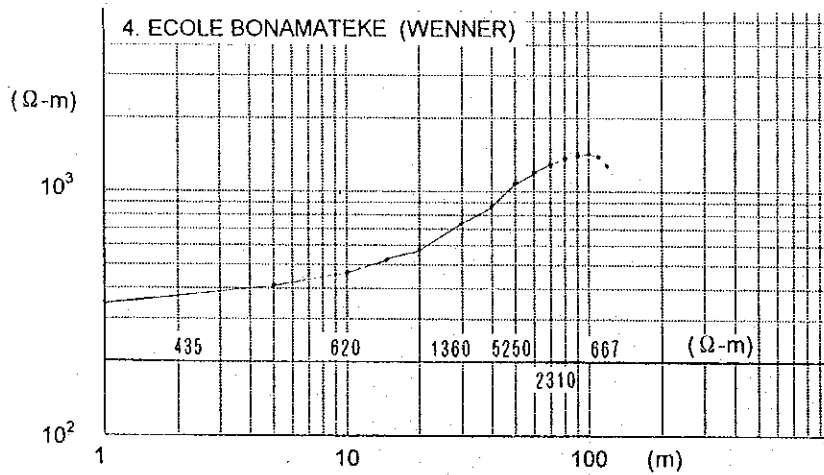

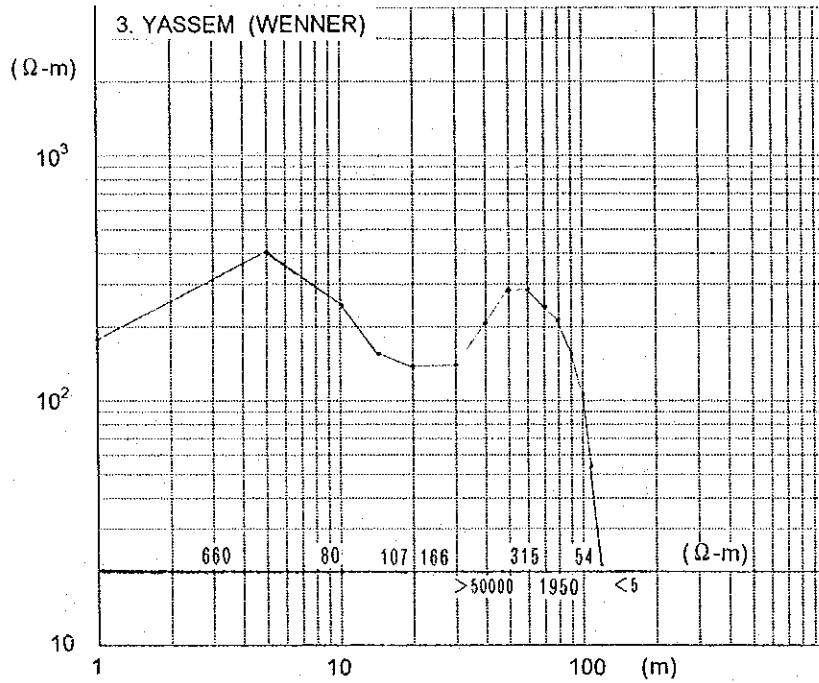
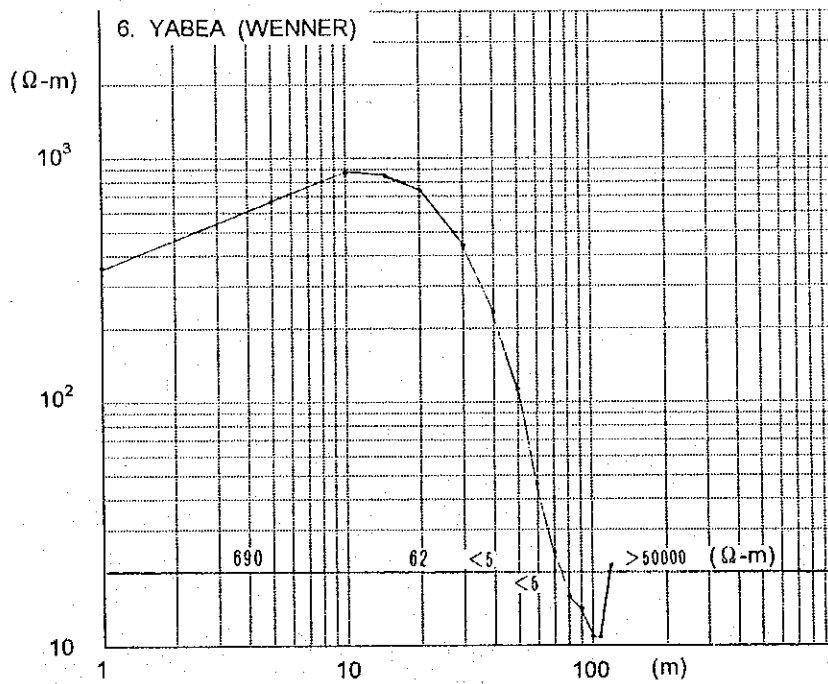
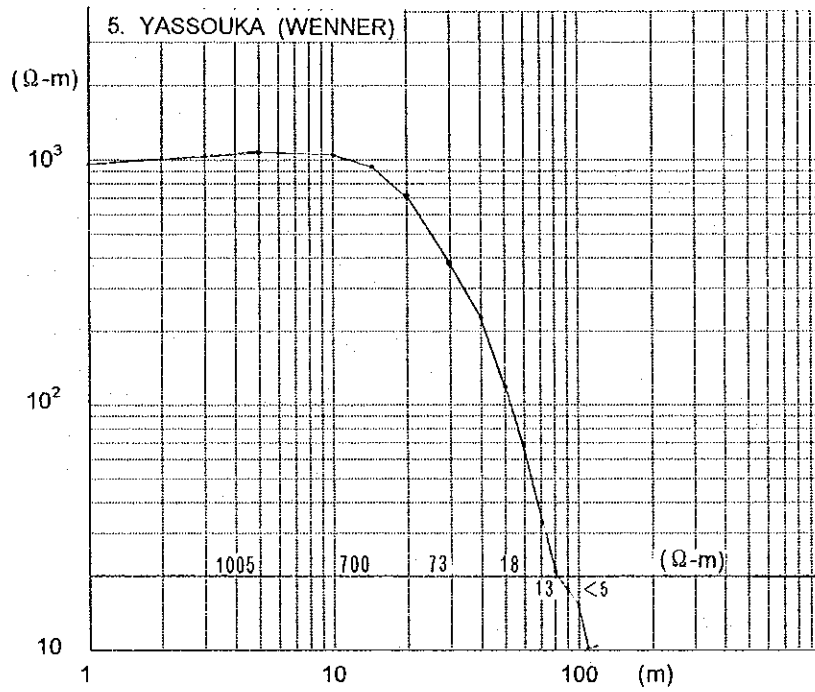
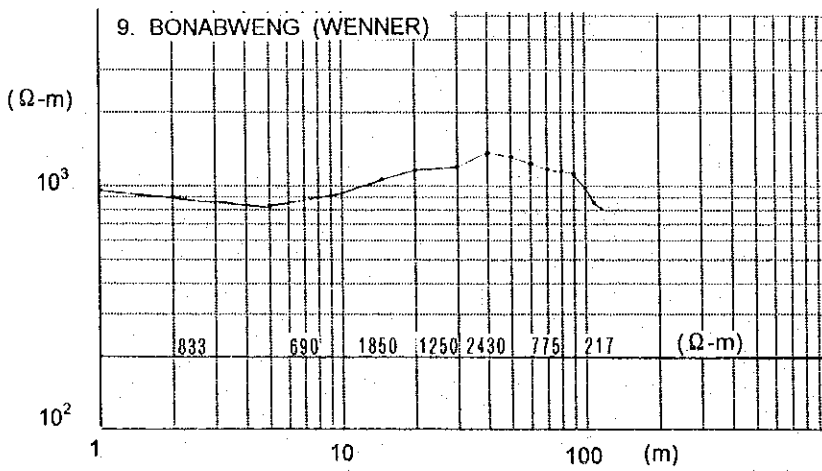
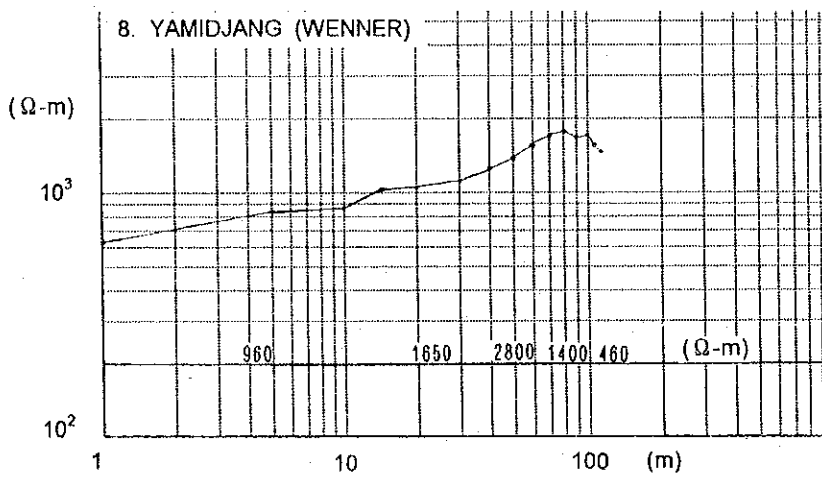
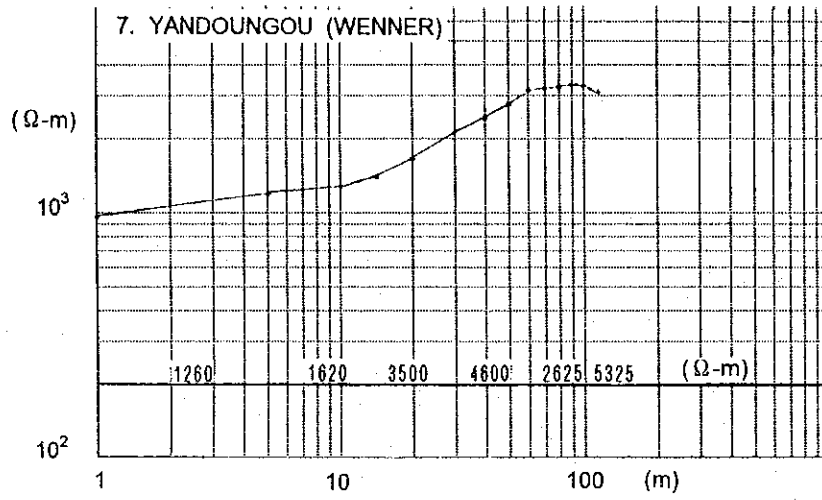

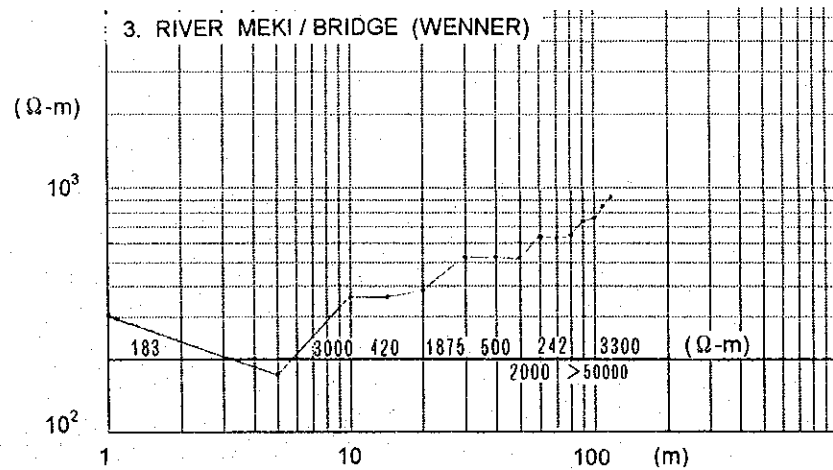
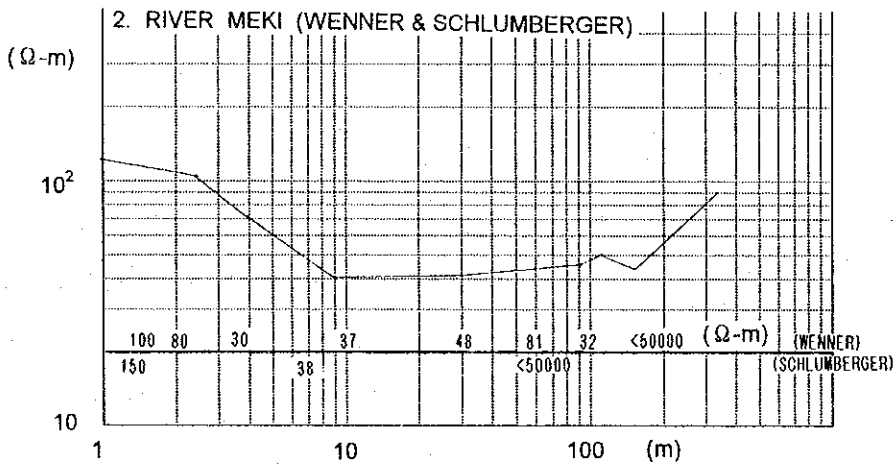
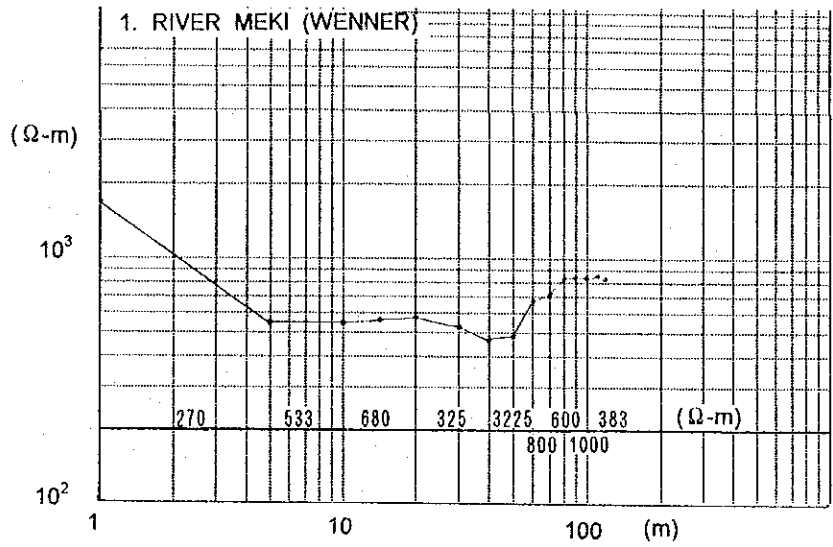

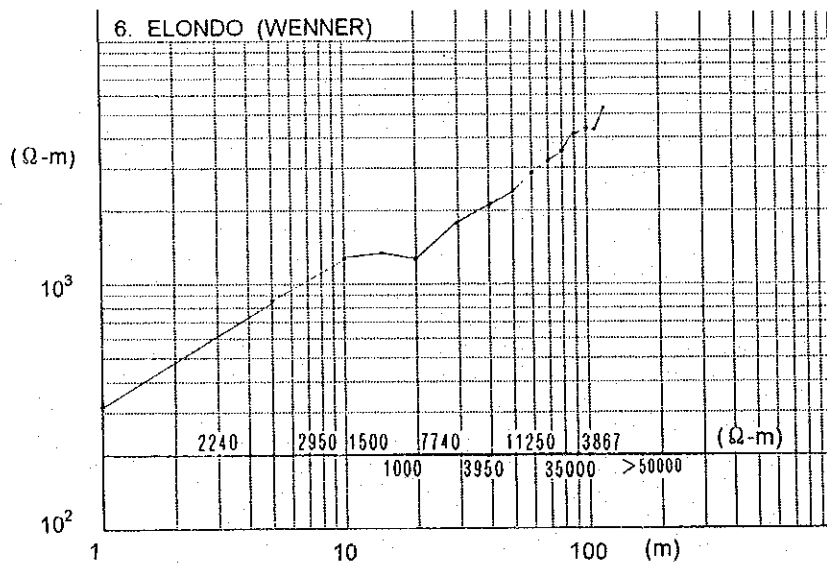
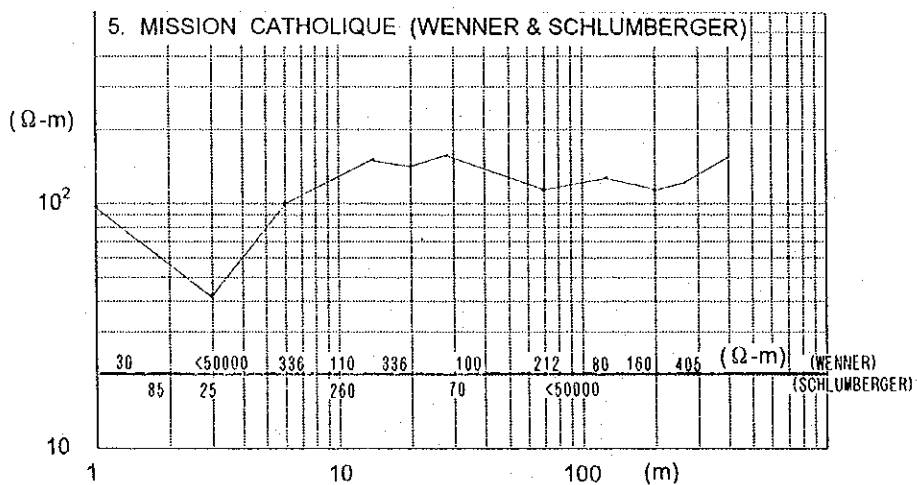
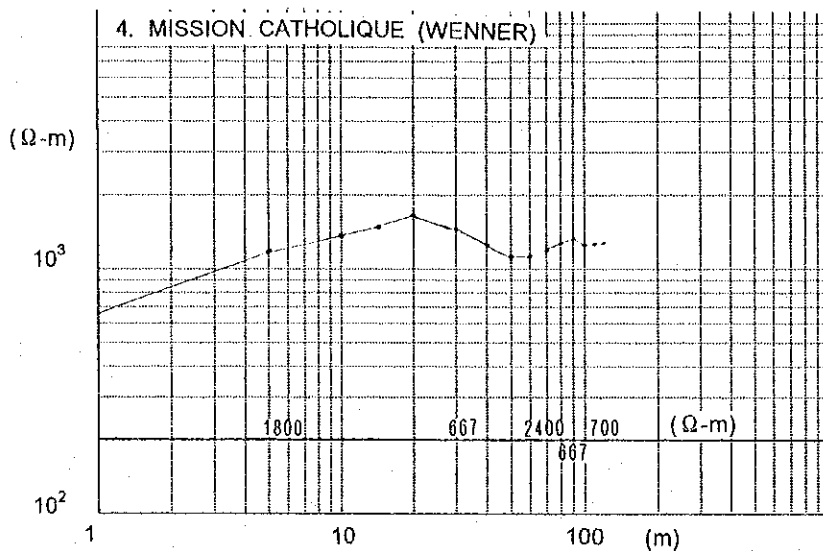

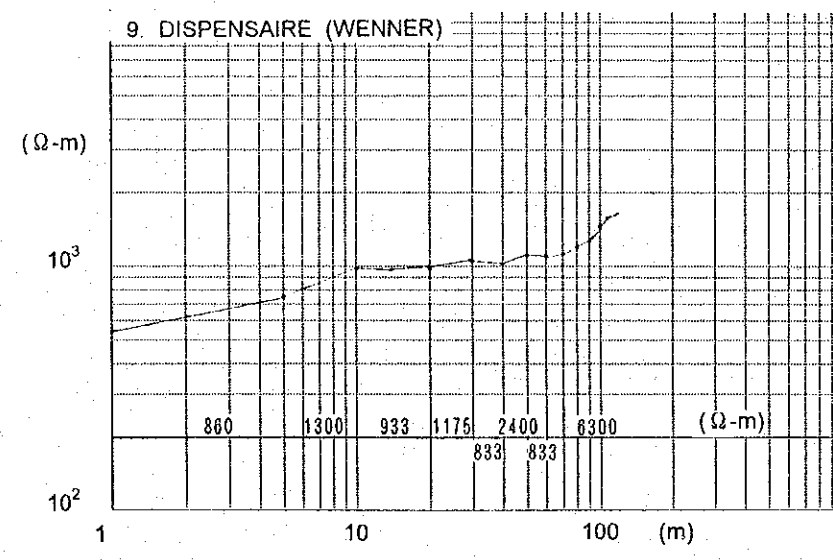
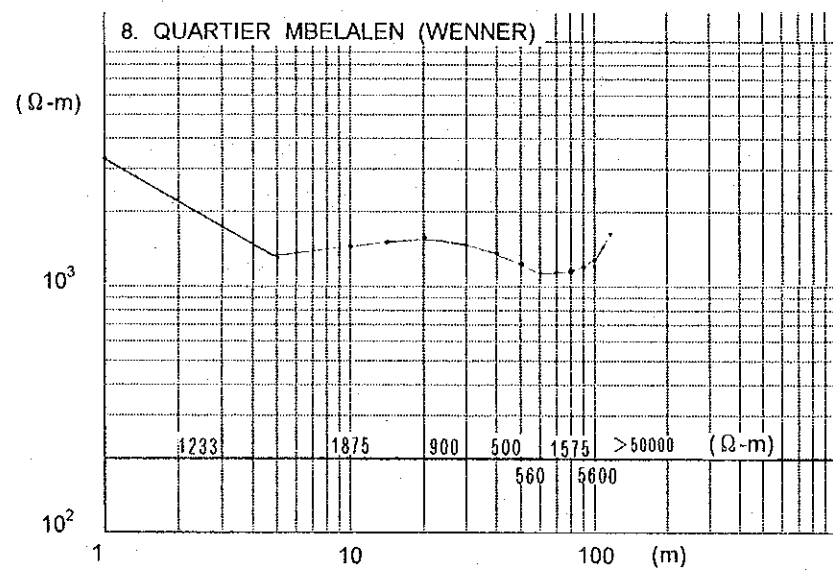
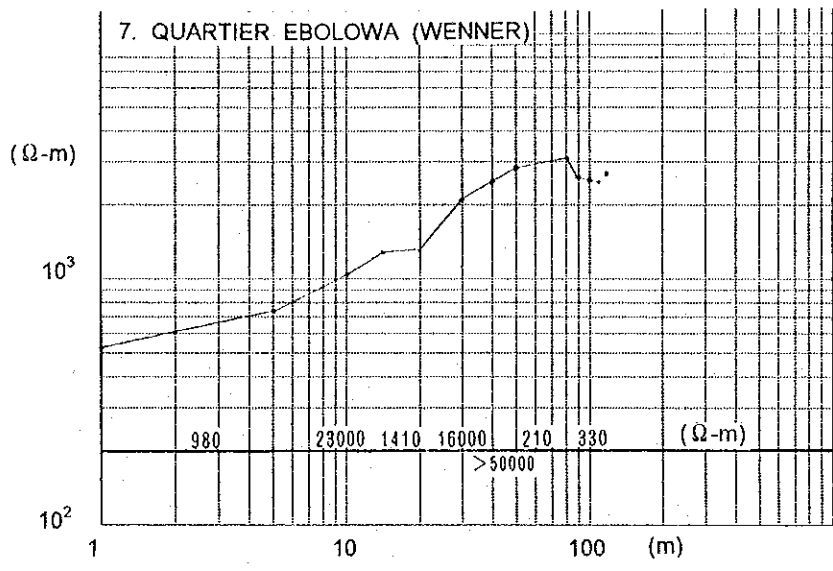

**NGOMEDZAP**

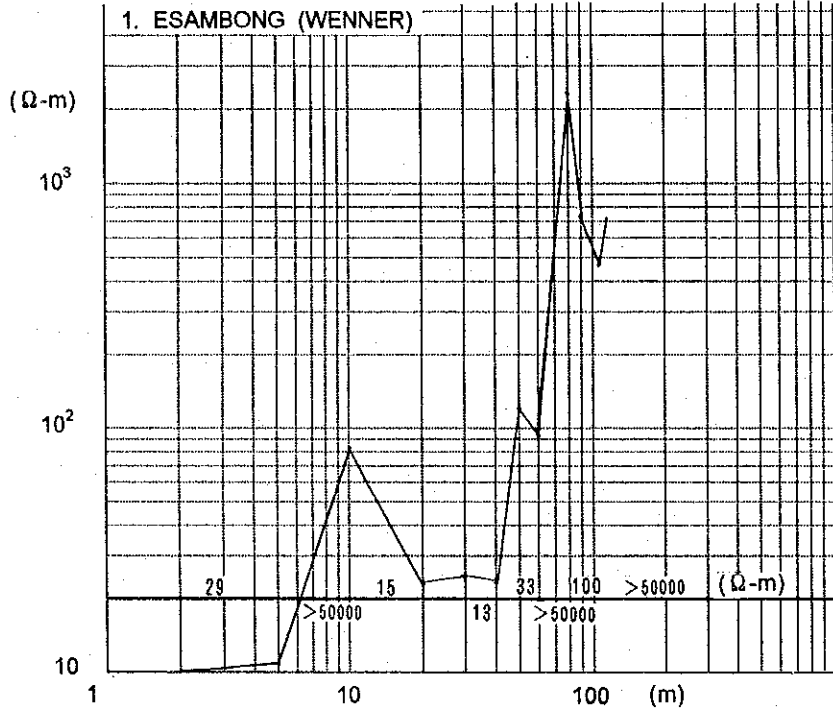

**YANGBEN**

3. EBAYA (HORIZONTAL)

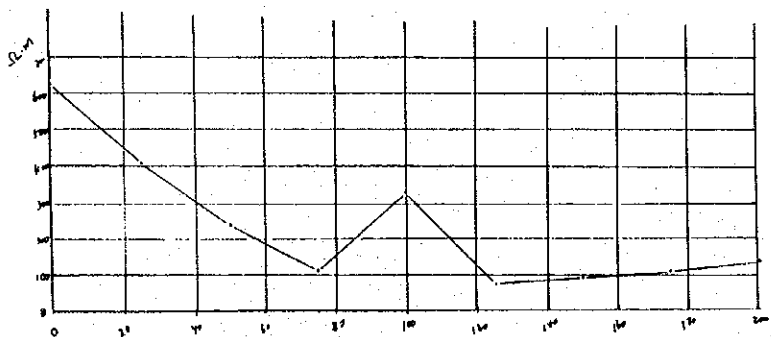



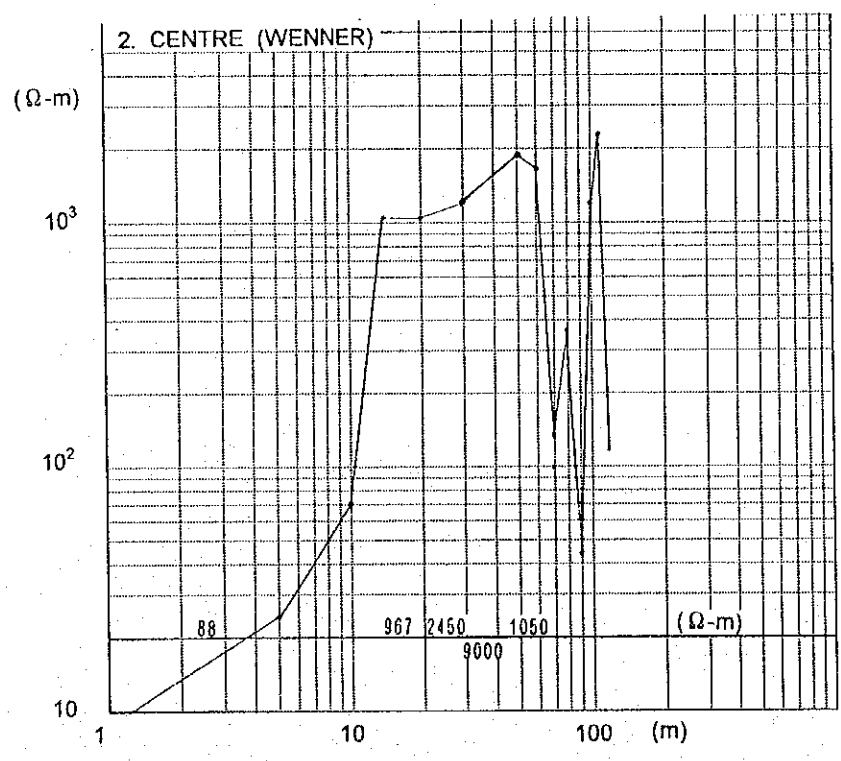
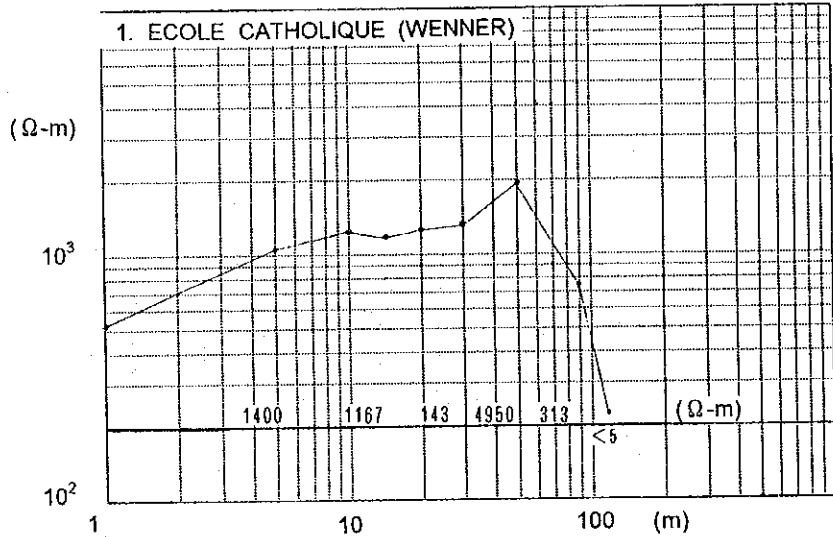

# YANGBEN

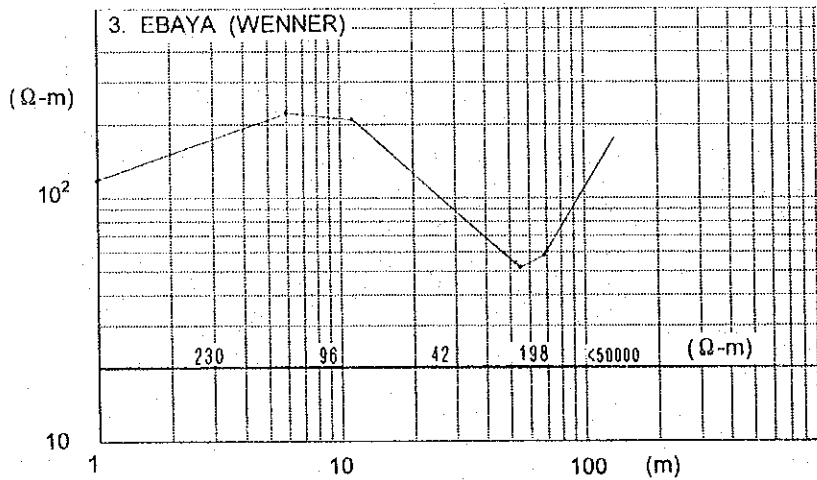
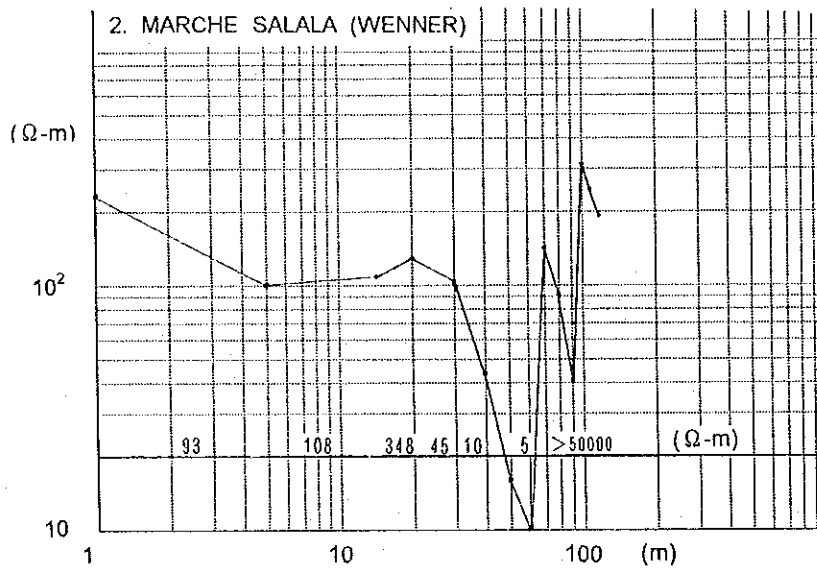
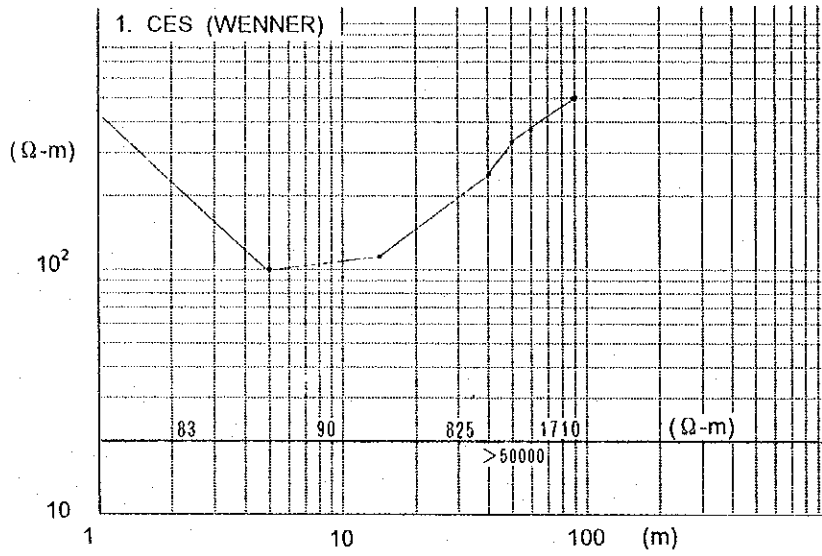

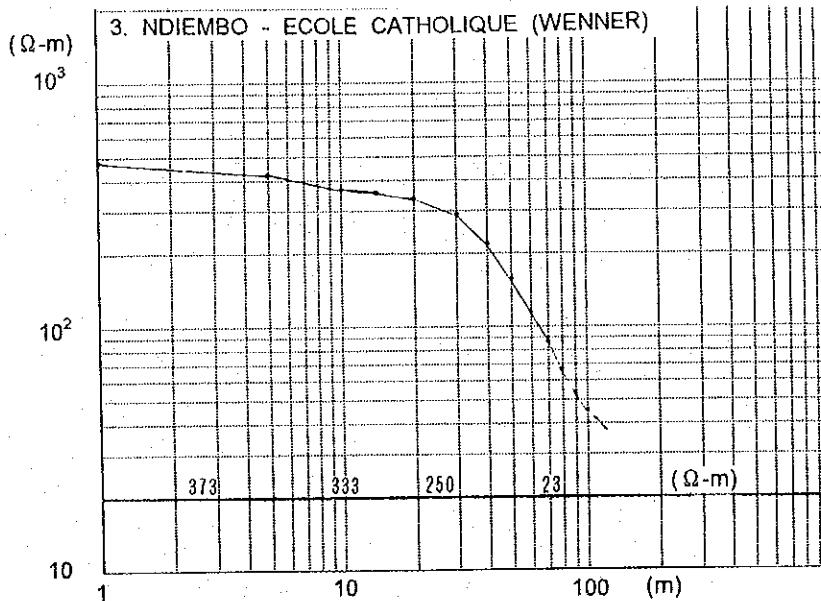
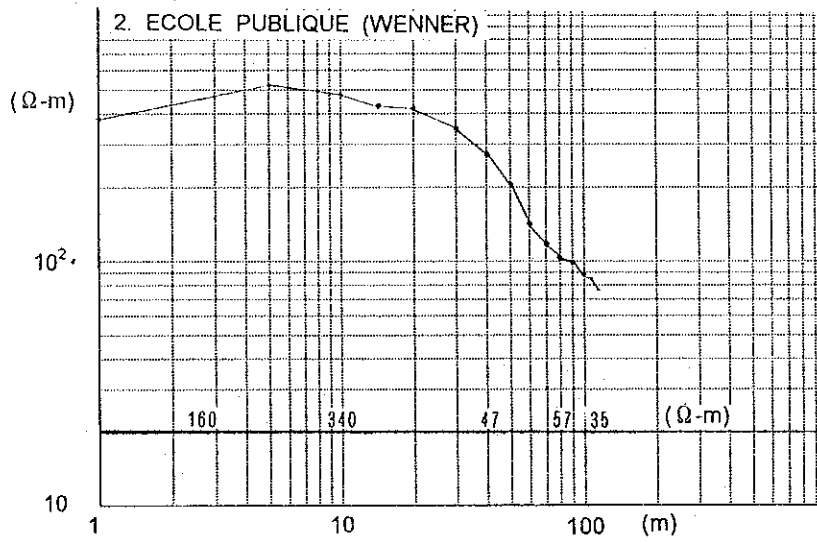
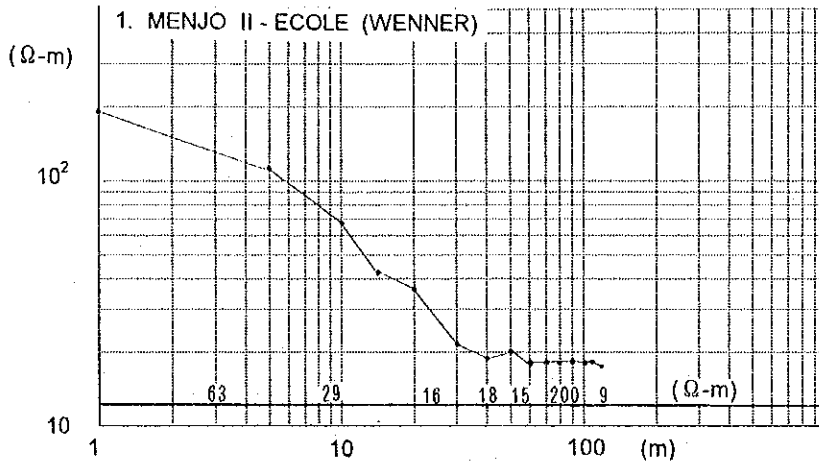

**BANGOU**

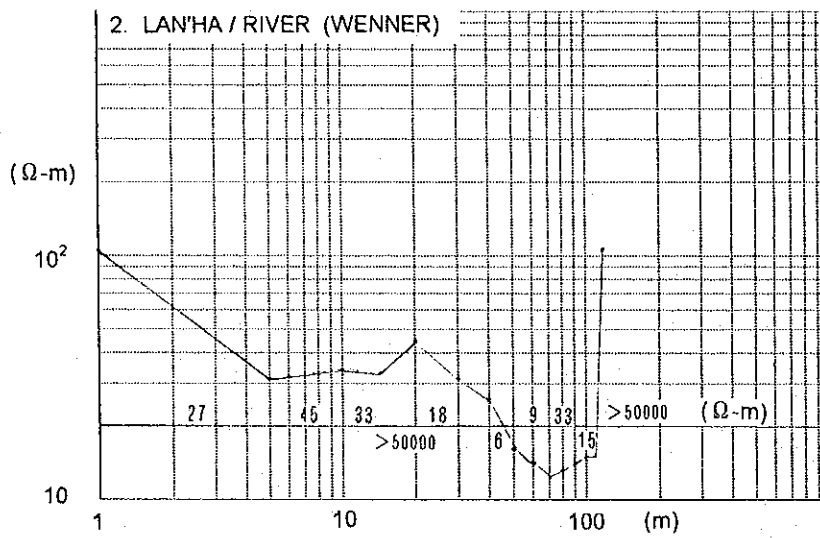
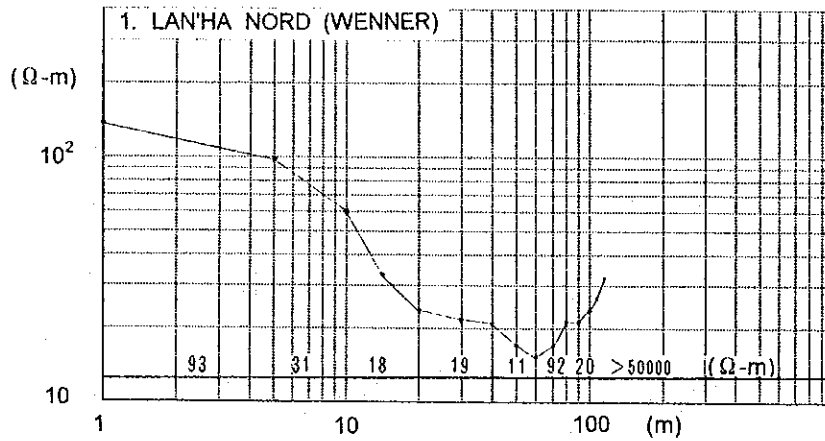

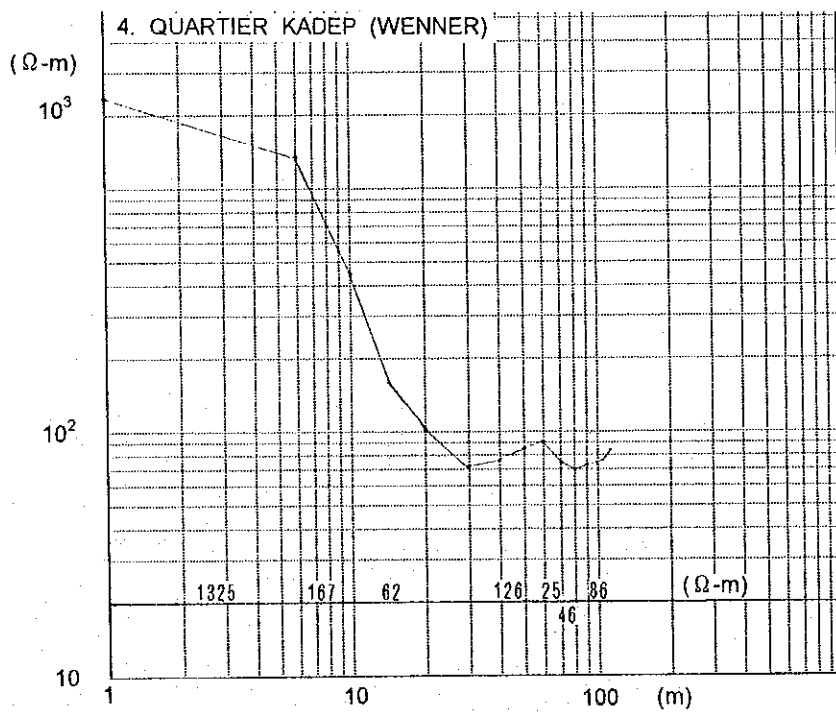
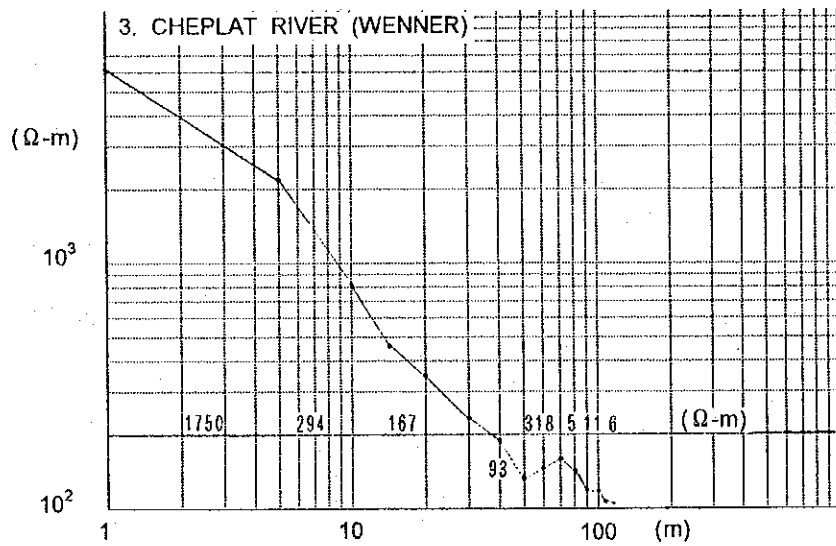

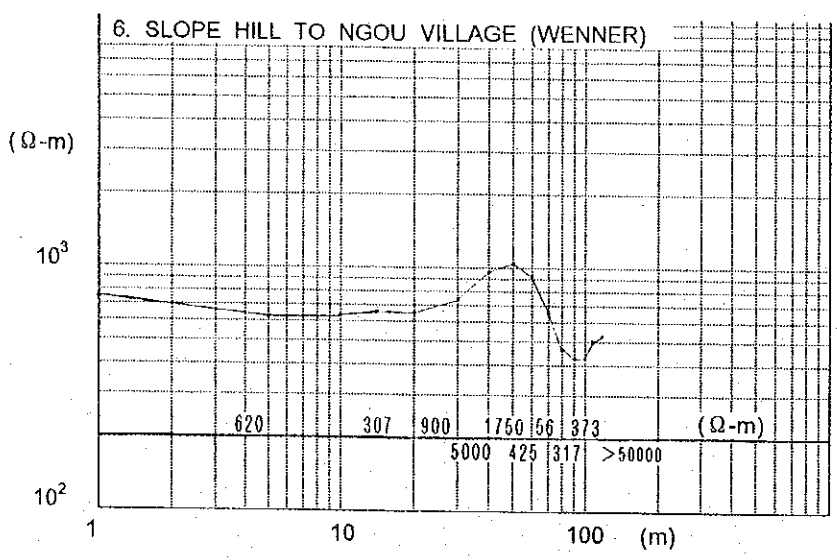
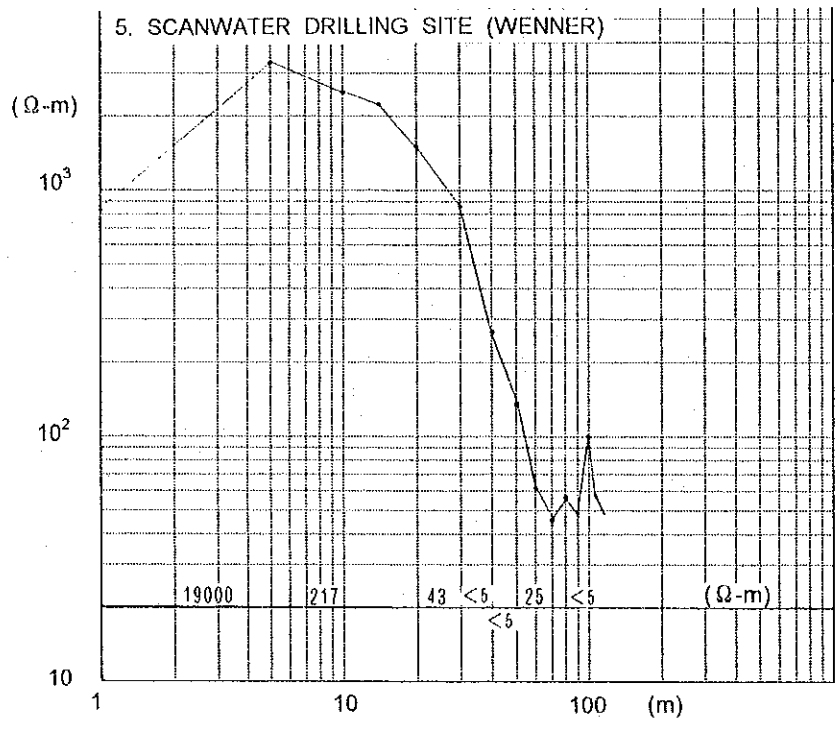

**TONGA**

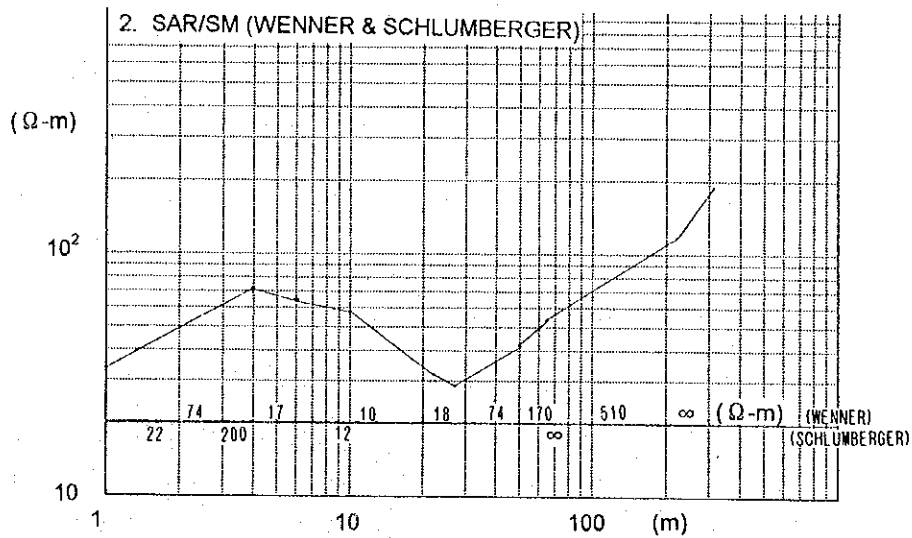
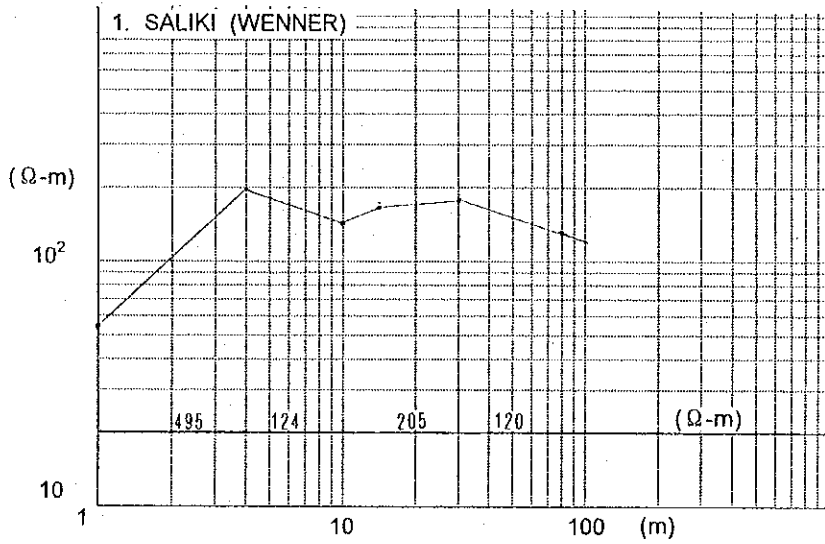

**AKOM II**

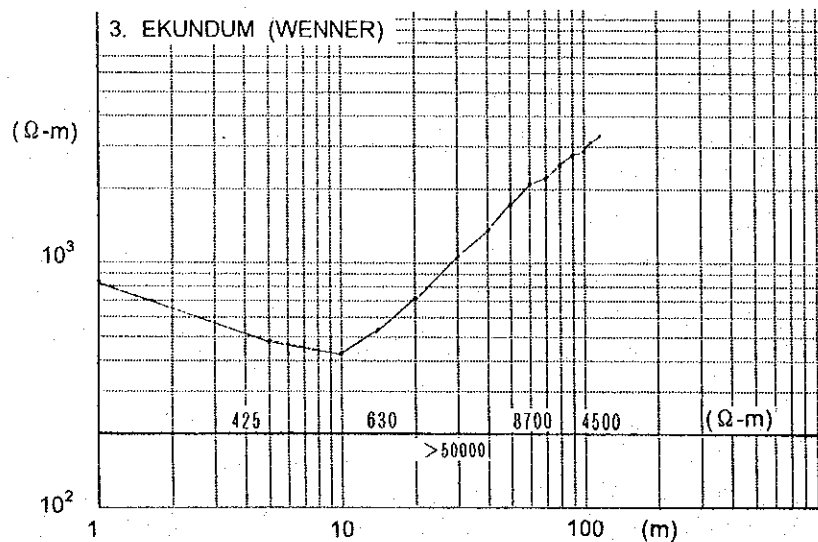
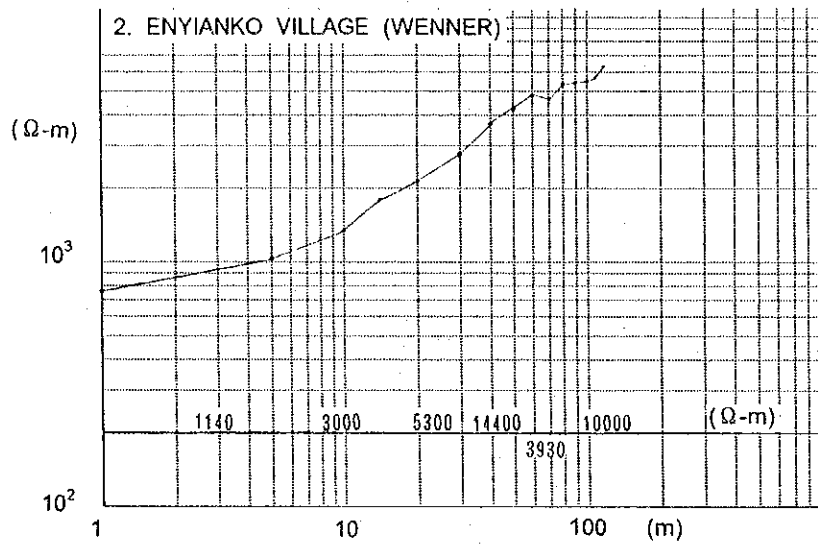
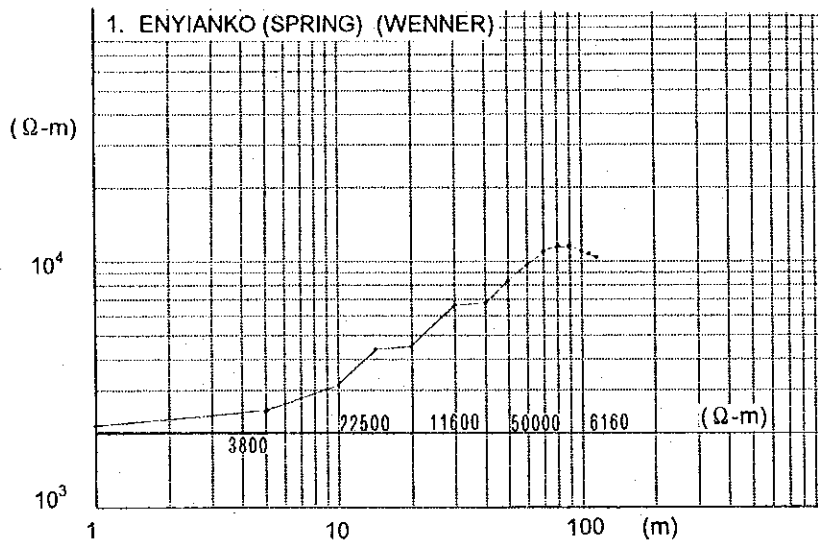



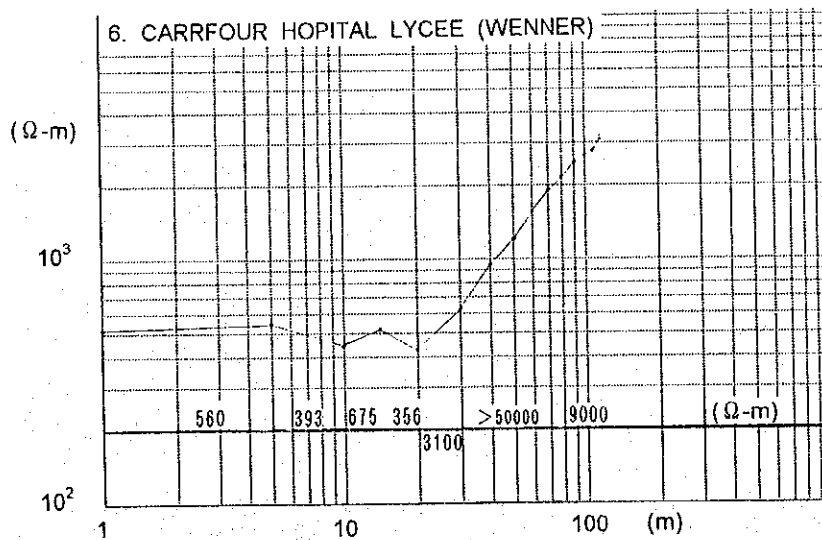
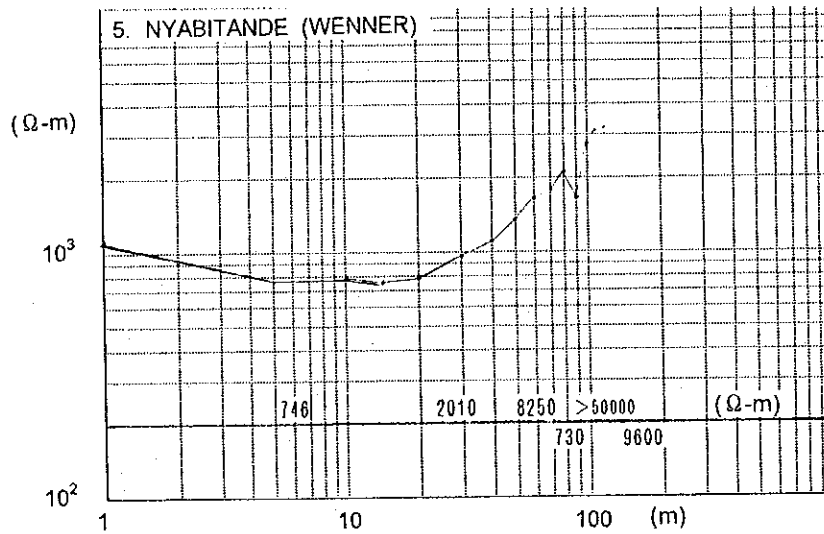
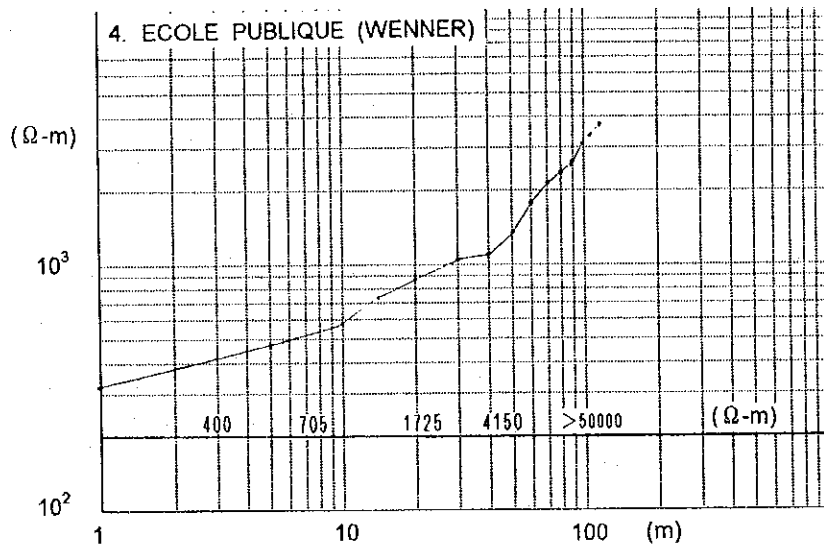

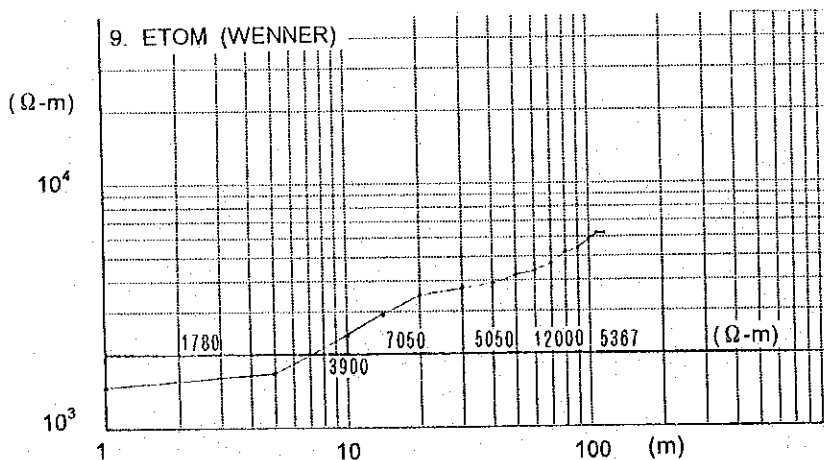
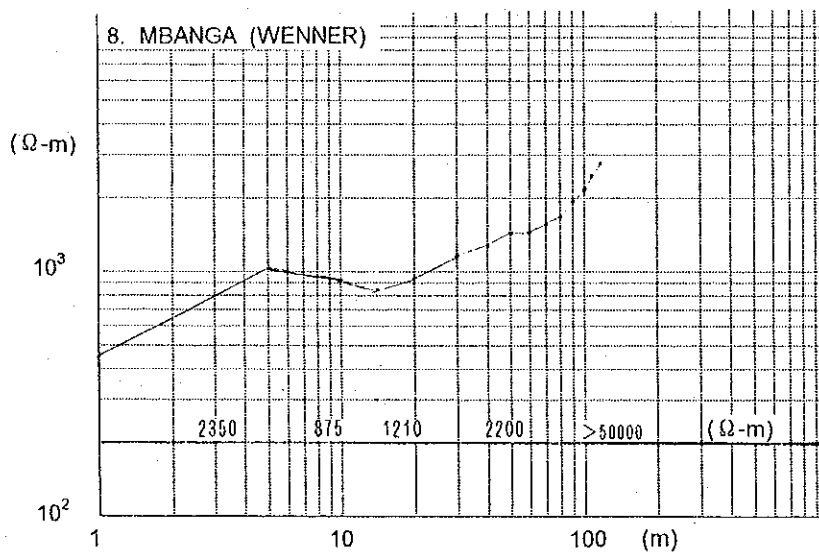
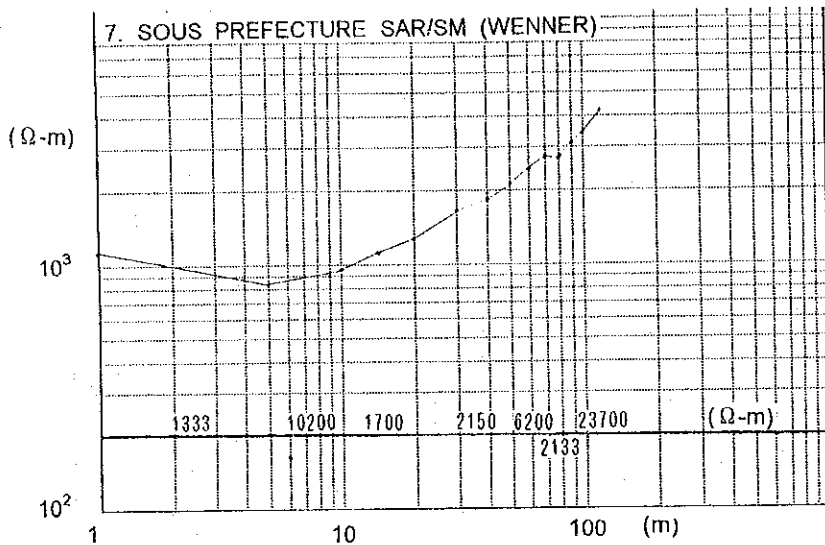

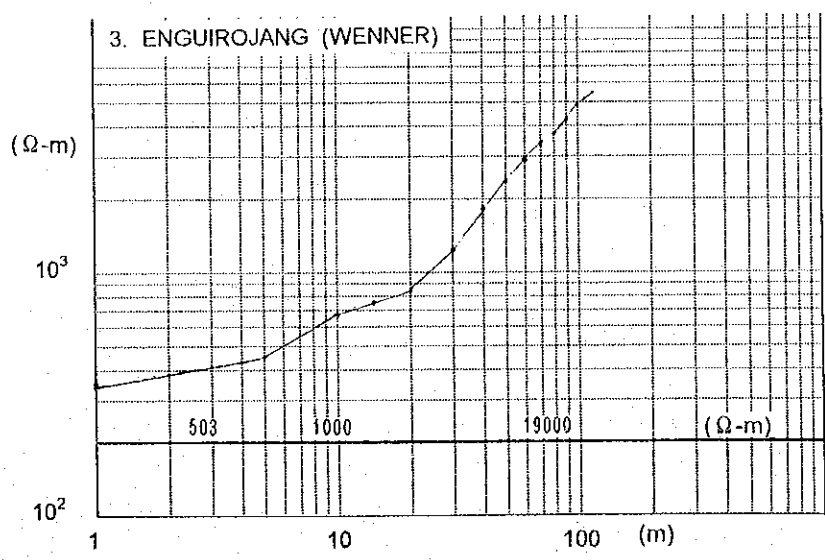
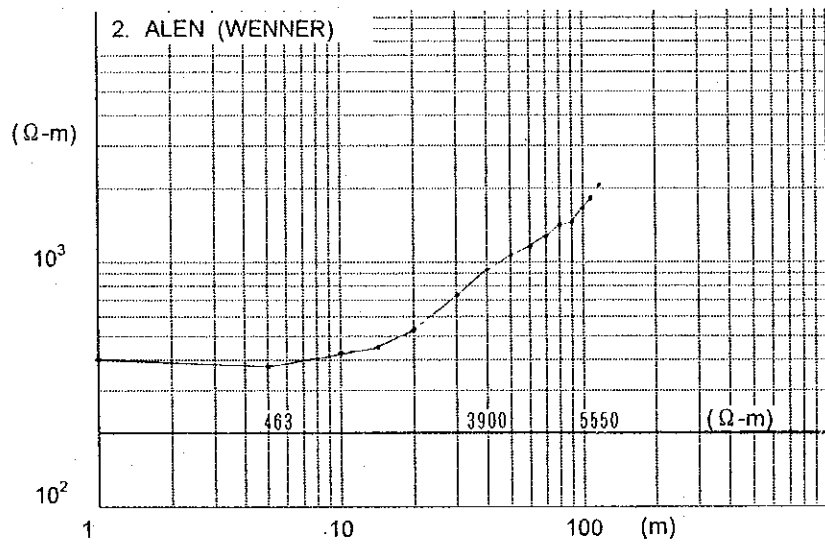
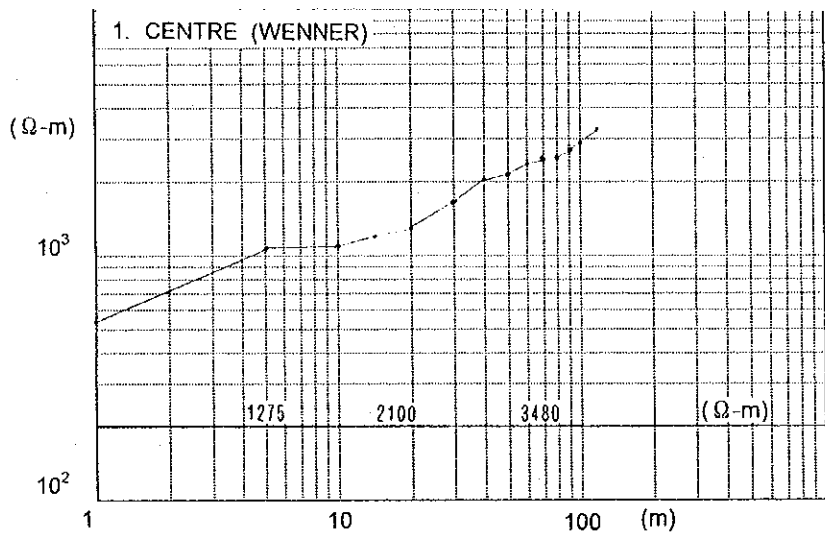



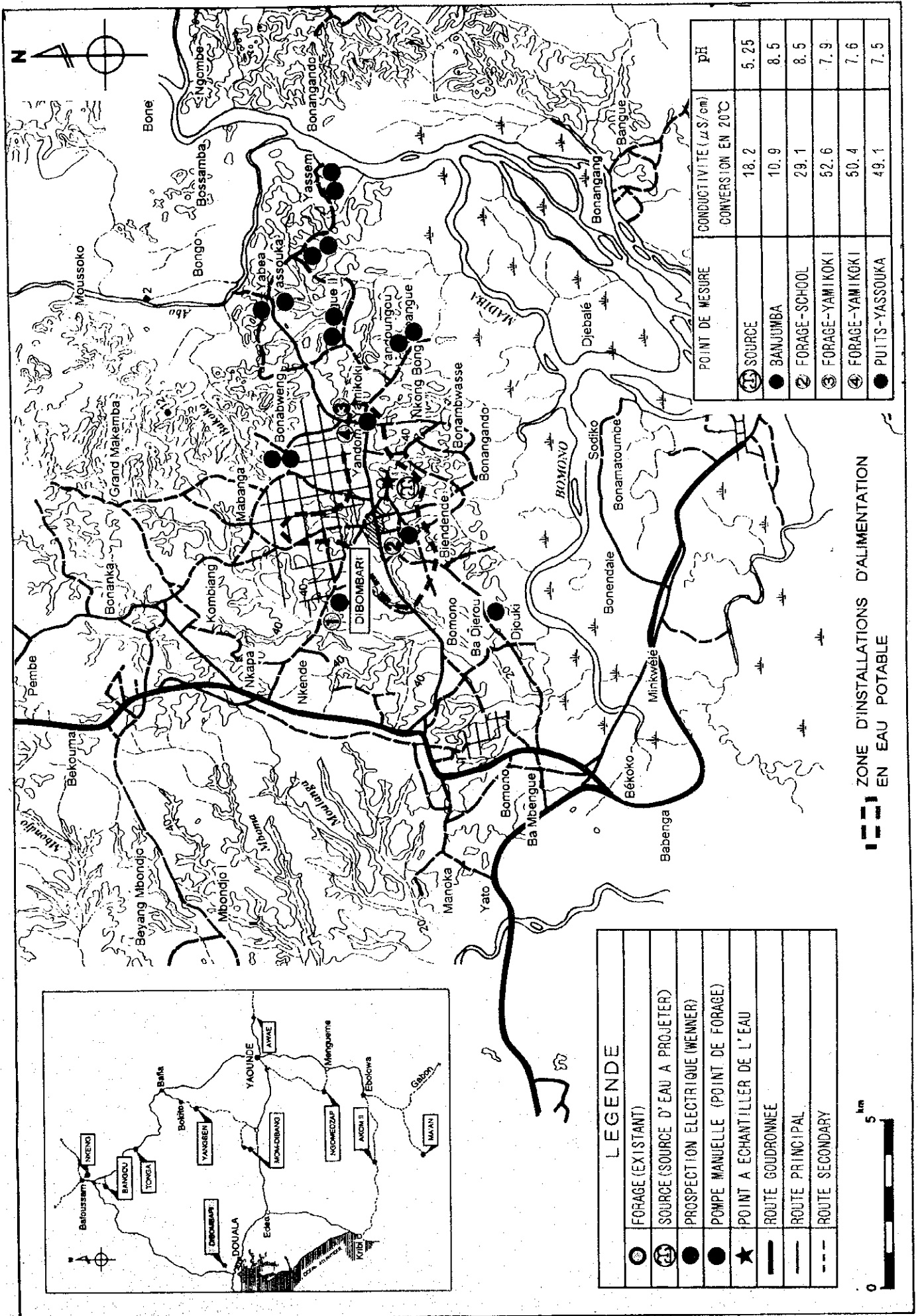

**LEGENDE**

○	FORAGE (EXISTANT)
⊕	SOURCE (SOURCE D'EAU A PROJETER)
●	PROSPECTION ELECTRIQUE (WENNER)
★	POMPE MANUELLE (POINT DE FORAGE)
—	ROUTE A ECHANTILLER DE L'EAU
—	ROUTE GOUDRONNEE
---	ROUTE PRINCIPAL
---	ROUTE SECONDARY

POINT DE MESURE	CONDUCTIVITE (μS/cm) CONVERSION EN 20°C	PH
⊕ SOURCE	18.2	5.25
● BANJUMBA	10.9	8.5
⊕ FORAGE-SCHOOL	29.1	8.5
⊕ FORAGE-YAMIKOKI	52.6	7.9
⊕ FORAGE-YAMIKOKI	50.4	7.6
● PUITTS-YASSOUKA	49.1	7.5

**--- ZONE D'INSTALLATIONS D'ALIMENTATION EN EAU POTABLE**





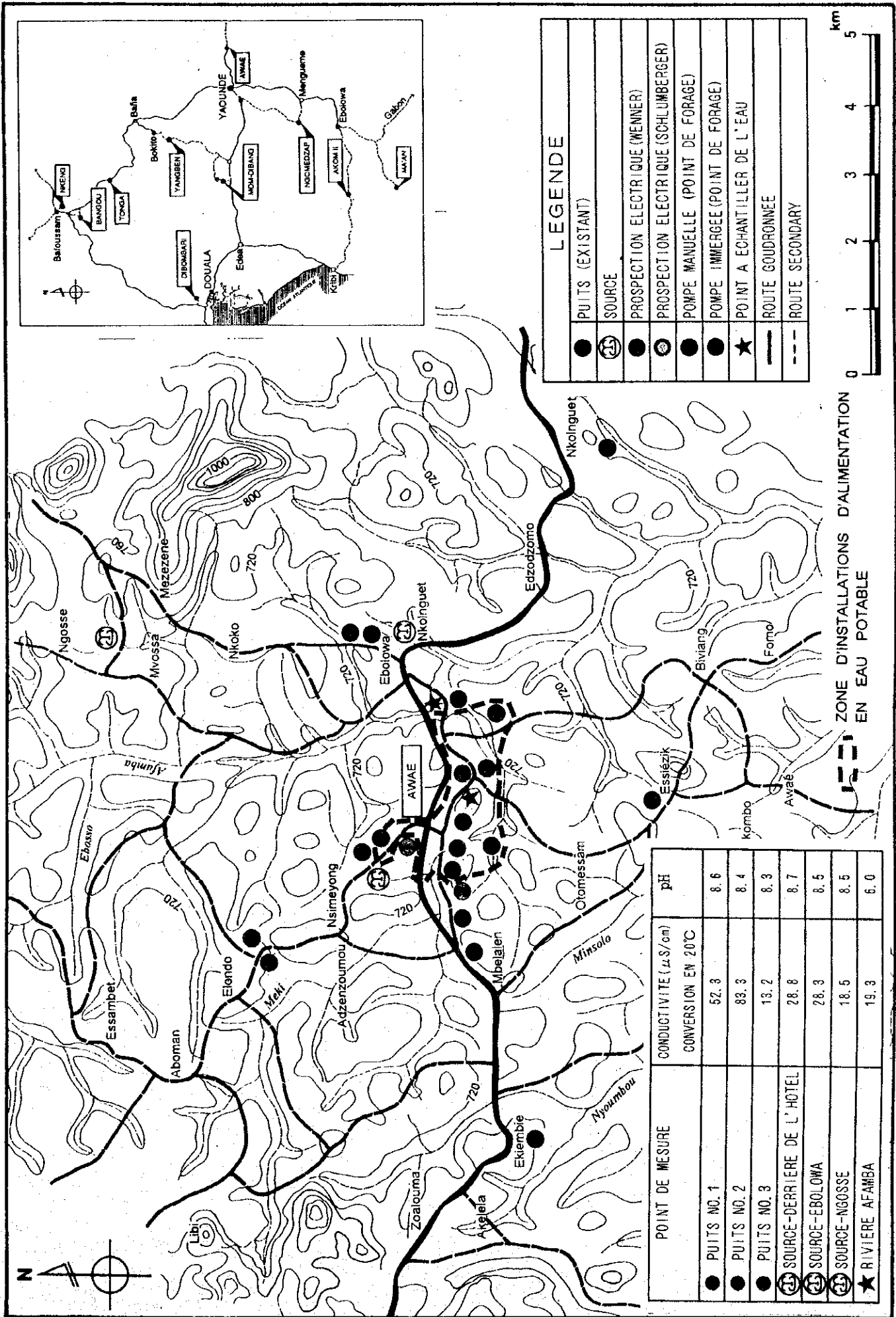

**LEGENDE**

●	PUITS (EXISTANT)
⊕	SOURCE
●	PROSPECTION ELECTRIQUE (WENNER)
⊕	PROSPECTION ELECTRIQUE (SCHLUMBERGER)
●	POMPE MANUELLE (POINT DE FORAGE)
●	POMPE IMMERGEE (POINT DE FORAGE)
★	POINT A ECHANTILLONNAGE DE L'EAU
—	ROUTE GOUDRONNEE
- - -	ROUTE SECONDARY

POINT DE MESURE	CONDUCTIVITE (μS/cm)	pH
● PUIITS NO. 1	52.3	8.6
● PUIITS NO. 2	83.3	8.4
● PUIITS NO. 3	13.2	8.3
⊕ SOURCE-DERRIERE DE L' HOTEL	28.8	8.7
⊕ SOURCE-EBOLOWA	28.3	8.5
⊕ SOURCE-NGOSSE	18.5	8.5
★ RIVIERE AFAMBA	19.3	6.0

ZONE D'INSTALLATIONS D'ALIMENTATION EN EAU POTABLE

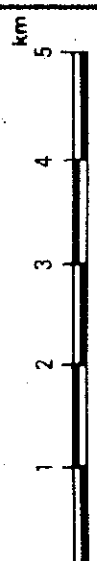









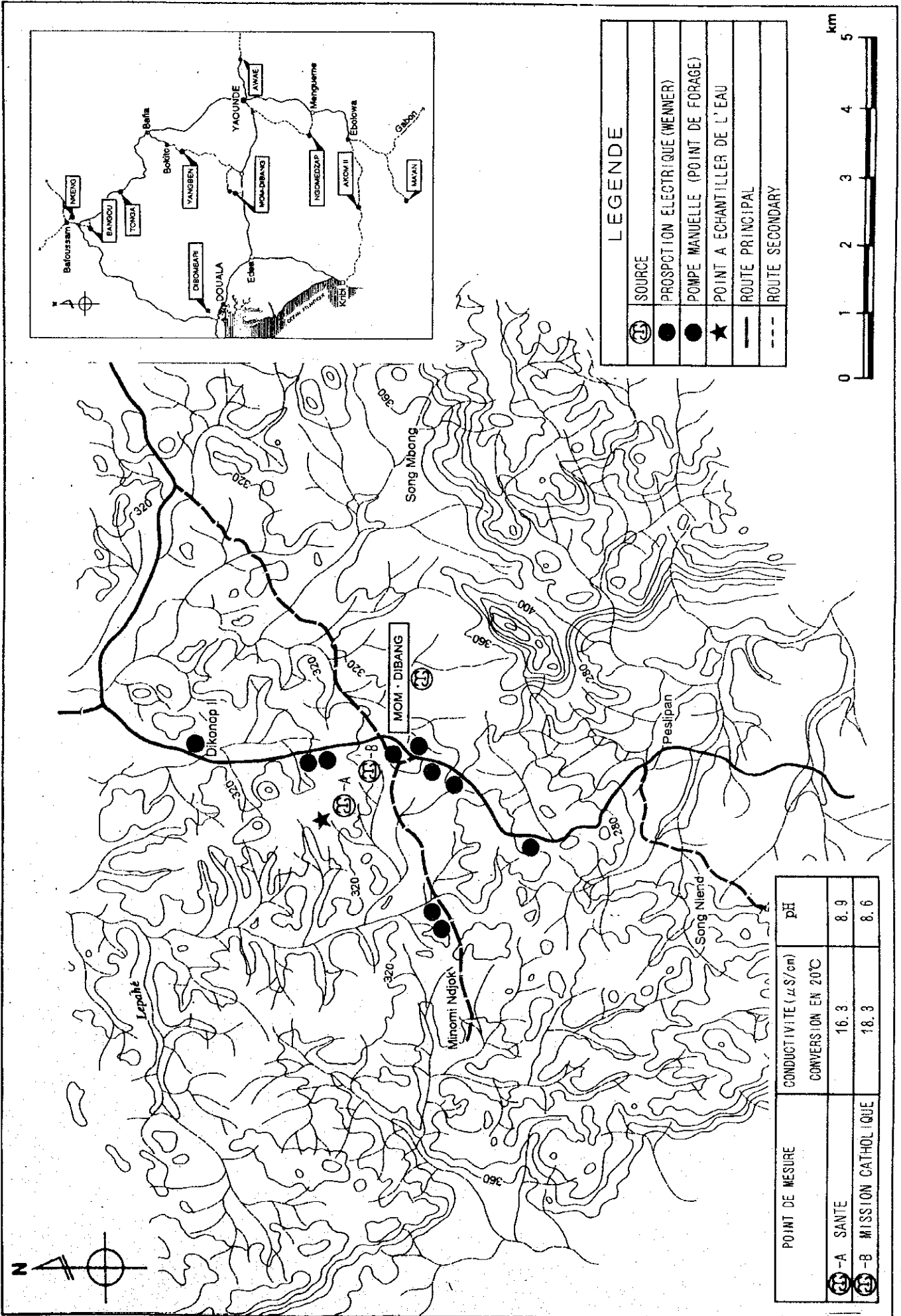

**LEGENDE**

	SOURCE
	PROSPECTION ELECTRIQUE (WENNER)
	POMPE MANUELLE (POINT DE FORAGE)
	POINT A ECHANTILLONNAGE DE L'EAU
	ROUTE PRINCIPAL
	ROUTE SECONDARY



POINT DE MESURE	CONDUCTIVITE ( $\mu S/cm$ )	pH
CONVERSION EN 20°C	16.3	8.9
-A SANTE	18.3	8.6
-B MISSION CATHOLIQUE		



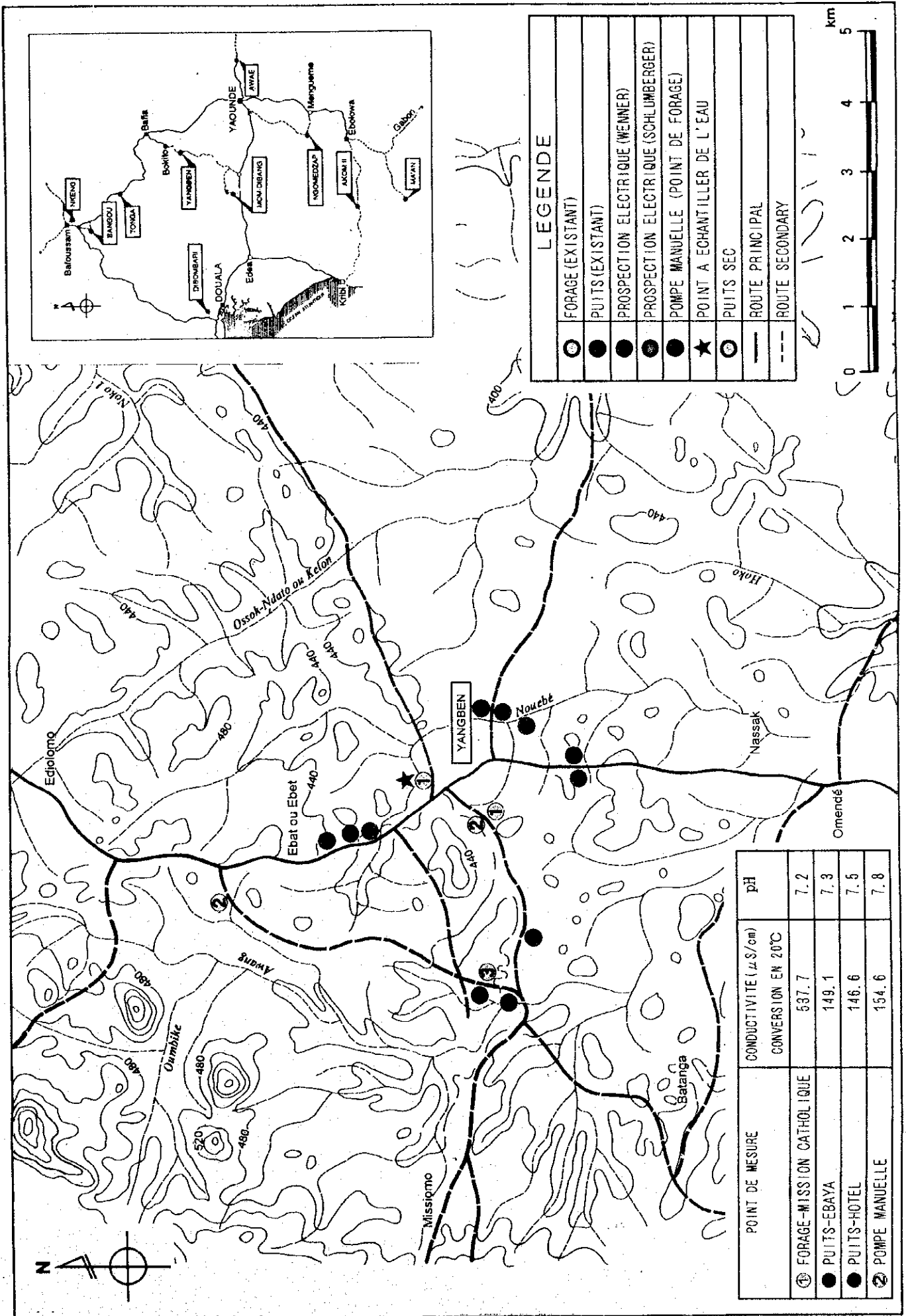

**LEGENDE**

○	FORAGE (EXISTANT)
●	PUITS (EXISTANT)
●	PROSPECTION ELECTRIQUE (WENNER)
●	PROSPECTION ELECTRIQUE (SCHLUMBERGER)
●	POMPE MANUELLE (POINT DE FORAGE)
★	POINT A ECHANTILLER DE L'EAU
○	PUITS SEC
—	ROUTE PRINCIPAL
- - -	ROUTE SECONDARY

POINT DE MESURE	CONDUCTIVITE ( $\mu S/cm$ )	pH
	CONVERSION EN 20°C	
① FORAGE-MISSION CATHOLIQUE	537.7	7.2
● PUIITS-EBAYA	149.1	7.3
● PUIITS-HOTEL	146.6	7.5
② POMPE MANUELLE	154.6	7.8



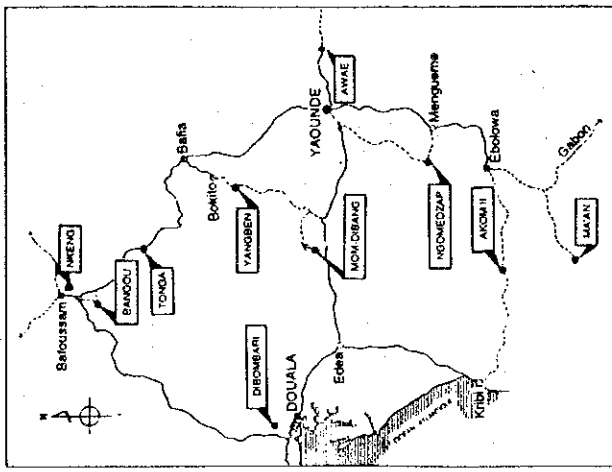
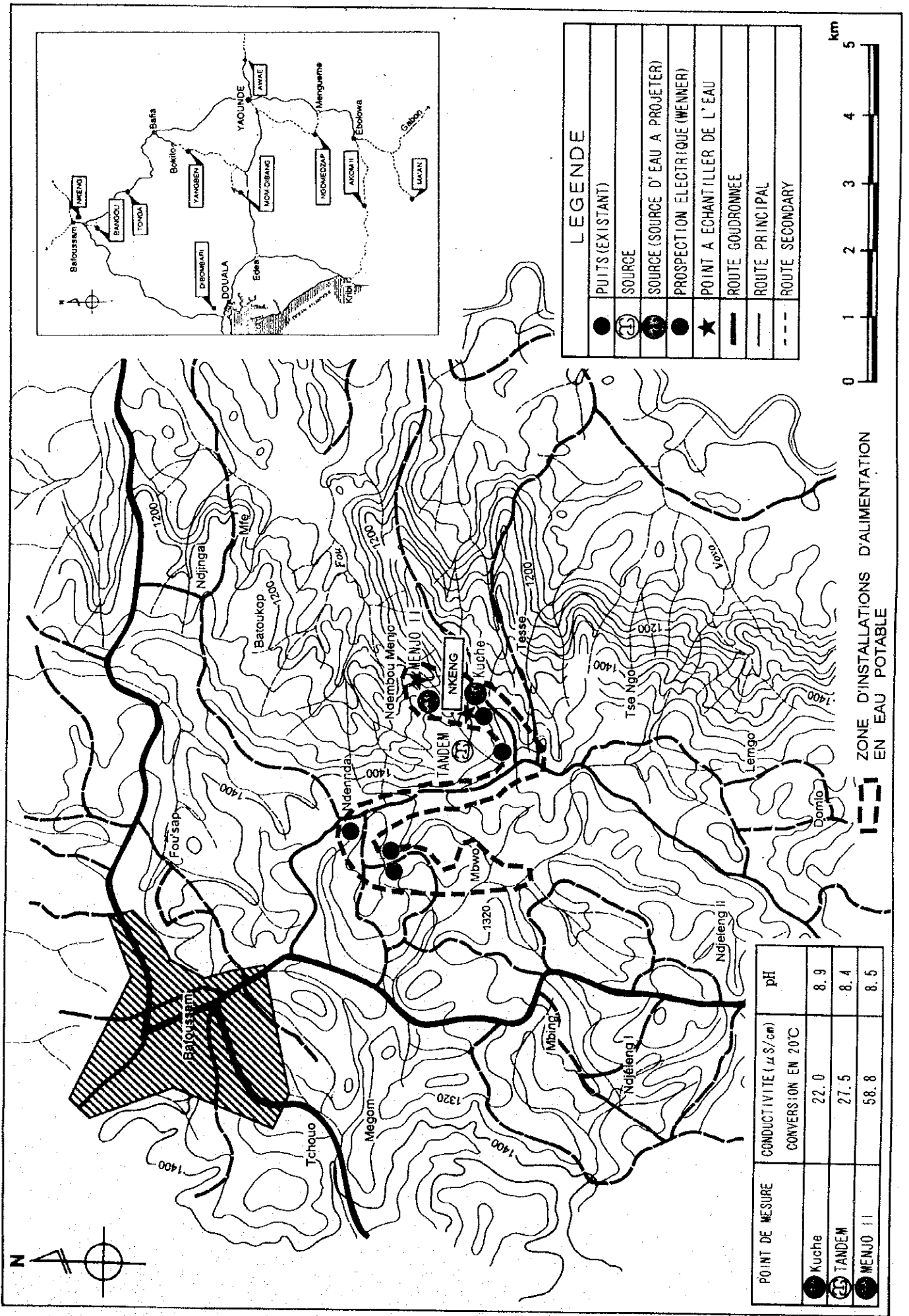

**LEGENDE**

●	PUITS (EXISTANT)
⊕	SOURCE
⊗	SOURCE (SOURCE D'EAU A PROJETER)
●	PROSPECTION ELECTRIQUE (WENNER)
★	POINT A ECHANTILLONNAGE DE L'EAU
—	ROUTE GOUDRONNEE
—	ROUTE PRINCIPAL
- - -	ROUTE SECONDARY

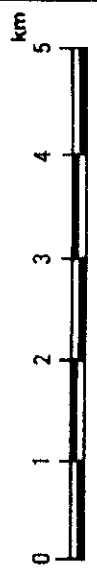

POINT DE MESURE	CONDUCTIVITE (μS/cm) CONVERSION EN 20°C	pH
● Kuche	22.0	8.9
⊕ TANDEM	27.5	8.4
● MENUJO II	58.8	8.5

ZONE D'INSTALLATIONS D'ALIMENTATION EN EAU POTABLE









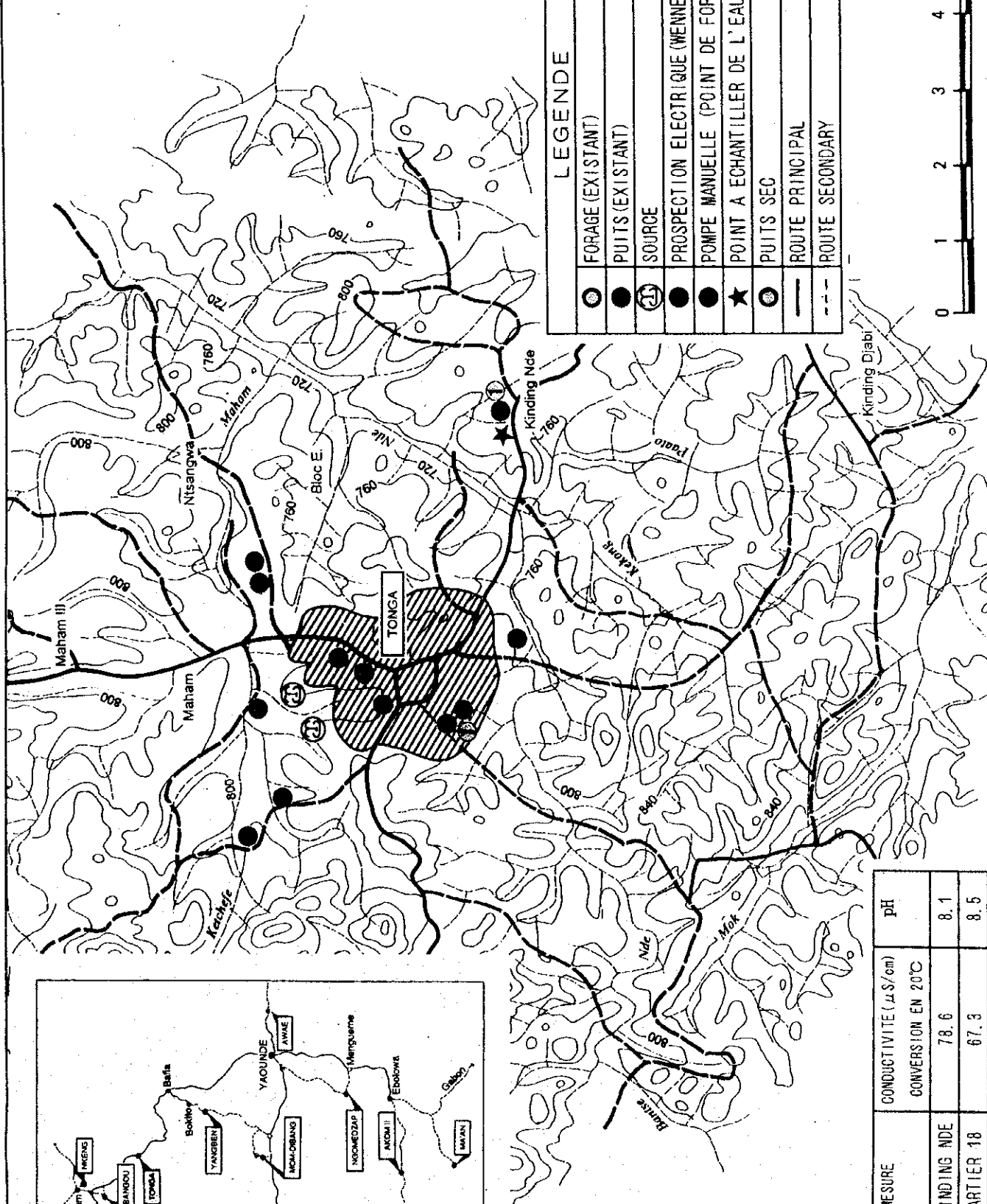
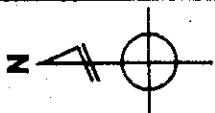

**LEGENDE**

	FORAGE (EXISTANT)
	PUITS (EXISTANT)
	SOURCE
	PROSPECTION ELECTRIQUE (WENNER)
	POMPE MANUELLE (POINT DE FORAGE)
	POINT A ECHANTILLONNAGE DE L'EAU
	PUITS SEC
	ROUTE PRINCIPAL
	ROUTE SECONDARY

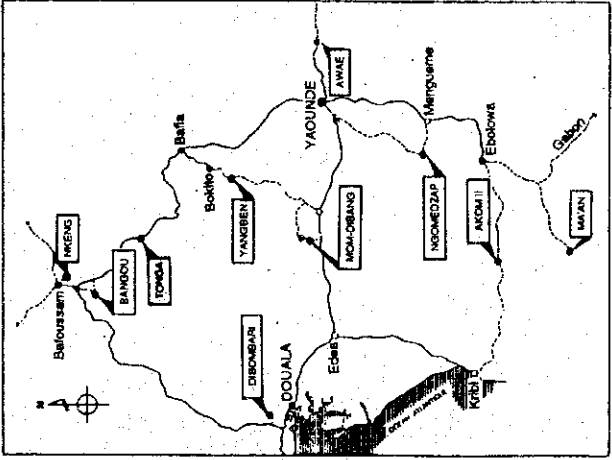

POINT DE MESURE	CONDUCTIVITE ( $\mu S/cm$ )	pH
FORAGE-KINDING NDE	78.6	8.1
A SOURCE CARTIER 18	67.3	8.5



### LEGENDE

●	PUITS (EXISTANT)
⊙	SOURCE
⊙	SOURCE (SOURCE D'EAU A PROJETER)
⊙	PROSPECTION ELECTRIQUE (WENNER)
●	POMPE MANUELLE (POINT DE FORAGE)
★	POINT A ECHANTILLONNAGE DE L'EAU
—	ROUTE PRINCIPAL
---	ROUTE SECONDARY

POINT DE MESURE	CONDUCTIVITE (μS/cm)	pH
● SOURCE (SOURCE D'EAU)	18.2	5.0
● PUIITS-NO. 1	130.4	6.7
● PUIITS-NO. 2	104.2	7.0

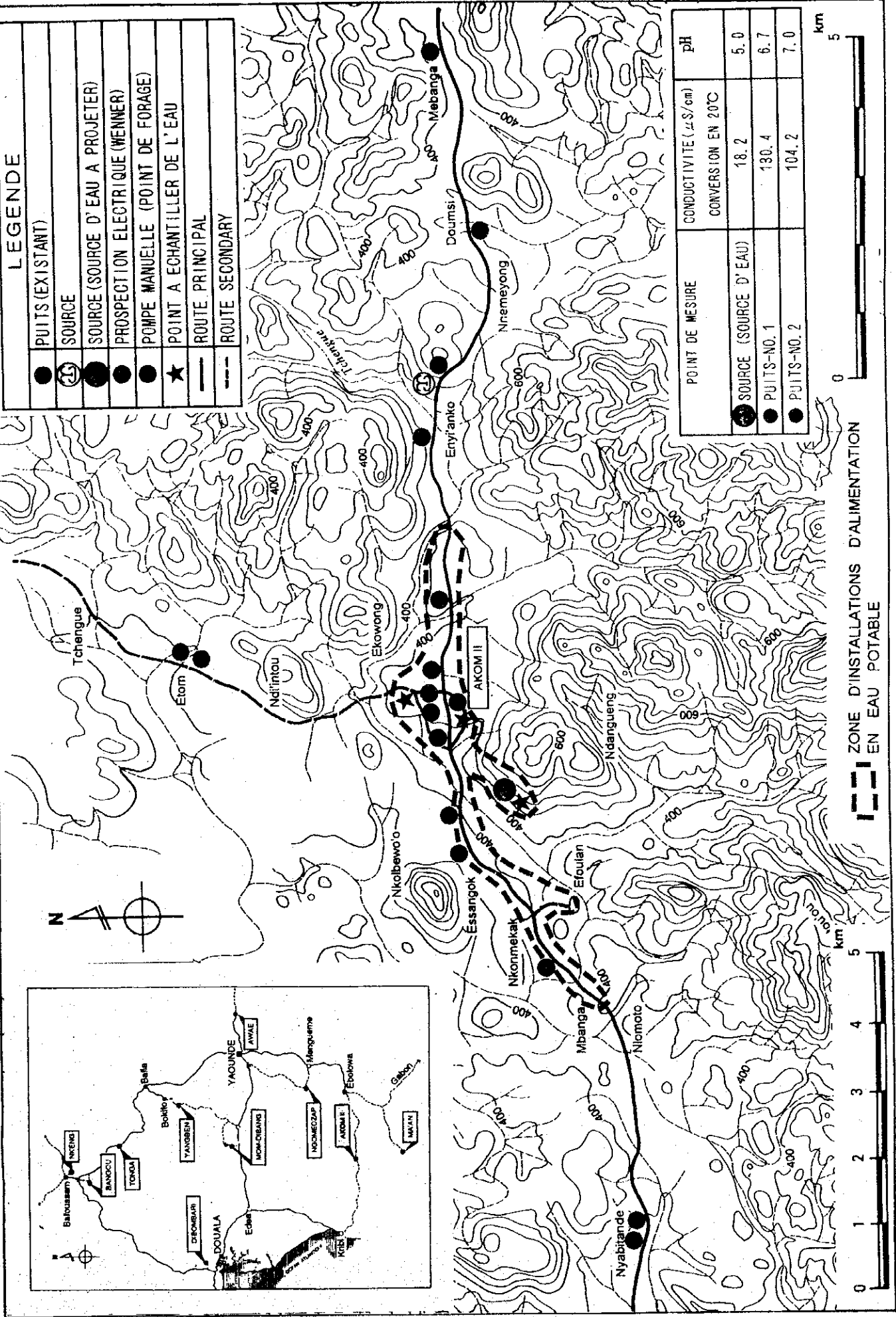
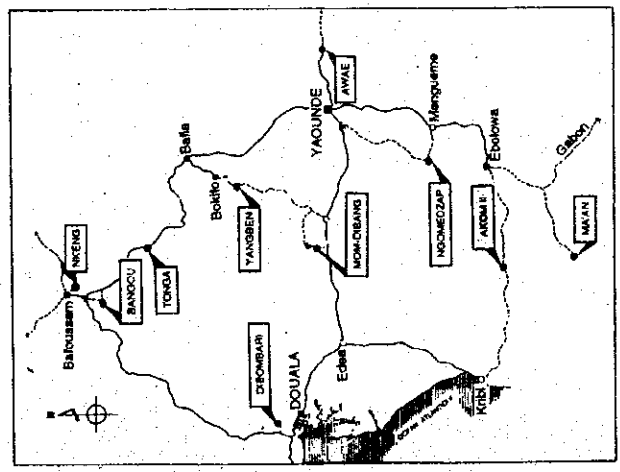

ZONE D'INSTALLATIONS D'ALIMENTATION EN EAU POTABLE



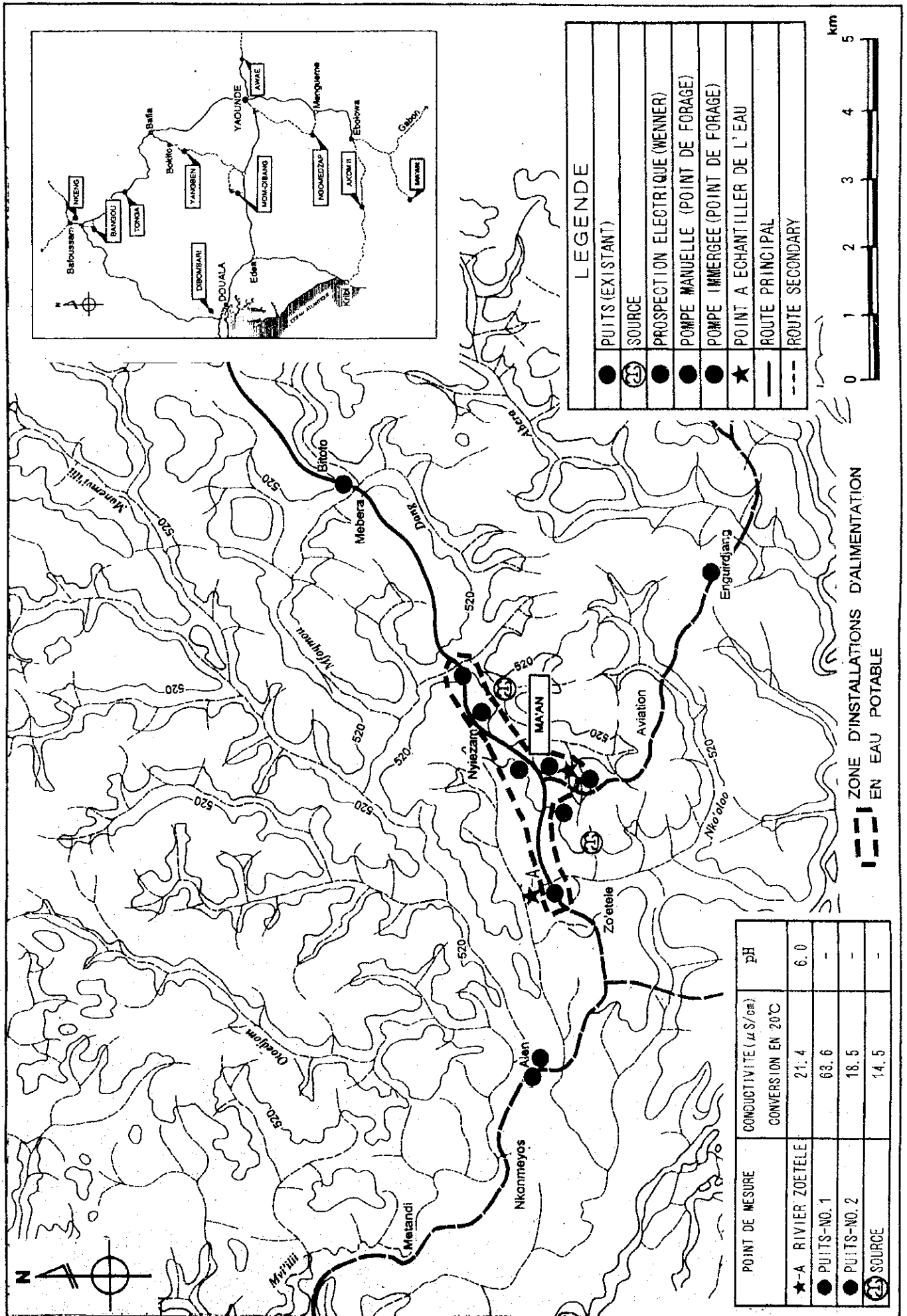

**LEGENDE**

●	PUITS (EXISTANT)
⊗	SOURCE
●	PROSPECTION ELECTRIQUE (WENNER)
●	POMPE MANUELLE (POINT DE FORAGE)
●	POMPE IMMERGEE (POINT DE FORAGE)
★	POINT A ECHANTILLONNAGE DE L'EAU
—	ROUTE PRINCIPAL
- - -	ROUTE SECONDARY

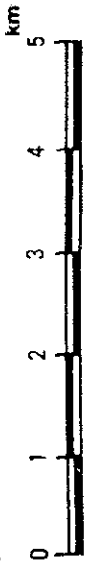

**ZONE D'INSTALLATIONS D'ALIMENTATION EN EAU POTABLE**

POINT DE MESURE	CONDUCTIVITE ( $\mu S/cm$ ) CONVERSION EN 20°C	pH
★-A RIVIER ZOETELE	21.4	6.0
● PUIITS-NO. 1	63.6	-
● PUIITS-NO. 2	18.5	-
⊗ SOURCE	14.5	-





## ANNEX - 7 DESSINS DE CONCEPT DE BASE

1. CABINE DE MACHINERIE - TYPE 1
2. CABINE DE MACHINERIE - TYPE 2
3. CABINE DE MACHINERIE - TYPE 3
4. REHABILITATION DE CABINE DE POMPAGE EXISTANT
5. CHATEAU D'EAU
6. RESERVOIR D'EAU
7. BORNE FONTAINE : 4 ROBINETS - 1
8. BORNE FONTAINE : 4 ROBINETS - 2
9. BORNE FONTAINE : 2 ROBINETS
10. CHAMBRE DE VANNES - 1
11. CHAMBRE DE VANNES - 2
12. PUISARD
13. DETAILS DE PROTECTION ET EXCAVATION.
14. TRAVERSEE DE LA RIVIERE
15. FORAGES EQUIPES DE POMPE MANUELLE

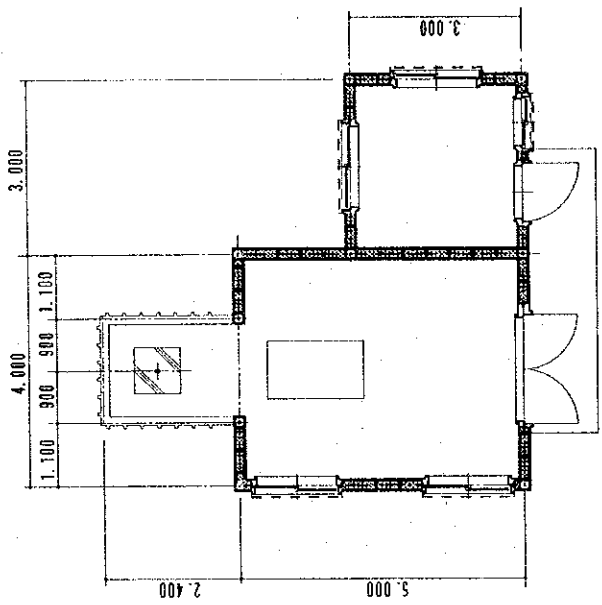

VUE EN PLAN

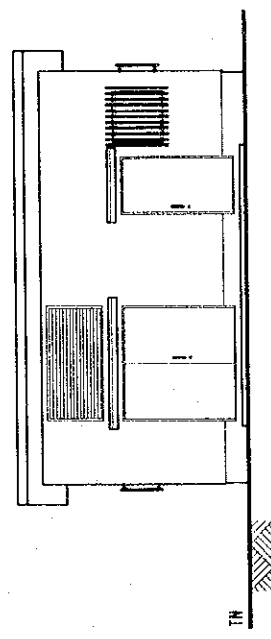

FAÇADE PRINCIPALE

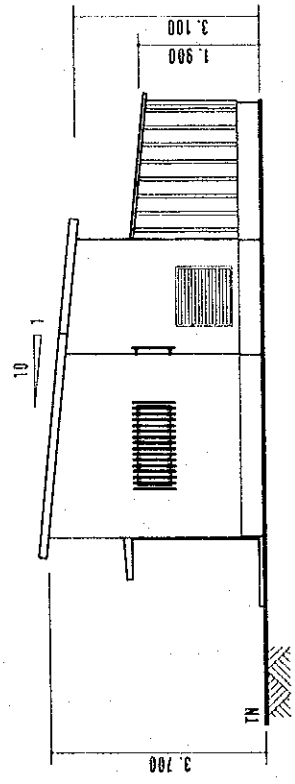

FAÇADE LATÉRALE

CABINE DE MACHINERIE - TYPE 1

APPAREILS DE SÉCURITÉ DIRECTION DE L'AVIATION NAVALE DÉPARTEMENT DES MARCHÉS ET L'ÉQUIPEMENT DE L'ÉQUIPEMENT LE PROJET D'APPROQUIS D'ÉQUIPEMENT EN EAUX DE JETÉE NAVALE	
CHAÎNE DE MACHINERIE - TYPE 1	
<b>DAI</b>	
<b>JAPAN TECHN</b>	

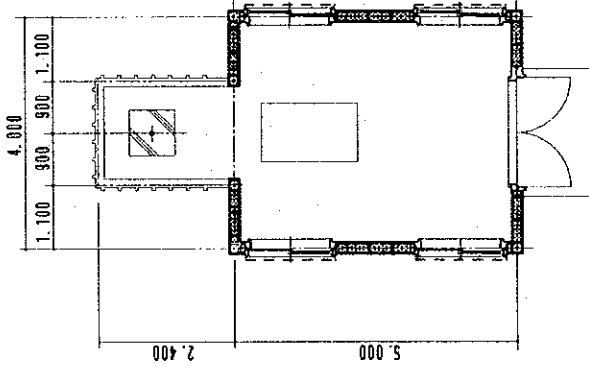

VOIE EN PLAN

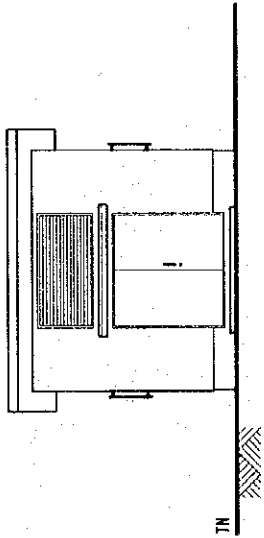

FAÇADE PRINCIPALE

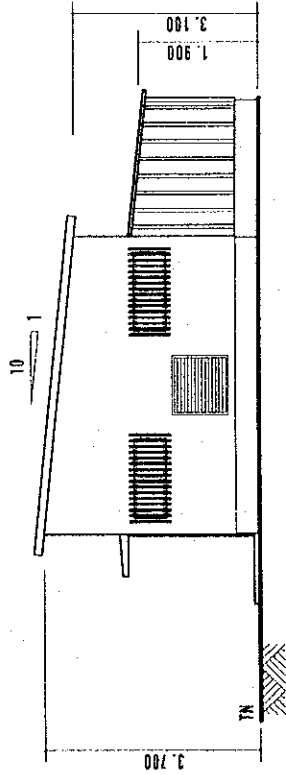

FAÇADE LATÉRALE

CABINE DE MACHINERIE - TYPE 2

DÉPARTEMENT DU CANIÈRE  
 DIRECTOR DE L'HYDROLOGIE R.U.L.L.  
 MINISTÈRE DES TRAVAUX PUBLICS  
 LE PROJET DE L'HYDROLOGIE COMBINAISON EN EAU  
 DE MILLEB SUKAM

CABINE DE MACHINERIE - TYPE 2

**JAPAN TECHNOC**

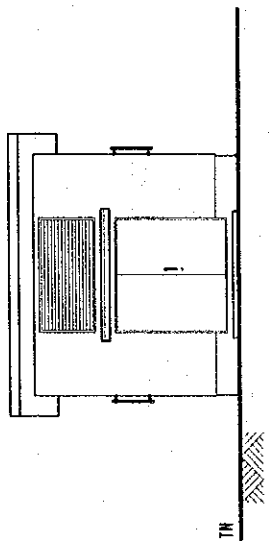

FAÇADE PRINCIPALE

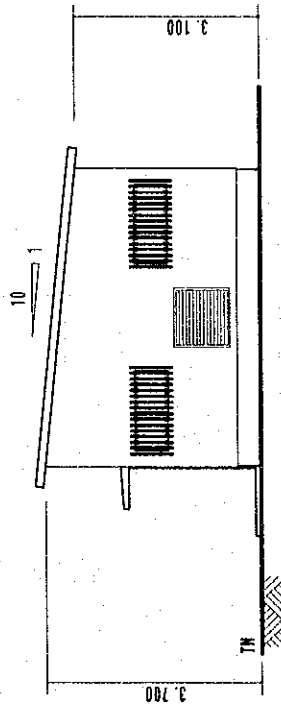

FAÇADE LATÉRALE

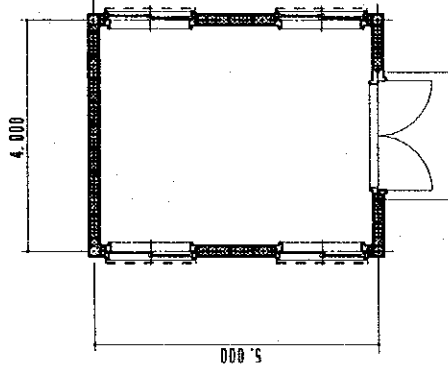

VUE EN PLAN

CABINE DE MACHINERIE - TYPE 3

○	REPARTITION DU TRAVAIL
○	DIRECTION DE MACHINERIE RURAL
○	MINISTRE DES TRAVAIL, DE L'ÉLEVAGE ET DE L'ÉNERGIE
○	LE PROJET D'APPROVISIONNEMENT EN CAD
○	DU MILIEU RURAL
CABINE DE MACHINERIE - TYPE 3	
3	
JAPAN TECHNIO	

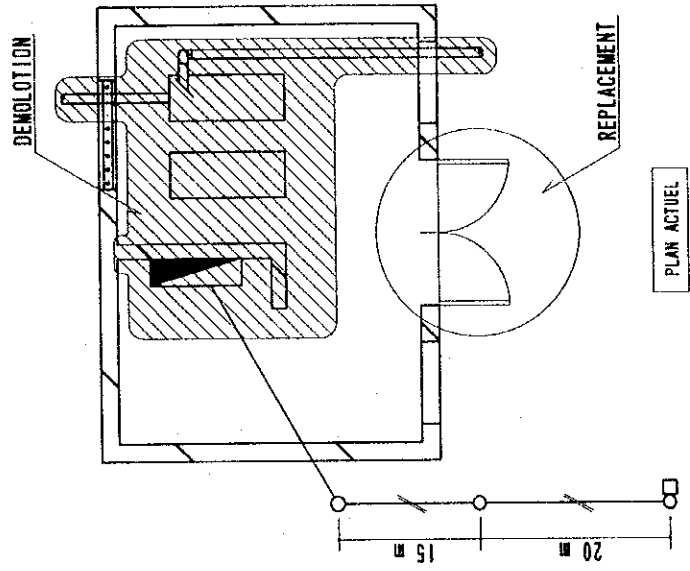
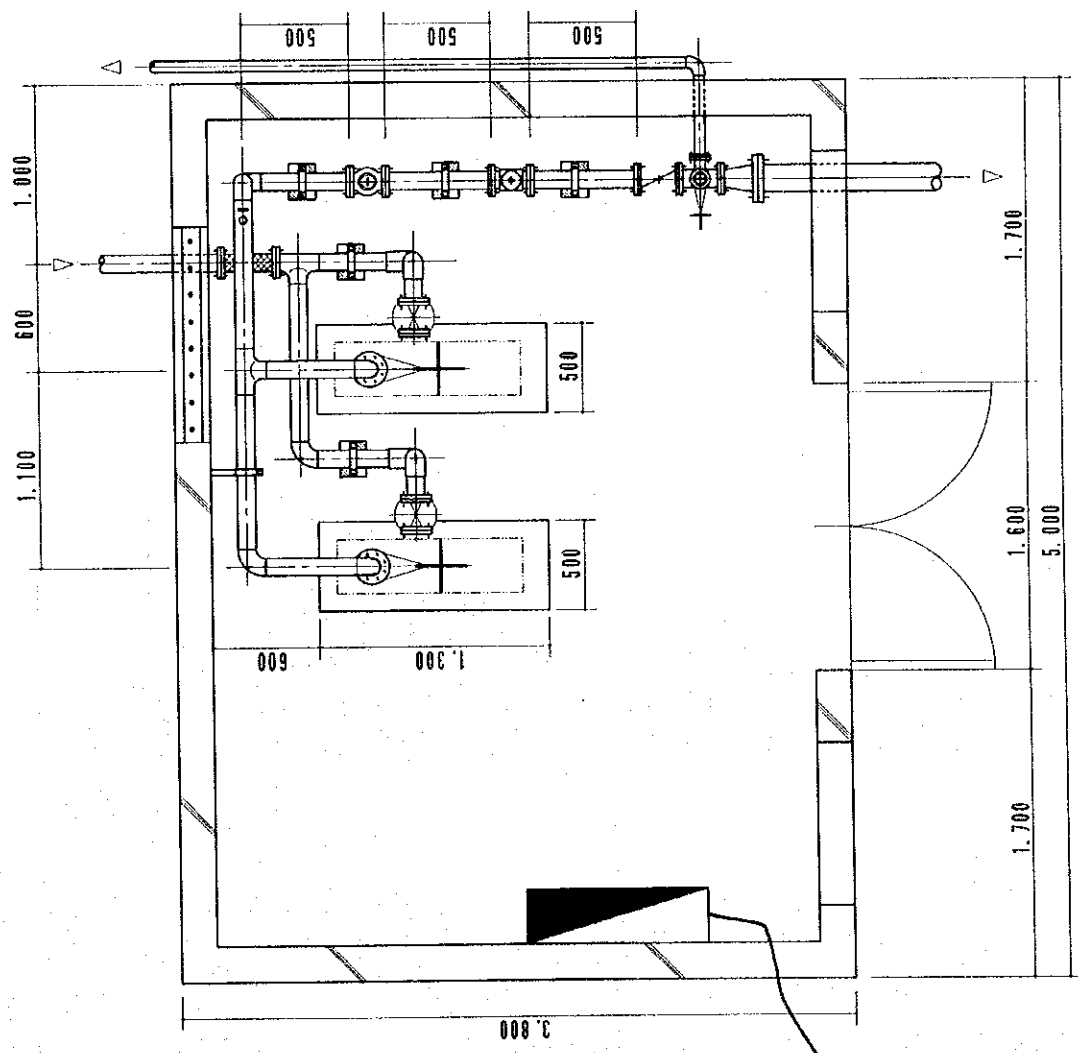

REHABILITATION DE CABINE DE POMPAGE EXISTANT

REPUBLIQUE DU CAMBODGE DIRECTION DE L'INDUSTRIE REHAL MINISTRE DES TRAV. ET L'ENFANT LE PROJET DE REHABILITATION EN EN OU MILIEU REHAL	REHABILITATION DE DE CABINE DE POMPAGE EXISTANT	
		JAPAN TECHNO

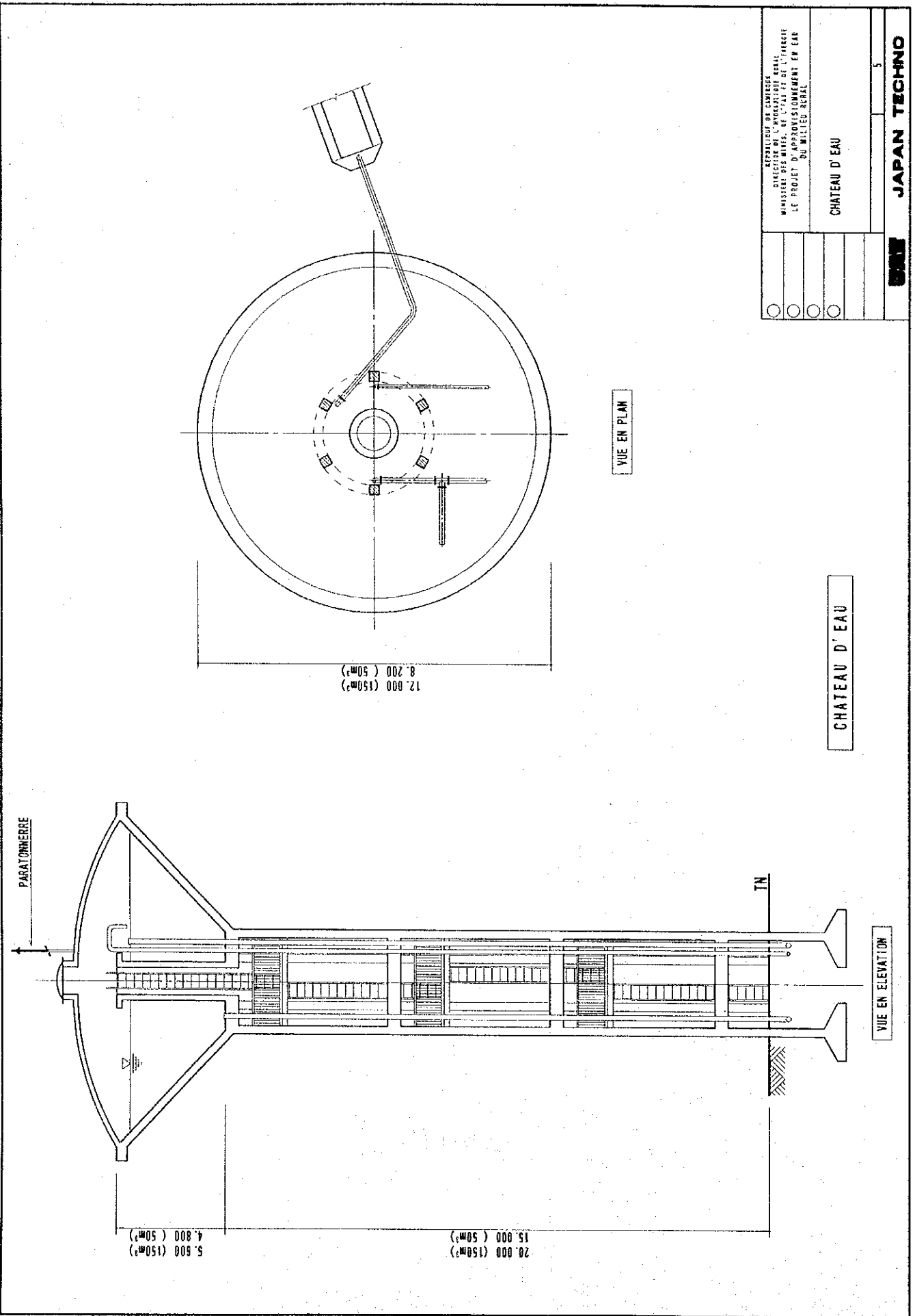

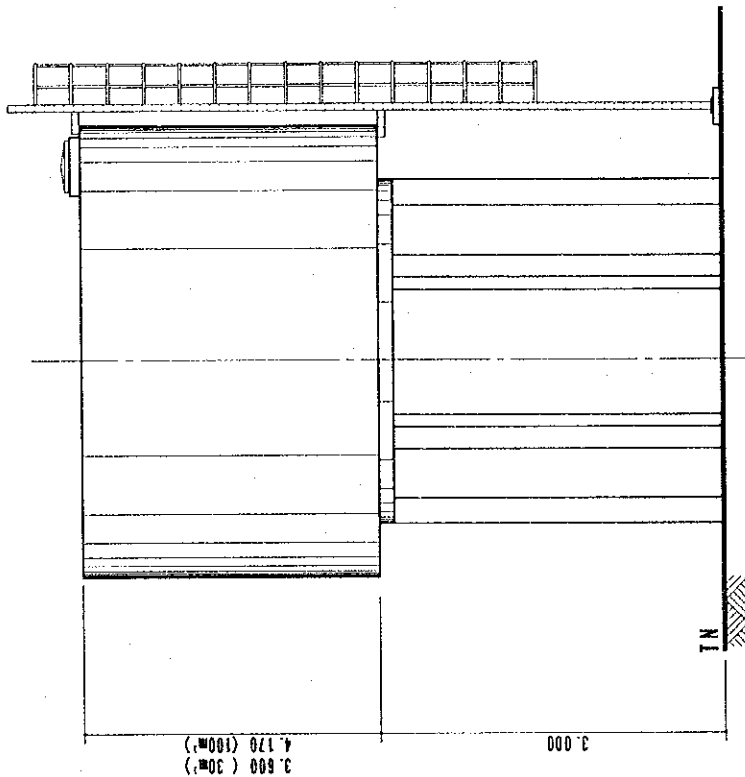

FACADE

3.000  
4.170 (100m<sup>2</sup>)  
3.600 (30m<sup>2</sup>)

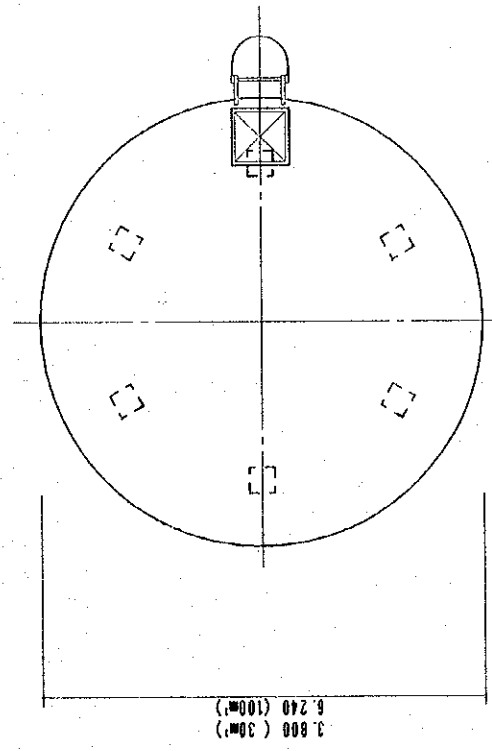

VUE EN PLAN

3.600 (30m)  
6.240 (100m<sup>2</sup>)

REPUBLIQUE DE CAMEROUN DIRECTION DE L'AMPLIQUOT NORD MINISTERE DES MINES, DE L'ENERGIE ET DE L'INDUSTRIE LE PROJET D'AMPLIQUOT NORD	
RESERVOIR D'EAU	
6	
<b>JAPAN TECHNO</b>	

RESERVOIR D'EAU

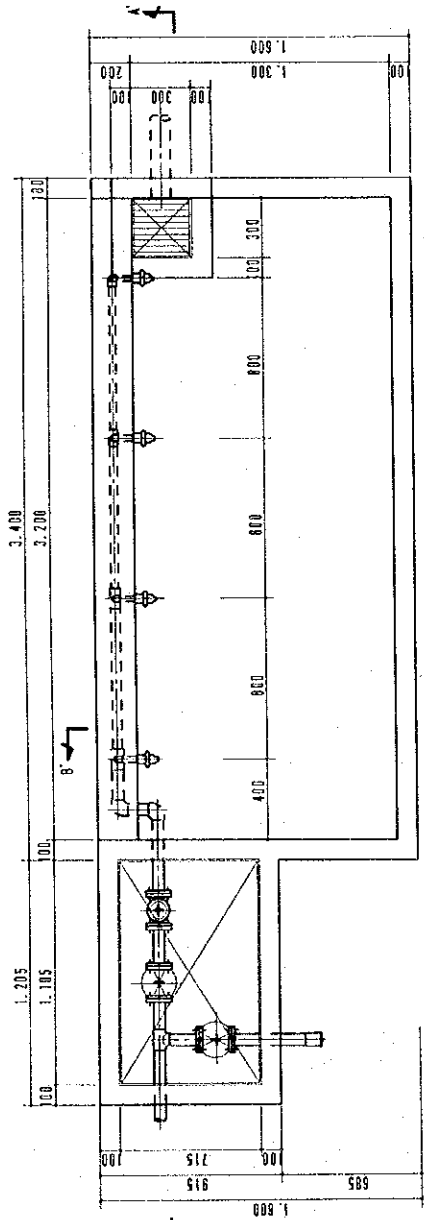

VUE EN PLAN

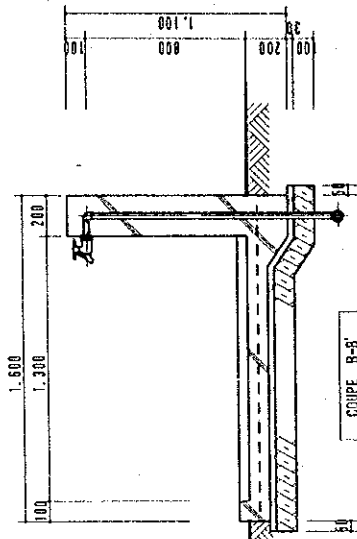

COUPE B-B

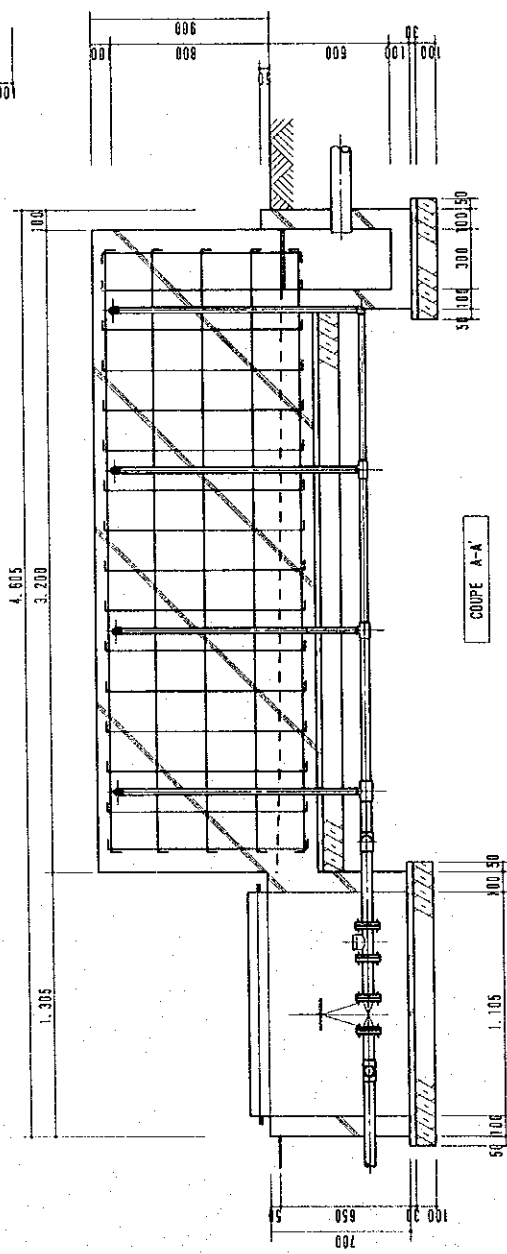

COUPE A-A

BORNE FONTAINE : 4 ROBINETS - 1

<p>LE MINISTRE DU LOGEMENT          DIRECTORAT GÉNÉRAL D'ÉQUIPEMENT RURAL          MINISTÈRE DES MINES, DE L'ÉNERGIE ET DE L'ÉNERGIE          LE PROJET D'APPROVISIONNEMENT EN EAU          DU MILIEU RURAL</p>	<p>BORNE FONTAINE : 4 ROBINETS - 1</p>
<p><b>JAPAN TECHNO</b></p>	<p>1</p>



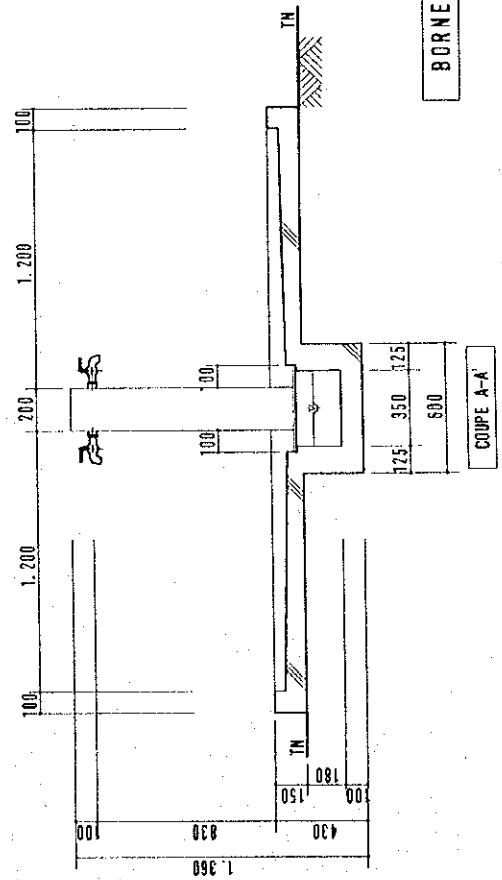
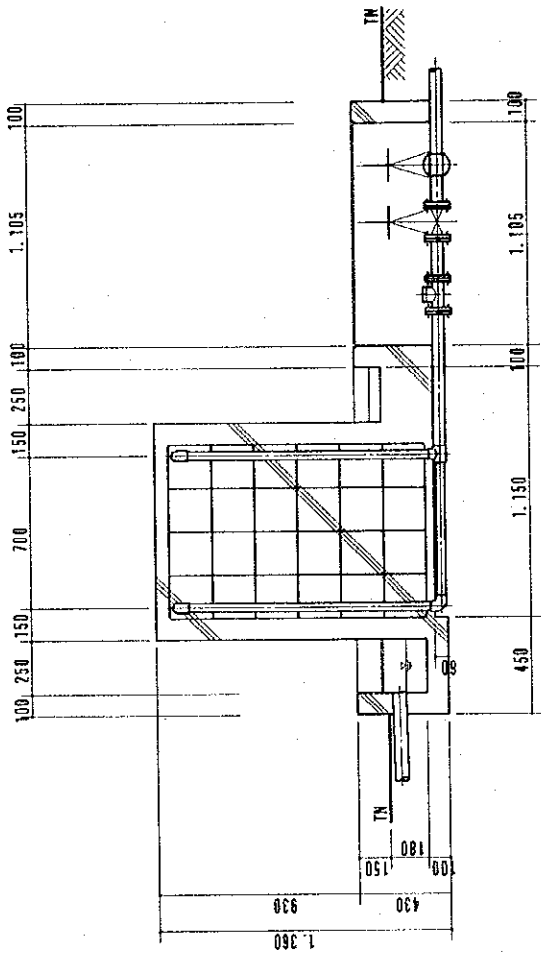
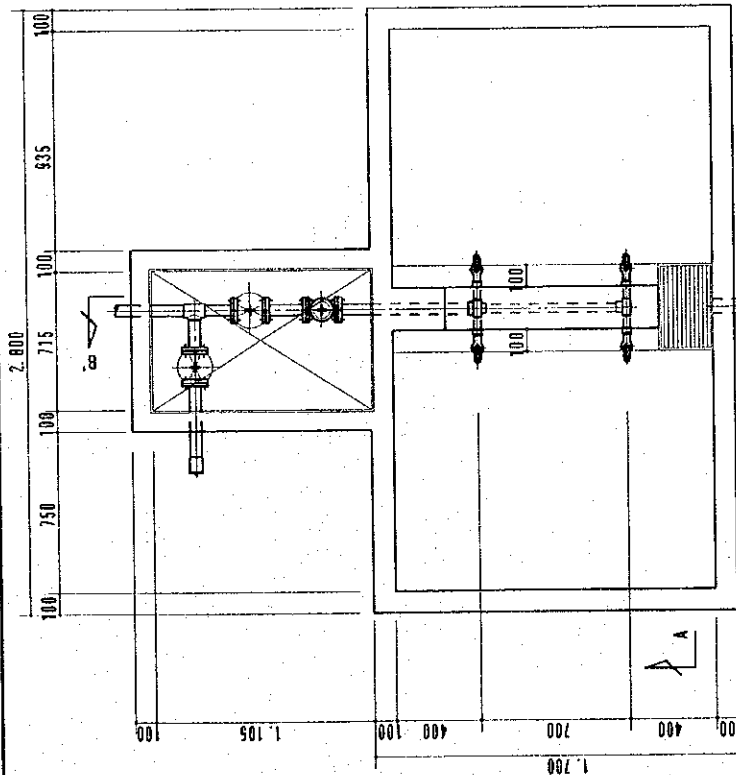

BORNE FONTAINE : 4 ROBINETS - 2

REPUBLIQUE DU CAMBODGE  
 DIRECTION DE L'INDUSTRIE AERIE  
 MINISTERE DES TRAVAUX, DE L'ENERGIE ET DE L'ELECTRICITE  
 LE PROJET D'APPROVISIONNEMENT EN EAU  
 DU VILLET ROYAL

BORNE FONTAINE : 4 ROBINETS - 2

**JAPAN TECHNICO**

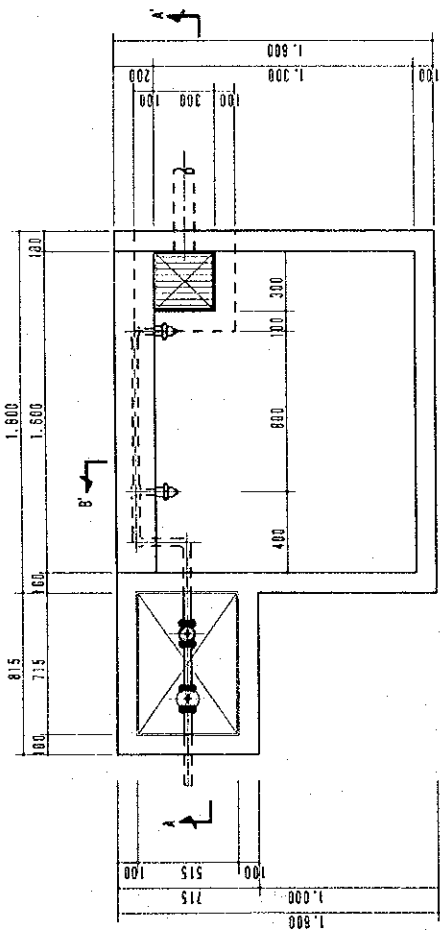

VUE EN PLAN

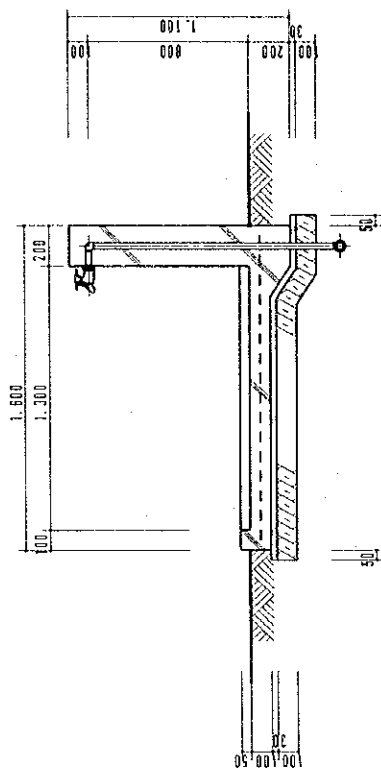

COUPE B - B'

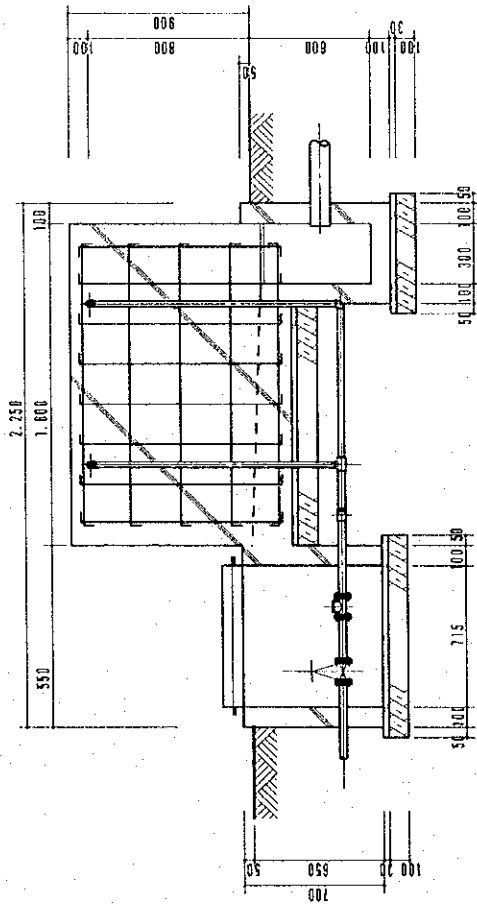

COUPE A - A'

BORNE FONTAINE : 2 ROBINETS

RÉPUBLIQUE DE CAMBODGE DIRECTEUR DE L'HYDRAULIQUE AÉRIEN MINISTÈRE DES TRAVAIX, DE L'ÉNERGIE ET DE L'ÉLECTRICITÉ LE PROJET D'APPARTEILLEMENT EN EAUX DU WATLEU AÉRIEN	
BORNE FONTAINE : 2 ROBINETS	
<b>JAPAN TECHNO</b>	

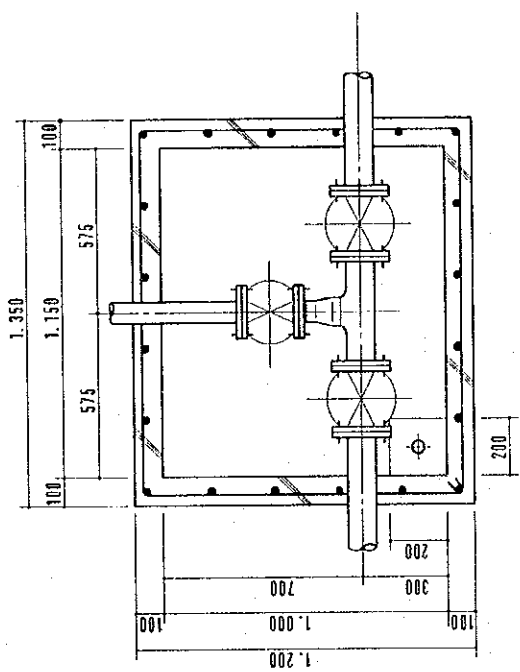

VUE EN PLAN

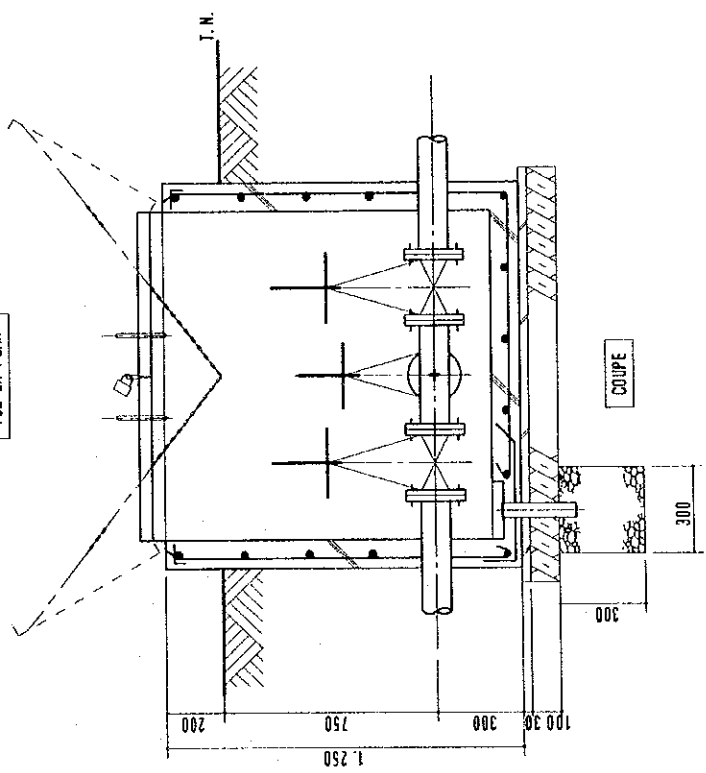

CHAMBRE DE VANNES - 1

REPEREUSE DE CHARGES MUNICIPALITE DE LA VILLE DE NANTES MUNICIPALITE DE LA VILLE DE NANTES LE PROJET D'APPROVISIONNEMENT EN EAU DU MILIEU RURAL	19
CHAMBRE DE VANNES - 1	
<b>JAPAN TECHNICO</b>	

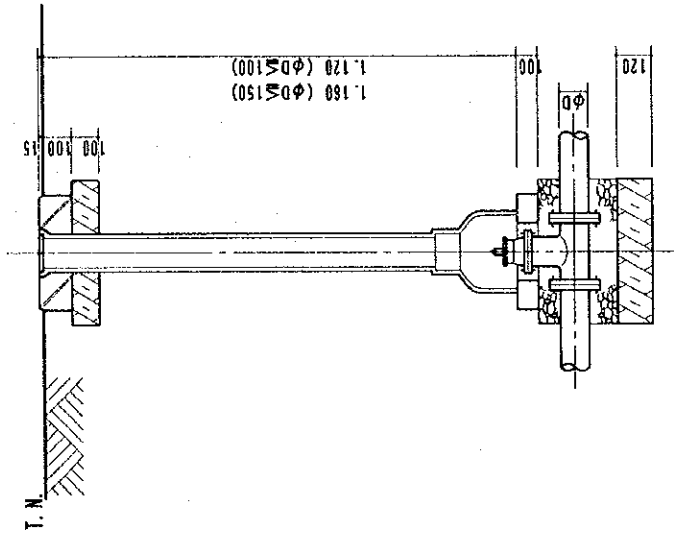
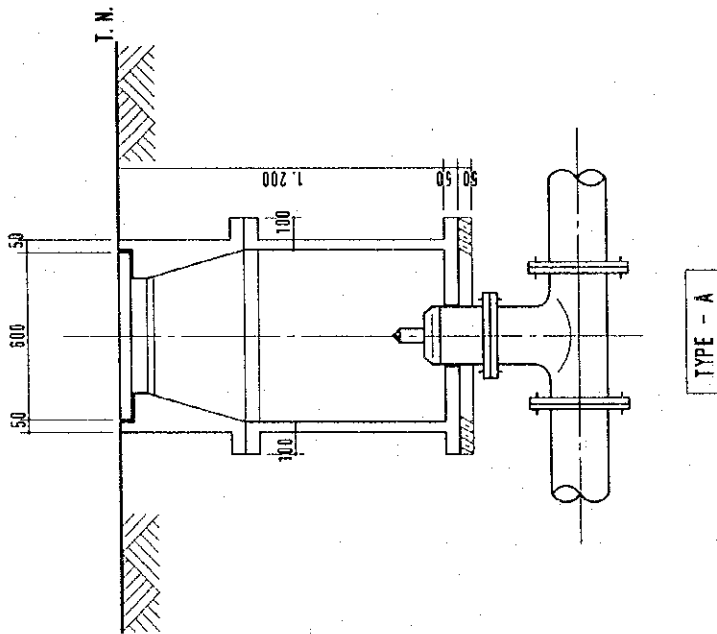

TYPE - B

TYPE - A

CHAMBRE DE VANNES - 2

MINISTÈRE DU GÉNÉRIER BUREAU DE L'INDUSTRIE NIPON MINISTÈRE DES MINES, DE L'EAU ET DE L'ÉNERGIE LE PROJET D'APPROVISIONNEMENT EN EAU DU MILIEU NIPON	
CHAMBRE DE VANNES - 2	
11	
 <b>JAPAN TECHNO</b>	

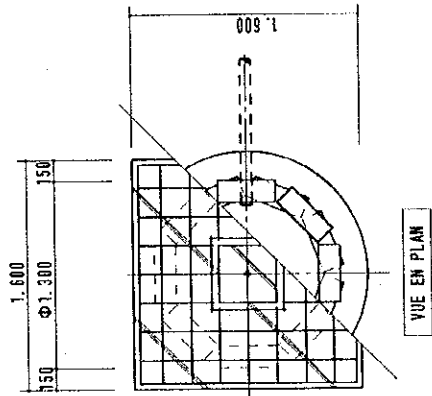

VUE EN PLAN

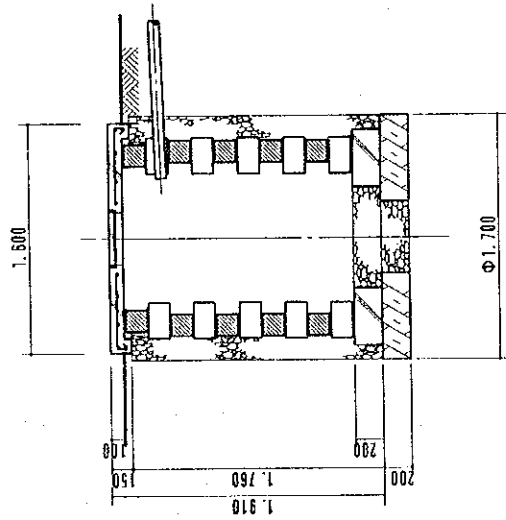

COUPE

PUISARD POUR BORNE FONTAINE

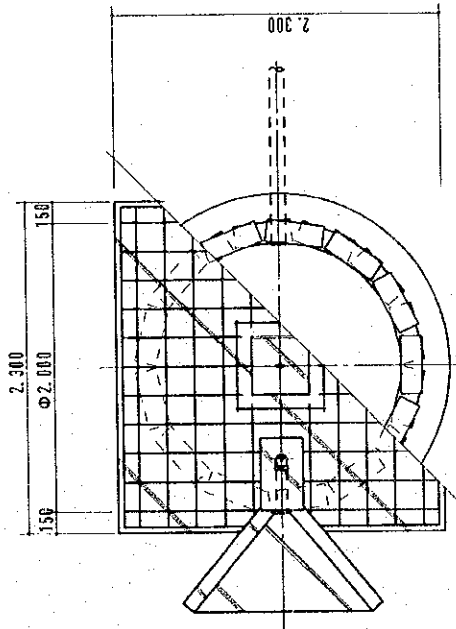

VUE EN PLAN

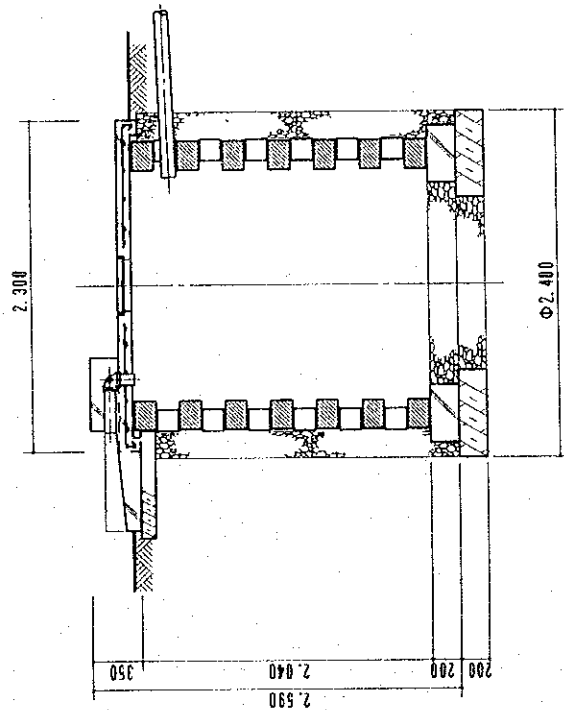

COUPE

PUISARD POUR RESERVOIR

LE PROJET DE CONSTRUCTION DE LA BORNES FONTAINES INDUSTRIELLES DES VILLES DE L'ÉTAT ET L'ÉNERGIE LE PROJET D'APPROVISIONNEMENT EN EAU LE PROJET DU VILLAGE RURAL	
○	
○	
○	
○	
<b>PUISARD</b>	
<b>JAPAN TECHNO</b>	
12	

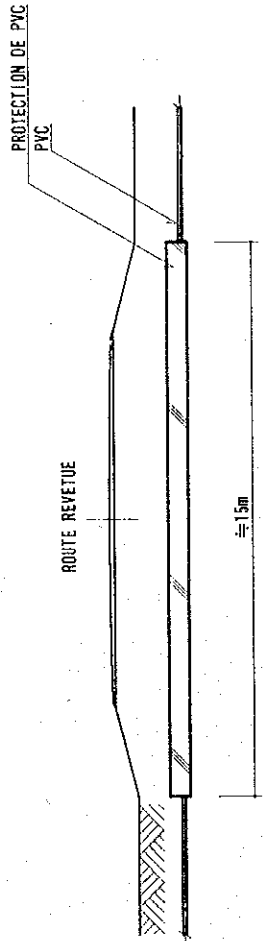
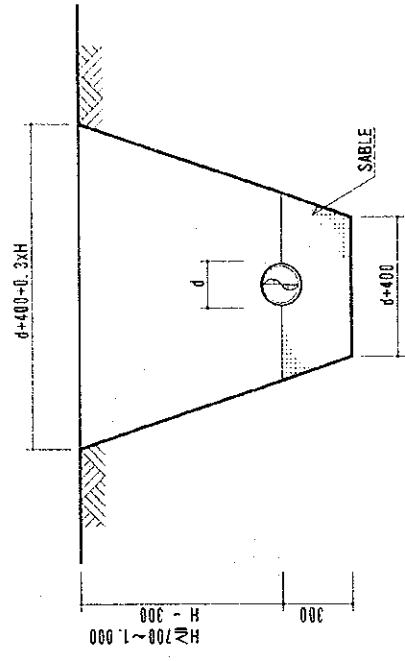
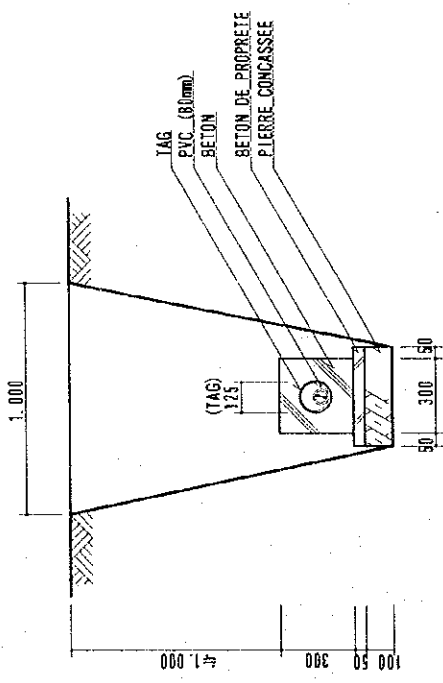

EXCAVATION

DETAILS DE PROTECTION ET EXCAVATION  
(TRAVERSEMENT DE ROUTE REVETUE)

REPUBLIQUE DU CAMBODGE	
ROYAUME DU CAMBODGE	
MINISTERE DES TRAVUX PUBLICS	
LE PROJET D'AMBISSONNEMENT EN EAU	
DU MILIEU RURAL	
DETAILS DE PROTECTION ET EXCAVATION	
	13

**JAPAN TECHN**

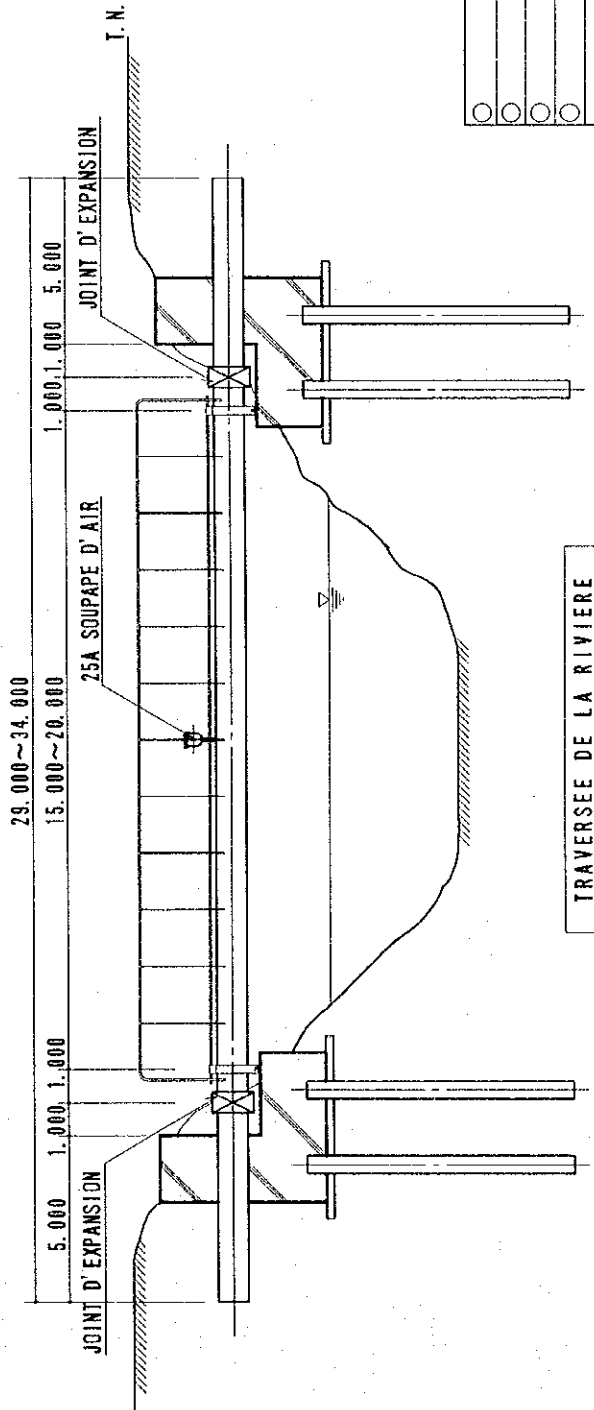
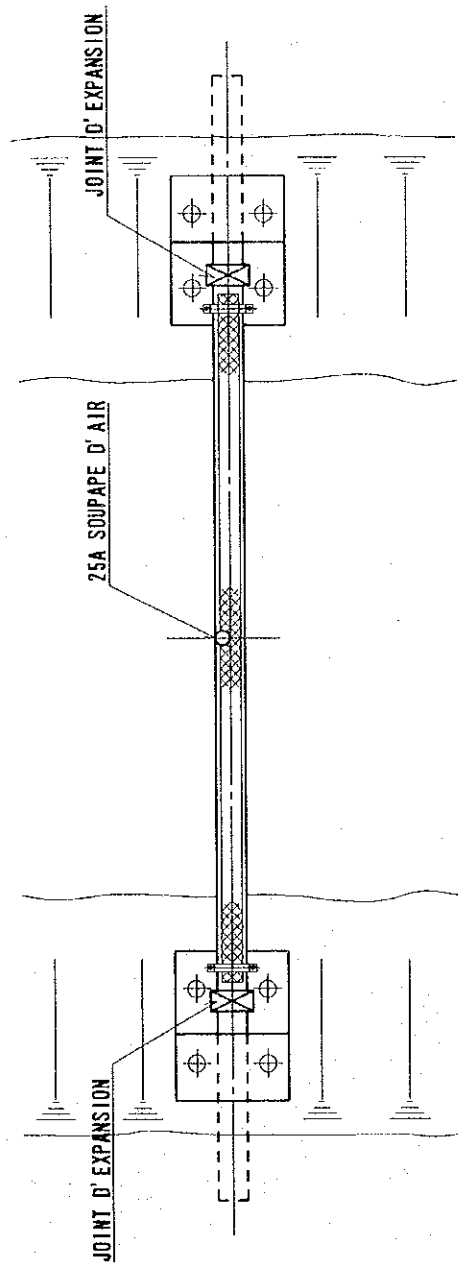

TRAVERSEE DE LA RIVIERE

APPAREILS DE SERRURE  
 DANS LES TUBES EN ACIER  
 MINISTRE DES TRAVAIUX PUBLICS  
 LE PROJET D'APPROVISIONNEMENT EN EAU  
 DU MILLIEU RURAL

TRAVERSEE DE LA RIVIERE

14

**JAPAN TECHN**

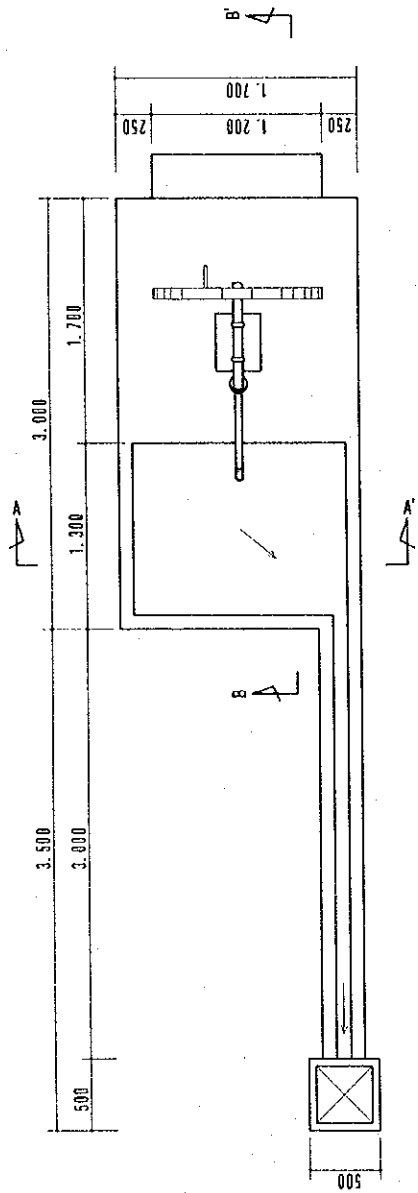

VUE EN PLAN

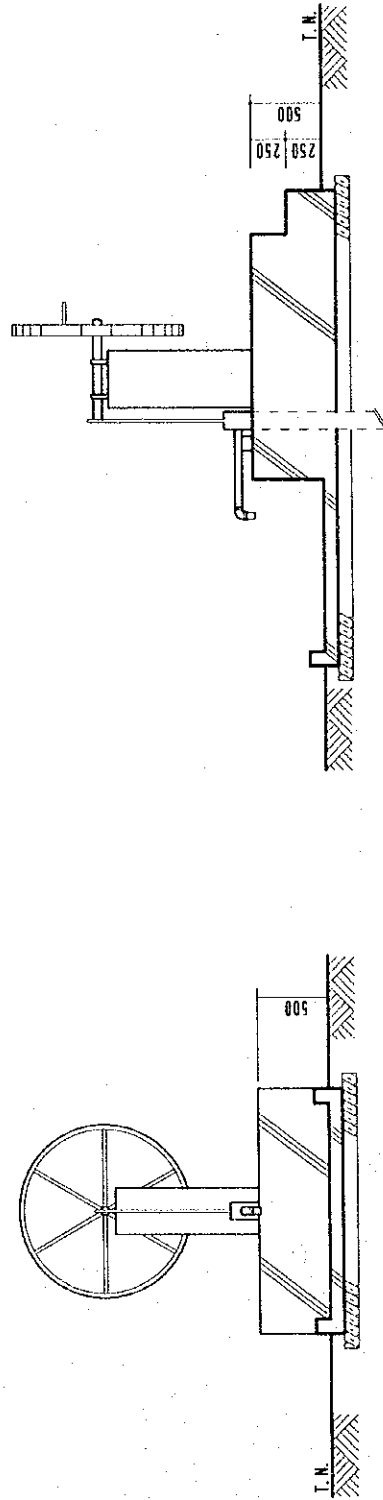

COUPE A-A

COUPE B-B

FORAGES EQUIPES DE POMPE MANUELLE

MINISTRE DE L'INDUSTRIE ET DU COMMERCE DIRECTION DE L'HYDRAULIQUE RURALE MINISTRE DES MINES, DE L'ENERGIE ET DE L'ENERGIE LE PROJET D'APPROVISIONNEMENT EN EAU DU MILIEU RURAL	
FORAGES EQUIPES DE POMPE MANUELLE	
15	
<b>JAPAN TECHNO</b>	



1. DIBOMBARI		1	2	3	4	5	6	7	8	9	10
A N N E E											
a.	POPULATION DESSERVIE	6, 150	6, 320	6, 490	6, 670	6, 850	7, 030	7, 220	7, 410	7, 610	7, 820
b.	DEBIT MOYENNE (m <sup>3</sup> /jour)	154	158	162	167	171	176	181	185	190	196
c.	HEURES DE POMPAGE (Hr/jour)	6	7	7	7	7	7	8	8	8	8
d.	DEPENSE										
	1) CARBURANT ELECTRICITE (FCFA)	1, 752, 000	1, 806, 750	1, 861, 500	1, 916, 250	1, 943, 625	1, 998, 375	2, 053, 125	2, 107, 875	2, 162, 625	2, 244, 750
	2) CONSOMMABLE (FCFA)	52, 560	54, 203	55, 845	57, 488	58, 309	59, 951	61, 594	63, 236	64, 879	67, 343
	3) SALAIRE DE L' OPERATEUR (FCFA)	600, 000	600, 000	600, 000	600, 000	600, 000	600, 000	600, 000	600, 000	600, 000	600, 000
	4) HONORAIRES DU REPARATEUR (FCFA)	158, 220	162, 540	166, 860	171, 540	176, 220	180, 720	185, 580	190, 620	195, 660	201, 060
	5) PRAISE ADMINISTRATIF (FCFA)	263, 700	270, 900	278, 100	285, 900	293, 700	301, 200	309, 300	317, 700	326, 100	335, 100
	DEPENSE-TOTAL	2, 826, 480	2, 894, 393	2, 962, 305	3, 031, 178	3, 071, 854	3, 140, 246	3, 209, 599	3, 279, 431	3, 349, 264	3, 448, 253
e.	REVENUE										
	NOMBRE DE MENAGES	879	903	927	953	979	1, 004	1, 031	1, 059	1, 087	1, 117
	TARIF DE L' EAU										
	FCFA500/MENAGE/MOIS	5, 274, 000	5, 418, 000	5, 562, 000	5, 718, 000	5, 874, 000	6, 024, 000	6, 186, 000	6, 354, 000	6, 522, 000	6, 702, 000
f.	BILAN (FCFA)	+2, 447, 520	+2, 523, 607	+2, 599, 695	+2, 686, 822	+2, 802, 146	+2, 883, 754	+2, 976, 401	+3, 074, 569	+3, 172, 736	+3, 253, 747

2. AWAE

A N N E E	1	2	3	4	5	6	7	8	9	10
a. POPULATION DESSERVIE	3, 500	3, 570	3, 640	3, 710	3, 780	3, 860	3, 940	4, 020	4, 100	4, 180
b. DEBIT MOYENNE (m <sup>3</sup> /jour)	88	89	91	93	95	97	99	101	103	105
c. HEURES DE POMPAGE (Hr/jour)	6	6	6	6	6	7	7	7	7	7
d. DEPENSE										
1) CARBURANT ELECTRICITE (FCFA)	1, 399, 775	1, 399, 775	1, 447, 225	1, 470, 950	1, 494, 675	1, 542, 125	1, 565, 850	1, 589, 575	1, 637, 025	1, 660, 750
2) CONSOMMABLE (FCFA)	41, 993	41, 993	43, 417	44, 129	44, 840	46, 264	46, 976	47, 687	49, 111	49, 823
3) SALAIRE DE L' OPERATEUR (FCFA)	600, 000	600, 000	600, 000	600, 000	600, 000	600, 000	600, 000	600, 000	600, 000	600, 000
4) HONORAIRES DU REPARATEUR (FCFA)	90, 000	91, 800	93, 600	95, 400	97, 200	99, 180	101, 340	103, 320	105, 480	107, 460
5) FRAISE ADMINISTRATIF (FCFA)	150, 000	153, 000	156, 000	159, 000	162, 000	165, 300	168, 900	172, 200	175, 800	179, 100
DEPENSE-TOTAL	2, 281, 768	2, 286, 568	2, 340, 242	2, 369, 479	2, 398, 715	2, 452, 869	2, 483, 066	2, 512, 782	2, 567, 416	2, 597, 133
e. REVENUE										
NOMBRE DE MENAGES	500	510	520	530	540	551	563	574	586	597
TARIF DE L' EAU										
FCFA500/MENAGE/MOIS	3, 000, 000	3, 060, 000	3, 120, 000	3, 180, 000	3, 240, 000	3, 306, 000	3, 378, 000	3, 444, 000	3, 516, 000	3, 582, 000
f. BILAN (FCFA)	+718, 232	+773, 432	+779, 758	+810, 521	+841, 285	+853, 131	+894, 934	+931, 218	+948, 584	+984, 867

3. NKENG

A N N E E		1	2	3	4	5	6	7	8	9	10
a. POPULATION DESSERVIE		4,500	4,620	4,740	4,860	4,990	5,120	5,250	5,390	5,530	5,670
b. DEBIT MOYENNE (m <sup>3</sup> /jour)		113	116	119	122	125	128	131	135	138	142
c. HEURES DE POMPAGE (Hr/jour)		9	10	10	10	10	11	11	11	12	12
d. DEPENSE											
1) CARBURANT ELECTRICITE (FCFA)		2,182,116	2,251,758	2,298,186	2,367,828	2,414,256	2,483,898	2,530,326	2,623,182	2,669,610	2,739,252
2) CONSOMMABLE (FCFA)		65,463	67,553	68,946	71,035	72,428	74,517	75,910	78,695	80,088	82,178
3) SALAIRE DE L'OPERATEUR (FCFA)		600,000	600,000	600,000	600,000	600,000	600,000	600,000	600,000	600,000	600,000
4) HONORAIRES DU REPARATEUR (FCFA)		115,740	118,800	121,860	124,920	128,340	131,580	135,000	138,600	142,200	145,800
5) FRAISE ADMINISTRATIF (FCFA)		192,900	198,000	203,100	208,200	213,900	219,300	225,000	231,000	237,000	243,000
DEPENSE-TOTAL		3,156,219	3,236,111	3,292,092	3,371,983	3,428,924	3,509,295	3,586,236	3,671,477	3,728,898	3,810,230
e. REVENU											
NOMBRE DE MENAGES		643	660	677	694	713	731	750	770	790	810
TARIF DE L'EAU FCFA500/MENAGE/MOIS		3,858,000	3,960,000	4,062,000	4,164,000	4,278,000	4,386,000	4,500,000	4,620,000	4,740,000	4,860,000
f. BILAN (FCFA)		+701,781	+723,889	+769,908	+792,017	+849,076	+876,705	+933,764	+948,523	+1,011,102	+1,049,770

## 4. MA'AN

A N N E E	1	2	3	4	5	6	7	8	9	10
a. POPULATION DESERVIE	2,000	2,030	2,060	2,090	2,120	2,150	2,180	2,210	2,250	2,290
b. DEBIT MOYENNE (m <sup>3</sup> /jour)	50	51	52	52	53	54	55	55	56	57
c. HEURES DE POMPAGE (Hr/jour)	5	5	5	5	5	5	6	6	6	6
d. DEPENCE										
1) CARBURANT ELECTRICITE (FCFA)	1,160,700	1,183,914	1,207,128	1,207,128	1,230,342	1,253,556	1,276,770	1,276,770	1,299,984	1,323,198
2) CONSOMMABLE (FCFA)	34,821	35,517	36,214	36,214	36,910	37,607	38,303	38,303	39,000	39,696
3) SALAIRE DE L'OPERATEUR (FCFA)	600,000	600,000	600,000	600,000	600,000	600,000	600,000	600,000	600,000	600,000
4) HONORAIRES DU REPARATEUR (FCFA)	51,480	52,200	52,920	53,820	54,540	55,260	55,980	56,880	57,780	58,860
	(72,072)	(73,080)	(74,088)	(75,348)	(76,356)	(77,364)	(78,372)	(79,632)	(80,892)	(82,404)
5) FRAISE ADMINISTRATIF (FCFA)	85,800	87,000	88,200	89,700	90,900	92,100	93,300	94,800	96,300	98,100
	(120,120)	(121,800)	(123,480)	(125,580)	(127,260)	(128,940)	(130,620)	(132,720)	(134,820)	(137,340)
DEPENSE-TOTAL	1,932,801	1,988,631	1,984,462	1,986,862	2,012,692	2,038,523	2,064,353	2,066,753	2,093,064	2,119,854
e. REVENUE	(1,987,713)	(2,014,311)	(2,040,910)	(2,044,270)	(2,070,868)	(2,097,467)	(2,124,065)	(2,127,425)	(2,154,696)	(2,182,638)
NOMBRE DE MENAGES	286	290	294	299	303	307	311	316	321	327
TARIF DE L'EAU										
FCFA500/MENAGE/MOIS	1,716,000	1,740,000	1,764,000	1,794,000	1,818,000	1,842,000	1,866,000	1,896,000	1,926,000	1,962,000
(FCFA700/MENAGE/MOIS)	(2,402,400)	(2,436,000)	(2,469,600)	(2,511,600)	(2,545,200)	(2,578,800)	(2,612,400)	(2,654,400)	(2,696,400)	(2,746,800)
f. BILAN (FCFA)										
FCFA500	-216,801	-218,631	-220,462	-192,862	-194,692	-196,523	-198,353	-170,753	-167,064	-157,854
FCFA700	+414,687	+421,689	+428,690	+467,330	+474,332	+481,333	+488,335	+526,975	+541,704	+564,162

5. AKOM II

A N N E E	1	2	3	4	5	6	7	8	9	10
a. POPULATION DESSERVIE	5,300	5,440	5,590	5,740	5,890	6,050	6,210	6,380	6,550	6,730
b. DEBIT MOYENNE (m <sup>3</sup> /jour)	133	136	140	144	147	151	155	160	164	168
c. HEURES DE POMPAGE (Hr/jour)	15	15	16	16	16	17	17	18	18	19
d. DEPENSE	0	0	0	0	0	0	0	0	0	0
1) CARBURANT ELECTRICITE (FCFA)	0	0	0	0	0	0	0	0	0	0
2) CONSOMMABLE (FCFA)	0	0	0	0	0	0	0	0	0	0
3) SALAIRE DE L'OPERATEUR (FCFA)	600,000	600,000	600,000	600,000	600,000	600,000	600,000	600,000	600,000	600,000
4) HONORAIRES DU REPARATEUR (FCFA)	136,260	139,860	143,820	147,600	151,380	155,520	159,660	163,980	168,480	172,980
5) FRAISE ADMINISTRATIF (FCFA)	227,100	233,100	239,700	246,000	252,300	259,200	266,100	273,300	280,800	288,300
DEPENSE-TOTAL	963,360	972,960	983,520	993,600	1,003,680	1,014,720	1,025,760	1,037,280	1,049,280	1,061,280
e. REVENUE	757	777	799	820	841	864	887	911	936	961
NOMBRE DE MENAGES	4,542,000	4,662,000	4,794,000	4,920,000	5,046,000	5,184,000	5,322,000	5,466,000	5,616,000	5,766,000
TARIF DE L'EAU FCFA500/MENAGE/MOIS	+3,578,640	+3,689,040	+3,810,480	+3,926,400	+4,042,320	+4,169,280	+4,296,240	+4,428,720	+4,566,720	+4,704,720
f. BILAN (FCFA)										

Par ce projet, les 3.800 habitants bénéficiaires d'Akom II sont directement approvisionnés par l'installation d'approvisionnement en eau par tuyau. 2 villages du site situés au bord ouest, Nlomoto et Nyabitande seront inclus dans le projet futur. Cependant, un bac de distribution sera installé au bout ouest du tuyau dans ces deux villages, on considère donc que la cotisation sera perçue par les habitants, et que le fond collecté sera utilisé pour le projet de tuyau futur en temps opportun.









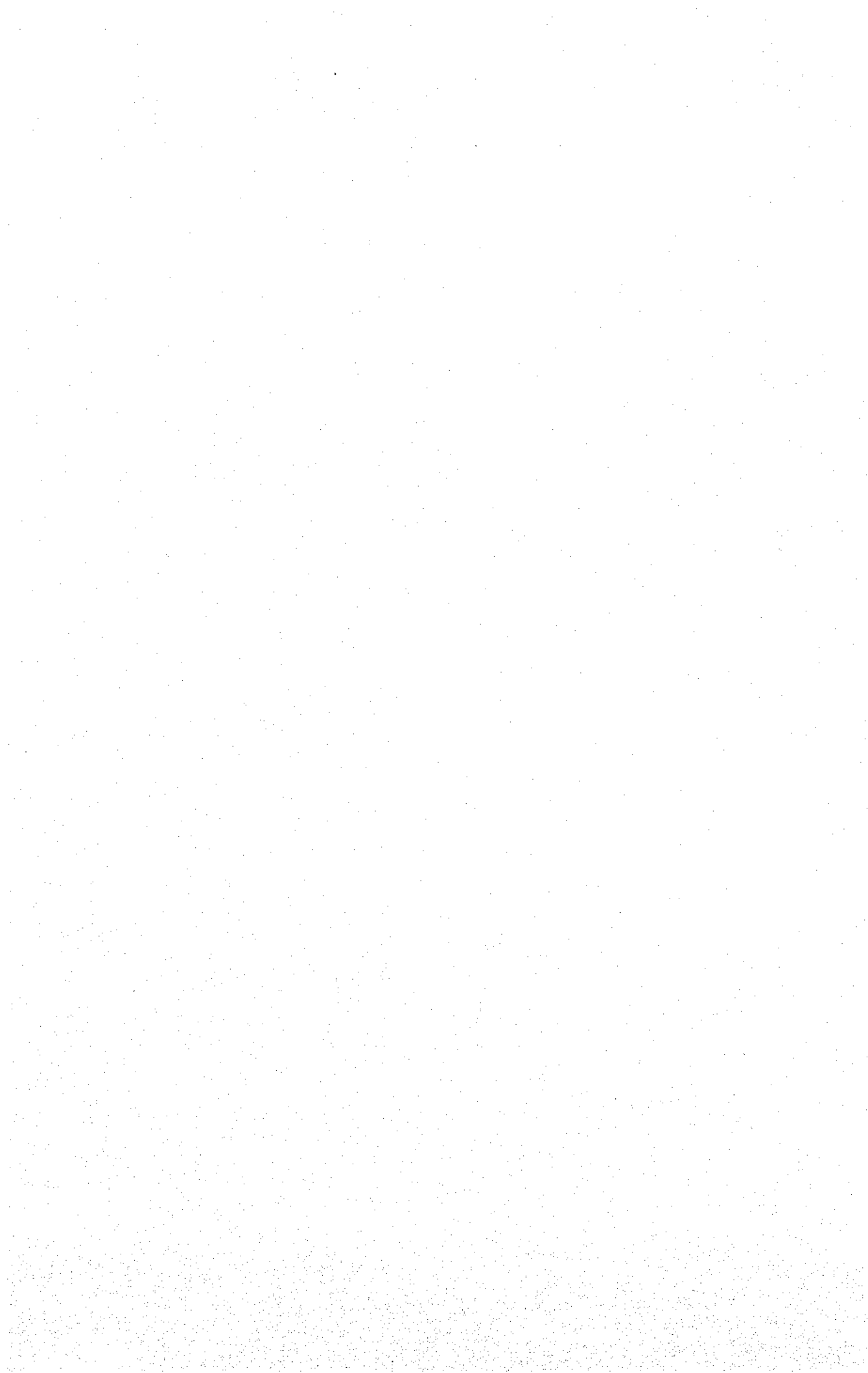

JICA