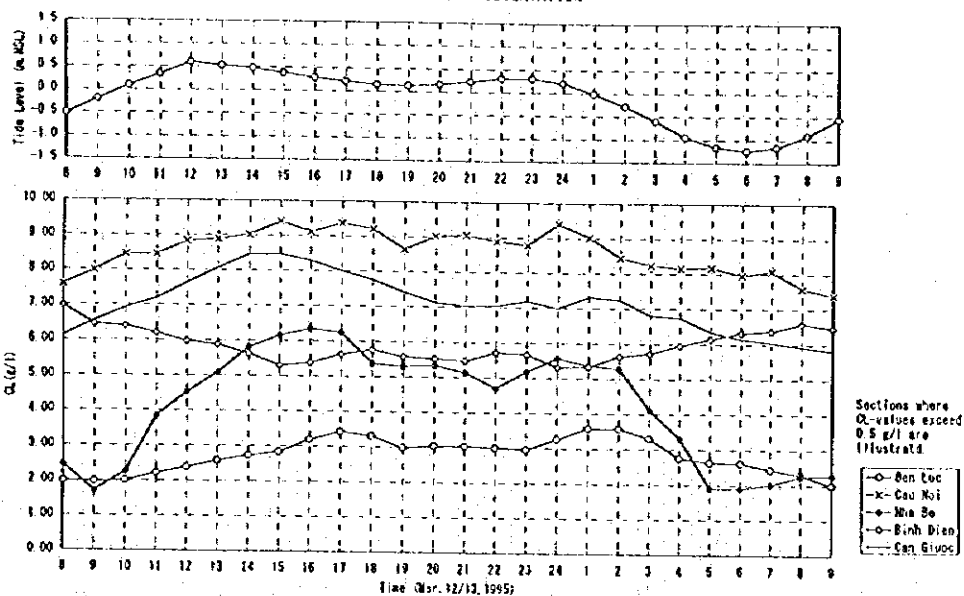


No	Name	Land mark	River	Code	Sampling (nos)						Remarks
					(1) Oct 26-Feb	(2) Oct 1-Mar	(3) Oct 2-3 Mar	(4) Oct 3-3 Mar	(5) Oct 1-13 Mar	(6) Oct 2-18 Mar	
1	Moc Hoa	Bridge	West Van Co R.	C-01	50	12			78	78	WL
2	Luyen Nhon		West Van Co R.	C-02	50	12			78	78	WL, S
3	Can An	Bridge	West Van Co R.	C-03	50	12			78	78	WL, S
4	Hiep Hoa		East Van Co R.	C-04	50	12	12		78	78	WL
5	Xuan Khanh		East Van Co R.	C-05	50	12	12		78	78	WL, S
6	Ben Luc	Bridge	East Van Co R.	C-06	50	12	12		78	78	WL, S
7	Can Hoi		Vam Co R.	C-07	50	12	12		78	78	WL, S
8	Thu Dau Mot		Saigon R.	C-08	50		12	12	78	78	WL, S
9	An Son		Saigon R.	C-09	50		12	12	78	78	S
10	Lai Thieu	Bridge	Saigon R.	C-10	50		12	12	78	78	WL, S
11	Hiep Binh	Bridge	Saigon R.	C-11	50		12	12	78	78	S
12	Thu An	Bridge	Saigon R.	C-12	50		12	12	78	78	WL, S
13	Hiep Hoa	Bridge	Dong Nai R.	C-13	50			12	78	78	WL
14	Long Binh	Bridge	Dong Nai R.	C-14	50			12	78	78	S
15	Thu Hoa		Dong Nai R.	C-15	50			12	78	78	(S)
16	Cat Lai		Dong Nai R.	C-16	50			12	78	78	WL, S
17	Nha Be		Dong Nai R.	C-17	50			12	78	78	WL, S
18	C. Naep	Bridge	Nang Canal	C-18	50		12		78	78	S
19	Binh Dien	Bridge	Ben Luc R.	C-19	50		12		78	78	WQ
20	Can Giuoc	Bridge	Rach Cac R.	C-20	50		12		78	78	WL, S
21	Nam Ong Tong		West Van Co R.	L1-01		12					
22	Ap Hoa Tho		West Van Co R.	L1-02		12					
23	Cho Ky Son		West Van Co R.	L1-03		12					
24	Nam Cao		West Van Co R.	L1-04		12					
25	Go Dau		East Van Co R.	L1-05		12					
26	Ap Loc Chanh		East Van Co R.	L1-06		12	12				
27	Duc Hoa		East Van Co R.	L1-07		12	12				
28	Ap Hoa Do		East Van Co R.	L1-08		12					
29	Nam Rach Hung		Vam Co R.	L1-09		12					
30	Ap Da Nho		Vam Co R.	L1-10		12	12	12			
31			Kinh Tay	L2-01		12					
32			Kinh Do Ho	L2-02		12					
33	Ap Binh Thuan (1)		Thu Thua	L2-03		12					
34	Ap Ninh Hung	Bridge	Kinh Thai My	L2-04		12					
35	Can Bong	Bridge	Kinh Rach Tra	L2-05		12					
36	Cau Naep	Bridge	Kinh Naep	L2-06		12					
37	Cau Chu Y	Bridge	Kinh Dai	L2-07		12					
38	Fao Quang		Rach Chi R.	L2-08		12					
39	Thu Hoa		Saigon R.	L3-01				12			
40	Tan Hinh		Dong Nai R.	L3-02				12			
41	Long Binh (2)		Dong Nai R.	L3-03				12			
42	Nam Van Voi		Dong Nai R.	L3-04				12			
43	Ap Dong Binh		Dong Nai R.	L3-05				12			
44	Nam Huong Chua	Bridge	Tac R.	L3-06				12			
45	Cau Rach Chiec	Bridge	Rach Chiec	L3-07				12			
46	Nam Huong Chua	Bridge	Rach Chiec	L3-08				12			
47	Long Truong	Bridge	Rach Ong Nheu	L3-09				12			

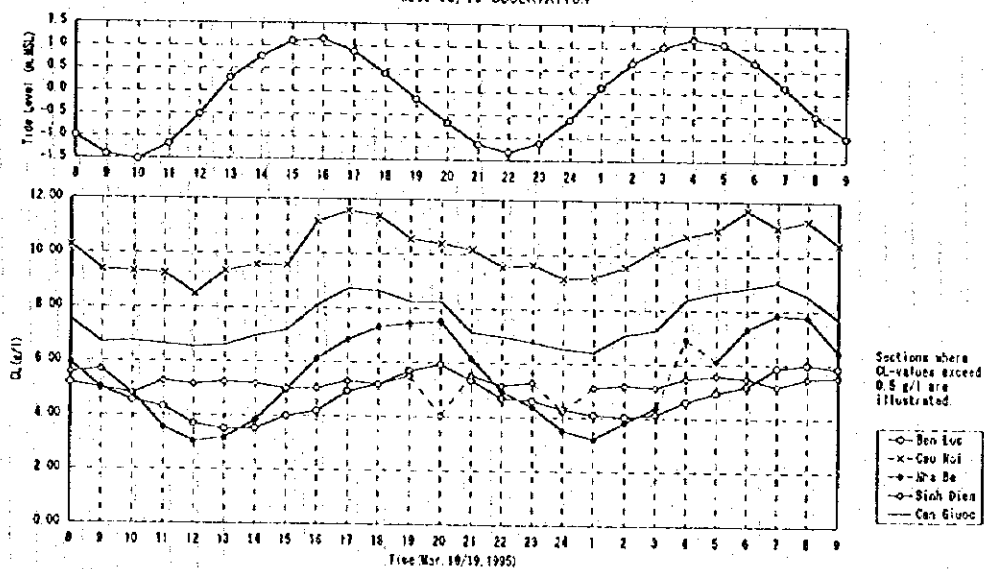
SOCIALIST REPUBLIC OF VIET NAM  
 MASTER PLAN STUDY ON DONG NAI RIVER  
 AND SURROUNDING BASINS  
 WATER RESOURCES DEVELOPMENT  
 JAPAN INTERNATIONAL COOPERATION AGENCY

**Figure 7.11**  
 Field Observation of Salinity Intrusion

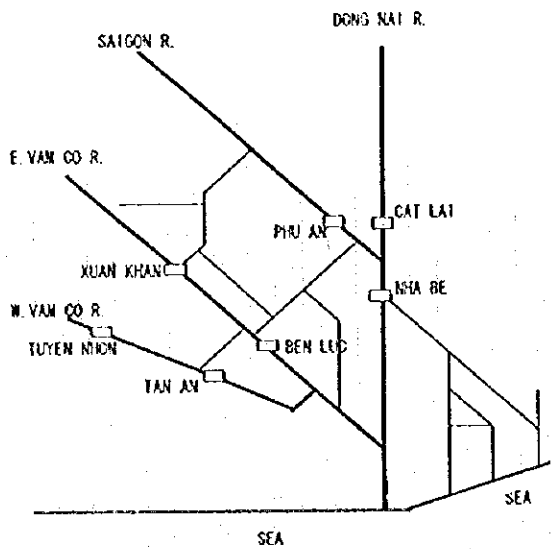
MAR-12/13 OBSERVATION



MAR-18/19 OBSERVATION

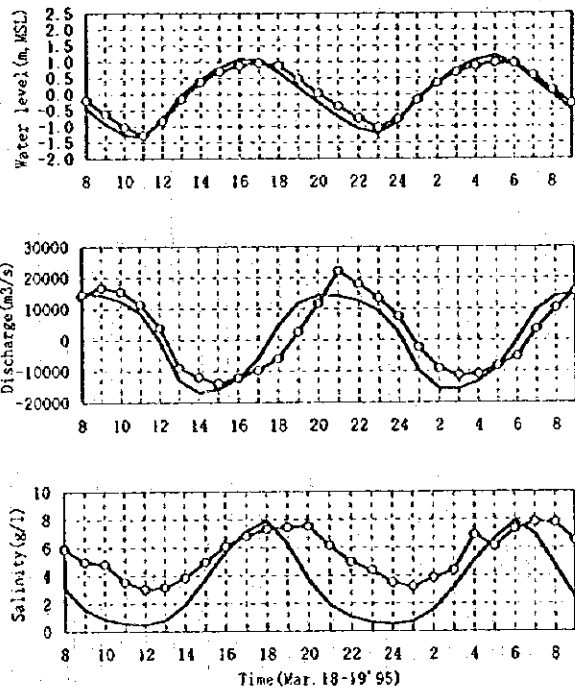


Consecutive Salinity Observation

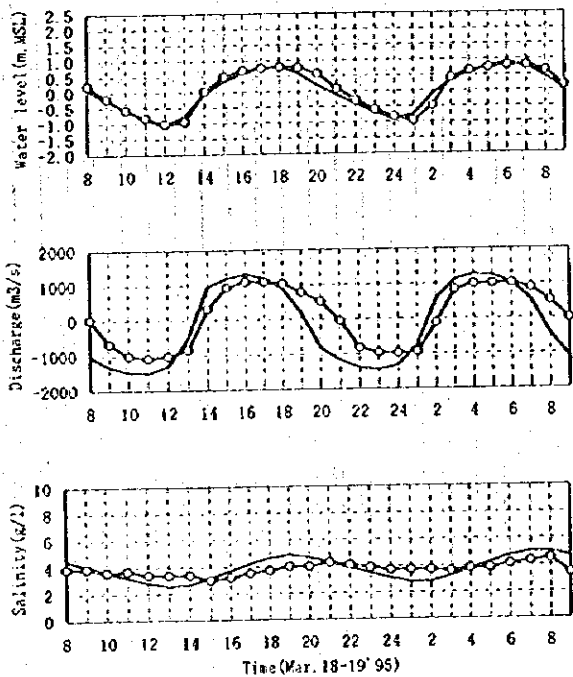


Channel System and Location of Observation Sections

NHA BE: C-17, SEC. NO. 106



TAN AN: C-03, SEC. NO. 30



BEN LUC: C-06, SEC. NO. 411

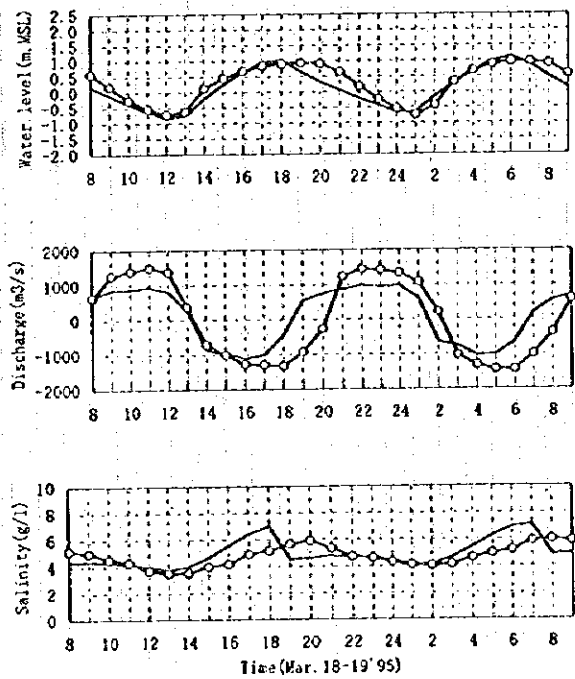
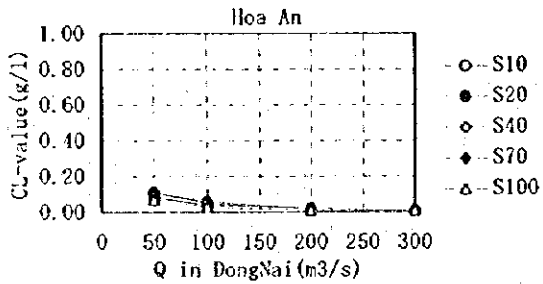


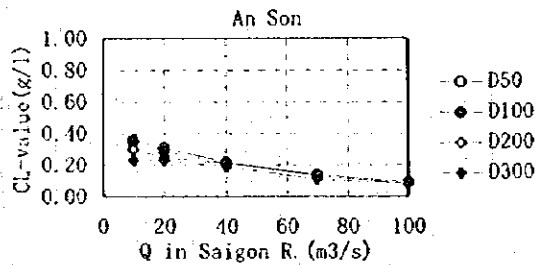
Figure 7.13  
 Calibration Result of Salinity  
 Intrusion Model

## Relationship between Salinity and Channel Discharge

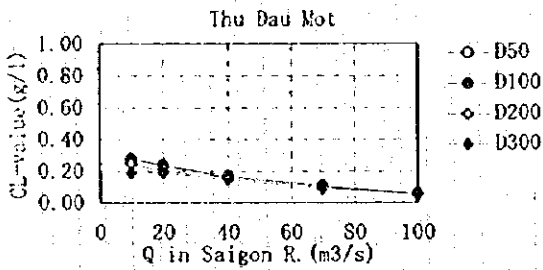
Calculated Results of Salinity for Various Discharge Combinations of Dong Nai and Saigon Rivers



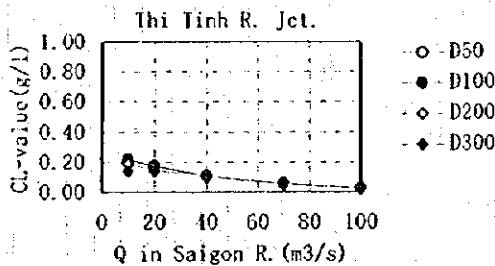
		Q in Dong Nai R. (m3/s)			
Case	Unit	50	100	200	300
S10	g/l	0.11	0.06	0.02	0.01
S20	g/l	0.11	0.05	0.02	0.01
S40	g/l	0.09	0.04	0.02	0.01
S70	g/l	0.08	0.04	0.02	0.01
S100	g/l	0.07	0.03	0.01	0.01



		Q in Saigon R. (m3/s)				
Case	Unit	10	20	40	70	100
D50	g/l	0.36	0.31	0.22	0.14	0.09
D100	g/l	0.35	0.29	0.21	0.14	0.09
D200	g/l	0.30	0.25	0.21	0.13	0.08
D300	g/l	0.23	0.23	0.19	0.11	0.08



		Q in Saigon R. (m3/s)				
Case	Unit	10	20	40	70	100
D50	g/l	0.28	0.24	0.17	0.11	0.06
D100	g/l	0.28	0.23	0.16	0.10	0.06
D200	g/l	0.25	0.20	0.16	0.10	0.05
D300	g/l	0.19	0.19	0.15	0.09	0.05

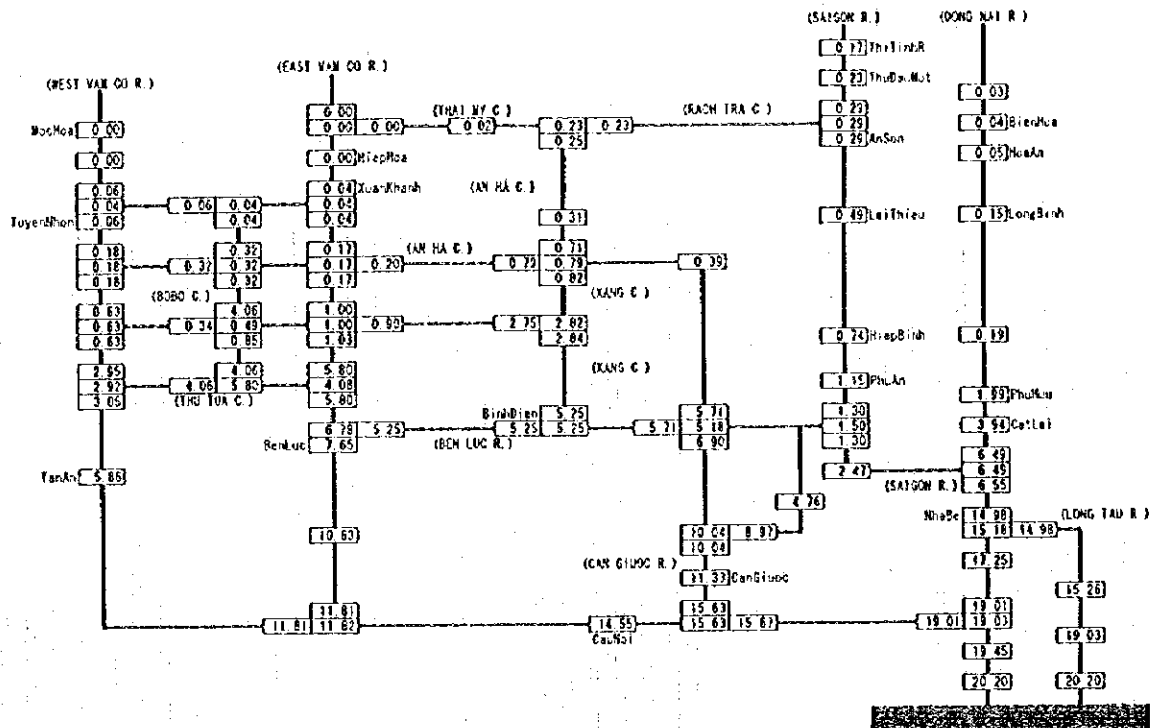


		Q in Saigon R. (m3/s)				
Case	Unit	10	20	40	70	100
D50	g/l	0.22	0.18	0.11	0.06	0.03
D100	g/l	0.21	0.17	0.11	0.06	0.03
D200	g/l	0.19	0.15	0.11	0.06	0.03
D300	g/l	0.14	0.14	0.1	0.05	0.02

NOTE: 1) D50, D100, D200 and D300 denote cases of Dong Nai river discharges of 50, 100, 200 and 300 m<sup>3</sup>/s, respectively.  
 2) S10, S20, S40, S70 and S100 denote cases of Saigon river discharges of 10, 20, 40, 70 and 100 m<sup>3</sup>/s, respectively.

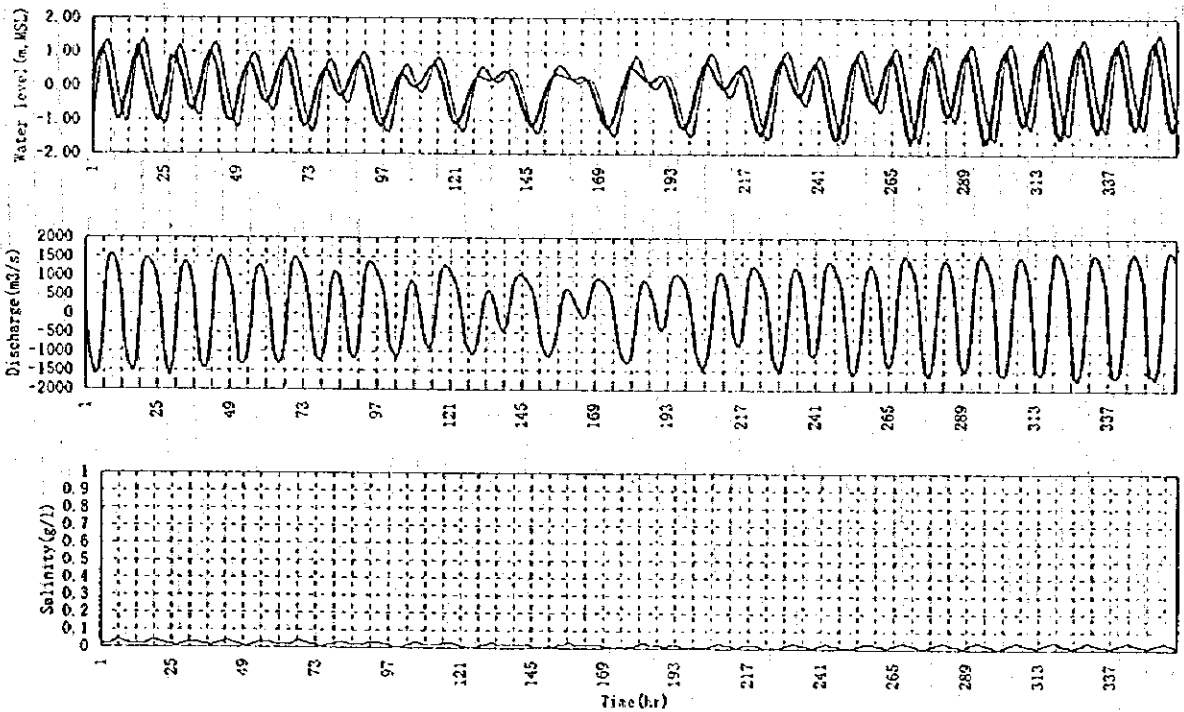
**Figure 7.14**  
 Discharge and Salinity at Hoa An  
 and Thu Dau Mot

DISTRIBUTION OF MAX. SALINITY DURING 15 DAYS (D100S25)



Result of Salinity Intrusion Analysis (D100S25)

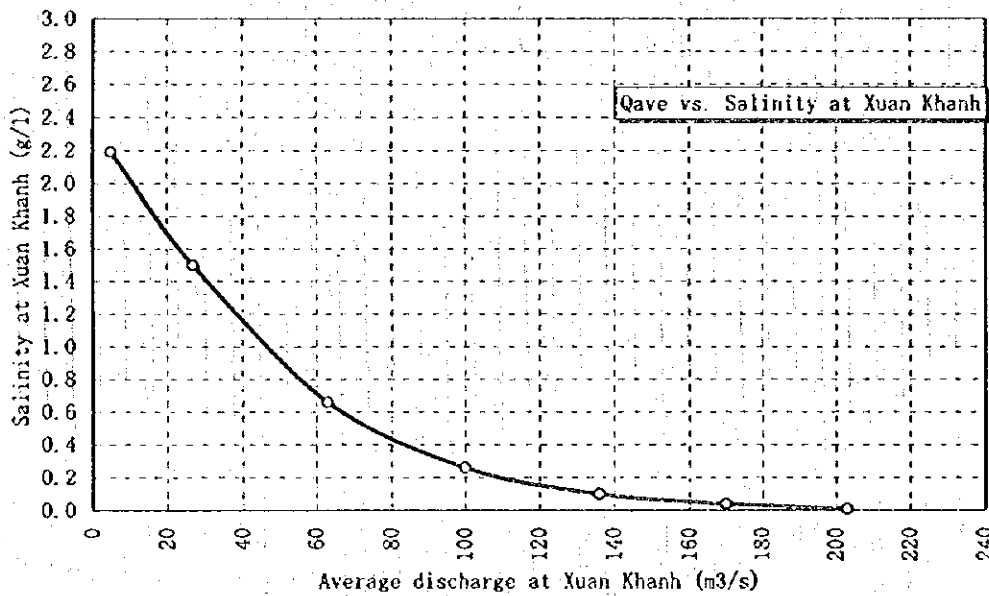
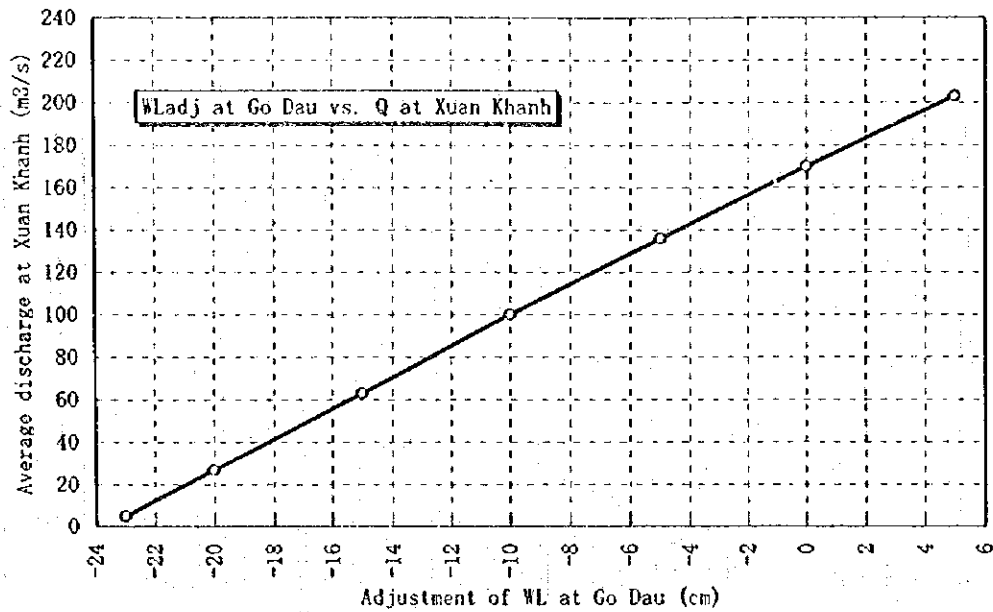
SECTION: HOA AN (74)



SOCIALIST REPUBLIC OF VIET NAM  
 MASTER PLAN STUDY ON DONG NAI RIVER  
 AND SURROUNDING BASINS  
 WATER RESOURCES DEVELOPMENT  
 JAPAN INTERNATIONAL COOPERATION AGENCY

Figure 7.15  
 Variation of Salinity during 15 Days

### Salinity and Discharge at Xuan Khanh

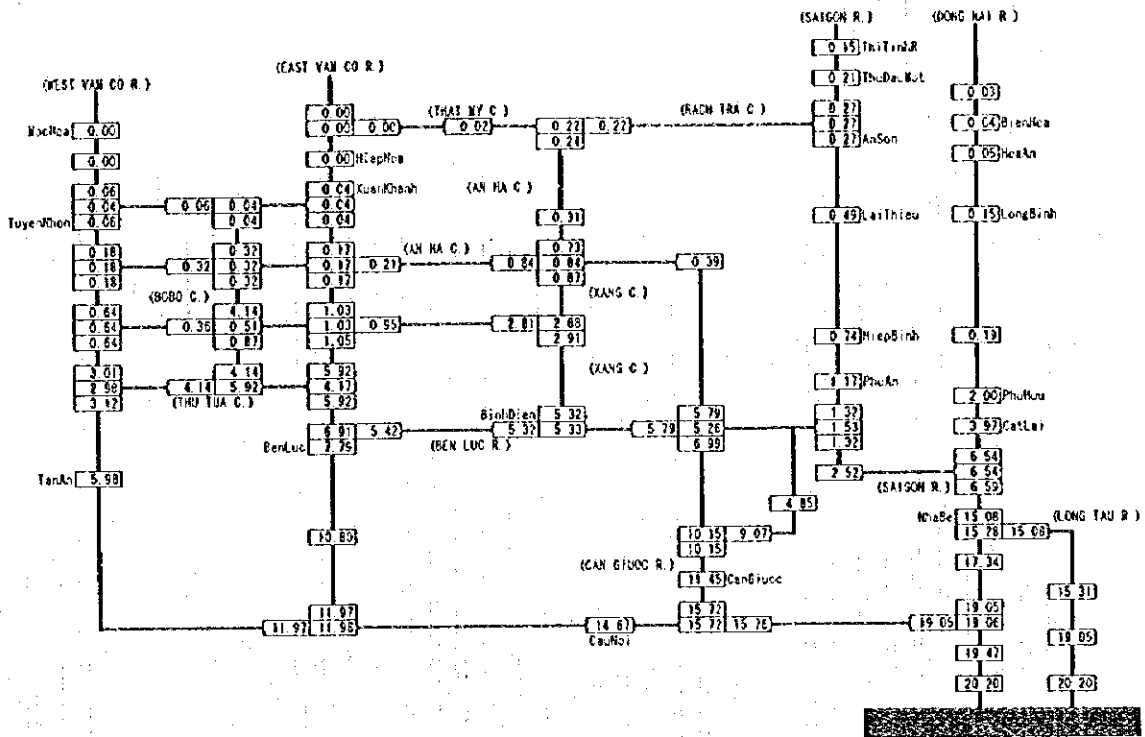


WLadj at Go Dau (dl:cm)	5	0	-5	-10	-15	-20	-23
Qave at Xuan Khanh (m3/s)	203	170	136	100	63	27	5
Clmax at Xuan Khanh (g/l)	0.01	0.01	0.10	0.26	0.66	1.50	2.19

SOCIALIST REPUBLIC OF VIET NAM  
 MASTER PLAN STUDY ON DONG NAI RIVER  
 AND SURROUNDING BASINS  
 WATER RESOURCES DEVELOPMENT  
 JAPAN INTERNATIONAL COOPERATION AGENCY

Figure 7.16  
 Salinity for Various Discharges  
 at Xuan Khanh

DISTRIBUTION OF MAX. SALINITY DURING 15 DAYS (Channel Improvement Case-0: Existing)



DISTRIBUTION OF MAX. SALINITY DURING 15 DAYS (Channel Improvement Case-2)

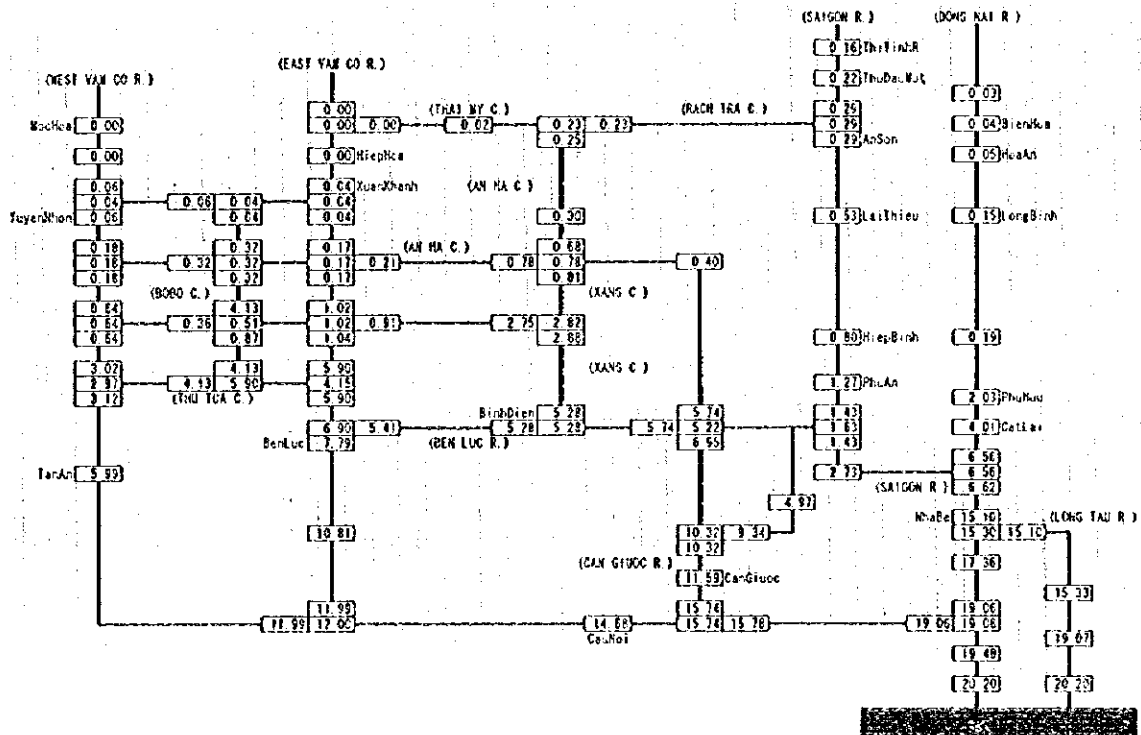
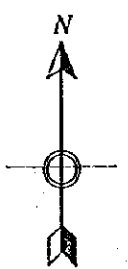
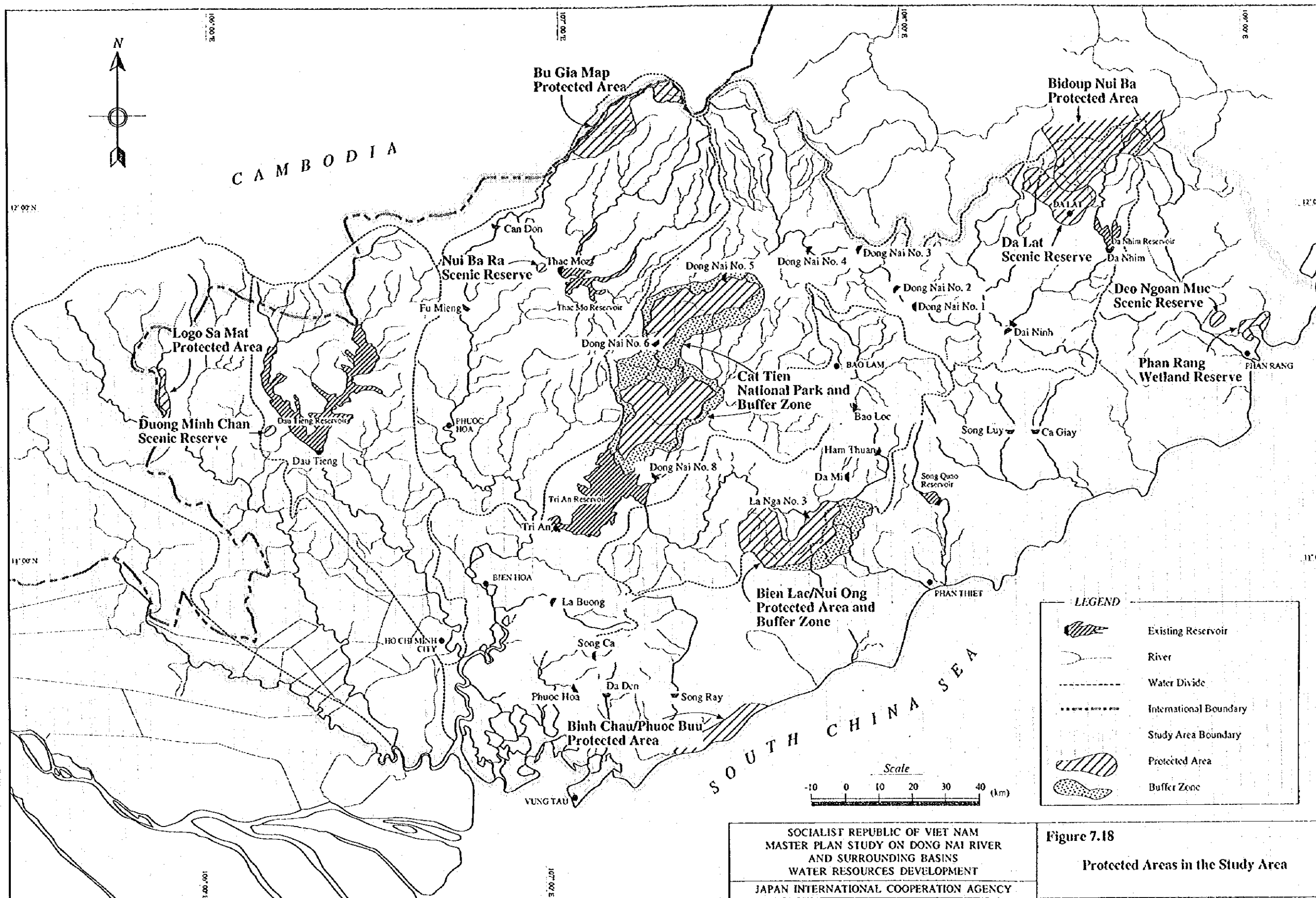


Figure 7.17  
 Distribution of Maximum Salinity  
 and Channel Improvement



CAMBODIA

Bu Gia Map Protected Area

Bidoup Nui Ba Protected Area

Nui Ba Ra Scenic Reserve

Da Lat Scenic Reserve

Logo Sa Mat Protected Area

Duong Minh Chan Scenic Reserve

Cat Tien National Park and Buffer Zone

Deo Ngoan Muc Scenic Reserve

Phan Rang Wetland Reserve

Bien Lac/Nui Ong Protected Area and Buffer Zone

Binh Chau/Phuoc Bui Protected Area

SOUTH CHINA SEA

PHUOC HOA

BIEN HOA

HO CHI MINH CITY

VUNG TAU

PHAN THIET

Da Mi

Ham Thuan

Bao Loc

BAO LAM

Song Luy

Ca Giay

Song Quao Reservoir

La Nga No. 3

Dong Nai No. 8

Tri An Reservoir

Tri An

La Buong

Song Ca

Phuoc Hoa

Da Den

Song Ray

Fu Mieng

Thac Mo Reservoir

Thac Mo

Can Don

Dong Nai No. 5

Dong Nai No. 4

Dong Nai No. 3

Dong Nai No. 2

Dong Nai No. 1

Dai Ninh

Da Nhim Reservoir

Da Nhim

PHAN RANG

12° 00' N

107° 00' E

11° 00' N

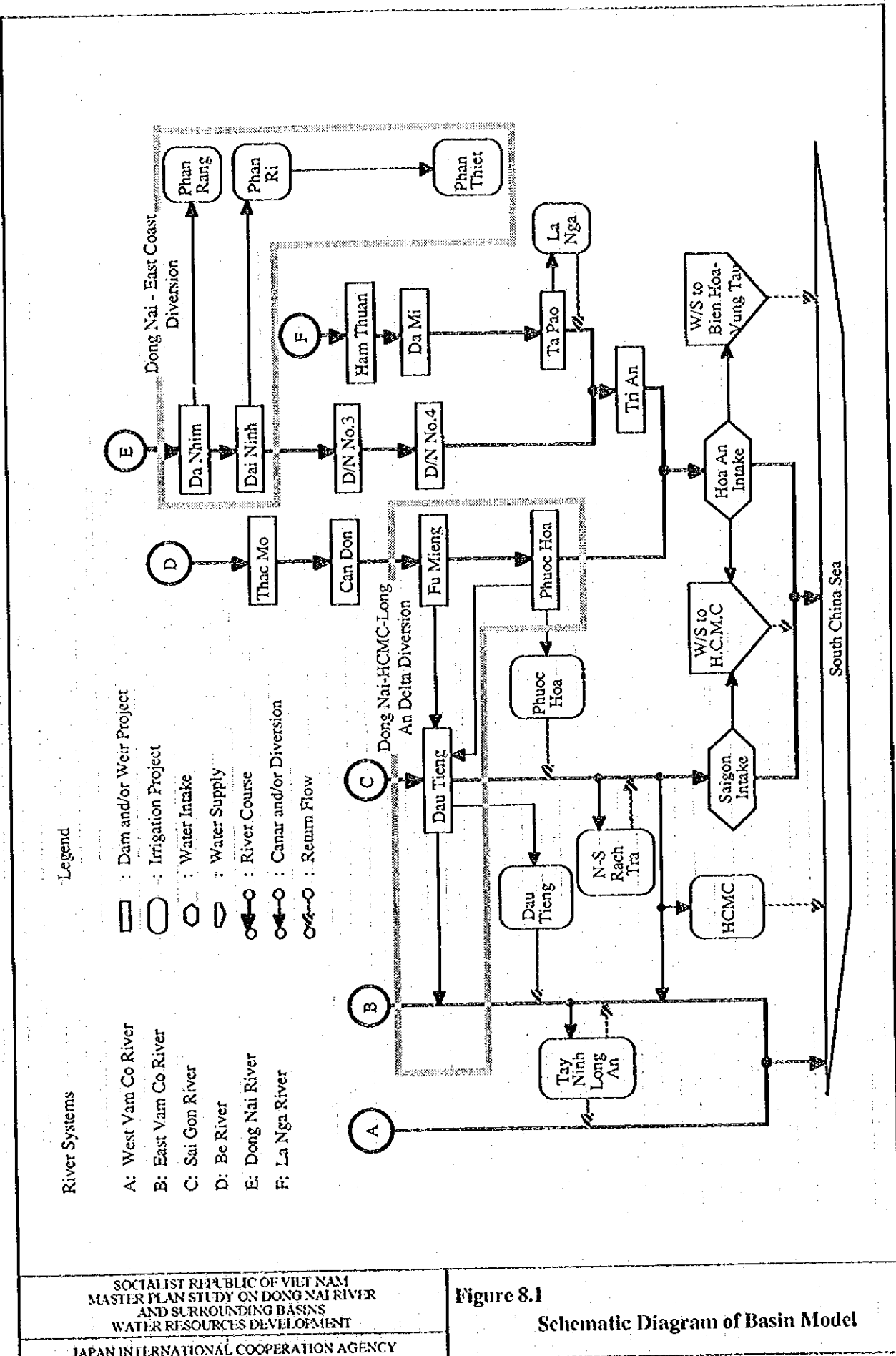
107° 00' E

107° 00' E

107° 00' E







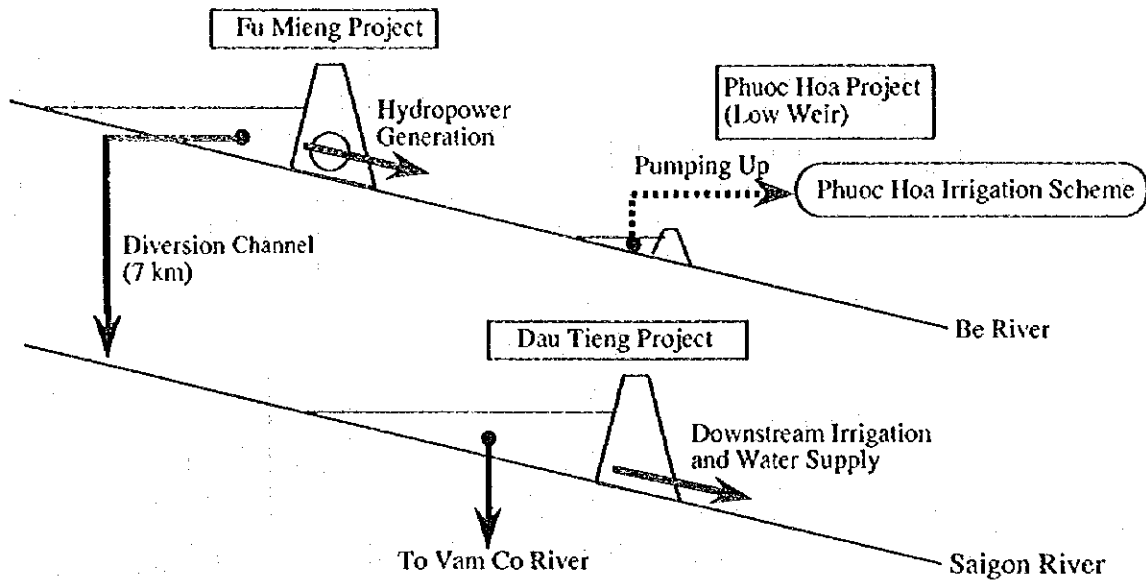
SOCIALIST REPUBLIC OF VIET NAM  
 MASTER PLAN STUDY ON DONG NAI RIVER  
 AND SURROUNDING BASINS  
 WATER RESOURCES DEVELOPMENT

JAPAN INTERNATIONAL COOPERATION AGENCY

Figure 8.1

Schematic Diagram of Basin Model

A. Fu Mieng Project with Diversion Channel, and Phuoc Hoa Project with Low Intake Weir and Pumping Facility



B. Fu Mieng Project and Phuoc Hoa Project with High Intake Weir with Diversion Channel

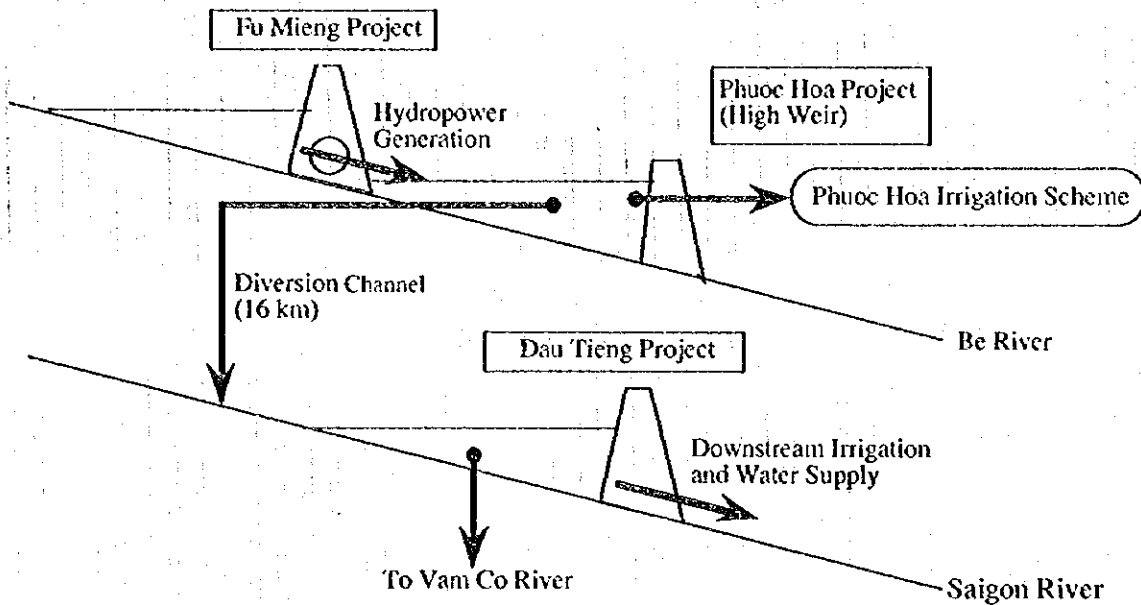
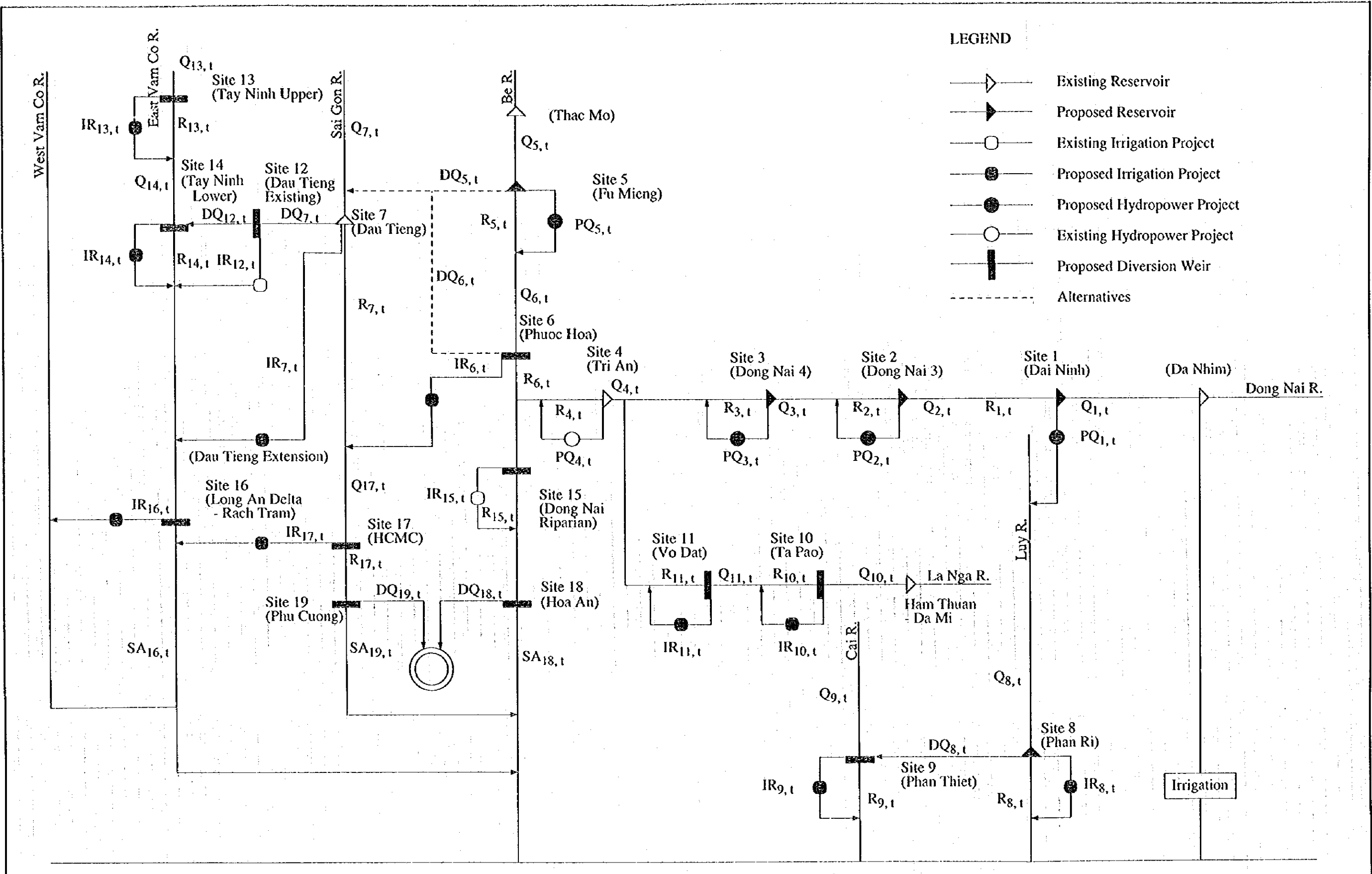


Figure 8.2

Diversion Alternatives from the Be River to the HCMC - Long An Delta





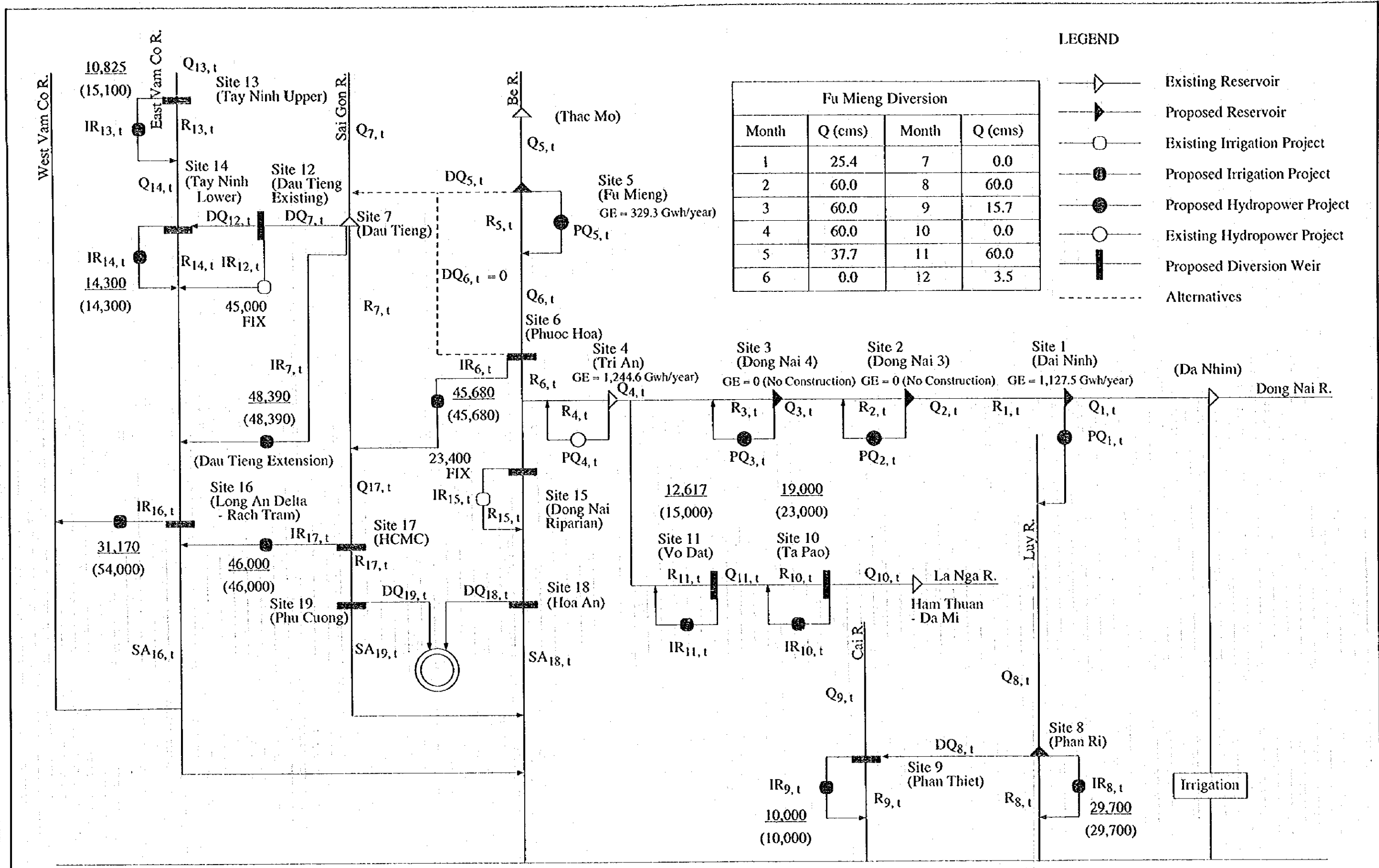
LEGEND

- ▷— Existing Reservoir
- ▷— Proposed Reservoir
- Existing Irrigation Project
- Proposed Irrigation Project
- Proposed Hydropower Project
- Existing Hydropower Project
- Proposed Diversion Weir
- - - Alternatives

SOUTH CHINA SEA

SOCIALIST REPUBLIC OF VIET NAM  
 MASTER PLAN STUDY ON DONG NAI RIVER  
 AND SURROUNDING BASINS  
 WATER RESOURCES DEVELOPMENT  
 JAPAN INTERNATIONAL COOPERATION AGENCY

Figure 8.3  
 System Diagram of the Study Area



Month	Q (cms)	Month	Q (cms)
1	25.4	7	0.0
2	60.0	8	60.0
3	60.0	9	15.7
4	60.0	10	0.0
5	37.7	11	60.0
6	0.0	12	3.5

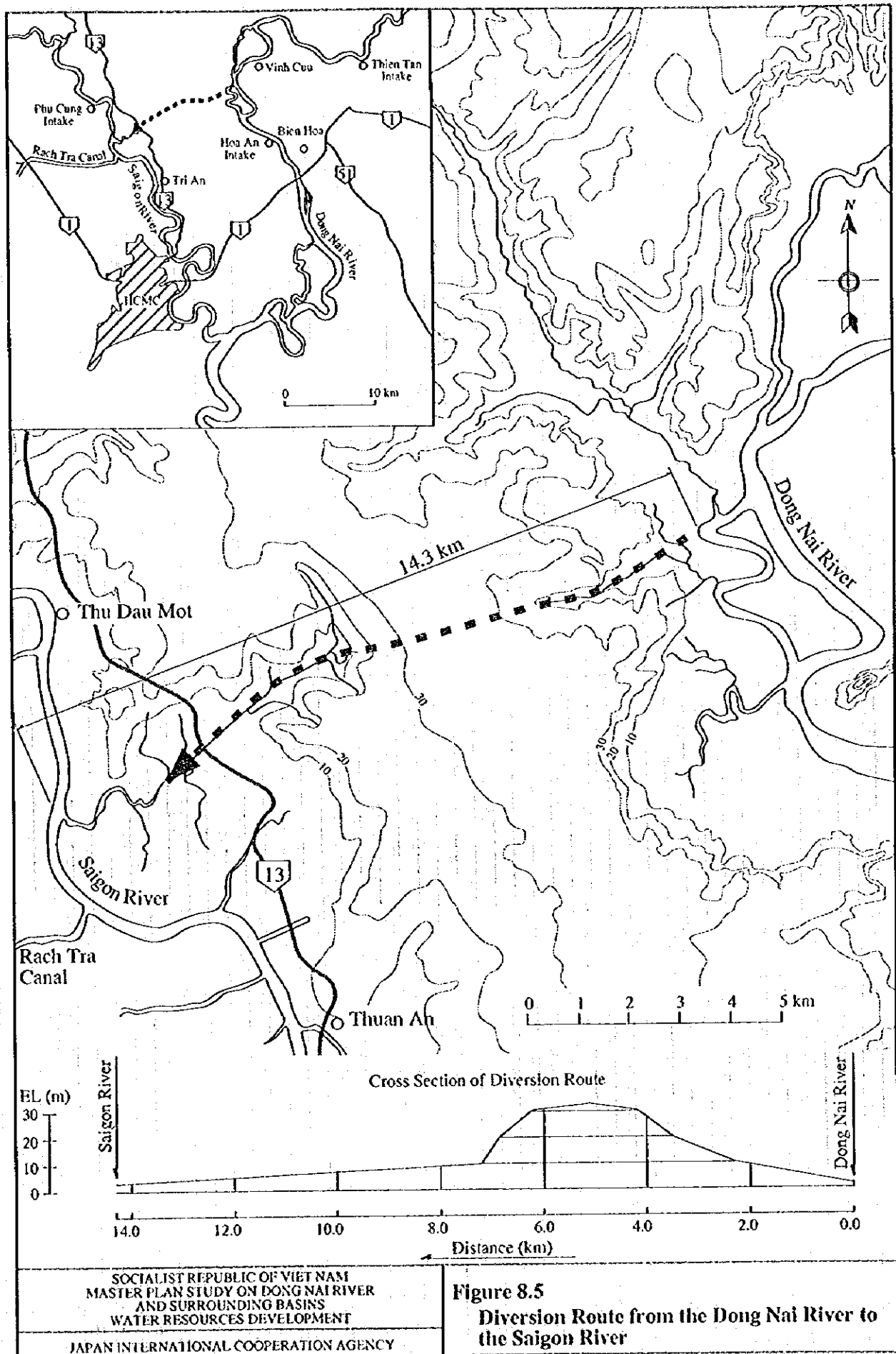
- LEGEND**
- Existing Reservoir
  - Proposed Reservoir
  - Existing Irrigation Project
  - Proposed Irrigation Project
  - Proposed Hydropower Project
  - Existing Hydropower Project
  - Proposed Diversion Weir
  - Alternatives

SOUTH CHINA SEA

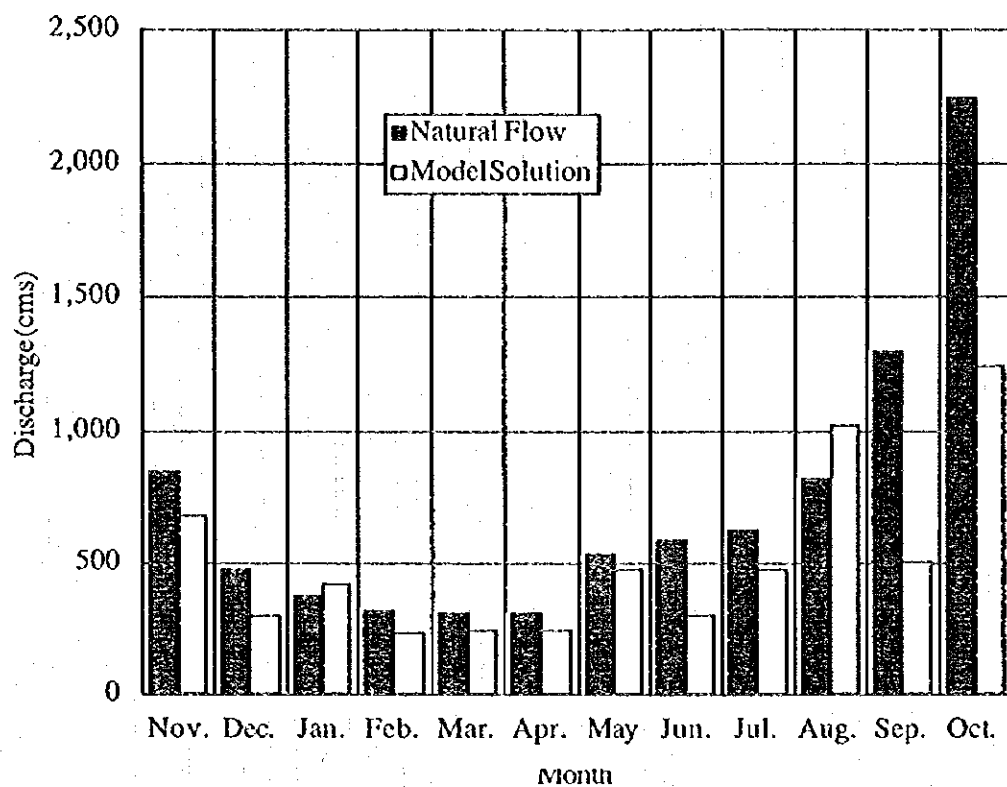
SOCIALIST REPUBLIC OF VIET NAM  
 MASTER PLAN STUDY ON DONG NAI RIVER  
 AND SURROUNDING BASINS  
 WATER RESOURCES DEVELOPMENT  
 JAPAN INTERNATIONAL COOPERATION AGENCY

**Figure 8.4**  
**Optimal Solution Obtained from the Model**







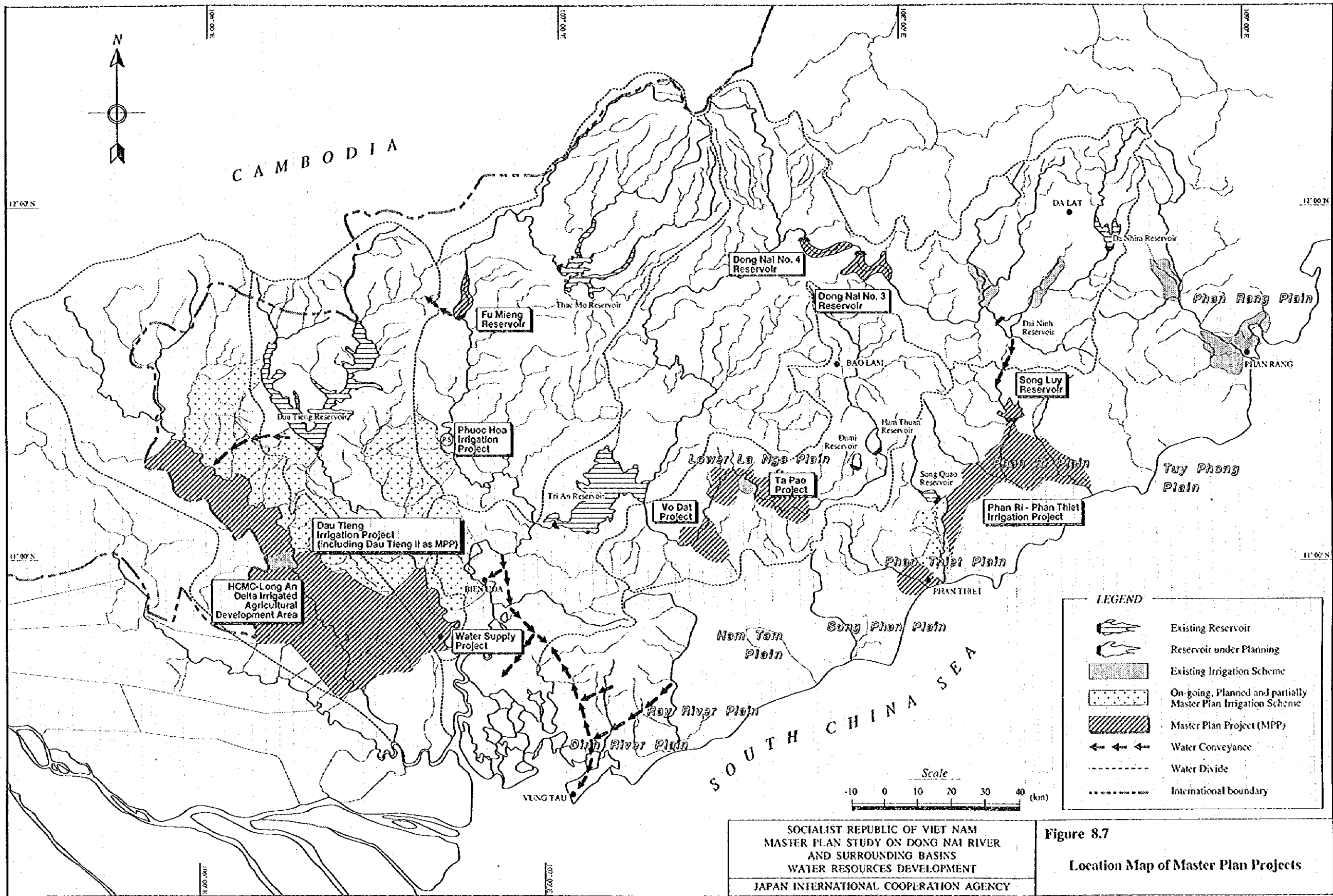


	Unit: m <sup>3</sup> /s	
	Natural	GAMS
Nov.	842.5	673.5
Dec.	466.6	295.1
Jan.	369.0	414.3
Feb.	315.9	233.5
Mar.	301.6	240.6
Apr.	300.8	243.4
May	526.4	468.1
Jun.	581.0	294.2
Jul.	616.5	471.5
Aug.	809.6	1,014.8
Sep.	1,289.4	500.1
Oct.	2,239.8	1,236.6

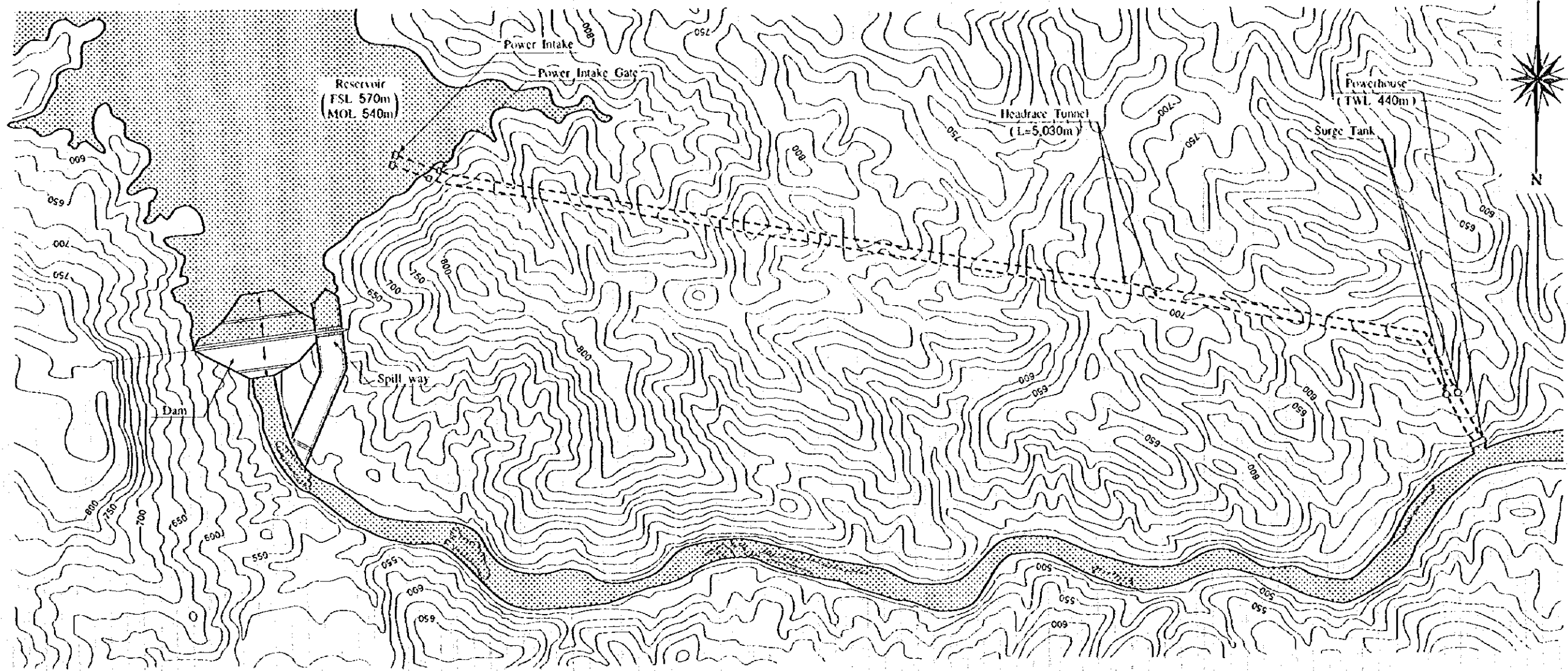
Figure 8.6

Discharge at Hoa An Pumping Station

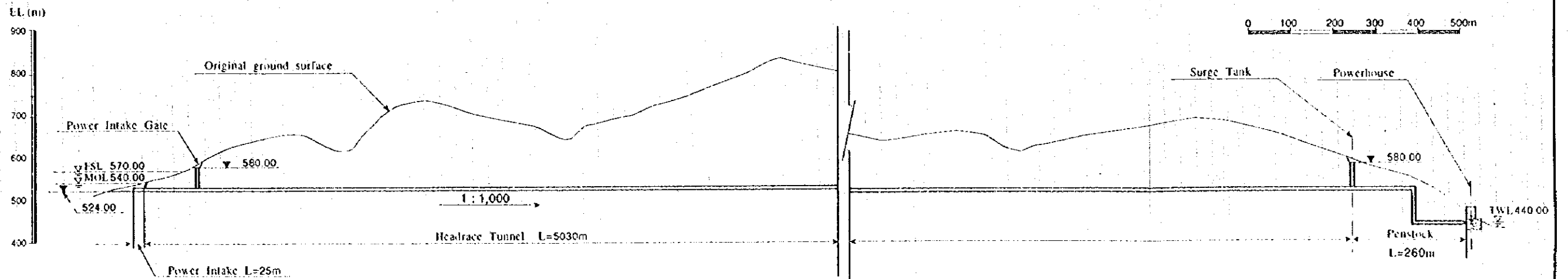




A : GENERAL PROJECT LAYOUT



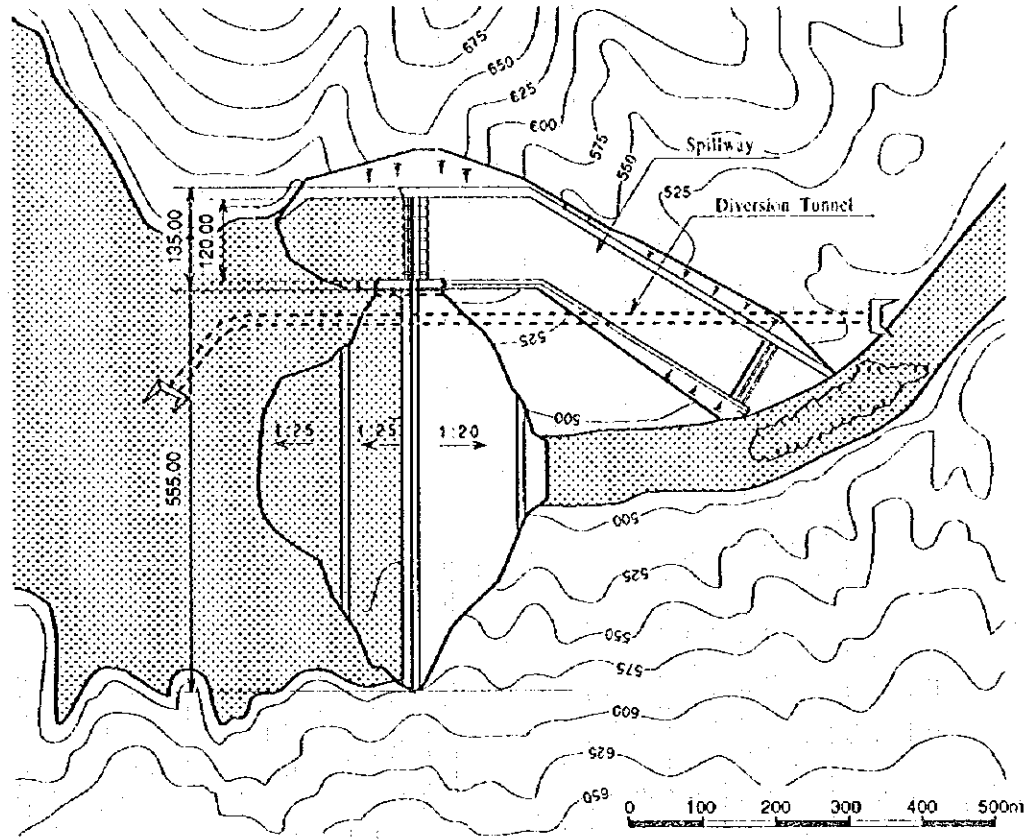
B : PROFILE OF WATERWAY



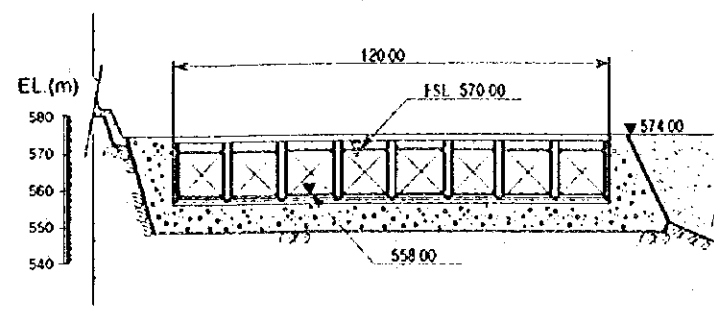
SOCIALIST REPUBLIC OF VIET NAM  
 MASTER PLAN STUDY ON DONG NAI RIVER  
 AND SURROUNDING BASINS  
 WATER RESOURCES DEVELOPMENT  
 JAPAN INTERNATIONAL COOPERATION AGENCY

Figure 9.1  
 Basic Layout Design of  
 Dong Nai No.3 Project (1/2)

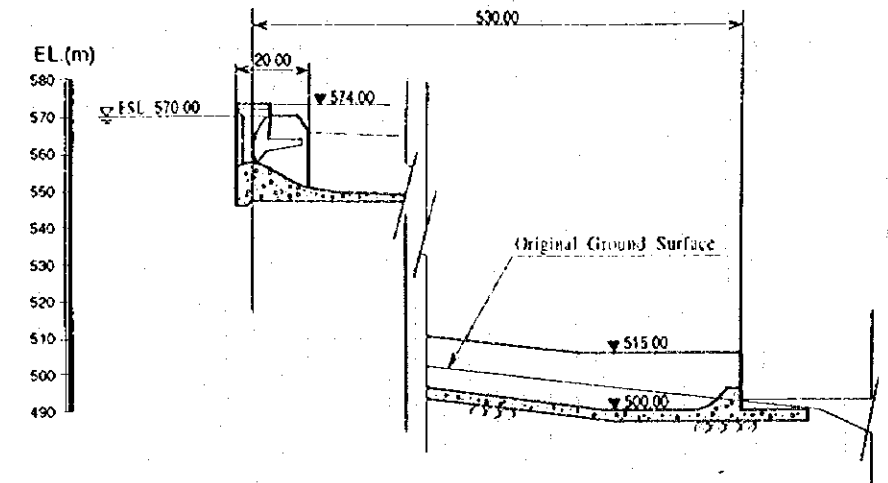
**C : PLAN OF DAM AND SPILLWAY**



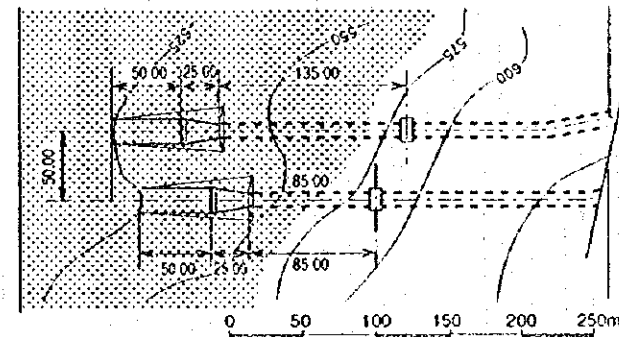
**F : UPSTREAM ELEVATION OF SPILLWAY**



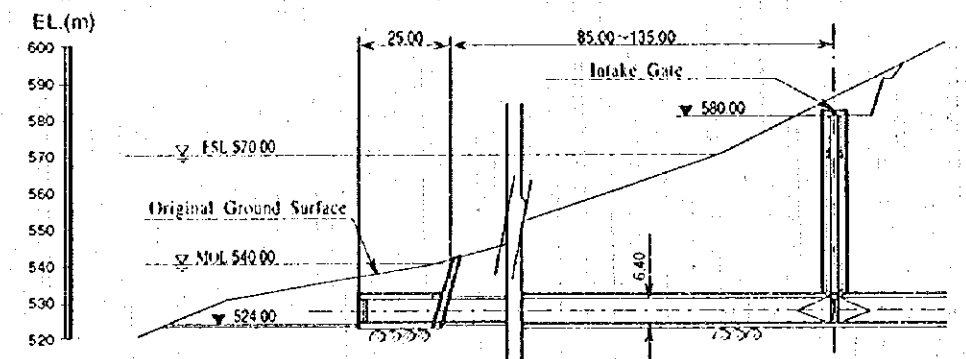
**G : PROFILE OF SPILLWAY**



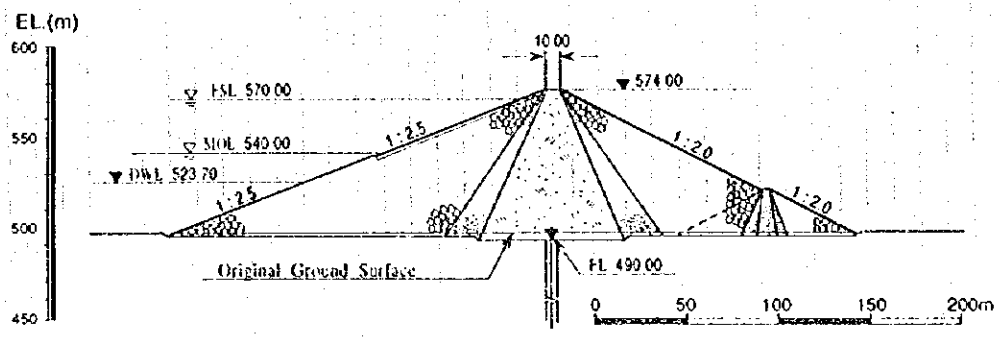
**H : PLAN OF POWER INTAKE**



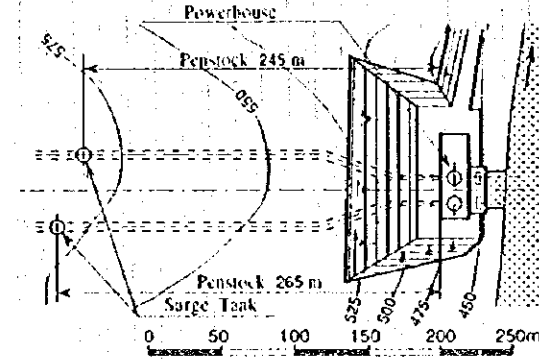
**I : PROFILE OF POWER INTAKE**



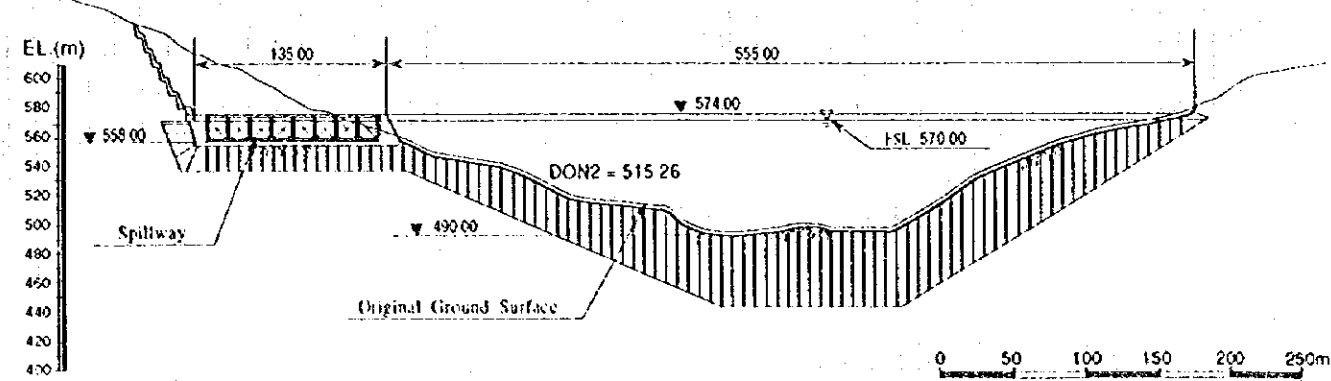
**D : TYPICAL SECTION OF DAM**



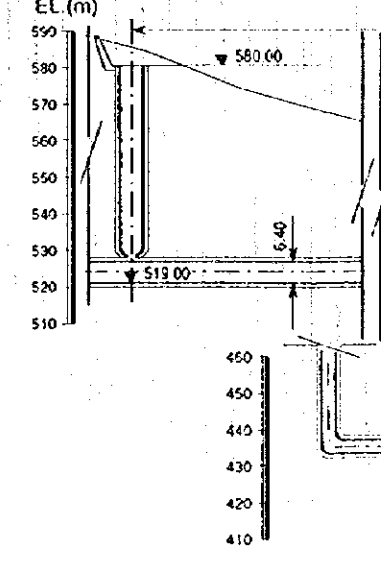
**J : PLAN OF PENSTOCK AND POWERHOUSE**



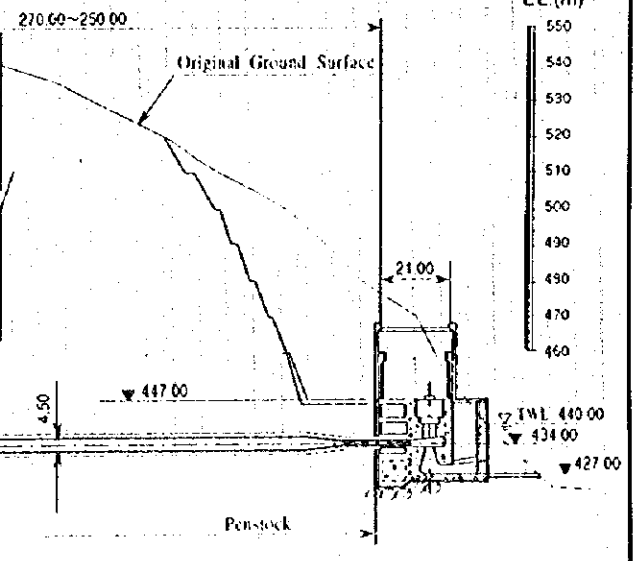
**E : UPSTREAM ELEVATION OF DAM**



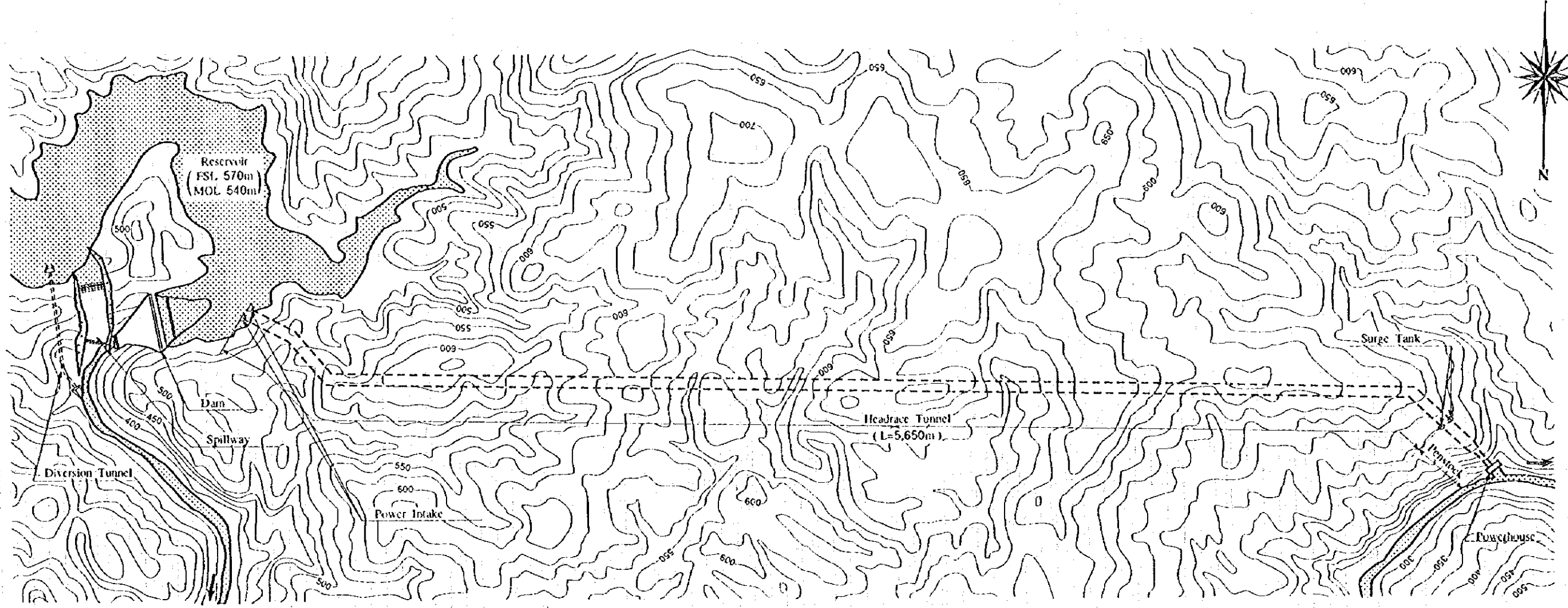
**K : PROFILE OF SURGE TANK**



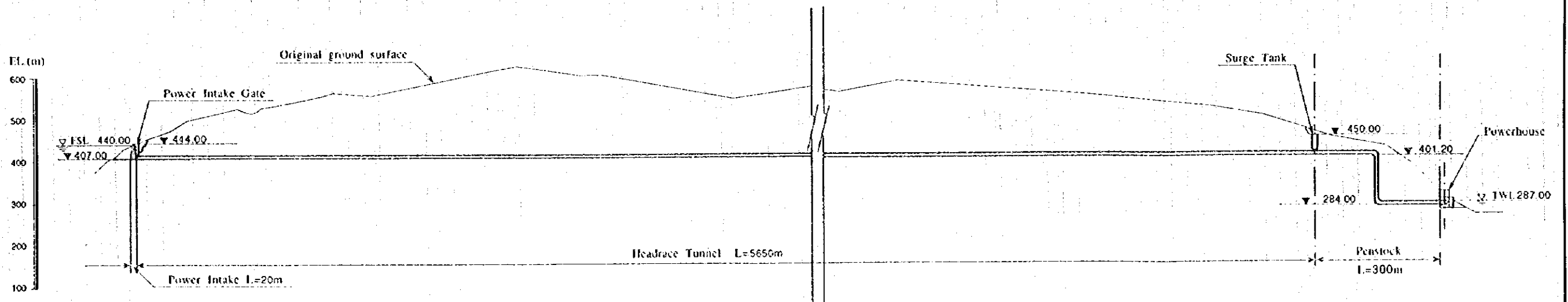
**L : PROFILE OF POWERHOUSE**



A : GENERAL PROJECT LAYOUT



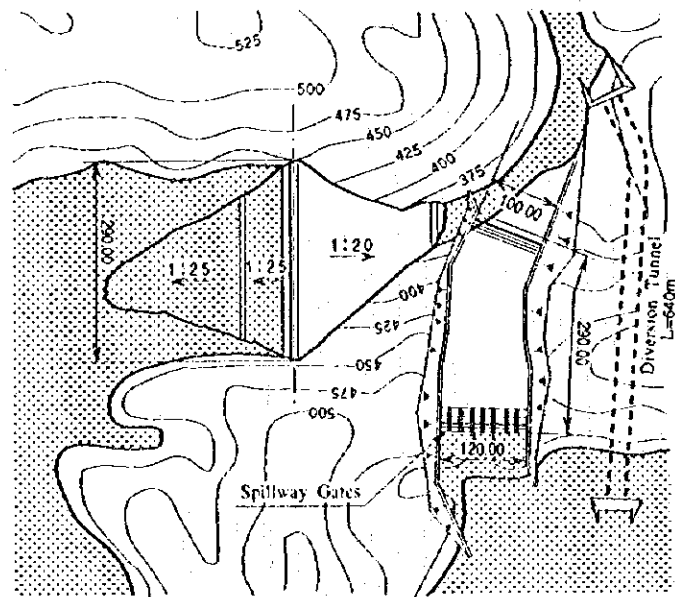
B : PROFILE OF WATERWAY



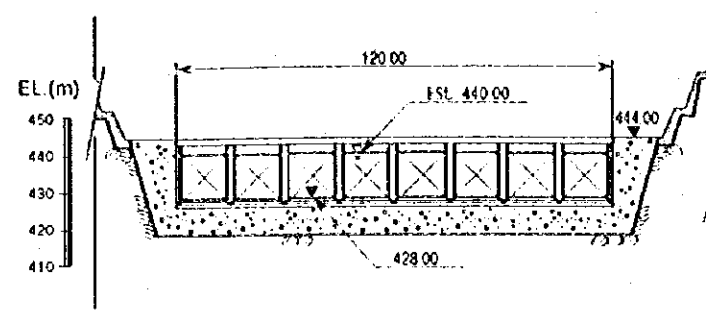
SOCIALIST REPUBLIC OF VIET NAM  
 MASTER PLAN STUDY ON DONG NAI RIVER  
 AND SURROUNDING BASINS  
 WATER RESOURCES DEVELOPMENT  
 JAPAN INTERNATIONAL COOPERATION AGENCY

Figure 9.2  
 Basic Layout Design of  
 Dong Nai No.4 Project (1/2)

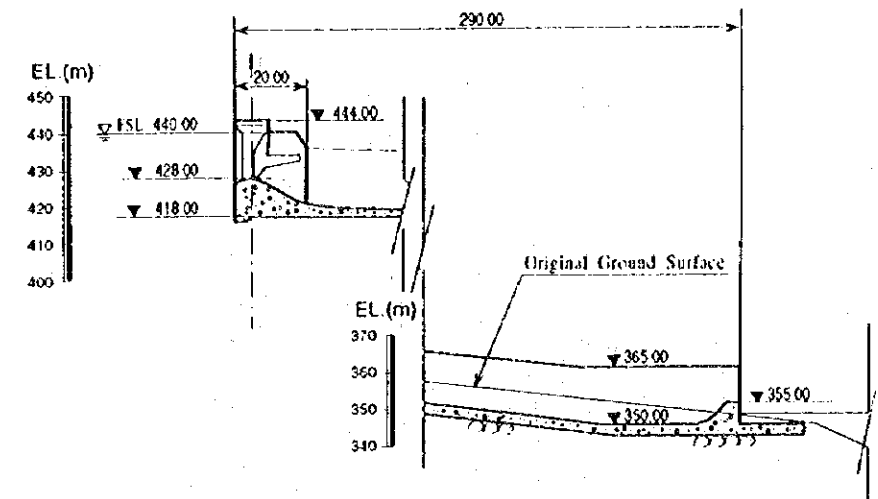
C : PLAN OF DAM AND SPILLWAY



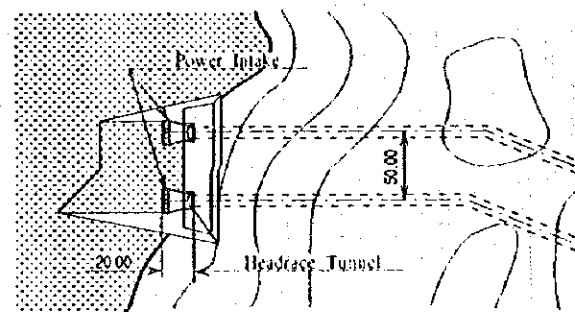
F : UPSTREAM ELEVATION OF SPILLWAY



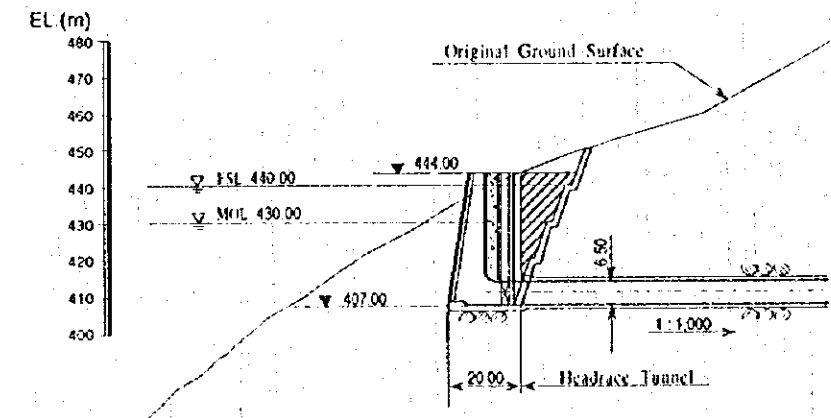
G : PROFILE OF SPILLWAY



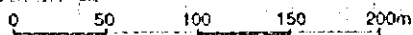
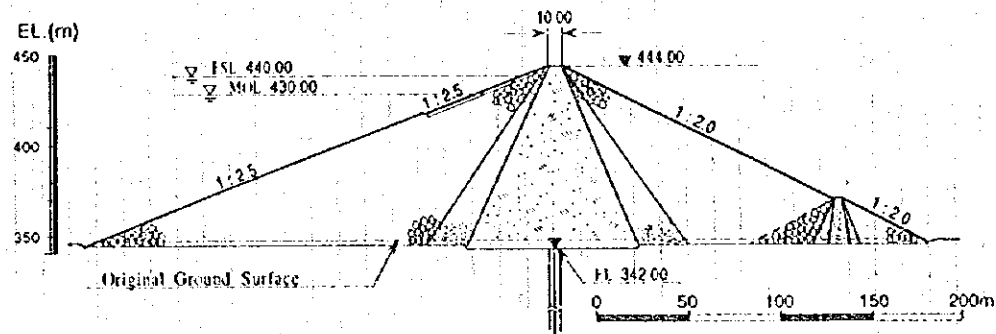
H : PLAN OF POWER INTAKE



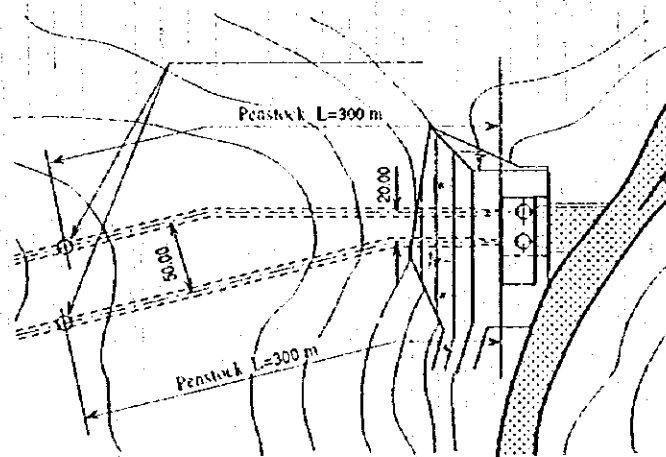
I : PROFILE OF POWER INTAKE



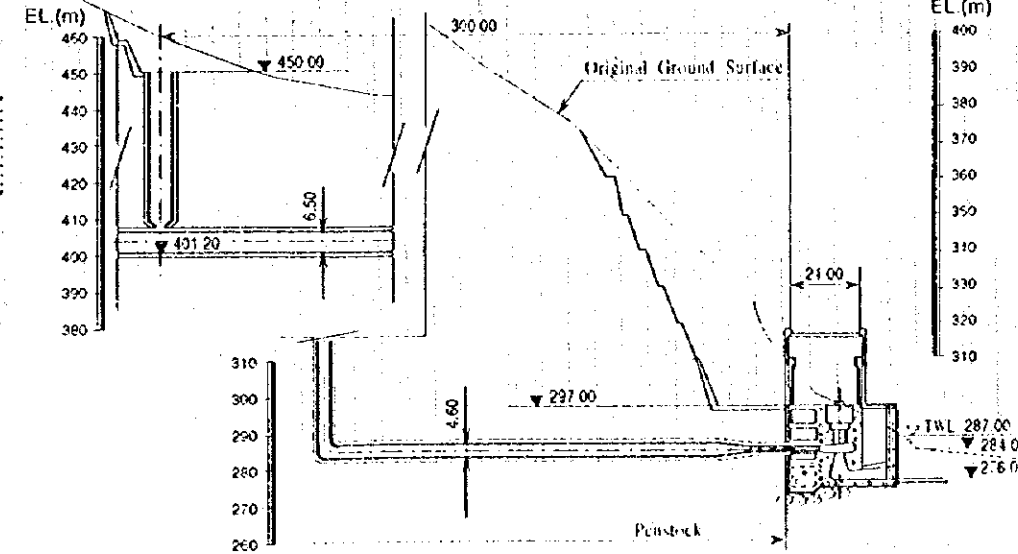
D : TYPICAL SECTION OF DAM



J : PLAN OF PENSTOCK AND POWERHOUSE

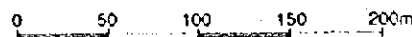
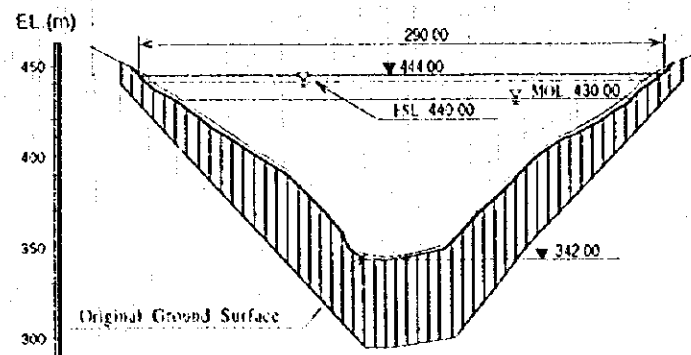


K : PROFILE OF SURGE TANK

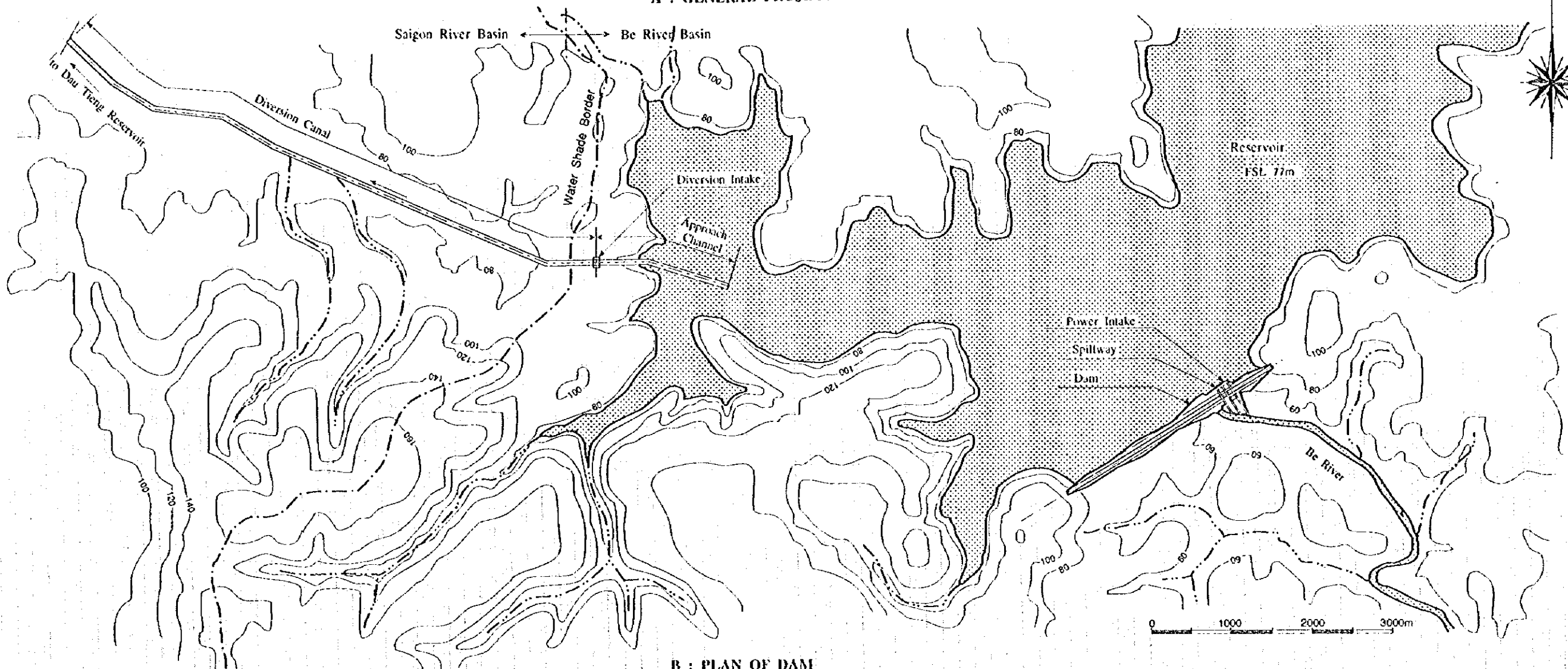


L : PROFILE OF POWERHOUSE

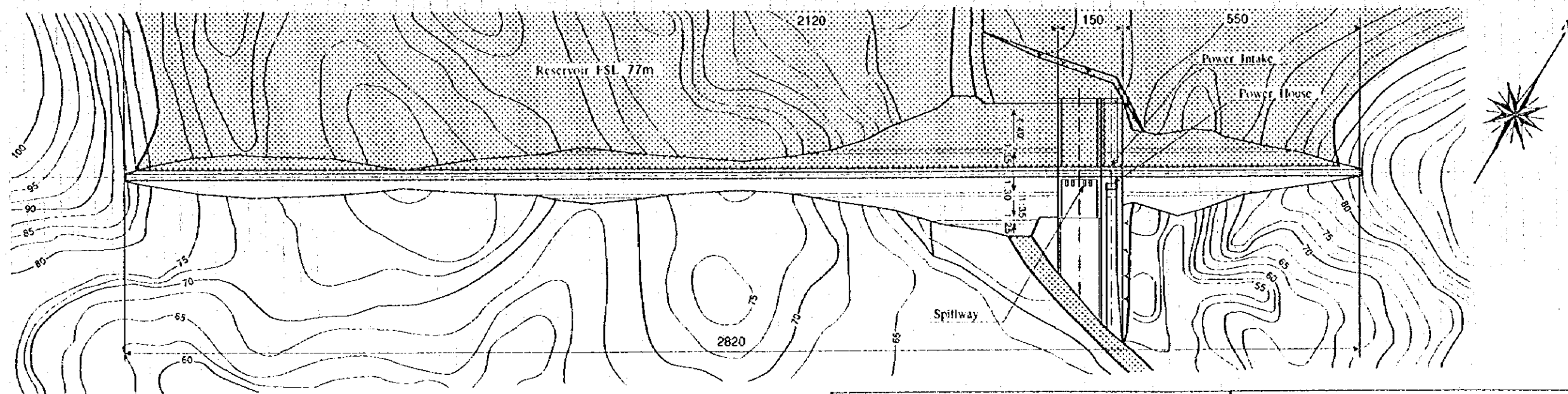
E : UPSTREAM ELEVATION OF DAM



**A : GENERAL PROJECT LAYOUT**



**B : PLAN OF DAM**

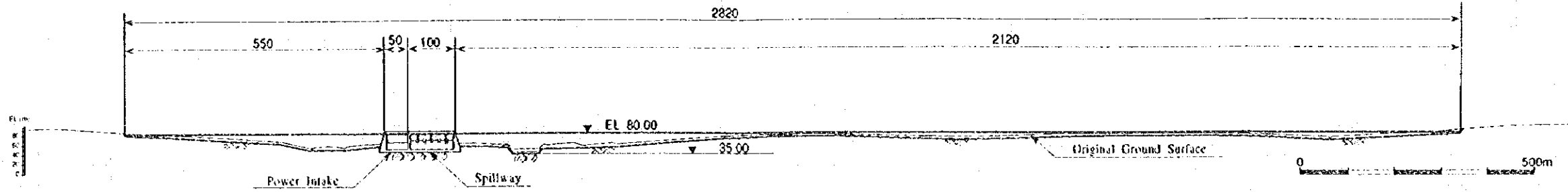


SOCIALIST REPUBLIC OF VIET NAM  
 MASTER PLAN STUDY ON DONG NAI RIVER  
 AND SURROUNDING BASINS  
 WATER RESOURCES DEVELOPMENT  
 JAPAN INTERNATIONAL COOPERATION AGENCY

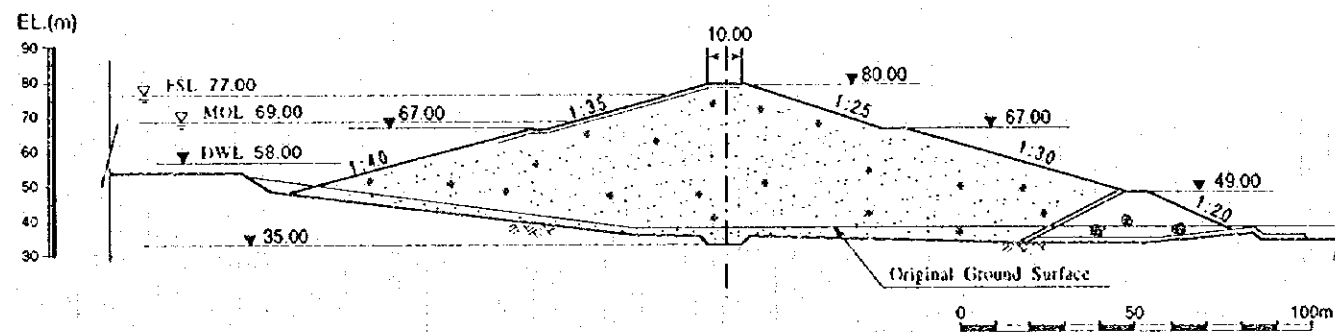
**Figure 9.3**  
 Basic Layout Design of  
 Fu Mieng Project (1/3)



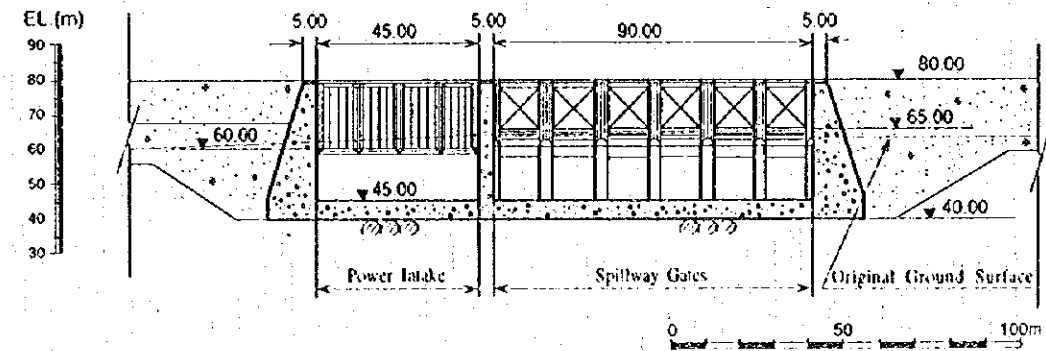
**C : UPSTREAM ELEVATION OF DAM**



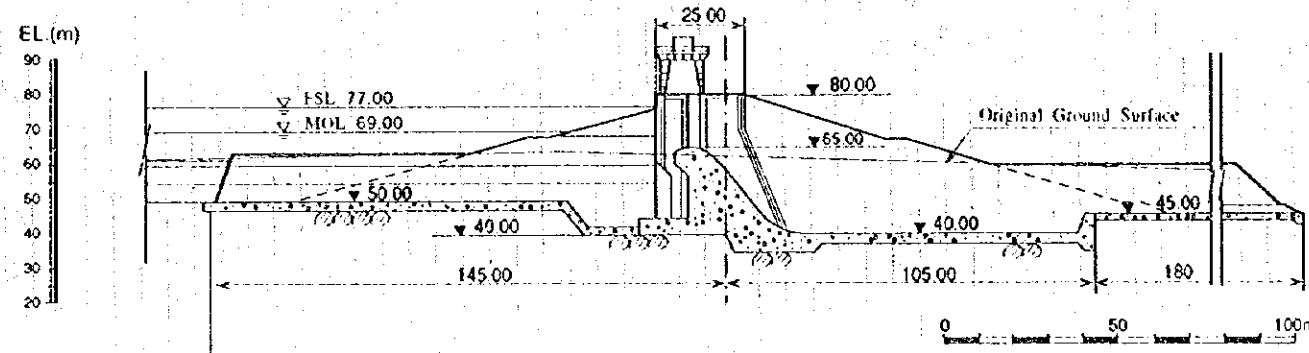
**D : TYPICAL SECTION OF DAM**



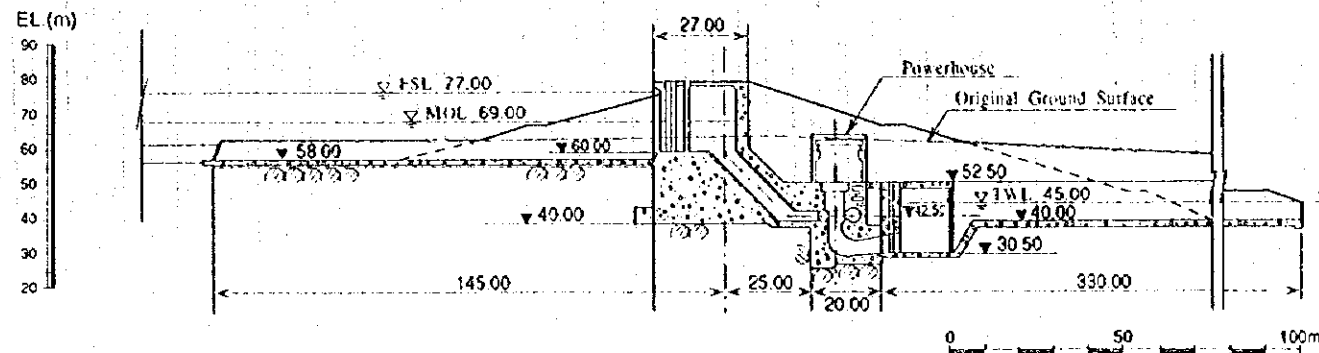
**G : UPSTREAM ELEVATION OF SPILLWAY AND POWER INTAKE**



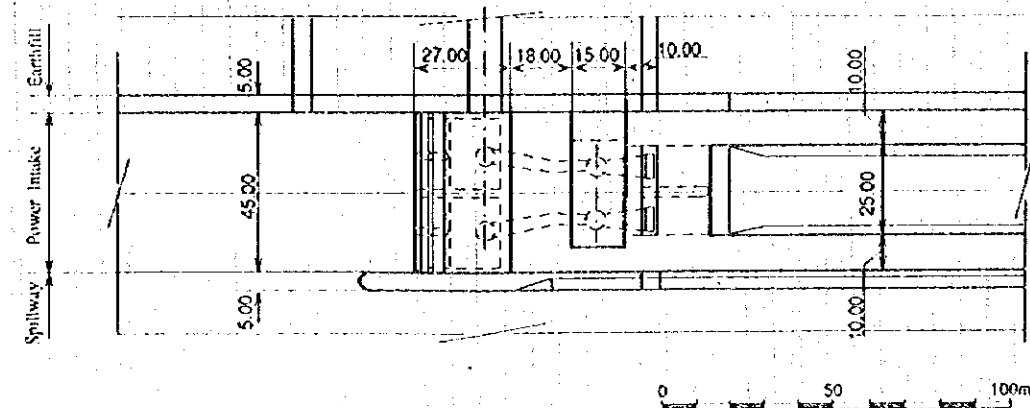
**E : PROFILE OF SPILLWAY**



**F : PROFILE OF INTAKE, POWERHOUSE AND TAILRACE**



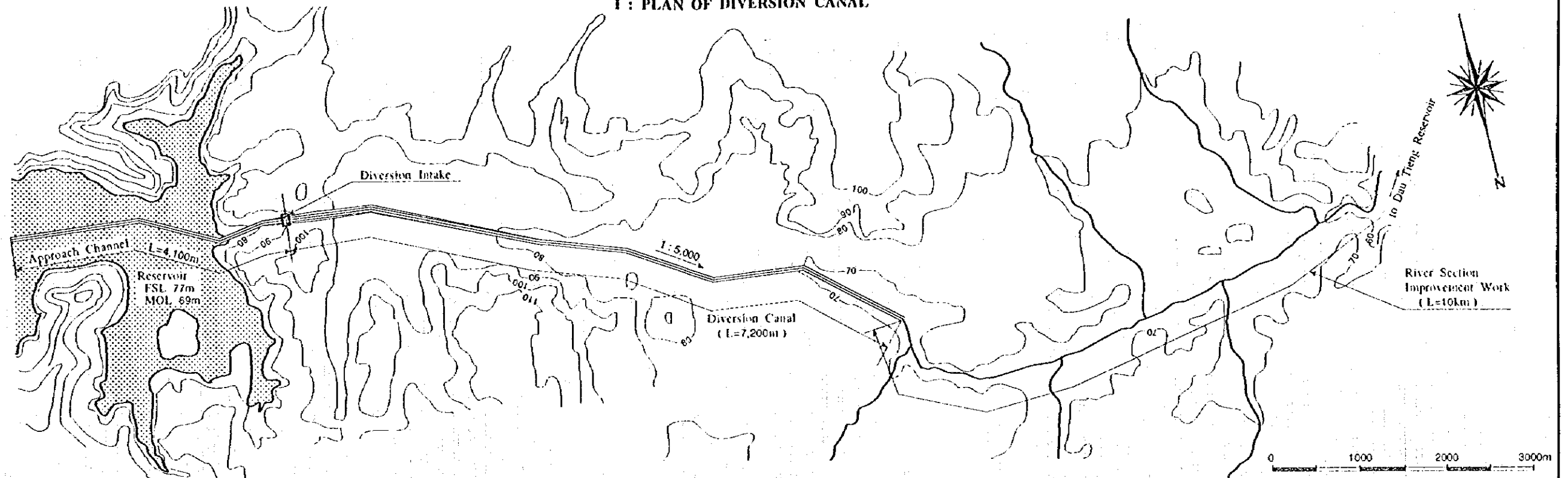
**H : PLAN OF POWER INTAKE AND POWERHOUSE**



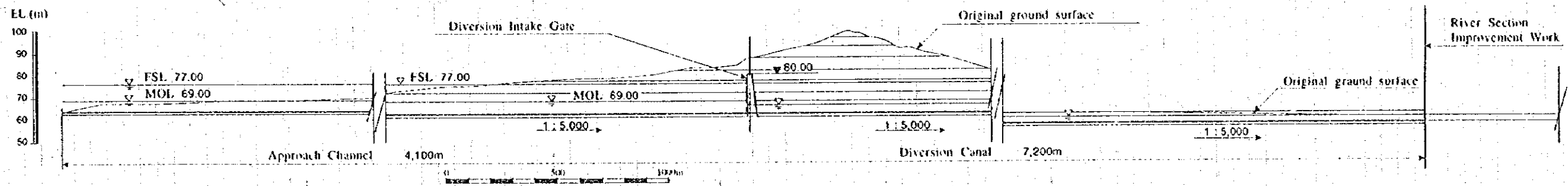
SOCIALIST REPUBLIC OF VIET NAM  
 MASTER PLAN STUDY ON DONG NAI RIVER  
 AND SURROUNDING BASINS  
 WATER RESOURCES DEVELOPMENT  
 JAPAN INTERNATIONAL COOPERATION AGENCY

**Figure 9.3**  
 Basic Layout Design of  
 Fu Mieng Project (2/3)

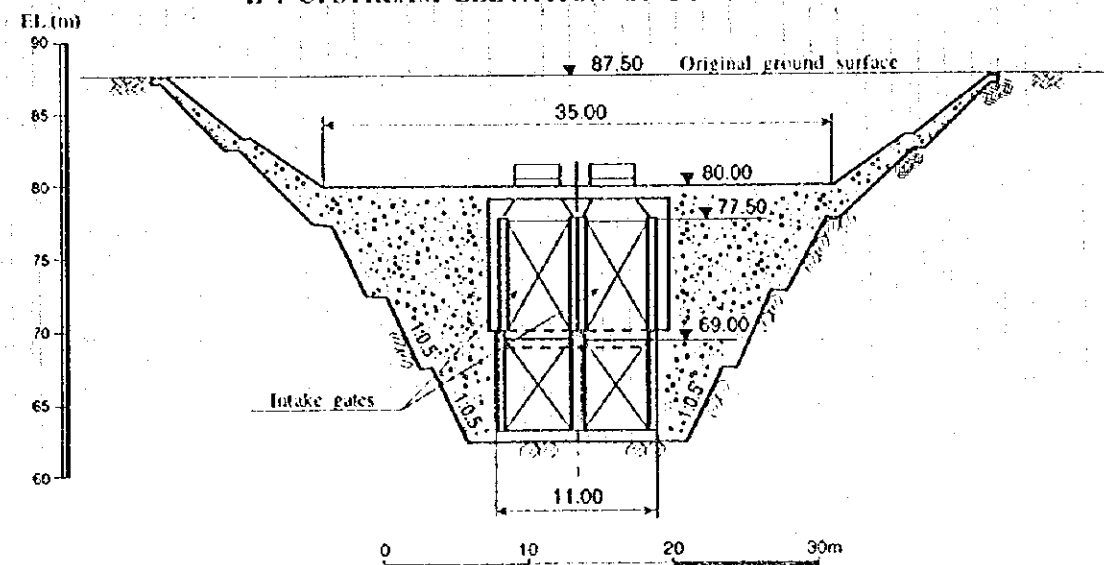
I : PLAN OF DIVERSION CANAL



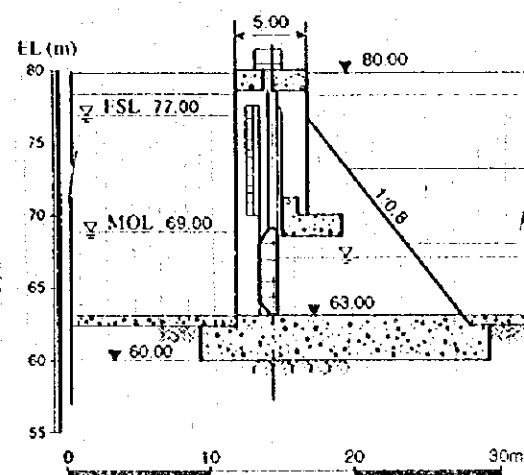
J : PROFILE OF DIVERSION CANAL



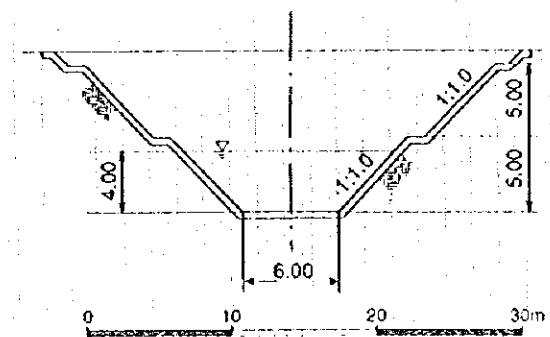
L : UPSTREAM ELEVATION OF DIVERSION INTAKE

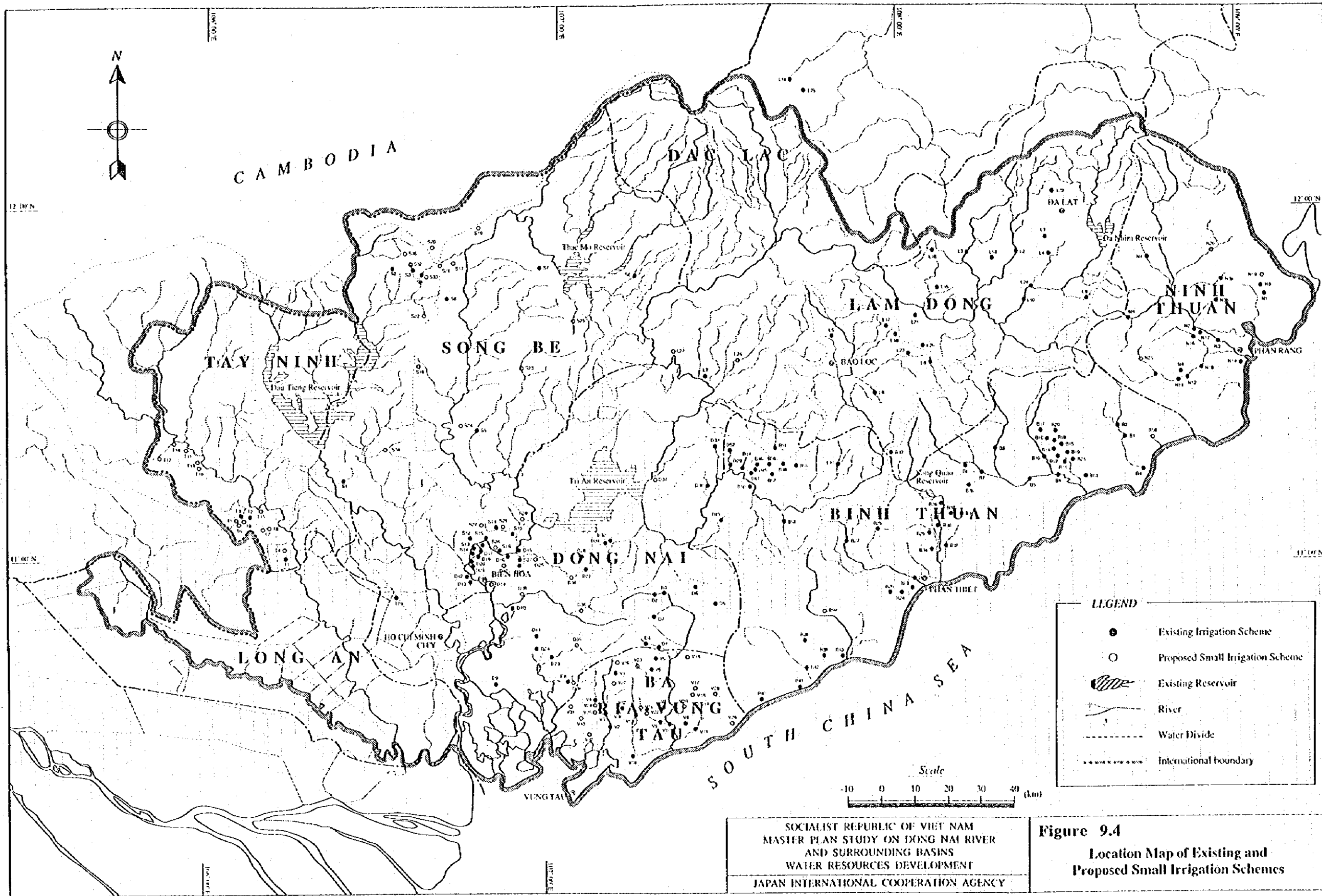


K : PROFILE OF DIVERSION INTAKE



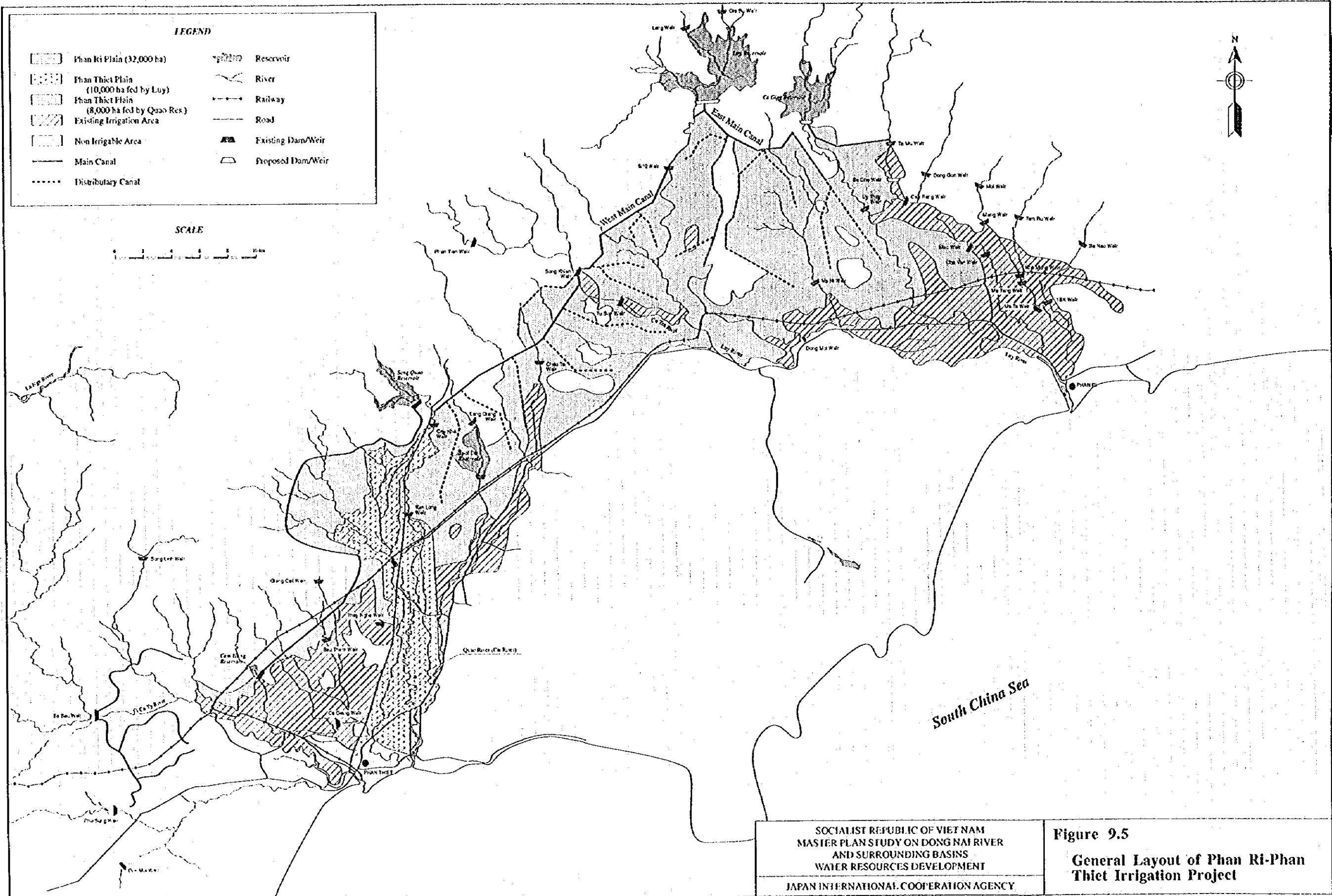
M : TYPICAL SECTION OF CANAL





SOCIALIST REPUBLIC OF VIET NAM  
 MASTER PLAN STUDY ON DONG NAI RIVER  
 AND SURROUNDING BASINS  
 WATER RESOURCES DEVELOPMENT  
 JAPAN INTERNATIONAL COOPERATION AGENCY

**Figure 9.4**  
 Location Map of Existing and  
 Proposed Small Irrigation Schemes



**LEGEND**

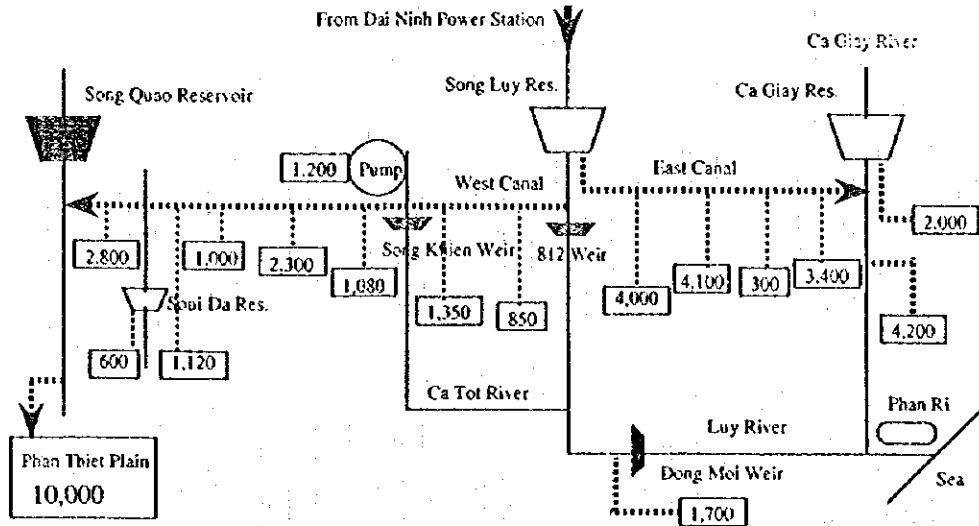
[Stippled Area]	Phan Ri Plain (32,000 ha)	[Wavy Line]	Reservoir
[Dotted Area]	Phan Thiet Plain (10,000 ha fed by Luy)	[Line]	River
[Cross-hatched Area]	Phan Thiet Plain (8,000 ha fed by Quao Res.)	[Line with Cross-ticks]	Railway
[Diagonal Lines]	Existing Irrigation Area	[Line with Dots]	Road
[White Area]	Non Irrigable Area	[Thick Line]	Existing Dam/Weir
[Solid Line]	Main Canal	[Thin Line]	Proposed Dam/Weir
[Dashed Line]	Distributary Canal		



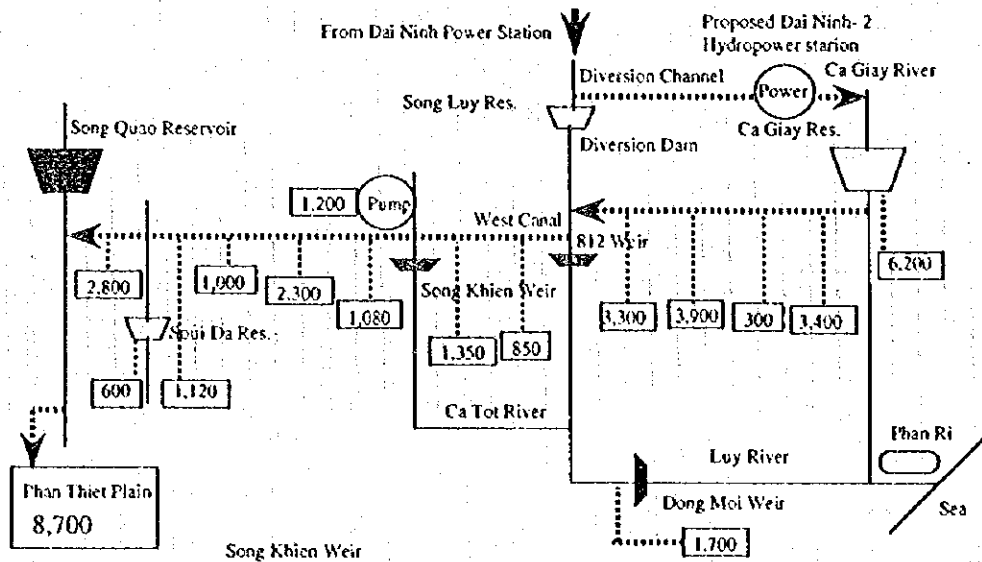
SOCIALIST REPUBLIC OF VIET NAM  
 MASTER PLAN STUDY ON DONG NAI RIVER  
 AND SURROUNDING BASINS  
 WATER RESOURCES DEVELOPMENT  
 JAPAN INTERNATIONAL COOPERATION AGENCY

**Figure 9.5**  
**General Layout of Phan Ri-Phan Thiet Irrigation Project**

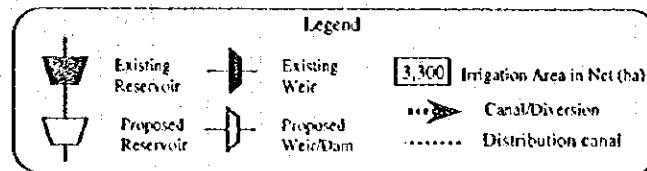
Figure 2.41 Irrigation System Diagram of Phan Ri - Phan Thiet Irrigation Project



Alt-1: Irrigation System Diagram with Luy and Ca Giay Reservoirs

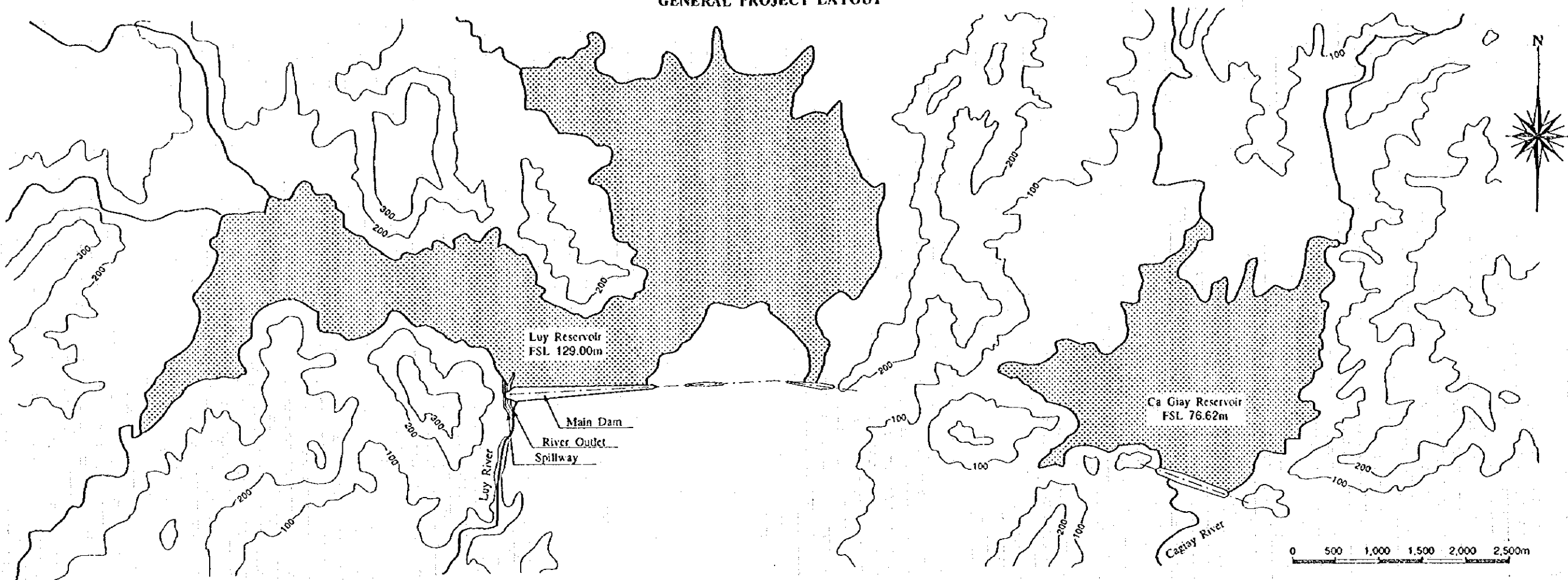


Alt-2: Irrigation System Diagram with Ca Giay Reservoir Only

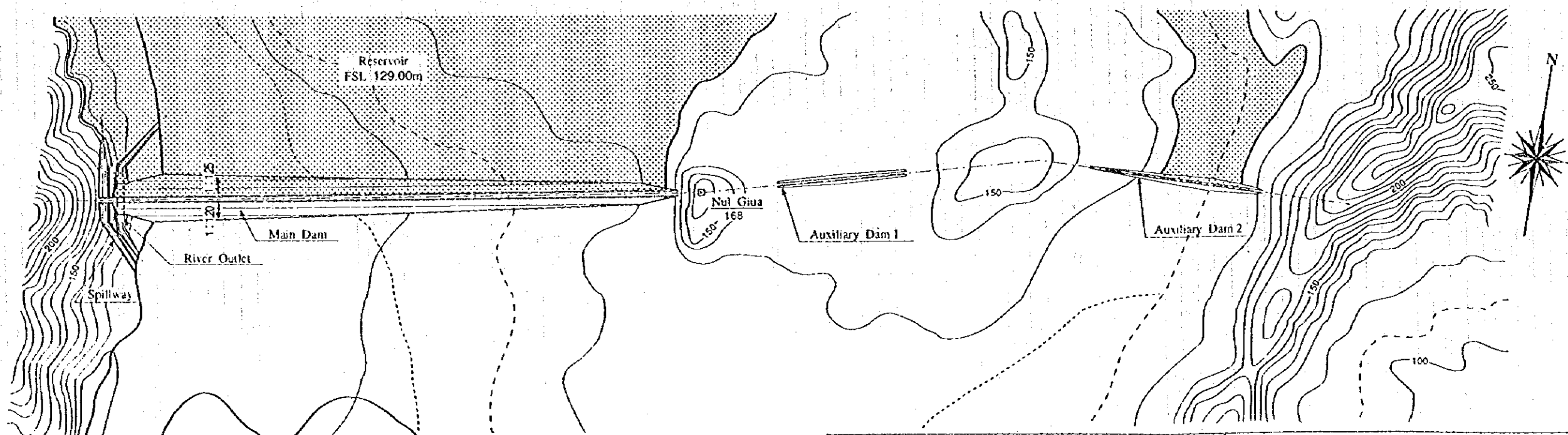




GENERAL PROJECT LAYOUT



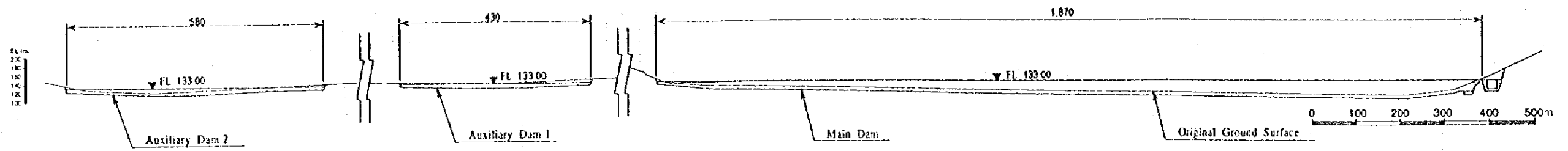
PLAN OF DAM



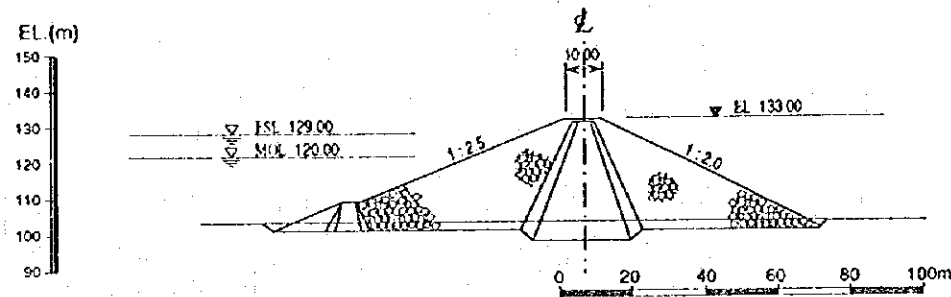
SOCIALIST REPUBLIC OF VIET NAM  
 MASTER PLAN STUDY ON DONG NAI RIVER  
 AND SURROUNDING BASINS  
 WATER RESOURCES DEVELOPMENT  
 JAPAN INTERNATIONAL COOPERATION AGENCY

Figure 9.7  
 Preliminary Design of Luy Dam (1/2)

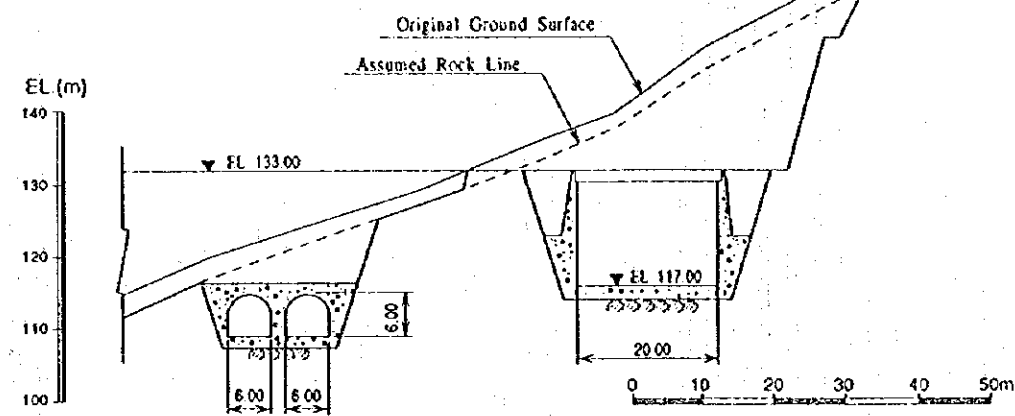
UPSTREAM ELEVATION OF DAM



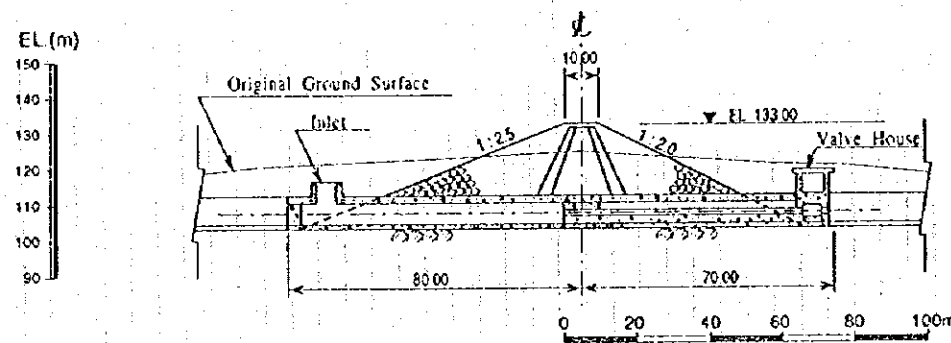
TYPICAL SECTION OF DAM



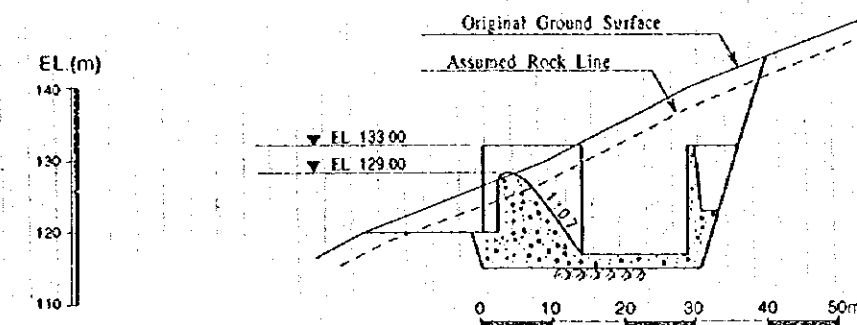
TYPICAL SECTION OF RIVER OUTLET AND SPILLWAY



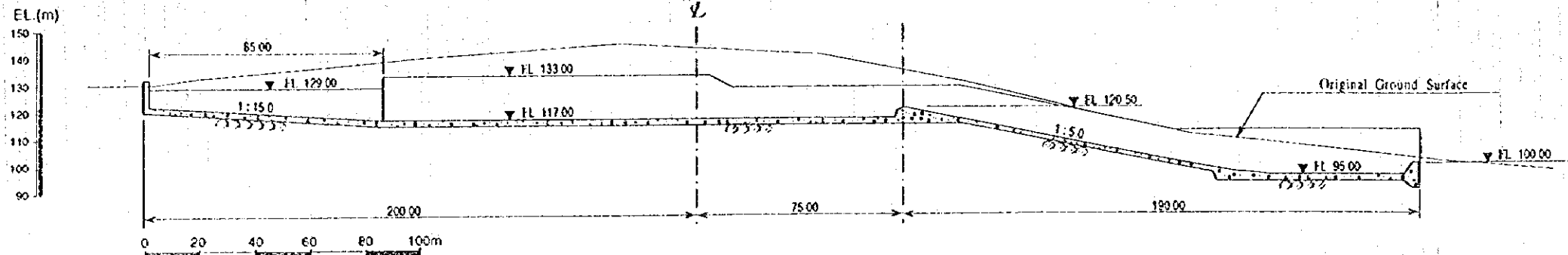
PROFILE OF RIVER OUTLET



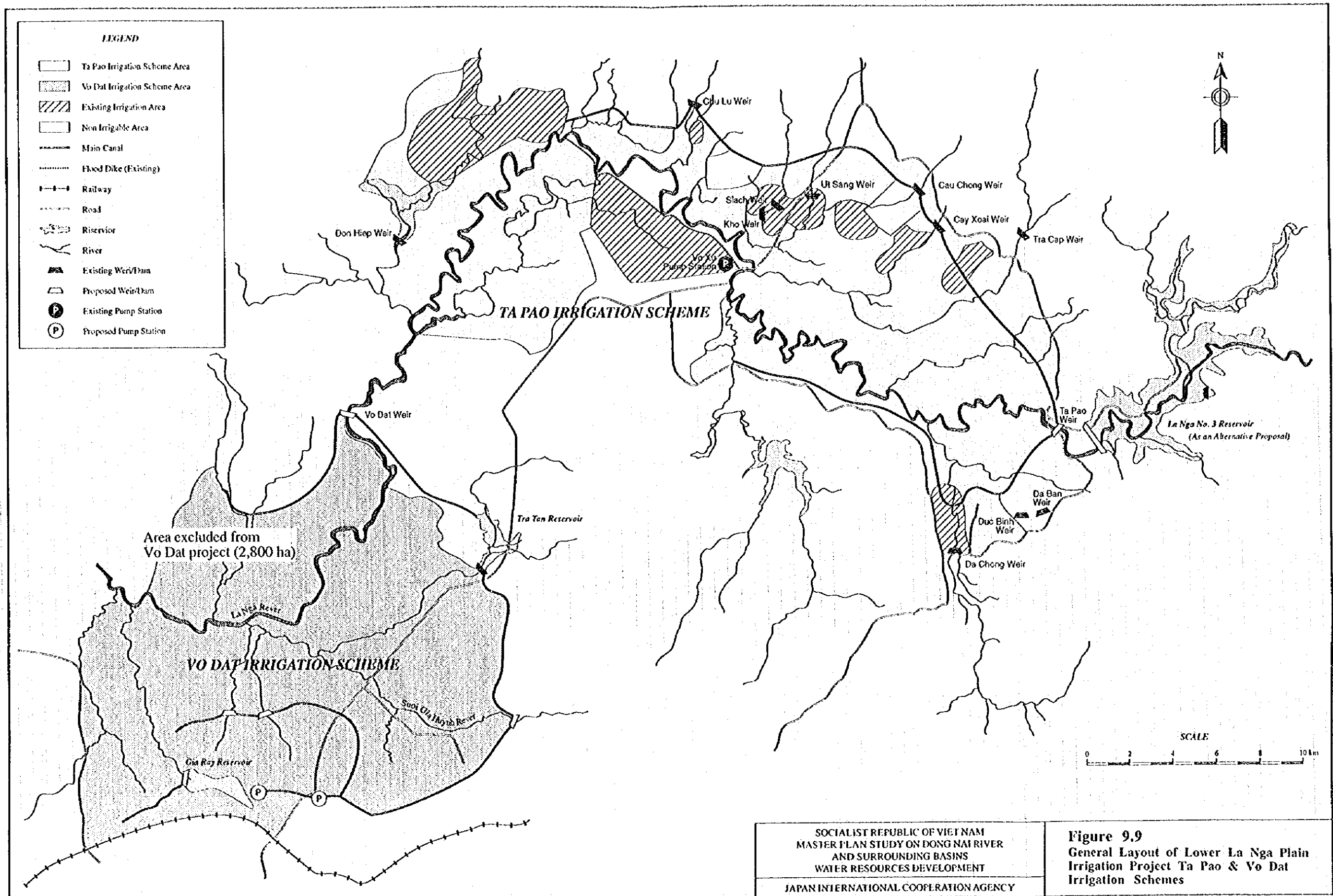
TYPICAL OVERFLOW SECTION OF SPILLWAY

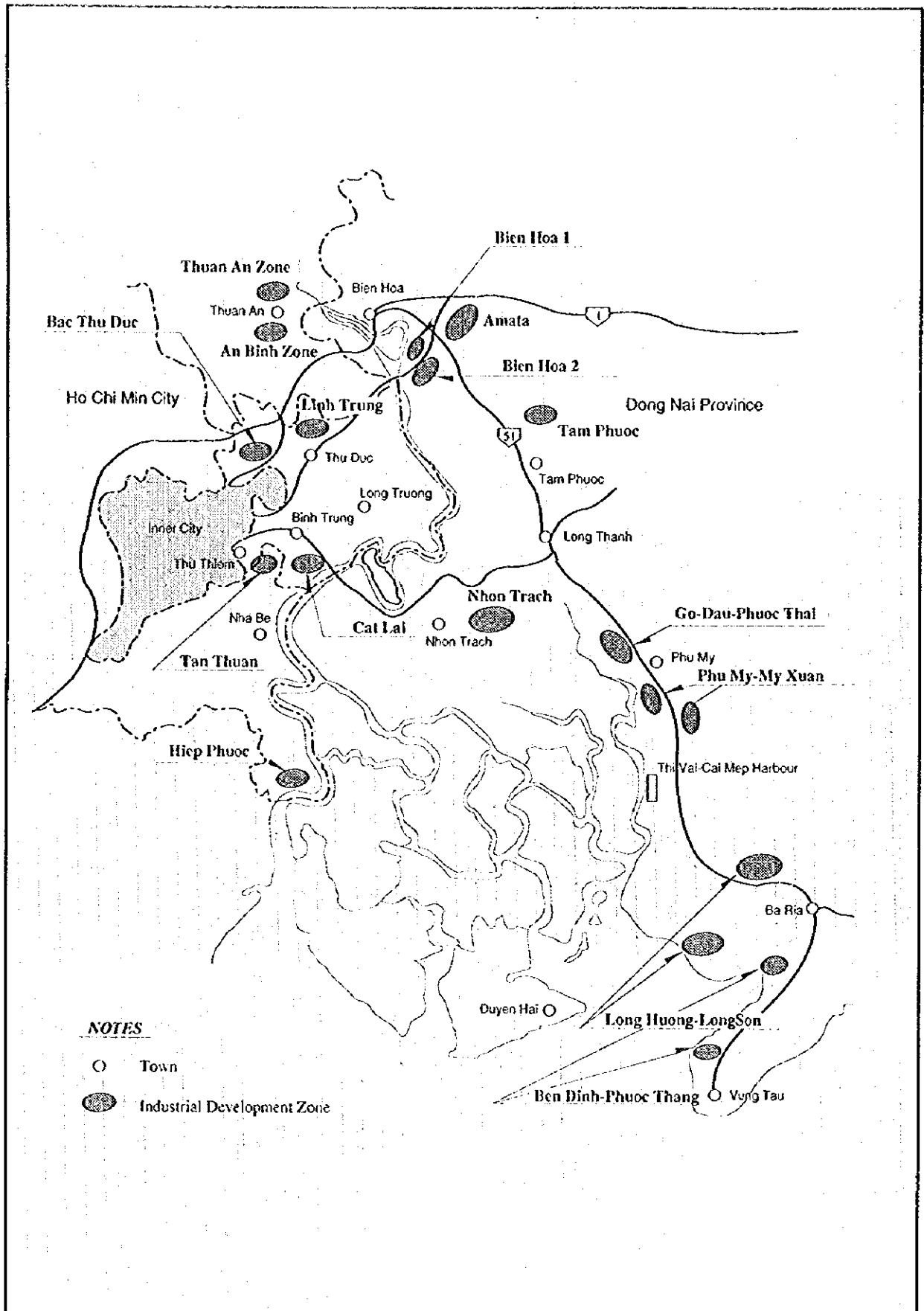


PROFILE OF SPILLWAY



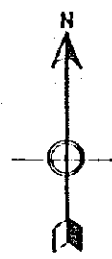
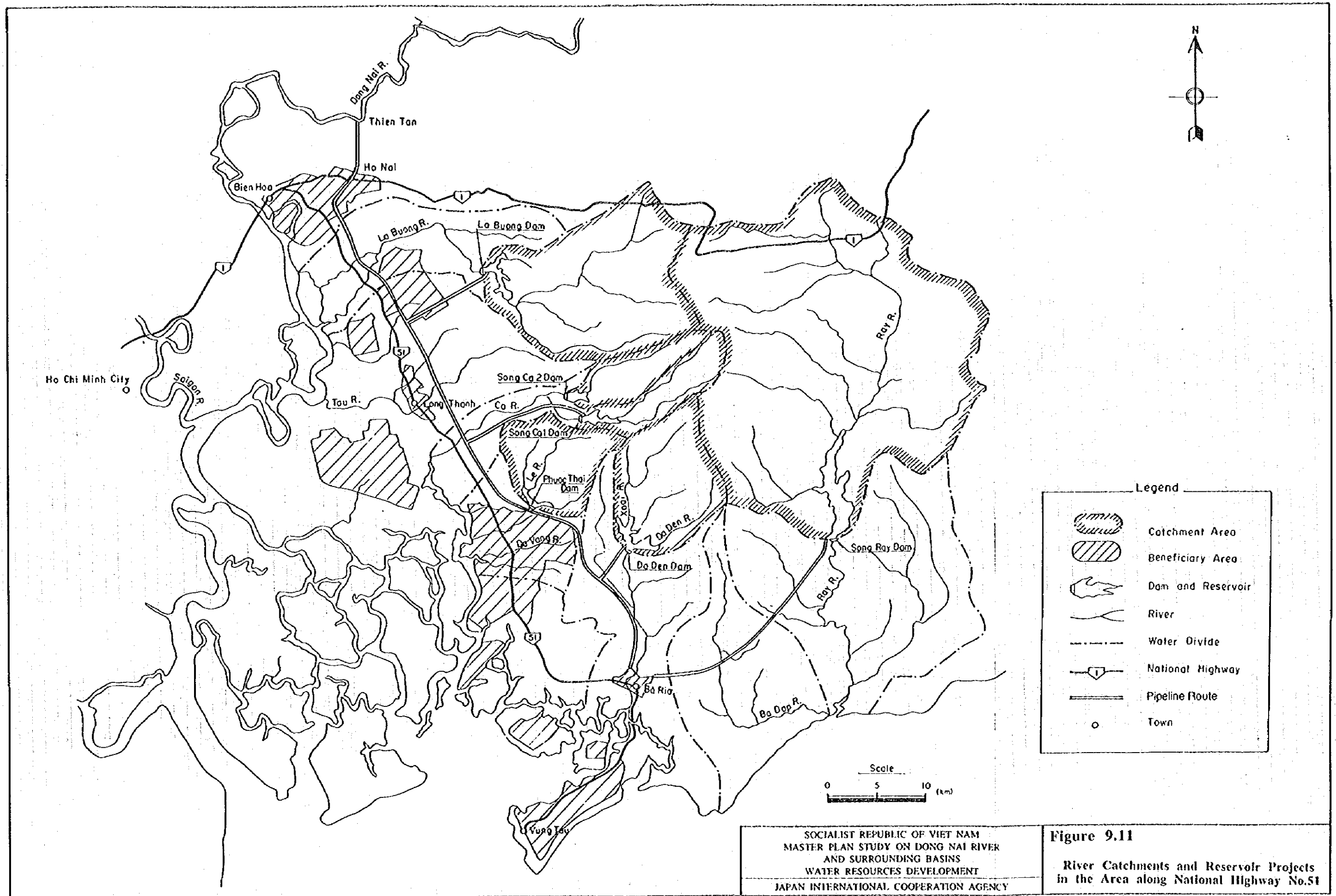




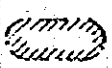
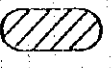
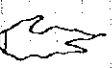
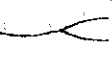
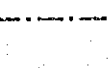





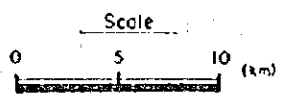
**Figure 9.10**  
**Industrial Development Zones in the Study Area**





**Legend**

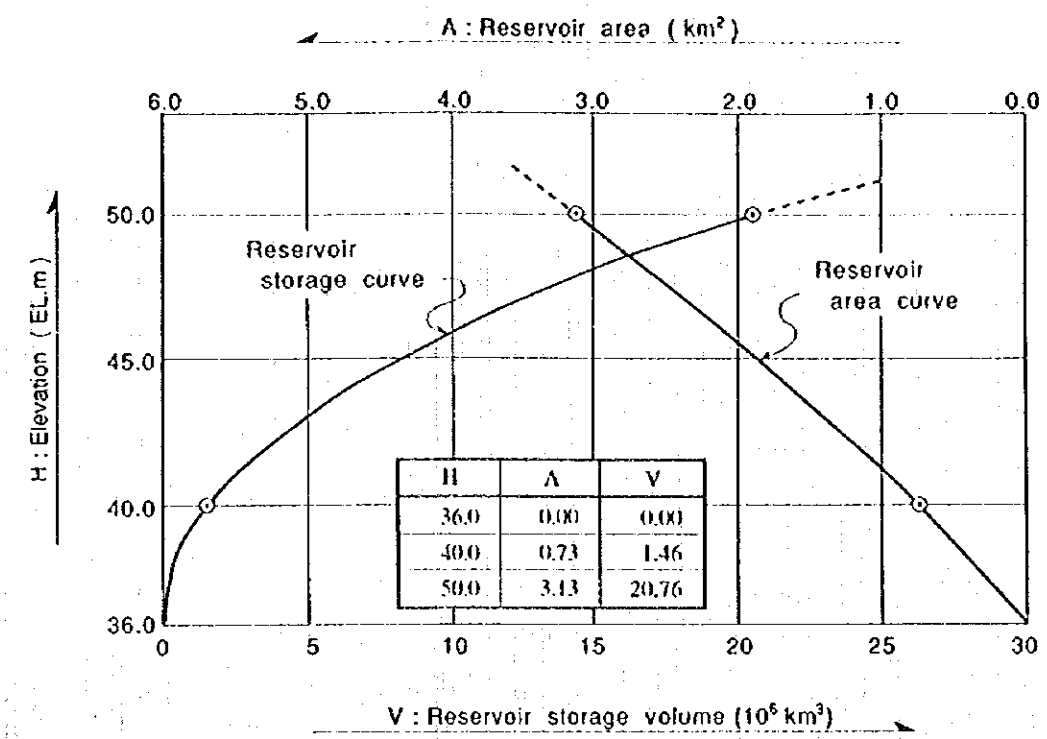
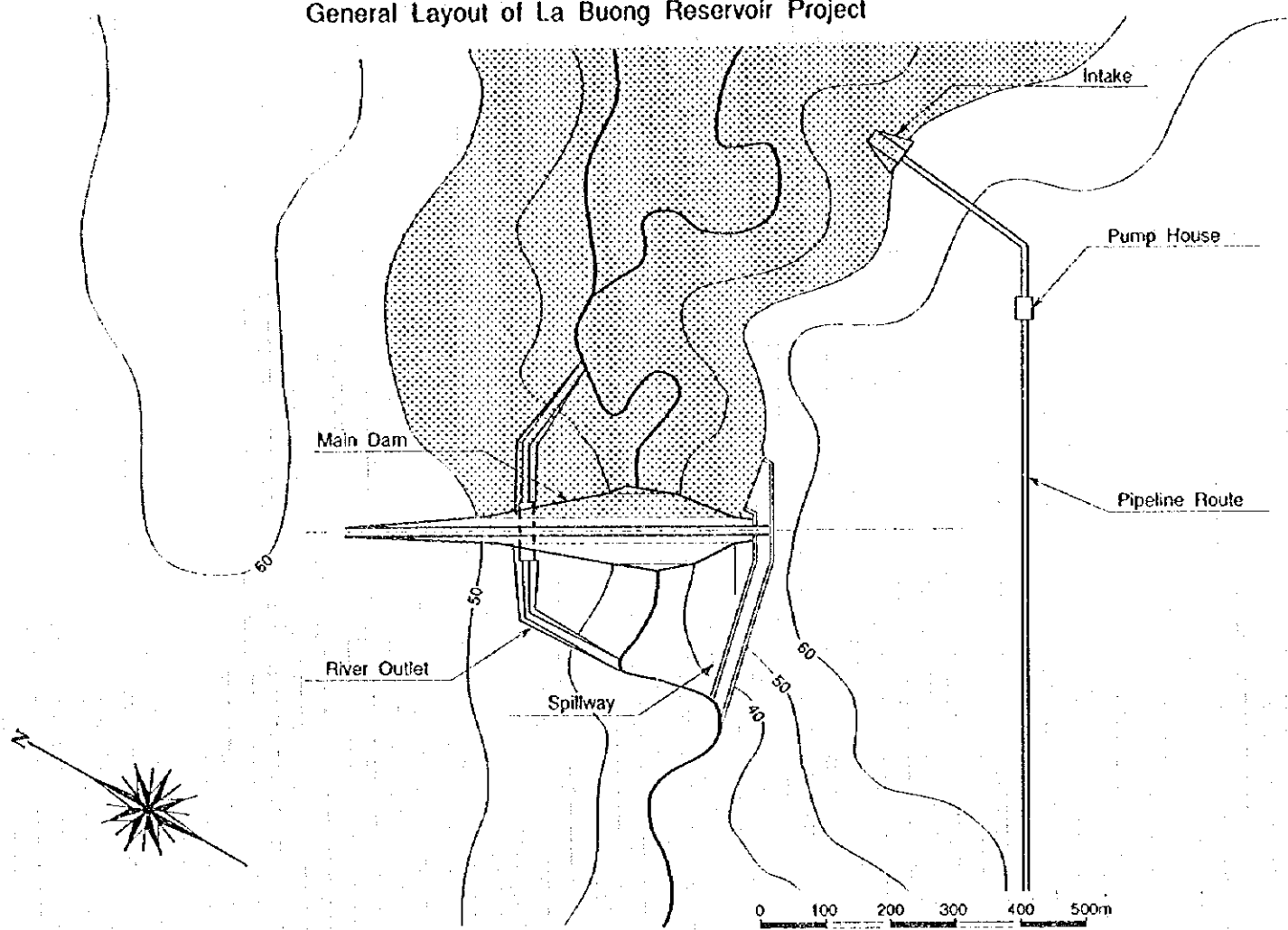
-  Catchment Area
-  Beneficiary Area
-  Dam and Reservoir
-  River
-  Water Divide
-  National Highway
-  Pipeline Route
-  Town



SOCIALIST REPUBLIC OF VIET NAM  
 MASTER PLAN STUDY ON DONG NAI RIVER  
 AND SURROUNDING BASINS  
 WATER RESOURCES DEVELOPMENT  
 JAPAN INTERNATIONAL COOPERATION AGENCY

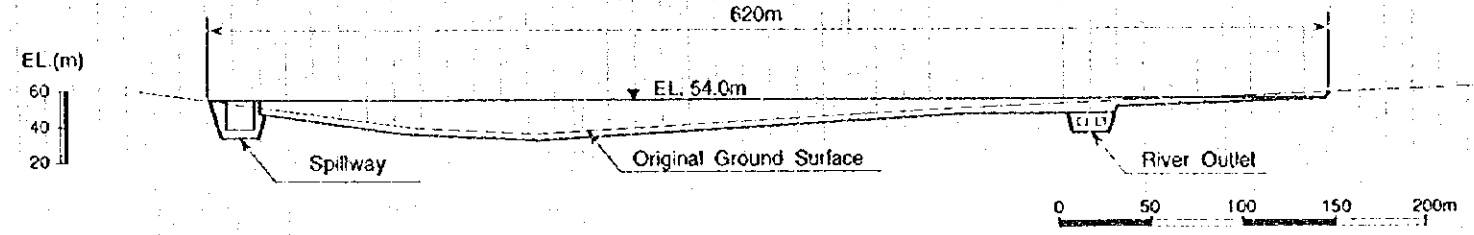
**Figure 9.11**  
 River Catchments and Reservoir Projects  
 in the Area along National Highway No.51

### General Layout of La Buong Reservoir Project



Reservoir Storage Volume Curve and Reservoir Area Curve

### Upstream Elevation of Main Dam



### Typical Section of Main Dam

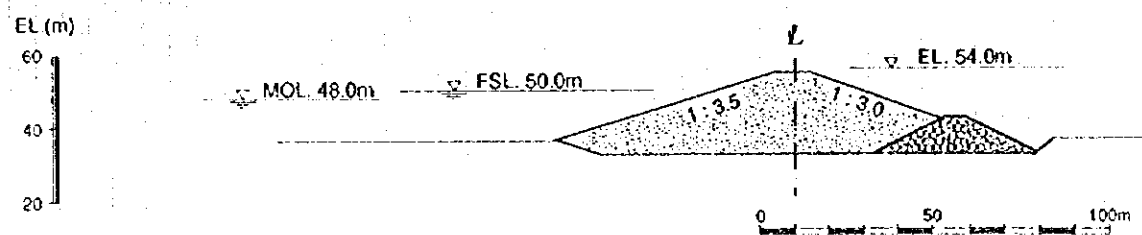
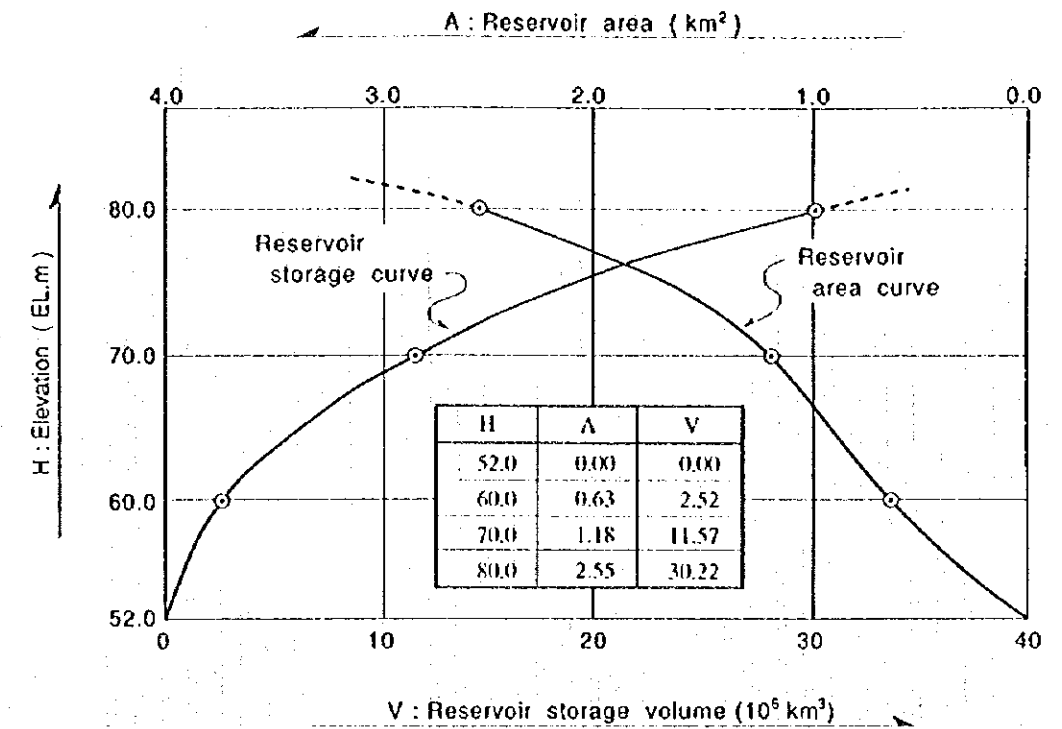
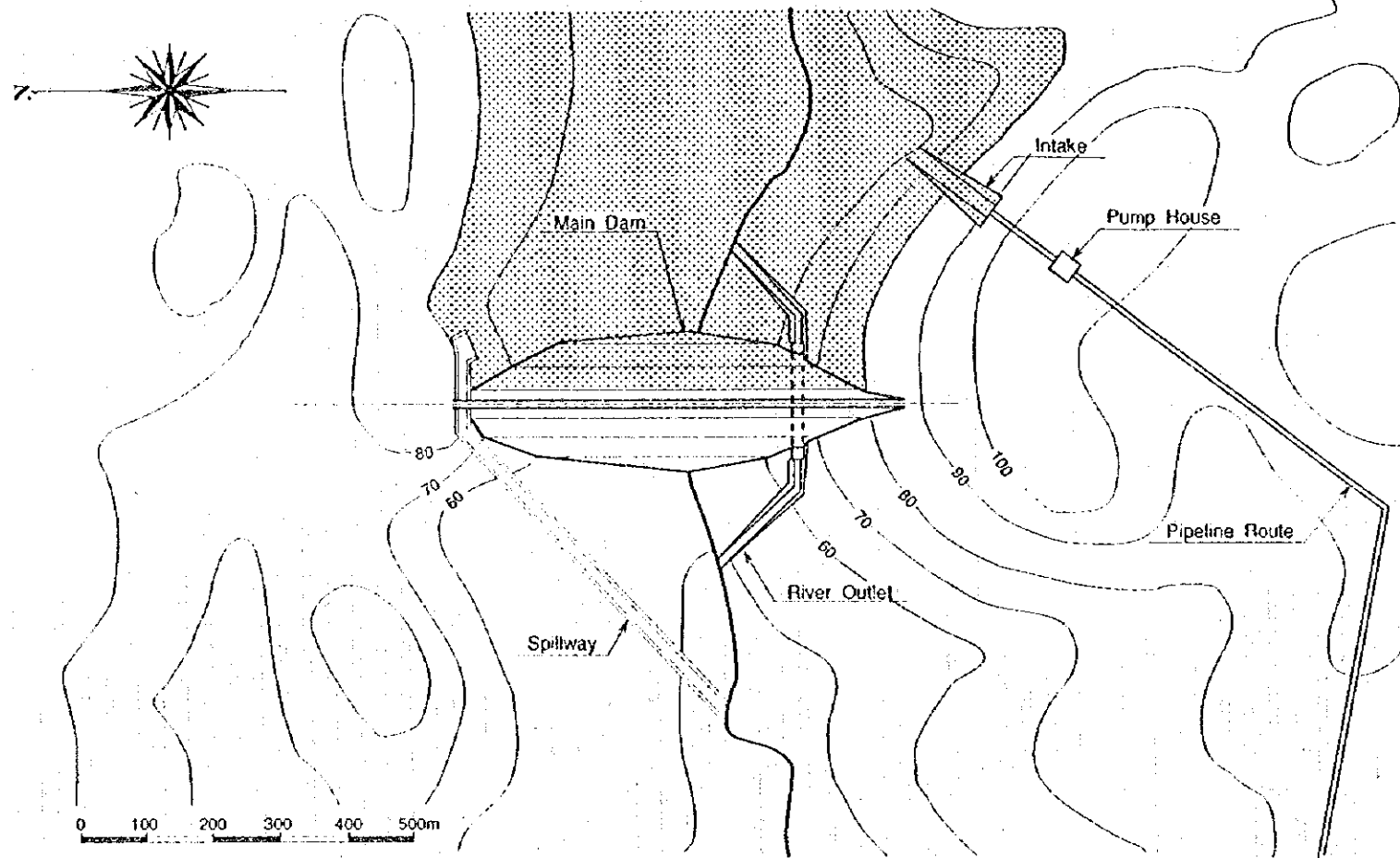


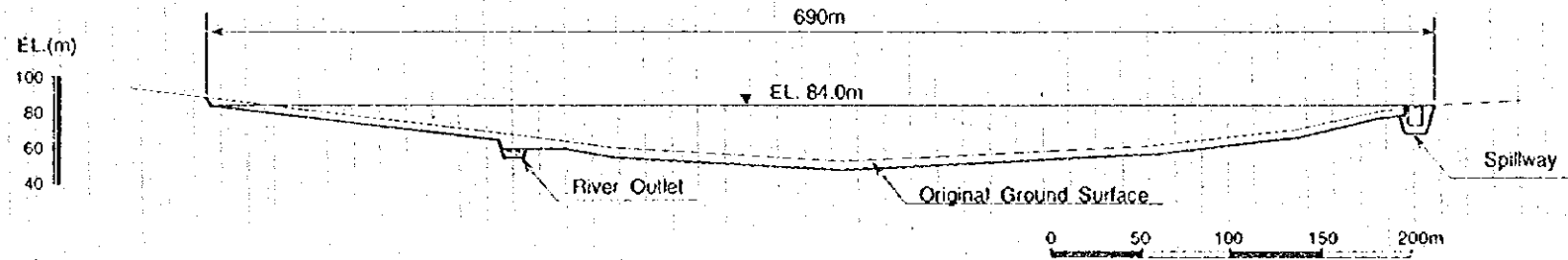
Figure 9.12  
 Preliminary Development Plan of  
 La Buong Reservoir Project

General Layout of Song Ca-1 Reservoir Project

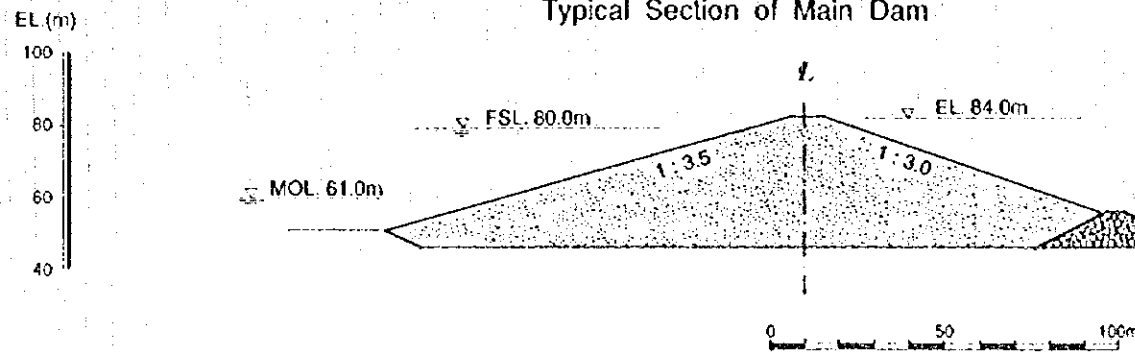


Reservoir Storage Volume Curve and Reservoir Area Curve

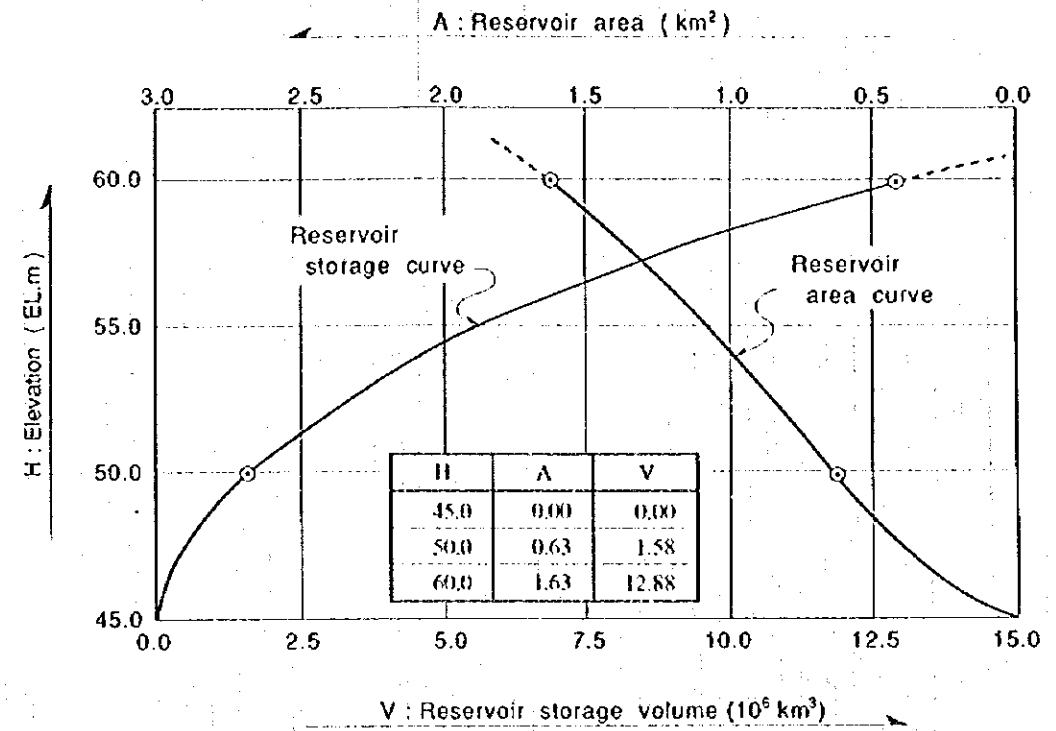
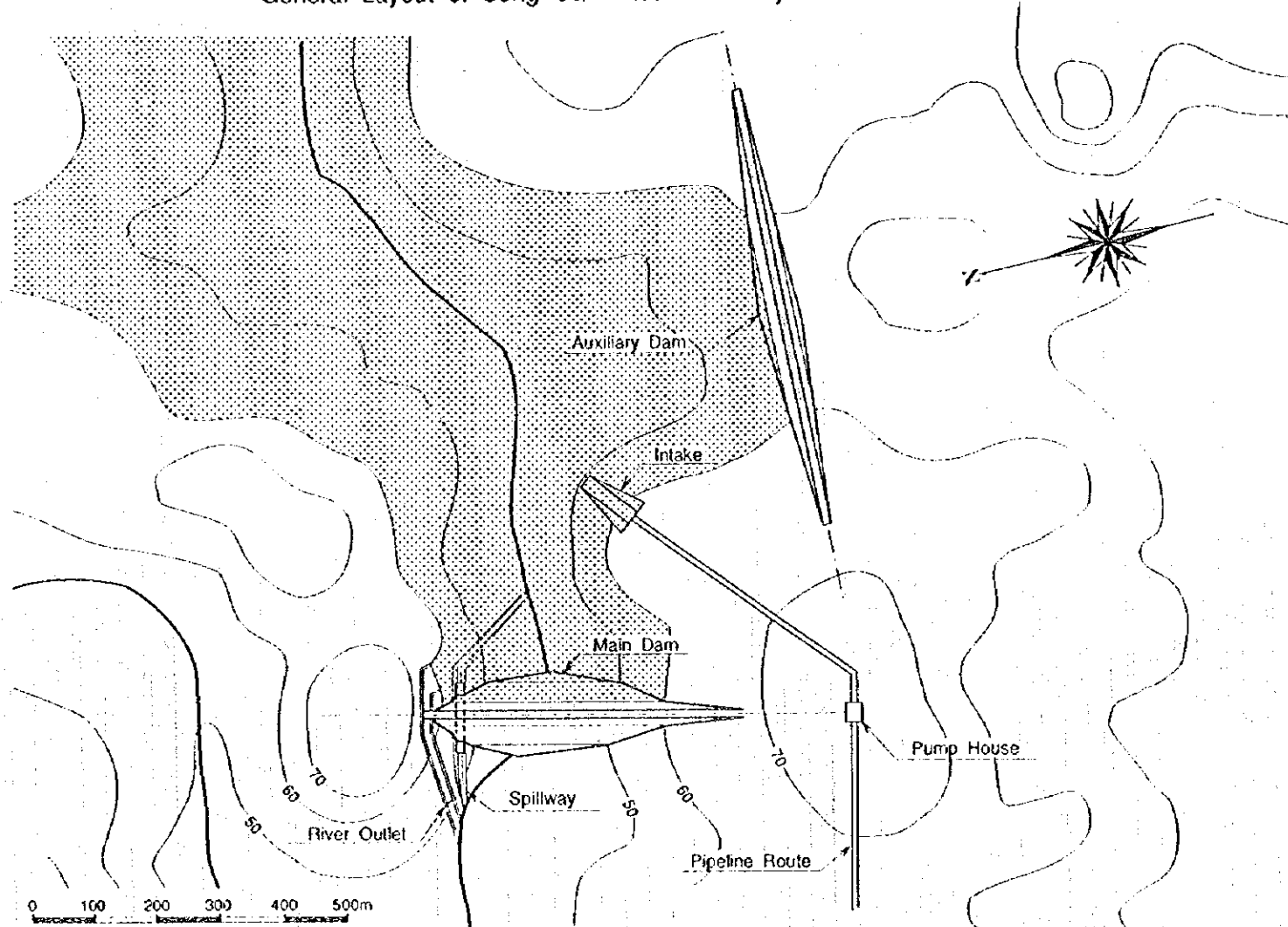
Upstream Elevation of Main Dam



Typical Section of Main Dam

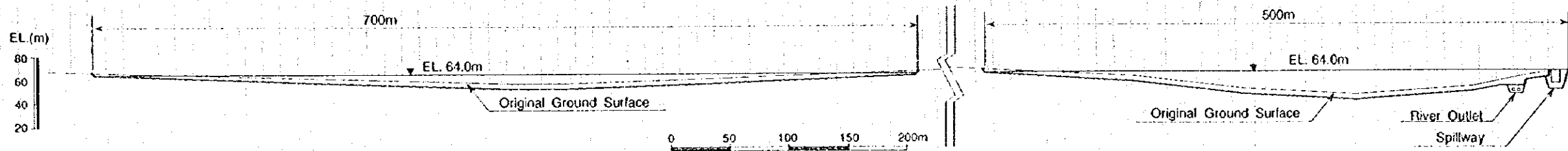


General Layout of Song Ca-2 Reservoir Project

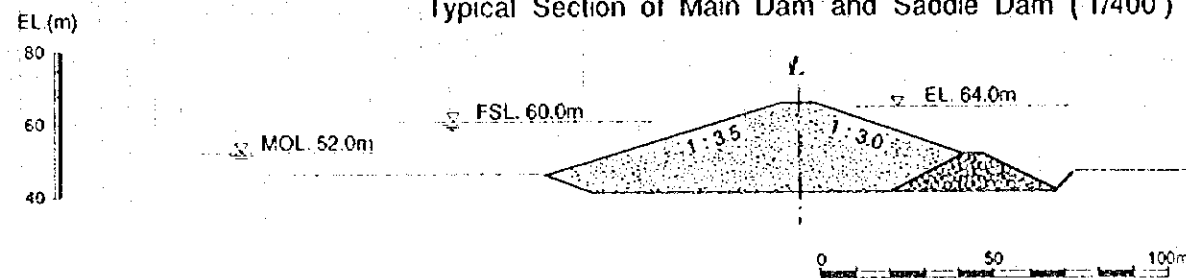


Reservoir Storage Volume Curve and Reservoir Area Curve

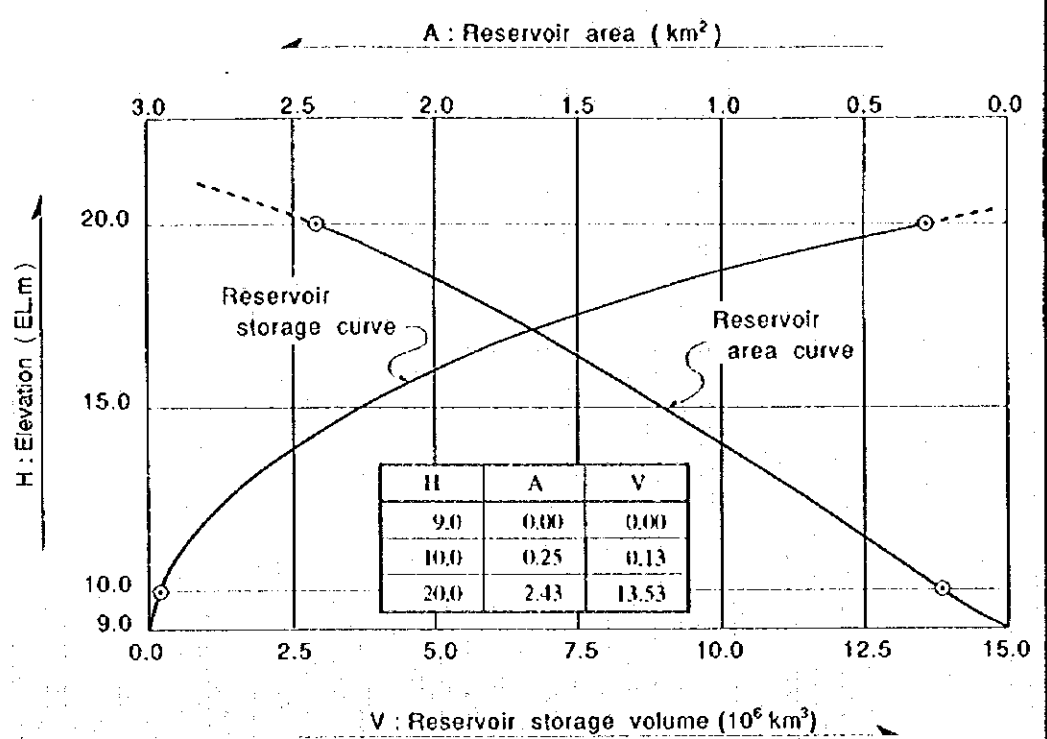
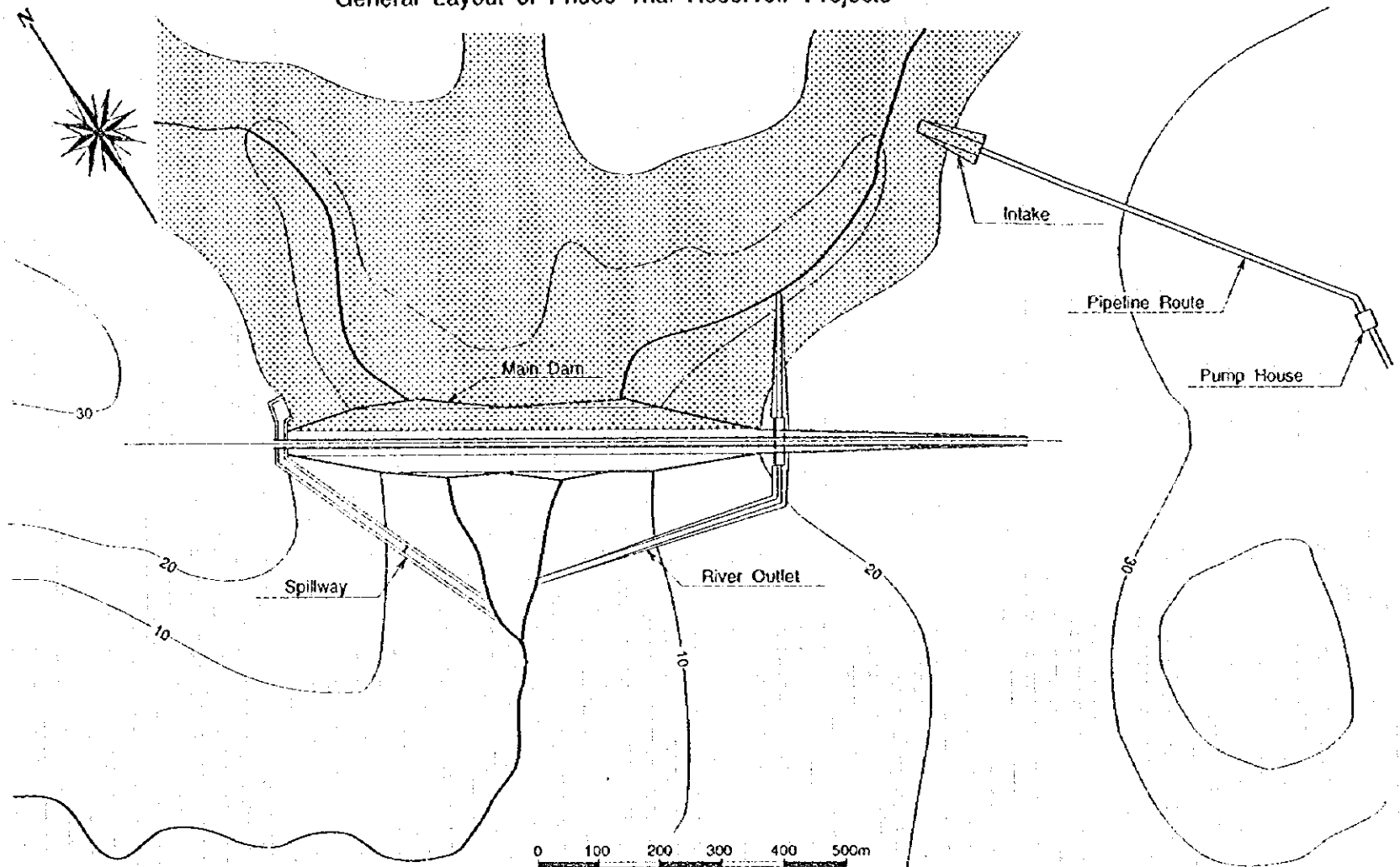
Upstream Elevation of Main Dam and Saddle Dam



Typical Section of Main Dam and Saddle Dam (1/400)

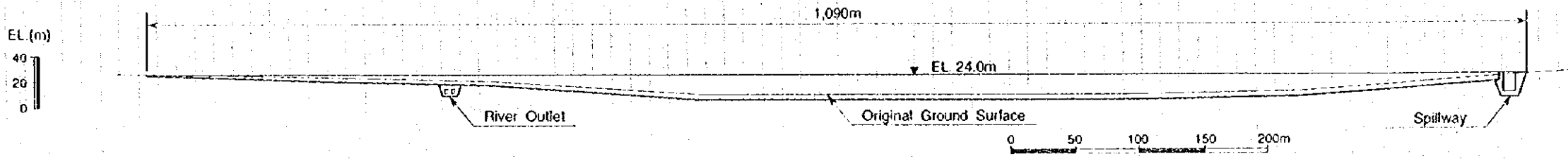


General Layout of Phuoc Thai Reservoir Projects

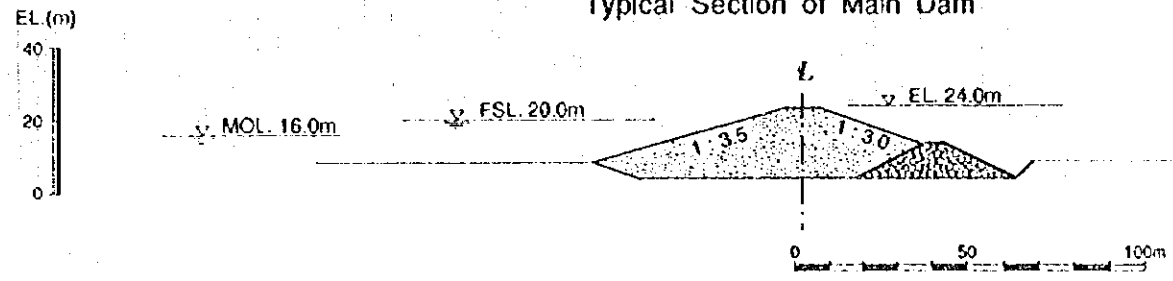


Reservoir Storage Volume Curve and Reservoir Area Curve

Upstream Elevation of Main Dam

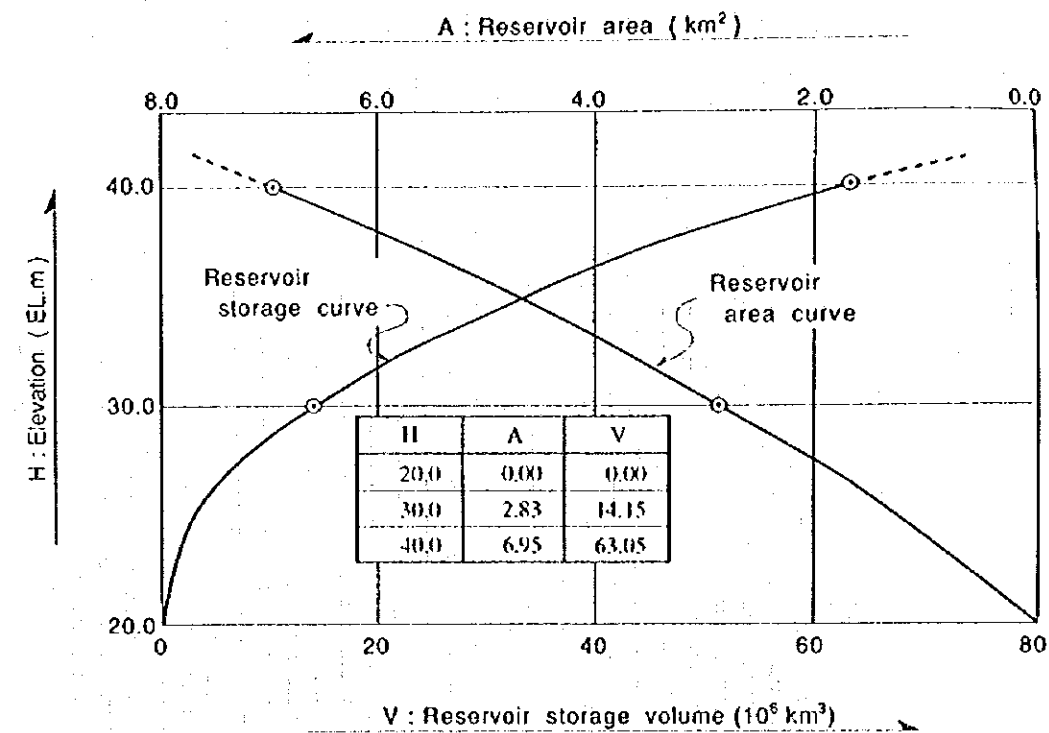
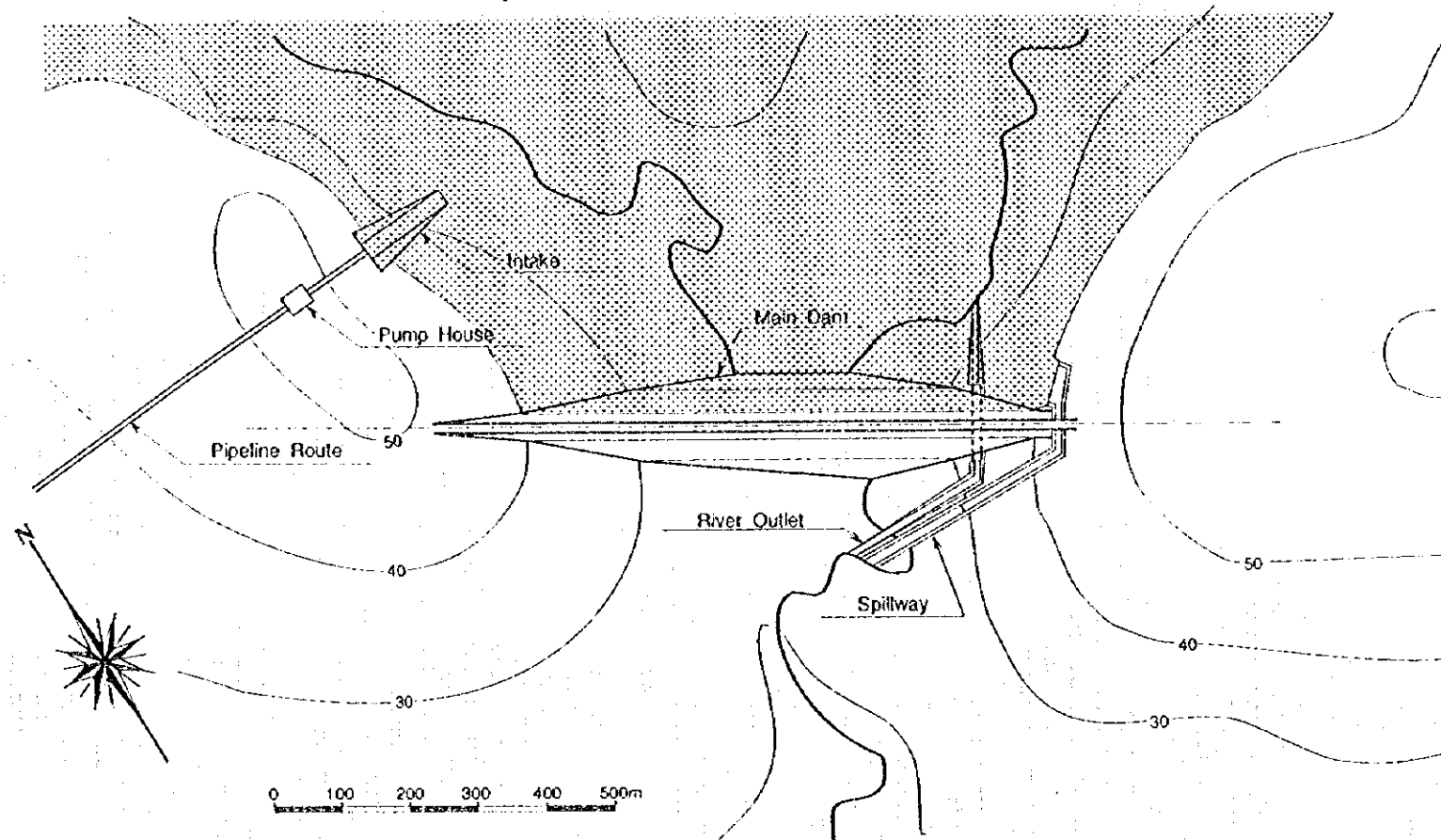


Typical Section of Main Dam



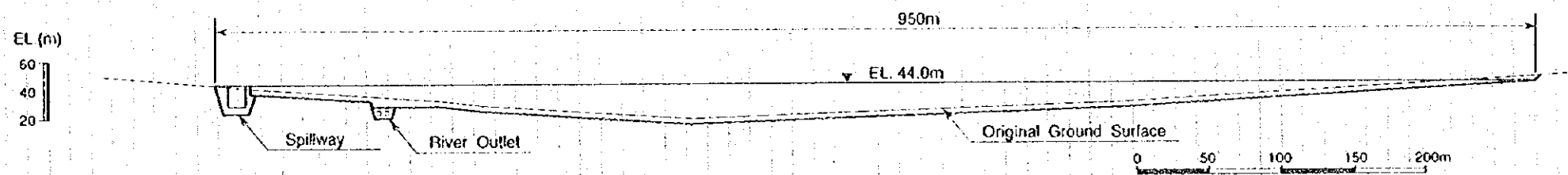


General Layout of Da Den Reservoir Project

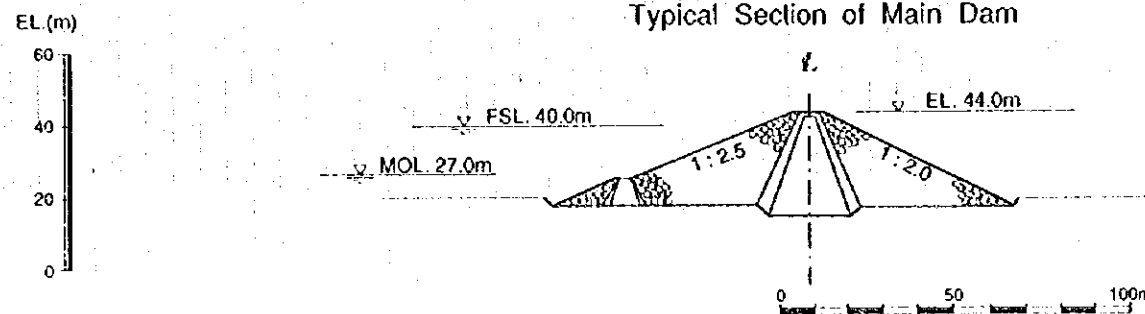


Reservoir Storage Volume Curve and Reservoir Area Curve

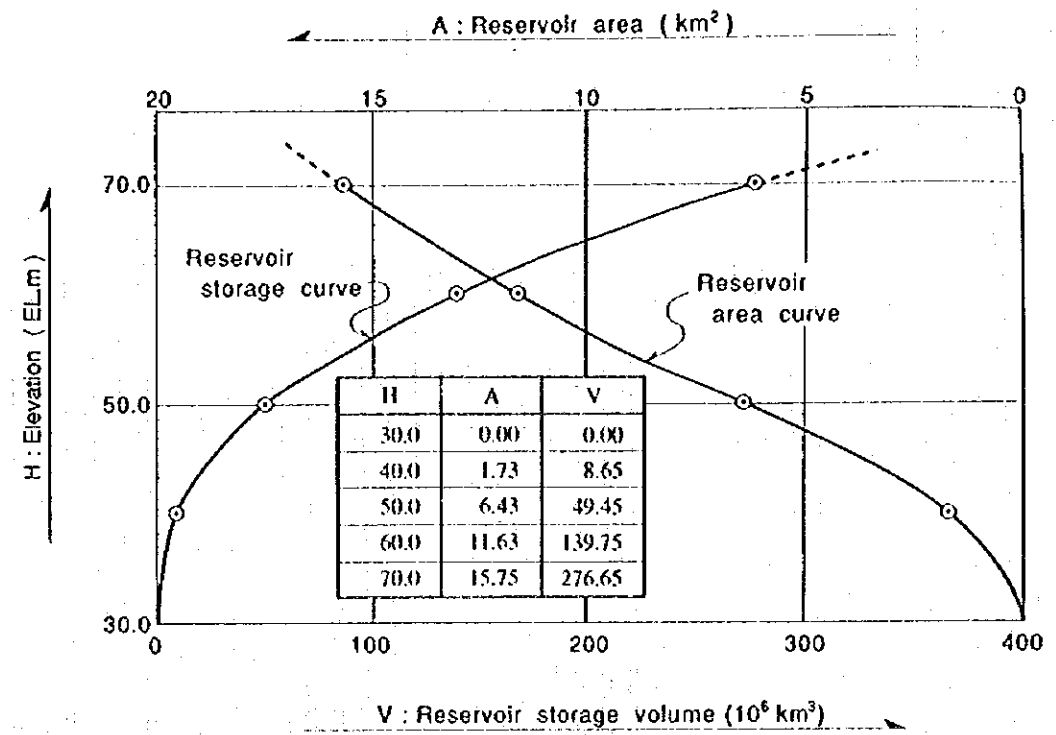
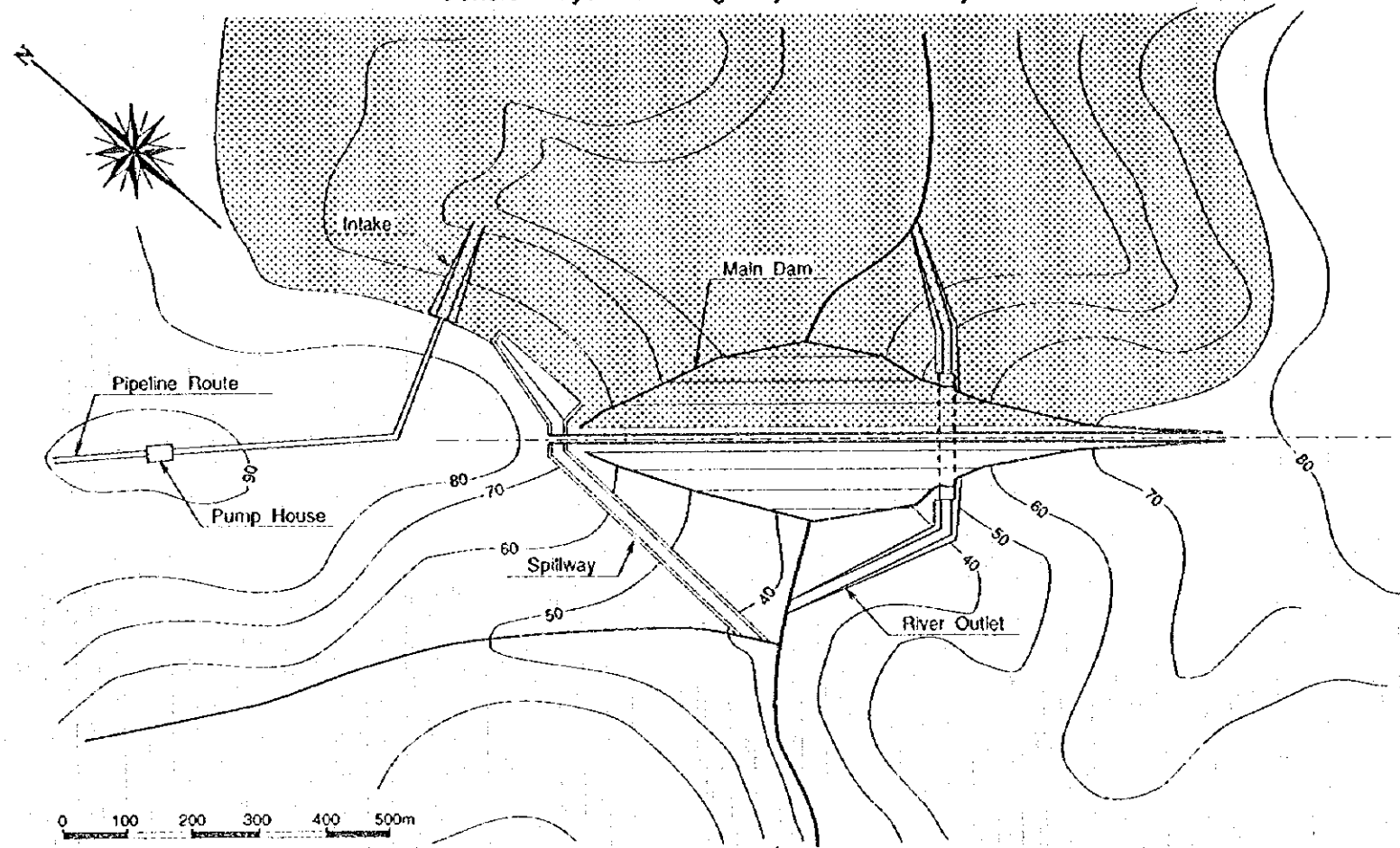
Upstream Elevation of Main Dam



Typical Section of Main Dam

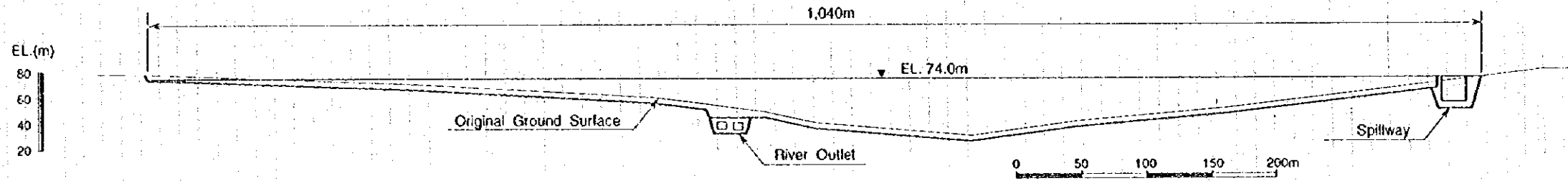


General Layout of Song Ray Reservoir Project

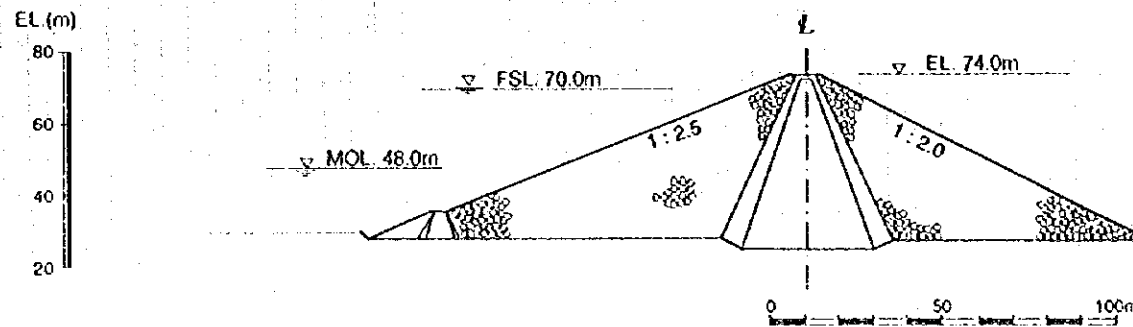


Reservoir Storage Volume Curve and Reservoir Area Curve

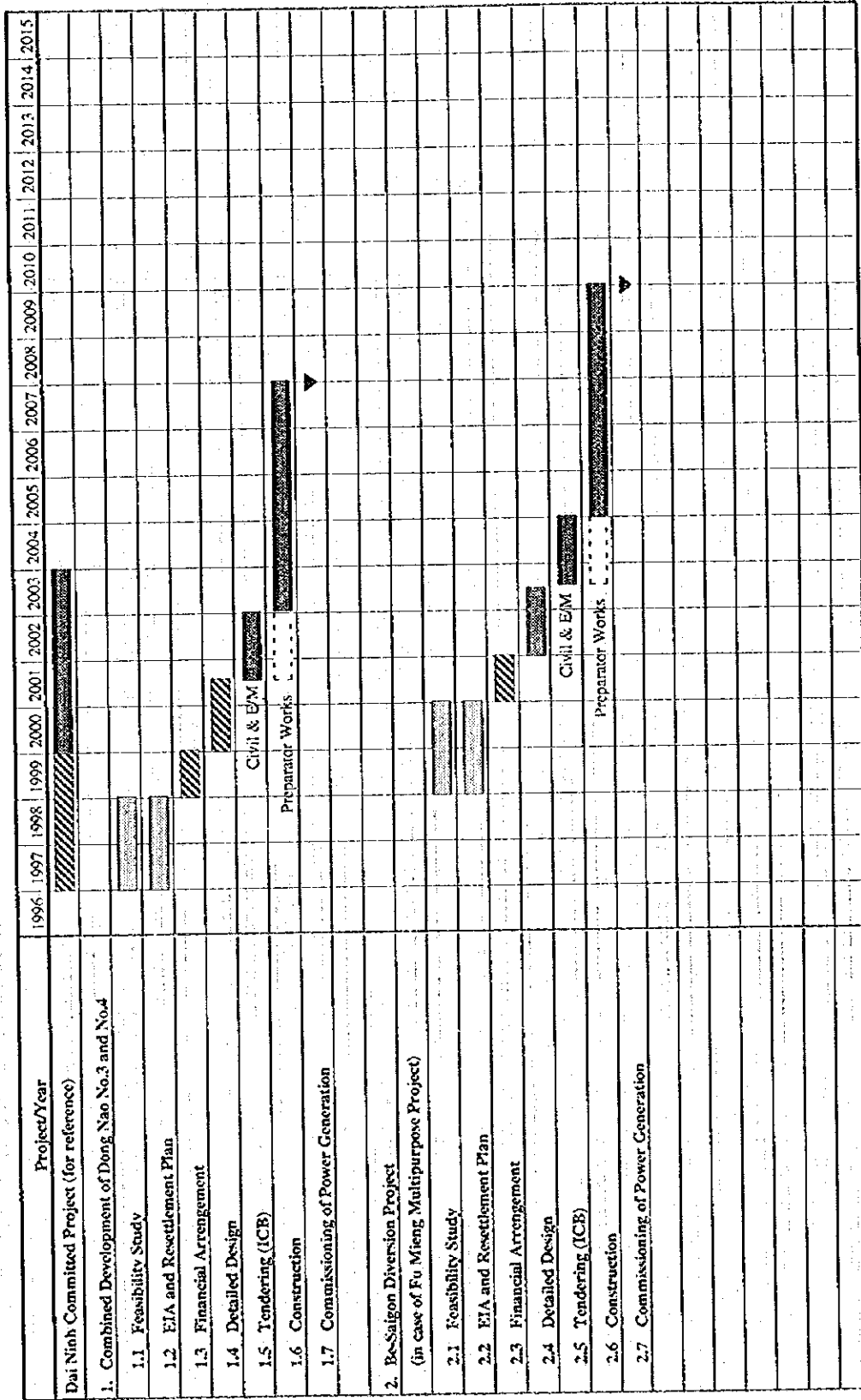
Upstream Elevation of Main Dam



Typical Section of Main Dam

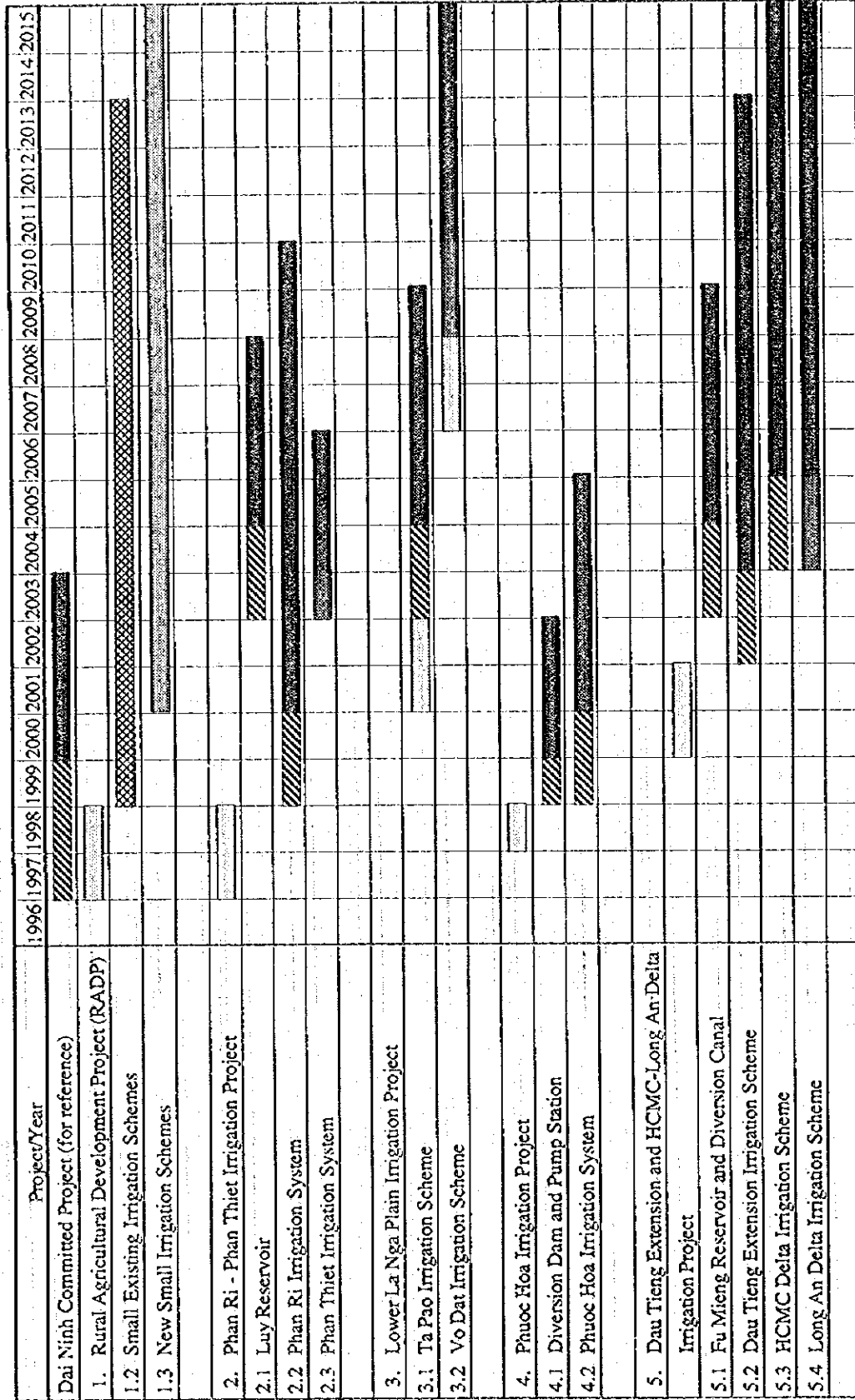






[White Box] : Master Plan Study/Feasibility Study/Investigation  
 [Diagonal Lines] : Detailed Design  
 [Horizontal Lines] : Construction

**Figure 10.1**  
**Implementation Sequence of Master Plan**  
**Projects for the Hydropower Sector**



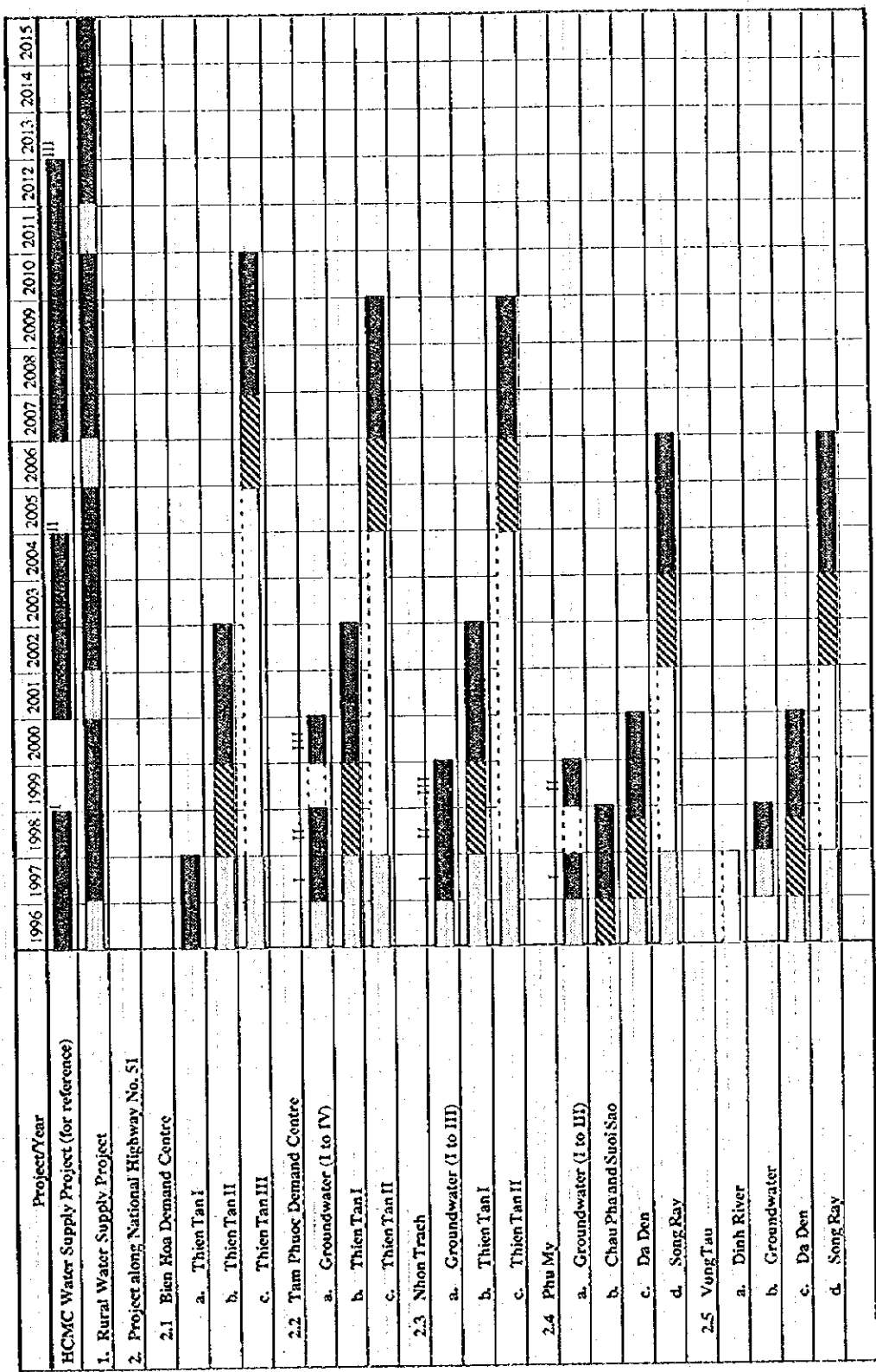
: Master Plan Study/Feasibility Study  
 : Design  
 : Construction  
 : Construction in parallel with Design

SOCIALIST REPUBLIC OF VIET NAM  
 MASTER PLAN STUDY ON DONG NAI RIVER  
 AND SURROUNDING BASINS  
 WATER RESOURCES DEVELOPMENT

JAPAN INTERNATIONAL COOPERATION AGENCY

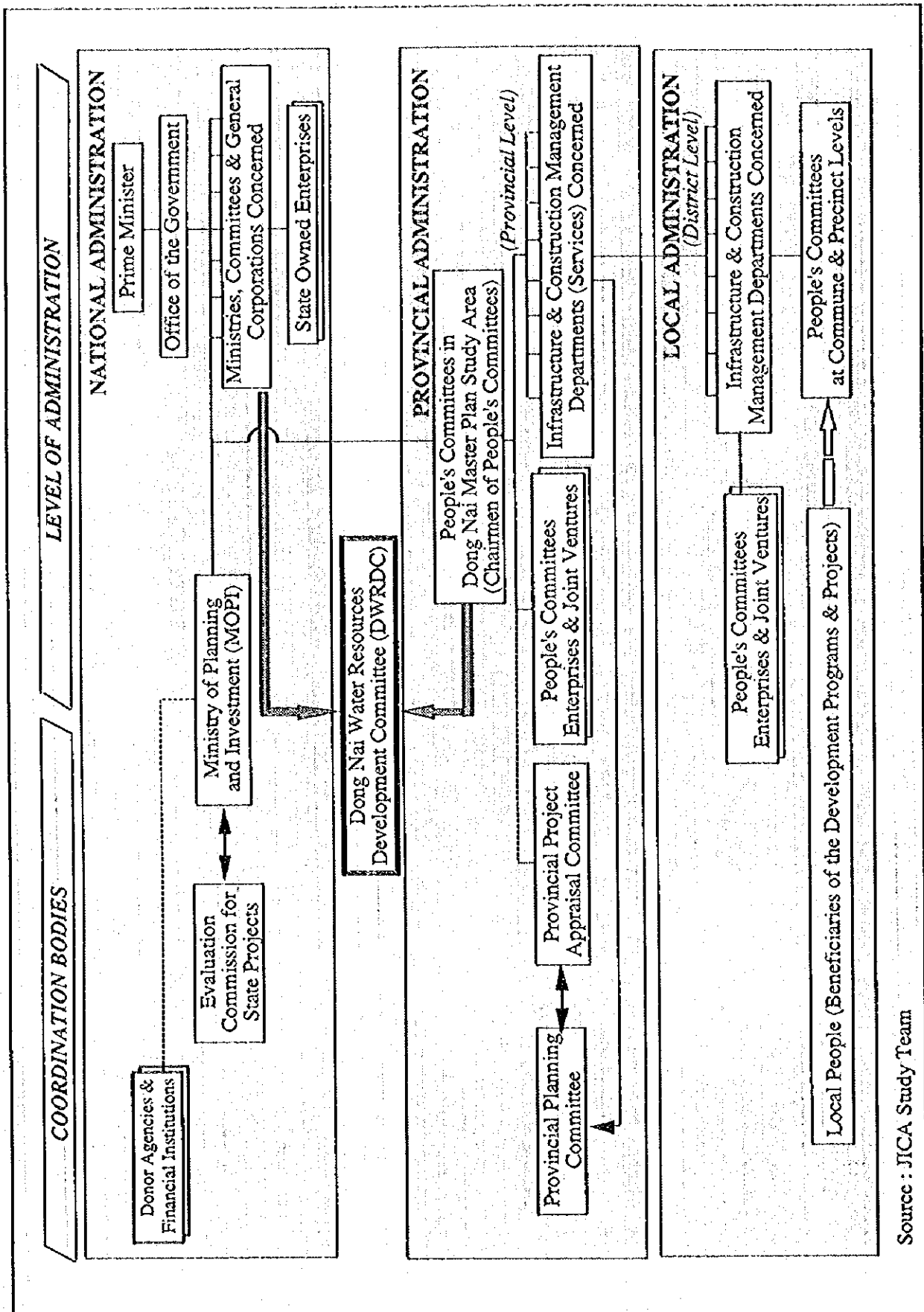
Figure 10.2

Implementation Sequence of Master Plan Projects for the Irrigation Sector



: Master Plan Study/Feasibility Study/Investigation  
 : Detailed Design  
 : Construction

**Figure 10.3**  
**Implementation Sequence of Master Plan**  
**Projects of the Water Supply Sector**



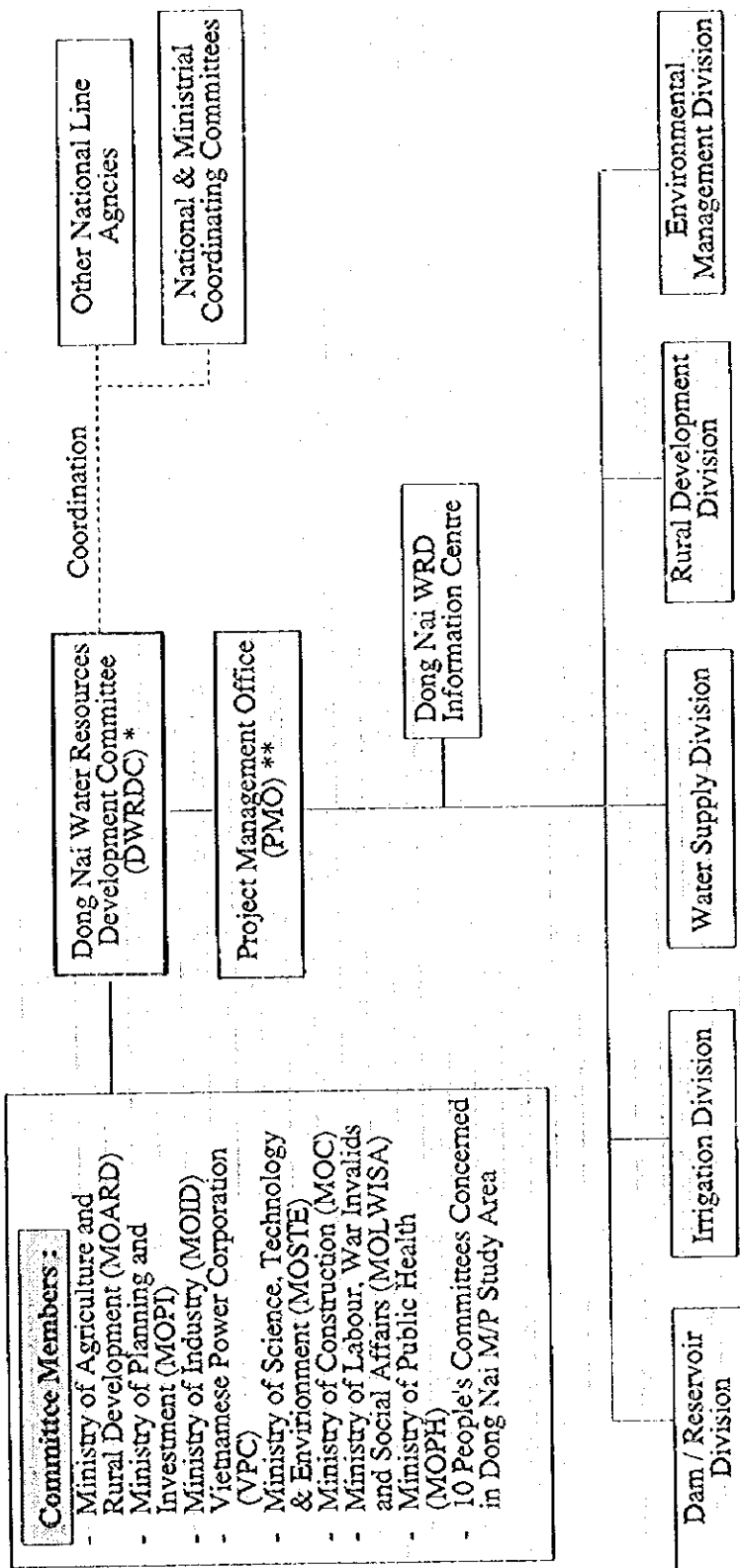
Source : JICA Study Team

SOCIALIST REPUBLIC OF VIET NAM  
 MASTER PLAN STUDY ON DONG NAI RIVER  
 AND SURROUNDING BASINS  
 WATER RESOURCES DEVELOPMENT

JAPAN INTERNATIONAL COOPERATION AGENCY

Figure 10.4

Proposed Structure for Implementing the Dong Nai  
 Water Resources Development Projects



Legend : — Direct Supervision or Relationship  
 - - - - - Cooperative or Coordinative Linkage

Notes : \* DWRDC consists of 18 members from the government agencies, corporation and people's committees concerned. The Council is headed by a representative of the MOARD.

\*\* Project Management Office (PMO) consists mainly of representatives of MOARD, MOPI, MOI, MOID, VPC, MOC and other development agencies.

Source : JICA Study Team

SOCIALIST REPUBLIC OF VIET NAM  
 MASTER PLAN STUDY ON DONG NAI RIVER  
 AND SURROUNDING BASINS  
 WATER RESOURCES DEVELOPMENT

JAPAN INTERNATIONAL COOPERATION AGENCY

Figure 10.5  
 Structure of Project Management System  
 for the Dong Nai WRD Projects