

CHAPTER 4

DATA COLLECTED AND RESULTS OF DEMAND FORECAST

Telephone Density and GDP/Capita in 1992

No.	Country	Population (millions)	GDP (millions)	GDP/Capita (US\$)	Main Line (1000 lines)	Waiting List (1000 lines)	Teledensity (DEL's /100persons)	Demand Density (DEL's + Waiters /100persons)
1	Algeria	26.3	35,674	1,356	962.3	756.9	3.66	6.54
2	Argentina	33.1	228,779	6,912	3,759.2	373.7	11.36	12.49
3	Australia	17.5	294,760	16,843	8,257.0	4.3	47.18	47.21
4	Bangladesh	114.1	23,783	208	256.3	121.5	0.22	0.33
5	Belgium	10.0	218,836	21,884	4,264.3	6.7	42.64	42.71
6	Brazil	153.9	360,495	2,342	10,670.1	510.3	6.93	7.26
7	Cameroon	12.2	10,397	852	52.0	9.0	0.43	0.50
8	Canada	27.4	493,602	18,015	16,246.6	0.0	59.29	59.29
9	Chile	13.6	41,203	3,030	1,213.2	313.7	8.92	11.23
10	China	1,162.2	506,075	435	11,469.1	1,620.4	0.99	1.13
11	Colombia	33.4	48,583	1,455	2,821.7	650.0	8.45	10.39
12	Cote D'Ivoire	12.9	8,726	676	86.1	36.2	0.67	0.95
13	Czech Republic	10.3	26,187	2,542	1,818.6	490.3	17.66	22.42
14	Ecuador	11.0	12,681	1,153	531.3	95.6	4.83	5.70
15	Egypt	54.7	33,553	613	2,173.6	1,267.5	3.97	6.29
16	France	57.4	1,319,883	22,994	29,905.3	1,267.5	52.10	54.31
17	Germany	80.6	1,789,261	22,199	35,420.8	1,200.0	43.95	45.44
18	Ghana	15.8	6,884	436	47.8	9.7	0.30	0.36
19	Greece	10.3	67,278	6,532	4,496.5	658.6	43.66	50.05
20	Hungary	10.3	35,218	3,419	1,291.1	753.0	12.53	19.85
21	India	883.6	214,598	243	6,796.7	2,845.9	0.77	1.09
22	Indonesia	184.3	126,364	686	1,485.3	225.7	0.81	0.93
23	Iran	59.6	110,258	1,850	2,997.9	508.0	5.03	5.88
24	Italy	57.8	1,222,962	21,159	23,709.0	45.0	41.02	41.10
25	Japan	124.5	3,670,979	29,486	57,652.3	0.0	46.31	46.31
26	Kenya	25.7	6,884	268	207.4	88.0	0.81	1.15
27	Korea(Rep. of)	43.7	296,136	6,777	15,865.1	0.0	36.30	36.30
28	Madagascar	12.4	2,767	223	36.6	3.4	0.30	0.32
29	Malaysia	18.6	57,568	3,093	2,091.6	168.7	11.25	12.15
30	Mexico	85.0	329,011	3,871	6,753.7	662.5	7.95	8.72
31	Morocco	26.2	28,401	1,084	653.9	134.6	2.50	3.01
32	Netherlands	15.2	320,290	21,072	7,395.0	20.0	48.65	48.78
33	Nigeria	101.9	29,667	291	320.9	243.1	0.31	0.55
34	Pakistan	119.3	41,904	351	1,243.6	743.4	1.04	1.67
35	Peru	22.4	22,100	987	613.7	346.2	2.74	4.29
36	Philippines	64.3	52,462	816	660.6	789.3	1.03	2.25
37	Poland	38.4	83,823	2,183	3,945.0	2,422.0	10.27	16.58
38	Romania	22.7	24,438	1,077	2,574.1	1,026.9	11.34	15.86
39	Saudi Arabia	16.8	111,343	6,628	1,568.4	399.9	9.34	11.72
40	South Africa	39.8	103,651	2,604	3,524.1	120.4	8.85	9.16
41	Spain	39.1	574,844	14,702	13,792.2	74.0	35.27	35.46
42	Sri Lanka	17.4	8,769	504	135.5	96.2	0.78	1.33
43	Syria	13.0	17,236	1,326	513.4	1,720.0	3.95	17.18
44	Thailand	58.0	110,337	1,902	1,790.0	1,591.8	3.09	5.83
45	Turkey	58.5	99,696	1,704	9,471.9	1,203.9	16.19	18.25
46	United Kingdom	57.8	903,126	15,625	26,084.0	0.0	45.13	45.13
47	United States	255.4	5,920,199	23,180	144,056.7	0.0	56.40	56.40
48	Venezuela	20.2	61,137	3,027	1,804.3	562.3	8.93	11.72
49	Yemen Rep.	13.0	9,615	740	143.4	98.0	1.10	1.86
50	Zimbabwe	10.4	5,035	484	127.1	88.8	1.22	2.08

Basic Data Source World Development Report 1994 (World Bank), published by the World Bank (Population & GDP at 1992)

ITU Statistical Yearbook 1994, "Chronological Series 1985 - 1992", published by ITU

(Main Lines and Waiting Lines at 1992)

World Mobile Telephone Service in 1993

	Country	Population	Subscribers	Mobile Telephone	Subscribers Sub./100Pop.	Mobile Sub./1000Pop.
1	Algeria	26.7	1,068,090	4,781	4.00	0.18
2	Burundi	6.0	15,550	320	0.26	0.05
3	Egypt	56.4	2,374,790	7,550	4.21	0.13
4	Gabon	1.0	29,830	1,200	2.98	1.20
5	Gambia	1.0	16,270	379	1.63	0.38
6	Ghana	16.4	48,680	1,742	0.30	0.11
7	Guinea-Bissau	1.0	8,560	21	0.86	0.02
8	Kenya	25.3	214,760	1,162	0.85	0.05
9	Morocco	25.9	820,800	6,725	3.17	0.26
10	Mauritius	1.1	106,930	4,037	9.72	3.67
11	Nigeria	105.3	342,290	9,019	0.33	0.09
12	South Africa	39.7	3,659,860	40,000	9.22	1.01
13	Tunisia	8.7	421,360	2,269	4.84	0.26
14	Canada	28.8	16,470,880	1,326,390	57.19	45.06
15	U.S.A.	257.8	143,084,380	16,009,461	57.44	62.10
16	Mexico	90.0	7,620,880	355,341	8.47	4.28
17	Argentina	33.8	4,114,550	125,780	12.17	3.72
18	Bolivia	7.1	234,360	3,670	3.30	0.52
19	Brazil	156.5	10,686,570	180,215	6.83	1.15
20	Chile	13.8	1,520,290	85,186	11.02	6.17
21	Costa Rica	3.3	364,120	4,533	11.03	1.37
22	Dominican Rep.	7.5	552,400	11,020	7.37	1.47
23	El Salvador	5.5	173,500	1,632	3.15	0.30
24	Ecuador	11.0	598,290	9,000	5.44	0.82
25	Guatemala	10.0	148,500	2,950	1.49	0.30
26	Jamaica	2.4	225,200	18,635	9.38	7.76
27	Paraguay	4.7	144,850	1,500	3.08	0.32
28	Peru	22.9	670,440	36,900	2.93	1.61
29	Puerto Rico	3.6	1,207,230	68,410	33.53	19.00
30	Trinidad and T	1.3	192,490	1,679	14.81	1.29
31	Uruguay	3.1	530,000	4,069	17.10	1.31
32	Venezuela	20.9	2,082,850	182,600	9.97	8.74
33	Saudi Arabia	17.4	1,574,940	15,910	9.05	0.91
34	Australia	17.6	8,540,000	760,000	48.52	43.18
35	China	1,178.4	14,074,000	638,000	1.19	0.54
36	Korea	44.1	16,686,060	471,784	37.84	10.70
37	U.A.E.	1.8	553,210	70,590	30.73	39.22
38	Indonesia	187.2	1,713,010	53,438	0.92	0.29
39	Israel	5.2	1,958,100	64,484	37.66	12.40
40	Japan	124.5	58,459,000	2,131,000	46.96	17.12
41	Jordan	4.1	288,110	1,462	7.03	0.36
42	Kuwait	1.8	357,900	60,100	19.88	33.39
43	Lao PDR	4.6	8,600	340	0.19	0.07
44	Malaysia	19.0	2,410,720	290,000	12.69	15.26
45	New Zealand	3.5	1,593,000	143,800	45.51	41.09
46	Oman	2.0	147,780	5,616	7.39	2.81
47	Pakistan	122.8	1,604,770	16,000	1.31	0.13
48	Philippines	64.8	847,540	101,738	1.31	1.57
49	Singapore	2.8	1,245,570	179,000	44.48	63.93
50	Sri Lanka	17.9	157,770	13,000	0.88	0.73
51	Thailand	58.1	2,184,890	436,000	3.76	7.50
52	Viet Nam	71.3	260,000	4,060	0.36	0.06
53	Germany	80.7	36,899,780	1,769,962	45.72	21.93
54	Austria	7.9	3,579,240	220,976	45.31	27.97
55	Belgium	10.0	4,395,700	66,929	43.96	6.69
56	Denmark	5.2	3,059,810	359,323	58.84	69.10
57	Spain	39.5	14,253,470	257,250	36.08	6.51
58	Estonia	1.6	358,300	7,224	22.39	4.52
59	Finland	5.1	2,760,660	489,174	54.13	95.92
60	France	57.5	30,900,000	430,000	53.74	7.48
61	Greece	10.4	4,744,020	17,000	45.62	1.63
62	Hungary	10.2	1,497,580	45,712	14.68	4.48
63	Ireland	3.5	1,170,000	61,100	33.43	17.46
64	Italy	57.1	24,176,000	1,207,000	42.34	21.14
65	Norway	4.3	2,334,840	375,000	54.30	87.21
66	Netherlands	15.3	7,630,000	216,000	49.87	14.12
67	Portugal	9.8	3,260,320	101,231	33.27	10.33
68	U.K.	57.9	26,642,000	1,171,047	46.01	20.23
69	Sweden	8.7	5,920,000	774,500	68.05	89.02
70	Switzerland	7.1	4,265,820	249,227	60.08	35.10

Source : World Development Report 1995 (World Bank)

Source : IJU Statistical Yearbook 1995

World Radio Paging Service

No.	Country	Population	Telephone Subscribers	Paging Telephone	Subscribers Sub./100Pop.	Paging Sub./1000Pop.
1	Burundi	6.0	15,550	64	0.26	0.01
2	Egypt	56.4	2,374,790	5,700	4.21	0.10
3	Kenya	25.3	214,760	647	0.85	0.03
4	Mexico	90.0	7,620,880	110,000	8.47	1.22
5	Chile	13.8	1,520,290	21,502	11.02	1.56
6	Dominican Rep.	7.5	552,400	7,031	7.37	0.94
7	Peru	22.9	670,440	2,780	2.93	0.12
8	Saudi Arabia	17.4	1,574,940	66,763	9.05	3.84
9	Indonesia	187.2	1,713,010	80,000	0.92	0.43
10	Kuwait	1.8	357,900	98,050	19.88	54.47
11	Malaysia	19.0	2,410,720	109,500	12.69	5.76
12	Oman	2.0	147,780	21,856	7.39	10.95
13	Pakistan	122.8	1,604,770	5,000	1.31	0.04
14	Philippine	64.8	847,540	134,160	1.31	2.07
15	Sri Lanka	17.9	157,770	4,230	0.88	0.24
16	Thailand	58.1	2,184,890	251,535	3.76	4.55

Source : World Development Report 1995 (World Bank)
 : ITU Statistical Yearbook 1995

No. of Horoo		Subbaatar District		Telephone in 1993						New Site Name	Old Site Name	Remarks
		Population	Household	Admi. & Business	Resident	Waiter	R + W	Demand				
1	2,867	745	568	331	181	512	1,080	ATC-3	ATC-3			
2	3,798	967	55	350	328	678	733	ATC-3	ATC-3			
3	6,483	1,622	153	527	583	1,110	1,263	ATC-3	ATC-3			
4	3,981	8,202	38	568	60	628	666	ATC-3	ATC-3			
5	4,253	1,103	147	335	186	521	668	ATC-36	ATC-6			
6	3,884	973	169	386	27	413	582	ATC-3	ATC-3			
7	6,404	1,546	124	719	388	1,107	1,231	ATC-3	ATC-3			
8	11,171	1,895	662	85	612	697	1,359	ATC-3	ATC-3			
9	3,230	675	0	8	72	80	80	ATC-73	ATC-7	Ger		
10	6,031	1,394	59	86	20	106	165	ATC-73	ATC-7	Ger		
11	3,602	658	92	83	100	183	275	ATC-73	ATC-7	Ger		
12	4,294	1,057	2	5	34	39	41	ATC-73	ATC-7	Ger		
13	2,167	612	0	5	80	85	85	ATC-73	ATC-7	Ger		
14	3,119	785	6	5	100	105	111	ATC-73	ATC-7	Ger		
15	5,901	1,565	3	62	213	275	278	ATC-73	ATC-7	Ger (Summer camp)		
16	2,448	630	13	3	82	85	98	ATC-73	ATC-7	Ger		
Total	73,633	24,409	2,091	3,558	3,066	6,624	8,715					

Subbaatar District : Business Demand																
No. of Horco	1995	1996	1997	1998	1999	2000	2001	2002	2003	2004	2005	2006	2007	2008	2009	2010
1	837	882	929	981	1,038	1,100	1,166	1,235	1,310	1,389	1,472	1,561	1,654	1,753	1,858	1,970
2	81	85	90	95	100	106	113	120	127	134	143	151	160	170	180	191
3	225	237	250	264	279	296	314	333	353	374	396	420	445	472	500	531
4	56	59	62	66	69	74	78	83	88	93	98	104	111	117	124	132
5	217	228	241	254	269	285	302	320	339	359	381	404	428	454	481	510
6	249	262	277	292	309	327	347	368	390	413	438	464	492	521	553	586
7	183	192	203	214	227	240	254	270	286	303	321	341	361	383	406	430
8	975	1,027	1,083	1,143	1,209	1,282	1,359	1,440	1,526	1,619	1,715	1,819	1,928	2,043	2,165	2,295
9	0	0	0	0	0	0	0	0	0	0	0	0	0	0	0	0
10	87	92	97	102	108	114	121	128	136	144	153	162	172	182	193	205
11	136	143	151	159	168	178	189	200	212	225	238	253	268	284	301	319
12	3	3	3	3	4	4	4	4	5	5	5	5	6	6	7	7
13	0	0	0	0	0	0	0	0	0	0	0	0	0	0	0	0
14	9	9	10	10	11	12	12	13	14	15	16	16	17	19	20	21
15	4	5	5	5	5	6	6	7	7	7	8	8	9	9	10	10
16	19	20	21	22	24	25	27	28	30	32	34	36	38	40	43	45
Total	3,081	3,244	3,422	3,610	3,820	4,049	4,292	4,549	4,823	5,112	5,418	5,744	6,089	6,453	6,841	7,252

Subsatar District : Residential Demand																
No. of Horoo	1995	1996	1997	1998	1999	2000	2001	2002	2003	2004	2005	2006	2007	2008	2009	2010
1	673	723	755	807	853	905	962	1,026	1,087	1,156	1,218	1,289	1,364	1,444	1,525	1,579
2	892	957	1,000	1,069	1,130	1,198	1,273	1,359	1,440	1,530	1,614	1,707	1,806	1,912	2,020	2,091
3	1,460	1,568	1,637	1,751	1,849	1,961	2,085	2,225	2,357	2,505	2,642	2,795	2,958	3,131	3,307	3,423
4	826	887	926	990	1,046	1,109	1,179	1,259	1,333	1,418	1,495	1,582	1,673	1,771	1,871	1,936
5	685	736	768	822	868	920	979	1,045	1,106	1,176	1,240	1,312	1,388	1,470	1,552	1,607
6	543	583	609	651	688	730	776	828	877	932	983	1,040	1,100	1,165	1,230	1,274
7	1,456	1,563	1,632	1,746	1,844	1,956	2,079	2,219	2,350	2,499	2,634	2,788	2,950	3,123	3,298	3,414
8	916	984	1,028	1,099	1,161	1,231	1,309	1,397	1,480	1,573	1,659	1,755	1,857	1,966	2,077	2,149
9	105	113	118	126	133	141	150	160	170	181	190	201	213	226	238	247
10	139	150	156	167	177	187	199	213	225	239	252	267	282	299	316	327
11	241	258	270	289	305	323	344	367	389	413	436	461	488	516	545	564
12	51	55	58	62	65	69	73	78	83	88	93	98	104	110	116	120
13	112	120	125	134	142	150	160	170	180	192	202	214	226	240	253	262
14	138	148	155	166	175	186	197	211	223	237	250	264	280	296	313	324
15	362	388	406	434	458	486	516	551	584	621	654	693	733	776	819	848
16	112	120	125	134	142	150	160	170	180	192	202	214	226	240	253	262
Total	8,711	9,353	9,768	10,447	11,036	11,702	12,441	13,278	14,064	14,952	15,764	16,680	17,648	18,685	19,733	20,427

Subbaatar District : Business + Residential Demand																
No. of Horoo	1995	1996	1997	1998	1999	2000	2001	2002	2003	2004	2005	2006	2007	2008	2009	2010
1	1,510	1,605	1,684	1,788	1,891	2,005	2,128	2,261	2,397	2,545	2,690	2,850	3,018	3,197	3,383	3,549
2	973	1,042	1,090	1,164	1,230	1,304	1,386	1,479	1,567	1,664	1,757	1,858	1,966	2,082	2,200	2,282
3	1,685	1,805	1,887	2,015	2,128	2,257	2,399	2,558	2,710	2,879	3,038	3,215	3,403	3,603	3,807	3,954
4	882	946	988	1,056	1,115	1,183	1,257	1,342	1,421	1,511	1,593	1,686	1,784	1,888	1,995	2,068
5	902	964	1,009	1,076	1,137	1,205	1,281	1,365	1,445	1,535	1,621	1,716	1,816	1,924	2,033	2,117
6	792	845	886	943	997	1,057	1,123	1,196	1,267	1,345	1,421	1,504	1,592	1,686	1,783	1,860
7	1,639	1,755	1,835	1,960	2,071	2,196	2,333	2,489	2,636	2,802	2,955	3,129	3,311	3,506	3,704	3,844
8	1,891	2,011	2,111	2,242	2,370	2,513	2,668	2,837	3,006	3,192	3,374	3,574	3,785	4,009	4,242	4,444
9	105	113	118	126	133	141	150	160	170	181	190	201	213	226	238	247
10	226	242	253	269	285	301	320	341	361	383	405	429	454	481	509	532
11	377	401	421	448	473	501	533	567	601	638	674	714	756	800	846	883
12	54	58	61	65	69	73	77	82	88	93	98	103	110	116	123	127
13	112	120	125	134	142	150	160	170	180	192	202	214	226	240	253	262
14	147	157	165	176	186	198	209	224	237	252	266	280	297	315	333	345
15	366	393	411	439	463	492	522	558	591	628	662	701	742	785	829	858
16	131	140	146	156	166	175	187	198	210	224	236	250	264	280	296	307
Total	11,792	12,597	13,190	14,057	14,856	15,751	16,733	17,827	18,887	20,064	21,182	22,424	23,737	25,138	26,574	27,679

Chingeltei District		in 1993										Remarks
No. of Horoo	Population	Household	Telephone				R + W	Demand	Old Site Name	New Site Name		
			Admi. & Business	Resident	Waiter							
1	3,312	881	568	500	129	629	1,197	ATC-3	ATC-3			
2	3,551	990	388	361	120	481	869	ATC-36	ATC-6			
3	4,146	1,259	96	545	173	718	814	ATC-3	ATC-3			
4	6,312	1,357	932	395	50	445	1,377	ATC-3	ATC-3			
5	4,965	1,222	105	260	303	563	668	ATC-3	ATC-3			
6	3,825	891	191	261	86	347	538	ATC-3	ATC-3			
7	3,434	804	1	50	125	175	176	ATC-36	ATC-6		Ger	
8	2,953	703	1	40	117	157	158	ATC-36	ATC-6		Ger	
9	3,908	922	10	2	137	139	149	ATC-73	ATC-7		Ger	
10	5,445	1,022	9	8	51	59	68	ATC-73	ATC-7		Ger	
11	2,905	680	20	8	87	95	115	ATC-73	ATC-7		Ger	
12	6,143	1,421	5	0	252	252	257	ATC-73	ATC-7		Ger	
13	4,859	988	4	0	136	136	140	ATC-73	ATC-7		Ger	
14	3,804	864	3	12	136	148	151	ATC-73	ATC-7		Ger	
15	5,059	1,268	3	10	323	333	336	ATC-73	ATC-7		Ger	
16	6,788	1,385	1	5	112	117	118	ATC-73	ATC-7		Ger	
17	5,070	1,480	1	5	316	321	322	ATC-73	ATC-7		Ger	
18	5,191	1,321	1	2	287	289	290	ATC-73	ATC-7		Ger	
Total	81,650	19,458	2,339	2,464	2,940	5,404	7,743					

Chingeltei District : Business Demand																
No. of Horoo	1995	1996	1997	1998	1999	2000	2001	2002	2003	2004	2005	2006	2007	2008	2009	2010
1	980	1,033	1,090	1,150	1,217	1,290	1,367	1,448	1,535	1,628	1,726	1,830	1,940	2,055	2,178	2,310
2	670	706	744	786	831	881	934	989	1,049	1,112	1,179	1,250	1,325	1,404	1,488	1,578
3	166	175	184	194	206	218	231	245	260	275	292	309	328	347	368	390
4	1,609	1,696	1,788	1,887	1,997	2,117	2,244	2,376	2,520	2,671	2,833	3,002	3,182	3,372	3,574	3,790
5	181	191	201	213	225	238	253	268	284	301	319	338	359	380	403	427
6	330	347	366	387	409	434	460	487	516	547	580	615	652	691	732	777
7	2	2	2	2	2	2	2	3	3	3	3	3	3	4	4	4
8	2	2	2	2	2	2	2	3	3	3	3	3	3	4	4	4
9	17	18	19	20	21	23	24	25	27	29	30	32	34	36	38	41
10	16	16	17	18	19	20	22	23	24	26	27	29	31	33	35	37
11	35	36	38	40	43	45	48	51	54	57	61	64	68	72	77	81
12	9	9	10	10	11	11	12	13	14	14	15	16	17	18	19	20
13	7	7	8	8	9	9	10	10	11	11	12	13	14	14	15	16
14	5	5	6	6	6	7	7	8	8	9	9	10	10	11	12	12
15	5	5	6	6	6	7	7	8	8	9	9	10	10	11	12	12
16	2	2	2	2	2	2	2	3	3	3	3	3	3	4	4	4
17	2	2	2	2	2	2	2	3	3	3	3	3	3	4	4	4
18	2	2	2	2	2	2	2	3	3	3	3	3	3	4	4	4
Total	4,040	4,254	4,487	4,735	5,010	5,310	5,629	5,966	6,325	6,704	7,107	7,533	7,985	8,464	8,971	9,511

Chingeltei District : Residential Demand																
No. of Horoo	1995	1996	1997	1998	1999	2000	2001	2002	2003	2004	2005	2006	2007	2008	2009	2010
1	844	901	968	1,016	1,084	1,128	1,210	1,269	1,357	1,455	1,508	1,610	1,718	1,790	1,906	2,019
2	646	689	740	777	828	863	925	971	1,037	1,112	1,154	1,231	1,313	1,369	1,457	1,544
3	964	1,029	1,105	1,160	1,237	1,288	1,381	1,449	1,549	1,661	1,722	1,837	1,961	2,043	2,175	2,304
4	597	637	685	719	766	798	856	898	960	1,029	1,067	1,139	1,215	1,266	1,348	1,428
5	756	807	866	909	970	1,010	1,083	1,136	1,214	1,302	1,350	1,441	1,537	1,602	1,706	1,807
6	466	497	534	560	598	622	668	700	748	803	832	888	947	988	1,051	1,114
7	235	251	269	283	301	314	337	353	377	405	420	448	478	498	530	562
8	211	225	242	254	270	282	302	317	339	363	377	402	429	447	476	504
9	187	199	214	225	239	249	267	280	300	321	333	356	380	396	421	446
10	79	85	91	95	102	106	113	119	127	136	141	151	161	168	179	189
11	128	136	146	153	164	170	183	192	205	220	228	243	259	270	288	305
12	338	361	388	407	434	452	485	509	544	583	604	645	688	717	764	809
13	183	195	209	220	234	244	262	274	293	315	326	348	371	387	412	436
14	199	212	228	239	255	265	285	299	319	342	355	379	404	421	448	475
15	447	477	515	538	573	597	641	672	718	770	799	852	909	948	1,009	1,069
16	157	168	180	189	201	210	225	236	252	271	281	299	319	333	354	375
17	431	460	494	519	553	576	618	648	692	742	770	822	876	914	973	1,030
18	388	414	445	467	498	518	556	583	623	668	693	740	789	822	876	928
Total	7,256	7,743	8,317	8,730	9,307	9,692	10,397	10,905	11,654	12,498	12,960	13,831	14,754	15,379	16,373	17,344

Chingeltei District : Business + Residential Demand																
No. of Horoo	1995	1996	1997	1998	1999	2000	2001	2002	2003	2004	2005	2006	2007	2008	2009	2010
1	1,824	1,934	2,058	2,166	2,301	2,418	2,577	2,717	2,892	3,083	3,234	3,440	3,658	3,845	4,084	4,329
2	1,316	1,395	1,484	1,563	1,659	1,744	1,859	1,960	2,086	2,224	2,333	2,481	2,658	2,773	2,945	3,122
3	1,130	1,204	1,289	1,354	1,443	1,506	1,612	1,694	1,809	1,936	2,014	2,146	2,289	2,390	2,543	2,694
4	2,206	2,333	2,473	2,606	2,763	2,915	3,100	3,274	3,480	3,700	3,900	4,141	4,397	4,638	4,922	5,218
5	937	998	1,067	1,122	1,195	1,248	1,336	1,404	1,498	1,603	1,669	1,779	1,896	1,982	2,109	2,234
6	796	844	900	947	1,007	1,056	1,128	1,187	1,264	1,350	1,412	1,503	1,599	1,679	1,783	1,891
7	237	253	271	285	303	316	339	356	380	408	423	451	481	502	534	566
8	213	227	244	256	272	284	304	320	342	366	380	405	432	451	480	508
9	204	217	233	245	260	272	291	305	327	350	363	388	414	432	459	487
10	95	101	108	113	121	126	135	142	151	162	168	180	192	201	214	226
11	163	172	184	193	207	215	231	243	259	277	289	307	327	342	365	386
12	347	370	398	417	445	463	497	522	558	597	619	661	705	735	783	829
13	190	202	217	228	243	253	272	284	304	326	338	361	385	401	427	452
14	204	217	234	245	261	272	292	307	327	351	364	389	414	432	460	487
15	452	482	519	544	579	604	648	680	726	779	808	862	919	959	1,021	1,081
16	159	170	182	191	203	212	227	239	255	274	284	302	322	337	358	379
17	433	462	496	521	555	578	620	651	695	745	773	825	879	918	977	1,034
18	390	416	447	469	500	520	558	586	626	671	696	743	792	826	880	932
Total	11,296	11,997	12,804	13,465	14,317	15,002	16,026	16,871	17,979	19,202	20,067	21,364	22,739	23,843	25,344	26,853

No. of Horoo		Bayangol District										in 1993		New Site Name	Old Site Name	Remarks
		Population	Household	Telephone				R + W	Demand	New Site Name	Old Site Name					
				Admin. & Busi.	Resident	Waiter	Waiver									
1	7,541	1,763	71	121	100	221	292	ATC-6	ATC-36							
2	3,835	902	29	68	76	144	173	ATC-6	ATC-36							
3	7,508	1,686	130	0	0	0	130	ATC-6	ATC-36							
4	7,882	1,858	156	295	0	295	451	ATC-6	ATC-36							
5	8,040	1,670	232	549	735	1,284	1,516	ATC-2	ATC-33							
6	5,030	1,136	0	269	427	696	696	ATC-6	ATC-36							
7	5,335	1,348	17	459	448	907	924	ATC-2	ATC-33							
8	7,467	1,988	30	684	569	1,253	1,283	ATC-6	ATC-36							Ger / Apartment
9	4,744	1,142	0	20	163	183	183	ATC-2	ATC-33							Ger / Apartment
10	4,192	966	0	59	75	132	132	ATC-6	ATC-36							Ger
11	3,651	1,024	31	141	80	221	252	ATC-6	ATC-36							Ger
12	3,828	950	0	60	105	165	165	ATC-6	ATC-36							Ger
13	4,977	1,223	55	560	195	755	810	ATC-6	ATC-36							
14	5,384	1,365	50	644	331	975	1,025	ATC-6	ATC-36							
15	5,864	1,426	93	640	365	1,005	1,098	ATC-6	ATC-36							
16	4,195	1,030	25	30	71	101	126	ATC-6	ATC-36							Ger
17	4,859	1,175	65	318	341	659	724	ATC-6	ATC-36							Ger / Apartment
18	6,685	1,473	53	695	589	1,284	1,337	ATC-6	ATC-36							
19	6,239	1,959	31	604	502	1,106	1,137	ATC-6	ATC-36							
Total	107,056	26,082	1,068	6,216	5,170	11,386	12,454									

Bayangol District : Business Demand																
No. of Horoo	1995	1996	1997	1998	1999	2000	2001	2002	2003	2004	2005	2006	2007	2008	2009	2010
1	73	77	81	86	90	96	102	108	114	121	129	136	144	153	162	172
2	30	31	33	35	37	39	42	44	47	50	52	56	59	62	66	70
3	134	141	149	157	166	176	186	197	209	222	235	249	264	280	297	315
4	160	169	179	188	199	211	224	237	251	266	282	299	317	336	356	378
5	239	251	266	280	297	312	333	352	374	396	420	445	471	500	530	562
6	0	0	0	0	0	0	0	0	0	0	0	0	0	0	0	0
7	17	18	19	21	22	23	24	26	27	29	31	33	35	37	39	41
8	31	33	34	36	38	41	43	46	48	51	54	58	61	65	69	73
9	0	0	0	0	0	0	0	0	0	0	0	0	0	0	0	0
10	0	0	0	0	0	0	0	0	0	0	0	0	0	0	0	0
11	32	34	35	37	39	42	44	47	50	53	56	59	63	67	71	75
12	0	0	0	0	0	0	0	0	0	0	0	0	0	0	0	0
13	57	60	63	66	70	74	79	84	89	94	100	106	112	119	126	133
14	51	54	57	60	64	68	72	76	81	85	91	96	102	108	114	121
15	96	101	106	112	118	126	133	141	150	159	168	178	189	200	212	225
16	26	27	29	30	32	34	36	38	40	43	45	48	51	54	57	61
17	67	70	74	79	83	88	93	99	105	111	118	125	132	140	149	157
18	54	57	61	64	68	72	76	81	85	90	96	102	108	114	121	128
19	32	34	35	37	39	42	44	47	50	53	56	59	63	67	71	75
Total	1,099	1,157	1,221	1,288	1,362	1,444	1,531	1,623	1,720	1,823	1,933	2,049	2,171	2,302	2,440	2,586

Bayangol District : Residential Demand																
No. of Horoo	1995	1996	1997	1998	1999	2000	2001	2002	2003	2004	2005	2006	2007	2008	2009	2010
1	257	273	290	310	328	347	369	393	410	435	459	485	514	544	574	603
2	167	178	189	202	213	226	240	256	267	284	299	316	335	354	374	393
3	0	0	0	0	0	0	0	0	0	0	0	0	0	0	0	0
4	343	364	388	414	437	463	492	525	547	581	612	648	685	726	766	805
5	1,493	1,586	1,687	1,803	1,903	2,017	2,143	2,286	2,380	2,530	2,666	2,821	2,984	3,159	3,336	3,506
6	809	860	914	977	1,032	1,093	1,162	1,239	1,290	1,371	1,445	1,529	1,617	1,712	1,808	1,900
7	1,054	1,120	1,192	1,274	1,344	1,425	1,514	1,614	1,681	1,787	1,883	1,992	2,108	2,231	2,356	2,476
8	1,457	1,547	1,646	1,759	1,857	1,968	2,091	2,230	2,322	2,467	2,602	2,752	2,912	3,083	3,255	3,421
9	213	226	240	257	271	287	305	326	339	361	380	402	425	450	475	500
10	153	163	173	185	196	207	220	235	245	260	274	290	307	325	343	360
11	257	273	290	310	328	347	369	393	410	435	459	485	514	544	574	603
12	192	204	217	232	245	259	275	294	306	325	343	362	383	406	429	451
13	878	932	992	1,060	1,119	1,186	1,260	1,344	1,399	1,487	1,568	1,659	1,754	1,857	1,962	2,061
14	1,134	1,204	1,281	1,369	1,445	1,532	1,627	1,735	1,807	1,921	2,024	2,142	2,266	2,399	2,533	2,662
15	1,168	1,241	1,320	1,411	1,489	1,579	1,677	1,789	1,862	1,980	2,087	2,208	2,335	2,473	2,611	2,744
16	117	125	133	142	150	159	169	180	187	199	210	222	235	248	262	276
17	766	814	866	925	977	1,035	1,100	1,173	1,221	1,298	1,368	1,448	1,531	1,621	1,712	1,799
18	1,493	1,586	1,687	1,803	1,903	2,017	2,143	2,285	2,380	2,530	2,666	2,821	2,984	3,159	3,336	3,506
19	1,286	1,366	1,453	1,553	1,639	1,737	1,846	1,969	2,050	2,179	2,296	2,430	2,570	2,721	2,873	3,020
Total	13,237	14,062	14,958	15,986	16,876	17,884	19,002	20,266	21,103	22,430	23,641	25,012	26,459	28,012	29,579	31,086

Bayangol District : Business + Residential Demand																			
No. of Horoo	1995	1996	1997	1998	1999	2000	2001	2002	2003	2004	2005	2006	2007	2008	2009	2010			
1	330	350	371	396	418	443	471	501	524	556	588	621	658	697	736	775			
2	197	209	222	237	250	265	282	300	314	334	351	372	394	416	440	463			
3	134	141	149	157	166	176	186	197	209	222	235	249	264	280	297	315			
4	503	533	567	602	636	674	716	762	798	847	894	947	1,002	1,062	1,122	1,183			
5	1,732	1,837	1,953	2,083	2,200	2,329	2,476	2,638	2,754	2,926	3,086	3,266	3,455	3,659	3,866	4,068			
6	809	860	914	977	1,032	1,093	1,162	1,239	1,290	1,371	1,445	1,529	1,617	1,712	1,808	1,900			
7	1,071	1,138	1,211	1,295	1,366	1,448	1,538	1,640	1,708	1,816	1,914	2,025	2,143	2,268	2,395	2,517			
8	1,488	1,580	1,680	1,795	1,895	2,009	2,134	2,276	2,370	2,518	2,656	2,810	2,973	3,148	3,324	3,494			
9	213	226	240	257	271	287	305	326	339	361	380	402	425	450	475	500			
10	153	163	173	185	196	207	220	235	245	260	274	290	307	325	343	360			
11	289	307	325	347	367	389	413	440	460	488	515	544	577	611	645	678			
12	192	204	217	232	245	259	275	294	306	325	343	362	383	406	429	451			
13	935	992	1,055	1,126	1,189	1,260	1,339	1,428	1,488	1,581	1,668	1,765	1,866	1,976	2,088	2,194			
14	1,185	1,258	1,338	1,429	1,509	1,600	1,699	1,811	1,888	2,006	2,115	2,238	2,368	2,507	2,647	2,783			
15	1,264	1,342	1,426	1,523	1,607	1,705	1,810	1,930	2,012	2,139	2,255	2,386	2,524	2,673	2,823	2,969			
16	143	152	162	172	182	193	205	218	227	242	255	270	286	302	319	337			
17	833	884	940	1,004	1,060	1,123	1,193	1,272	1,326	1,409	1,486	1,573	1,663	1,761	1,861	1,956			
18	1,547	1,643	1,748	1,867	1,971	2,089	2,219	2,366	2,465	2,620	2,762	2,923	3,092	3,273	3,457	3,634			
19	1,318	1,400	1,488	1,590	1,678	1,779	1,890	2,016	2,100	2,232	2,352	2,489	2,633	2,788	2,944	3,095			
Total	14,336	15,219	16,179	17,274	18,238	19,328	20,533	21,889	22,823	24,253	25,374	27,061	28,630	30,314	32,019	33,672			

No. of Moroo		Songinohairhan District		in 1993				Old Site Name	New Site Name	Remarks
		Population	Household	Admin. & Busi.	Resident	Waiter	R + W			
1	4,006	838	25	20	97	117	142	ATC-33	ATC-2	Ger & (Inn. Children)
2	4,328	815	0	20	93	113	115	ATC-33	ATC-2	Ger
3	4,974	829	6	27	142	169	175	ATC-33	ATC-2	Ger
4	3,561	745	75	15	45	60	135	ATC-33	ATC-2	Ger / Apartment
5	4,548	935	84	5	66	71	155	ATC-33	ATC-2	Ger
6	5,598	1,215	0	10	17	27	27	ATC-33	ATC-2	
7	3,780	776	26	17	60	77	103	ATC-33	ATC-2	Ger
8	4,484	999	7	20	110	130	137	ATC-36	ATC-21	Ger
9	6,076	1,327	6	180	135	315	521	ATC-36	ATC-21	Ger
10	4,980	1,128	0	54	192	246	246	ATC-36	ATC-21	Ger
11	3,403	795	0	33	100	133	133	ATC-36	ATC-21	Ger
12	4,295	865	12	464	334	798	810	ATC-33	ATC-2	
13	7,845	1,625	11	538	433	971	982	ATC-33	ATC-2	
14	5,261	1,184	10	467	356	823	833	ATC-33	ATC-2	
15	6,649	1,409	4	1,067	440	1,507	1,511	ATC-33	ATC-2	
16	5,435	1,284	25	481	390	871	896	ATC-33	ATC-2	
17	6,350	1,575	5	558	356	914	919	ATC-33	ATC-2	
18	8,242	1,951	155	539	538	1,077	1,232	ATC-33	ATC-2	
19	5,875	1,298	36	145	315	460	496	ATC-33	ATC-2	Ger
20	6,400	1,300	5	20	0	20	25	JA	JA	Ingenier (Parton, Survey Data)
21	6,408	1,343	453	61	45	106	559	ATC-33	ATC-2	
Total	112,494	24,032	945	4,741	4,264	9,005	9,950			

Songinohairhan District : Business Demand																
No. of Heroc	1995	1996	1997	1998	1999	2000	2001	2002	2003	2004	2005	2006	2007	2008	2009	2010
1	40	42	44	47	50	53	56	59	63	66	70	75	79	84	89	94
2	0	0	0	0	0	0	0	0	0	0	0	0	0	0	0	0
3	10	10	11	11	12	13	13	14	15	16	17	18	19	20	21	23
4	120	127	133	141	149	158	167	177	188	199	211	224	237	252	267	283
5	134	142	150	158	167	177	187	199	210	223	237	251	266	282	299	317
6	0	0	0	0	0	0	0	0	0	0	0	0	0	0	0	0
7	42	44	46	49	52	55	58	61	65	69	73	78	82	87	92	98
8	11	12	12	13	14	15	16	17	18	19	20	21	22	23	25	26
9	10	10	11	11	12	13	13	14	15	16	17	18	19	20	21	23
10	0	0	0	0	0	0	0	0	0	0	0	0	0	0	0	0
11	0	0	0	0	0	0	0	0	0	0	0	0	0	0	0	0
12	19	20	21	23	24	25	27	28	30	32	34	36	38	40	43	45
13	18	19	20	21	22	23	25	26	28	29	31	33	35	37	39	41
14	16	17	18	19	20	21	22	24	25	27	28	30	32	34	36	38
15	6	7	7	8	8	8	9	9	10	11	11	12	13	13	14	15
16	40	42	44	47	50	53	56	59	63	66	70	75	79	84	89	94
17	8	8	9	9	10	11	11	12	13	13	14	15	16	17	18	19
18	248	261	276	291	307	326	346	367	388	412	437	462	490	520	551	584
19	58	61	64	68	71	76	80	85	90	96	101	107	114	121	128	136
20	8	8	9	9	10	11	11	12	13	13	14	15	16	17	18	19
21	725	764	806	849	898	952	1,011	1,072	1,135	1,204	1,277	1,351	1,434	1,520	1,611	1,707
Total	1,513	1,594	1,681	1,774	1,876	1,990	2,108	2,255	2,369	2,511	2,662	2,821	2,991	3,171	3,361	3,562

Songinohairhan District : Residential Demand		1995	1996	1997	1998	1999	2000	2001	2002	2003	2004	2005	2006	2007	2008	2009	2010
		No. of Honso															
1	113	120	129	136	145	151	162	170	182	190	203	217	226	242	251	267	
2	109	116	125	131	140	146	157	164	176	184	196	210	218	233	243	258	
3	163	173	186	196	209	218	234	246	263	275	293	314	326	349	363	386	
4	58	61	66	69	74	77	83	87	93	98	104	111	116	124	129	137	
5	69	73	78	82	88	92	98	103	111	116	123	132	137	147	153	162	
6	26	28	30	31	33	35	37	39	42	44	47	50	52	56	58	62	
7	74	79	85	89	95	99	107	112	120	125	134	143	149	159	165	176	
8	126	133	143	151	161	168	180	189	202	212	226	241	251	269	279	297	
9	304	323	348	365	390	406	437	458	491	513	546	584	608	651	677	719	
10	238	252	271	285	305	317	341	358	383	400	427	456	475	508	529	561	
11	128	136	147	154	165	171	184	193	207	216	231	247	257	275	286	303	
12	771	818	881	924	988	1,029	1,106	1,160	1,243	1,299	1,384	1,480	1,541	1,649	1,715	1,820	
13	938	995	1,072	1,125	1,202	1,252	1,346	1,412	1,512	1,581	1,685	1,801	1,876	2,006	2,087	2,215	
14	795	843	908	953	1,019	1,061	1,141	1,197	1,282	1,340	1,428	1,527	1,590	1,701	1,768	1,877	
15	1,456	1,544	1,663	1,746	1,866	1,942	2,089	2,191	2,347	2,453	2,615	2,796	2,911	3,114	3,238	3,438	
16	841	893	961	1,009	1,078	1,123	1,207	1,266	1,356	1,418	1,511	1,616	1,683	1,800	1,872	1,987	
17	883	937	1,009	1,059	1,132	1,178	1,267	1,329	1,423	1,488	1,586	1,696	1,766	1,889	1,964	2,085	
18	1,041	1,104	1,189	1,248	1,333	1,388	1,493	1,566	1,677	1,753	1,869	1,998	2,080	2,225	2,314	2,457	
19	444	471	508	533	569	593	638	669	716	749	798	853	889	951	988	1,049	
20	19	20	22	23	25	26	28	29	31	33	35	37	39	41	43	46	
21	102	109	117	123	131	137	147	154	165	173	184	197	205	219	228	242	
Total	8,698	9,228	9,938	10,432	11,148	11,609	12,482	13,092	14,022	14,660	15,625	16,706	17,395	18,608	19,350	20,544	

Songinohairhan District : Business + Residential Demand																
No. of Hiroo	1995	1996	1997	1998	1999	2000	2001	2002	2003	2004	2005	2006	2007	2008	2009	2010
1	153	162	173	183	195	204	218	229	245	256	273	292	305	326	340	361
2	109	116	125	131	140	146	157	164	176	184	196	210	218	233	243	258
3	173	183	197	207	221	231	247	260	278	291	310	332	345	369	384	409
4	178	188	199	210	223	235	250	264	281	297	315	335	353	376	396	420
5	203	215	228	240	255	269	285	302	321	339	360	383	403	429	452	479
6	26	28	30	31	33	35	37	39	42	44	47	50	52	56	58	62
7	116	123	131	138	147	154	165	173	185	194	207	221	231	246	257	274
8	137	145	155	164	175	183	196	206	220	231	246	262	273	292	304	323
9	314	333	359	376	402	419	450	472	506	529	563	602	627	671	698	742
10	238	252	271	285	305	317	341	358	383	400	427	456	475	508	529	561
11	128	136	147	154	165	171	184	193	207	216	231	247	257	275	286	303
12	790	838	902	947	1,012	1,054	1,133	1,188	1,273	1,331	1,418	1,516	1,579	1,689	1,758	1,865
13	956	1,014	1,092	1,146	1,224	1,275	1,371	1,438	1,540	1,610	1,716	1,834	1,911	2,043	2,126	2,256
14	811	860	926	972	1,039	1,082	1,163	1,221	1,307	1,367	1,456	1,557	1,622	1,735	1,804	1,915
15	1,462	1,551	1,670	1,754	1,874	1,950	2,098	2,200	2,357	2,464	2,626	2,808	2,924	3,127	3,252	3,453
16	881	935	1,005	1,056	1,128	1,176	1,263	1,325	1,419	1,484	1,581	1,691	1,762	1,884	1,961	2,081
17	891	945	1,018	1,068	1,142	1,189	1,278	1,341	1,436	1,501	1,600	1,711	1,782	1,906	1,982	2,104
18	1,289	1,365	1,465	1,539	1,640	1,714	1,839	1,933	2,065	2,165	2,306	2,460	2,570	2,745	2,865	3,041
19	502	532	572	601	640	669	718	754	806	845	899	960	1,003	1,072	1,116	1,185
20	27	28	31	32	35	37	39	41	44	46	49	52	55	58	61	65
21	827	873	923	972	1,029	1,089	1,158	1,226	1,300	1,377	1,461	1,548	1,639	1,739	1,839	1,949
Total	10,211	10,822	11,619	12,206	13,024	13,599	14,590	15,327	16,391	17,171	18,287	19,527	20,386	21,779	22,711	24,106

Bayanzurh District		in 1993							Remarks	
		Telephone		R + W	Demand	Old Site Name	New Site Name			
No. of Horoo	Population	Household	Admn. & Busi.					Resident	Waiter	Admn. & Busi.
1	4,645	1,190	509	567	384	951	1,460	ATC-5	ATC-5	Ger
2	5,028	1,232	59	75	120	195	254	ATC-5	ATC-5	
3	6,261	1,430	165	757	341	1,078	1,243	ATC-5	ATC-5	
4	6,660	1,569	141	462	465	927	1,068	ATC-5	ATC-5	
5	5,170	1,354	420	234	243	477	897	ATC-5	ATC-5	
6	6,098	1,804	197	261	326	587	784	ATC-5	ATC-5	Ger / Apartment
7	5,864	1,431	18	333	610	943	961	ATC-5	ATC-5	
8	4,972	1,015	102	72	71	143	245	ATC-5	ATC-5	Ger / Apartment
9	4,510	1,067	4	68	160	228	232	ATC-5	ATC-51	Ger
10	5,311	1,392	92	60	81	141	233	ATC-5	ATC-52	Ger / Apartment
11	3,044	657	5	45	0	45	50	HO	HO	Ger (Honhor)
12	4,572	1,033	0	20	85	105	105	ATC-5	ATC-52	Ger
13	2,504	581	0	8	151	159	159	ATC-5	ATC-5	Ger
14	3,165	715	2	23	85	108	110	ATC-5	ATC-5	
15	5,135	1,109	15	400	567	967	982	ATC-5	ATC-5	
16	8,381	1,961	46	653	526	1,179	1,225	ATC-5	ATC-5	Ger / Apartment
17	4,781	1,110	5	93	34	127	132	ATC-5	ATC-51	Ger
18	6,234	1,424	22	467	595	1,062	1,084	ATC-5	ATC-5	
19	No Data	No Data	5	0	0	0	5	ATC-5	ATC-5	Industry Area (Nov, 1995)
20	3,550	833	9	20	0	20	29	GA	GA	Gachaurt (Survey Data)
Total	95,885	22,907	1,816	4,598	4,844	9,442	11,258			

Bayanzurh District : Business Demand																				
No. of Horoo	1995	1996	1997	1998	1999	2000	2001	2002	2003	2004	2005	2006	2007	2008	2009	2010				
1	460	484	511	540	570	605	641	679	720	768	810	859	910	964	1,022	1,083				
2	53	56	59	63	66	70	74	79	84	88	94	100	105	112	118	126				
3	149	157	166	175	185	196	208	220	234	247	262	278	295	313	331	351				
4	127	134	142	149	158	168	178	188	200	211	224	238	252	267	283	300				
5	379	400	422	445	471	499	529	561	594	630	668	708	750	796	843	893				
6	178	187	198	209	221	234	248	263	279	295	313	332	352	373	396	419				
7	16	17	18	19	20	21	23	24	25	27	29	30	32	34	36	38				
8	92	97	103	108	114	121	129	136	144	153	162	172	182	193	205	217				
9	4	4	4	4	4	5	5	5	6	6	6	7	7	8	8	9				
10	83	88	92	98	103	109	116	123	130	138	146	155	164	174	185	196				
11	5	5	5	5	6	6	6	7	7	7	8	8	9	9	10	11				
12	0	0	0	0	0	0	0	0	0	0	0	0	0	0	0	0				
13	0	0	0	0	0	0	0	0	0	0	0	0	0	0	0	0				
14	2	2	2	2	2	2	3	3	3	3	3	3	4	4	4	4				
15	14	14	15	16	17	18	19	20	21	22	24	25	27	28	30	32				
16	42	44	46	49	52	55	58	61	65	69	73	78	82	87	92	98				
17	5	5	5	5	6	6	6	7	7	7	8	8	9	9	10	11				
18	20	21	22	23	25	26	28	29	31	33	35	37	39	42	44	47				
19	5	5	5	5	6	6	6	7	7	7	8	8	9	9	10	11				
20	8	9	9	10	10	11	11	12	13	13	14	15	16	17	18	19				
Total	1,642	1,729	1,824	1,925	2,036	2,158	2,288	2,424	2,570	2,724	2,887	3,061	3,244	3,439	3,645	3,865				

Bayanzurh District : Residential Demand																				
No. of Heroo	1995	1996	1997	1998	1999	2000	2001	2002	2003	2004	2005	2006	2007	2008	2009	2010				
1	910	964	1,033	1,084	1,153	1,230	1,284	1,379	1,469	1,536	1,629	1,733	1,844	1,923	2,042	2,158				
2	187	198	212	222	236	252	265	283	301	315	334	355	378	394	419	443				
3	1,031	1,093	1,171	1,229	1,307	1,394	1,456	1,563	1,665	1,741	1,846	1,965	2,091	2,179	2,315	2,446				
4	887	940	1,007	1,057	1,124	1,199	1,252	1,344	1,432	1,497	1,588	1,690	1,798	1,874	1,990	2,104				
5	456	484	518	544	578	617	644	692	737	770	817	869	925	964	1,024	1,082				
6	561	595	638	669	712	759	793	851	907	948	1,005	1,070	1,138	1,187	1,260	1,332				
7	902	956	1,024	1,075	1,143	1,219	1,273	1,367	1,457	1,523	1,615	1,719	1,829	1,906	2,025	2,140				
8	137	145	155	163	173	185	193	207	221	231	245	261	277	289	307	325				
9	218	231	248	260	276	295	308	331	352	368	390	416	442	461	490	517				
10	135	143	153	161	171	182	190	204	218	228	241	257	273	285	303	320				
11	43	46	49	51	55	58	61	65	70	73	77	82	87	91	97	102				
12	100	106	114	120	127	136	142	152	162	170	180	191	204	212	225	238				
13	152	161	173	181	193	206	215	231	246	257	272	290	308	321	341	361				
14	103	110	117	123	131	140	146	157	167	174	185	197	209	218	232	245				
15	925	981	1,050	1,103	1,172	1,250	1,306	1,402	1,494	1,561	1,656	1,763	1,876	1,955	2,076	2,194				
16	1,128	1,195	1,281	1,344	1,429	1,525	1,592	1,710	1,821	1,904	2,019	2,149	2,287	2,384	2,531	2,675				
17	121	129	138	145	154	164	172	184	196	205	218	231	246	257	273	288				
18	1,016	1,077	1,153	1,211	1,287	1,373	1,434	1,540	1,640	1,715	1,819	1,936	2,060	2,147	2,280	2,410				
19	0	0	0	0	0	0	0	0	0	0	0	0	0	0	0	0				
20	19	20	22	23	24	26	27	29	31	32	34	36	39	40	43	45				
Total	9,031	9,574	10,256	10,765	11,445	12,210	12,751	13,691	14,586	15,248	16,170	17,210	18,311	19,087	20,273	21,425				

Bayanzurh District: Business + Residential Demand		1995	1996	1997	1998	1999	2000	2001	2002	2003	2004	2005	2006	2007	2008	2009	2010
		No. of Horo															
1	1,570	1,448	1,544	1,624	1,723	1,835	1,925	2,058	2,189	2,304	2,439	2,592	2,754	2,887	3,064	3,241	
2	240	254	271	285	302	322	337	362	385	403	428	455	483	506	537	569	
3	1,180	1,250	1,337	1,404	1,492	1,590	1,664	1,783	1,899	1,988	2,108	2,243	2,386	2,492	2,646	2,797	
4	1,014	1,074	1,149	1,206	1,282	1,367	1,430	1,532	1,632	1,708	1,812	1,928	2,050	2,141	2,273	2,404	
5	835	884	940	989	1,049	1,116	1,173	1,253	1,331	1,400	1,485	1,577	1,675	1,760	1,867	1,975	
6	739	782	836	878	933	993	1,041	1,114	1,186	1,243	1,318	1,402	1,490	1,560	1,656	1,751	
7	918	973	1,042	1,094	1,163	1,240	1,296	1,391	1,482	1,550	1,644	1,749	1,861	1,940	2,061	2,178	
8	229	242	258	271	287	306	322	343	365	384	407	433	459	482	512	542	
9	222	235	252	264	280	300	313	336	358	374	396	423	449	469	498	526	
10	218	231	245	259	274	291	306	327	348	366	387	412	437	459	488	516	
11	48	51	54	56	61	64	67	72	77	80	85	90	96	100	107	113	
12	100	106	114	120	127	136	142	152	162	170	180	191	204	212	225	238	
13	152	161	173	181	193	206	215	231	246	257	272	290	308	321	341	361	
14	105	112	119	125	133	142	149	160	170	177	188	200	213	222	236	249	
15	939	995	1,065	1,119	1,189	1,268	1,325	1,422	1,515	1,583	1,680	1,788	1,903	1,983	2,106	2,226	
16	1,170	1,239	1,327	1,393	1,481	1,580	1,650	1,771	1,886	1,973	2,092	2,227	2,369	2,471	2,623	2,773	
17	126	134	143	150	160	170	178	191	203	212	226	239	255	266	283	299	
18	1,036	1,098	1,175	1,234	1,312	1,399	1,462	1,569	1,671	1,748	1,854	1,973	2,099	2,189	2,324	2,457	
19	5	5	5	5	6	6	6	7	7	7	7	8	8	9	9	10	
20	27	29	31	33	34	37	38	41	44	45	48	51	55	57	61	64	
Total	10,673	11,303	12,080	12,690	13,481	14,368	15,039	16,115	17,156	17,972	19,057	20,271	21,555	22,526	23,918	25,290	

Khan-Uul District		in 1993										Remarks
		No. of Horoo	Population	Household	Telephone			R + W	Demand	Old Site Name	New Site Name	
Admi. & Business	Resident				Waiter							
1	6,602	1,662	95	578	440	1,018	1,111	ATC-34	ATC-4			
2	6,052	1,450	27	433	456	889	916	ATC-34	ATC-4			
3	4,838	1,232	675	146	204	350	1,025	ATC-34	ATC-4			
4	3,665	820	0	0	67	67	67	ATC-37Y	ATC-37Y	Ger		
5	4,233	968	0	0	89	89	89	ATC-37Y	ATC-37Y	Ger		
6	1,251	973	0	0	89	89	89	ATC-37Y	ATC-37Y	Ger		
7	3,539	799	0	0	59	59	59	ATC-37Y	ATC-37Y	Ger		
8	4,460	1,188	0	0	92	92	92	ATC-37Y	ATC-37Y	Ger		
9	4,277	864	218	349	10	359	577	ATC-37A	ATC-37A			
10	3,306	515	0	0	8	8	8	ATC-37A	ATC-37A			
11	1,622	424	208	23	14	37	245	ATC-34	ATC-4			
12	3,469	728	82	62	0	62	144	ATC-76	BIO			
13	3,000	600	40	20	30	50	90	SF	SF			
Total	50,314	12,223	1,343	1,611	1,558	3,169	4,512					

Biskombul (Survey Data)
Shuvuu Fabrics(Survey Data)

Khan-Uul District : Business Demand																
No. of Horoo	1995	1996	1997	1998	1999	2000	2001	2002	2003	2004	2005	2006	2007	2008	2009	2010
1	125	132	139	147	155	165	174	185	196	208	220	233	247	262	278	294
2	36	38	40	43	45	48	51	54	57	60	64	68	72	76	81	85
3	909	957	1,010	1,065	1,126	1,194	1,265	1,342	1,422	1,507	1,598	1,694	1,796	1,903	2,017	2,139
4	0	0	0	0	0	0	0	0	0	0	0	0	0	0	0	0
5	0	0	0	0	0	0	0	0	0	0	0	0	0	0	0	0
6	0	0	0	0	0	0	0	0	0	0	0	0	0	0	0	0
7	0	0	0	0	0	0	0	0	0	0	0	0	0	0	0	0
8	0	0	0	0	0	0	0	0	0	0	0	0	0	0	0	0
9	294	309	326	344	364	386	409	433	459	487	516	547	580	615	651	690
10	0	0	0	0	0	0	0	0	0	0	0	0	0	0	0	0
11	280	295	311	328	347	368	390	413	438	464	492	522	553	587	622	659
12	110	116	123	129	137	145	154	163	173	183	194	206	218	231	245	260
13	54	57	60	63	67	71	75	80	84	89	95	100	106	113	120	127
Total	1,808	1,904	2,009	2,119	2,241	2,377	2,518	2,670	2,829	2,998	3,179	3,370	3,572	3,787	4,014	4,254

Khan-Uul District : Residential Demand																
No. of House	1995	1996	1997	1998	1999	2000	2001	2002	2003	2004	2005	2006	2007	2008	2009	2010
1	1,408	1,504	1,572	1,699	1,762	1,889	2,029	2,129	2,276	2,380	2,535	2,638	2,820	3,014	3,134	3,324
2	1,230	1,314	1,373	1,484	1,539	1,649	1,772	1,858	1,988	2,078	2,213	2,304	2,462	2,632	2,736	2,904
3	484	517	540	584	606	649	697	731	782	818	871	907	969	1,036	1,077	1,143
4	93	99	103	112	116	124	134	140	150	157	167	174	186	198	206	219
5	123	132	137	149	154	165	177	186	199	208	222	231	247	263	274	291
6	123	132	137	149	154	165	177	186	199	208	222	231	247	263	274	291
7	82	87	91	98	102	109	118	123	132	138	147	153	163	175	182	193
8	127	136	142	154	159	171	183	192	206	215	229	238	255	272	283	300
9	497	531	554	599	621	666	715	750	803	839	894	930	994	1,063	1,105	1,173
10	11	12	12	13	14	15	16	17	18	19	20	21	22	24	25	26
11	51	55	57	62	64	69	74	77	83	87	92	96	102	110	114	121
12	86	92	96	103	107	115	124	130	139	145	154	161	172	184	191	202
13	69	74	77	83	87	93	100	104	112	117	124	130	138	148	154	163
Total	4,384	4,685	4,891	5,289	5,485	5,879	6,316	6,623	7,087	7,409	7,890	8,214	8,777	9,382	9,755	10,350

Khan-Uul District : Business + Residential Demand																
No. of Horoo	1995	1996	1997	1998	1999	2000	2001	2002	2003	2004	2005	2006	2007	2008	2009	2010
1	1,533	1,636	1,711	1,846	1,917	2,054	2,203	2,314	2,472	2,588	2,755	2,871	3,067	3,276	3,412	3,618
2	1,266	1,352	1,413	1,527	1,584	1,697	1,823	1,912	2,045	2,138	2,277	2,372	2,534	2,708	2,817	2,989
3	1,393	1,474	1,550	1,649	1,732	1,843	1,962	2,073	2,204	2,325	2,469	2,601	2,765	2,939	3,094	3,282
4	93	99	103	112	116	124	134	140	150	157	167	174	186	198	206	219
5	123	132	137	149	154	165	177	186	199	208	222	231	247	263	274	291
6	123	132	137	149	154	165	177	186	199	208	222	231	247	263	274	291
7	82	87	91	98	102	109	118	123	132	138	147	153	163	175	182	193
8	127	136	142	154	159	171	183	192	206	215	229	238	255	272	283	300
9	791	840	880	943	985	1,052	1,124	1,183	1,262	1,326	1,410	1,477	1,574	1,678	1,756	1,863
10	11	12	12	13	14	15	16	17	18	19	20	21	22	24	25	26
11	331	350	368	390	411	437	464	490	521	551	584	618	655	697	736	780
12	196	208	219	232	244	260	278	293	312	328	348	367	390	415	436	462
13	123	131	137	146	154	164	175	184	196	206	219	230	244	261	274	290
Total	6,192	6,589	6,900	7,408	7,726	8,236	8,834	9,295	9,916	10,407	11,069	11,584	12,349	13,169	13,769	14,604

Suhbaatar District : No. of Horoo (16)

Demand in Horoo

Horoo No.
in 2000
in 2005
in 2010

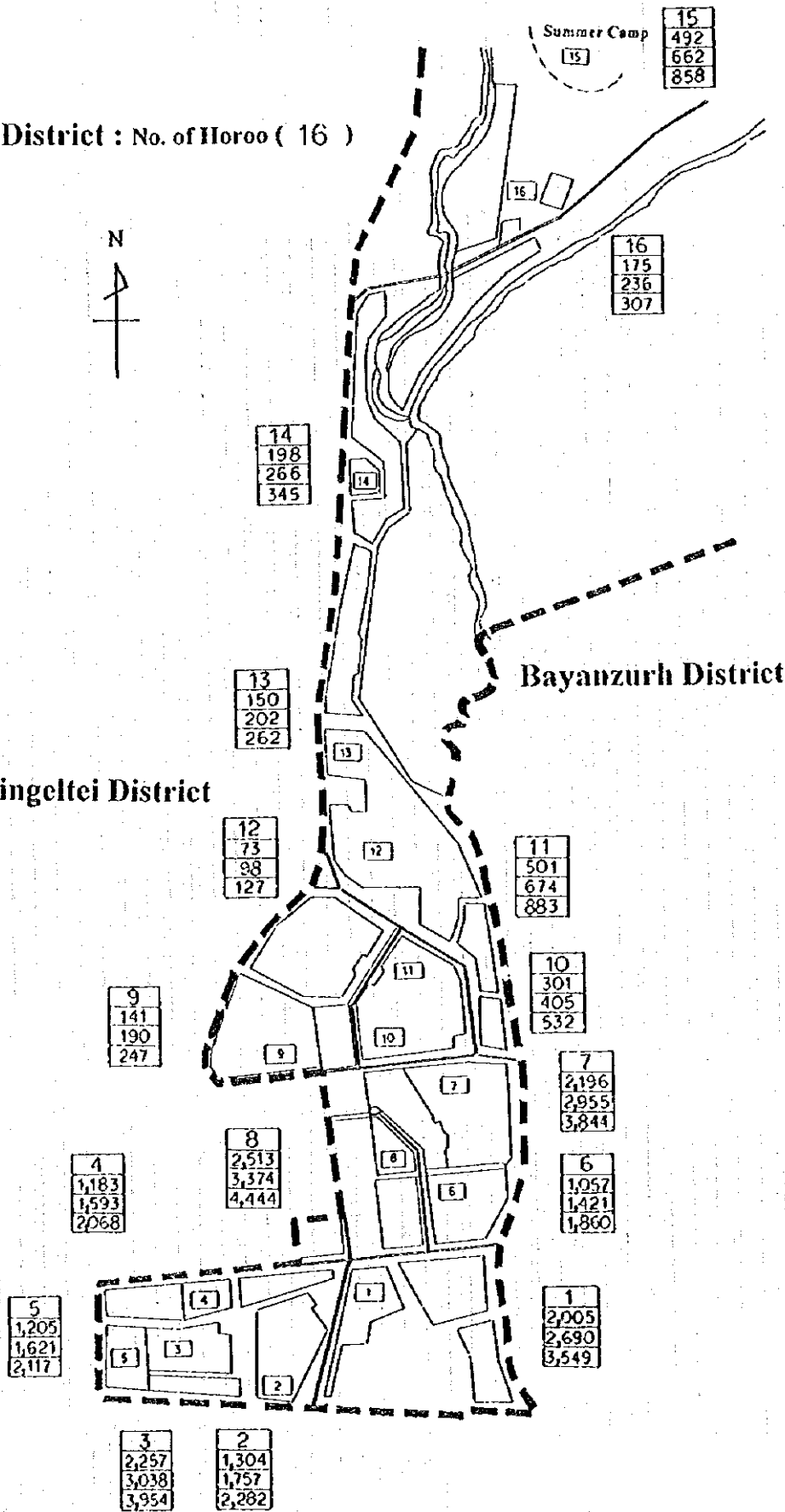

Chingeltei District : No. of Horoo (18)

Demand in Horoo

Horoo No.
in 2000
in 2005
in 2010

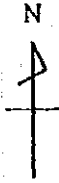

Songinohairhan District

Subbatar District

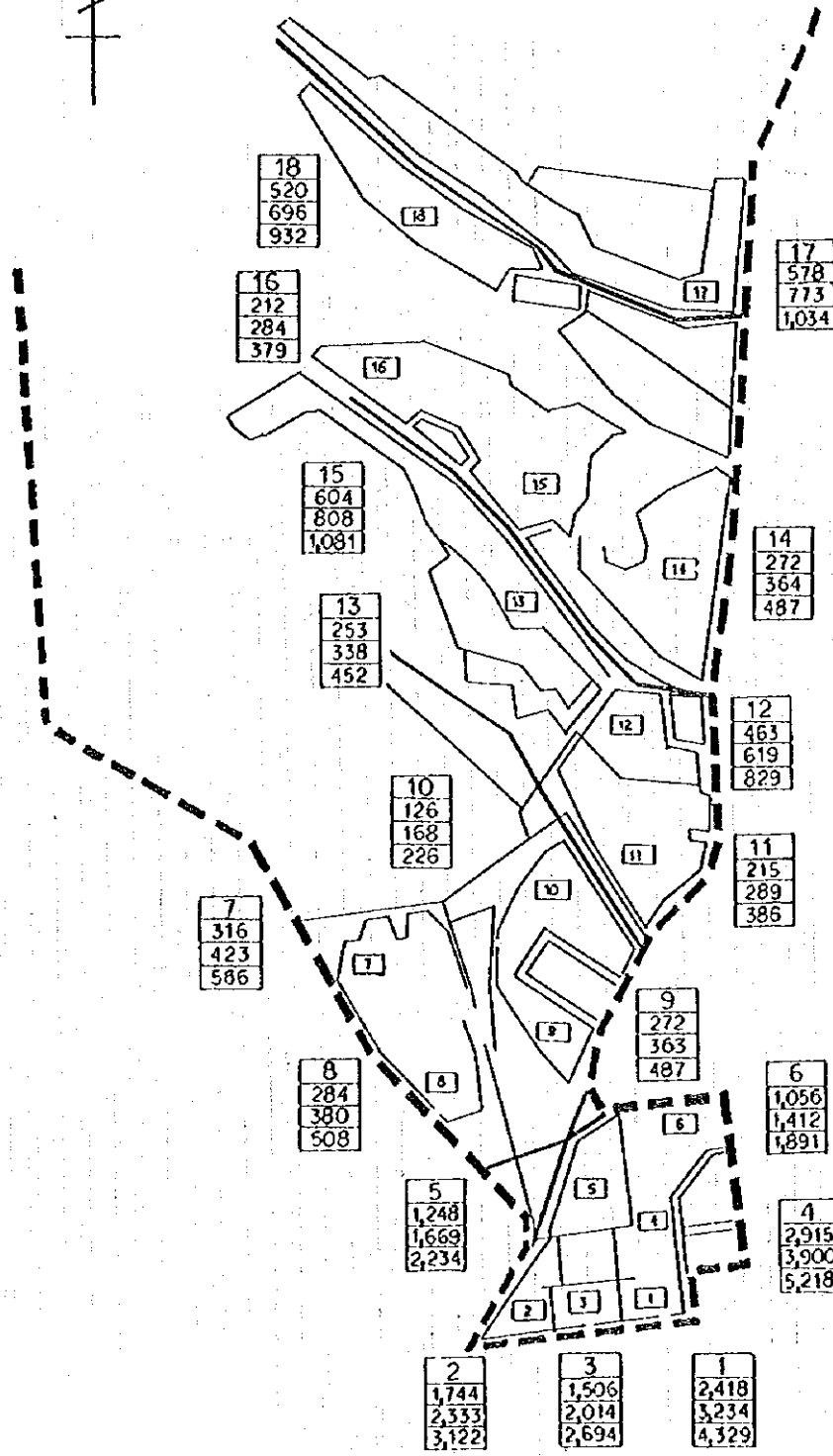

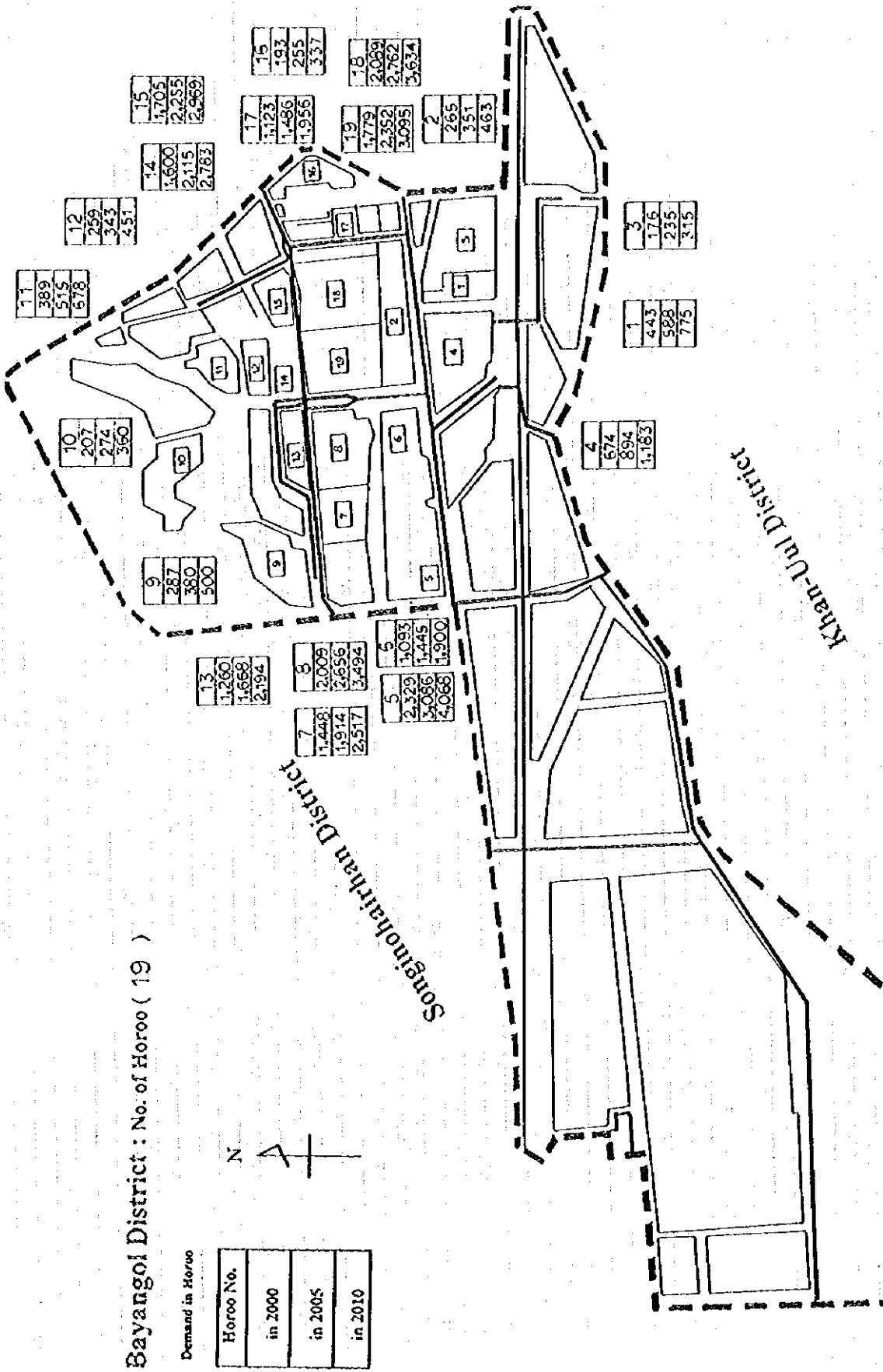

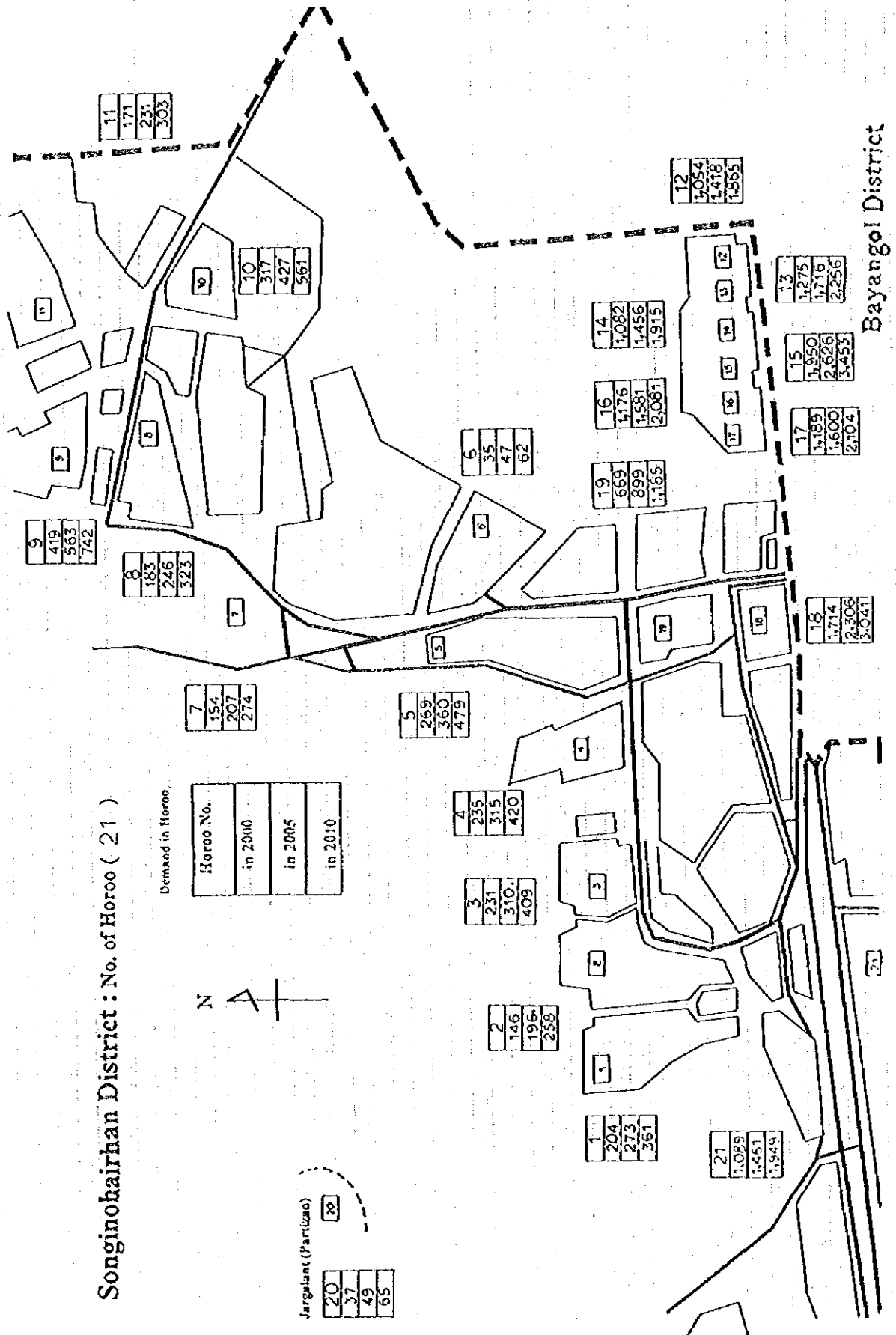

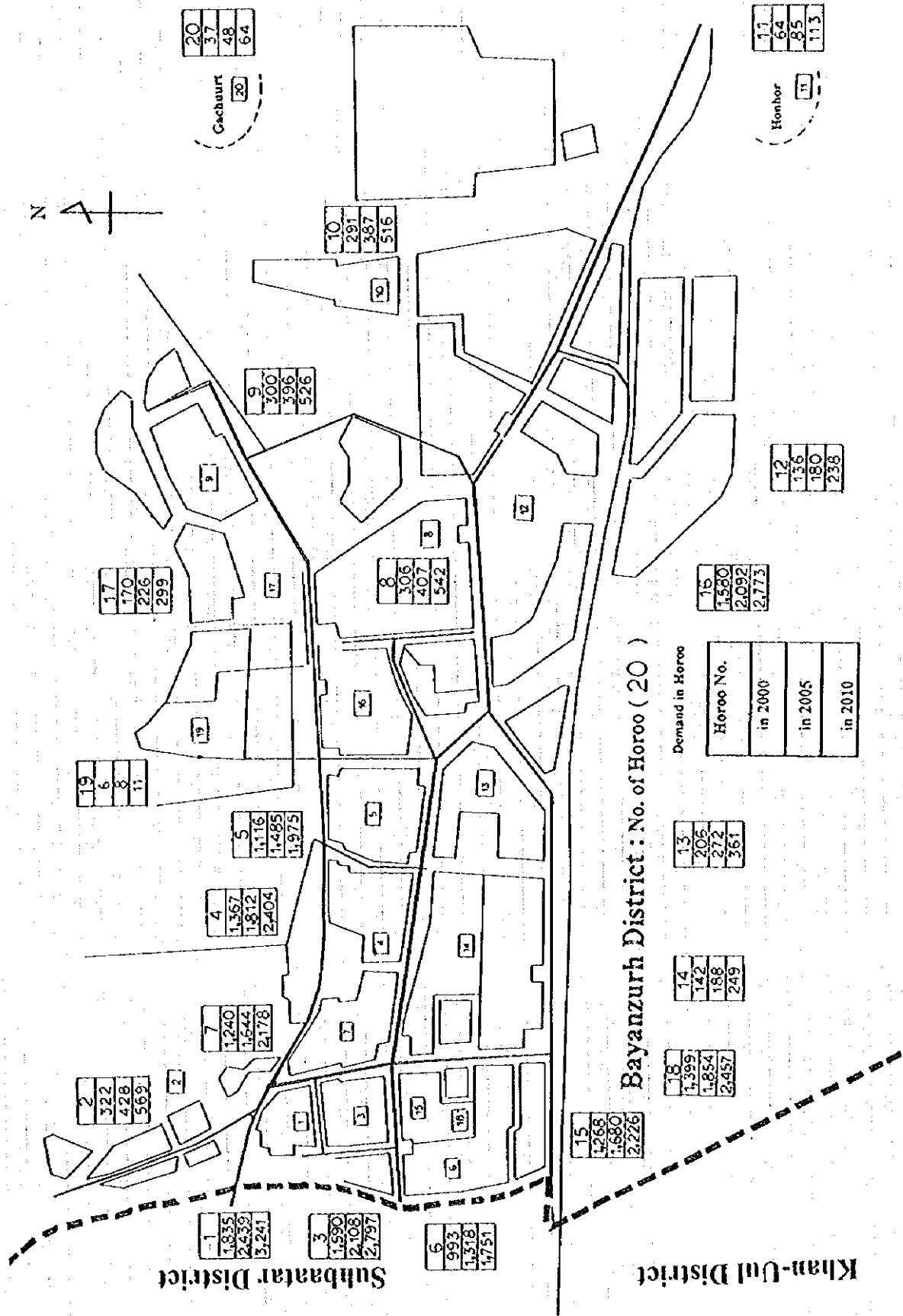

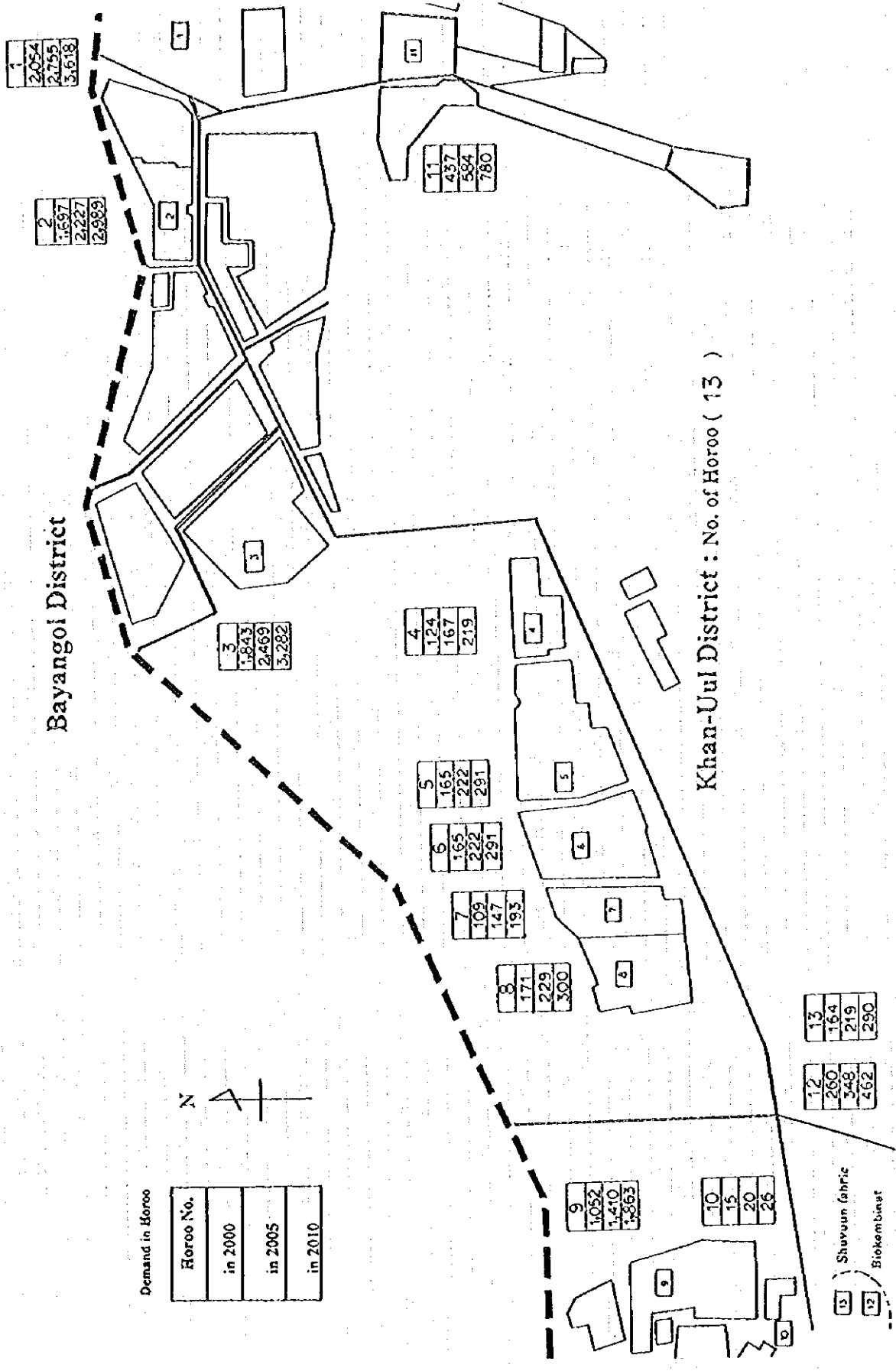

CHAPTER 5

ANALIZES DATA ON SWITCHING SYSTEM

CHAPTER 5

DATA ON SWITCHING SYSTEM

1 The Configuration of Host Exchanges and RSUs

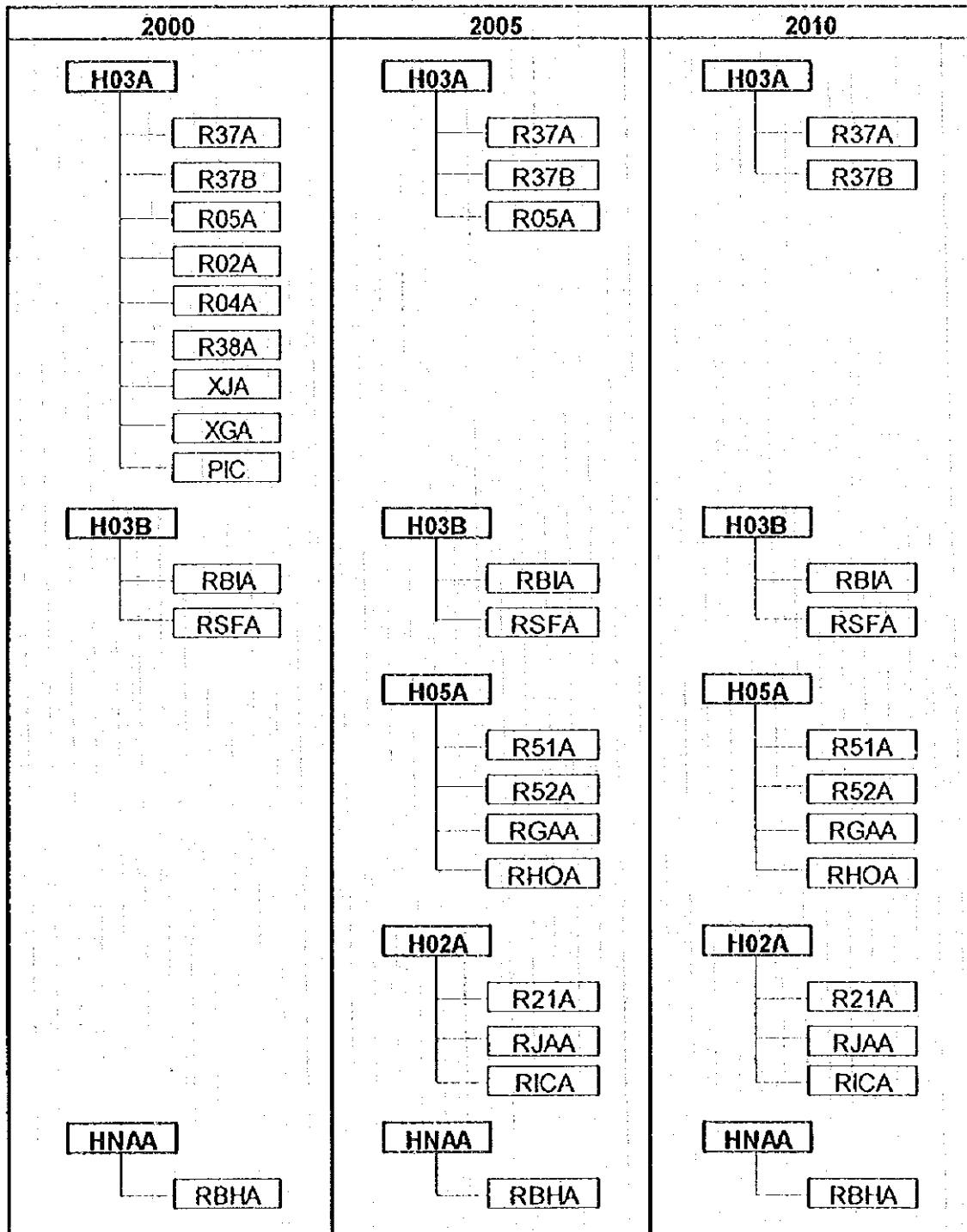

2 A List of Exchanges in Operation from 1995 to 2010

Table 5-2-1 A List of Exchanges in Operation from 1995 to 2010

ATC	SWITCH TYPE	1995	1996	1997	1998	1999	2000	2001	2002	2003	2004	2005	2006	2007	2008	2009	2010
A1C-3	Host(SXS)	S05	S03	H09A	H09A	H03A	H03A	H03A	H03A	H03A	H03A	H03A	H03A	H03A	H03A	H03A	H03A
	Host(DGT)	H03A	H03A	H09A	H09A	H03B	H03B	H03B	H03B	H03B	H03B	H03B	H03B	H03B	H03B	H03B	H03B
A1C-4	RSU	R04A	R04A	R04A	R04A	R04A	R04A	R04A	R04A	R04A	R04A	R04A	R04A	R04A	R04A	R04A	R04A
	HOST(DGT)	LS	LS	LS	LS	LS	LS	LS	LS	LS	LS	LS	LS	LS	LS	LS	LS
A1C-3/A	RSU	R37A	R37A	R37A	R37A	R37A	R37A	R37A	R37A	R37A	R37A	R37A	R37A	R37A	R37A	R37A	R37A
	RSU	R37B	R37B	R37B	R37B	R37B	R37B	R37B	R37B	R37B	R37B	R37B	R37B	R37B	R37B	R37B	R37B
A1C-3/Y	RSU	M73	M73	M73	M73	M73	M73	M73	M73	M73	M73	M73	M73	M73	M73	M73	M73
	HOST(DGT)	LS	LS	LS	LS	LS	LS	LS	LS	LS	LS	LS	LS	LS	LS	LS	LS
A1C-5	HOST(SXS)	S05	S05	R05A	R05A	R05A	R05A	R05A	R05A	R05A	R05A	R05A	R05A	R05A	R05A	R05A	R05A
	RSU	R05A	R05A	R05A	R05A	R05A	R05A	R05A	R05A	R05A	R05A	R05A	R05A	R05A	R05A	R05A	R05A
A1C-5I (Sharhad)	RSU																
	RSU																
A1C-5Z (Amgalian)	RSU																
	RSU																
A1C-6	RSU	R06A	R06A	R06A	H06A	H06A	H06A	H06A	H06A	H06A	H06A	H06A	H06A	H06A	H06A	H06A	H06A
	RSU																
A1C-2	RSU	R02A	R02A	R02A	R02A	R02A	R02A	R02A	R02A	R02A	R02A	R02A	R02A	R02A	R02A	R02A	R02A
	RSU	R02B	R02B	R02B	R02B	R02B	R02B	R02B	R02B	R02B	R02B	R02B	R02B	R02B	R02B	R02B	R02B
A1C-3B	RSU	R38A	R38A	R38A	R38A	R38A	R38A	R38A	R38A	R38A	R38A	R38A	R38A	R38A	R38A	R38A	R38A
	RSU																
A1C-2I	RSU	XJA	XJA	XJA	XJA	XJA	XJA	XJA	XJA	XJA	XJA	XJA	XJA	XJA	XJA	XJA	XJA
	RSU	XFO	XFO	XFO	XFO	XFO	XFO	XFO	XFO	XFO	XFO	XFO	XFO	XFO	XFO	XFO	XFO
Jagalan	RSU	XJA	XJA	XJA	XJA	XJA	XJA	XJA	XJA	XJA	XJA	XJA	XJA	XJA	XJA	XJA	XJA
	RSU	XFO	XFO	XFO	XFO	XFO	XFO	XFO	XFO	XFO	XFO	XFO	XFO	XFO	XFO	XFO	XFO
Honhor	RSU	XGA	XGA	XGA	XGA	XGA	XGA	XGA	XGA	XGA	XGA	XGA	XGA	XGA	XGA	XGA	XGA
	RSU	XBI	XBI	XBI	XBI	XBI	XBI	XBI	XBI	XBI	XBI	XBI	XBI	XBI	XBI	XBI	XBI
Gachuut	RSU	XGA	XGA	XGA	XGA	XGA	XGA	XGA	XGA	XGA	XGA	XGA	XGA	XGA	XGA	XGA	XGA
	RSU	XBI	XBI	XBI	XBI	XBI	XBI	XBI	XBI	XBI	XBI	XBI	XBI	XBI	XBI	XBI	XBI
dikombinat	RSU	PSF	PSF	PSF	PSF	PSF	PSF	PSF	PSF	PSF	PSF	PSF	PSF	PSF	PSF	PSF	PSF
	RSU	PIC	PIC	PIC	PIC	PIC	PIC	PIC	PIC	PIC	PIC	PIC	PIC	PIC	PIC	PIC	PIC
Sruwin Fabnc	RSU	SNA	SNA	SNA	SNA	SNA	SNA	SNA	SNA	SNA	SNA	SNA	SNA	SNA	SNA	SNA	SNA
	RSU	PNA	PNA	PNA	PNA	PNA	PNA	PNA	PNA	PNA	PNA	PNA	PNA	PNA	PNA	PNA	PNA
Int. Children	RSU	XBN	XBN	XBN	XBN	XBN	XBN	XBN	XBN	XBN	XBN	XBN	XBN	XBN	XBN	XBN	XBN
	RSU	PBN1	PBN1	PBN1	PBN1	PBN1	PBN1	PBN1	PBN1	PBN1	PBN1	PBN1	PBN1	PBN1	PBN1	PBN1	PBN1
Nalaih	RSU	PNA	PNA	PNA	PNA	PNA	PNA	PNA	PNA	PNA	PNA	PNA	PNA	PNA	PNA	PNA	PNA
	RSU	XBN	XBN	XBN	XBN	XBN	XBN	XBN	XBN	XBN	XBN	XBN	XBN	XBN	XBN	XBN	XBN
baganuur	RSU	PBN1	PBN1	PBN1	PBN1	PBN1	PBN1	PBN1	PBN1	PBN1	PBN1	PBN1	PBN1	PBN1	PBN1	PBN1	PBN1
	RSU	PBN2	PBN2	PBN2	PBN2	PBN2	PBN2	PBN2	PBN2	PBN2	PBN2	PBN2	PBN2	PBN2	PBN2	PBN2	PBN2
baganangai	RSU	XBR	XBR	XBR	XBR	XBR	XBR	XBR	XBR	XBR	XBR	XBR	XBR	XBR	XBR	XBR	XBR
	RSU																
No. of SW Units	HOST(SXS)	3	6	1	1	5	4	3	2	4	4	4	4	4	4	4	4
	HOST(XB)	6	5	5	5	4	3	3	3	4	4	4	4	4	4	4	4
HOST(PBX)	HOST(DGT)	1	1	2	2	3	3	3	4	4	4	4	4	4	4	4	4
	HOST(DGT)	7	7	7	7	7	9	10	14	14	14	13	13	12	12	12	12
RSU	HOST(DGT)	7	7	7	6	7	9	10	14	14	14	13	13	12	12	12	12
	RSU																

3 Connection Model of ISDN

3.1 Circuit Switched Call

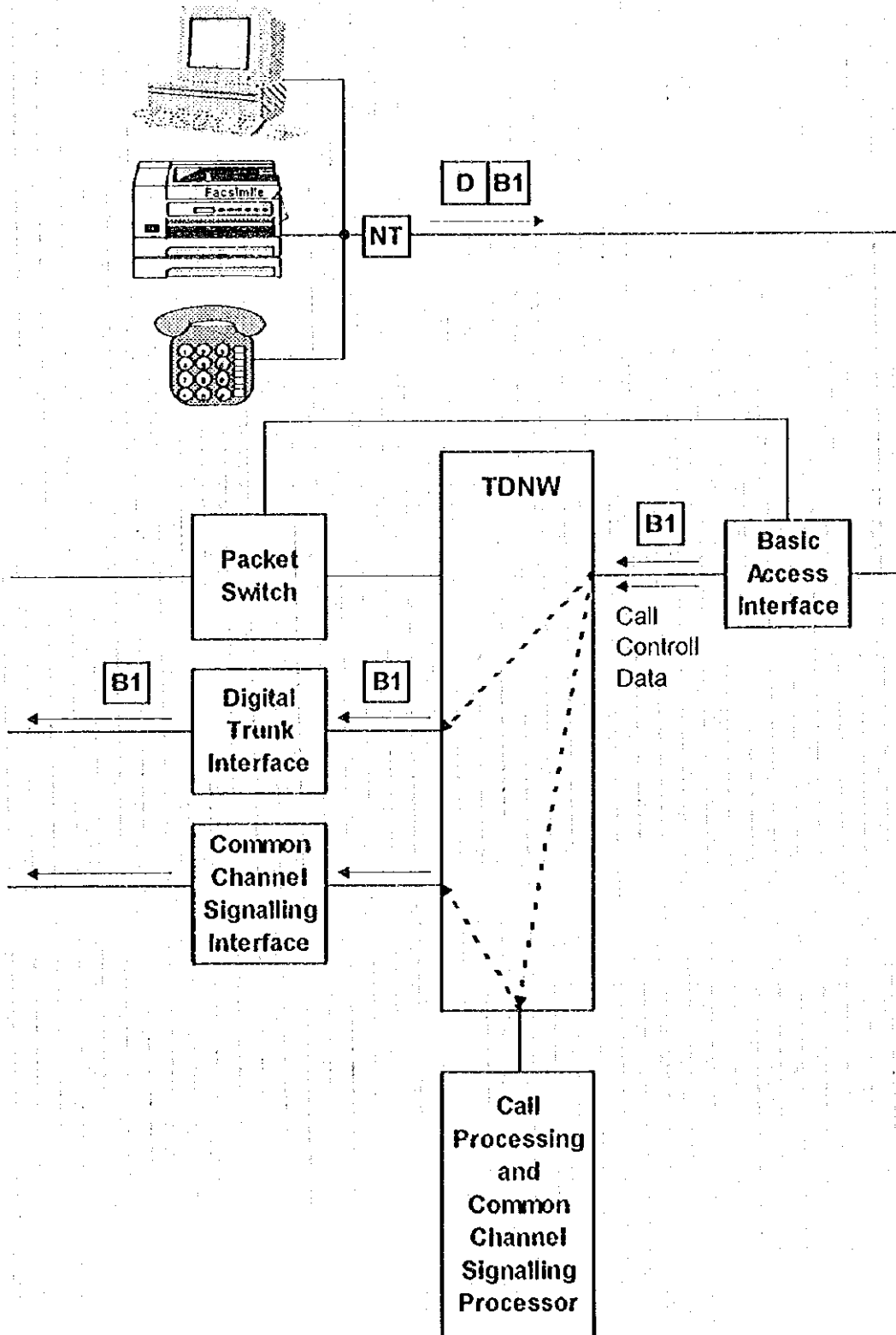

3.2 B-Channel Packet Call

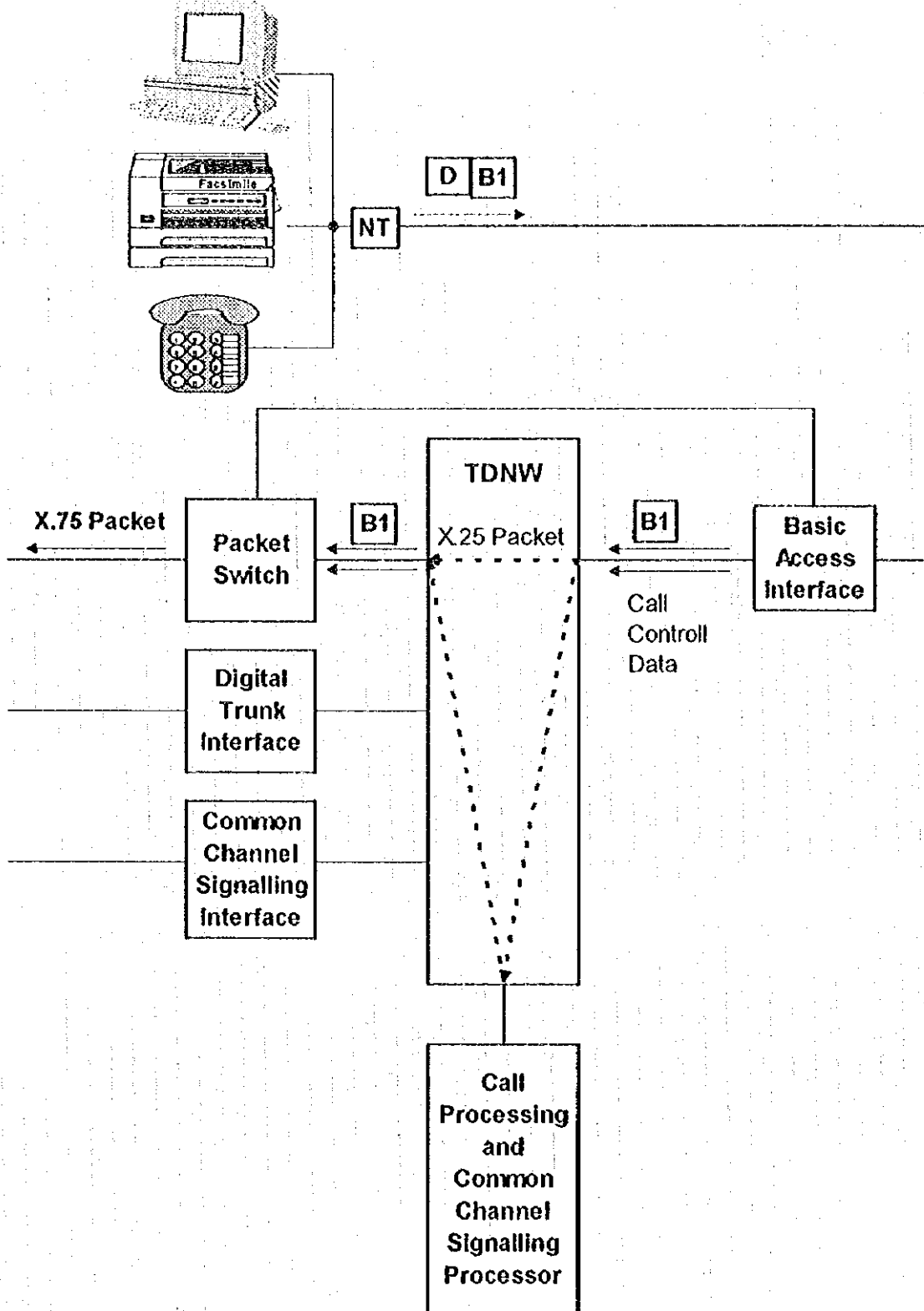

3.3 D-Channel Packet Call

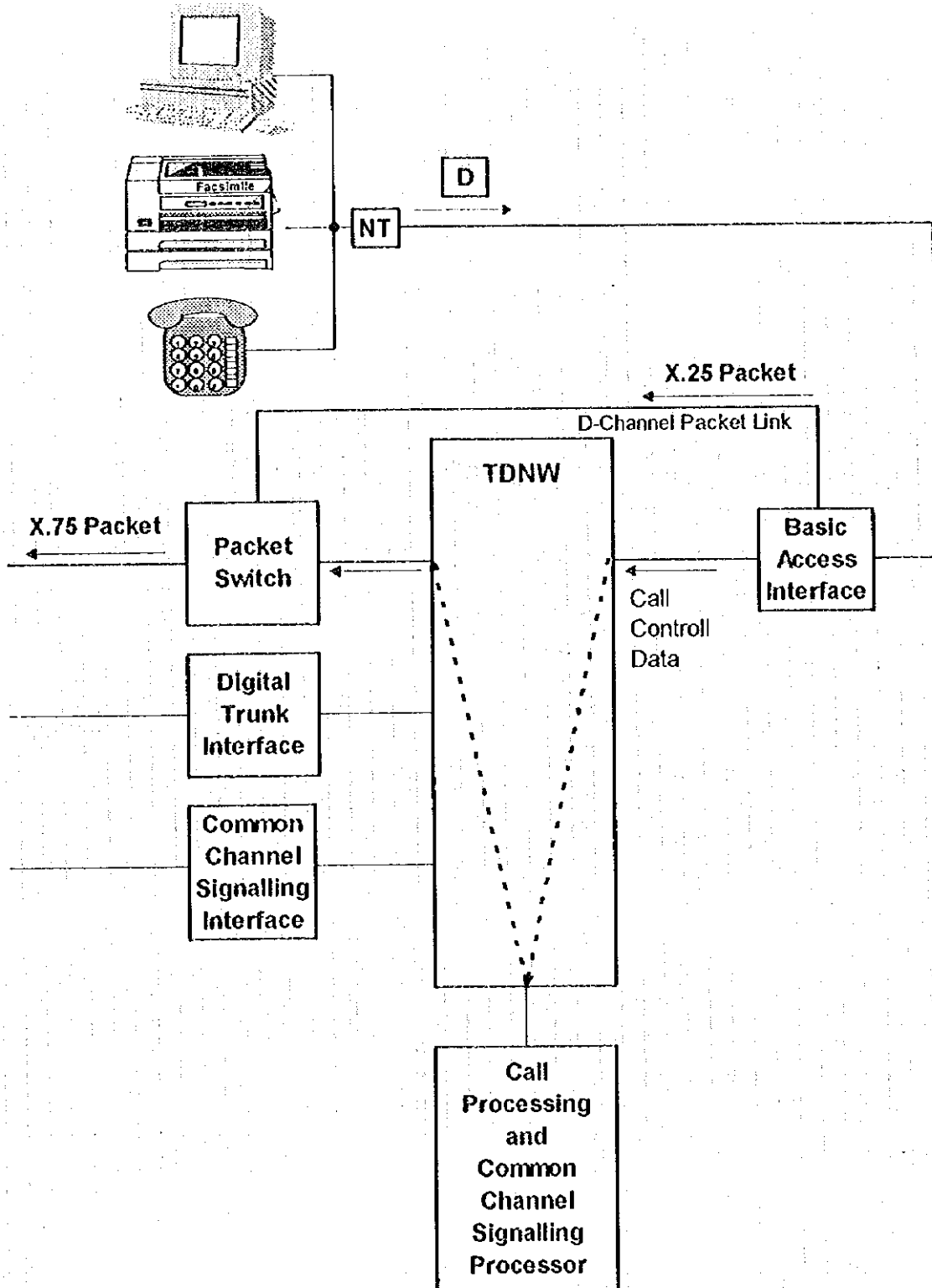

4 Implimentation Plan

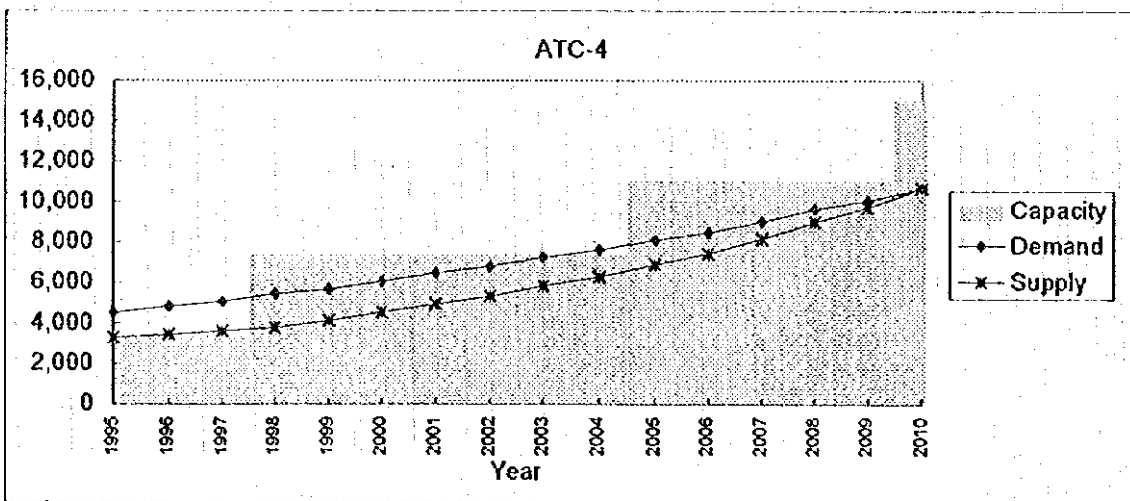
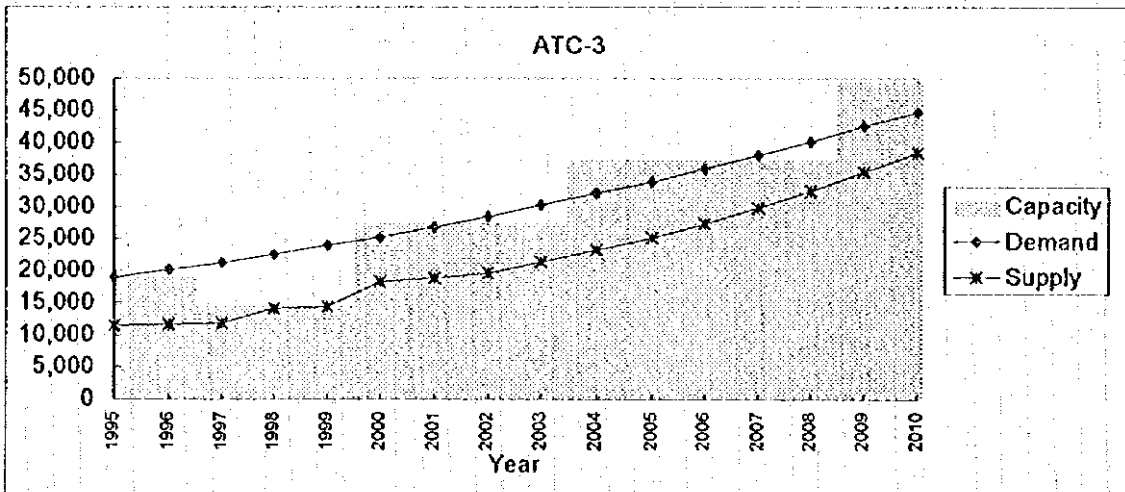
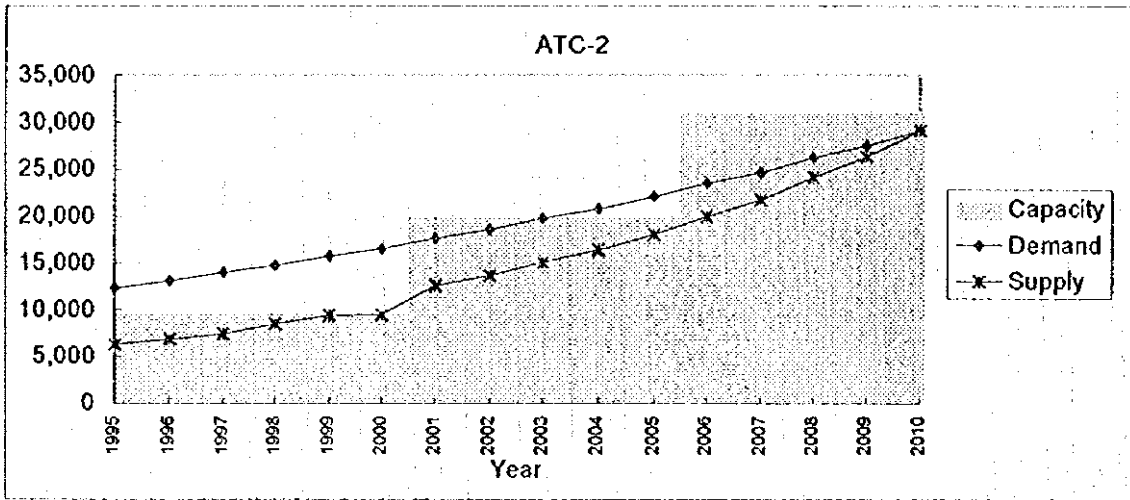

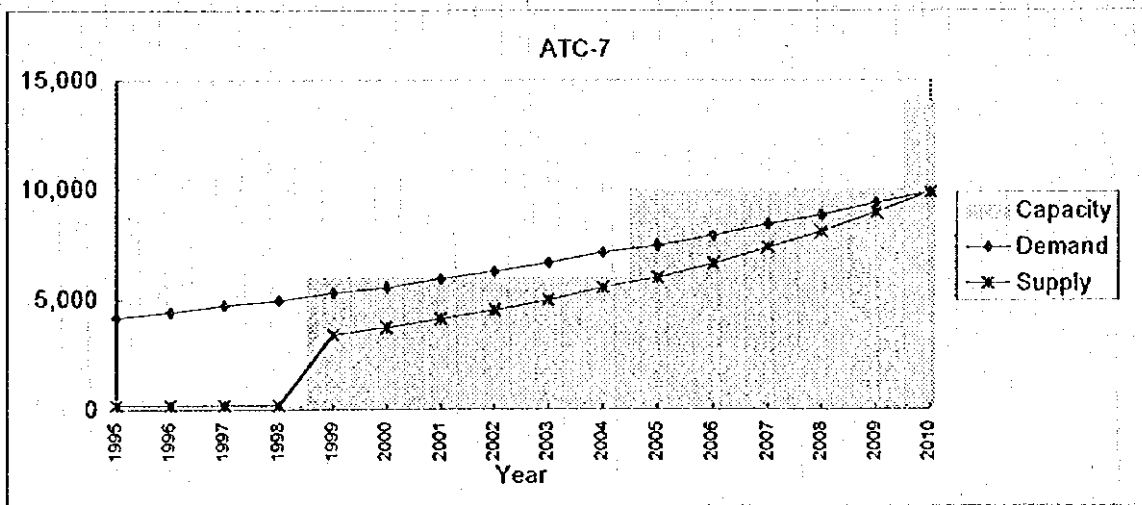
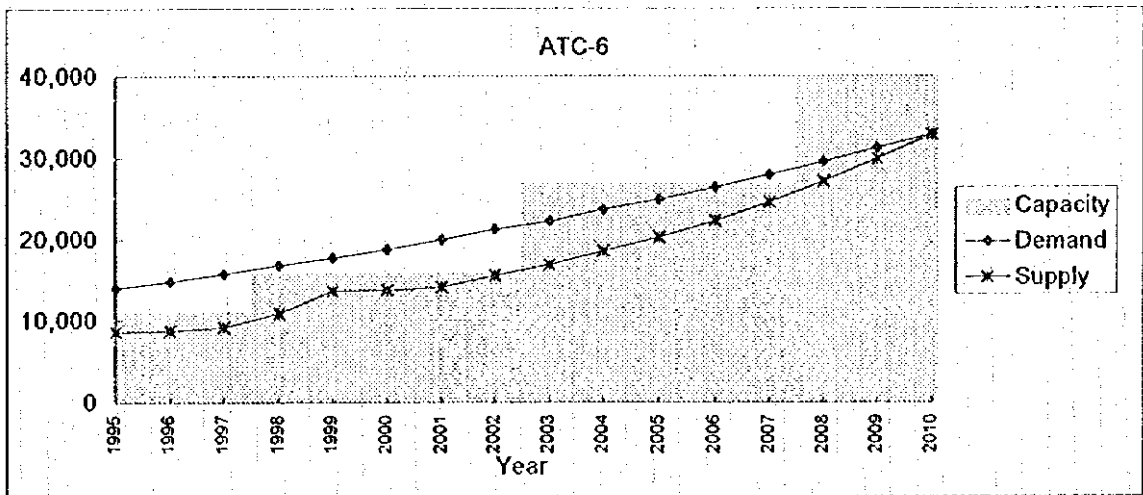
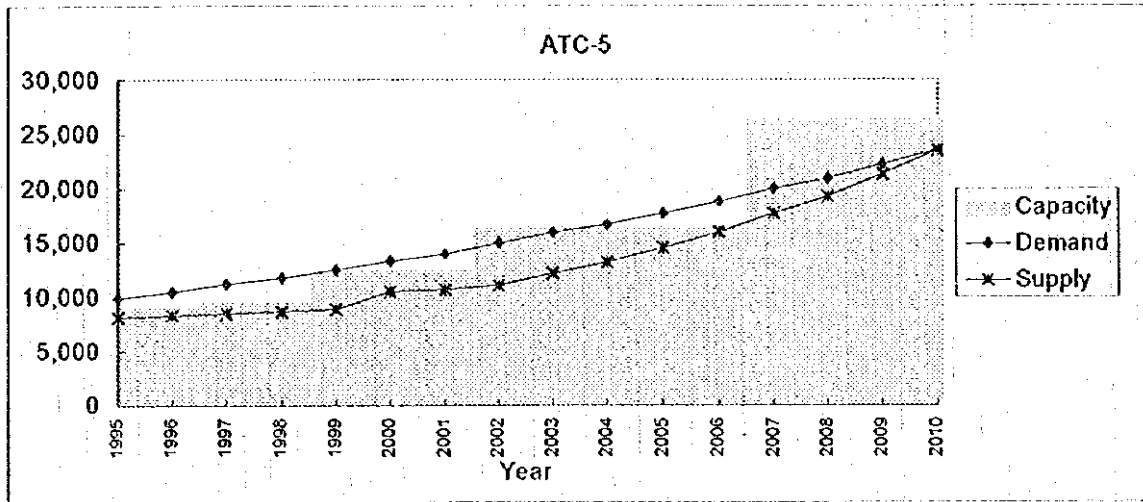

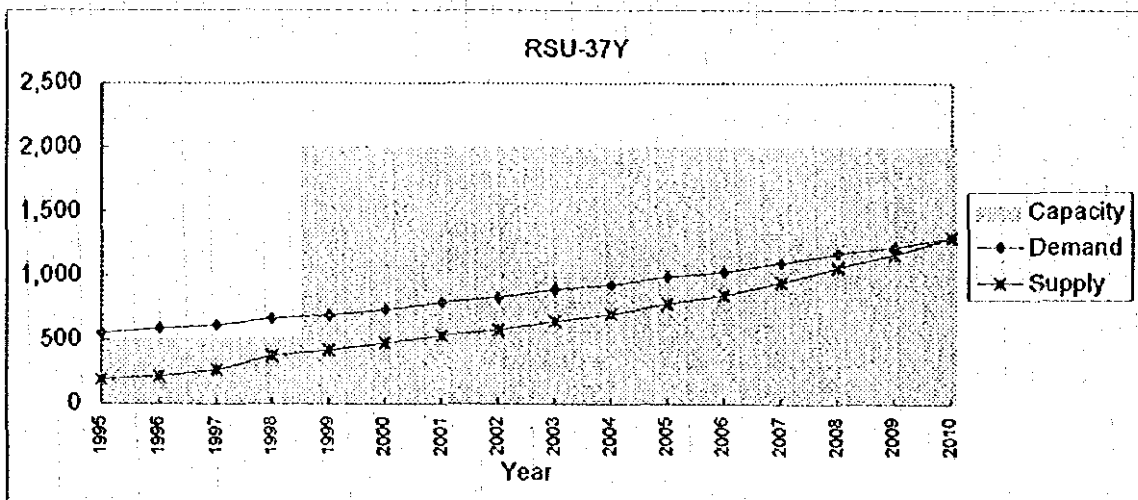
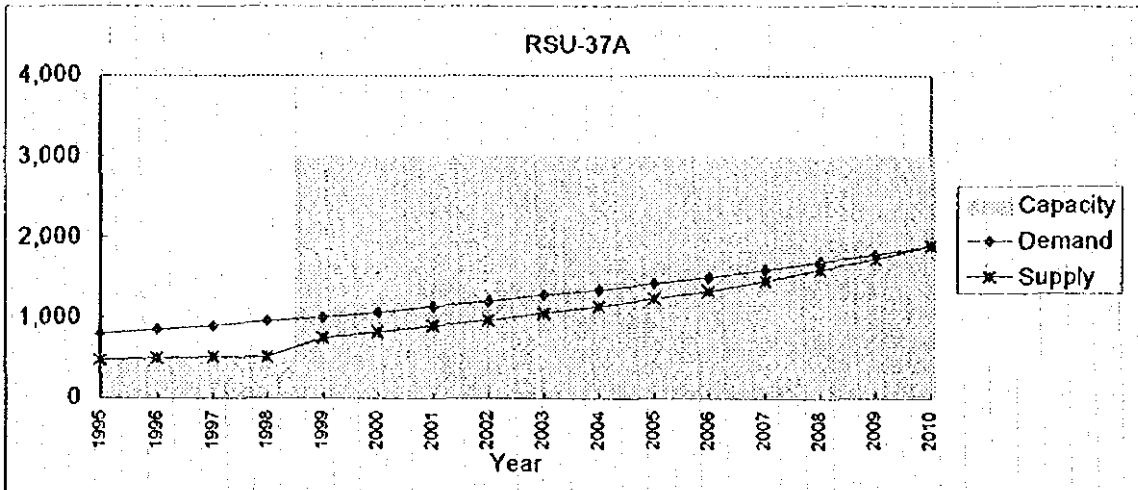
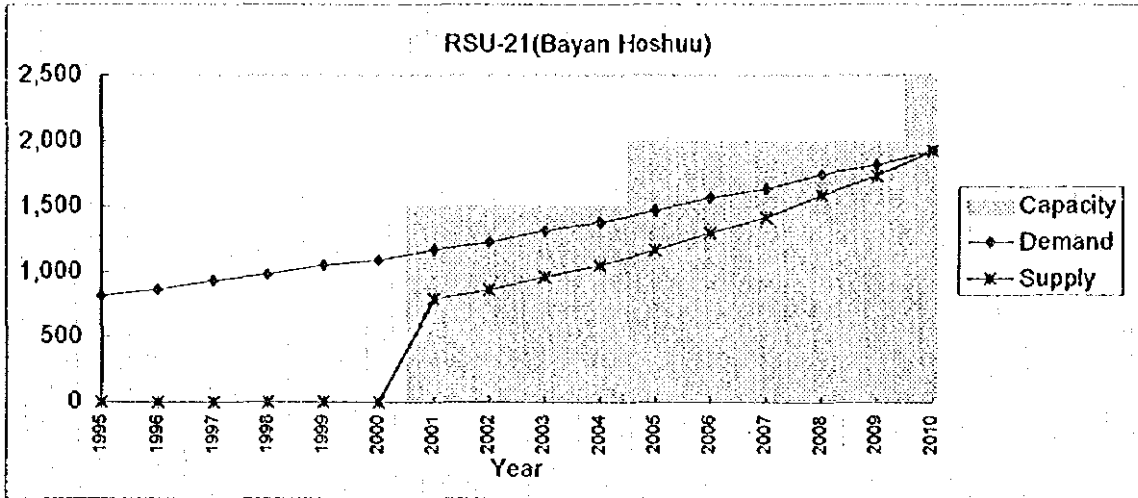

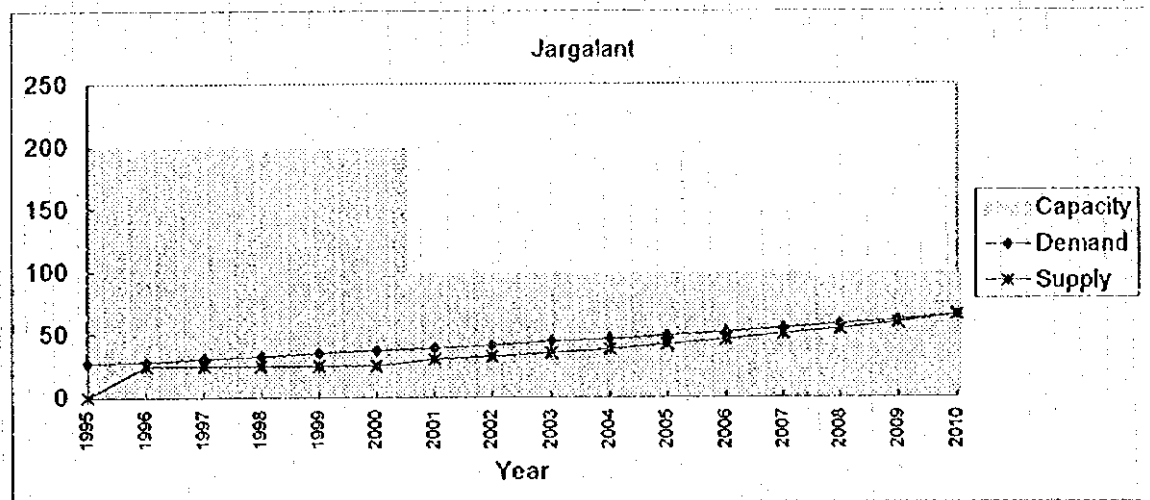
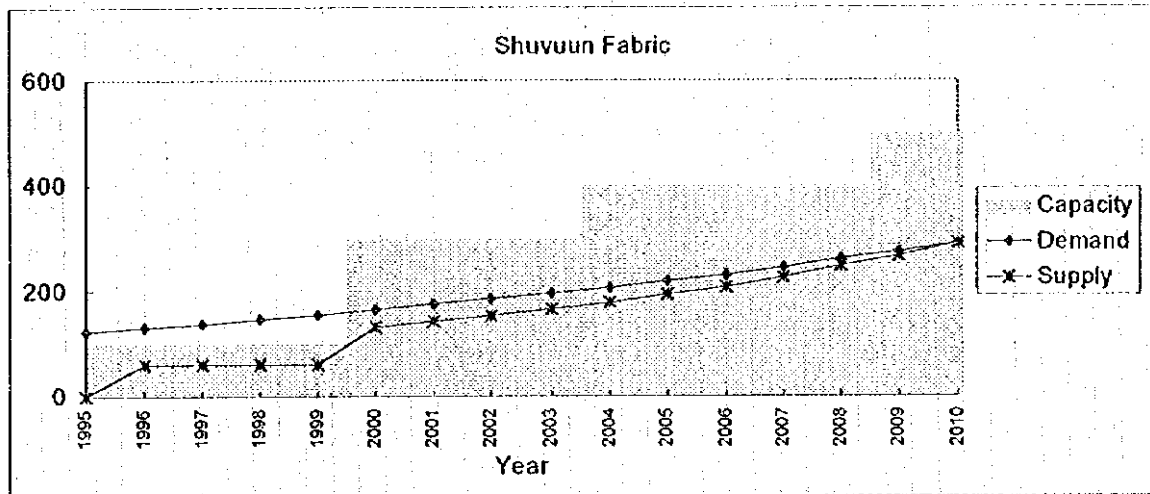
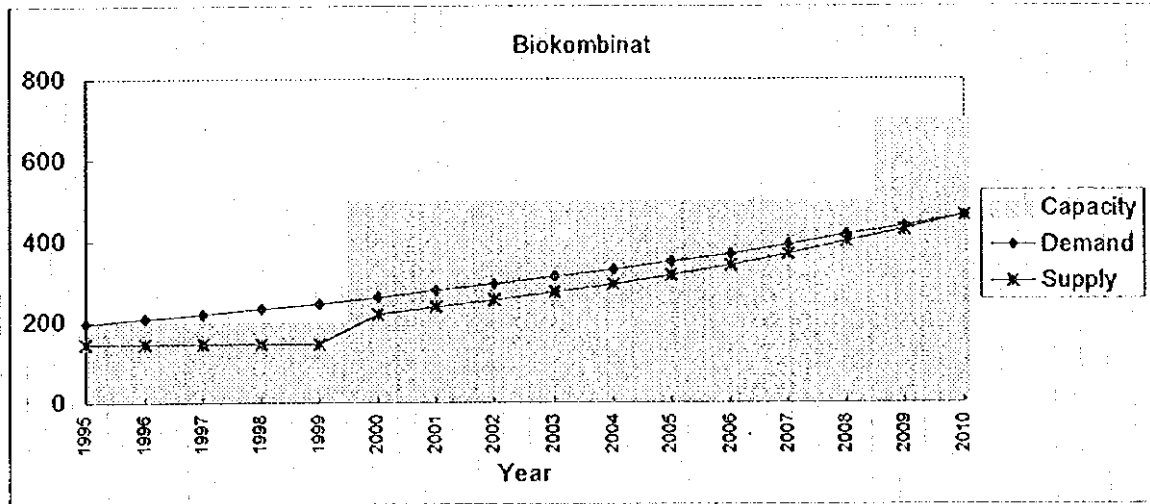

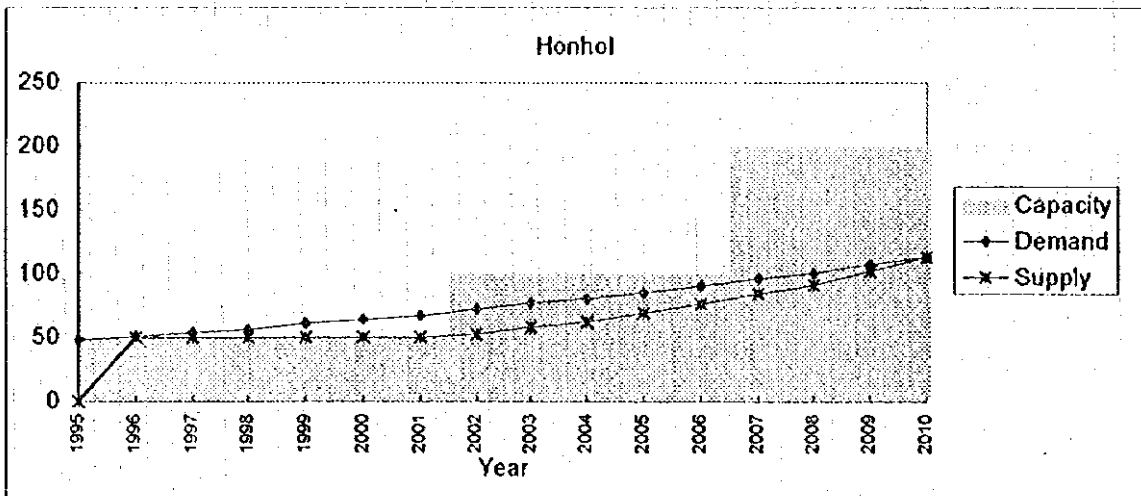
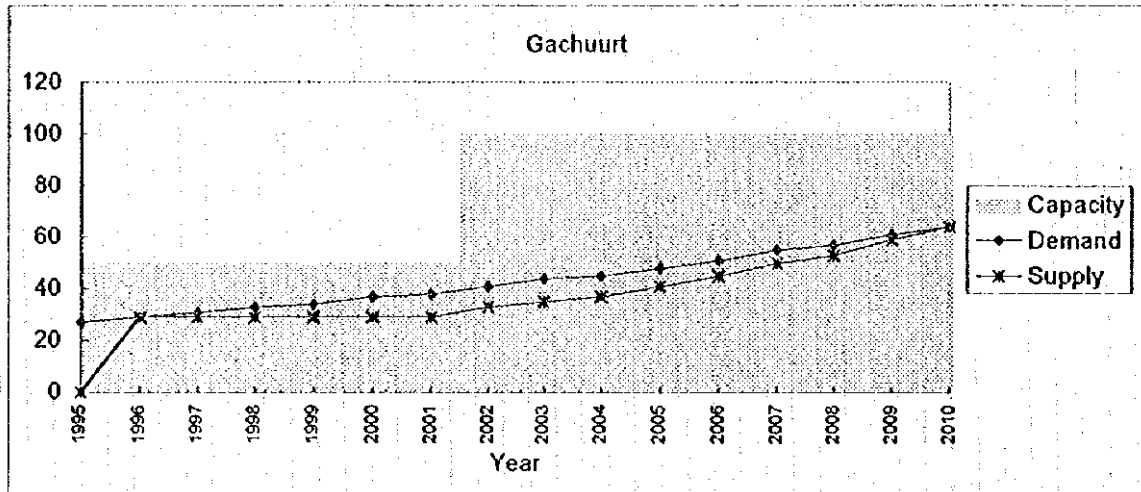
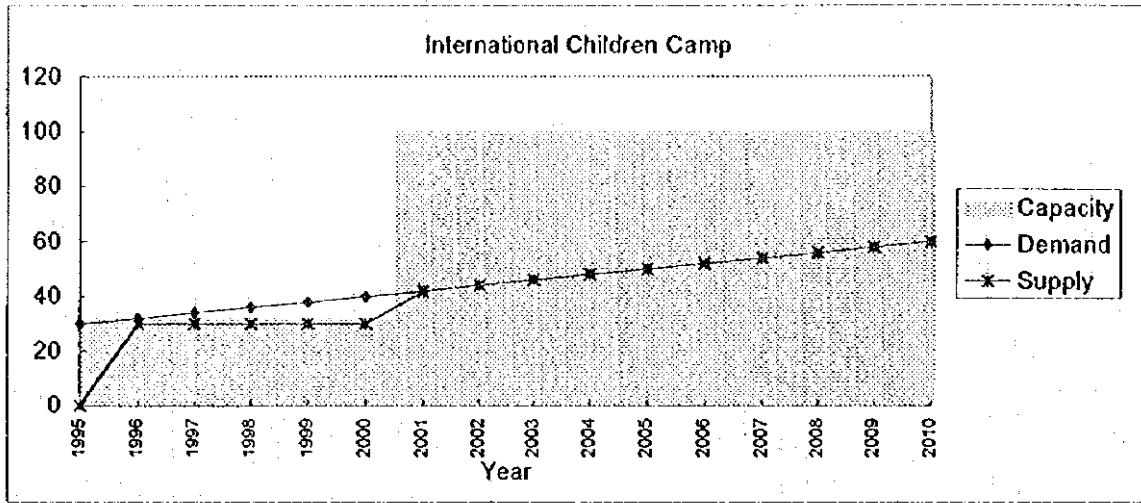

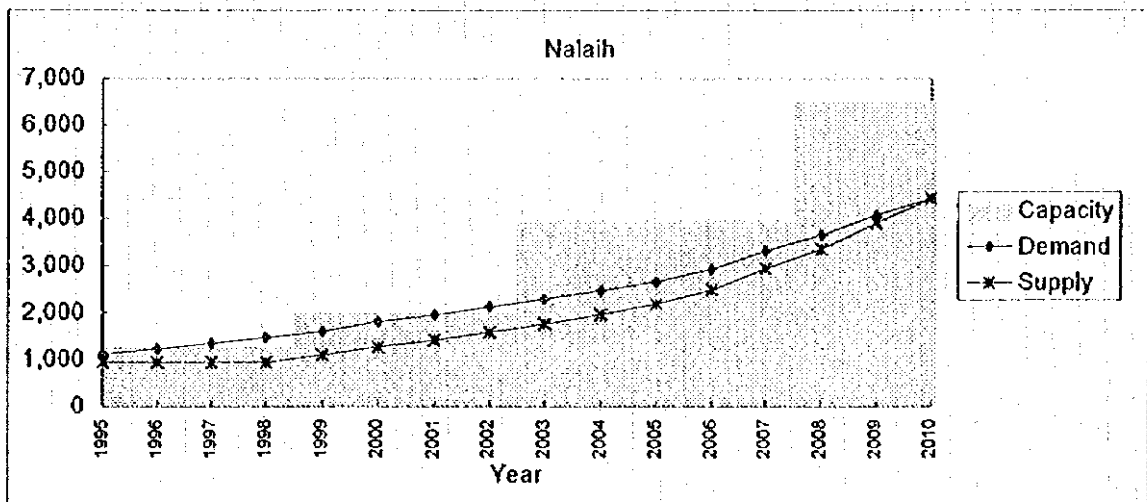
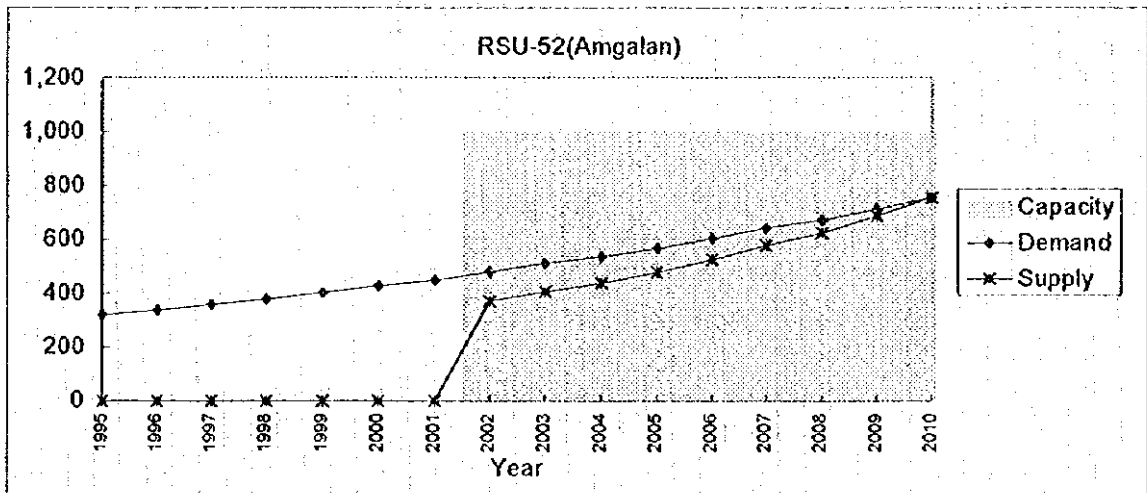
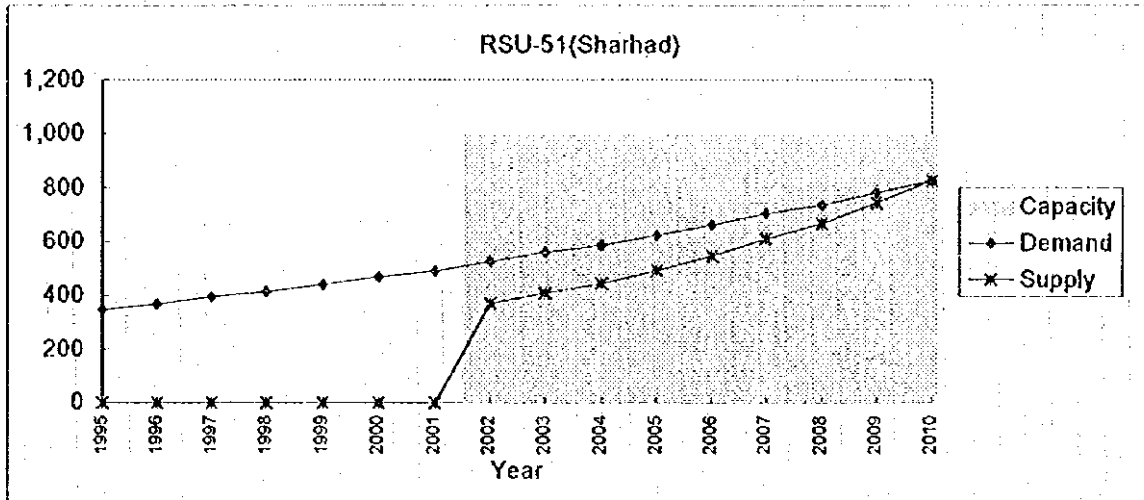

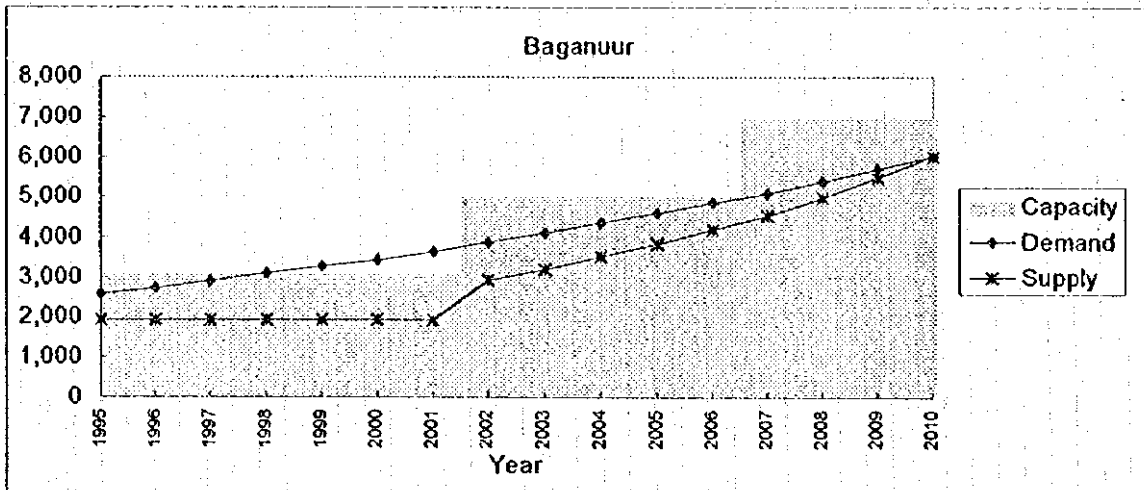
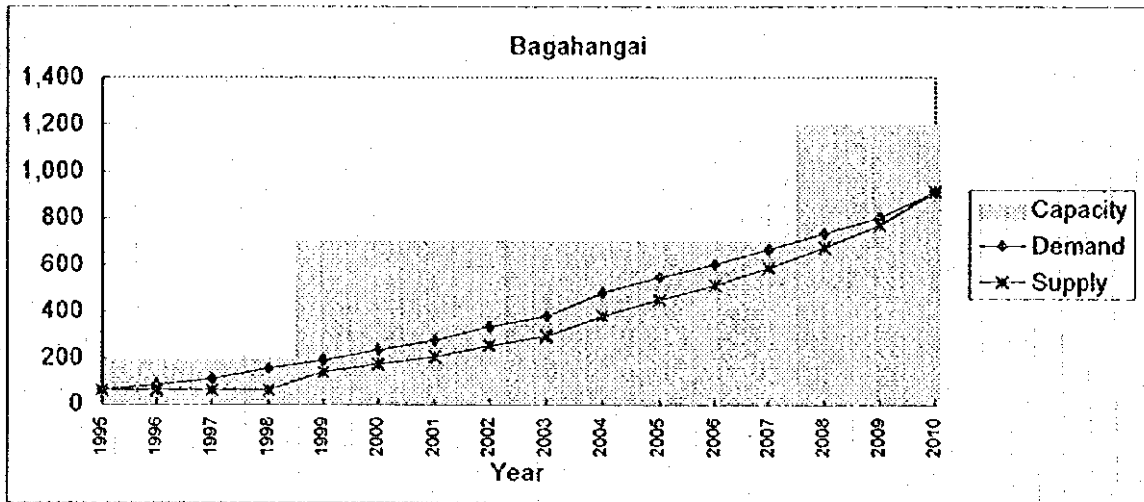

5 The Changes of Switching Capacity

Table 5-5-1 The Changes of Switching Capacity (1/4)

Unit Name	Year	1995		1996		1997		1998		1999	
		Capacity	Install	Total	Install	Total	Install	Total	Install	Total	
H02A		0		0		0		0		0	
	R21A	0		0		0		0		0	
	RJAA	0		0		0		0		0	
	RICA	0		0		0		0		0	
	Total	0	0	0	0	0	0	0	0	0	0
H03A		14,336		14,336		14,336		14,336		14,336	
	R02A	4,864		4,864		4,864		4,864		4,864	
	R04A	3,328		3,328		3,328		3,328		3,328	
	R05A	1,024		1,024		1,024		1,024		1,024	
	R06A	11,000		11,000		11,000		0		0	
	R37A	512		512		512		512		3,012	
	R37B	512		512		512		512		2,012	
	R38A	4,608		4,608		4,608		4,608		4,608	
	Sub Total	40,184	0	40,184	0	40,184	0	29,184	0	37,184	
H03B		0		0		0		0		0	
	RBIA	0		0		0		0		0	
	RSFA	0		0		0		0		0	
	Sub Total	0	0	0	0	0	0	0	0	0	
S03		4,800		4,800		0		0		0	
	Total	44,984	0	44,984	0	40,184	0	29,184	0	37,184	
H04A		0		0		0		0		0	
H05A		0		0	8,500	8,500		8,500	3,000	11,500	
	R51A	0		0		0		0		0	
	R52A	0		0		0		0		0	
	RGAA	0		0		0		0		0	
	RHOA	0		0		0		0		0	
	Sub Total	0	0	0	8,500	8,500	0	8,500	3,000	11,500	
S05		8,000		8,000		0		0		0	
	Total	8,000	0	8,000	8,500	8,500	0	8,500	3,000	11,500	
H06A		0		0		0	16,000	16,000		16,000	
H06B		0		0		0		0		0	
	Total	0	0	0	0	0	16,000	16,000	0	16,000	
H07A		0		0		0		0	6,000	6,000	
SNA		1,200		1,200		1,200		1,200		0	
PNA		48		48		48		48		0	
HNAA		0		0		0		0	2,000	2,000	
	RBHA	0		0		0		0	700	700	
	Sub Total	0	0	0	0	0	0	0	2,700	2,700	
	Total	1,248	0	1,248	0	1,248	0	1,248	2,700	2,700	
XBN		3,000		3,000		3,000		3,000		3,000	
PBN1		32		32		32		32		32	
PBN2		48		48		48		48		48	
HBNA		0		0		0		0		0	
	Total	3,080	0	3,080	0	3,080	0	3,080	0	3,080	
XJA		200		200		200		200		200	
XHO		50		50		50		50		50	
XGA		50		50		50		50		50	
XBI		200		200		200		200		200	
PSF		100		100		100		100		100	
PIC		32		32		32		32		32	
XBH		200		200		200		200		0	
	Grand Total	58,144	0	58,144	8,500	53,844	16,000	58,844	11,700	77,096	

Table 5-5-1 The Changes of Switching Capacity (2/4)

Unit Name	Year	2000		2001		2002		2003	
		Install	Total	Install	Total	Install	Total	Install	Total
H02A			0	20,000	20,000		20,000		20,000
	R21A		0	1,500	1,500		1,500		1,500
	RJAA		0	100	100		100	0	100
	RICA		0	100	100	0	100		100
	Total	0	0	21,700	21,700	0	21,700	0	21,700
H03A			14,336		14,336		14,336		14,336
	R02A		4,864		0		0		0
	R04A		7,328		7,328		7,328		7,328
	R05A		1,024		1,024		1,024		1,024
	R06A		0		0		0		0
	R37A		3,012		3,012		3,012		3,012
	R37B		2,012		2,012		2,012		2,012
	R38A		4,608		0		0		0
	Sub Total	0	37,184	0	27,712	0	27,712	0	27,712
H03B		13,000	13,000		13,000		13,000		13,000
	RBIA	500	500		500		500		500
	RSFA	300	300		300		300		300
	Sub Total	13,800	13,800	0	13,800	0	13,800	0	13,800
S03			0		0		0		0
	Total	13,800	50,984	0	41,512	0	41,512	0	41,512
H04A			0		0		0		0
H05A		0	11,500		11,500	4,000	15,500		15,500
	R51A		0		0	1,000	1,000		1,000
	R52A		0		0	1,000	1,000		1,000
	RGAA		0		0	100	100	0	100
	RHOA	0	0		0	100	100		100
	Sub Total	0	11,500	0	11,500	6,200	17,700	0	17,700
S05			0		0		0		0
	Total	0	11,500	0	11,500	6,200	17,700	0	17,700
H06A			16,000		16,000		16,000	11,000	27,000
H06B			0		0		0		0
	Total	0	16,000	0	16,000	0	16,000	11,000	27,000
H07A		0	6,000		6,000		6,000		6,000
SNA			0		0		0		0
PNA			0		0		0		0
HNAA			2,000		2,000		2,000	2,000	4,000
	RBHA		700		700	0	700		700
	Sub Total	0	2,700	0	2,700	0	2,700	2,000	4,700
	Total	0	2,700	0	2,700	0	2,700	2,000	4,700
XBN			3,000		3,000		0		0
PBN1			32		32		0		0
PBN2			48		48		0		0
HBNA			0		0	5,000	5,000		5,000
	Total	0	3,080	0	3,080	5,000	5,000	0	5,000
XJA			200		0		0		0
XHO			50		50		0		0
XGA			50		50		0		0
XBI			0		0		0		0
PSF			0		0		0		0
PIC			32		0		0		0
XBH			0		0		0		0
	Grand Total	13,800	90,596	21,700	102,592	11,200	110,612	13,000	123,612

Table 5-5-1 The Changes of Switching Capacity (3/4)

Unit Name	Year	2004		2005		2006		2007	
		Install	Total	Install	Total	Install	Total	Install	Total
H02A			20,000	0	20,000	11,000	31,000		31,000
	R21A		1,500	0	1,500	500	2,000		2,000
	RJAA		100		100		100		100
	RICA		100		100		100		100
	Total	0	21,700	0	21,700	11,500	33,200	0	33,200
H03A			14,336		14,336		14,336		14,336
	R02A		0		0		0		0
	R04A		7,328		0		0		0
	R05A		1,024		1,024		1,024		0
	R06A		0		0		0		0
	R37A		3,012		3,012		3,012		3,012
	R37B		2,012		2,012		2,012		2,012
	R38A		0		0		0		0
	Sub Total	0	27,712	0	20,384	0	20,384	0	19,360
H03B		10,000	23,000		23,000		23,000		23,000
	RBIA		500		500		500		500
	RSFA	100	400		400		400		400
	Sub Total	10,100	23,900	0	23,900	0	23,900	0	23,900
S03			0		0		0		0
	Total	10,100	51,612	0	44,284	0	44,284	0	43,260
H04A			0	11,000	11,000	0	11,000		11,000
H05A			15,500		15,500		15,500	11,000	26,500
	R51A		1,000		1,000		1,000		1,000
	R52A		1,000		1,000		1,000		1,000
	RGAA		100		100		100		100
	RHOA		100		100		100	100	200
	Sub Total	0	17,700	0	17,700	0	17,700	11,100	28,800
S05			0		0		0		0
	Total	0	17,700	0	17,700	0	17,700	11,100	28,800
H06A			27,000		27,000		27,000		27,000
H06B			0		0		0		0
	Total	0	27,000	0	27,000	0	27,000	0	27,000
H07A			6,000	4,000	10,000		10,000		10,000
	SNA		0		0		0		0
	PNA		0		0		0		0
	HNAA		4,000		4,000		4,000		4,000
	RBHA		700		700		700	0	700
	Sub Total	0	4,700	0	4,700	0	4,700	0	4,700
	Total	0	4,700	0	4,700	0	4,700	0	4,700
XBN			0		0		0		0
PBN1			0		0		0		0
PBN2			0		0		0		0
HBNA			5,000		5,000		5,000	2,000	7,000
	Total	0	5,000	0	5,000	0	5,000	2,000	7,000
XJA			0		0		0		0
XHO			0		0		0		0
XGA			0		0		0		0
XBI			0		0		0		0
PSF			0		0		0		0
PIC			0		0		0		0
XBH			0		0		0		0
Grand Total		10,100	133,712	15,000	141,384	11,500	152,884	13,100	164,960

Table 5-5-1 The Changes of Switching Capacity (4/4)

Unit Name	Year	2008		2009		2010		Total	
		Install	Total	Install	Total	Install	Total	Install	Total
H02A			31,000		31,000		31,000	31,000	31,000
	R21A		2,000		2,000		2,000	2,000	2,000
	RJAA		100		100		100	100	100
	RICA		100		100		100	100	100
	Total	0	33,200	0	33,200	0	33,200	33,200	33,200
H03A			14,336		14,336		14,336	0	14,336
	R02A		0		0		0	0	0
	R04A		0		0		0	0	0
	R05A		0		0		0	0	0
	R06A		0		0		0	0	0
	R37A		3,012		3,012		3,012	0	3,012
	R37B		2,012		2,012		2,012	0	2,012
	R38A		0		0		0	0	0
	Sub Total	0	19,360	0	19,360	0	19,360	0	19,360
H03B			23,000	12,000	35,000		35,000	35,000	35,000
	RBIA		500	200	700	0	700	700	700
	RSFA		400	100	500		500	500	500
	Sub Total	0	23,900	12,300	36,200	0	36,200	36,200	36,200
S03			0		0		0	0	0
	Total	0	43,260	12,300	55,560	0	55,560	36,200	55,560
H04A			11,000		11,000	4,000	15,000	15,000	15,000
H05A			26,500		26,500		26,500	18,000	26,500
	R51A		1,000		1,000		1,000	1,000	1,000
	R52A		1,000		1,000		1,000	1,000	1,000
	RGAA		100		100		100	100	100
	RHOA	0	200		200		200	200	200
	Sub Total	0	28,800	0	28,800	0	28,800	20,300	28,800
S05			0		0		0	0	0
	Total	0	28,800	0	28,800	0	28,800	20,300	28,800
H06A		8,000	35,000		35,000		35,000	35,000	35,000
H06B		5,000	5,000		5,000		5,000	5,000	5,000
	Total	13,000	40,000	0	40,000	0	40,000	40,000	40,000
H07A			10,000		10,000	4,000	14,000	14,000	14,000
SNA			0		0		0	0	0
PNA			0		0		0	0	0
HNAA		2,500	6,500		6,500		6,500	6,500	6,500
	RBHA	500	1,200		1,200		1,200	1,200	1,200
	Sub Total	3,000	7,700	0	7,700	0	7,700	7,700	7,700
	Total	3,000	7,700	0	7,700	0	7,700	7,700	7,700
XBN			0		0		0	0	0
PBN1			0		0		0	0	0
PBN2			0		0		0	0	0
HBNA			7,000		7,000		7,000	7,000	7,000
	Total	0	7,000	0	7,000	0	7,000	7,000	7,000
XJA			0		0		0	0	0
XHO			0		0		0	0	0
XGA			0		0		0	0	0
XBI			0		0		0	0	0
PSF			0		0		0	0	0
PIC			0		0		0	0	0
XBH			0		0		0	0	0
	Grand Total	16,000	180,960	12,300	193,260	8,000	201,260	173,400	201,260

CHAPTER 6

**DATA ON REVENUE ESTIMATE FOR BASIC PLAN
AND BAYANGOL ATC-6 PROJECT**

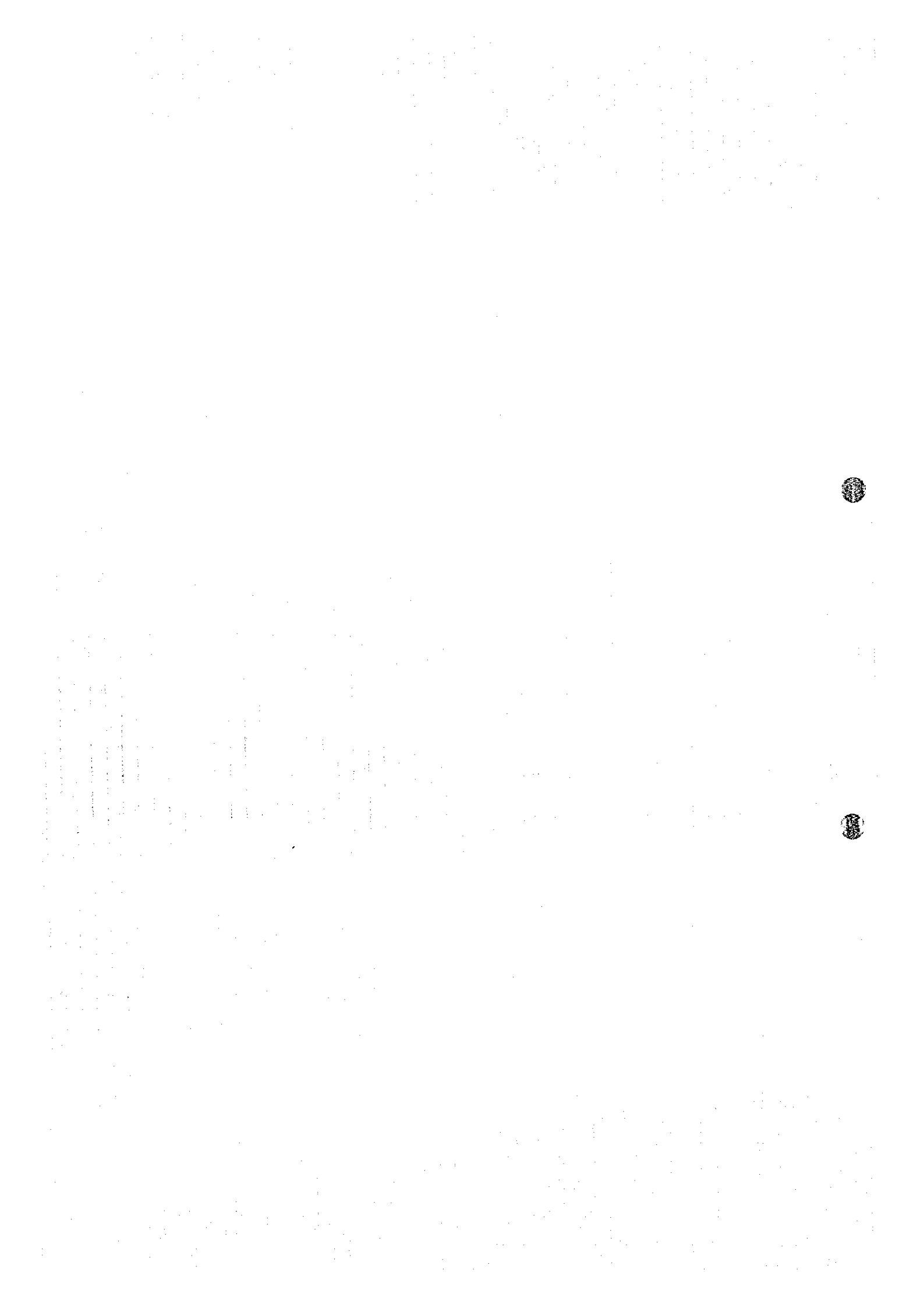

Table 6-1-1 Local Call Revenue Corresponding to Incremental Investment for Basic Plan

Item	Investment Year														
	1995	1996	1997	1998	1999	2000	2001	2002	2003	2004	2005	2006	2007	2008	2009
1) Min./sub/year business	8,760	9,016	9,271	9,527	9,892	10,111	10,330	10,549	10,914	11,133	11,352	11,571	11,899	12,118	12,337
residential	5,840	5,950	6,205	6,315	6,680	6,799	6,799	7,045	7,154	7,373	7,483	7,702	7,811	8,030	8,249
2) Traffic charged as part of rental business	1,800	1,800	1,800	1,800	1,800	1,800	1,800	1,800	1,800	1,800	1,800	1,800	1,800	1,800	1,800
3) Chargeable traffic (min/sub/year) business	6,960	7,216	7,471	7,727	8,092	8,311	8,530	8,749	9,114	9,333	9,552	9,771	10,099	10,318	10,537
residential	4,040	4,150	4,405	4,515	4,770	4,880	4,989	5,245	5,354	5,573	5,683	5,902	6,011	6,230	6,449
4) No. of subscribers (cumulative) business	13,797	14,739	15,549	16,405	17,356	18,398	19,501	20,671	21,912	23,226	24,620	26,097	27,663	29,323	31,082
residential	30,285	30,843	31,718	36,947	42,081	47,126	52,117	57,607	63,646	70,289	77,592	86,192	95,697	106,199	117,801
5) No. of subscribers (incremental) business	942	810	856	856	951	1,042	1,103	1,170	1,241	1,314	1,394	1,477	1,566	1,660	1,759
residential	558	875	875	5,229	5,134	5,045	4,991	5,490	6,039	6,643	7,303	8,000	9,505	10,502	11,602
6) Total incremental chargeable traffic (million Min/year) business	6.8	6.1	6.6	6.6	7.7	8.7	9.4	10.2	11.3	12.3	13.3	14.4	15.8	17.1	18.5
residential	2.3	3.9	3.9	23.6	24.5	24.6	24.9	28.8	32.3	37.0	41.5	50.8	57.1	65.4	74.8
total	9.1	9.9	9.9	30.2	32.2	33.3	34.3	39.0	43.6	49.3	54.8	65.2	72.9	82.6	93.4
7) Incremental Call revenue total (million Tg) total (million US\$)	0	27	30	91	97	100	103	117	131	148	164	196	219	248	280
	0.000	0.056	0.061	0.185	0.197	0.204	0.210	0.239	0.267	0.302	0.336	0.399	0.447	0.505	0.572

Item	Year					
	2010	2011	2012	2013	2014	2015
1) Min./sub/year business	12,556	12,556	12,556	12,556	12,556	12,556
residential	8,359	8,359	8,359	8,359	8,359	8,359
2) Traffic charged as part of rental business	1,800	1,800	1,800	1,800	1,800	1,800
3) Chargeable traffic (min/sub/year) business	10,756	10,756	10,756	10,756	10,756	10,756
residential	6,559	6,559	6,559	6,559	6,559	6,559
4) No. of subscribers (cumulative) business	32,947	34,923	37,018	39,238	41,592	44,090
residential	130,615	138,262	146,372	154,975	164,105	173,791
5) No. of subscribers (incremental) business	1,865	1,976	2,095	2,220	2,354	2,498
residential	12,814	7,647	8,110	8,603	9,130	9,686
6) Total incremental chargeable traffic (million Min/year) business	20.1	21.3	22.5	23.9	25.3	26.9
residential	84.0	50.2	53.2	56.4	59.9	63.5
total	104.1	71.4	75.7	80.3	85.2	90.4
7) Incremental Call revenue total (million Tg) total (million US\$)	312	214	227	241	256	271
	0.637	0.437	0.464	0.492	0.522	0.553

Call charge : 3 Tg / minute beyond 150 minutes per month
Exchange rate : 490 Tg/US\$

Table 6-1-2 Long-distance Call Revenue Corresponding to Incremental Investment for the Basic Plan

long distance call revenue per subscriber :

11,050 Tg/subscriber/year as of end 1995

Item	Investment Year														
	1995	1996	1997	1998	1999	2000	2001	2002	2003	2004	2005	2006	2007	2008	2009
Annual growth rate (%/year)	0.00	7.23	8.66	-5.97	7.90	6.25	6.39	7.52	6.62	7.37	6.06	7.25	6.29	6.99	7.07
Unit call revenue (Tg/sub)	11,050	11,849	12,875	13,644	14,722	15,642	16,641	17,893	19,077	20,483	21,724	23,299	24,765	26,496	28,369
Number of subscriber (Cumul)															
Ulaanbaatar	41,152	42,652	44,337	50,422	56,361	62,268	69,218	73,516	80,207	87,661	95,753	105,085	115,295	126,503	138,717
B-N-BH	2,950	2,950	2,930	2,930	3,076	3,256	3,400	4,762	5,251	5,854	6,459	7,204	8,065	9,019	10,166
total	44,082	45,582	47,267	53,352	59,437	65,524	71,618	78,278	85,558	93,515	102,212	112,289	123,360	135,522	148,883
Number of subscriber (Incremental)															
Ulaanbaatar	1,500	1,500	1,685	6,085	5,939	5,907	5,950	5,298	6,791	7,354	8,092	9,332	10,210	11,208	12,214
B-N-BH	0	0	0	0	146	180	144	1,362	489	603	605	745	861	954	1,147
total	1,500	1,500	1,685	6,085	6,085	6,087	6,094	6,660	7,280	7,957	8,697	10,077	11,071	12,162	13,361
Incremental Long distance call revenue (million Tg)															
(million US\$)		0.036	0.044	0.169	0.183	0.194	0.207	0.243	0.283	0.333	0.386	0.479	0.560	0.658	0.774

Item	Investment Year					
	2010	2011	2012	2013	2014	2015
Annual growth rate (%/year)	5.77	0.14	0.00	0.00	0.00	0.00
Unit call revenue (Tg/sub)	30,006	30,048	30,048	30,048	30,048	30,048
Number of subscriber (Cumul)						
Ulaanbaatar	152,206	160,918	170,125	179,867	190,163	201,048
B-N-BH	11,556	12,267	13,261	14,346	15,534	16,833
total	163,562	173,185	183,390	194,213	205,697	217,881
Number of subscriber (Incremental)						
Ulaanbaatar	13,489	8,712	9,211	9,738	10,296	10,885
B-N-BH	1,190	911	994	1,085	1,183	1,299
total	14,679	9,623	10,205	10,823	11,484	12,184
Incremental Long distance call revenue (million Tg)	440	299	307	325	345	366
(million US\$)	0.899	0.590	0.626	0.664	0.704	0.747

Exchange rate : 490 Tg/US\$

Table 6-1-3 International Call Revenue Corresponding to Incremental Investment for the Basic Plan

International call revenue per subscriber : 43,100 Tg/subscriber/year as of 1995

43,100 Tg/subscriber/year as of 1995

Item	Investment Year														
	1995	1996	1997	1998	1999	2000	2001	2002	2003	2004	2005	2006	2007	2008	2009
Annual rate of change in traffic generation(%/year)	0.00	4.64	6.07	3.39	5.31	3.66	3.80	4.93	4.03	4.78	3.47	4.66	3.70	4.40	4.43
Change in tariff level (%)	0.00	-13.00	0.00	-8.00	0.00	0.00	0.00	0.00	0.00	0.00	0.00	0.00	0.00	0.00	0.00
Unit call revenue (Tg/sub)	43,100	39,497	41,894	39,959	42,081	43,621	45,278	47,511	49,425	51,788	53,585	56,082	58,157	60,716	63,436
Number of subscriber (cumulative)	44,082	45,582	47,267	53,352	59,437	65,524	71,618	78,278	85,558	93,515	102,212	112,289	123,360	135,522	148,883
Number of subscriber (incremental)		1,500	1,685	6,085	6,085	6,087	6,094	6,660	7,280	7,957	8,697	10,077	11,071	12,162	13,361
International call revenue (million Tg)		59	71	243	256	266	276	316	360	412	466	565	644	738	848
(million US\$)		0.121	0.144	0.496	0.523	0.542	0.563	0.646	0.734	0.841	0.951	1.153	1.314	1.507	1.730

Item	Investment Year					
	2010	2011	2012	2013	2014	2015
Annual rate of change in traffic generation(%/year)	3.18	0.14	0.00	0.00	0.00	0.00
Change in tariff level (%)	0.00	0.00	0.00	0.00	0.00	0.00
Unit call revenue (Tg/sub)	65,453	65,545	65,545	65,545	65,545	65,545
Number of subscriber (cumulative)	163,562	173,185	183,390	194,213	205,697	217,881
Number of subscriber (incremental)	14,679	9,623	10,205	10,823	11,484	12,184
International call revenue (million Tg)	961	631	669	709	753	799
(million US\$)	1,961	1,287	1,365	1,448	1,536	1,630

Exchange rate : 490 Tg/US\$

Table 6-1-4 Rental Revenue Corresponding to Incremental Investment for the Basic Plan

Item	Investment Year															
	1995	1996	1997	1998	1999	2000	2001	2002	2003	2004	2005	2006	2007	2008	2009	
Number of subscribers (cumulative)	non-budgetary	8,278	8,843	9,329	9,843	10,414	11,039	11,701	12,403	13,147	13,936	14,772	15,658	16,598	17,594	18,649
	budgetary	5,519	5,896	6,220	6,562	6,942	7,359	7,800	8,268	8,765	9,290	9,848	10,439	11,065	11,729	12,433
	residential	30,285	30,843	31,718	36,947	42,081	47,126	52,117	57,607	63,646	70,289	77,592	86,192	95,697	106,199	117,801
Number of subscribers (incremental)	non-budgetary		565	486	514	571	625	662	702	745	788	836	886	940	996	1,055
	budgetary		377	324	342	380	417	441	468	496	526	558	591	626	664	704
	residential		558	875	5,229	5,134	5,045	4,991	5,490	6,039	6,643	7,303	8,000	9,505	10,502	11,602
Rental fee revenue (million Tg)	non-budgetary		44.8	38.5	40.7	45.2	49.5	52.4	55.6	59.0	62.4	66.2	70.2	74.4	78.9	83.6
	budgetary		17.6	15.2	16.0	16.0	17.8	20.6	21.9	23.2	24.6	26.1	27.6	29.3	31.1	32.9
	residential		2.8	4.4	26.4	25.9	25.4	25.2	27.7	30.4	33.5	36.8	43.3	47.9	52.9	58.5
Total (million US\$)		0.133	0.118	0.170	0.181	0.193	0.200	0.215	0.230	0.246	0.264	0.288	0.309	0.332	0.357	

Item	Investment Year						
	2010	2011	2012	2013	2014	2015	
Number of subscribers (cumulative)	non-budgetary	19,768	20,954	22,211	23,543	24,955	26,454
	budgetary	13,179	13,969	14,807	15,695	16,637	17,636
	residential	130,615	138,262	146,372	154,975	164,105	173,791
Number of subscribers (incremental)	non-budgetary	1,119	1,186	1,257	1,332	1,412	1,499
	budgetary	746	790	838	888	942	999
	residential	12,814	7,647	8,110	8,603	9,130	9,686
Rental fee revenue (million Tg)	non-budgetary	88.6	93.9	99.6	105.5	111.9	118.7
	budgetary	34.9	37.0	39.2	41.6	44.1	46.8
	residential	64.6	38.5	40.9	43.4	46.0	48.8
Total (million US\$)	0.384	0.346	0.367	0.389	0.412	0.437	

(Rental fee)
 non-budgetary (business) : 6,600 Tg/month
 budgetary : 3,900 Tg/month
 residential : 420 Tg/month
 (Proportion of :)
 non-budgetary (business) : 60%
 budgetary : 40%

Exchange rate : 490 Tg/US\$

Table 6-1-5 Summary of All Revenue Corresponding to Investment Year for the Basic Plan

(Unit : million US\$)

Item	Investment Year														
	1995	1996	1997	1998	1999	2000	2001	2002	2003	2004	2005	2006	2007	2008	2009
1) Call revenue	0.000	0.056	0.061	0.185	0.197	0.204	0.210	0.239	0.267	0.302	0.336	0.399	0.447	0.505	0.572
Local call	0.000	0.036	0.044	0.169	0.183	0.194	0.207	0.243	0.283	0.333	0.386	0.479	0.560	0.658	0.774
Long distance call	0.000	0.121	0.144	0.496	0.523	0.542	0.563	0.646	0.734	0.841	0.951	1.153	1.314	1.507	1.730
International call	0.000	0.213	0.249	0.851	0.902	0.940	0.980	1.128	1.285	1.475	1.672	2.032	2.320	2.670	3.075
Total	0.000	0.133	0.118	0.170	0.181	0.193	0.200	0.215	0.230	0.246	0.264	0.288	0.309	0.332	0.357
2) Rental revenue	0.000	0.046	0.040	0.042	0.047	0.051	0.054	0.057	0.061	0.064	0.068	0.072	0.077	0.081	0.086
Installation charge revenue	0.000	0.027	0.043	0.256	0.251	0.247	0.244	0.269	0.296	0.325	0.358	0.421	0.466	0.514	0.568
business	0.000	0.073	0.083	0.298	0.298	0.298	0.298	0.326	0.357	0.390	0.426	0.494	0.542	0.596	0.654
residential	0.000	0.031	0.033	0.092	0.098	0.102	0.106	0.121	0.136	0.155	0.174	0.209	0.237	0.270	0.309
total	0.000	0.377	0.401	1.112	1.181	1.235	1.237	1.463	1.651	1.876	2.110	2.528	2.866	3.273	3.741
4) Other revenue	0.000	0.000	0.000	0.000	0.000	0.000	0.000	0.000	0.000	0.000	0.000	0.000	0.000	0.000	0.000
TOTAL	0.000	0.533	0.519	1.283	1.368	1.428	1.437	1.670	1.902	2.152	2.374	2.816	3.175	3.605	4.096

Item	Investment Year					
	2010	2011	2012	2013	2014	2015
1) Call revenue	0.637	0.437	0.464	0.492	0.522	0.553
Local call	0.899	0.590	0.626	0.664	0.704	0.747
Long distance call	1.961	1.287	1.365	1.448	1.536	1.630
International call	3.497	2.315	2.454	2.603	2.762	2.930
Total	0.384	0.346	0.367	0.389	0.412	0.437
2) Rental revenue	0.091	0.097	0.103	0.109	0.115	0.122
Installation charge revenue	0.628	0.375	0.397	0.421	0.447	0.474
business	0.719	0.471	0.500	0.530	0.562	0.597
residential	0.349	0.239	0.254	0.269	0.286	0.303
total	4.230	2.900	3.075	3.261	3.460	3.671
4) Other revenue	0.000	0.000	0.000	0.000	0.000	0.000
TOTAL	0.000	0.000	0.000	0.000	0.000	0.000

Proportion of other revenue to the sum of call revenue and rental revenue : 9.00%
 Installation charge : 490 Tg/CSS
 business : 24,000 tg
 resident : 12,000 tg
 Exchange rate :

Table 6-1-6 Summary of All Revenues on an Annual Basis for the Basic Plan

		1999	2000	2001	2002	2003	2004	2005	2006	2007	2008	2009	2010	2011	2012	2013	2014	2015	2016	2017	2018
(Unit : million US\$)																					
1)	Call revenue	0.197	0.401	0.611	0.830	1.117	1.419	1.754	2.153	2.600	3.105	3.677	4.314	4.752	5.215	5.707	6.228	6.782	6.782	6.782	6.782
	Local call	0.183	0.377	0.584	0.827	1.111	1.443	1.829	2.308	2.868	3.525	4.299	5.198	5.788	6.414	7.077	7.782	8.529	8.529	8.529	8.529
	Long distance call	0.523	1.064	1.628	2.273	3.008	3.849	4.800	5.953	7.267	8.774	10.504	12.465	13.752	15.117	16.565	18.101	19.730	19.730	19.730	19.730
	International call	0.902	1.842	2.823	3.950	5.235	6.711	8.383	10.414	12.735	15.405	18.480	21.977	24.291	26.746	29.349	32.111	35.041	35.041	35.041	35.041
	Total	0.181	0.374	0.575	0.789	1.019	1.265	1.529	1.817	2.126	2.459	2.816	3.200	3.545	3.912	4.301	4.713	5.150	5.150	5.150	5.150
2)	Rental revenue	0.098	0.199	0.306	0.427	0.563	0.718	0.892	1.101	1.337	1.608	1.917	2.266	2.505	2.759	3.028	3.314	3.617	3.617	3.617	3.617
3)	Other revenue	1.181	2.416	3.703	5.166	6.817	8.693	10.804	13.332	16.198	19.471	23.212	27.442	30.342	33.417	36.678	40.138	43.808	43.808	43.808	43.808
	sub-total	0.298	0.298	0.298	0.326	0.357	0.390	0.426	0.494	0.542	0.596	0.654	0.719	0.471	0.500	0.530	0.562	0.597	0.000	0.000	0.000
4)	Installation charge revenue	1.479	2.714	4.001	5.492	7.174	9.083	11.230	13.826	16.741	20.067	23.866	28.161	30.813	33.917	37.208	40.700	44.405	43.808	43.808	43.808
	Total	6.782	8.529	19.730	19.730	19.730	19.730	19.730	19.730	19.730	19.730	19.730	19.730	19.730	19.730	19.730	19.730	19.730	19.730	19.730	19.730
(Unit : million US\$)																					
1)	Call revenue	6.782	6.782	6.782	6.782	6.782	6.585	6.381	6.171	5.932	5.665	5.363	5.028								
	Local call	8.529	8.529	8.529	8.529	8.529	8.346	8.152	7.945	7.701	7.418	7.085	6.700								
	Long distance call	19.730	19.730	19.730	19.730	19.730	19.208	18.666	18.103	17.457	16.723	15.882	14.931								
	International call	35.041	35.041	35.041	35.041	35.041	34.139	33.199	32.219	31.091	29.806	28.330	26.658								
	Total	5.150	5.150	5.150	5.150	5.150	4.969	4.776	4.576	4.361	4.131	3.885	3.622								
2)	Rental revenue	3.617	3.617	3.617	3.617	3.617	3.520	3.418	3.311	3.191	3.054	2.899	2.725								
3)	Other revenue	43.808	43.808	43.808	43.808	43.808	42.627	41.392	40.106	38.642	36.991	35.115	33.005								
	sub-total	0.000	0.000	0.000	0.000	0.000	0.000	0.000	0.000	0.000	0.000	0.000	0.000								
4)	Installation charge revenue	43.808	43.808	43.808	43.808	43.808	42.627	41.392	40.106	38.642	36.991	35.115	33.005								
	Total	43.808	43.808	43.808	43.808	43.808	43.808	43.808	43.808	43.808	43.808	43.808	43.808								

Table 6-1-7 Personnel and Non-personnel Expenditures for Each Investment for the Basic Plan

US\$ = 490 Tg

Item	1995	1996	1997	1998	1999	2000	2001	2002	2003	2004
(1) Personnel cost										
Cummulative No. of personnel for UB	1,351	1,366	1,382	1,397	1,413	1,428	1,443	1,459	1,474	1,490
MTC	22	22	22	22	22	22	22	22	22	22
MCAC	1,373	1,388	1,404	1,419	1,435	1,450	1,465	1,481	1,496	1,512
Total	15	15	15	15	15	15	15	15	15	15
Incremental No. of personnel for UB	0	0	0	0	0	0	0	0	0	0
MTC	0	0	0	0	0	0	0	0	0	0
MCAC	328,000	328,000	344,400	361,620	379,701	398,686	418,620	439,551	461,529	484,605
Total	5,000	5,000	5,000	5,000	5,000	5,000	5,000	5,000	5,000	5,000
Unit non-personnel cost (Tg/sub/year)	5051.2	5303.8	5568.9	5847.4	6139.8	6446.8	6769.1	7107.5	7462.9	7829.9
Rate of change in unit cost (%/year)	10.3	10.8	11.4	11.9	12.5	13.2	13.8	14.5	15.2	15.9
Incremental Personnel Cost (US\$ thousand)	24,000	24,000	24,432	24,872	25,319	25,775	26,239	26,711	27,192	27,682
Unit non-personnel cost (Tg/sub/year)	0	1,800	1,800	1,800	1,800	1,800	1,800	1,800	1,800	1,800
Rate of change in unit cost (%/year)	1,500	1,685	6,085	6,085	6,085	6,087	6,094	6,660	7,280	7,957
Number of incremental subscriber non-personnel cost (million Tg)	36	41	151	154	154	157	160	178	198	220
(million US\$)	0.073	0.084	0.309	0.314	0.314	0.320	0.326	0.363	0.404	0.450
(2) Non-personnel cost										
Cummulative No. of personnel for UB	1,521	1,536	1,552	1,567	1,583	1,583	1,583	1,583	1,583	1,583
MTC	22	22	22	22	22	22	22	22	22	22
MCAC	1,543	1,558	1,574	1,589	1,605	1,605	1,605	1,605	1,605	1,605
Total	16	16	16	16	16	16	16	16	16	16
Incremental No. of personnel for UB	0	0	0	0	0	0	0	0	0	0
MTC	0	0	0	0	0	0	0	0	0	0
MCAC	534,277	560,991	589,041	618,493	649,418	681,888	715,933	751,782	789,371	828,840
Total	5,000	5,000	5,000	5,000	5,000	5,000	5,000	5,000	5,000	5,000
Unit non-personnel cost	8334.7	8751.5	9189.0	9648.5	10130.9	10600.0	11080.0	11570.0	12070.0	12580.0
Rate of change in unit cost (%/year)	17.0	17.9	18.8	19.7	20.7	20.7	20.7	20.7	20.7	20.7
Incremental Personnel Cost (US\$ thousand)	28,687	29,204	29,729	30,264	30,809	31,364	31,928	32,503	33,088	33,684
Unit non-personnel cost (Tg/sub/year)	1,800	1,800	1,800	1,800	1,800	1,800	1,800	1,800	1,800	1,800
Rate of change in unit cost (%/year)	10,077	11,071	12,162	13,361	14,679	9,623	10,205	10,823	11,484	12,184
Number of incremental subscriber non-personnel cost (million Tg)	289	323	362	404	452	302	326	352	380	410
(million US\$)	0.590	0.660	0.738	0.825	0.923	0.616	0.665	0.718	0.775	0.838

Note: Personnel and non-personnel expenditures for respective year are those to be incurred by the investment in the previous year.

Table 6-1-8 Annual Personnel and Non-personnel Expenditures of the Basic Plan

(Unit: million US\$)

Item	1999	2000	2001	2002	2003	2004	2005	2006	2007	2008	2009	2010	2011	2012	2013	2014
Personnel cost	0.012	0.024	0.038	0.051	0.066	0.081	0.097	0.114	0.132	0.151	0.170	0.191	0.191	0.191	0.191	0.191
Non-personnel cost	0.314	0.635	0.961	1.324	1.728	2.178	2.678	3.268	3.927	4.665	5.491	6.414	7.029	7.694	8.412	9.188
Total	0.326	0.659	0.999	1.375	1.794	2.259	2.775	3.382	4.060	4.816	5.661	6.605	7.221	7.886	8.604	9.379

Item	2015	2016	2017	2018	2019	2020	2021	2022	2023	2024	2025	2026	2027	2028	2029	2030
Personnel cost	0.191	0.191	0.191	0.191	0.179	0.167	0.154	0.140	0.125	0.110	0.094	0.077	0.059	0.040	0.021	0.000
Non-personnel cost	10.025	10.025	10.025	10.025	9.711	9.391	9.064	8.701	8.297	7.845	7.345	6.758	6.098	5.360	4.535	3.612
Total	10.217	10.217	10.217	10.217	9.890	9.557	9.218	8.841	8.423	7.958	7.442	6.835	6.157	5.400	4.555	3.612

Note : Personnel and non-personnel expenditures for respective year are the sums of all the personnel and non-personnel expenditures for all the investments.

Table 6-1-9 Local Call Revenue of ATC-6 Project

Year	Unit call generation (minute/day/ subscriber)		Number of subscribers		Total call minutes (thousand minute/year)			Chargeable minute (thousand minute/year)	Call revenue	
	Business	Residential	Business	Residential	Business	Residential	Total		(million Tg)	(million US\$)
1999	27.1	18.0	2,173	11,501	21,494	75,562	97,056	97,054	291	0.594
2000	27.7	18.3	2,307	11,532	23,325	77,028	100,353	100,351	301	0.614
2001	28.3	18.6	2,414	11,731	24,935	79,642	104,577	104,575	314	0.640
2002	28.9	19.3	2,560	13,000	27,004	91,579	118,583	118,581	356	0.726
2003	29.9	19.6	2,575	13,425	28,098	96,045	124,143	124,141	372	0.760
2004	30.5	20.2	2,575	13,425	28,662	98,985	127,647	127,645	383	0.782
2005	31.1	20.5	2,575	13,425	29,226	100,455	129,681	129,679	389	0.794
2006	31.7	21.1	2,575	13,425	29,790	103,396	133,185	133,183	400	0.815
2007	32.6	21.4	2,575	13,425	30,635	104,866	135,501	135,499	406	0.830
2008	33.2	22.0	2,575	13,425	31,199	107,806	139,005	139,003	417	0.851
2009	33.8	22.6	2,575	13,425	31,763	110,746	142,509	142,507	428	0.872
2010	34.4	22.9	2,575	13,425	32,327	112,216	144,543	144,541	434	0.885
2011	34.4	22.9	2,575	13,425	32,327	112,216	144,543	144,541	434	0.885
2012	34.4	22.9	2,575	13,425	32,327	112,216	144,543	144,541	434	0.885
2013	34.4	22.9	2,575	13,425	32,327	112,216	144,543	144,541	434	0.885
2014	34.4	22.9	2,575	13,425	32,327	112,216	144,543	144,541	434	0.885
2015	34.4	22.9	2,575	13,425	32,327	112,216	144,543	144,541	434	0.885
2016	34.4	22.9	2,575	13,425	32,327	112,216	144,543	144,541	434	0.885
2017	34.4	22.9	2,575	13,425	32,327	112,216	144,543	144,541	434	0.885
2018	34.4	22.9	2,575	13,425	32,327	112,216	144,543	144,541	434	0.885
Total	34.4									

Local call charge : 3 Tg/minute
 Exchange rate : 490 Tg/US\$

Table 6-1-10 Long Distance Call Revenue of ATC-6 Project

long distance call revenue per subscriber : 11,050 Tg/subscriber/year as of end 1995

Item	1995	1996	1997	1998	1999	2000	2001	2002	2003	2004	2005	2006	2007	2008	2009
Annual growth rate (%/year)	0.00	7.23	8.66	5.97	7.90	6.25	6.39	7.52	6.62	7.37	6.06	7.25	6.29	6.99	7.07
Unit call revenue (Tg/sub)	11,050	11,849	12,875	13,644	14,722	15,642	16,641	17,993	19,077	20,483	21,724	23,299	24,765	26,496	28,369
Number of subscriber					12,274	13,839	14,145	15,560	16,000	16,000	16,000	16,000	16,000	16,000	16,000
Incremental Long distance call revenue (000 Tz)					181	216	235	278	305	328	348	373	396	424	454
(US\$)					0.369	0.442	0.480	0.568	0.623	0.669	0.709	0.761	0.809	0.865	0.926

Item	2010	2011	2012	2013	2014	2015	2016	2017	2018
Annual growth rate (%/year)	5.77	0.14	0.00	0.00	0.00	0.00	0.00	0.00	0.00
Unit call revenue (Tg/sub)	30,006	30,048	30,048	30,048	30,048	30,048	30,048	30,048	30,048
Number of subscriber	16,000	16,000	16,000	16,000	16,000	16,000	16,000	16,000	16,000
Incremental Long distance call revenue (000 Tz)	480	481	481	481	481	481	481	481	481
(US\$)	0.980	0.981	0.981	0.981	0.981	0.981	0.981	0.981	0.981

US\$ = 490 tuzriq

Table 6-1-11 International Call Revenue of AIC-6 Project

43.100 Tg/subscriber/year as of 1995

International call revenue per subscriber :

Item	1995	1996	1997	1998	1999	2000	2001	2002	2003	2004	2005	2006	2007	2008	2009
Annual rate of change in traffic generation(%/year)	0.00	4.64	6.07	3.38	5.31	3.66	3.80	4.93	4.03	4.78	3.47	4.66	3.70	4.40	4.48
Change in tariff level (%)	0.00	-13.00	0.00	-8.00	0.00	0.00	0.00	0.00	0.00	0.00	0.00	0.00	0.00	0.00	0.00
Unit call revenue (Tg/sub)	43.100	39,497	41,894	39,959	42,081	43,621	45,278	47,511	49,425	51,788	53,535	56,082	58,157	60,716	63,436
Number of subscriber					12,274	12,839	14,145	15,560	16,000	16,000	16,000	16,000	16,000	16,000	16,000
International call revenue (million Tg)					516	604	640	739	791	829	857	897	931	971	1,015
(million US\$)					1,054	1,232	1,307	1,509	1,614	1,691	1,750	1,831	1,899	1,983	2,071

Item	2010	2011	2012	2013	2014	2015	2016	2017	2018
Annual rate of change in traffic generation(%/year)	3.18	0.14	0.00	0.00	0.00	0.00	0.00	0.00	0.00
Change in tariff level (%)	0.00	0.00	0.00	0.00	0.00	0.00	0.00	0.00	0.00
Unit call revenue (Tg/sub)	65,453	65,545	65,545	65,545	65,545	65,545	65,545	65,545	65,545
Number of subscriber	16,000	16,000	16,000	16,000	16,000	16,000	16,000	16,000	16,000
International call revenue (million Tg)	1,047	1,049	1,049	1,049	1,049	1,049	1,049	1,049	1,049
(million US\$)	2,137	2,140	2,140	2,140	2,140	2,140	2,140	2,140	2,140

Table 6-1-12 Installation Charge Revenue of ATC-6 Project

Year	Number of total subscribers		Number of additional subscribers		Installation charge revenue			
	Business	Residential	Business	Residential	Business (thousand Tg)	Residential (thousand Tg)	Total	
							(thousand Tg)	(thousand US\$)
1999	2,173	10,101	1,239	5,761	29,743	69,129	98,871	201.8
2000	2,307	11,532	134	1,431	3,216	17,172	20,388	41.6
2001	2,414	11,731	107	199	2,568	2,388	4,956	10.1
2002	2,560	13,000	146	1,269	3,504	15,228	18,732	38.2
2003	2,575	13,425	15	425	360	5,100	5,460	11.1
2004	2,575	13,425	0	0	0	0	0	0.0
2005	2,575	13,425	0	0	0	0	0	0.0
2006	2,575	13,425	0	0	0	0	0	0.0
2007	2,575	13,425	0	0	0	0	0	0.0
2008	2,575	13,425	0	0	0	0	0	0.0
2009	2,575	13,425	0	0	0	0	0	0.0
2010	2,575	13,425	0	0	0	0	0	0.0
2011	2,575	13,425	0	0	0	0	0	0.0
2012	2,575	13,425	0	0	0	0	0	0.0
2013	2,575	13,425	0	0	0	0	0	0.0
2014	2,575	13,425	0	0	0	0	0	0.0
2015	2,575	13,425	0	0	0	0	0	0.0
2016	2,575	13,425	0	0	0	0	0	0.0
2017	2,575	13,425	0	0	0	0	0	0.0
2018	2,575	13,425	0	0	0	0	0	0.0
Total								

Assumptions :

Installation charge :

business : 24,000 tugrig

residential : 12,000 tugrig

Exchange rate : 490 tugrig/US\$

Notes : The numbers of new subscribers in 1999 are those to be newly connected by the ATC-6 project (7,000 in total). The numbers of those to be transferred from the old exchange are not included.

Table 6-1-13 Rental Charge Revenue of ATC-6 Project

Year	Number of total subscribers		Rental charge revenue			
	Business	Residential	Business (million Tg)	Residential (million Tg)	Total	
					(million Tg)	(million US\$)
1999	2,173	10,101	136.9	4.2	141.1	0.288
2000	2,307	11,532	145.3	4.8	150.2	0.306
2001	2,414	11,731	152.1	4.9	157.0	0.320
2002	2,560	13,000	161.3	5.5	166.7	0.340
2003	2,575	13,425	162.2	5.6	167.9	0.343
2004	2,575	13,425	162.2	5.6	167.9	0.343
2005	2,575	13,425	162.2	5.6	167.9	0.343
2006	2,575	13,425	162.2	5.6	167.9	0.343
2007	2,575	13,425	162.2	5.6	167.9	0.343
2008	2,575	13,425	162.2	5.6	167.9	0.343
2009	2,575	13,425	162.2	5.6	167.9	0.343
2010	2,575	13,425	162.2	5.6	167.9	0.343
2011	2,575	13,425	162.2	5.6	167.9	0.343
2012	2,575	13,425	162.2	5.6	167.9	0.343
2013	2,575	13,425	162.2	5.6	167.9	0.343
2014	2,575	13,425	162.2	5.6	167.9	0.343
2015	2,575	13,425	162.2	5.6	167.9	0.343
2016	2,575	13,425	162.2	5.6	167.9	0.343
2017	2,575	13,425	162.2	5.6	167.9	0.343
2018	2,575	13,425	162.2	5.6	167.9	0.343

Assumptions :

rental charge :

business : 5,250 tugrig/month *

residential : 420 tugrig/month

Exchange rate : 490 tugrig/US\$

* average of 6,600 tg for business and 3,900 tg for budgetary organizations. This average figure is used since the demand forecast did not disaggregate business demand into private business and budgetary organization.

Table 6-1-14 Personnel and Non-Personnel Expenditures of ATC-6 Project

Year	No. of Subscribers		Expenditures				Total (mln\$)
	No.	(%)	Non-personnel		Personnel		
			(mln Tg)	(mln\$)	(mln Tg)	(mln\$)	
1995	8,671	54.2	219.5	0.448	3.087	0.006	0.454
1996	8,768	54.8	222.0	0.453	3.121	0.006	0.459
1997	9,211	57.6	233.2	0.476	3.279	0.007	0.483
1998	10,946	68.4	277.1	0.566	3.896	0.008	0.574
1999	12,274	76.7	310.8	0.634	4.369	0.009	0.643
2000	13,839	86.5	350.4	0.715	4.926	0.010	0.725
2001	14,145	88.4	358.1	0.731	5.035	0.010	0.741
2002	15,560	97.3	394.0	0.804	5.539	0.011	0.815
2003	16,000	100.0	405.1	0.827	5.696	0.012	0.838
2004	16,000	100.0	405.1	0.827	5.696	0.012	0.838
2005	16,000	100.0	405.1	0.827	5.696	0.012	0.838
2006	16,000	100.0	405.1	0.827	5.696	0.012	0.838
2007	16,000	100.0	405.1	0.827	5.696	0.012	0.838
2008	16,000	100.0	405.1	0.827	5.696	0.012	0.838
2009	16,000	100.0	405.1	0.827	5.696	0.012	0.838
2010	16,000	100.0	405.1	0.827	5.696	0.012	0.838
2011	16,000	100.0	405.1	0.827	5.696	0.012	0.838
2012	16,000	100.0	405.1	0.827	5.696	0.012	0.838
2013	16,000	100.0	405.1	0.827	5.696	0.012	0.838
2014	16,000	100.0	405.1	0.827	5.696	0.012	0.838
2015	16,000	100.0	405.1	0.827	5.696	0.012	0.838
2016	16,000	100.0	405.1	0.827	5.696	0.012	0.838
2017	16,000	100.0	405.1	0.827	5.696	0.012	0.838
2018	16,000	100.0	405.1	0.827	5.696	0.012	0.838