

HIS MAJESTY'S GOVERNMENT OF NEPAL
 MINISTRY OF WORKS AND TRANSPORT
 DEPARTMENT OF ROADS

AFTERCARE STUDY
 FOR
 SINDHULI ROAD CONSTRUCTION PROJECT

PROFILE SECTION II-3 SHEET NO.
 B - 103

SCALE HOR. 1 : 2000 VER. 1 : 500 DATE

JAPAN INTERNATIONAL COOPERATION AGENCY

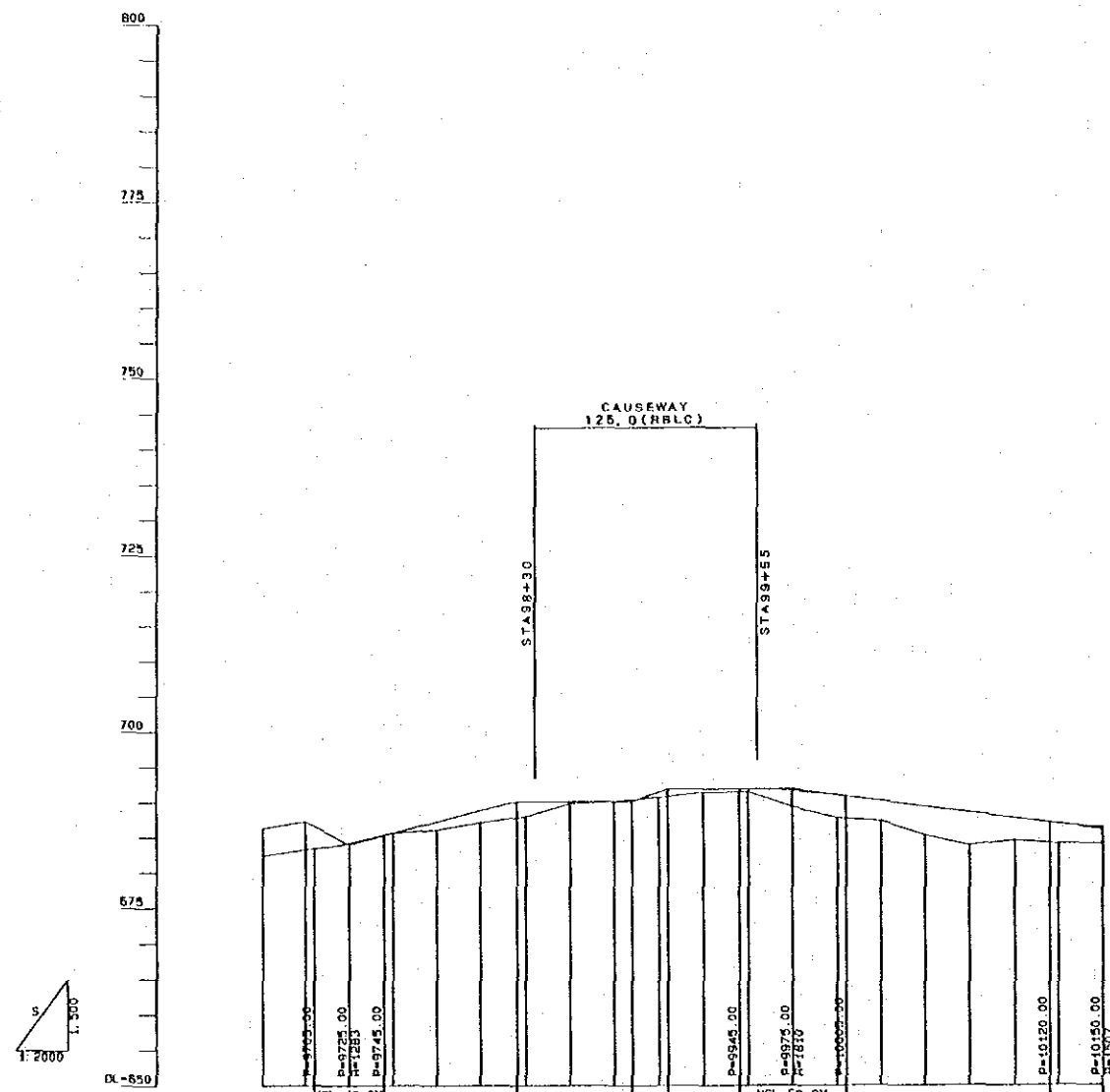

GRADE	PROPOSED HEIGHT	GROUND HEIGHT	CUTTING DEPTH	EMBANKMENT HEIGHT	ACCUMULATED DISTANCE	DISTANCE	STATION	CURVE ELEMENT
13.2000% 125.00M	682.40	686.30	3.90			25.00	96+75	L=71.01
684.00	683.20	687.20	4.00			25.00	97	L=32.34 R=200.00
684.15	683.90	685.90	0.26	0.26		25.00	97+25	L=32.15 R=200.00
685.89	685.50	685.50	0.08	0.08		25.00	97+50	L=32.15 R=200.00
687.15	686.50	686.00	1.16	1.16		25.00	97+75	L=32.15 R=200.00
688.74	687.00	687.00	1.74	1.74		25.00	98	L=32.15 R=200.00
LEVEL 65.00M 590.00	687.90	687.90	2.10	2.10		25.00	98+25	L=362.81
LEVEL 70.00M 591.80	689.00	689.70	0.30	0.30		25.00	98+50	
590.00	690.00	690.00	0.00	0.00		25.00	98+75	
591.35	690.60	690.60	0.75	0.75		25.00	99	
LEVEL 70.00M 591.80	691.30	691.30	0.50	0.50		25.00	99+25	
591.79	691.40	691.40	0.39	0.39		25.00	99+50	
591.85	692.30	692.30	2.25	2.25		25.00	99+75	
590.96	697.70	697.70	3.26	3.26		25.00	100	
590.14	697.30	697.30	2.84	2.84		25.00	100+25	
589.31	605.20	605.20	4.11	4.11		25.00	100+50	
588.49	683.60	683.60	4.69	4.69		25.00	100+75	
587.66	684.50	684.50	3.16	3.16		25.00	101	
586.84	684.00	684.00	2.84	2.84		25.00	101+25	
586.00	684.00	684.00	2.30	2.30		25.00	101+50	

HIS MAJESTY'S GOVERNMENT OF NEPAL
 MINISTRY OF WORKS AND TRANSPORT
 DEPARTMENT OF ROADS

AFTERCARE STUDY
 FOR
 SINDHULI ROAD CONSTRUCTION PROJECT

PROFILE SECTION II-3

SHEET NO.
 B - 104

SCALE HOR. 1: 2000 VER. 1: 500

DATE

JAPAN INTERNATIONAL COOPERATION AGENCY

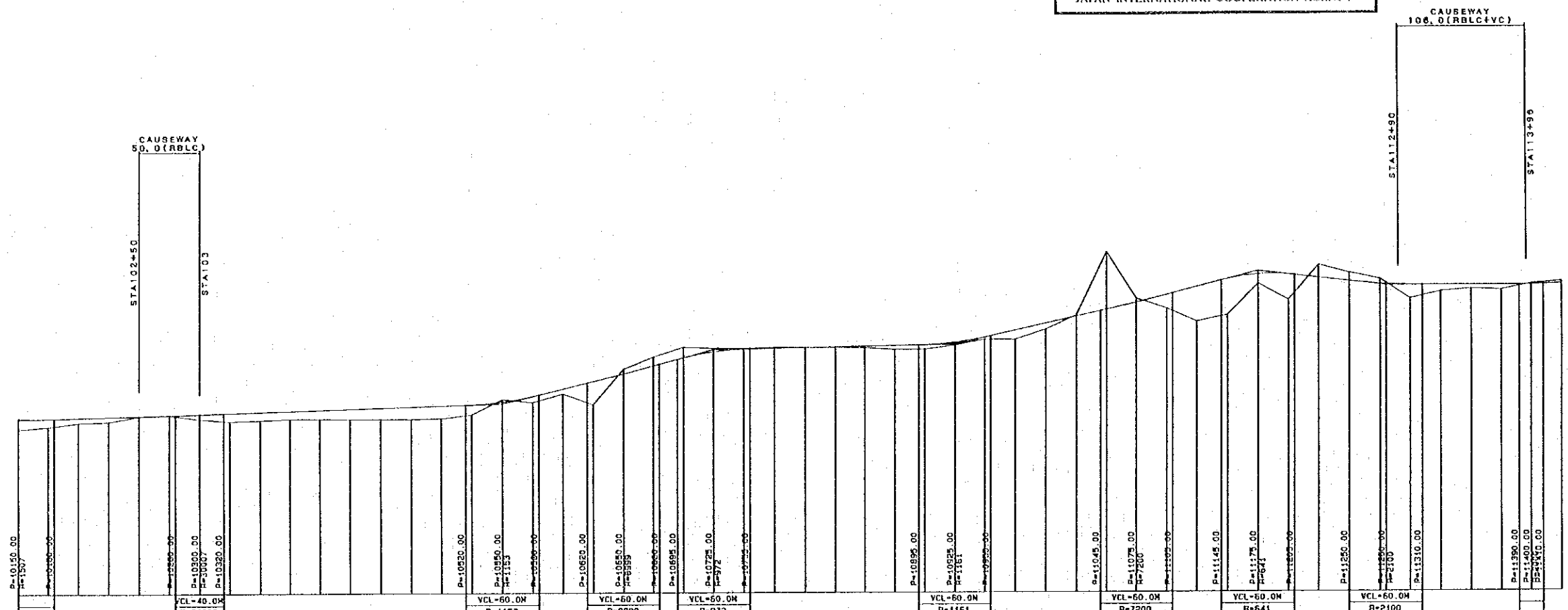
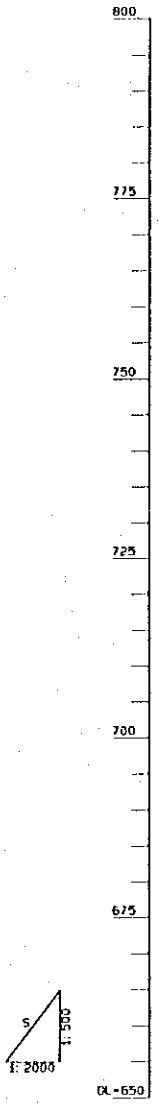

GRADE	PROPOSED HEIGHT	GROUND HEIGHT	CUTTING DEPTH	EMBANKMENT HEIGHT	ACCUMULATED DISTANCE	DISTANCE	STATION	CURVE ELEMENT
686.00	686.30	684.00	2.30	2.30	25.00	101+50	L=38.00 R=150.00	
686.00	686.10	684.50	1.86	1.86	25.00	101+75		
686.00	686.33	685.30	1.03	1.03	25.00	102		
686.00	686.50	685.50	1.00	1.00	25.00	102+25		
686.00	686.67	686.60	0.07	0.07	25.00	102+50		
686.00	686.83	686.80	0.02	0.02	25.00	102+75		
687.00	687.01	686.00	1.01	1.01	25.00	103		
687.00	687.20	685.50	1.70	1.70	25.00	103+25		
687.00	687.40	685.70	1.70	1.70	25.00	103+50		
687.00	687.60	686.00	1.60	1.60	25.00	103+75		
687.00	687.80	686.00	1.80	1.80	25.00	104		
687.00	688.20	685.90	2.10	2.10	25.00	104+25		
687.00	688.40	685.90	2.30	2.30	25.00	104+50		
687.00	688.60	685.90	2.50	2.50	25.00	104+75		
687.00	689.00	686.00	2.60	2.60	25.00	105		
687.00	689.50	686.80	2.01	2.01	25.00	105+25		
687.00	689.90	689.30	0.31	0.31	25.00	105+50		
687.00	690.30	689.30	1.21	1.21	25.00	105+75		
687.00	690.50	689.00	1.00	1.00	25.00	106		
687.00	690.70	688.80	4.70	4.70	25.00	106+25		
687.00	690.90	689.00	0.90	0.90	25.00	106+50		
687.00	691.10	689.30	1.83	1.83	25.00	106+75		
687.00	691.30	689.30	2.16	2.16	25.00	107		
687.00	691.50	689.30	0.76	0.76	25.00	107+25		
687.00	691.70	689.30	0.08	0.08	25.00	107+50		
687.00	691.90	689.30	0.25	0.25	25.00	107+75		
687.00	692.10	689.30	0.02	0.02	25.00	108		
687.00	692.30	689.30	0.10	0.10	25.00	108+25		
687.00	692.50	689.30	0.33	0.33	25.00	108+50		
687.00	692.70	689.30	0.73	0.73	25.00	108+75		
687.00	692.90	689.30	0.89	0.89	25.00	109		
687.00	693.10	689.30	0.59	0.59	25.00	109+25		
687.00	693.30	689.30	0.43	0.43	25.00	109+50		
687.00	693.50	689.30	1.83	1.83	25.00	109+75		
687.00	693.70	689.30	1.25	1.25	25.00	110		
687.00	693.90	689.30	0.23	0.23	25.00	110+25		
687.00	694.10	689.30	11.82	11.82	25.00	110+50		
687.00	694.30	689.30	0.64	0.64	25.00	110+75		
687.00	694.50	689.30	2.83	2.83	25.00	111		
687.00	694.70	689.30	7.15	7.15	25.00	111+25		
687.00	694.90	689.30	7.46	7.46	25.00	111+50		
687.00	695.10	689.30	1.90	1.90	25.00	111+75		
687.00	695.30	689.30	5.27	5.27	25.00	112		
687.00	695.50	689.30	2.83	2.83	25.00	112+25		
687.00	695.70	689.30	1.74	1.74	25.00	112+50		
687.00	695.90	689.30	1.01	1.01	25.00	112+75		
687.00	696.10	689.30	2.82	2.82	25.00	113		
687.00	696.30	689.30	1.30	1.30	25.00	113+25		
687.00	696.50	689.30	0.80	0.80	25.00	113+50		
687.00	696.70	689.30	1.00	1.00	25.00	113+75		
687.00	696.90	689.30	0.17	0.17	25.00	114		
687.00	697.10	689.30	0.35	0.35	25.00	114+25		

HIS MAJESTY'S GOVERNMENT OF NEPAL
 MINISTRY OF WORKS AND TRANSPORT
 DEPARTMENT OF ROADS
 AFTERCARE STUDY
 FOR
 SINDHULI ROAD CONSTRUCTION PROJECT
 PROFILE SECTION II-3
 SHEET NO. B-105
 SCALE: HOR. 1:2000 VER. 1:500
 DATE:
 JAPAN INTERNATIONAL COOPERATION AGENCY

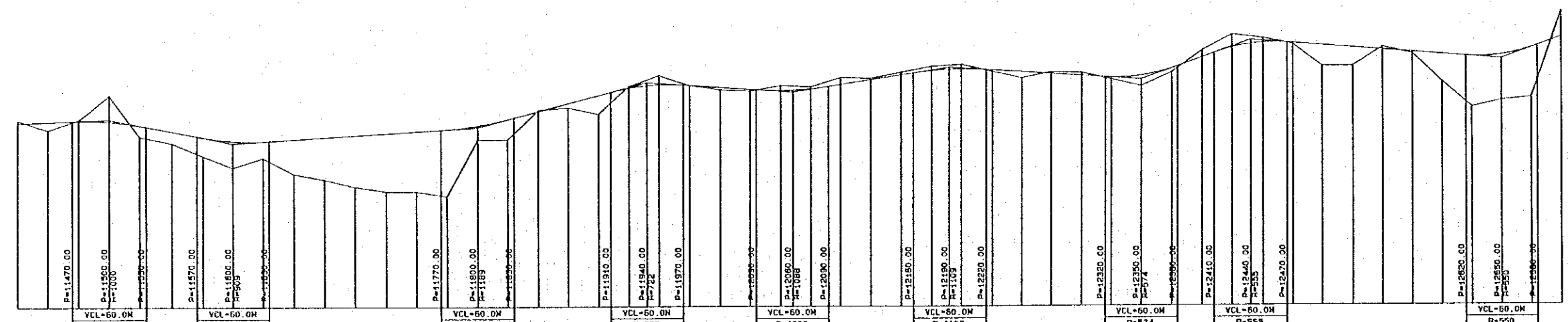
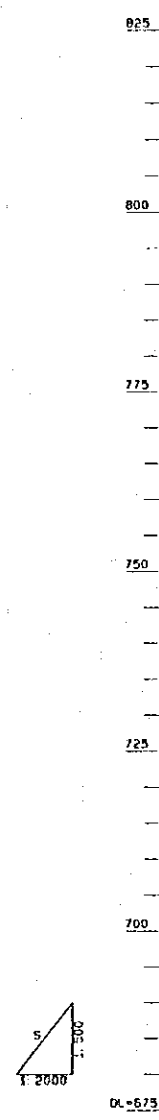

GRADE	PROPOSED HEIGHT	GROUND HEIGHT	CUTTING DEPTH	EMBANKMENT HEIGHT	ACCUMULATED DISTANCE	DISTANCE	STATION	CURVE ELEMENT
+1.0000% 100.00M	713.25	713.80	0.55	1.70		25.00	114+25	L=297.45
714.00	713.50	711.80	0.16			25.00	114+50	
-5.0000% 100.00M	713.74	713.90	5.45	2.34		25.00	114+75	
714.00	713.55	719.00	0.16			25.00	115	
712.74	712.74	710.40	2.40	3.66		25.00	115+25	
709.00	711.50	709.10	2.40	5.50		25.00	115+50	
710.25	710.25	706.40	3.41	7.13		25.00	115+75	
709.00	709.50	704.00	3.41	8.70		25.00	116	
708.41	708.41	706.00	7.13	10.50		25.00	116+25	
709.80	709.80	702.67	8.70	12.00		25.00	116+50	
710.20	710.20	701.50	10.50	12.40		25.00	116+75	
711.00	711.00	700.00	12.00	13.81		25.00	117	
711.40	711.40	699.00	12.40	14.17		25.00	117+25	
711.81	711.81	699.00	13.81	15.629%		25.00	117+50	
712.58	712.58	699.00	2.86	17.10		25.00	117+75	
713.87	713.87	709.70	4.17	18.59		25.00	118	
715.52	715.52	709.70	0.28	2.86		25.00	118+25	
717.18	717.18	715.30	0.88	4.17		25.00	118+50	
719.84	719.84	715.00	0.88	5.49		25.00	118+75	
720.34	720.34	715.00	0.88	6.81		25.00	119	
721.05	721.05	720.70	0.36	8.13		25.00	119+25	
720.92	720.92	723.00	1.95	9.45		25.00	119+50	
720.50	720.50	723.00	0.02	10.77		25.00	119+75	
720.50	720.50	720.00	0.50	12.10		25.00	120	
720.08	720.08	719.70	0.38	13.42		25.00	120+25	
719.95	719.95	720.90	1.05	14.74		25.00	120+50	
720.18	720.18	720.60	0.42	16.06		25.00	120+75	
721.04	721.04	722.50	1.45	17.38		25.00	121	
722.00	722.00	722.30	0.30	18.70		25.00	121+25	
722.96	722.96	723.50	0.54	20.02		25.00	121+50	
723.82	723.82	724.70	0.88	21.34		25.00	121+75	
724.15	724.15	725.10	0.94	22.66		25.00	122	
723.95	723.95	723.60	0.35	23.98		25.00	122+25	
723.95	723.95	722.30	1.26	25.30		25.00	122+50	
723.95	723.95	723.30	0.33	26.62		25.00	122+75	
722.78	722.78	723.50	0.62	27.94		25.00	123	
722.41	722.41	723.40	0.41	29.26		25.00	123+25	
722.78	722.78	720.60	2.18	30.58		25.00	123+50	
724.24	724.24	723.40	0.84	31.90		25.00	123+75	
726.44	726.44	727.90	1.46	33.22		25.00	124	
728.47	728.47	731.10	2.53	34.54		25.00	124+25	
729.45	729.45	730.40	0.95	35.86		25.00	124+50	
729.33	729.33	729.10	0.23	37.18		25.00	124+75	
728.06	728.06	724.60	4.26	38.50		25.00	125	
728.38	728.38	724.60	3.78	39.82		25.00	125+25	
727.90	727.90	728.50	0.60	41.14		25.00	125+50	
727.43	727.43	727.10	0.33	42.46		25.00	125+75	
726.95	726.95	721.30	5.65	43.78		25.00	126	
726.50	726.50	716.00	10.50	45.10		25.00	126+25	
726.82	726.82	717.40	9.42	46.42		25.00	126+50	
728.27	728.27	718.00	10.27	47.74		25.00	126+75	
730.50	730.50	726.91	5.41	49.06		25.00	127	

HIS MAJESTY'S GOVERNMENT OF NEPAL
 MINISTRY OF WORKS AND TRANSPORT
 DEPARTMENT OF ROADS
 AFTERCARE STUDY
 FOR
 SINDHULI ROAD CONSTRUCTION PROJECT
 PROFILE SECTION II-3
 SHEET NO. B-108
 SCALE: HOR. 1:2000 VER. 1:500
 DATE
 JAPAN INTERNATIONAL COOPERATION AGENCY

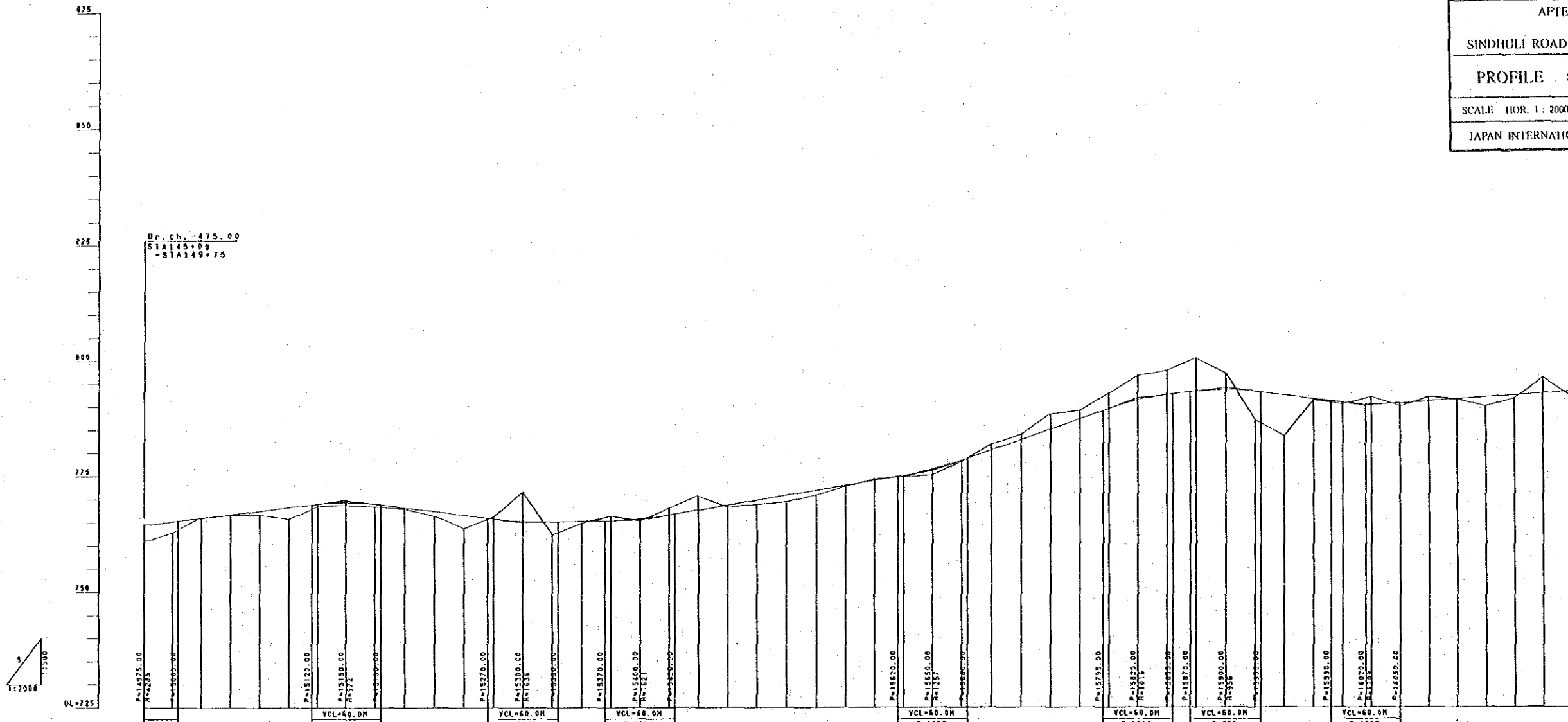

GRADE	PROPOSED HEIGHT	GROUND HEIGHT	CUTTING DEPTH	EMBANKMENT HEIGHT	ACCUMULATED DISTANCE	DISTANCE	STATION	CURVE ELEMENT
764.50	764.61	761.00		3.61		25.00	149+75	L=133.51
+3.0000% 175.00M	765.25	762.50		2.75		25.00	150	
	766.00	766.20	0.20			25.00	150+25	
	766.75	766.60		0.15		25.00	150+50	L=92.79 R=180.00
	767.50	766.70		0.80		25.00	150+75	
	768.25	765.80		2.45		25.00	151	
	768.99	768.50		0.49		25.00	151+25	L=38.92
	769.75	768.70		0.55		25.00	151+50	
	768.95	768.40		0.55		25.00	151+75	
	768.17	767.90		0.27		25.00	152	
	767.37	766.40		0.97		25.00	152+25	
	766.58	763.80		2.78		25.00	152+50	
	765.00	766.20	0.40			25.00	152+75	
	765.28	771.50	6.22			25.00	153	
	765.14	762.40		2.74		25.00	153+25	
	765.25	764.80		0.45		25.00	153+50	
	765.39	766.40	1.01			25.00	153+75	
	765.75	765.30		0.48		25.00	154	
	766.56	768.00	1.44			25.00	154+25	
	767.60	770.60	3.00			25.00	154+50	
	768.65	784.20	11.55			25.00	154+75	
	769.70	768.80		0.90		25.00	155	
	770.75	769.30		1.42		25.00	155+25	
	771.80	770.80		1.00		25.00	155+50	
	772.85	772.60		0.25		25.00	155+75	
	773.90	774.20	0.30			25.00	156	
	774.96	774.70		0.26		25.00	156+25	
	776.00	775.10		0.90		25.00	156+50	
	778.25	778.00		0.25		25.00	156+75	
	786.49	781.70		4.79		25.00	157	
	782.73	783.90	1.17			25.00	157+25	
	784.97	784.30		0.67		25.00	157+50	
	787.21	783.00		4.21		25.00	157+75	
	789.45	782.80		6.65		25.00	158	
	791.26	796.50	5.24			25.00	158+25	
	792.46	797.70	5.24			25.00	158+50	
	793.22	800.30	7.08			25.00	158+75	
	794.00	797.10	3.57			25.00	159	
	793.19	787.00		6.19		25.00	159+25	
	792.40	783.50		8.90		25.00	159+50	
	791.59	791.30		0.29		25.00	159+75	
	790.83	790.40		0.43		25.00	160	
	790.50	792.00	1.50			25.00	160+25	
	790.68	790.00		0.68		25.00	160+50	
	791.11	792.00	0.89			25.00	160+75	
	791.55	791.50		0.05		25.00	161	
	791.99	790.00		1.99		25.00	161+25	
	792.43	791.70		0.73		25.00	161+50	
	792.87	794.20	3.32			25.00	161+75	
	793.30	792.20		1.10		25.00	162	

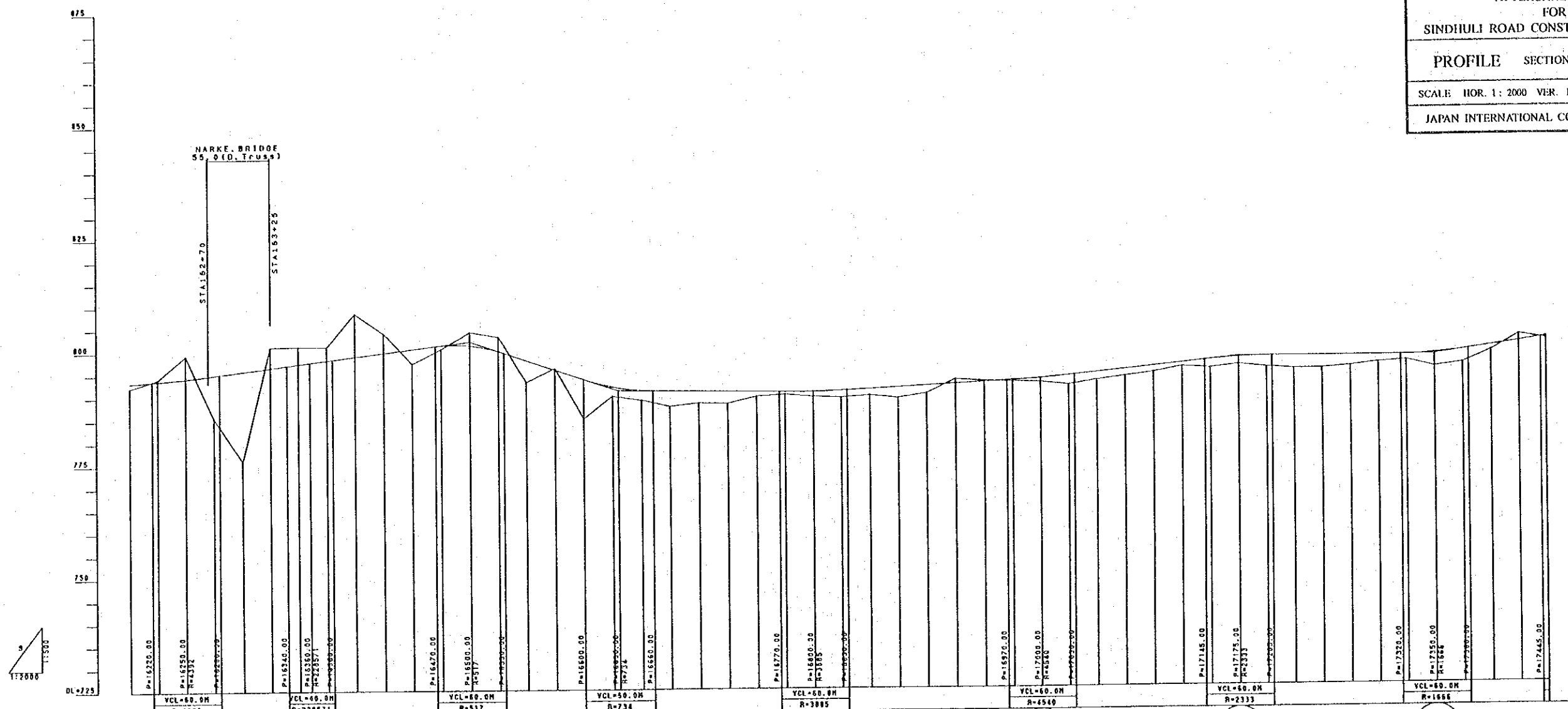

GRADE	PROPOSED HEIGHT	GROUND HEIGHT	CUTTING DEPTH	EMBANKMENT HEIGHT	ACCUMULATED DISTANCE	DISTANCE	STATION	CURVE ELEMENT
1.10	793.30	792.20	0.36	1.10		25.00	162	L=109.11
1.10	793.74	794.10	0.36	1.10		25.00	162+25	
1.10	794.28	795.20	0.36	1.10		25.00	162+50	
1.10	794.86	795.40	0.36	1.10		25.00	162+75	
1.10	795.74	776.30	0.36	1.10		25.00	163	
1.10	796.32	801.00	0.36	1.10		25.00	163+25	
1.10	797.30	801.10	0.36	1.10		25.00	163+50	
1.10	798.08	801.00	0.36	1.10		25.00	163+75	
1.10	798.86	808.30	0.36	1.10		25.00	164	
1.10	799.65	803.30	0.36	1.10		25.00	164+25	
1.10	800.43	797.20	0.36	1.10		25.00	164+50	
1.10	801.20	800.40	0.36	1.10		25.00	164+75	
1.10	801.13	804.10	0.36	1.10		25.00	165	
1.10	799.86	803.00	0.36	1.10		25.00	165+25	
1.10	797.77	793.00	0.36	1.10		25.00	165+50	
1.10	795.65	796.00	0.36	1.10		25.00	165+75	
1.10	793.54	784.30	0.36	1.10		25.00	166	
1.10	791.05	789.80	0.36	1.10		25.00	166+25	
1.10	791.01	788.30	0.36	1.10		25.00	166+50	
1.10	790.87	787.50	0.36	1.10		25.00	166+75	
1.10	790.79	788.20	0.36	1.10		25.00	167	
1.10	790.72	788.10	0.36	1.10		25.00	167+25	
1.10	790.65	789.60	0.36	1.10		25.00	167+50	
1.10	790.57	790.00	0.36	1.10		25.00	167+75	
1.10	790.50	789.50	0.36	1.10		25.00	168	
1.10	790.81	789.30	0.36	1.10		25.00	168+25	
1.10	791.13	789.70	0.36	1.10		25.00	168+50	
1.10	791.44	789.10	0.36	1.10		25.00	168+75	
1.10	791.75	790.00	0.36	1.10		25.00	169	
1.10	792.06	793.00	0.36	1.10		25.00	169+25	
1.10	792.38	792.60	0.36	1.10		25.00	169+50	
1.10	792.69	792.40	0.36	1.10		25.00	169+75	
1.10	793.00	792.20	0.36	1.10		25.00	170	
1.10	793.34	791.60	0.36	1.10		25.00	170+25	
1.10	794.29	792.60	0.36	1.10		25.00	170+50	
1.10	794.89	793.40	0.36	1.10		25.00	170+75	
1.10	795.37	794.20	0.36	1.10		25.00	171	
1.10	795.81	795.40	0.36	1.10		25.00	171+25	
1.10	796.85	795.00	0.36	1.10		25.00	171+50	
1.10	797.31	795.70	0.36	1.10		25.00	171+75	
1.10	797.49	795.10	0.36	1.10		25.00	172	
1.10	797.50	794.70	0.36	1.10		25.00	172+25	
1.10	797.50	794.70	0.36	1.10		25.00	172+50	
1.10	797.50	795.20	0.36	1.10		25.00	172+75	
1.10	797.50	795.30	0.36	1.10		25.00	173	
1.10	797.50	796.30	0.36	1.10		25.00	173+25	
1.10	797.50	794.60	0.36	1.10		25.00	173+50	
1.10	797.50	795.60	0.36	1.10		25.00	173+75	
1.10	797.50	796.20	0.36	1.10		25.00	174	
1.10	797.50	798.20	0.36	1.10		25.00	174+25	
1.10	797.50	801.70	0.36	1.10		25.00	174+50	
1.10	801.00	800.70	0.36	1.10		25.00	174+50	

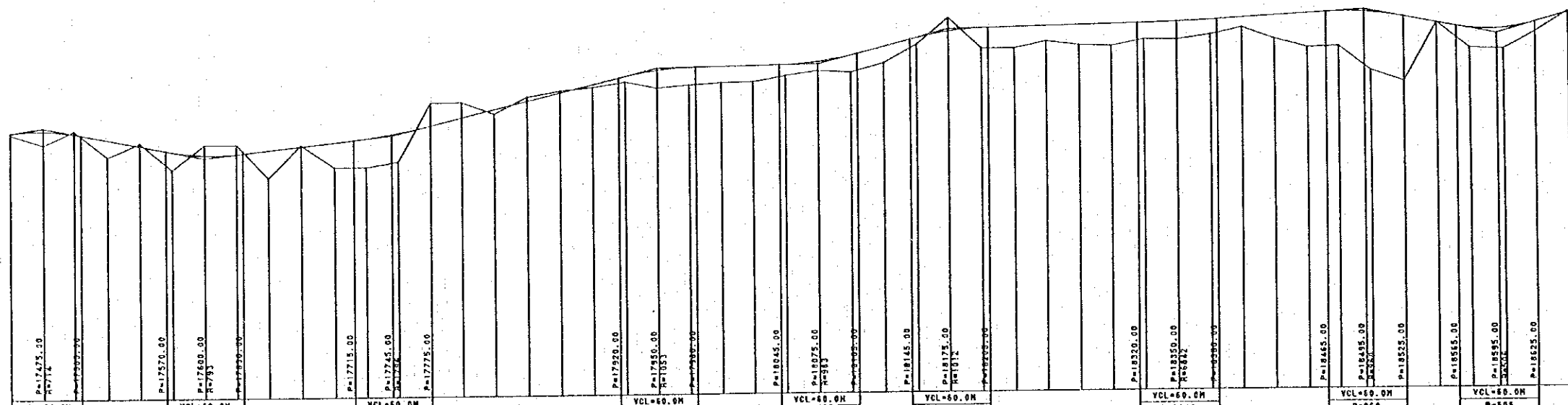

GRADE	PROPOSED HEIGHT	GROUND HEIGHT	CUTTING DEPTH	EMBANKMENT HEIGHT	ACCUMULATED DISTANCE	DISTANCE	STATION	CURVE ELEMENT
801.08	801.08	800.70	0.38	0.38		25.00	174+50	L=98.35
801.37	801.37	798.74	2.63	2.63		25.00	174+75	L=46.51, R=100.00
800.76	800.76	801.30	0.52	3.23		25.00	175	L=125+10.25
799.60	799.60	796.31	3.29	3.42		25.00	175+25	L=125+51.25
798.40	798.40	798.91	0.51	3.42		25.00	175+50	L=101.01, R=700.00
797.22	797.22	793.80	3.42	5.29		25.00	175+75	L=174+52.25
796.57	796.57	798.50	1.93	5.29		25.00	176	L=174+52.25
796.71	796.71	798.50	1.79	4.76		25.00	176+25	L=174+52.25
797.33	797.33	792.10	5.23	4.76		25.00	176+50	L=174+52.25
798.07	798.07	798.30	0.23	5.48		25.00	176+75	L=174+52.25
798.76	798.76	794.00	4.76	5.47		25.00	177	L=938.31
799.48	799.48	794.00	5.48	5.47		25.00	177+25	
800.47	800.47	795.00	5.47	5.47		25.00	177+50	
801.83	801.83	806.20	4.37	5.47		25.00	177+75	
803.35	803.35	806.30	2.95	5.47		25.00	178	
804.88	804.88	804.00	0.88	5.47		25.00	178+25	
806.40	806.40	807.20	0.80	5.47		25.00	178+50	
807.93	807.93	808.30	0.37	5.47		25.00	178+75	
809.45	809.45	808.50	0.95	5.47		25.00	179	
810.97	810.97	809.90	1.07	5.47		25.00	179+25	
812.50	812.50	808.70	3.80	5.47		25.00	179+50	
812.50	812.50	809.20	3.30	5.47		25.00	179+75	
812.50	812.50	805.60	6.90	5.47		25.00	180	
812.50	812.50	809.70	2.80	5.47		25.00	180+25	
812.91	812.91	810.80	2.11	5.47		25.00	180+50	
813.46	813.46	811.70	1.76	5.47		25.00	180+75	
814.86	814.86	811.40	3.46	5.47		25.00	181	
816.25	816.25	813.10	3.15	5.47		25.00	181+25	
817.87	817.87	816.60	1.27	5.47		25.00	181+50	
819.06	819.06	821.60	2.54	5.47		25.00	181+75	
819.63	819.63	815.70	3.93	5.47		25.00	182	
819.79	819.79	815.70	4.09	5.47		25.00	182+25	
819.93	819.93	817.00	2.93	5.47		25.00	182+50	
820.07	820.07	816.20	3.87	5.47		25.00	182+75	
820.21	820.21	816.50	3.71	5.47		25.00	183	
820.36	820.36	817.20	3.16	5.47		25.00	183+25	
820.50	820.50	817.10	3.40	5.47		25.00	183+50	
820.96	820.96	818.02	2.94	5.47		25.00	183+75	
821.22	821.22	819.33	1.89	5.47		25.00	184	
821.59	821.59	817.07	4.52	5.47		25.00	184+25	
821.95	821.95	815.40	6.55	5.47		25.00	184+50	
822.26	822.26	815.57	6.69	5.47		25.00	184+75	
822.03	822.03	810.88	11.15	5.47		25.00	185	
821.16	821.16	808.77	12.39	5.47		25.00	185+25	
819.96	819.96	820.00	0.04	5.47		25.00	185+50	
818.86	818.86	815.00	3.86	5.47		25.00	185+75	
816.77	816.77	814.00	2.77	5.47		25.00	186	
819.91	819.91	818.00	1.91	5.47		25.00	186+25	
821.68	821.68	821.90	0.22	5.47		25.00	186+50	

HIS MAJESTY'S GOVERNMENT OF NEPAL
 MINISTRY OF WORKS AND TRANSPORT
 DEPARTMENT OF ROADS

AFTERCARE STUDY
 FOR
 SINDHULI ROAD CONSTRUCTION PROJECT

PROFILE SECTION II-3	SHEET NO. B - 111
SCALE HOR. 1:2000 VER. 1:500	DATE

JAPAN INTERNATIONAL COOPERATION AGENCY

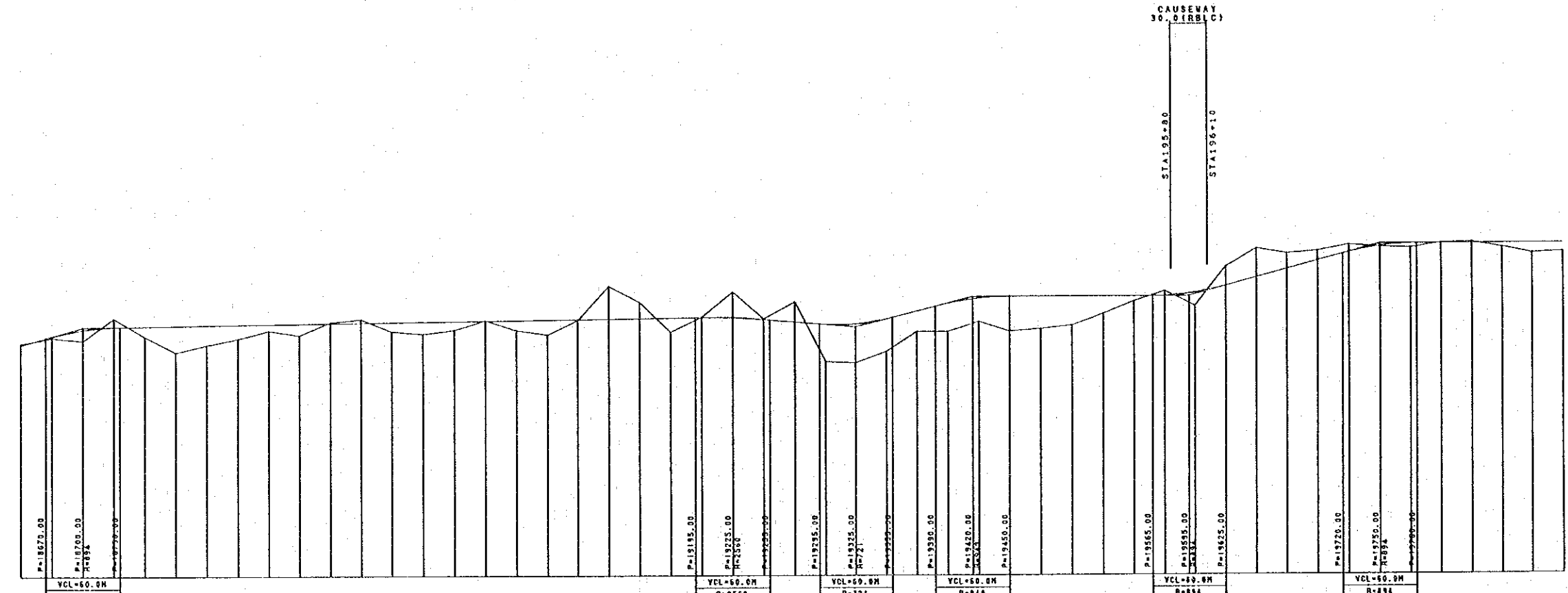
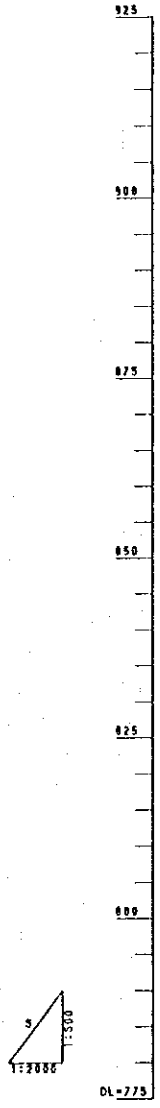

GRADE	PROPOSED HEIGHT	GROUND HEIGHT	CUTTING DEPTH	EMBANKMENT HEIGHT	ACCUMULATED DISTANCE	DISTANCE	STATION	CURVE ELEMENT
157.04753 195.00M	821.68	821.90	0.22	0.33		25.00	186+50	L=189.66
825.20	823.43	823.10	0.33	0.33		25.00	186+75	L=189.66 R=308.88
825.20	824.70	822.50	2.20	2.20		25.00	187	
10.34295 525.00M	825.28	827.00	1.72	0.72		25.00	187+25	L=30.28
825.37	823.30	823.30	0.07	2.07		25.00	187+50	L=30.28 R=308.88
825.48	820.10	820.10	5.38	5.38		25.00	187+75	
825.54	821.50	821.50	4.04	4.04		25.00	188	
825.63	822.80	822.80	2.83	2.83		25.00	188+25	
825.71	824.40	824.40	1.31	1.31		25.00	188+50	
825.80	823.40	823.40	2.40	2.40		25.00	188+75	
825.89	826.10	826.10	0.21	0.21		25.00	189	
825.97	826.70	826.70	0.73	0.73		25.00	189+25	
826.06	824.20	824.20	1.86	1.86		25.00	189+50	
826.14	823.70	823.70	2.44	2.44		25.00	189+75	
826.23	824.50	824.50	1.73	1.73		25.00	190	
826.31	826.40	826.40	0.09	0.09		25.00	190+25	
826.40	824.40	824.40	2.00	2.00		25.00	190+50	
826.45	823.50	823.50	2.95	2.95		25.00	190+75	
826.57	826.40	826.40	0.17	0.17		25.00	191	
826.66	833.20	833.20	6.54	6.54		25.00	191+25	
826.74	830.00	830.00	3.26	3.26		25.00	191+50	
826.83	824.00	824.00	2.83	2.83		25.00	191+75	
826.91	827.00	827.00	0.09	0.09		25.00	192	
827.02	832.00	832.00	5.18	5.18		25.00	192+25	
827.10	826.67	826.67	0.43	0.43		25.00	192+50	
827.18	830.00	830.00	4.82	4.82		25.00	192+75	
827.26	818.00	818.00	9.26	9.26		25.00	193	
827.34	817.00	817.00	10.26	10.26		25.00	193+25	
827.42	820.00	820.00	8.26	8.26		25.00	193+50	
827.50	824.00	824.00	4.16	4.16		25.00	193+75	
827.58	826.00	826.00	5.89	5.89		25.00	194	
827.66	826.00	826.00	4.67	4.67		25.00	194+25	
827.74	824.00	824.00	7.00	7.00		25.00	194+50	
827.82	824.50	824.50	6.50	6.50		25.00	194+75	
827.90	825.20	825.20	5.80	5.80		25.00	195	
827.98	827.50	827.50	3.50	3.50		25.00	195+25	
828.06	830.00	830.00	1.00	1.00		25.00	195+50	
828.14	832.00	832.00	0.54	0.54		25.00	195+75	
828.22	825.00	825.00	2.89	2.89		25.00	196	
828.30	836.90	836.90	3.89	3.89		25.00	196+25	
828.38	840.50	840.50	5.81	5.81		25.00	196+50	
828.46	839.50	839.50	3.13	3.13		25.00	196+75	
828.54	840.00	840.00	1.95	1.95		25.00	197	
828.62	841.20	841.20	1.49	1.49		25.00	197+25	
828.70	840.90	840.90	0.20	0.20		25.00	197+50	
828.78	840.50	840.50	0.49	0.49		25.00	197+75	
828.86	841.50	841.50	0.10	0.10		25.00	198	
828.94	841.60	841.60	0.20	0.20		25.00	198+25	
829.02	840.60	840.60	0.80	0.80		25.00	198+50	
829.10	839.40	839.40	2.00	2.00		25.00	198+75	
829.18	839.70	839.70	1.70	1.70		25.00	199	

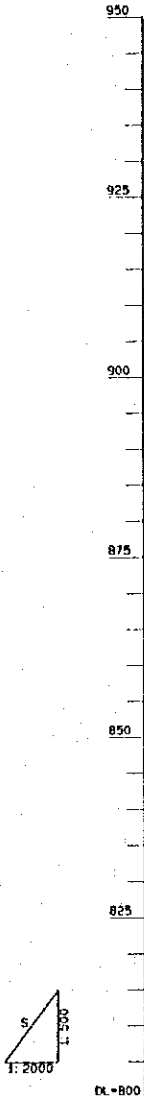

B.F. ch. +100.00
 STA 204
 = STA 203

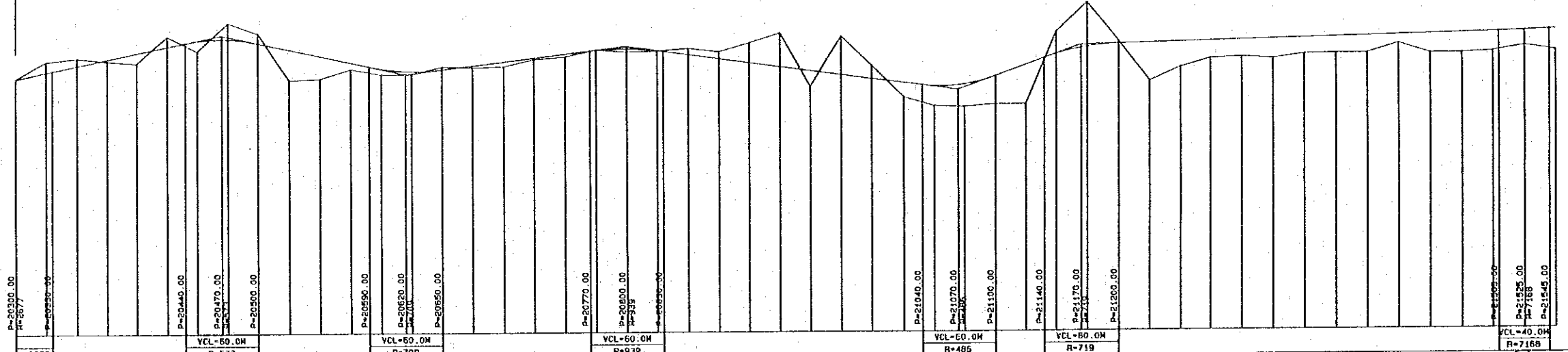

GRADE	PROPOSED HEIGHT	GROUND HEIGHT	CUTTING DEPTH	EMBANKMENT HEIGHT	ACCUMULATED DISTANCE	DISTANCE	STATION	CURVE ELEMENT
852.00	851.83	852.00	0.17			25.00	203	L-239.68
	853.26	855.40	2.14			25.00	203+25	L-42.25
	854.53	856.10	1.57			25.00	203+50	R-100.00
	855.79	855.40	0.39	0.39		25.00	203+75	L-43.80
	857.05	855.00	2.06	2.06		25.00	204	R-100.00
	859.32	860.40	2.08	2.10		25.00	204+25	L-43.80
	859.50	857.40	3.31	2.10		25.00	204+50	R-100.00
	859.79	863.10	2.02	6.23		25.00	204+75	L-43.80
	859.98	861.00	0.58	4.58		25.00	205	L-43.80
	859.53	851.40	0.07	6.23		25.00	205+25	L-43.80
	857.23	851.70	0.07	4.58		25.00	205+50	L-43.80
	857.52	854.93	0.02	0.39		25.00	206	L-43.80
	857.15	854.00	0.06	0.94		25.00	206+25	L-43.80
	856.33	854.94	1.27	0.31		25.00	206+50	L-43.80
	855.50	855.40	1.40	0.57		25.00	206+75	L-43.80
	854.67	855.90	4.03	0.57		25.00	207	L-43.80
	853.83	856.70	5.87	0.57		25.00	207+25	L-43.80
	853.00	849.70	7.83	0.57		25.00	207+50	L-43.80
	852.17	850.00	2.67	0.57		25.00	207+75	L-43.80
	851.33	854.00	2.67	0.57		25.00	208	L-43.80
	850.50	847.50	3.00	0.57		25.00	208+25	L-43.80
	849.67	845.70	4.07	0.57		25.00	208+50	L-43.80
	848.83	845.50	4.59	0.57		25.00	208+75	L-43.80
	848.00	846.00	5.70	0.57		25.00	209	L-43.80
	847.17	846.00	7.99	0.57		25.00	209+25	L-43.80
	846.33	846.00	4.47	0.57		25.00	209+50	L-43.80
	845.50	850.60	9.00	0.57		25.00	209+75	L-43.80
	844.67	856.60	0.50	0.57		25.00	210	L-43.80
	843.83	856.70	7.78	0.57		25.00	210+25	L-43.80
	843.00	856.36	5.13	0.57		25.00	210+50	L-43.80
	842.17	853.40	3.60	0.57		25.00	211	L-43.80
	841.33	855.10	3.46	0.57		25.00	211+25	L-43.80
	840.50	852.40	4.03	0.57		25.00	211+50	L-43.80
	839.67	855.90	3.29	0.57		25.00	212	L-43.80
	838.83	856.00	3.36	0.57		25.00	212+25	L-43.80
	838.00	859.03	1.79	0.57		25.00	212+50	L-43.80
	837.17	859.19	3.02	0.57		25.00	213	L-43.80
	836.33	859.36	3.03	0.57		25.00	213+25	L-43.80
	835.50	860.02	4.12	0.57		25.00	213+50	L-43.80
	834.67	856.20	3.96	0.57		25.00	214	L-43.80
	833.83	857.30	3.08	0.57		25.00	214+25	L-43.80
	833.00	856.40	4.26	0.57		25.00	214+50	L-43.80

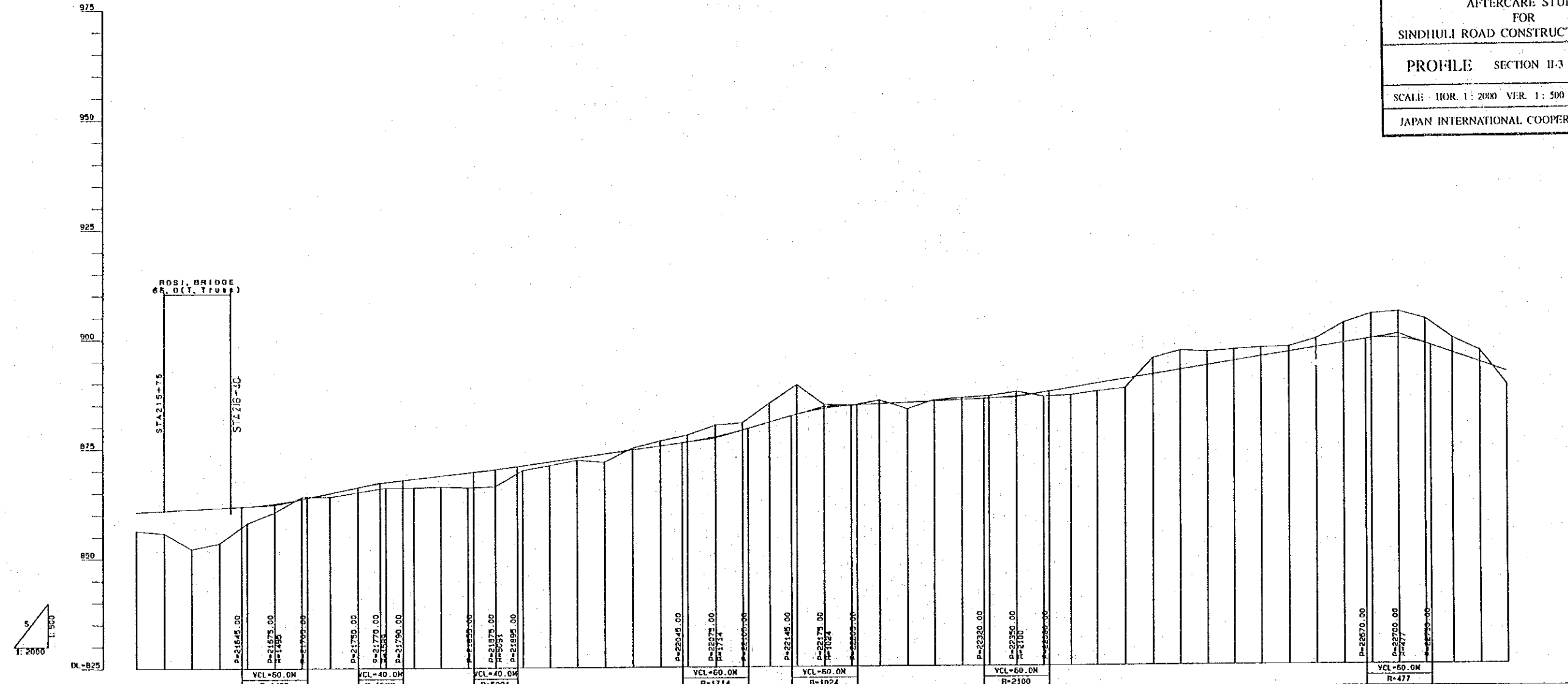

GRADE	PROPOSED HEIGHT	GROUND HEIGHT	CUTTING DEPTH	EMBANKMENT HEIGHT	ACCUMULATED DISTANCE	DISTANCE	STATION	CURVE ELEMENT
+1.2200% 150.00M	856.56	856.40	0.16	4.25		25.00	215+50	L=34.07 R=1495
862.18	855.90	855.20	0.70	5.15		25.00	215+75	L=34.07 R=1495
+5.2316% 95.00M	861.27	852.20	0.97	9.07		25.00	216	L=34.07 R=1495
867.15	853.50	853.50	0.00	8.07		25.00	216+25	L=34.07 R=1495
872.22	858.00	858.00	0.00	3.89		25.00	216+50	L=34.07 R=1495
877.22	860.50	860.50	0.00	1.96		25.00	216+75	L=34.07 R=1495
882.18	864.00	864.00	0.00	0.90		25.00	217	L=34.07 R=1495
887.15	865.10	865.10	0.00	1.10		25.00	217+25	L=34.07 R=1495
892.18	866.00	866.00	0.00	1.22		25.00	217+50	L=34.07 R=1495
897.15	866.00	866.00	0.00	1.96		25.00	217+75	L=34.07 R=1495
902.18	866.00	866.00	0.00	1.96		25.00	218	L=34.07 R=1495
907.15	866.20	866.20	0.00	2.44		25.00	218+25	L=34.07 R=1495
912.18	868.64	868.64	0.00	3.32		25.00	218+50	L=34.07 R=1495
917.15	869.32	869.32	0.00	3.84		25.00	218+75	L=34.07 R=1495
922.18	870.04	870.04	0.00	1.08		25.00	219	L=34.07 R=1495
927.15	870.88	870.88	0.00	0.85		25.00	219+25	L=34.07 R=1495
932.18	871.75	871.75	0.00	0.93		25.00	219+50	L=34.07 R=1495
937.15	872.63	872.63	0.00	1.90		25.00	219+75	L=34.07 R=1495
942.18	873.50	873.50	0.00	0.42		25.00	220	L=34.07 R=1495
947.15	874.38	874.38	0.00	1.15		25.00	220+25	L=34.07 R=1495
952.18	875.25	875.25	0.00	1.55		25.00	220+50	L=34.07 R=1495
957.15	876.14	876.14	0.00	2.64		25.00	220+75	L=34.07 R=1495
962.18	877.02	877.02	0.00	1.64		25.00	221	L=34.07 R=1495
967.15	877.90	877.90	0.00	4.30		25.00	221+25	L=34.07 R=1495
972.18	878.78	878.78	0.00	5.75		25.00	221+50	L=34.07 R=1495
977.15	879.65	879.65	0.00	0.94		25.00	221+75	L=34.07 R=1495
982.18	880.50	880.50	0.00	0.06		25.00	222	L=34.07 R=1495
987.15	881.35	881.35	0.00	1.46		25.00	222+25	L=34.07 R=1495
992.18	882.24	882.24	0.00	0.93		25.00	222+50	L=34.07 R=1495
997.15	883.10	883.10	0.00	1.46		25.00	222+75	L=34.07 R=1495
1002.18	883.96	883.96	0.00	0.25		25.00	223	L=34.07 R=1495
1007.15	884.80	884.80	0.00	0.47		25.00	223+25	L=34.07 R=1495
1012.18	885.63	885.63	0.00	0.58		25.00	223+50	L=34.07 R=1495
1017.15	886.43	886.43	0.00	0.99		25.00	223+75	L=34.07 R=1495
1022.18	887.21	887.21	0.00	0.91		25.00	224	L=34.07 R=1495
1027.15	888.00	888.00	0.00	1.60		25.00	224+25	L=34.07 R=1495
1032.18	888.77	888.77	0.00	1.90		25.00	224+50	L=34.07 R=1495
1037.15	889.52	889.52	0.00	2.10		25.00	224+75	L=34.07 R=1495
1042.18	890.24	890.24	0.00	3.70		25.00	225	L=34.07 R=1495
1047.15	891.00	891.00	0.00	4.40		25.00	225+25	L=34.07 R=1495
1052.18	891.71	891.71	0.00	3.10		25.00	225+50	L=34.07 R=1495
1057.15	892.40	892.40	0.00	2.90		25.00	225+75	L=34.07 R=1495
1062.18	893.08	893.08	0.00	2.00		25.00	226	L=34.07 R=1495
1067.15	893.71	893.71	0.00	1.20		25.00	226+25	L=34.07 R=1495
1072.18	894.30	894.30	0.00	2.00		25.00	226+50	L=34.07 R=1495
1077.15	894.86	894.86	0.00	4.30		25.00	226+75	L=34.07 R=1495
1082.18	895.37	895.37	0.00	5.63		25.00	227	L=34.07 R=1495
1087.15	895.83	895.83	0.00	5.04		25.00	227+25	L=34.07 R=1495
1092.18	896.24	896.24	0.00	5.67		25.00	227+50	L=34.07 R=1495
1097.15	896.60	896.60	0.00	3.35		25.00	227+75	L=34.07 R=1495
1102.18	896.91	896.91	0.00	2.53		25.00	228	L=34.07 R=1495
1107.15	897.18	897.18	0.00	2.93		25.00	228+25	L=34.07 R=1495

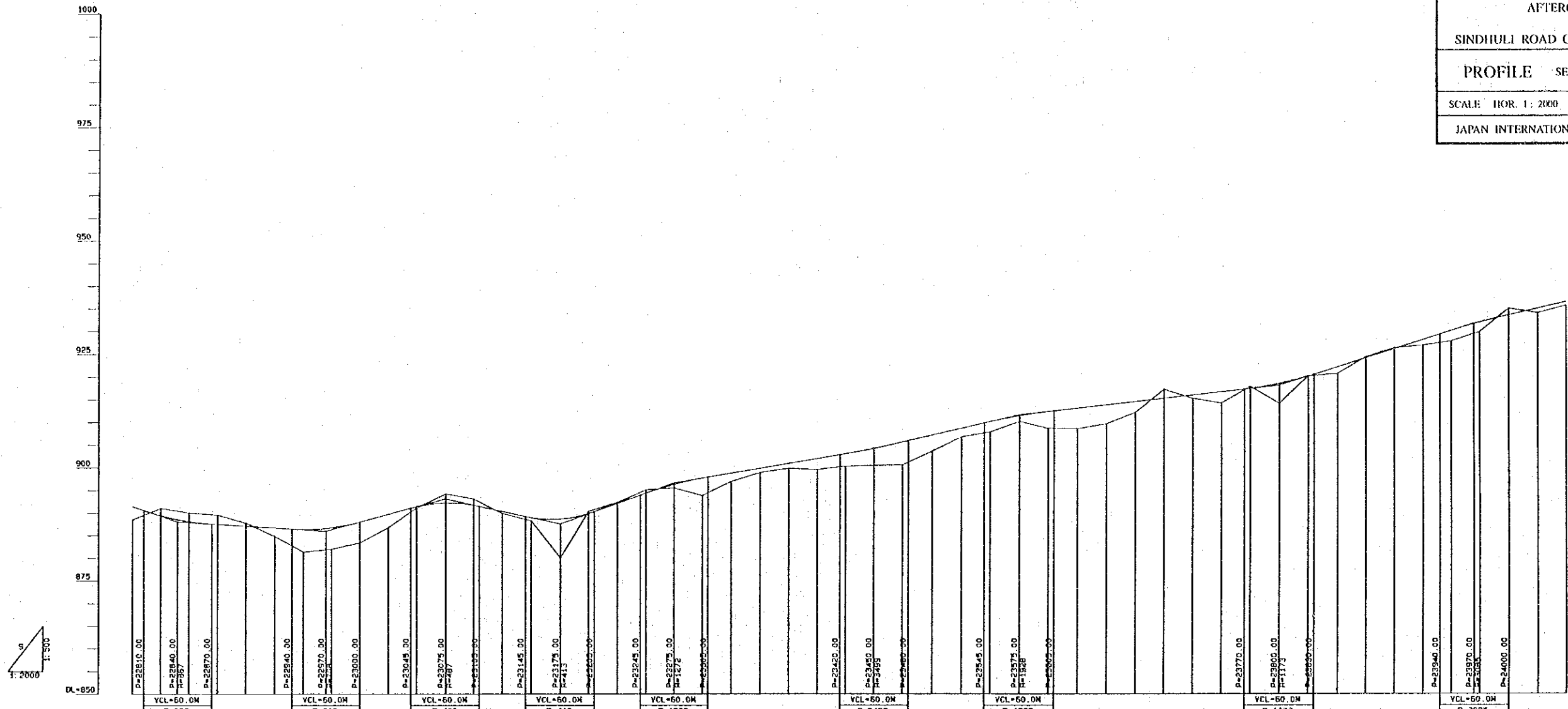

GRADE	PROPOSED HEIGHT	GROUND HEIGHT	CUTTING DEPTH	EMBANKMENT HEIGHT	ACCUMULATED DISTANCE	DISTANCE	STATION	CURVE ELEMENT
-0.5714% 140.00M	888.00	888.50	0.50	0.00	0.00	25.00	218	L=98.91
-1.6538% 130.00M	889.42	891.00	1.58	0.00	0.00	25.00	218+25	L=42.25 R=100.00
0.85% 105.00M	889.06	890.00	1.94	0.00	0.00	25.00	219+50	L=37.59 R=100.00
+5.8095% 105.00M	887.42	889.50	2.08	0.00	0.00	25.00	219+75	L=45.24 R=100.00
0.85% 105.00M	887.01	887.70	0.69	0.00	0.00	25.00	220	L=48.34
0.85% 105.00M	886.59	884.70	1.89	0.00	0.00	25.00	220+25	L=37.59 R=100.00
0.85% 105.00M	886.25	881.30	4.95	0.00	0.00	25.00	220+50	L=45.24 R=100.00
0.85% 105.00M	886.63	881.90	4.73	0.00	0.00	25.00	220+75	L=48.34
0.85% 105.00M	887.89	883.30	4.59	0.00	0.00	25.00	221	L=37.59 R=100.00
0.85% 105.00M	889.60	886.60	3.00	0.00	0.00	25.00	221+25	L=45.24 R=100.00
0.85% 105.00M	891.27	891.00	0.27	0.00	0.00	25.00	221+50	L=48.34
0.85% 105.00M	892.08	894.10	2.02	0.00	0.00	25.00	221+75	L=37.59 R=100.00
0.85% 105.00M	891.60	893.00	1.40	0.00	0.00	25.00	222	L=45.24 R=100.00
0.85% 105.00M	890.25	889.80	0.45	0.00	0.00	25.00	222+25	L=48.34
0.85% 105.00M	889.91	888.20	1.71	0.00	0.00	25.00	223	L=37.59 R=100.00
0.85% 105.00M	888.59	880.00	8.59	0.00	0.00	25.00	223+25	L=45.24 R=100.00
0.85% 105.00M	889.70	890.30	0.60	0.00	0.00	25.00	223+50	L=48.34
0.85% 105.00M	892.00	892.20	0.20	0.00	0.00	25.00	224	L=37.59 R=100.00
0.85% 105.00M	894.24	895.00	0.76	0.00	0.00	25.00	224+25	L=45.24 R=100.00
0.85% 105.00M	896.15	895.40	0.75	0.00	0.00	25.00	224+50	L=48.34
0.85% 105.00M	897.58	893.70	3.88	0.00	0.00	25.00	225	L=37.59 R=100.00
0.85% 105.00M	898.64	896.60	2.04	0.00	0.00	25.00	225+25	L=45.24 R=100.00
0.85% 105.00M	899.71	898.80	0.91	0.00	0.00	25.00	225+50	L=48.34
0.85% 105.00M	900.79	899.70	1.09	0.00	0.00	25.00	226	L=37.59 R=100.00
0.85% 105.00M	901.68	896.50	5.18	0.00	0.00	25.00	226+25	L=45.24 R=100.00
0.85% 105.00M	902.53	900.20	2.33	0.00	0.00	25.00	226+50	L=48.34
0.85% 105.00M	904.13	900.40	3.73	0.00	0.00	25.00	227	L=37.59 R=100.00
0.85% 105.00M	905.50	900.90	4.60	0.00	0.00	25.00	227+25	L=45.24 R=100.00
0.85% 105.00M	907.00	903.50	3.50	0.00	0.00	25.00	227+50	L=48.34
0.85% 105.00M	908.50	906.60	1.90	0.00	0.00	25.00	228	L=37.59 R=100.00
0.85% 105.00M	909.99	907.70	2.29	0.00	0.00	25.00	228+25	L=45.24 R=100.00
0.85% 105.00M	911.27	910.00	1.27	0.00	0.00	25.00	228+50	L=48.34
0.85% 105.00M	912.21	908.50	3.71	0.00	0.00	25.00	229	L=37.59 R=100.00
0.85% 105.00M	912.94	908.40	4.54	0.00	0.00	25.00	229+25	L=45.24 R=100.00
0.85% 105.00M	913.57	909.50	4.07	0.00	0.00	25.00	229+50	L=48.34
0.85% 105.00M	914.39	912.00	2.39	0.00	0.00	25.00	230	L=37.59 R=100.00
0.85% 105.00M	915.11	913.10	2.01	0.00	0.00	25.00	230+25	L=45.24 R=100.00
0.85% 105.00M	915.83	913.10	2.73	0.00	0.00	25.00	230+50	L=48.34
0.85% 105.00M	916.56	914.10	2.46	0.00	0.00	25.00	231	L=37.59 R=100.00
0.85% 105.00M	917.29	917.70	0.41	0.00	0.00	25.00	231+25	L=45.24 R=100.00
0.85% 105.00M	918.38	914.00	4.38	0.00	0.00	25.00	231+50	L=48.34
0.85% 105.00M	920.01	920.00	0.01	0.00	0.00	25.00	232	L=37.59 R=100.00
0.85% 105.00M	922.00	920.60	1.40	0.00	0.00	25.00	232+25	L=45.24 R=100.00
0.85% 105.00M	924.00	924.20	0.20	0.00	0.00	25.00	232+50	L=48.34
0.85% 105.00M	926.00	926.20	0.20	0.00	0.00	25.00	233	L=37.59 R=100.00
0.85% 105.00M	928.00	926.80	1.20	0.00	0.00	25.00	233+25	L=45.24 R=100.00
0.85% 105.00M	929.96	927.70	2.28	0.00	0.00	25.00	233+50	L=48.34
0.85% 105.00M	931.80	929.70	2.10	0.00	0.00	25.00	234	L=37.59 R=100.00
0.85% 105.00M	933.42	934.90	1.48	0.00	0.00	25.00	234+25	L=45.24 R=100.00
0.85% 105.00M	934.93	933.90	1.03	0.00	0.00	25.00	234+50	L=48.34
0.85% 105.00M	936.44	935.50	0.94	0.00	0.00	25.00	235	L=37.59 R=100.00

HIS MAJESTY'S GOVERNMENT OF NEPAL
 MINISTRY OF WORKS AND TRANSPORT
 DEPARTMENT OF ROADS
 AFTERCARE STUDY
 FOR
 SINDHULI ROAD CONSTRUCTION PROJECT
 PROFILE SECTION II-3
 SHEET NO. B-116
 SCALE: HOR. 1:2000 VER. 1:500
 DATE: _____
 JAPAN INTERNATIONAL COOPERATION AGENCY

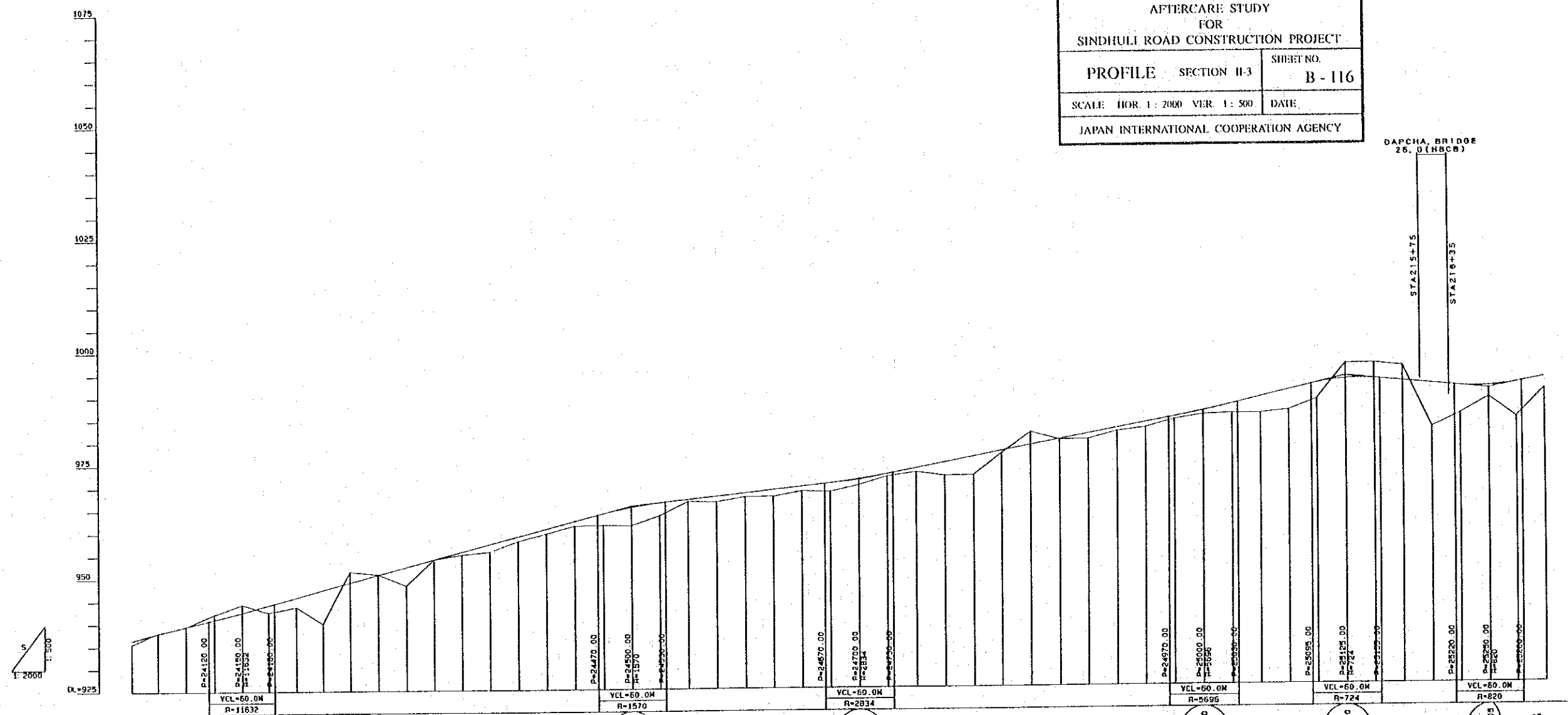

GRADE	PROPOSED HEIGHT	GROUND HEIGHT	CUTTING DEPTH	EMBANKMENT HEIGHT	ACCUMULATED DISTANCE	DISTANCE	STATION	CURVE ELEMENT
16.0556% 180.00M	938.44	935.60	0.84	0.84		25.00	240+50	L=150.55
	937.96	936.00	0.04			25.00	240+75	L=33.94
	939.47	938.40	0.07	0.07		25.00	241+00	L=33.94
942.50	940.99	942.10	1.11			25.00	241+25	L=33.94
	942.54	944.30	1.76	1.76		25.00	241+50	L=33.94
	944.14	942.50	1.84	1.84		25.00	241+75	L=33.94
	945.78	943.70	2.08	2.08		25.00	242+00	L=33.94
	947.43	938.90	7.53	7.53		25.00	242+25	L=33.94
	949.07	951.40	2.33	2.33		25.00	242+50	L=33.94
	950.71	950.90	0.09	0.09		25.00	242+75	L=33.94
	952.36	948.30	4.06	4.06		25.00	243+00	L=33.94
	954.00	954.00	0.00	0.00		25.00	243+25	L=33.94
	955.64	955.00	0.64	0.64		25.00	243+50	L=33.94
	957.29	955.60	1.69	1.69		25.00	243+75	L=33.94
	958.93	957.90	1.03	1.03		25.00	244+00	L=33.94
	960.57	959.90	1.07	1.07		25.00	244+25	L=33.94
	962.21	961.20	1.01	1.01		25.00	244+50	L=33.94
	963.85	961.30	2.55	2.55		25.00	244+75	L=33.94
	965.49	961.20	4.01	4.01		25.00	245+00	L=33.94
	967.13	963.30	2.89	2.89		25.00	245+25	L=33.94
	968.77	966.40	0.48	0.48		25.00	245+50	L=33.94
	970.41	966.30	1.26	1.26		25.00	245+75	L=33.94
	972.05	967.40	0.85	0.85		25.00	246+00	L=33.94
	973.69	967.40	1.54	1.54		25.00	246+25	L=33.94
	975.33	969.60	1.03	1.03		25.00	246+50	L=33.94
	976.97	968.40	1.51	1.51		25.00	246+75	L=33.94
	978.61	969.90	1.36	1.36		25.00	247+00	L=33.94
	980.25	971.70	0.82	0.82		25.00	247+25	L=33.94
	981.89	972.50	0.83	0.83		25.00	247+50	L=33.94
	983.53	971.70	2.95	2.95		25.00	247+75	L=33.94
	985.17	971.80	4.07	4.07		25.00	248+00	L=33.94
	986.81	976.50	0.59	0.59		25.00	248+25	L=33.94
	988.45	981.10	0.12	0.12		25.00	248+50	L=33.94
	990.09	979.40	1.23	1.23		25.00	248+75	L=33.94
	991.73	979.50	0.75	0.75		25.00	249+00	L=33.94
	993.37	981.20	1.17	1.17		25.00	249+25	L=33.94
	995.01	982.00	0.58	0.58		25.00	249+50	L=33.94
	996.65	984.38	0.88	0.88		25.00	249+75	L=33.94
	998.29	984.80	2.08	2.08		25.00	250+00	L=33.94
	1000.00	985.00	3.56	3.56		25.00	250+25	L=33.94
	1001.64	985.60	4.44	4.44		25.00	250+50	L=33.94
	1003.28	988.00	3.50	3.50		25.00	250+75	L=33.94
	1004.92	992.38	3.37	3.37		25.00	251+00	L=33.94
	1006.56	992.39	3.43	3.43		25.00	251+25	L=33.94
	1008.20	995.82	3.38	3.38		25.00	251+50	L=33.94
	1009.84	991.82	9.63	9.63		25.00	251+75	L=33.94
	1011.48	991.23	6.06	6.06		25.00	252+00	L=33.94
	1013.12	994.60	2.50	2.50		25.00	252+25	L=33.94
	1014.76	996.10	7.61	7.61		25.00	252+50	L=33.94
	1016.40	993.70	2.33	2.33		25.00	252+75	L=33.94
	1018.04	990.00	2.33	2.33		25.00	253+00	L=33.94

DAPCHA BRIDGE
 25.0 (HRCB)
 STA 215+75
 STA 216+35

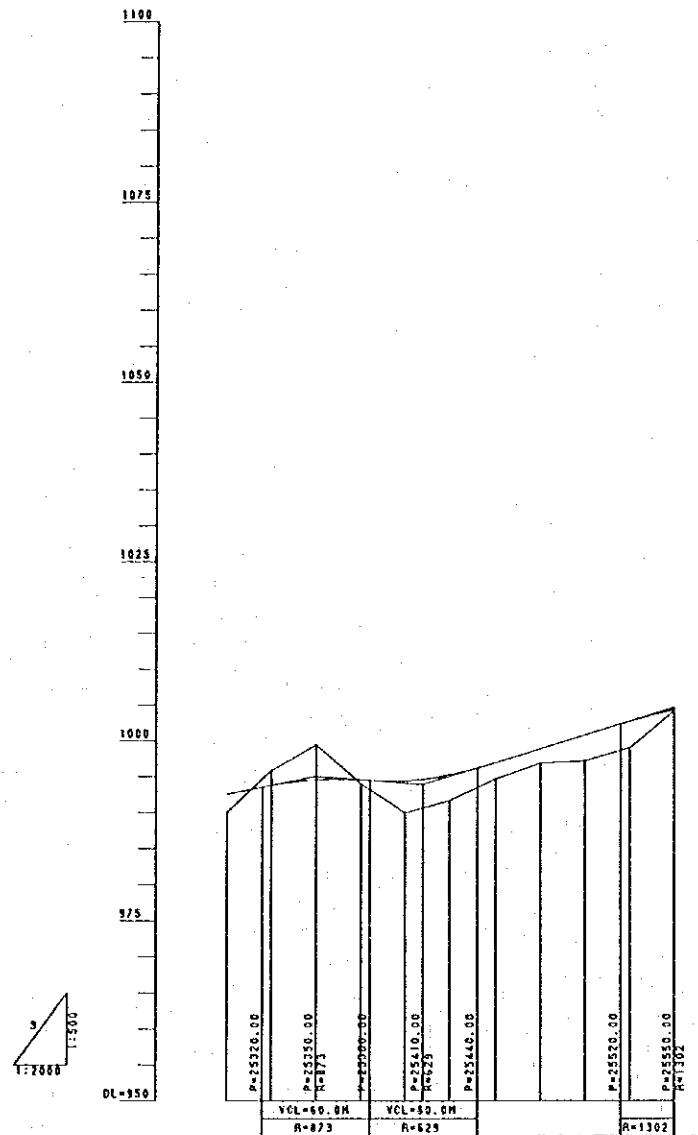

GRADE											
PROPOSED HEIGHT	992.53	993.75	994.48	994.51	994.36	995.17	996.02	996.79	1000.70	1002.59	1004.15
GROUND HEIGHT	990.00	995.00	999.40	993.90	989.90	991.60	994.60	996.00	997.10	998.90	1004.00
CUTTING DEPTH		2.05	4.92								
EMBANKMENT HEIGHT	2.53			0.61	4.46	3.57	2.29	1.99	3.60	3.69	0.15
ACCUMULATED DISTANCE											
DISTANCE	25.00	25.00	25.00	25.00	25.00	25.00	25.00	25.00	25.00	25.00	25.00
STATION	253	253+25	253+50	253+75	254	254+25	254+50	254+75	255	255+25	255+50
CURVE ELEMENT											

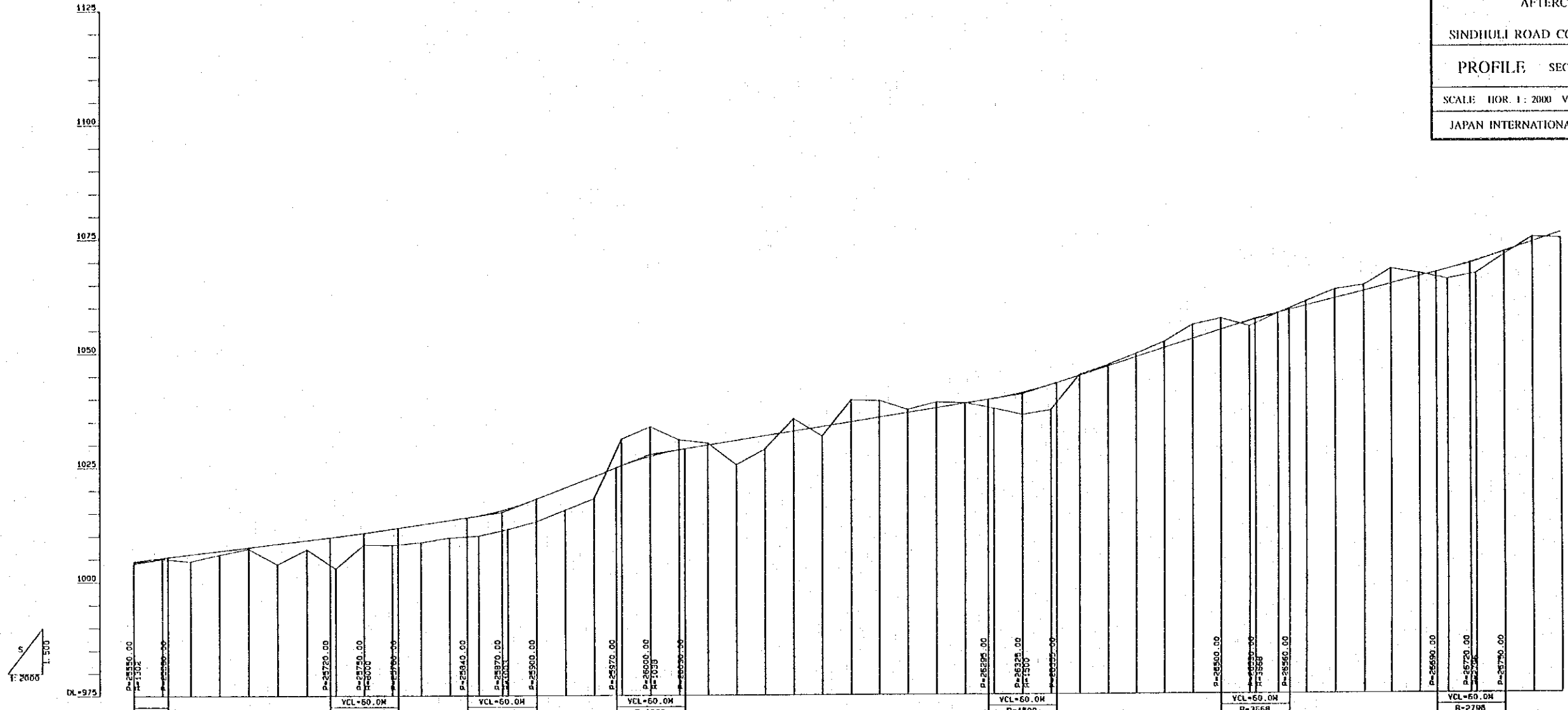

GRADE	PROPOSED HEIGHT	GROUND HEIGHT	CUTTING DEPTH	EMBANKMENT HEIGHT	ACCUMULATED DISTANCE	DISTANCE	STATION	CURVE ELEMENT
1004.50 +3.000% 200.00M	1004.15	1004.00	0.15	0.15	25.00	25.00	255+50	L-76.94 R-100.00
1005.24	1005.24	1005.00	0.24	0.24	25.00	25.00	255+75	L-33.35 L-33.35 R-100.00
1006.00	1006.00	1004.50	1.50	0.05	25.00	25.00	256+25	L-103.00 L-103.00 R-100.00
1006.75	1006.75	1005.50	1.25	0.30	25.00	25.00	256+50	L-33.35 R-100.00
1007.50	1007.50	1003.00	4.50	2.00	25.00	25.00	256+75	L-76.94 R-100.00
1008.25	1008.25	1007.00	1.25	6.95	25.00	25.00	257+25	L-103.00 L-76.94 R-100.00
1009.00	1009.00	1008.00	1.00	2.46	25.00	25.00	257+50	L-103.00 L-41.67 R-100.00
1010.56	1010.56	1007.50	3.06	3.54	25.00	25.00	257+75	L-103.00 L-76.94 R-100.00
1011.44	1011.44	1008.50	2.94	3.88	25.00	25.00	258	L-103.00 L-41.67 R-100.00
1012.39	1012.39	1009.50	2.89	3.81	25.00	25.00	258+25	L-103.00 L-76.94 R-100.00
1013.31	1013.31	1009.50	3.81	4.40	25.00	25.00	258+50	L-103.00 L-76.94 R-100.00
1014.30	1014.30	1011.00	3.30	4.50	25.00	25.00	258+75	L-103.00 L-76.94 R-100.00
1015.80	1015.80	1013.00	2.80	4.92	25.00	25.00	259+25	L-103.00 L-76.94 R-100.00
1017.92	1017.92	1015.50	2.42	4.65	25.00	25.00	259+50	L-103.00 L-76.94 R-100.00
1020.35	1020.35	1018.00	2.35	4.78	25.00	25.00	259+75	L-103.00 L-76.94 R-100.00
1022.78	1022.78	1031.00	1.22	4.92	25.00	25.00	260+25	L-103.00 L-76.94 R-100.00
1025.21	1025.21	1030.00	0.79	5.79	25.00	25.00	260+50	L-103.00 L-76.94 R-100.00
1027.65	1027.65	1033.70	0.60	6.48	25.00	25.00	261	L-103.00 L-76.94 R-100.00
1030.63	1030.63	1030.00	0.63	2.17	25.00	25.00	260+25	L-103.00 L-76.94 R-100.00
1033.59	1033.59	1030.00	3.59	0.47	25.00	25.00	260+50	L-103.00 L-76.94 R-100.00
1036.52	1036.52	1035.00	1.52	3.32	25.00	25.00	260+75	L-103.00 L-76.94 R-100.00
1039.55	1039.55	1038.70	0.85	2.90	25.00	25.00	261	L-103.00 L-76.94 R-100.00
1042.57	1042.57	1035.00	2.71	2.08	25.00	25.00	261+25	L-103.00 L-76.94 R-100.00
1045.58	1045.58	1033.50	2.08	2.08	25.00	25.00	261+50	L-103.00 L-76.94 R-100.00
1048.55	1048.55	1035.00	3.55	4.73	25.00	25.00	261+75	L-103.00 L-76.94 R-100.00
1051.55	1051.55	1039.20	2.35	3.64	25.00	25.00	262	L-103.00 L-76.94 R-100.00
1054.55	1054.55	1037.20	1.35	0.65	25.00	25.00	262+25	L-103.00 L-76.94 R-100.00
1057.53	1057.53	1038.80	0.73	1.27	25.00	25.00	262+50	L-103.00 L-76.94 R-100.00
1060.52	1060.52	1038.80	1.72	0.08	25.00	25.00	262+75	L-103.00 L-76.94 R-100.00
1063.52	1063.52	1037.40	2.12	2.12	25.00	25.00	263	L-103.00 L-76.94 R-100.00
1066.52	1066.52	1040.00	0.52	4.80	25.00	25.00	263+25	L-103.00 L-76.94 R-100.00
1069.50	1069.50	1037.00	2.50	5.50	25.00	25.00	263+50	L-103.00 L-76.94 R-100.00
1072.46	1072.46	1044.70	0.22	0.22	25.00	25.00	263+75	L-103.00 L-76.94 R-100.00
1075.44	1075.44	1046.80	0.34	0.34	25.00	25.00	264	L-103.00 L-76.94 R-100.00
1078.43	1078.43	1049.20	0.75	0.75	25.00	25.00	264+25	L-103.00 L-76.94 R-100.00
1081.41	1081.41	1051.80	1.36	1.36	25.00	25.00	264+50	L-103.00 L-76.94 R-100.00
1084.41	1084.41	1055.50	1.07	3.07	25.00	25.00	264+75	L-103.00 L-76.94 R-100.00
1087.41	1087.41	1058.90	1.49	2.49	25.00	25.00	265	L-103.00 L-76.94 R-100.00
1090.41	1090.41	1058.20	0.21	1.11	25.00	25.00	265+25	L-103.00 L-76.94 R-100.00
1093.41	1093.41	1058.00	0.41	0.05	25.00	25.00	265+50	L-103.00 L-76.94 R-100.00
1096.41	1096.41	1060.50	0.91	0.96	25.00	25.00	265+75	L-103.00 L-76.94 R-100.00
1099.41	1099.41	1063.20	1.21	1.98	25.00	25.00	266	L-103.00 L-76.94 R-100.00
1102.41	1102.41	1064.10	0.81	1.30	25.00	25.00	266+25	L-103.00 L-76.94 R-100.00
1105.41	1105.41	1067.70	0.73	3.32	25.00	25.00	266+50	L-103.00 L-76.94 R-100.00
1108.41	1108.41	1068.70	0.74	0.74	25.00	25.00	266+75	L-103.00 L-76.94 R-100.00
1111.41	1111.41	1065.40	2.16	2.16	25.00	25.00	267	L-103.00 L-76.94 R-100.00
1114.41	1114.41	1066.60	2.73	2.73	25.00	25.00	267+25	L-103.00 L-76.94 R-100.00
1117.41	1117.41	1070.70	0.71	0.64	25.00	25.00	267+50	L-103.00 L-76.94 R-100.00
1120.41	1120.41	1074.50	1.05	1.05	25.00	25.00	267+75	L-103.00 L-76.94 R-100.00
1123.41	1123.41	1074.30	1.27	1.27	25.00	25.00	268	L-103.00 L-76.94 R-100.00

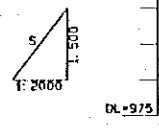

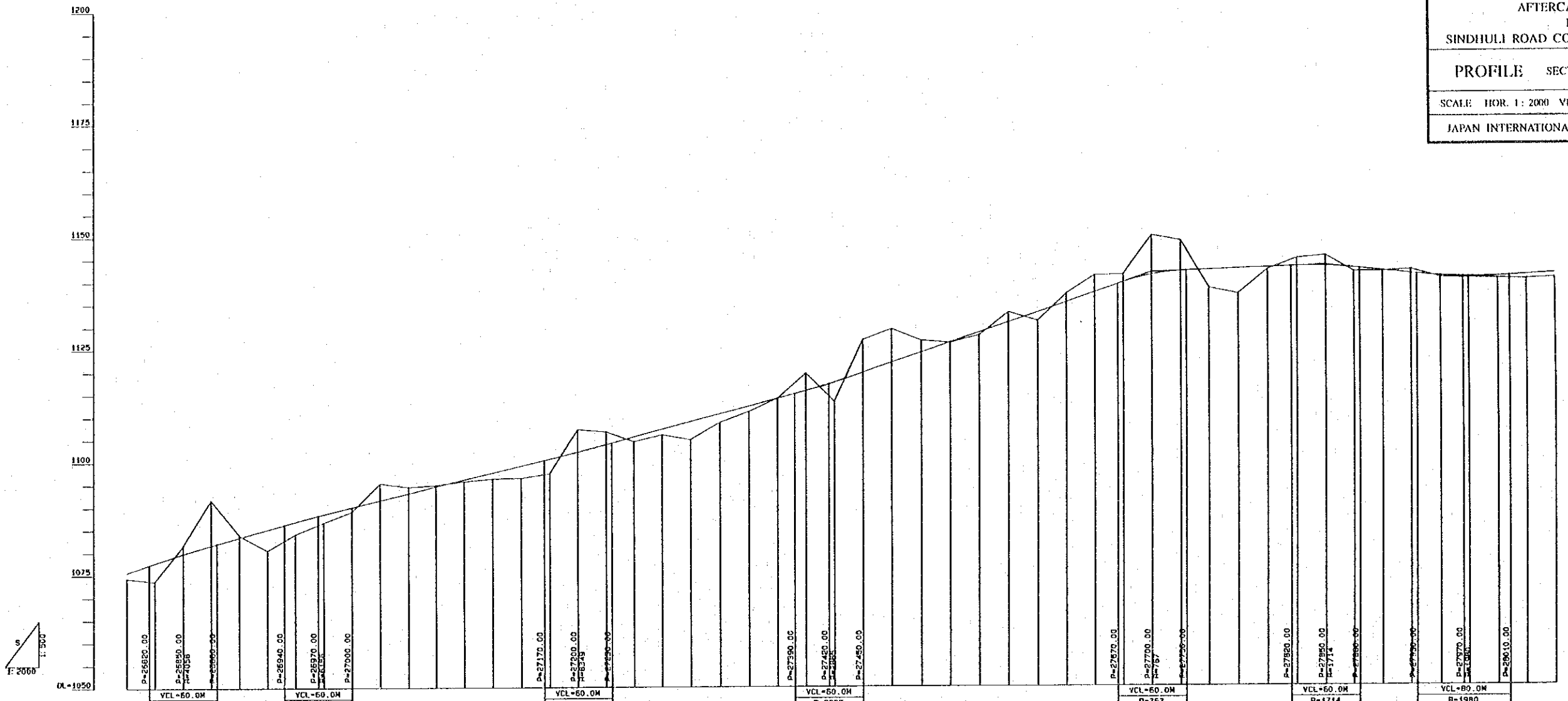

GRADE	PROPOSED HEIGHT	GROUND HEIGHT	CUTTING DEPTH	EMBANKMENT HEIGHT	ACCUMULATED DISTANCE	DISTANCE	STATION	CURVE ELEMENT
+6.4615% 130.00M	1075.57	1074.30	1.27	1.27		25.00	266	L=20.00 R=100.00 P=25850.00
+6.9833% 100.00M	1077.69	1073.60	4.08	4.08		25.00	268+25	L=20.00 R=100.00 P=25850.00
	1079.69	1081.50	1.81			25.00	268+50	L=20.00 R=100.00 P=25850.00
	1081.53	1081.60	0.07			25.00	268+75	L=20.00 R=100.00 P=25850.00
	1083.29	1083.80	0.51			25.00	269	L=20.00 R=100.00 P=25850.00
	1085.04	1085.04	0.00	4.54		25.00	269+25	L=20.00 R=100.00 P=25850.00
	1086.77	1084.00	2.77	2.77		25.00	269+50	L=20.00 R=100.00 P=25850.00
	1088.43	1086.60	1.83	1.83		25.00	269+75	L=20.00 R=100.00 P=25850.00
	1089.98	1089.00	0.98	0.98		25.00	270	L=20.00 R=100.00 P=25850.00
	1091.48	1091.20	0.28			25.00	270+25	L=20.00 R=100.00 P=25850.00
	1092.99	1094.40	1.41			25.00	270+50	L=20.00 R=100.00 P=25850.00
	1094.49	1094.80	0.31			25.00	270+75	L=20.00 R=100.00 P=25850.00
	1095.99	1095.60	0.39	0.39		25.00	271	L=20.00 R=100.00 P=25850.00
	1097.49	1096.20	1.29	1.29		25.00	271+25	L=20.00 R=100.00 P=25850.00
	1099.00	1096.30	2.70	2.70		25.00	271+50	L=20.00 R=100.00 P=25850.00
	1100.50	1097.30	3.20	3.20		25.00	271+75	L=20.00 R=100.00 P=25850.00
	1102.05	1107.00	4.95			25.00	272	L=20.00 R=100.00 P=25850.00
	1103.68	1106.50	2.82			25.00	272+25	L=20.00 R=100.00 P=25850.00
	1105.36	1104.30	1.06	1.06		25.00	272+50	L=20.00 R=100.00 P=25850.00
	1107.05	1105.80	1.25	1.25		25.00	272+75	L=20.00 R=100.00 P=25850.00
	1108.73	1104.70	4.03	4.03		25.00	273	L=20.00 R=100.00 P=25850.00
	1110.41	1108.50	1.91	1.91		25.00	273+25	L=20.00 R=100.00 P=25850.00
	1112.09	1110.90	1.19	1.19		25.00	273+50	L=20.00 R=100.00 P=25850.00
	1113.77	1113.80	0.03			25.00	273+75	L=20.00 R=100.00 P=25850.00
	1115.47	1119.30	3.83			25.00	274	L=20.00 R=100.00 P=25850.00
	1117.25	1113.00	4.25	4.25		25.00	274+25	L=20.00 R=100.00 P=25850.00
	1119.43	1126.70	7.23			25.00	274+50	L=20.00 R=100.00 P=25850.00
	1121.65	1129.10	7.45			25.00	274+75	L=20.00 R=100.00 P=25850.00
	1123.86	1126.90	2.64			25.00	275	L=20.00 R=100.00 P=25850.00
	1126.06	1126.00	0.06	0.06		25.00	275+25	L=20.00 R=100.00 P=25850.00
	1128.27	1127.60	0.67	0.67		25.00	275+50	L=20.00 R=100.00 P=25850.00
	1130.47	1132.70	2.23			25.00	275+75	L=20.00 R=100.00 P=25850.00
	1132.68	1130.90	1.78	1.78		25.00	276	L=20.00 R=100.00 P=25850.00
	1134.88	1136.90	1.92			25.00	276+25	L=20.00 R=100.00 P=25850.00
	1137.09	1140.90	3.71			25.00	276+50	L=20.00 R=100.00 P=25850.00
	1139.27	1141.00	1.73			25.00	276+75	L=20.00 R=100.00 P=25850.00
	1141.50	1148.60	8.69			25.00	277	L=20.00 R=100.00 P=25850.00
	1143.73	1148.90	6.77			25.00	277+25	L=20.00 R=100.00 P=25850.00
	1146.00	1148.00	1.98			25.00	277+50	L=20.00 R=100.00 P=25850.00
	1148.25	1136.70	1.53			25.00	277+75	L=20.00 R=100.00 P=25850.00
	1142.50	1142.00	0.50	0.50		25.00	278	L=20.00 R=100.00 P=25850.00
	1144.74	1144.30	0.44			25.00	278+25	L=20.00 R=100.00 P=25850.00
	1147.00	1145.10	1.90			25.00	278+50	L=20.00 R=100.00 P=25850.00
	1149.25	1141.60	3.65			25.00	278+75	L=20.00 R=100.00 P=25850.00
	1151.50	1141.60	0.00			25.00	279	L=20.00 R=100.00 P=25850.00
	1153.75	1142.00	1.75			25.00	279+25	L=20.00 R=100.00 P=25850.00
	1156.00	1140.20	2.80			25.00	279+50	L=20.00 R=100.00 P=25850.00
	1158.25	1140.10	3.15			25.00	279+75	L=20.00 R=100.00 P=25850.00
	1160.50	1139.90	0.60			25.00	280	L=20.00 R=100.00 P=25850.00
	1162.75	1140.20	2.55			25.00	280+25	L=20.00 R=100.00 P=25850.00
	1165.00	1140.00	1.00			25.00	280+50	L=20.00 R=100.00 P=25850.00

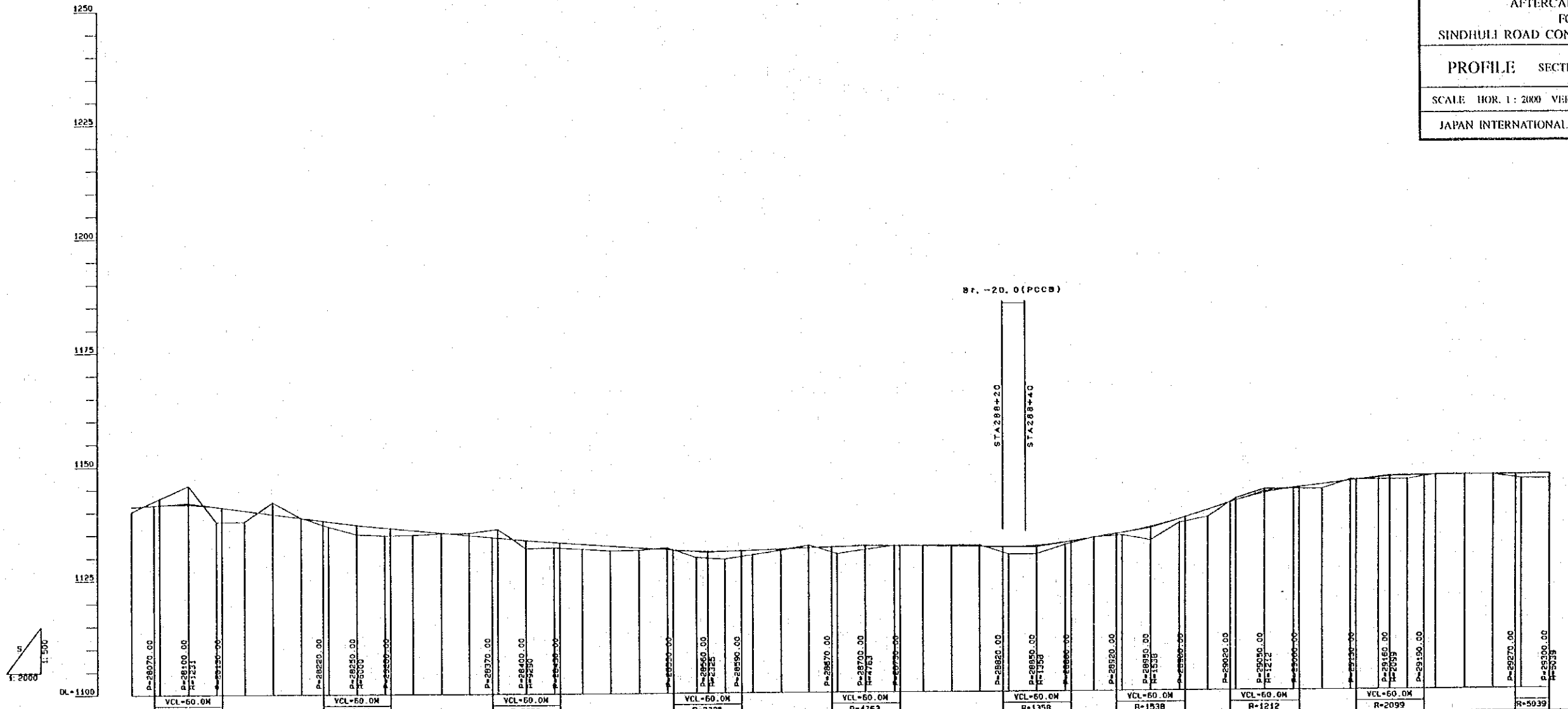

GRADE	PROPOSED HEIGHT	GROUND HEIGHT	CUTTING DEPTH	EMBANKMENT HEIGHT	ACCUMULATED DISTANCE	DISTANCE	STATION	CURVE ELEMENT
+1.5305% 130.00M	1141.22	1140.20	1.03	1.03		25.00	280+00	L=35.59 R=100.00
-3.3333% 150.00M	1141.51	1143.00	1.39	1.39		25.00	280+75	L=35.59 R=100.00
	1141.53	1145.90	4.17	3.36		25.00	281	L=35.59 R=100.00
	1141.16	1137.80	1.13	2.43		25.00	281+25	L=35.59 R=100.00
	1140.33	1137.90	2.43	2.43		25.00	281+50	L=35.59 R=100.00
	1139.50	1142.10	2.60	2.60		25.00	281+75	L=35.59 R=100.00
	1138.67	1138.70	0.03	1.13		25.00	282	L=35.59 R=100.00
	1137.83	1136.70	1.13	2.08		25.00	282+25	L=35.59 R=100.00
	1137.08	1135.00	2.08	1.72		25.00	282+50	L=35.59 R=100.00
	1136.42	1134.70	1.72	1.03		25.00	282+75	L=35.59 R=100.00
	1135.63	1134.80	1.03	0.15		25.00	283	L=35.59 R=100.00
	1135.25	1135.10	0.15	0.15		25.00	283+25	L=35.59 R=100.00
	1134.57	1135.20	0.53	1.75		25.00	283+50	L=35.59 R=100.00
	1134.08	1136.00	1.92	1.18		25.00	283+75	L=35.59 R=100.00
	1133.55	1131.80	1.75	1.08		25.00	284	L=35.59 R=100.00
	1133.08	1131.90	1.18	1.03		25.00	284+25	L=35.59 R=100.00
	1132.86	1131.50	1.08	1.03		25.00	284+50	L=35.59 R=100.00
	1132.23	1131.20	1.03	0.51		25.00	284+75	L=35.59 R=100.00
	1131.81	1131.30	0.51	1.36		25.00	285	L=35.59 R=100.00
	1131.39	1131.80	0.41	1.68		25.00	285+25	L=35.59 R=100.00
	1131.06	1129.70	1.36	1.68		25.00	285+50	L=35.59 R=100.00
	1130.98	1120.30	1.68	0.96		25.00	285+75	L=35.59 R=100.00
	1130.16	1130.20	0.04	0.28		25.00	286	L=35.59 R=100.00
	1131.38	1131.10	0.28	1.53		25.00	286+25	L=35.59 R=100.00
	1131.50	1132.20	0.60	0.75		25.00	286+50	L=35.59 R=100.00
	1131.83	1130.30	1.53	0.75		25.00	286+75	L=35.59 R=100.00
	1131.96	1131.20	0.76	1.83		25.00	287	L=35.59 R=100.00
	1131.87	1132.00	0.13	0.52		25.00	287+25	L=35.59 R=100.00
	1131.77	1132.00	0.23	1.60		25.00	287+50	L=35.59 R=100.00
	1131.68	1132.00	0.32	1.83		25.00	287+75	L=35.59 R=100.00
	1131.50	1130.00	1.50	1.83		25.00	288	L=35.59 R=100.00
	1131.83	1130.00	1.83	0.52		25.00	288+25	L=35.59 R=100.00
	1132.02	1132.00	0.02	0.25		25.00	288+50	L=35.59 R=100.00
	1133.83	1133.50	0.33	0.25		25.00	288+75	L=35.59 R=100.00
	1134.85	1134.00	0.85	0.25		25.00	289	L=35.59 R=100.00
	1135.64	1132.90	2.74	0.25		25.00	289+25	L=35.59 R=100.00
	1137.35	1135.70	1.65	1.23		25.00	289+50	L=35.59 R=100.00
	1139.53	1138.00	1.53	0.24		25.00	289+75	L=35.59 R=100.00
	1141.50	1142.00	0.50	1.00		25.00	290	L=35.59 R=100.00
	1143.13	1144.00	0.87	0.40		25.00	290+25	L=35.59 R=100.00
	1144.24	1144.00	0.24	0.77		25.00	290+50	L=35.59 R=100.00
	1145.00	1144.00	1.00	0.40		25.00	290+75	L=35.59 R=100.00
	1145.75	1146.00	0.25	0.77		25.00	291	L=35.59 R=100.00
	1146.40	1146.00	0.40	0.40		25.00	291+25	L=35.59 R=100.00
	1146.77	1146.00	0.77	0.24		25.00	291+50	L=35.59 R=100.00
	1146.86	1147.00	0.14	0.24		25.00	291+75	L=35.59 R=100.00
	1146.89	1147.00	0.11	0.24		25.00	292	L=35.59 R=100.00
	1146.93	1147.00	0.07	0.24		25.00	292+25	L=35.59 R=100.00
	1146.96	1146.90	0.06	0.24		25.00	292+50	L=35.59 R=100.00
	1147.09	1146.00	1.09	0.24		25.00	292+75	L=35.59 R=100.00
	1147.00	1146.00	1.00	0.24		25.00	293	L=35.59 R=100.00

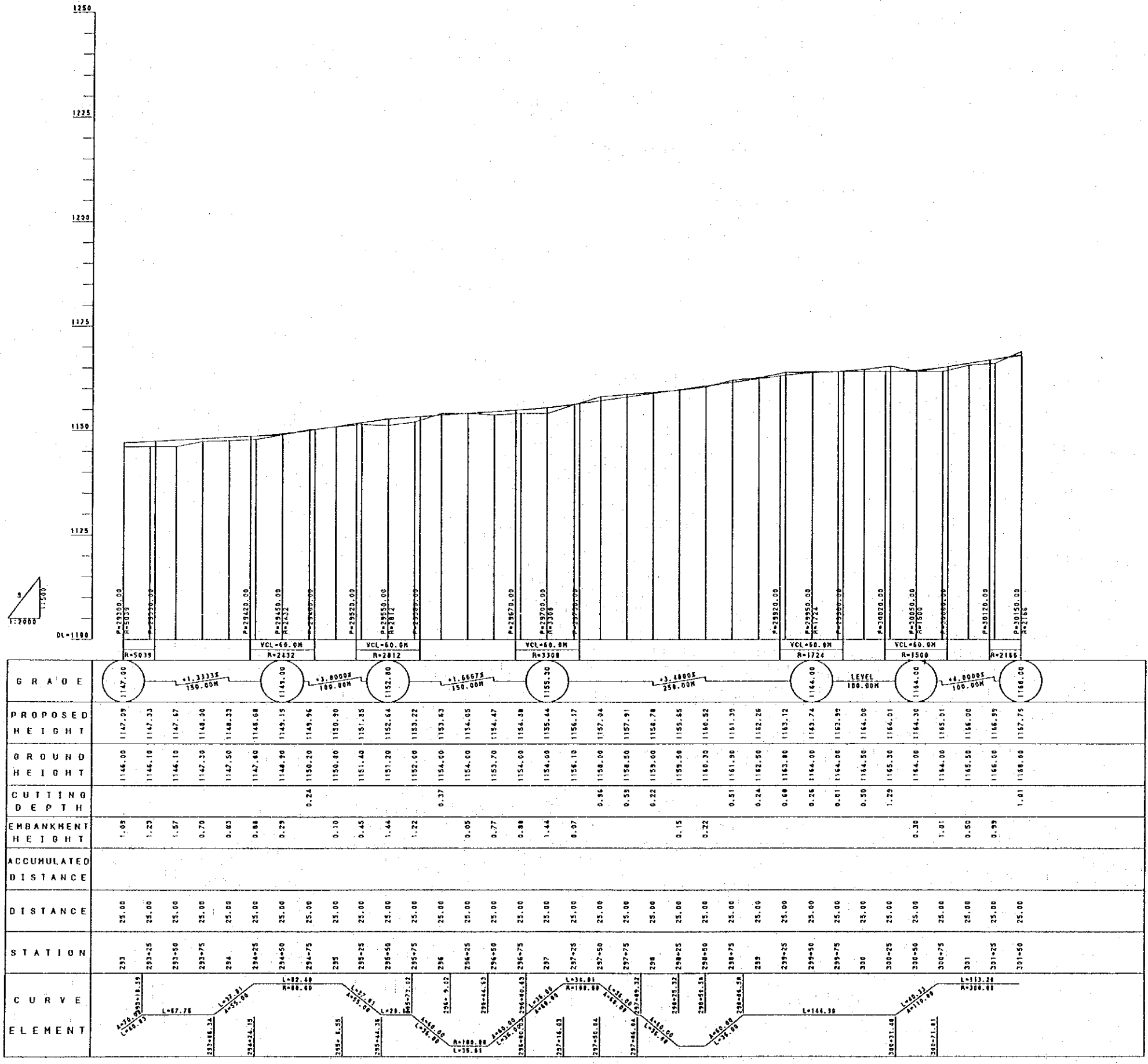

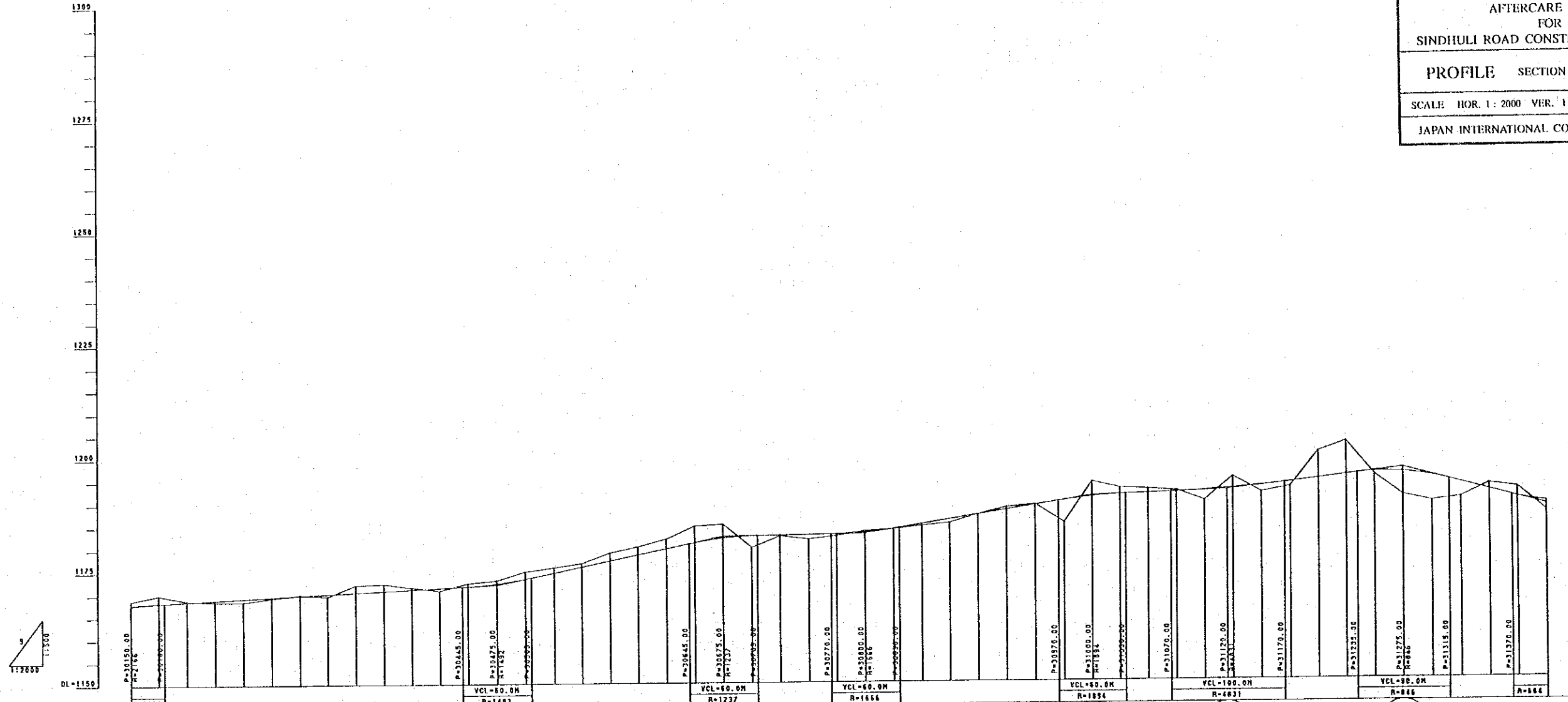

GRADE	PROPOSED HEIGHT	GROUND HEIGHT	CUTTING DEPTH	EMBANKMENT HEIGHT	ACCUMULATED DISTANCE	DISTANCE	STATION	CURVE ELEMENT
1168.00	1167.79	1168.60	1.01			25.00	301+50	
1168.00	1168.30	1170.00	1.70			25.00	301+75	
1168.00	1168.62	1168.60	0.18	0.42		25.00	302	
1168.50	1168.92	1168.50	0.42			25.00	302+25	
1168.50	1169.23	1168.50	0.73	0.73		25.00	302+50	
1169.30	1169.54	1169.30	0.24	0.24		25.00	302+75	
1170.00	1169.85	1170.00	0.15	0.55		25.00	303	
1170.15	1170.15	1169.60	0.55			25.00	303+25	
1170.46	1170.46	1172.10	1.64	0.58		25.00	303+50	
1170.77	1170.77	1172.30	1.53			25.00	303+75	
1171.08	1171.08	1171.50	0.42			25.00	304	
1171.70	1171.70	1170.80	0.90			25.00	304+25	
1172.00	1172.00	1172.40	0.40			25.00	304+50	
1172.30	1172.30	1173.00	0.70			25.00	304+75	
1173.32	1173.32	1174.50	1.18			25.00	305	
1174.63	1174.63	1175.80	1.17			25.00	305+25	
1175.94	1175.94	1176.70	0.76			25.00	305+50	
1177.25	1177.25	1179.00	1.75			25.00	305+75	
1178.56	1178.56	1180.30	1.74			25.00	306	
1179.89	1179.89	1182.00	2.12			25.00	306+25	
1181.18	1181.18	1184.80	3.62			25.00	306+50	
1182.14	1182.14	1185.20	3.06			25.00	306+75	
1182.59	1182.59	1186.00	3.41	2.53		25.00	307	
1182.70	1182.70	1182.50	0.20	0.20		25.00	307+25	
1182.80	1182.80	1181.80	1.00	1.00		25.00	307+50	
1183.27	1183.27	1182.50	0.77	0.41		25.00	307+75	
1184.01	1184.01	1183.50	0.51	0.11		25.00	308	
1185.00	1185.00	1184.60	0.40	0.40		25.00	308+25	
1186.00	1186.00	1185.20	0.80	0.80		25.00	308+50	
1187.00	1187.00	1187.00	0.00	0.00		25.00	308+75	
1188.00	1188.00	1189.10	1.10			25.00	309	
1189.39	1189.39	1185.10	4.29	4.89		25.00	309+25	
1190.76	1190.76	1194.00	3.24			25.00	309+50	
1191.20	1191.20	1192.60	1.40			25.00	309+75	
1191.42	1191.42	1192.30	0.88			25.00	310	
1191.82	1191.82	1191.90	0.08			25.00	310+25	
1191.92	1191.92	1189.70	2.22	2.22		25.00	310+50	
1192.35	1192.35	1194.00	1.65	1.51		25.00	311	
1193.60	1193.60	1193.60	0.00	1.00		25.00	311+25	
1194.32	1194.32	1206.30	12.98	5.28		25.00	311+50	
1195.05	1195.05	1202.40	7.35	7.35		25.00	311+75	
1195.64	1195.64	1195.00	0.64	0.64		25.00	312	
1195.55	1195.55	1190.50	5.05	5.05		25.00	312+25	
1196.73	1196.73	1189.20	7.53	5.53		25.00	312+50	
1197.22	1197.22	1190.00	7.22	3.22		25.00	312+75	
1197.57	1197.57	1192.10	5.47	5.47		25.00	313	
1198.97	1198.97	1186.90	12.07	2.07		25.00	313+25	
1199.27	1199.27	1188.90	10.37			25.00	313+50	
1199.27	1199.27	1188.90	10.37			25.00	313+75	
1199.27	1199.27	1188.90	10.37			25.00	314	

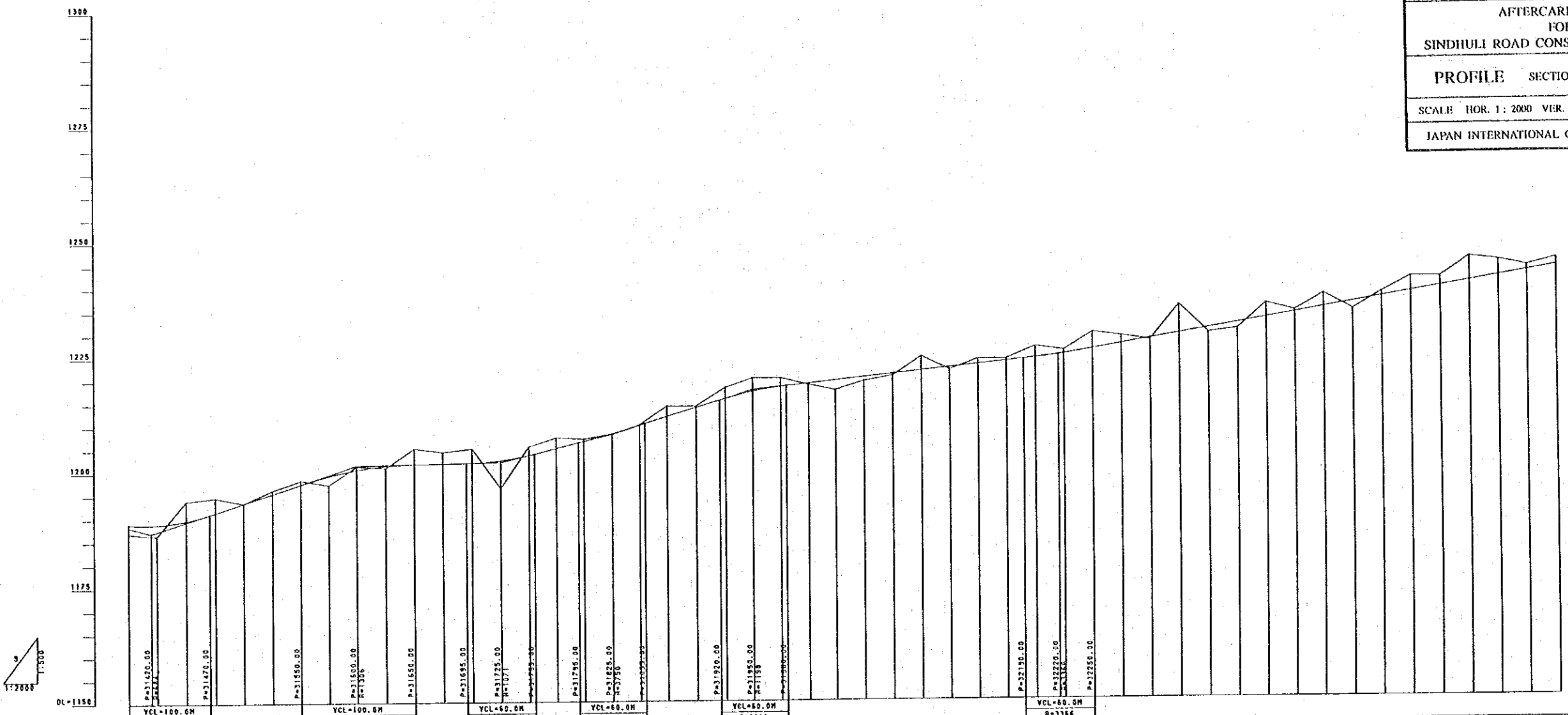

GRADE	PROPOSED HEIGHT	GROUND HEIGHT	CUTTING DEPTH	EMBANKMENT HEIGHT	ACCUMULATED DISTANCE	DISTANCE	STATION	CURVE ELEMENT
1186.90	1189.97	1186.90	2.07			25.00	314	
1186.40	1188.88	1186.40	2.48			25.00	314+25	
1192.90	1189.71	1192.90	4.19			25.00	314+50	
1194.60	1191.43	1194.60	3.17			25.00	314+75	
1193.40	1193.44	1193.40	0.04			25.00	315	
1196.20	1195.46	1196.20	0.74			25.00	315+25	
1196.30	1197.47	1196.30	0.83			25.00	315+50	
1197.30	1199.25	1197.30	1.95			25.00	315+75	
1201.30	1200.54	1201.30	0.76			25.00	316	
1200.90	1201.36	1200.90	0.46			25.00	316+25	
1205.10	1201.70	1205.10	3.40			25.00	316+50	
1204.30	1201.80	1204.30	2.50			25.00	316+75	
1205.00	1201.91	1205.00	3.09			25.00	317	
1196.40	1202.42	1196.40	6.02			25.00	317+25	
1205.40	1203.51	1205.40	1.89			25.00	317+50	
1207.30	1205.00	1207.30	2.30			25.00	317+75	
1207.00	1206.50	1207.00	0.50			25.00	318	
1208.00	1206.12	1208.00	0.12			25.00	318+25	
1210.00	1209.80	1210.00	0.10			25.00	318+50	
1214.00	1211.88	1214.00	2.20			25.00	318+75	
1214.00	1213.70	1214.00	0.30			25.00	319	
1218.00	1215.89	1218.00	2.41			25.00	319+25	
1220.00	1217.12	1220.00	2.88			25.00	319+50	
1220.00	1218.14	1220.00	1.86			25.00	319+75	
1218.50	1218.60	1218.50	0.30			25.00	320	
1217.30	1219.44	1217.30	2.14			25.00	320+25	
1219.20	1220.09	1219.20	0.89			25.00	320+50	
1220.30	1220.74	1220.30	0.44			25.00	320+75	
1224.40	1221.39	1224.40	3.01			25.00	321	
1221.50	1222.64	1221.50	0.54			25.00	321+25	
1223.80	1222.69	1223.80	1.11			25.00	321+50	
1223.80	1223.33	1223.80	0.47			25.00	321+75	
1226.40	1223.98	1226.40	2.41			25.00	322	
1225.60	1224.81	1225.60	0.79			25.00	322+25	
1229.40	1225.81	1229.40	3.59			25.00	322+50	
1228.60	1226.91	1228.60	1.69			25.00	322+75	
1227.70	1228.00	1227.70	0.30			25.00	323	
1235.20	1229.09	1235.20	6.11			25.00	323+25	
1229.20	1230.19	1229.20	0.99			25.00	323+50	
1230.00	1231.28	1230.00	1.28			25.00	323+75	
1235.40	1232.38	1235.40	3.02			25.00	324	
1233.90	1233.47	1233.90	0.43			25.00	324+25	
1237.40	1234.56	1237.40	2.84			25.00	324+50	
1234.10	1235.66	1234.10	1.56			25.00	324+75	
1237.70	1236.75	1237.70	0.95			25.00	325	
1241.00	1237.84	1241.00	3.16			25.00	325+25	
1241.00	1238.94	1241.00	2.08			25.00	325+50	
1245.20	1240.03	1245.20	5.17			25.00	325+75	
1244.50	1241.13	1244.50	3.97			25.00	326	
1243.30	1242.22	1243.30	1.08			25.00	326+25	
1244.90	1243.31	1244.90	1.59			25.00	326+50	

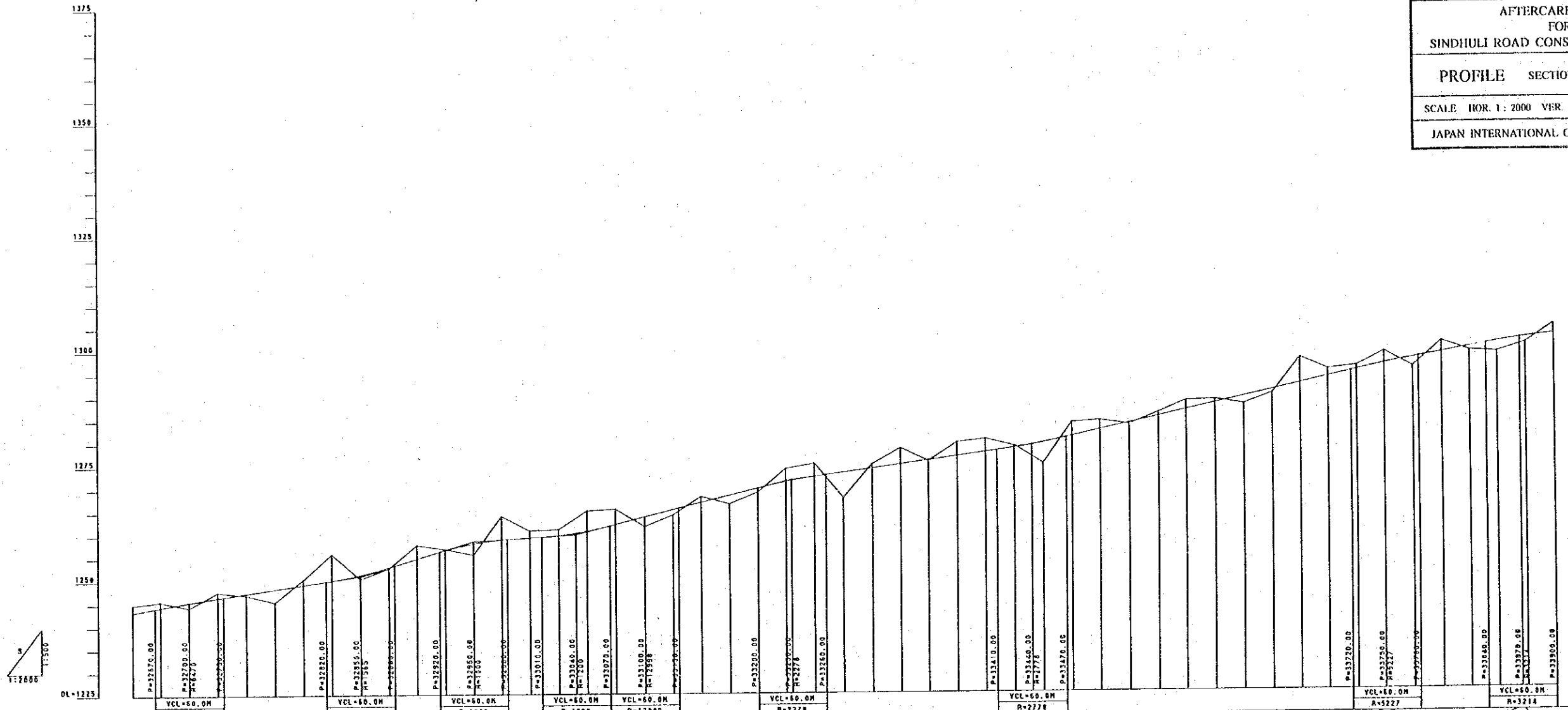

GRADE	PROPOSED HEIGHT	GROUND HEIGHT	CUTTING DEPTH	EMBANKMENT HEIGHT	ACCUMULATED DISTANCE	DISTANCE	STATION	CURVE ELEMENT
+1.3750X 60.00M	1243.31	1244.90	1.59			25.00	326+50	L=80.86
1245.50	1244.41	1245.60	1.19			25.00	326+75	
+3.8667X 150.00M	1246.42	1244.30	1.16	1.15		25.00	327	L=37.12, 1.18
1251.00	1247.33	1246.90	0.43			25.00	327+25	L=37.12, 1.18
+7.5000X 180.00M	1248.25	1245.40	2.85			25.00	327+50	L=37.12, 1.18
1258.50	1249.17	1249.30	1.13			25.00	328	L=37.12, 1.18
1258.50	1250.09	1255.80	5.71			25.00	328+25	L=37.12, 1.18
1258.50	1251.29	1255.40	0.69			25.00	329	L=37.12, 1.18
1258.50	1252.49	1252.70	0.18			25.00	329+25	L=37.12, 1.18
1258.50	1254.75	1257.70	2.95			25.00	329+50	L=37.12, 1.18
1258.50	1256.42	1256.00	0.42			25.00	330	L=37.12, 1.18
1258.50	1258.07	1264.00	5.93			25.00	330+25	L=37.12, 1.18
1258.50	1260.67	1260.60	0.07			25.00	331	L=37.12, 1.18
1258.50	1262.13	1265.10	2.97			25.00	331+25	L=37.12, 1.18
1258.50	1263.72	1261.60	2.12			25.00	331+50	L=37.12, 1.18
1258.50	1265.26	1264.10	1.16			25.00	332	L=37.12, 1.18
1258.50	1266.77	1266.00	0.77			25.00	332+25	L=37.12, 1.18
1258.50	1268.29	1266.40	1.89			25.00	333	L=37.12, 1.18
1258.50	1269.79	1268.90	0.89			25.00	333+25	L=37.12, 1.18
1258.50	1271.16	1274.00	2.84			25.00	334	L=37.12, 1.18
1258.50	1272.26	1275.10	2.84			25.00	334+25	L=37.12, 1.18
1258.50	1273.13	1267.60	5.53			25.00	335	L=37.12, 1.18
1258.50	1273.98	1274.90	0.92			25.00	335+25	L=37.12, 1.18
1258.50	1274.83	1278.30	3.47			25.00	336	L=37.12, 1.18
1258.50	1275.63	1275.50	0.13			25.00	336+25	L=37.12, 1.18
1258.50	1276.28	1276.70	0.42			25.00	337	L=37.12, 1.18
1258.50	1279.39	1274.00	5.39			25.00	337+25	L=37.12, 1.18
1258.50	1280.70	1283.70	3.00			25.00	338	L=37.12, 1.18
1258.50	1282.03	1284.10	2.07			25.00	338+25	L=37.12, 1.18
1258.50	1283.49	1283.20	0.29			25.00	339	L=37.12, 1.18
1258.50	1284.87	1285.70	0.83			25.00	339+25	L=37.12, 1.18
1258.50	1286.26	1288.20	1.94			25.00	340	L=37.12, 1.18
1258.50	1287.55	1286.40	1.15			25.00	340+25	L=37.12, 1.18
1258.50	1288.04	1287.40	0.64			25.00	341	L=37.12, 1.18
1258.50	1289.44	1289.70	0.26			25.00	341+25	L=37.12, 1.18
1258.50	1291.83	1297.30	5.47			25.00	342	L=37.12, 1.18
1258.50	1293.22	1294.80	1.58			25.00	342+25	L=37.12, 1.18
1258.50	1294.61	1295.50	0.89			25.00	343	L=37.12, 1.18
1258.50	1295.91	1298.50	2.59			25.00	343+25	L=37.12, 1.18
1258.50	1297.10	1295.20	1.90			25.00	344	L=37.12, 1.18
1258.50	1298.21	1300.60	2.39			25.00	344+25	L=37.12, 1.18
1258.50	1299.31	1298.50	0.81			25.00	345	L=37.12, 1.18
1258.50	1300.48	1298.20	2.28			25.00	345+25	L=37.12, 1.18
1258.50	1301.33	1300.10	1.23			25.00	346	L=37.12, 1.18
1258.50	1302.07	1304.20	2.13			25.00	346+25	L=37.12, 1.18

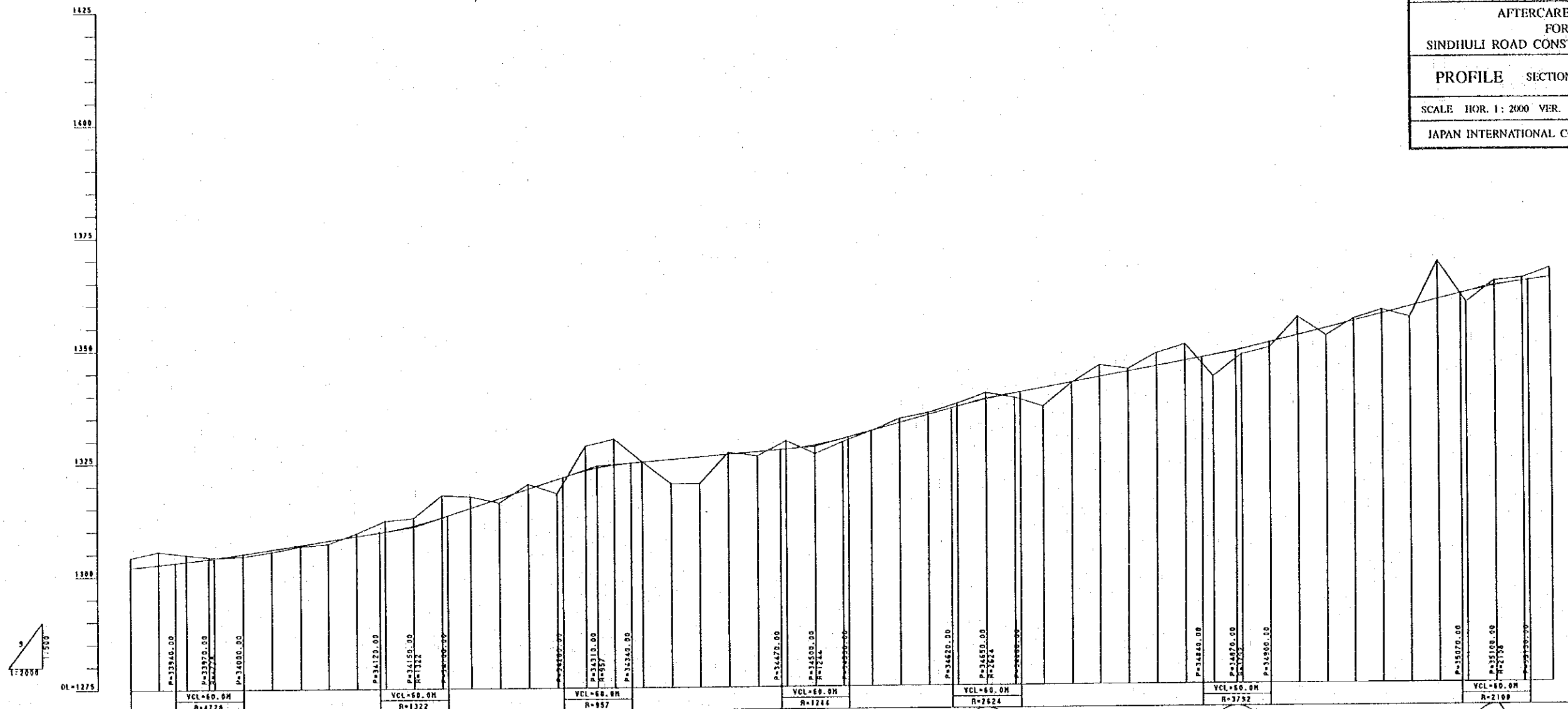

GRADE	PROPOSED HEIGHT	GROUND HEIGHT	CUTTING DEPTH	EMBANKMENT HEIGHT	ACCUMULATED DISTANCE	DISTANCE	STATION	CURVE ELEMENT
+2.95000 160.00M	1302.07	1304.20	2.13	0.59		25.00	335	R=33945.00 L=25.00
1303.35	1302.70	1305.60	2.90	0.54		25.00	339	R=33945.00 L=25.00
+3.80558 180.00M	1303.35	1304.60	1.45	0.29		25.00	339	R=33945.00 L=25.00
1304.11	1304.11	1304.20	0.09	0.75		25.00	340	R=33945.00 L=25.00
1304.99	1304.99	1304.40	0.59	0.54		25.00	340	R=33945.00 L=25.00
1305.94	1305.94	1305.40	0.54	0.29		25.00	340	R=33945.00 L=25.00
1306.89	1306.89	1306.60	0.29	0.75		25.00	340	R=33945.00 L=25.00
1307.85	1307.85	1307.10	0.75			25.00	341	R=33945.00 L=25.00
1308.80	1308.80	1309.40	0.60			25.00	341	R=33945.00 L=25.00
1309.76	1309.76	1312.10	2.34			25.00	341	R=33945.00 L=25.00
1311.04	1311.04	1312.70	1.66			25.00	341	R=33945.00 L=25.00
1312.83	1312.83	1317.70	4.90			25.00	341	R=33945.00 L=25.00
1314.87	1314.87	1317.40	2.53			25.00	342	R=33945.00 L=25.00
1316.96	1316.96	1316.00	0.96			25.00	342	R=33945.00 L=25.00
1319.04	1319.04	1320.10	1.06			25.00	342	R=33945.00 L=25.00
1321.13	1321.13	1318.00	3.13			25.00	342	R=33945.00 L=25.00
1323.01	1323.01	1328.50	5.49			25.00	343	R=33945.00 L=25.00
1324.24	1324.24	1330.00	5.76			25.00	343	R=33945.00 L=25.00
1324.88	1324.88	1324.00	0.88			25.00	343	R=33945.00 L=25.00
1325.40	1325.40	1320.00	5.40			25.00	343	R=33945.00 L=25.00
1325.92	1325.92	1326.00	0.08			25.00	344	R=33945.00 L=25.00
1326.44	1326.44	1325.00	1.44			25.00	344	R=33945.00 L=25.00
1326.96	1326.96	1326.00	0.96			25.00	344	R=33945.00 L=25.00
1327.49	1327.49	1329.30	1.81			25.00	344	R=33945.00 L=25.00
1328.00	1328.00	1328.40	0.40			25.00	345	R=33945.00 L=25.00
1328.56	1328.56	1329.00	0.44			25.00	345	R=33945.00 L=25.00
1329.07	1329.07	1329.74	0.67			25.00	345	R=33945.00 L=25.00
1329.58	1329.58	1331.40	1.82			25.00	345	R=33945.00 L=25.00
1330.09	1330.09	1334.10	4.01			25.00	345	R=33945.00 L=25.00
1330.60	1330.60	1335.30	4.70			25.00	345	R=33945.00 L=25.00
1331.11	1331.11	1337.20	6.09			25.00	345	R=33945.00 L=25.00
1331.62	1331.62	1338.60	7.00			25.00	345	R=33945.00 L=25.00
1332.13	1332.13	1339.10	7.00			25.00	345	R=33945.00 L=25.00
1332.64	1332.64	1339.50	6.86			25.00	346	R=33945.00 L=25.00
1333.15	1333.15	1336.50	3.35			25.00	346	R=33945.00 L=25.00
1333.66	1333.66	1341.70	8.04			25.00	346	R=33945.00 L=25.00
1334.17	1334.17	1345.50	11.33			25.00	346	R=33945.00 L=25.00
1334.68	1334.68	1344.12	0.56			25.00	347	R=33945.00 L=25.00
1335.19	1335.19	1348.10	2.91			25.00	347	R=33945.00 L=25.00
1335.70	1335.70	1345.27	2.83			25.00	348	R=33945.00 L=25.00
1336.21	1336.21	1350.00	3.79			25.00	348	R=33945.00 L=25.00
1336.72	1336.72	1346.42	0.30			25.00	348	R=33945.00 L=25.00
1337.23	1337.23	1342.90	4.33			25.00	348	R=33945.00 L=25.00
1337.74	1337.74	1347.59	4.85			25.00	348	R=33945.00 L=25.00
1338.25	1338.25	1346.89	1.36			25.00	349	R=33945.00 L=25.00
1338.76	1338.76	1349.20	2.44			25.00	349	R=33945.00 L=25.00
1339.27	1339.27	1350.36	1.09			25.00	349	R=33945.00 L=25.00
1339.78	1339.78	1355.90	5.62			25.00	349	R=33945.00 L=25.00
1340.29	1340.29	1351.97	1.68			25.00	349	R=33945.00 L=25.00
1340.80	1340.80	1351.00	0.80			25.00	349	R=33945.00 L=25.00
1341.31	1341.31	1355.50	4.19			25.00	349	R=33945.00 L=25.00
1341.82	1341.82	1355.01	0.49			25.00	349	R=33945.00 L=25.00
1342.33	1342.33	1357.40	2.47			25.00	349	R=33945.00 L=25.00
1342.84	1342.84	1355.80	0.70			25.00	350	R=33945.00 L=25.00
1343.35	1343.35	1358.10	2.75			25.00	350	R=33945.00 L=25.00
1343.86	1343.86	1366.00	12.14			25.00	350	R=33945.00 L=25.00
1344.37	1344.37	1359.30	0.63			25.00	350	R=33945.00 L=25.00
1344.88	1344.88	1362.54	3.66			25.00	350	R=33945.00 L=25.00
1345.39	1345.39	1363.70	1.16			25.00	351	R=33945.00 L=25.00
1345.90	1345.90	1364.38	0.48			25.00	351	R=33945.00 L=25.00
1346.41	1346.41	1366.50	2.09			25.00	351	R=33945.00 L=25.00
1346.92	1346.92	1364.43	2.49			25.00	351	R=33945.00 L=25.00

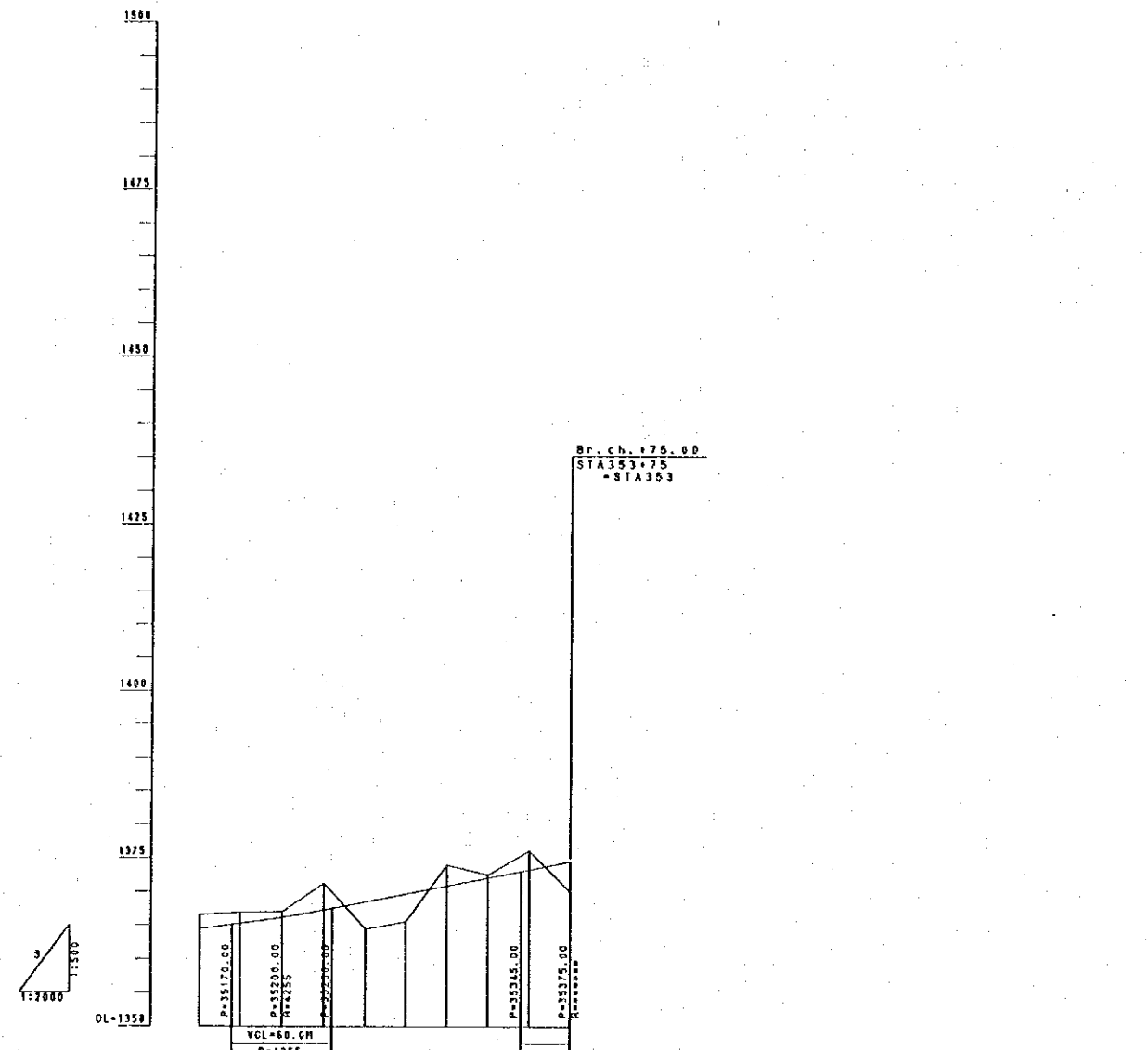

GRADE	+3.3500% 100.00M		+1.7500% 175.00M							
PROPOSED HEIGHT	1364.43	1365.26	1366.21	1367.23	1368.48	1369.67	1370.86	1372.05	1373.24	1374.43
GROUND HEIGHT	1366.00	1366.00	1367.00	1371.20	1364.40	1365.50	1373.90	1372.50	1376.00	1370.00
CUTTING DEPTH	2.07	1.64	0.79	3.91	0.08	4.17	3.04	0.45	2.76	4.43
EMBANKMENT HEIGHT					4.08	4.17				4.43
ACCUMULATED DISTANCE										
DISTANCE	25.00	25.00	25.00	25.00	25.00	25.00	25.00	25.00	25.00	25.00
STATION	351+50	351+75	352	352+25	352+50	352+75	353	353+25	353+50	353+75
CURVE ELEMENT	351+51.37	351+76.25	352+13.28	352+38.12	352+63.00	352+87.88	353+12.06	353+36.94	353+61.82	353+86.70

HIS MAJESTY'S GOVERNMENT OF NEPAL
 MINISTRY OF WORKS AND TRANSPORT
 DEPARTMENT OF ROADS

AFTERCARE STUDY
 FOR
 SINDHULI ROAD CONSTRUCTION PROJECT

PROFILE SECTION II-3
 SHEET NO. B - 127

SCALE HOR. 1: 2000 VER. 1: 500
 DATE

JAPAN INTERNATIONAL COOPERATION AGENCY

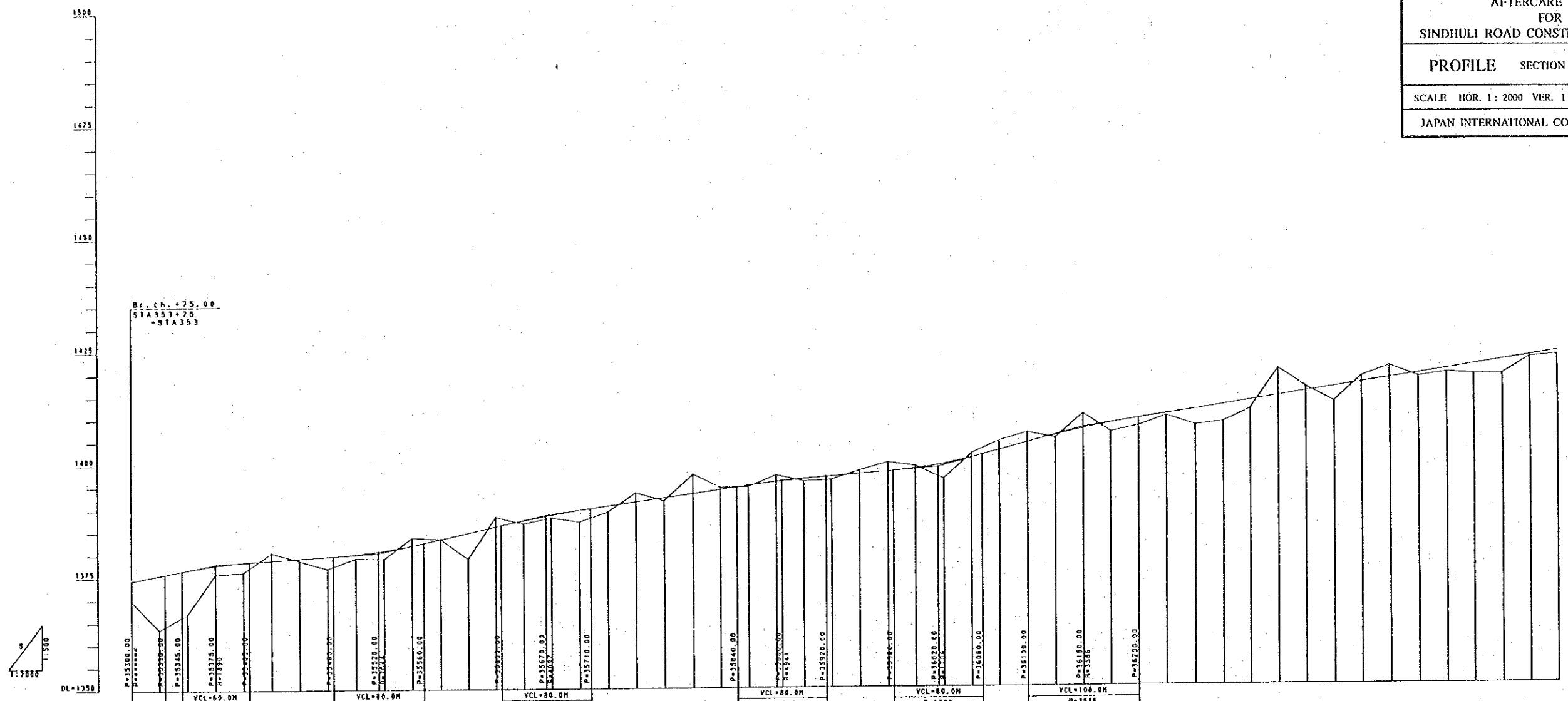

GRADE	PROPOSED HEIGHT	GROUND HEIGHT	CUTTING DEPTH	EMBANKMENT HEIGHT	ACCUMULATED DISTANCE	DISTANCE	STATION	CURVE ELEMENT
1374.43	1374.43	1376.00	1.57	4.43		25.00	353	L=81.31
1375.62	1375.62	1363.50	1.12	12.12		25.00	353+25	L=49.97 R=29.88
1376.80	1376.80	1367.00	0.80	9.80		25.00	353+50	L=49.97 R=29.88
1377.74	1377.74	1375.80	1.94	1.94		25.00	353+75	L=49.97 R=29.88
1378.39	1378.39	1376.20	2.19	2.19		25.00	354	L=49.97 R=29.88
1378.79	1378.79	1380.50	1.71	0.45	1.71	25.00	354+25	L=49.97 R=29.88
1379.19	1379.19	1378.70	0.49	0.49		25.00	354+50	L=49.97 R=29.88
1379.59	1379.59	1376.90	2.69	2.69		25.00	354+75	L=49.97 R=29.88
1380.08	1380.08	1379.20	0.88	0.88		25.00	355	L=49.97 R=29.88
1380.58	1380.58	1379.00	1.58	1.58		25.00	355+25	L=49.97 R=29.88
1381.97	1381.97	1382.70	0.73	0.73	1.73	25.00	355+50	L=49.97 R=29.88
1383.33	1383.33	1382.40	0.93	0.93		25.00	355+75	L=49.97 R=29.88
1384.70	1384.70	1378.90	5.80	5.80		25.00	356	L=49.97 R=29.88
1386.08	1386.08	1388.20	2.12	0.70	2.12	25.00	356+25	L=49.97 R=29.88
1387.40	1387.40	1386.70	0.70	0.70		25.00	356+50	L=49.97 R=29.88
1388.58	1388.58	1388.00	0.58	0.58		25.00	356+75	L=49.97 R=29.88
1389.60	1389.60	1387.00	2.60	2.60		25.00	357	L=49.97 R=29.88
1391.29	1391.29	1399.20	1.30	1.30		25.00	357+25	L=49.97 R=29.88
1392.27	1392.27	1391.50	0.67	0.67	2.01	25.00	357+50	L=49.97 R=29.88
1393.16	1393.16	1397.40	4.24	4.24		25.00	357+75	L=49.97 R=29.88
1394.05	1394.05	1394.50	0.45	0.45		25.00	358	L=49.97 R=29.88
1394.93	1394.93	1394.60	0.33	0.33		25.00	358+25	L=49.97 R=29.88
1395.78	1395.78	1397.20	1.20	1.20		25.00	358+50	L=49.97 R=29.88
1396.33	1396.33	1395.80	0.53	0.53		25.00	358+75	L=49.97 R=29.88
1396.87	1396.87	1396.10	0.77	0.77		25.00	359	L=49.97 R=29.88
1397.35	1397.35	1398.10	0.75	0.75		25.00	359+25	L=49.97 R=29.88
1397.83	1397.83	1399.80	1.97	1.97		25.00	359+50	L=49.97 R=29.88
1398.43	1398.43	1399.00	0.57	0.57		25.00	359+75	L=49.97 R=29.88
1399.33	1399.33	1398.10	1.23	1.23		25.00	360	L=49.97 R=29.88
1400.71	1400.71	1401.66	0.95	0.95		25.00	360+25	L=49.97 R=29.88
1402.24	1402.24	1404.40	2.16	2.16		25.00	360+50	L=49.97 R=29.88
1403.99	1403.99	1406.20	2.21	2.21		25.00	360+75	L=49.97 R=29.88
1405.56	1405.56	1404.90	0.66	0.66		25.00	361	L=49.97 R=29.88
1406.17	1406.17	1410.20	4.03	4.03		25.00	361+25	L=49.97 R=29.88
1406.21	1406.21	1407.50	1.29	1.29		25.00	361+50	L=49.97 R=29.88
1406.17	1406.17	1409.70	3.53	3.53		25.00	361+75	L=49.97 R=29.88
1406.17	1406.17	1407.60	1.43	1.43		25.00	362	L=49.97 R=29.88
1406.17	1406.17	1407.60	1.43	1.43		25.00	362+25	L=49.97 R=29.88
1406.17	1406.17	1407.60	1.43	1.43		25.00	362+50	L=49.97 R=29.88
1406.17	1406.17	1408.30	2.13	2.13		25.00	362+75	L=49.97 R=29.88
1406.17	1406.17	1411.10	4.93	4.93		25.00	363	L=49.97 R=29.88
1406.17	1406.17	1420.00	8.83	8.83		25.00	363+25	L=49.97 R=29.88
1406.17	1406.17	1415.90	5.73	5.73		25.00	363+50	L=49.97 R=29.88
1406.17	1406.17	1422.60	6.43	6.43		25.00	363+75	L=49.97 R=29.88
1406.17	1406.17	1418.20	5.97	5.97		25.00	364	L=49.97 R=29.88
1406.17	1406.17	1420.40	4.23	4.23		25.00	364+25	L=49.97 R=29.88
1406.17	1406.17	1418.70	6.47	6.47		25.00	364+50	L=49.97 R=29.88
1406.17	1406.17	1419.74	6.43	6.43		25.00	364+75	L=49.97 R=29.88
1406.17	1406.17	1418.60	7.57	7.57		25.00	365	L=49.97 R=29.88
1406.17	1406.17	1418.20	7.97	7.97		25.00	365+25	L=49.97 R=29.88
1406.17	1406.17	1421.65	5.52	5.52		25.00	365+50	L=49.97 R=29.88
1406.17	1406.17	1422.61	6.44	6.44		25.00	365+75	L=49.97 R=29.88
1406.17	1406.17	1423.56	7.39	7.39		25.00	366	L=49.97 R=29.88

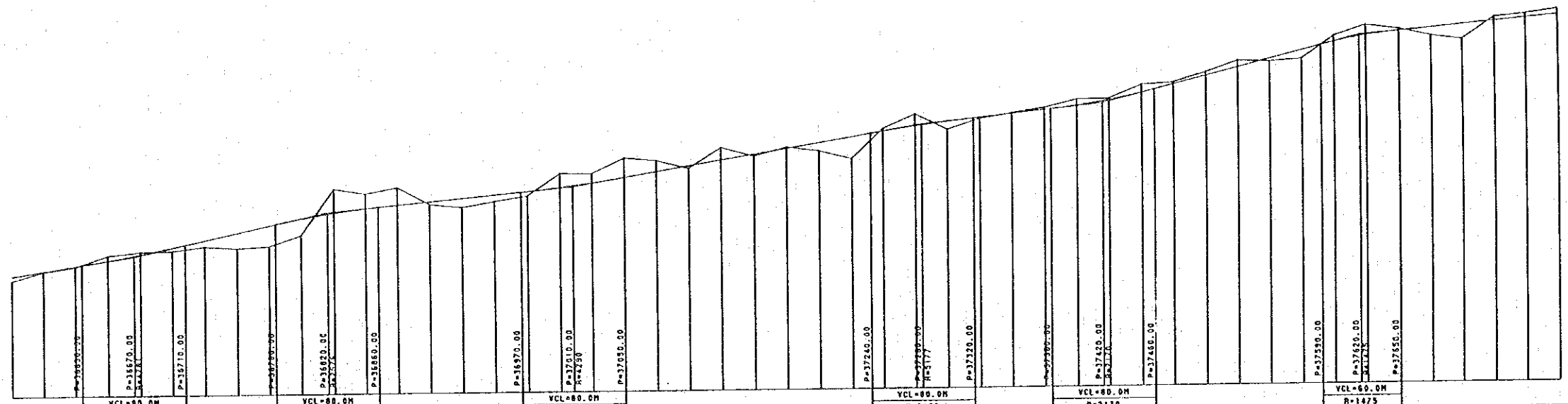
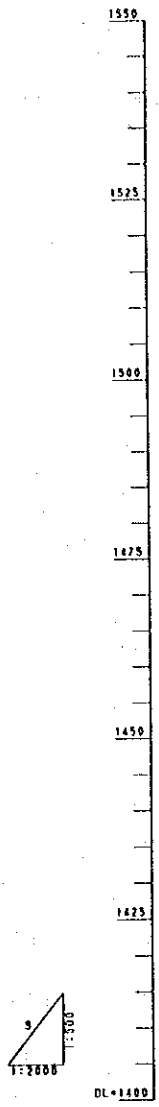

GRADE	PROPOSED HEIGHT	GROUND HEIGHT	CUTTING DEPTH	EMBANKMENT HEIGHT	ACCUMULATED DISTANCE	DISTANCE	STATION	CURVE ELEMENT
+3.8759% 520.00M	1423.56	1422.70	0.86	0.86		25.00	365+75	R=4781
1427.20	1424.32	1424.40	0.12	0.12		25.00	366	
+5.5800% 150.00M	1425.48	1425.30	0.18	0.18		25.00	366+25	
1427.61	1426.47	1427.40	0.93	0.93		25.00	366+50	
1428.86	1428.10	1428.10	0.45	0.45		25.00	366+75	
1432.27	1428.20	1428.20	0.66	0.66		25.00	367	
1435.33	1429.00	1429.00	1.23	1.23		25.00	367+25	
1436.15	1429.60	1429.60	3.00	3.00		25.00	367+50	
1437.37	1429.90	1429.90	4.08	4.08		25.00	367+75	
1440.00	1431.00	1431.00	3.27	3.27		25.00	368	
1441.70	1440.00	1440.00	4.67	4.67		25.00	368+25	
1443.83	1439.00	1439.00	2.85	2.85		25.00	368+50	
1445.96	1440.20	1440.20	3.43	3.43		25.00	368+75	
1447.03	1436.20	1436.20	0.57	0.57		25.00	369	
1448.71	1437.30	1437.30	1.76	1.76		25.00	369+25	
1451.17	1438.80	1438.80	1.26	1.26		25.00	369+50	
1452.72	1438.30	1438.30	0.86	0.86		25.00	369+75	
1453.40	1442.80	1442.80	2.74	2.74		25.00	370	
1454.08	1442.50	1442.50	1.79	1.79		25.00	370+25	
1455.30	1445.50	1445.50	3.80	3.80		25.00	370+50	
1455.90	1444.90	1444.90	2.13	2.13		25.00	370+75	
1457.24	1443.30	1443.30	0.53	0.53		25.00	371	
1458.82	1447.30	1447.30	2.40	2.40		25.00	371+25	
1460.42	1445.60	1445.60	0.38	0.38		25.00	371+50	
1462.02	1446.50	1446.50	1.59	1.59		25.00	372	
1463.82	1446.90	1446.90	4.25	4.25		25.00	372+25	
1465.22	1450.70	1450.70	0.45	0.45		25.00	372+50	
1466.78	1451.17	1451.17	2.33	2.33		25.00	372+75	
1468.00	1450.40	1450.40	1.60	1.60		25.00	373	
1469.01	1452.00	1452.00	0.22	0.22		25.00	373+25	
1470.55	1452.72	1452.72	0.16	0.16		25.00	373+50	
1471.13	1453.40	1453.40	0.42	0.42		25.00	373+75	
1471.72	1454.08	1454.08	1.25	1.25		25.00	374	
1472.86	1454.85	1454.85	0.30	0.30		25.00	374+25	
1473.38	1455.30	1455.30	1.56	1.56		25.00	374+50	
1475.00	1456.20	1456.20	0.38	0.38		25.00	374+75	
1476.55	1457.24	1457.24	0.88	0.88		25.00	375	
1477.13	1458.82	1458.82	1.28	1.28		25.00	375+25	
1477.72	1460.42	1460.42	0.52	0.52		25.00	375+50	
1478.97	1462.02	1462.02	1.72	1.72		25.00	375+75	
1480.00	1463.82	1463.82	1.11	1.11		25.00	376	
1481.13	1465.22	1465.22	1.89	1.89		25.00	376+25	
1482.86	1466.78	1466.78	0.40	0.40		25.00	376+50	
1485.97	1468.00	1468.00	1.58	1.58		25.00	376+75	
1487.13	1469.01	1469.01	2.97	2.97		25.00	377	
1488.00	1469.97	1469.97	0.75	0.75		25.00	377+25	
1489.38	1470.55	1470.55	0.77	0.77		25.00	377+50	
1490.00	1471.13	1471.13	1.06	1.06		25.00	377+75	
1491.13	1472.86	1472.86				25.00	378	

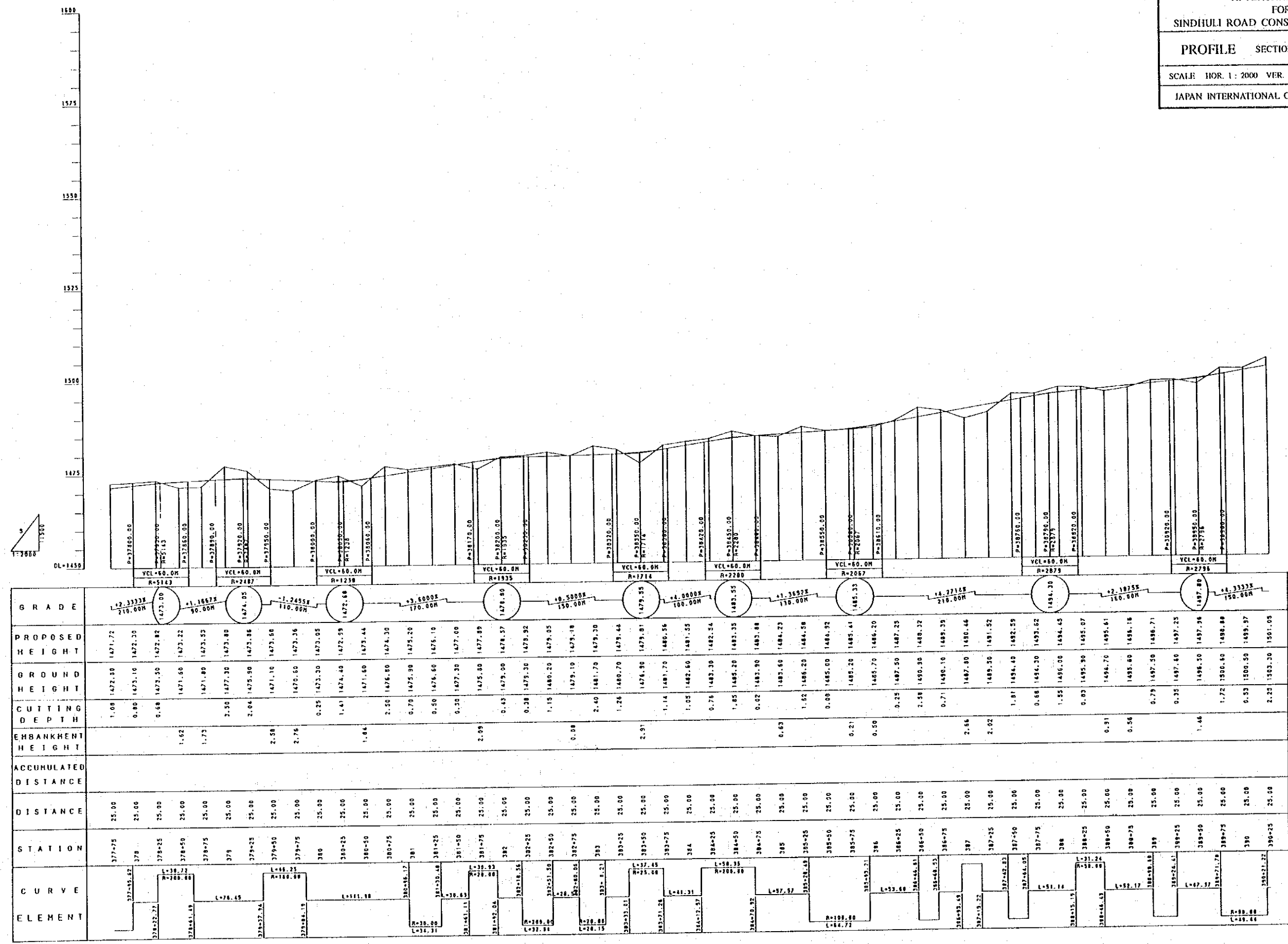

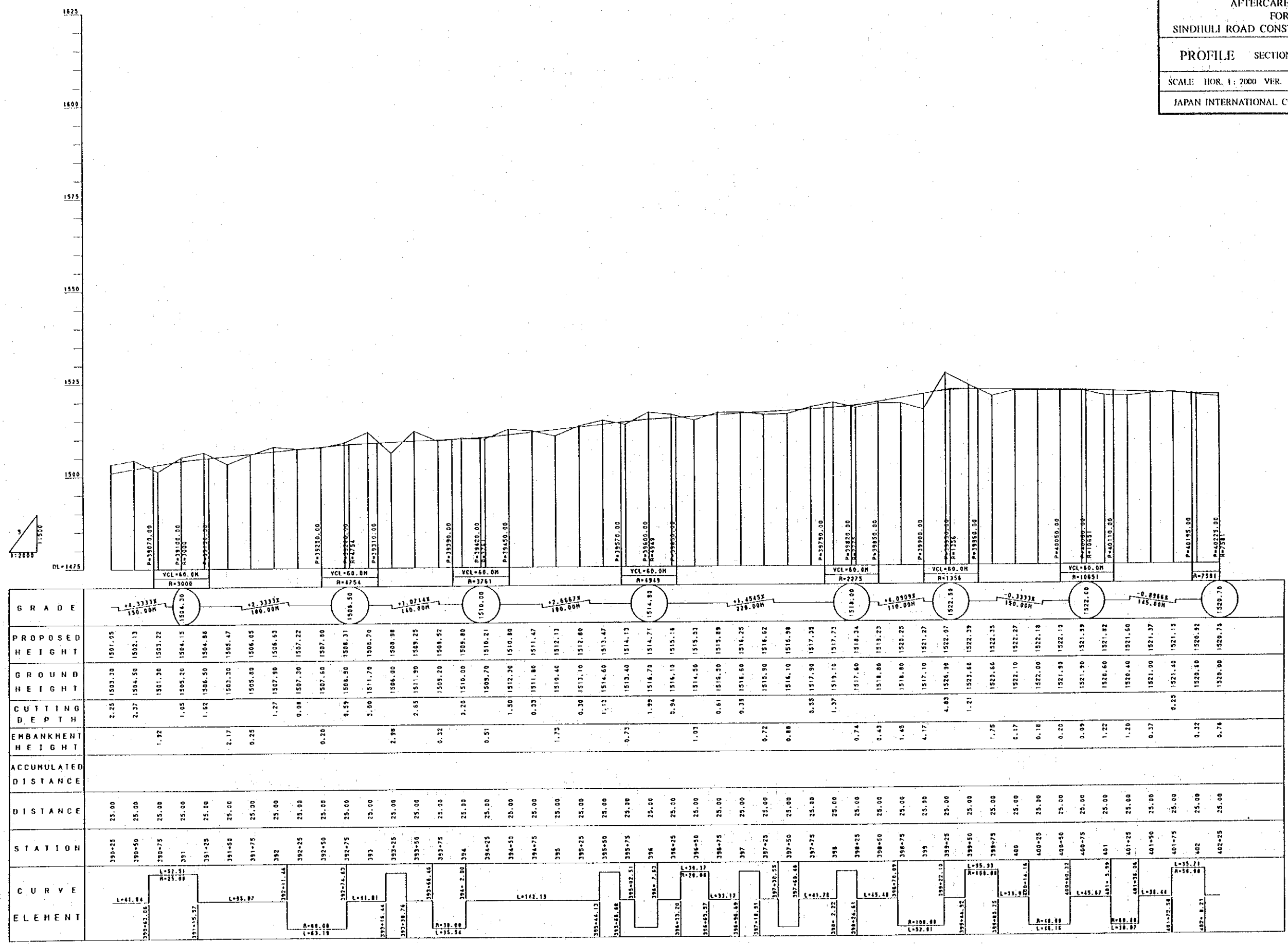

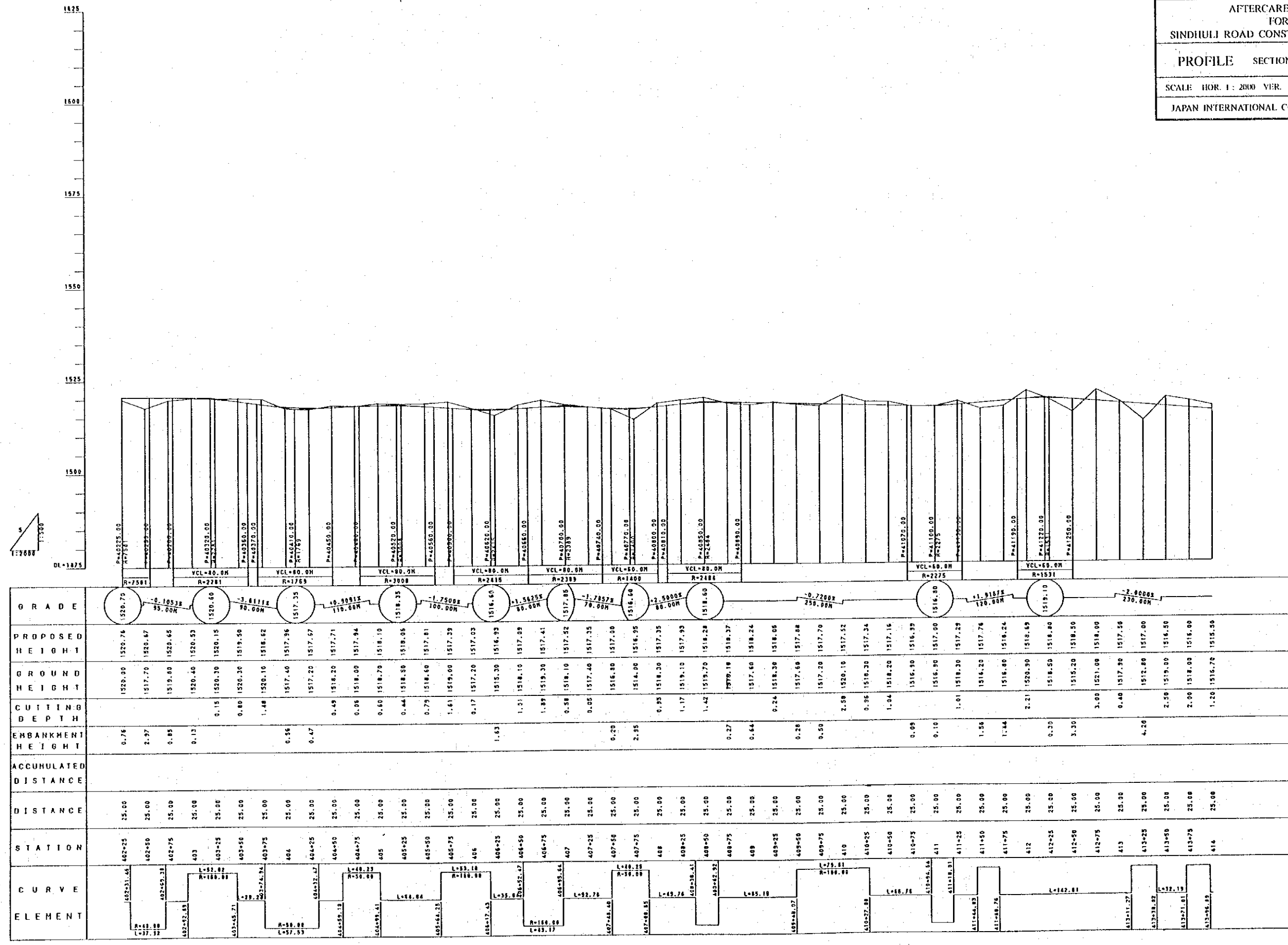

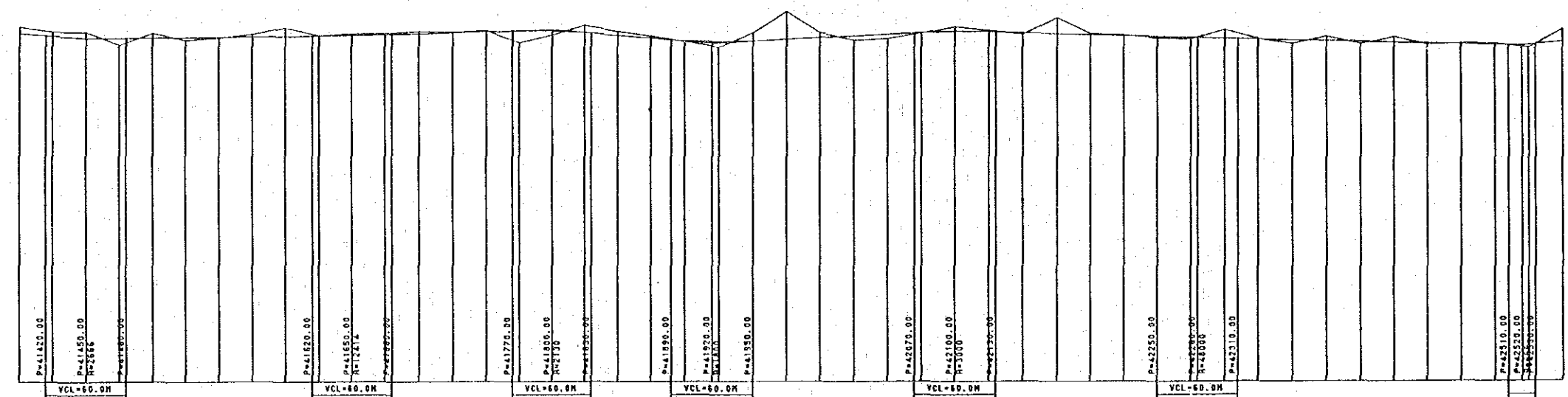
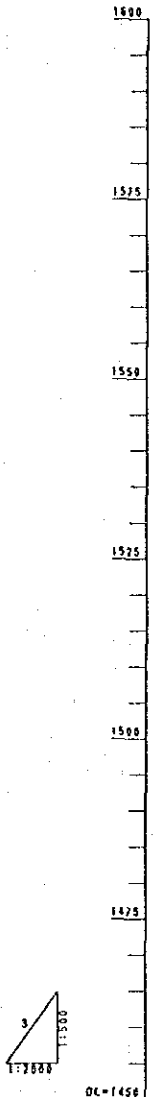

GRADE	PROPOSED HEIGHT	GROUND HEIGHT	CUTTING DEPTH	EMBANKMENT HEIGHT	ACCUMULATED DISTANCE	DISTANCE	STATION	CURVE ELEMENT
-2.2000% 230.00M	1513.30	1516.70	1.20	1.26		25.00	414	L=60.00 R=160.00
+0.2500% 200.00M	1515.00	1515.00	0.00	0.43		25.00	414+25	L=30.00 R=100.00
1514.50	1514.87	1514.87	1.03	0.15		25.00	414+50	L=123.00
1514.56	1514.56	1513.30	1.26	0.49		25.00	414+75	L=64.71 R=160.00
1514.63	1514.63	1514.50	0.07	0.15		25.00	415	L=30.00 R=100.00
1514.63	1514.63	1514.20	0.43	0.43		25.00	415+25	L=64.71 R=160.00
1514.75	1514.75	1514.60	0.15	0.15		25.00	415+50	L=123.00
1514.91	1514.91	1515.30	0.49	0.49		25.00	415+75	L=64.71 R=160.00
1514.88	1514.88	1516.50	1.62	0.43		25.00	416	L=30.00 R=100.00
1514.94	1514.94	1515.00	0.06	0.43		25.00	416+25	L=64.71 R=160.00
1515.04	1515.04	1515.30	0.26	0.43		25.00	416+50	L=123.00
1515.19	1515.19	1515.40	0.22	0.43		25.00	416+75	L=64.71 R=160.00
1515.37	1515.37	1515.80	0.43	0.43		25.00	417	L=30.00 R=100.00
1515.73	1515.73	1515.90	0.17	0.43		25.00	417+25	L=64.71 R=160.00
1515.91	1515.91	1513.70	2.21	0.75		25.00	417+50	L=30.00 R=100.00
1516.10	1516.10	1515.10	1.00	0.75		25.00	418	L=77.00
1515.57	1515.57	1516.90	1.33	0.75		25.00	418+25	L=30.00 R=100.00
1515.06	1515.06	1515.80	0.74	0.75		25.00	418+50	L=64.71 R=160.00
1514.34	1514.34	1514.50	0.16	0.75		25.00	418+75	L=64.71 R=160.00
1514.05	1514.05	1513.30	0.75	0.75		25.00	419	L=64.71 R=160.00
1513.83	1513.83	1512.80	1.03	1.03		25.00	419+25	L=30.00 R=100.00
1513.98	1513.98	1515.50	1.52	1.03		25.00	419+50	L=64.71 R=160.00
1514.29	1514.29	1519.50	5.21	1.03		25.00	419+75	L=30.00 R=100.00
1514.60	1514.60	1515.50	0.90	1.03		25.00	420	L=266.37
1515.48	1515.48	1514.10	1.38	1.03		25.00	420+25	L=30.00 R=100.00
1515.23	1515.23	1514.40	0.83	1.03		25.00	420+50	L=64.71 R=160.00
1515.54	1515.54	1515.40	0.14	1.03		25.00	420+75	L=64.71 R=160.00
1515.70	1515.70	1516.60	0.90	1.03		25.00	421	L=30.00 R=100.00
1515.66	1515.66	1515.90	0.24	1.03		25.00	421+25	L=64.71 R=160.00
1515.48	1515.48	1515.20	0.28	1.03		25.00	421+50	L=30.00 R=100.00
1515.39	1515.39	1518.30	3.01	1.03		25.00	421+75	L=64.71 R=160.00
1515.10	1515.10	1515.30	0.20	1.03		25.00	422	L=30.00 R=100.00
1514.91	1514.91	1515.00	0.09	1.03		25.00	422+25	L=64.71 R=160.00
1514.73	1514.73	1514.40	0.33	1.03		25.00	422+50	L=30.00 R=100.00
1514.55	1514.55	1514.30	0.25	1.03		25.00	422+75	L=64.71 R=160.00
1514.38	1514.38	1516.00	1.62	1.03		25.00	423	L=30.00 R=100.00
1514.22	1514.22	1514.30	0.08	1.03		25.00	423+25	L=64.71 R=160.00
1514.05	1514.05	1513.40	0.65	1.03		25.00	423+50	L=30.00 R=100.00
1513.75	1513.75	1516.70	3.01	1.03		25.00	423+75	L=64.71 R=160.00
1513.59	1513.59	1513.40	0.19	1.03		25.00	424	L=30.00 R=100.00
1513.44	1513.44	1513.20	0.24	1.03		25.00	424+25	L=64.71 R=160.00
1513.28	1513.28	1513.40	0.12	1.03		25.00	424+50	L=30.00 R=100.00
1513.13	1513.13	1513.40	0.27	1.03		25.00	424+75	L=64.71 R=160.00
1513.14	1513.14	1512.80	0.34	1.03		25.00	425	L=30.00 R=100.00
1513.71	1513.71	1516.00	2.29	1.03		25.00	425+25	L=64.71 R=160.00

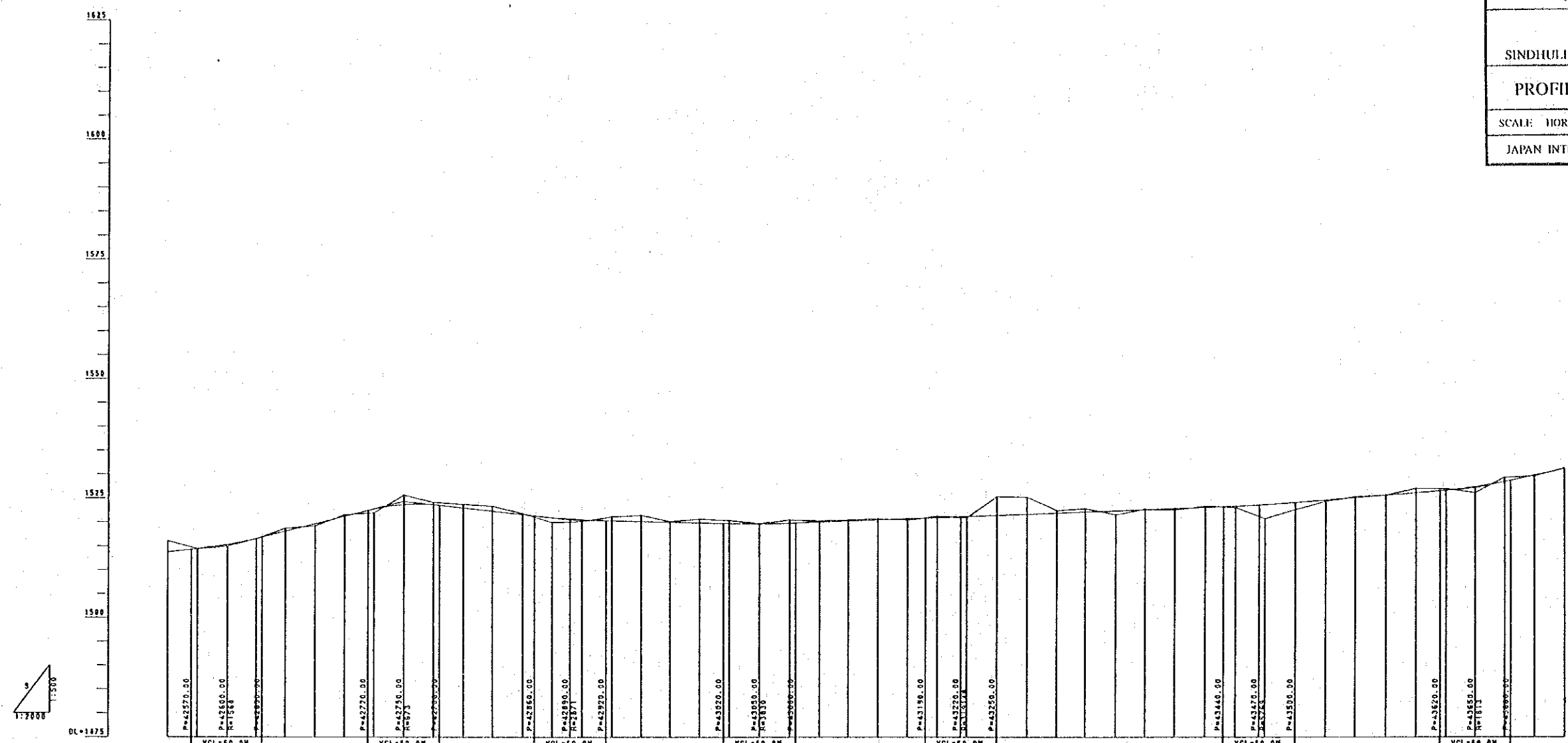

GRADE	PROPOSED HEIGHT	GROUND HEIGHT	CUTTING DEPTH	EMBANKMENT HEIGHT	ACCUMULATED DISTANCE	DISTANCE	STATION	CURVE ELEMENT
1513.71	1513.71	1516.00	2.29			25.00	425+50	
1514.32	1514.32	1514.40	0.08			25.00	426+25	
1515.19	1515.19	1515.20	0.01			25.00	426+50	
1516.46	1516.46	1516.40	0.06			25.00	426+75	
1518.00	1518.00	1518.10	0.10			25.00	427+00	
1521.16	1521.16	1521.40	0.24			25.00	427+25	
1522.63	1522.63	1521.00	1.63			25.00	427+50	
1523.33	1523.33	1523.50	0.17			25.00	427+75	
1523.50	1523.50	1524.00	0.50			25.00	428+00	
1522.84	1522.84	1523.60	0.76			25.00	428+25	
1522.16	1522.16	1523.20	1.04			25.00	428+50	
1521.45	1521.45	1521.70	0.25			25.00	428+75	
1520.05	1520.05	1519.00	1.05			25.00	429+00	
1520.41	1520.41	1520.00	0.41			25.00	429+25	
1520.18	1520.18	1520.00	0.18			25.00	429+50	
1520.03	1520.03	1521.30	1.27			25.00	429+75	
1519.87	1519.87	1520.00	0.13			25.00	430+00	
1519.71	1519.71	1520.50	0.79			25.00	430+25	
1519.56	1519.56	1520.20	0.64			25.00	430+50	
1519.40	1519.40	1519.50	0.10			25.00	430+75	
1519.44	1519.44	1520.30	0.86			25.00	431+00	
1520.11	1520.11	1520.30	0.19			25.00	431+25	
1520.34	1520.34	1520.50	0.16			25.00	431+50	
1520.58	1520.58	1520.30	0.28			25.00	431+75	
1520.81	1520.81	1521.10	0.29			25.00	432+00	
1521.05	1521.05	1520.80	0.25			25.00	432+25	
1521.29	1521.29	1523.20	1.91			25.00	432+50	
1521.53	1521.53	1523.10	1.57			25.00	432+75	
1521.77	1521.77	1522.30	0.53			25.00	433+00	
1522.01	1522.01	1522.70	0.69			25.00	433+25	
1522.25	1522.25	1521.40	0.85			25.00	433+50	
1522.49	1522.49	1522.60	0.11			25.00	433+75	
1522.73	1522.73	1522.40	0.33			25.00	434+00	
1522.97	1522.97	1523.20	0.23			25.00	434+25	
1523.22	1523.22	1522.90	0.32			25.00	434+50	
1523.55	1523.55	1520.60	2.95			25.00	434+75	
1524.00	1524.00	1522.50	1.50			25.00	435+00	
1524.50	1524.50	1524.20	0.30			25.00	435+25	
1525.00	1525.00	1525.20	0.20			25.00	435+50	
1525.56	1525.56	1525.50	0.06			25.00	435+75	
1526.00	1526.00	1526.90	0.90			25.00	436+00	
1526.51	1526.51	1526.80	0.29			25.00	436+25	
1527.05	1527.05	1526.00	1.05			25.00	436+50	
1528.34	1528.34	1529.20	0.86			25.00	436+75	
1529.85	1529.85	1529.50	0.35			25.00	437+00	
1530.98	1530.98	1531.10	0.12			25.00	437+25	

HIS MAJESTY'S GOVERNMENT OF NEPAL
 MINISTRY OF WORKS AND TRANSPORT
 DEPARTMENT OF ROADS
 AFTERCARE STUDY
 FOR
 SINDHULI ROAD CONSTRUCTION PROJECT
 PROFILE SECTION 11-3
 SHEET NO. B-134
 SCALE HOR. 1:2000 VER. 1:500
 DATE
 JAPAN INTERNATIONAL COOPERATION AGENCY

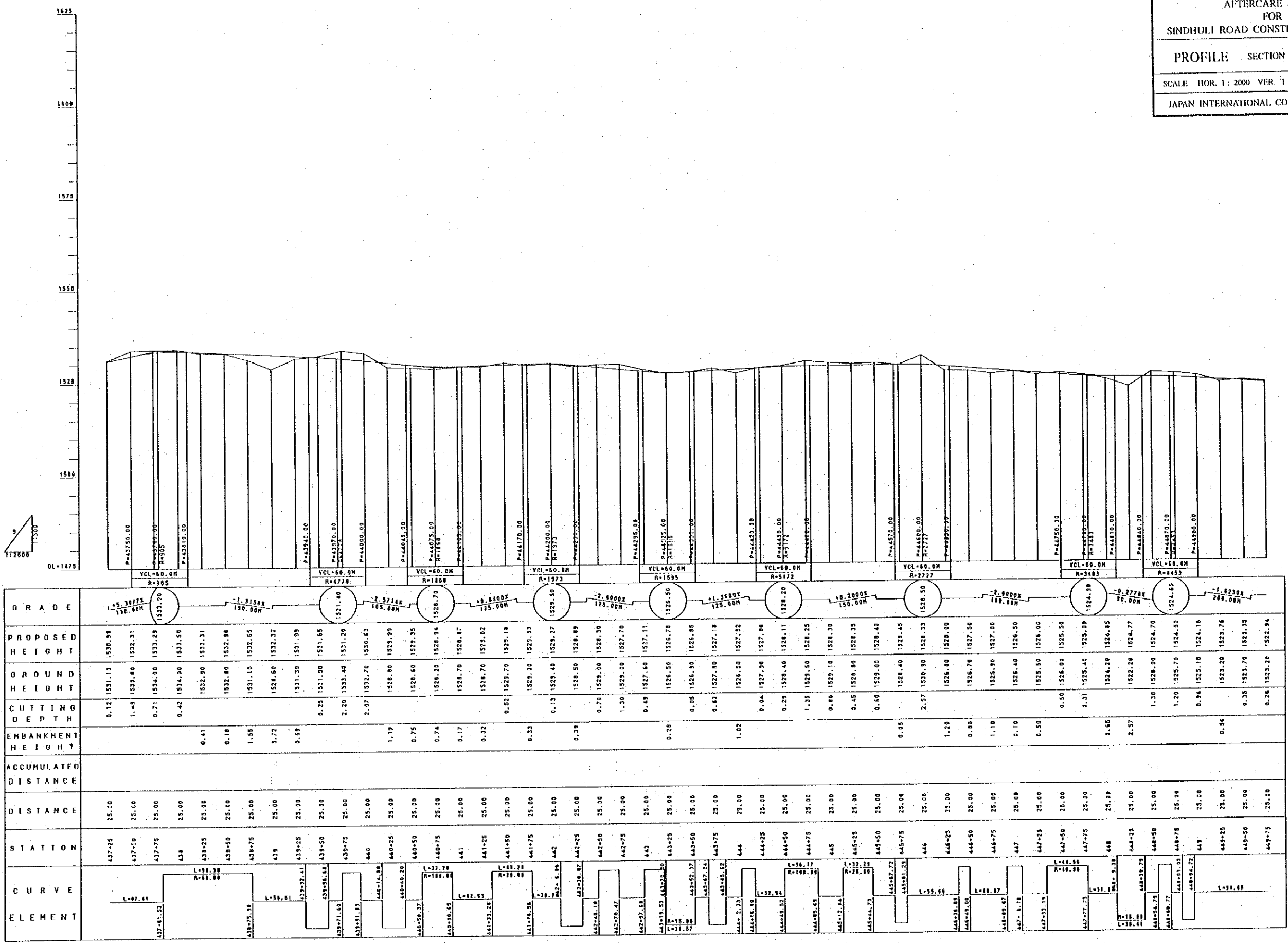

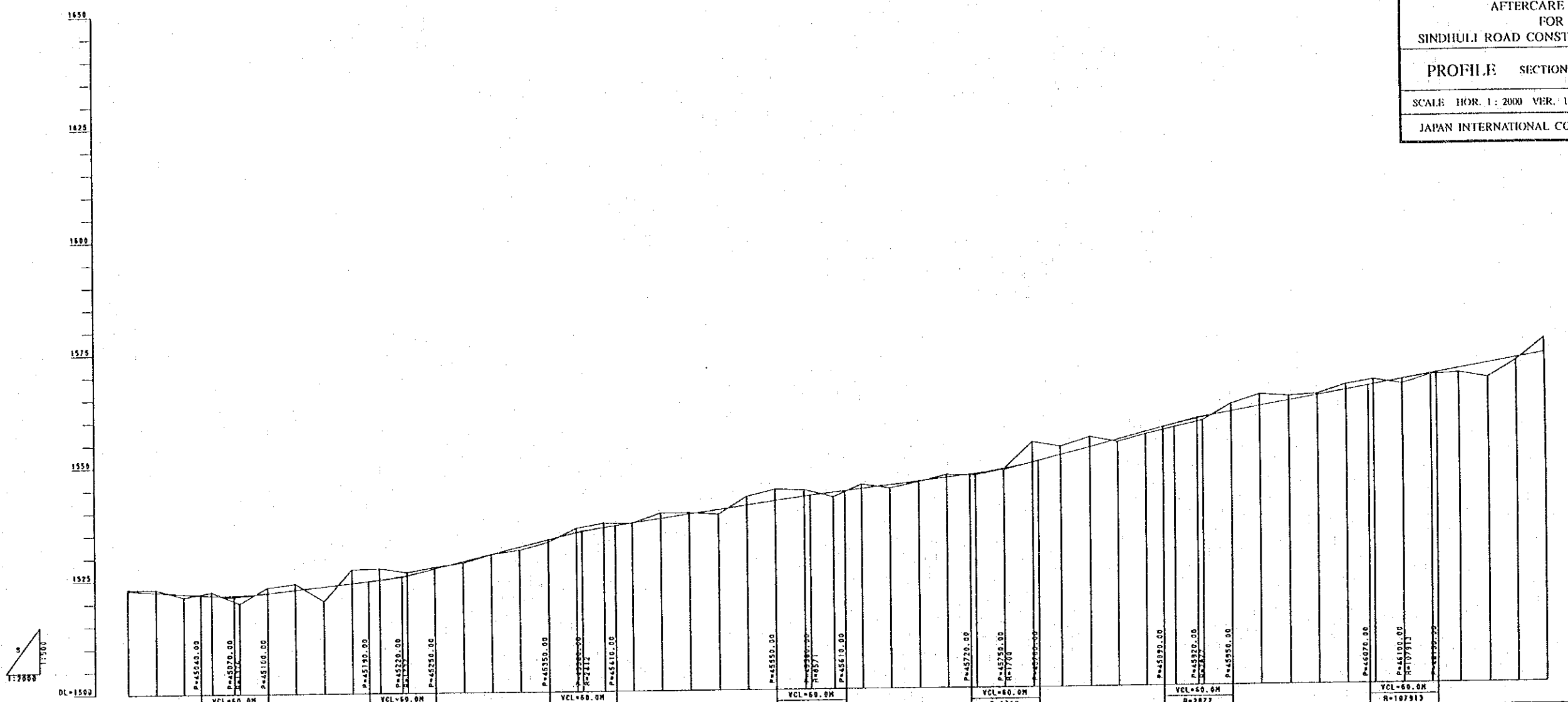

GRADE	PROPOSED HEIGHT	GROUND HEIGHT	CUTTING DEPTH	EMBANKMENT HEIGHT	ACCUMULATED DISTANCE	DISTANCE	STATION	CURVE ELEMENT
-1.6250% 200.00M	1522.94	1523.20	0.26	0.26	0.00	25.00	448+75	448+66.37
1.21.40 R=1376	1522.54	1522.10	0.56	0.56	0.56	25.00	450+00	450+00.00
12.7333% 150.00M	1522.22	1522.40	0.73	0.73	1.29	25.00	452+25	452+25.00
1.10 R=1737	1522.90	1524.20	1.30	1.30	2.59	25.00	454+50	454+50.00
16.1875% 160.00M	1527.36	1527.70	0.34	0.34	2.93	25.00	457+00	457+00.00
1.04 R=2412	1528.30	1528.60	0.30	0.30	3.23	25.00	459+25	459+25.00
3.7000% 200.00M	1537.99	1539.45	1.46	1.46	4.69	25.00	461+50	461+50.00
1.42 R=8571	1542.58	1544.10	1.52	1.52	6.21	25.00	463+75	463+75.00
3.0000% 170.00M	1546.40	1548.10	1.62	1.62	7.83	25.00	466+00	466+00.00
1.46 R=10781	1551.18	1553.00	1.82	1.82	9.65	25.00	468+25	468+25.00
4.6229% 170.00M	1556.06	1558.40	2.42	2.42	12.07	25.00	470+50	470+50.00
1.559.00 R=2877	1561.44	1564.00	2.56	2.56	14.63	25.00	472+75	472+75.00
4.6229% 170.00M	1562.56	1564.00	1.44	1.44	16.07	25.00	475+00	475+00.00
1.559.00 R=2877	1563.67	1566.00	2.33	2.33	18.40	25.00	477+25	477+25.00
4.6229% 170.00M	1564.78	1567.00	2.22	2.22	20.62	25.00	479+50	479+50.00
1.559.00 R=2877	1565.89	1567.00	1.11	1.11	21.73	25.00	481+75	481+75.00
4.6229% 170.00M	1567.00	1568.00	1.00	1.00	22.73	25.00	484+00	484+00.00
1.559.00 R=2877	1568.13	1569.00	0.87	0.87	23.60	25.00	486+25	486+25.00
4.6229% 170.00M	1569.25	1570.00	0.75	0.75	24.35	25.00	488+50	488+50.00
1.559.00 R=2877	1570.38	1571.00	0.62	0.62	25.00	25.00	490+75	490+75.00
4.6229% 170.00M	1571.50	1572.00	0.50	0.50	25.50	25.00	493+00	493+00.00

HIS MAJESTY'S GOVERNMENT OF NEPAL.
MINISTRY OF WORKS AND TRANSPORT
DEPARTMENT OF ROADS

AFTERCARE STUDY
FOR
SINDHULI ROAD CONSTRUCTION PROJECT

PROFILE SECTION II-3 SHEET NO. B-136

SCALE HOR. 1:2000 VER. 1:500 DATE

JAPAN INTERNATIONAL COOPERATION AGENCY

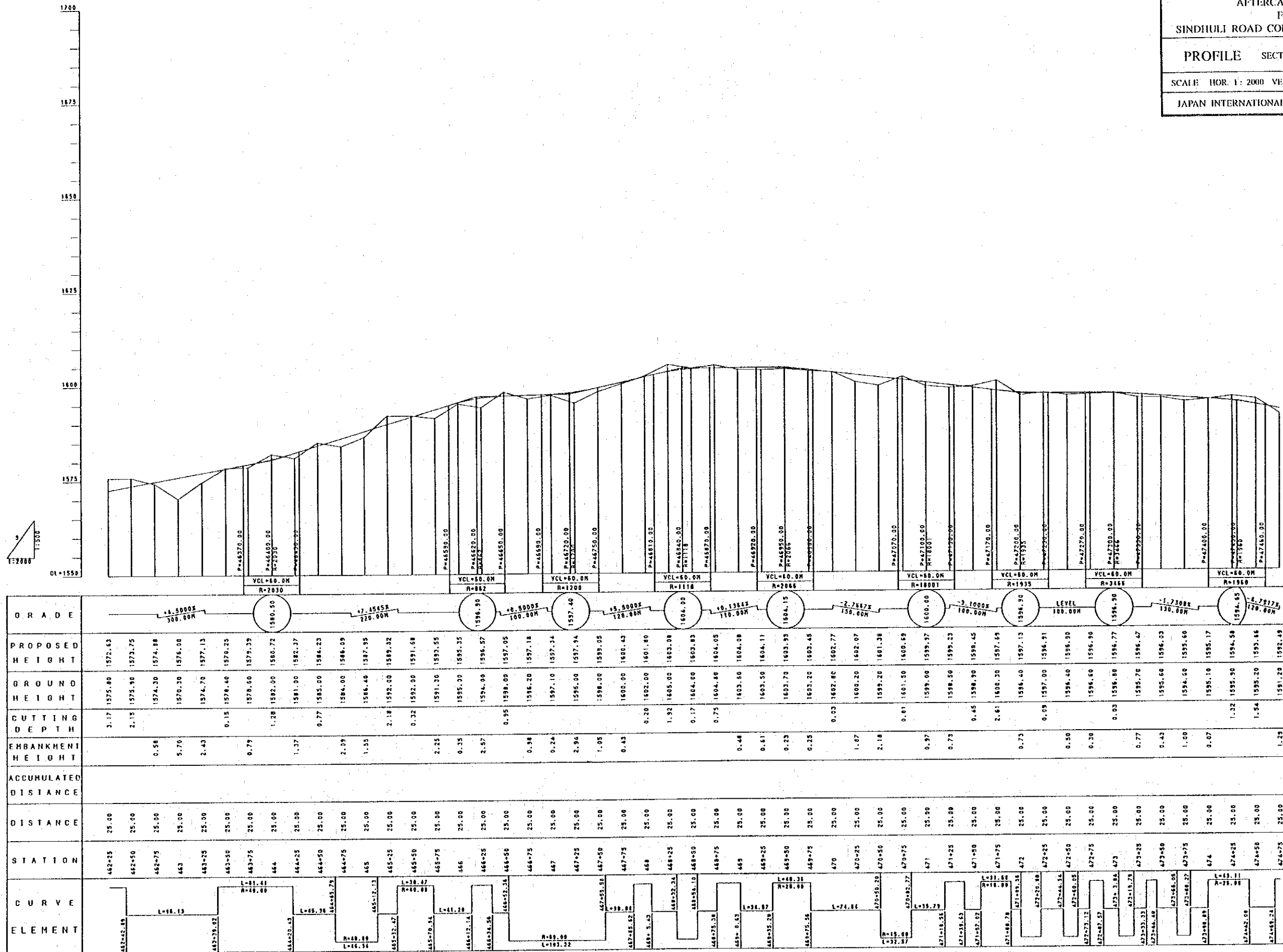

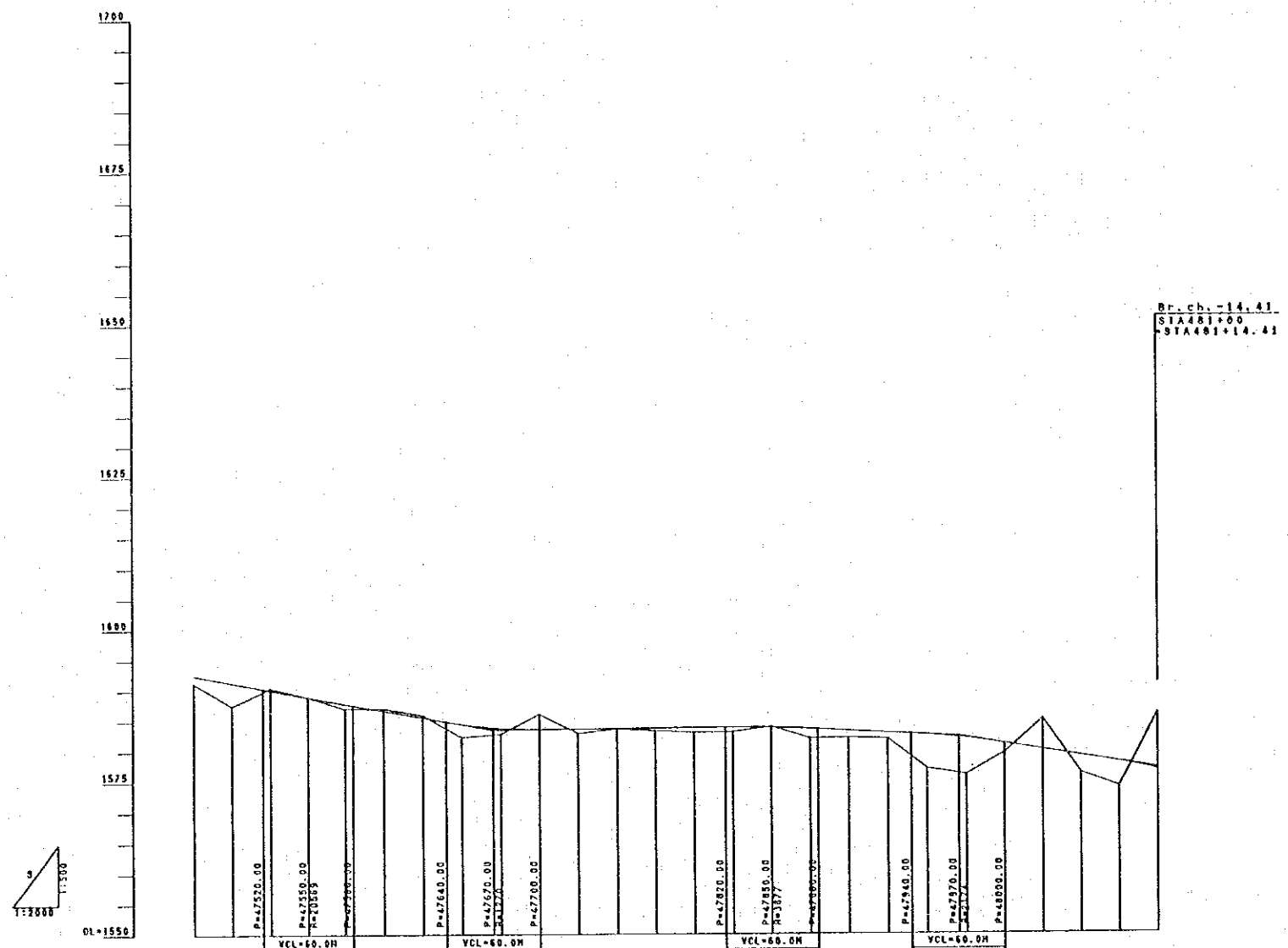

GRADE	PROPOSED HEIGHT	GROUND HEIGHT	CUTTING DEPTH	EMBANKMENT HEIGHT	ACCUMULATED DISTANCE	DISTANCE	STATION	CURVE ELEMENT
-4.7517%	1592.49	1591.20	1.29			25.00	474+75	L=71.00
	1591.30	1587.50	3.80			25.00	475+00	
	1590.10	1590.40	0.30			25.00	475+25	
	1586.92	1586.50	0.42			25.00	475+50	
	1587.78	1587.00	0.78			25.00	475+75	
	1586.45	1587.00	0.55			25.00	476+00	
	1585.33	1585.90	0.57			25.00	476+25	
	1584.44	1582.30	2.14			25.00	476+50	
	1583.76	1582.80	0.96			25.00	476+75	
	1583.37	1586.00	2.63			25.00	477+00	
	1583.62	1582.90	0.72			25.00	477+25	
	1583.60	1583.60	0.00			25.00	477+50	
	1583.73	1583.30	0.43			25.00	477+75	
	1583.79	1583.00	0.79			25.00	478+00	
	1583.84	1583.10	0.74			25.00	478+25	
	1583.90	1583.90	0.00			25.00	478+50	
	1583.57	1582.00	1.57			25.00	478+75	
	1583.24	1582.10	1.14			25.00	479+00	
	1582.81	1581.90	0.91			25.00	479+25	
	1582.56	1577.00	5.56			25.00	479+50	
	1581.97	1576.00	5.97			25.00	479+75	
	1581.08	1579.50	1.58			25.00	480+00	
	1580.06	1585.00	4.94			25.00	480+25	
	1579.04	1576.20	2.84			25.00	480+50	
	1578.01	1574.00	4.01			25.00	480+75	
	1576.68	1566.00	9.68			25.00	481+00	

R.P. ch. -14.41
 STA 481+00
 STA 481+14.41

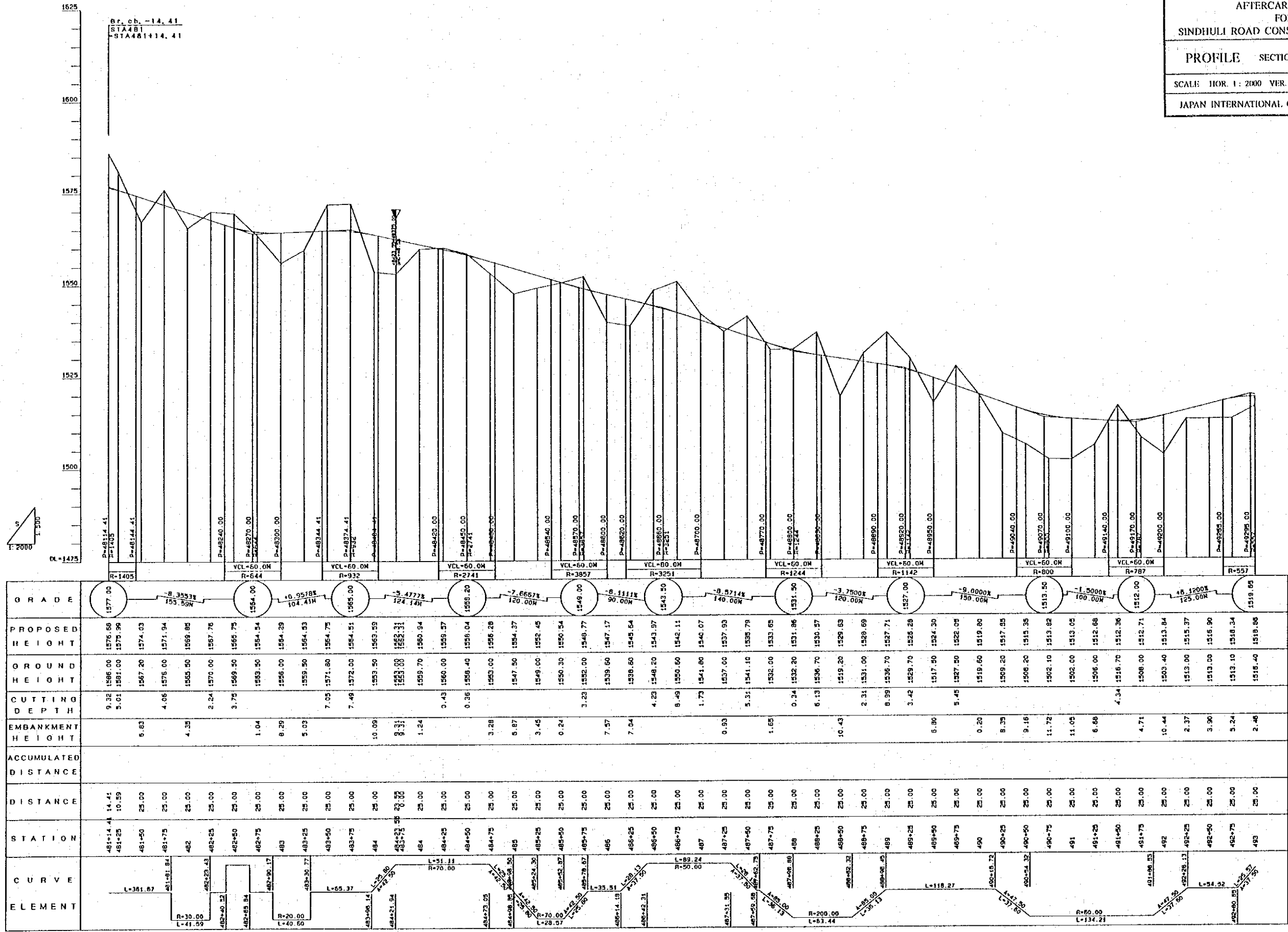

HIS MAJESTY'S GOVERNMENT OF NEPAL
 MINISTRY OF WORKS AND TRANSPORT
 DEPARTMENT OF ROADS

AFTERCARE STUDY
 FOR
 SINDHULI ROAD CONSTRUCTION PROJECT

PROFILE SECTION II-3

SCALE HOR. 1:2000 VER. 1:500

JAPAN INTERNATIONAL COOPERATION AGENCY

Section II-3
 Length of Section
 L=50248.55

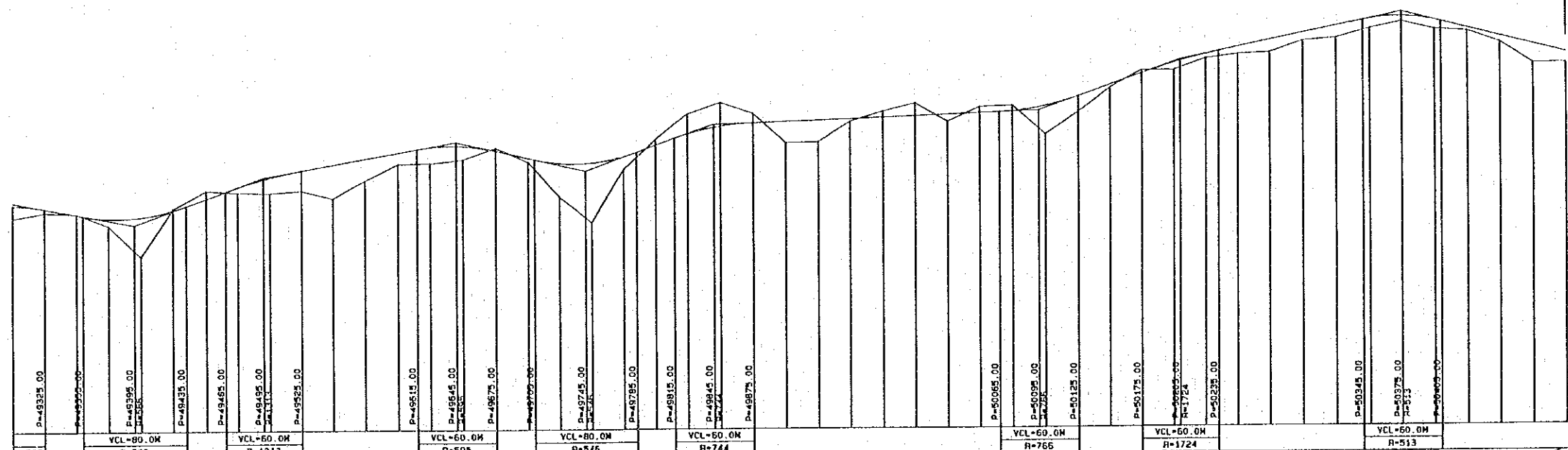
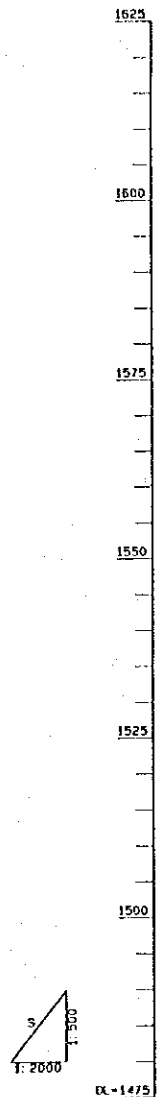

GRADE	PROPOSED HEIGHT	GROUND HEIGHT	CUTTING DEPTH	EMBANKMENT HEIGHT	ACCUMULATED DISTANCE	DISTANCE	STATION	CURVE ELEMENT
-4.6500% 100.00M	1518.85	1516.40	2.46			25.00	493	L=6.22 R=35.00
	1518.26	1517.50	0.76			25.00	493+25	L=35.00 R=35.00
	1517.09	1517.20	0.11			25.00	493+50	L=35.00 R=35.00
	1516.27	1514.90	1.37			25.00	493+75	L=35.00 R=35.00
	1516.50	1508.90	7.70			25.00	494	L=35.00 R=35.00
	1517.75	1518.00	0.21			25.00	494+25	L=35.00 R=35.00
+9.0000% 100.00M	1519.95	1521.50	1.55			25.00	494+50	L=35.00 R=35.00
	1522.16	1521.10	1.06			25.00	494+75	L=35.00 R=35.00
	1522.98	1521.00	2.98			25.00	495	L=35.00 R=35.00
	1523.33	1521.40	3.93			25.00	495+25	L=35.00 R=35.00
	1525.44	1519.90	6.54			25.00	495+50	L=35.00 R=35.00
	1527.85	1523.30	4.25			25.00	495+75	L=35.00 R=35.00
	1528.65	1526.50	2.15			25.00	496	L=35.00 R=35.00
	1529.68	1526.60	3.08			25.00	496+25	L=35.00 R=35.00
	1529.84	1527.30	2.54			25.00	496+50	L=35.00 R=35.00
	1528.96	1529.50	0.54			25.00	496+75	L=35.00 R=35.00
	1527.54	1526.90	0.74			25.00	497	L=35.00 R=35.00
	1526.50	1520.00	6.50			25.00	497+25	L=35.00 R=35.00
	1526.57	1515.00	11.57			25.00	497+50	L=35.00 R=35.00
	1527.79	1525.30	2.49			25.00	497+75	L=35.00 R=35.00
	1529.95	1531.10	1.15			25.00	498	L=35.00 R=35.00
	1532.13	1536.00	3.87			25.00	498+25	L=35.00 R=35.00
	1533.63	1538.20	4.57			25.00	498+50	L=35.00 R=35.00
	1534.28	1536.10	1.82			25.00	498+75	L=35.00 R=35.00
	1534.52	1530.40	4.12			25.00	499	L=35.00 R=35.00
	1534.75	1530.50	4.25			25.00	499+25	L=35.00 R=35.00
	1534.99	1534.50	0.49			25.00	499+50	L=35.00 R=35.00
	1535.45	1537.90	1.45			25.00	499+75	L=35.00 R=35.00
	1535.69	1534.30	1.39			25.00	500	L=35.00 R=35.00
	1535.93	1537.10	1.17			25.00	500+25	L=35.00 R=35.00
	1536.23	1537.30	1.07			25.00	500+50	L=35.00 R=35.00
	1537.20	1531.70	5.90			25.00	500+75	L=35.00 R=35.00
	1539.98	1536.00	2.98			25.00	501	L=35.00 R=35.00
	1541.17	1540.80	0.37			25.00	501+25	L=35.00 R=35.00
	1543.37	1544.00	0.63			25.00	501+50	L=35.00 R=35.00
	1545.58	1544.00	1.58			25.00	501+75	L=35.00 R=35.00
	1547.03	1546.20	0.83			25.00	502	L=35.00 R=35.00
	1548.38	1547.00	1.38			25.00	502+25	L=35.00 R=35.00
	1549.71	1547.30	2.41			25.00	502+50	L=35.00 R=35.00
	1551.03	1549.50	1.53			25.00	502+75	L=35.00 R=35.00
	1552.35	1550.00	2.35			25.00	503	L=35.00 R=35.00
	1553.66	1551.80	1.86			25.00	503+25	L=35.00 R=35.00
	1555.00	1553.10	1.90			25.00	503+50	L=35.00 R=35.00
	1556.35	1553.10	3.25			25.00	503+75	L=35.00 R=35.00
	1557.70	1551.60	6.10			25.00	504	L=35.00 R=35.00
	1559.05	1551.20	7.85			25.00	504+25	L=35.00 R=35.00
	1560.40	1549.00	1.40			25.00	504+50	L=35.00 R=35.00
	1561.75	1544.90	6.85			25.00	504+75	L=35.00 R=35.00
	1563.10	1543.00	1.10			25.00	505	L=35.00 R=35.00

STAB.05

C. STANDARD CROSS SECTION
ROADWAY

INITIAL STAGE

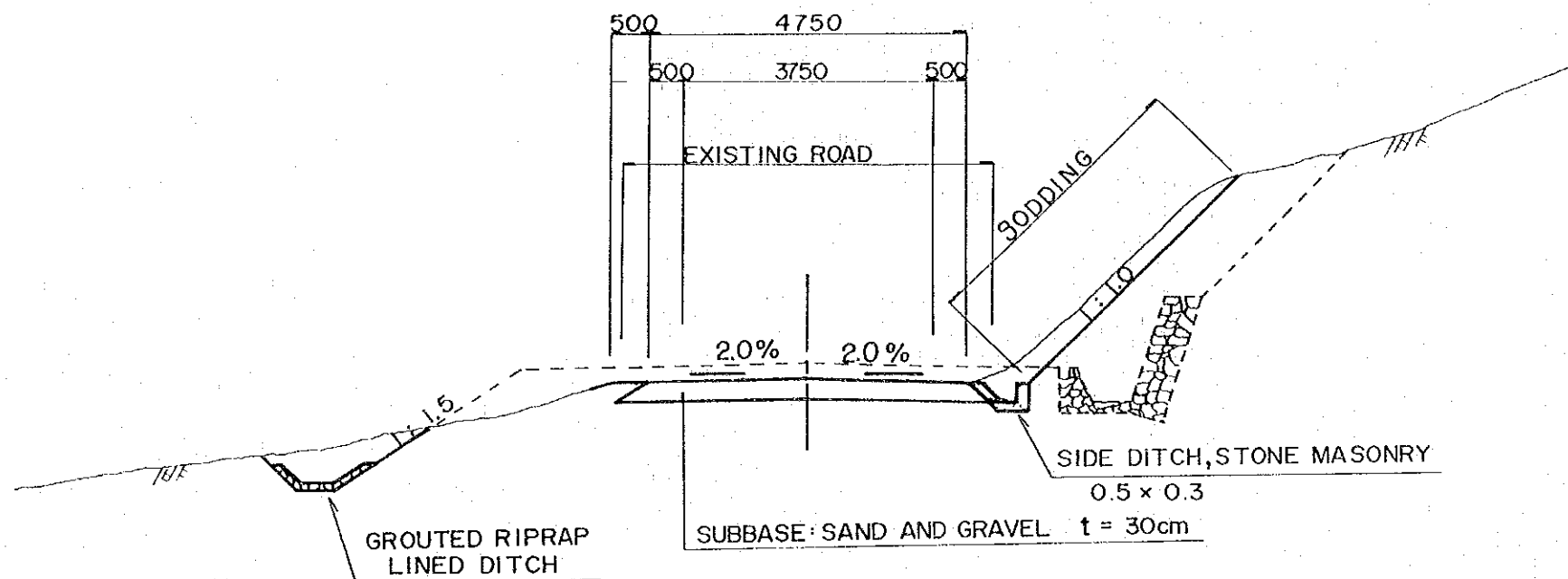

FINAL STAGE

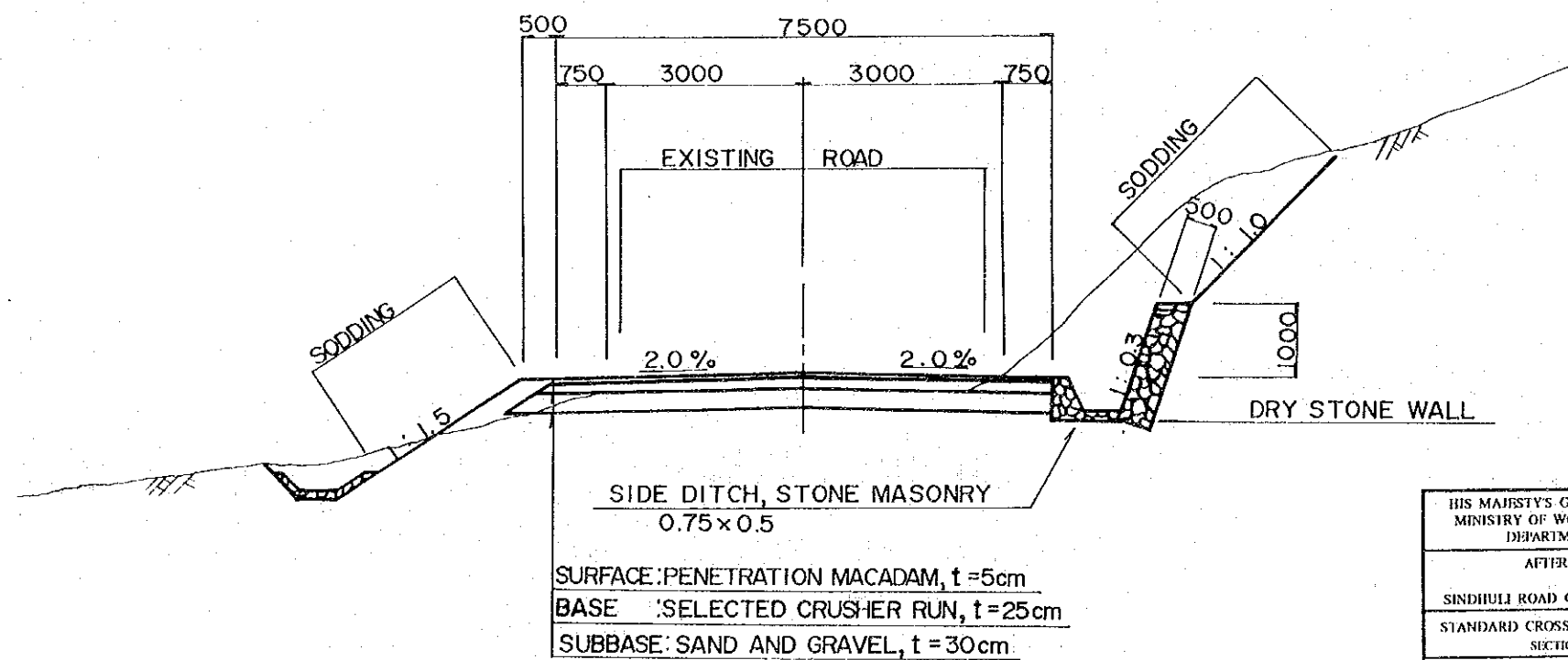

HIS MAJESTY'S GOVERNMENT OF NEPAL MINISTRY OF WORKS AND TRANSPORT DEPARTMENT OF ROADS	
AFTERCARE STUDY FOR SINDHULI ROAD CONSTRUCTION PROJECT	
STANDARD CROSS SECTION SECTION 1 (1/2)	SHEET NO. C - 1
SCALE 1:100	DATE
JAPAN INTERNATIONAL COOPERATION AGENCY	

INITIAL STAGE

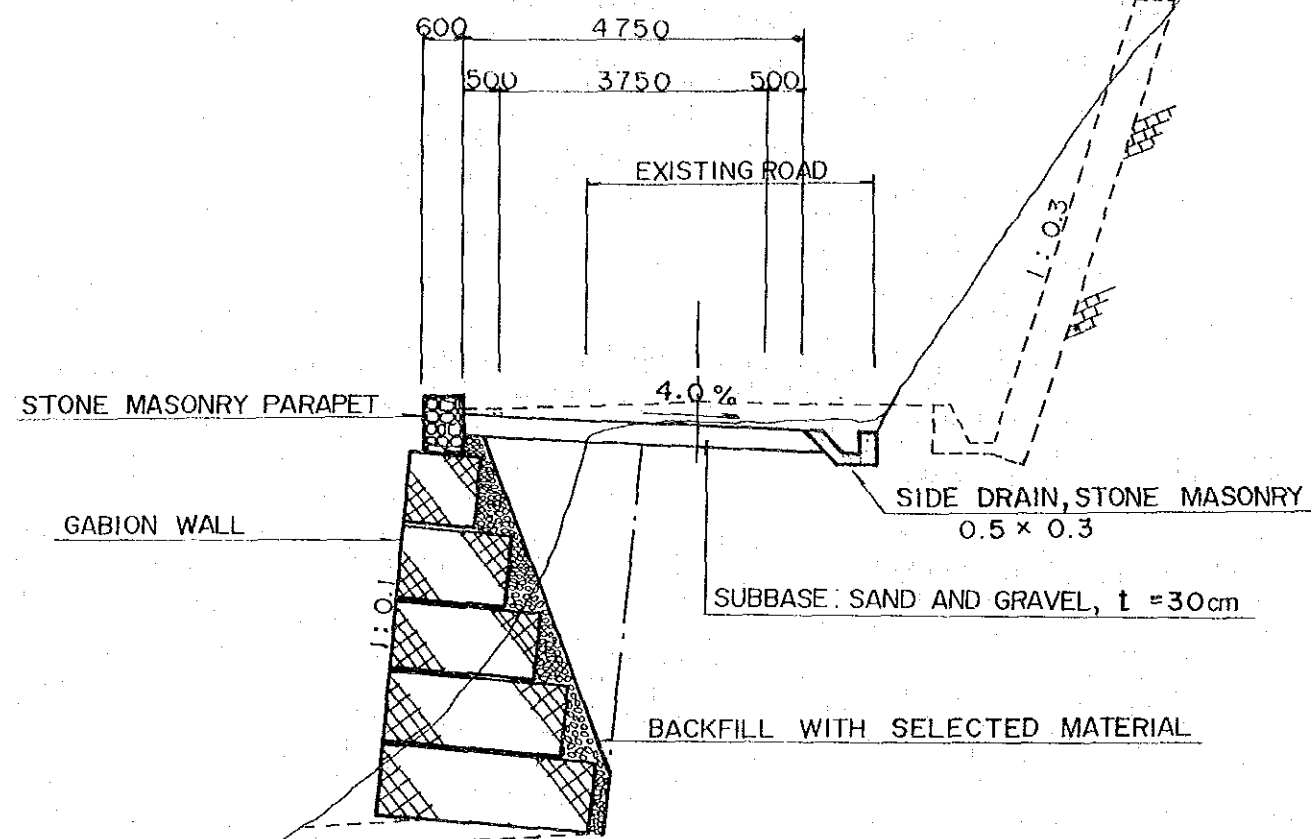

MOUNTAINOUS SECTION

FINAL STAGE

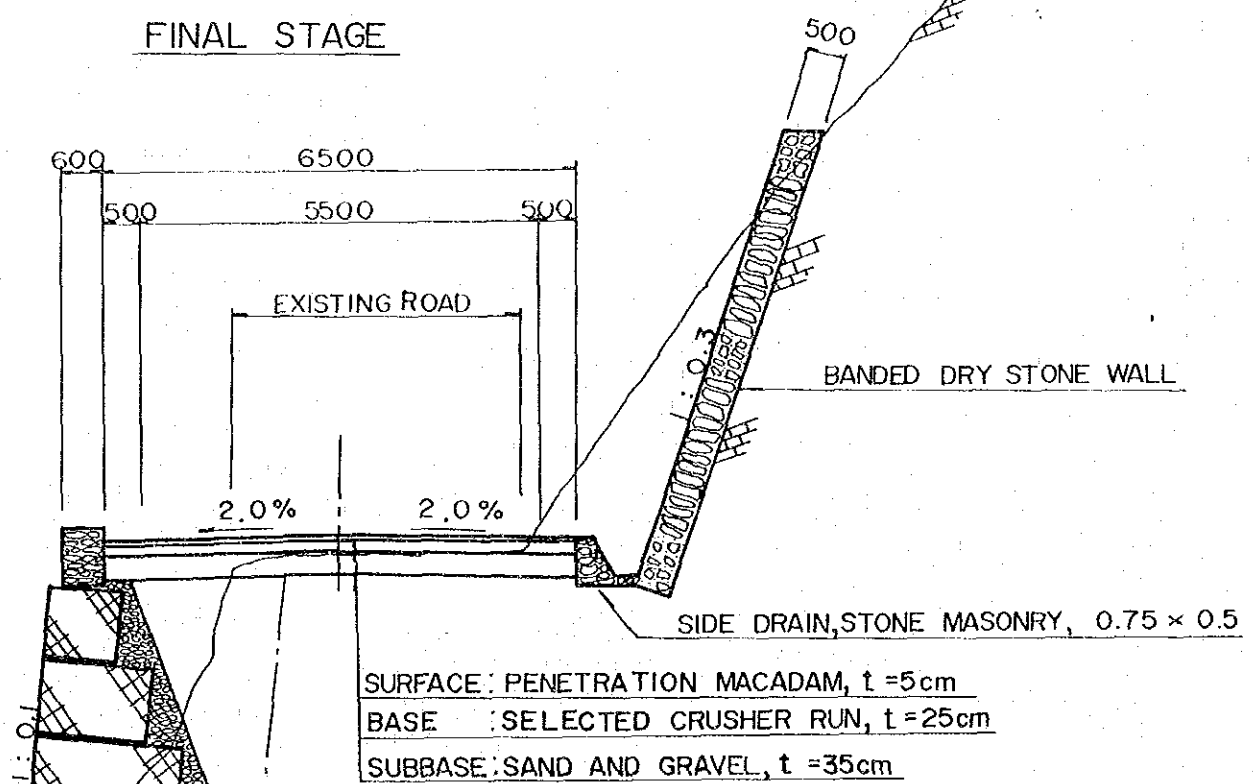

HIS MAJESTY'S GOVERNMENT OF NEPAL MINISTRY OF WORKS AND TRANSPORT DEPARTMENT OF ROADS	
AFTERCARE STUDY FOR SINDHUJ ROAD CONSTRUCTION PROJECT	
STANDARD CROSS SECTION SECTION 1 (2/2)	SHEET NO. C-2
SCALE: 1:100	DATE
JAPAN INTERNATIONAL COOPERATION AGENCY	

INITIAL STAGE

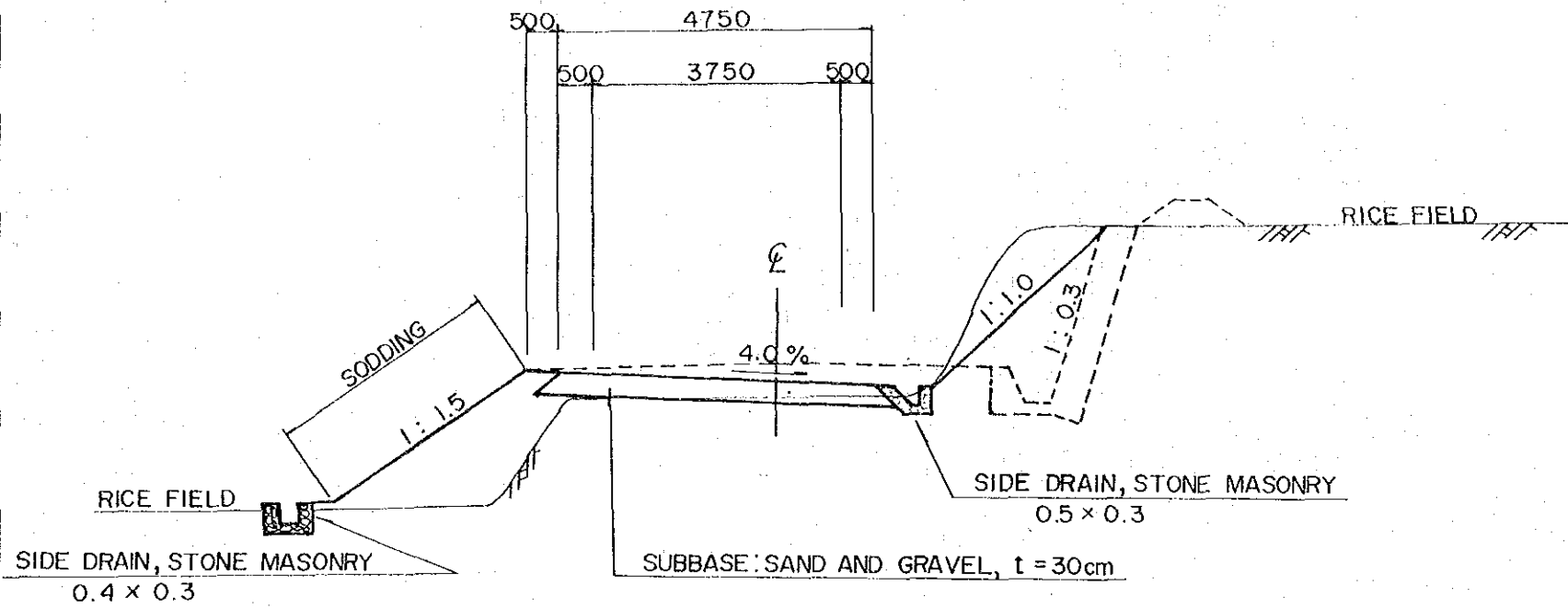

LEVEL AND ROLLING SECTION

FINAL STAGE

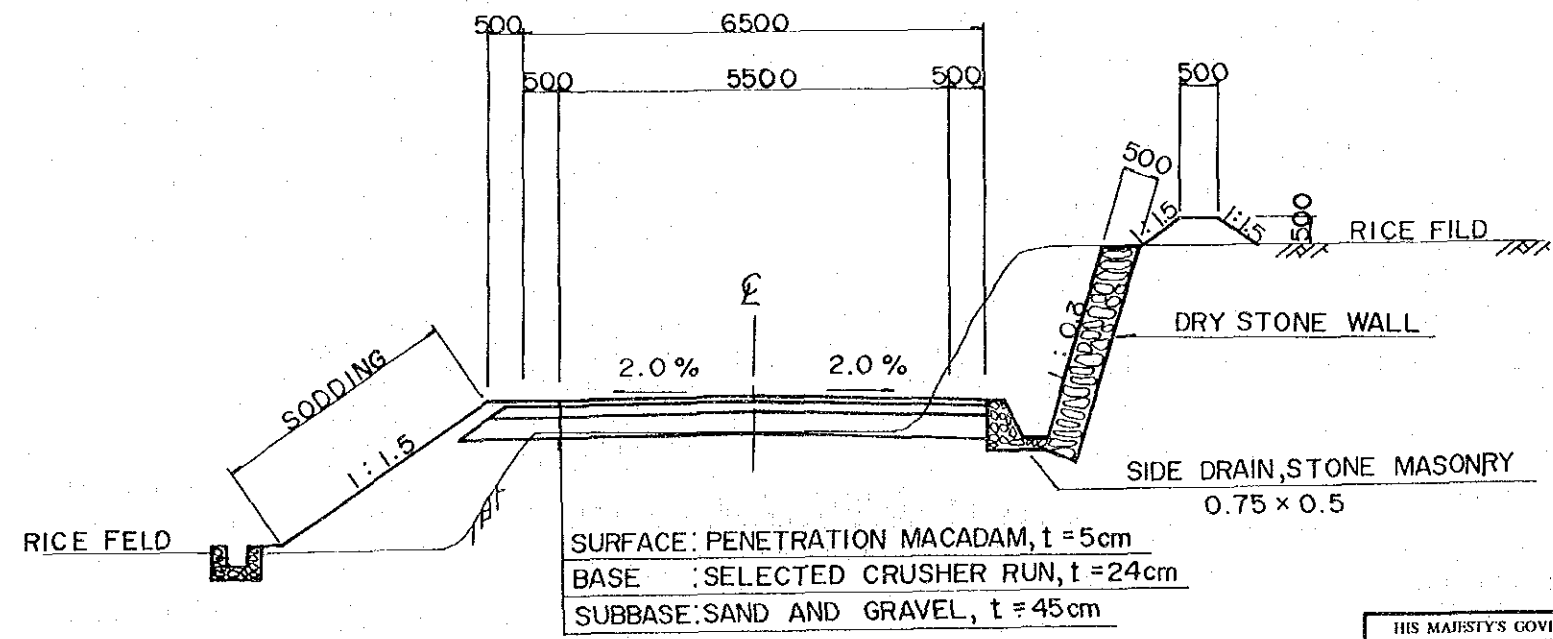

HIS MAJESTY'S GOVERNMENT OF NEPAL MINISTRY OF WORKS AND TRANSPORT DEPARTMENT OF ROADS	
AFTERCARE STUDY FOR SINDHULI ROAD CONSTRUCTION PROJECT	
STANDARD CROSS SECTION SECTION II (1/5)	SHEET NO C-3
SCALE: 1:100	DATE
JAPAN INTERNATIONAL COOPERATION AGENCY	

INITIAL STAGE

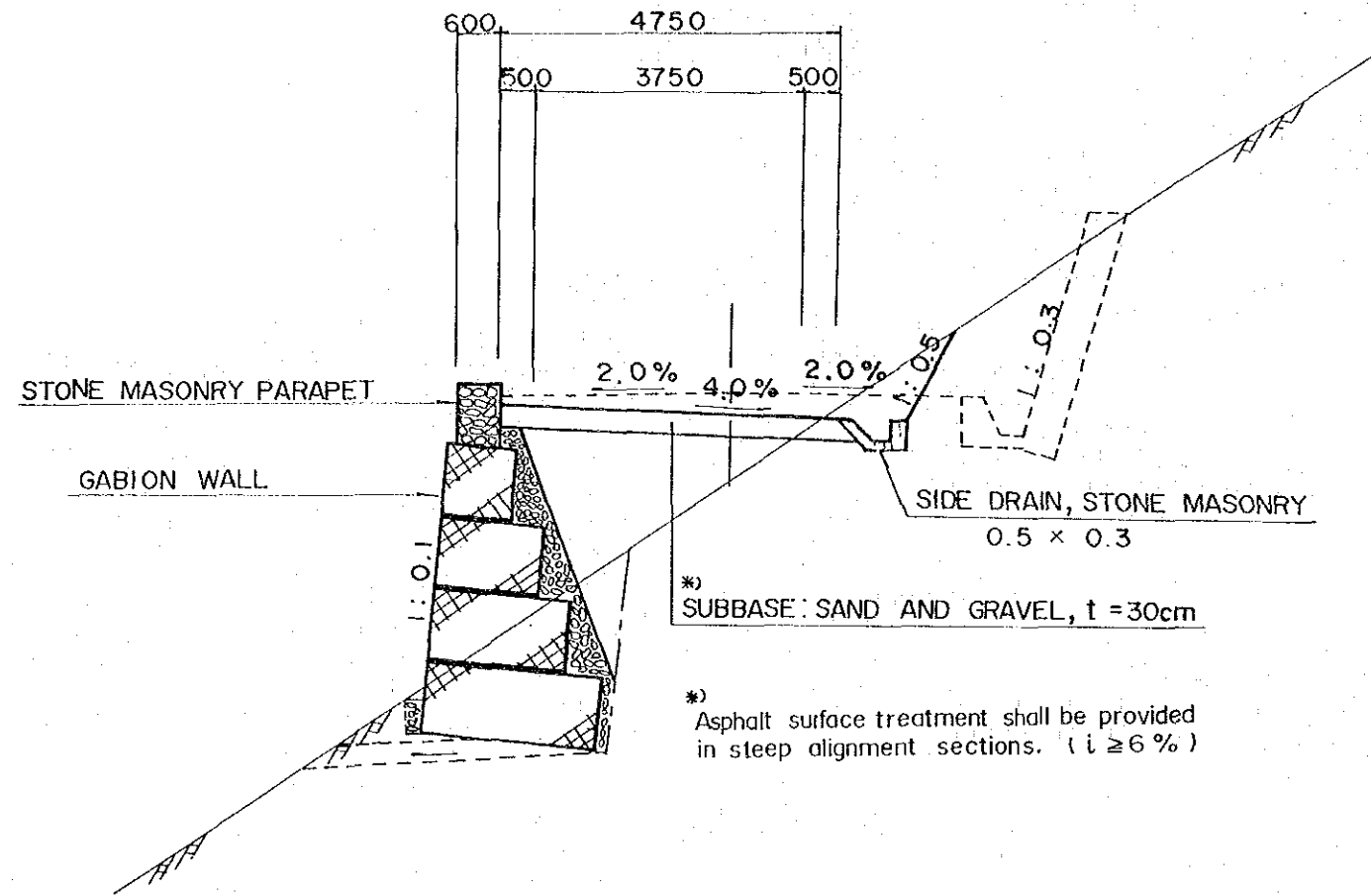

*) SUBBASE: SAND AND GRAVEL, t = 30cm

*) Asphalt surface treatment shall be provided in steep alignment sections. (i ≥ 6%)

MOUNTAINOUS SECTION

FINAL STAGE

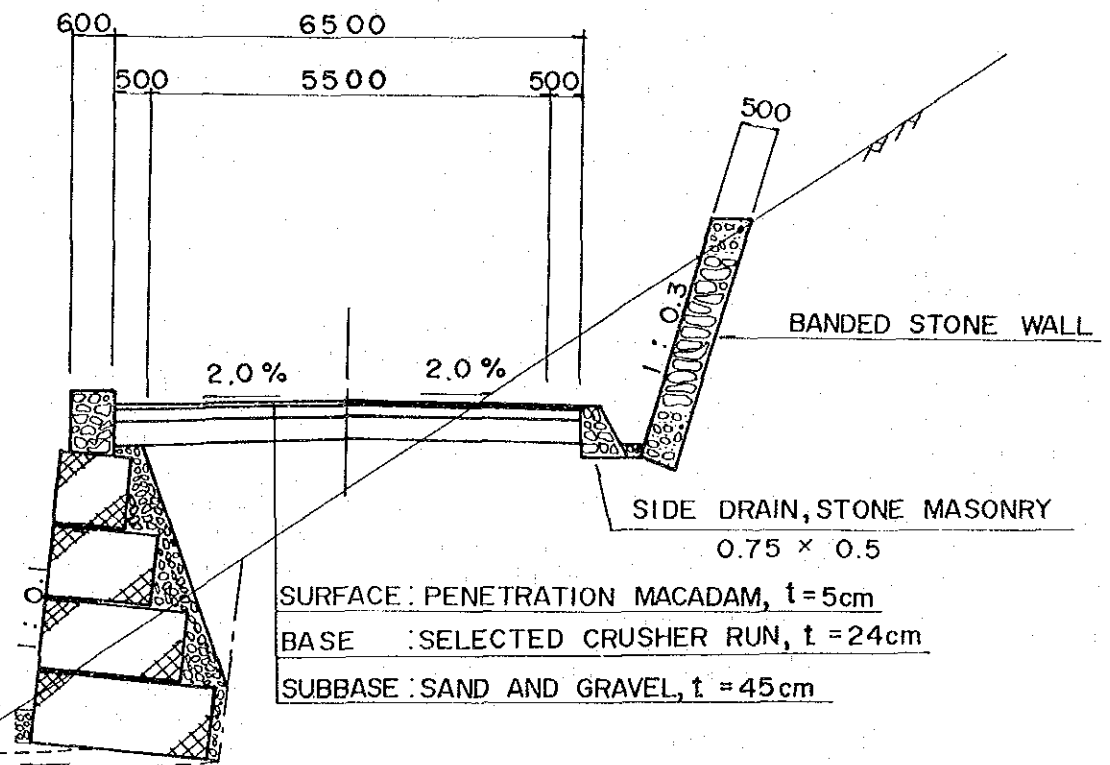

SURFACE: PENETRATION MACADAM, t = 5cm
 BASE: SELECTED CRUSHER RUN, t = 24cm
 SUBBASE: SAND AND GRAVEL, t = 45cm

HIS MAJESTY'S GOVERNMENT OF NEPAL MINISTRY OF WORKS AND TRANSPORT DEPARTMENT OF ROADS	
AFTERCARE STUDY FOR SINDHULI ROAD CONSTRUCTION PROJECT	
STANDARD CROSS SECTION SECTION II (2/5)	SHEET NO C-4
SCALE 1:100	DATE
JAPAN INTERNATIONAL COOPERATION AGENCY	

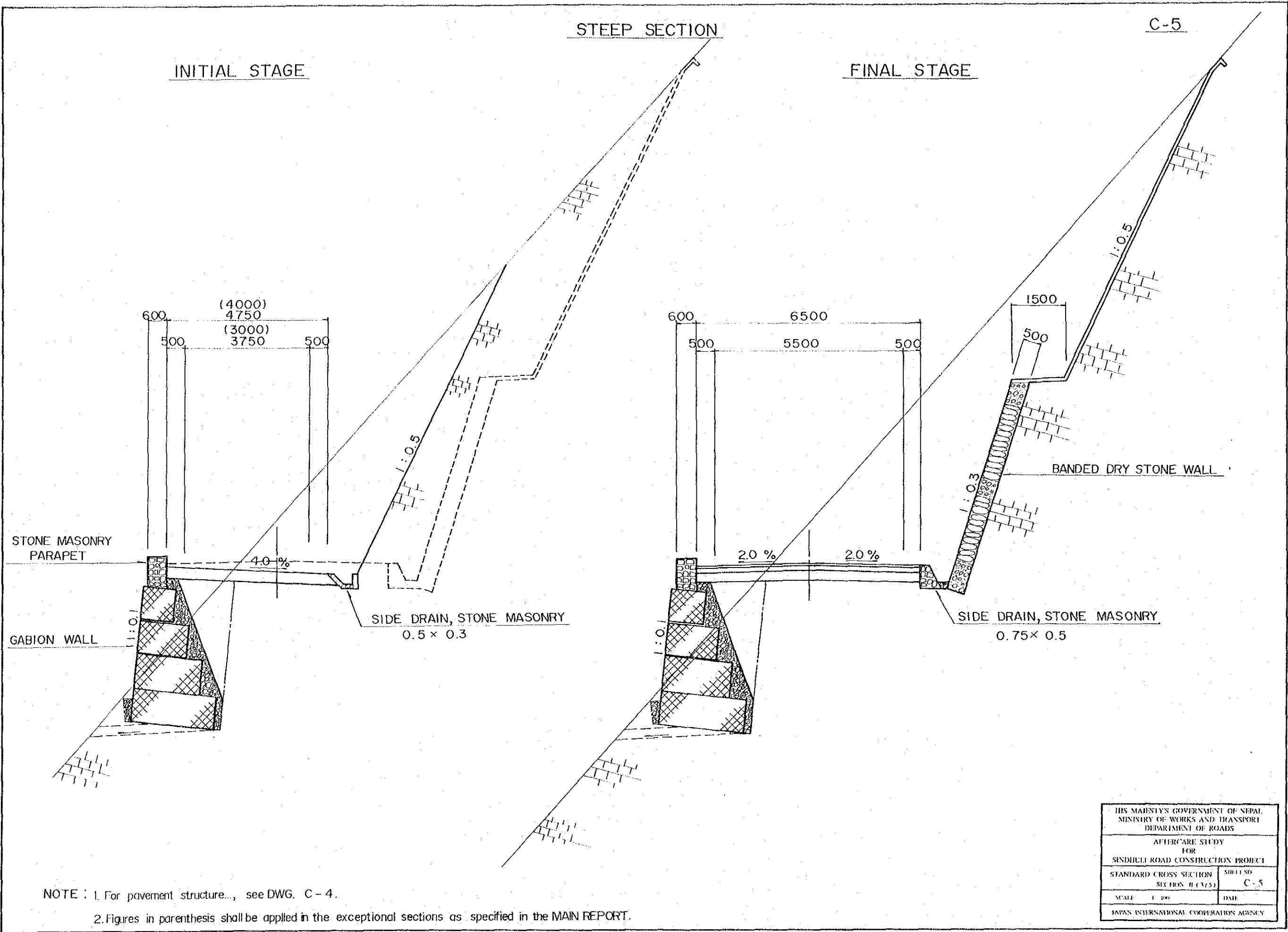

NOTE : 1. For pavement structure..., see DWG. C-4.

2. Figures in parenthesis shall be applied in the exceptional sections as specified in the MAIN REPORT.

HIS MAJESTY'S GOVERNMENT OF NEPAL MINISTRY OF WORKS AND TRANSPORT DEPARTMENT OF ROADS	
AFTER-CARE STUDY FOR SINDHUJI ROAD CONSTRUCTION PROJECT	
STANDARD CROSS SECTION SECTION II (C/5)	SHEET NO C-5
SCALE : 1:100	DATE :
JAPAN INTERNATIONAL COOPERATION AGENCY	

STEEP AND LOOSEN ROCK CONDITION

INITIAL STAGE

FINAL STAGE

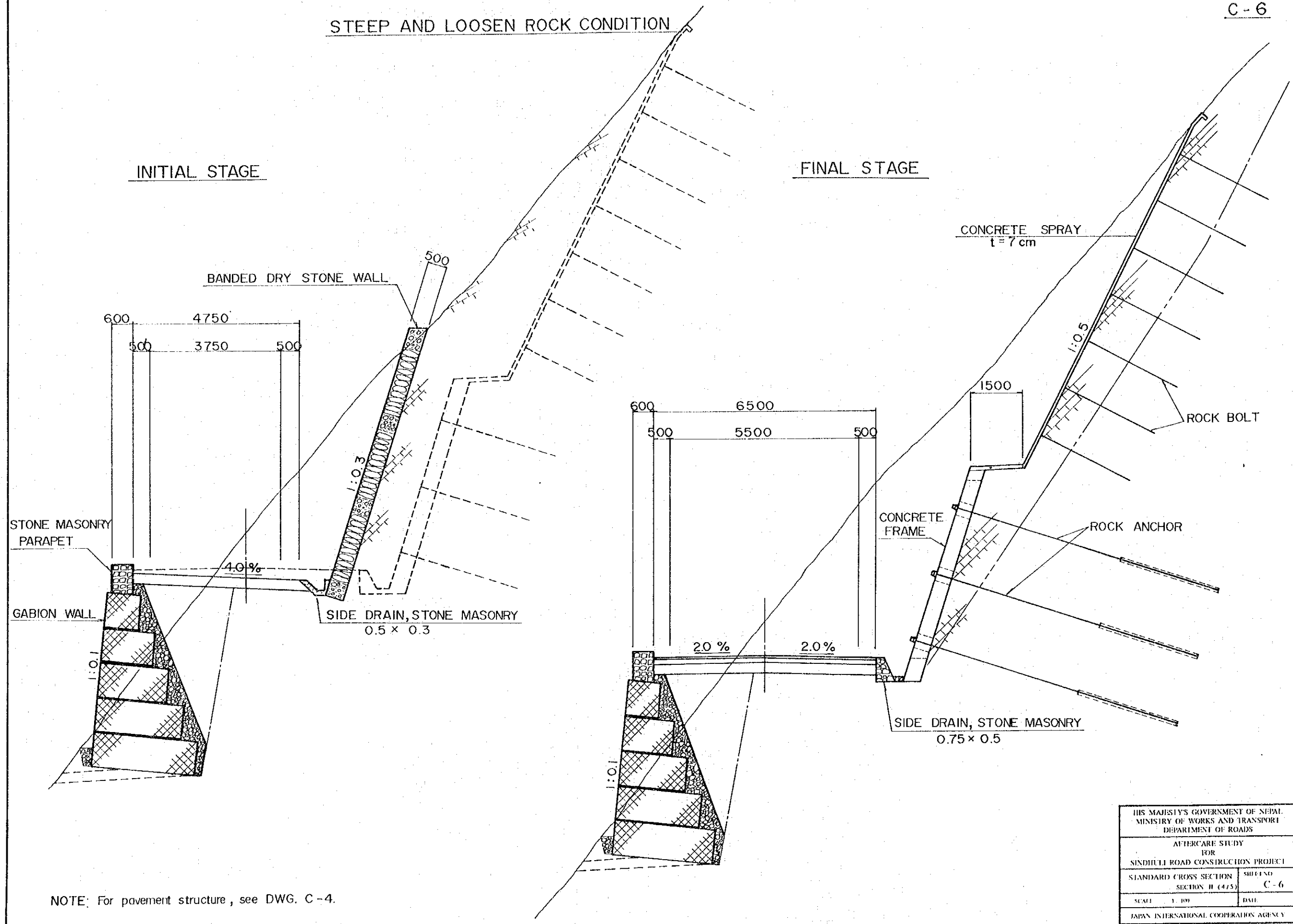

NOTE: For pavement structure, see DWG. C-4.

HIS MAJESTY'S GOVERNMENT OF NEPAL MINISTRY OF WORKS AND TRANSPORT DEPARTMENT OF ROADS	
AFTERCARE STUDY FOR SINDHULI ROAD CONSTRUCTION PROJECT	
STANDARD CROSS SECTION SECTION II (4/5)	SHEET NO C-6
SCALE 1:100	DATE
JAPAN INTERNATIONAL COOPERATION AGENCY	

INITIAL STAGE

RIVER SIDE

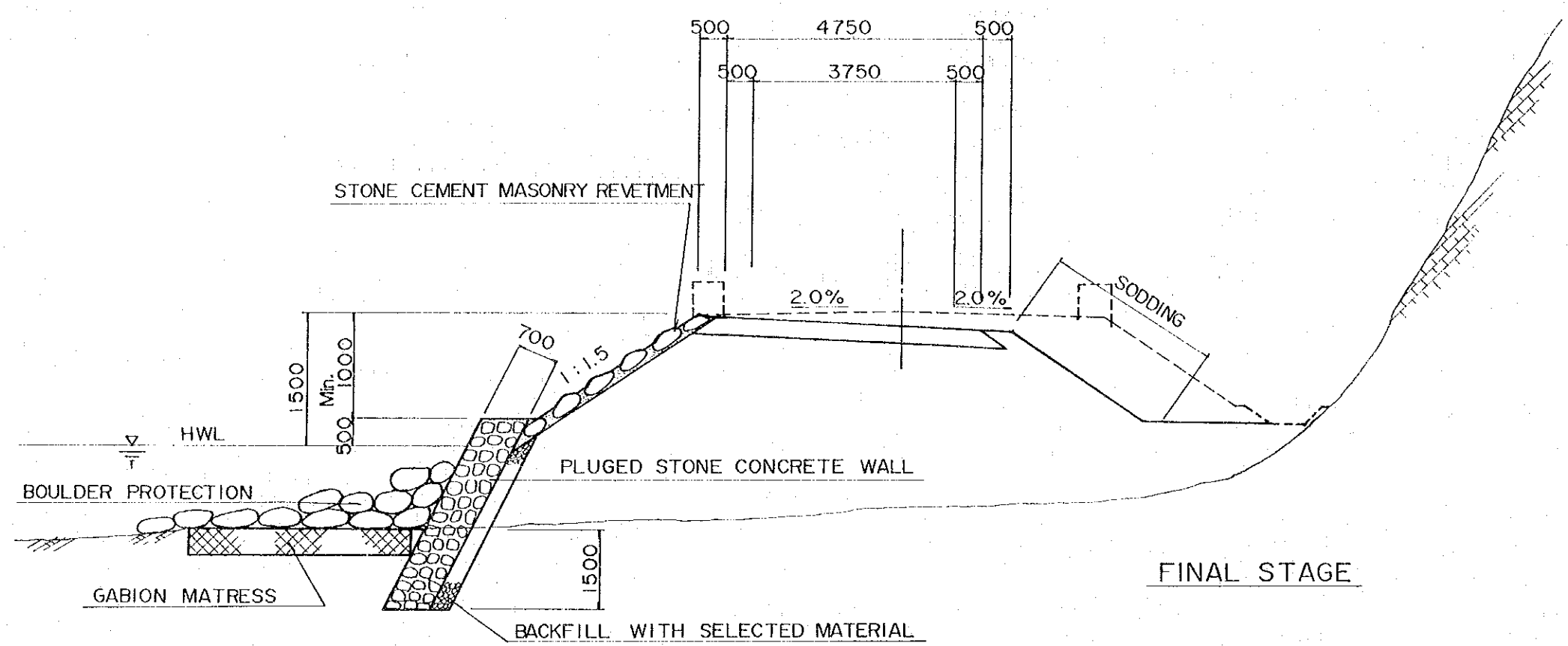

FINAL STAGE

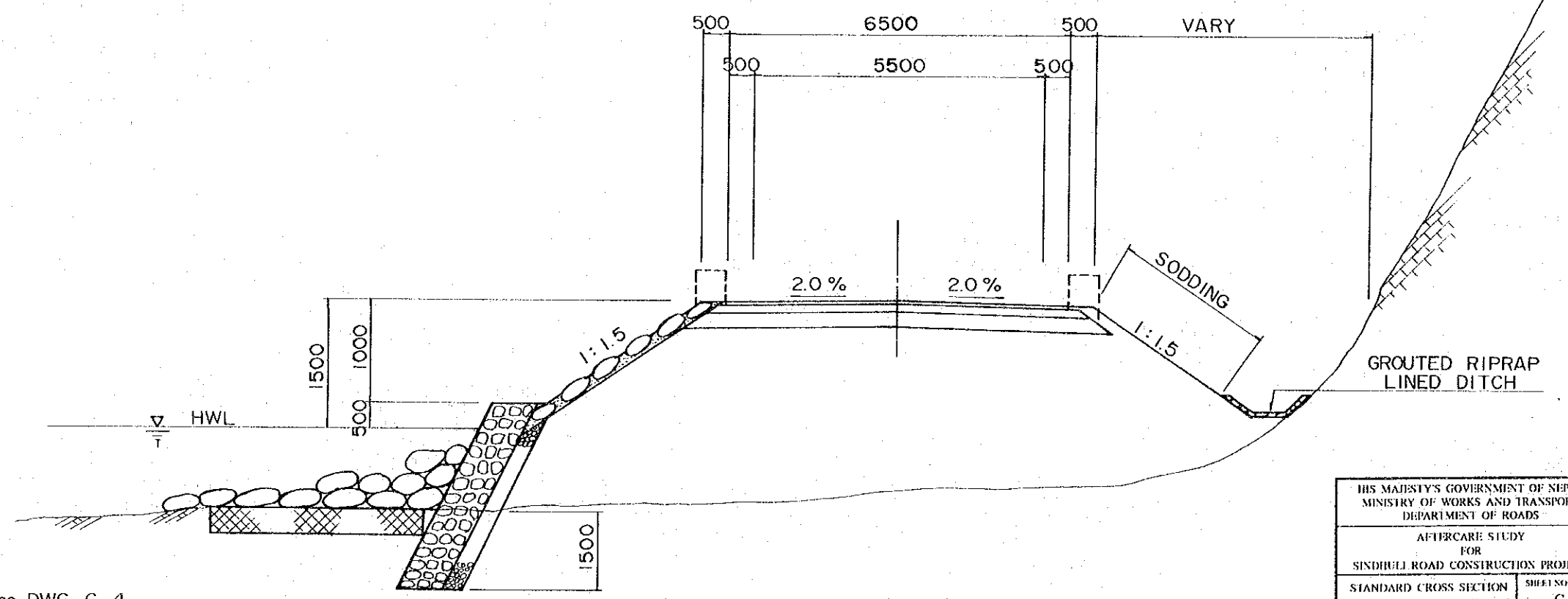

NOTE: For pavement structure, see DWG. C-4.

HIS MAJESTY'S GOVERNMENT OF NEPAL MINISTRY OF WORKS AND TRANSPORT DEPARTMENT OF ROADS	
AFTERCARE STUDY FOR SINDHUJI ROAD CONSTRUCTION PROJECT	
STANDARD CROSS SECTION SECTION II (5/5)	SHEET NO C-7
SCALE: 1:100	DATE
JAPAN INTERNATIONAL COOPERATION AGENCY	

D. RIVER CROSSING STRUCTURES

ESTIMATED QUANTITIES OF MAJOR BRIDGES

MEDIUM & MINOR BRIDGES

STANDARD DESIGN OF MEDIUM & MINOR BRIDGE

TYPICAL SECTION OF CAUSEWAY

MATERIAL LIST OF MINOR CAUSEWAY

ESTIMATED QUANTITIES OF MAJOR BRIDGES

ALT-1.(1)

SEC	NAME OF BRIDGE	STA. NO	TOTAL BRIDGE LENGTH (m)	SPAN ARRANGEMENT (m)	TYPE OF BRIDGE	SUPER -- STRUCTURE						SUB -- STRUCTURE			
						METAL -- BRIDGE			PRESTRESSED CONCRETE BRIDGE			SUB -- STRUCTURE			
						STRUCTURAL STEEL (ton)	CONCRETE (m³)	REINFORCEMENT BAR (kg)	CONCRETE (m³)	HIGH TENSILE WIRE (kg)	REINFORCEMENT BAR (kg)	CONCRETE (m³)	REINFORCEMENT BAR (kg)	EXCAVATION (m³)	GUARD BANK (m²)
I	BHOGATE	78+1000 78+6000	500	20 250	PCB	—	—	—	160	2830	27160	230	13600	720	—
	RATU	125+000 126+7500	1750	70 250	PCB	—	—	—	570	9900	95070	410	24800	1550	1200
	KAMALA	290+9000 292+10000	1200	40 300	PCB	—	—	—	410	8920	65110	320	19100	1100	—
	PHITTANG	323+6500 324+15000	500	20 250	PCB	—	—	—	160	2830	27160	190	11400	730	—
	BUKA	342+9500 343+45000	500	20 250	PCB	—	—	—	160	2830	27160	150	9000	570	—
	GADEULI	351+10000 351+60000	500	20 250	PCB	—	—	—	160	2830	27160	220	13200	730	500
II 1 3	DAUNE	133+2500 133+7500	500	500	STEEL DECK TRUSS	60	60	15930	—	—	—	130	7700	480	—
	NARKE	162+7000 163+25000	550	550	STEEL DECK TRUSS	70	70	17500	—	—	—	130	7700	480	—
	ROSI	215+7500 216+10000	650	650	STEEL THROUGH TRUSS	94	100	25700	—	—	—	210	12500	490	180
TOTAL						224	230	59130	1620	30140	268820	1990	119000	6850	1880

ALT-2.(1)

SEC	NAME OF BRIDGE	STA. NO	TOTAL BRIDGE LENGTH (m)	SPAN ARRANGEMENT (m)	TYPE OF BRIDGE	SUPER -- STRUCTURE						SUB -- STRUCTURE			
						METAL -- BRIDGE			PRESTRESSED CONCRETE BRIDGE			SUB -- STRUCTURE			
						STRUCTURAL STEEL (ton)	CONCRETE (m³)	REINFORCEMENT BAR (kg)	CONCRETE (m³)	HIGH TENSILE WIRE (kg)	REINFORCEMENT BAR (kg)	CONCRETE (m³)	REINFORCEMENT BAR (kg)	EXCAVATION (m³)	GUARD BANK (m²)
I	BHOGATE	78+1000 78+6000	500	20 250	PCB	—	—	—	170	3740	28760	380	22600	960	—
	RATU	125+000 126+7500	1750	70 250	PCB	—	—	—	610	13100	100670	740	44300	2160	1200
	KAMALA	290+9000 292+10000	1200	40 300	PCB	—	—	—	430	11110	69000	550	33300	1500	—
	PHITTANG	323+6500 324+15000	500	20 250	PCB	—	—	—	170	3740	28760	280	16600	890	—
	BUKA	342+9500 343+45000	500	20 250	PCB	—	—	—	170	3740	28760	250	14700	770	—
	GADEULI	351+10000 351+60000	500	20 250	PCB	—	—	—	170	3740	28760	360	21500	970	500
II 1 3	DAUNE	133+2500 133+7500	500	500	STEEL DECK TRUSS	96	70	18280	—	—	—	190	11500	620	—
	NARKE	162+7000 163+25000	550	550	STEEL DECK TRUSS	113	80	20080	—	—	—	190	11500	620	—
	ROSI	215+7500 216+10000	650	650	STEEL THROUGH TRUSS	—	—	—	—	—	—	280	16600	610	180
TOTAL						209	150	38360	1720	39170	284710	3220	192600	9100	1880

ALT-1.(2)

SEC	NAME OF BRIDGE	STA. NO	TOTAL BRIDGE LENGTH (m)	SPAN ARRANGEMENT (m)	TYPE OF BRIDGE	SUPER -- STRUCTURE						SUB -- STRUCTURE			
						METAL -- BRIDGE			PRESTRESSED CONCRETE BRIDGE			SUB -- STRUCTURE			
						STRUCTURAL STEEL (ton)	CONCRETE (m³)	REINFORCEMENT BAR (kg)	CONCRETE (m³)	HIGH TENSILE WIRE (kg)	REINFORCEMENT BAR (kg)	CONCRETE (m³)	REINFORCEMENT BAR (kg)	EXCAVATION (m³)	GUARD BANK (m²)
I	BHOGATE	78+1000 78+6000	500	20 250	PCB	—	—	—	330	5660	54320	450	27200	1440	—
	RATU	125+000 126+7500	1750	70 250	PCB	—	—	—	1150	19800	190130	830	49600	3100	—
	KAMALA	290+9000 292+10000	1200	40 300	PCB	—	—	—	820	17930	130220	640	38200	2190	—
	PHITTANG	323+6500 324+15000	500	20 250	PCB	—	—	—	330	5660	54320	380	22800	1450	—
	BUKA	342+9500 343+45000	500	20 250	PCB	—	—	—	330	5660	54320	300	18000	1140	—
	GADEULI	351+10000 351+60000	500	20 250	PCB	—	—	—	330	5660	54320	440	26400	1460	—
II 1 3	DAUNE	133+2500 133+7500	500	500	STEEL DECK TRUSS	120	130	31850	—	—	—	260	15400	950	—
	NARKE	162+7000 163+25000	550	550	STEEL DECK TRUSS	141	140	35000	—	—	—	260	15400	950	—
	ROSI	215+7500 216+10000	650	650	STEEL THROUGH TRUSS	187	210	51400	—	—	—	410	25000	980	—
TOTAL						448	480	118250	3290	60370	537630	390	238000	13660	—

ALT-2.(2)

SEC	NAME OF BRIDGE	STA. NO	TOTAL BRIDGE LENGTH (m)	SPAN ARRANGEMENT (m)	TYPE OF BRIDGE	SUPER -- STRUCTURE						SUB -- STRUCTURE			
						METAL -- BRIDGE			PRESTRESSED CONCRETE BRIDGE			SUB -- STRUCTURE			
						STRUCTURAL STEEL (ton)	CONCRETE (m³)	REINFORCEMENT BAR (kg)	CONCRETE (m³)	HIGH TENSILE WIRE (kg)	REINFORCEMENT BAR (kg)	CONCRETE (m³)	REINFORCEMENT BAR (kg)	EXCAVATION (m³)	GUARD BANK (m²)
I	BHOGATE	78+1000 78+6000	500	20 250	PCB	—	—	—	80	1920	11830	—	—	—	—
	RATU	125+000 126+7500	1750	70 250	PCB	—	—	—	270	6720	18000	—	—	—	—
	KAMALA	290+9000 292+10000	1200	40 300	PCB	—	—	—	190	5680	12360	—	—	—	—
	PHITTANG	323+6500 324+15000	500	20 250	PCB	—	—	—	80	1920	11830	—	—	—	—
	BUKA	342+9500 343+45000	500	20 250	PCB	—	—	—	80	1920	11830	—	—	—	—
	GADEULI	351+10000 351+60000	500	20 250	PCB	—	—	—	80	1920	11830	—	—	—	—
II 1 3	DAUNE	133+2500 133+7500	500	500	STEEL DECK TRUSS	3	30	7480	—	—	—	—	—	—	—
	NARKE	162+7000 163+25000	550	550	STEEL DECK TRUSS	3	33	8230	—	—	—	—	—	—	—
	ROSI	215+7500 216+10000	650	650	STEEL THROUGH TRUSS	156	130	31580	—	—	—	—	—	—	—
TOTAL						162	193	47290	780	20080	77680	—	—	—	—

NOTE:
 ALT-1.(1) INITIAL STAGE - MINIMAL ONE LANE PLAN
 ALT-1.(2) 2ND STAGE - ADDITIONAL ONE LANE PLAN
 ALT-2.(1) INITIAL STAGE - STANDARD ONE LANE PLAN
 ALT-2.(2) 2ND STAGE - SUPERSTRUCTURE WORKING PLAN

HIS MAJESTY'S GOVERNMENT OF NEPAL MINISTRY OF WORKS AND TRANSPORT DEPARTMENT OF ROADS	
AFTERCARE STUDY FOR SINDHUJI ROAD CONSTRUCTION PROJECT	
ESTIMATED QUANTITIES OF MAJOR BRIDGES	SHEET NO. D - 1
SCALE	DATE
JAPAN INTERNATIONAL COOPERATION AGENCY	

MEDIUM & MINOR BRIDGES

ALT-1.(1)

SEC	NO	STA NO	TOTAL BRIDGE LENGTH (m)	SPAN ARRANGEMENT (m)	TYPE OF BRIDGE	SIZE OF SUB-STRUCTURE (m)	SUPER -- STRUCTURE						SUB -- STRUCTURE			
							METAL BRIDGE			PRESTRESSED CONCRETE BRIDGE			SUB -- STRUCTURE			
							HEIGHT OF ABUTMENT OR PIER	STRUCTURAL STEEL (ton)	CONCRETE (m³)	REINFORCEMENT BAR (kg)	CONCRETE (m³)	HIGH TENSILE WIRE (kg)	REINFORCEMENT BAR (kg)	CONCRETE (m³)	REINFORCEMENT BAR (kg)	EXCAVATION (m³)
I	1	82+1000 82+5000	400	20 20.0	PCB	A-1 7.0 P-1 11.0 A-2 7.0	—	—	—	130	1 550	20 700	180	10 500	610	—
		79+8000 80+2000					26	70	16 700	—	—	—	190	11 000	590	40
I	3	82+1000 82+5000	400	20 20.0	HBB	A-1 10.0 P-1 12.0 A-2 10.0	26	70	16 700	—	—	—	280	16 500	830	—
		90+2000 90+4000					13	30	8 350	—	—	—	300	17 700	920	—
I	5	31+9000 32+1000	200	20.0	HBB	A-1 8.0 A-2 8.0	13	30	8 350	—	—	—	130	7 900	420	—
		251+9000 252+1500					25	30	8 330	—	—	—	190	11 200	590	—
I	7	288+2000 288+4000	200	200	PCB	A-1 8.0 A-2 8.0	—	—	—	60	770	10 350	140	8 700	480	—
		TOTAL														

ALT-2.(1)

SEC	NO	STA NO	TOTAL BRIDGE LENGTH (m)	SPAN ARRANGEMENT (m)	TYPE OF BRIDGE	SIZE OF SUB-STRUCTURE (m)	SUPER -- STRUCTURE						SUB -- STRUCTURE			
							METAL BRIDGE			PRESTRESSED CONCRETE BRIDGE			SUB -- STRUCTURE			
							HEIGHT OF ABUTMENT OR PIER	STRUCTURAL STEEL (ton)	CONCRETE (m³)	REINFORCEMENT BAR (kg)	CONCRETE (m³)	HIGH TENSILE WIRE (kg)	REINFORCEMENT BAR (kg)	CONCRETE (m³)	REINFORCEMENT BAR (kg)	EXCAVATION (m³)
I	1	82+1000 82+5000	400	20 20.0	PCB	A-1 7.0 P-1 11.0 A-2 7.0	—	—	—	140	2 280	21 880	300	18 100	820	—
		79+8000 80+2000					35	60	14 850	—	—	—	290	17 300	770	40
I	3	82+1000 82+5000	400	20 20.0	HBB	A-1 10.0 P-1 12.0 A-2 10.0	35	60	14 850	—	—	—	430	25 600	1 080	—
		90+2000 90+4000					20	30	7 430	—	—	—	440	26 500	1 180	—
I	5	31+9000 32+1000	200	20.0	HBB	A-1 8.0 A-2 8.0	20	30	7 430	—	—	—	200	11 800	540	—
		251+9000 252+1500					25	40	9 250	—	—	—	280	16 800	760	—
I	7	288+2000 288+4000	200	200	PCB	A-1 8.0 A-2 8.0	—	—	—	30	1 140	20 700	220	13 000	620	—
		TOTAL														

ALT-1.(2)

SEC	NO	STA NO	TOTAL BRIDGE LENGTH (m)	SPAN ARRANGEMENT (m)	TYPE OF BRIDGE	SIZE OF SUB-STRUCTURE (m)	SUPER -- STRUCTURE						SUB -- STRUCTURE			
							METAL BRIDGE			PRESTRESSED CONCRETE BRIDGE			SUB -- STRUCTURE			
							HEIGHT OF ABUTMENT OR PIER	STRUCTURAL STEEL (ton)	CONCRETE (m³)	REINFORCEMENT BAR (kg)	CONCRETE (m³)	HIGH TENSILE WIRE (kg)	REINFORCEMENT BAR (kg)	CONCRETE (m³)	REINFORCEMENT BAR (kg)	EXCAVATION (m³)
I	1	82+1000 82+5000	400	20 20.0	PCB	A-1 7.0 P-1 11.0 A-2 7.0	—	—	—	260	3 100	41 390	360	21 380	1 210	—
		79+8000 80+2000					51	130	33 400	—	—	—	370	22 200	1 180	—
I	3	82+1000 82+5000	400	20 20.0	HBB	A-1 10.0 P-1 12.0 A-2 10.0	51	130	33 400	—	—	—	550	33 000	1 660	—
		90+2000 90+4000					26	70	16 700	—	—	—	590	35 400	1 850	—
I	5	31+9000 32+1000	200	20.0	HBB	A-1 8.0 A-2 8.0	26	70	16 700	—	—	—	260	15 800	830	—
		251+9000 252+1500					49	70	16 650	—	—	—	370	22 400	1 170	—
I	7	288+2000 288+4000	200	200	PCB	A-1 8.0 A-2 8.0	—	—	—	130	1 550	20 690	290	17 400	950	—
		TOTAL														

ALT-2.(2)

SEC	NO	STA NO	TOTAL BRIDGE LENGTH (m)	SPAN ARRANGEMENT (m)	TYPE OF BRIDGE	SIZE OF SUB-STRUCTURE (m)	SUPER -- STRUCTURE						SUB -- STRUCTURE			
							METAL BRIDGE			PRESTRESSED CONCRETE BRIDGE			SUB -- STRUCTURE			
							HEIGHT OF ABUTMENT OR PIER	STRUCTURAL STEEL (ton)	CONCRETE (m³)	REINFORCEMENT BAR (kg)	CONCRETE (m³)	HIGH TENSILE WIRE (kg)	REINFORCEMENT BAR (kg)	CONCRETE (m³)	REINFORCEMENT BAR (kg)	EXCAVATION (m³)
I	1	82+1000 82+5000	400	20 20.0	PCB	A-1 7.0 P-1 11.0 A-2 7.0	—	—	—	60	1 180	8 920	—	—	—	—
		79+8000 80+2000					14	21	5 150	—	—	—	—	—	—	—
I	3	82+1000 82+5000	400	20 20.0	HBB	A-1 10.0 P-1 12.0 A-2 10.0	14	21	5 150	—	—	—	—	—	—	—
		90+2000 90+4000					7	10	2 580	—	—	—	—	—	—	—
I	5	31+9000 32+1000	200	20.0	HBB	A-1 8.0 A-2 8.0	7	10	2 580	—	—	—	—	—	—	—
		251+9000 252+1500					8	10	3 200	—	—	—	—	—	—	—
I	7	288+2000 288+4000	200	200	PCB	A-1 8.0 A-2 8.0	—	—	—	30	590	4 460	—	—	—	—
		TOTAL														

NOTE
ALT-1.(1) INITIAL STAGE - ORIGINAL ONE LANE PLAN
ALT-1.(2) 2ND STAGE - ADDITIONAL ONE LANE PLAN
ALT-2.(1) INITIAL STAGE - STANDARD ONE LANE PLAN
ALT-2.(2) 2ND STAGE - SUPERSTRUCTURE WORKING PLAN

HIS MAJESTY'S GOVERNMENT OF NEPAL MINISTRY OF WORKS AND TRANSPORT DEPARTMENT OF ROADS	
AFTERCARE STUDY FOR SINDHURI ROAD CONSTRUCTION PROJECT	
MEDIUM & MINOR BRIDGES	SHEET NO. D-2
SCALE	DATE
JAPAN INTERNATIONAL COOPERATION AGENCY	

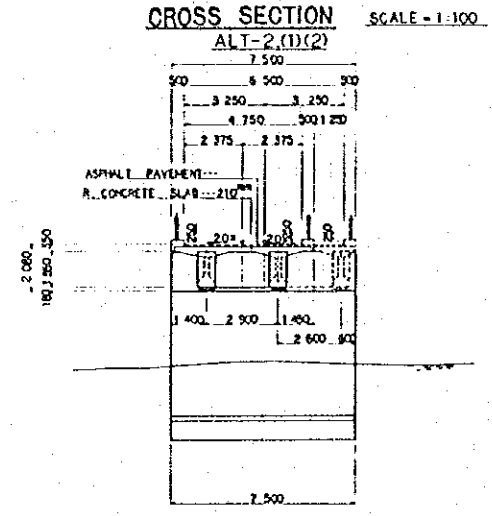
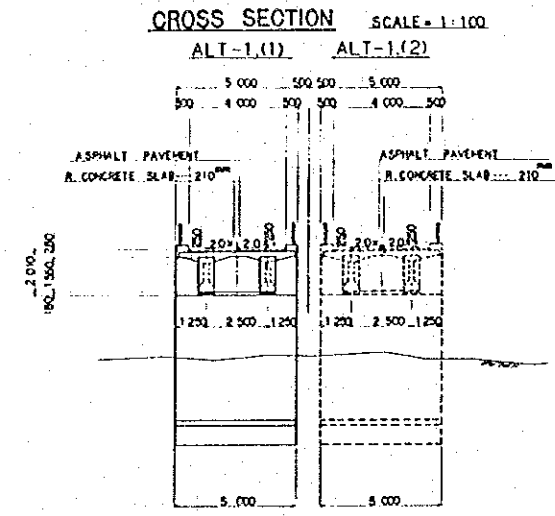
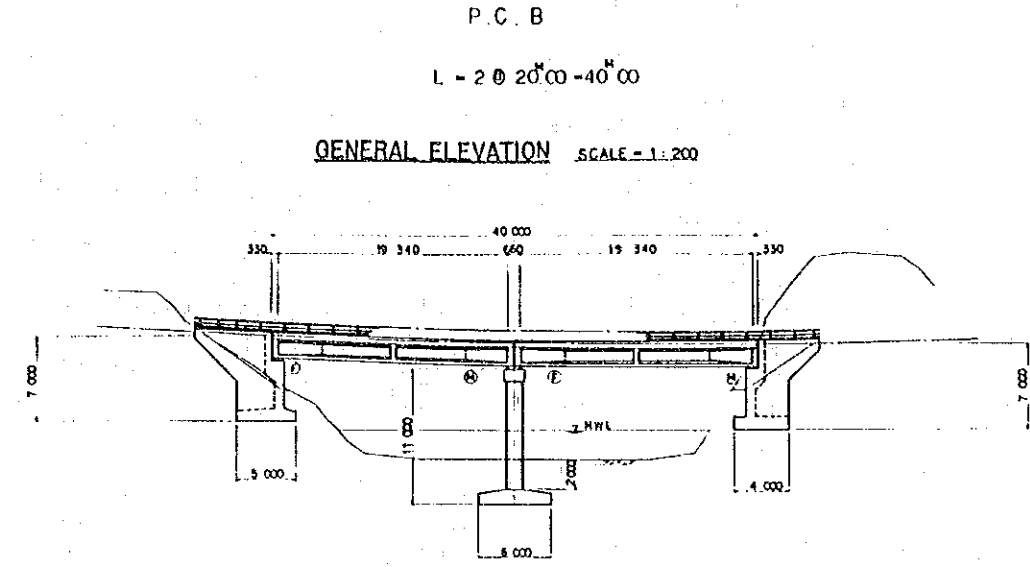
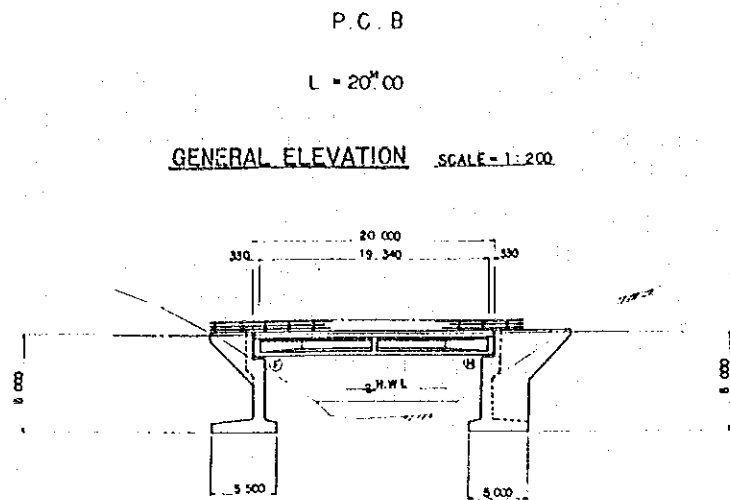

MATERIAL LIST

ITEM	CLASS	UNIT	L = 20.00m				L = 2 @ 20.00m - 40.00m				REMARKS
			ALT-1.(1)	ALT-1.(2)	ALT-2.(1)	ALT-2.(2)	ALT-1.(1)	ALT-1.(2)	ALT-2.(1)	ALT-2.(2)	
SUPER-STRUCTURE											
CONCRETE											
GIRDER	σck=400kg/cm²	m³	28.12	56.24	28.12	14.06	56.24	112.48	56.24	28.12	
CAST IN PLACE	σck=300kg/cm²	m³	3.89	7.78	4.76	3.88	7.78	15.56	9.52	7.78	
CONCRETE	σck=210kg/cm²	m³	25.56	51.12	28.73	8.90	51.12	102.24	57.46	17.80	
FORM	σck=210kg/cm²	m³	7.28	14.56	7.28	3.64	14.56	29.12	14.56	7.28	
GIRDER		m²	154.64	309.28	154.64	77.32	309.28	618.56	309.28	154.64	
CAST IN PLACE		m²	144.04	288.08	163.85	42.37	288.08	576.16	327.30	84.74	
PRESTRESSING WIRE (BAR)											
GIRDER	12112.4	kg	717.34	1434.68	1676.00	538.00	1434.68	2869.36	2152.00	1076.00	
LATERAL TIE	φ23	kg	56.72	113.44	64.55	50.85	113.44	226.88	129.10	101.70	
REINFORCEMENT BAR											
TOTAL	SD-295A	kg	10347.40	20694.80	18942.20	4460.40	20694.80	41389.60	21884.10	8920.80	
SHOE		n	4	8	4	2	8	16	8	4	
EXPANSION JOINT		m	10.00	20.00	11.50	3.50	15.00	30.00	17.25	5.25	
HANDRAIL		m	40.00	80.00	40.00	20.00	80.00	160.00	80.00	40.00	
ASPHALT PAVEMENT		m²	0	160.00	0	130.00	0	320.00	0	260.00	
SUB-STRUCTURE											
EXCAVATION		m³	475.60	951.20	618.00	0	607.10	1214.20	817.30	0	
CONCRETE	σck=210kg/cm²	m³	144.30	288.60	216.40	0	180.90	361.80	301.70	0	
FORM		m³	212.70	425.40	280.20	0	284.50	569.00	417.70	0	
REINFORCEMENT BAR	SD-295A	kg	8.70	17.40	18.00	0	16.50	33.00	18.10	0	
GUARD BANK		m³	0	0	0	0	0	0	0	0	

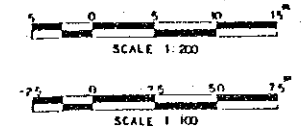

NOTE
 ALT-1.(1) INITIAL STAGE - NORMAL ONE LANE PLAN
 ALT-1.(2) 2ND STAGE - ADDITIONAL ONE LANE PLAN
 ALT-2.(1) INITIAL STAGE - STANDARD ONE LANE PLAN
 ALT-2.(2) 2ND STAGE - SUPERSTRUCTURE WIDTHING PLAN

DESIGN CONDITION

TOTAL BRIDGE LENGTH	20,000, 40,000
SPAN LENGTH	19,340
SPAN	19,340
WIDTH	4,000, 4,750, 6,500
LIVE LOAD	TL - 20
IMPACT COEFFICIENT	1+0.25C
WIND COEFFICIENT	0.4+0.18
ANGLE OF SKEW	
ANGLE OF CURVATURE	
LONGITUDINAL SLOPE	

HIS MAJESTY'S GOVERNMENT OF NEPAL
 MINISTRY OF WORKS AND TRANSPORT
 DEPARTMENT OF ROADS

AFTERCARE STUDY
 FOR
 SINDHUJI ROAD CONSTRUCTION PROJECT

STANDARD DESIGN OF MEMBRANES MINOR BRIDGE (1/2) SPEC I, II-3	SHEET NO D-3
SCALE	DATE
JAPAN INTERNATIONAL COOPERATION AGENCY	

H. B. B

L = 20^m00, 25^m00

GENERAL ELEVATION SCALE = 1:200

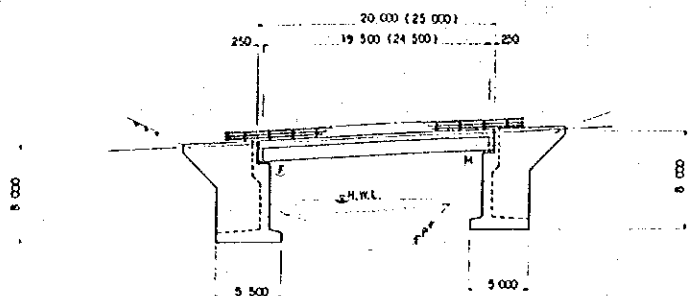

H. B. B

L = 2 @ 20^m00 - 40^m00

GENERAL ELEVATION SCALE = 1:200

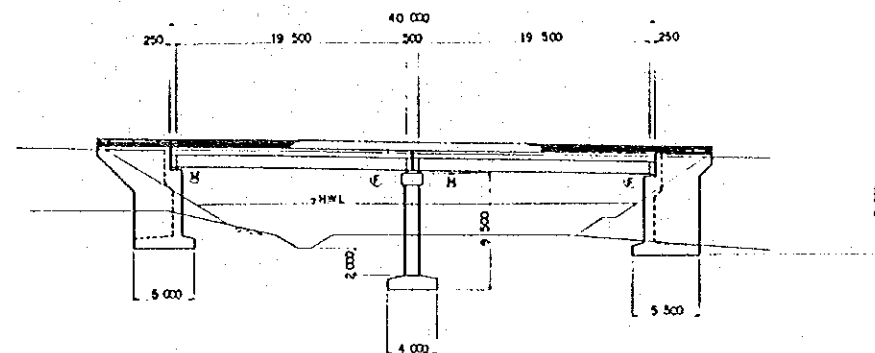

L - 20^m00
CROSS SECTION SCALE = 1:100
ALT-1.(1) ALT-1.(2)

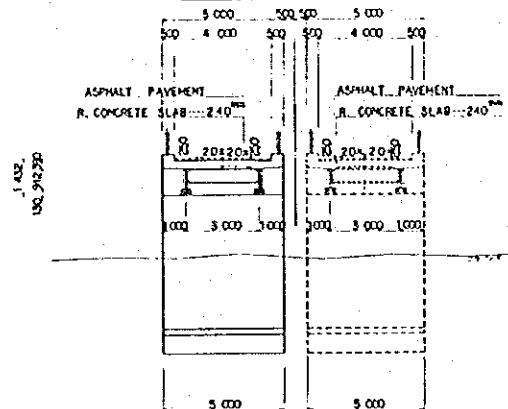

L - 25^m00
CROSS SECTION SCALE = 1:100
ALT-1.(1) ALT-1.(2)

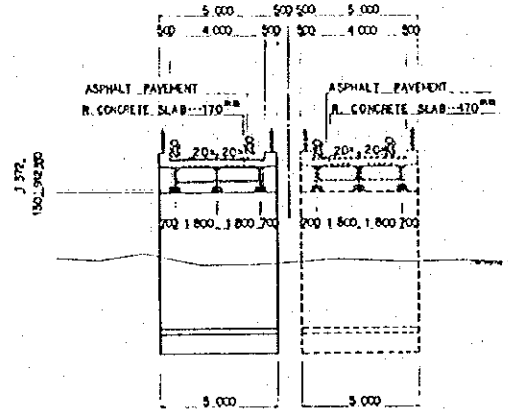

L - 20^m00, 25^m00
CROSS SECTION SCALE = 1:100
ALT-2.(1)(2)

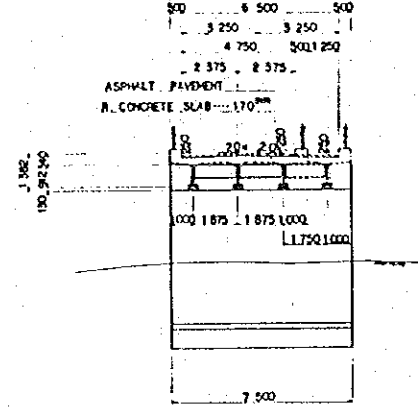

MATERIAL LIST

ITEM	CLASS	UNIT	L = 20.00m				L = 2 @ 20.00m = 40.00m				REMARKS
			ALT-1.(1)	ALT-1.(2)	ALT-2.(1)	ALT-2.(2)	ALT-1.(1)	ALT-1.(2)	ALT-2.(1)	ALT-2.(2)	
SUPER-STRUCTURE											
STEEL											
GIRDER	SA1508F	kg	11670	23340	17510	5810	23310	45550	35020	11680	
OTHERS	SA1111F	kg	1130	2260	2100	1050	2250	4520	4200	2100	
SHOE		n	4	8	8	2	8	16	8	4	
HANDRAIL		m	40.00	80.00	40.00	20.00	80.00	160.00	80.00	40.00	
CONCRETE	σck=300kg/cm ²	m ³	33.40	66.80	29.70	10.30	66.80	133.60	59.40	29.60	
FORM		m ²	122.00	244.00	128.00	45.00	244.00	488.00	256.00	90.00	
ASPHALT PAVEMENT		m ²	0	160.00	0	130.00	0	320.00	0	260.00	
EXPANSION JOINT		m	10.00	20.00	11.50	3.50	20.00	40.00	23.00	7.00	
SUB-STRUCTURE											
EXCAVATION		m ³	921.10	1842.20	1182.70	0	587.70	1175.40	170.90	0	
CONCRETE	σck=210kg/cm ²	m ³	294.90	589.80	442.20	0	185.40	370.80	288.40	0	
FORM		m ²	318.90	637.80	464.40	0	259.90	519.80	423.90	0	
REINFORCEMENT BAR	S0-2551	t	17.70	35.40	26.50	0	11.10	22.20	17.30	0	
GUARD BANK		m ²	0	0	0	0	40.00	0	40.00	0	

* REINFORCEMENT BAR ... 250kg/m³

DESIGN CONDITION	
TOTAL BRIDGE LENGTH	20,000, 25,000, 40,000
GREEN LENGTH	19,500, 24,500
SPAN	19,500, 24,500
WIDTH	4,000, 4,750, 6,500
LIVE LOAD	TL - 20
IMPACT COEFFICIENT	1+20/150+1
SEISMIC COEFFICIENT	8% - C 14
ANGLE OF SKEW	-----
RADIUS OF CURVATURE	-----
LONGITUDINAL SLOPE	-----



NOTE
 ALT-1.(1) INITIAL STAGE - MINIMAL ONE LANE PLAN
 ALT-1.(2) 2ND STAGE - ADDITIONAL ONE LANE PLAN
 ALT-2.(1) INITIAL STAGE - STANDARD ONE LANE PLAN
 ALT-2.(2) 2ND STAGE - SUPERSTRUCTURE WORKING PLAN

THIS MAJESTY'S GOVERNMENT OF SINDH
 MINISTRY OF WORKS AND TRANSPORT
 DEPARTMENT OF ROADS

AFTERCARE STUDY
 FOR
 SINDHULI ROAD CONSTRUCTION PROJECT

STANDARD DESIGN OF MINOR BRIDGE (2/2) SEC 1.1.D.3

SCALE: D-4

DATE: DASH

JAPAN INTERNATIONAL COOPERATION AGENCY

GENERAL ELEVATION SCALE = 1:200

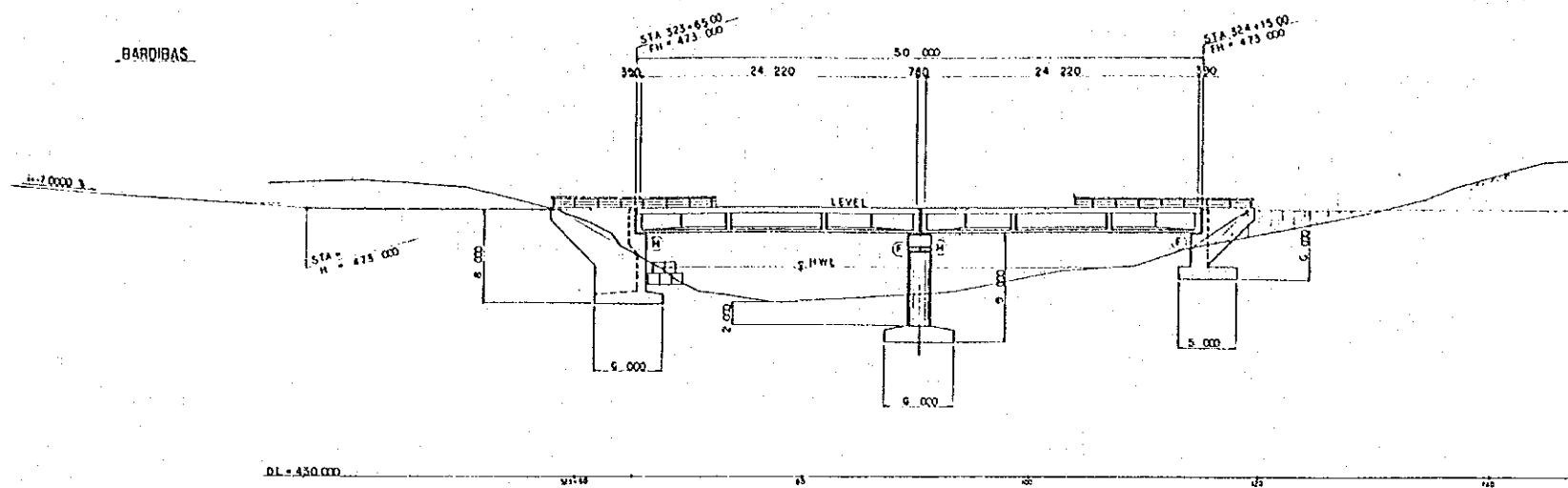

CROSS SECTION SCALE = 1:100

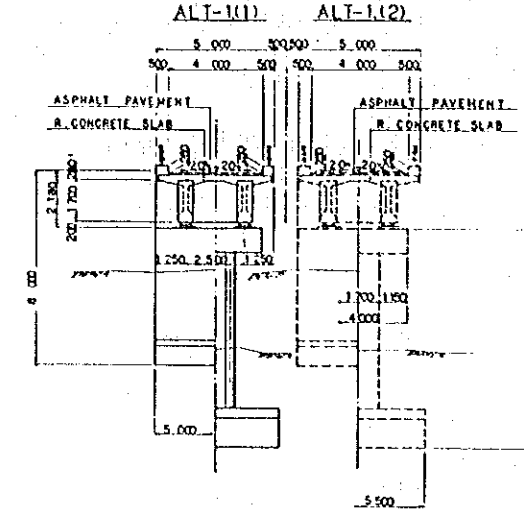

GENERAL PLAN SCALE = 1:200

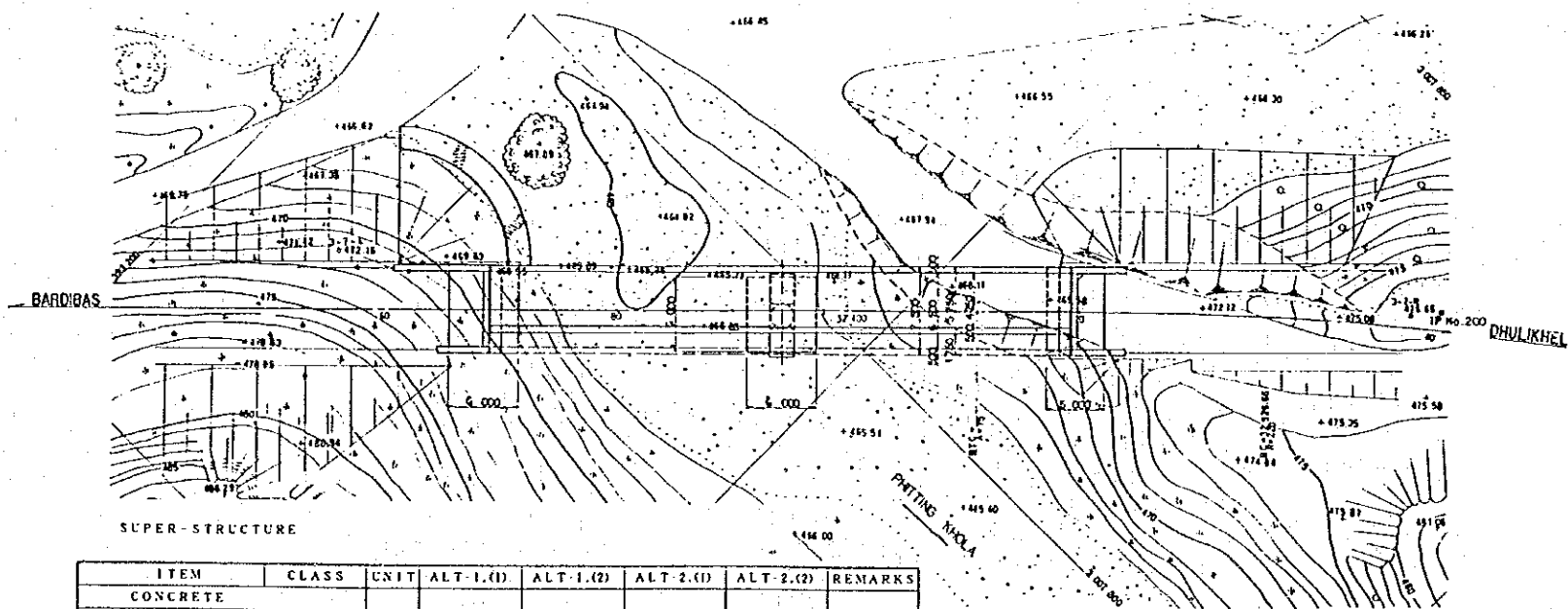

ALT-2(1)(2)

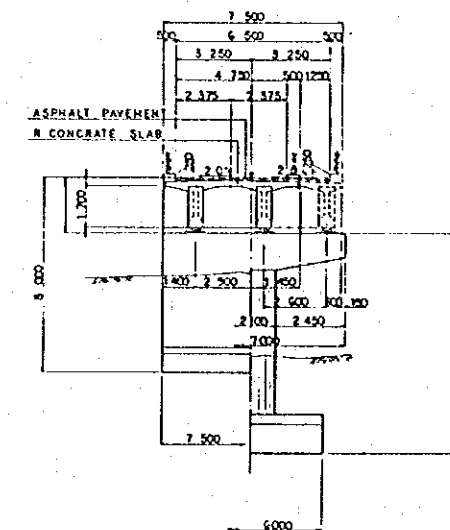

ITEM	CLASS	UNIT	ALT-1.(1)	ALT-1.(2)	ALT-2.(1)	ALT-2.(2)	REMARKS
CONCRETE							
GIRDER	ack-400g/cu ³	m ³	72.08	144.16	72.08	36.04	
CAST IN PLACE	ack-300g/cu ³	m ³	10.08	20.16	12.34	10.28	
PLACE	ack-210g/cu ³	m ³	63.42	126.81	11.26	22.12	
CONCRETE	ack-210g/cu ³	m ³	18.06	36.12	18.06	9.03	
FORM							
GIRDER		m ²	415.04	830.08	415.04	207.52	
CAST IN PLACE		m ²	361.48	722.96	413.24	109.04	
PRESTRESSING WIRE (BAR)							
GIRDER	12712.4	kg	2876.88	5353.16	3569.20	1784.60	
LATERAL TIE	#23	kg	151.26	302.52	172.12	135.62	
REINFORCEMENT BAR							
TOTAL	SD295A	kg	27161.60	54323.60	28763.40	11832.00	
SHOE		n	8	16	8	4	
EXPANSION JOINT		n	15.00	30.00	17.25	5.25	
HANDRAIL		n	100.00	200.00	100.00	50.00	
ASPHALT PAVEMENT		m ²	0	400.00	0	325.00	

SUB-STRUCTURE

ITEM	CLASS	UNIT	ALT-1.(1)	ALT-1.(2)	ALT-2.(1)	ALT-2.(2)	REMARKS
EXCAVATION		m ³	727.20	1454.40	851.70	0	
CONCRETE	ack-210g/cu ³	m ³	189.40	378.80	277.30	0	
FORM		m ²	286.20	533.60	360.40	0	
REINFORCEMENT BAR	SD-295A	kg	11.40	22.80	15.60	0	
GUARD BANK		m ²	0	0	0	0	

DESIGN CONDITION	
TOTAL BRIDGE LENGTH	50.000
BRIDGE LENGTH	24.000
SPAN	24.220
WIDTH	4.000 - 4.750 - 6.500
LIVE LOAD	TL-20
IMPACT COEFFICIENT	1 + 0.203
SEISMIC COEFFICIENT	SA = 0.14
ANGLE OF SKEW	0 = 90°
ANGLE OF CURVATURE	
LONGITUDINAL SLOPE	LEVEL

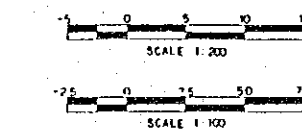

NOTE
 ALT-1.(1) INITIAL STAGE - INITIAL ONE LANE PLAN
 ALT-1.(2) 2ND STAGE - ADDITIONAL ONE LANE PLAN
 ALT-2.(1) INITIAL STAGE - STANDARD ONE LANE PLAN
 ALT-2.(2) 2ND STAGE - SUPERSTRUCTURE WORKING PLAN

THE MAJESTY'S GOVERNMENT OF NEPAL
 MINISTRY OF WORKS AND TRANSPORT
 DEPARTMENT OF ROADS
 AFTER-CARE STUDY
 FOR
 SINDHUJI ROAD CONSTRUCTION PROJECT
 (SEC - 1) PHITANG B. SITE NO. D-5
 SCALE: DATE
 JAPAN INTERNATIONAL COOPERATION AGENCY

GENERAL ELEVATION SCALE = 1 : 200

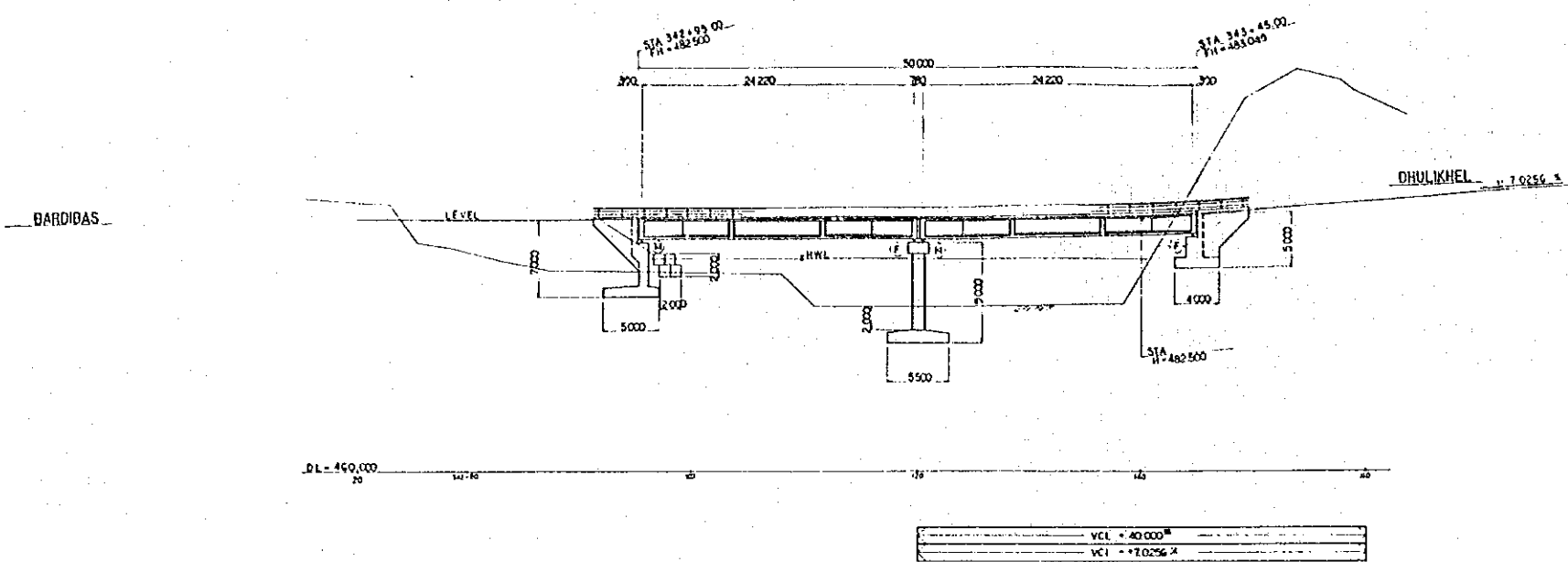

CROSS SECTION SCALE = 1 : 100

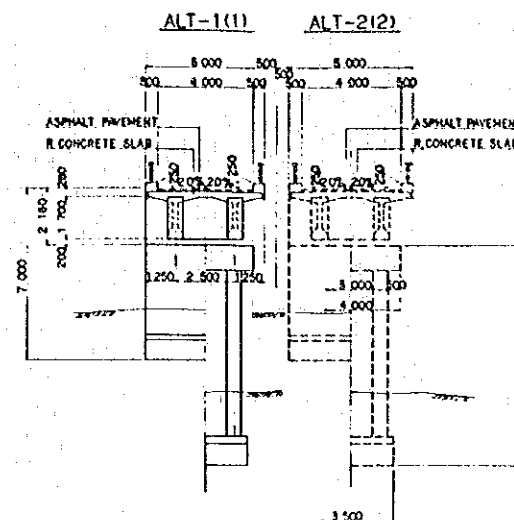

GENERAL PLAN SCALE = 1 : 200

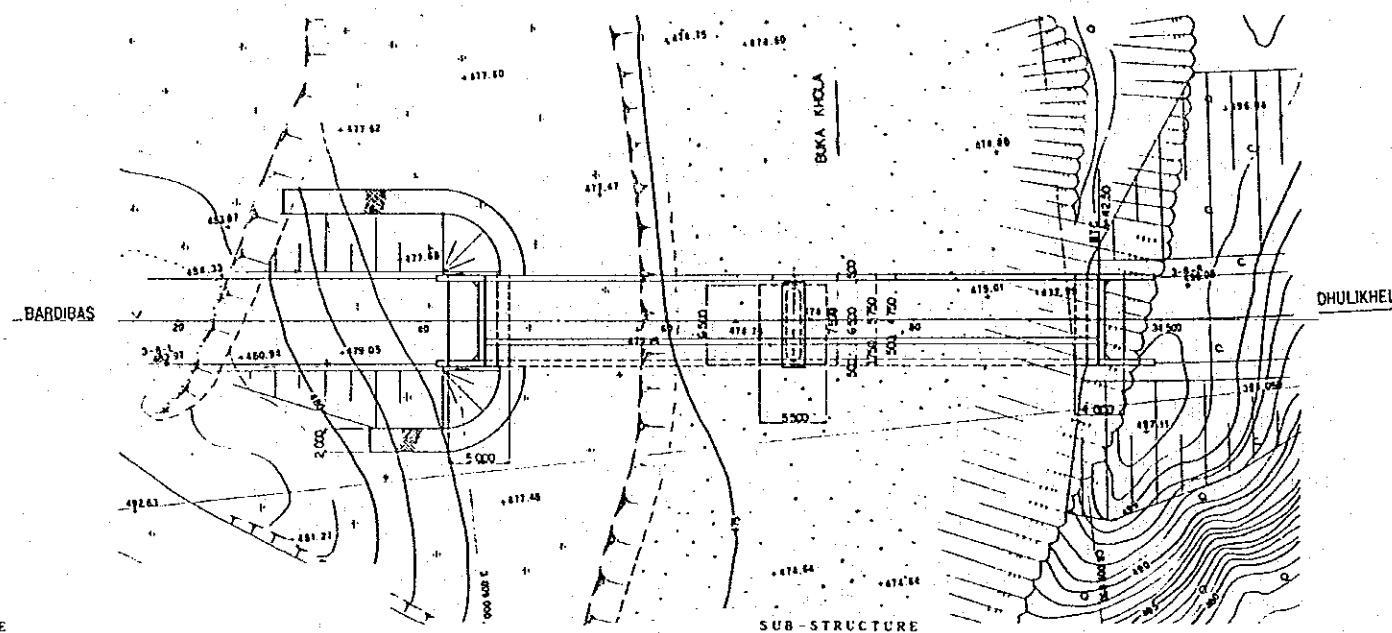

ALT-2(1)(2)

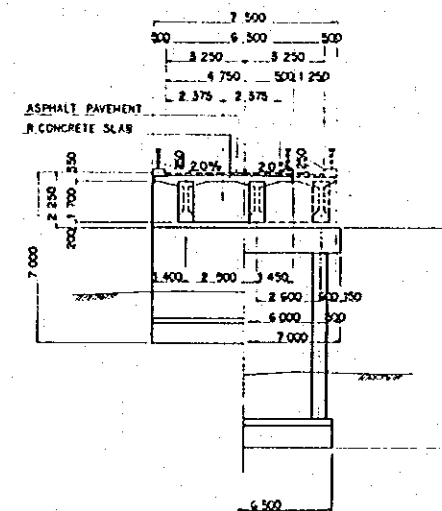

SUPER-STRUCTURE

ITEM	CLASS	UNIT	ALT-1.(1)	ALT-1.(2)	ALT-2.(1)	ALT-2.(2)	REMARKS
CONCRETE							
GIRDER	ack-100kg/cm ²	m ³	72.08	144.16	72.08	36.04	
CAST IN PLACE	ack-300kg/cm ²	m ³	10.08	20.16	12.34	10.28	
	ack-210kg/cm ²	m ³	63.92	126.84	71.26	22.12	
CONCRETE	ack-210kg/cm ²	m ³	18.06	36.12	18.06	9.03	
FORM							
GIRDER		m ²	415.04	830.08	415.04	207.52	
CAST IN PLACE		m ²	361.48	722.95	412.24	109.04	
PRESTRESSING WIRE (BAR)							
GIRDER	I2712.1	kg	2676.88	5353.76	3569.20	1784.60	
LATERAL TIE	#23	kg	151.26	302.52	172.12	135.62	
REINFORCEMENT BAR							
TOTAL	S02554	kg	27161.80	54323.60	28763.10	11832.00	
SHOE							
EXPANSION JOINT		m	15.00	30.00	17.25	5.25	
HANDRAIL		m	100.00	200.00	100.00	50.00	
ASPHALT PAVEMENT		m ²	0	400.00	0	325.00	

SUB-STRUCTURE

ITEM	CLASS	UNIT	ALT-1.(1)	ALT-1.(2)	ALT-2.(1)	ALT-2.(2)	REMARKS
EXCAVATION		m ³	572.00	1144.00	770.00	0	
CONCRETE	ack-210kg/cm ²	m ³	149.20	298.40	246.50	0	
FORM		m ²	239.40	478.80	350.00	0	
REINFORCEMENT BAR	S0-2554	t	8.00	16.00	14.70	0	
GUARD BANK		m ³	0	0	0	0	

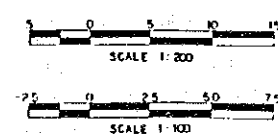

DESIGN CONDITION	
TOTAL BRIDGE LENGTH	50 ^m 030
BRIDGE LENGTH	24 ^m 220
SPAN	24 ^m 220
WIDTH	4 ^m 000 - 4 ^m 750 - 6 ^m 500
LIVE LOAD	TL-20
IMPACT COEFFICIENT	1 + 0.201
SEISMIC COEFFICIENT	KA = 0.16
ANGLE OF SKEW	0 - 90°
ANGLE OF CURVATURE	
LONGITUDINAL SLOPE	VCL = +7.0256 %

NOTE

- ALT-1.(1) INITIAL STAGE - MINIMAL ONE LANE PLAN
- ALT-1.(2) 2ND STAGE - ADDITIONAL ONE LANE PLAN
- ALT-2.(1) INITIAL STAGE - STANDARD ONE LANE PLAN
- ALT-2.(2) 2ND STAGE - SUPERSTRUCTURE WORKING PLAN

THE MAJESTY'S GOVERNMENT OF NEPAL
MINISTRY OF WORKS AND TRANSPORT
DEPARTMENT OF ROADS

AFTERCARE STUDY FOR SINDHULI ROAD CONSTRUCTION PROJECT	
(SEC - 1) BUKA BL.	SHEET NO. D-6
SCALE	DATE
JAPAN INTERNATIONAL COOPERATION AGENCY	

GENERAL ELEVATION SCALE = 1:200

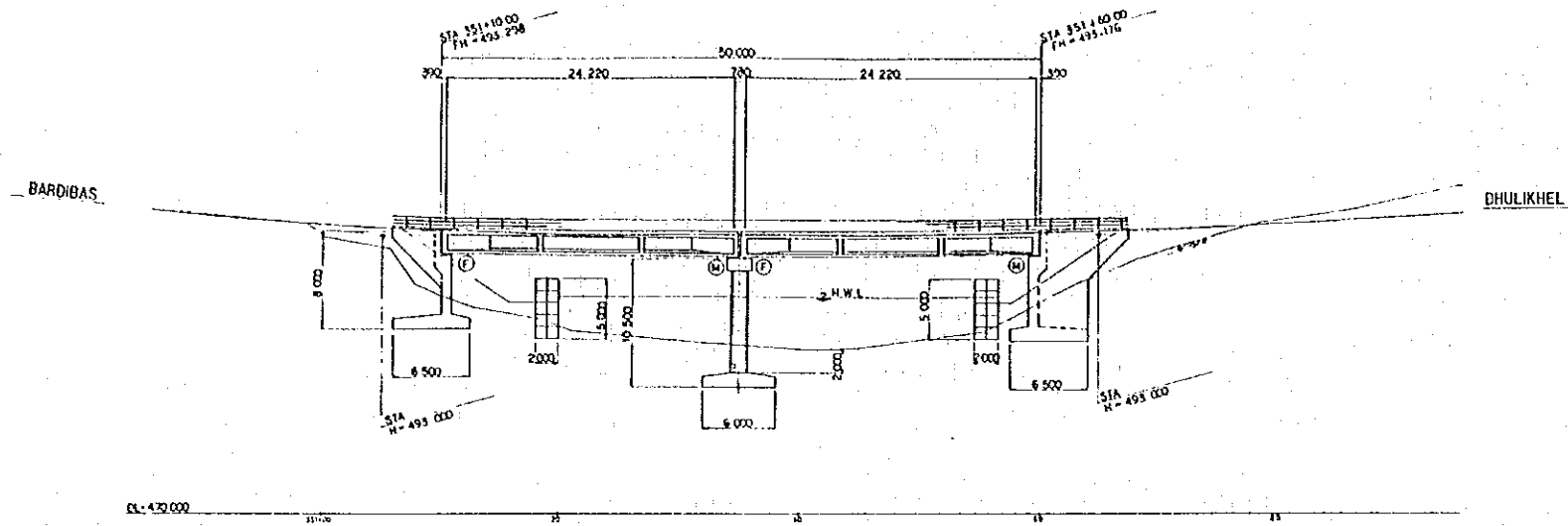

CROSS SECTION SCALE = 1:100

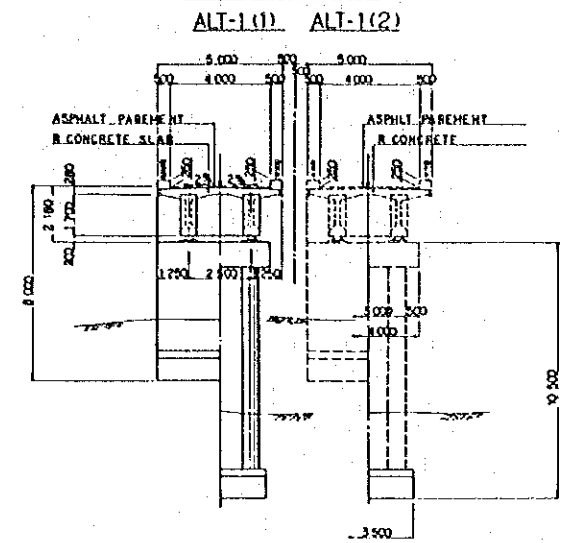

GENERAL PLAN SCALE = 1:200

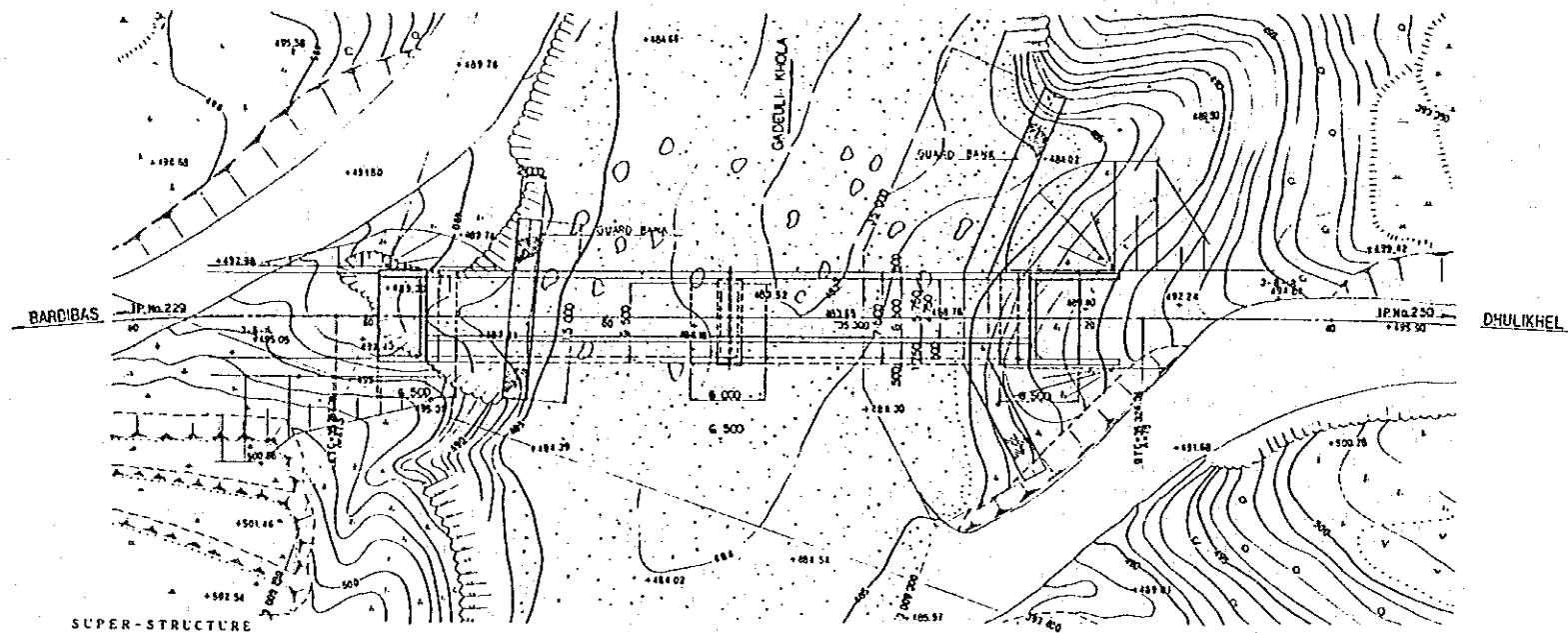

ALT-2(1)&(2)

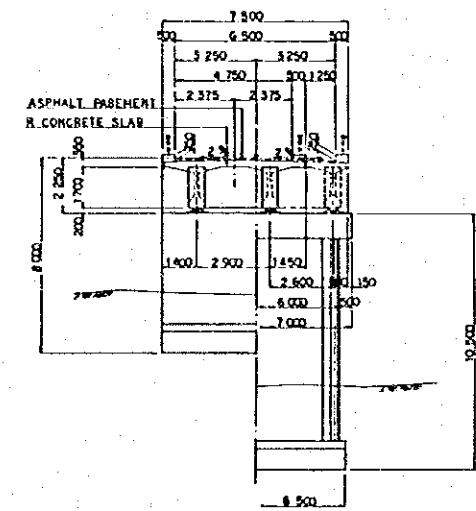

SUPER-STRUCTURE

ITEM	CLASS	UNIT	ALT-1.(1)	ALT-1.(2)	ALT-2.(1)	ALT-2.(2)	REMARKS
CONCRETE							
GIRDER	ack-400kg/cu ³	m ³	72.08	144.16	72.08	36.04	
CAST IN PLACE	ack-300kg/cu ³	m ³	10.08	20.16	12.34	10.28	
CONCRETE	ack-210kg/cu ³	m ³	83.42	176.54	71.26	22.12	
CONCRETE	ack-210kg/cu ³	m ³	18.05	36.12	18.05	9.03	
FORM							
GIRDER		m ²	415.01	830.08	415.01	207.52	
CAST IN PLACE		m ²	361.48	722.95	413.24	169.01	
PRESTRESSING WIRE (BAR)							
GIRDER	12T12.4	kg	2676.88	5353.76	3569.20	1784.60	
LATERAL TIE	#23	kg	151.26	302.52	172.12	135.62	
REINFORCEMENT BAR							
TOTAL	SD235A	kg	27161.80	54323.60	28763.40	11832.00	
SILOE		n	8	16	8	4	
EXPANSION JOINT		n	15.00	30.00	17.25	5.25	
HANDRAIL		n	190.00	380.00	190.00	50.00	
ASPHALT PAVEMENT		m ²	0	400.00	0	325.00	

SUB-STRUCTURE

ITEM	CLASS	UNIT	ALT-1.(1)	ALT-1.(2)	ALT-2.(1)	ALT-2.(2)	REMARKS
EXCAVATION		m ³	729.00	1458.00	973.50	0	
CONCRETE	ack-210kg/cu ³	m ³	220.10	440.20	358.00	0	
FORM		m ²	320.30	640.60	460.50	0	
REINFORCEMENT BAR	SD-235A	t	12.20	24.40	21.50	0	
GUARD BANK		m ³	500.00	0	500.00	0	

DESIGN CONDITION	
TOTAL BRIDGE LENGTH	50.000
GIRDER LENGTH	24.000
SPAN	24.000
WIDTH	4.000, 4.750, 6.500
LOAD	TL - 20
IMPACT COEFFICIENT	1 + 0.203
SEISMIC COEFFICIENT	0.10
ANGLE OF BENCH	8 - 90°
RADIUS OF CURVATURE	
LONGITUDINAL SLOPE	VCI = +10.5963% + 6.2500%



NOTE
 ALT-1.(1) INITIAL STAGE - INITIAL ONE LANE PLAN
 ALT-1.(2) 2ND STAGE - ADDITIONAL ONE LANE PLAN
 ALT-2.(1) INITIAL STAGE - STANDARD ONE LANE PLAN
 ALT-2.(2) 2ND STAGE - SUPERSTRUCTURE YIELDING PLAN

HIS MAJESTY'S GOVERNMENT OF NEPAL
 MINISTRY OF WORKS AND TRANSPORT
 DEPARTMENT OF ROADS

AFRICARE STUDY
 FOR
 SINDHUJI ROAD CONSTRUCTION PROJECT

(SEC - 1) GADEULI Br. SHEET NO. 13-7

SCALE DATE

JAPAN INTERNATIONAL COOPERATION AGENCY