

JAPAN INTERNATIONAL COOPERATION AGENCY
MINISTRY OF WORKS, KINGDOM OF TONGA

BASIC DESIGN STUDY REPORT
FOR
ROAD IMPROVEMENT WORKS IN TONGATAPU
IN
THE KINGDOM OF TONGA
(DRAWINGS)

MARCH 1994



KATAHIRA & ENGINEERS INTERNATIONAL
CHODAI CO., LTD.

JAPAN INTERNATIONAL COOPERATION AGENCY
MINISTRY OF WORKS, KINGDOM OF TONGA

BASIC DESIGN STUDY REPORT
FOR
ROAD IMPROVEMENT WORKS IN TONGATAPU
IN
THE KINGDOM OF TONGA

(DRAWINGS)

MARCH 1994

KATAHIRA & ENGINEERS INTERNATIONAL
CHODAI CO., LTD.



1124295 [5]

INDEX OF DRAWINGS

1. GENERAL

LOCATION MAP	1-1
GENERAL NOTES, LEGEND / ABBREVIATION	1-2

2. TYPICAL CROSS SECTION

SECTION 1-1	2-1 - 2-3
SECTION 1-2	2-4
SECTION 7-1	2-5 - 2-6
SECTION 7-2, 7-3, 7-4	2-7
PAVEMENT SCHEDULE	2-8

3. PLAN & PROFILE

SECTION 1-1	3-1 - 3-13
SECTION 1-2	3-14 - 3-23
SECTION 7-1	3-24 - 3-31
SECTION 7-2	3-31 - 3-48
SECTION 7-3	3-49 - 3-55
SECTION 7-4	3-56 - 3-60

4. DRAINAGE

DRAINAGE PLAN AND PROFILE 1-1	4-1 - 4-5
DRAINAGE PLAN AND PROFILE 1-2	4-6
DRAINAGE CROSS SECTION	4-7 - 4-9
SCHEDULE OF SIDE DITCH, CATCH BASIN, AND DRAINAGE	4-10
TYPICAL DETAILS OF PRECAST BOX CULVERT, π TYPE, AND CATCH BASIN	4-11
STANDARD HEADWALL FOR REINFORCED CONCRETE PIPE CULVERT AND EXISTING DRAINAGE SYSTEM	4-12

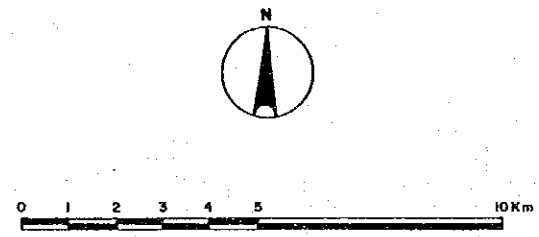
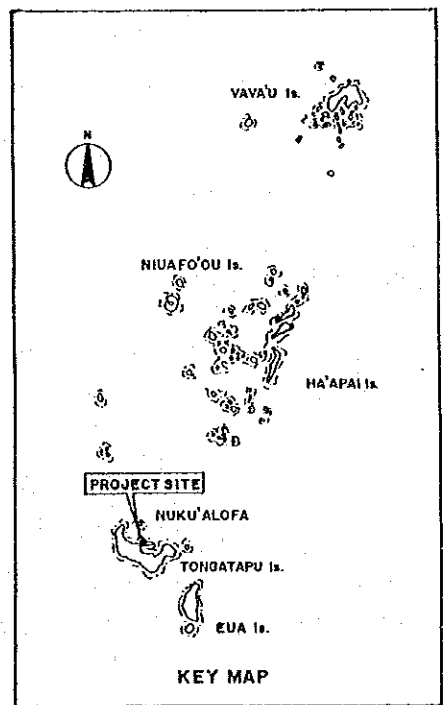
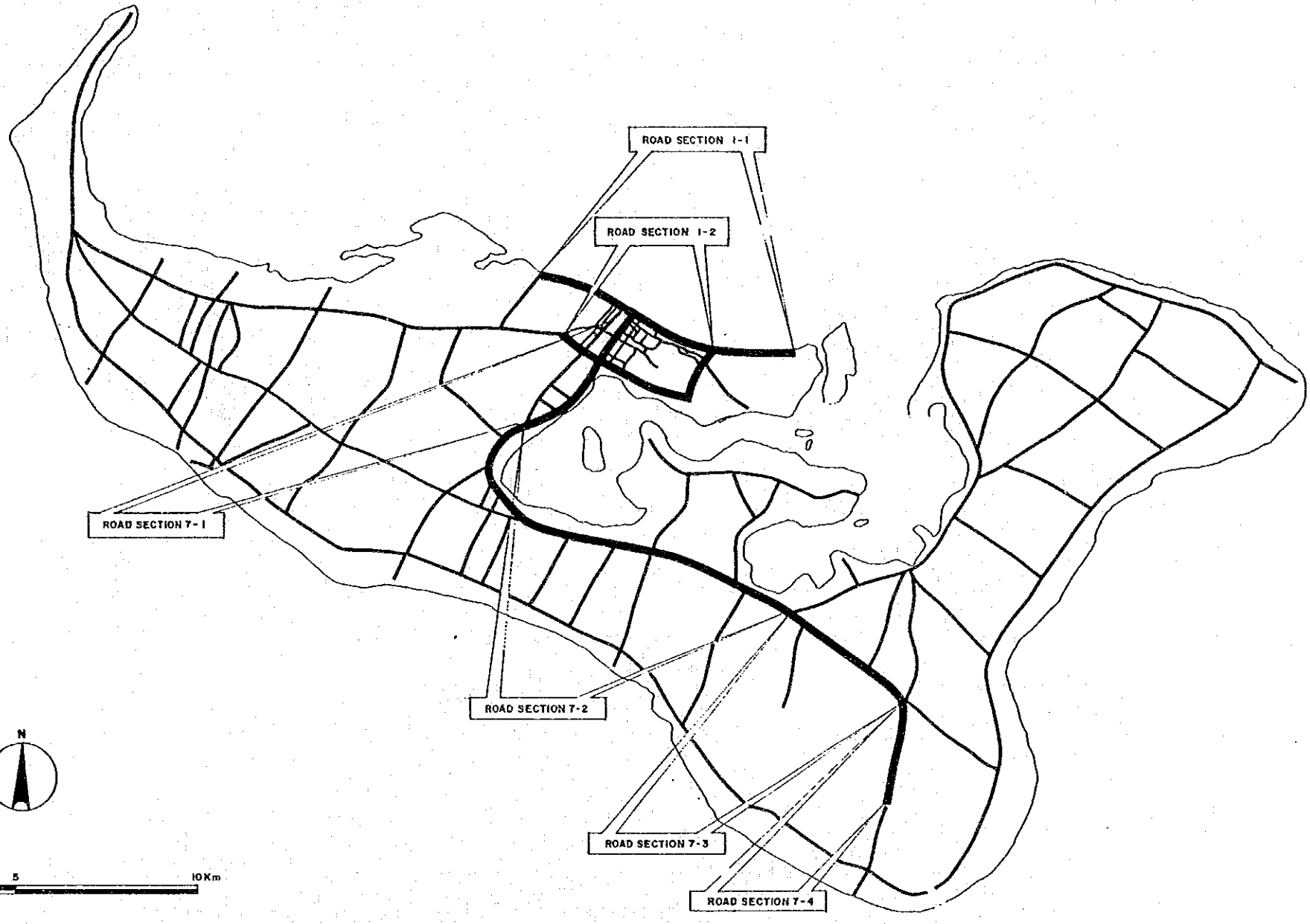

LOCATION MAP
TONGATAPU ISLAND

LEGEND

EXISTING TOPOGRAPHIC FEATURES

	EDGE OF CARRIAGEWAY
	CONTOUR LINES AT 0.5m. INTERVAL
	FENCE LINE
	POWER POLE
	TELEPHONE CABLE JOINT
	TELEPHONE POLE
	SIGN POST
	DRAINAGE
	REVETMENT
	BUILDING / HOUSE
	DROP INLET

NEW DESIGN FEATURES

	PROPOSED CENTER LINE
	PROPOSED ROADWAY
	POINT OF TANGENCY
	SIDE DITCH & DROP INLET
	CROSS DRAINAGE (PIPE / BOX CULVERTS)
	PIPE CULVERT
	BOX CULVERT
	WATER FLOW DIRECTION
	PROPOSED HEIGHT (OVERLAY)
	BENCH MARK
	GRID COORDINATES

ABBREVIATION

AH	AHEAD STATION
A.C.	ASPHALT CONCRETE
AZIM.	AZIMUTH
BK	BACK STATION
CL	CENTER LINE
cm	CENTIMETER
Def.	DEFLECTION
E	EXTERNAL DISTANCE OF CURVE
ELEV.	ELEVATION
e %	SUPER ELEVATION IN PERCENT
EQ.	EQUATION
HOR.	HORIZONTAL
H.W.L.	HIGH WATER LEVEL
l	GRADE
INV.	INVERT
kg.	KILOGRAM
Km.	KILOMETER
Km./hr.	KILOMETER PER HOUR
L	LENGTH
Lc.	LENGTH OF CIRCULAR CURVE
L.M.	LINEAR METER
L.V.C.	LENGTH OF VERTICAL CURVE
M.or m.	METER
mm.	MILLIMETER
M.S.L.	MEAN SEA LEVEL
m ²	SQUARE METER
m ³	CUBIC METER
NO.	NUMBER
P.B.C.	PRE-CAST BOX CULVERT
R	RADIUS OF CURVE
RDWY	ROADWAY
STA.	STATION
T	TANGENT LENGTH
t/m	TONNE PER SQUARE METER
VAR.	VARIABLE
VERT.	VERTICAL
V/kph	DESIGN SPEED IN KILOMETERS PER HOUR
∞	INFINITY
□	DITCH WITH CONCRETE COVER

GENERAL NOTES

1. STANDARD SPECIFICATION

A) ALL WORKS SHALL COMPLY WITH STANDARD SPECIFICATIONS, AND SPECIAL PROVISION TO THIS PROJECT.

2. DIMENSIONS

A) UNLESS OTHERWISE SPECIFIED, ALL DIMENSIONS WHICH INCLUDE STATIONINGS, DISTANCES BETWEEN CONTROL POINTS AND DIMENSIONS OF BOX CULVERTS ARE MEASURED IN METRIC.

3. STATIONING

A) THE ROAD STATIONINGS AND ELEMENTS OF CURVES ARE RELATIVE TO THE ULTIMATE CENTERLINE OF THE ROAD.
B) EQUATION OF STATIONS WHEN USED (BACK STATION / AHEAD STATION) ARE PROVIDED AT THE BEGINING OR END OF THE CURVE AND /OR AT FULL STATIONS.

4. HORIZONTAL CONTROL

A) BASIC TRAVERSE STATION WERE USED BY DIFFERENT COORDINATES SYSTEMS FOR EACH ROAD SECTIONS.

5. VERTICAL CONTROL

A) DATUM OF ALL ELEVATIONS IS MEAN SEA LEVEL.

6. ALIGNMENT

A) NO ALTERATION OR CHANGE IN ALIGNMENT AND GRADE SHALL BE MADE UNLESS EXISTING FIELD CONDITION SO WARRANT AND ONLY UPON WRITTEN ORDERS BY THE ENGINEERS AND APPROVED BY THE PROPER AUTHORITY CONCERNED.

7. OVERLAYS

A) TRANSITION BETWEEN VARYING THICKNESS OF OVERLAYS, OR TRANSITIONS TO STRUCTURES SHALL BE AT A MAXIMUM SLOPE OF 1%.

8. REMOVAL OF EXISTING STRUCTURES AND OBSTRUCTIONS

A) ALL WORKS SHALL COMPLY REQUIREMENTS AND CONDITIONS OF CONTRACT.
B) PORTIONS OF EXISTING UTILITIES, SUCH AS WATER MAINS, IRRIGATION CHANNELS, TELEPHONE POST AND TRUNK LINES, ETC. THAT MAY CAUSE OBSTRUCTION TO THE CONSTRUCTION OF THIS PROJECT SHALL BE RELOCATED BY THE ENTITY OR OWNER CONCERNED. EXTREME PRECAUTION SHALL BE EXERCISED BY THE CONTRACTOR NOT TO DAMAGE ANY SECTION OF THE EXISTING PUBLIC UTILITIES DURING CONSTRUCTION. ANY DAMAGE THEREOF SHALL BE ON THE ACCOUNT OF THE CONTRACTOR.

9. ROAD CONNECTIONS AND PRIVATE ENTRANCES

A) APPROACHES AND ROAD CONNECTIONS SHALL BE CONSTRUCTED BY THE CONTRACTOR AS SHOWN ON THE PLANS OR AS DIRECTED BY THE ENGINEER IN SUCH A MANNER TO INSURE SMOOTH CONNECTIONS AND RIDING QUALITY.
B) NO OPENING FOR DRIVEWAYS OR PRIVATE ENTRANCES SHALL BE ALLOWED EXCEPT WITH THE PRIOR APPROVAL FROM THE PROPER AUTHORITIES.

10. DRAINAGE STRUCTURES

A) EXACT LOCATIONS, SLOPES, OUTFALLS AND INVERT ELEVATIONS OF DRAINAGE STRUCTURES SHALL BE CHECKED IN THE FIELD BY THE ENGINEER, MINOR ADJUSTMENT MAY BE MADE BY THE APPROVAL OF THE ENGINEER TO SUIT ACTUAL FIELD CONDITIONS.
B) ANY REVISIONS, REMOVAL AND /OR RELAYING OF DRAINAGE STRUCTURES AS DIRECTED BY THE ENGINEER TO SUIT EXISTING FIELD CONDITIONS SHALL BE CONSIDERED AS SUBSIDIARY WORK PERTAINING TO OTHER CONTRACT ITEMS.

11. OPEN DITCHES

A) ALL DITCHES SHALL COMPLY WITH THE REQUIRED STANDARDS.
B) INVERT ELEVATIONS AND EXACT DIMENSIONS OF OPEN DITCHES MAY BE ADJUSTED IN THE FIELD AS DIRECTED BY THE ENGINEER.

2. TYPICAL CROSS SECTION

SCALE	TYPICAL CROSS SECTION	SHEET NO.
AS SHOWN	SECTION 1-1 (1)	2-1

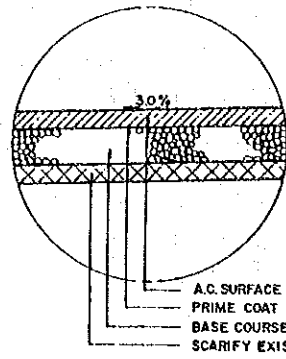

DETAIL A-1
SCALE 1:10

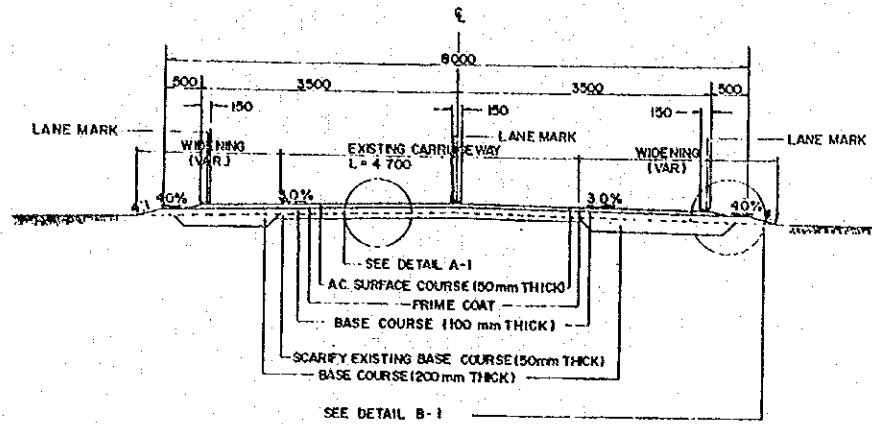

TYPICAL CROSS-SECTION NO. 1 (AC-1 TYPE PAVEMENT)
SCALE 1:50 M
STA. 0+000 TO STA. 0+123

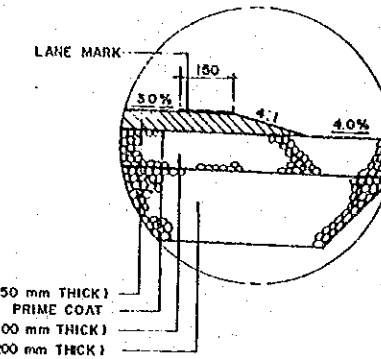

DETAIL B-1
SCALE 1:10

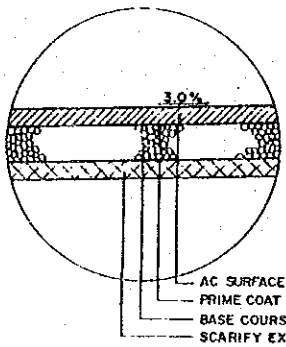

DETAIL A-2
SCALE 1:10

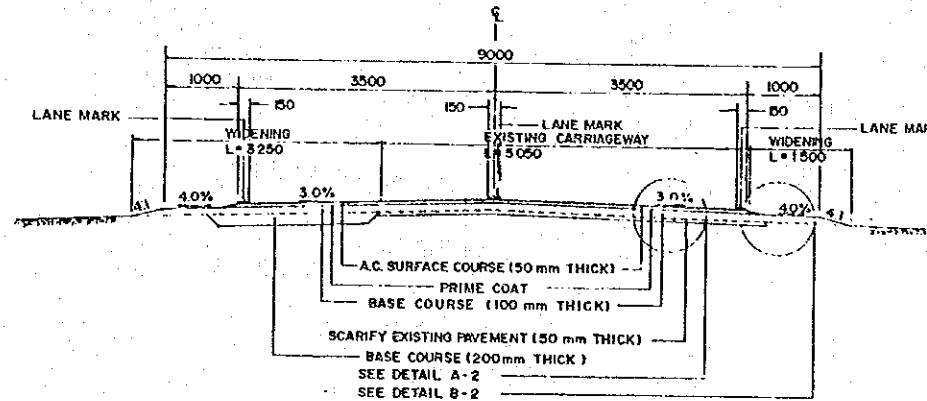

TYPICAL CROSS-SECTION NO. 2 (AC-2 TYPE PAVEMENT)
SCALE 1:50 M
STA. 0+123 TO STA. 2+768.50

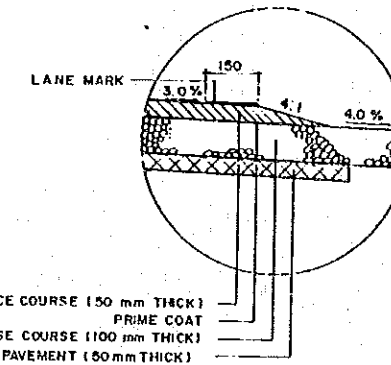

DETAIL B-2
SCALE 1:10

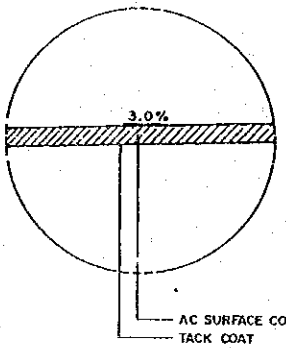

DETAIL A-3
SCALE 1:10

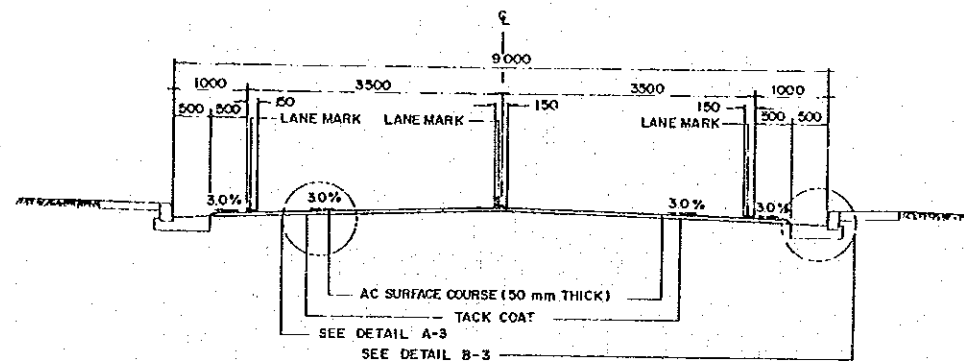

TYPICAL CROSS-SECTION NO. 3 (AC-4 TYPE PAVEMENT)
SCALE 1:50 M

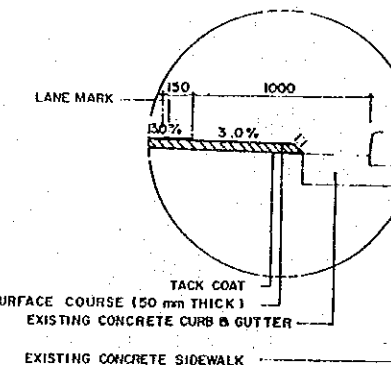

DETAIL B-3
SCALE 1:20

- STA. 2+768.5 TO STA. 2+886
- STA. 3+080.7 TO STA. 3+630
- STA. 3+993 TO STA. 4+013
- STA. 4+393 TO STA. 4+410
- STA. 4+790 TO STA. 4+810
- STA. 5+390 TO STA. 5+410

TYPICAL CROSS-SECTION, SECTION 1-1 (1)

SCALE	TYPICAL CROSS SECTION SECTION 1-1(2)	SHEET NO.
AS SHOWN		2-2

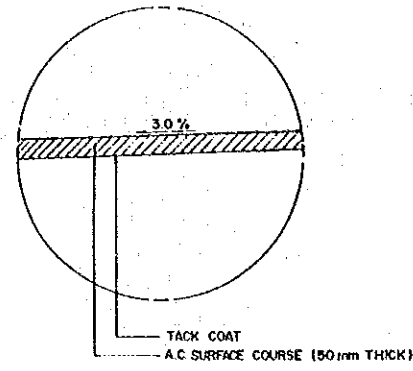

DETAIL A-4
SCALE 1:10

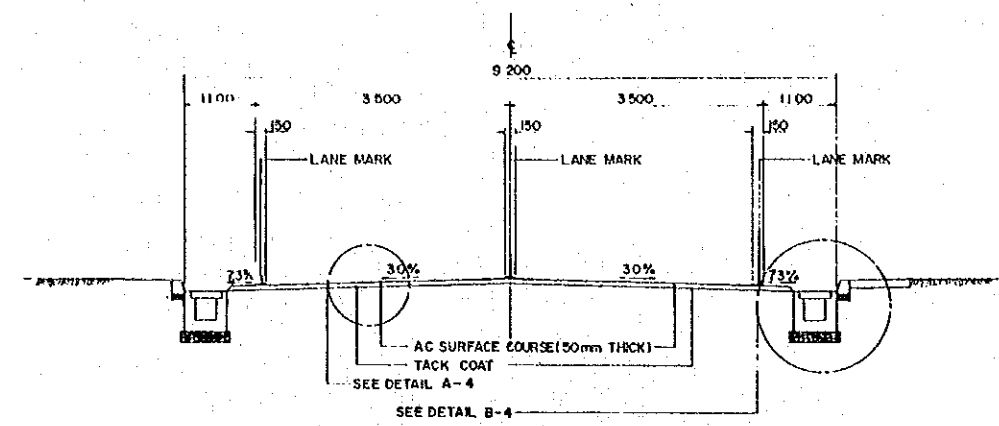

TYPICAL CROSS-SECTION NO. 4 (AC-4 TYPE PAVEMENT)
SCALE 1:50
STA. 2 + 886 TO STA. 3 + 080.700
STA. 3 + 630 TO STA. 3 + 993
STA. 4 + 013 TO STA. 4 + 393
STA. 4 + 410 TO STA. 4 + 790
STA. 4 + 810 TO STA. 5 + 072

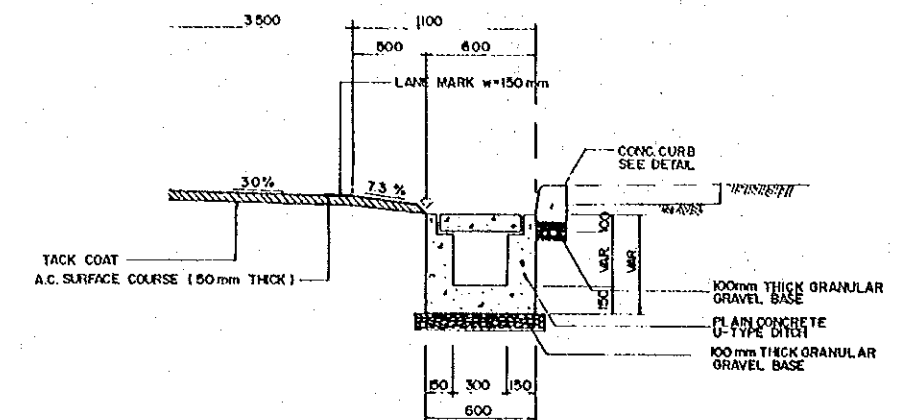

DETAIL B-4
SCALE 1:10

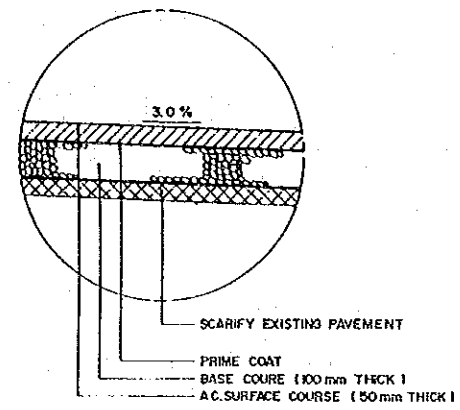

DETAIL A-6
SCALE 1:10

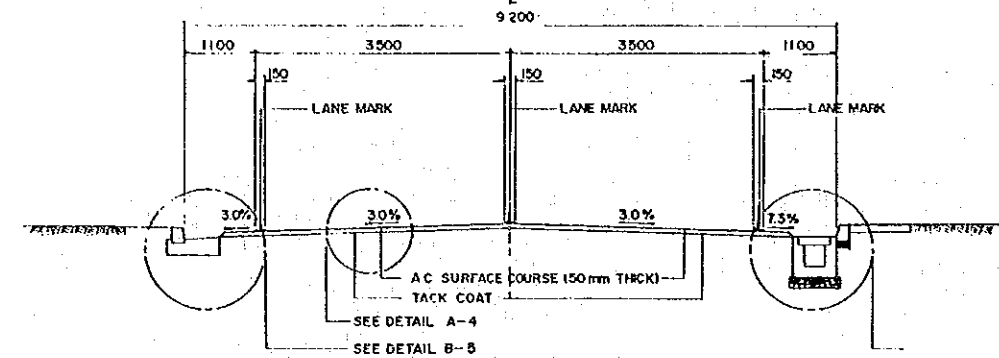

TYPICAL CROSS-SECTION NO. 5 (AC-3 TYPE PAVEMENT)
SCALE 1:50
STA. 5 + 072 TO STA. 5 + 390
STA. 5 + 410 TO STA. 5 + 829

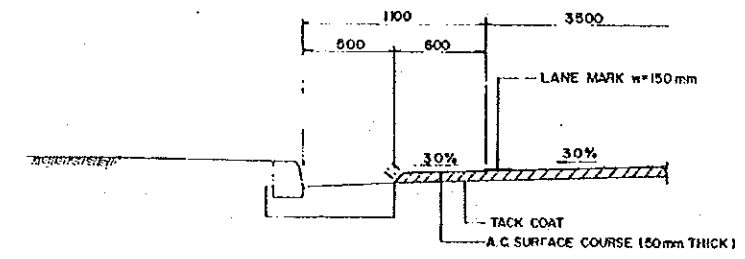

DETAIL B-5
SCALE 1:10

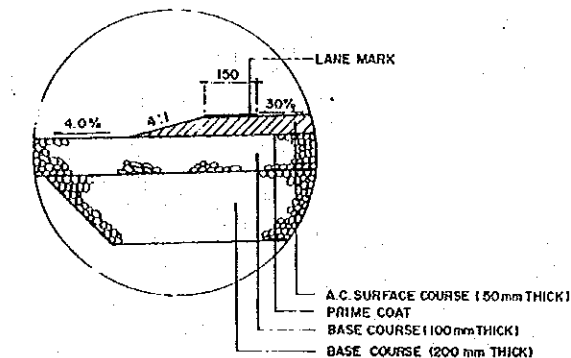

DETAIL B-6
SCALE 1:10

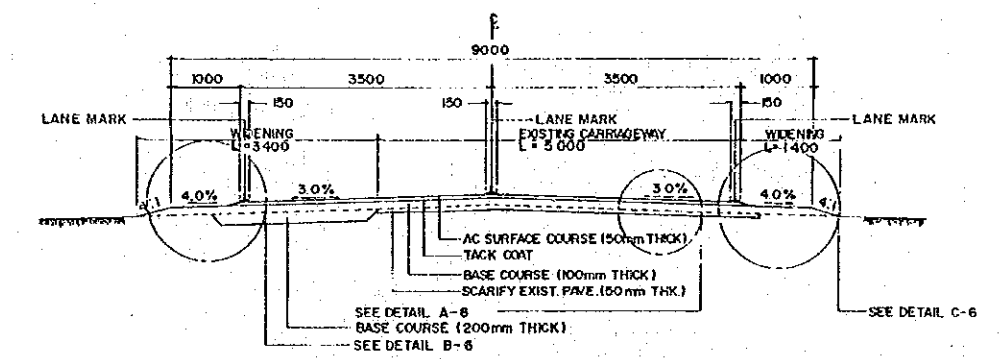

TYPICAL CROSS-SECTION NO. 6 (AC-2 TYPE PAVEMENT)
SCALE 1:50
STA. 5 + 829 TO STA. 7 + 407

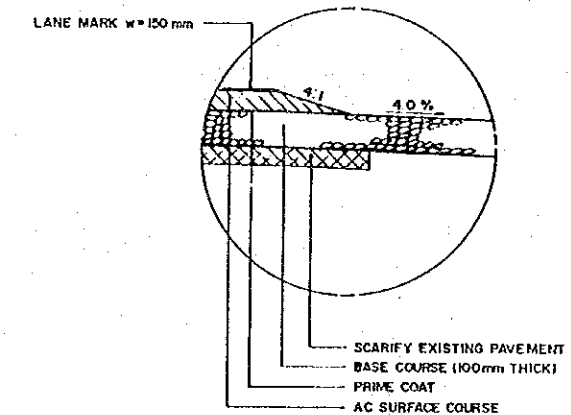

DETAIL C-6
SCALE 1:10

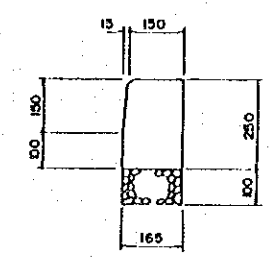

DETAIL OF CONCRETE CURB
SCALE 1:10

TYPICAL CROSS-SECTION, SECTION 1-1(2)

SCALE
AS SHOWN

TYPICAL CROSS SECTION
SECTION 1-1 (3)

SHEET NO.
2-3

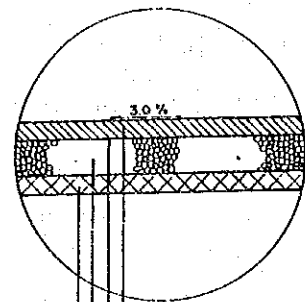

— A.C. SURFACE COURSE (50 mm THICK)
— PRIME COAT
— BASE COURSE (100 mm THICK)
— SCARIFY EXISTING BASE COURSE (50 mm THICK)

DETAIL A 7
SCALE 1:10

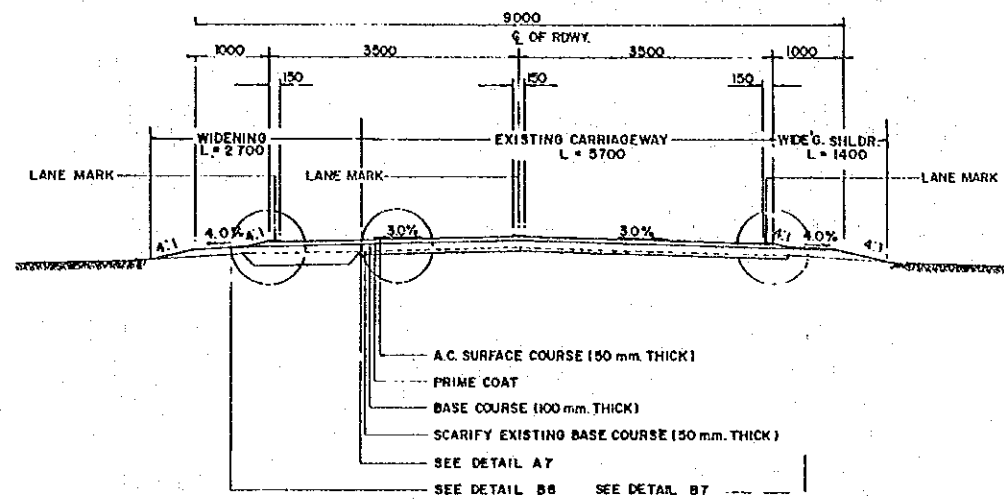

— A.C. SURFACE COURSE (50 mm THICK)
— PRIME COAT
— BASE COURSE (100 mm THICK)
— SCARIFY EXISTING BASE COURSE (50 mm THICK)
— SEE DETAIL A 7
— SEE DETAIL B 6 SEE DETAIL B 7

TYPICAL CROSS-SECTION NO. 7 (AC-1 TYPE PAVEMENT)
SCALE 1:50

STA. 7+407 TO STA. 7+532

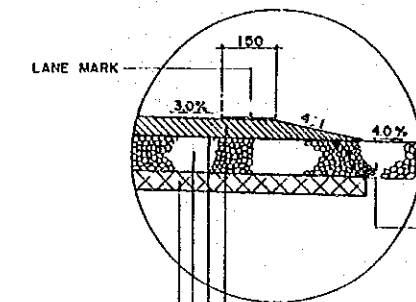

— AC SURFACE COURSE (50 mm THICK)
— PRIME COAT
— BASE COURSE (100 mm THICK)
— SCARIFY EXISTING BASE COURSE (50 mm THICK)

DETAIL B 7
SCALE 1:10

TYPICAL CROSS-SECTIONS, SECTION 1-1 (3)

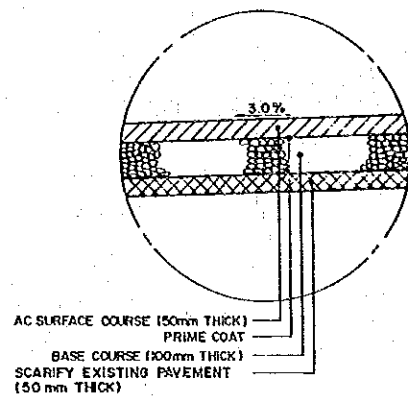

DETAIL A-8
SCALE 1:10

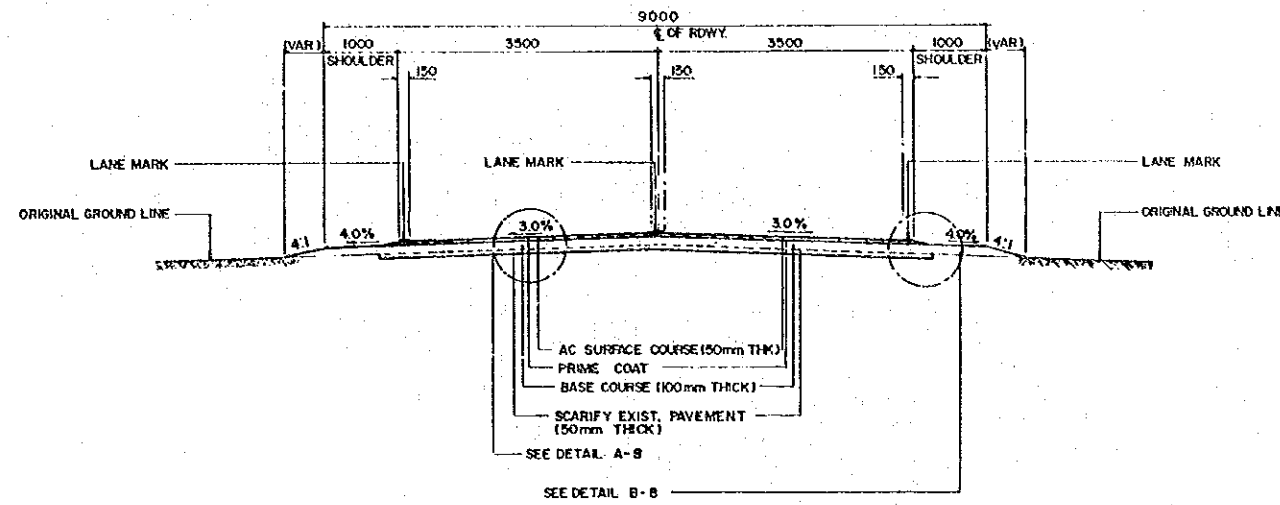

TYPICAL CROSS-SECTION NO.8 (AC-2 TYPE PAVEMENT)
SCALE 1:50 M

STA. 1+300 - STA. 5+540.000

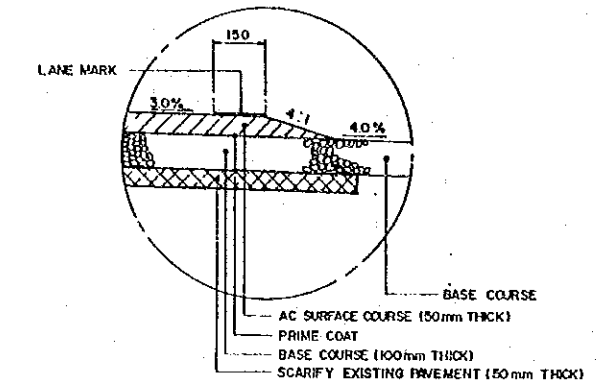

DETAIL B-8
SCALE 1:10

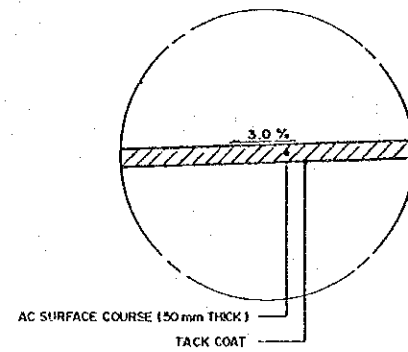

DETAIL A-9
SCALE 1:10

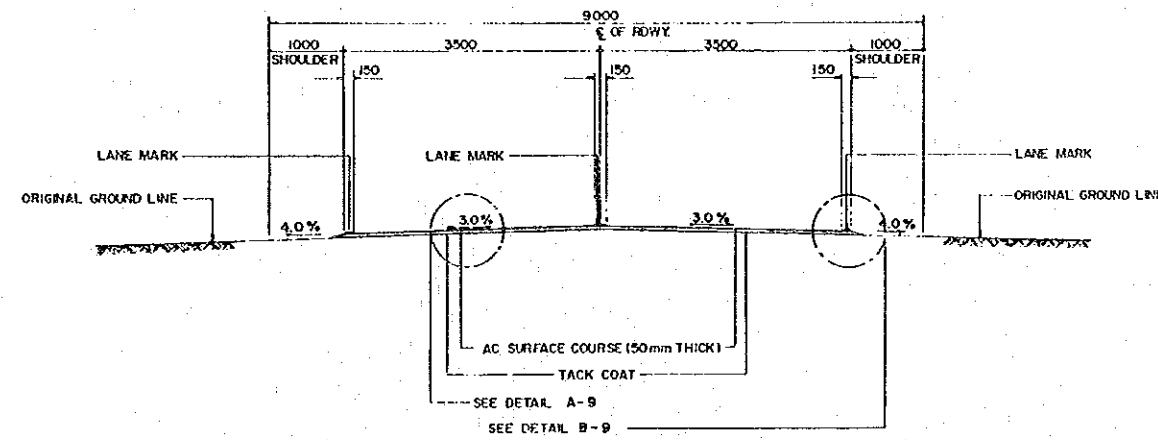

TYPICAL CROSS-SECTION NO.9 (AC-4 TYPE PAVEMENT)
SCALE 1:50 M

STA. 0+000 - STA. 1+300

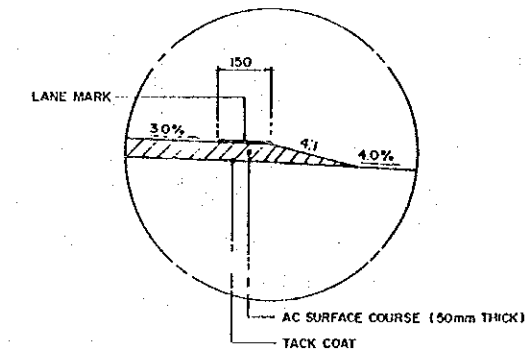

DETAIL B-9
SCALE 1:10

TYPICAL CROSS-SECTION, SECTION 1-2

SCALE	TYPICAL CROSS SECTION SECTION 7-1 (1)	SHEET NO.
AS SHOWN		2-5

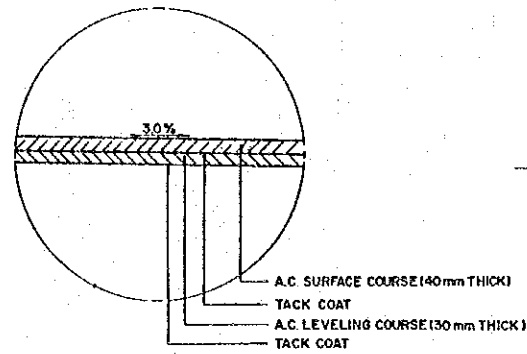

DETAIL A10
SCALE 1:10

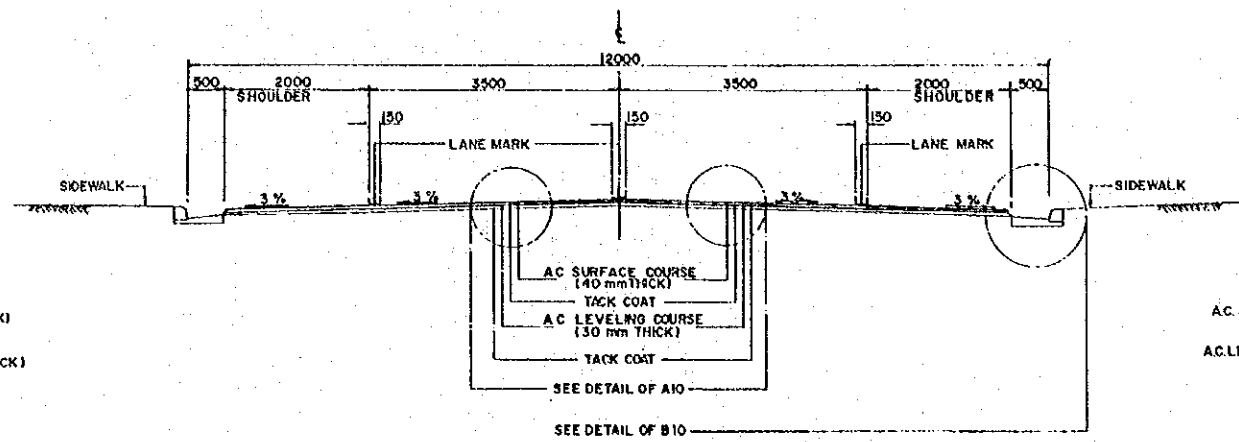

TYPICAL CROSS-SECTION NO. 10 (AC-3 TYPE PAVEMENT)
SCALE 1:50

NOTE: NOT APPLICABLE

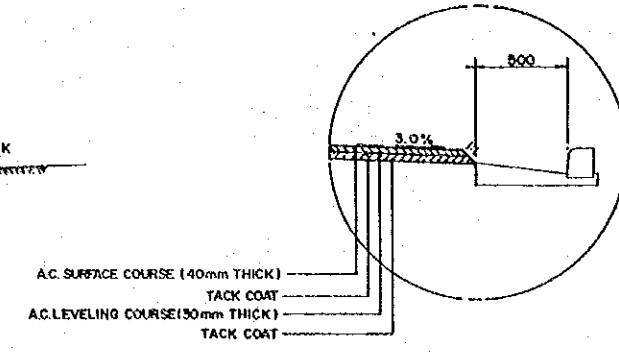

DETAIL B10
SCALE 1:10

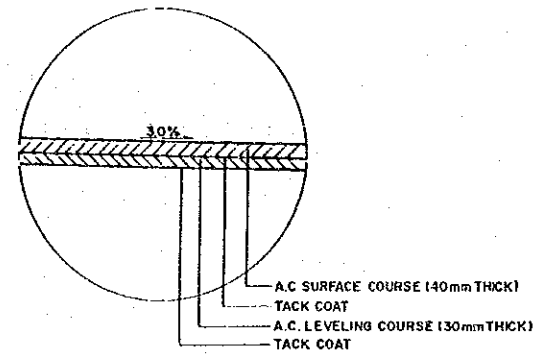

DETAIL A11
SCALE 1:10

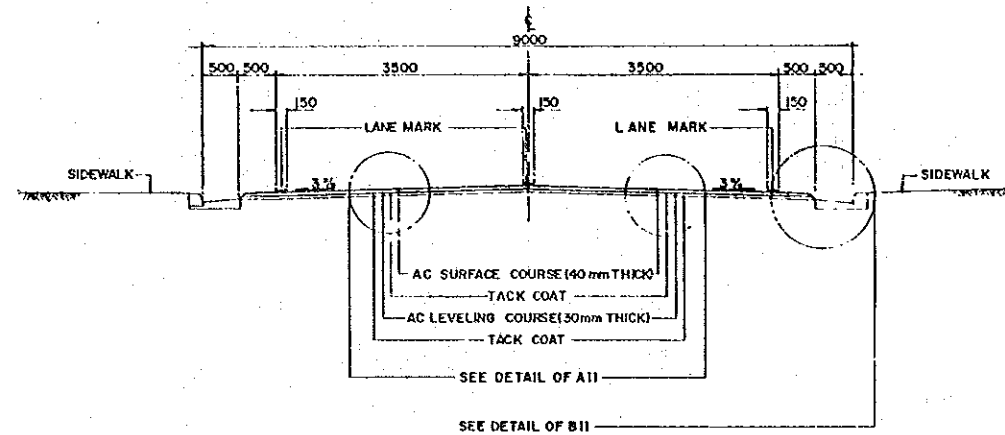

TYPICAL CROSS-SECTION NO. 11 (AC-3 TYPE PAVEMENT)
SCALE 1:50

STA. 0 + 555 TO STA. 0 + 655
STA. 1 + 383 TO STA. 1 + 483
STA. 2 + 490 TO STA. 2 + 594

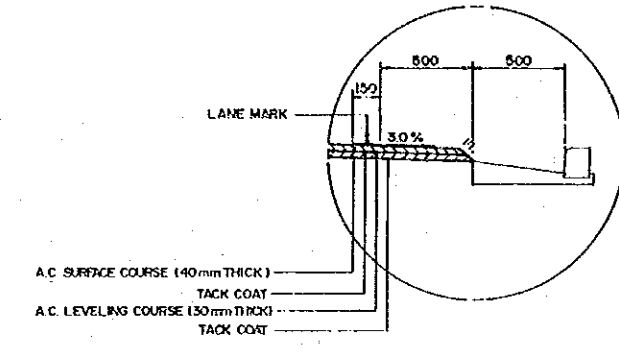

DETAIL B11
SCALE 1:10

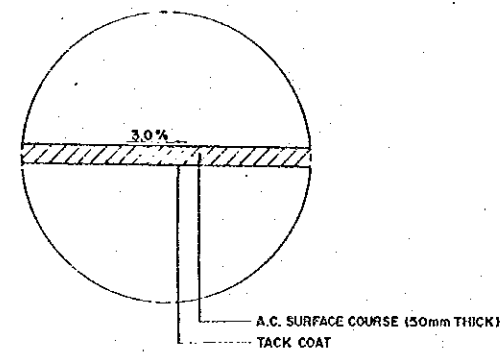

DETAIL A12
SCALE 1:10

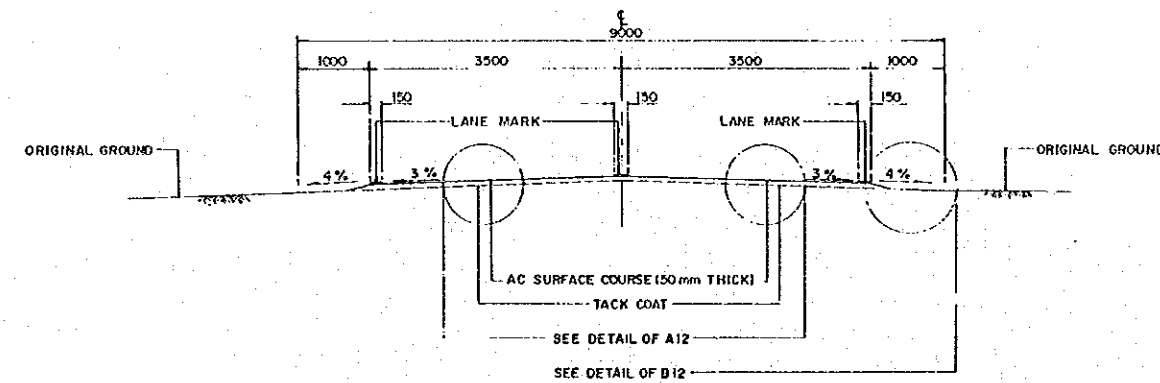

TYPICAL CROSS-SECTION NO. 12 (AC-4 TYPE PAVEMENT)
SCALE 1:50

STA. 0 + 655 TO STA. 1 + 383
STA. 1 + 483 TO STA. 2 + 490
STA. 2 + 594 TO STA. 4 + 400

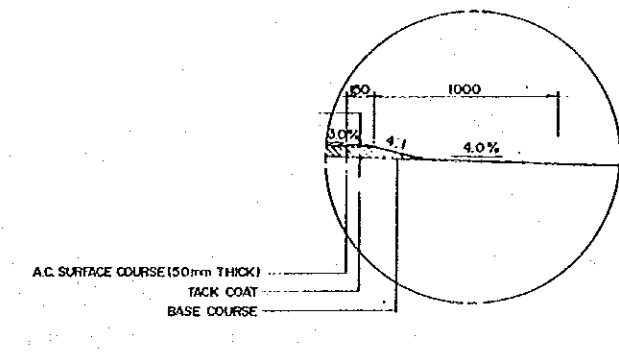

DETAIL B12
SCALE 1:10

TYPICAL CROSS-SECTIONS, SECTION 7-1 (1)

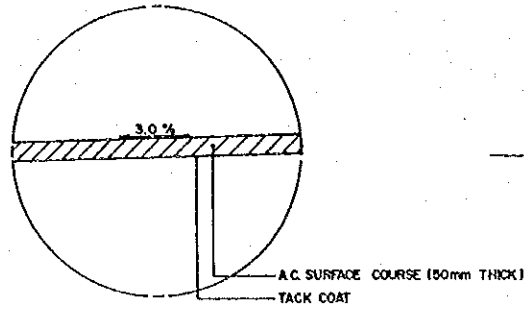

DETAIL A-13
SCALE 1:10

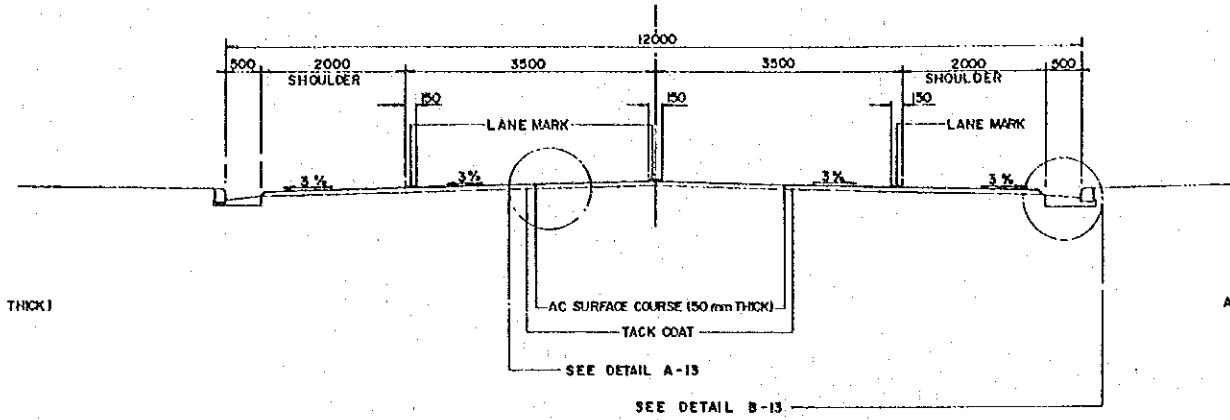

TYPICAL CROSS-SECTION NO. 13 (AC-4 TYPE PAVEMENT)
SCALE 1:50
STA. 0+014 TO STA. 0+386

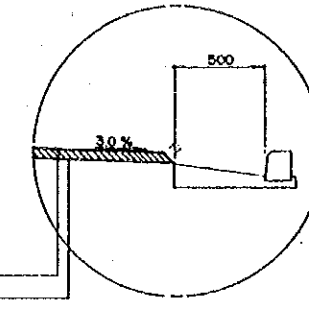

DETAIL B-13
SCALE 1:20

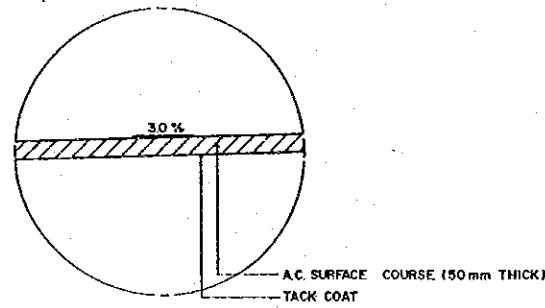

DETAIL A-14
SCALE 1:10

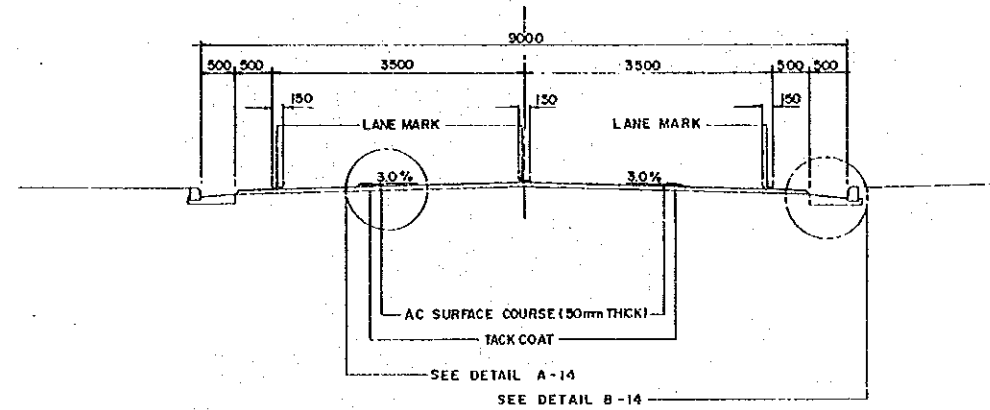

TYPICAL CROSS-SECTION NO. 14 (AC-4 TYPE PAVEMENT)
SCALE 1:50
STA. 0+386 TO STA. 0+555

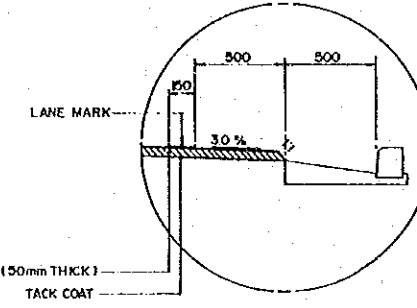

DETAIL B-14
SCALE 1:20

TYPICAL CROSS-SECTIONS, SECTION 7-1(2)

SCALE	TYPICAL CROSS SECTION SECTION 7-2, 7-3, 7-4	SHEET NO.
AS SHOWN		2-7

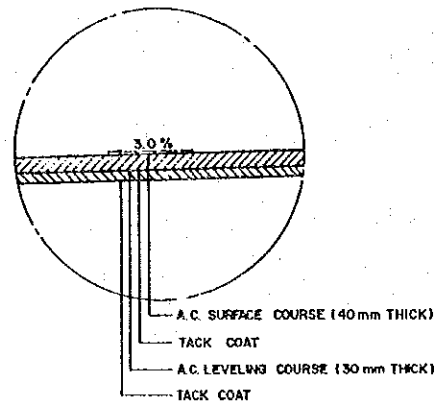

DETAIL A15
SCALE 1:10M

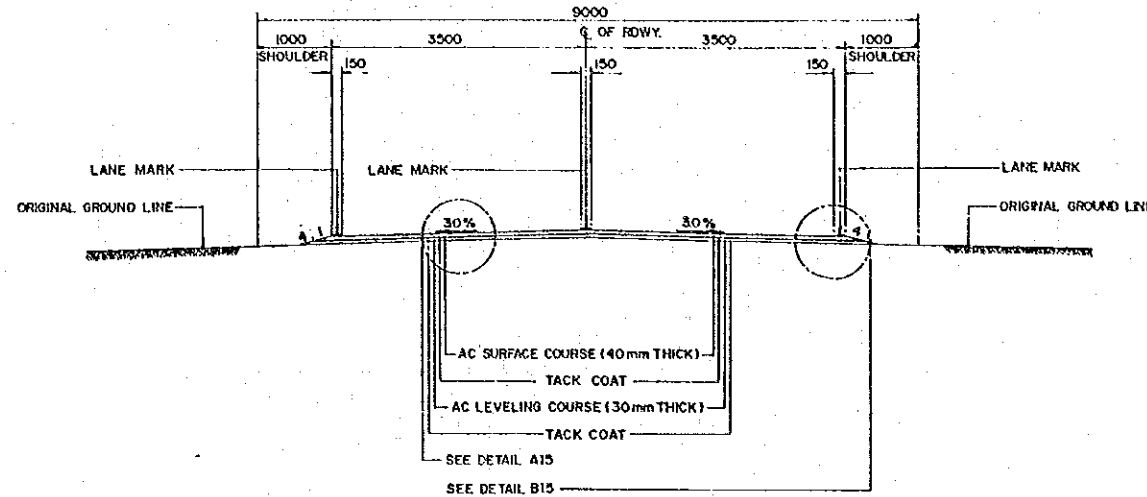

TYPICAL CROSS-SECTION NO. 15 (AC-3 TYPE PAVEMENT)
SCALE 1:50M

ROAD SECTION 7-2
STA. 7+620 TO STA. 7+669.300
ROAD SECTION 7-3
STA. 0+000 TO STA. 0+050
STA. 3+640.580 TO STA. 3+690.580
ROAD SECTION 7-4
STA. 3+690.580 TO STA. 3+740.580

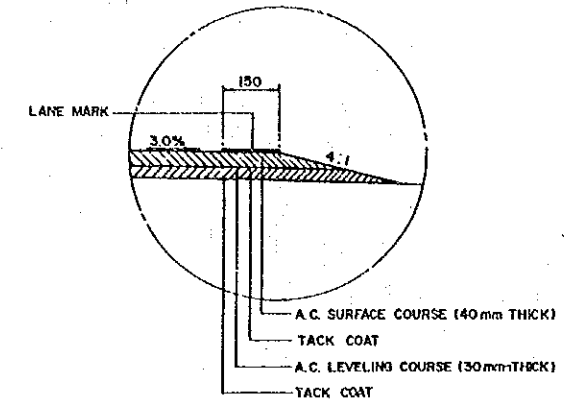

DETAIL B15
SCALE 1:10M

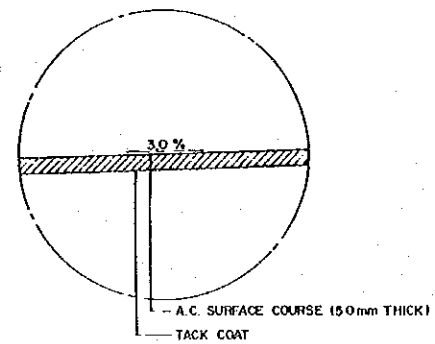

DETAIL A16
SCALE 1:10M

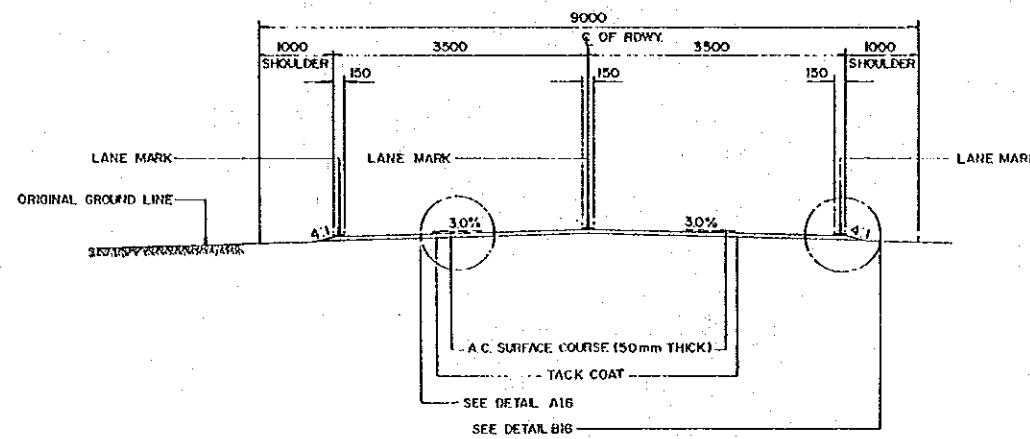

TYPICAL CROSS-SECTION NO. 16 (AC-4 TYPE PAVEMENT)
SCALE 1:50M

ROAD SECTION 7-2
STA. 1+400 TO STA. 7+103.830
STA. 0+000 TO STA. 7+620
ROAD SECTION 7-3
STA. 0+050 TO STA. 3+640.580
ROAD SECTION 7-4
STA. 3+740.580 TO STA. 6+310.379

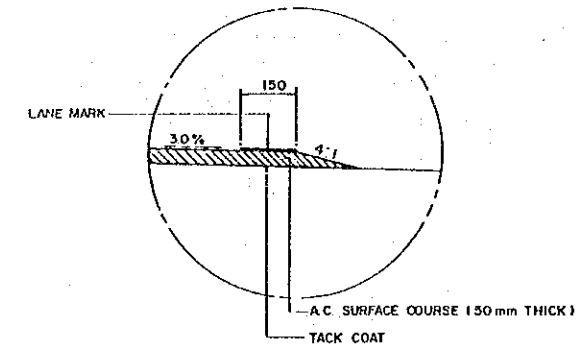

DETAIL B16
SCALE 1:10M

TYPICAL CROSS-SECTIONS, SECTION 7-2, 7-3, 7-4

PAVEMENT SCHEDULE

ROAD SECTION	STATION FROM — TO	TYPICAL CROSS-SECTION	TYPE OF PAVEMENT	LENGTH (m)	REMARKS
1 -- 1	STA. 0 + 000.000 — STA. 0 + 123.000	NO. 1	AC - 1	123.000	
	STA. 0 + 123.000 — STA. 2 + 768.500	NO. 2	AC - 2	2,643.791	EQ = 0.387 + 1.322
	STA. 2 + 768.500 — STA. 2 + 886.000	NO. 3	AC - 4	117.500	
	STA. 2 + 886.000 — STA. 3 + 080.700	NO. 4	AC - 4	194.700	
	STA. 3 + 080.700 — STA. 3 + 630.000	NO. 3	AC - 4	548.408	EQ = 0.892
	STA. 3 + 630.000 — STA. 3 + 993.000	NO. 4	AC - 4	363.000	
	STA. 3 + 993.000 — STA. 4 + 013.000	NO. 3	AC - 4	20.000	
	STA. 4 + 013.000 — STA. 4 + 393.000	NO. 4	AC - 4	380.000	
	STA. 4 + 393.000 — STA. 4 + 410.000	NO. 3	AC - 4	17.000	
	STA. 4 + 410.000 — STA. 4 + 790.000	NO. 4	AC - 4	380.000	
	STA. 4 + 790.000 — STA. 4 + 810.000	NO. 3	AC - 4	20.000	
	STA. 4 + 810.000 — STA. 5 + 072.000	NO. 4	AC - 4	262.000	
	STA. 5 + 072.000 — STA. 5 + 390.000	NO. 5	AC - 4	318.000	
	STA. 5 + 390.000 — STA. 5 + 410.000	NO. 3	AC - 4	20.000	
STA. 5 + 410.000 — STA. 5 + 829.000	NO. 5	AC - 4	419.000		
STA. 5 + 829.000 — STA. 7 + 407.000	NO. 6	AC - 2	1,578.000		
STA. 7 + 407.000 — STA. 7 + 532.000	NO. 7	AC - 1	125.000		
	SUB TOTAL			7,529.399	EQ = 2.601
1 -- 2	STA. 0 + 000.000 — STA. 1 + 300.000	NO. 9	AC - 4	1,298.870	EQ = 1.130
	STA. 1 + 300.000 — STA. 5 + 540.000	NO. 8	AC - 2	4,237.137	EQ = 2.403 + 0.460
	SUB TOTAL			5,536.007	EQ = 3.993
7 -- 1	STA. 0 + 014.000 — STA. 0 + 386.000	NO. 13	AC - 4	372.000	
	STA. 0 + 386.000 — STA. 0 + 555.000	NO. 14	AC - 4	169.000	
	STA. 0 + 555.000 — STA. 0 + 655.000	NO. 11	AC - 3	100.000	
	STA. 0 + 655.000 — STA. 1 + 383.000	NO. 12	AC - 4	728.000	
	STA. 1 + 383.000 — STA. 1 + 483.000	NO. 11	AC - 3	70.000	EXCEPTION = 30.000m.
	STA. 1 + 483.000 — STA. 2 + 490.000	NO. 12	AC - 4	1,007.000	
	STA. 2 + 490.000 — STA. 2 + 594.000	NO. 11	AC - 3	101.964	EQ = 2.036
	STA. 2 + 594.000 — STA. 4 + 400.000	NO. 12	AC - 4	1,806.000	
	SUB TOTAL			4,353.964	EQ = 2.036 + EXCEPTION = 30.000m.
7 -- 2	STA. 4 + 400.000 — STA. 7 + 103.830	NO. 16	AC - 4	2,703.830	
	STA. 0 + 000.000 — STA. 7 + 620.000	NO. 16	AC - 4	7,620.000	
	STA. 7 + 620.000 — STA. 7 + 669.300	NO. 15	AC - 3	49.300	
	SUB TOTAL			10,373.130	
7 -- 3	STA. 0 + 000.000 — STA. 0 + 050.000	NO. 15	AC - 3	50.000	
	STA. 0 + 050.000 — STA. 3 + 640.580	NO. 16	AC - 4	3,590.580	
	STA. 3 + 640.580 — STA. 3 + 690.580	NO. 15	AC - 3	50.000	
	SUB TOTAL			3,690.580	
7 -- 4	STA. 3 + 690.580 — STA. 3 + 740.580	NO. 15	AC - 3	50.000	
	STA. 3 + 740.580 — STA. 6 + 310.379	NO. 16	AC - 4	2,569.799	
	SUB TOTAL			2,619.799	TOTAL OF SECTION 7 : 21,037.473m
	GRAND TOTAL			34,102.879	EQ = 6.029 + EXCEPTION

3. PLAN AND PROFILE

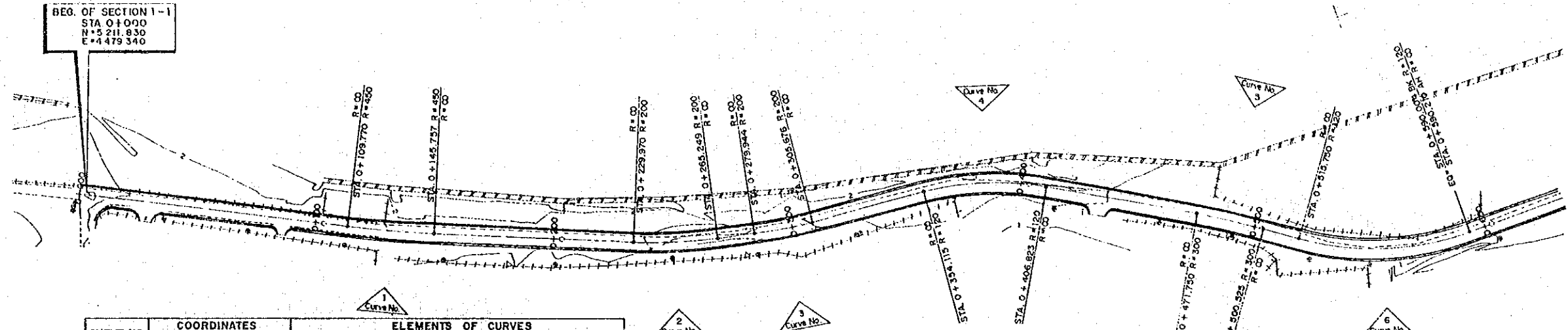
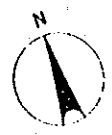

CURVE NO.	COORDINATES		ELEMENTS OF CURVES							
	NORTHING	EASTING	Def. Angle	Radius	T	Lc	E	s %	W	V(kph)
0	5211.830	4479.340	BEG. OF PROJECT							
1	5153.440	4592.991	04°34'55" L	450.000	18.003	35.987	0.360	As Existing	-	80
2	5107.342	4703.676	10°06'24" L	200.000	17.685	35.279	0.780	As Existing	-	80
3	5097.542	4747.866	07°22'18" L	200.000	12.884	25.732	0.410	As Existing	-	80
4	5089.660	4835.622	23°00'58" R	120.000	26.786	52.708	2.350	As Existing	-	80
5	5036.126	4927.239	05°29'44" R	300.000	14.398	28.775	0.300	As Existing	-	80
6	4996.365	4982.381	33°27'13" L	120.000	38.359	74.254	5.980	As Existing	-	80

NOTE : COORDINATES SYSTEM ON THIS ROAD SECTION (1-1) USED LOCAL SYSTEM THIS SYSTEM HAS NO RELATIONSHIP TO OTHER ROAD SECTION.

ELEVATION	STATION											
	0+000	0+100	0+145.757	0+200	0+229.970	0+279.944	0+300	0+354.115	0+400	0+471.750	0+500	0+589.824
PROPOSED HEIGHT	1.710	1.950	1.910	1.850	1.860	1.690	1.740	1.730	1.780	1.860	1.480	1.350
EXISTING HEIGHT	1.560	1.760	1.700	1.810	1.540	1.590	1.580	1.520	1.630	1.710	1.330	1.400
HORIZONTAL CURVATURE		R=∞ L=109.770m	R=450m L=35.990m	R=∞ L=84.213m	R=200m L=35.200m	R=∞ L=14.699m	R=200m L=23.732m	R=∞ L=48.439m	R=120m L=52.710m	R=∞ L=65.678m	R=300m L=28.775m	R=∞ L=15.045m
VERTICAL CURVATURE		A : EXISTING										
SUPERELEVATION		A : EXISTING										
ACCUMULATED DISTANCE	0.000	100.000	145.757	200.000	229.970	265.249	279.944	300.000	354.115	399.920	400.000	471.750

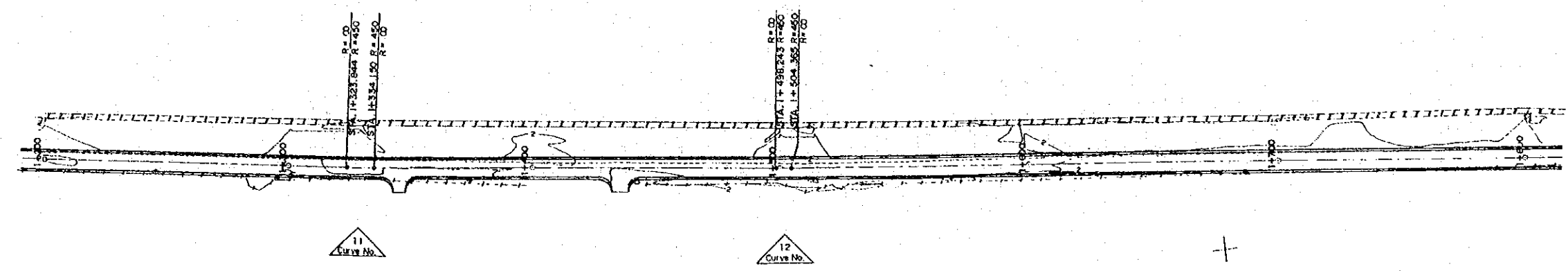

CURVE NO.	COORDINATES		ELEMENTS OF CURVES						
	NORTHING	EASTING	Def. Angle	Radius	T	Lc	E	e%	V(kph)
11	4 974.808	5 755.408	01° 48' 39" L	450.000	7.112	14.222	0.060	As Existing	80
12	4 953.993	5 926.455	00° 46' 46" L	450.000	3.061	6.122	0.010	As Existing	80

ELEVATION	STATION										
	1+200	1+300	1+323.844	1+334.150	1+400	1+498.243	1+500	1+504.365	1+600	1+700	1+800
5.000											
0.000											
-5.000											
PROPOSED HEIGHT	2.200	2.220	2.160	2.160	2.330	2.200	2.210	2.230	2.280	2.070	2.120
EXISTING HEIGHT	2.050	2.070	2.000	2.010	2.180	2.080	2.080	2.010	2.120	1.920	1.970
HORIZONTAL CURVATURE			R=450m L=13.222m		R=∞ L=164.093m		R=450m L=6.122m		R=∞ L=341.818m		
VERTICAL CURVATURE	A: EXISTING										
SUPERELEVATION	A: EXISTING										
ACCUMULATED DISTANCE	1195.613	1596.613	1623.457	1633.763	1699.613	1877.856	1879.613	1903.974	1919.413	2096.613	2176.613

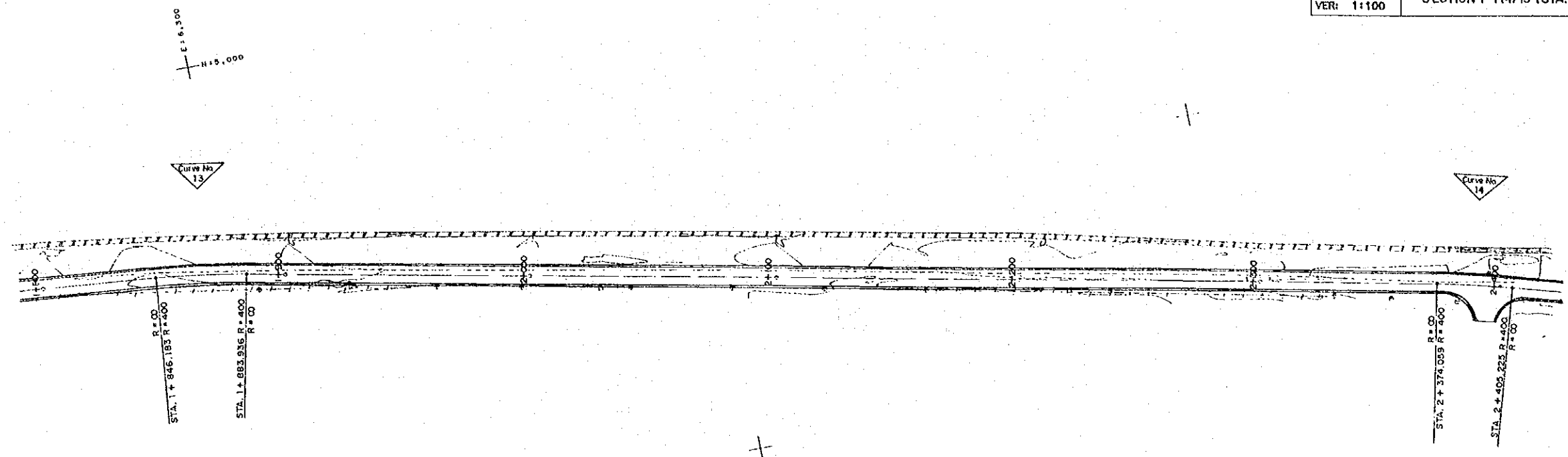
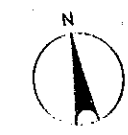

CURVE NO.	COORDINATES		ELEMENTS OF CURVES							
	NORTHING	EASTING	Def. Angle	Radius	T	Lc	E	a %	w	V(kph)
13	4 914 .966	6 288.125	05°27'24"R	400.000	19.062	38.035	0.450	AS EXISTING	-	80
14	4 809 .340	6 801.966	04°27'51"R	400.000	15.591	31.166	0.300	AS EXISTING	-	80

ELEVATION	STATION	PROPOSED HEIGHT	EXISTING HEIGHT	HORIZONTAL CURVATURE	VERTICAL CURVATURE	SUPERELEVATION	ACCUMULATED DISTANCE
3.000	1+800	2.120	1.970				-1759.613
0.000	1+846.183	2.120	1.990	R = 400 m L = 37.753 m			-1825.073
	1+883.936	2.120	1.970				-1845.795
	1+900	2.140	1.990				-1859.433
	2+000	2.370	1.960				-1899.613
	2+100	2.360	2.200	R = 00 L = 490.123 m	A = EXISTING		-2088.613
	2+200	2.200	2.050				-2141.303
	2+300	2.210	2.050				-2192.613
	2+374.039	2.290	2.100	R = 400 m L = 31.166 m			-2259.613
	2+400	2.260	2.110				-2339.613

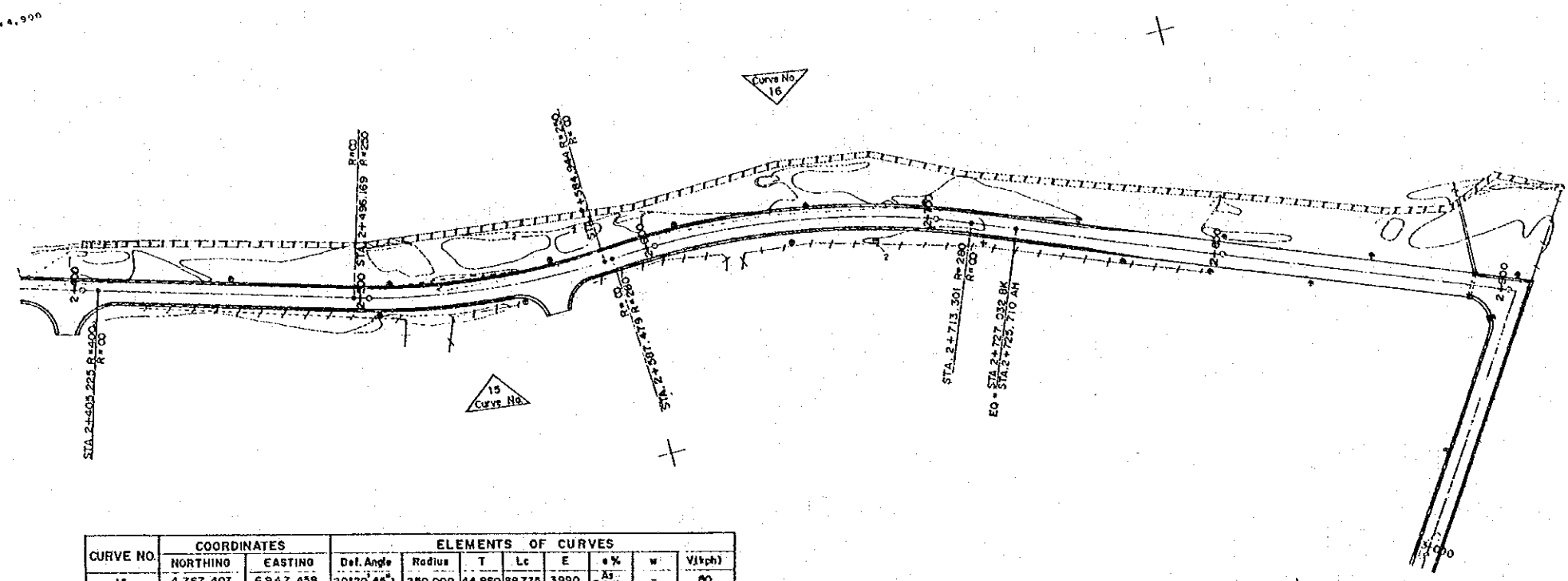
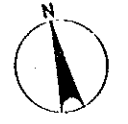

CURVE NO.	COORDINATES		ELEMENTS OF CURVES							
	NORTHING	EASTING	Def. Angle	Radius	T	Lc	E	e %	w	V(1/4)ph
15	4 767.407	6 947.458	20°20'45" L	250.000	44.860	88.775	3990	As Existing	-	80
16	4 775.693	7 058.535	25°44'48" R	280.000	63.991	125.822	7220	As Existing	-	80

ELEVATION	STATION																							
	2+400	2+405.225	2+496.169	2+500	2+584.944	2+600	2+607.479	2+700	2+713.301	2+800	2+866.500	2+903.470	3+000											
5.000																								
0.000																								
PROPOSED HEIGHT	2.110	2.260	2.140	2.290	2.180	2.330	2.110	2.260	2.220	2.370	2.100	2.250	2.000											
EXISTING HEIGHT	2.120	2.270	2.150	2.300	2.190	2.340	2.120	2.270	2.230	2.380	2.110	2.260	2.010											
HORIZONTAL CURVATURE	R = ∞ L = 90.944		R = ∞ L = 88.775 m R = 250 m				R = 250 m L = 125.822 m				R = ∞ L = 191.491		R = ∞ L = 177.230											
VERTICAL CURVATURE	A: EXISTING																							
SUPERELEVATION	A: EXISTING																							
ACCUMULATED DISTANCE	2599.613	2400.488	2430.493	2495.782	2495.653	2506.298	2521.513	2534.493	2563.173	2599.613	2654.123	2651.623	2666.063	2692.843	2695.673	2712.914	2725.323	2751.991	2766.981	2798.291	2864.791	2898.291	2901.701	2898.291

BASIC DESIGN STUDY ON THE PROJECT FOR ROAD IMPROVEMENT WORKS IN TONGATAPU IN THE KINGDOM OF TONGA

SCALE
HORI: 1:1000
VER: 1:100

PLAN AND PROFILE
SECTION 1-1 (6/13) STA. 3+000 - STA. 3+600

SHEET NO.
3-6

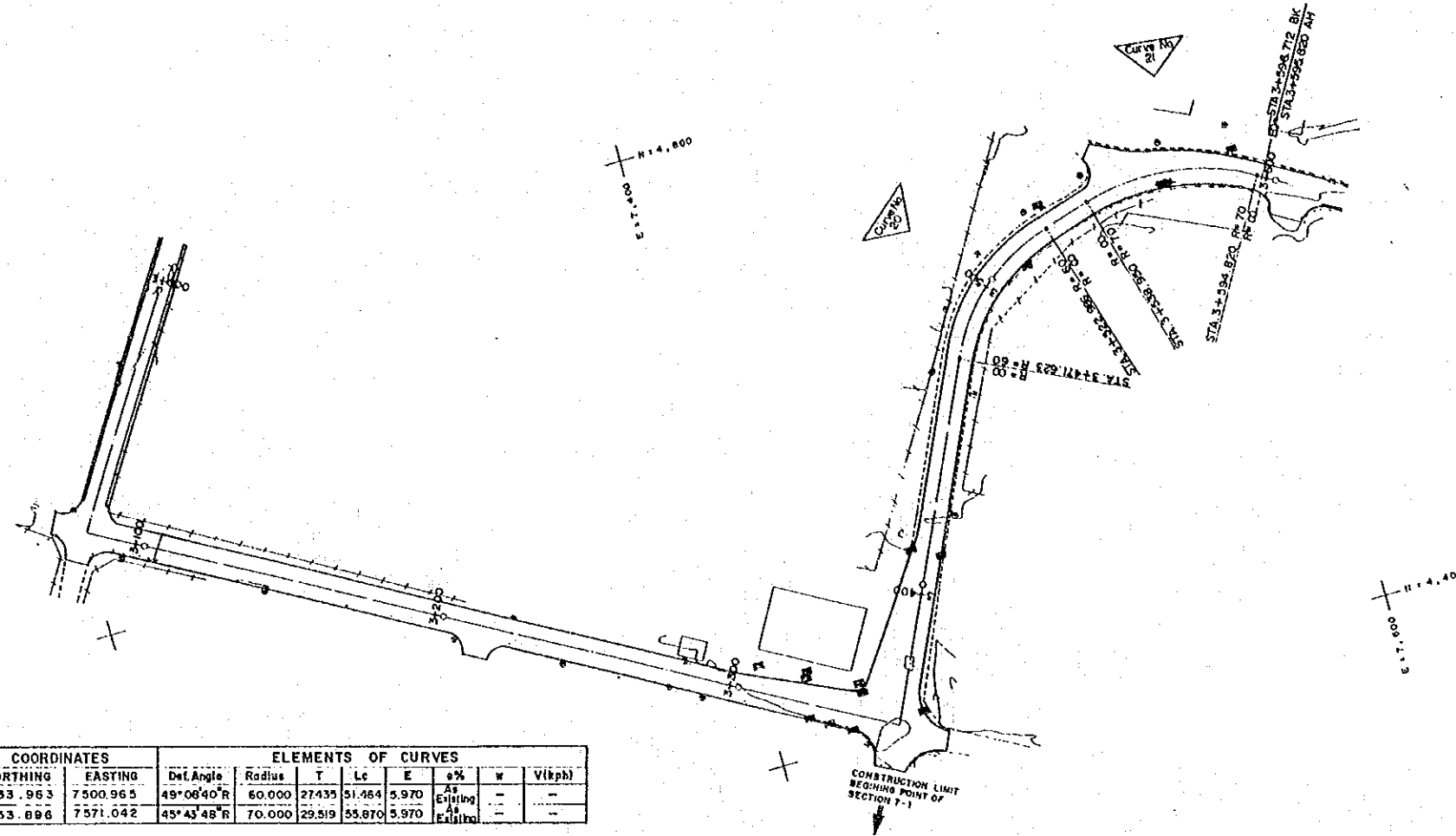

CURVE NO.	COORDINATES		ELEMENTS OF CURVES								
	NORTHING	EASTING	Def. Angle	Radius	T	Lc	E	e%	w	V(kph)	
20	4 533.963	7 500.965	49°08'40" R	60.000	27.435	51.464	5.970	As Existing	---	---	---
21	4 553.896	7 571.042	45°43'48" R	70.000	29.519	55.870	5.970	As Existing	---	---	---

ELEVATION	STATION																				
	3+000	3+080.700	3+100	3+200	3+300	3+353.440	3+373.440	3+400	3+471.623	3+500	3+538.990	3+594.820	3+600								
5.000																					
0.000																					
-5.000																					
PROPOSED HEIGHT	2.050	2.200	2.060	1.820	1.860	1.890	1.860	1.820	1.840	1.840	1.720	1.750	1.710								
EXISTING HEIGHT	2.000	2.150	2.010	1.770	1.810	1.840	1.810	1.770	1.790	1.790	1.670	1.690	1.660								
HORIZONTAL CURVATURE	R=∞ L=177.230 m			R=∞ L=272.740 m			R=∞ L=118.183 m		R=60 m L=31.363 m		R=∞ L=15.964		R=70 m L=55.870 m								
VERTICAL CURVATURE	As EXISTING																				
SUPERELEVATION	As EXISTING																				
ACCUMULATED DISTANCE	2598.291	3068.991	3078.991	3098.291	3298.291	3351.731	3371.731	3398.291	3463.831	3483.914	3481.071	3482.941	3498.291	3505.021	3521.277	3537.241	3545.961	3563.861	3577.681	3593.111	3597.399

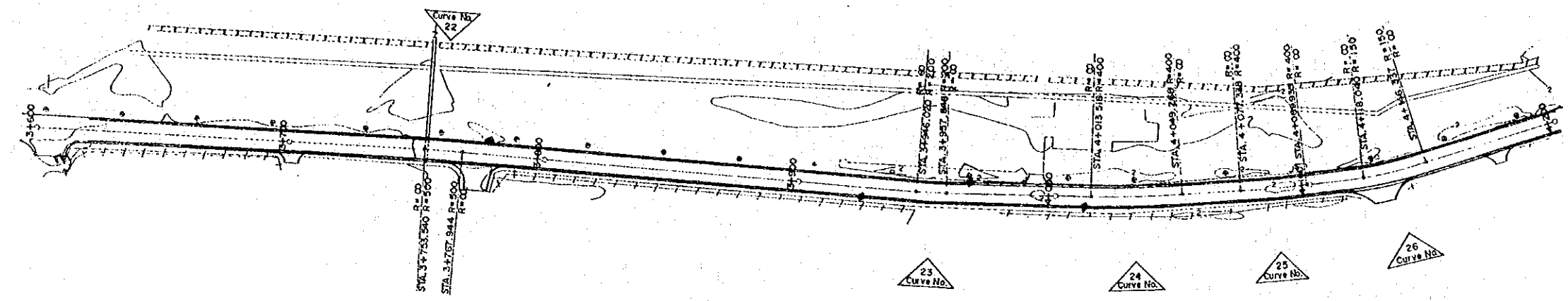

CURVE NO.	COORDINATES		ELEMENTS OF CURVES							
	NORTHING	EASTING	Def. Angle	Radius	T	Lc	E	e%	w	V(kph)
22	4 456.168	7 741.324	01°39' 01" R	500.000	7.201	14.401	0.050	As Existing	---	80
23	4 356.264	7 904.336	03°23' 13" L	200.000	5.913	11.823	0.090	As Existing	---	80
24	4 318.814	7 974.428	05°07' 16" L	400.000	17.886	35.752	0.400	As Existing	---	80
25	4 296.644	8 026.671	03°09' 33" L	400.000	10.797	21.590	0.150	As Existing	---	80
26	4 281.632	8 068.136	10°48' 31" L	150.000	14.191	28.297	0.670	As Existing	---	80

ELEVATION	5.000		0.000																																																	
STATION	3+600		3+700		3+767.944		3+800		3+900		3+946.020		4+000		4+049.268		4+077.350		4+118.040		4+146.337		4+200																													
PROPOSED HEIGHT	-1.710		-1.690		-1.580		-1.700		-1.910		-1.940		-2.030		-1.930		-1.960		-1.940		-1.910		-2.020																													
EXISTING HEIGHT	-1.660		-1.450		-1.530		-1.660		-1.860		-1.930		-1.890		-1.860		-1.910		-1.890		-1.860		-1.970																													
HORIZONTAL CURVATURE	R = ∞																R = ∞		L = 178.080		R = ∞		L = 111.824		R = ∞		L = 55.670		R = 400		L = 32.730		R = ∞		L = 28.070		R = 400		L = 21.332		R = ∞		L = 19.110		R = 150		L = 28.297		R = ∞		L = 88.190	
VERTICAL CURVATURE	A : EXISTING																																																			
SUPERELEVATION	A : EXISTING																																																			
ACCUMULATED DISTANCE	-3597.399		-3617.399		-3697.399		-3750.399		-3765.399		-3797.399		-3897.399		-3943.322		-3985.217		-3997.399		-4010.917		-4046.657		-4079.737		-4096.239		-4097.399		-4115.439		-4143.756		-427.399																	

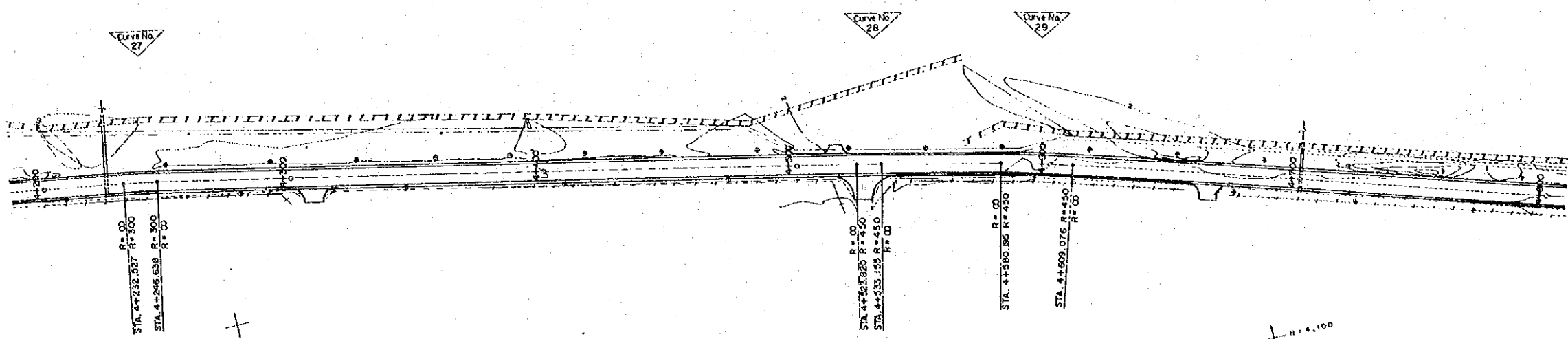
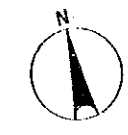

CURVE NO.	COORDINATES		ELEMENTS OF CURVES							
	NORTHING	EASTING	Def. Angle	Radius	T	Lc	E	e%	w	V(kph)
27	4 264.651	8 174.233	02° 41' 42" R	300.000	7.057	14.111	0.080	As Existing	-	80
28	4 205.627	8 457.052	01° 11' 19" R	450.000	4.668	9.335	0.022	As Existing	-	80
29	4 190.772	8 521.515	03° 40' 58" R	450.000	14.445	28.891	0.230	As Existing	-	80

ELEVATION	STATION	PROPOSED HEIGHT	EXISTING HEIGHT	HORIZONTAL CURVATURE	VERTICAL CURVATURE	SUPERELEVATION	ACCUMULATED DISTANCE
5.000	4+200	2.020	1.970				4197.399
0.000	4+232.527	1.900	1.850	R=300m L=86.190m			4229.919
	4+246.638	1.850	1.840	R=∞ L=277.182m			4241.037
	4+300	1.950	1.900				4297.399
	4+400	2.040	1.950				4497.399
	4+500	1.940	1.850				4521.219
	4+523.820	1.870	1.820	R=450m L=9.335m			4530.254
	4+533.155	1.860	1.810				4572.994
	4+550.195	1.580	1.530				4597.399
	4+609.076	1.570	1.520	R=450m L=28.891m			4606.075
	4+700	1.510	1.460				4657.399
	4+800	1.450	1.440	R=∞ L=545.350m			4797.399

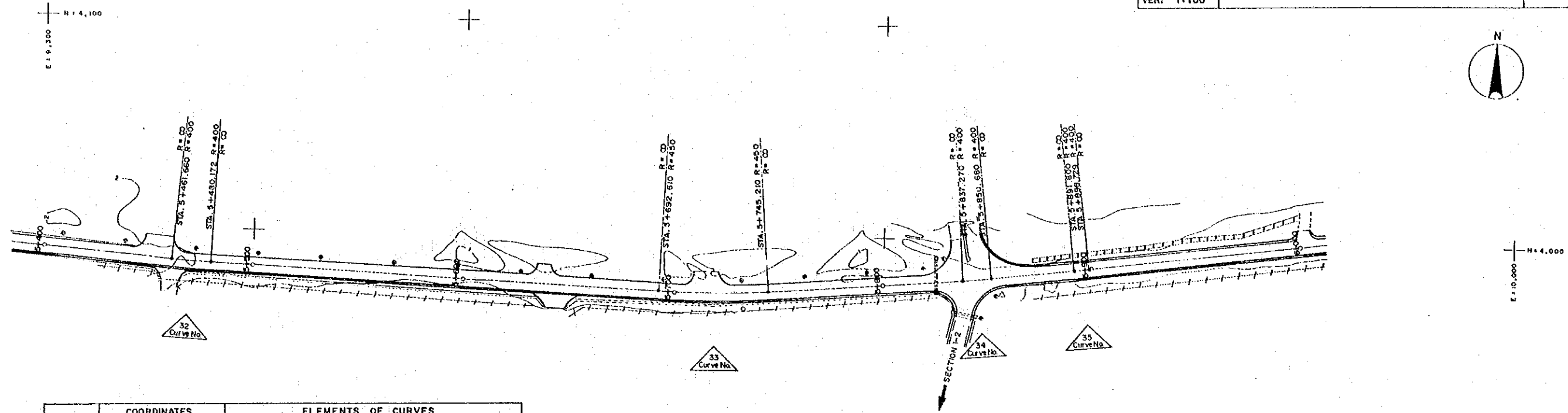

CURVE NO.	COORDINATES		ELEMENTS OF CURVES									
	NORTHING	EASTING	Def. Angle	Radius	T	Lc	E	e %	w	V(kph)		
32	3 984.374	9 370.069	02°39'06" L	400.000	9.258	18.512	0.110	Existing	-	80		
33	3 972.557	9 617.813	06°41'50" L	450.000	26.330	52.600	0.770	Existing	-	80		
34	3 981.210	9 742.610	01°55'15" L	400.000	6.706	13.410	0.060	Existing	-	80		
35	3 986.471	9 793.629	00°59'33" L	400.000	3.465	6.929	0.020	Existing	-	80		

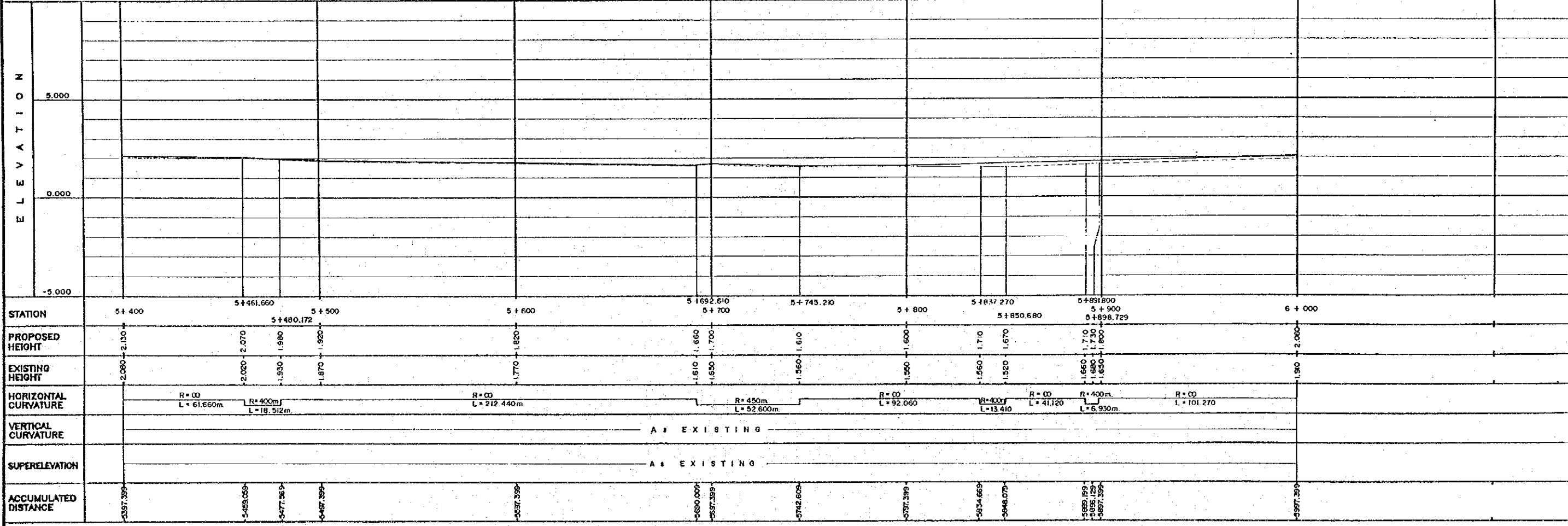

STATION	5+400	5+461.660	5+480.172	5+500	5+600	5+692.610	5+700	5+745.210	5+800	5+837.270	5+850.680	5+891.800	5+900	5+898.729	6+000			
PROPOSED HEIGHT	2.130	2.070	1.980	1.920	1.820	1.660	1.700	1.610	1.500	1.710	1.670	1.710	1.730	1.800	2.060			
EXISTING HEIGHT	2.080	2.020	1.930	1.870	1.770	1.610	1.650	1.560	1.450	1.660	1.620	1.660	1.680	1.750	1.910			
HORIZONTAL CURVATURE	R=∞ L=61.660m		R=∞ L=18.512m		R=∞ L=212.440m		R=450m L=52.600m		R=∞ L=92.060m		R=∞ L=13.410m		R=∞ L=41.120m		R=∞ L=6.930m		R=∞ L=101.270m	
VERTICAL CURVATURE	A = EXISTING																	
SUPERELEVATION	A = EXISTING																	
ACCUMULATED DISTANCE	0.000	61.660	80.172	141.732	354.172	566.612	577.399	621.819	713.819	805.819	849.879	891.800	900.000	898.729	999.729			

BASIC DESIGN STUDY ON THE PROJECT FOR
ROAD IMPROVEMENT WORKS IN TONGATAPU IN THE KINGDOM OF TONGA

SCALE
HOR: 1:1000
VER: 1:100

PLAN AND PROFILE
SECTION I-(11/13) STA. 6+000 - STA. 6+600

SHEET NO.
3-11

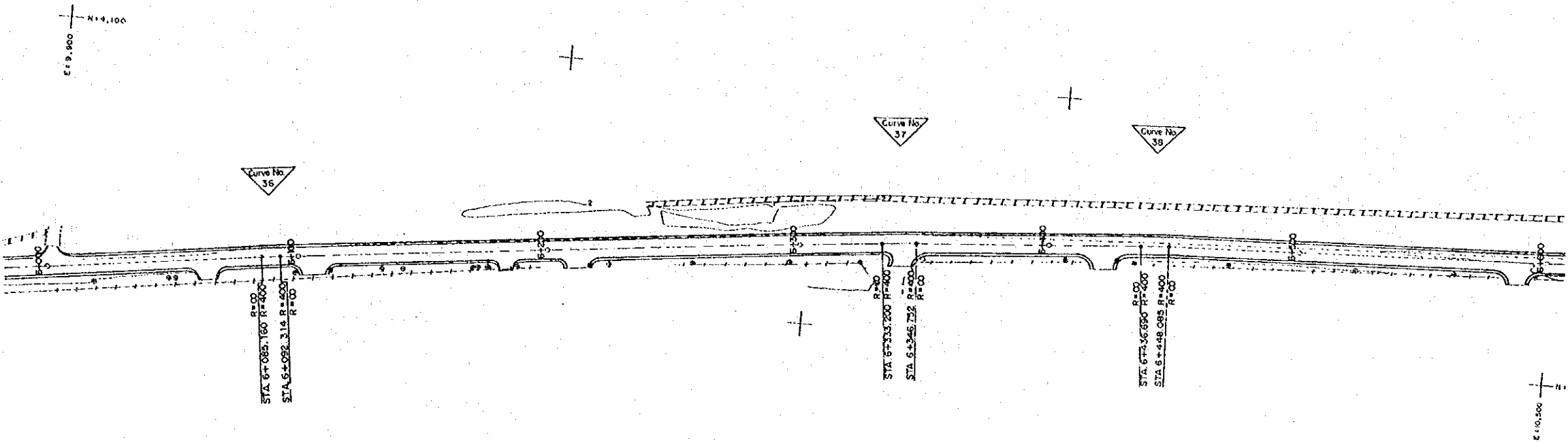

CURVE NO.	COORDINATES		ELEMENTS OF CURVES							
	NORTHING	EASTING	Def. Angle	Radius	T	Lc	E	e%	w	V(kph)
35	4 009.646	9 985.709	01° 01' 26" R	400.000	3.576	7.152	0.020	As Existing	-	80
37	4 035.276	10 235.637	01° 56' 29" R	400.000	6.777	13.553	0.060	As Existing	-	80
38	4 042.288	10 337.810	01° 37' 56" R	400.000	5.698	11.395	0.040	As Existing	-	80

ELEVATION	STATION										
	6+000	6+085.160 6+100 6+092.314	6+200	6+300	6+333.200 6+348.752	6+400	6+436.650 6+448.085	6+500	6+600		
PROPOSED HEIGHT	2.060	1.960 2.020 1.960	2.040	1.860	1.920 1.880	2.010	2.010 1.960	1.730	1.640		
EXISTING HEIGHT	1.910	1.830 1.870 1.910	1.890	1.770	1.770 1.730	1.860	1.860 1.810	1.580	1.890		
HORIZONTAL CURVATURE	R=∞ L=85.160m	R=400m L=7.150m	R=∞ L=240.890m	R=400m L=13.550m	R=∞ L=89.940m	R=400m L=11.400m	R=∞ L=151.910m				
VERTICAL CURVATURE	A : EXISTING										
SUPERELEVATION	A : EXISTING										
ACCUMULATED DISTANCE	0+000	0+085.160 0+100 0+092.314	0+200	0+300	0+333.200 0+348.752	0+400	0+436.650 0+448.085	0+500	0+600		

BASIC DESIGN STUDY ON THE PROJECT FOR
ROAD IMPROVEMENT WORKS IN TONGATAPU IN THE KINGDOM OF TONGA

SCALE
HOR: 1:1000
VER: 1:100

PLAN AND PROFILE
SECTION I-(112/13) STA. 6+600- STA. 7+200

SHEET NO.
3-12

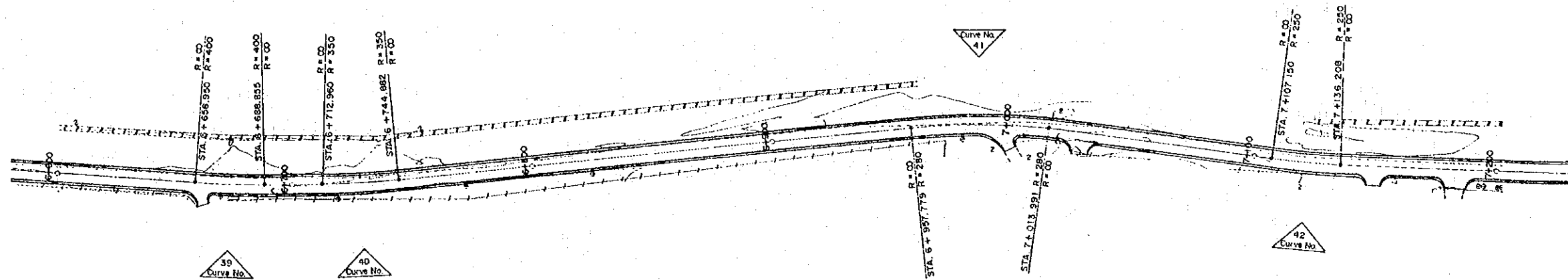

CURVE NO.	COORDINATES		ELEMENTS OF CURVES							
	NORTHING	EASTING	Def. Angle	Radius	T	Lc	E	e%	w	V(kph)
39	4 051.483	10 569.149	04°17' 01" L	400.000	14.960	29.905	0.280	existing	-	80
40	4 057.776	10 625.825	05°13' 32" L	350.000	15.972	31.921	0.360	existing	-	80
41	4 110.306	10 875.471	11°30' 09" R	280.000	28.201	56.212	1.420	existing	-	80
42	4 107.561	11 011.529	08°39' 34" L	250.000	14.545	29.037	0.420	existing	-	80

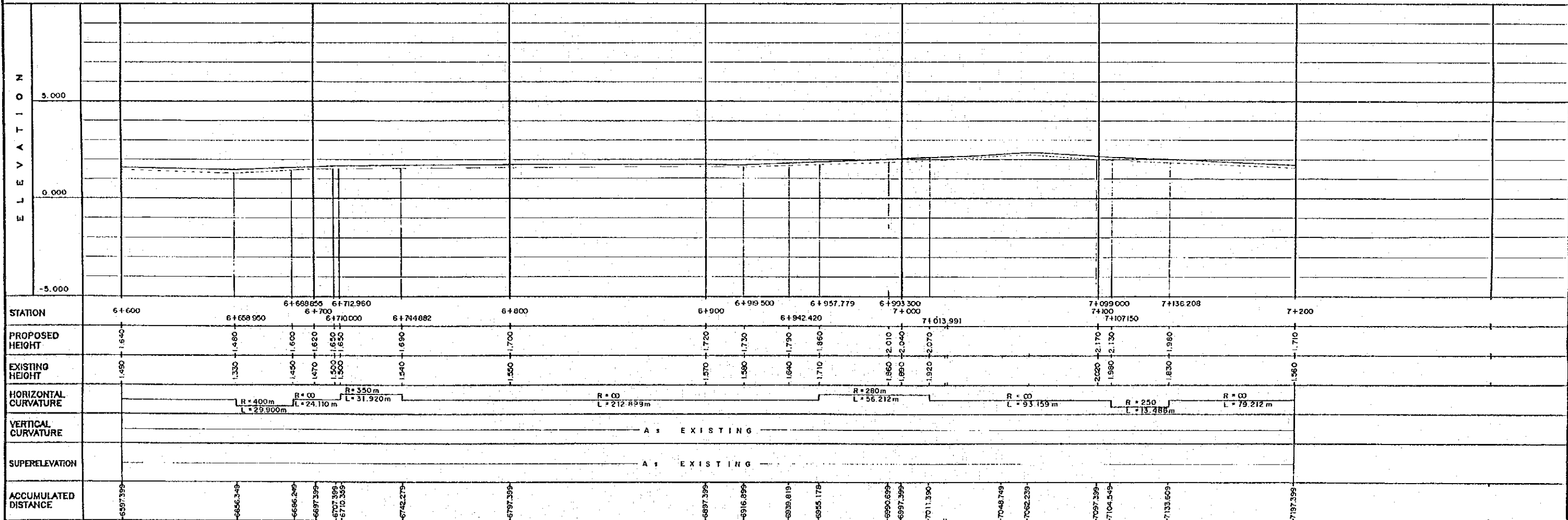

BASIC DESIGN STUDY ON THE PROJECT FOR
ROAD IMPROVEMENT WORKS IN TONGATAPU IN THE KINGDOM OF TONGA

SCALE	PLAN AND PROFILE	SHEET NO.
HOR: 1:1000	SECTION 1-1(13/13) STA. 7+200- STA. 7+600	3-13
VER: 1:100		

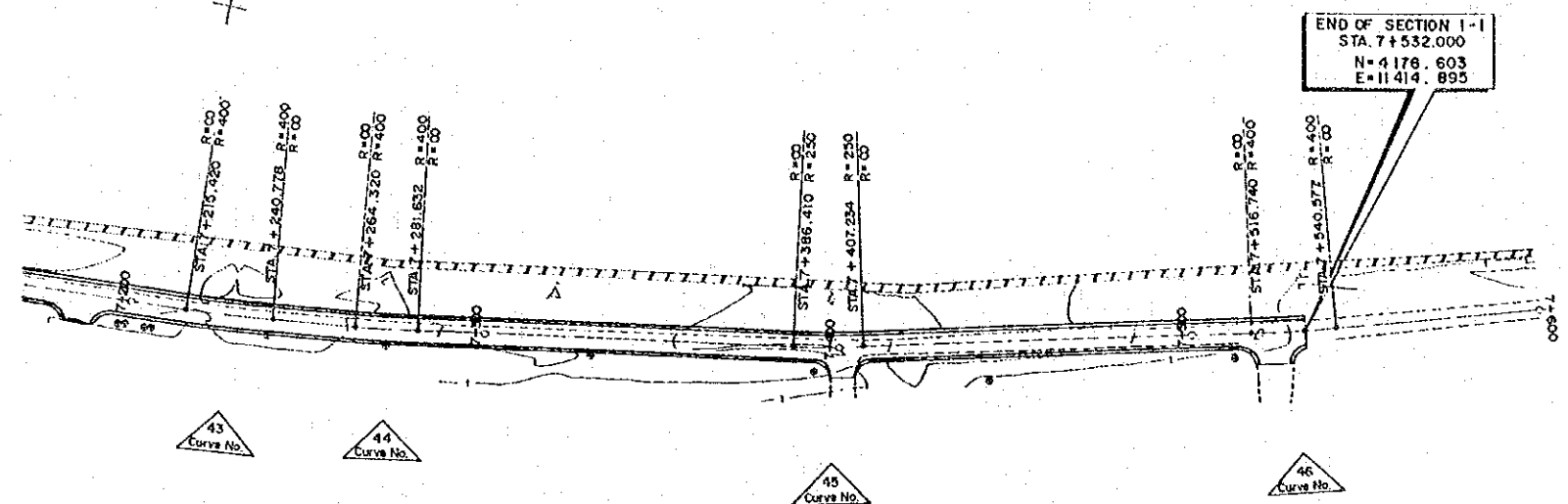
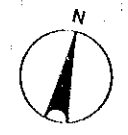

CURVE NO.	COORDINATES		ELEMENTS OF CURVES									
	NORTHING	EASTING	Def. Angle	Radius	T	Lo	E	a%	W	V(kph)		
43	4114.721	11117.729	03°37'56" L	400.000	12.693	25.358	0.200	At Existing	-	80		
44	4120.571	11162.228	02°28'47" L	400.000	8.657	17.312	0.090	At Existing	-	80		
45	4142.012	11284.211	04°46'21" L	250.000	10.418	20.824	0.220	At Existing	-	80		
46	4175.561	11411.717	03°24'52" L	400.000	11.922	23.937	0.180	At Existing	-	80		
47	4176.603	11414.895	END OF PROJECT									

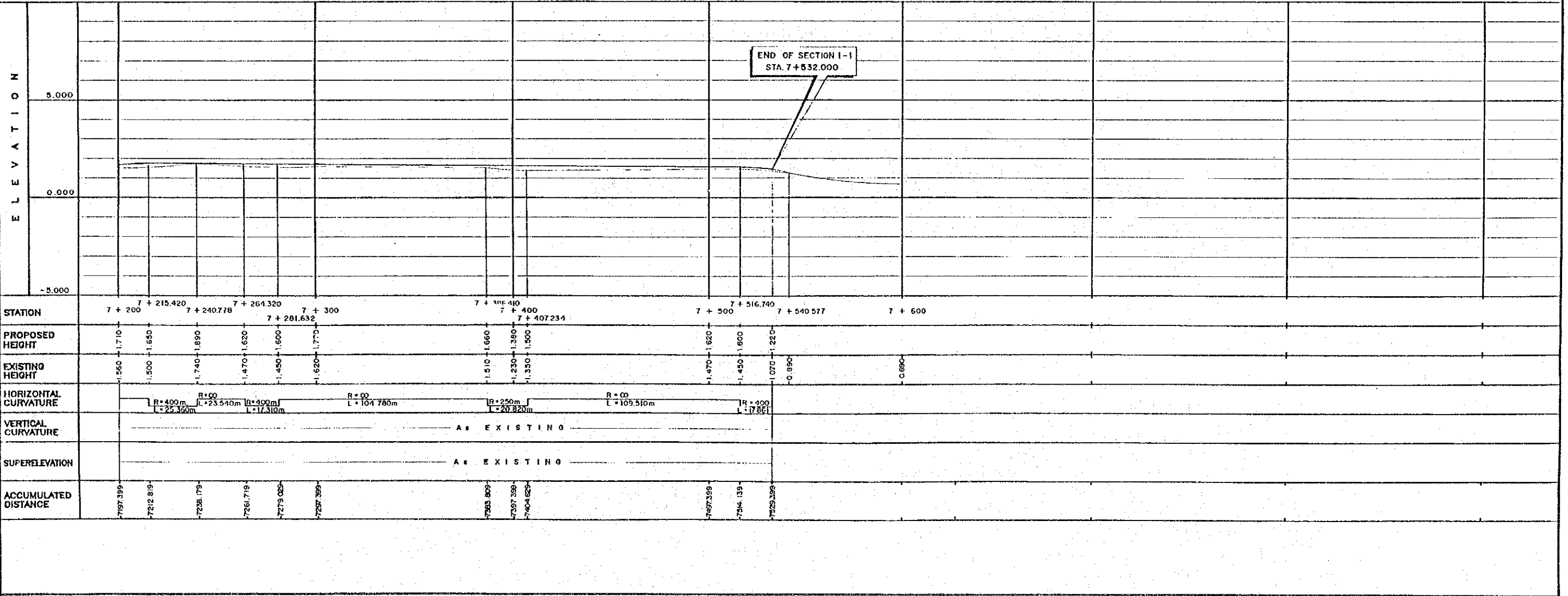

BASIC DESIGN STUDY ON THE PROJECT FOR ROAD IMPROVEMENT WORKS IN TONGATAPU IN THE KINGDOM OF TONGA

SCALE	PLAN AND PROFILE	SHEET NO.
HOR: 1:1000 VER: 1:100	SECTION 1-2 (1/10) (STA. 0+000 - STA. 0+600)	3 - 14

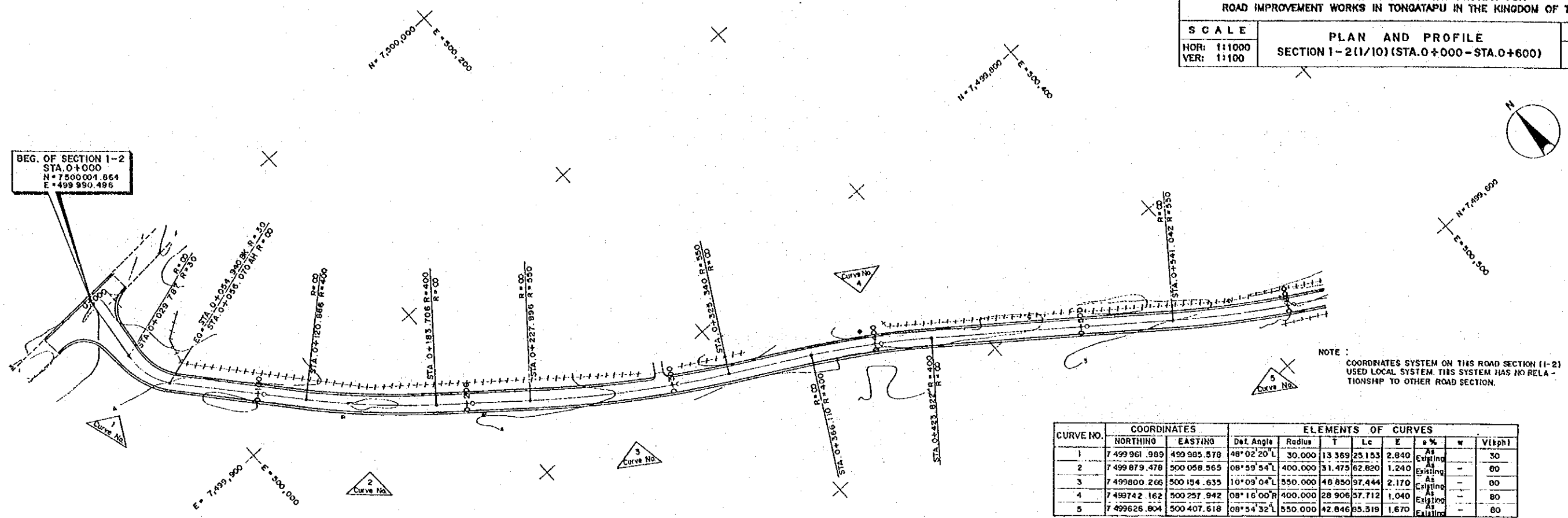

CURVE NO.	COORDINATES		ELEMENTS OF CURVES							
	NORTHING	EASTING	Def. Angle	Radius	T	Lc	E	Δ%	w	V(kph)
1	7 499 961.989	499 985.578	48° 02' 20" L	30.000	13.369	25.153	2.840	As Existing	-	30
2	7 499 879.478	500 058.565	08° 59' 54" L	400.000	31.473	62.620	1.240	As Existing	-	80
3	7 499 800.266	500 154.635	10° 09' 04" L	550.000	46.850	97.444	2.170	As Existing	-	80
4	7 499 742.162	500 257.942	08° 16' 00" R	400.000	28.906	57.712	1.040	As Existing	-	80
5	7 499 626.804	500 407.618	08° 54' 32" L	550.000	42.846	85.319	1.670	As Existing	-	80

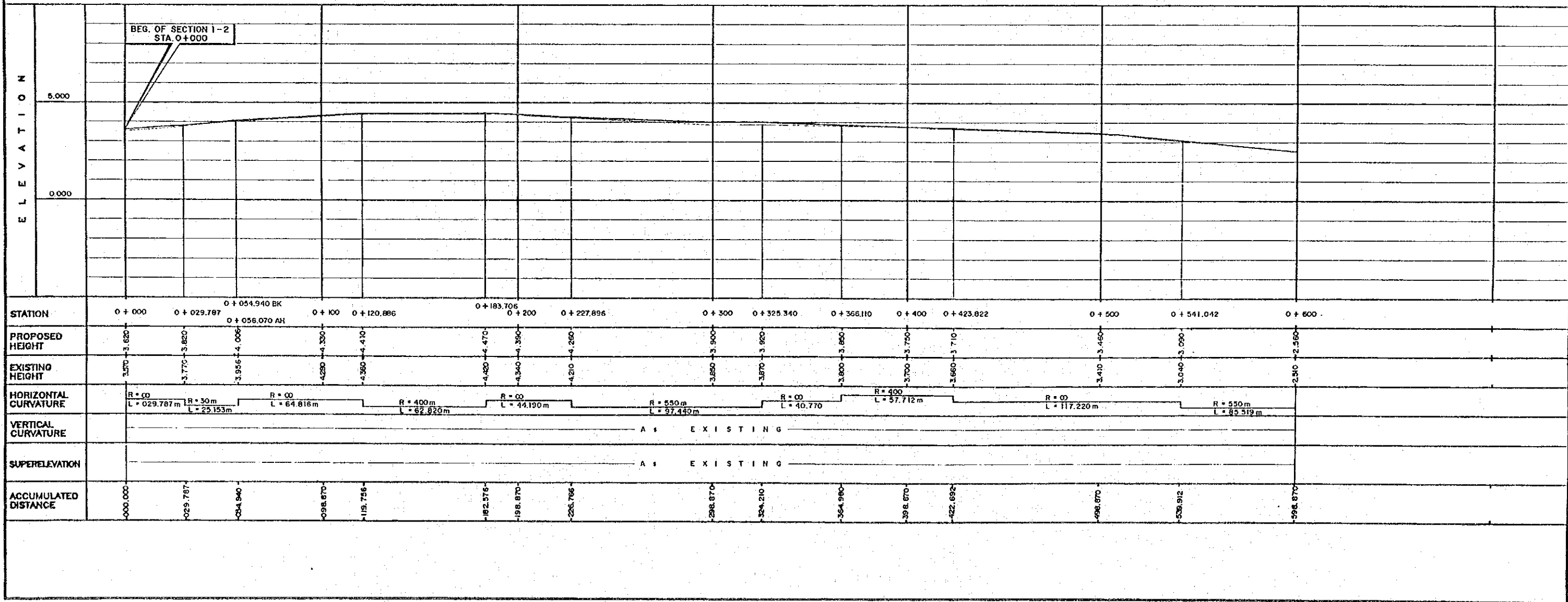

BASIC DESIGN STUDY ON THE PROJECT FOR
ROAD IMPROVEMENT WORKS IN TONGATAPU IN THE KINGDOM OF TONGA

SCALE
HOR: 1:1000
VER: 1:100

PLAN AND PROFILE
SECTION 1-2(2/10) (STA. 0+600 - STA. 1+200)

SHEET NO.
3 - 15

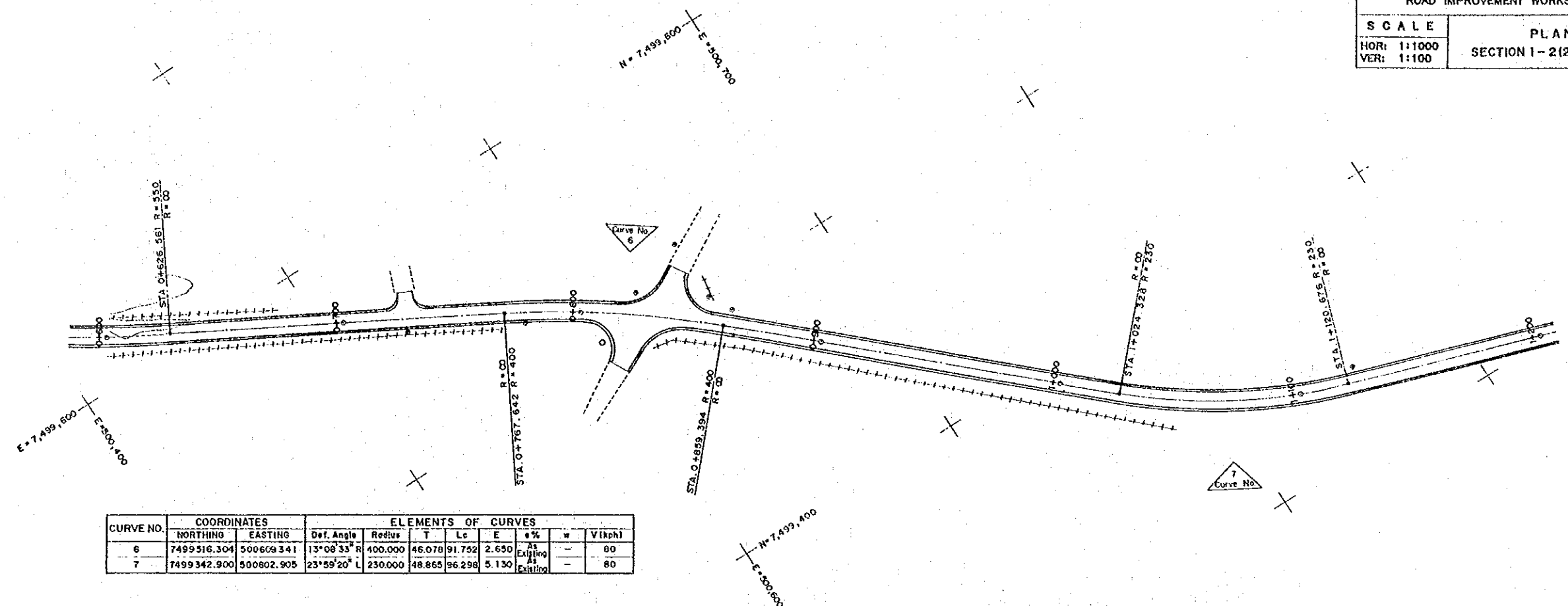

CURVE NO.	COORDINATES		ELEMENTS OF CURVES							
	NORTHING	EASTING	Def. Angle	Radius	T	Lc	E	± %	w	V(kph)
6	7499 516.304	500609 341	13°08'33" R	400.000	46.078	91.752	2.650	As Existing	-	80
7	7499 342.900	500802.905	23°59'20" L	230.000	48.865	96.298	5.130	As Existing	-	80

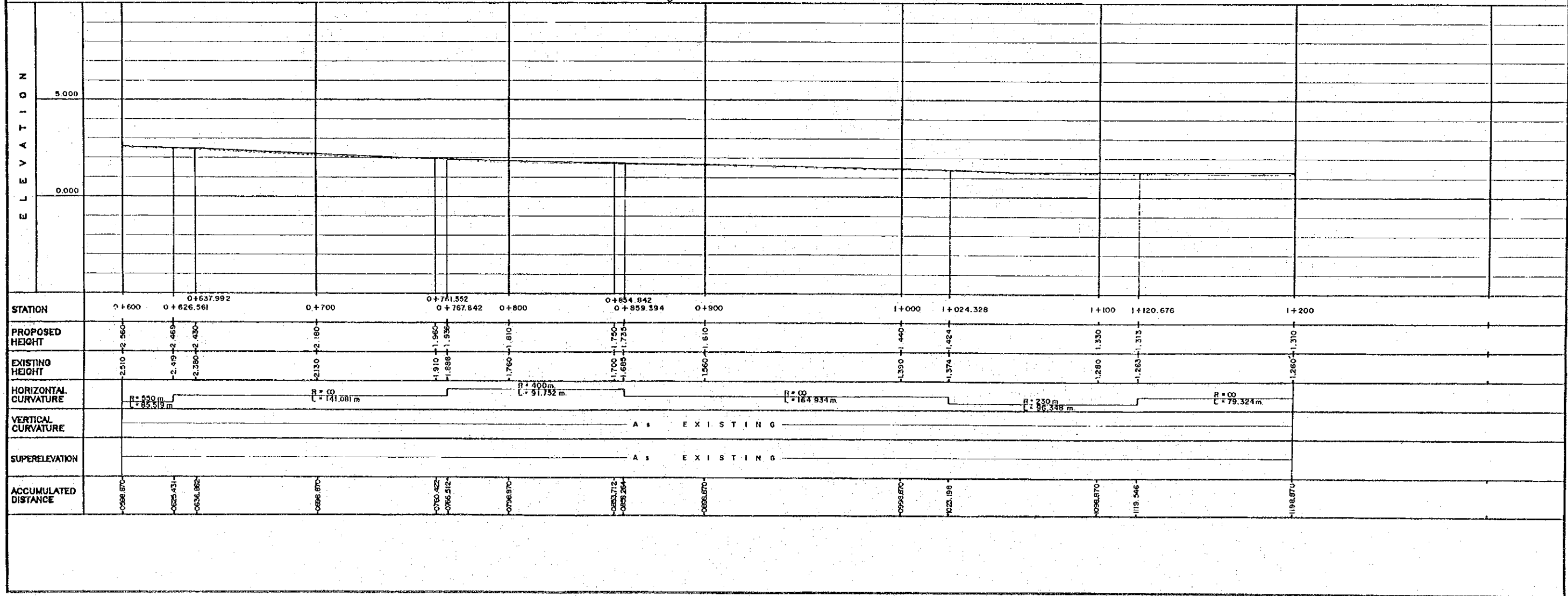

BASIC DESIGN STUDY ON THE PROJECT FOR ROAD IMPROVEMENT WORKS IN TONGATAPU IN THE KINGDOM OF TONGA

SCALE
HOR: 1:1000
VER: 1:100

PLAN AND PROFILE
SECTION 1-2(3/10) (STA. 1+200 - STA. 1+800)

SHEET NO.
3 - 16

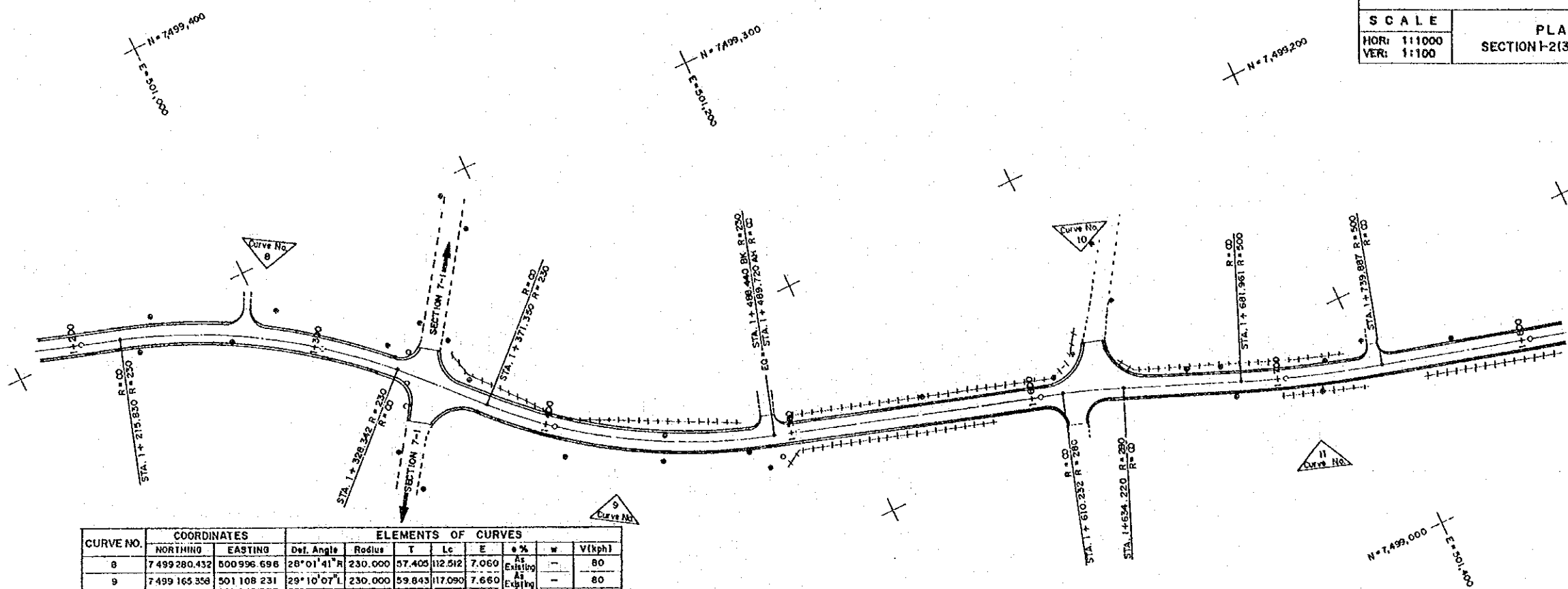

CURVE NO.	COORDINATES		ELEMENTS OF CURVES							
	NORTHING	EASTING	Def. Angle	Radius	T	Lc	E	e %	w	V(kph)
8	7 499 280.432	600 996.698	28° 01' 41" R	230.000	57.405	112.512	7.060	As Existing	-	80
9	7 499 165.358	501 108.231	29° 10' 07" L	230.000	59.843	117.090	7.660	As Existing	-	80
10	7 499 109.938	501 292.450	04° 54' 51" R	280.000	12.001	23.988	0.260	As Existing	-	80
11	7 499 077.282	501 371.936	06° 36' 16" L	500.000	28.995	57.926	0.840	As Existing	-	80

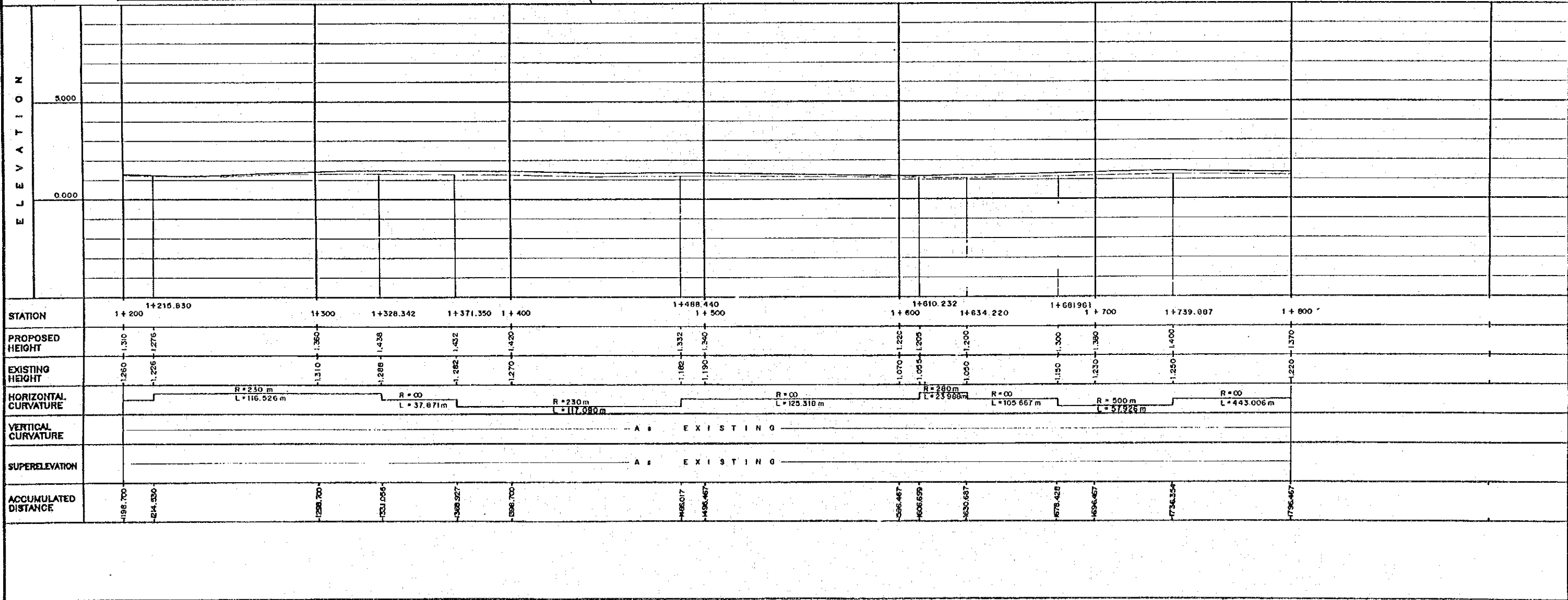

BASIC DESIGN STUDY ON THE PROJECT FOR
ROAD IMPROVEMENT WORKS IN TONGATAPU IN THE KINGDOM OF TONGA

SCALE
HOR: 1:1000
VER: 1:100

PLAN AND PROFILE
SECTION-2(4/10) STA. 1+800 - STA. 2+400

SHEET NO.
3-17

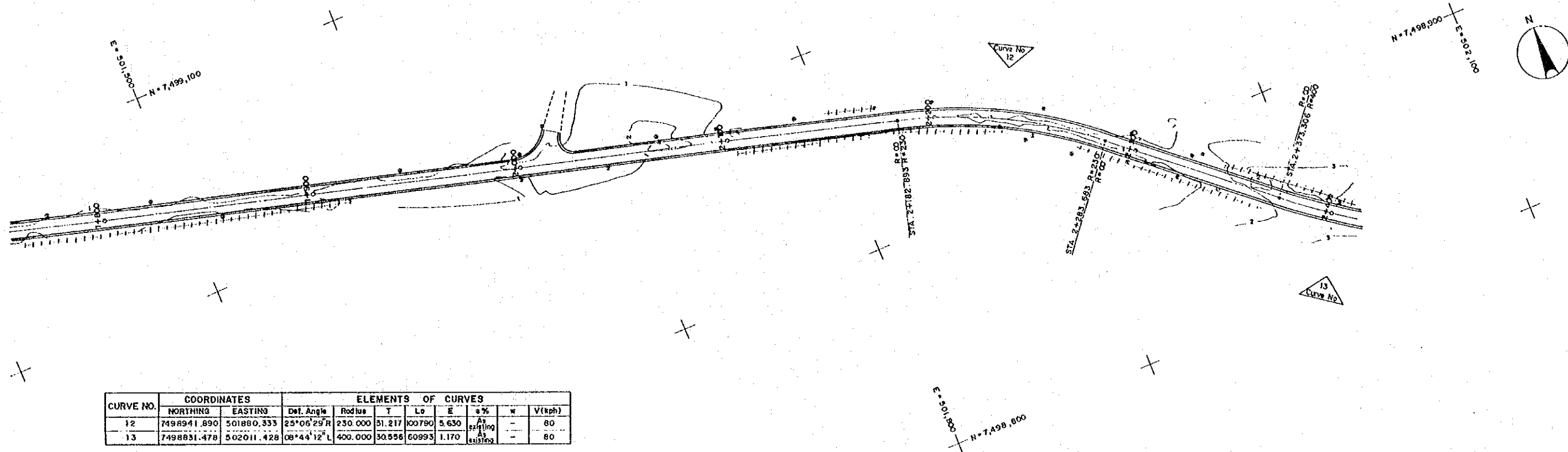

CURVE NO.	COORDINATES		ELEMENTS OF CURVES							
	NORTHING	EASTING	Def. Angle	Radius	T	Lc	E	g %	w	V(kph)
12	7498941.890	501880.333	25°06'29"R	250.000	51.217	100790	5.630	At 25.110g	-	80
13	7498831.478	502011.428	08°44'12"L	400.000	30.556	60993	1.170	At 10.10g	-	80

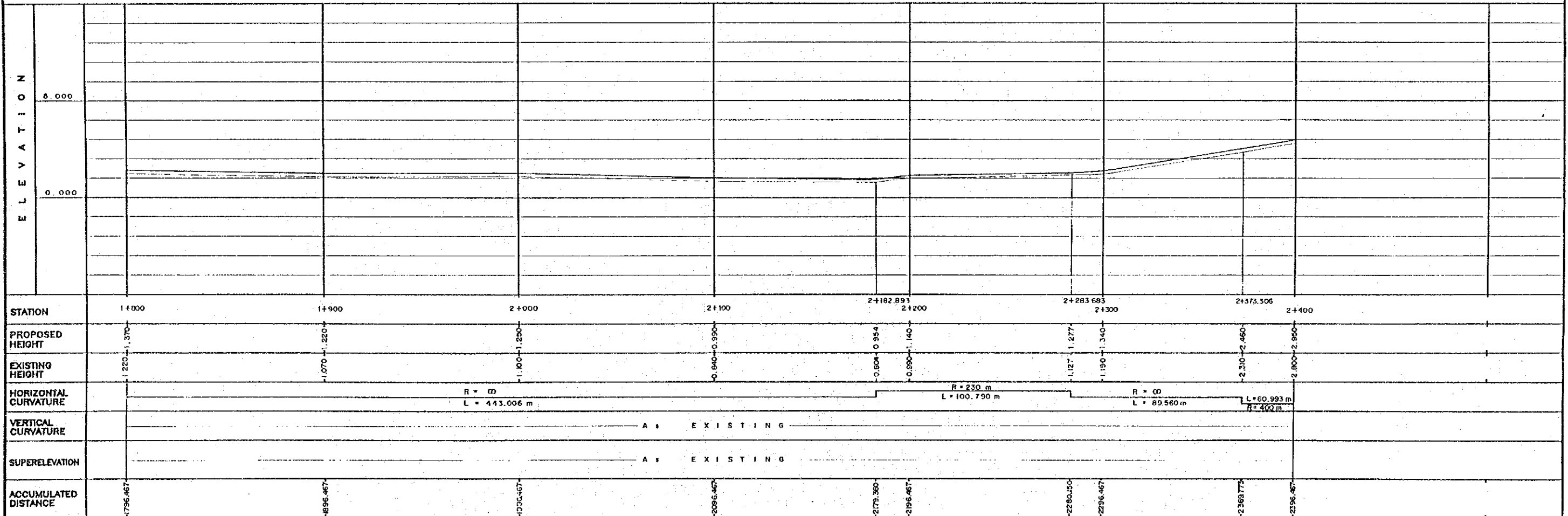

BASIC DESIGN STUDY ON THE PROJECT FOR ROAD IMPROVEMENT WORKS IN TONGATAPU IN THE KINGDOM OF TONGA

SCALE HOR: 1:1000 VER: 1:100	PLAN AND PROFILE	SHEET NO. 3 - 18
	SECTION 1-2(5/10) STA. 2+400 -- STA. 3+000	

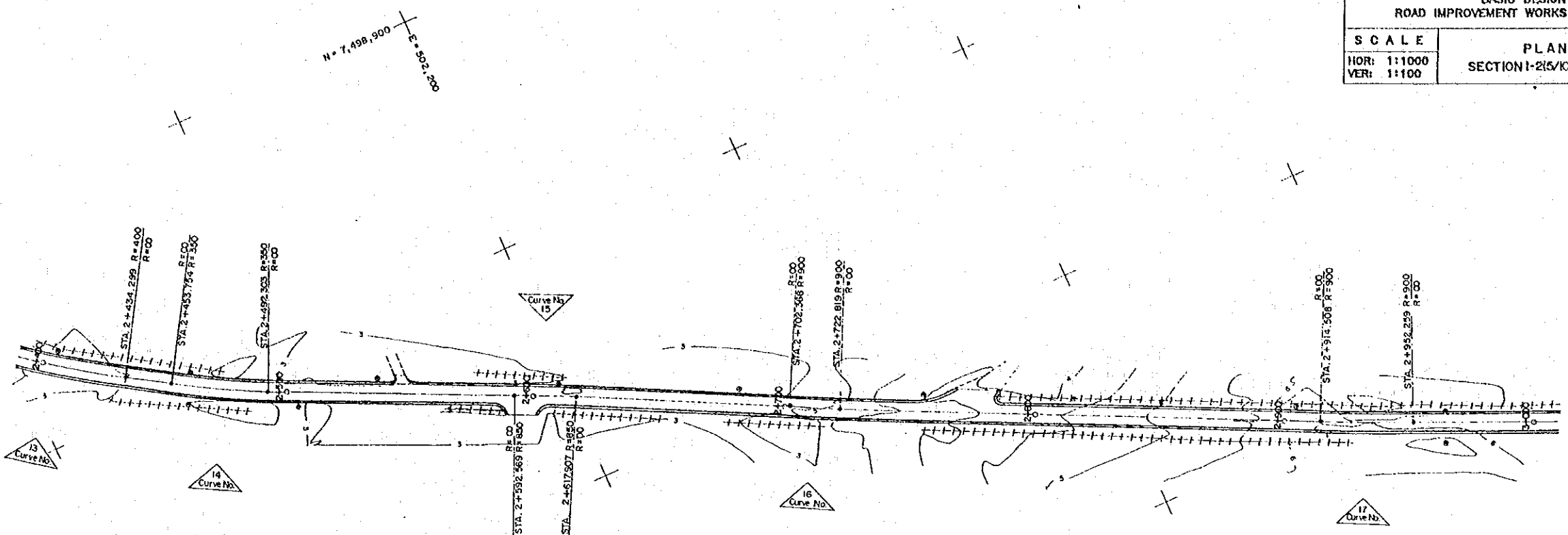
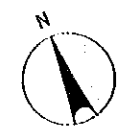

CURVE NO.	COORDINATES		ELEMENTS OF CURVES							
	NORTHING	EASTING	Def Angle	Radius	T	Lc	E	e %	W	V(kph)
14	7498795.402	502070.603	06° 16' 38" L	350.000	19.294	38.549	0.530	As Existing	-	80
15	7498739.398	502190.389	01° 42' 29" R	850.000	12.671	25.340	0.090	As Existing	-	80
16	7498691.050	502286.214	01° 18' 07" L	900.000	10.226	20.451	0.060	As Existing	-	80
17	7498596.121	502485.589	02° 24' 12" L	900.000	18.879	37.751	0.200	As Existing	-	80

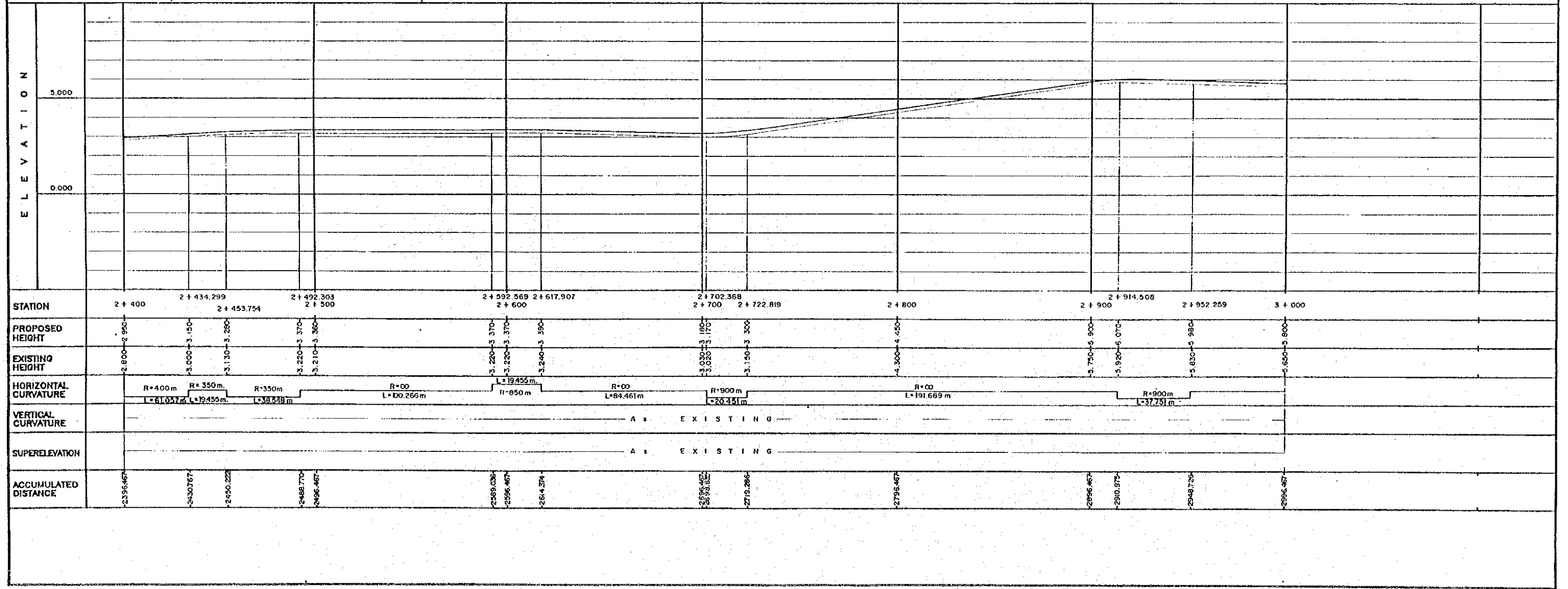

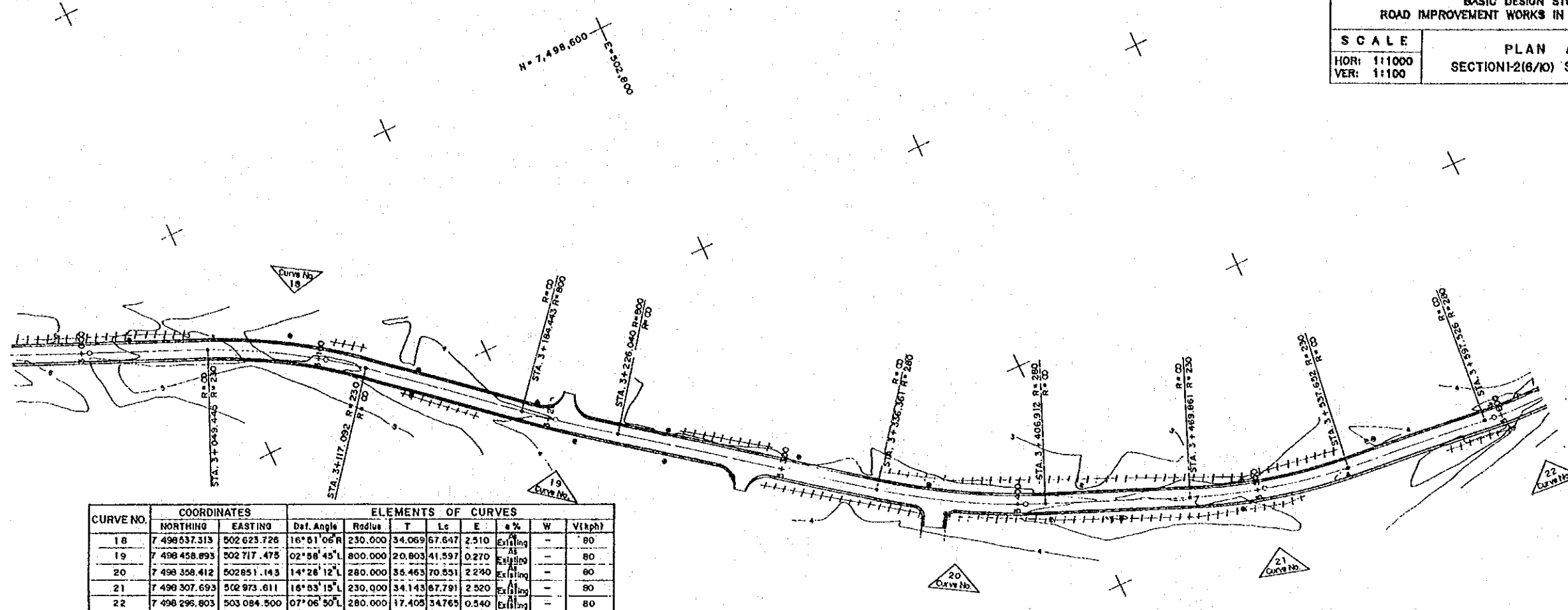

CURVE NO.	COORDINATES		ELEMENTS OF CURVES							
	NORTHING	EASTING	Def. Angle	Radius	T	Lc	E	e %	W	V(kph)
18	7 498 537.313	502 623.726	16° 01' 06" R	230.000	34.069	67.647	2.510	Existing	-	80
19	7 498 458.893	502 717.475	02° 58' 45" L	800.000	20.803	41.597	0.270	Existing	-	80
20	7 498 358.412	502 851.143	14° 26' 12" L	280.000	35.463	70.551	2.240	Existing	-	80
21	7 498 307.693	502 973.611	16° 03' 15" L	230.000	34.143	67.791	2.520	Existing	-	80
22	7 498 295.803	503 084.500	07° 06' 50" L	280.000	17.405	34.765	0.540	Existing	-	80

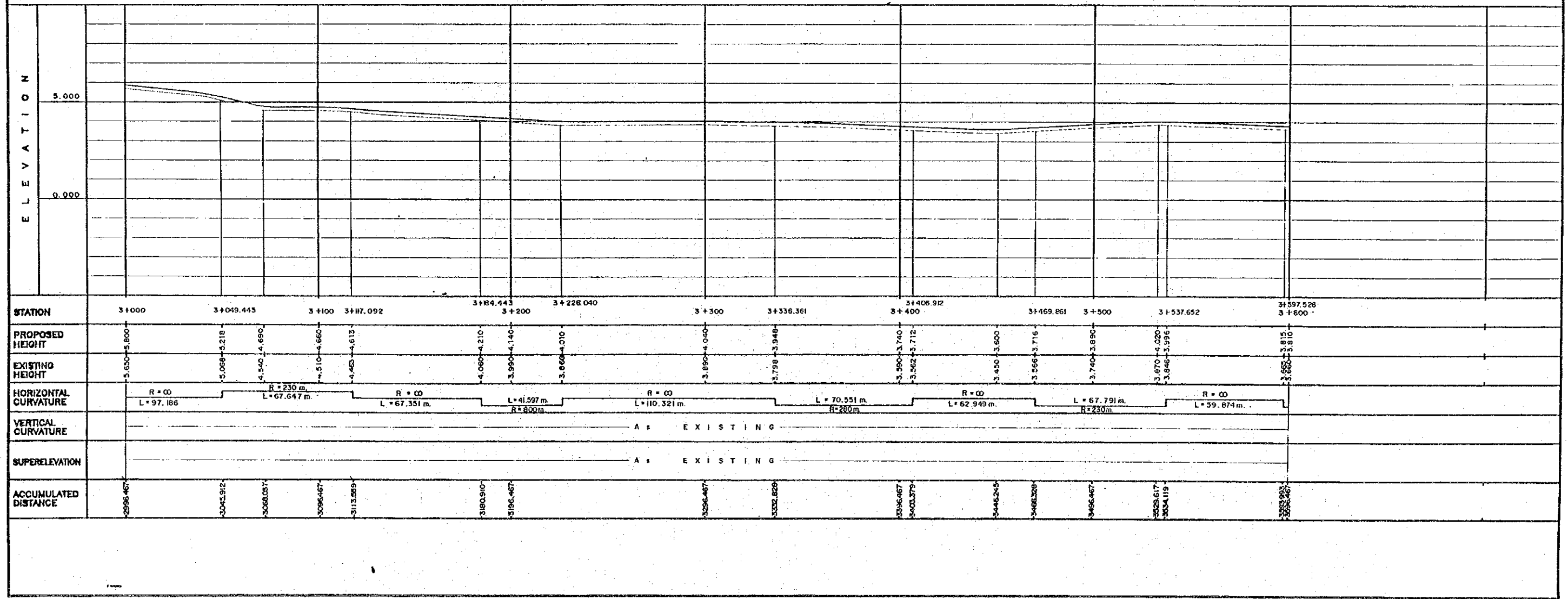

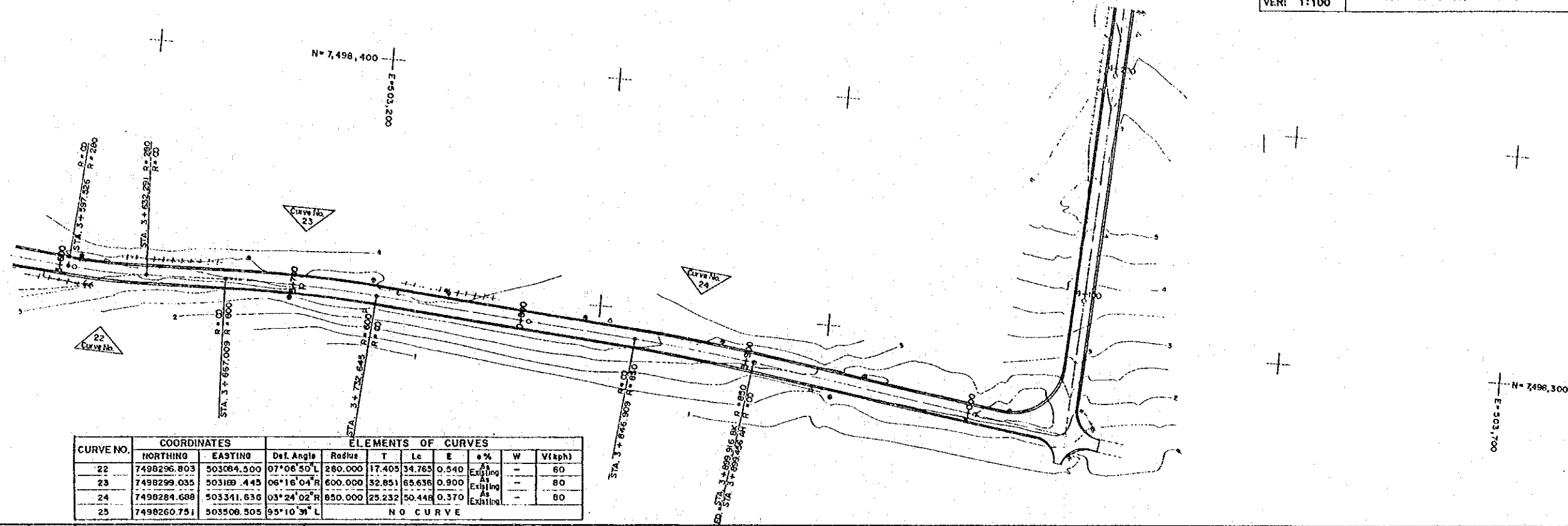

CURVE NO.	COORDINATES		ELEMENTS OF CURVES									
	NORTHING	EASTING	Def. Angle	Radius	T	Lc	E	e%	W	V(kph)		
22	7498296.803	503084.500	07°06'50" L	280.000	17.403	34.765	0.540	Existing	-	60		
23	7498299.035	503189.445	06°16'04" R	600.000	32.851	65.636	0.900	Existing	-	80		
24	7498284.688	503341.638	03°24'02" R	850.000	25.232	50.448	0.370	Existing	-	80		
25	7498260.751	503506.505	95°10'31" L	NO CURVE							-	-

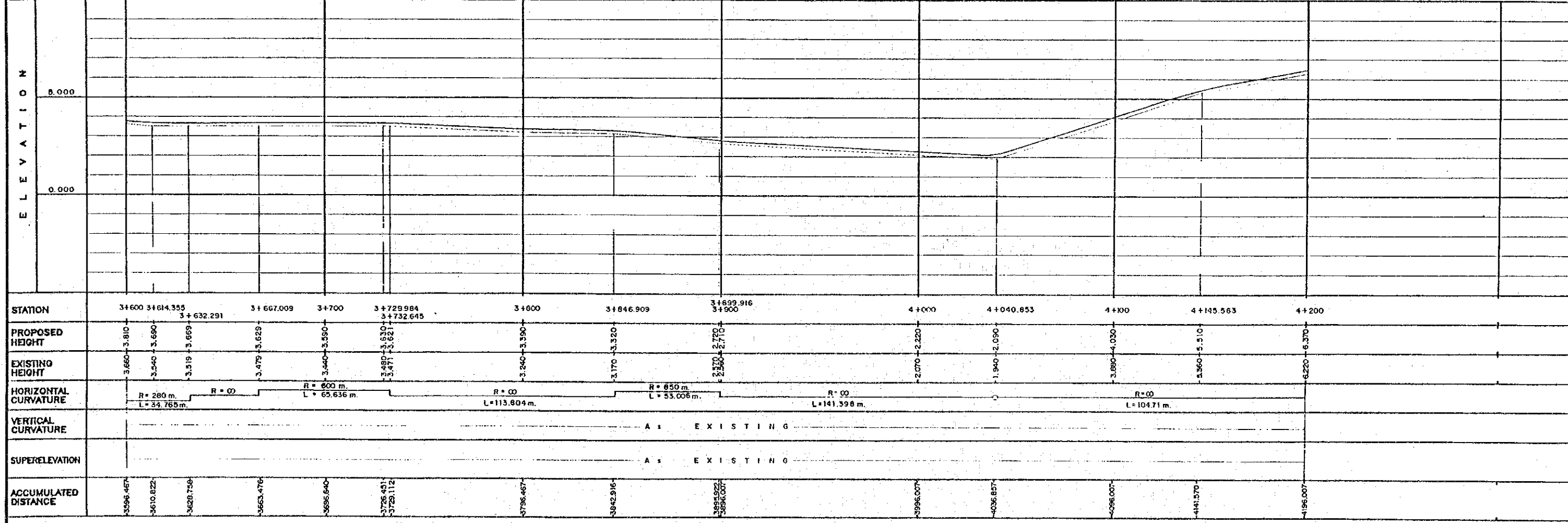

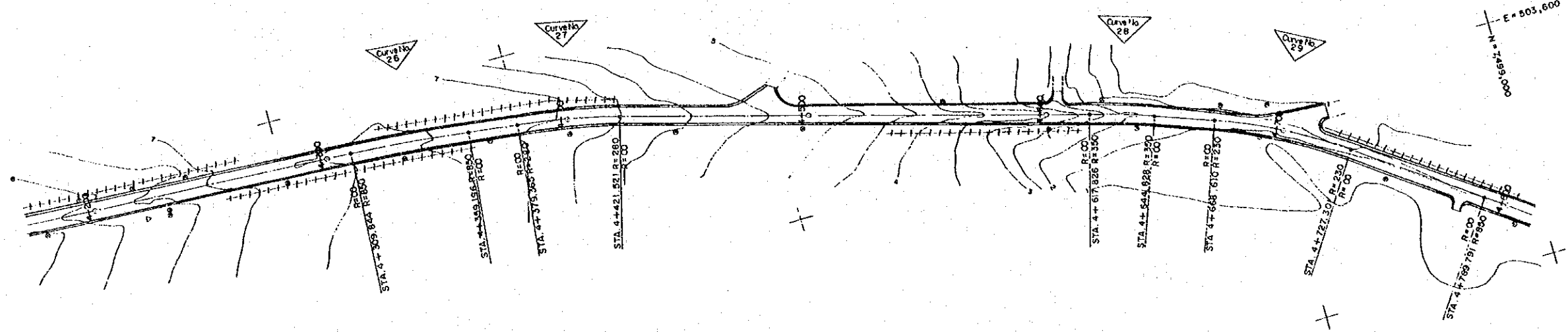

CURVE NO.	COORDINATES		ELEMENTS OF CURVES							
	NORTHING	EASTING	Def. Angle	Radius	T	Lo	E	g%	W	V(kph)
26	7498554.026	503523.809	03° 19' 26" R	850.000	24.683	49.352	0.360	Existing	-	80
27	7498619.598	503531.084	08° 37' 25" R	280.000	21.118	42.156	0.800	Existing	-	80
28	7498841.647	503594.488	04° 25' 13" R	350.000	13.508	27.002	0.260	Existing	-	80
29	7498904.270	503617.728	14° 37' 14" R	230.000	29.506	58.691	1.880	Existing	-	80

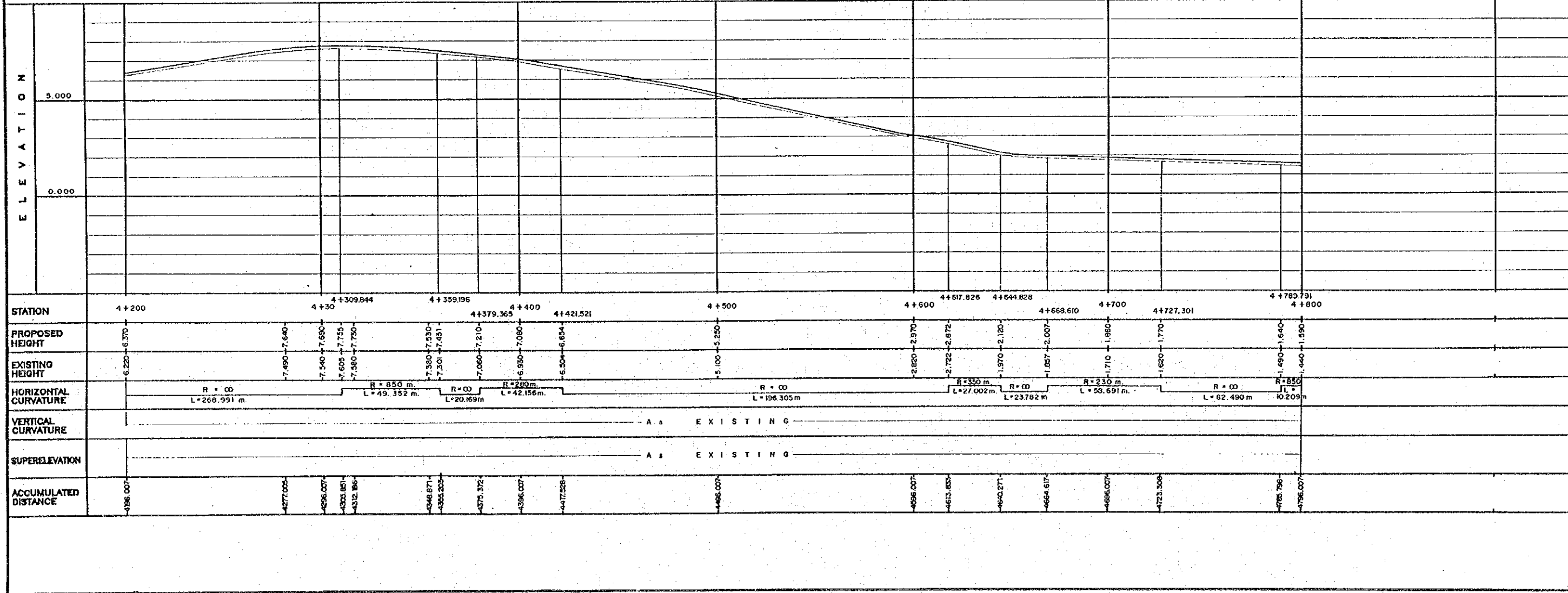

BASIC DESIGN STUDY ON THE PROJECT FOR
ROAD IMPROVEMENT WORKS IN TONGATAPU IN THE KINGDOM OF TONGA

SCALE
HOR: 1:1000
VER: 1:100

PLAN AND PROFILE
SECTION 1-2(S/O) STA. 4+800 - STA. 5+400

SHEET NO.
3-22

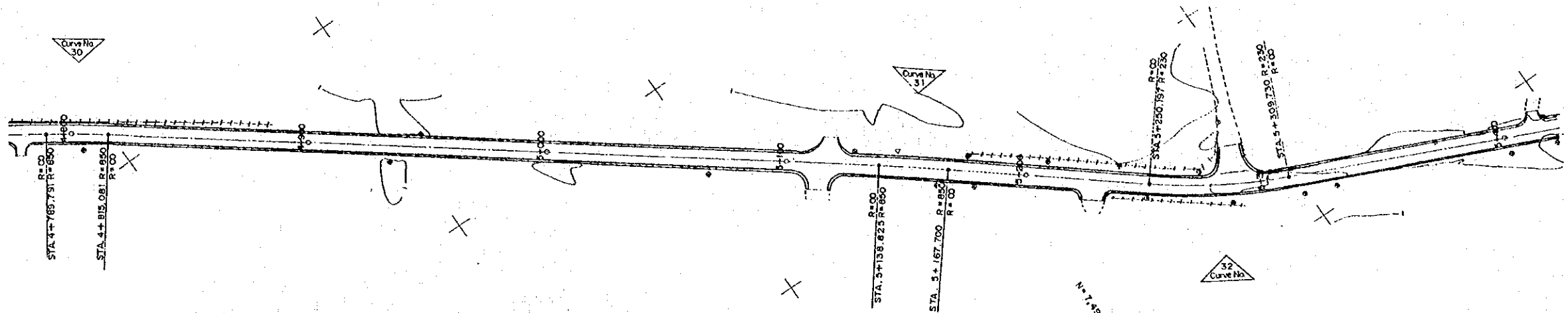

CURVE NO	COORDINATES		ELEMENTS OF CURVES							
	NORTHING	EASTING	Def. Angle	Radius	T	Lc	E	e%	W	V(kph)
30	7499 990.007	503 677.718	01° 42' 17" R	850.000	12 646	25.290	0.090	-	-	80
31	7499 271.345	503 887.513	01° 56' 47" R	850.000	14.439	28.875	0.120	As Existing	-	80
32	7499 371.967	503 967.732	14° 49' 49" L	230.000	29.934	59.633	1.940	As Existing	-	80
33	7499 610.040	504 072.744	END OF PROJECT							

ELEVATION	STATION											
	4+800	4+815.081	4+900	5+000	5+100	5+136.825	5+167.700	5+200	5+250.197	5+300	5+309.730	5+400
PROPOSED HEIGHT	1.530	1.610	1.520	1.460	1.560	1.566	1.645	1.650	1.645	1.670	1.677	1.740
EXISTING HEIGHT	1.440	1.460	1.370	1.310	1.430	1.446	1.495	1.470	1.495	1.520	1.527	1.590
HORIZONTAL CURVATURE	R = 850 m L = 15.031 m		R = ∞		R = 850 m L = 28.875 m		R = ∞		R = 230 m L = 59.533 m		R = ∞	
VERTICAL CURVATURE	A s EXISTING											
SUPERELEVATION	A s EXISTING											
ACCUMULATED DISTANCE	4796.007	4811.088	4896.007	4996.007	5086.007	5134.852	5163.707	5196.007	5246.204	5296.007	5305.737	

SCALE
HOR: 1:1000
VER: 1:100

PLAN AND PROFILE
SECTION 1-2(10/10) STA. 5+400 - STA 5+578.40

SHEET NO.
3-23

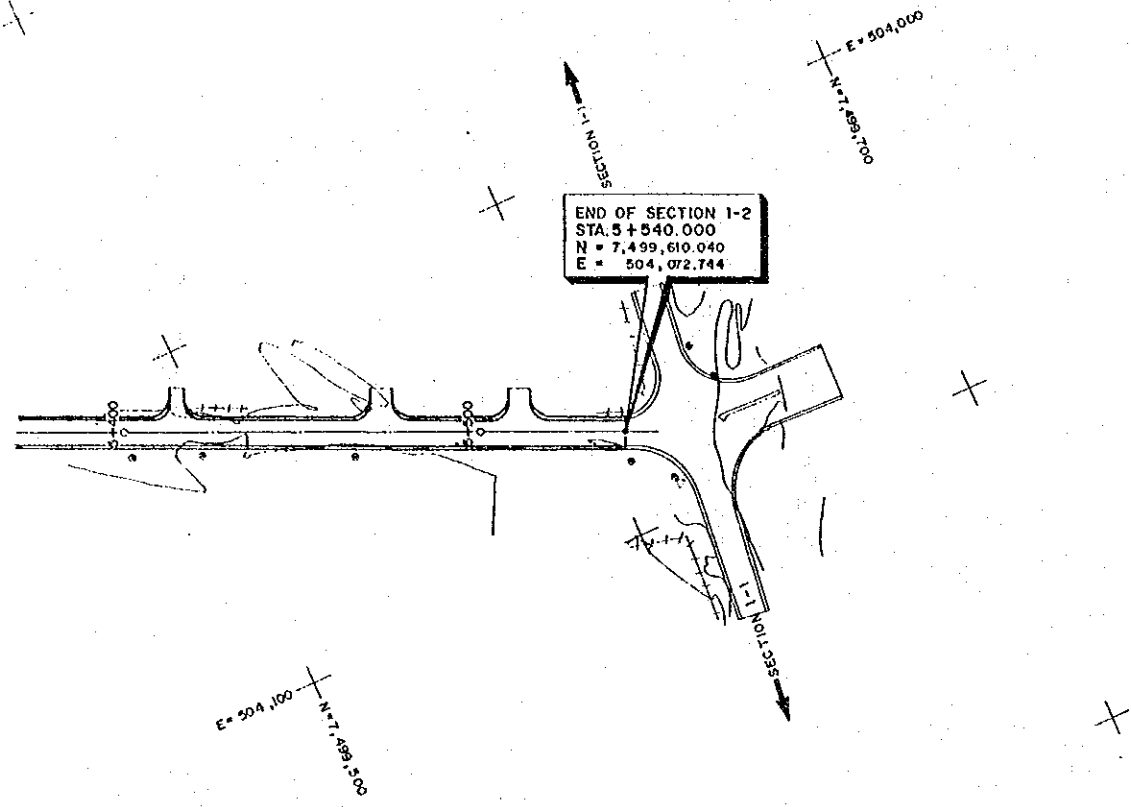

ELEVATION	5.000																			
	0.000																			
STATION	5+400		5+500	5+540																
PROPOSED HEIGHT	1.760		1.720	1.661																
EXISTING HEIGHT	1.590		1.570	1.511																
HORIZONTAL CURVATURE			R = ∞																	
VERTICAL CURVATURE			A = EXISTING																	
SUPERELEVATION			A = EXISTING																	
ACCUMULATED DISTANCE	5396.007		5492.007	5538.007																

END OF SECTION 1-2
STA. 5+540.000

SCALE
HOR: 1:1000
VER: 1:100

PLAN AND PROFILE
SECTION 7-III(8) STA. 0+000 - STA. 0+600

SHEET NO.
3-24



BEG. OF SECTION 7-1
STA. 0 + 014.000
N = 161924949
E = 187034.404

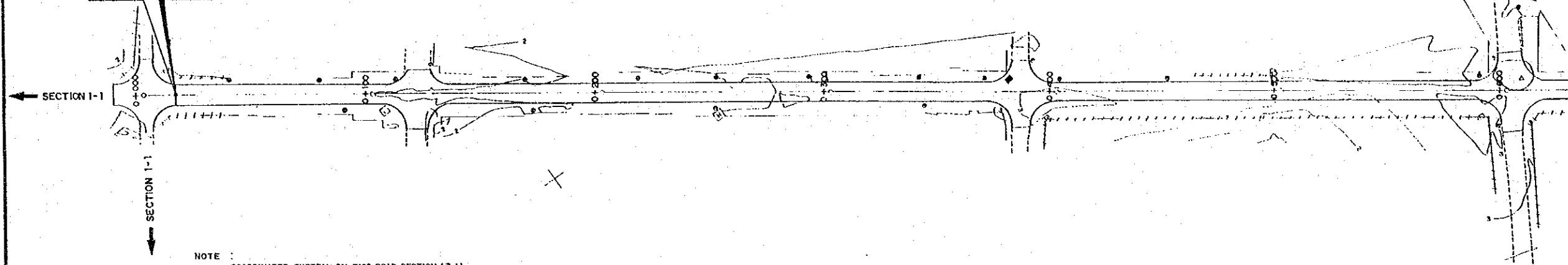

NOTE:
COORDINATES SYSTEM ON THIS ROAD SECTION (7-1)
USED LOCAL SYSTEM. THIS SYSTEM HAS NO RELATIONSHIP TO OTHER ROAD SECTION.

ELEVATION	5.000								
	0.000								
STATION	0 + 000	0 + 100	0 + 200	0 + 300	0 + 400	0 + 500	0 + 600		
PROPOSED HEIGHT		2.000-2.050	2.200-2.270	2.580-2.630	3.060-3.110	2.650-2.650	2.350-2.600		
EXISTING HEIGHT		2.000-2.050	2.200-2.270	2.580-2.630	3.060-3.110	2.650-2.650	2.350-2.600		
HORIZONTAL CURVATURE				R = ∞ L = 600 m					
VERTICAL CURVATURE				AS EXISTING					
SUPERELEVATION				AS EXISTING					
ACCUMULATED DISTANCE	0000.000	0096.000	0192.000	0288.000	0384.000	0480.000	0576.000		

BEG. OF SECTION 7-1
STA. 0 + 014.000

BASIC DESIGN STUDY ON THE PROJECT FOR
ROAD IMPROVEMENT WORKS IN TONGATAPU IN THE KINGDOM OF TONGA

SCALE	PLAN AND PROFILE	SHEET NO.			
			HOR: 1:1000	SECTION 7-1(2/8) STA. 0+600--STA. 1+200	3 - 25
			VER: 1:100		

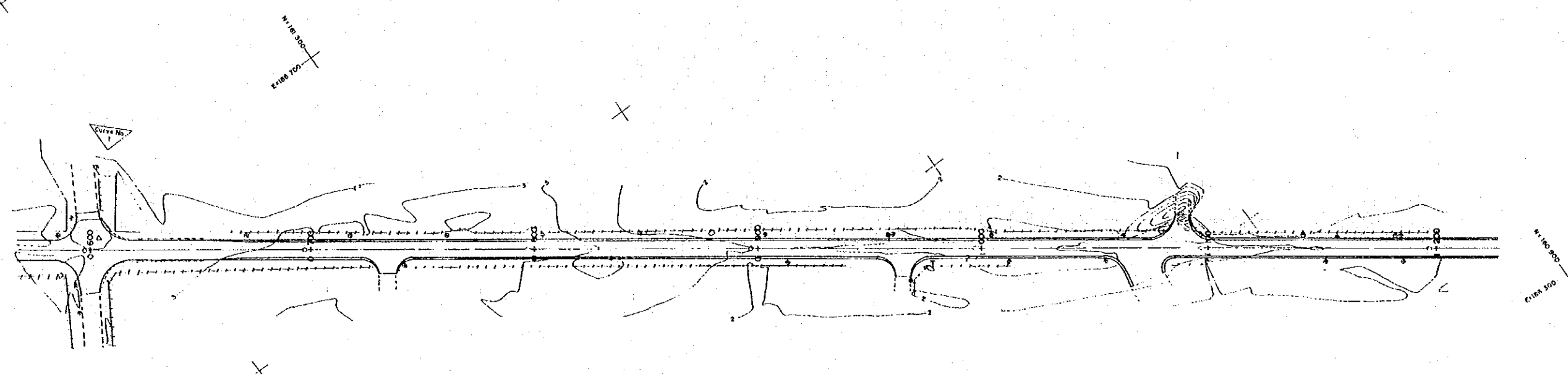

CURVE NO.	COORDINATES		ELEMENTS OF CURVES								
	NORTHING	EASTING	Del. Angle	Radius	T	Lc	E	e%	w	V (kph)	
1	161 429.361	186 686.799	00°11'36" R								NO CURVE

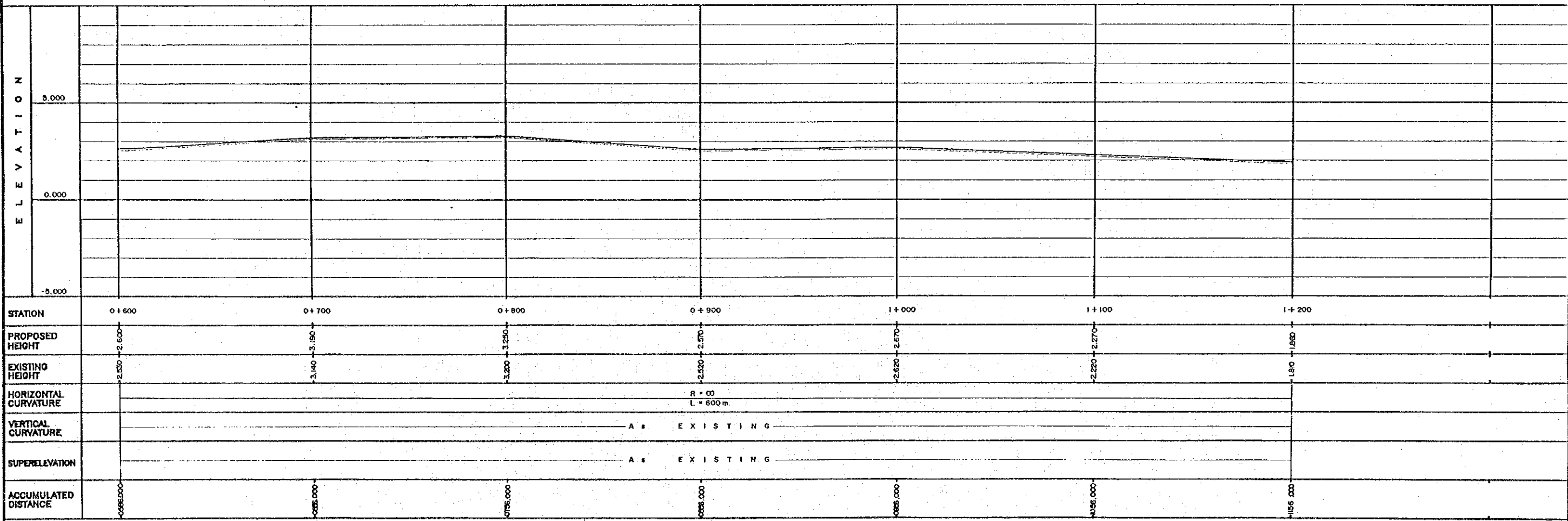

BASIC DESIGN STUDY ON THE PROJECT FOR
ROAD IMPROVEMENT WORKS IN TONGATAPU IN THE KINGDOM OF TONGA

SCALE
HORI: 1:1000
VER: 1:100

PLAN AND PROFILE
SECTION 7-1(13/8) STA. 1+200 - STA. 1+800

SHEET NO.
3-26

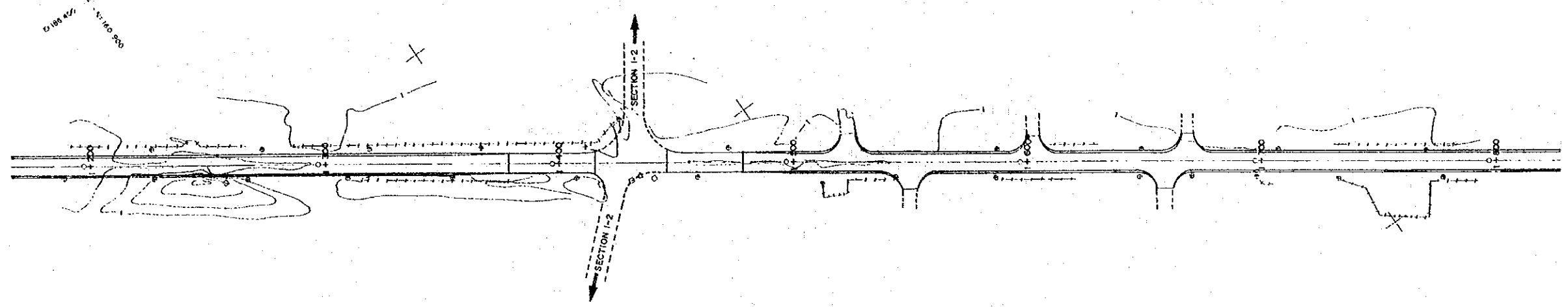

ELEVATION								
	5.000							
0.000								
STATION	1+200	1+300	1+400	1+500	1+600	1+700	1+800	
PROPOSED HEIGHT	1.800	1.570	1.490	1.500	1.430	1.350	1.290	
EXISTING HEIGHT	1.810	1.420	1.420	1.330	1.440	1.300	1.240	
HORIZONTAL CURVATURE				R = ∞ L = 600 m				
VERTICAL CURVATURE	A = EXISTING							
SUPERELEVATION	A = EXISTING							
ACCUMULATED DISTANCE	1185.000	1285.000	1385.000	1485.000	1585.000	1685.000	1785.000	
			EXCEPTION 30.000 m					

BASIC DESIGN STUDY ON THE PROJECT FOR
ROAD IMPROVEMENT WORKS IN TONGATAPU IN THE KINGDOM OF TONGA

SCALE	PLAN AND PROFILE	SHEET NO.
HORI: 1:1000 VER: 1:100	SECTION 7- (14/8) STA. 1+800 - STA. 2+400	3-27

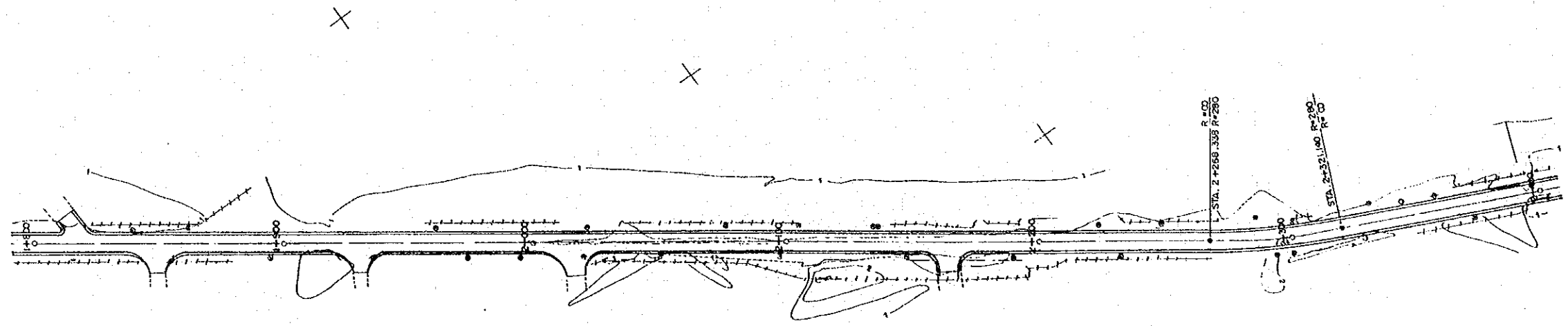

CURVE NO.	COORDINATES		ELEMENTS OF CURVES							
	NORTHING	EASTING	Del Angle	Radius	T	Lo	E	a%	w	V(kph)
2	160 049.400	185 711.986	10° 48' 17" L	280.000	26.479	52.802	1.250	As Existing	-	80

ELEVATION	STATION									
	1+800	1+900	2+000	2+100	2+200	2+268.338	2+300	2+321.140	2+400	
5.000										
0.000										
PROPOSED HEIGHT	1.250	1.250	1.540	1.580	1.720	1.796	1.780	1.865	1.980	
EXISTING HEIGHT	1.240	1.240	1.480	1.530	1.670	1.746	1.730	1.815	1.930	
HORIZONTAL CURVATURE	R = ∞ L = 1662.998 m.									
VERTICAL CURVATURE	L = 52.802 m. R = 280 m.									
SUPERELEVATION	AS EXISTING									
ACCUMULATED DISTANCE	1756.000	1856.000	1956.000	2056.000	2156.000	2224.338	2256.000	2272.140	2356.000	

SCALE
HOR: 1:1000
VER: 1:100

PLAN AND PROFILE
SECTION 7-(15/8) STA. 2+400 - STA. 3+000

SHEET NO.
3-28

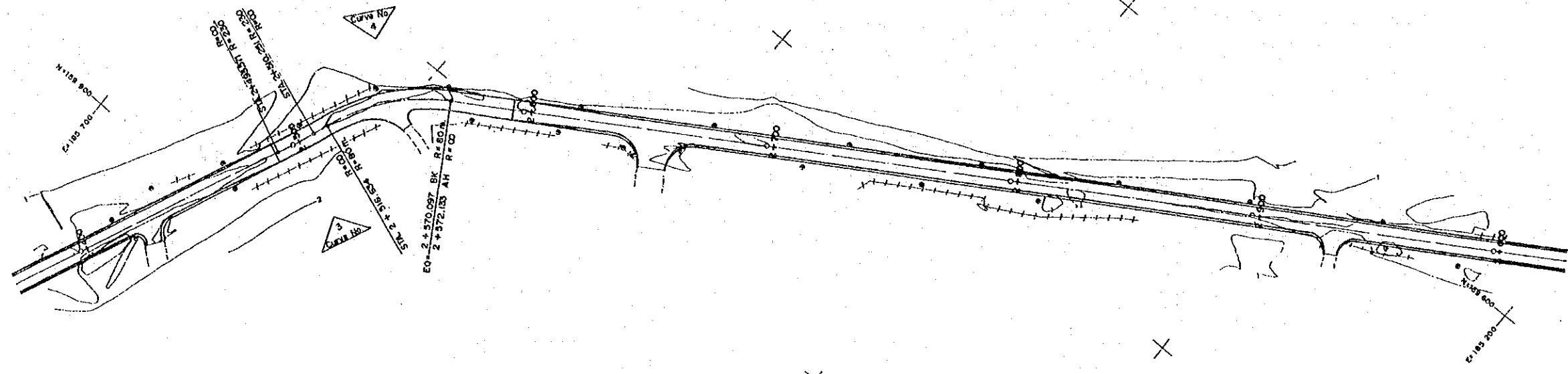

CURVE NO.	COORDINATES		ELEMENTS OF CURVES							
	NORTHING	EASTING	Def. Angle	Radius	T	Le	E	e %	w	V (kph)
3	159 660.789	185 626.255	04° 09' 19" L	230.000	8.344	16.680	0.150	As Existing	-	80
4	159 620.923	185 611.525	38° 17' 24" R	80.000	27.773	53.463	4.680	As Existing	-	80

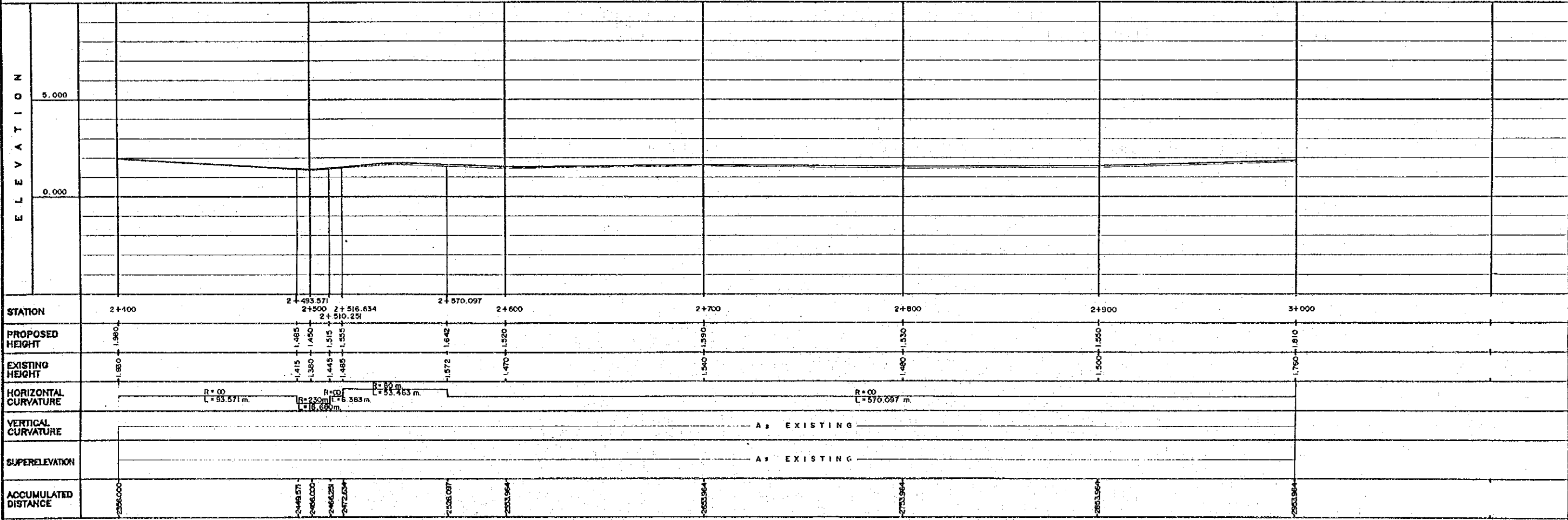

BASIC DESIGN STUDY ON THE PROJECT FOR
ROAD IMPROVEMENT WORKS IN TONGATAPU IN THE KINGDOM OF TONGA

SCALE	PLAN AND PROFILE	SHEET NO.
VER: 1:1100		

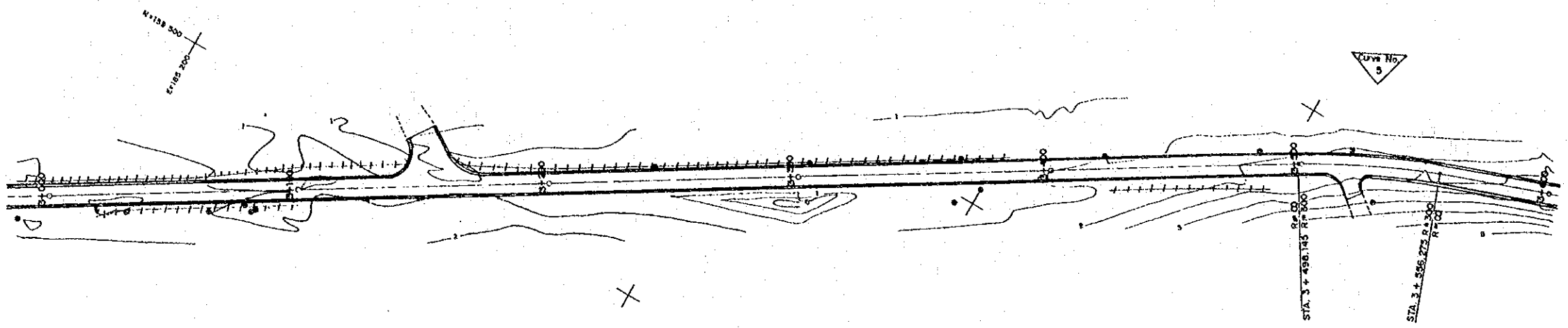

CURVE NO.	COORDINATES		ELEMENTS OF CURVES							
	NORTHING	EASTING	Def. Angle	Radius	T	Lo	E	e%	w	V(kph)
5	159 308.850	18770.030	11°06'07" R	300.000	29.158	58.130	1.410	Existing	-	80

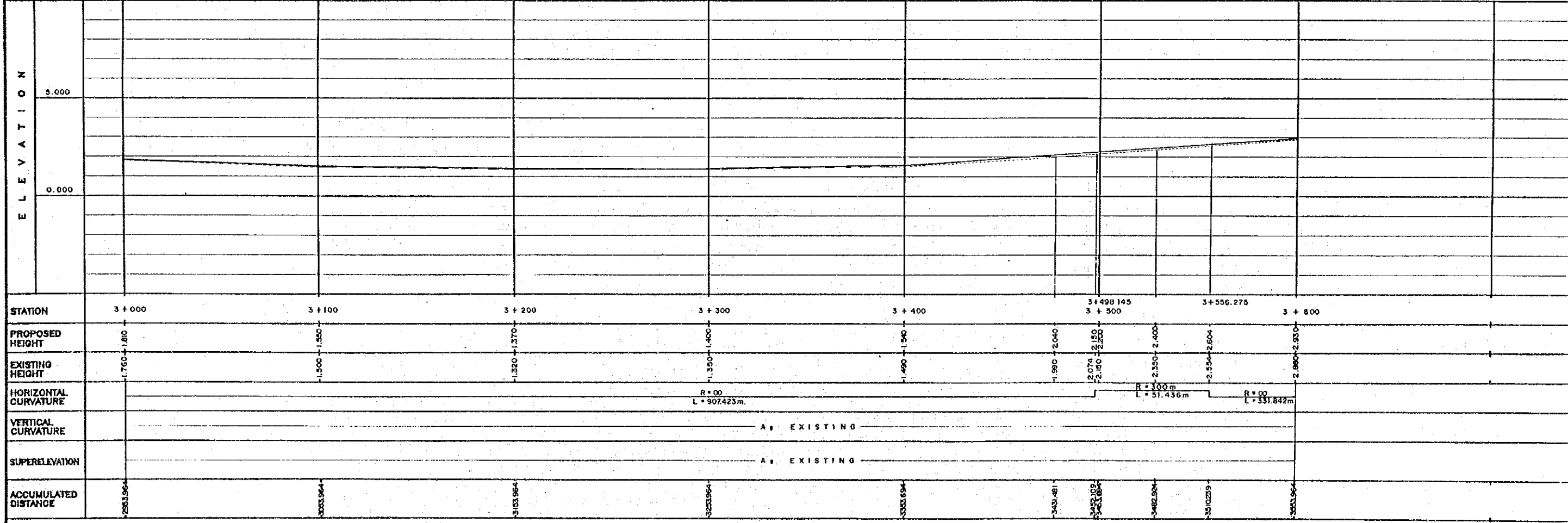

STATION	3 + 000	3 + 100	3 + 200	3 + 300	3 + 400	3 + 498.145 3 + 500	3 + 556.275	3 + 600
PROPOSED HEIGHT								
EXISTING HEIGHT	1.760	1.550	1.370	1.400	1.540	2.040	2.400	2.350
HORIZONTAL CURVATURE				R = ∞ L = 907.423m			R = 100m L = 51.436m	R = ∞ L = 331.842m
VERTICAL CURVATURE								
SUPERELEVATION								
ACCUMULATED DISTANCE	2883.964	3003.964	3123.964	3243.964	3363.964	3483.964	3603.964	3723.964

BASIC DESIGN STUDY ON THE PROJECT FOR
ROAD IMPROVEMENT WORKS IN TONGATAPU IN THE KINGDOM OF TONGA

SCALE
HOR: 1:1000
VER: 1:100

PLAN AND PROFILE
SECTION 7-(117/8) STA. 3+600 - STA. 4+200

SHEET NO.
3-30

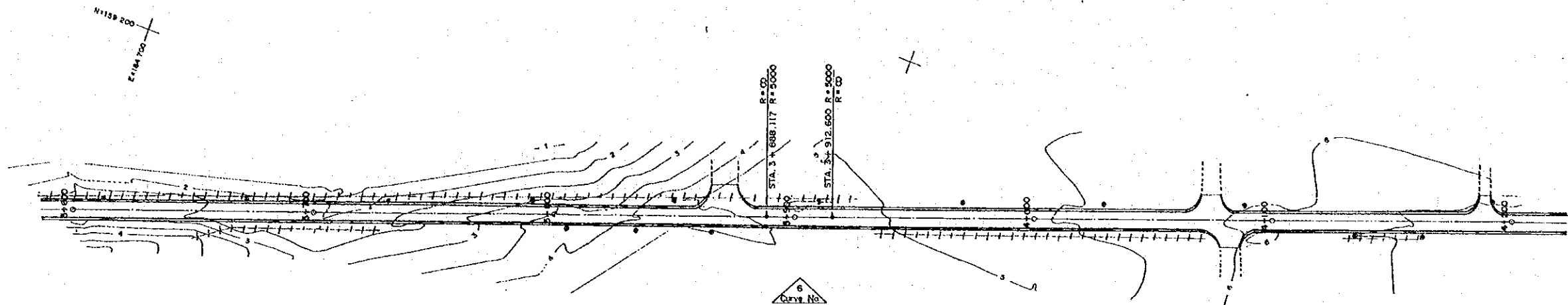

CURVE NO.	COORDINATES		ELEMENTS OF CURVES									
	NORTHING	EASTING	Def. Angle	Radius	T	Lo	E	e%	w	V (αph)		
6	159 176.983	184 420.038	00°18'50"L	5,000.000	12 242	24 483	0.010	Existing	-	80		

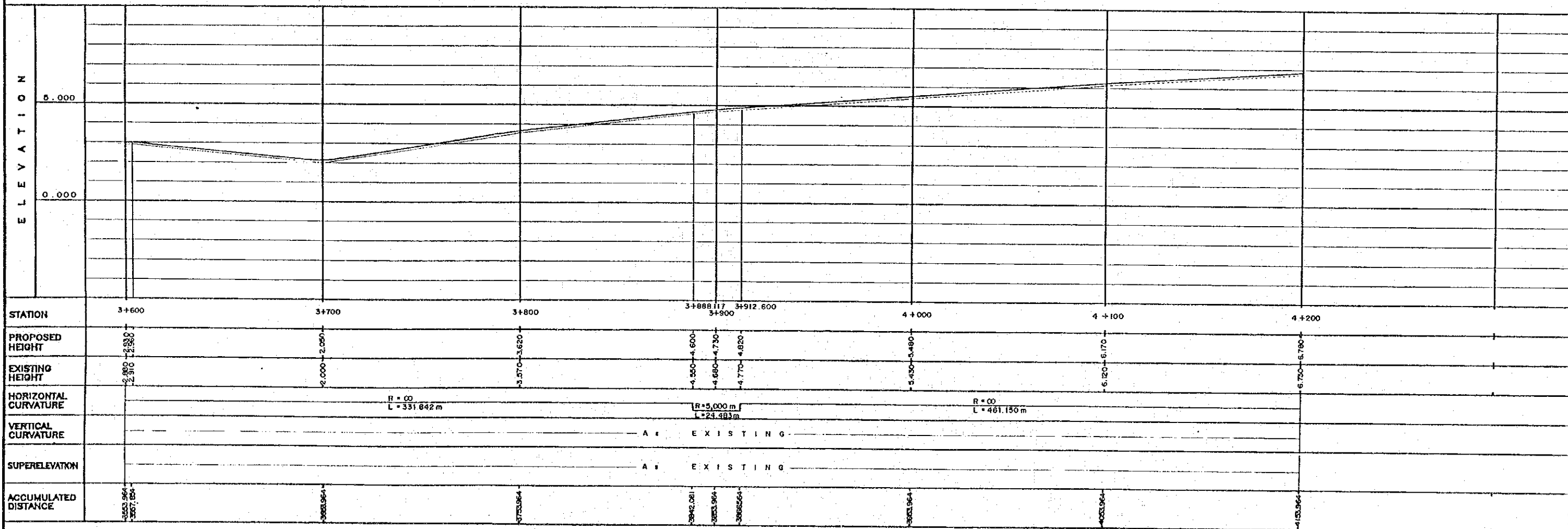

BASIC DESIGN STUDY ON THE PROJECT FOR ROAD IMPROVEMENT WORKS IN TONGATAPU IN THE KINGDOM OF TONGA

SCALE	PLAN AND PROFILE	SHEET NO.
HOR: 1:11000 VER: 1:1100	SECTION 7-2(1/18) STA. 4+200 - STA. 4+800	3-31

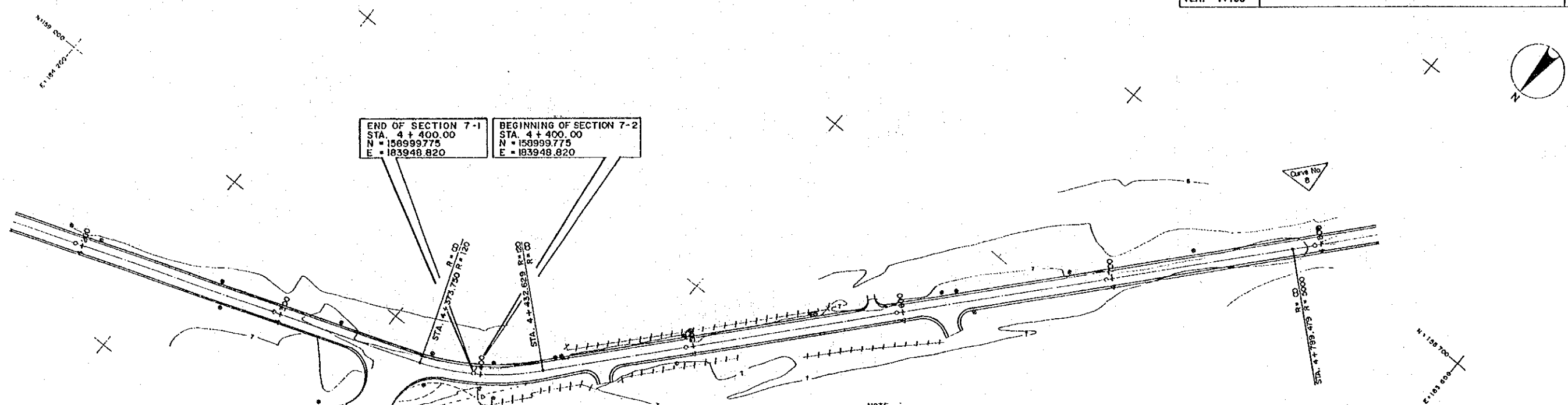

NOTE :
COORDINATES SYSTEM CONTINUE ROAD SECTION (7-1)
THE SAME COORDINATES UP TO STA. 7 + 103.830

CURVE NO.	COORDINATES		ELEMENTS OF CURVES							
	NORTHING	EASTING	Def. Angle	Radius	T	Lc	E	a%	w	V(kph)
7	158 999.775	183 948.820	28°06'46" L	120 000	300.45	58.879	3.700	Existing	-	60
8	158 700.107	183 685.761	00°16'18" L	5,000 000	11 654	23.707	0.010	Existing	-	80

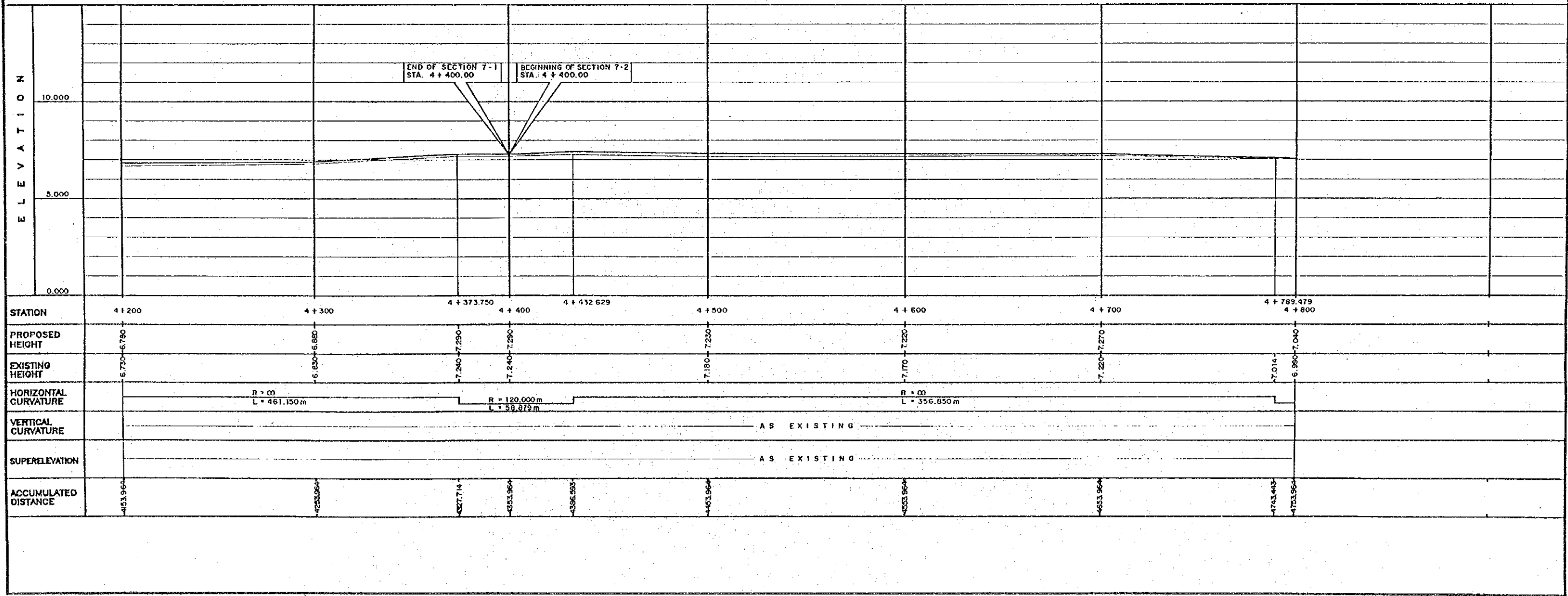

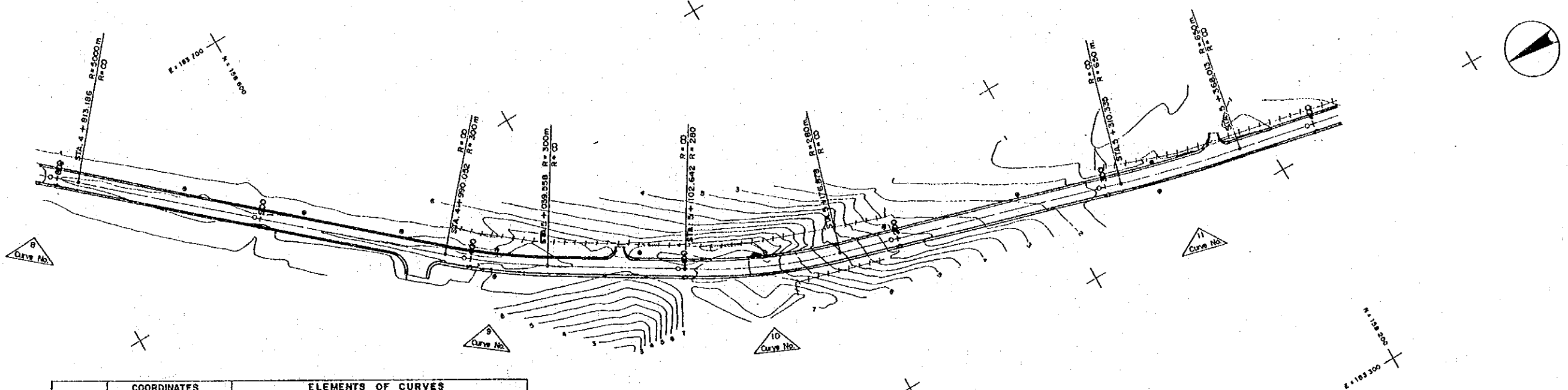

CURVE NO.	COORDINATES		ELEMENTS OF CURVES									
	NORTHING	EASTING	Del. Angle	Radius	T	Lc	E	g%	w	V(kph)		
8	108 700.107	183 685.761	00°16'18" L	5,000.000	11.854	23.707	0.010	---	---	80		
9	158 538.970	183 545.656	09°27'18" L	300.000	24.609	49.506	1.020	---	---	80		
10	158 432.232	183 480.128	15°11'27" L	280.000	37.337	74.236	2.480	---	---	80		
11	158 240.664	183 423.891	05°05'03" L	650.000	28.858	57.678	0.640	---	---	80		

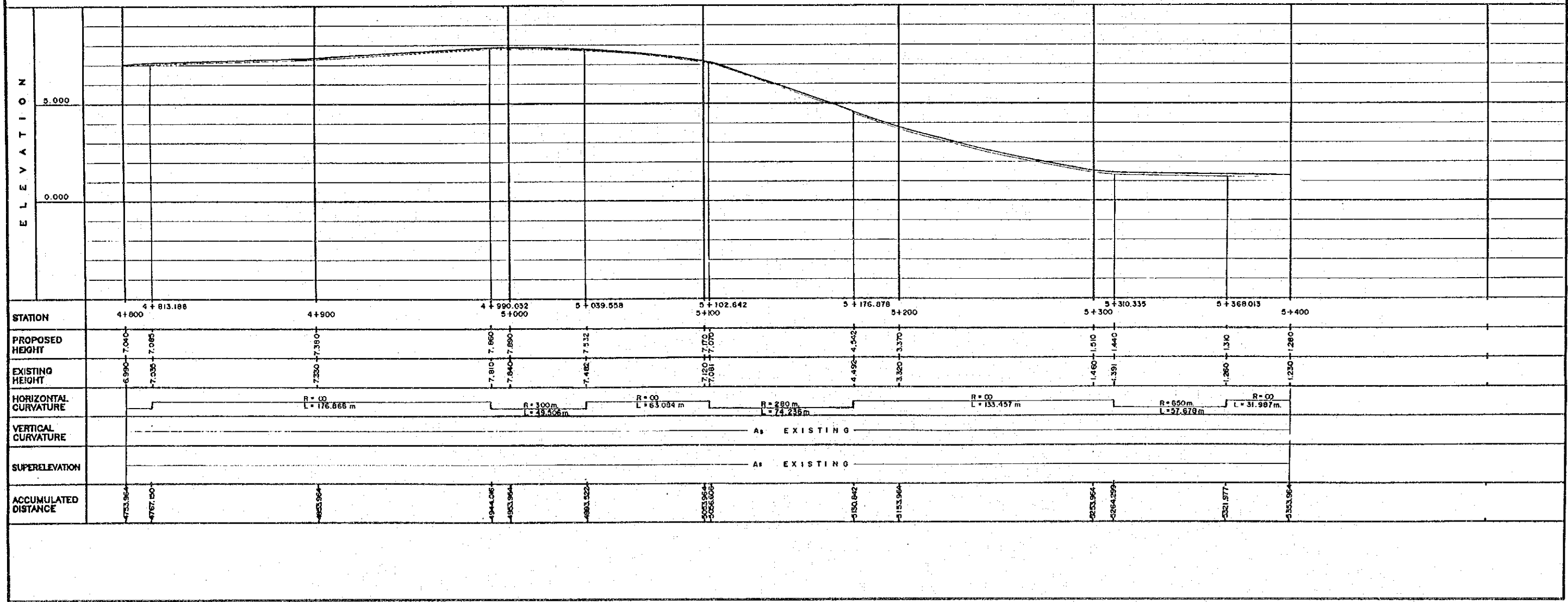

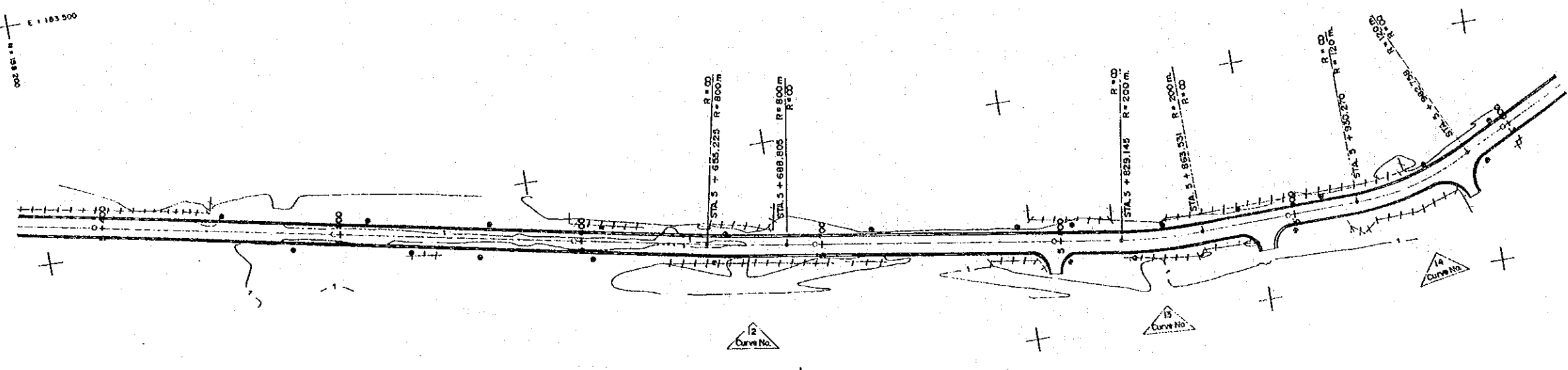

CURVE NO.	COORDINATES		ELEMENTS OF CURVES									
	NORTHING	EASTING	Def. Angle	Radius	T	Lo	E	e%	w	V(kph)		
12	157 914.246	183 358.804	02°24'10" L	800.000	16.793	33.580	0.180	Existing	-	80		
13	157 741.964	183 331.914	09°51'03" L	200.000	17.235	34.366	0.740	Existing	-	60		
14	157 631.335	183 333.806	25°03'40" L	120.000	26.671	52.466	2.930	Existing	-	60		

ELEVATION	STATION												
	5+400	5+500	5+600	5+655.225	5+688.803	5+700	5+800	5+829.145	5+863.531	5+900	5+930.270	5+992.756	6+000
PROPOSED HEIGHT	1.280	1.180	1.130	1.110	1.070	1.040	0.840	0.870	0.840	0.850	0.920	0.960	0.940
EXISTING HEIGHT	1.230	1.130	1.080	1.030	1.000	0.980	0.790	0.793	0.796	0.800	0.827	0.874	0.890
HORIZONTAL CURVATURE	R = ∞		R = 800m L = 33.580m			R = ∞ L = 140.340m		R = 200m L = 34.386m		R = ∞ L = 66.739m		R = 120m L = 32.488m	
VERTICAL CURVATURE	AS EXISTING												
SUPERELEVATION	AS EXISTING												
ACCUMULATED DISTANCE	5353.961	5433.961	5553.961	5609.186	5642.765	5653.961	5753.961	5783.105	5817.492	5853.961	5884.231	5936.719	5953.961