

添付資料-4

セミナー用教材

Appendix-4

1. Seminar on maintenance and inspection of thermal power plant (November, 1994)

Maintenance and Inspection of Thermal Power Plants

1. Introduction

2. Problems of Thermal Power Plants

- (1) Outline of Thermal Power Plant
- (2) Components and Parts to be damaged

3. Maintenance and Inspection in Japan

- (1) Types of Inspection and Typical Example
- (2) Changes of Maintenance Philosophy in Japan and
Concept of Preventive Maintenance

4. Importance of Maintenance and Inspection

- (1) Elongation of Equipment Life
- (2) Necessity for Manpower Training

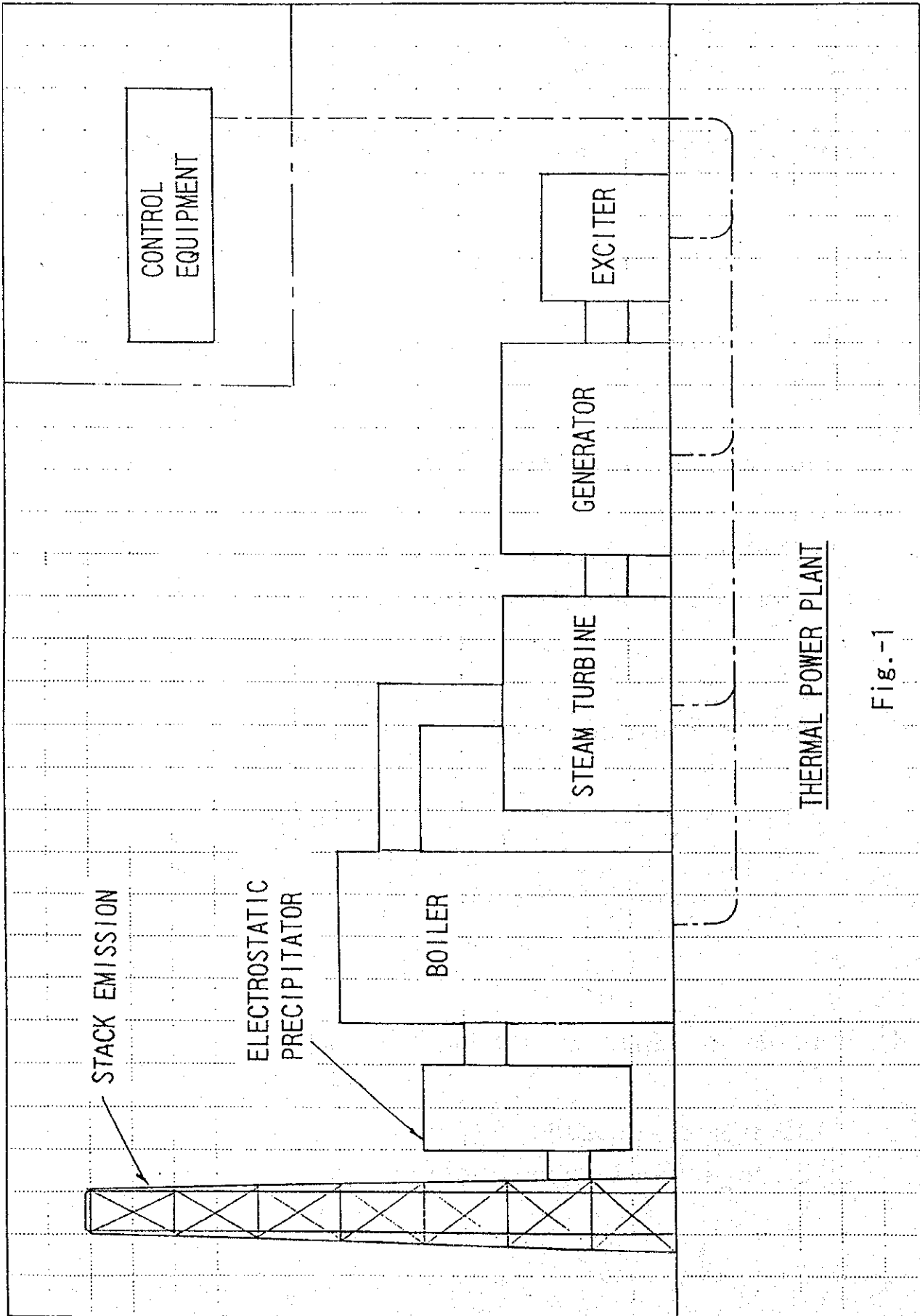

Fig.-1

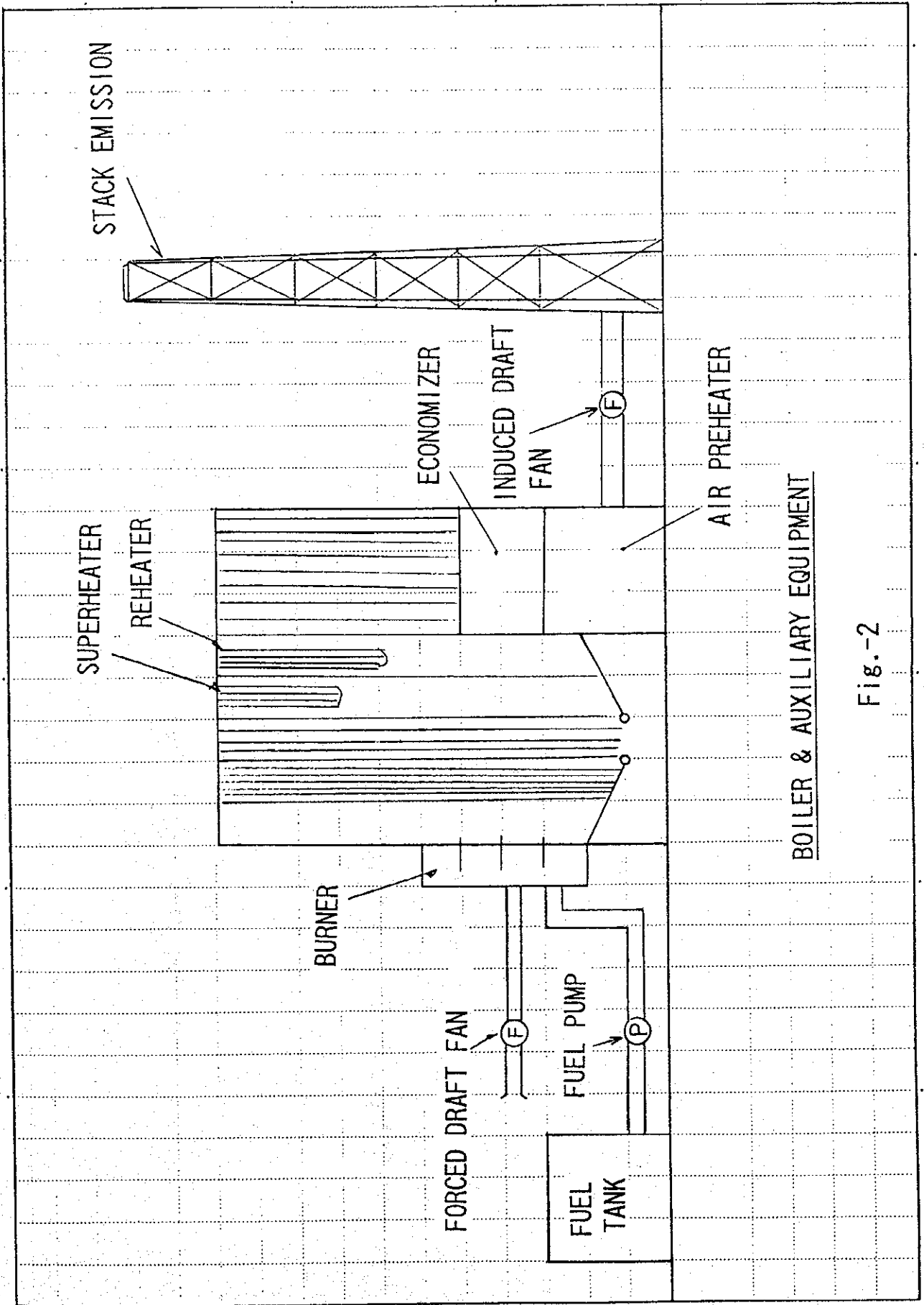
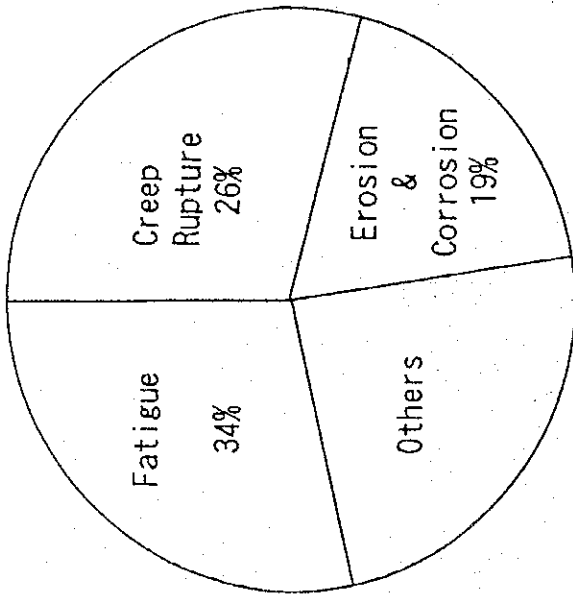
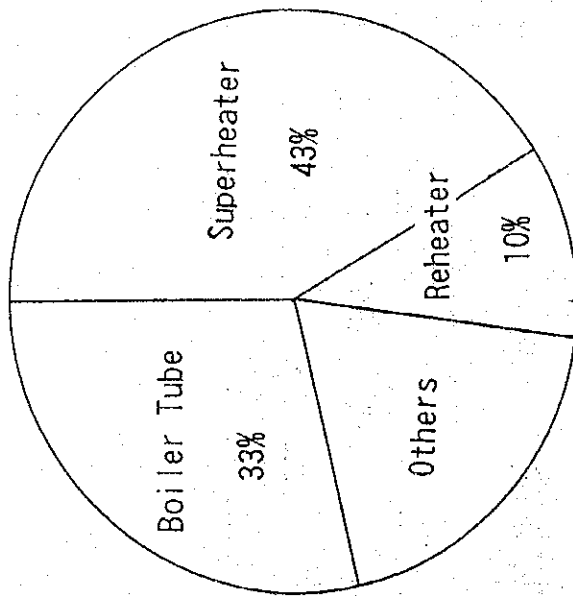

Fig.-2



CAUSES OF DAMAGE



COMPONENTS TO BE DAMAGED

DAMAGE OF BOILER (For 5-years statics in Japan)

Fig.-3

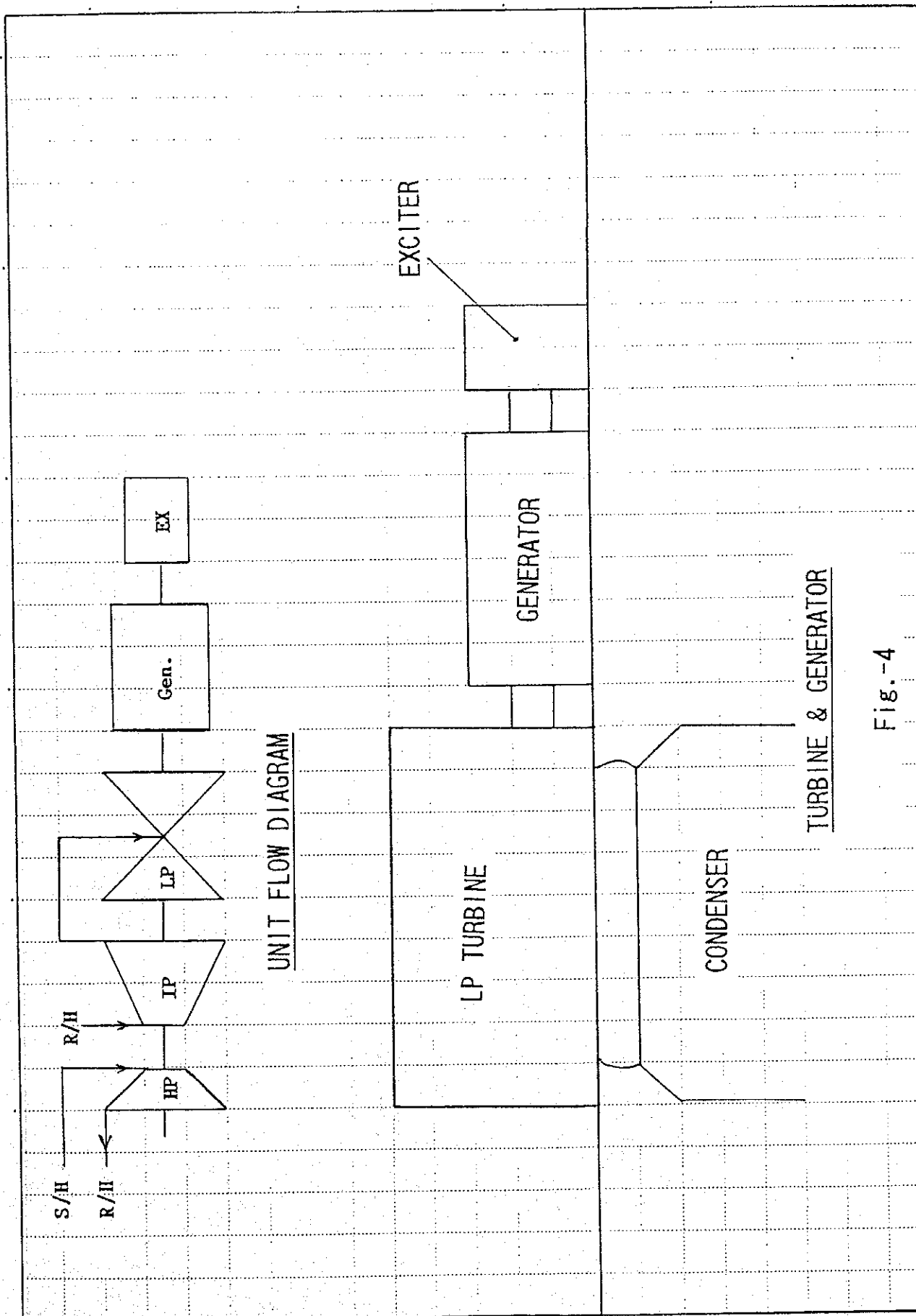
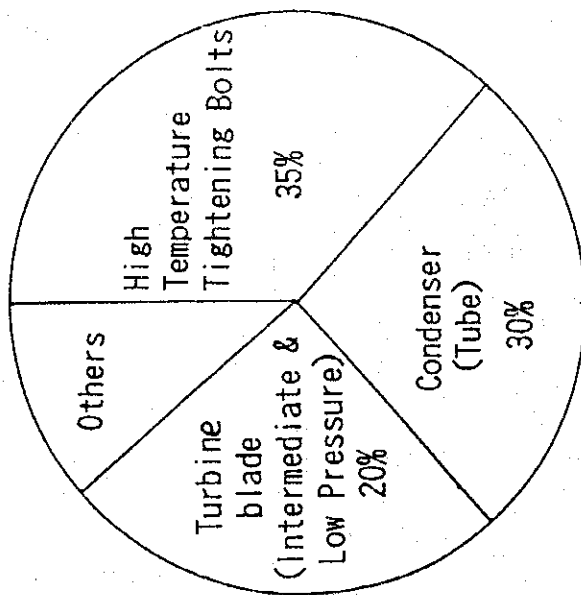
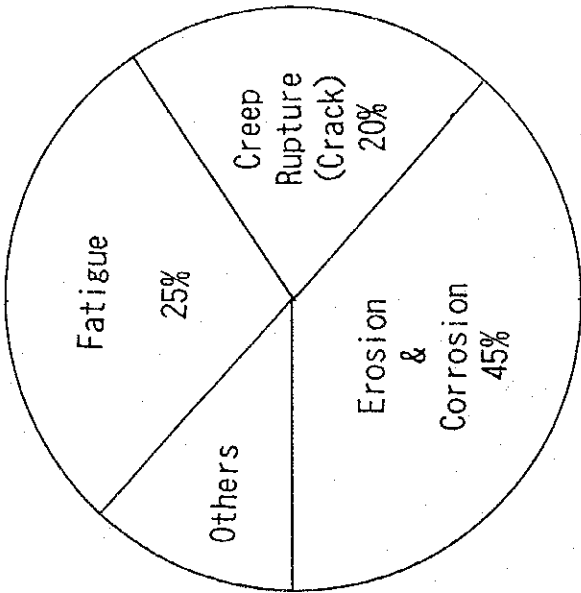

Fig.-4



COMPONENTS TO BE DAMAGED



CAUSES OF DAMAGE

TURBINE PARTS MOST FREQUENTLY REPLACED
(For 5-years statics in Japan)
Fig.-5

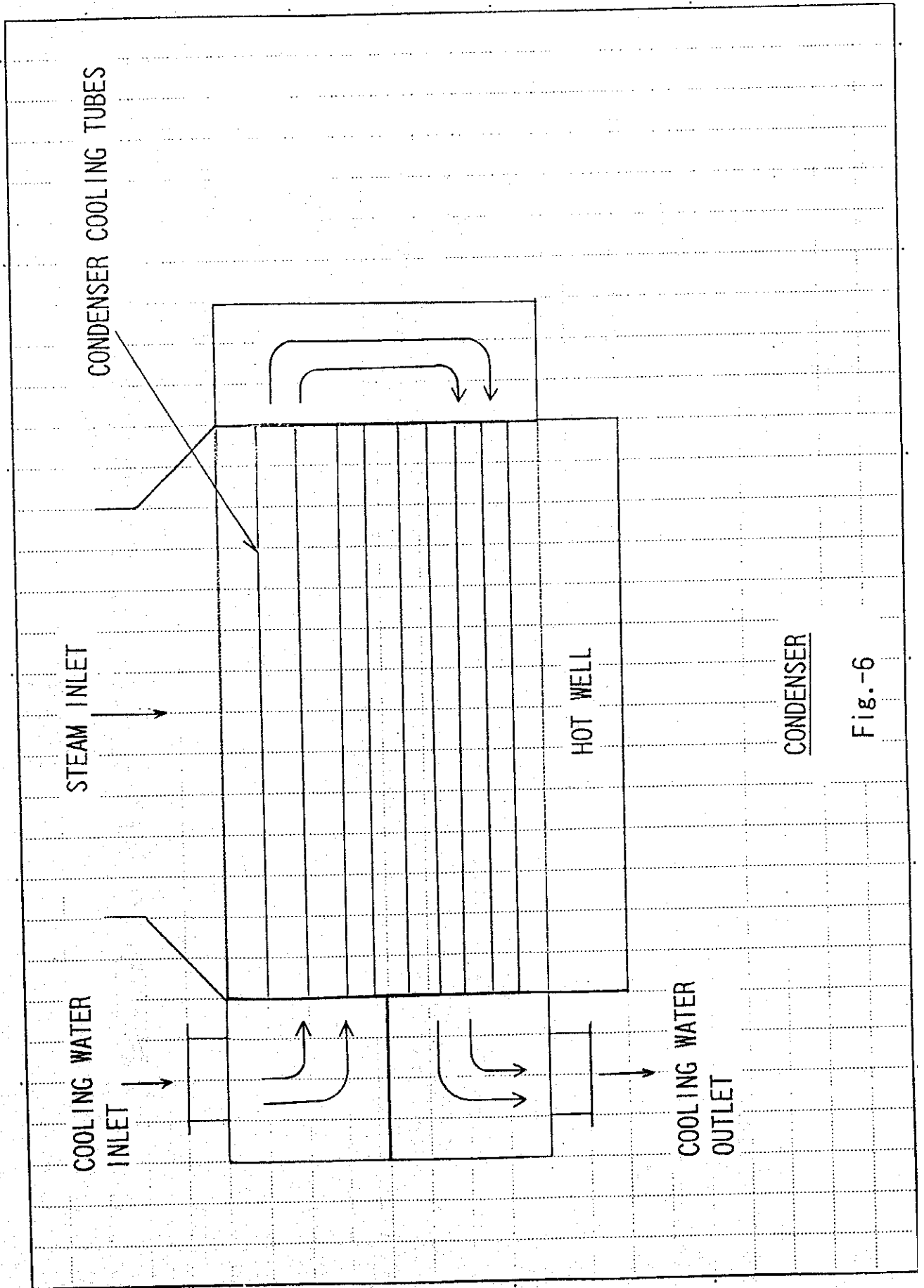

CONDENSER

Fig.-6

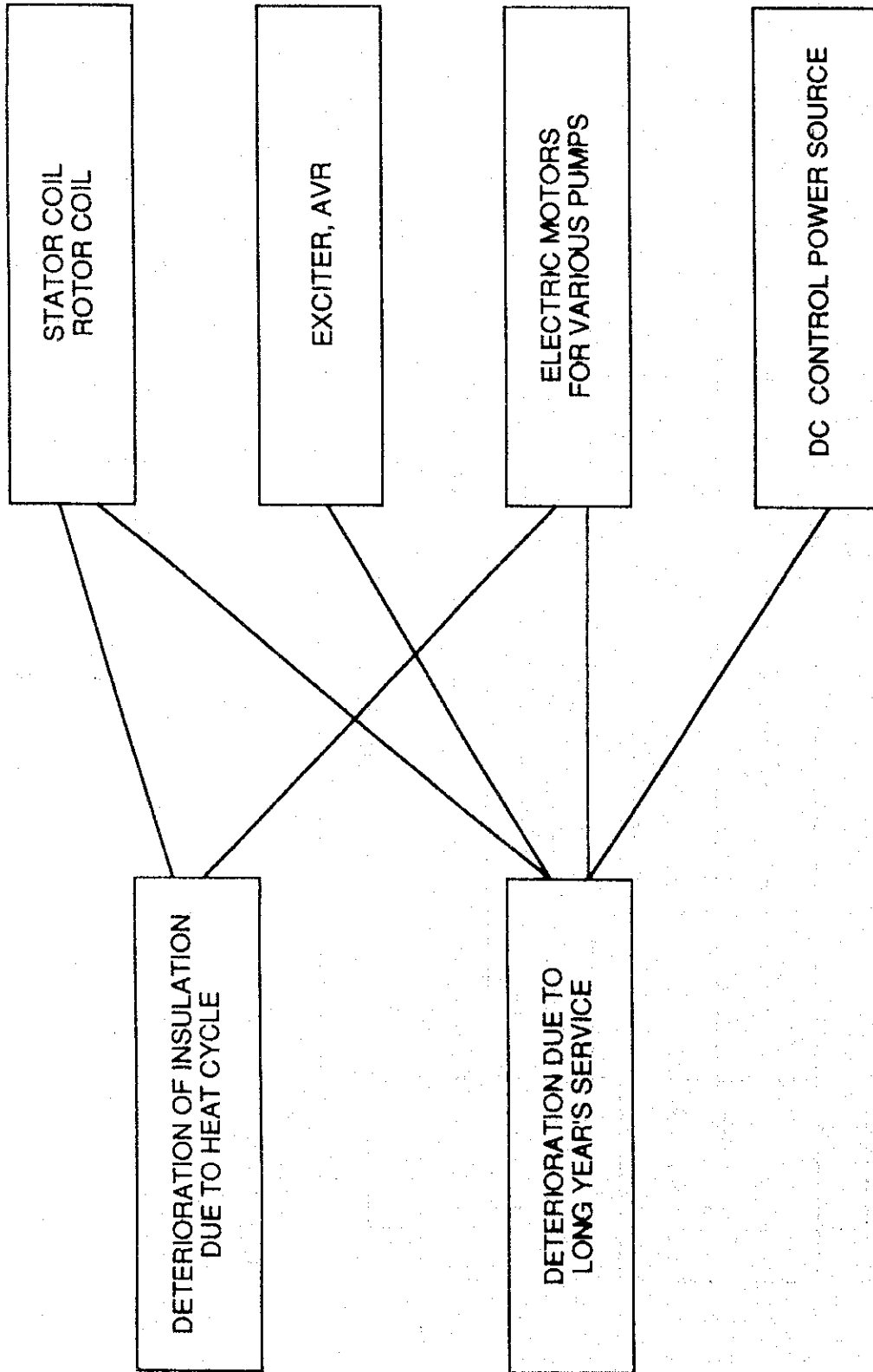

GENERATOR AND ELECTRICAL EQUIPMENT

FIG. 7

Table 8 (1/2)

Daily Operation Check Items (Boiler and Turbine)**1. Boiler**

- Steam pressure and temperature at outlet of pre-heater and re-heater
- Rate of evaporation and flow rate of water supply to boiler
- Water level inside drum
- Pressure inside drum
- Fuel used
- Steam temperature at pre-heater and re-heater
- Thermal efficiency of boiler

2. Turbine

- Generator output
- Pressure and temperature of main steam
- Revolution of steam turbine
- Exhaust pressure of steam turbine
- Pressure and temperature of extraction steam of steam turbine
- Oil pressure at bearing inlet
- Oil temperature at bearing outlet
- Control oil pressure of steam turbine
- Aperture of steam governor
- Vibration magnitude of steam turbine
- Efficiency of steam turbine
- Differential Elongation of Shaft and casing (for 2 or more compartment)

Table 8 (2/2)

Daily Inspection Items

<u>Equipment</u>	<u>Item</u>
• Safety Valve of Boiler	- steam leakage from seat
• Main Pipes	- abnormality of hanger unit - steam leakage from pipe - abnormal vibration of pipe
• Burner	- abnormal combustion - abnormality inside burner
• Rotating Parts	- abnormal vibration and/or noise - steam leakage from gland - abnormal oil temperature and/or oil level of bearings; oil leakage from bearings
• Main Valves	- abnormal vibration and/or noise of valve body - steam leakage from valve gland and/or valve seat - abnormal functioning
• Steam Turbine	- abnormal vibration and/or noise - steam leakage from casing - loose nuts and bolts - abnormal vibration and/or noise of bearings/abnormal heating or oil discharge
• Main Heat Exchanger, etc.	- steam leakage - abnormal water level

Table 9 (1/4)

CONTENTS OF PERIODICAL INSPECTION

COMPONENTS	INSPECTION CATEGORIES	INSPECTION METHODS	REMARKS
<u>I.Boiler</u>	Inspect and confirm the condition of following points:		
<u>1.Steam Drum and Flashtank</u>			
(1) Drum inner surface	(1) Crack,Corrosion and Erosion on welds	Visual inspection and liquified penetrant test.	Internal components shall be removed as much as that an inspection be possible at circumference joints, all around joints and horizontal joints.
(2) Internal components	(1) Crack,Corrosion and Erosion on welds (2) Sealing (3) Looseness and Burning on fixing bolts	Visual inspection and hammering diagnosis.	
<u>2. Water Drum</u>			
(1) Drum inner surface	(1) Crack,Corrosion and Erosion on welds	Visual inspection and liquified penetrant test.	Same as (1) drum inner surface.
(2) Internal components	(1) Corrosion,Crack and Deposit on screen-plates and orifice (2) Looseness and Burning on fixing bolts	Visual inspection and hammering diagnosis.	Remove screen plates.
<u>3.Furnace</u>			
(1)Evaporation Tubes	(1) Deposit, Accumulated particle on tube surface (2) Crack,Corrosion and Erosion on wall-tube surface (3) Deformation and alignment disorder (4) Abnormal phenomena on welds	Visual inspection.	Liquified penetrant test shall be given to welds of selected spacer lugs of tubes.
(2)Burner Throat			
(3)Header			
(4)Inner part of Housing			

Table 9 (2/4)

COMPONENTS	INSPECTION CATEGORIES	INSPECTION METHODS	REMARKS
<u>4. Superheater/Reheater/ Economizer</u> II <u>Safety Valve</u> III <u>Combustion Apparatus</u> IV <u>Air Preheater</u> V <u>Forced Draft Fan</u> <u>Induced Draft Fan</u> <u>Gas Recirculation Fan</u> <u>Gas Mixing Fan</u> VI <u>Boiler Circulation Pump</u> <u>Boiler Water Feed Pump</u>			

Table 9 (3/4)

COMPONENTS	INSPECTION CATEGORIES	INSPECTION METHODS	REMARKS
<p>I. <u>Steam Turbine</u></p> <p>1. <u>Casing</u></p> <p>(1) Flange surface</p> <p>(2) Inner and outer face</p> <p>(3) Bolts</p> <p>(4) Nozzle box</p> <p>2. <u>Rotor</u></p> <p>(1) Rotor and disc</p> <p>(2) Blade</p>	<p>Inspect and confirm the condition of following points.</p> <p>(1) Leakage, Erosion and Crack on surface</p> <p>(1) Deposit and Foreign Particle</p> <p>(2) Crack, Erosion and Cavity</p> <p>(3) Steam Leakage</p> <p>(1) Crack and Other Damage</p> <p>(2) Degradation on high temperature</p> <p>(1) Crack, Damage and Erosion</p> <p>(1) Crack, Damage, Erosion and Corrosion</p> <p>(2) Extent of Damage on journal and thrust collar</p> <p>(3) Existence of Vent on main shaft</p> <p>(4) Condition of ballance weight</p> <p>(1) Crack, Erosion and Corrosion</p> <p>(2) Crack on racing wires and shroud rings</p> <p>(3) Existence of Floating Gaps on end-blade</p> <p>(4) Looseness of shroud ring and blade inlet</p>	<p>Visual inspection. Magnetic particle test or liquified penetrant test according to the need.</p> <p>Visual inspection. Magnetic particle test or liquified penetrant test according to the need.</p> <p>Visual inspection and measuring of hardness.</p> <p>Visual inspection. Magnetic particle test and liquified penetrant test according to the need.</p> <p>Visual inspection. Magnetic particle test and liquified penetrant test according to the need.</p> <p>Visual inspection. Magnetic particle test and liquified penetrant test according to the need.</p> <p>Visual inspection. Magnetic particle test and liquified penetrant test according to the need.</p>	

Table 9 (4/4)

COMPONENTS	INSPECTION CATEGORIES	INSPECTION METHODS	REMARKS
(3)Diaphragm	(1) Crack,Erosion and Damage (2) Wear,Deformation and Damage	Visual inspection. Magnetic particle test and liquified penetrant test according to the need.	
(4)Bearing journal and bearing box			
3. <u>Gland</u>			
II <u>Main valve</u>			
III <u>Governor Mechanism & Emergency Shoudown Mechanism</u>			
IV <u>Oil System & Oil Cooler</u>			
V <u>Condenser</u>			
VI <u>Condenser Appurtenances</u>			
VII <u>Feed Water Heater</u>			

350MW Class Boiler and Turbine

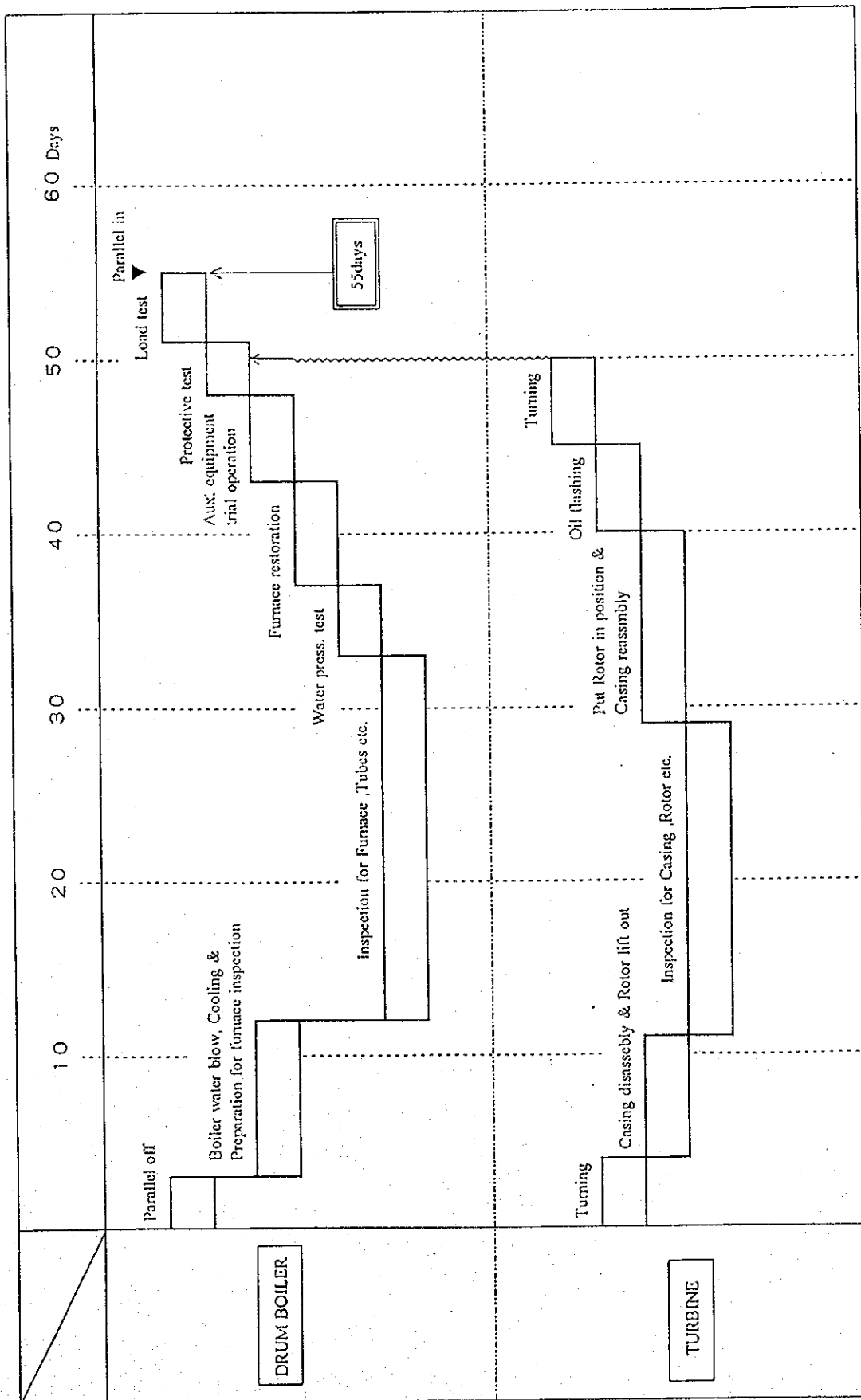

TYPICAL INSPECTION SCHEDULE

Causes of damage to boiler pressure parts;

- 1) Creep
 - 2) Fatigue
 - 3) Corrosion and Erosion
- Failures occurred independently or by a combination such as stress corrosion crack and corrosion fatigue.

To analyse the cause of failure and ascertain a proper diagnosis is critical.

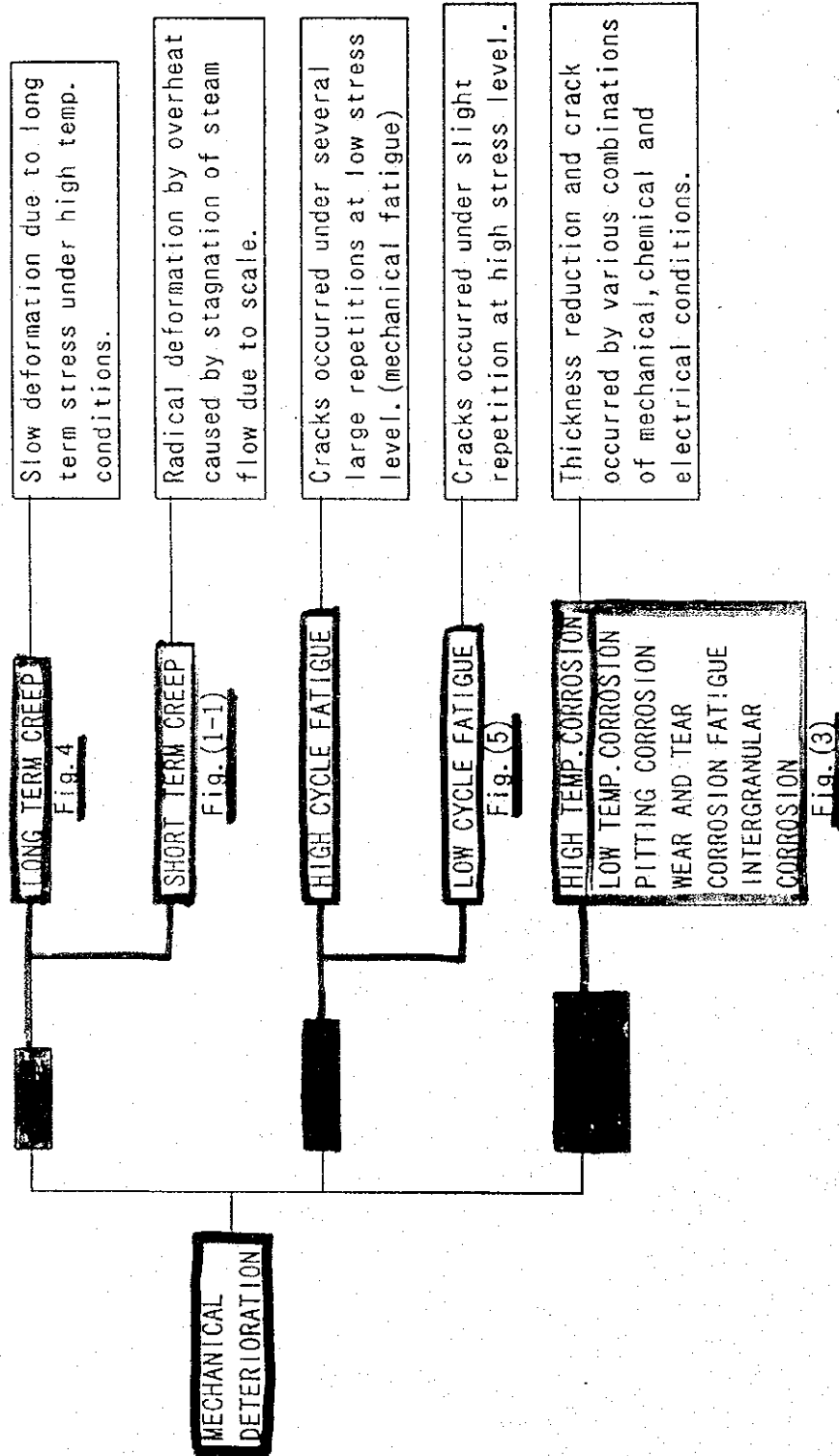

FIG. B-1 DAMAGE FACTORS OF DETERIORATION

Causes of damage to boiler pressure parts;

- 1) Creep
 - 2) Fatigue
 - 3) Corrosion and Erosion
- Failures occurred independently or by a combination such as stress corrosion crack and corrosion fatigue.

To analyse the cause of failure and ascertain a proper diagnosis is critical.

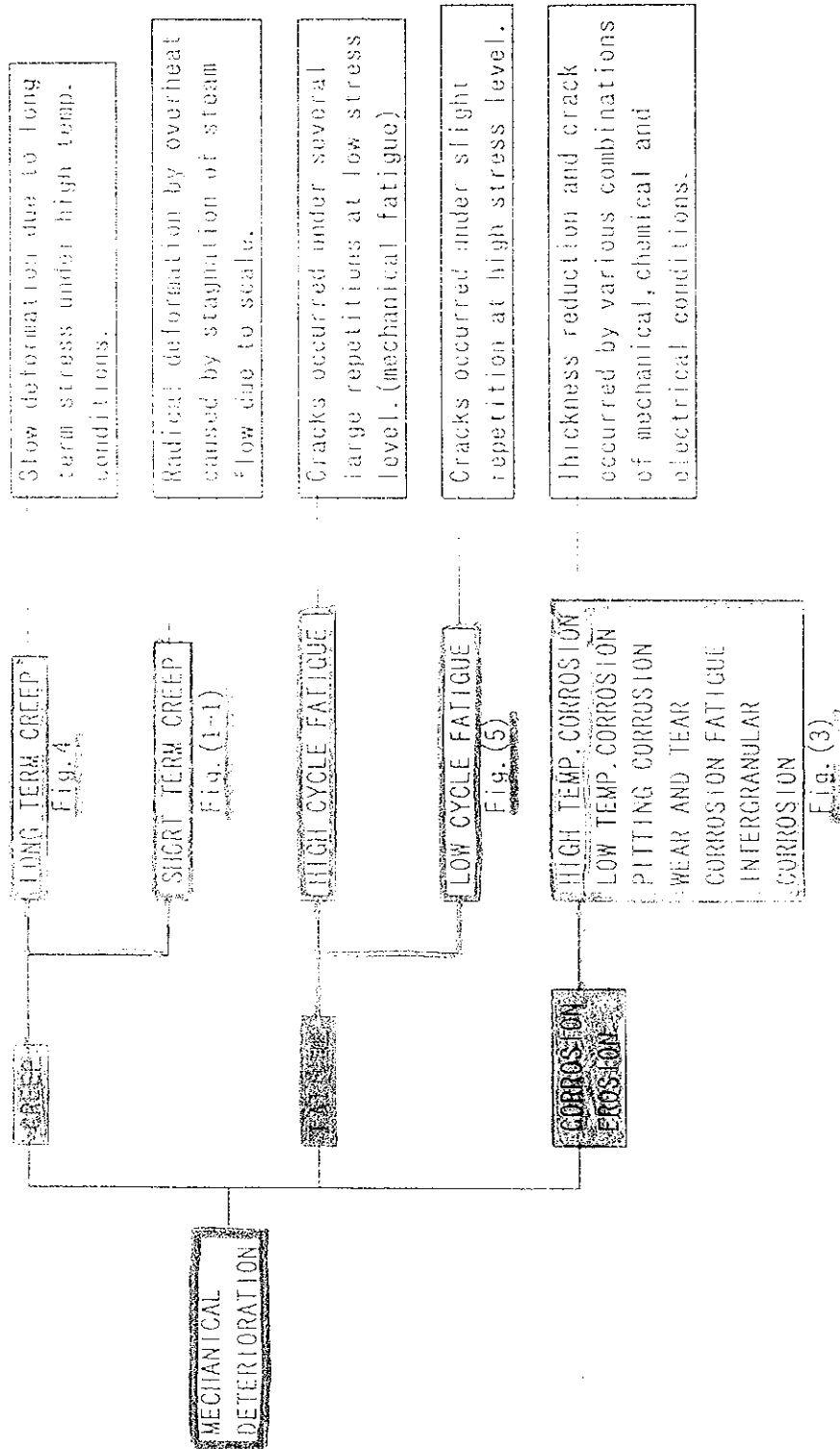
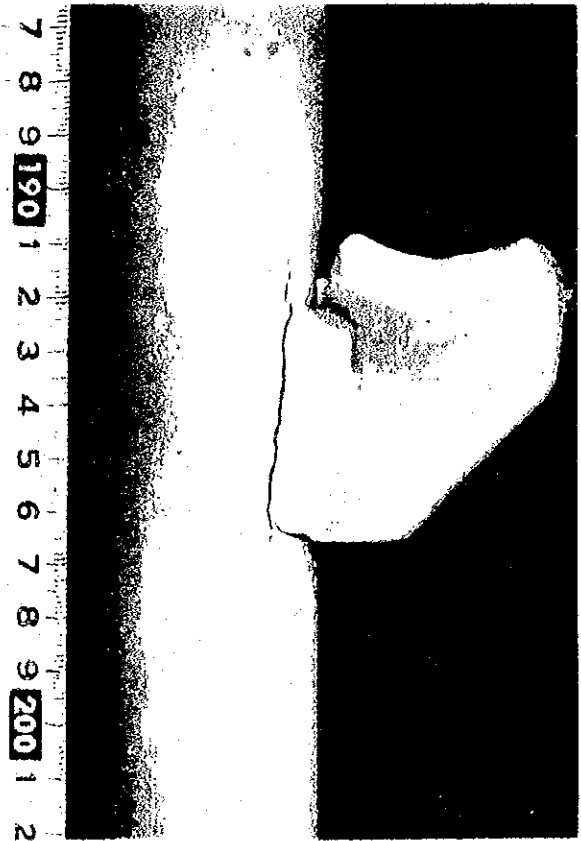
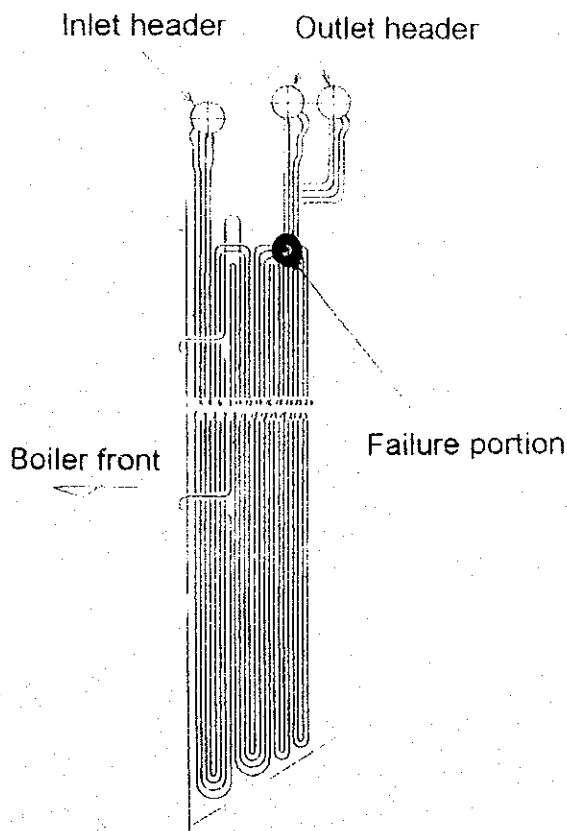

FIG. B-1 DAMAGE FACTORS OF DETERIORATION

FIG. B-2

Example : Long Term Creep Rupture
Location of Failure : Weld Portion between Superheater Tube and Support Lug
Type of Boiler / Fuel : Once-Through Boiler / Heavy Oil
Cause : Long Term Creep Rupture
Time of Failure Occurrence : 21 Years After Commercial Operation



Appearance of failure portion



Microphotograph of 400 magnifications

FIG. B-3

Example : Short - term Overheating
Location of Failure : Between Burner Openings Level as illustrated below .
Type of Boiler / Fuel : Natural circulation / Heavy Oil .
Cause : Overheating due to tube inside scale .
Time of Failure Occurrence : 18 years after Commercial Operation

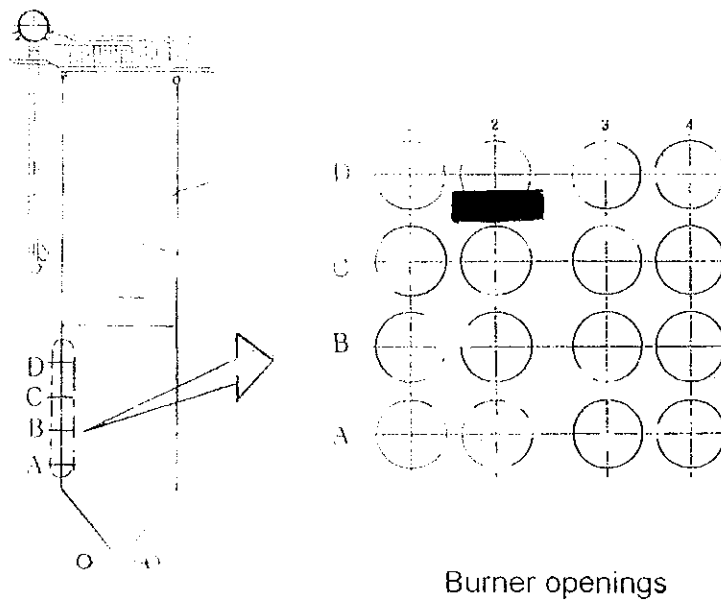

Location of Failure ()



Appearance of Tube swelling



Fire side Insulation side

Situation of Tube inside Scale deposit

FIG. B-4

Example : Low Cycle Fatigue
Location of Failure : Weld Portion between Reheater Outlet Header and Tube Stub.
Type of Boiler / Fuel : Natural Circulation Boiler / Heavy Oil and LNG.
Cause : Low Cycle Fatigue due to Thermal Stress
Time of Failure Occurrence : 19 Years After Commercial Operation

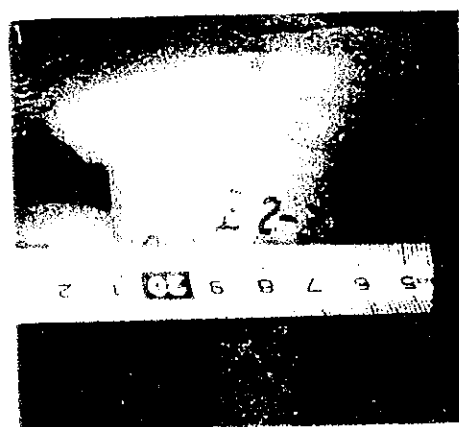
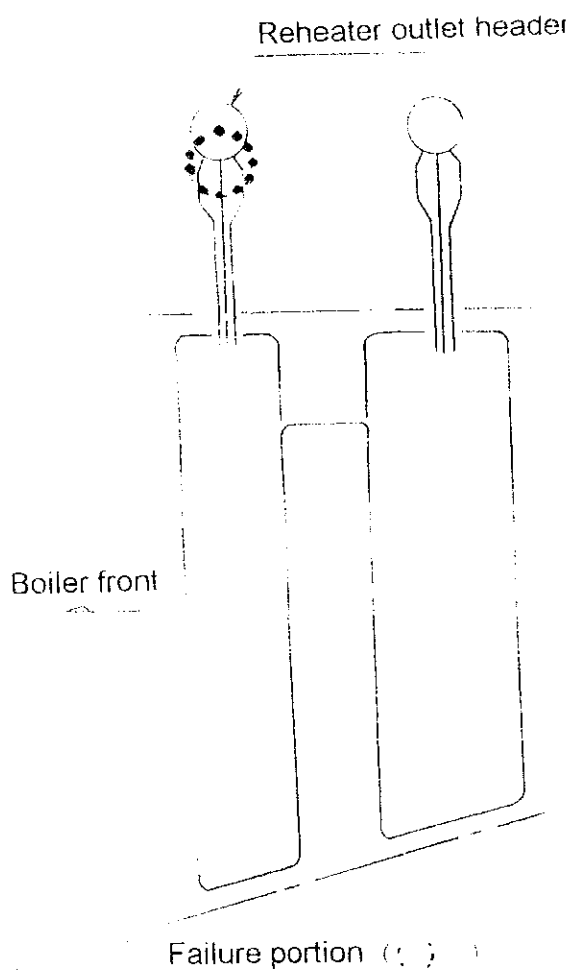

Appearance of Failure portion

FIG. B-5

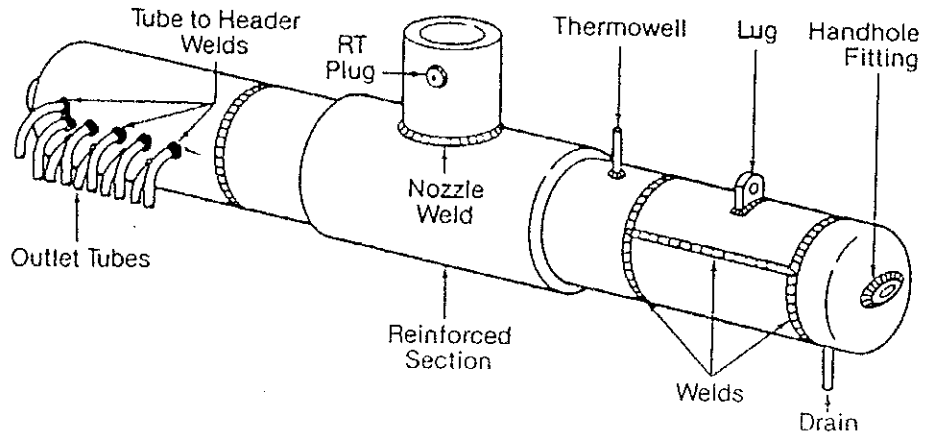

Header locations susceptible to cracking.

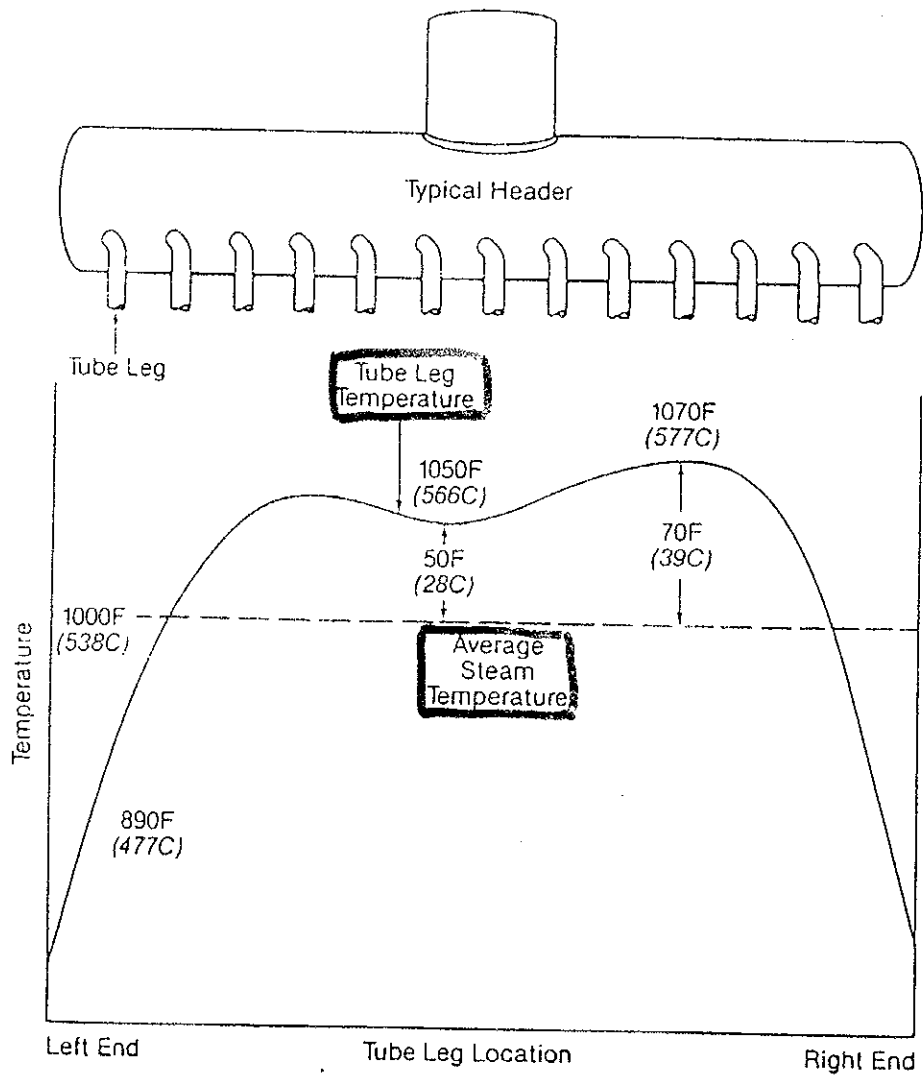

Steam temperature variation in a header.

FIG. B-6

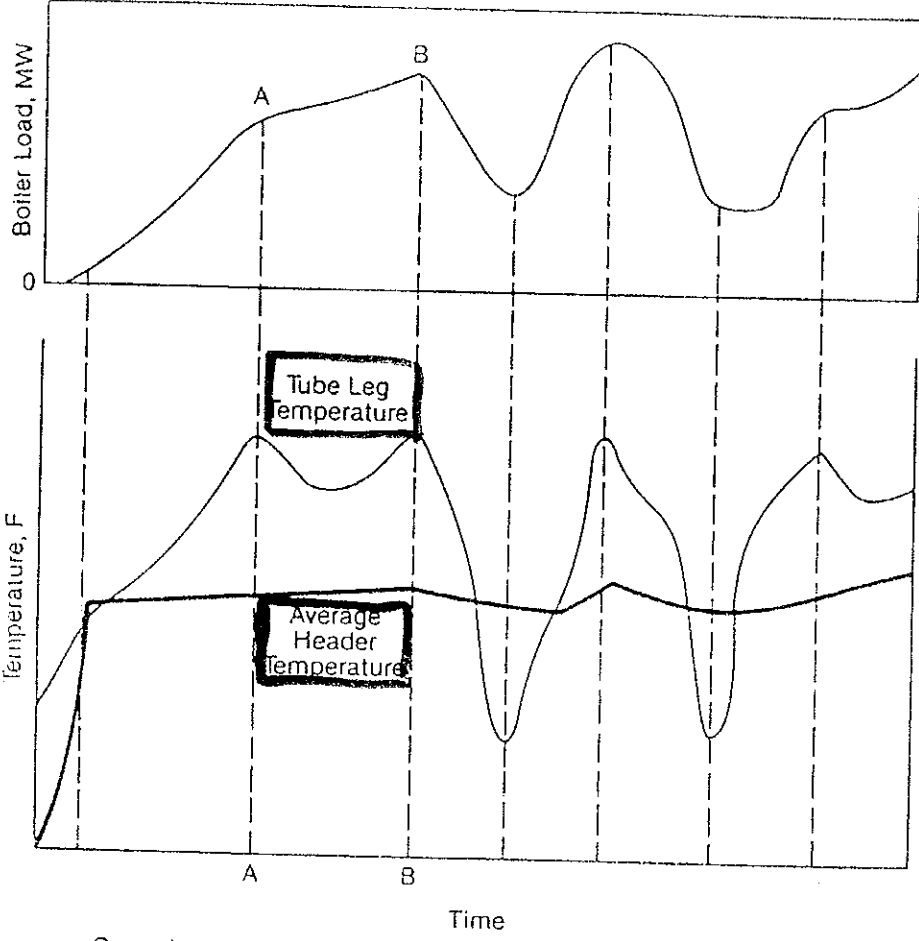

Superheater tube leg temperatures vary with load.

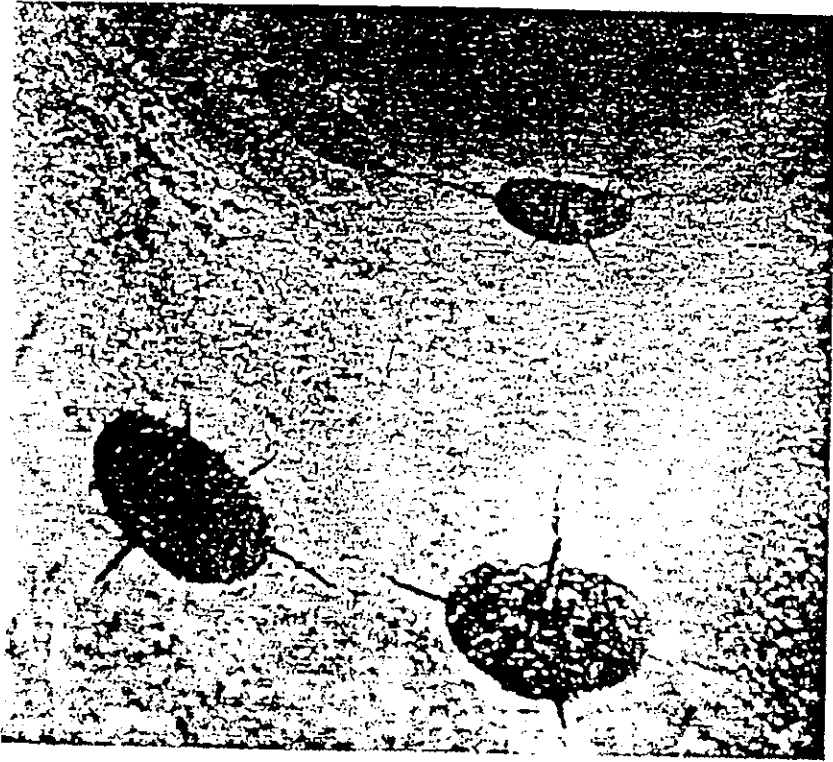

Large ligament cracks on header ID.

FIG. B-7

Example : Superheater. Reheater Tube High Temperature Corrosion .
Location of Failure : Reheater Tube as Illustrated below
Type of Boiler / Fuel : Once through Boiler / Heavy Oil .
Cause : High Temperature Corrosion Due to Tube Outside Scales
(Vanadium , Sodium and Sulfur) .
Time of Failure Occurrence : 16 Yeas after Commercial Operation

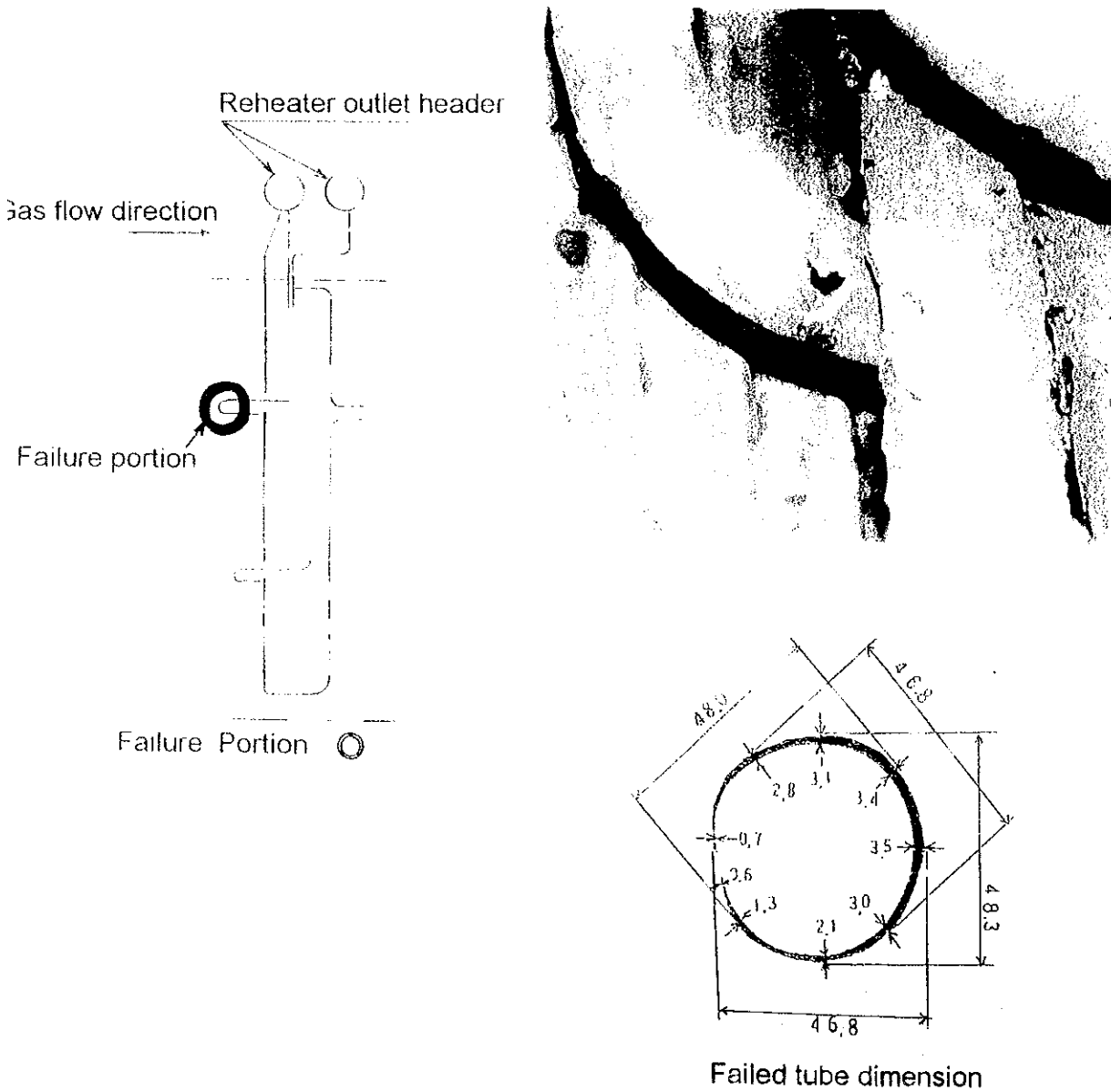
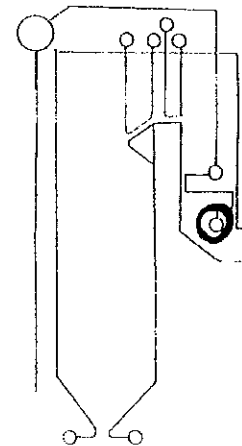
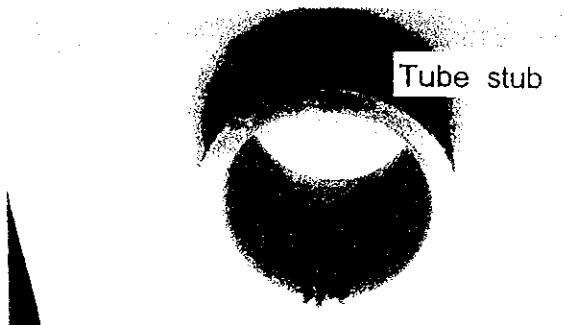

FIG. B-8

Example : Tube Stub Internal Crack
Location of Failure : Economizer Inlet Header
Type of Boiler / Fuel : Natural Circulation Boiler / Heavy Oil
Cause : Corrosion Fatigue
Time of Failure Occurrence : 13 Years After Commercial Operation



Failure Portion ()



Appearance of internal crack

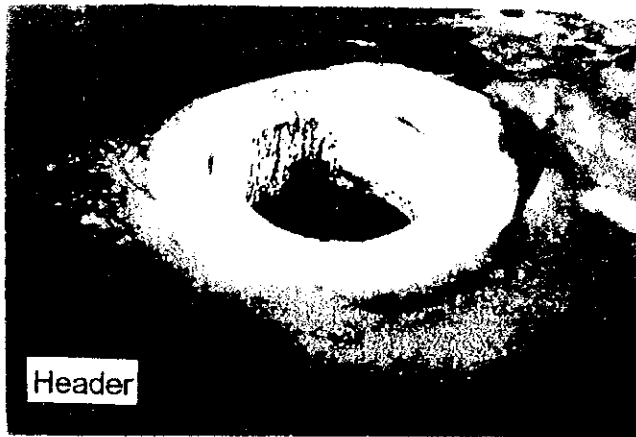

Macrograph of 5 magnification:



Micrograph of 100 magnification:

FIG. B-9

Example : Thermal Shock
Location of Failure : Reheater Attenuator.
Type of Boiler / Fuel : Once Through Boiler / Heavy Oil
Cause : Repeated Thermal Shock
Time of Failure Occurrence : 7 Years After Commercial Operation



Appearance of crack

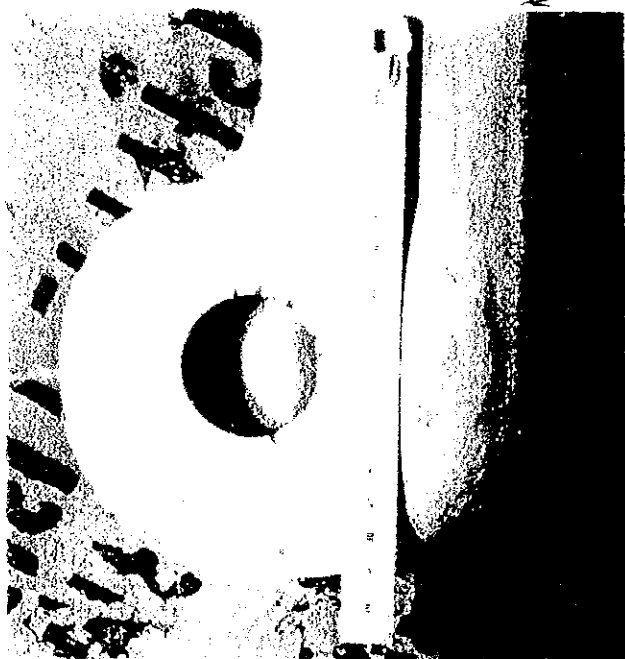
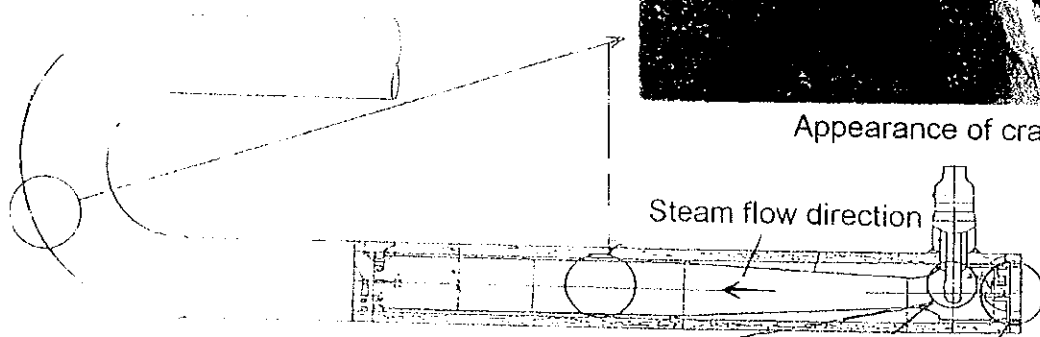

Crack of spray nozzle

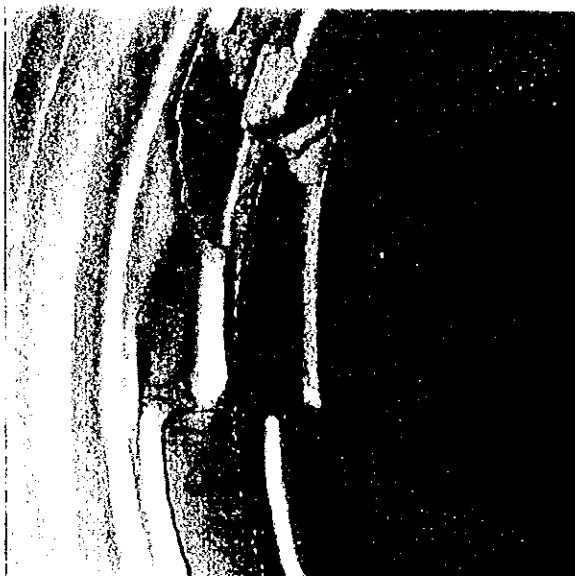
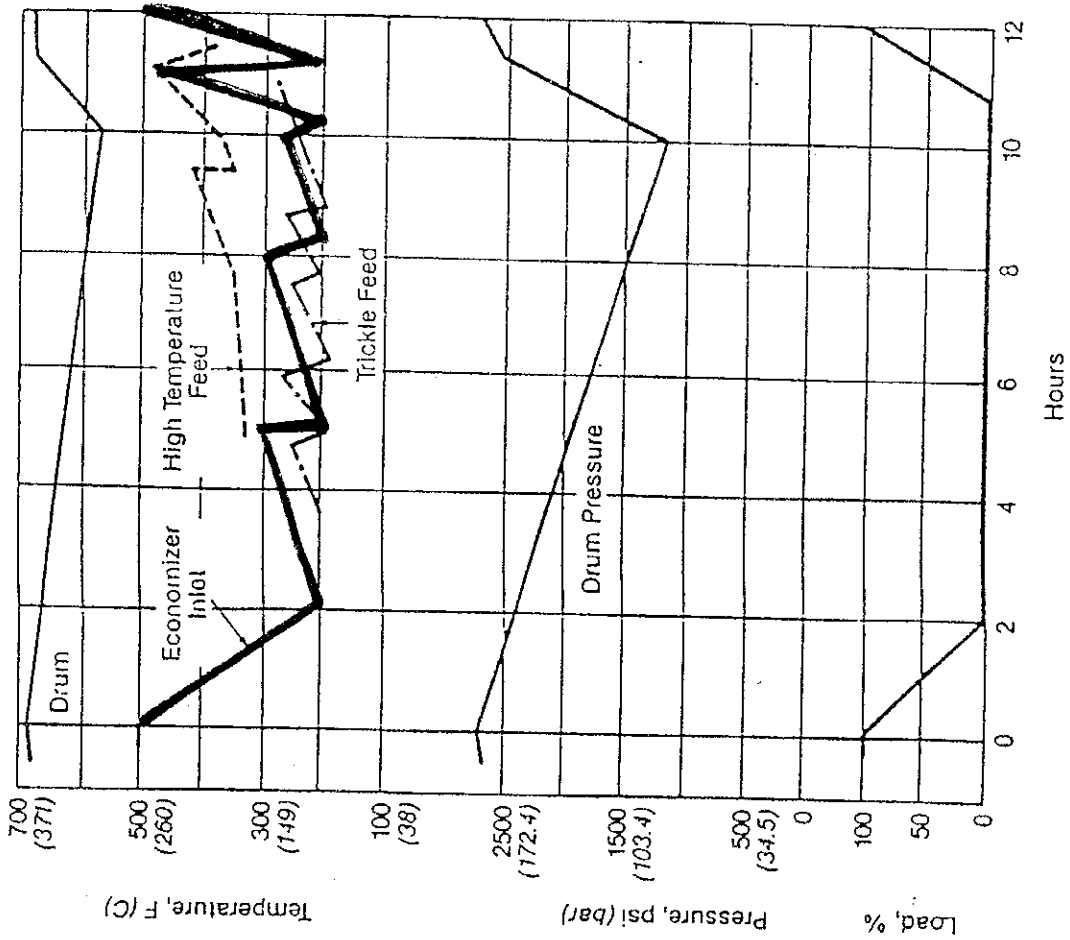
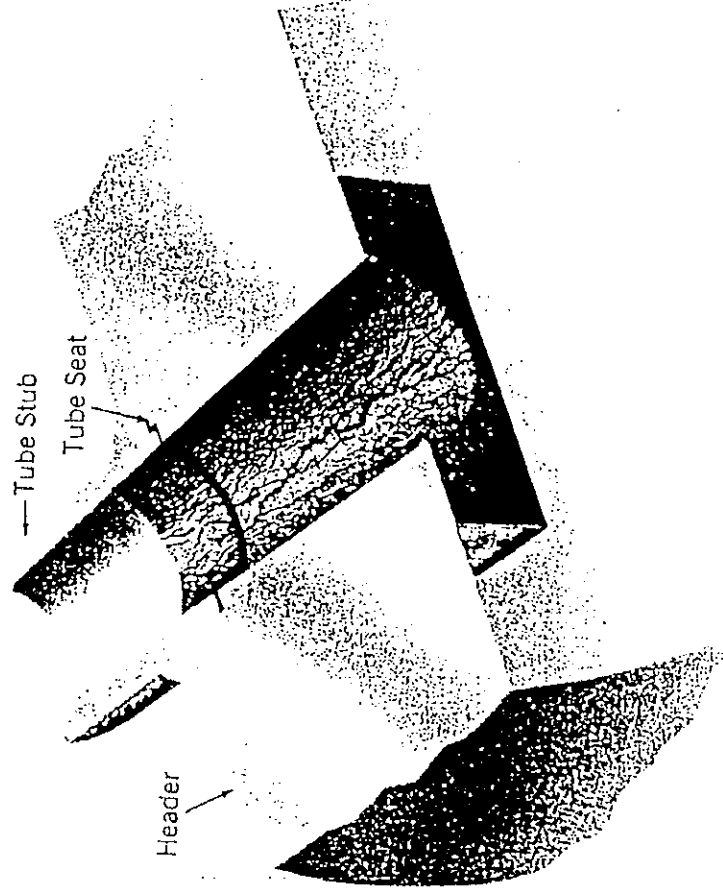

FIG. B-10



Economizer temperatures during overnight shutdown cycles.



Cracking in economizer inlet header occurs first in bore holes nearest water inlet.

FIG. B-11

Characteristic of weekday load
anticipated by Tokyo Electric Power Co. Inc.

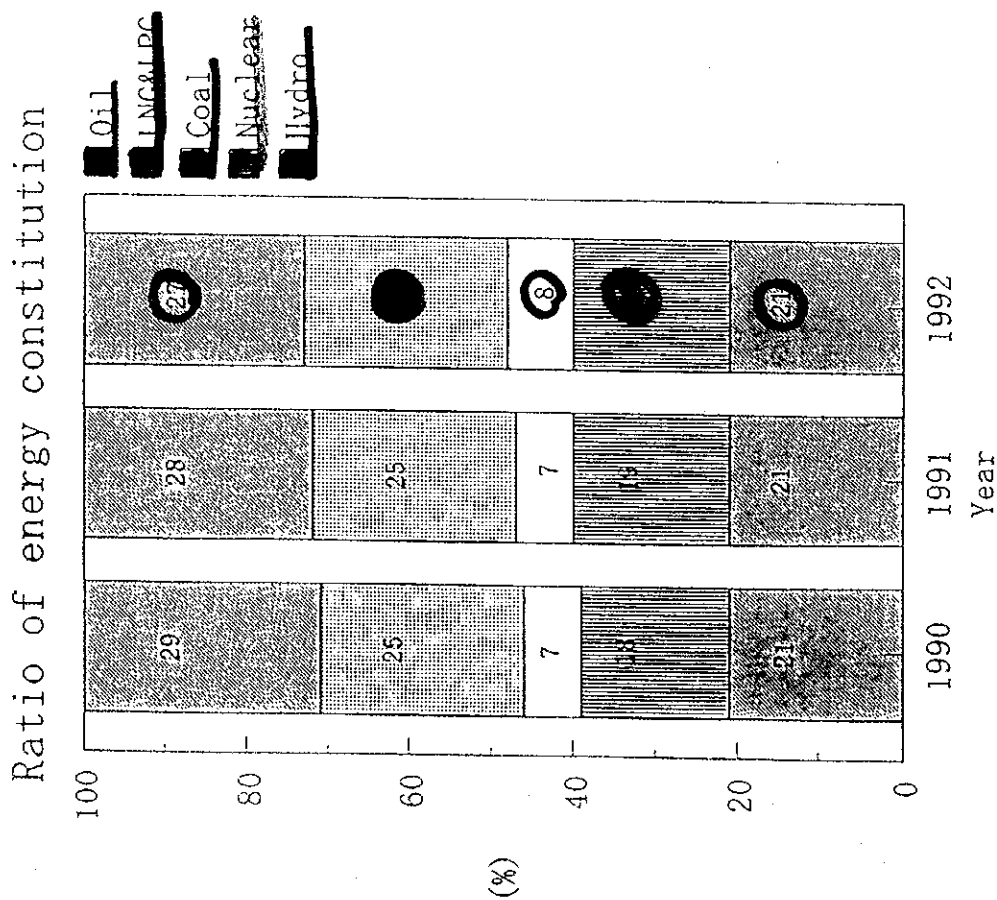
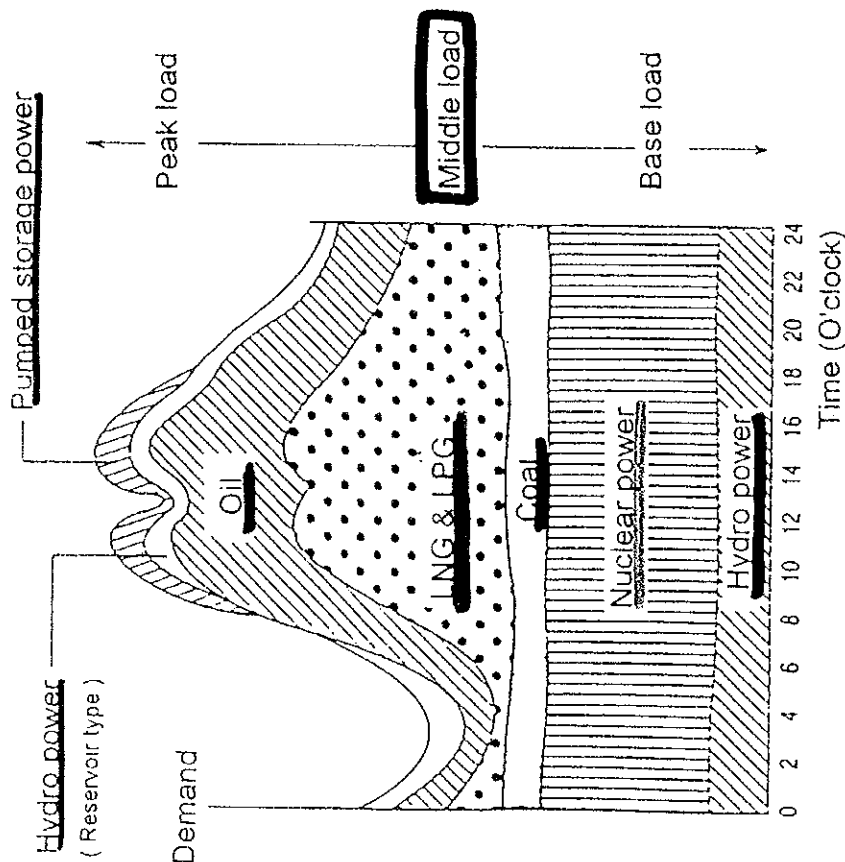

TURBINE COMPONENTS

Fig.:T-1

- Damage example : Cracks on shroud
- Damaged part : Extended from tenon holes upto shroud edge
- Caused by : Low cycle thermal stress fatigue and stress concentration
- Measures taken : (1)As an emergency measure the blade-shoulder(top) shall be filed off to reproduce a tenon and replace the shroud. Repaired blades and shrouds will be replaced with new ones at next periodical inspection.

Note:

In the worst case, it may lead to serious accident that the shrouds may come off from the tenon and are dispersed in splinters.

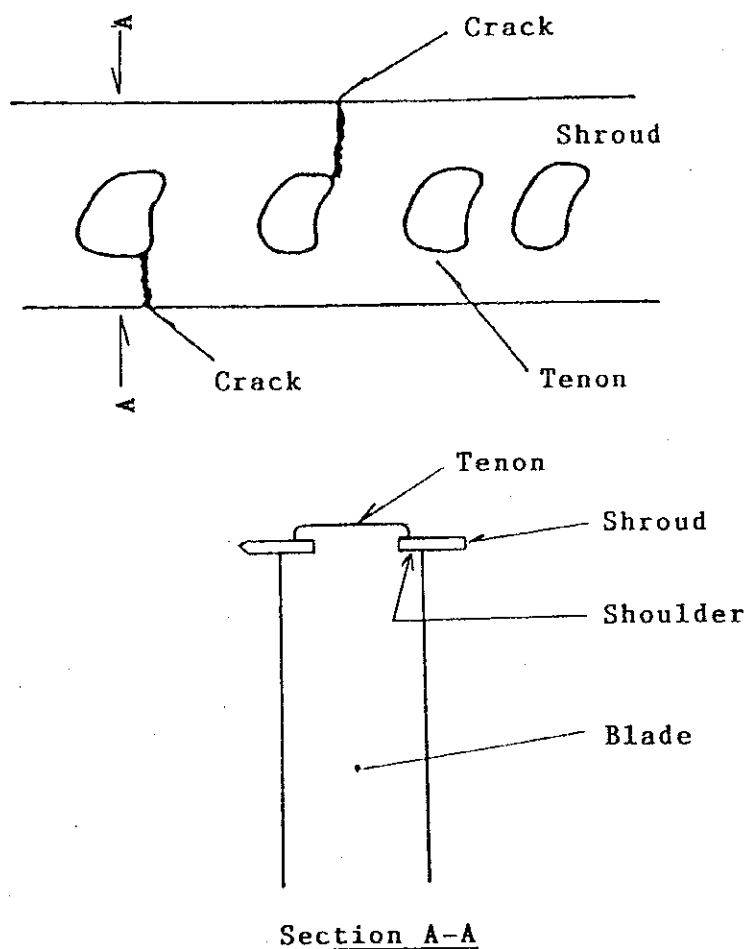

TURBINE COMPONENTS

Fig.:T-2

- Damage example : Erosion and Cracks on last-stage blades
- Damaged part : Shield plate of last-stage blades
- Caused by : Spray water controlling the exhaust temperature and condensed drain produced due to lower degree of vacuum
- Measures taken : (1)Cracks extended upto base metal: The blade shall be replaced with new one.
 (2)Extent of erosion within shield: Replace the shield plate. plate thickness.

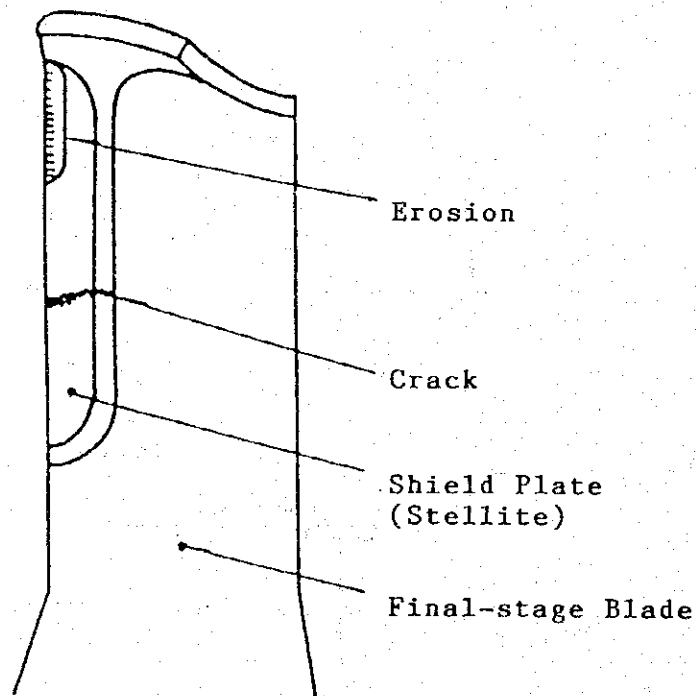

TURBINE COMPONENTS

Fig.:T-3

- Damage example : Cracks on reheat steam chamber
- Damaged part : In the corner of inlet on upper-half of reheat steam chamber of midium pressure casing
- Caused by : Thermal stress fatigue and stress concentration
- Measures taken : Radius,12m/m,in the corner at the inlet shall be modified to 25m/m.

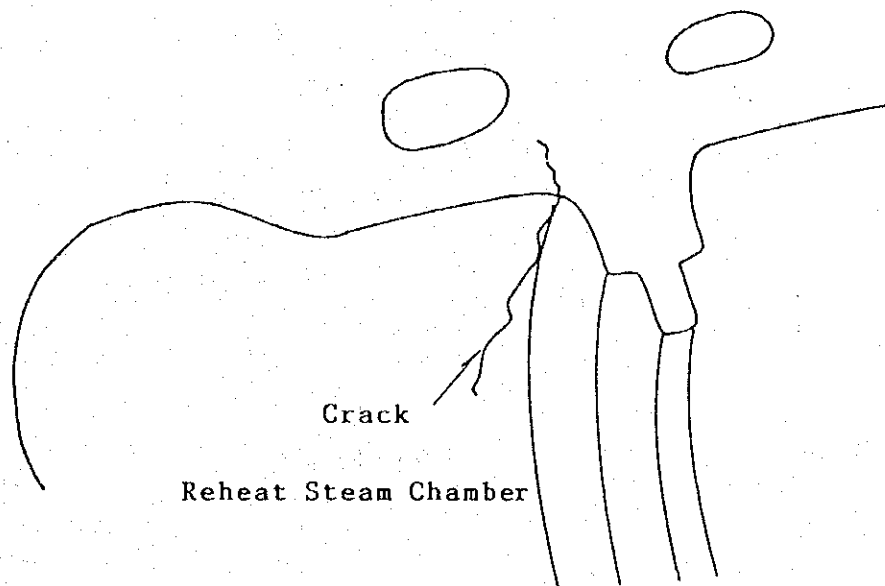

TURBINE COMPONENTS

Fig.:T-4

- Damage example : Cracks on nozzle plates of high/medium nozzle diaphragm
- Damaged part : Inner ring side nozzle plates of steam outlet
- Caused by : Aged-creep due to long term operation under high temperature.
- Measures taken : As an emergency measure, it can be repaired with cladding welding and it shall be replaced with new one later on as a permanent measure.

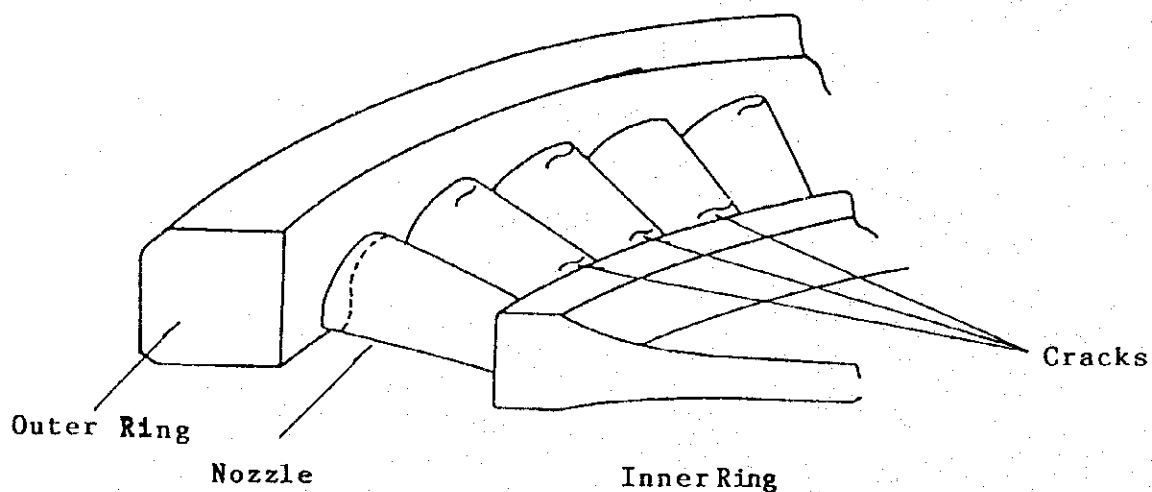

Appendix-4**2. Seminar on rehabilitation and maintenance proposals for selected power plants
(March, 1995)****Seminar Materials**

1. Introduction
 - 1.1 Power Supply Situation in Syria
 - 1.2 Method of Peak Demand Forecast
 - 1.3 Definition of Available Capacity and Guaranteed Capacity
 - 1.4 Peak Power Demand and Guaranteed Supply Capacity
 - 1.5 Power Supply and Demand Balance in Syria (Case 1)
 - 1.6 Power Supply and Demand Balance in Syria (Case 2)
2. Regarding Boilers
 - 2.1 Causes of Unit Declined Output, Declined Efficiency and Countermeasures in HFO Fired Unit
 - 2.2 Basic Concept for Boiler Rehabilitation Proposal
 - 2.3 Boilers are Human-beings
 - 2.4 Recommendation on Maintenance
 - 2.6 Rehabilitation Master Time Schedule
 - 2.7 Rehabilitation Master Schedule
 - 2.8 Inspection Items on Pressure Parts for Unit Nos. 1 & 2 in Banias P.S.
 - 2.9 Other Inspection Items (Banias P.S.)
 - 2.10 Inspection Items on Pressure Parts for Unit Nos. 1 & 2 in Mehardeh P.S.
 - 2.11 Other Inspection Items (Mehardeh P.S.)
 - 2.12 Inspection Items on Pressure Parts for Unit No. 6 in Katteneh P.S.
 - 2.13 Other Inspection Items (Katteneh P.S.)
 - 2.14 Liquid Penetrant

- 2.15 Magnetic Particle
- 2.16 Ultrasonic
- 2.17 Replication
- 2.18 Example of Tube Life Evaluation
- 2.19 Sample Tube Analysis
- 2.20 Non Destructive Method for Residual Life Diagnosis
- 2.21 Mechanism of Hydrogen Damage
- 2.22 Ultrasonic Method to Detect Hydrogen Damage
- 2.23 Damaged Portion due to Hydrogen Attack and Replaced area in Furnace Wall
- 2.24 Chemical Cleaning/ Condenser Tube Failure
- 2.25 Fuel Oil Ash Trouble
- 3. Regarding Turbines
 - 3.1 Inspection on Turbine Casings (Fig. T-1)
 - 3.2 Inspection on Turbine Casings (Fig. T-2)
 - 3.3 Inspection on Tightening Bolts at HIGH Temperature Area (Fig. T-3)
 - 3.4 Inspection on Nozzle Plates of High/Medium Nozzle Diaphragm (Fig. T-4)
 - 3.5 Inspection on Turbine Blades (Fig. T-5)
 - 3.6 Inspection on Turbine Blades (Fig. T-6)
 - 3.7 Inspection on Turbine Rotor Heat Group (Fig. T-7)
 - 3.8 Inspection on Turbine Rotor Center Bore (Fig. T-8)
 - 3.9 Main Stop Valve (Fig. T-9)
 - 3.10 Feed Water Heater (Fig. T-10)
 - 3.11 High Pressure Turbine (Dwg. T-1)
 - 3.12 Medium Pressure Turbine (Dwg. T-2)
 - 3.13 Low Pressure Turbine (Dwg. T-3)

POWER SUPPLY SITUATION IN SYRIA

Up to 1993 - Daily Power Outage

1993 to 1994 - Tishreen and Jandar GT Started

1995

- Situation Greatly Improved
- Very Few Outage in Damascus
- Completion of Tishreen GT and Jandar C/C

1995 ~ - Aleppo, El Zara, Etc.

Method of Peak Demand Forecast

1) Peak demand; the following rates of increase are used based on the peak demand of 2,500 MW in 1994.

- 1995 - 2000 rate of increase : 9%/year
- 2001 - 2005 rate of increase : 7%/year
- 2006 - 2010 rate of increase : 6%/year
- 2011 - 2020 rate of increase : 6%/year (assumed)

Definition of Available Capacity and Guaranteed Capacity

The following two methods are used to calculate available capacity and guaranteed capacity.

- 1) Available capacity ① = Total available installed capacity - (largest unit + second largest unit + largest GTG unit)
- 2) Guaranteed capacity ① = Available capacity ① × 0.95
- 3) Available capacity ② = Total available installed capacity × 0.9
- 4) Guaranteed capacity ② = Available capacity × 0.9
= Total installed capacity × 0.81

Guaranteed Supply Capacity and Peak Power Demand
(Unit: MW)

Year	1995	1996	1997	1998	1999	2000	2001	2002	2003
Available Installed Capacity	2756	2603	2716	5436	5773	5811	5809	5826	5758
Guaranteed Capacity ①	2205	2060	2124	4594	4914	4950	4949	4965	4900
Guaranteed Capacity ②	2232	2108	2200	4403	4676	4707	4705	4719	4664
Peak Demand ③	2725	2970	3238	3529	3847	4193	4486	4800	5136
Balance (③ - ①)	-520	-911	-1113	1065	1068	758	462	164	-236
Balance (③ - ②)	-493	-862	-1038	874	830	514	219	-81	-472

Power Supply and Demand Balance in Syria

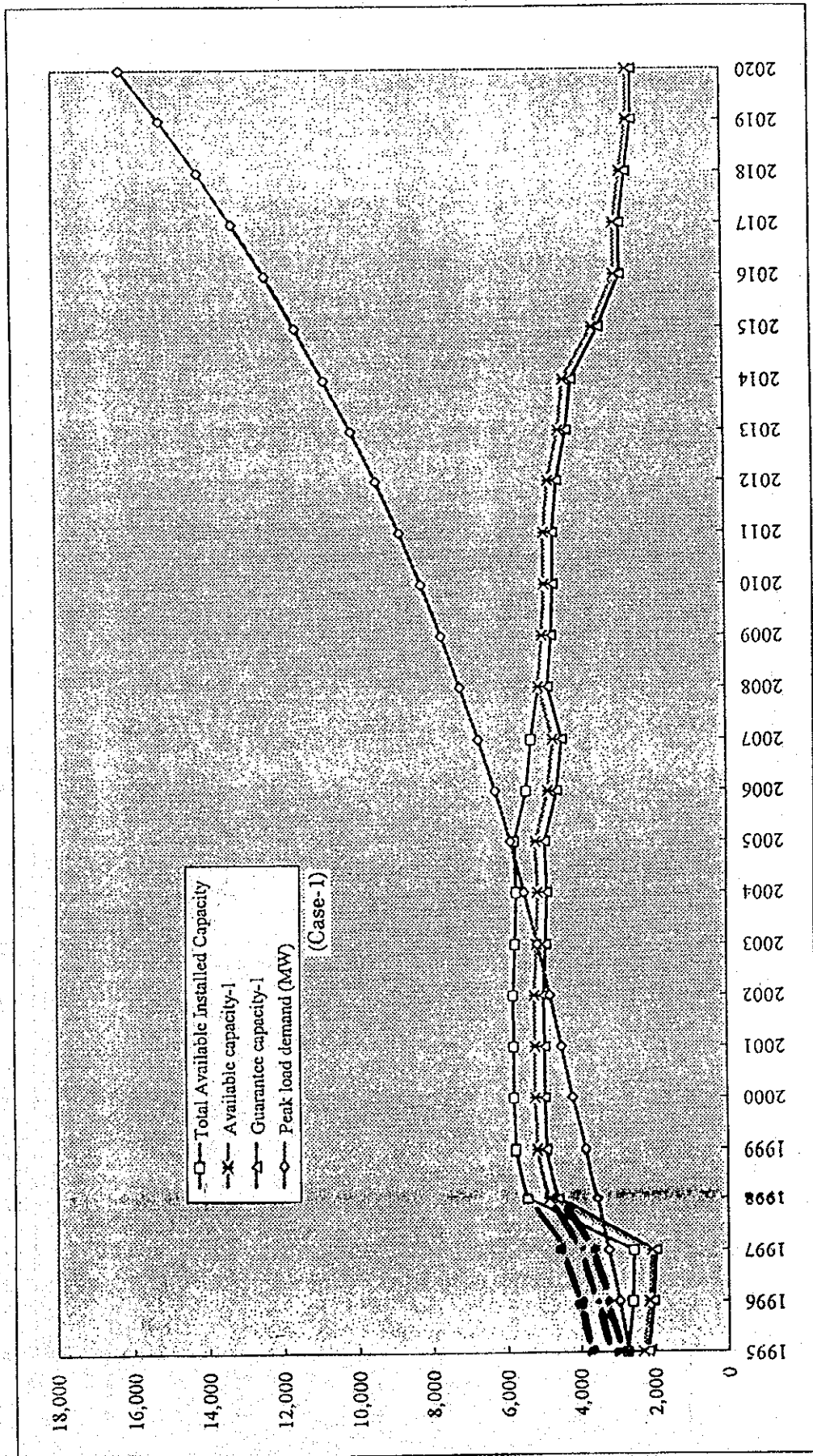

Power Supply and Demand Balance in Syria

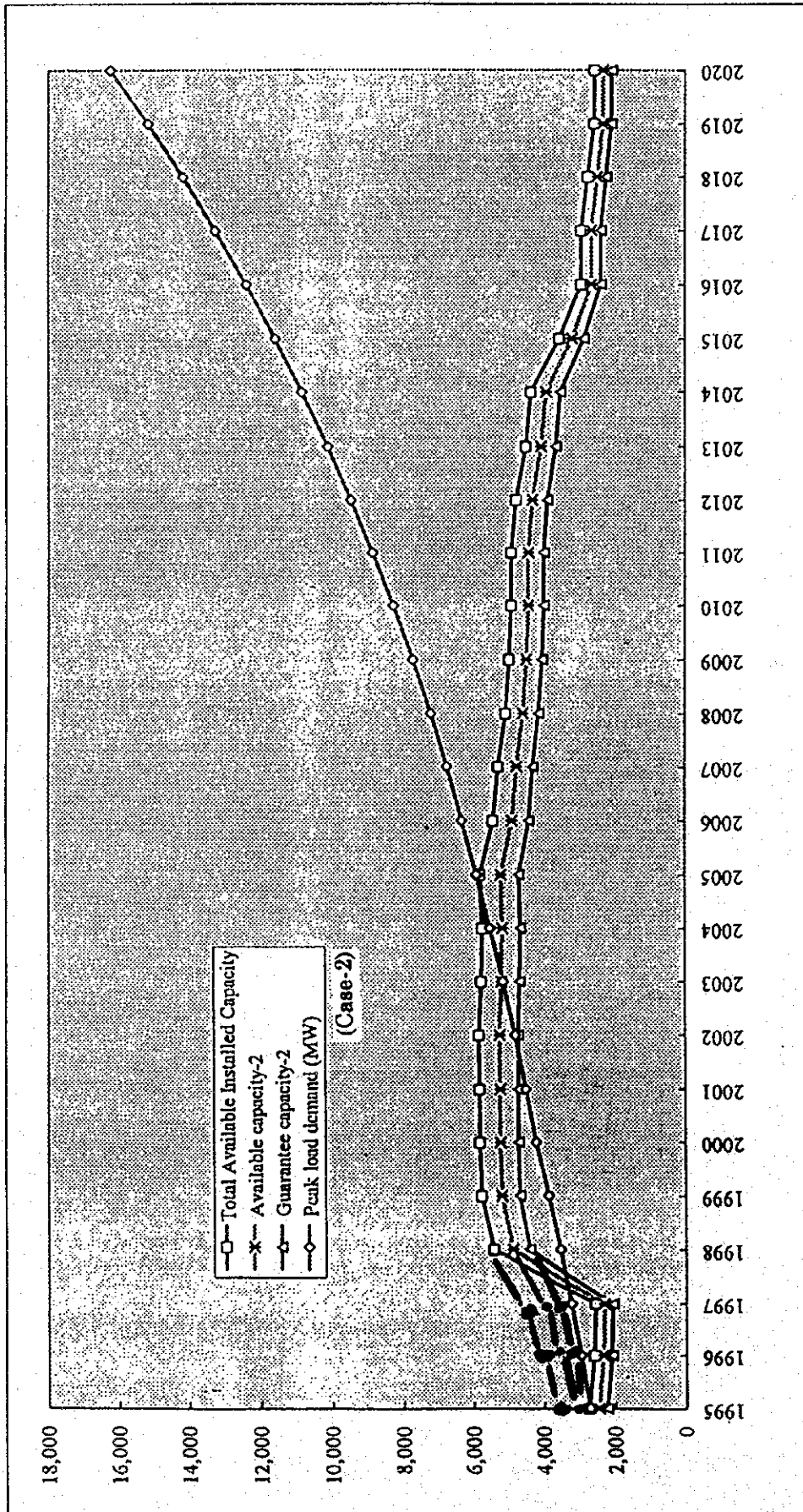

Causes of Unit Declined Output, Declined Efficiency and Measures in HFO fired Unit.

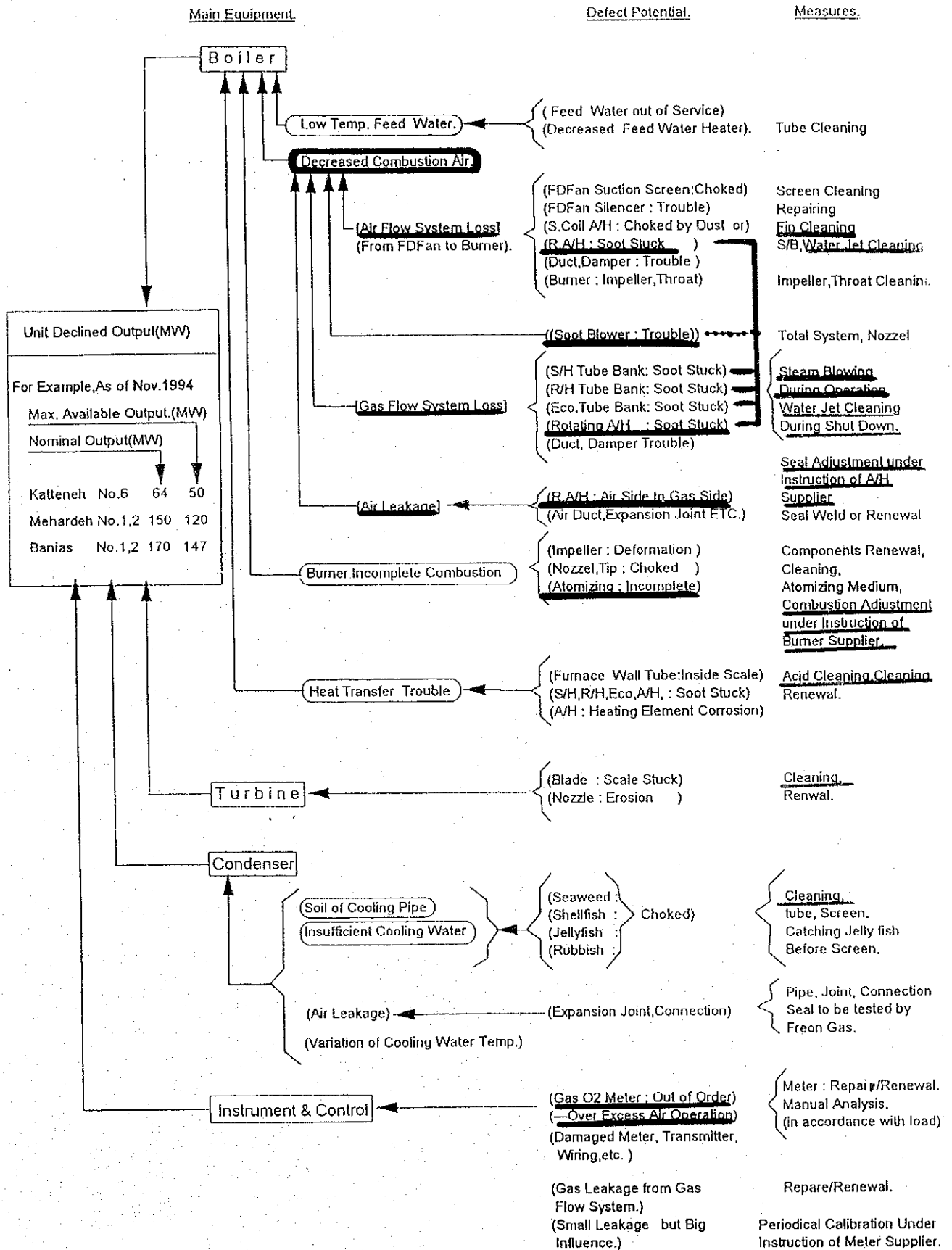

Basic Concept For Boiler Rehabilitation Proposal

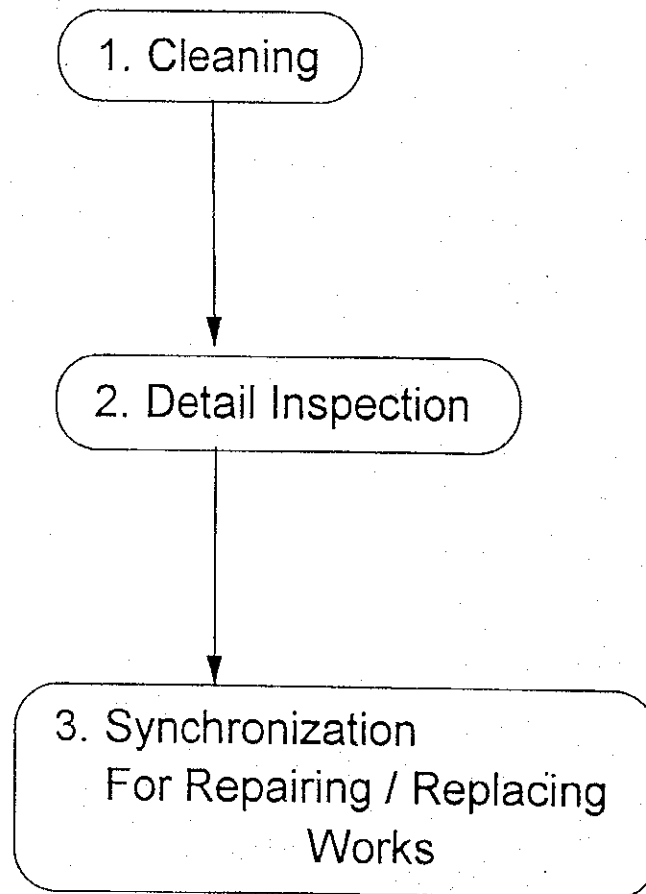

Boilers are Human-Beings

We can find out many similarities between steam generators (Boilers) and human-beings.

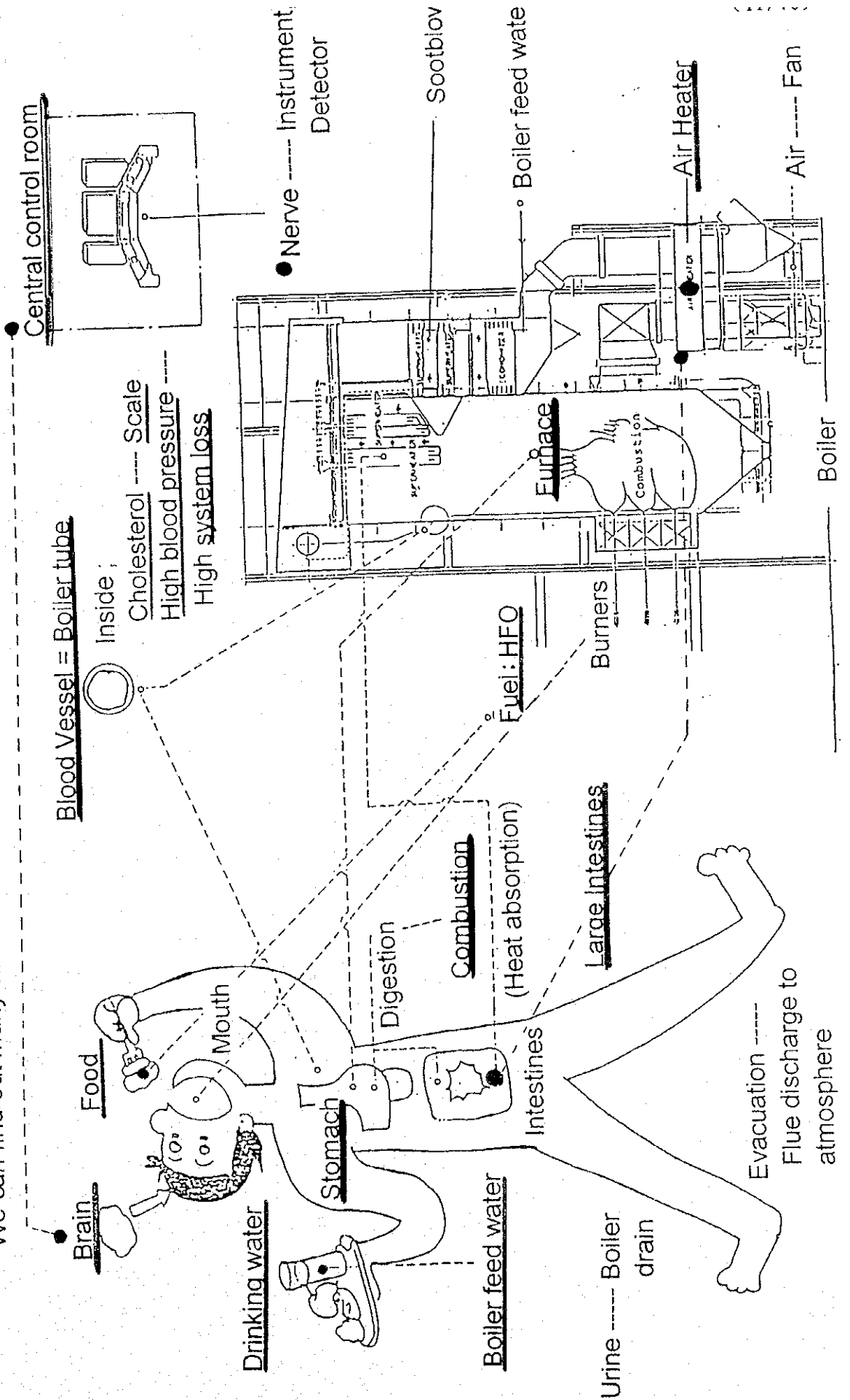

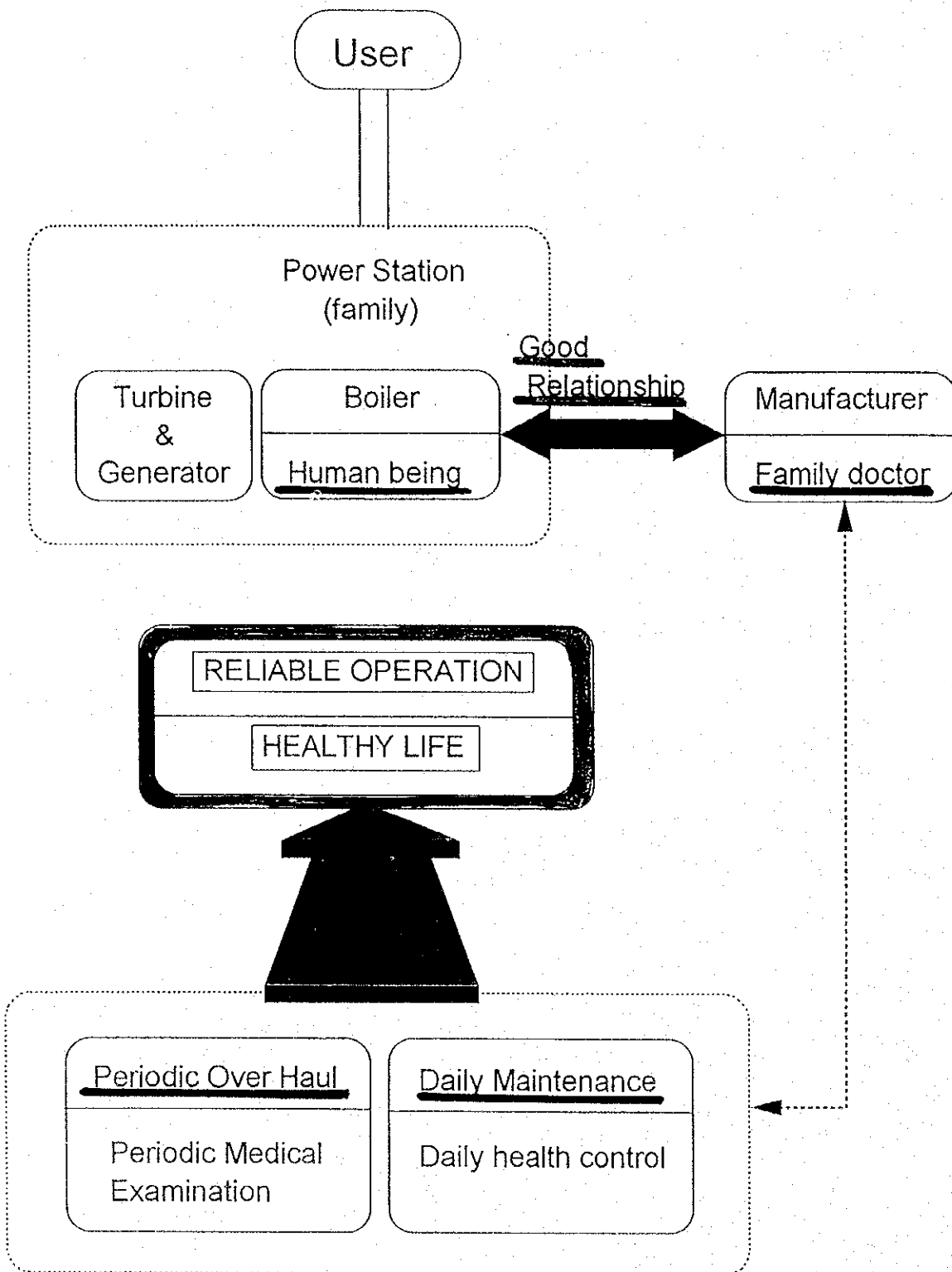

Recommendation on Maintenance

Rehabilitation Master Time Schedule

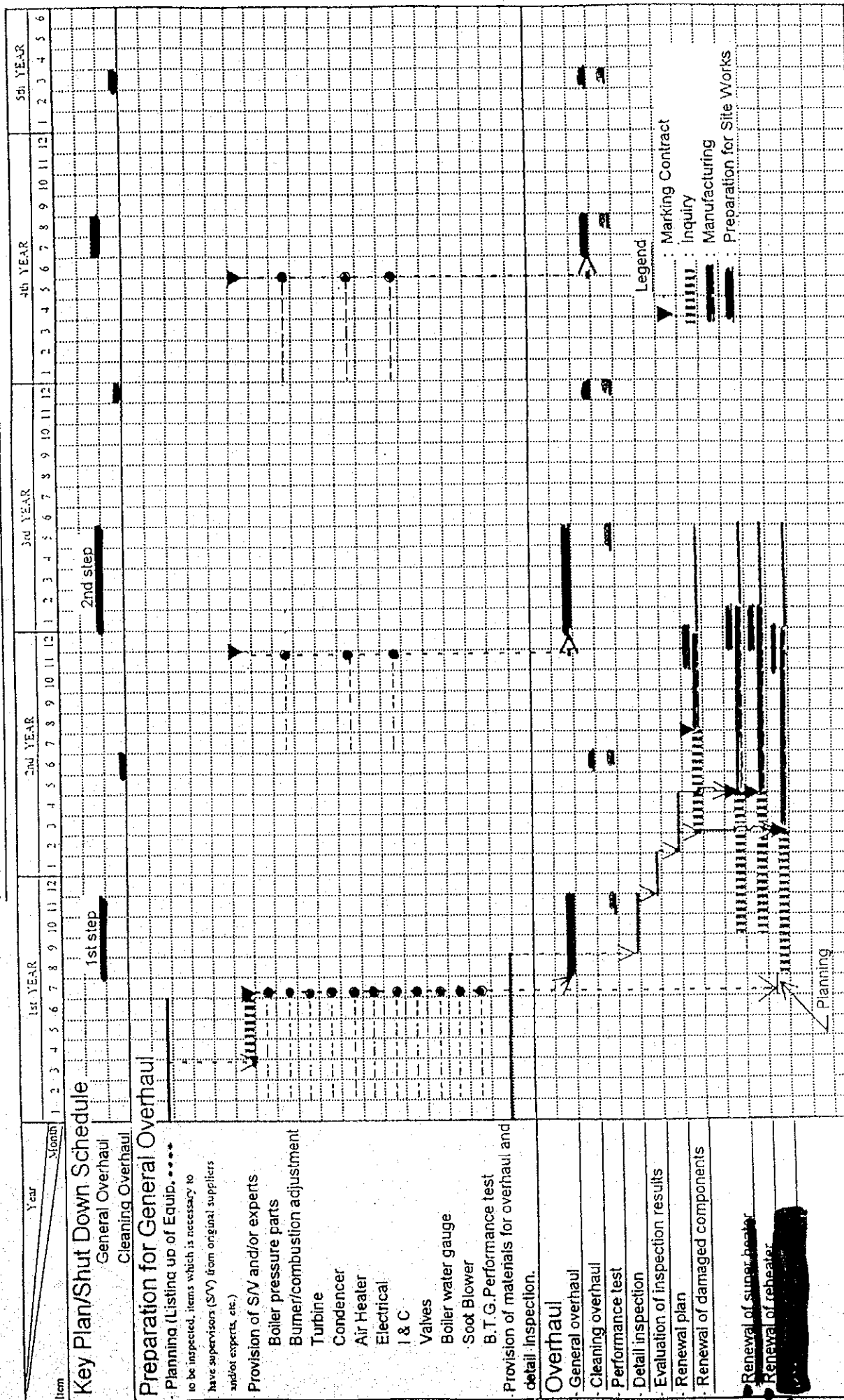
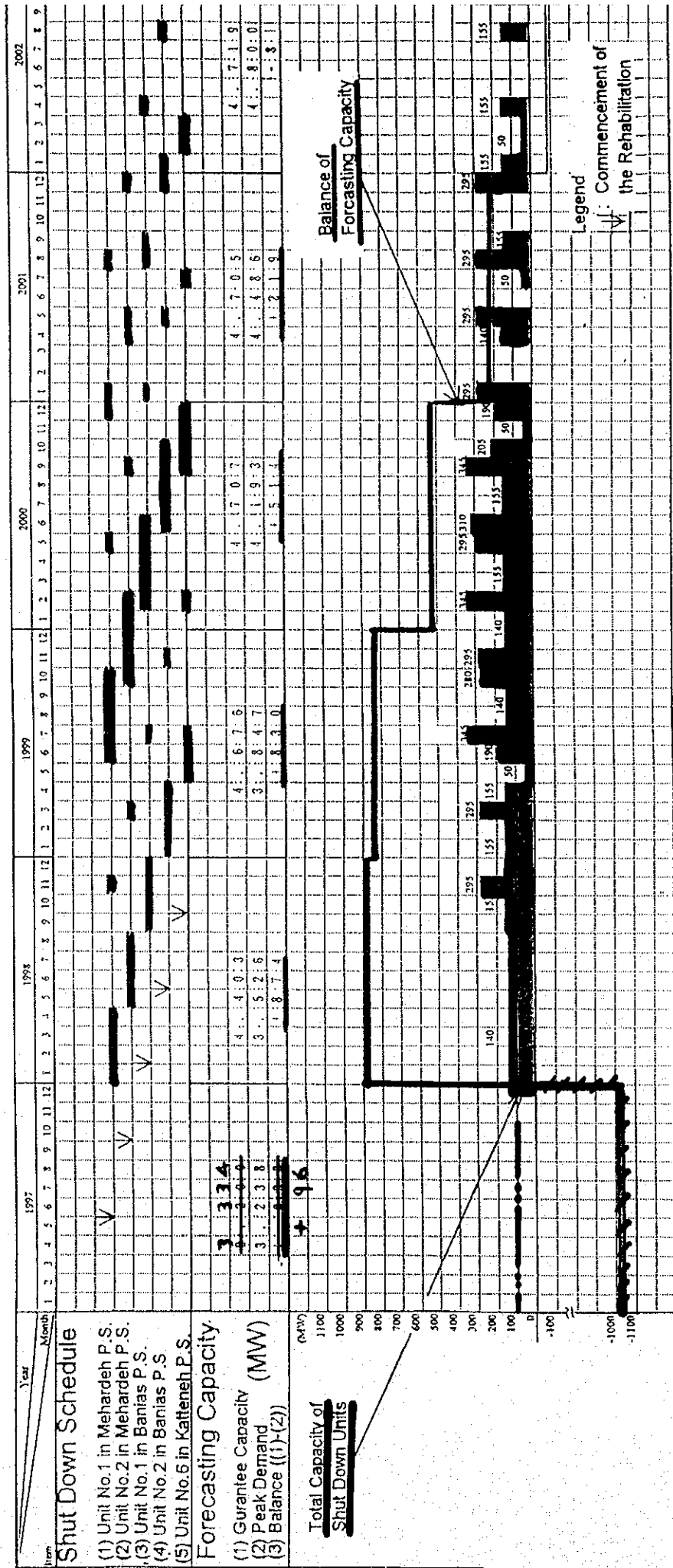

Fig.2.1.9 Rehabilitation Master Schedule



Banias P.S

Inspection Items on Pressure Parts for Banias No. 1&2

Drum

- (1) VI.
- (2) PT Of Weld Parts (Drum Inside) ; Weld Seam, Nozzle and Lugs.
- (3) MT Of Weld Parts (Drum Outside) ; Selected Parts of Longitudinal Seam. Nozzle..

(SH-3) Outlet Header

- (1) MT Of Weld Parts of Tube Stubs.
- (2) MT Of Weld Parts of Drain Nozzle.
- (3) ST Of Outside Surface of Welded Part of Outlet Nozzle.
- (4) VI(Fiber-scope) Of Inside Surface of Outlet Nozzle.

Economizer Tube (Eco.)

- (1) Wall Thickness.(UT)

Super Heater Tube (SH-3), — (7.1),(7.2),(7.3)

- (1) Wall Thickness.(UT)
- (2) MT Of Weld Parts of Lugs.
- (3) Tube Sampling Investigation.

Super Heater Tube (SH-2), — (6.3)Element Front & Rear

- (1) Wall Thickness.(UT)
- (2) MT Of Weld Parts of Lugs.

Main Steam Pipe

- (1) MT Of Weld Parts of Support Lugs.
- (2) VI(Fiber-scope) Of Internal Surface (for drain attack)

Hot Reheat Pipe

- (1) MT Of Weld Parts of Support Lugs.
- (2) VI(Fiber-scope) Of Internal Surface (for drain attack)

(SH-1) Inlet Header

- (1) MT Of Weld Parts of Tube Stubs.
- (2) MT Of Weld Parts of Drain Nozzle.

Reheater Outlet Header

- (1) MT Of Weld Parts of Tube Stubs.
- (2) MT Of Weld Parts of Drain Nozzle.
- (3) ST Of Outside Surface of Welded Part of Outlet Nozzle.

Reheater Tube (8.3), (8.4),(8.5)

- (1) Wall Thickness.(UT)
- (2) MT Of Weld Parts of Lugs.
- (3) Tube Sampling Investigation.

Economizer Tube (Eco.)

- (1) Wall Thickness.(UT)

(2) VI, Tube Outside Surface.(Corrosion)

Economizer Inlet Header

- (1) VI(Fiber-scope) Of Inside Surface of Tube Stubs.

Furnace W/W Tube

- (1) VI & PT Of Weld Parts at Membrane-bars for. Each opening, such as Burner Throats, A D openings and S B openings.

(2) PT Of Welded Connection of Tie-bars for Buckstay.

(3) VI Of Corner Condition of Buckstay.

(4) PT Of Weld Parts of lugs on side wall for Furnace Hopper Support Girders.

(5) Thickness Of every W/W Tube ; Side Walls, Front & Rear Walls.(UT)

(6) Tube Sampling Investigation ; Front and Rear Wall Left & Rear Walls(Burner Level), Slope Ports

(7) All W/W Tube (UT with Transducer)

SH Attenuator

(1) PT Of Spray Nozzle for Fatigue Crack.

(2) VI (Fiber-scope) Of Internal Pipe for Fatigue Crack.

RH Attenuator

(1) PT Of Spray Nozzle for Fatigue Crack.

(2) VI (Fiber-scope) Of Internal Pipe for Fatigue Crack.

Note ; MT:Magnetic particle test. PT:Penetration test. VI:Visual inspection. ST: Sump. test (replica) UT: Ultra sonic test

SB: Soot Blower. AD: Access Door.

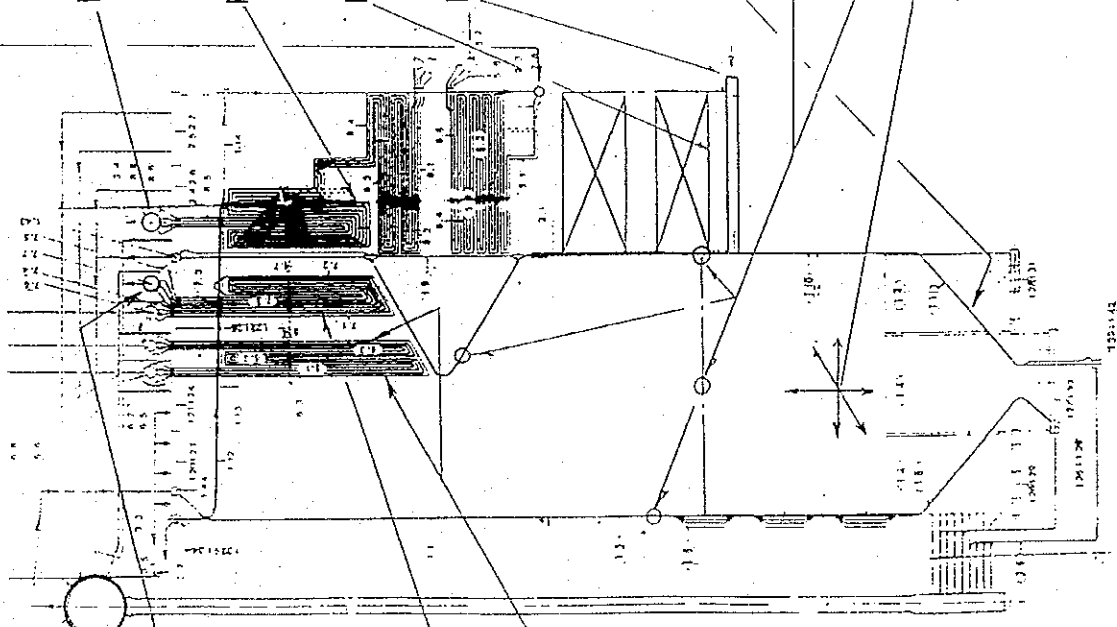

Other Inspection Items

Burner, Atomizer Inspection / Replace Factor

Burner ; } Erosion, Corrosion.
 Atomizer ; }
 Impeller ; High Temp. Oxidation, Corrosion.
 Air Register ; Thermal Deformation Erosion.
 Ignition Torch; Erosion, Deterioration.

Automated ; }
 Facilities ; }
 -Flame Detector ; Deterioration (Sensitivity)
 -Limit Switch ; Deterioration
 -Air Cylinder ; Deterioration
 -Motor Drive ; Deterioration

(Burner Maintenance and Combustion Adjustment under instruction of Burner Supplier every Year to be Carried Out)

Air Heater

- a. Heating Element.
 - (1) Element ; Corrosion / Erosion (VI), Weight
 - (2) Stiffener ; Corrosion / Erosion (VI), Plate Thickness (VI).
- b. Seal Component.
 - (1) Radial Seal, Circumferential Seal, Rotor Seal.
 - (2) Clearance of Seal Materials (VI), Adjustment.
- c. Rotor.
 - (1) Welded Parts of Rotor ; (VI), (PT)
 - (2) Fit up Bolts, Pin Rack ; (VI).

Note ; PT: Penetration test. VI: Visual inspection.

Soot Blower System.

- a. Nozzle, Lance Tube. (VI)
 - (1) Blockade of Blowing Nozzle
 - (2) Boiler Tube Damage due to Soot Blowing
 - (3) Nozzle ; (VI) Erosion, Corrosion, Crack (PT).
 - (4) Lance Tube, Feed Pipe ; Corrosion, Deformation.
 - (5) Gland ; Erosion, Corrosion.
 - (6) Start Point of Steam Blowing
- b. Head Valve
 - (1) Valve Body, Valve Spindle.
 - (2) Valve Seat, Spring.
- c. Wall Box.
- d. Drive System.
 - (1) Gear Box.
 - (2) Gear, Bearing, Chain.
 - (3) Lubricant.

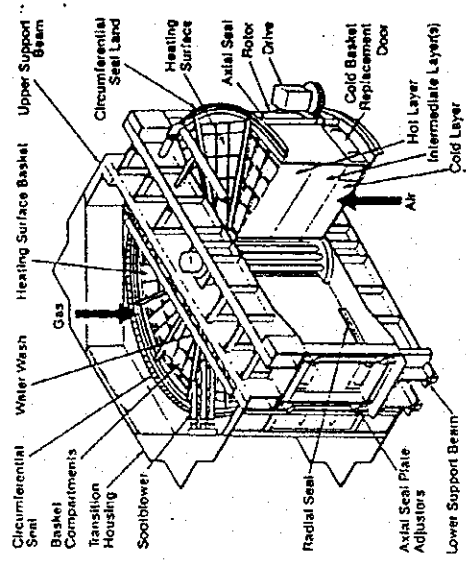
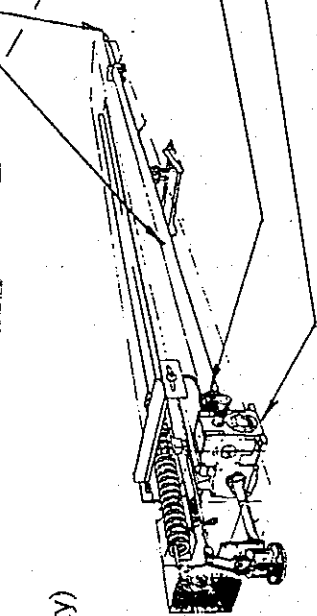
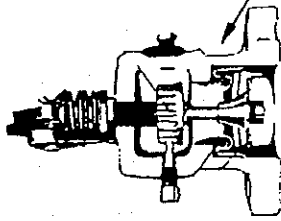

- d. Housing. (VI)
 - (1) Corrosion
 - (2) Deformation
- e. Bearing (VI)
- f. Rotor Balance
- g. Confirmation of Seal Clearance.
 - Confirmation of Air Leakage Percent During Performance Test.
 - (—Under instruction of the Air Heater Supplier)

Inspection Items on Pressure Parts for Mehardeli No. 1&2

Drum

- (1) VI.
- (2) PT Of Weld Parts (Drum Inside) ; Weld Seam, Nozzle and Lugs.
- (3) MT Of Weld Parts (Drum Outside) ; Selected Parts of Longitudinal Seam. Nozzle..

Reheater Outlet Header

- (1) MT Of Weld Parts of Tube Stubs.
- (2) MT Of Weld Parts of Drain Nozzle.
- (3) ST Of Outside Surface of Welded Part of Outlet Nozzle.

Reheater Tube

- (1) Wall Thickness.(UT)
- (2) MT Of Weld Parts of Lugs.
- (3) Tube Sampling Investigation.

(SHT) Outlet Header

- (1) MT Of Weld Parts of Tube Stubs.
- (2) MT Of Weld Parts of Drain Nozzle.
- (3) ST Of Outside Surface of Welded Part of Outlet Nozzle.
- (4) VI(Fiber-scope) Of Inside Surface of Outlet Nozzle.

Super Heater Tube (SHT)

- (1) Wall Thickness.(UT)
- (2) MT Of Weld Parts of Lugs.
- (3) Tube Sampling Investigation.

Super Heater Tube (SMT)

- (1) Wall Thickness.(UT)
- (2) MT Of Weld Parts of Lugs.

Main Steam Pipe

- (1) MT Of Weld Parts of Support Lugs.
- (2) VI(Fiber-scope) Of Internal Surface (for drain attack)

Hot Reheat Pipe

- (1) MT Of Weld Parts of Support Lugs.
- (2) VI(Fiber-scope) Of Internal Surface (for drain attack)

Economizer Tube (Eco.)

- (1) Wall Thickness.(UT)
- (2) VI, Tube Outside Surface.(Corrosion)

Economizer Inlet Header

- (1) VI(Fiber-scope) Of Inside Surface of Tube Stubs.

Furnace W/W Tube

- (1) VI & PT Of Weld Parts at Membrane-bars for. Each opening, such as Burner Throats, AD openings and SB openings.
- (2) PT Of Welded Connection of Tie-bars for Buckstay.

(3) VI Of Corner Condition of Buckstay.

(4) PT Of Weld Parts of lugs on side wall for Furnace Hopper Support Girders.

(5) Thickness Of every W/W Tube ; Side Walls, Front & Rear Walls.(UT)

(6) Tube Sampling Investigation ; Front and Rear Wall Left & Rear Walls(Burner Level), Slope Ports

SH Attemperator

- (1) PT Of Spray Nozzle for Fatigue Crack.

- (2) VI (Fiber-scope) Of Internal Pipe for Fatigue Crack.

RH Attemperator

- (1) PT Of Spray Nozzle for Fatigue Crack.

- (2) VI (Fiber-scope) Of Internal Pipe for Fatigue Crack.

Note ; MT:Magnetic particle test. PT:Penetration test. VI:Visual inspection. ST:Sump. test (replica) UT:Ultra sonic test.

SB: Soot Blower. AD:Access Door.

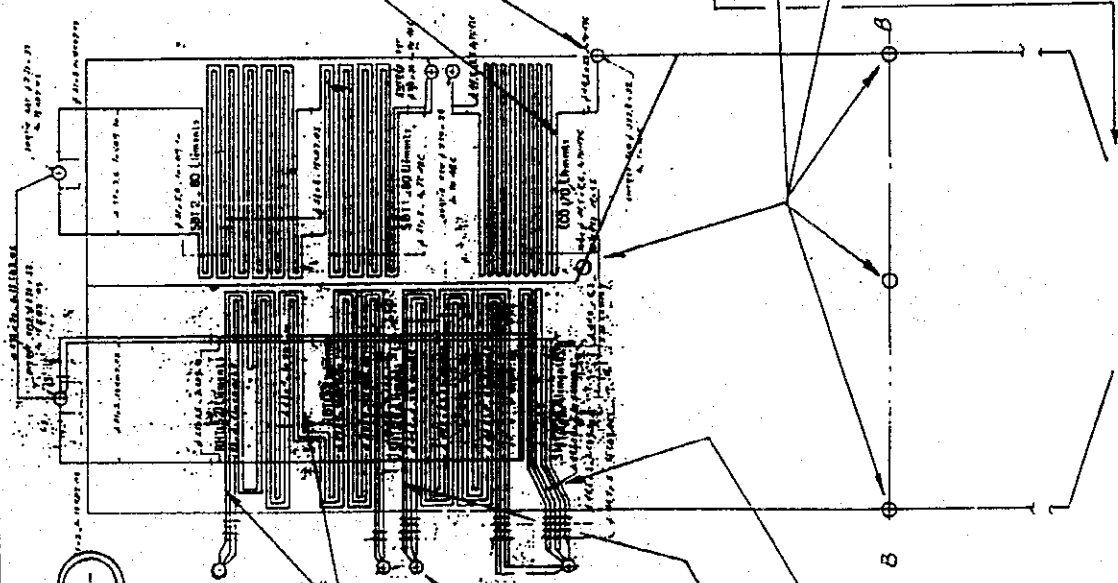

Other Inspection Items

Burner, Atomizer Inspection / Replace

- Factor
 - Oil Gun ; Erosion, Corrosion.
 - Air Nozzle ; High Temp. Oxidation, Corrosion.
- Air Nozzle ; Thermal Deformation Erosion.
- Ignition Torch; Erosion, Deterioration.
- Automated ;
- Facilities ;
- Flame Detector ; Deterioration(Sensitivity)
- Limit Switch ; Deterioration
- Air Cylinder ; Deterioration

(Burner Maintenance and Combustion Adjustment under Instruction of Burner Supplier every Year to be Carried Out)

Air Heater

- a. Heating Element.
 - (1) Element ; Corrosion / Erosion(VI), Weight.
 - (2) Stiffener ; Corrosion / Erosion(VI), Plate Thickness(VI).
- b. Seal Component.
 - (Radial Seal, Circumferential Seal, Rotor Seal.
 - (1) Corrosion / Erosion(VI)
 - (2) Clearance of Seal Materials(VI), Adjustment.
- c. Rotor.
 - (1) Welded Parts of Rotor ; (VI), (PT)
 - (2) Fit up Bolts, Pin Rack ; (VI).

Soot Blower System.

- a. Nozzle, Lance Tube. (VI)
 - (1) Blockade of Blowing Nozzle
 - (2) Boiler Tube Damage due to Soot Blowing
 - (3) Nozzle ; (VI) Erosion, Corrosion, Crack(PT).
 - (4) Lance Tube, Feed Pipe ; Corrosion, Deformation.
 - (5) Gland ; Erosion, Corrosion.
 - (6) Start Point of Steam Blowing
- b. Head Valve
 - (1) Valve Body, Valve Spindle.
 - (2) Valve Seat, Spring.
- c. Wall Box.
- d. Drive System.
 - (1) Gear Box.
 - (2) Gear, Bearing, Chain.
 - (3) Lubricant.

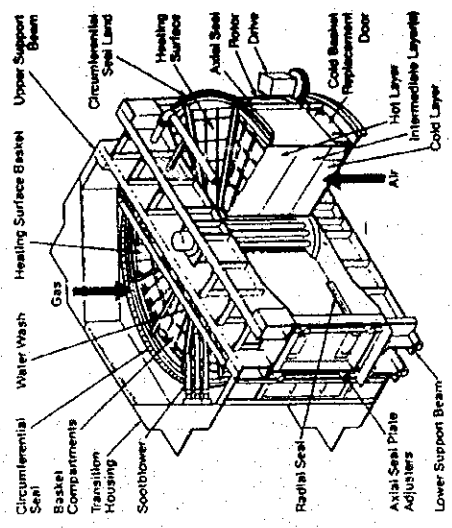
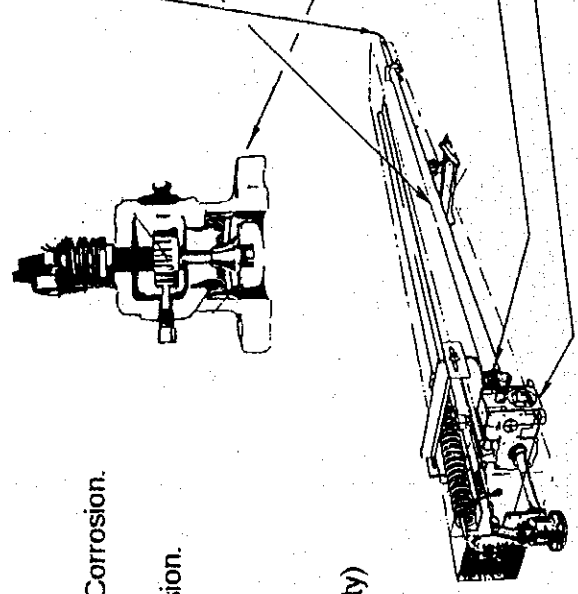

- d. Housing. (VI)
 - (1) Corrosion
 - (2) Deformation
- e. Bearing (VI)
- f. Rotor Balance
 - g. Confirmation of Seal, Clearance.
 - Confirmation of Air Leakage Percent During Performance Test.
 - (—Under Instruction of the Air Heater Supplier)

Note ; PT: Penetration test. VI: Visual inspection.

Inspection Items on Pressure Parts for Katteneh No.6

Katteneh, P. S

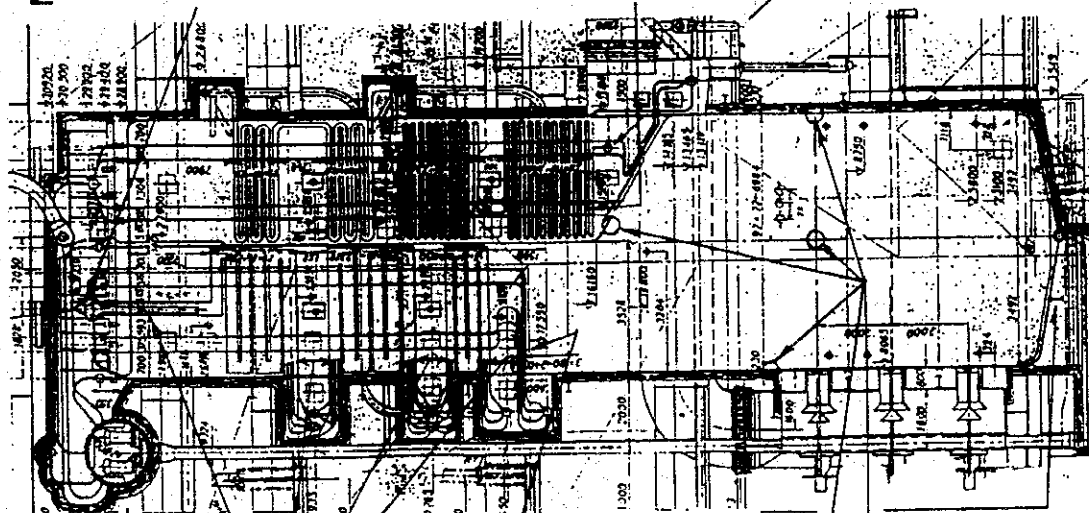

Drum

- (1) VI.
- (2) PT Of Weld Parts (Drum Inside) ; Weld Seam, Nozzle and Lugs.
- (3) MT Of Weld Parts (Drum Outside) ; Selected Parts of Longitudinal Seam Nozzle.

Super Heater Tube

- (1) Wall Thickness.(UT)
- (2) MT Of Weld Parts of Lugs.

Furnace W/W Tube

- (1) VI & PT Of Weld Parts at Membrane-bars for. Each opening, such as Burner Throats, AD openings and SB openings.
- (2) PT Of Welded Connection of Tie-bars for Buckstay.
- (3) VI Of Corner Condition of Buckstay.
- (4) PT Of Weld Parts of lugs on side wall for Furnace Hopper Support Girders.
- (5) Thickness Of every W/W Tube ; Side Walls, Front & Rear Walls.(UT)
- (6) Tube Sampling Investigation ; Front and Rear Wall Left & Rear Walls(Burner Level), Slope Ports

Main Steam Pipe

- (1) MT Of Weld Parts of Support Lugs.
- (2) VI(Fiber-scope) Of Internal Surface (for drain attack)

S/H Outlet Header

- (1) MT Of Weld Parts of Tube Stubs.
- (2) MT Of Weld Parts of Drain Nozzle.
- (3) ST Of Outside Surface of Welded Part of Outlet Nozzle.
- (4) VI(Fiber-scope) Of Inside Surface of Outlet Nozzle.

Super Heater Tube

- (1) Wall Thickness.(UT)
- (2) MT Of Weld Parts of Lugs.
- (3) Tube Sampling Investigation.

Economizer Tube (Eco.)

- (1) Wall Thickness.(UT)
- (2) VI,Tube Outside Surface.(Corrosion)

Economizer Inlet Header

- (1) VI(Fiber-scope) Of Inside Surface of Tube Stubs.

SH Attenuator

- (1) PT Of Spray Nozzle for Fatigue Crack.
- (2) VI (Fiber-scope) Of Internal Pipe for Fatigue Crack.

Note ; MT:Magnetic particle test. PT:Penetration test. VI:Visual inspection. ST:Sump. test (replica) UT:Ultra sonic test.

CD: Cost Drawn AM:Access Draw

Katteneh P. S

Other Inspection Items

Burner, Atomizer Inspection / Replace Factor

- Burner ; Erosion, Corrosion.
- Atomizer ; High Temp. Oxidation, Corrosion.
- Impeller ; Thermal Deformation Erosion.
- Air Register ; Erosion, Deterioration.
- Ignition Torch; Erosion, Deterioration.
- Automated ;
- Facilities ;

- Flame Detector ; Deterioration(Sensitivity)
- Limit Switch ; Deterioration
- Air Cylinder ; Deterioration
- Motor Drive ; Deterioration

(Burner Maintenance and Combustion Adjustment under Instruction of Burner Supplier every Year to be Carried Out)

Air Heater

- a. Heating Element.
 - (1) Element ; Corrosion / Erosion(VI), Weight
 - (2) Stiffener ; Corrosion / Erosion(VI), Plate Thickness(VI).
- b. Seal Component.
 - (Radial Seal, Circumferential Seal, Rotor Seal.
 - (1) Corrosion / Erosion(VI)
 - (2) Clearance of Seal Materials(VI). Adjustment.
- c. Rotor.
 - (1) Welded Parts of Rotor ; (VI), (PT)
 - (2) Fit up Bolts, Pin Rack ; (VI).

Soot Blower System.

- a. Nozzle, Lance Tube. (VI)
 - (1) Blockade of Blowing Nozzle
 - (2) Boiler Tube Damage due to Soot Blowing
 - (3) Nozzle ; (VI) Erosion, Corrosion, Crack(PT).
 - (4) Lance Tube, Feed Pipe ; Corrosion, Deformation.
 - (5) Gland ; Erosion, Corrosion.
 - (6) Start Point of Steam Blowing

- b. Head Valve
 - (1) Valve Body, Valve Spindle.
 - (2) Valve Seat, Spring.

- c. Wall Box.

- d. Drive System.
 - (1) Gear Box.
 - (2) Gear, Bearing, Chain.
 - (3) Lubricant.

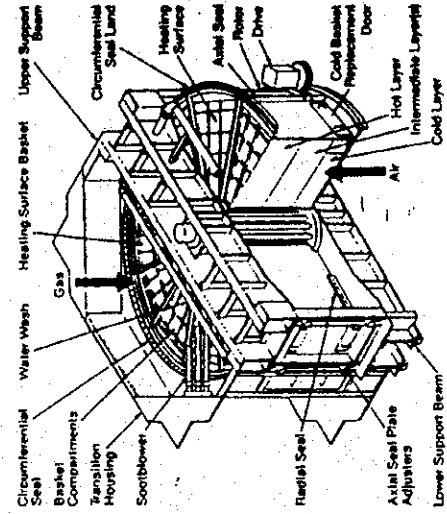
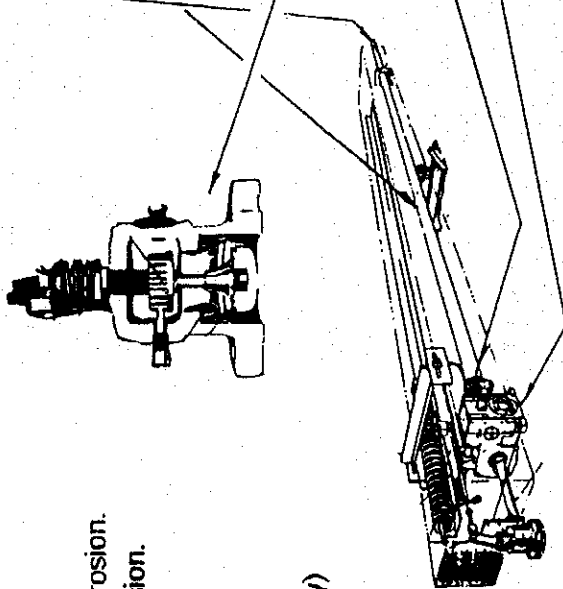

- d. Housing. (VI)
 - (1) Corrosion
 - (2) Deformation
- e. Bearing (VI)
- f. Rotor Balance
- g. Confirmation of Seal Clearance.
 - Confirmation of Air Leakage Percent During Performance Test.
 - (—) Under Instruction of the Air Heater Supplier

Note ; PT: Penetration test. VI: Visual inspection.

Liquid Penetrant

Advantages ;

1. Relatively inexpensive, reasonably rapid, portable.
2. Procecc is simple and easy to learn.
3. Reasonably smooth surfaces are easily interpreted.
4. Accurate for finding surface cracks.

Notes ;

1. Must clean surface of paint, coatings, scale, etc.
2. Only find defects open to surface.
3. Porous and rough surfaces difficult to inspect.
4. May be corrosive to material tested.

Magnetic Particle

Advantages ;

1. Relatively economical and expedient.
2. Portable.
3. Can detect some discontinuities slightly below the surface.
4. Generally fast and continuous.

Notes ;

1. Limited to ferromagnetic materials.
2. Surface preparation required.
3. Some applications require demagnetization.
4. Requires electrical energy.

Ultrasonic

Advantages ;

1. Good penetrating power in fine grain material.
2. High sensitivity permits detection of very small discontinuities.
3. Good accuracy in determining position of internal discontinuities.
Estimating size, shape, nature a characterizing also possible.
4. Only one surface need be accessible.
5. Can find surface and subsurface discontinuities.
6. Portable
7. Operation is electronic, provides almost instantaneous indications of discontinuities.
8. With some systems a permanent record of inspection results is possible.

Notes ;

1. Parts that are rough, irregular in shape, very small or thin or inhomogeneous are difficult to inspect.
2. Extensive technical knowledge is required for the development of inspection procedure.
3. Experienced personnel required.
4. Couplants are required.
5. Reference standards are needed for calibrating equipment.

Replication

Advantages ;

1. Obtains image of component surface.
2. Permits laboratory examination and evaluation of failure mechanisms(creep).
3. Non-destructive test.

Notes ;

1. Can be time consuming and expensive.
2. Production effected by high heat humidity and dust and dirt.

Example of Tube Life Evaluation (Practical and Simple)

For R/H, S/H, Eco, Tube (in case of tube out side corrosion)

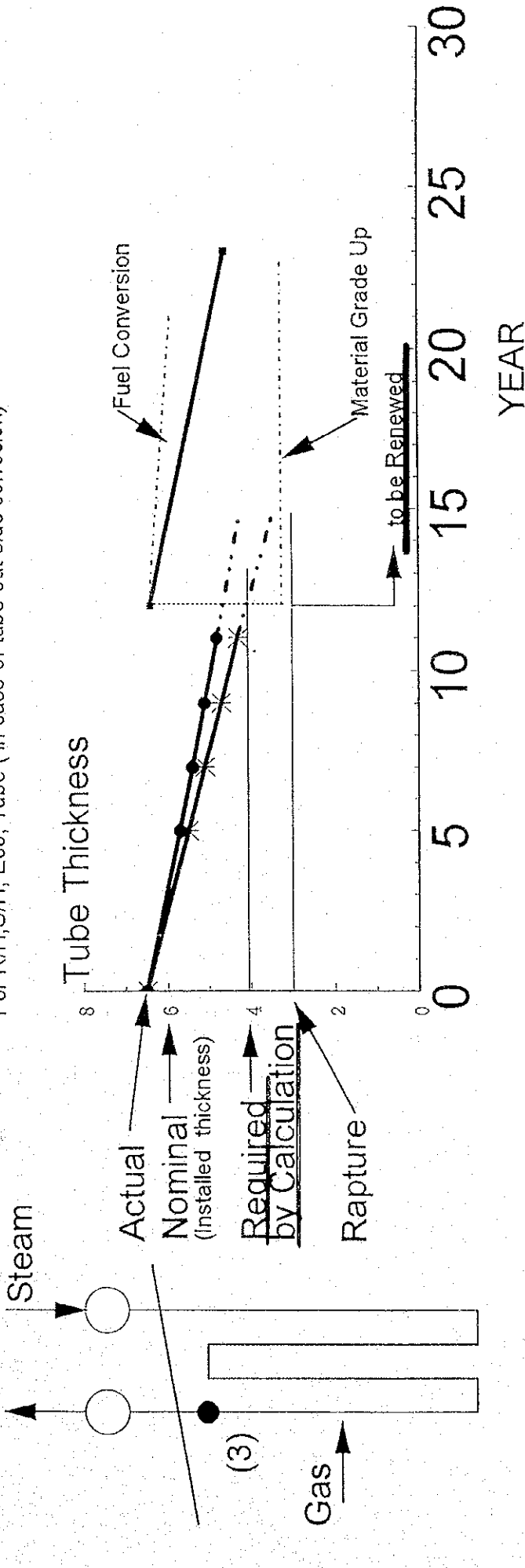

Note. (1) Tube Thickness Tolerance : For Example

ASME Code Tube (ASTM) -0 +24, B S.(+,-) 12%

(2) Required Thickness $t = \frac{pd}{200S+p} + 0.005d + f$ ----- (ASME, JIS)

S=Maximum Allowable Stress of Material (kg/mm²) at Design Metal temperature
 P=Maximum Allowable Working Pressure (kg/cm²)
 d=Outside Diameter of Tube (mm)
 f =Factor

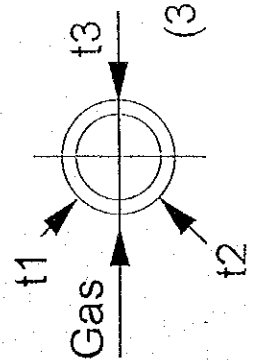

(3) Measuring Point of Tube Thickness ; to be Measured at Same Point Every Time.

Sample Tube Analysis

Sample Tube : from	Furnace	Superheater & Reheater
Length of Sample Tube	1m	1m
Out side Dia Meter	X	X
Tube Thickness	X	X
Tensile Strength	X	(X)
(Creep Test)		(X)
Chemical composition	(X)	(X)
Microscopic Test		X
Sump Test (replica) *1		X(Tube & Header)
Scale Analysis	X	
Scale Thickness	X	(0.15 to 0.25mm) —————> *3
Scale Weight (mg/cm2)	X	(45 to 75mg/cm2) —————> *3
Chemical Analysis	X	

*1. Non Destructive Method.

*2. () As Required.

*3. Volume (mg/cm2) and Thickness (mm) of Attached Scales Requiring Chemical Cleaning.

Non Destructive Method for Residual Life Diagnosis

This method use replicas of metallograph taken from the aged materials.

Diagnosis method		Creep	Fatigue
Metallograph (replica)	Cavity	◎	
	Micro-deformation of grain	◎	
	Micro crack		◎

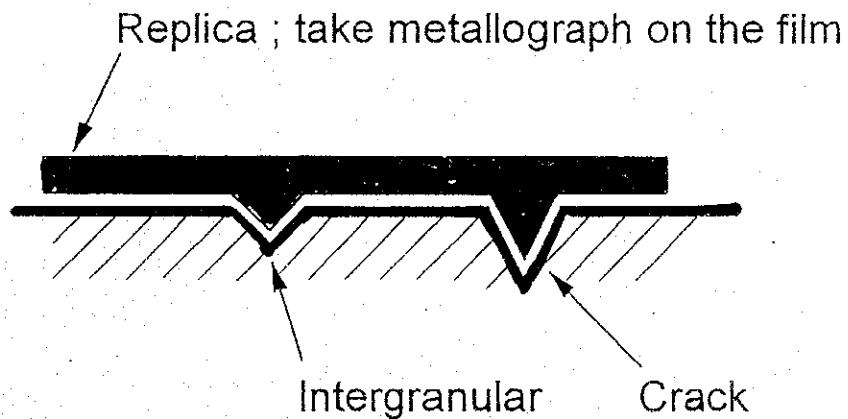

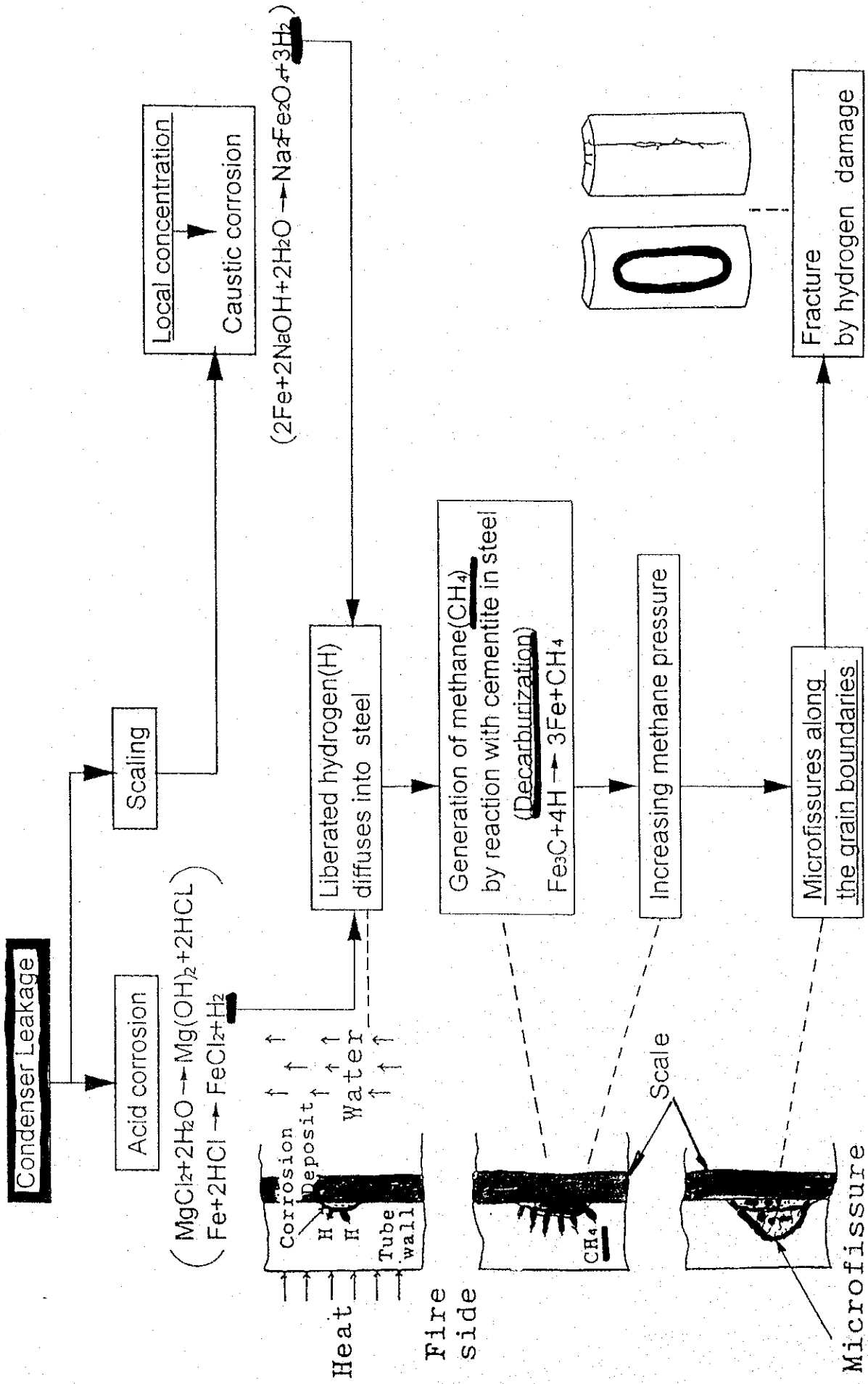

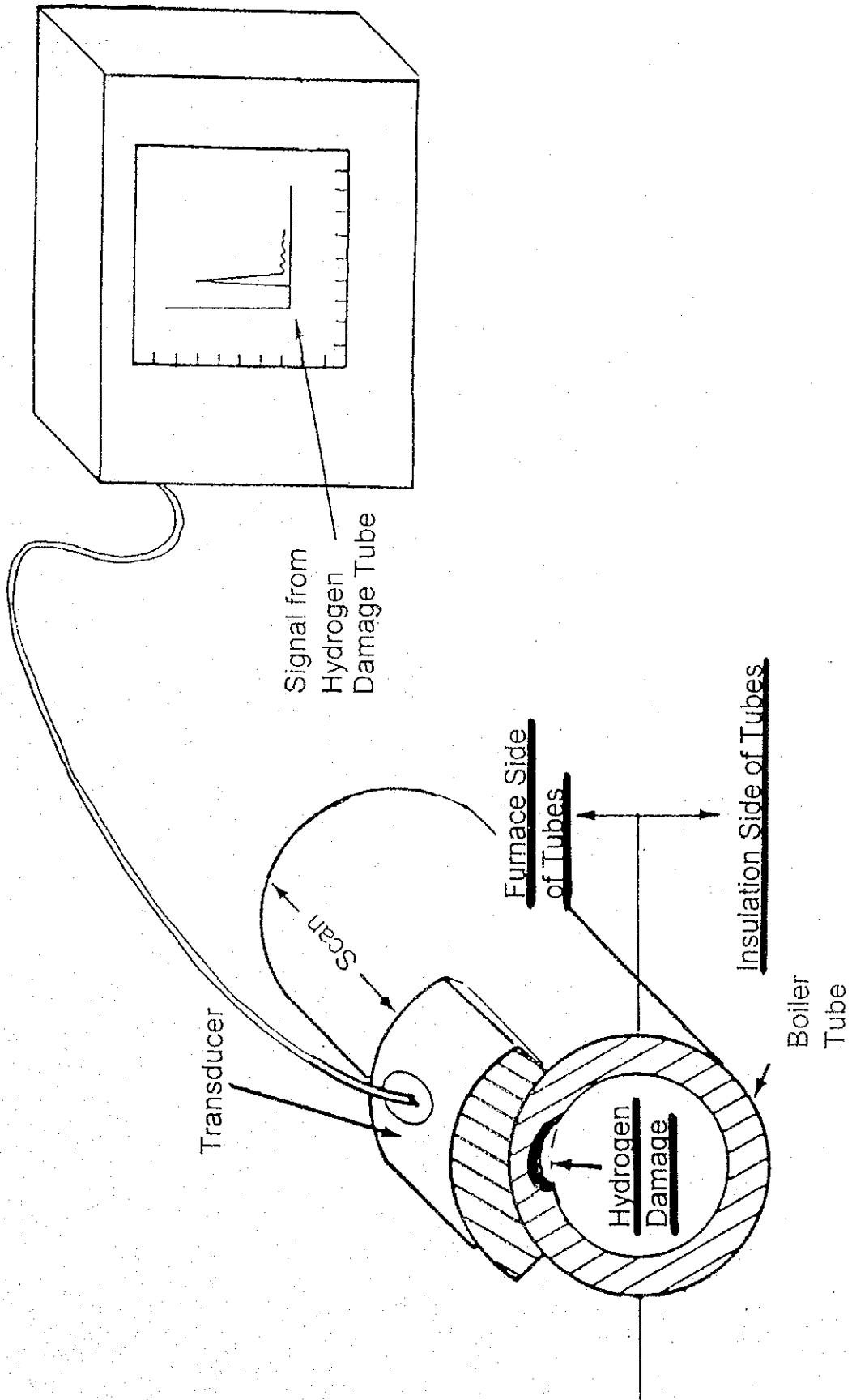

Ultrasonic Method to Detect Hydrogen Damage

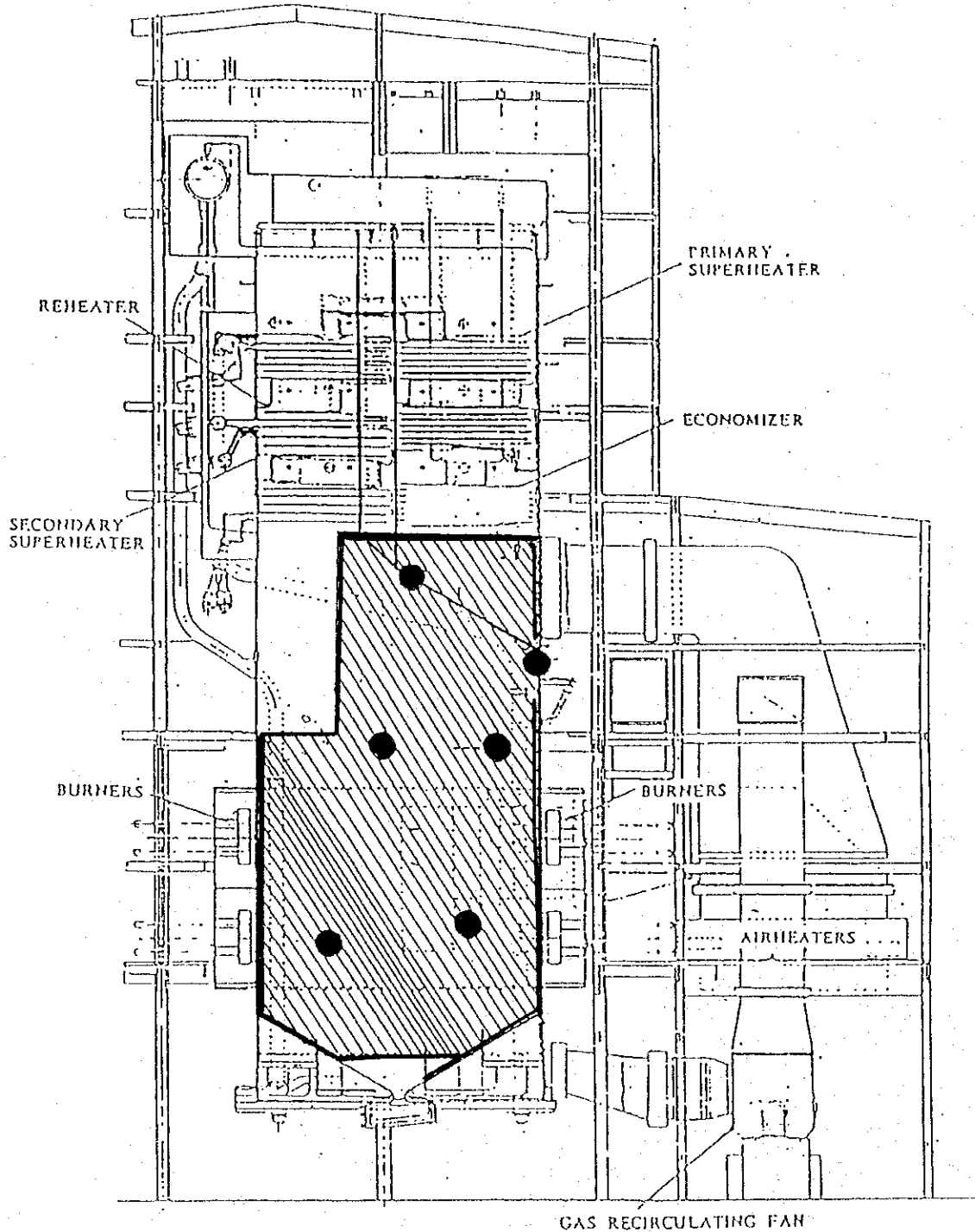

Max. continuous rating	1,207 t/hr (2,661,400 lb/hr)
Superheater outlet pressure	175 kg/sq.cm (2,489 lb/sq.in)
Final steam temperature	541°C (1,005°F)
Reheat steam temperature	541°C (1,005°F)
Feed water temperature	276°C (529°F)
Fuel	Oil



: Replaced Area



: Tube Failure Portion

Damaged Portion due to Hydrogen Attack
and Replaced Area in Furnace Wall.

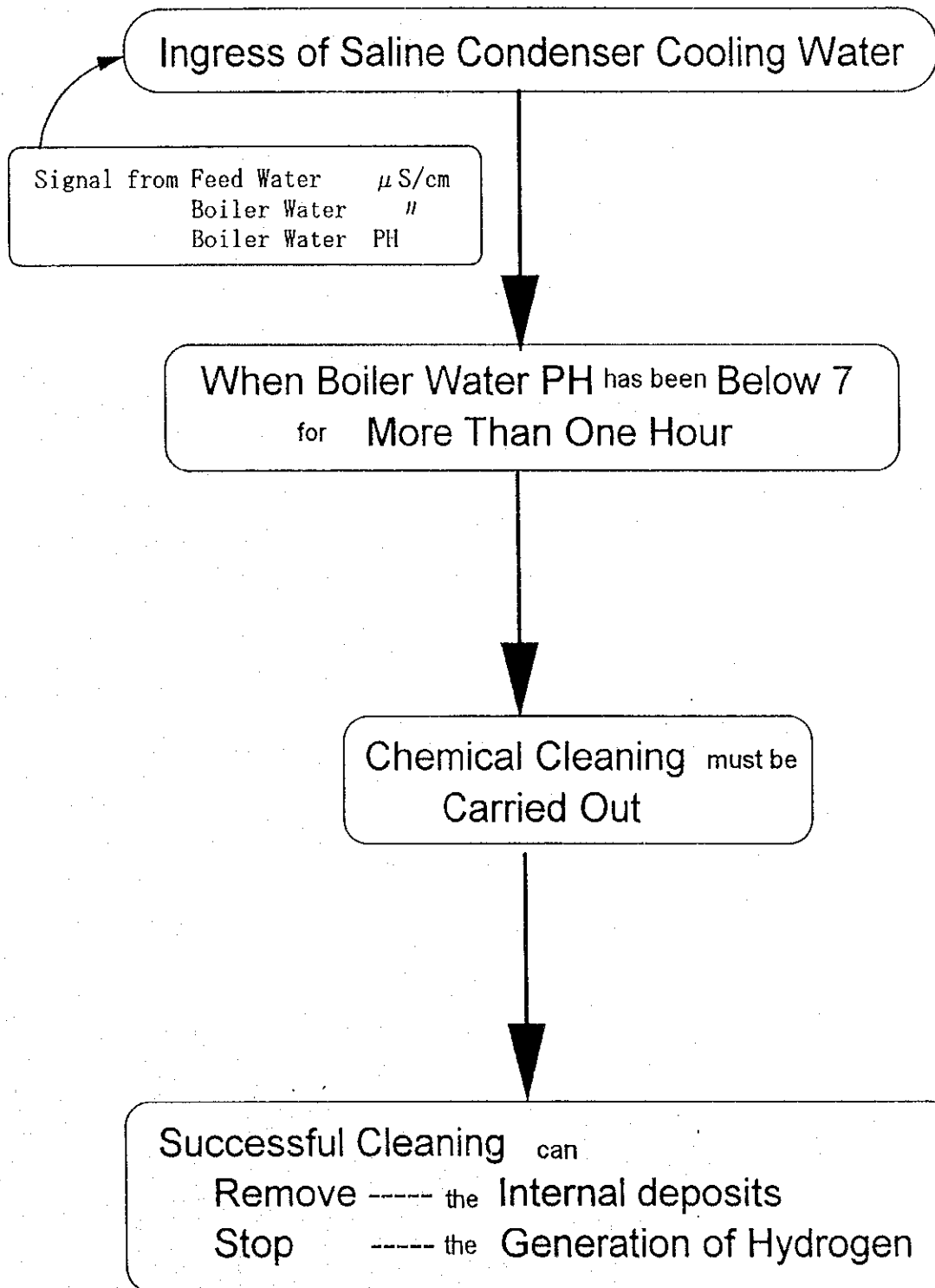

Chemical Cleaning \longleftrightarrow Condenser tube failure

Fuel - Oil Ash Troubles

Super Heater / Reheater
 - Fouling
 - High - Temperature Ash Corrosion

Additives are Effective in Changing Character of Ash Melting Point.

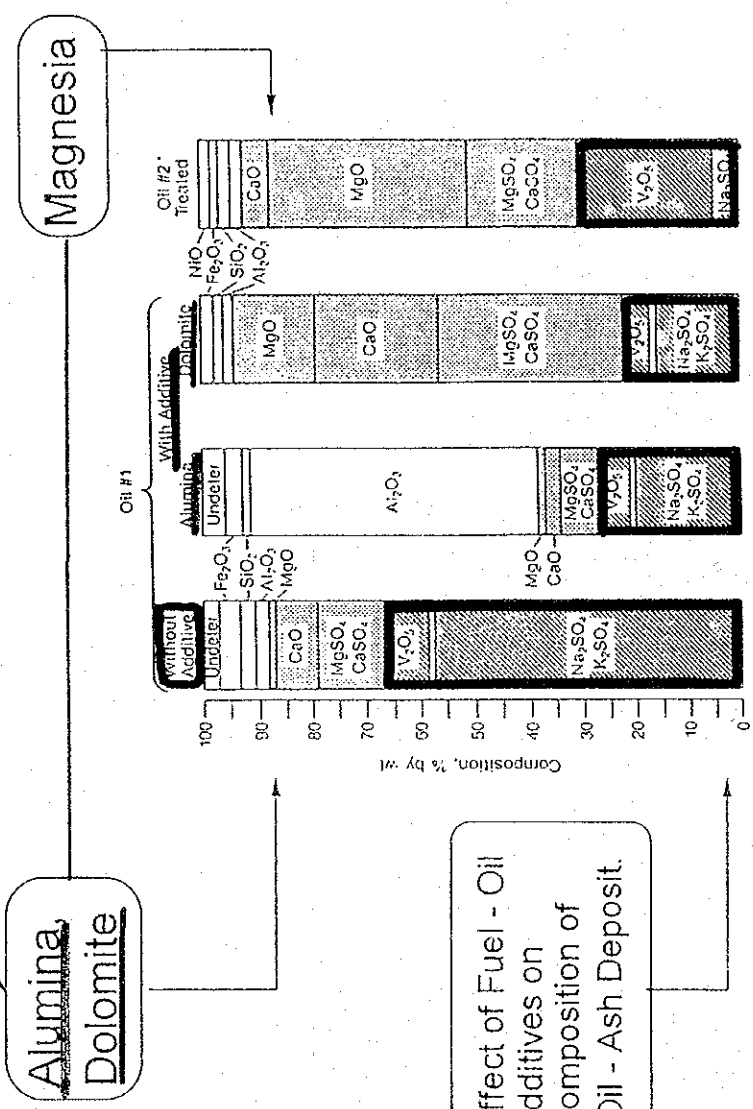

Alumina, Dolomite

Magnesia

	Aluminum Oxide, Al ₂ O ₃	Calcium Oxide, CaO	Magnesium Oxide, MgO	Sodium Sulfate, Na ₂ SO ₄	Vanadium Pentoxide, V ₂ O ₅	Sodium Metavanadate, Na ₂ O · V ₂ O ₅ (=NaVO ₃)
Melting Points(°C)	2050	2570	2500-2800	885	690	630

Residual Fuel Oil

Sodium ; Na Sulfate ; S Vanadium ; V

During Combustion,
 $Na_2SO_4 + V_2O_5 \rightarrow 2NaVO_3 + SO_3$
 885°C 690°C 630°C

Effect of Fuel - Oil Additives on Composition of Oil - Ash Deposit.

☒ Troublesome Constituents ✖

The Reduction of Fouling and High-Temp. Corrosion is Accomplished Basically by Producing a High Melting - Point Ash Deposit.

✖ FROM "STEAM" 40TH EDITION. BACK & WILCOX a Mac Dermott company

general

Proposed Rehabilitation Work

..... For Banias P.S. No.1&2
Mehardeh P.S. No.1&2
Katteneh P.S. No.6

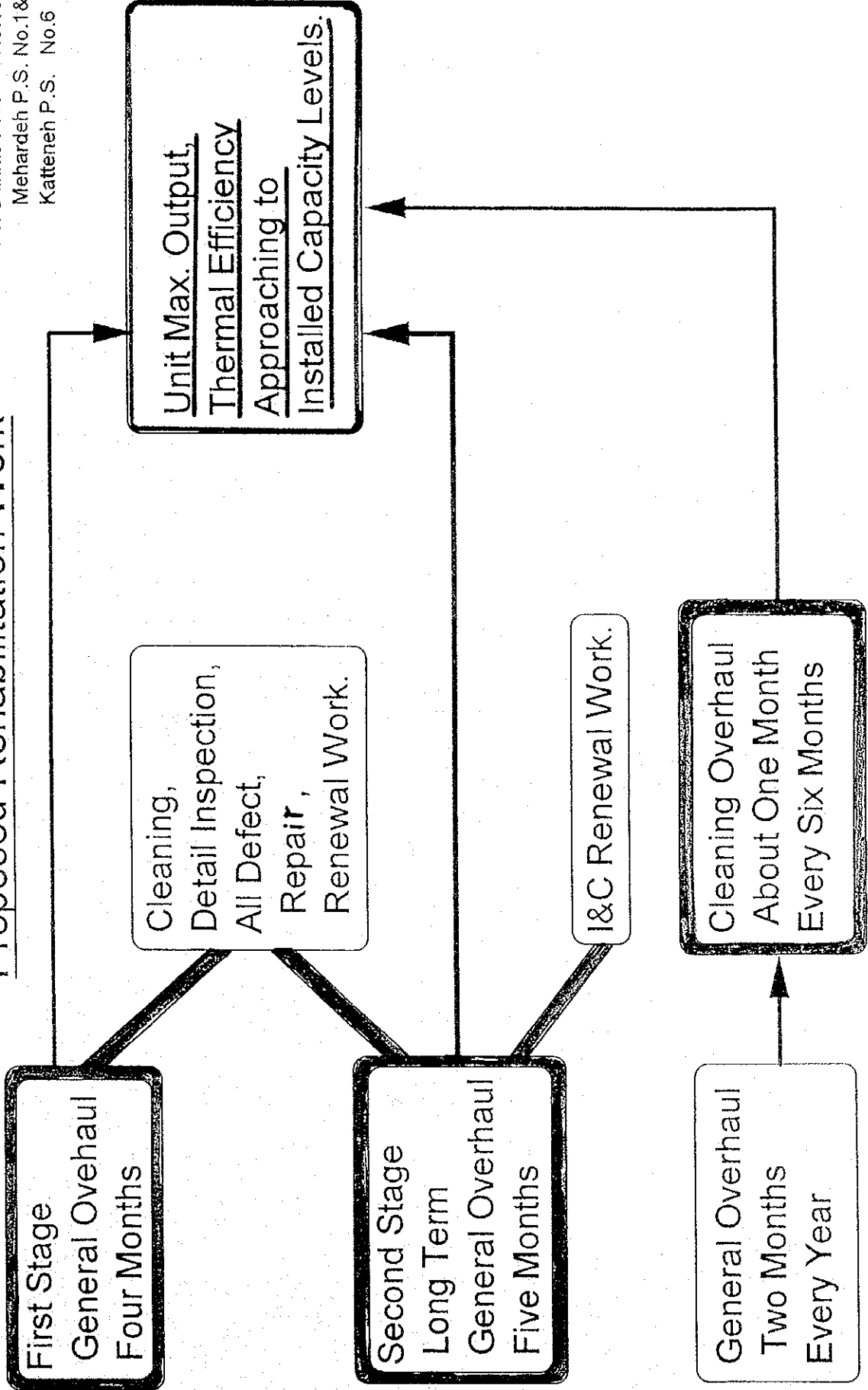
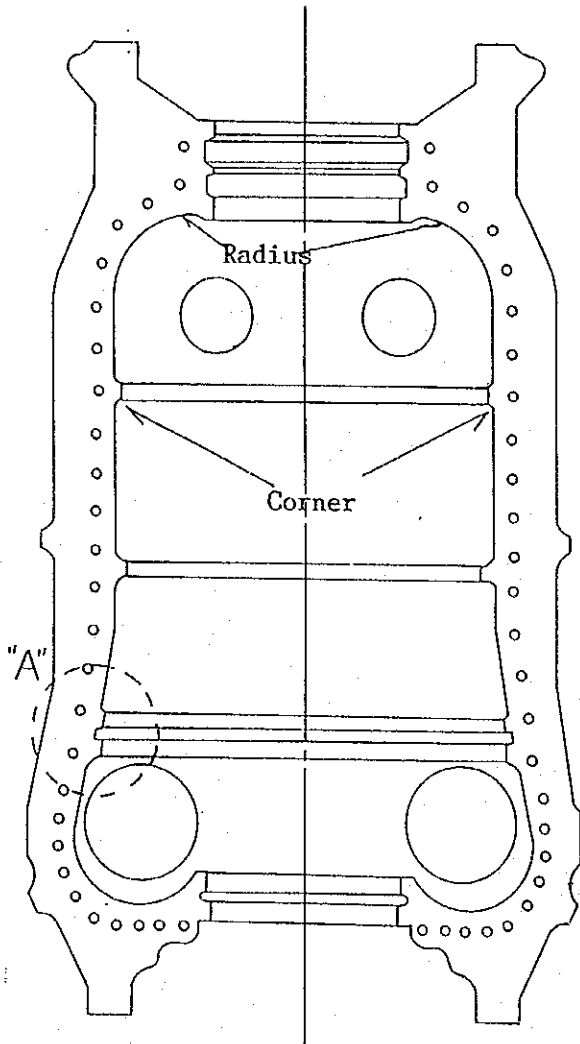

Fig:T-1

INSPECTION ON TURBINE CASINGS

1) High- Pressure Outer Casing



Descriptions:

Liquid penetrant test and magnetic particle test shall be applied to the inner surface of outer casing totally and as for inner casing the tests shall be applied to the both inner and outer surface totally.

And it is remarkable that at the radius part and corner of casing shall elaborately be inspected.

2) Midium- Pressure Casing

The same as above.

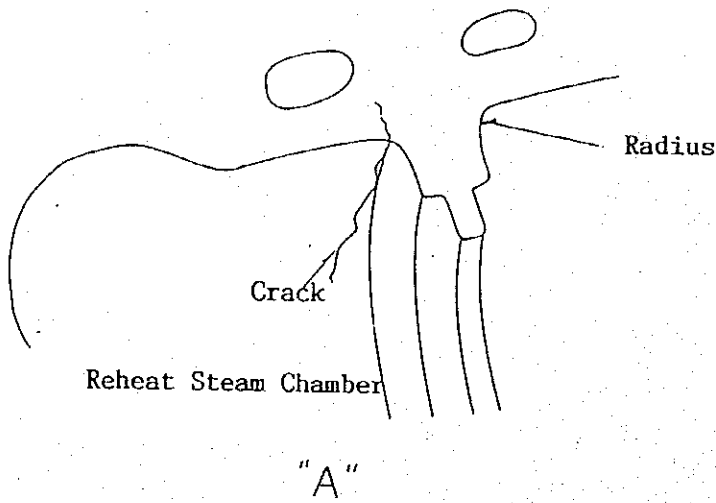

INSPECTION ON TURBINE CASINGS

3) High Pressure Inner Casing

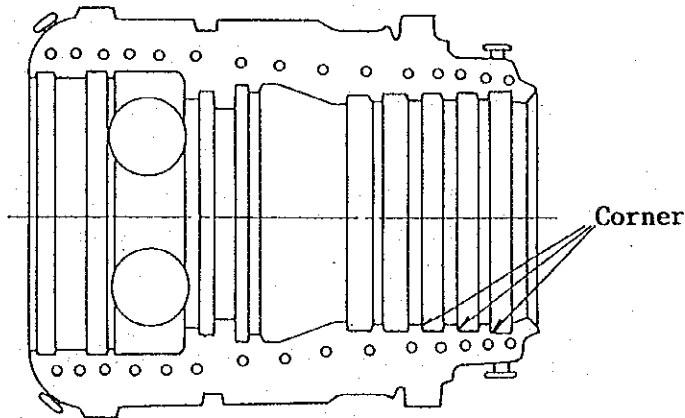

Descriptions:

Liquid penetrant test and magnetic particle test shall be applied to the inner surface of outer casing totally and as for inner casing the tests shall be applied to the both inner and outer surface totally.

And it is remarkable that at the radius part and corner of casing shall elaborately be inspected.

4) Structural Welded Portion

a) On high Pressure Casing

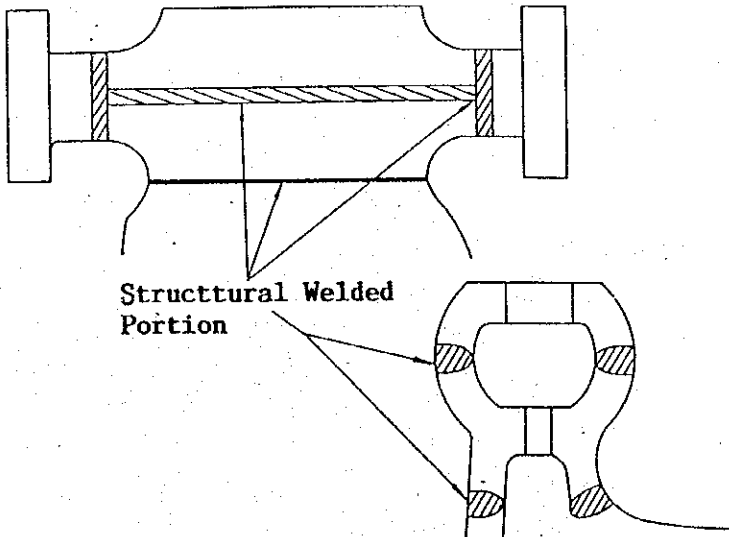

Descriptions:

Liquid penetrant test, magnetic particle test and ultrasonic flaw test shall be applied to the structural welded portions.

(All three tests are required to apply)

b) On Nozzle Box

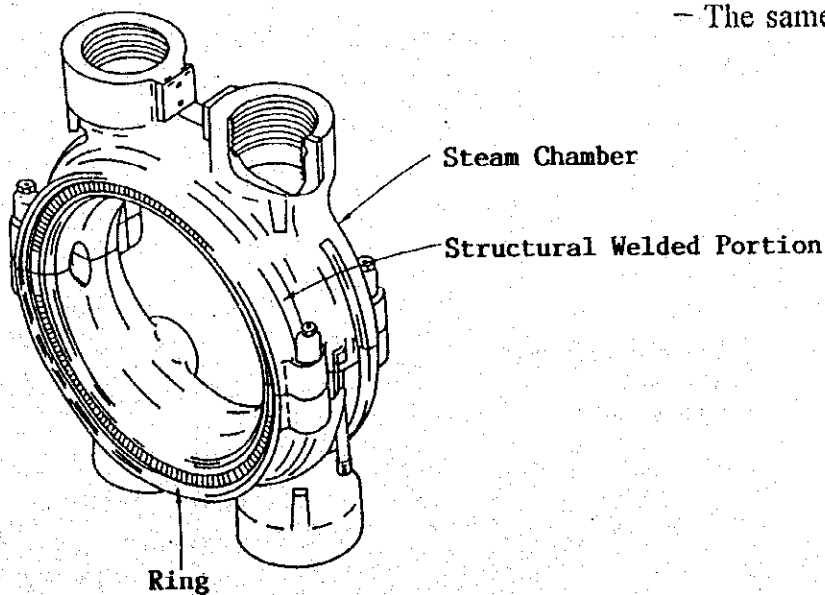

- The same as above. -

Fig:T-3

INSPECTION ON TIGHTENING BOLTS
AT HIGH TEMPERATURE AREA

1) Measurement of Hardness

An measurement shall be made to the points shown below by using shore-hardness meter or echo-chip meter.

In the case of measuring for stud bolts, it is required to take measure 5-times at each point by echo-chip meter and its mean value shall be represented in the shore hardness.

- ① In the case of a test applied to double-ended tightening bolt and taken-out stud bolt

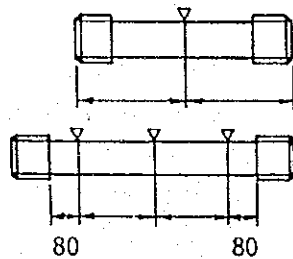

(Entire Length: Less than 500mm)

(Entire Length: More than 500mm)

- ② In the case of a test applied without removing stud bolt

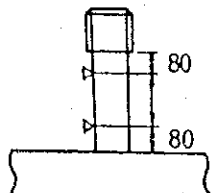

If the entire bolt length is less than 500 mm, measuring shall be applied at either point, upper or lower.

For the screw part, liquid penetrant test shall be applied .

2) Nondestructive Inspection

Checking the existence of cracks on screw part of bolt by ultrasonic flaw test shall be made. The Ultra Sonic Testing device will measure a defective echo.

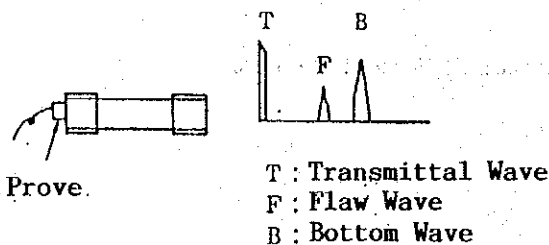

Probe.

T : Transmittal Wave
F : Flaw Wave
B : Bottom Wave

Fig:T-4

INSPECTION ON NOZZLE PLATES OF
HIGH/MIDIUM NOZZLE DIAPHRAM

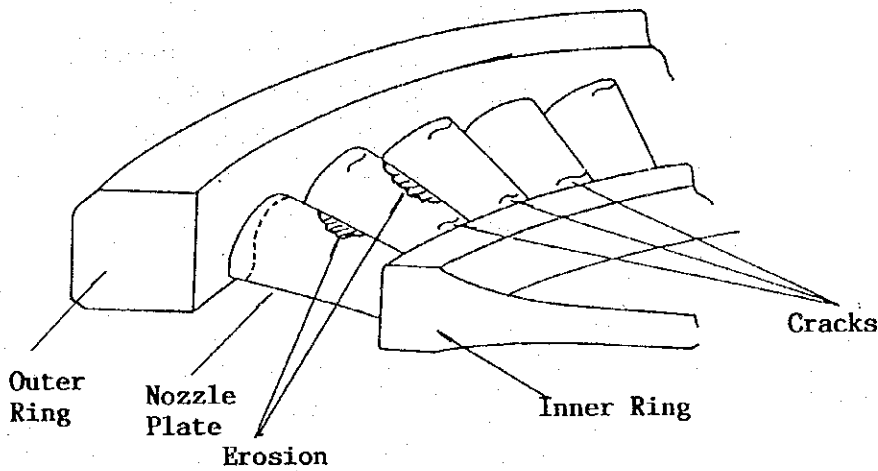

Descriptions:

Liquid penetrant test shall be applied to the steam passage on nozzles which is tend to be damaged oftenly with erosion.

Especially,high pressure and midium pressure nozzles at the initial stage shall eleborately be inspected.

Possible cracks occur in the area as shown in the sketch below should be inspected carefully.

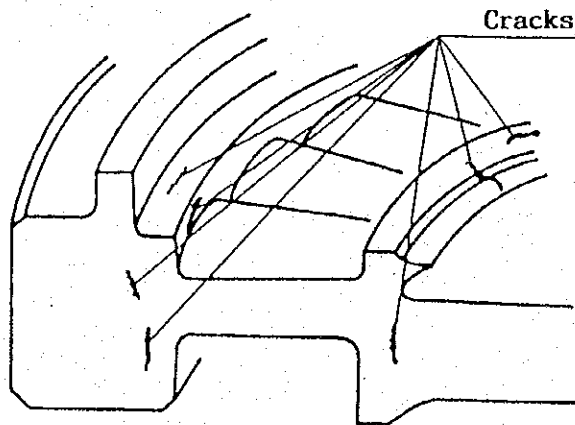

INSPECTION ON TURBINE BLADES

1) Creep at the Stud of High Temperature Blades

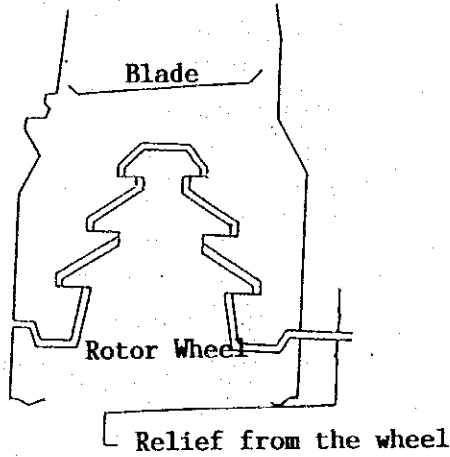

Descriptions:

A variation of clearance between wheel and blade bottom should be checked at every periodical inspections and precision inspections.

2) Tenon

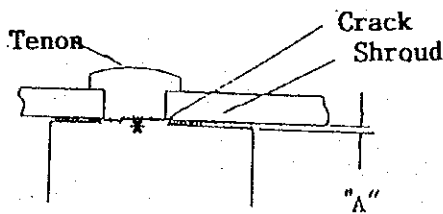

Descriptions:

Ruptured part can be found by measuring the clearance between blade shoulder and shroud, "A".

* Rupture around the tenon bottom

3) Bottom Gaps Between Detent-End Blade-Adjustment Liner

Minimum gaps between wheel and blade bottom of all five shall be measured by using gap gauge.

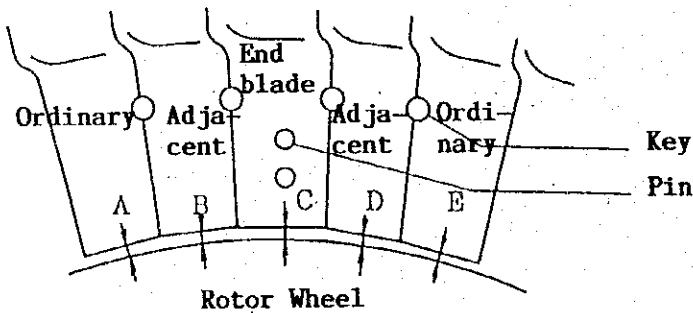

4) Difference at Pin-key Holes

Maximum gaps at pin-key for all stages shall be measured by using gap gauge.

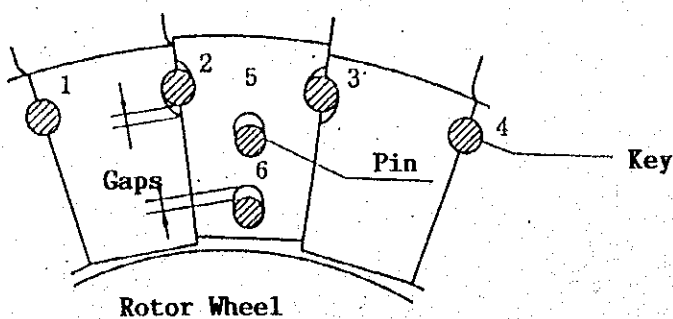

INSPECTION ON TURBINE BLADES

5) Cracks at the Stud of High Temperature Blades

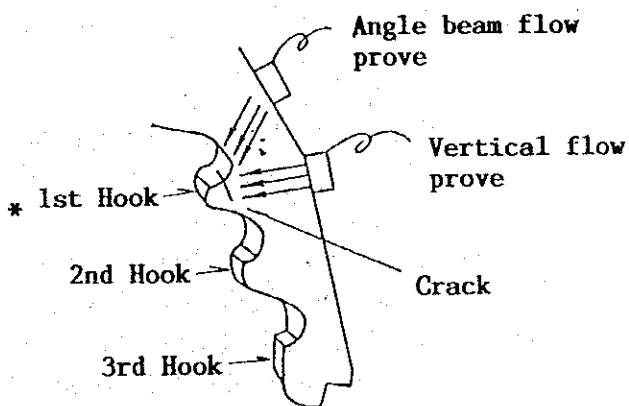

Descriptions:

Cracks shall be inspected by ultra sonic angle beam and vertical prove up to 3rd stages of high pressure and midium pressure blade.

* Cracks can oftenly occur at the 1st hook.

6) Damage on Locking Pin at Final Stage Blade

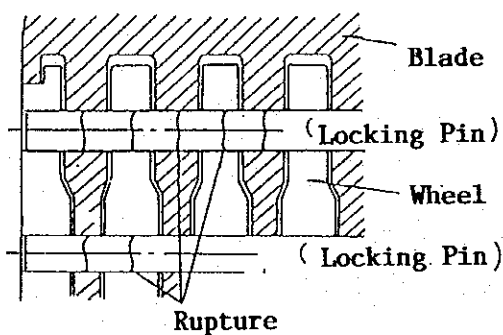

Descriptions:

The damage can be found perfectly by ultrasonic flaw test at periodical inspection.

7) Cracks and Erosion on Erosion Shield Plate at the Final Stage Blade

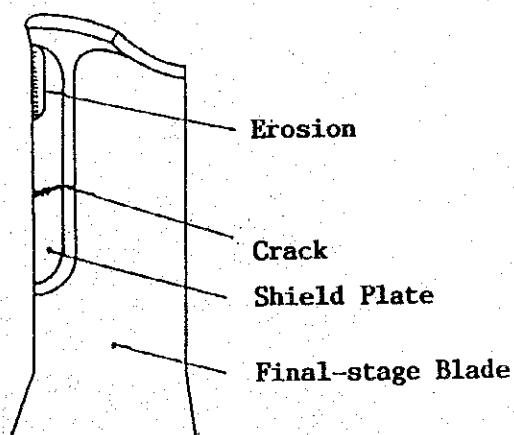

Descriptions:

Inspection given by visual and liquid penetrant test shall be applied elaborately.

Fig:T-7

INSPECTION ON TURBINE ROTOR HEAT GROUP

Descriptions:

Generally, liquid penetrant test shall be applied after honing to the rotor.

For giving an elaborative inspection, magnetic particle test shall be applied with polishing the heat and labyrinth group of high pressure and midium pressure.

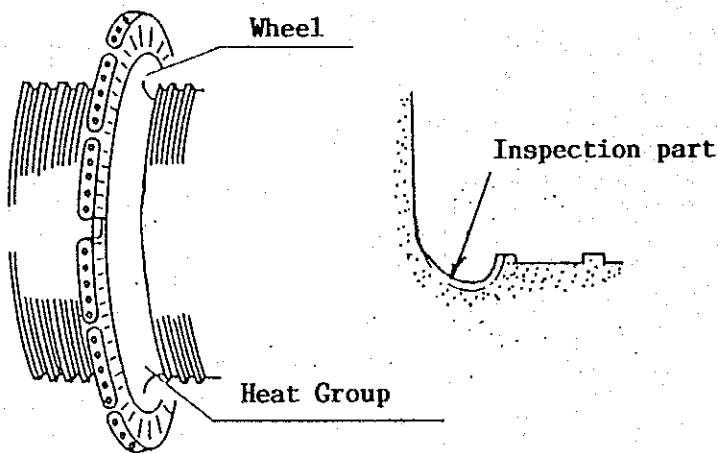

INSPECTION ON TURBINE ROTOR CENTER BORE

1) Magnetic Particle Test

Fixing an aluminium pipe into the bore(hole),injecting the current on it with spraying magnetic particle liquid. Thereafter, it should be checked existence of crack or cavity by using bore scope.

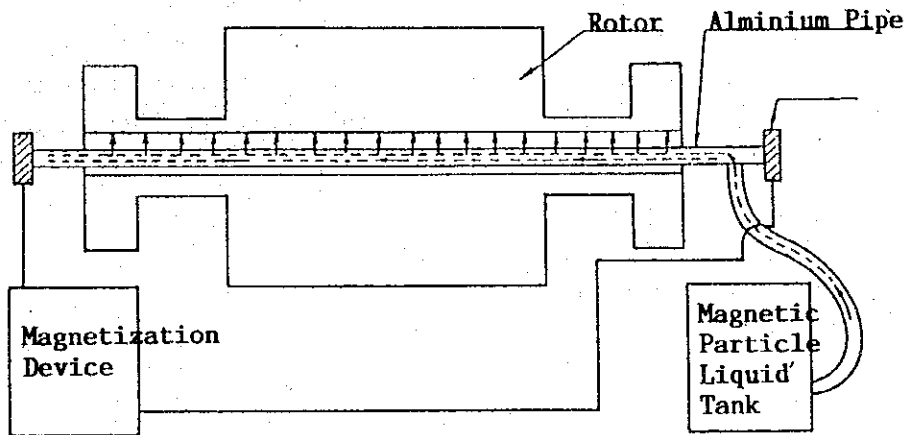

2) Ultrasonic Flaw Inspection

Inserting a special prove into the bore in rotor and observe the condition inside the bore by ultrasonic flaw testing device or television camera. Video record can also be made.

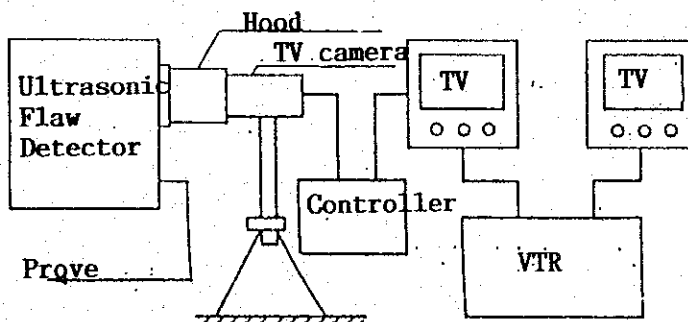
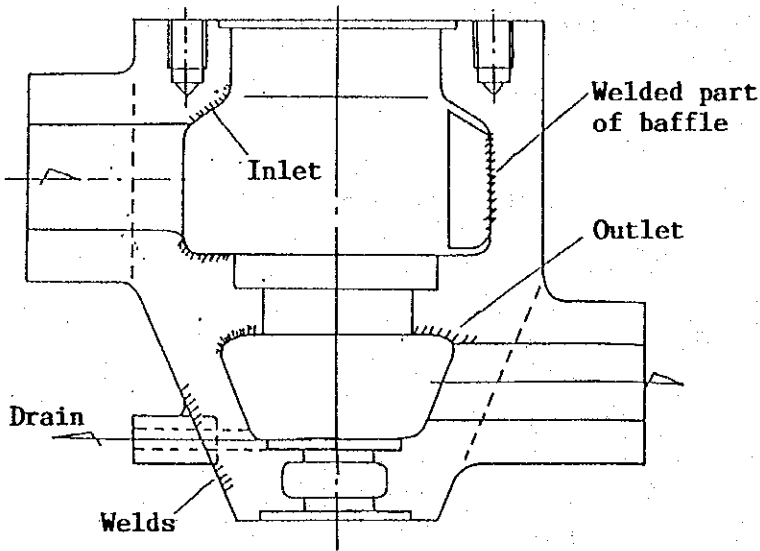

Fig:T-9

MAIN STOP VALVE

1) Main Body



Descriptions:

Liquid penetrant test shall be applied to the valve casing inner surface totally. And horizontal face on valve cover fixing and touching face of gasket shall be inspected with liquid penetrant test and magnetic particle test.

2) Structural Welded Part on Main Stop Valve

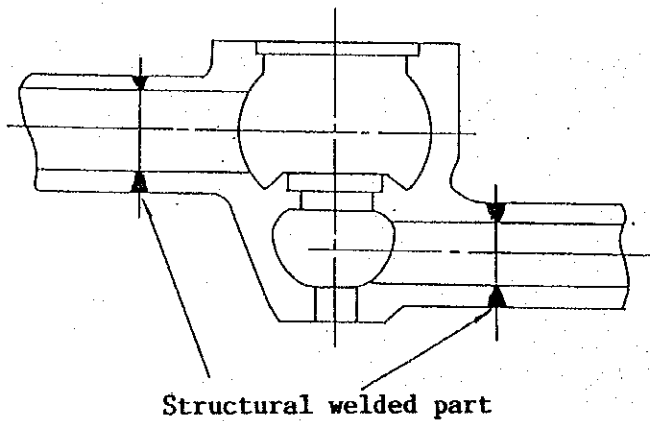

Descriptions:

Liquid penetrant test, magnetic particle test and ultrasonic flaw test shall be applied to the structural welded part. As for the welds of baffleplate and the welds on drain pipe fixing base shall be inspected with liquid penetrant test and magnetic particle test.

Fig:T-10

FEED WATER HEATER

1) Sealing Welded Part on High Pressure Heating Tube and Tube Plate

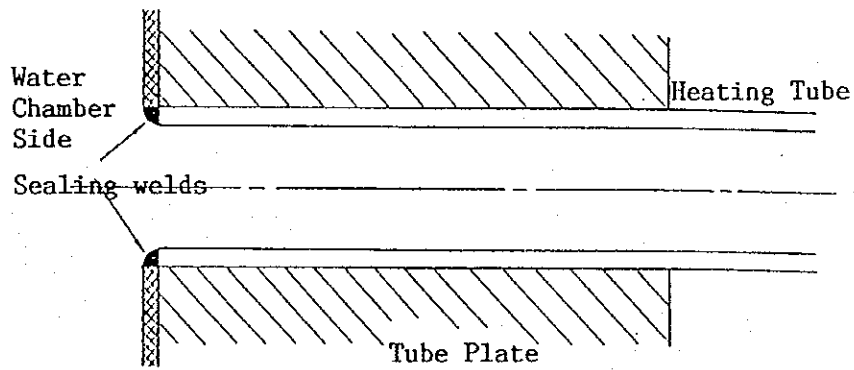

Descriptions:

Liquid penetrant test shall be applied to the sealing welded part on heating tube and tube plate.

Eddycurrent test shall be applied to the heating tube totally. (Whole condenser tubes shall also be inspected with eddy-current test.)

2) High Pressure Heater Chamber

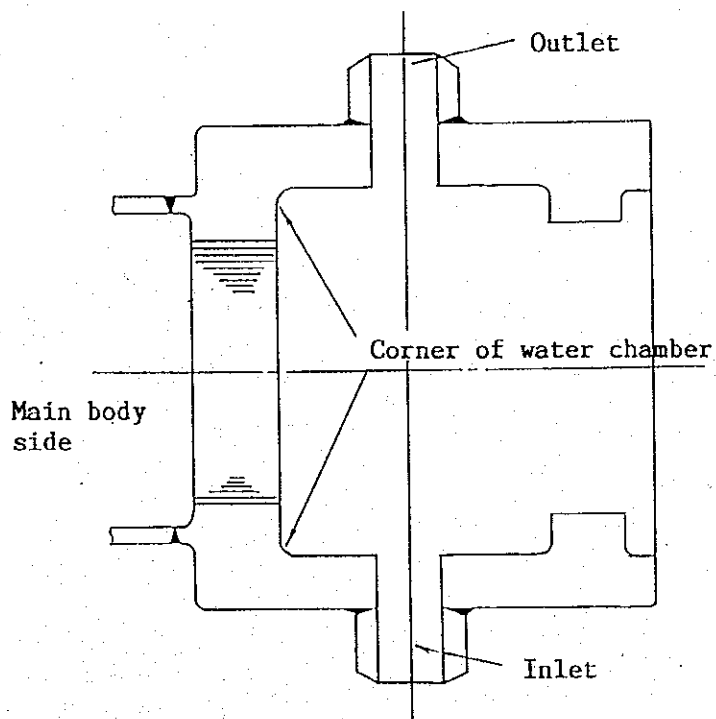

Descriptions:

Liquid penetrant test shall be applied to the corner of water chamber.

(74/76)

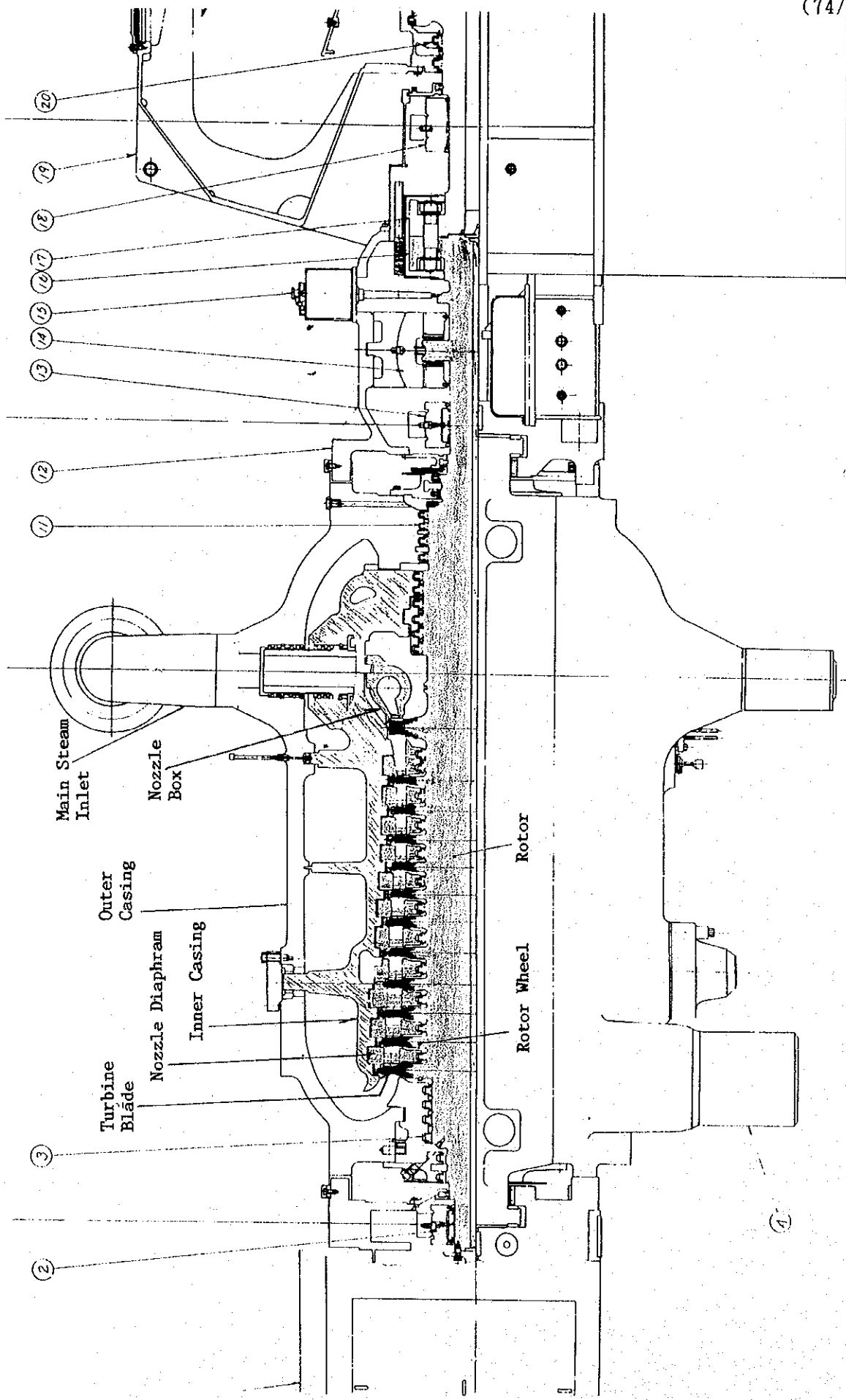

- SECTION -
1) HIGH PRESSURE TURBINE

Dwg: T-1

(75/76)

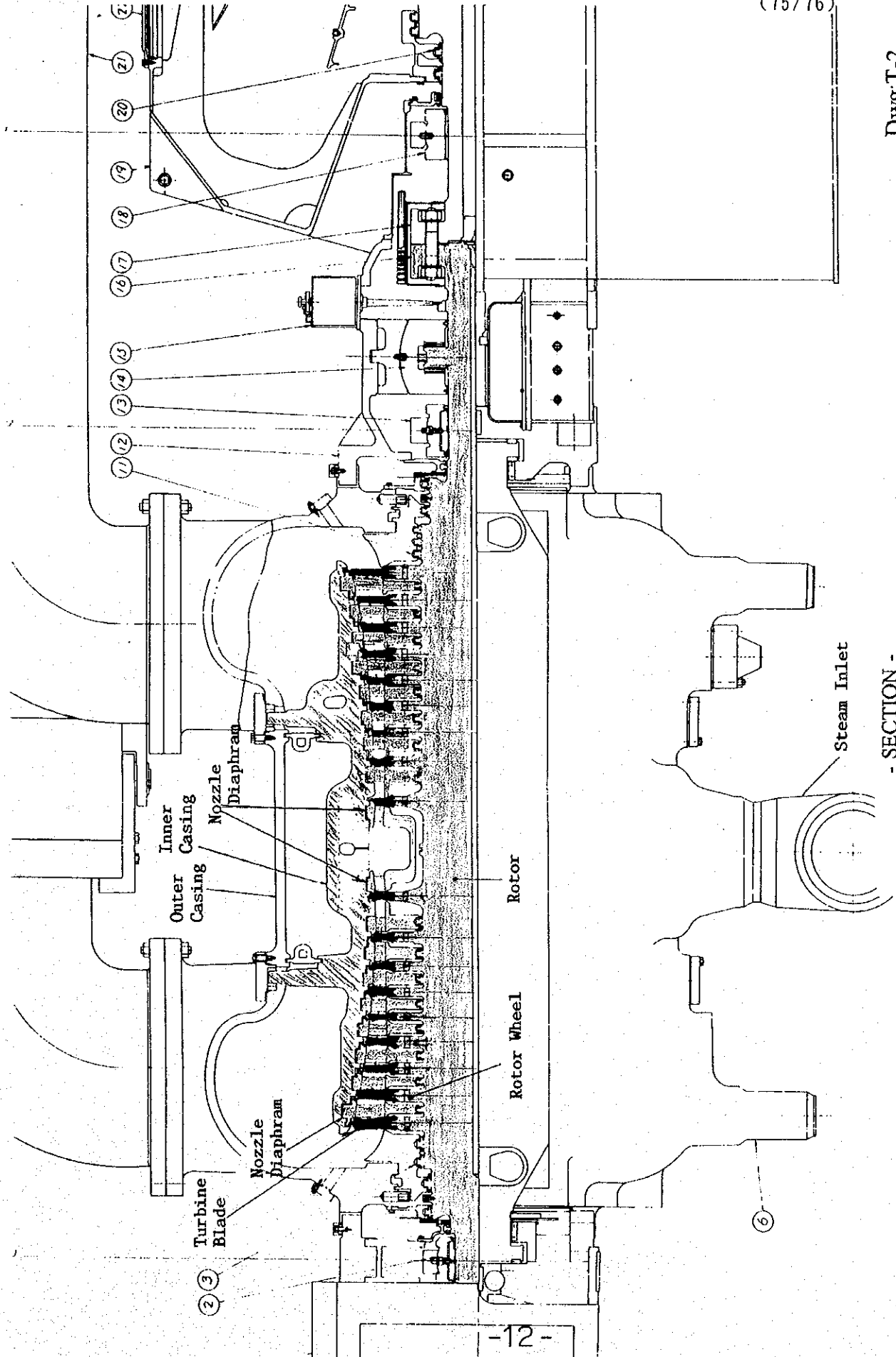

Dwg:T-2

SECTION -
2) MEDIUM PRESSURE TURBINE

(76/76)

Dwg:T-3

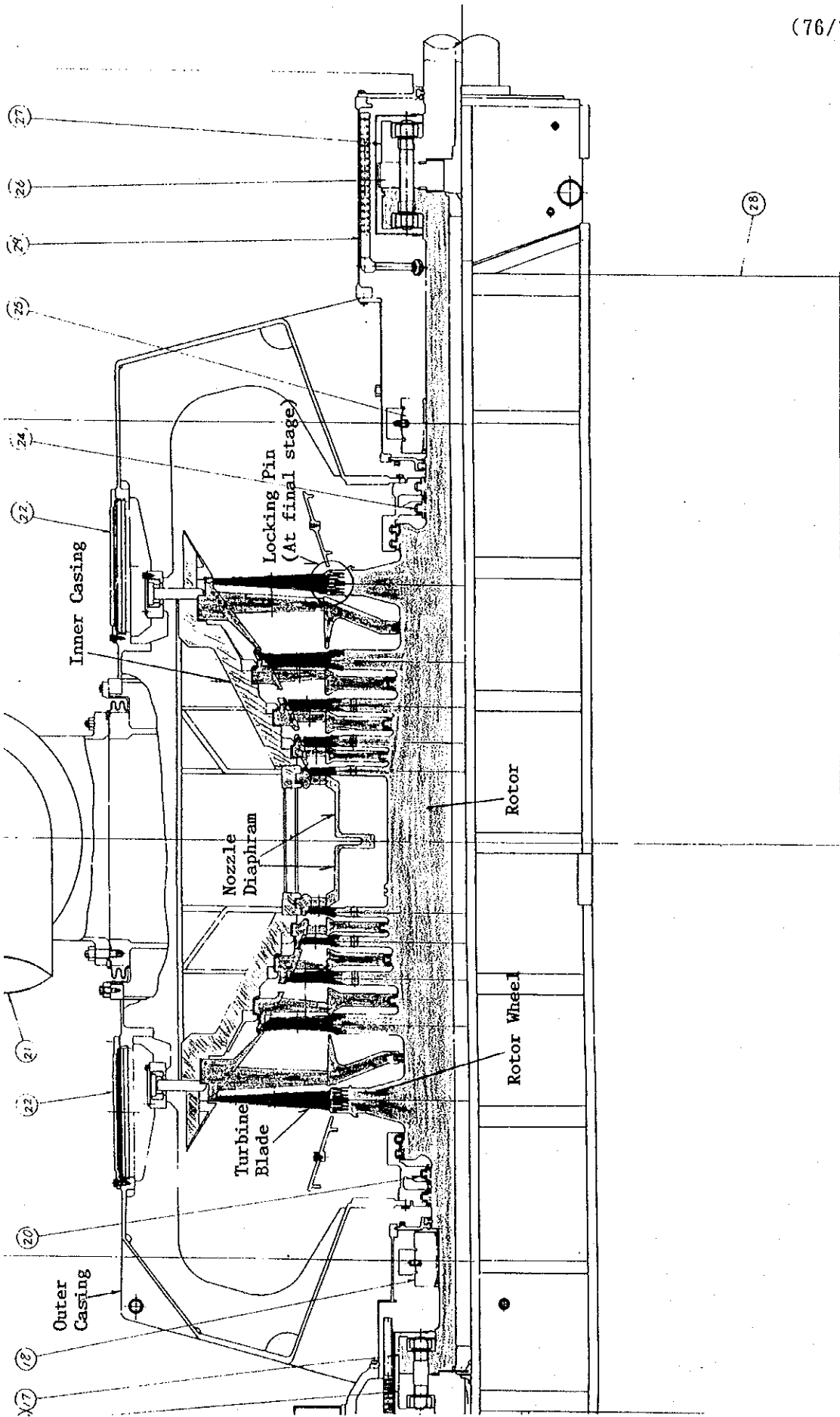

- SECTION -
3) LOW PRESSURE TURBINE