

検討工作物
MG 10100、 ベッド

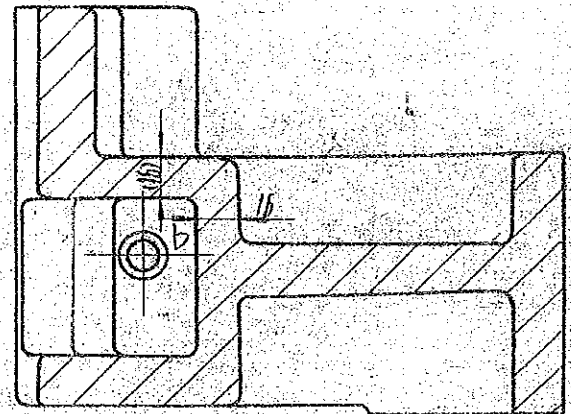
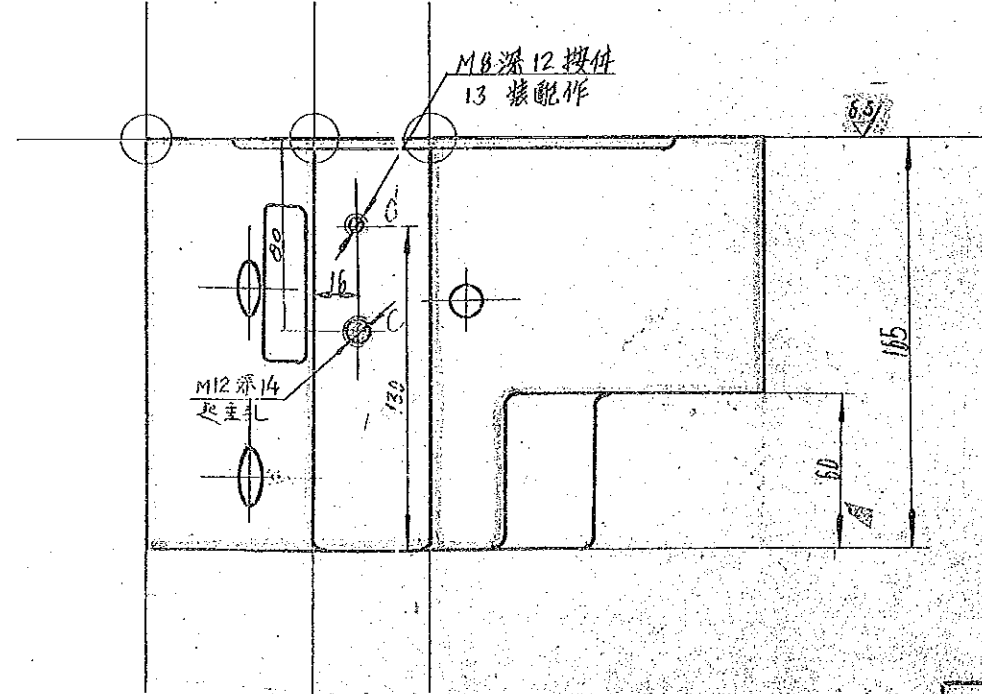
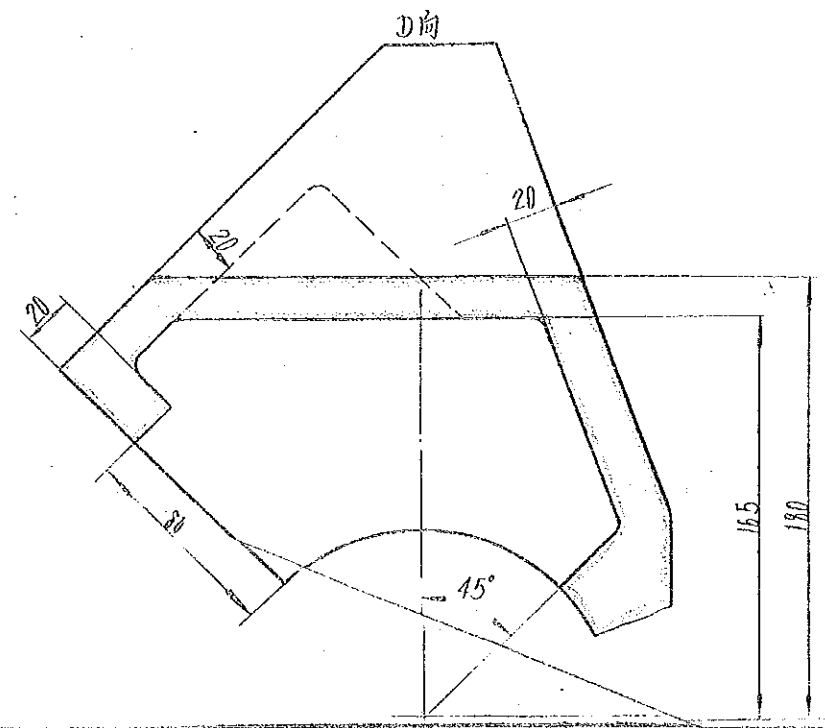
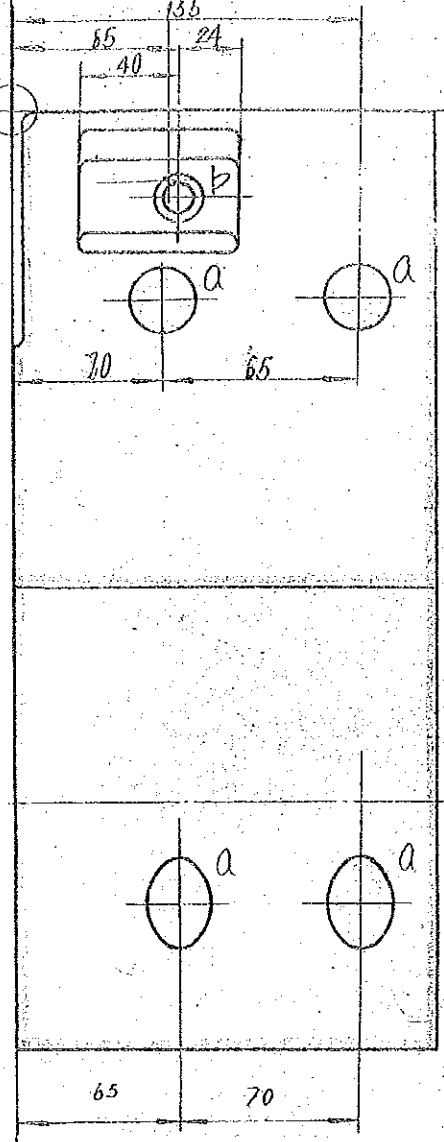
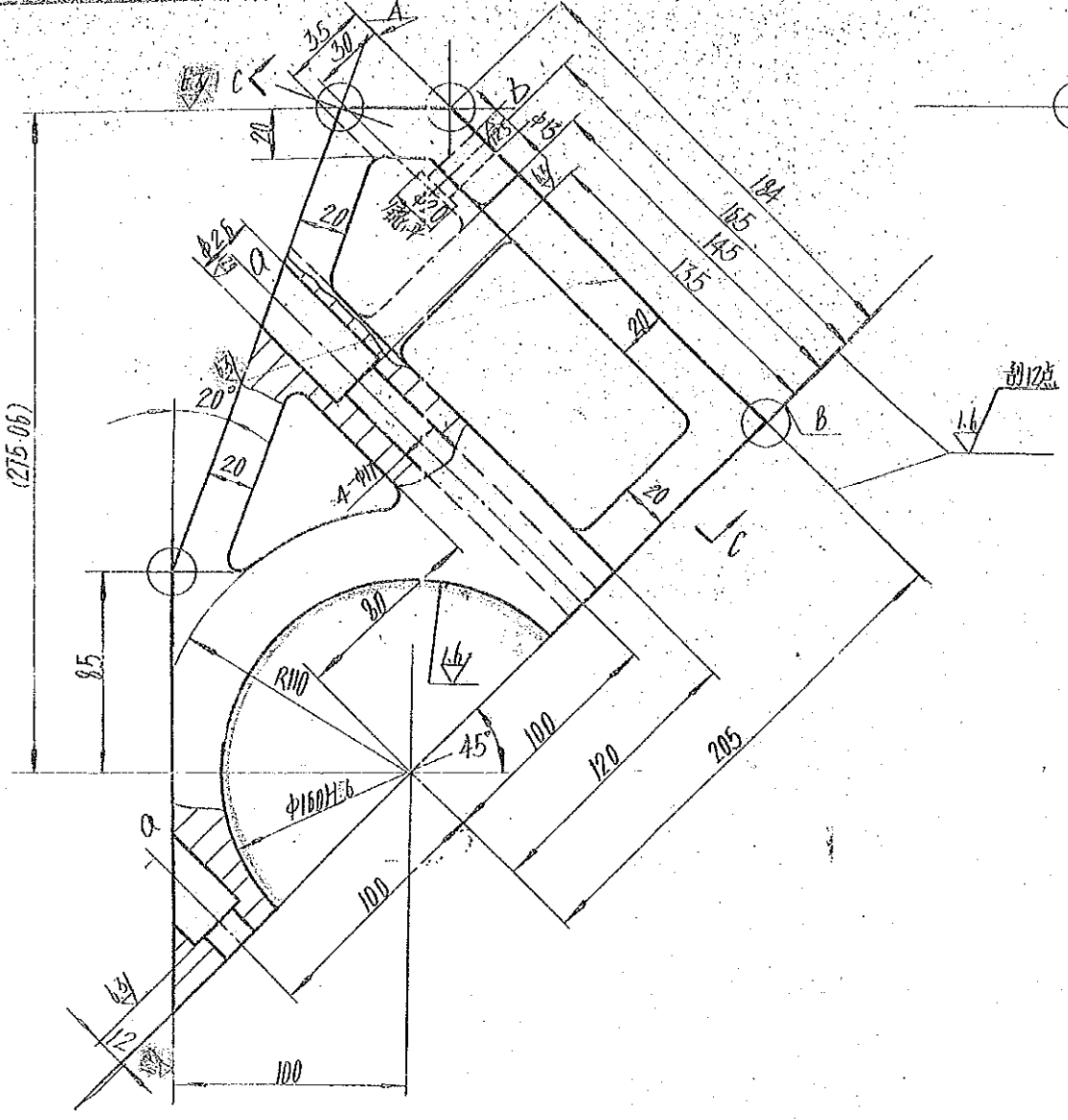
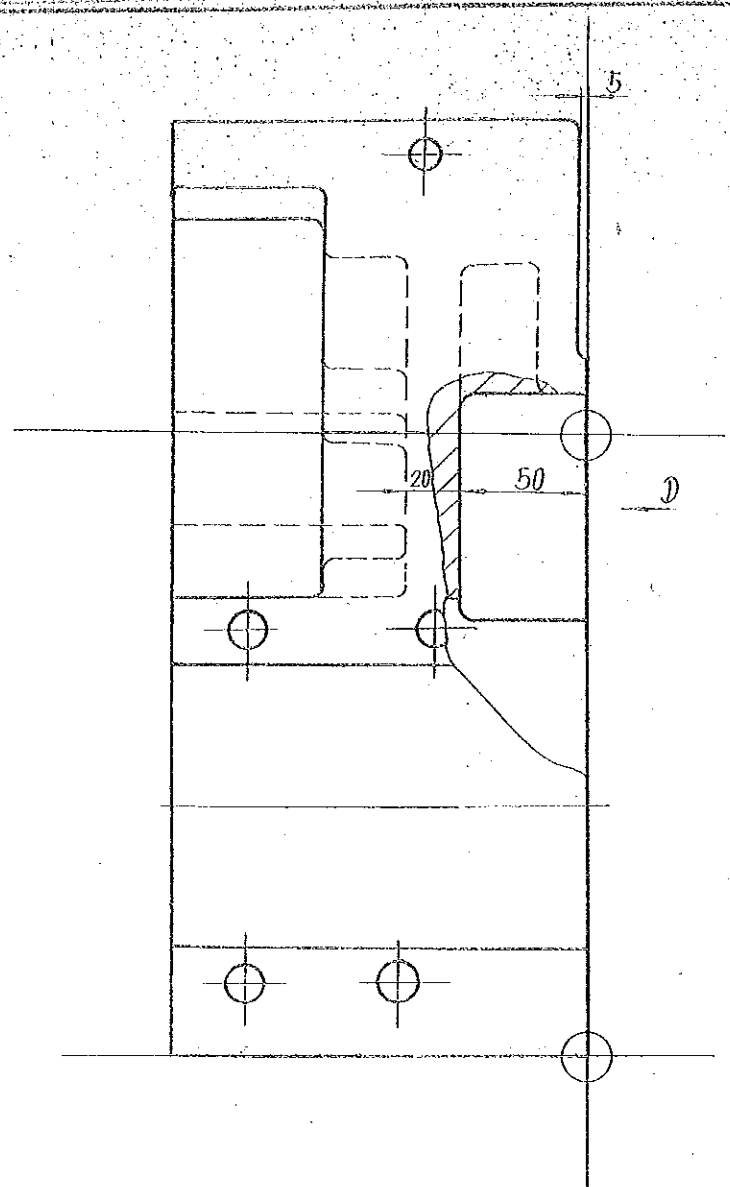

技术要求
1. A面及B面与件02
配制前按图于M10
上加工$\phi 160H6$孔。
2. 时效。

检讨工作物 (2)
MG 10100、轴体

注: 未注明铸造圆角 $R3 \sim 8$。

检用	俞美君	标准化专员	冯贤杰	行轴承盖	MG10100
制附	全露良	产品工艺师	吴志庆		M1150 11
检用	陈华	产品设计师	陈协章	无锡机床厂	150 17

