

HIS MAJESTY'S GOVERNMENT OF NEPAL
MINISTRY OF WORKS AND TRANSPORT
DEPARTMENT OF ROADS

**THE STUDY
ON
KATHMANDU VALLEY URBAN ROAD DEVELOPMENT
FINAL REPORT
PART B : FEASIBILITY STUDY**

DRAWINGS

MARCH 1993

JAPAN INTERNATIONAL COOPERATION AGENCY

S	S	F
C	R	(3)
93-046(5/5)		

HIS MAJESTY'S GOVERNMENT OF NEPAL
MINISTRY OF WORKS AND TRANSPORT
DEPARTMENT OF ROADS

**THE STUDY
ON
KATHMANDU VALLEY URBAN ROAD DEVELOPMENT**

**FINAL REPORT
PART B : FEASIBILITY STUDY**

DRAWINGS

MARCH 1993

JICA LIBRARY



1119417121

JAPAN INTERNATIONAL COOPERATION AGENCY

国際協力事業団

27554

LIST OF DRAWINGS

	<u>Page</u>
New Bagmati Bridge	
Plan (1).....	1
Plan (2) Thapathali Intersection.....	2
Plan (3) Kopundol Intersection.....	3
No.2 Bridge (New Bagmati Bridge).....	4
No.2 Pedestrian Bridge (Thapathali Side).....	5
South Link of Inner Ring Road	
Plan and Profile (1).....	6
Plan and Profile (2).....	7
Plan and Profile (3).....	8
Typical Cross Section.....	9
Cross Section (1).....	10
Cross Section (2).....	11
Cross Section (3).....	12
Cross Section (4).....	13
Cross Section (5).....	14
No.1 Bridge.....	15
No.3 Bridge.....	16
No.1 Pedestrian Bridge (Patan Side).....	17
Sanepa Access and Patan Access	
Plan and Profile.....	18
Typical Cross Section.....	19
Cross Section (1).....	20
Cross Section (2).....	21

	<u>Page</u>
Koteswor Access	
Plan and Profile (1)	22
Plan and Profile (2)	23
Typical Cross Section	24
Cross Section (1)	25
Cross Section (2)	26
Cross Section (3)	27
No.4 Bridge	28
 Central Bus Terminal Access	
Plan and Profile (1)	29
Plan and Profile (2)	30
Typical Cross Section	31
Cross Section (1)	32
Cross Section (2)	33
Cross Section (3)	34
 Structures (1)	 35
Structures (2)	36
Utilities (1)	37
Utilities (2)	38
Utilities (3)	39
Utilities (4)	40

ABBREVIATIONS

ABBREVIATION	FULL WORDS
STA.	STATION
R	RADIUS OF CURVATURE
BP	BEGINNING OF ROUTE
BC	BEGINNING OF CIRCULAR CURVE
EC	END OF CIRCULAR CURVE
EP	END OF ROUTE
V.C.R	RADIUS OF VERTICAL CURVE
V.C.L	VERTICAL CURVE LENGTH
FH	FORMATION HEIGHT
GH	GROUND HEIGHT
C-P \emptyset L	PIPE CULVERT \emptyset : DIAMETER, L : LENGTH
C-B-B H L	BOX-CULVERT B : WIDTH, H : HEIGHT, L : LENGTH

LEGEND

DETAIL	SYMBOLS
PROPOSED ROUTE WITH CUT SLOPE & FILL SLOPE	
STONE MASONRY	
BRIDGE	
BOX-CULVERT & PIPE CULVERT	

NEW BAGMATI BRIDGE AND TWO JUNCTIONS

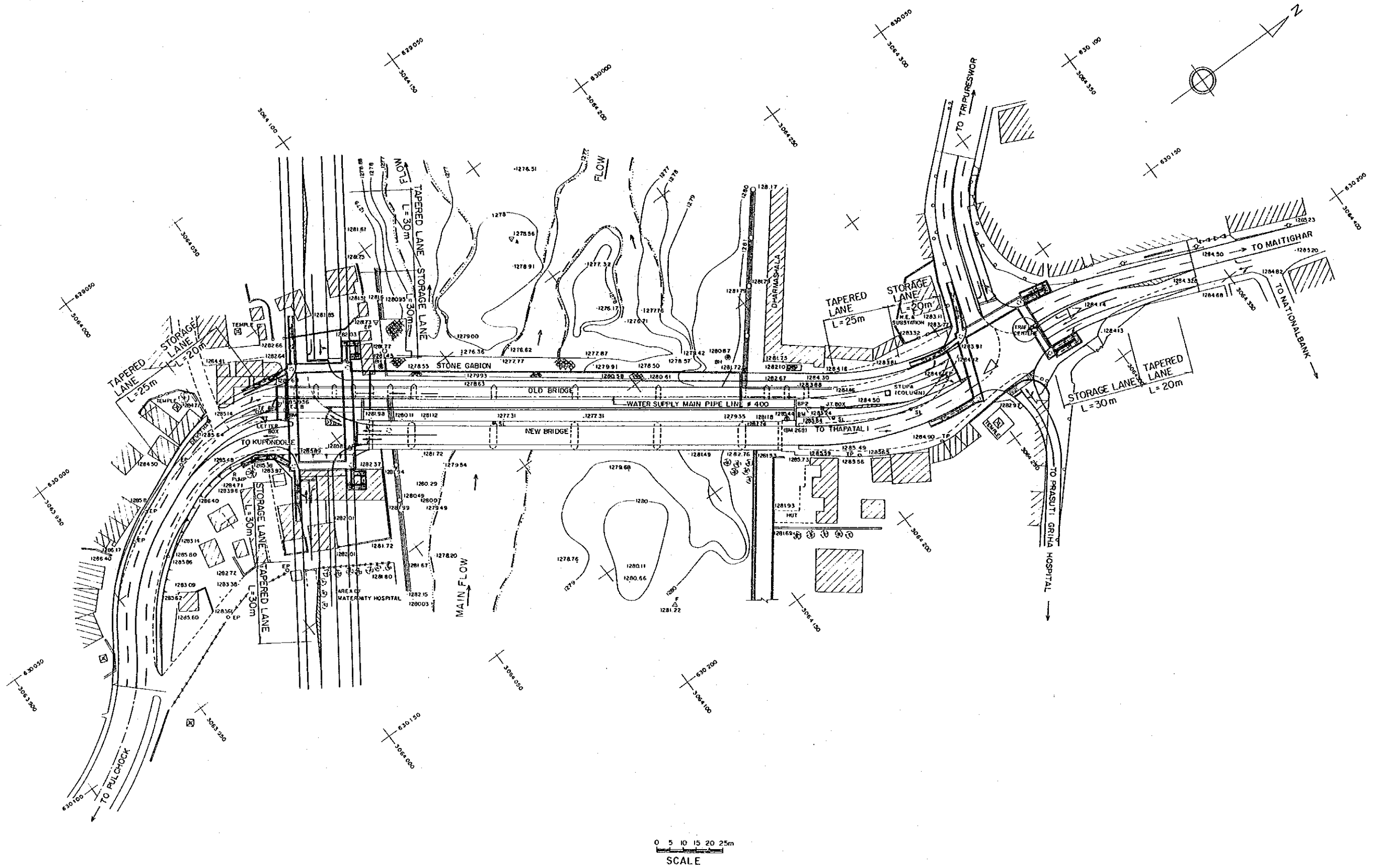

0 5 10 15 20 25m
SCALE

HIS MAJESTY'S GOVERNMENT OF NEPAL MINISTRY OF WORKS AND TRANSPORT DEPARTMENT OF ROADS	THE STUDY ON KATHMANDU VALLEY URBAN ROAD DEVELOPMENT	JAPAN INTERNATIONAL COOPERATION AGENCY	NEW BAGMATI BRIDGE PLAN (1)	DATE MARCH 1993	SHEET NO. 1 / 40
---	--	---	--------------------------------	-----------------------	---------------------

THAPATHALI JUNCTION SCALE 1 : 500

CI

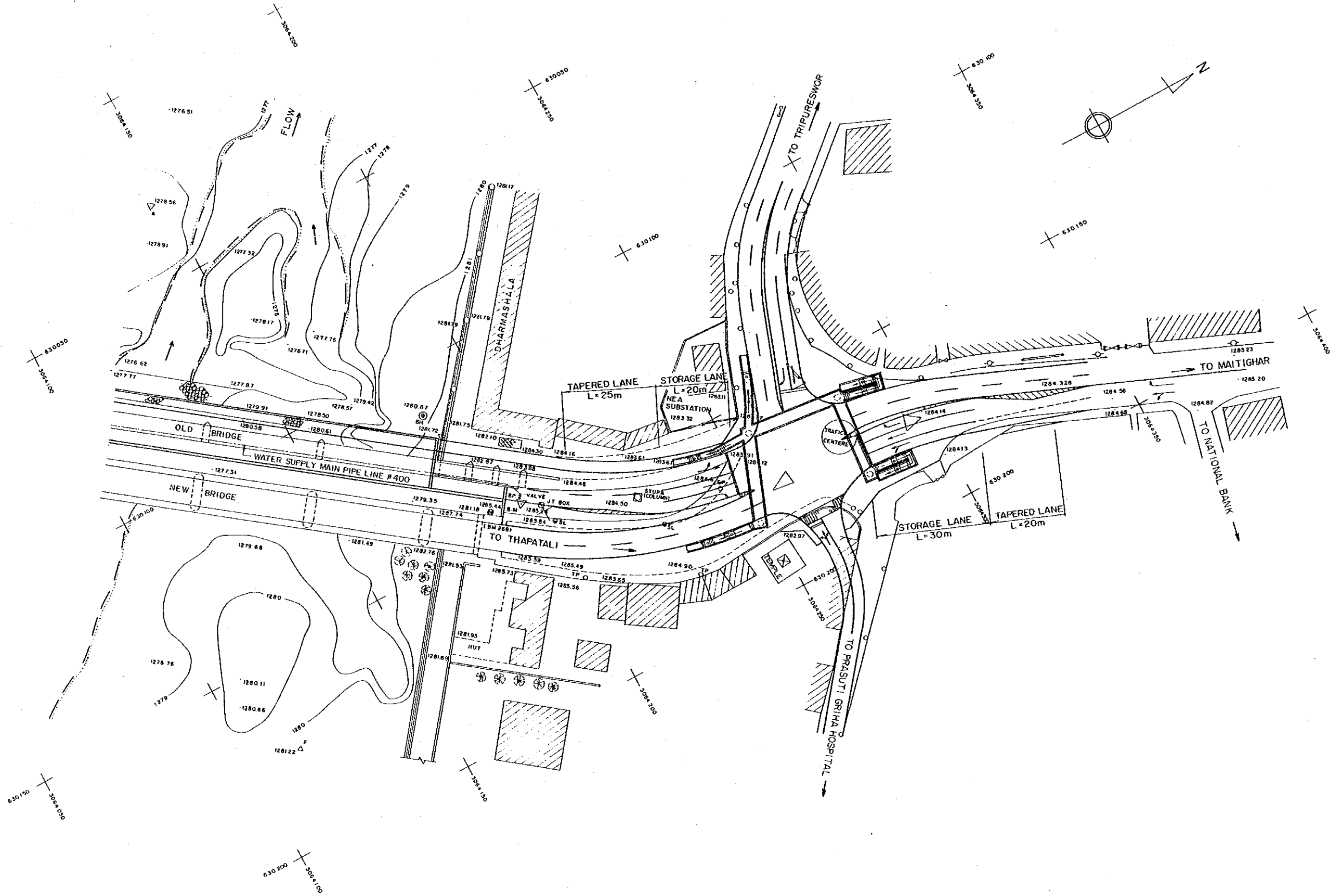

HIS MAJESTY'S GOVERNMENT OF NEPAL MINISTRY OF WORKS AND TRANSPORT DEPARTMENT OF ROADS	THE STUDY ON KATHMANDU VALLEY URBAN ROAD DEVELOPMENT	JAPAN INTERNATIONAL COOPERATION AGENCY	NEW BAGMATI BRIDGE	DATE	SHEET NO.
			PLAN (2) THAPATHALI INTERSECTION	MARCH 1993	2 / 40

KOPUNDOL JUNCTION SCALE 1 : 500
(PATAN SIDE)

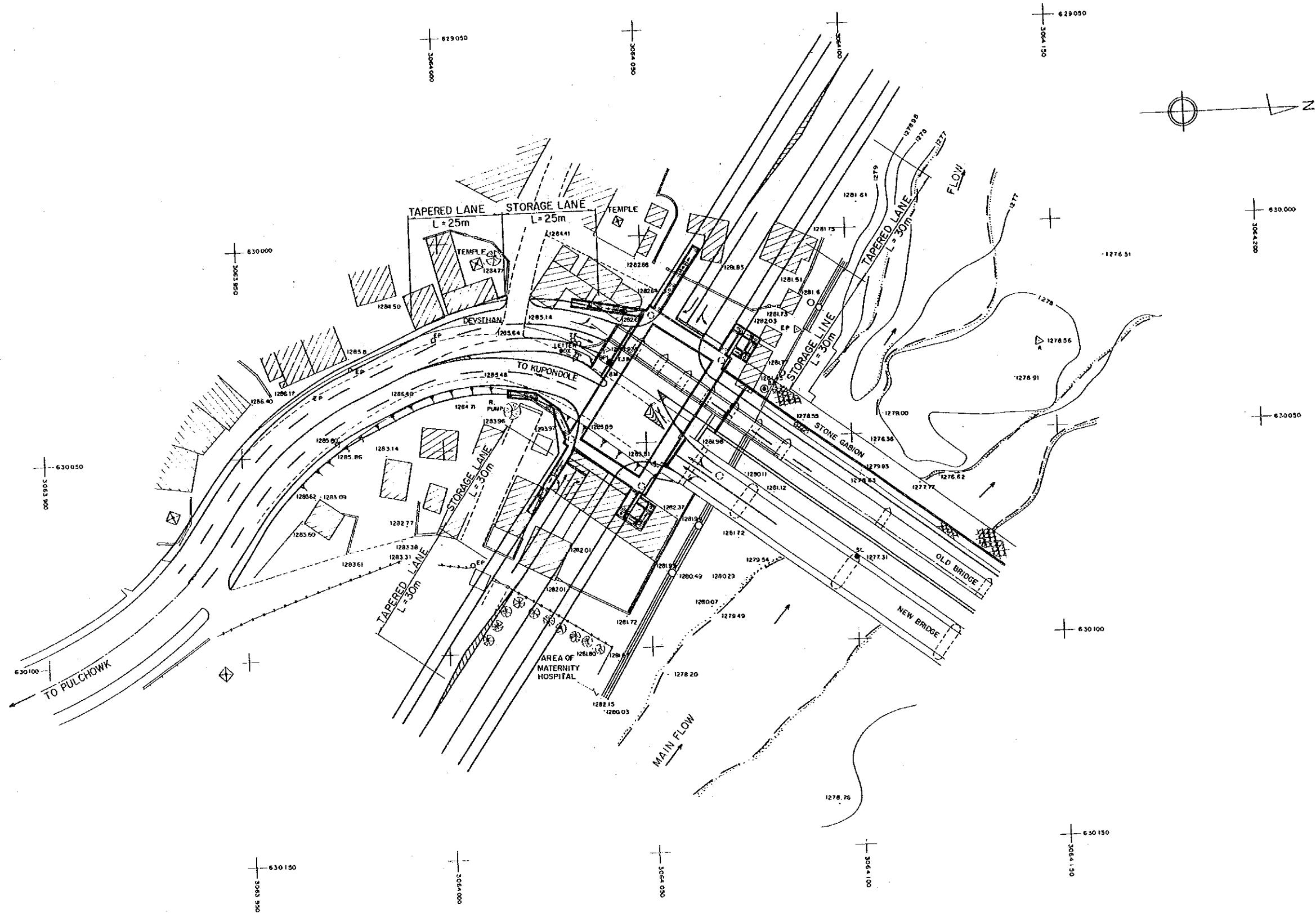

HIS MAJESTY'S GOVERNMENT OF NEPAL MINISTRY OF WORKS AND TRANSPORT DEPARTMENT OF ROADS	THE STUDY ON KATHMANDU VALLEY URBAN ROAD DEVELOPMENT	JAPAN INTERNATIONAL COOPERATION AGENCY	NEW BAGMATI BRIDGE	DATE	SHEET NO.
			PLAN (3) KOPUNDOL INTERSECTION	MARCH 1993	3 / 40

BAGMATI BRIDGE No.2

GENERAL ELEVATION

S = 1 : 500

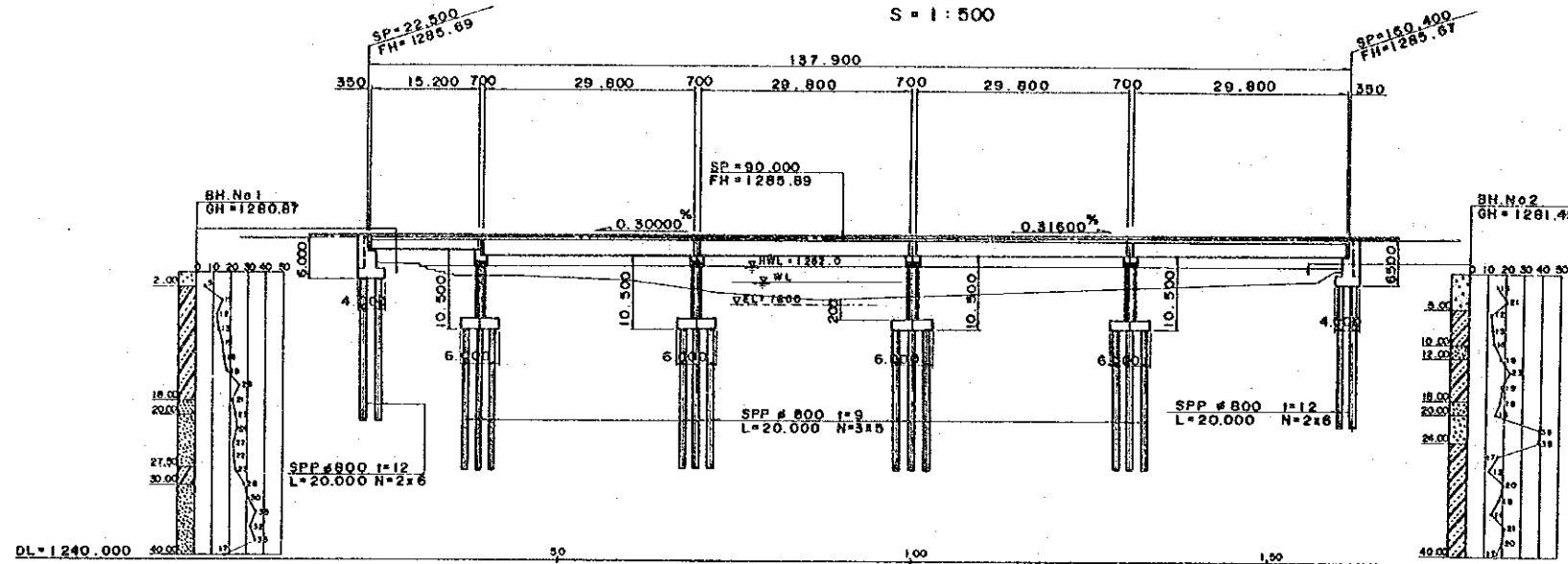

CROSS SECTION

S = 1 : 150

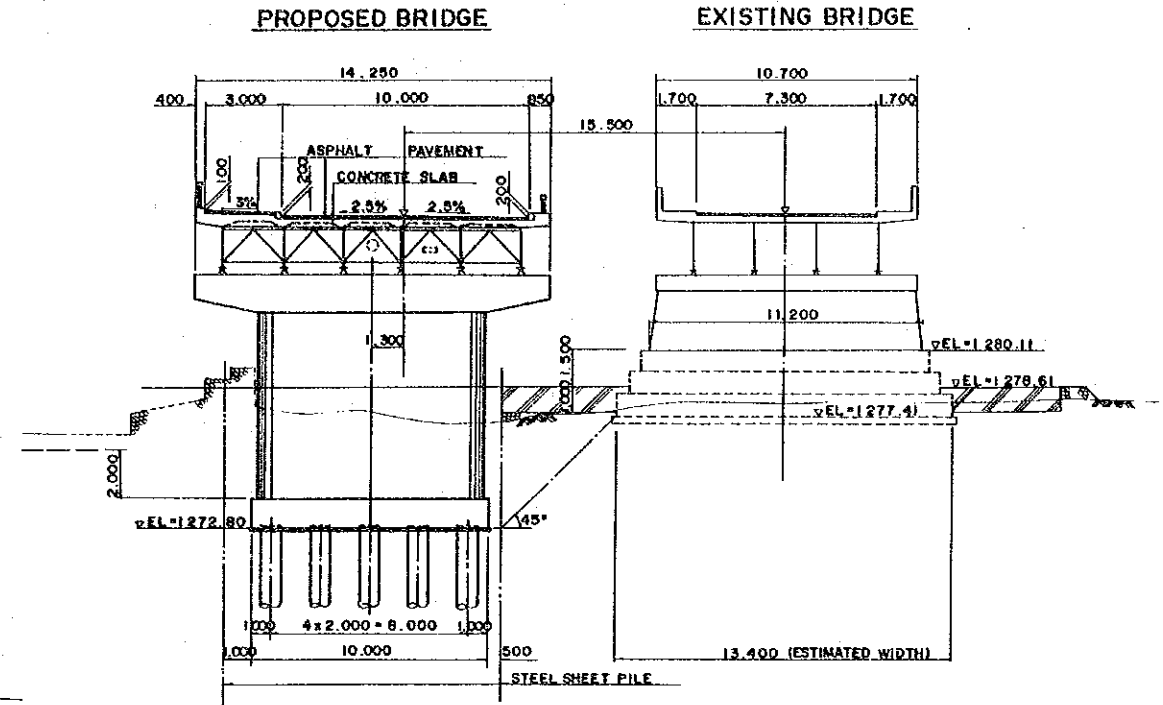

GENERAL PLAN

S = 1 : 500

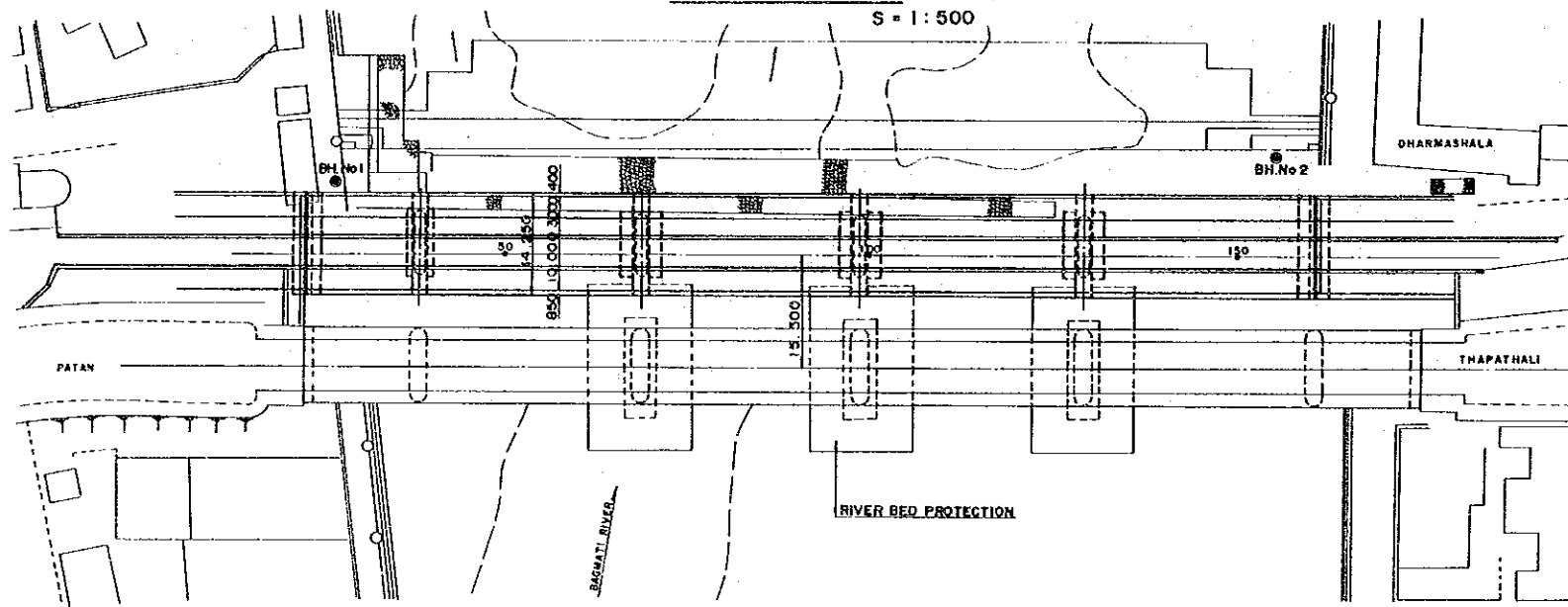

GENERAL ELEVATION

S = 1 : 500

EXISTING BRIDGE

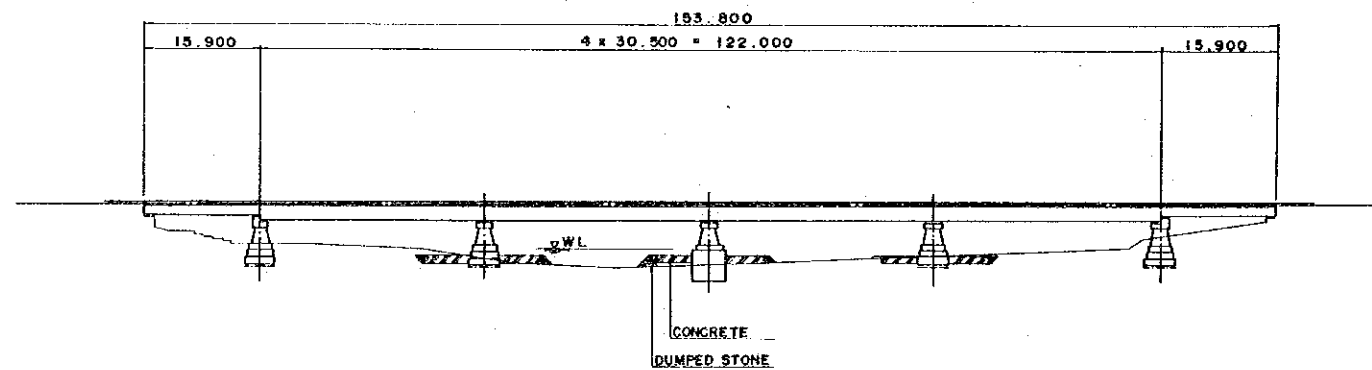

SECTION LOCATION: 25m D/S OF PROPOSED BRIDGE

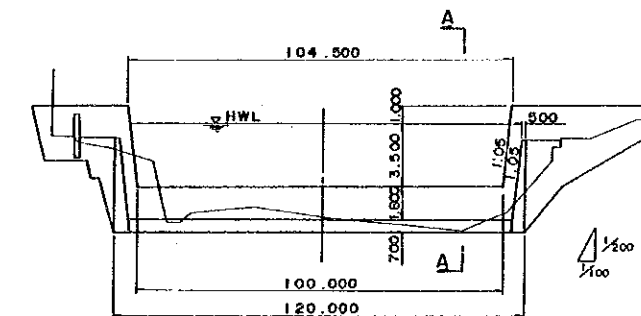

A - A

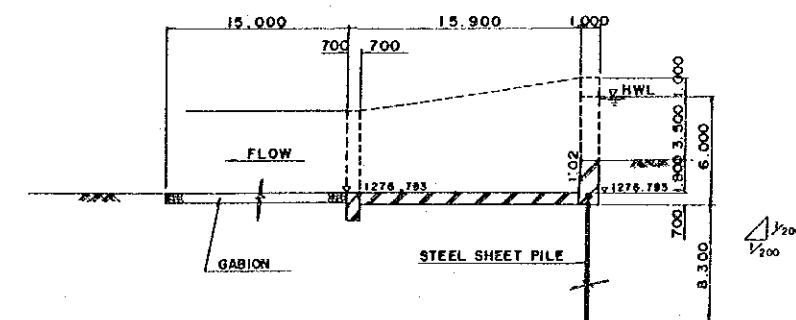

PEDESTRIAN BRIDGE No.2

GENERAL ELEVATION

S = 1 : 300

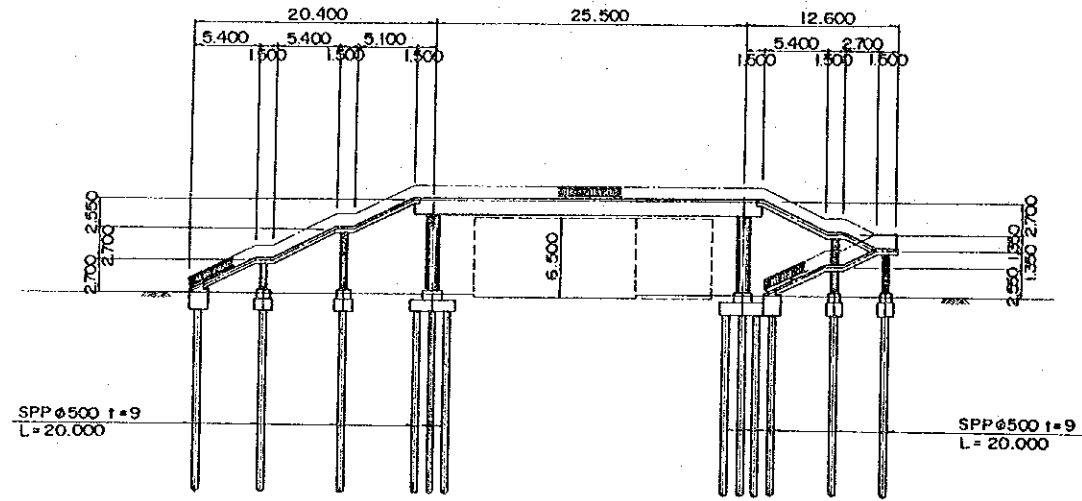

CROSS SECTION

S = 1 : 50, 1 : 40

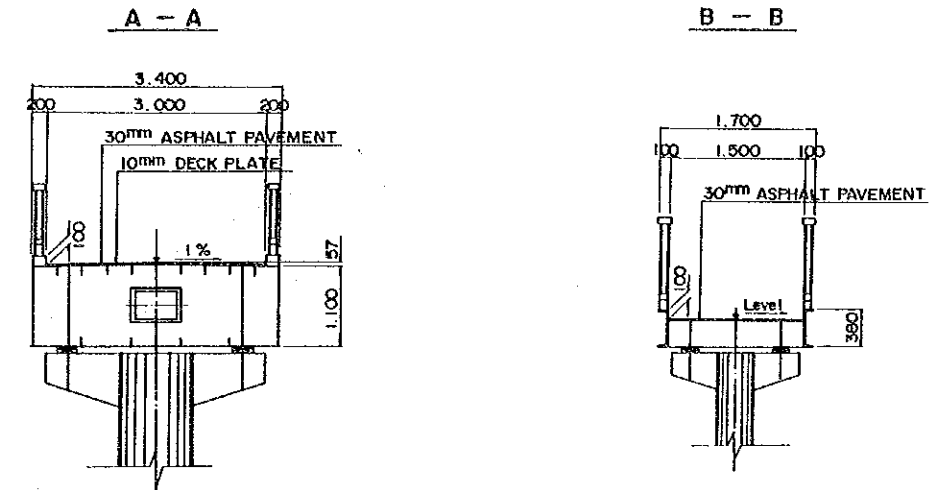

GENERAL PLAN

S = 1 : 300

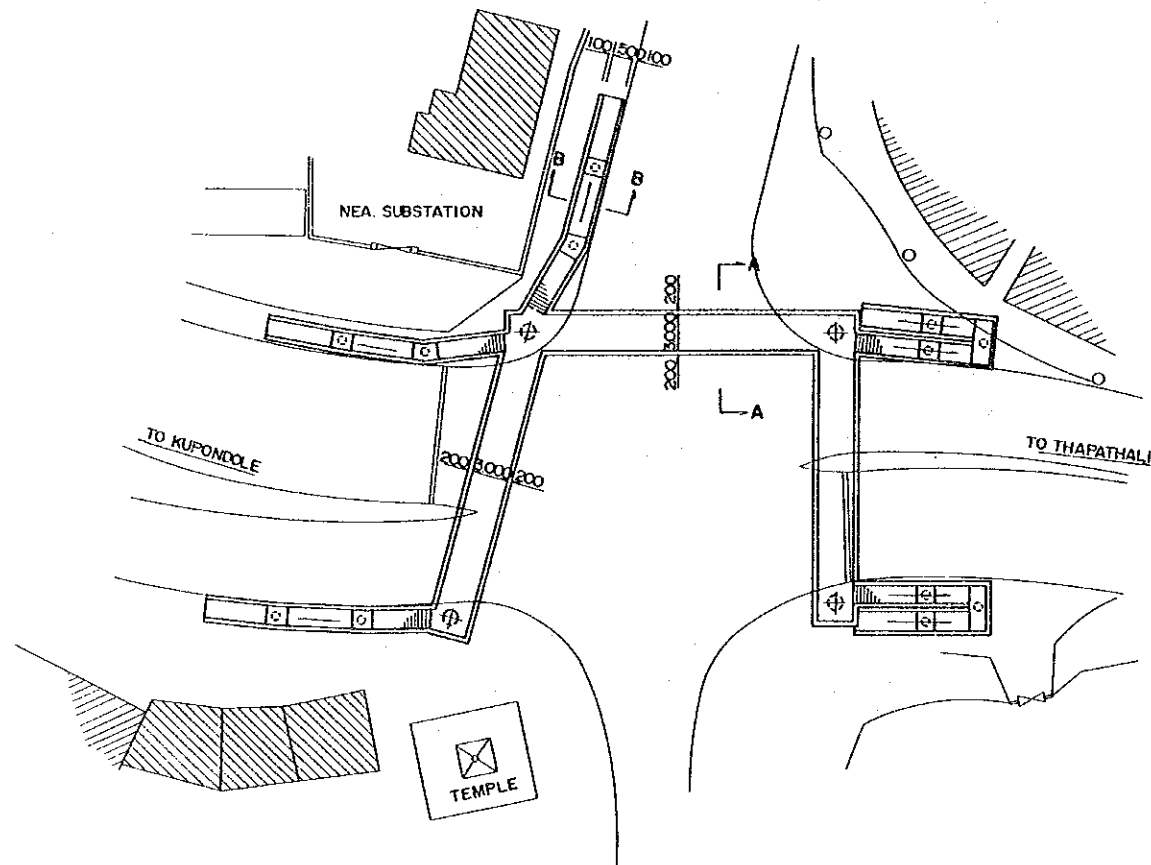

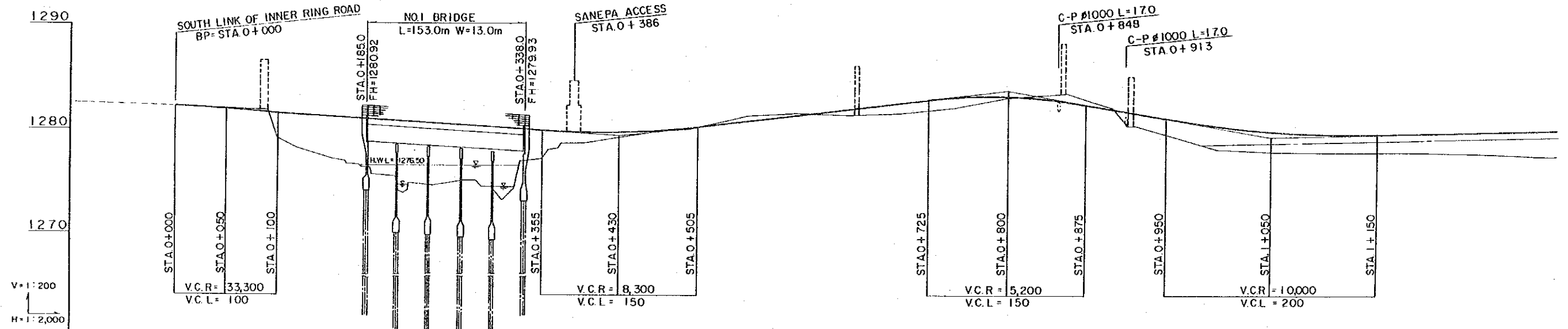
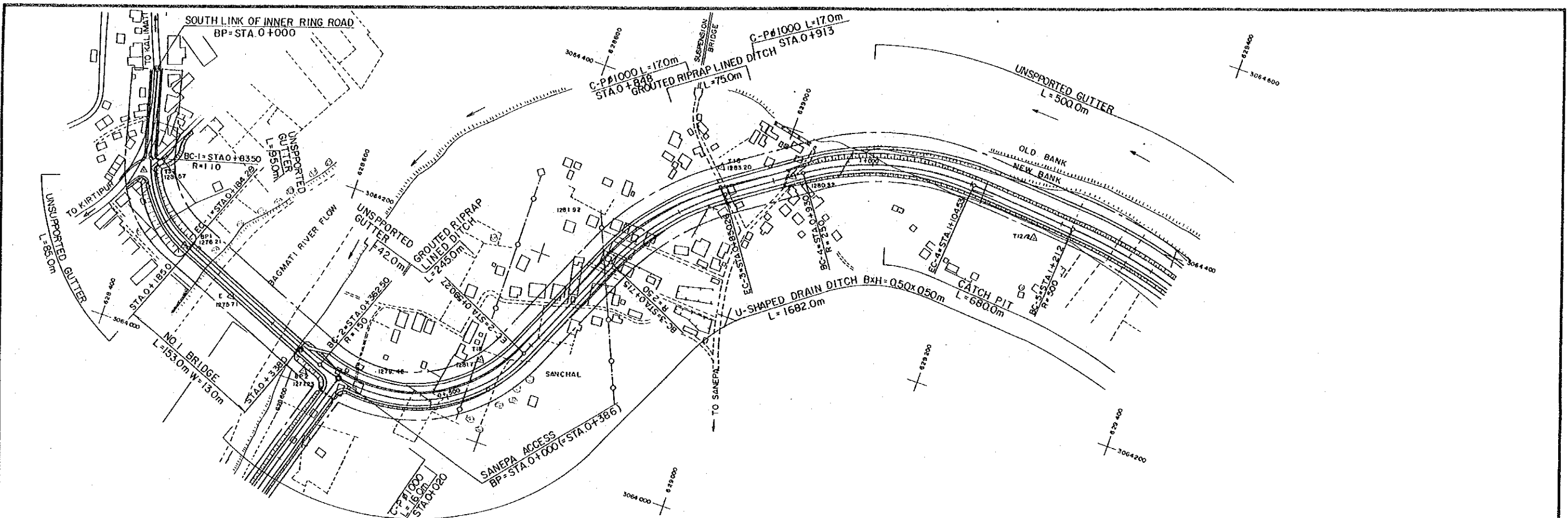

GRADIENT	-0.450%		-0.650%		1.160%		-1.750%		-0.450%																				
SUPER ELEVATION	-2.500%		-2.500%		-2.500%		-2.500%		-2.500%																				
FORMATION HEIGHT	1282.02	1281.76	1281.43	1281.05	1280.68	1280.50	1280.18	1279.55	1279.32	1279.40	1279.63	1280.46	1281.10	1281.73	1282.36	1282.93	1283.06	1282.69	1281.87	1281.00	1280.24	1279.74	1279.50	1279.50	1279.63	1279.75	1279.86		
GROUND HEIGHT	1282.02	1281.89	1279.00	1277.09	1275.50	1274.50	1274.40	1277.00	1278.60	1279.50	1280.00	1281.27	1281.50	1281.33	1281.50	1282.00	1283.00	1283.36	1282.00	1279.50	1278.80	1278.80	1277.80	1277.80	1277.80	1277.80	1277.70	1277.50	1277.50
STATION	0+000	50	100	150	200	250	300	350	400	450	500	550	600	650	700	750	800	850	900	950	1000	50	100	150	200	250	300		

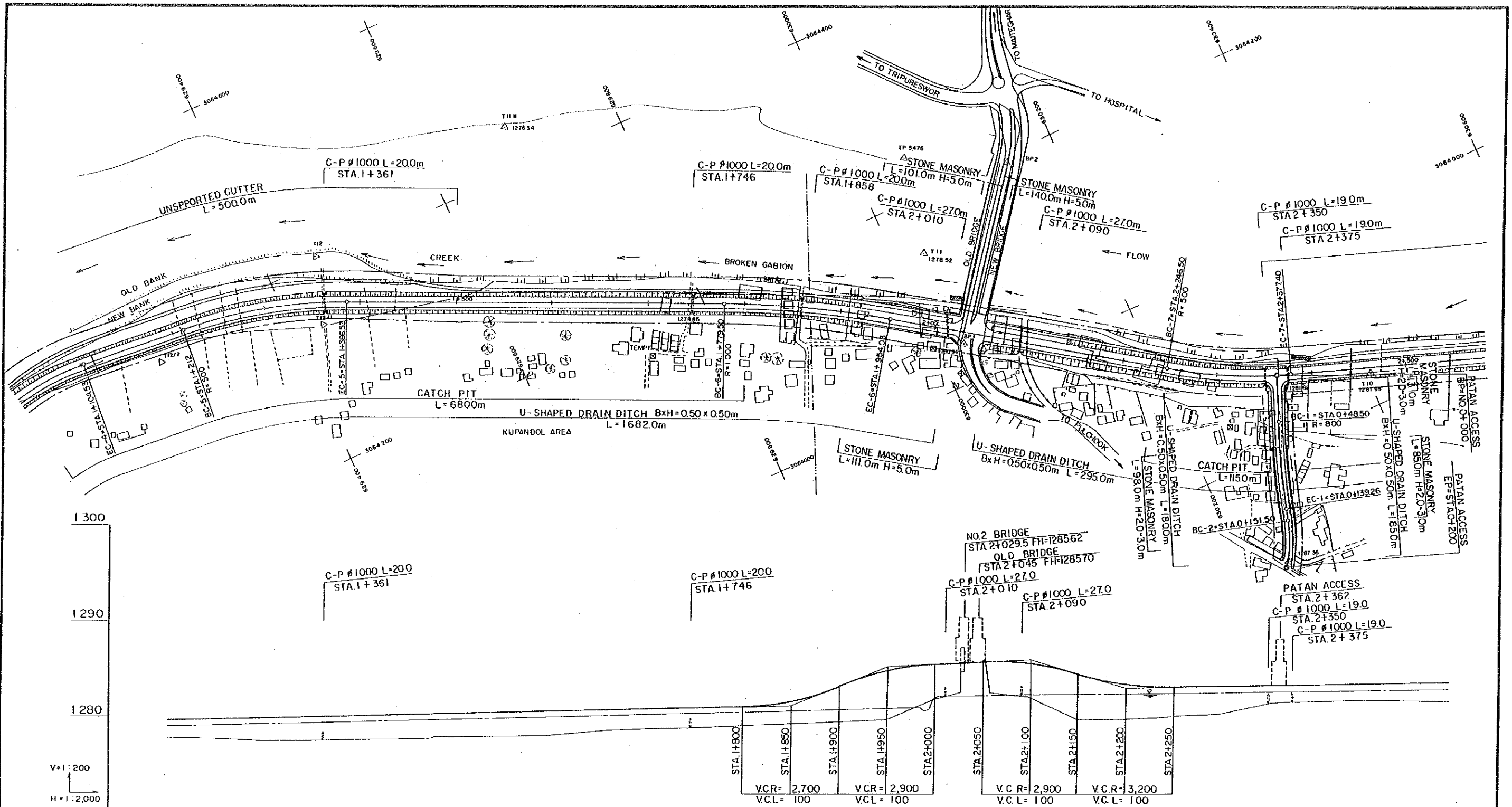

GRADIENT	$I = 0.250\%$ $I = 3.970\%$ $I = 0.500\%$ $I = 2.920\%$ $I = 2.500\%$																										
SUPER ELEVATION	4.000% -2.500% 2.500% -2.500% 4.000% -2.500%																										
FORMATION HEIGHT	27963	27975	27988	28000	28013	28025	28038	28050	28063	28075	28088	28100	28113	28125	28137	28149	28161	28173	28185	28197							
GROUND HEIGHT	127780	127770	127750	127750	127760	127770	127790	127800	127810	127850	127880	127885	127910	127930	127950	127970	127980	127980	128010	128040	128150	128170	128190	128180			
STATION	200	250	300	350	400	450	500	550	600	650	700	750	800	850	900	950	1000	1050	1100	1150	1200	1250	1300	1350	1400	1450	1500

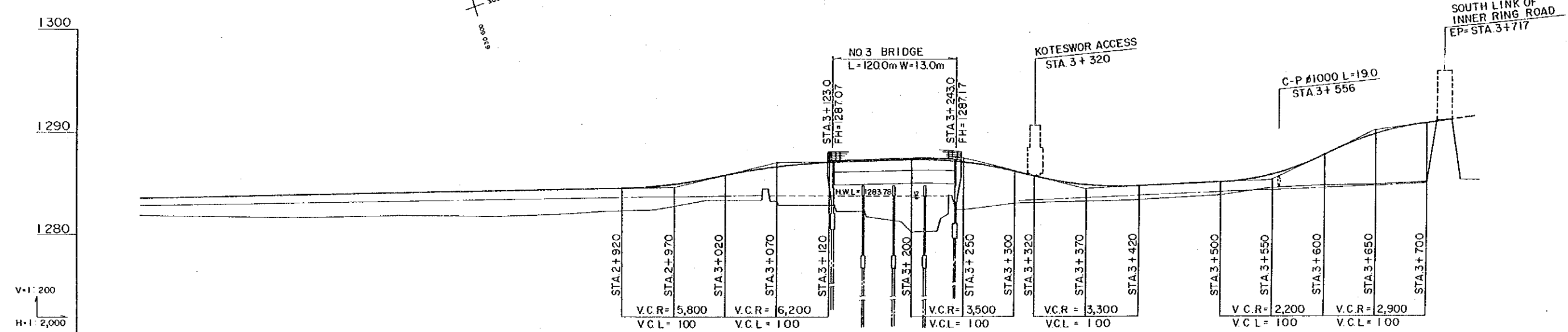
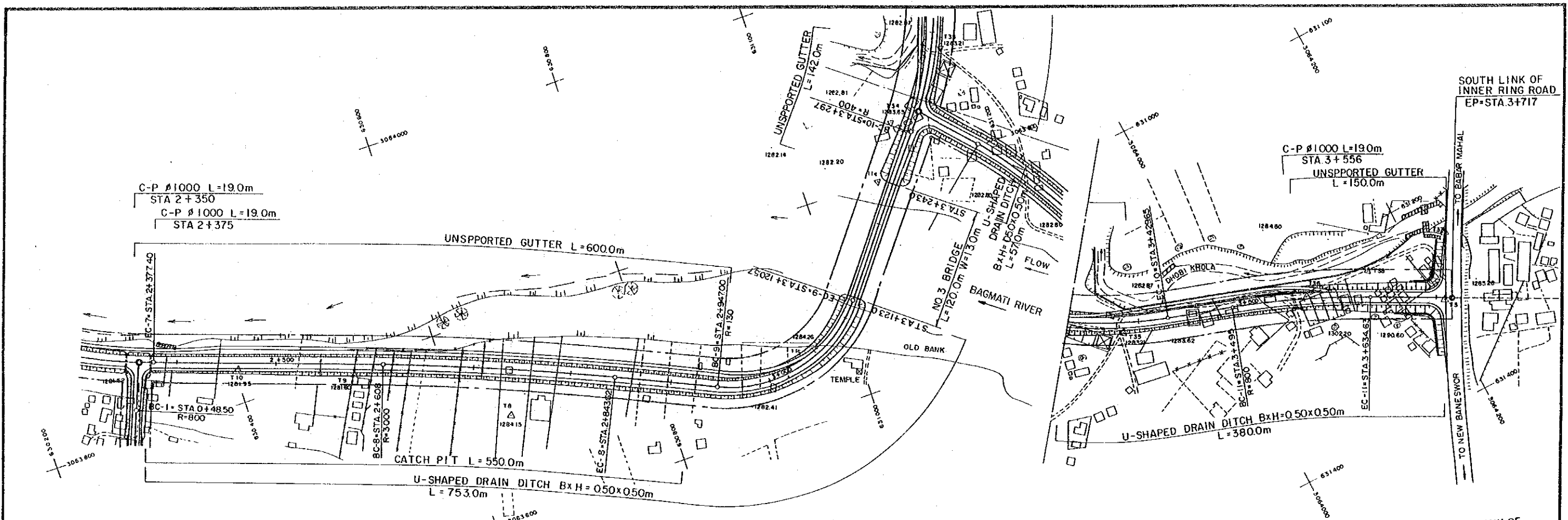

STATION	GROUND HEIGHT	FORMATION HEIGHT	SUPER ELEVATION	GRADIENT
450	1281.90	1283.55	0.0%	1=0.200%
500	1281.80	1283.65	0.0%	1=2.320%
550	1281.70	1283.75	0.0%	1=0.300%
600	1281.60	1283.85	0.0%	1=-2.500%
650	1281.70	1283.95	0.0%	1=0.500%
700	1281.80	1284.05	0.0%	1=4.650%
750	1281.80	1284.15	0.0%	1=0.000%
800	1281.70	1284.25	0.0%	1=2.500%
850	1281.90	1284.35	0.0%	1=0.500%
900	1282.20	1284.45	0.0%	1=0.500%
950	1282.40	1284.65	0.0%	1=0.500%
100	1282.80	1286.96	0.0%	1=0.500%
150	1282.15	1287.15	0.0%	1=0.500%
200	1280.10	1287.30	0.0%	1=0.500%
250	1282.30	1287.10	0.0%	1=0.500%
300	1283.00	1286.20	0.0%	1=0.500%
350	1283.10	1285.09	0.0%	1=0.500%
400	1283.20	1284.65	0.0%	1=0.500%
450	1283.50	1284.45	0.0%	1=0.500%
500	1283.80	1285.10	0.0%	1=0.500%
550	1284.50	1285.87	0.0%	1=0.500%
600	1284.70	1287.68	0.0%	1=0.500%
650	1284.80	1289.62	0.0%	1=0.500%
700	1285.00	1290.76	0.0%	1=0.500%
717	1291.00	1291.00	0.0%	1=0.500%

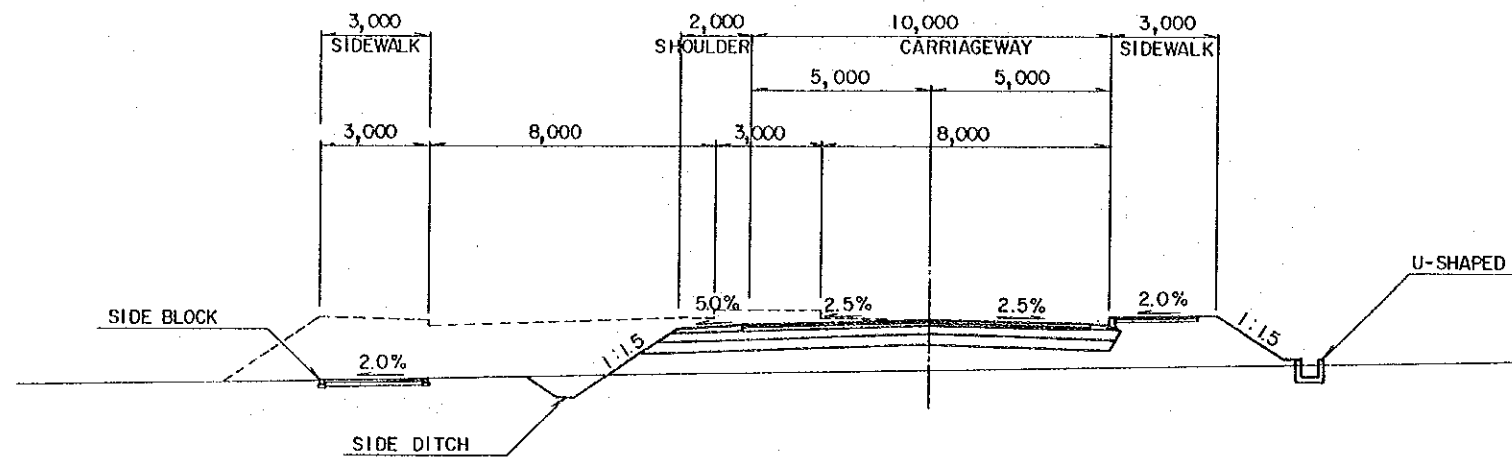

TYPICAL CROSS-SECTION OF SOUTH LINK OF INNER RING ROAD TYPE A SCALE 1 : 100
(TO BE ADOPTED IN OPEN AREA)

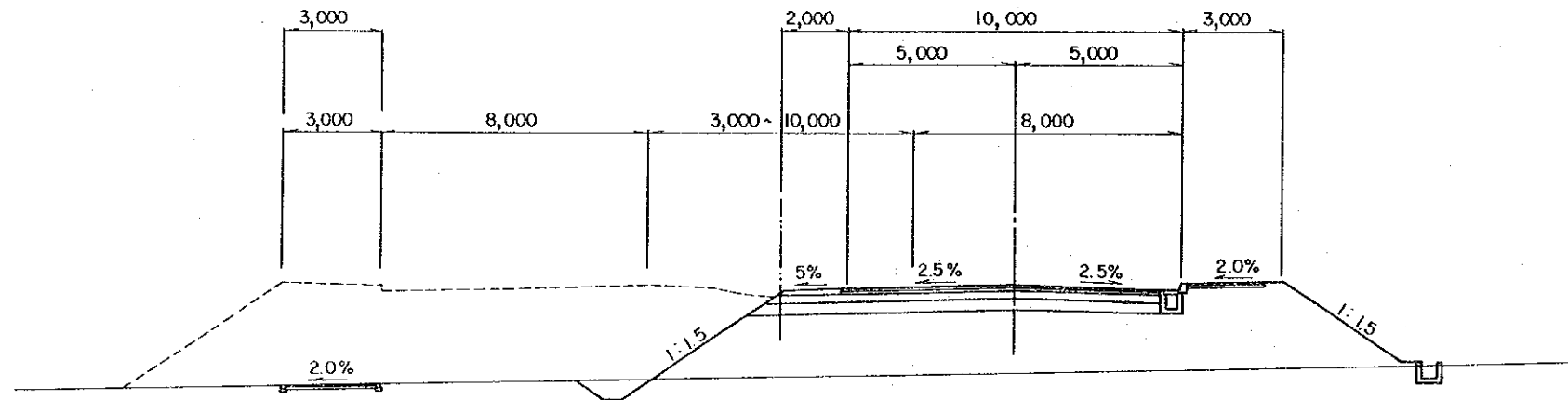

TYPICAL CROSS-SECTION OF SOUTH LINK OF INNER RING ROAD TYPE B SCALE 1 : 100
(TO BE ADOPTED IN OPEN AREA BESIDE THE RIVER)

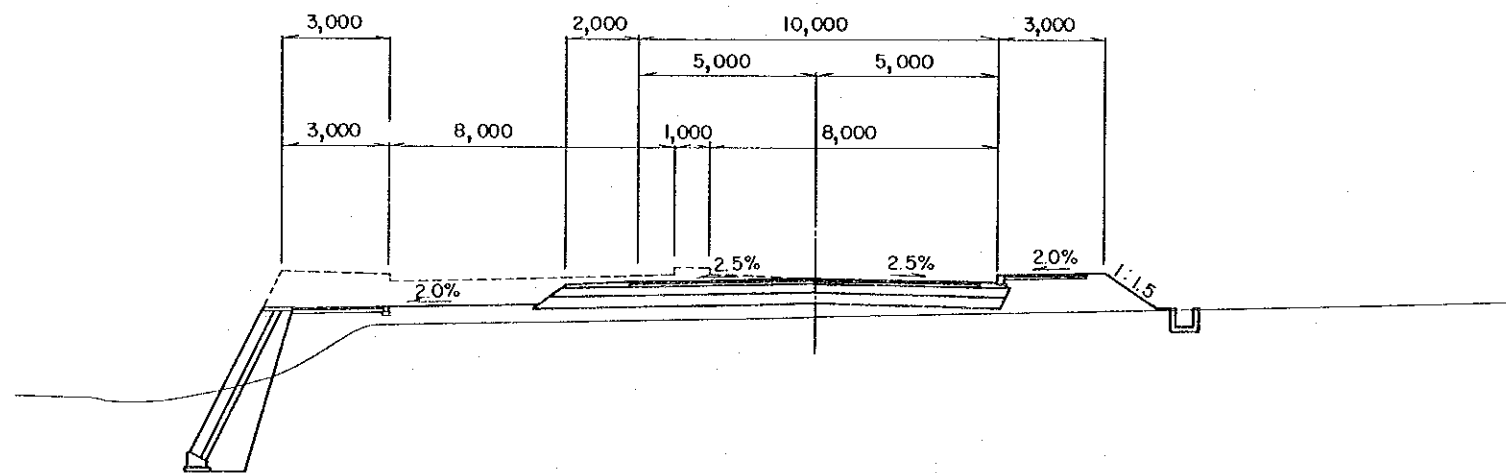

TYPICAL CROSS-SECTION OF SOUTH LINK OF INNER RING ROAD TYPE C SCALE 1 : 100
(TO BE ADOPTED IN BUILD UP AREA)

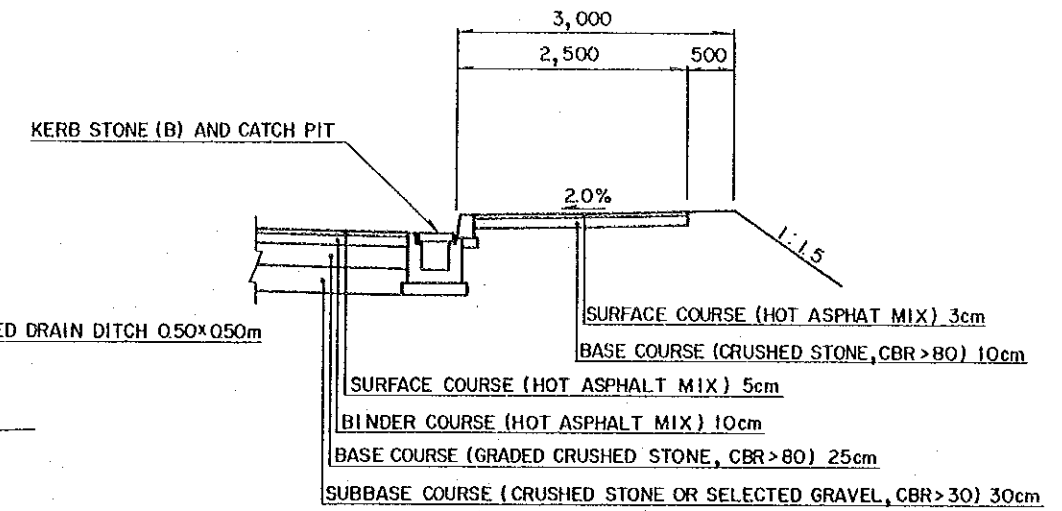

TYPICAL PAVEMENT AND SIDEWALK DETAIL SCALE 1 : 20
(KERB STONE (B) AND CATCH PIT)

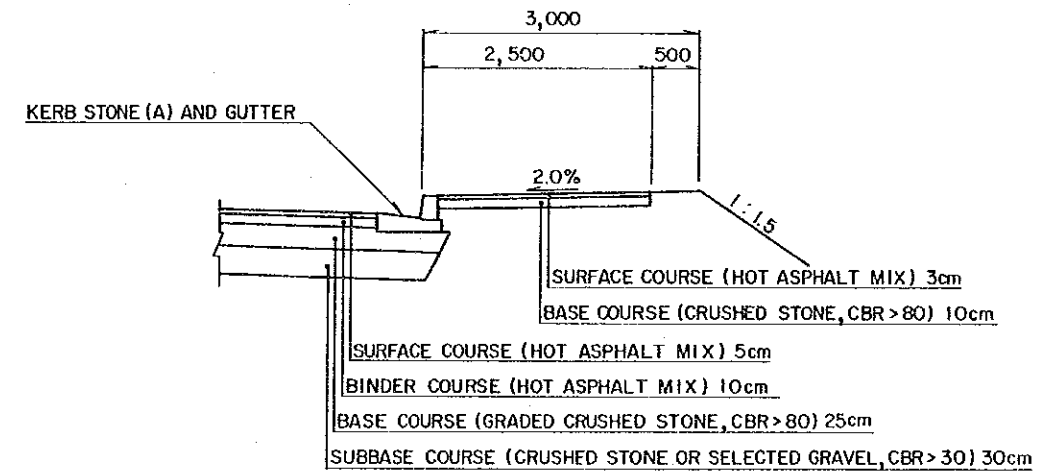

TYPICAL PAVEMENT AND SIDEWALK DETAIL SCALE 1 : 20
(KERB STONE (A) AND GUTTER)

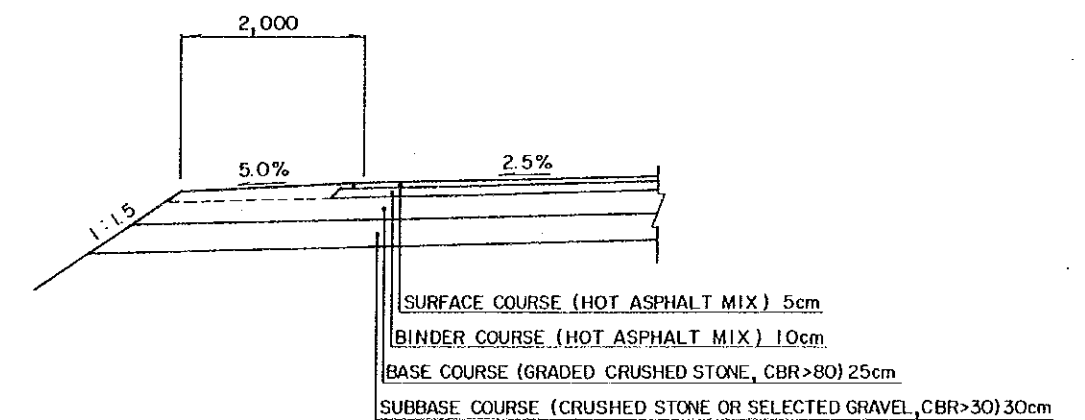

TYPICAL PAVEMENT AND SHOULDER DETAIL SCALE 1 : 20

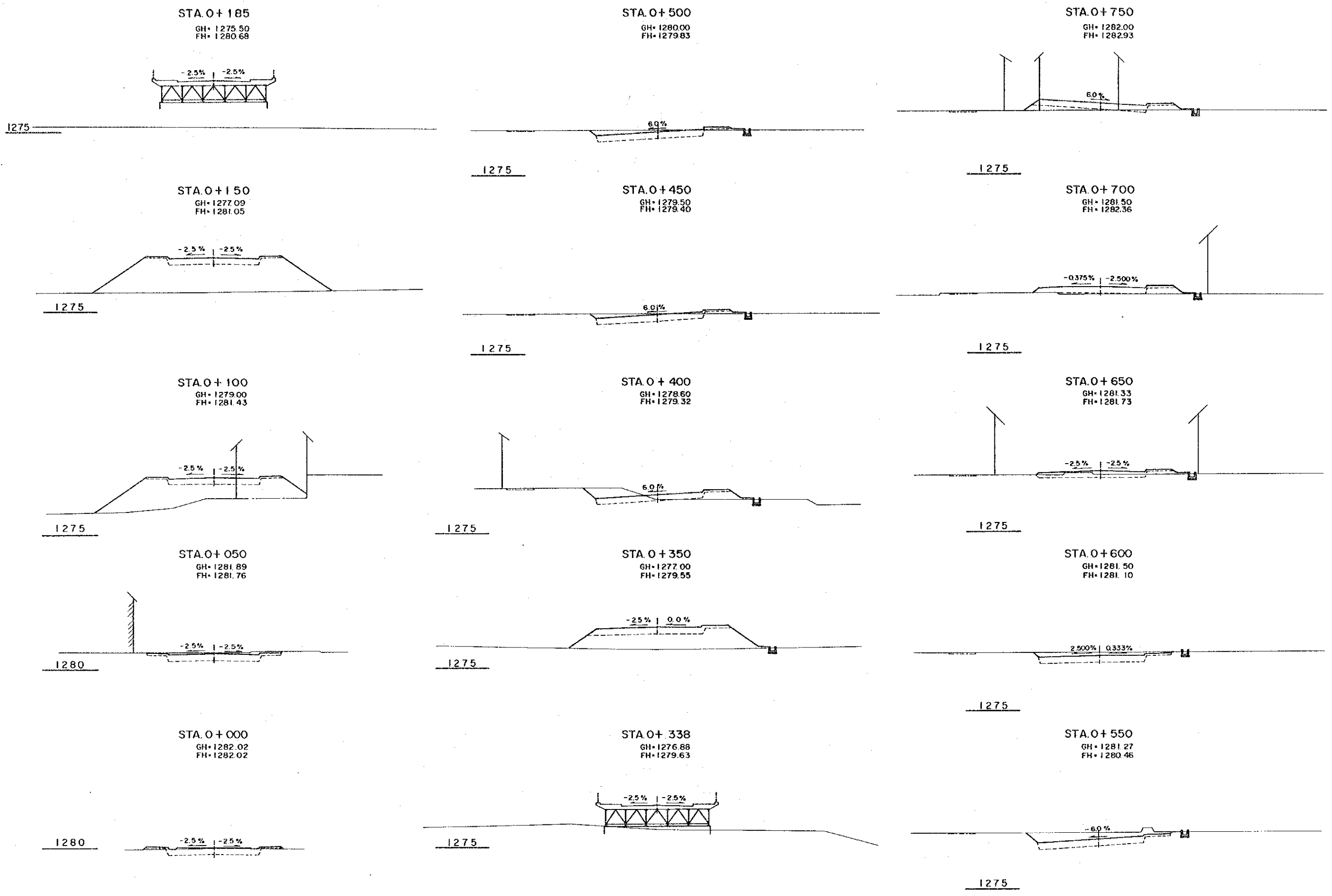

HIS MAJESTY'S GOVERNMENT OF NEPAL MINISTRY OF WORKS AND TRANSPORT DEPARTMENT OF ROADS	THE STUDY ON KATHMANDU VALLEY URBAN ROAD DEVELOPMENT	JAPAN INTERNATIONAL COOPERATION AGENCY	SOUTH LINK OF INNER RING ROAD	DATE	SHEET NO.
			CROSS SECTION (1)	MARCH 1993	10 40

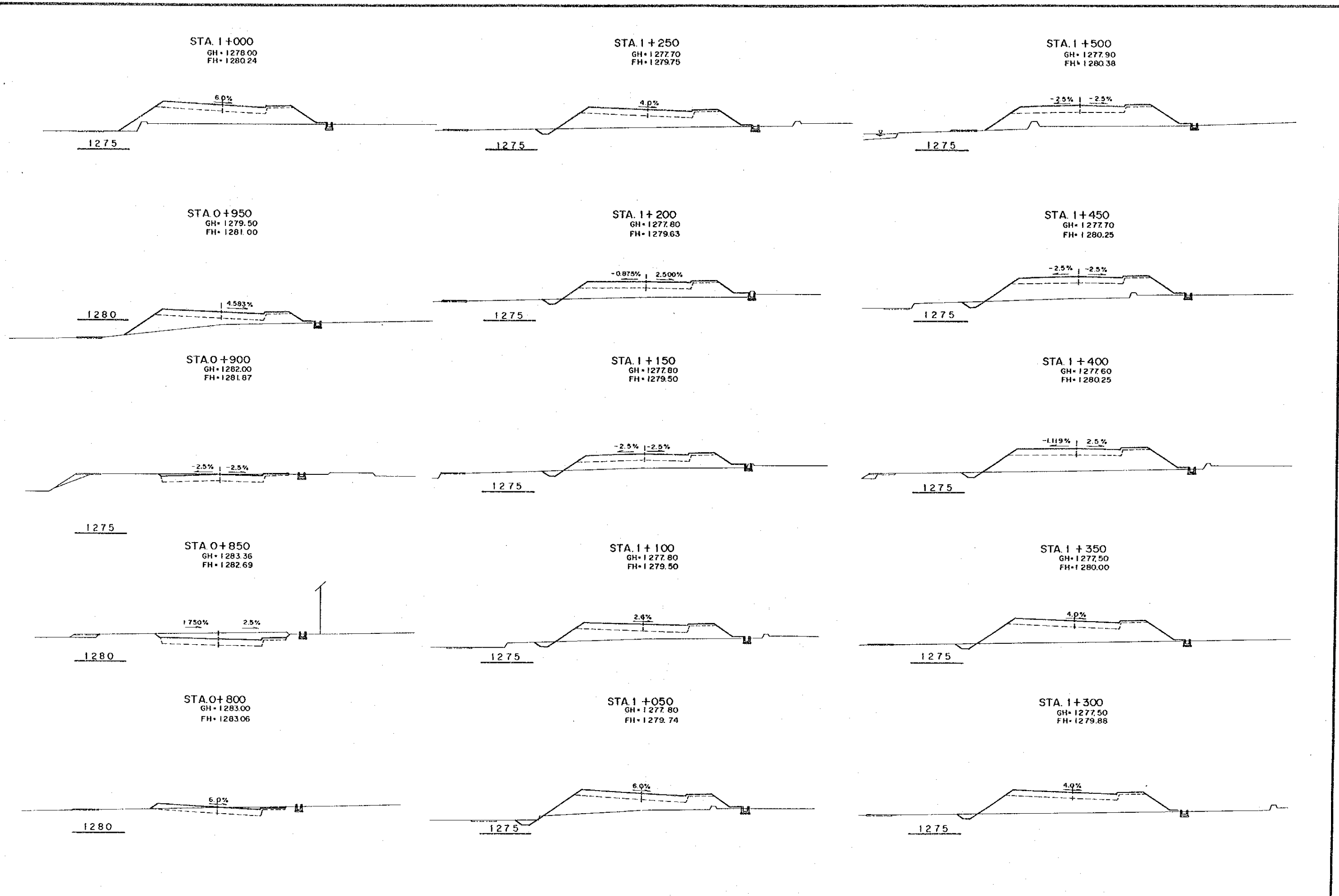

HIS MAJESTY'S GOVERNMENT OF NEPAL MINISTRY OF WORKS AND TRANSPORT DEPARTMENT OF ROADS	THE STUDY ON KATHMANDU VALLEY URBAN ROAD DEVELOPMENT	JAPAN INTERNATIONAL COOPERATION AGENCY	SOUTH LINK OF INNER RING ROAD	DATE	SHEET NO.
			CROSS SECTION (2)	MARCH 1993	11 40

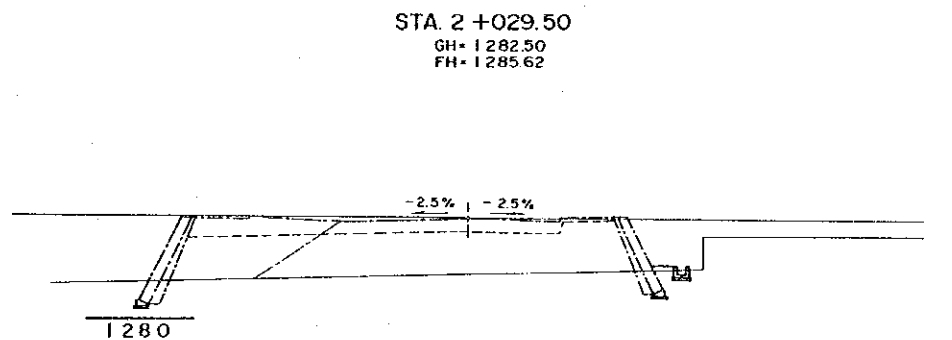
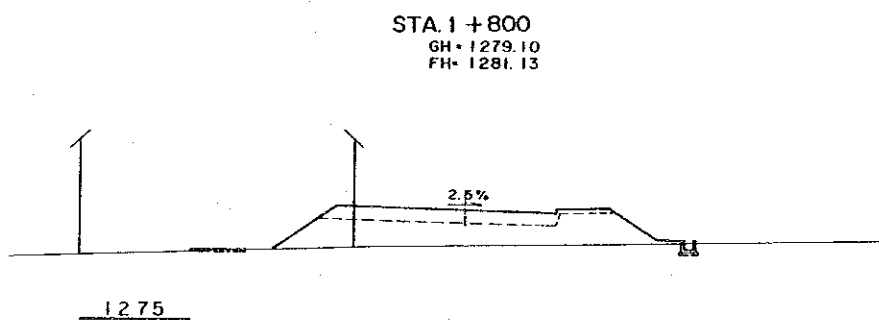
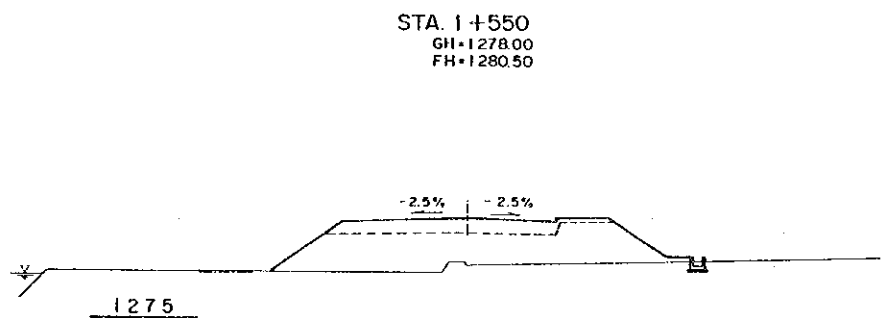
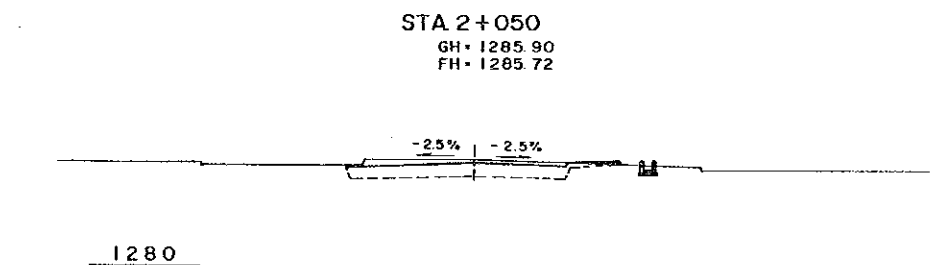
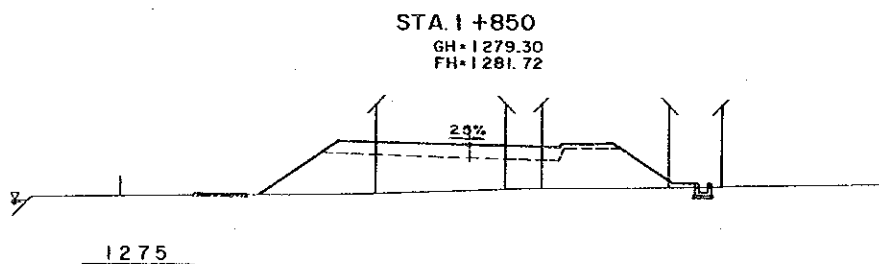
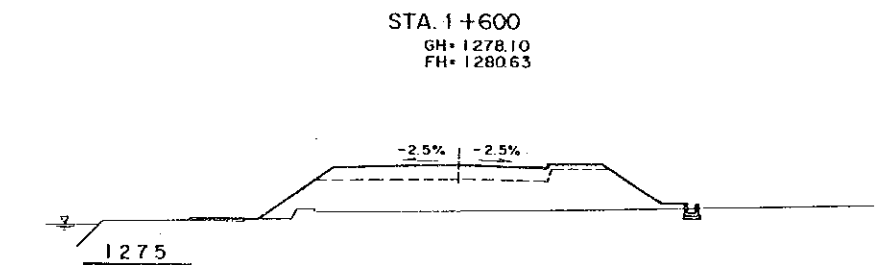
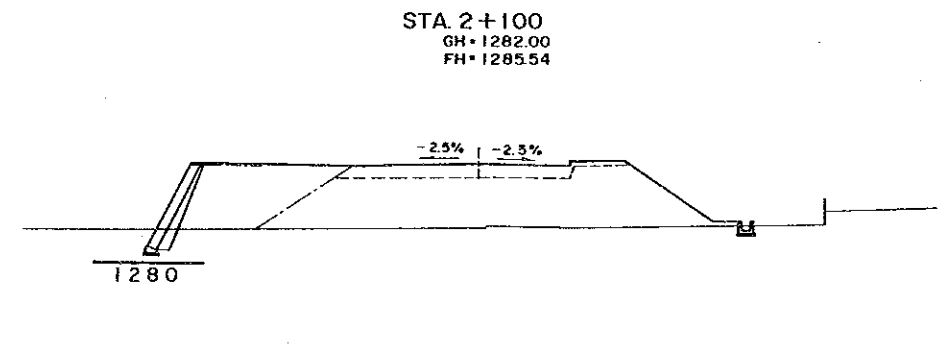
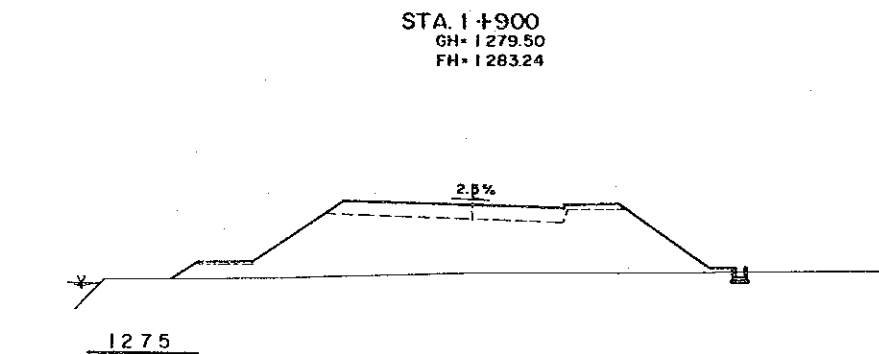
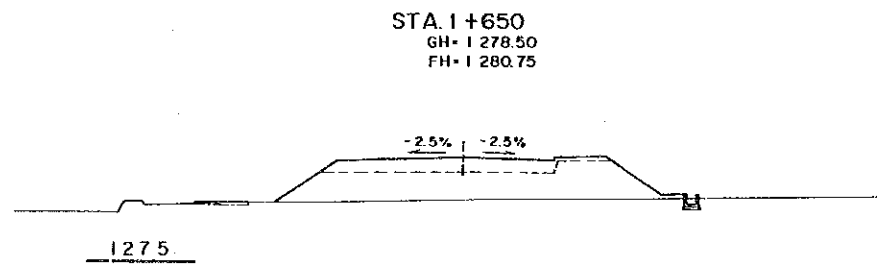
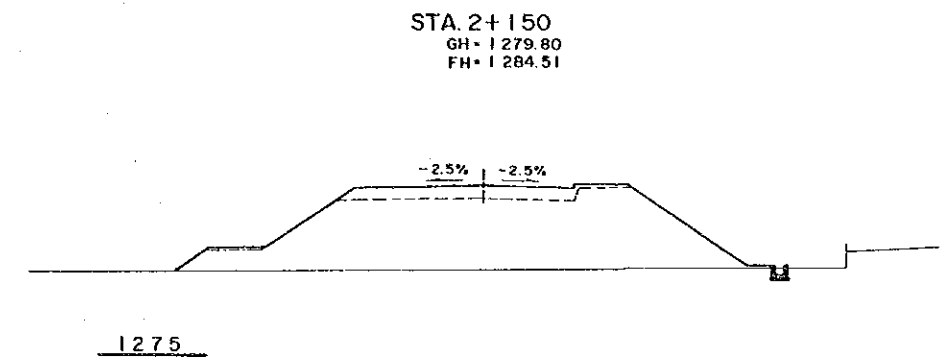
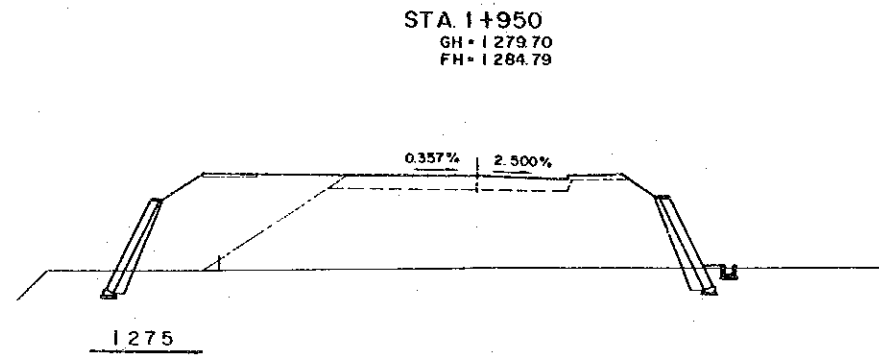
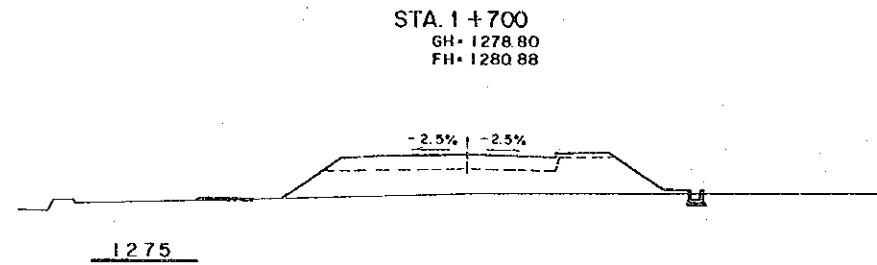
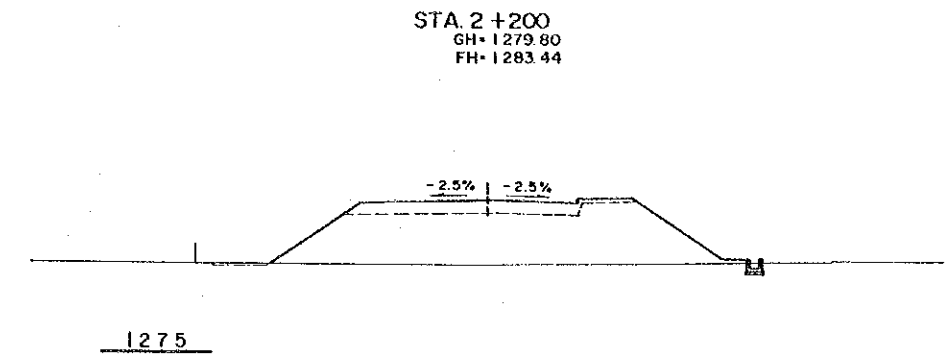
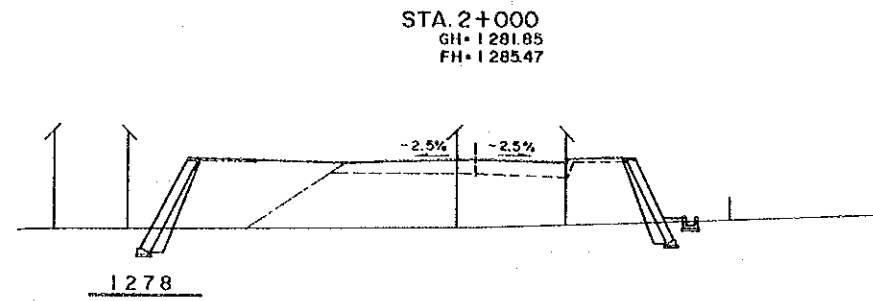
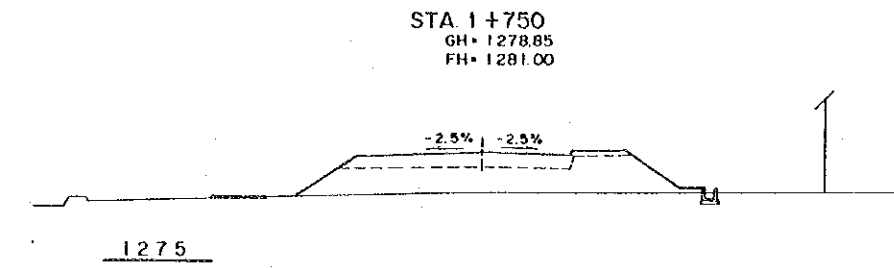

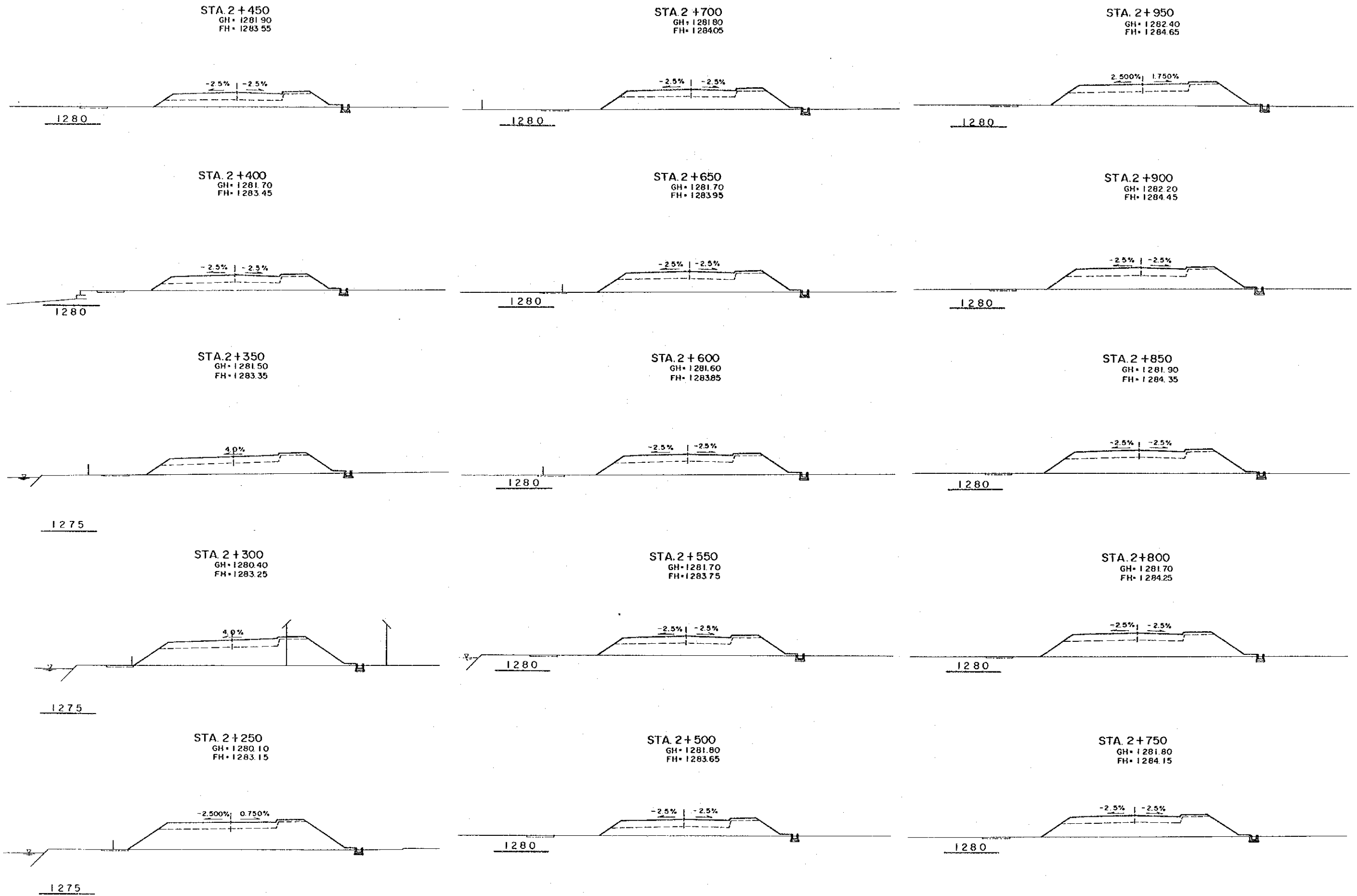

HIS MAJESTY'S GOVERNMENT OF NEPAL MINISTRY OF WORKS AND TRANSPORT DEPARTMENT OF ROADS	THE STUDY ON KATHMANDU VALLEY URBAN ROAD DEVELOPMENT	JAPAN INTERNATIONAL COOPERATION AGENCY	SOUTH LINK OF INNER RING ROAD	DATE	SHEET NO.
			CROSS SECTION (4)	MARCH 1993	13 / 40

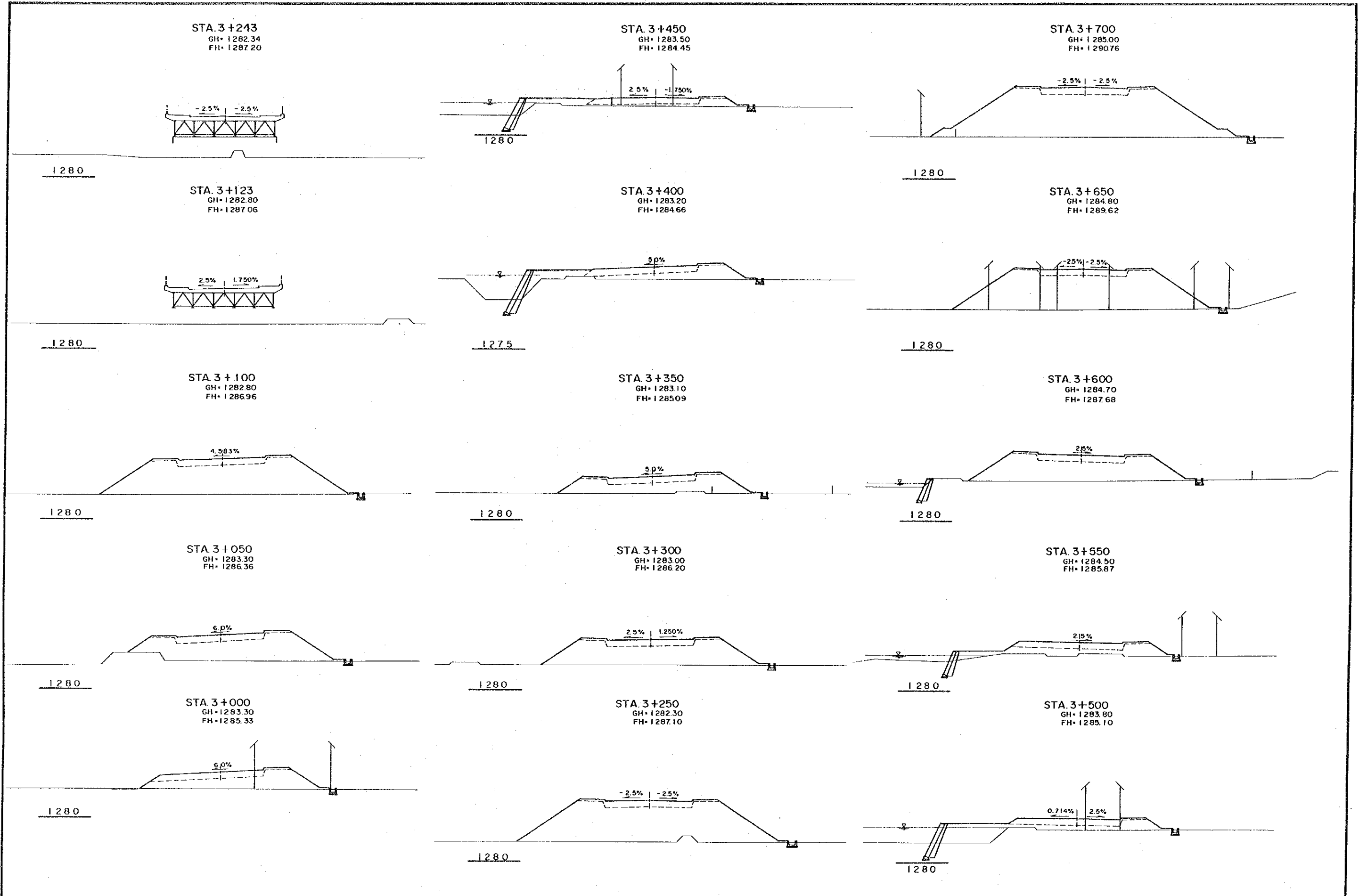

HIS MAJESTY'S GOVERNMENT OF NEPAL MINISTRY OF WORKS AND TRANSPORT DEPARTMENT OF ROADS	THE STUDY ON KATHMANDU VALLEY URBAN ROAD DEVELOPMENT	JAPAN INTERNATIONAL COOPERATION AGENCY	SOUTH LINK OF INNER RING ROAD	DATE	SHEET NO.
			CROSS SECTION (5)	MARCH 1993	14 40

BAGMATI BRIGE No.1

GENERAL ELEVATION

S = 1 : 500

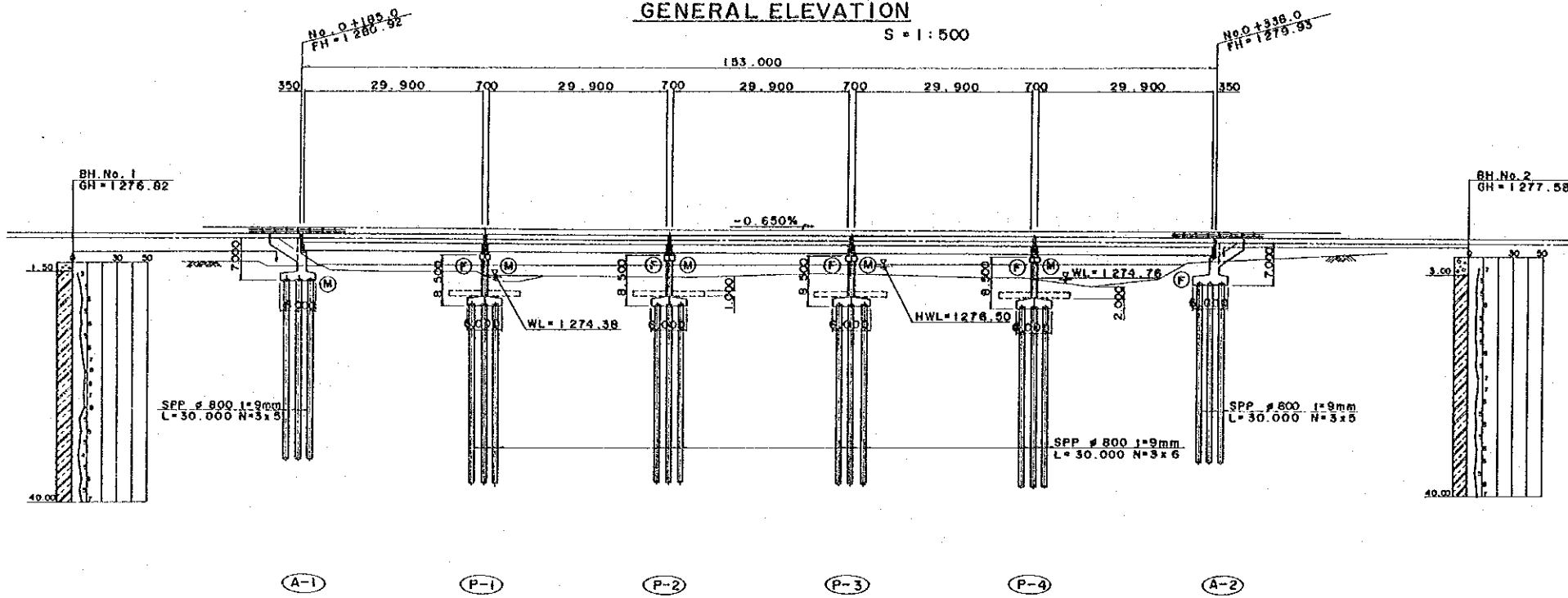

CROSS SECTION

S = 1 : 100

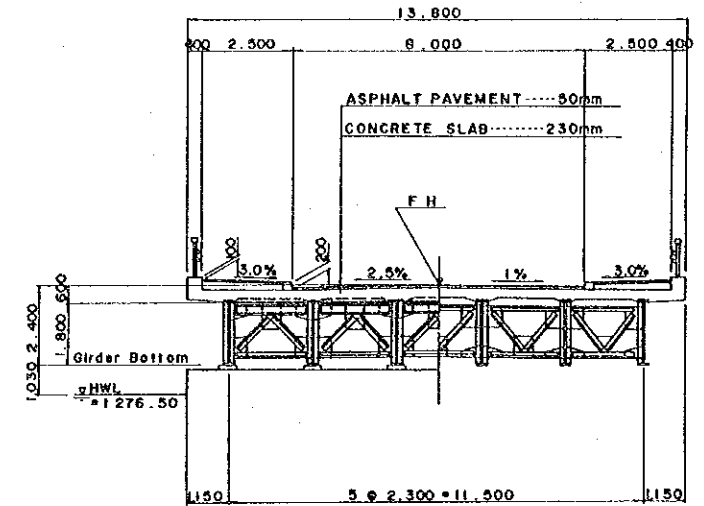

DL = 1.210 1.20 200 2.30 No. 0+300 3.50

GENERAL PLAN

S = 1 : 500

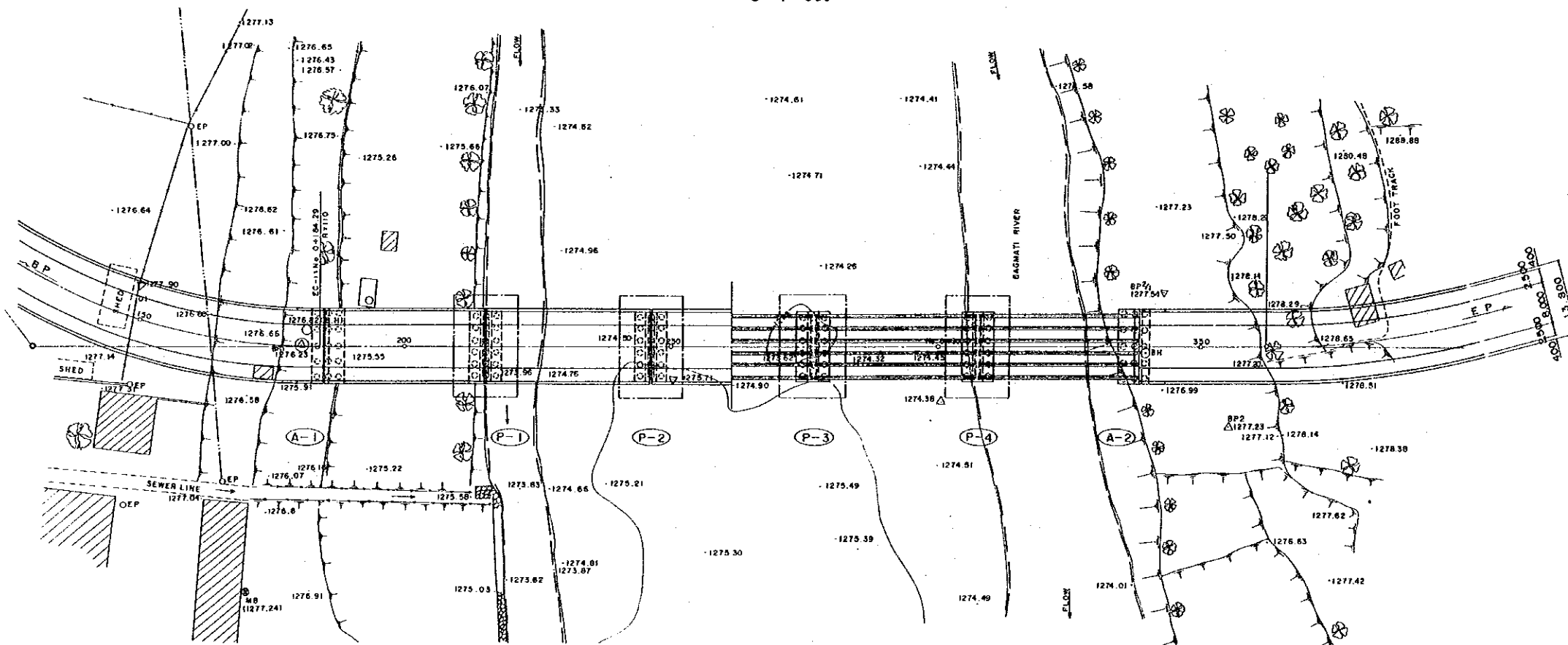

BAGMATI BRIDGE No.3

GENERAL ELEVATION

S = 1 : 500

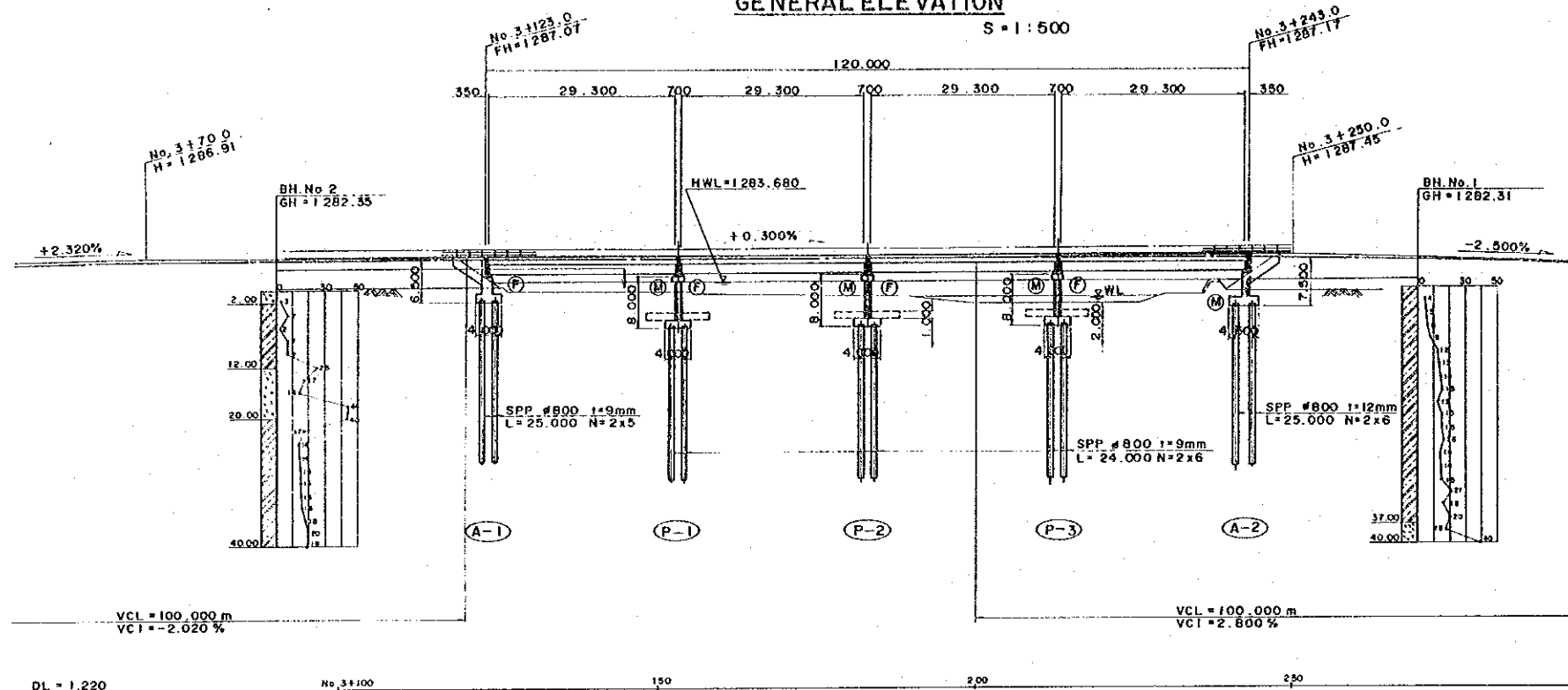

CROSS SECTION

S = 1 : 100

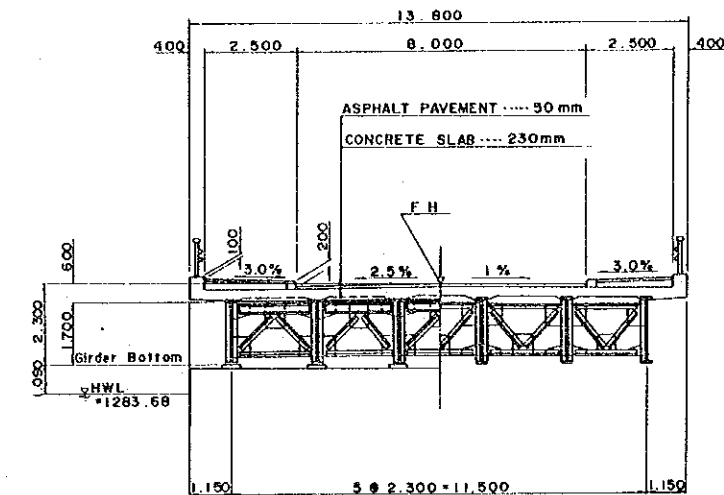

GENERAL PLAN

S = 1 : 500

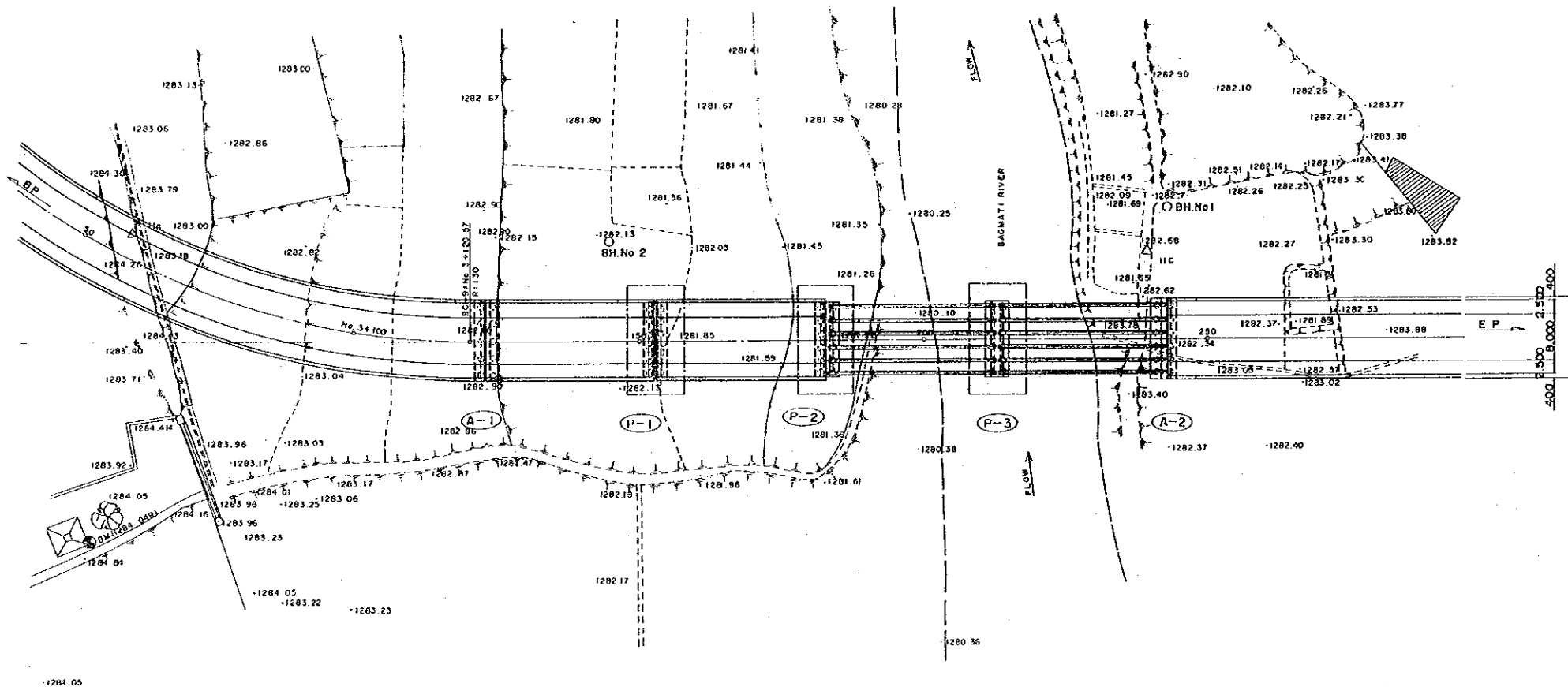

HIS MAJESTY'S GOVERNMENT OF NEPAL
MINISTRY OF WORKS AND TRANSPORT
DEPARTMENT OF ROADS

THE STUDY
ON
KATHMANDU VALLEY URBAN ROAD DEVELOPMENT

JAPAN INTERNATIONAL
COOPERATION AGENCY

SOUTH LINK OF INNER RING ROAD
No.3 BRIDGE

DATE	SHEET NO.
	16 / 40

PEDESTRIAN BRIDGE No.1

GENERAL ELEVATION

S = 1 : 300

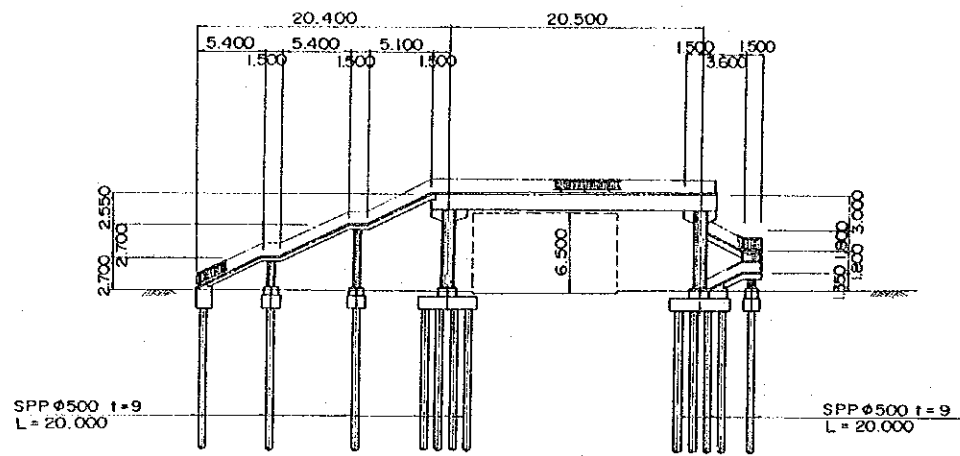

CROSS SECTION

S = 1 : 50, 1 : 40

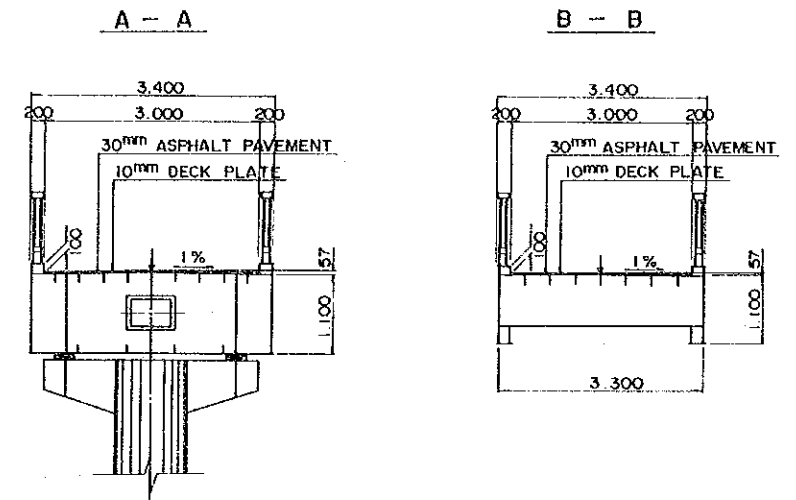

GENERAL PLAN

S = 1 : 300

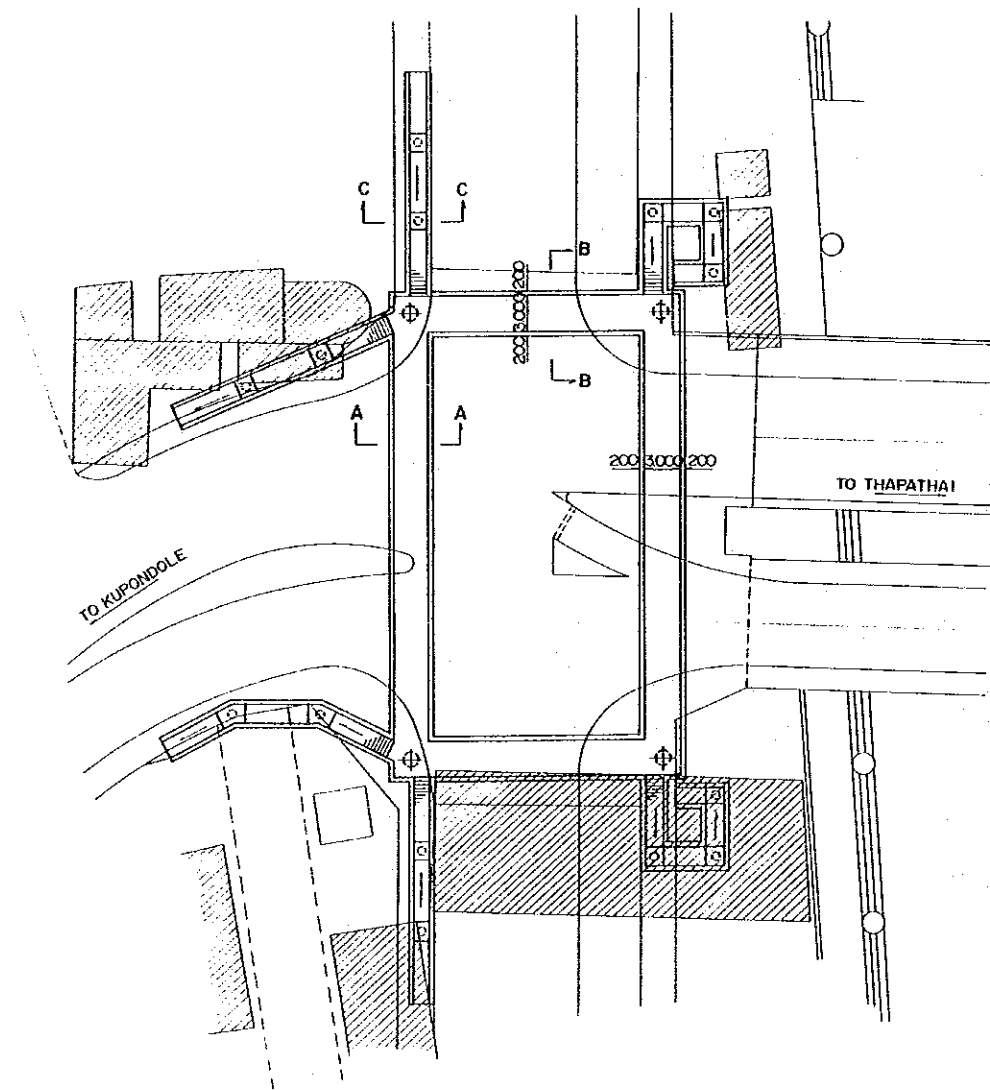

C - C

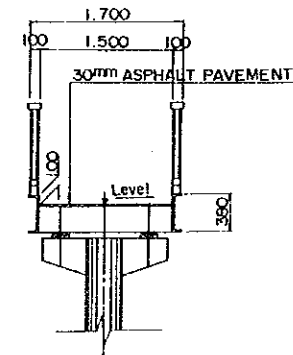

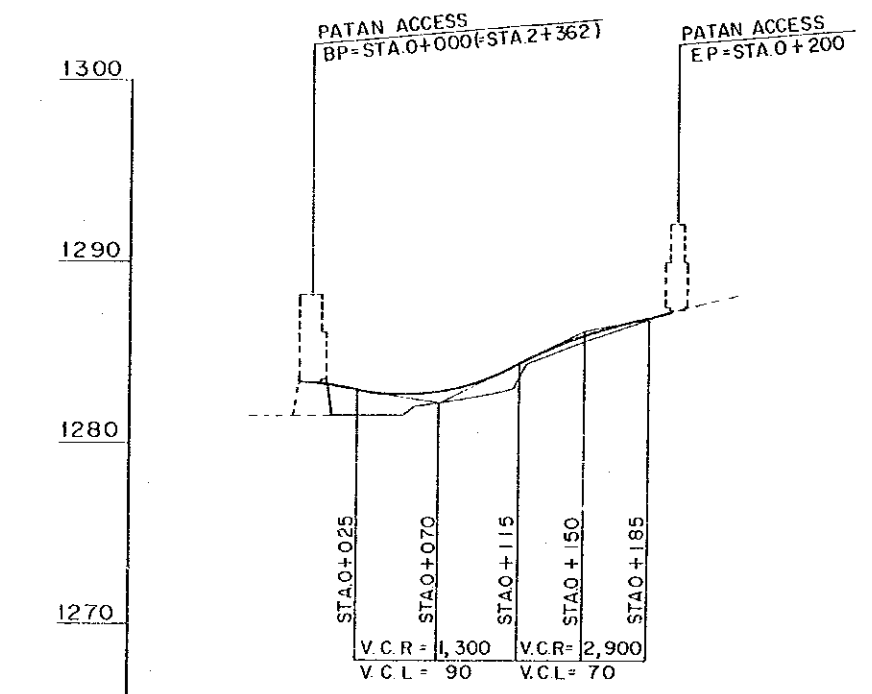
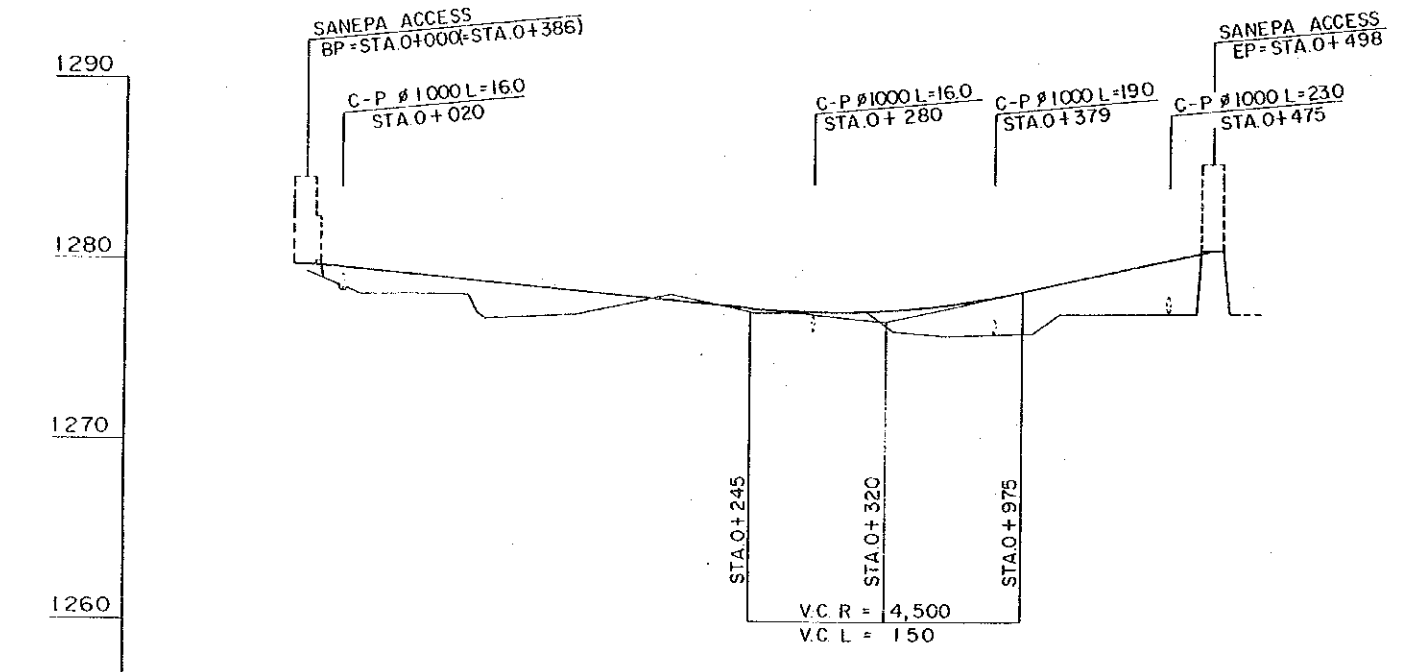
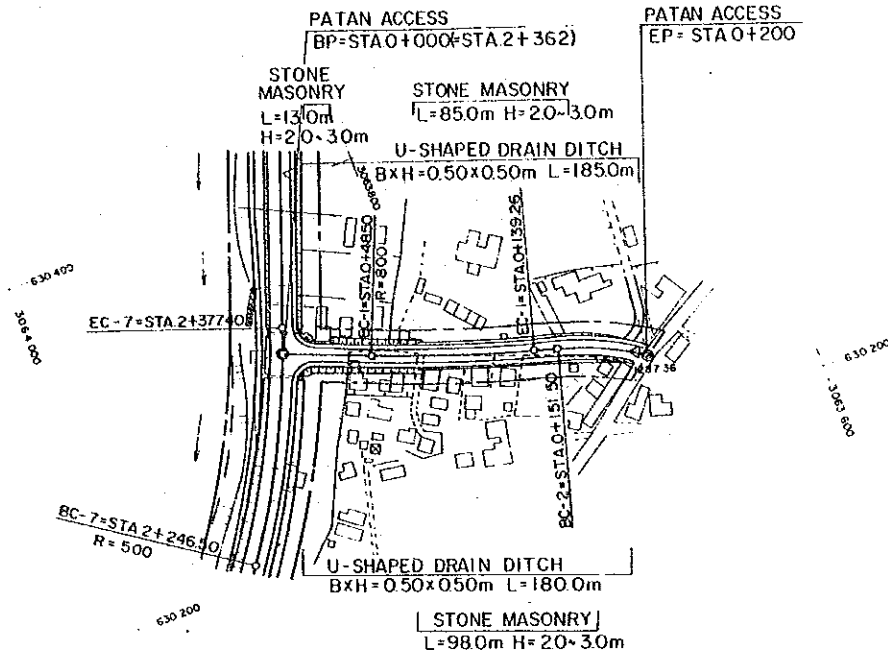
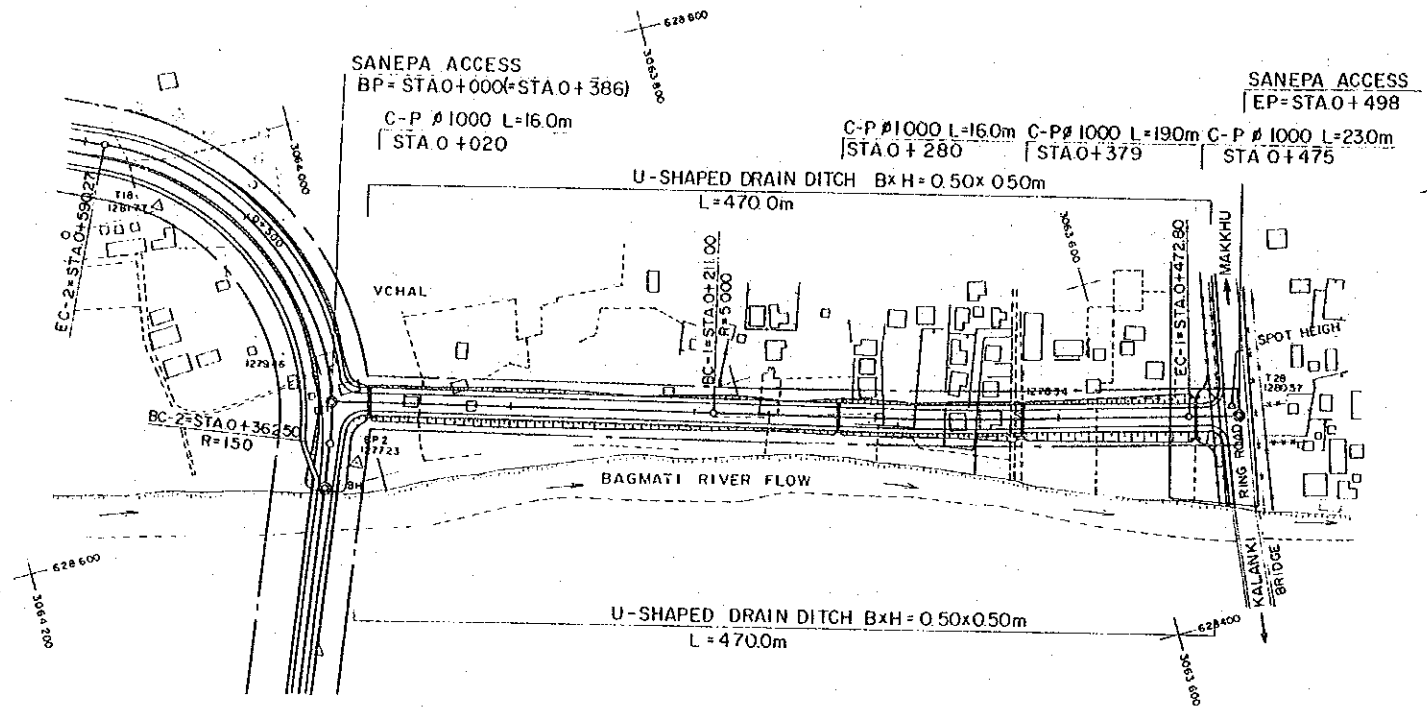

GRADIENT	-1.000% (1276.48) 2.300%										
SUPER ELEVATION	-2.500%										
FORMATION HEIGHT	100+000	50	100	150	200	250	300	350	400	450	498
GROUND HEIGHT	1279.30	1279.18	1278.68	1278.18	1277.68	1277.18	1277.10	1277.24	1278.32	1279.47	1280.57
STATION	100+000	50	100	150	200	250	300	350	400	450	498

GRADIENT	-1.750% (1282.15) -4.950% (1286.11) -2.500%				
SUPER ELEVATION	-2.500%				
FORMATION HEIGHT	100+000	50	100	150	200
GROUND HEIGHT	1283.37	1281.59	1282.73	1283.72	1285.90
STATION	100+000	50	100	150	200

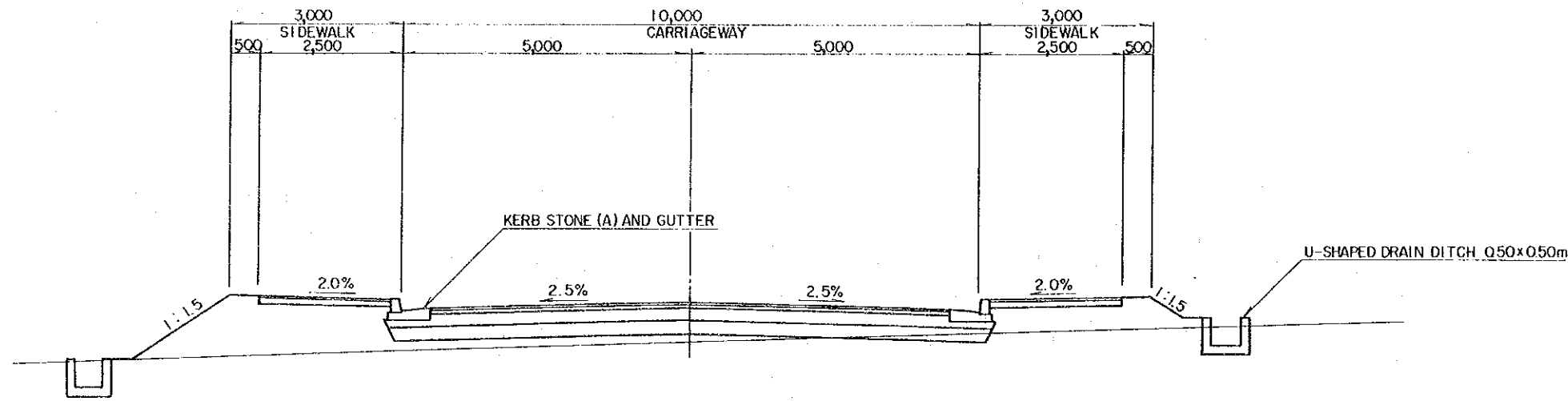

TYPICAL CROSS-SECTION OF SANEPA ACCESS SCALE 1:50

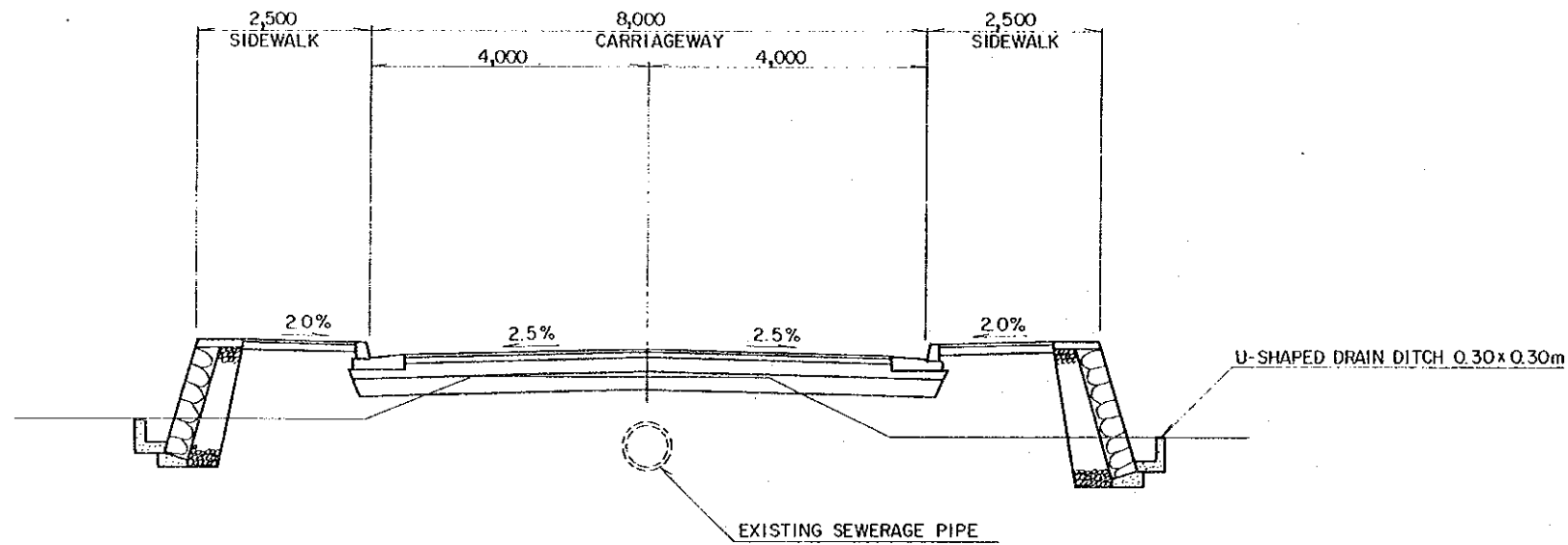
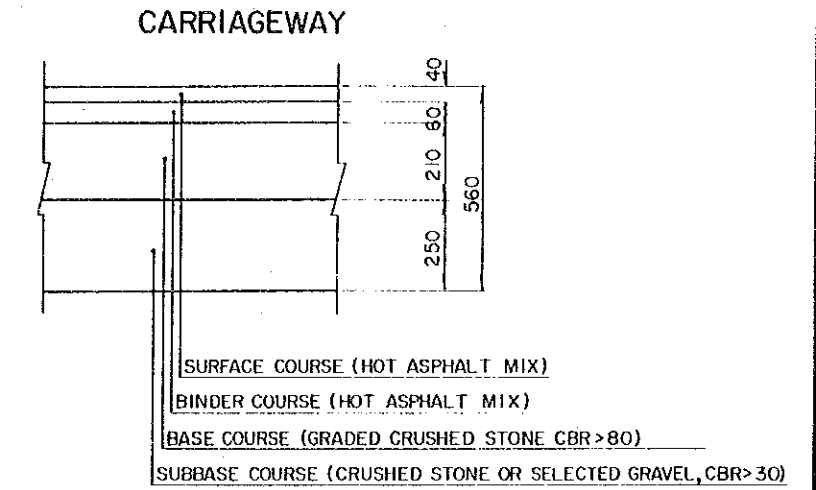

TYPICAL CROSS-SECTION OF PATAN ACCESS SCALE 1:50

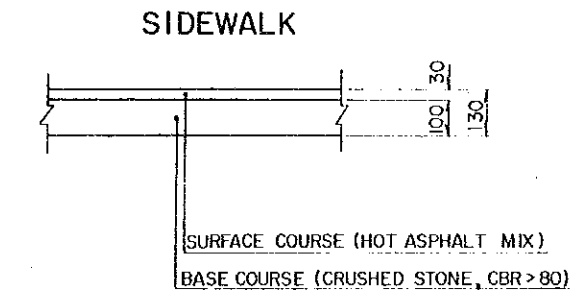

PAVEMENT STRUCTURES SCALE 1:10

STA.0+150
GH=1276.95
FH=1278.18

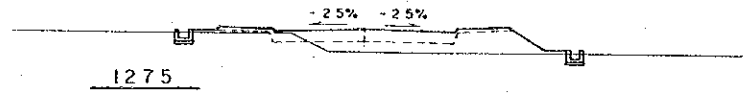

STA.0+350
GH=1275.80
FH=1277.24

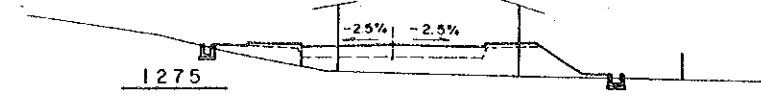

STA.0+100
GH=1276.70
FH=1278.68

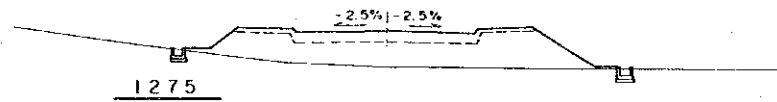

STA.0+300
GH=1277.10
FH=1277.01

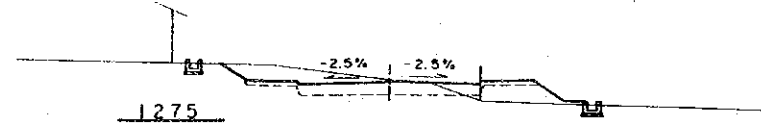

STA.0+498
GH=1277.05
FH=1280.57

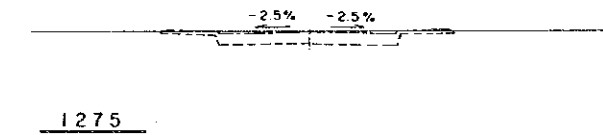

STA.0+050
GH=1278.13
FH=1279.18

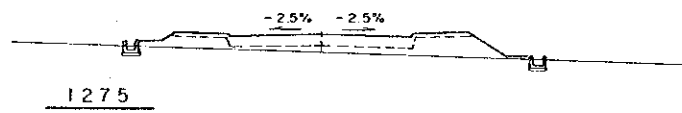

STA.0+250
GH=1277.05
FH=1277.18

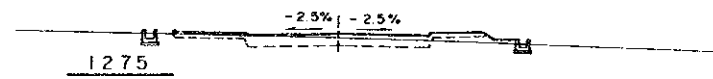

STA.0+450
GH=1276.95
FH=1279.47

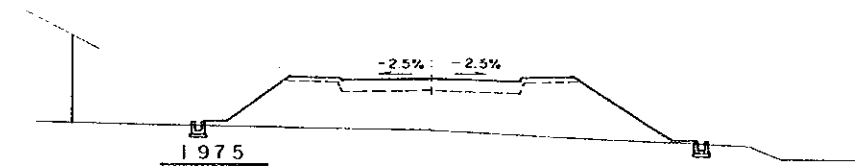

STA.0+000
GH=1279.30
FH=1279.68

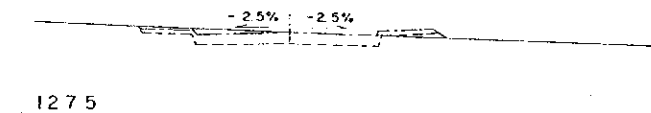

STA.0+200
GH=1278.00
FH=1277.68

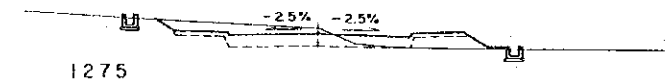

STA.0+400
GH=1975.90
FH=1978.32

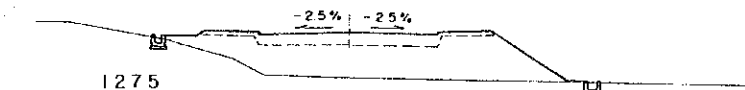

HIS MAJESTY'S GOVERNMENT OF NEPAL
MINISTRY OF WORKS AND TRANSPORT
DEPARTMENT OF ROADS

THE STUDY
ON
KATHMANDU VALLEY URBAN ROAD DEVELOPMENT

JAPAN INTERNATIONAL
COOPERATION AGENCY

SANEP A ACCESS AND PATAN ACCESS

CROSS SECTION (1)

DATE
MARCH
1993

SHEET NO.
20
40

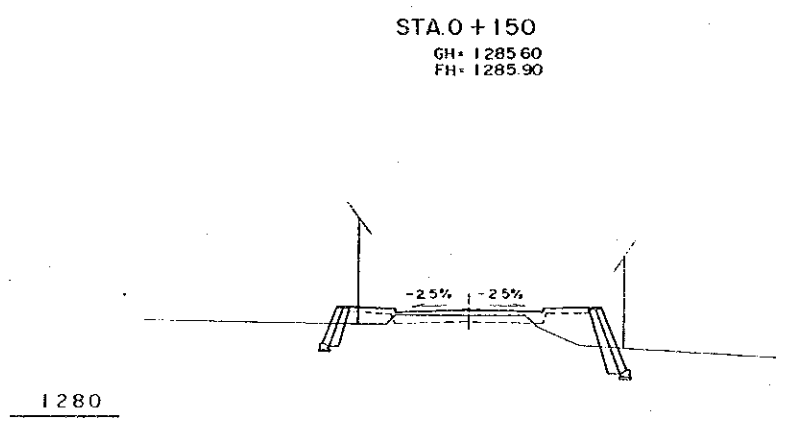
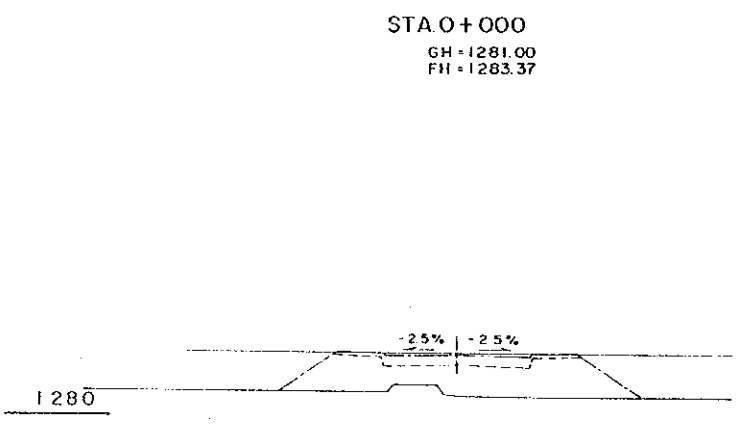
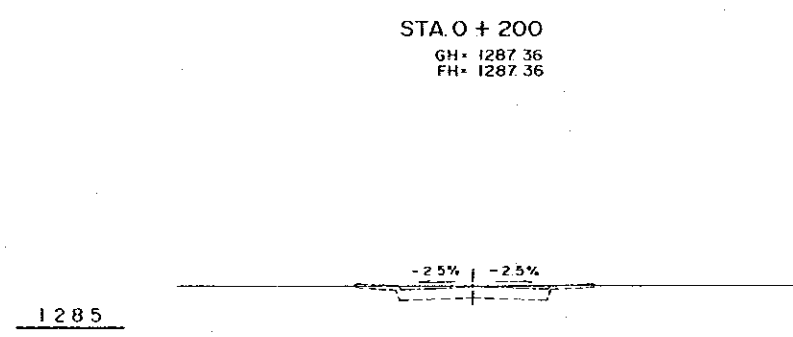
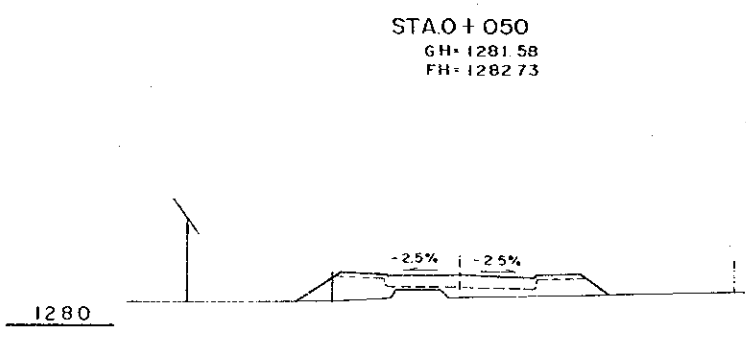
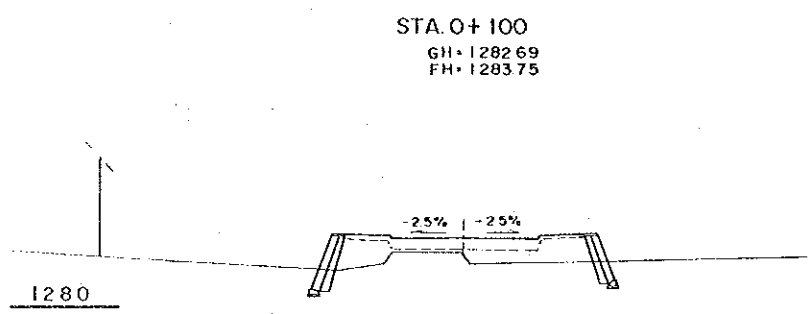

HIS MAJESTY'S GOVERNMENT OF NEPAL MINISTRY OF WORKS AND TRANSPORT DEPARTMENT OF ROADS	THE STUDY ON KATHMANDU VALLEY URBAN ROAD DEVELOPMENT	JAPAN INTERNATIONAL COOPERATION AGENCY	SANEPA ACCESS AND PATAN ACCESS	DATE	SHEET NO.
			CROSS SECTION (2)	MARCH 1993	21 40

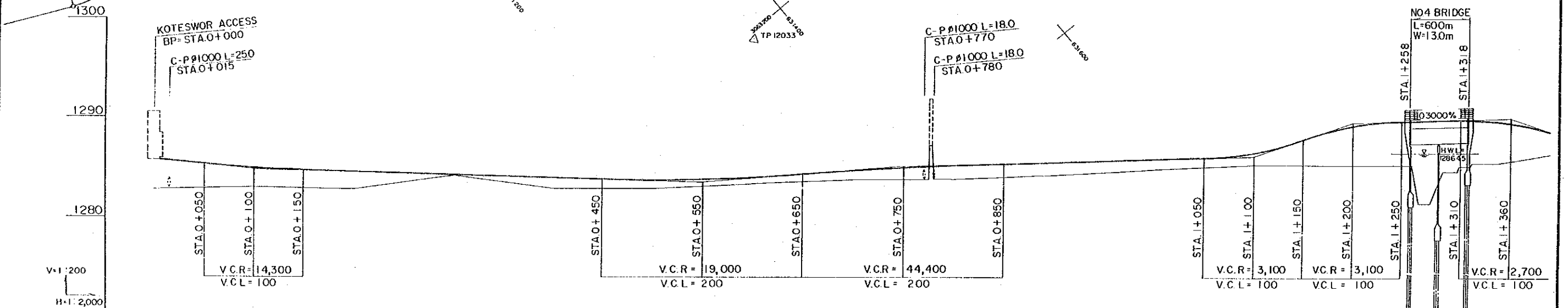
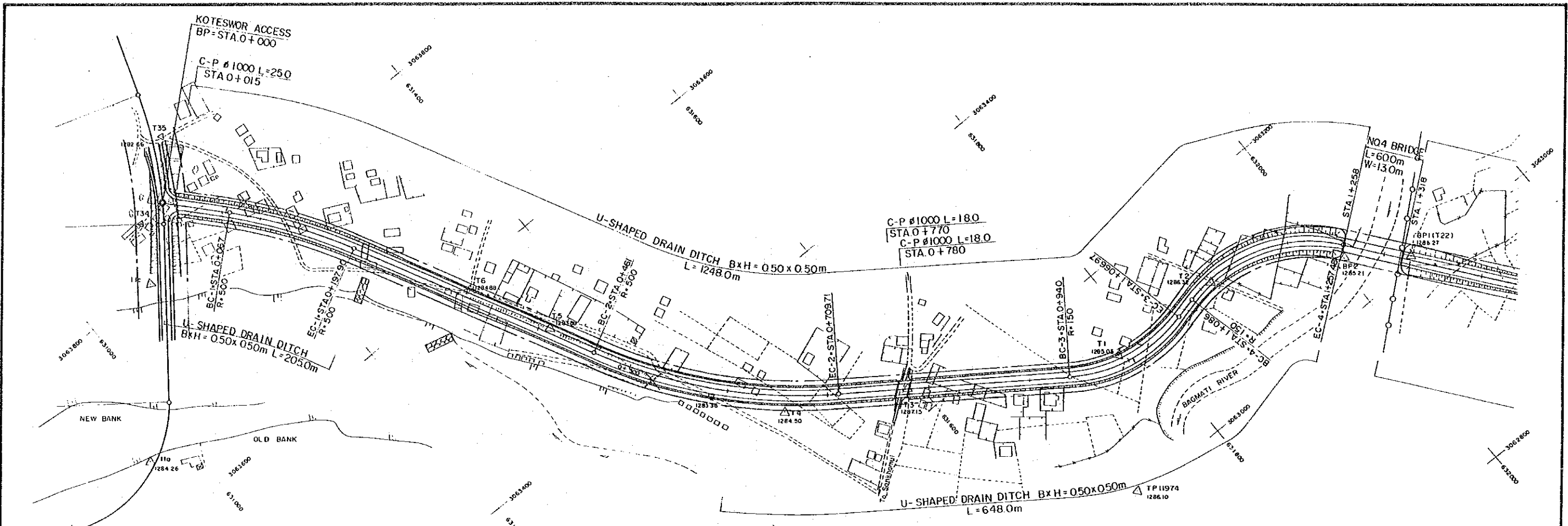

GRADIENT	-1.000%	0.300%	-0.750%	-0.300%	3.500%	0.300%
SUPER ELEVATION	4.000%	-2.500%	4.000%	-2.500%	6.000%	6.000%
FORMATION HEIGHT	1284.70	1284.79	1283.55	1284.85	1285.90	1285.40
GROUND HEIGHT	1282.80	1282.90	1282.80	1284.10	1283.50	1284.25
STATION	0+000	0+050	0+100	0+150	0+200	0+250

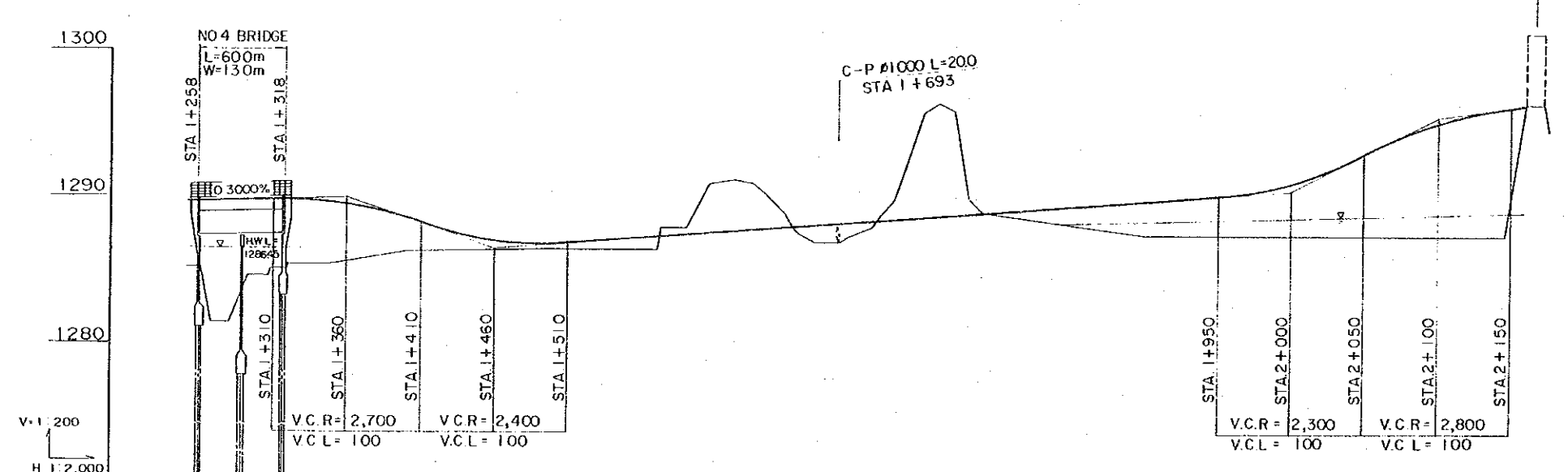
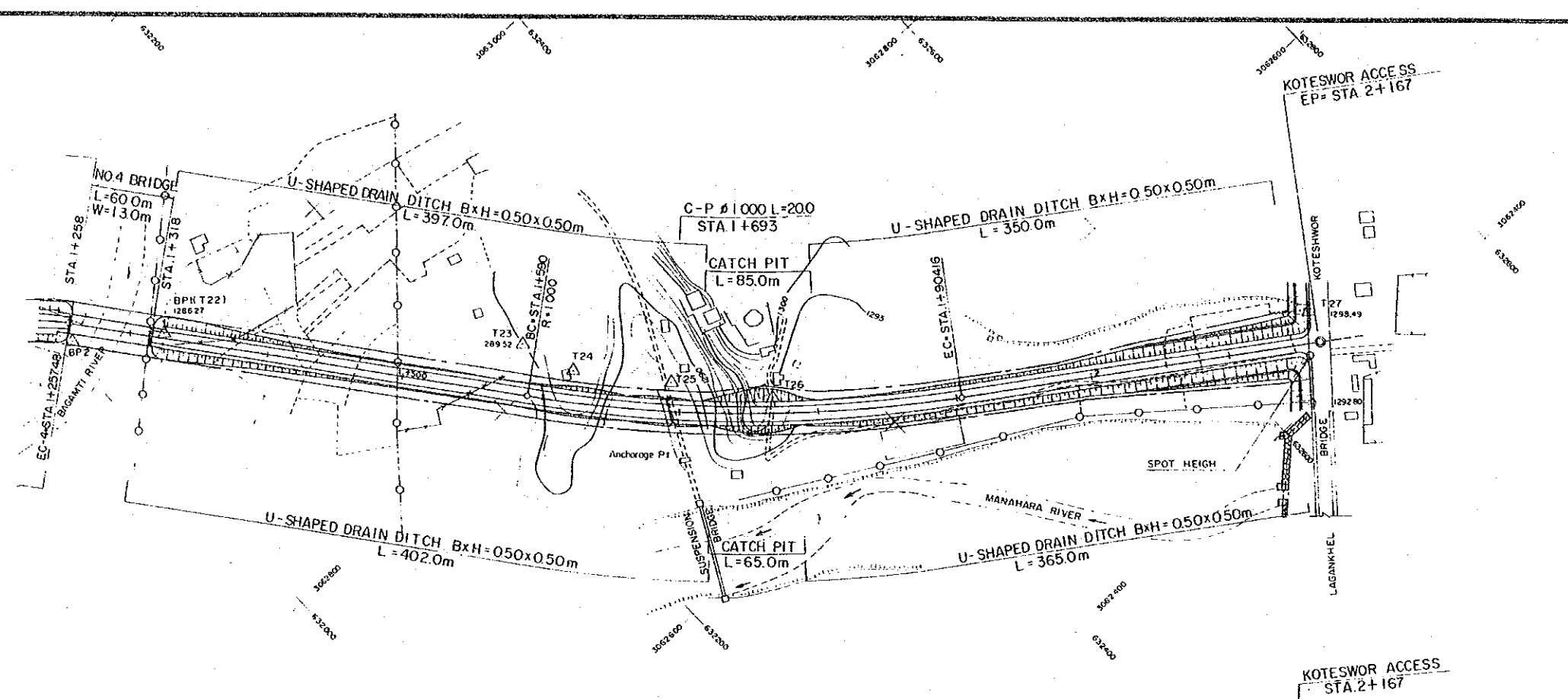

GRADIENT																
SUPER ELEVATION																
FORMATION HEIGHT																
GROUND HEIGHT																
STATION	250	300	350	400	450	500	550	600	650	700	750	800	850	900	950	100

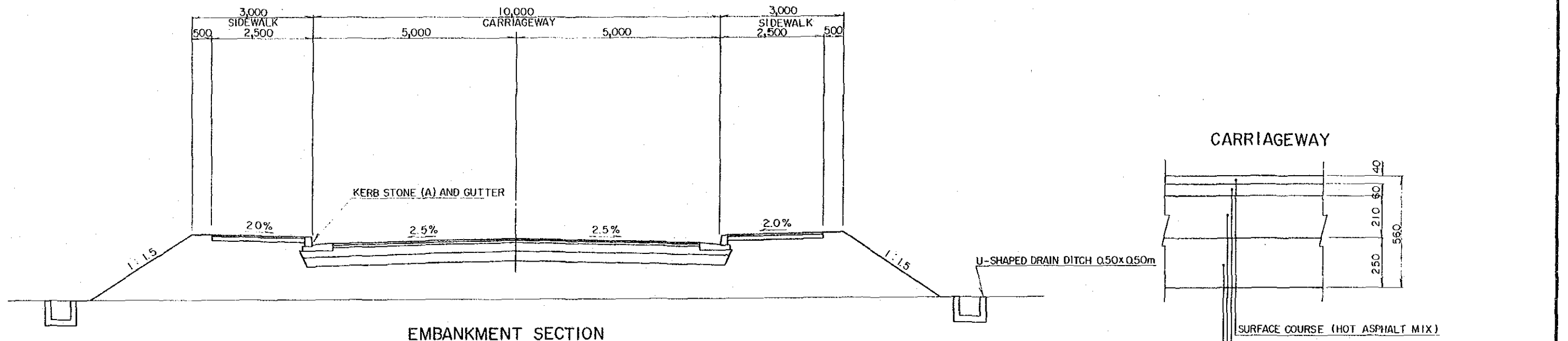

EMBAKMENT SECTION

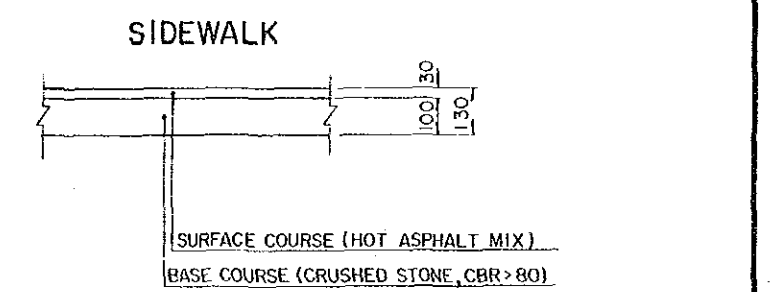
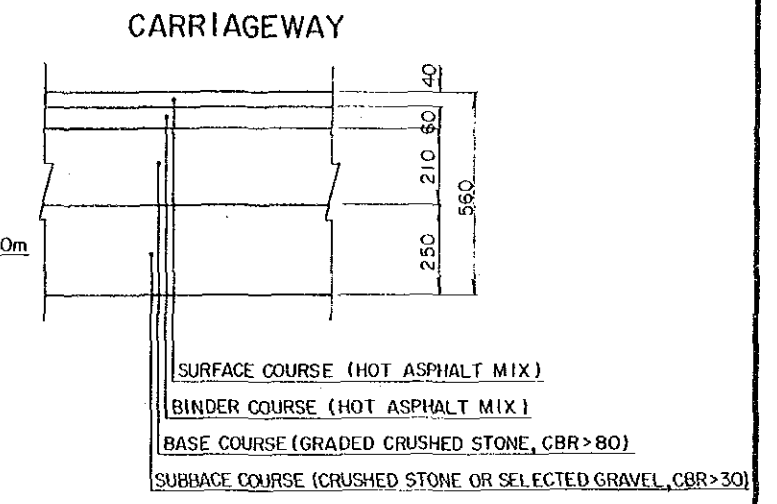

PAVEMENT STRUCTURES SCALE 1:10

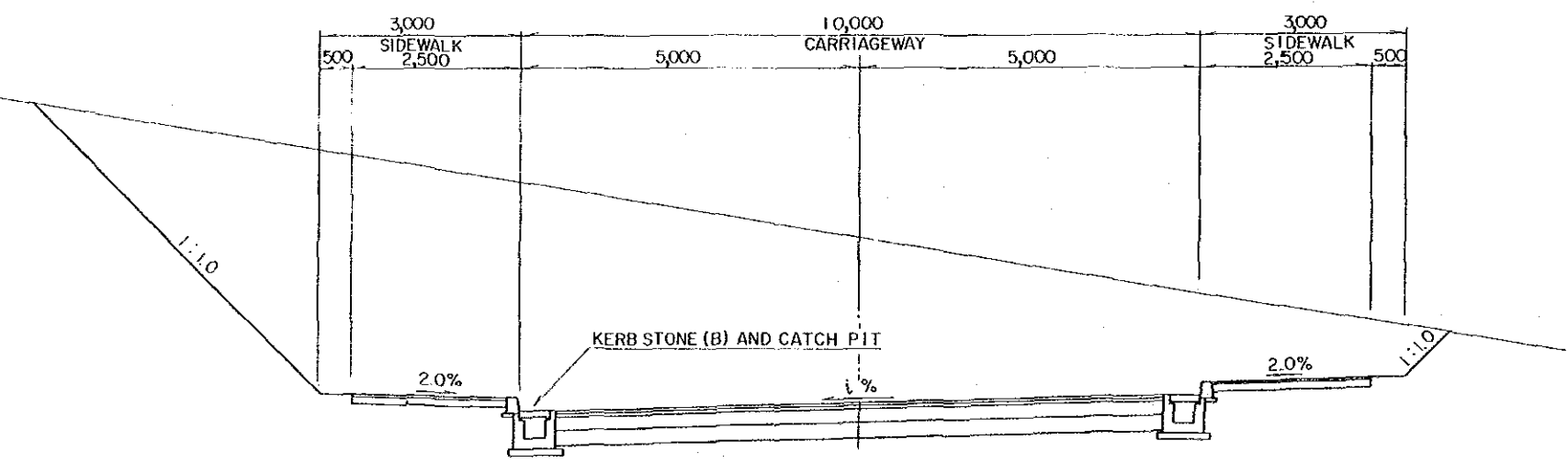

CUT SECTION

TYPICAL CROSS-SECTION OF KOTESWOR ACCESS SCALE 1:50

HIS MAJESTY'S GOVERNMENT OF NEPAL MINISTRY OF WORKS AND TRANSPORT DEPARTMENT OF ROADS	THE STUDY ON KATHMANDU VALLEY URBAN ROAD DEVELOPMENT	JAPAN INTERNATIONAL COOPERATION AGENCY	KOTESWOR ACCESS	DATE	SHEET NO.
			TYPICAL CROSS SECTION	MARCH 1993	24 / 40

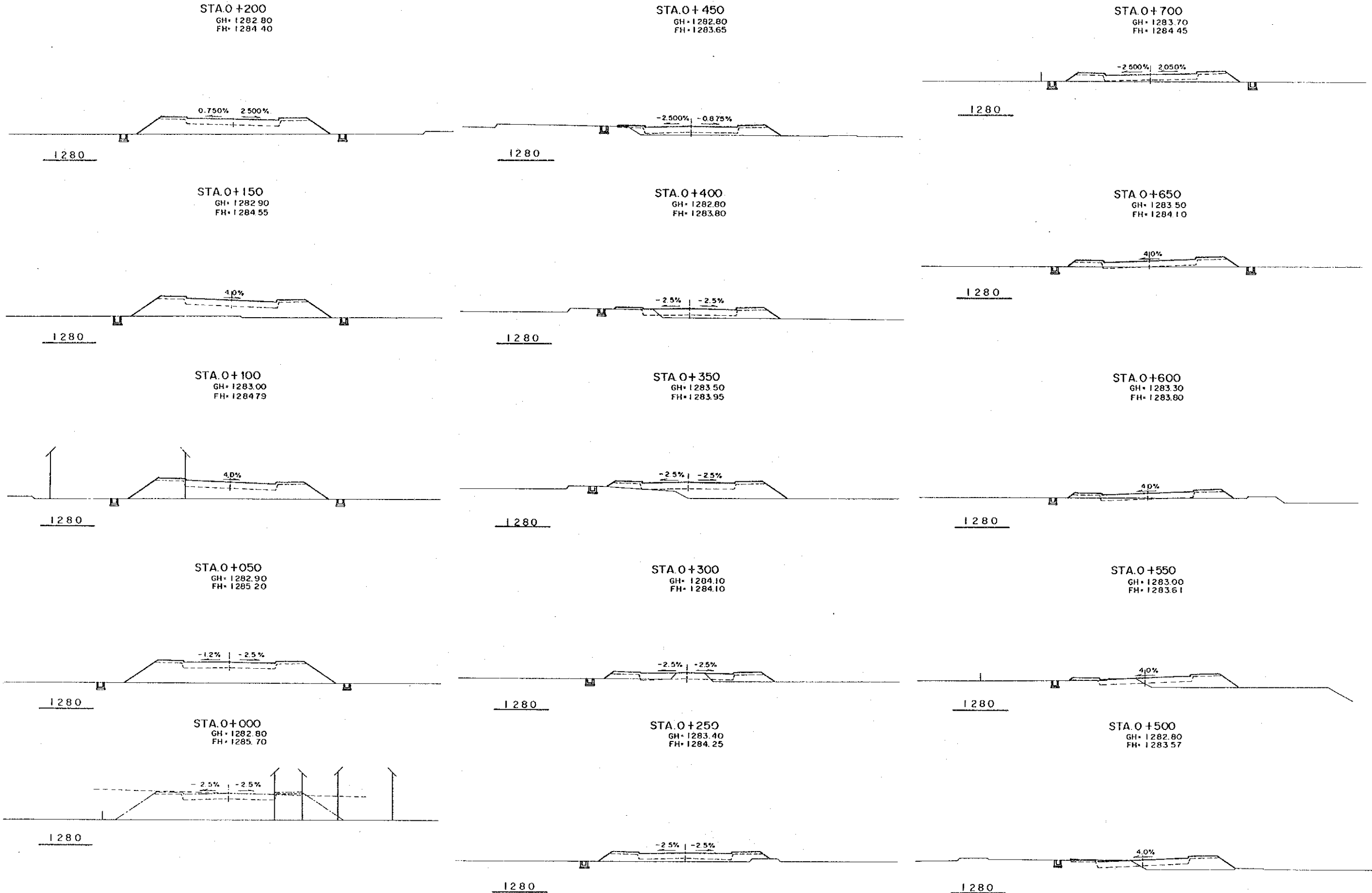

HIS MAJESTY'S GOVERNMENT OF NEPAL MINISTRY OF WORKS AND TRANSPORT DEPARTMENT OF ROADS	THE STUDY ON KATHIMANDU VALLEY URBAN ROAD DEVELOPMENT	JAPAN INTERNATIONAL COOPERATION AGENCY	KOTESWOR ACCESS	DATE	SHEET NO.
			CROSS SECTION (1)	MARCH 1993	25 40

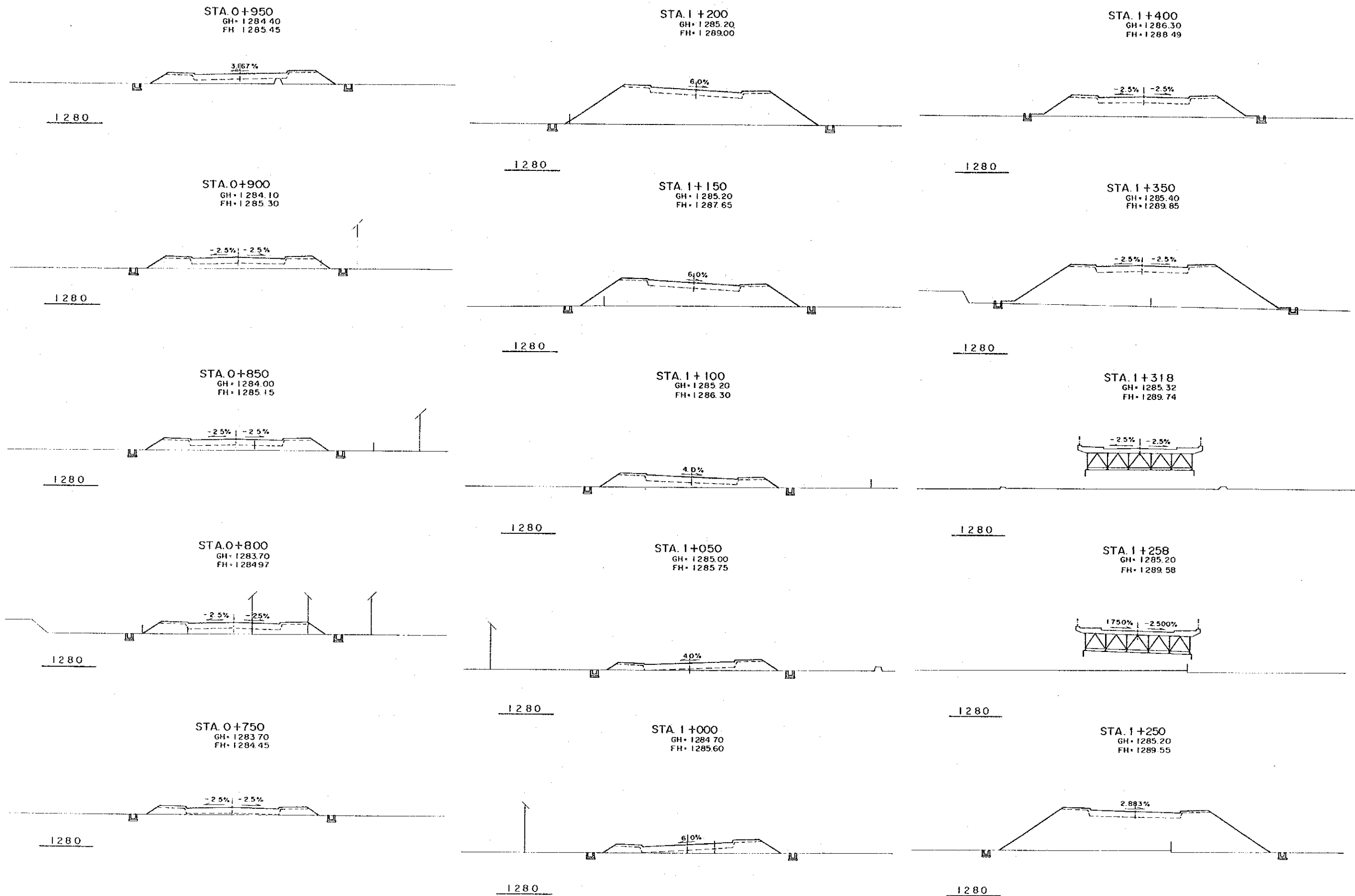

HIS MAJESTY'S GOVERNMENT OF NEPAL MINISTRY OF WORKS AND TRANSPORT DEPARTMENT OF ROADS	THE STUDY ON KATHMANDU VALLEY URBAN ROAD DEVELOPMENT	JAPAN INTERNATIONAL COOPERATION AGENCY	KOTESWOR ACCESS	DATE	SHEET NO.
			CROSS SECTION (2)	MARCH 1993	26 / 40

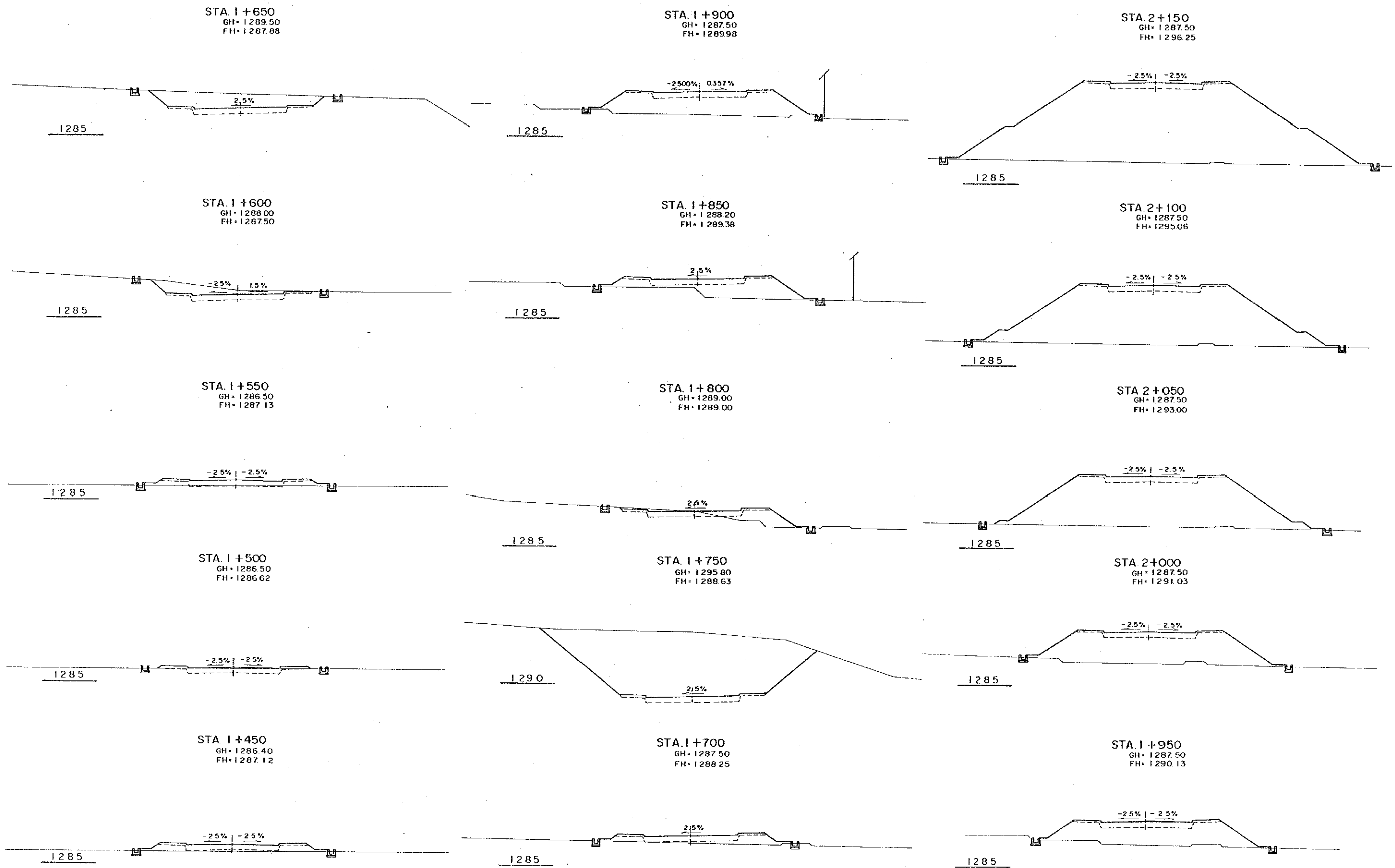

HIS MAJESTY'S GOVERNMENT OF NEPAL
 MINISTRY OF WORKS AND TRANSPORT
 DEPARTMENT OF ROADS

THE STUDY
 ON
 KATHMANDU VALLEY URBAN ROAD DEVELOPMENT

JAPAN INTERNATIONAL
 COOPERATION AGENCY

KOTESWOR ACCESS
 CROSS SECTION (3)

DATE	SHEET NO.
MARCH 1993	27 / 40

BAGMATI BRIGE No.4

GENERAL ELEVATION

S = 1 : 200

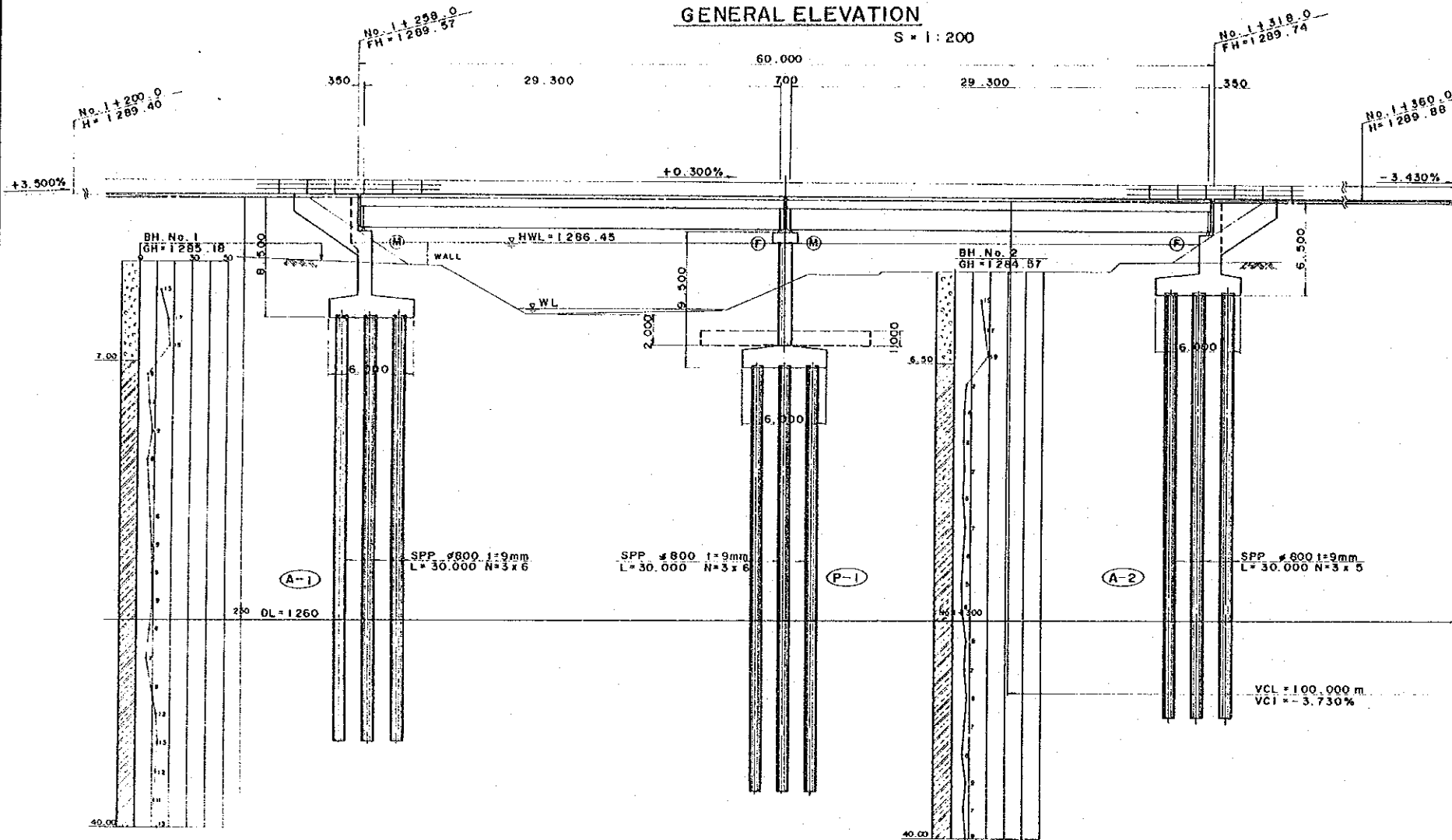

CROSS SECTION

S = 1 : 100

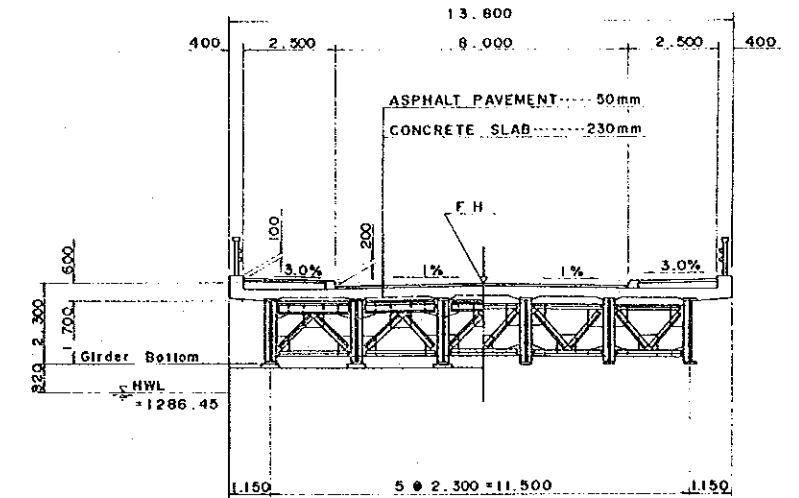

GENERAL PLAN

S = 1 : 200

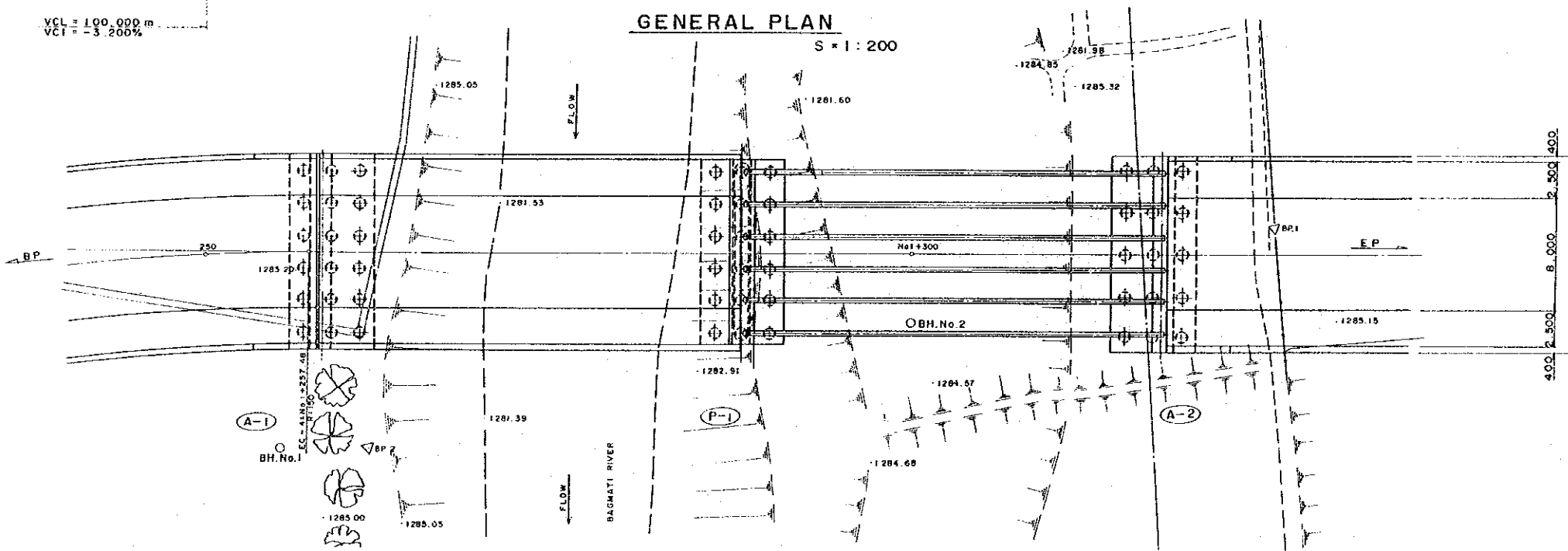

HIS MAJESTY'S GOVERNMENT OF NEPAL
MINISTRY OF WORKS AND TRANSPORT
DEPARTMENT OF ROADS

THE STUDY
ON
KATHMANDU VALLEY URBAN ROAD DEVELOPMENT

JAPAN INTERNATIONAL
COOPERATION AGENCY

KOTESWOR ACCESS
No.4 BRIDGE

DATE	SHEET NO.
MARCH 1993	28 / 40

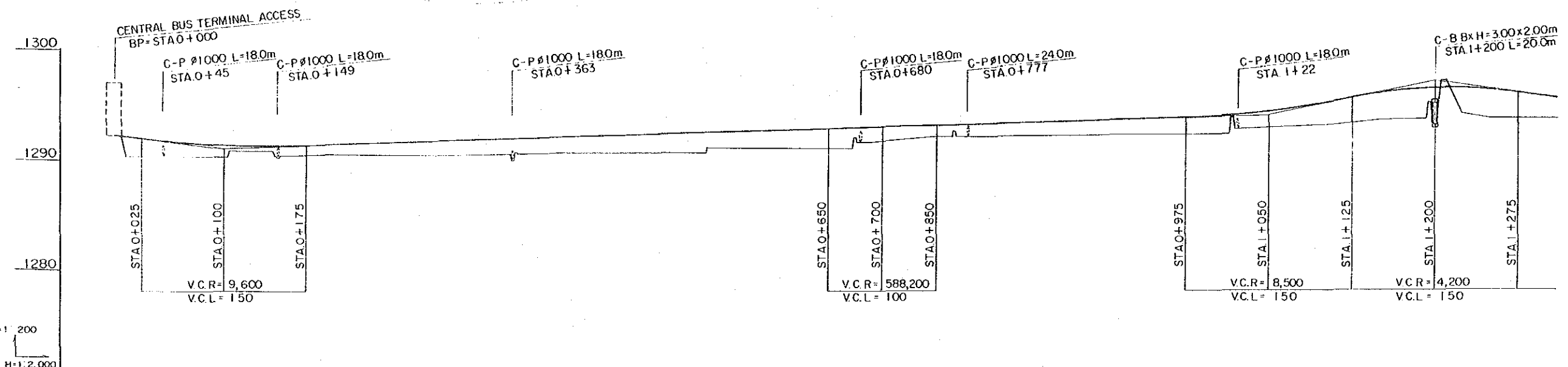
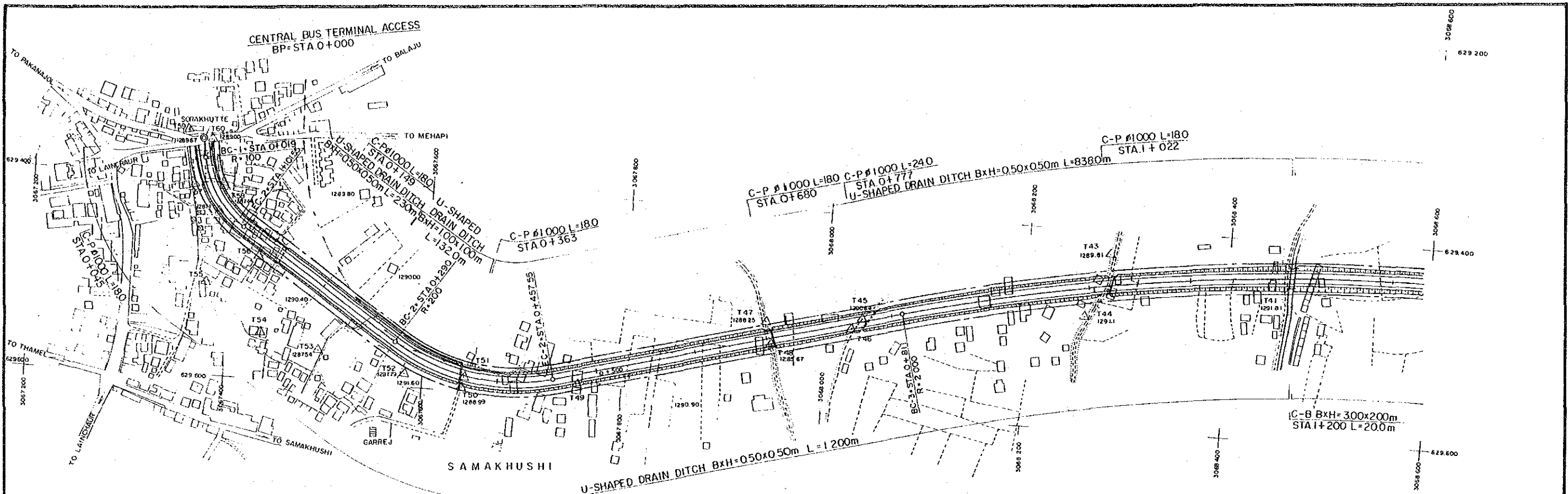

GRADIENT	-2.500%		0.317%										0.300%										2.067%		-1.500%			
SUPER ELEVATION	8%		5.000%																									
FORMATION HEIGHT	1292.20	1291.61	1291.24	1291.14	1291.27	1291.43	1291.58	1291.74	1291.90	1292.06	1292.22	1292.38	1292.54	1292.69	1292.84	1293.00	1293.15	1293.30	1293.45	1293.60	1293.94	1294.23	1294.97	1295.90	1296.33	1296.18	1295.54	
GROUND HEIGHT	1292.20	1290.30	1290.20	1290.30	1290.40	1290.30	1290.30	1290.40	1290.50	1290.50	1290.50	1290.90	1290.90	1290.90	1291.50	1292.00	1292.00	1292.10	1292.10	1292.10	1292.20	1292.80	1293.00	1293.00	1293.60	1293.60	1293.60	1293.60
STATION	0+000	50	100	150	200	250	300	350	400	450	500	550	600	650	700	750	800	850	900	950	1000	1050	1100	1150	1200	1250	1300	

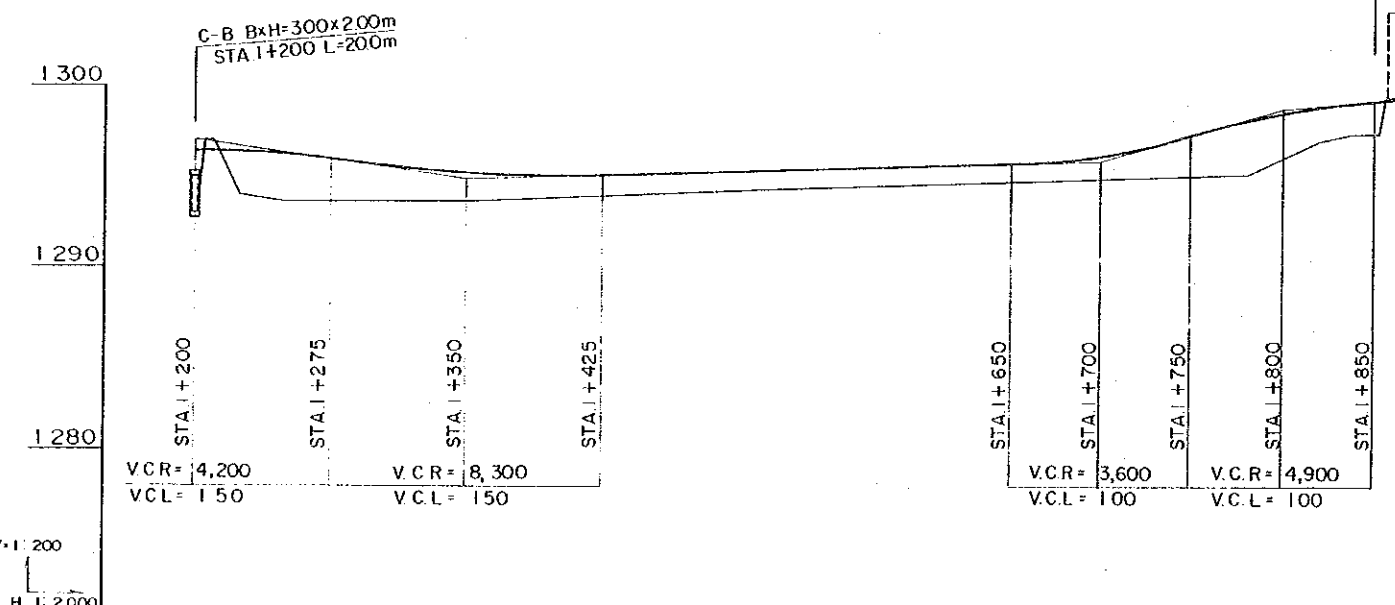
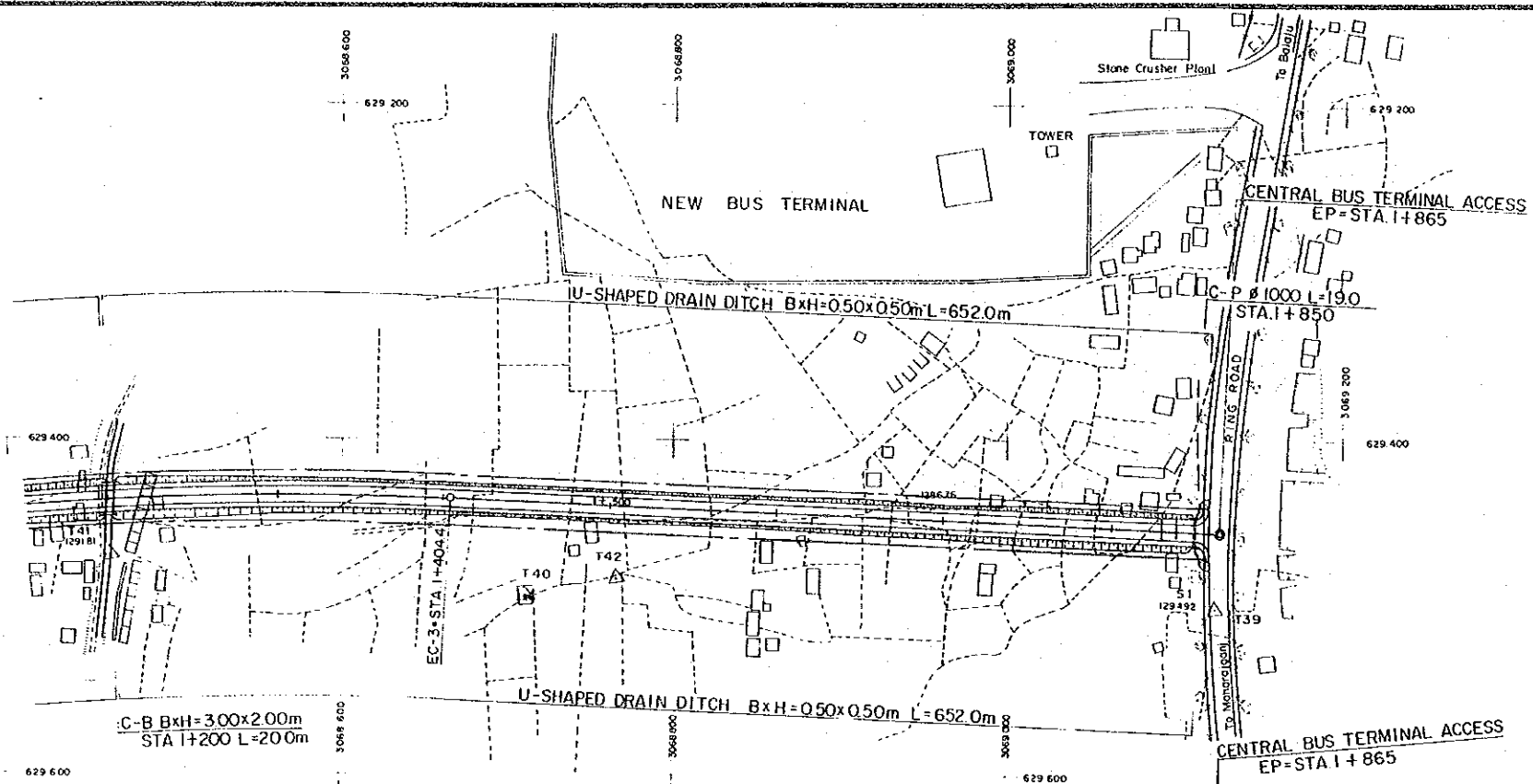

GRADIENT															
SUPER ELEVATION															
FORMATION HEIGHT	200	250	300	350	400	450	500	550	600	650	700	750	800	850	865
GROUND HEIGHT	1293.00	1293.60	1293.60	1293.60	1293.80	1294.00	1294.20	1294.40	1294.60	1294.70	1294.90	1295.00	1296.00	1297.40	1299.50
STATION	200	250	300	350	400	450	500	550	600	650	700	750	800	850	865

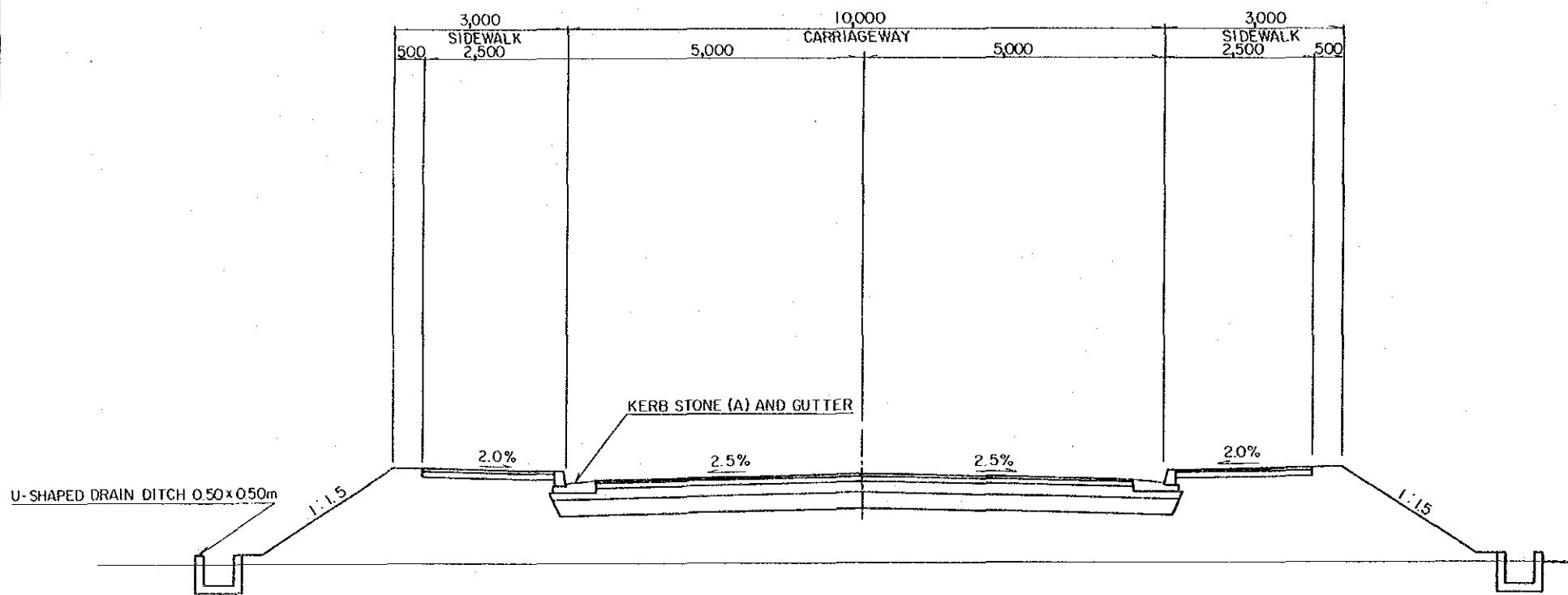

TYPICAL CROSS-SECTION OF CENTRAL BUS TERMINAL ACCESS SCALE 1:50

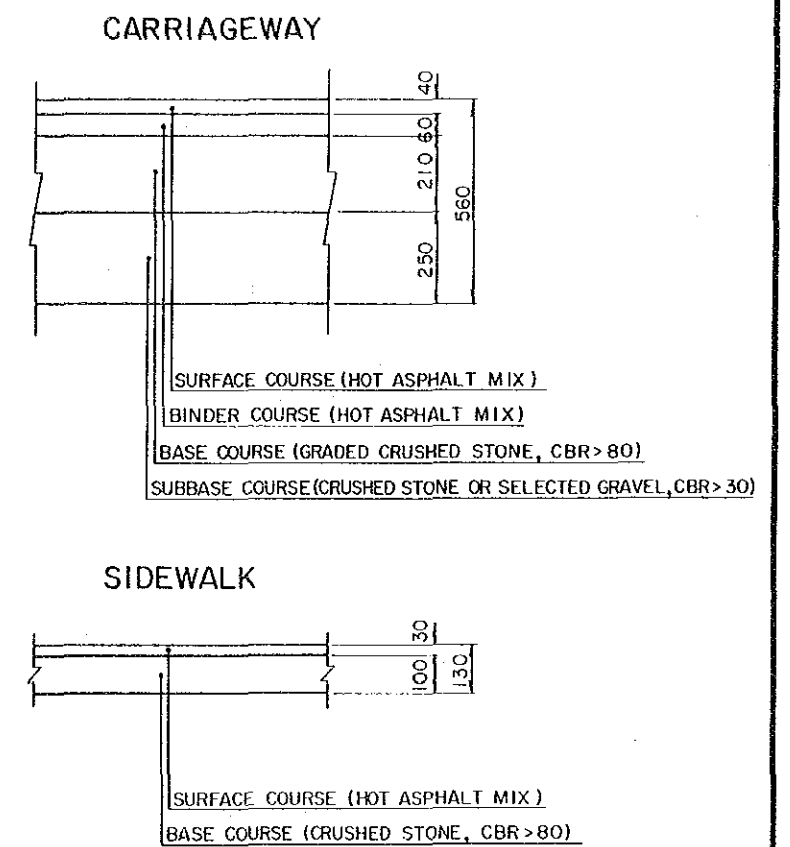

PAVEMENT STRUCTURES SCALE 1:10

HIS MAJESTY'S GOVERNMENT OF NEPAL MINISTRY OF WORKS AND TRANSPORT DEPARTMENT OF ROADS	THE STUDY ON KATHMANDU VALLEY URBAN ROAD DEVELOPMENT	JAPAN INTERNATIONAL COOPERATION AGENCY	CENTRAL BUS TERMINAL ACCESS	DATE	SHEET NO.
			TYPICAL CROSS SECTION	MARCH 1993	31 40

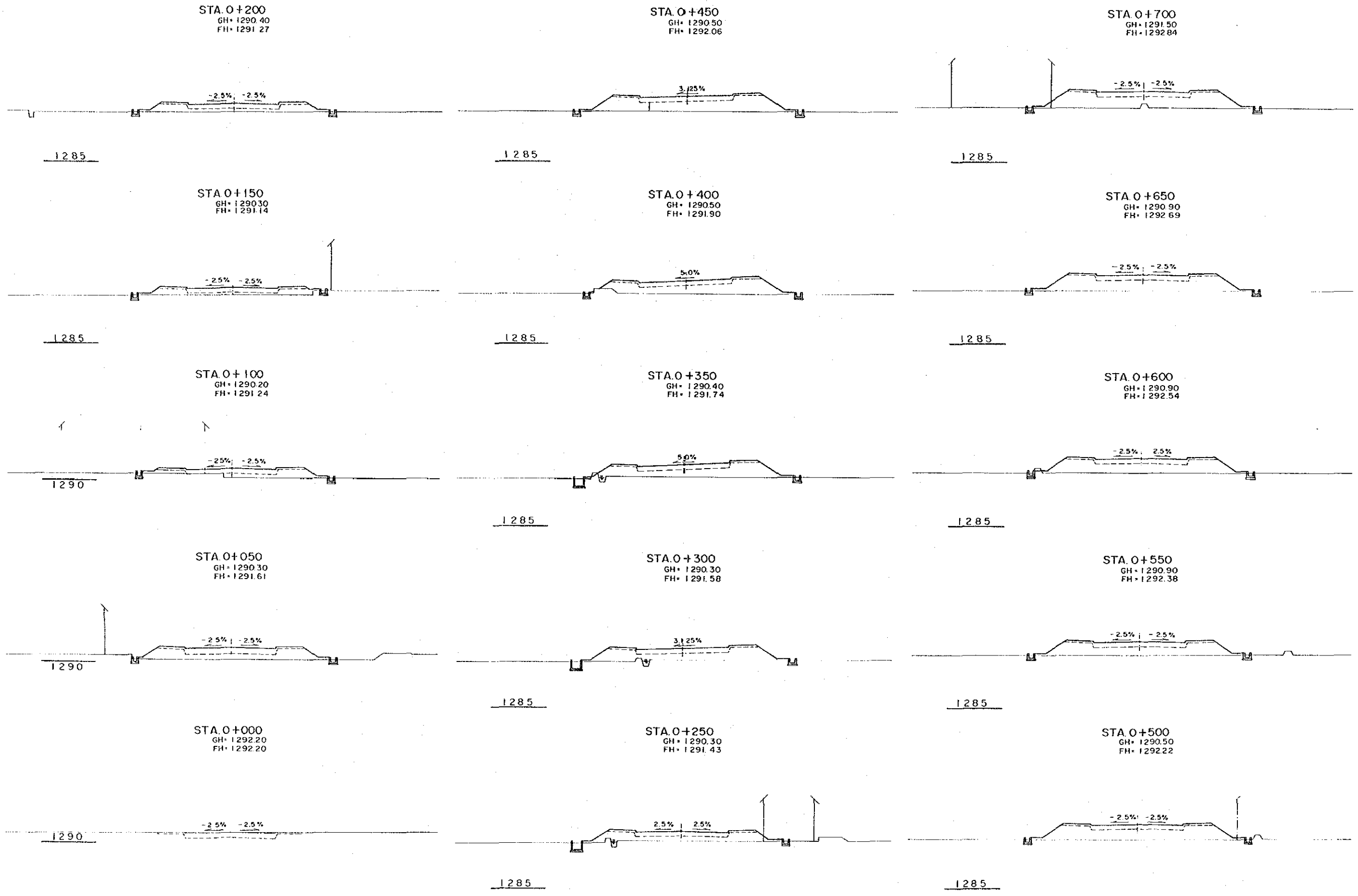

HIS MAJESTY'S GOVERNMENT OF NEPAL MINISTRY OF WORKS AND TRANSPORT DEPARTMENT OF ROADS	THE STUDY ON KATHMANDU VALLEY URBAN ROAD DEVELOPMENT	JAPAN INTERNATIONAL COOPERATION AGENCY	CENTRAL BUS TERMINAL ACCESS	DATE	SHEET NO.
			CROSS SECTION (I)	MARCH 1993	32 / 40

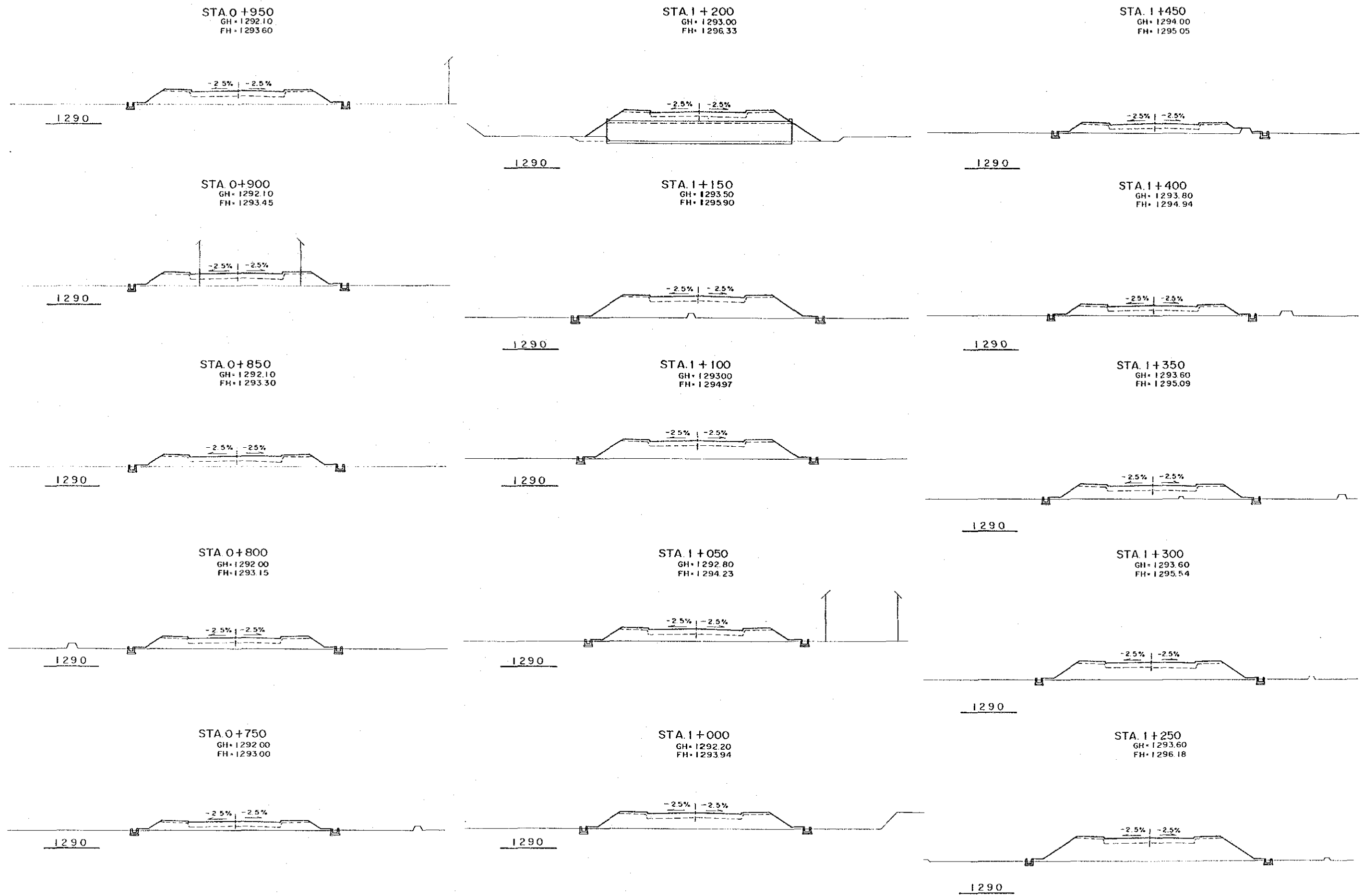

HIS MAJESTY'S GOVERNMENT OF NEPAL MINISTRY OF WORKS AND TRANSPORT DEPARTMENT OF ROADS	THE STUDY ON KATHMANDU VALLEY URBAN ROAD DEVELOPMENT	JAPAN INTERNATIONAL COOPERATION AGENCY	CENTRAL BUS TERMINAL ACCESS	DATE	SHEET NO.
			CROSS SECTION (2)	MARCH 1993	33 / 40

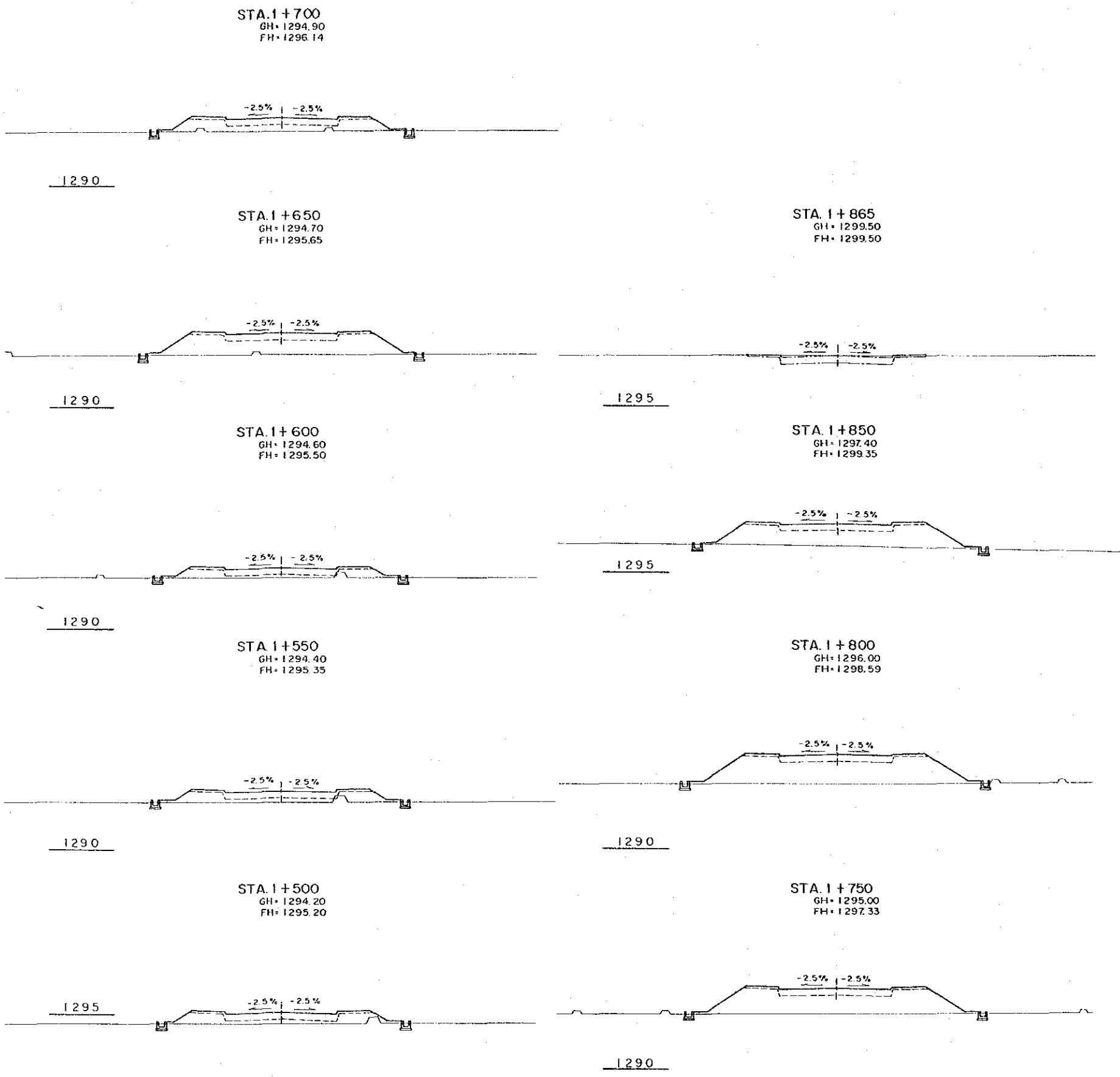

HIS MAJESTY'S GOVERNMENT OF NEPAL MINISTRY OF WORKS AND TRANSPORT DEPARTMENT OF ROADS	THE STUDY ON KATHMANDU VALLEY URBAN ROAD DEVELOPMENT	JAPAN INTERNATIONAL COOPERATION AGENCY	CENTRAL BUS TERMINAL ACCESS	DATE	SHEET NO.
			CROSS SECTION (3)	MARCH 1993	34 40

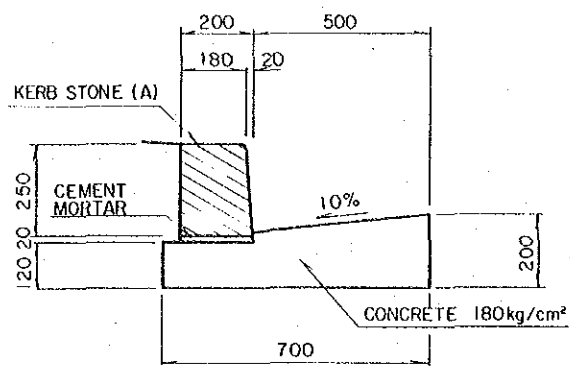

KARB STONE (A) AND GUTTER SCALE 1:10

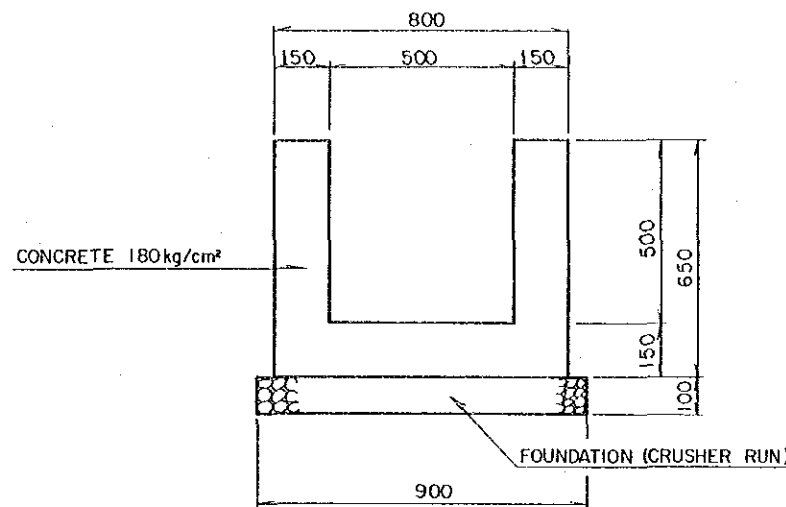

U-SHAPED DRAIN DITCH 0.5x0.5m SCALE 1:10

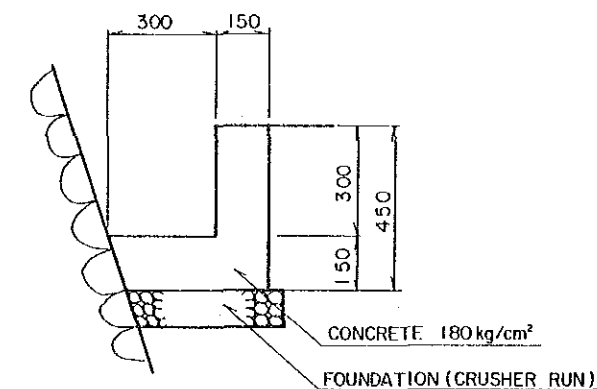

U-SHAPED DRAIN DITCH 0.3x0.3m
SCALE 1:10

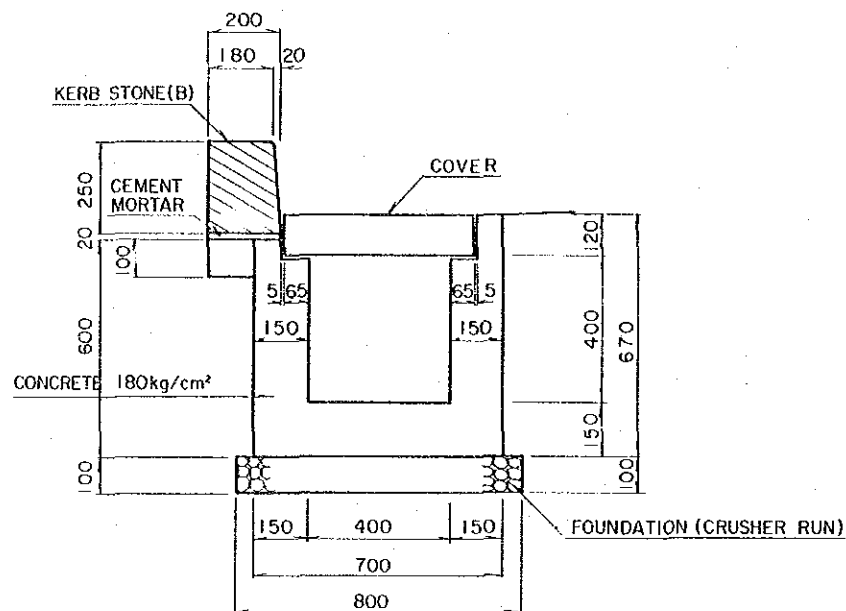

KERB STONE (A) AND CATCH PIT SCALE 1:10

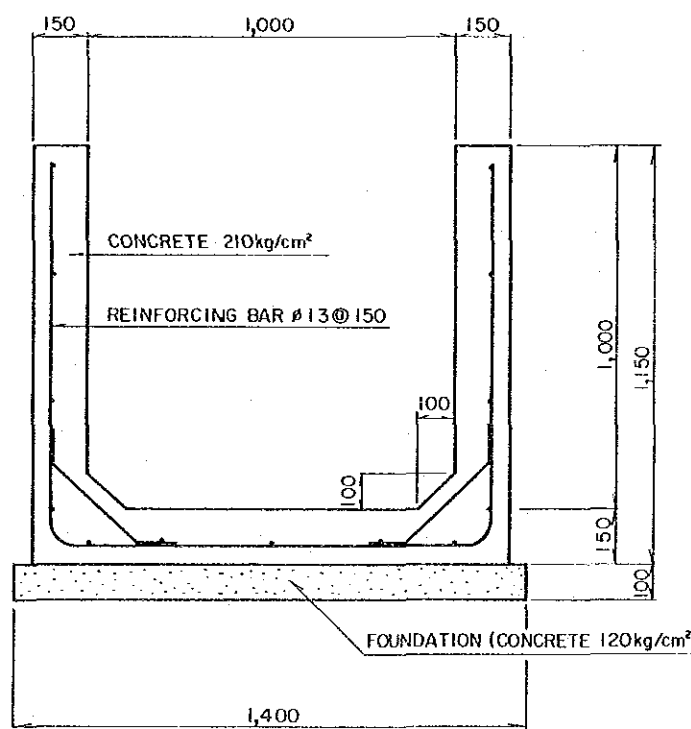

U-SHAPED DRAIN DITCH 1.0x1.0m SCALE 1:10

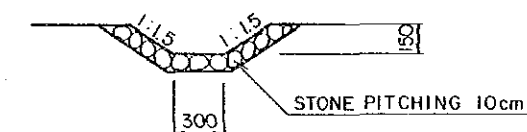

SIDE DRAIN WITH STONE PITCHING
SCALE 1:20

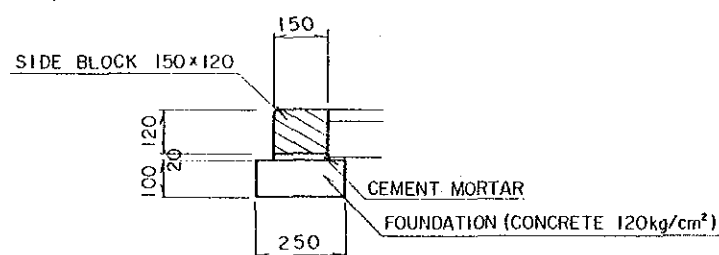

SIDE BLOCK SCALE 1:10

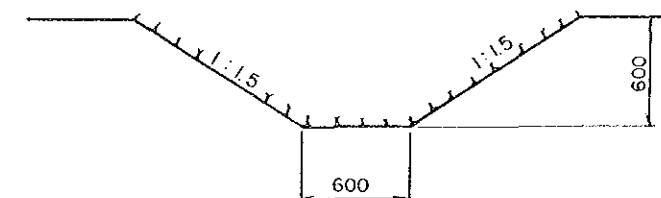

SIDE DRAIN SCALE 1:20

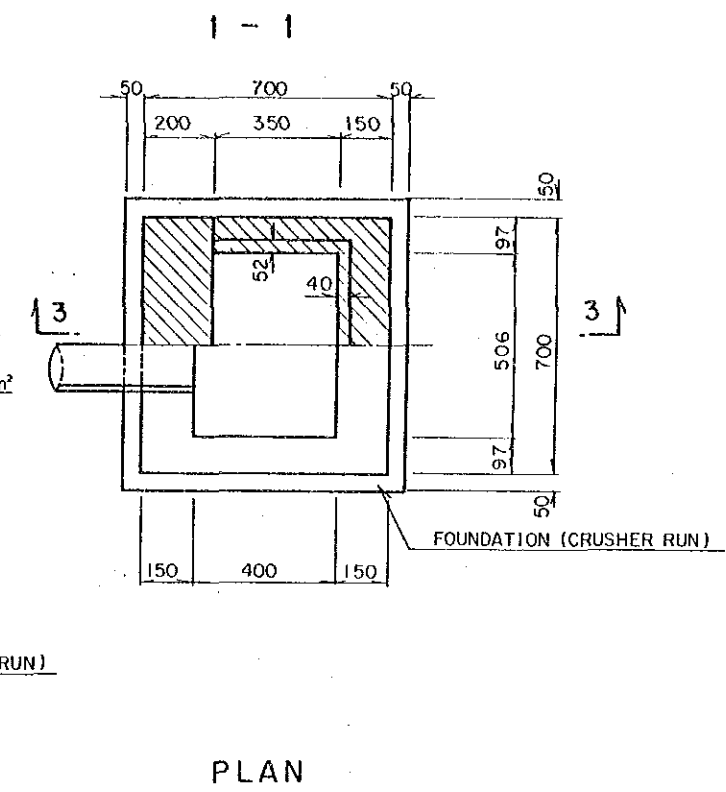
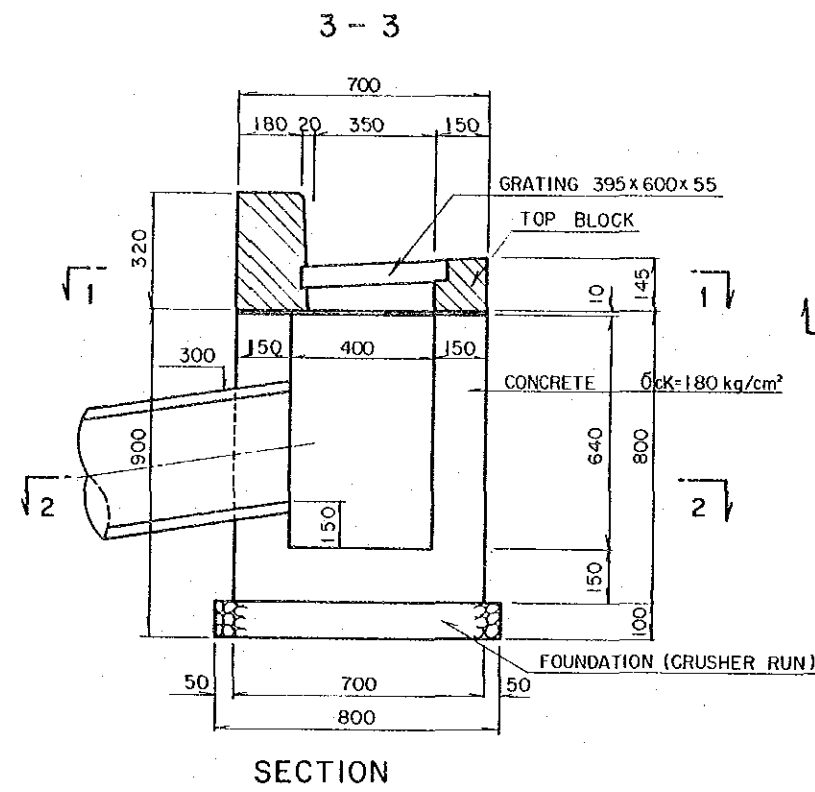
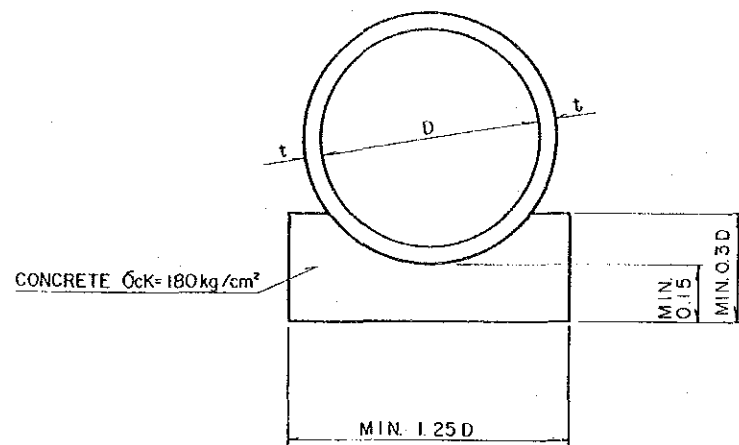

CATCH BASIN (SCALE: 1/10)

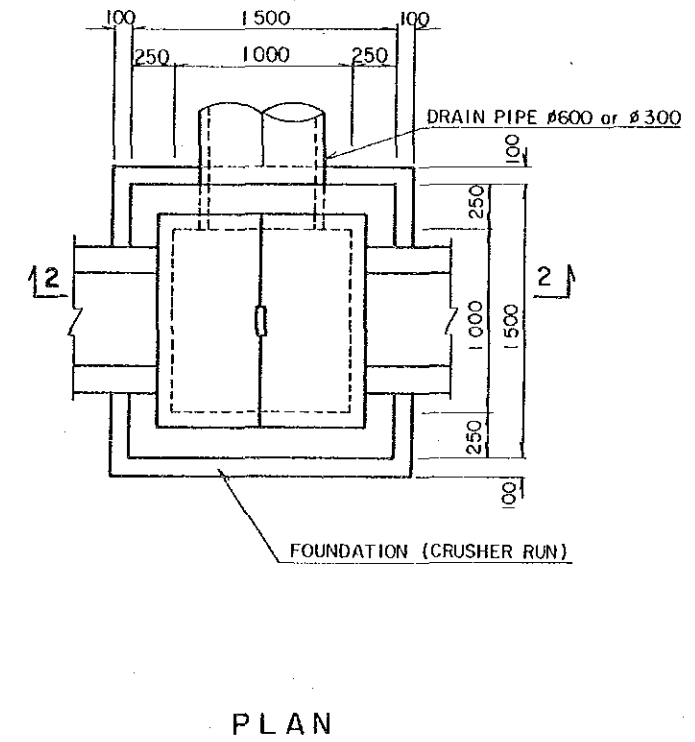
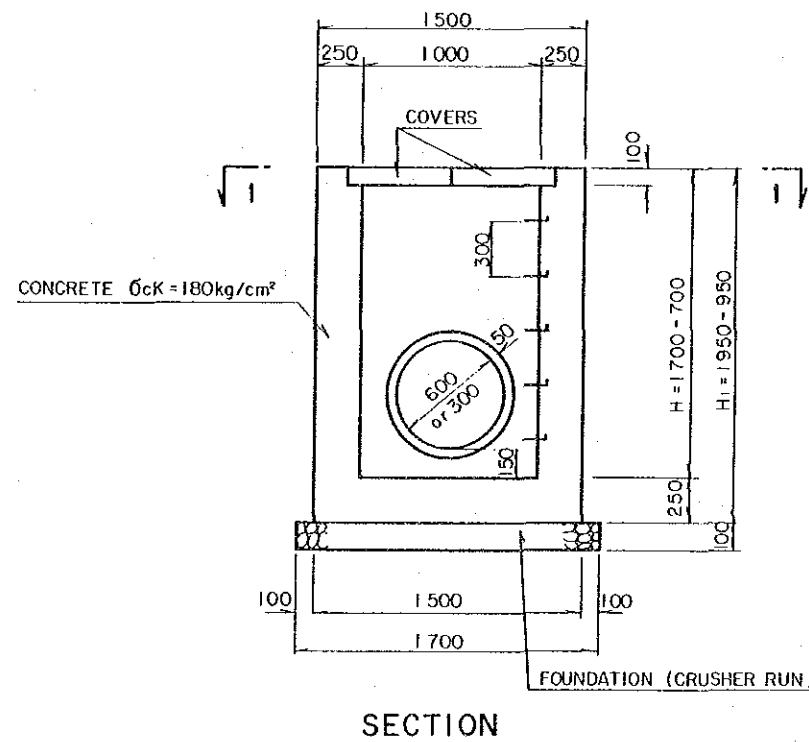

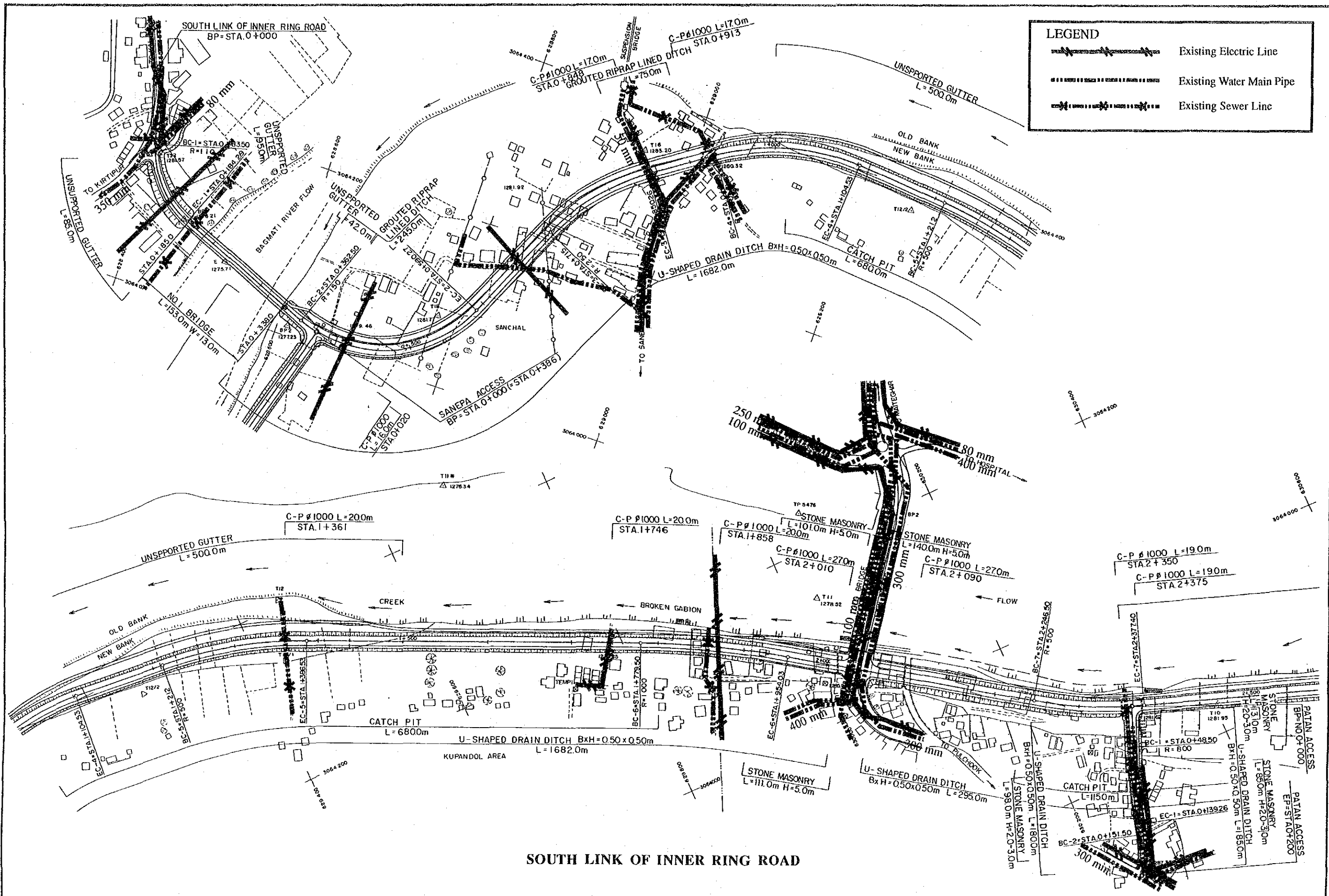

MANHOLE (SCALE: 1/10)



SOUTH LINK OF INNER RING ROAD

HIS MAJESTY'S GOVERNMENT OF NEPAL MINISTRY OF WORKS AND TRANSPORT DEPARTMENT OF ROADS	THE STUDY ON KATHMANDU VALLEY URBAN ROAD DEVELOPMENT	JAPAN INTERNATIONAL COOPERATION AGENCY	UTILITIES (1)	DATE MARCH 1993	SHEET NO. 37 40
---	--	---	----------------------	-----------------------	-----------------------

LEGEND

-  Existing Electric Line
-  Existing Water Main Pipe
-  Existing Sewer Line

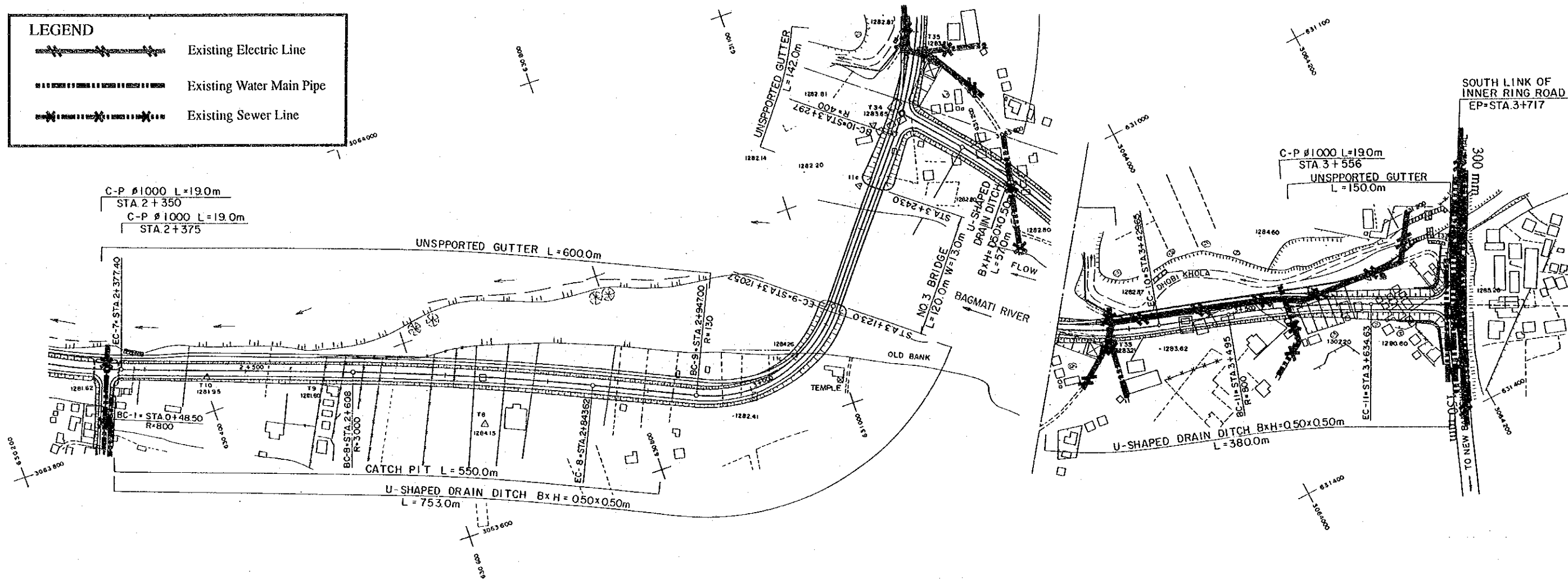

SOUTH LINK OF INNER RING ROAD

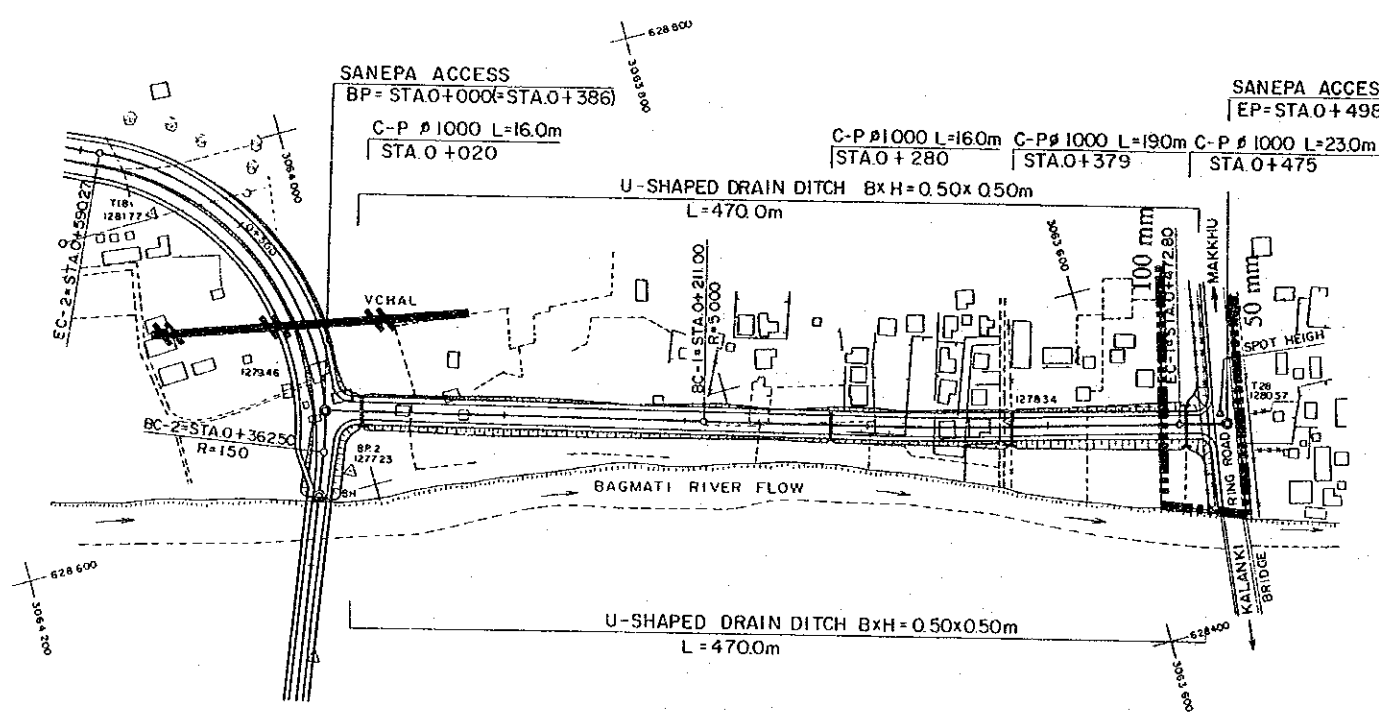

SANEPA ACCESS

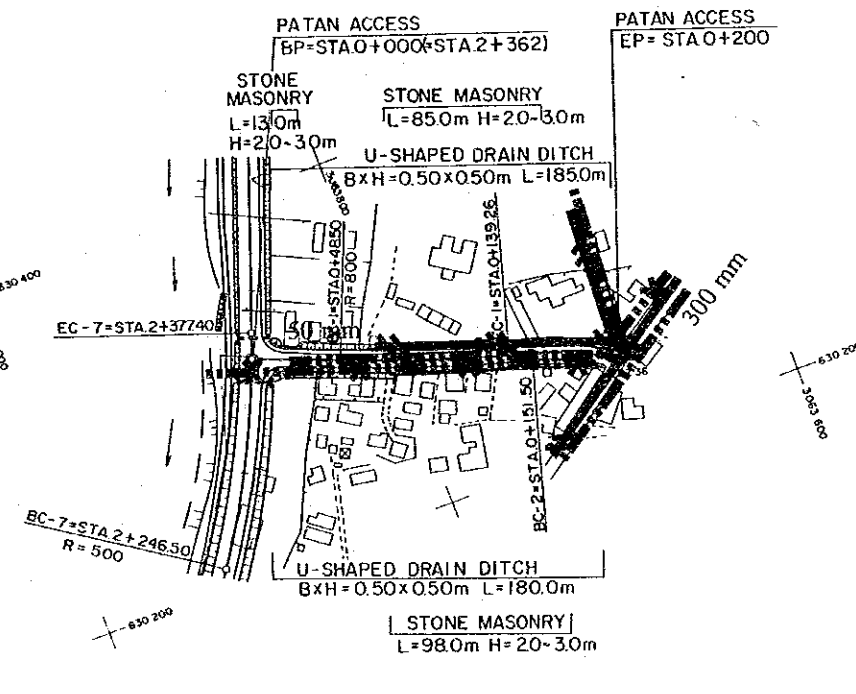

PATAN ACCESS

HIS MAJESTY'S GOVERNMENT OF NEPAL MINISTRY OF WORKS AND TRANSPORT DEPARTMENT OF ROADS	THE STUDY ON KATHMANDU VALLEY URBAN ROAD DEVELOPMENT	JAPAN INTERNATIONAL COOPERATION AGENCY	UTILITIES (2)	DATE	SHEET NO.
				MARCH	38
				1993	40

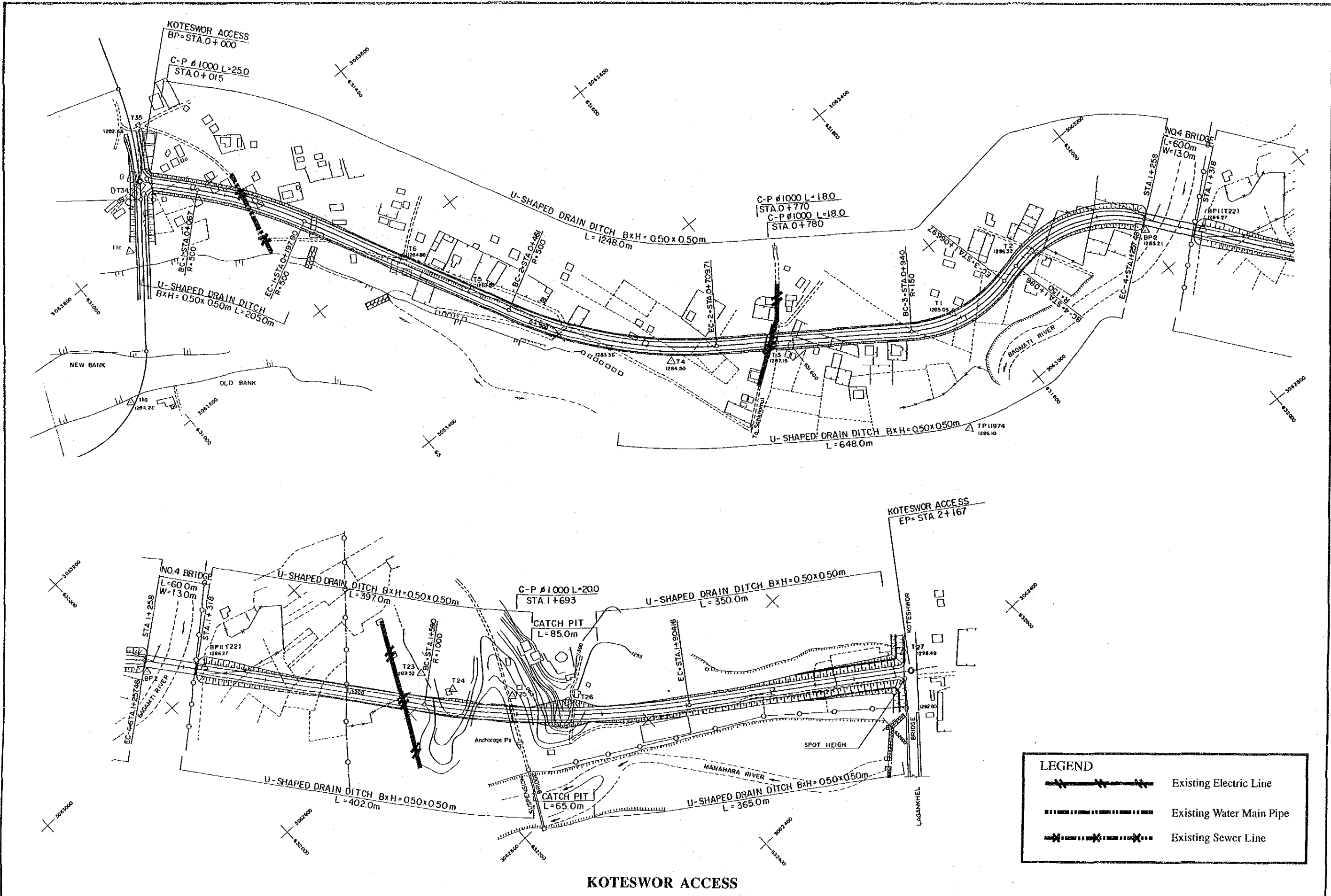

KOTESWOR ACCESS

HIS MAJESTY'S GOVERNMENT OF NEPAL
 MINISTRY OF WORKS AND TRANSPORT
 DEPARTMENT OF ROADS

THE STUDY
 ON
 KATHMANDU VALLEY URBAN ROAD DEVELOPMENT

JAPAN INTERNATIONAL
 COOPERATION AGENCY

UTILITIES (3)

DATE	SHEET NO.
MARCH 1993	39 / 40

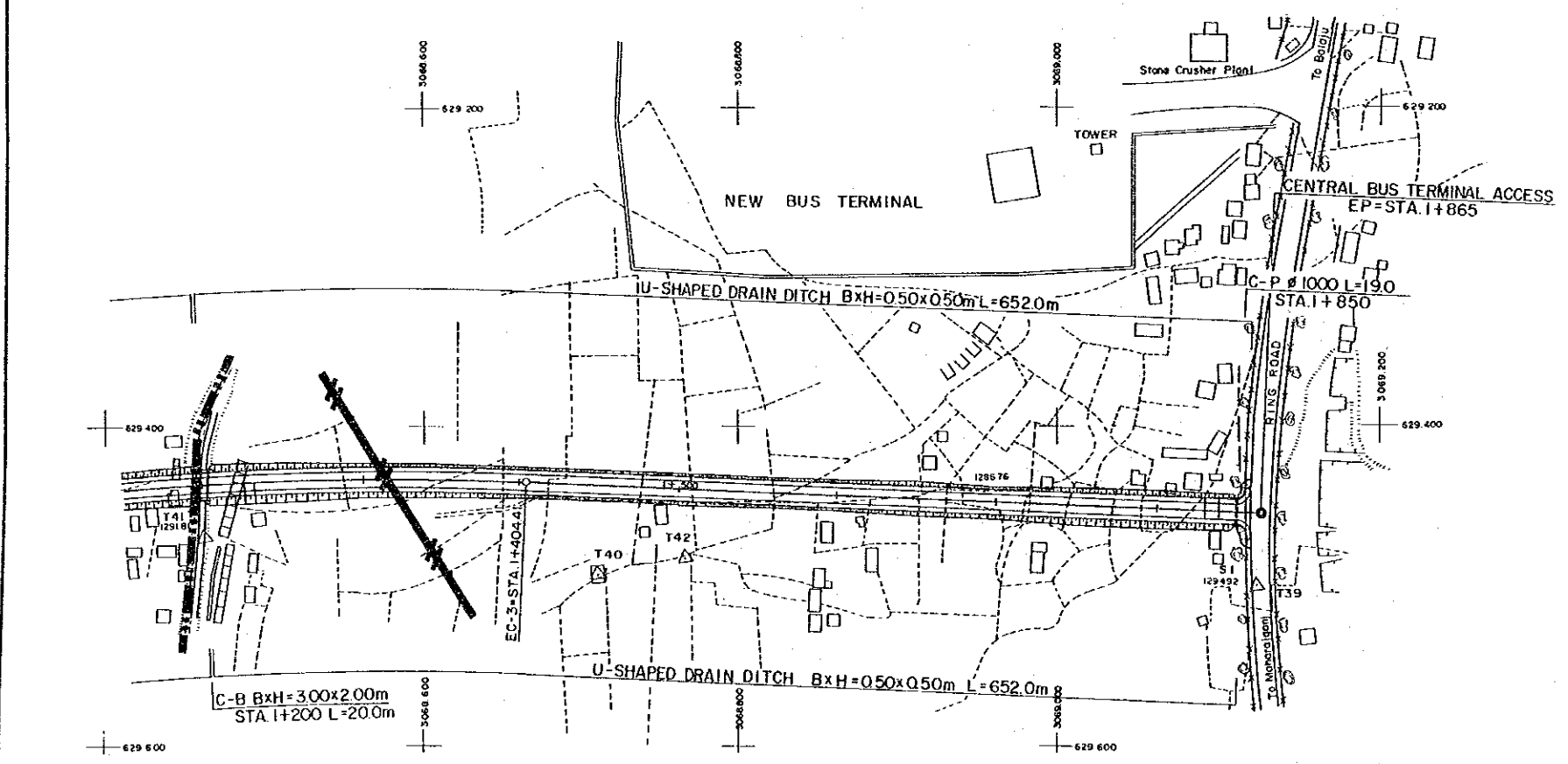
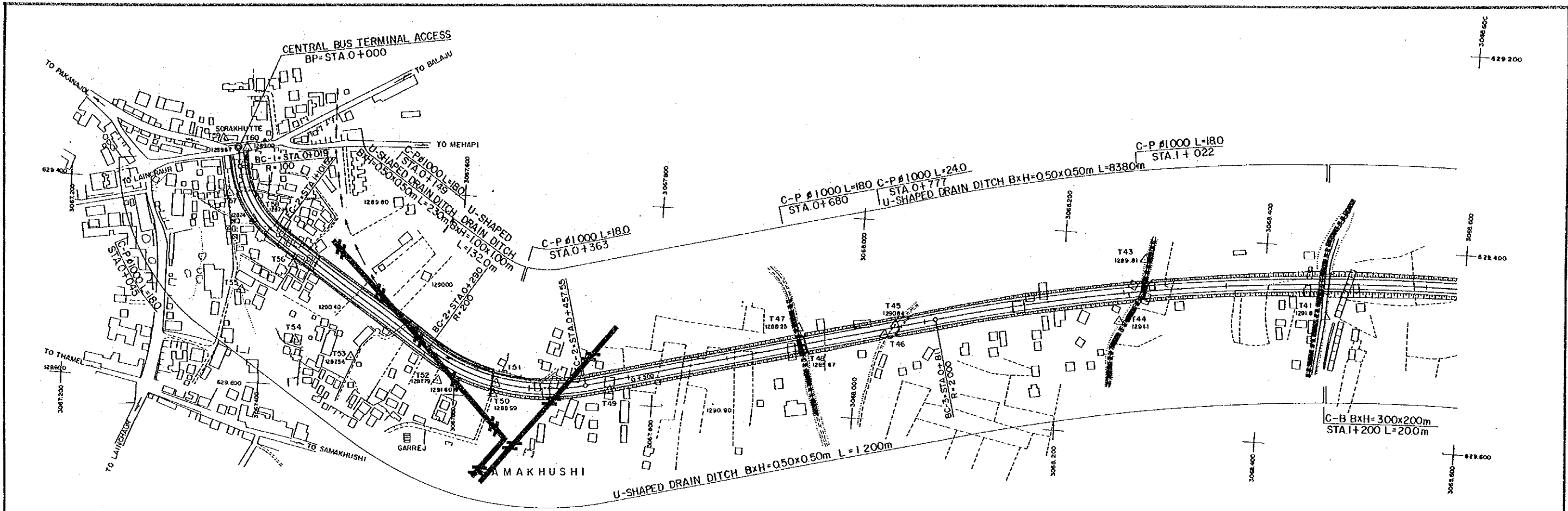

LEGEND	
	Existing Electric Line
	Existing Water Main Pipe
	Existing Sewer Line

CENTRAL BUS TERMINAL ACCESS

HIS MAJESTY'S GOVERNMENT OF NEPAL MINISTRY OF WORKS AND TRANSPORT DEPARTMENT OF ROADS	THE STUDY ON KATHMANDU VALLEY URBAN ROAD DEVELOPMENT	JAPAN INTERNATIONAL COOPERATION AGENCY	UTILITIES (4)	DATE	SHEET NO.
				MARCH 1993	40 40

JICA