

No. 5

JAPAN INTERNATIONAL COOPERATION AGENCY (JICA)

MINISTRY OF WORKS AND ENERGY

REPUBLIC OF KIRIBATI

A STUDY OF UTILIZATION
 OF
 PHOTOVOLTAICS
 FOR
 RURAL ELECTRIFICATION
 IN
 THE REPUBLIC OF KIRIBATI
 FINAL REPORT
 ATTACHMENT-I

MARCH 1994

YONDEN CONSULTANTS CO., LTD.

MPN
J R
94-085

MINISTRY OF WORKS AND ENERGY
REPUBLIC OF KIRIBATI

A STUDY OF UTILIZATION OF PHOTOVOLTAICS FOR
RURAL ELECTRIFICATION IN THE REPUBLIC OF KIRIBATI

MARCH 1994

YONDEN CONSULTANTS CO.

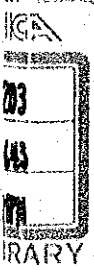

JICA LIBRARY



1119192(1)

27484

JAPAN INTERNATIONAL COOPERATION AGENCY (JICA)

No.

MINISTRY OF WORKS AND ENERGY

REPUBLIC OF KIRIBATI

A STUDY OF UTILIZATION
OF
PHOTOVOLTAICS
FOR
RURAL ELECTRIFICATION
IN
THE REPUBLIC OF KIRIBATI
FINAL REPORT
ATTACHMENT- I
FINAL REPORT

MARCH 1994

YONDEN CONSULTANTS CO., LTD.

MPN

J R

94-087

国際協力事業団

27484

The Rural Electrification of Republic of Kiribati

Photovoltaic System Facility List

The List of Light Installation Customer

VILLAGE	NO	CODE NO	CUSTOMER NAME	REMARK
TARATAI	1	R 17	Tetika	
	2		Tabobo	
NOTOUE	1	N 1	Arebonto	
	2	N 3	Bentara	
	3	N10	Keeti	
	4	N16	Mikaere Timaiia	
	5	N30	Terinaki	
	6	N32	Tikanro	
	7	N35	Utimawa	
	8	N36	Waire	
	9	N37	Iotebwa	
	10	N38	Airin	
	11		Roniiti Tetabo	
	12		Taukaban Ioane	
	13		Tamuera Karebanga	
	14		Tebike Neneia	
	15		Tiibau	
ABAOKORO	1	A 1	Abakuka	
	2	A 4	Beia Toara	
	3	A 5	Ekeieta Ititaake	
	4	A 9	Loui Namane	
	5	A10	Natiria Tamton	
	6	A11	Obeta	
	7	A16	Tebarine Boobu	
	8	A17	Tebuaka	
	9	A18	Tekakiabo	
	10	A21	Temarawa Kawitu	
	11	A27	Makin Ngatau	
	12	A29	Taukaban	
	13	A32	Ribati (KPC)	
	14	A33	Boua Tekaa	
	15	A35	Abaua	
	16	A36	Bwenawa	
	17	A37	Matiota	
	18		Ambou	
	19		Bauro (Tika)	
	20		Kaobunang	
	21		Tekatau	
	22		Tekeraoi	
	23		Tenagimau (TEACHER)	
	24		Tetake	
	25		Biita	
MARENANUKA	1	M 1	Beia Ruaia	
	2	M 4	Moaukea	
	3	M 7	Ten Taateraka	
TABONIBARA	1	T 6	Rabangaki Matimara	
	2	T18	Toani Takaio	
	3	T23	Teaoti Ngoia	
	4		Maeuea	
	5		Tabeia	
	6		Tutu Tiribo	
KAINABA	1	K 4	Birikaua Tabokai	
	2	K10	Taake Tetaua	
	3	K11	Tebuatei Abiete	
	4	K14	Ueanna Temanikaai	
			Maneaba	

File of PV system Facility for Private House

1. Name of householder : T e n T e t i k a
2. Code NO : R 1 7
3. Name of village : T a r a t a i
4. Drawing of PV Facility

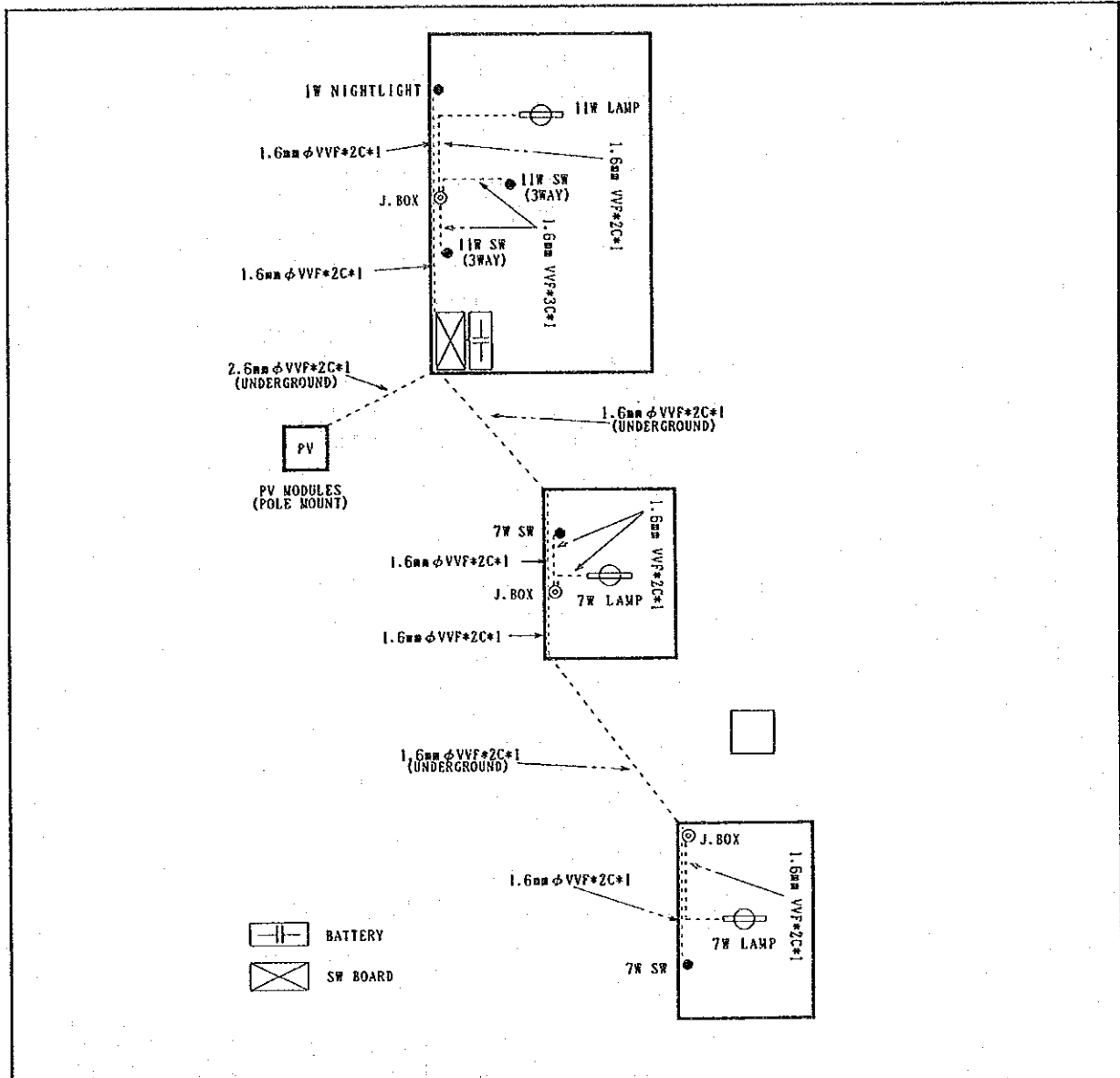

DATE	CHECKER	JUDGEMENT	DATE	CHECKER	JUDGEMENT

5. List of main equipment

No	Equipment Item	Quantity	No	Equipment Item	Quantity
1	PV Module	2 pcs	8	1W LED night light	1 ea
2	Pole Mount	1 set	9	No Fuse Braker(10(A))	1 ea
3	Charge Controller	1 ea	10	Main switch(30(A))	3 ea
4	Battery(12V-100Ah)	1 ea	11	Protection Fuse(15(A))	1 ea
5	Battery Box	1 ea	12	Junction Box	3 pcs
6	Fluorescent Lamp(11w)	1 ea	13	Switch(7(W))	2 pcs
7	Fluorescent Lamp(7w)	2 pcs	14	3Way switch(11(W))	2 pcs

File of PV system Facility for Private House

1. Name of householder : T a b o b o
2. Code NO :
3. Name of village : T a r a t a i
4. Drawing of PV Facility

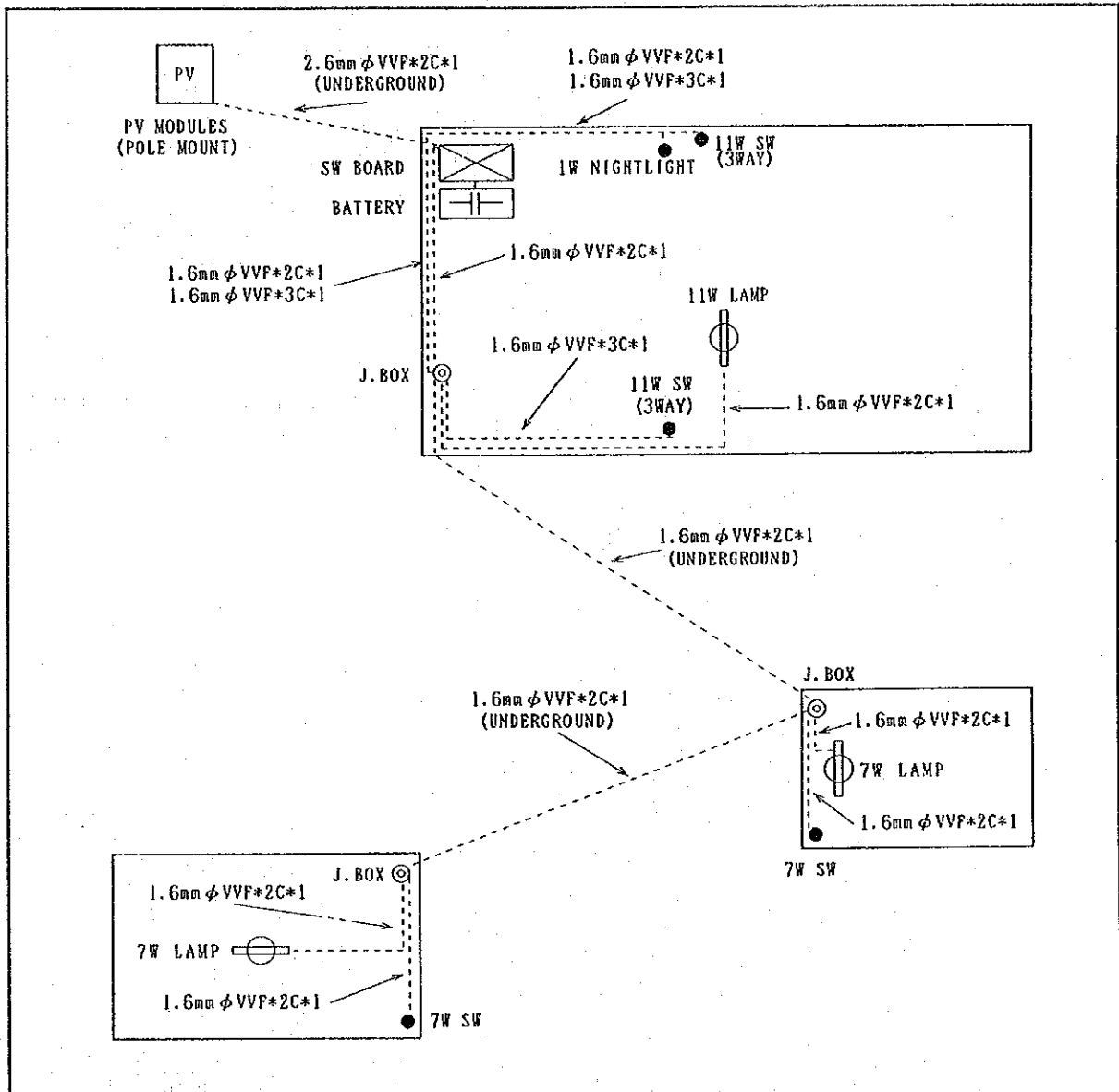

DATE	CHECKER	JUDGEMENT	DATE	CHECKER	JUDGEMENT

5. List of main equipment

	Equipment Item	Quantity		Equipment Item	Quantity
1	PV Module	2 pcs	8	1W LED night light	1 ea
2	Pole Mount	1 set	9	No Fuse Braker(10(A))	1 ea
3	Charge Controller	1 ea	10	Main switch(30(A))	3 ea
4	Battery(12V-100Ah)	1 ea	11	Protection Fuse(15(A))	1 ea
5	Battery Box	1 ea	12	Junction Box	3 pcs
6	Fluorescent Lamp(11w)	1 ea	13	Switch(7(W))	2 pcs
7	Fluorescent Lamp(7w)	2 pcs	14	3Way switch(11(W))	2 pcs

File of PV system Facility for Private House

1. Name of householder : A r e b o n t o
2. Code NO : N 1
3. Name of village : N o t o u e
4. Drawing of PV Facility

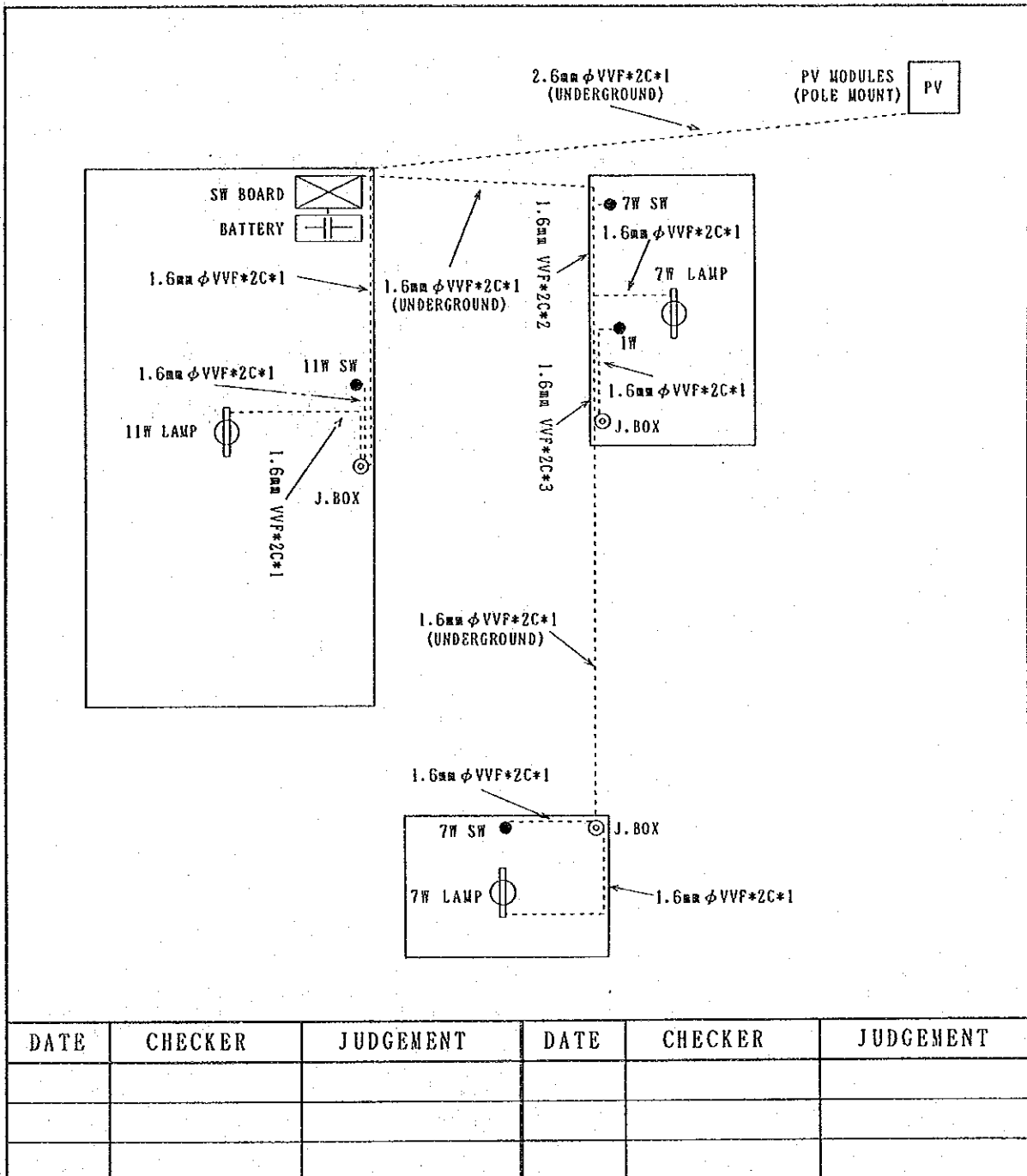

5. List of main equipment

Equipment Item	Quantity	Equipment Item	Quantity
1 PV Module	2 pcs	8 1W LED night light	1 ea
2 Pole Mount	1 set	9 No Fuse Braker(10(A))	1 ea
3 Charge Controller	1 ea	10 Main switch(30(A))	3 ea
4 Battery(12V-100Ah)	1 ea	11 Protection Fuse(15(A))	1 ea
5 Battery Box	1 ea	12 Junction Box	3 pcs
6 Fluorescent Lamp(11w)	1 ea	13 Switch(7(W))	2 pcs
7 Fluorescent Lamp(7w)	2 pcs	14 Switch(11(W))	1 pcs

File of PV system Facility for Private House

1. Name of householder : B e n t a r a
2. Code NO : N 3
3. Name of village : N o t o u e
4. Drawing of PV Facility

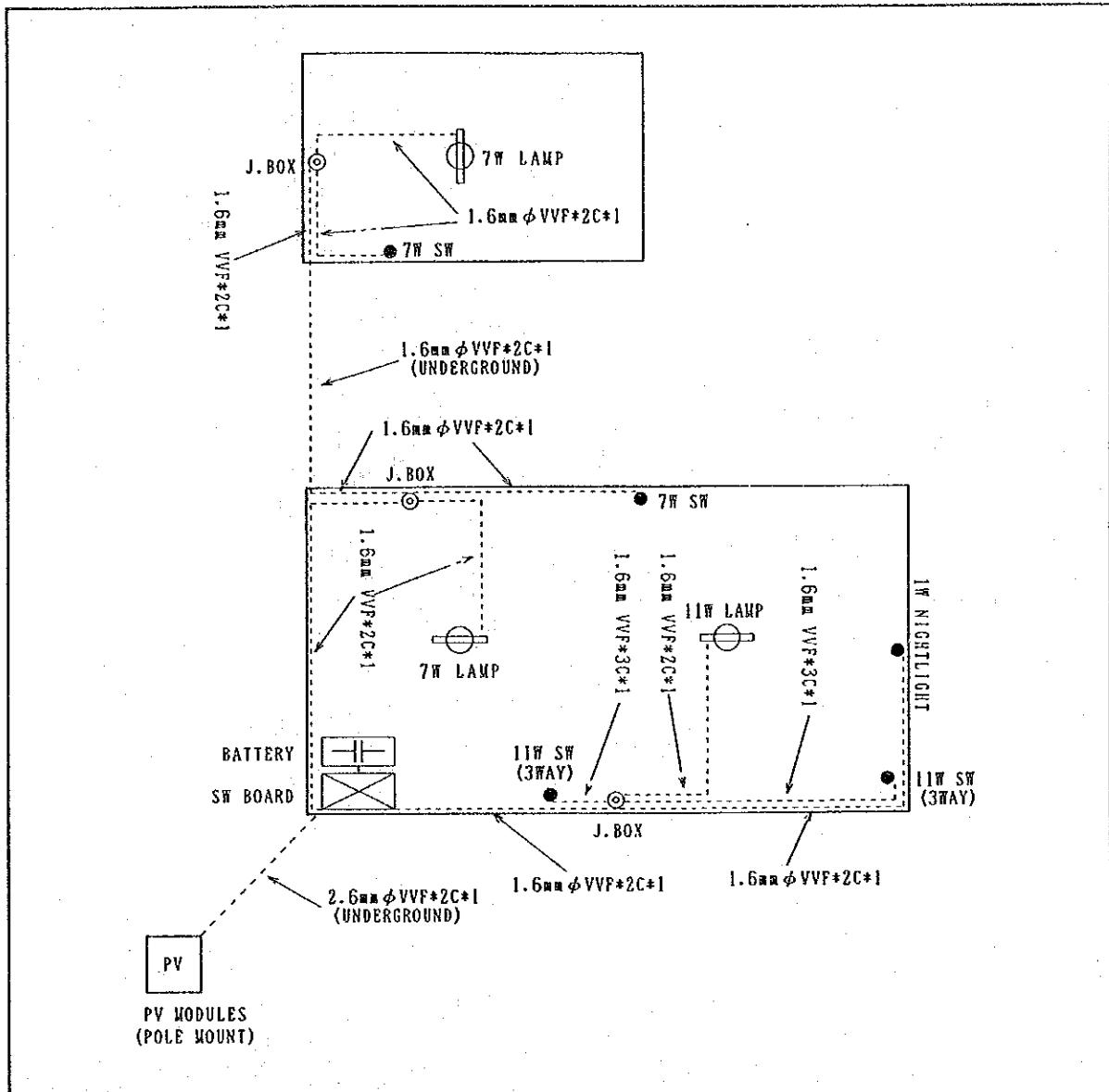

DATE	CHECKER	JUDGEMENT	DATE	CHECKER	JUDGEMENT

5. List of main equipment

No	Equipment Item	Quantity	No	Equipment Item	Quantity
1	PV Module	2 pcs	8	1W LED night light	1 ea
2	Pole Mount	1 set	9	No Fuse Braker(10(A))	1 ea
3	Charge Controller	1 ea	10	Main switch(30(A))	3 ea
4	Battery(12V-100Ah)	1 ea	11	Protection Fuse(15(A))	1 ea
5	Battery Box	1 ea	12	Junction Box	3 pcs
6	Fluorescent Lamp(11w)	1 ea	13	Switch(7(W))	2 pcs
7	Fluorescent Lamp(7w)	2 pcs	14	3way switch(11(W))	2 pcs

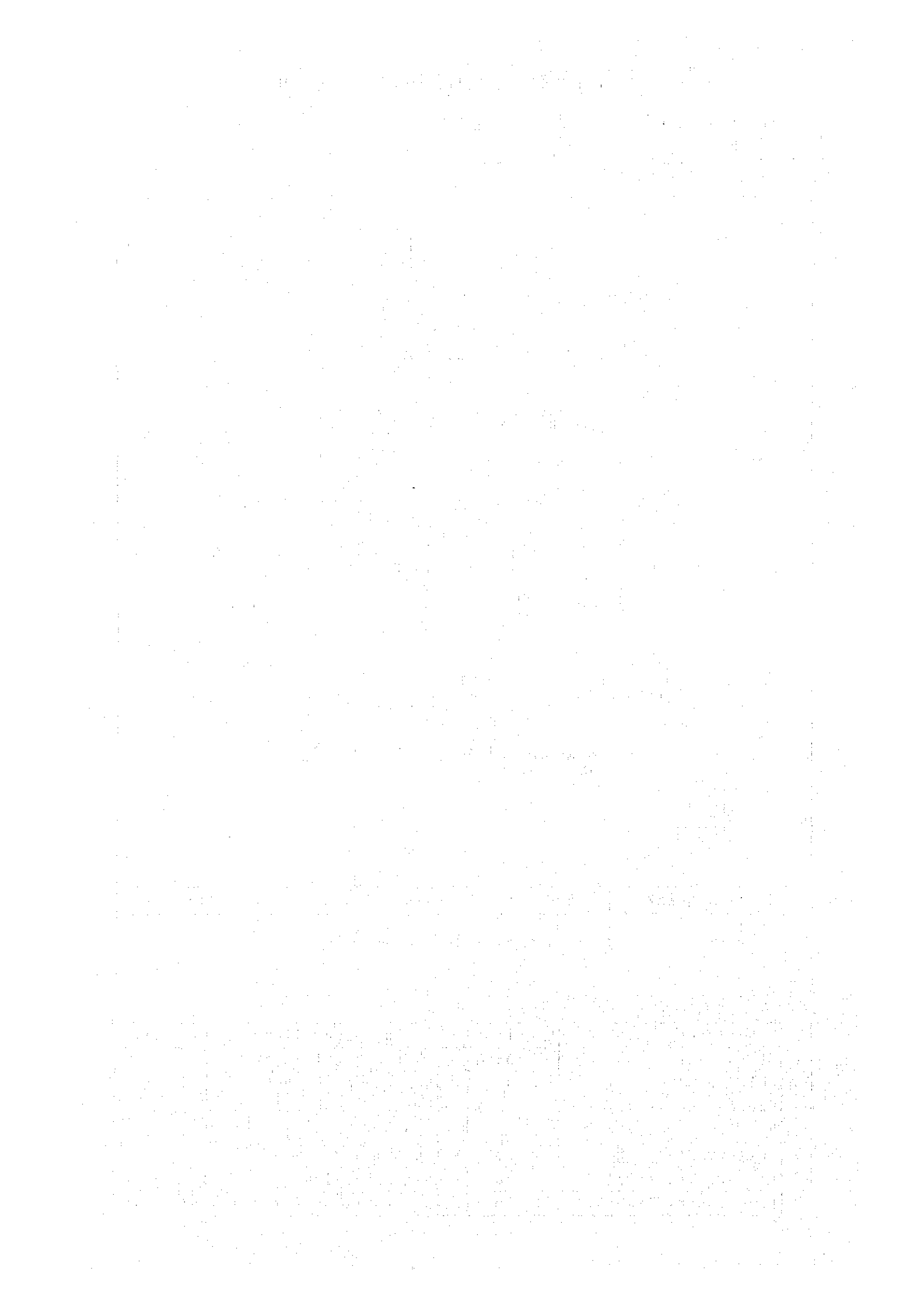

File of PV system Facility for Private House

1. Name of householder : T e r i n a k i
2. Code NO : N 3 0
3. Name of village : N o t o u e
4. Drawing of PV Facility

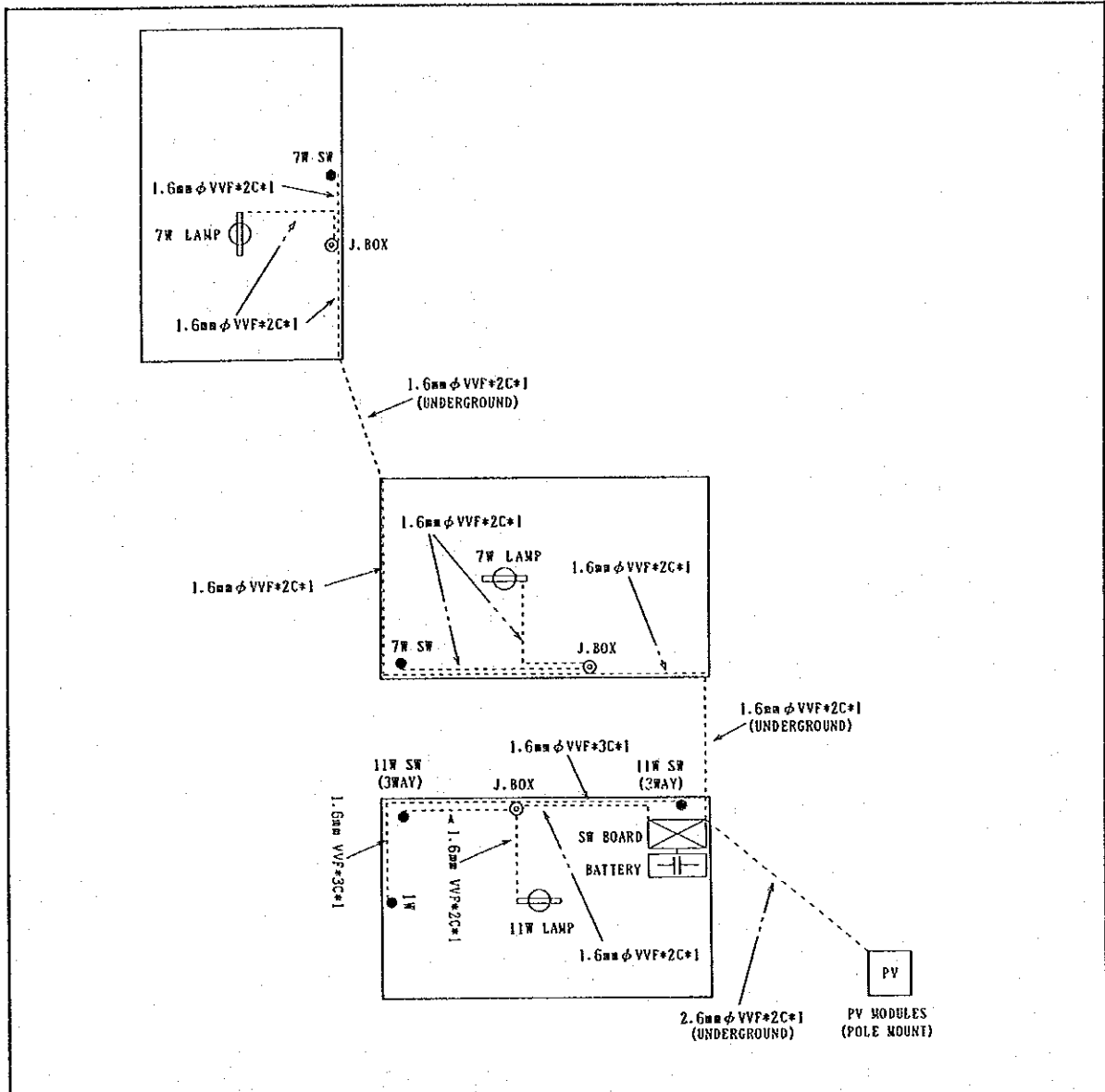

DATE	CHECKER	JUDGEMENT	DATE	CHECKER	JUDGEMENT

5. List of main equipment

No.	Equipment Item	Quantity	No.	Equipment Item	Quantity
1	PV Module	2 pcs	8	1W LED night light	1 ea
2	Pole Mount	1 set	9	No Fuse Braker(10(A))	1 ea
3	Charge Controller	1 ea	10	Main switch(30(A))	3 ea
4	Battery(12V-100Ah)	1 ea	11	Protection Fuse(15(A))	1 ea
5	Battery Box	1 ea	12	Junction Box	3 pcs
6	Fluorescent Lamp(11w)	1 ea	13	Switch(7(W))	2 pcs
7	Fluorescent Lamp(7w)	2 pcs	14	3way switch(11(W))	2 pcs

File of PV system Facility for Private House

1. Name of householder : U t i m a w a
2. Code NO : N 3 5
3. Name of village : N o t o u e
4. Drawing of PV Facility

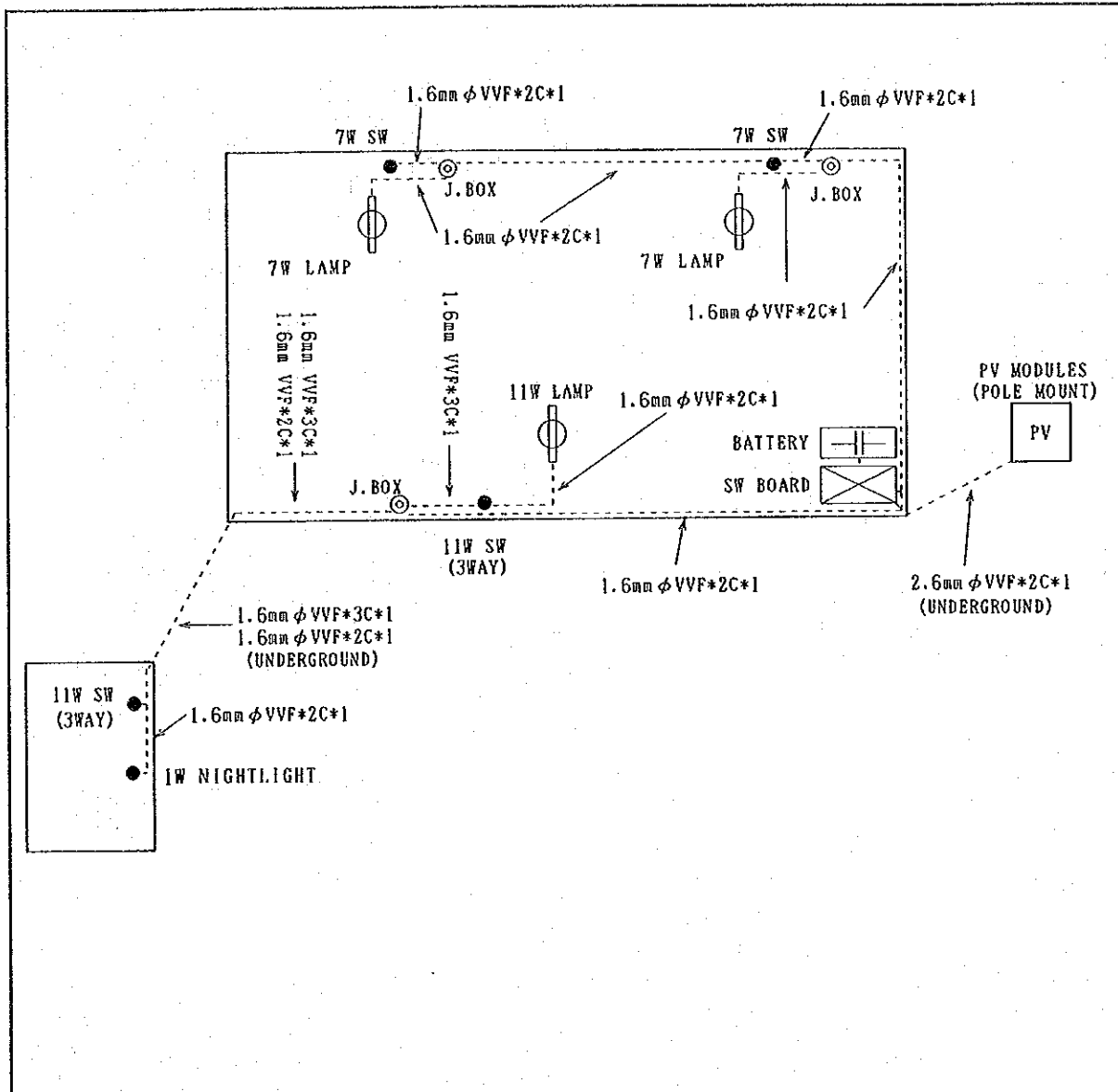

DATE	CHECKER	JUDGEMENT	DATE	CHECKER	JUDGEMENT

5. List of main equipment

No	Equipment Item	Quantity	No	Equipment Item	Quantity
1	PV Module	2 pcs	8	1W LED night light	1 ea
2	Pole Mount	1 set	9	No Fuse Braker(10(A))	1 ea
3	Charge Controller	1 ea	10	Main switch(30(A))	3 ea
4	Battery(12V-100Ah)	1 ea	11	Protection Fuse(15(A))	1 ea
5	Battery Box	1 ea	12	Junction Box	3 pcs
6	Fluorescent Lamp(11w)	1 ea	13	Switch(7(W))	2 pcs
7	Fluorescent Lamp(7w)	2 pcs	14	3Way switch(11(W))	2 pcs

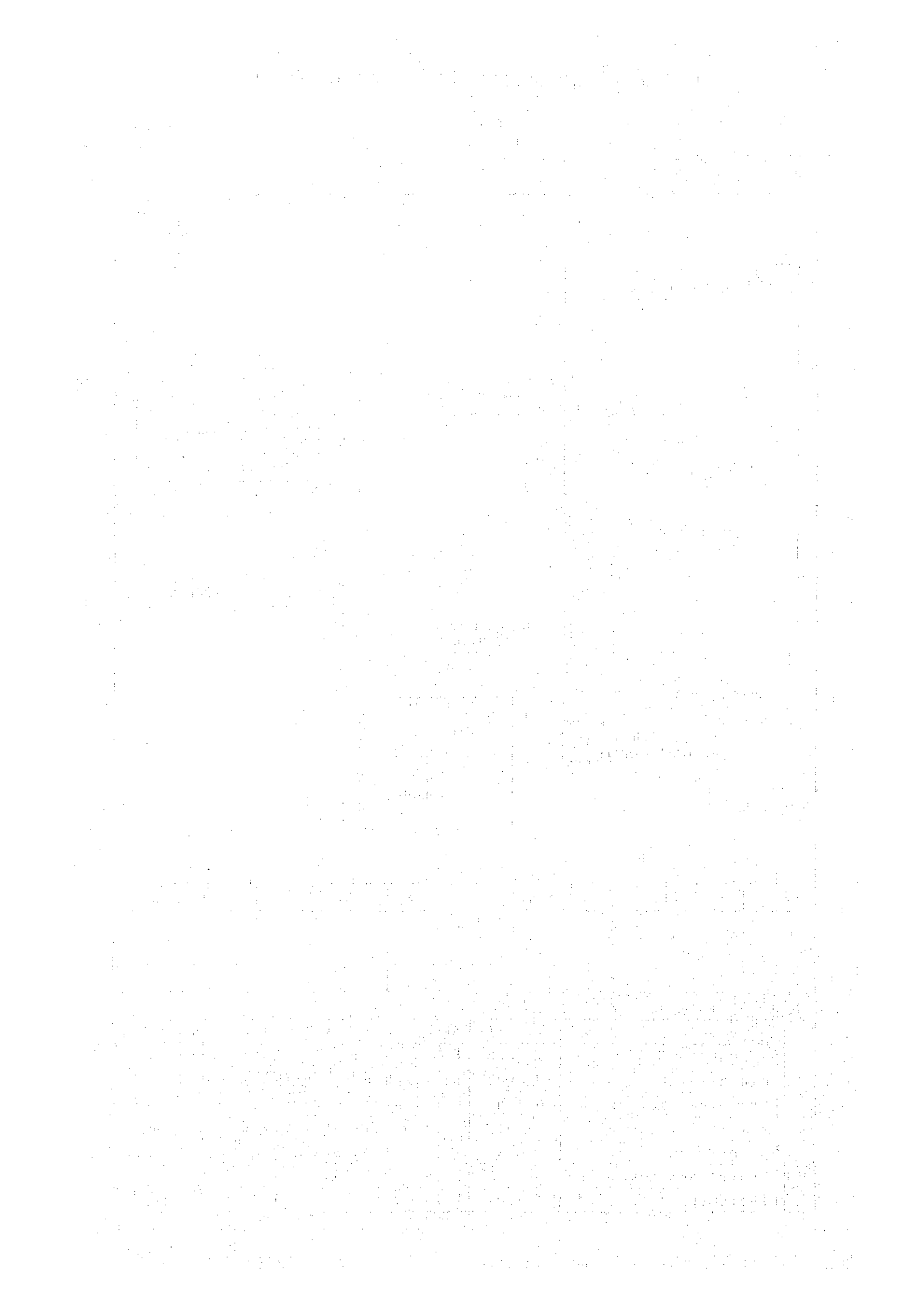

File of PV system Facility for Private House

1. Name of householder : I o t e b w a
2. Code NO : N 3 7
3. Name of village : N o t o u e
4. Drawing of PV Facility

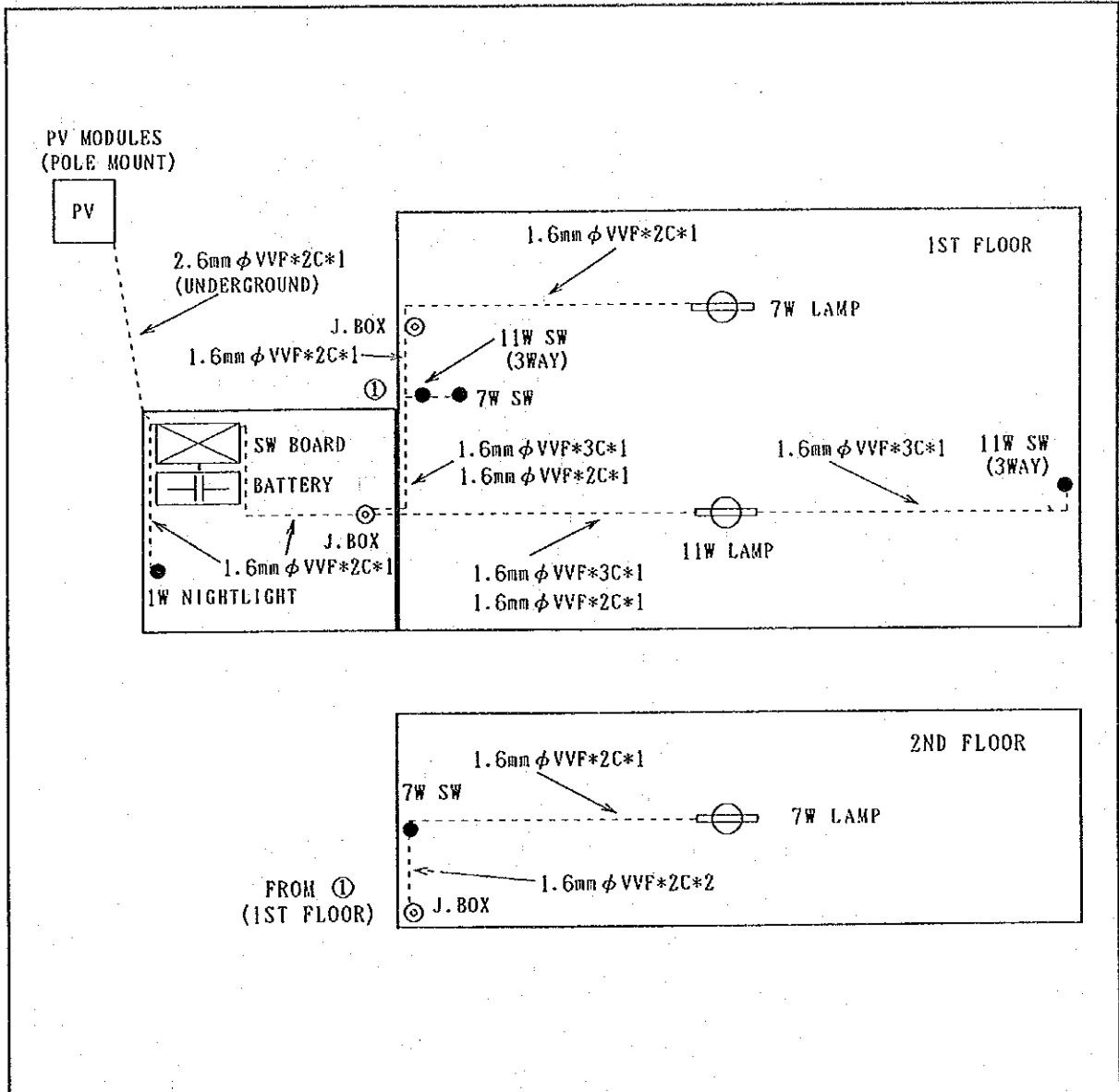

DATE	CHECKER	JUDGEMENT	DATE	CHECKER	JUDGEMENT

5. List of main equipment

No	Equipment Item	Quantity	No	Equipment Item	Quantity
1	PV Module	2 pcs	8	1W LED night light	1 ea
2	Pole Mount	1 set	9	No Fuse Braker(10(A))	1 ea
3	Charge Controller	1 ea	10	Main switch(30(A))	3 ea
4	Battery(12V-100Ah)	1 ea	11	Protection Fuse(15(A))	1 ea
5	Battery Box	1 ea	12	Junction Box	3 pcs
6	Fluorescent Lamp(11w)	1 ea	13	Switch(7(W))	2 pcs
7	Fluorescent Lamp(7w)	2 pcs	14	3Way switch(11(W))	2 pcs

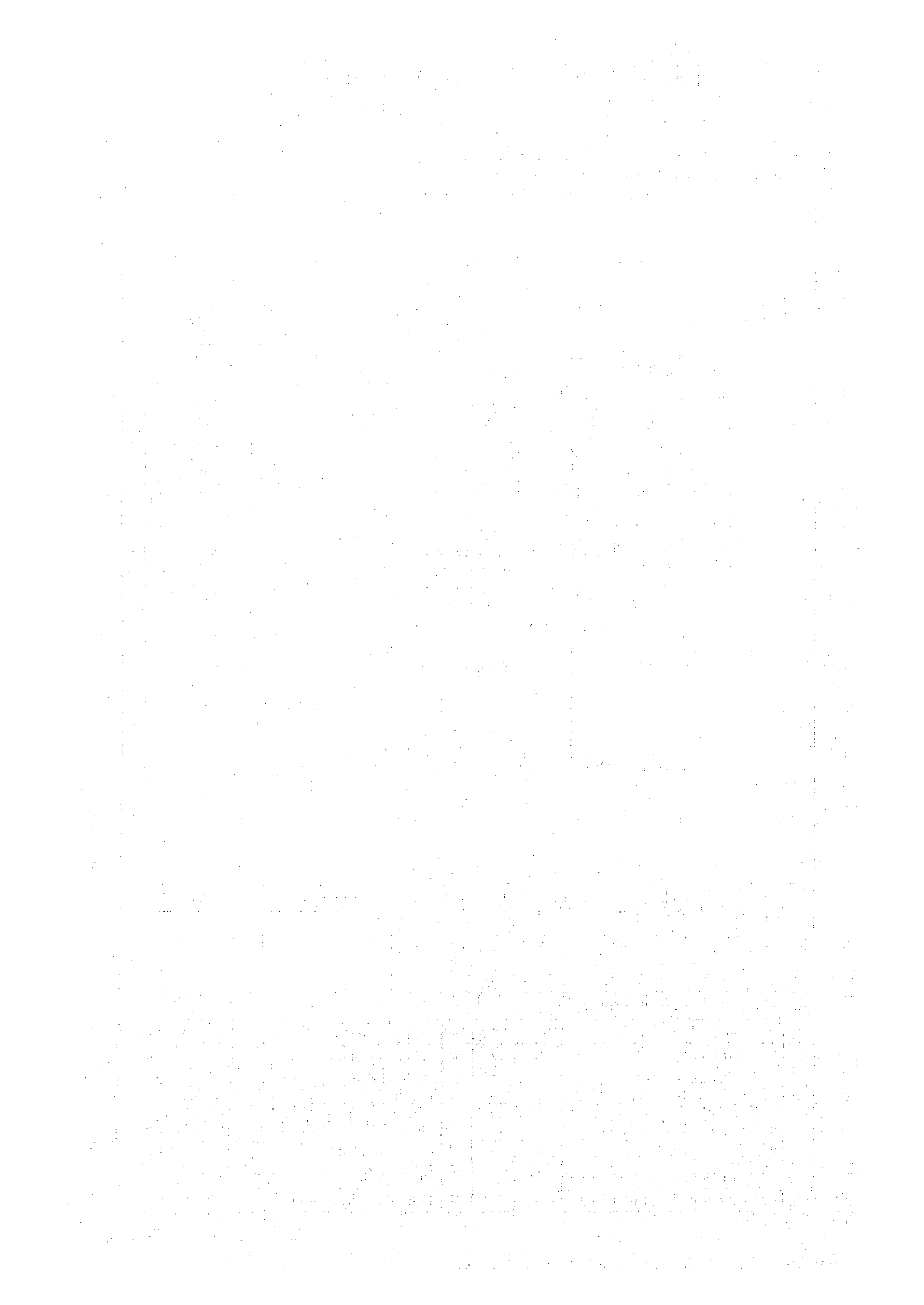

File of PV system Facility for Private House

1. Name of householder : A i r i n
2. Code NO : N 3 8
3. Name of village : N o t o u e
4. Drawing of PV Facility

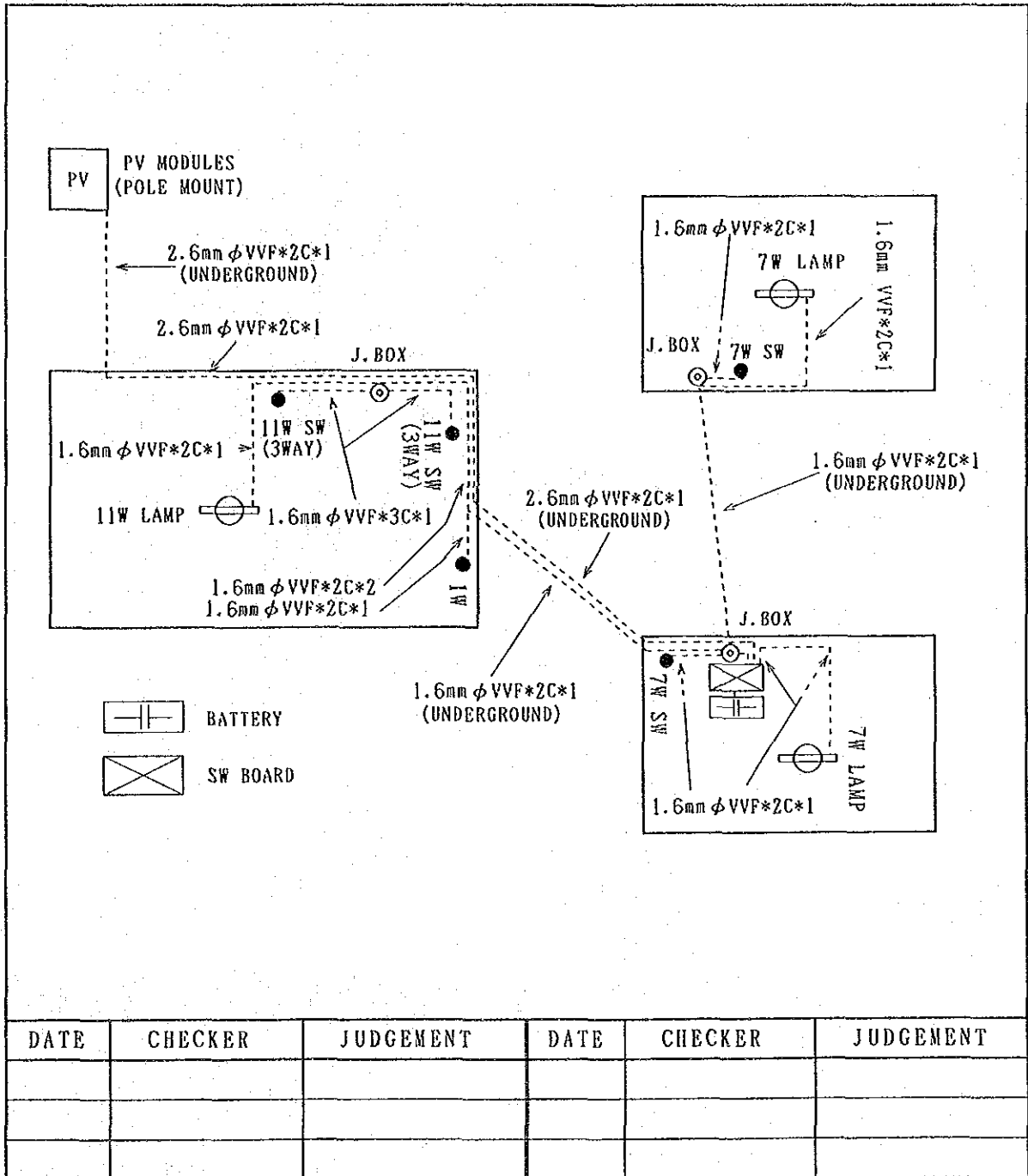

5. List of main equipment

Equipment Item	Quantity	Equipment Item	Quantity
1 PV Module	2 pcs	8 1W LED night light	1 ea
2 Pole Mount	1 set	9 No Fuse Braker(10(A))	1 ea
3 Charge Controller	1 ea	10 Main switch(30(A))	3 ea
4 Battery(12V-100Ah)	1 ea	11 Protection Fuse(15(A))	1 ea
5 Battery Box	1 ea	12 Junction Box	3 pcs
6 Fluorescent Lamp(11w)	1 ea	13 Switch(7(W))	2 pcs
7 Fluorescent Lamp(7w)	2 pcs	14 3Way switch(11(W))	2 pcs

File of PV system Facility for Private House

1. Name of householder : Roni Ili Tetabo
2. Code NO :
3. Name of village : Notoue
4. Drawing of PV Facility

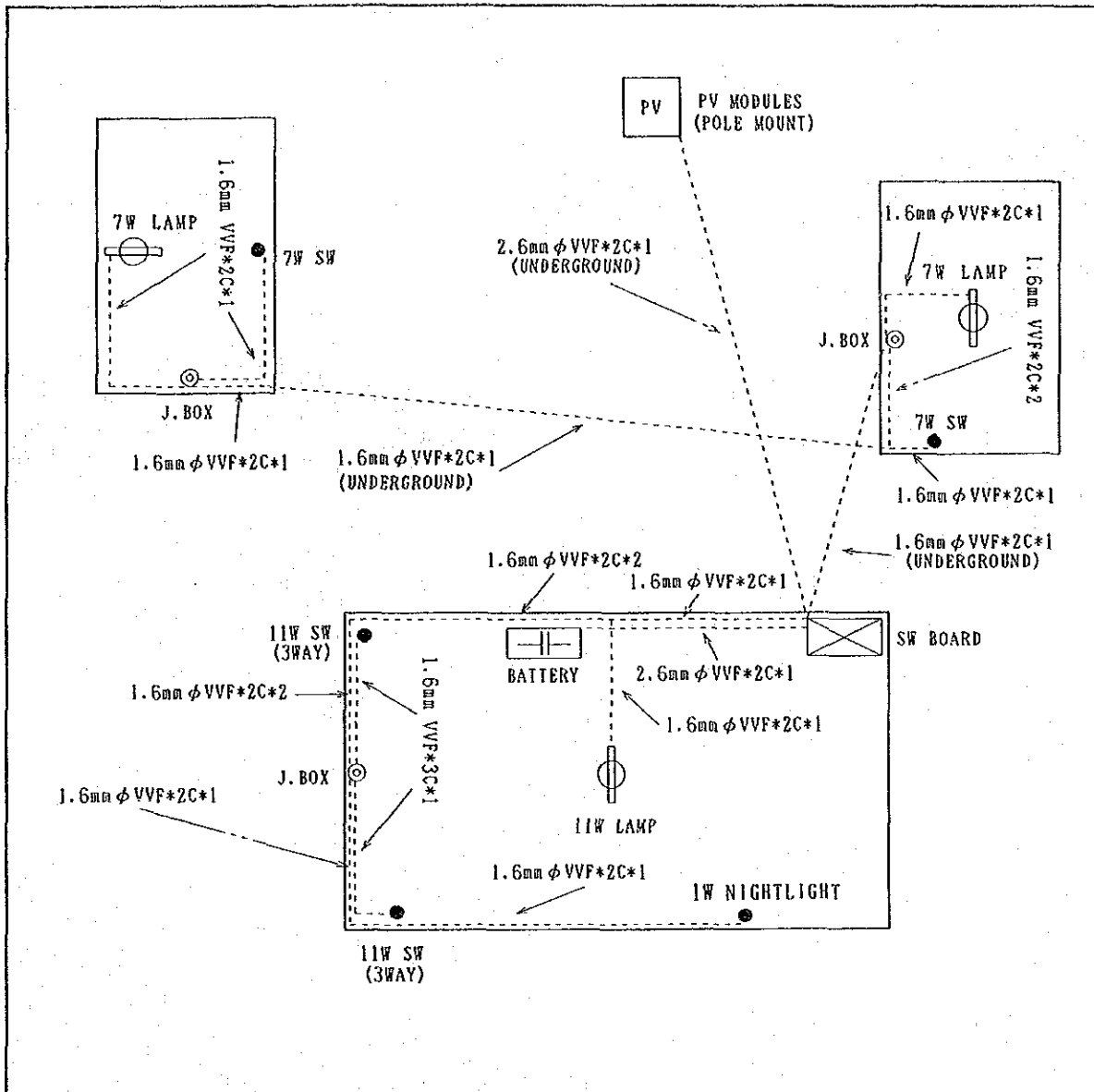

DATE	CHECKER	JUDGEMENT	DATE	CHECKER	JUDGEMENT

5. List of main equipment

	Equipment Item	Quantity		Equipment Item	Quantity
1	PV Module	2 pcs	8	1W LED night light	1 ea
2	Pole Mount	1 set	9	No Fuse Braker(10(A))	1 ea
3	Charge Controller	1 ea	10	Main switch(30(A))	3 ea
4	Battery(12V-100Ah)	1 ea	11	Protection Fuse(15(A))	1 ea
5	Battery Box	1 ea	12	Junction Box	3 pcs
6	Fluorescent Lamp(11w)	1 ea	13	Switch(7(W))	2 pcs
7	Fluorescent Lamp(7w)	2 pcs	14	3Way switch(11(W))	2 pcs

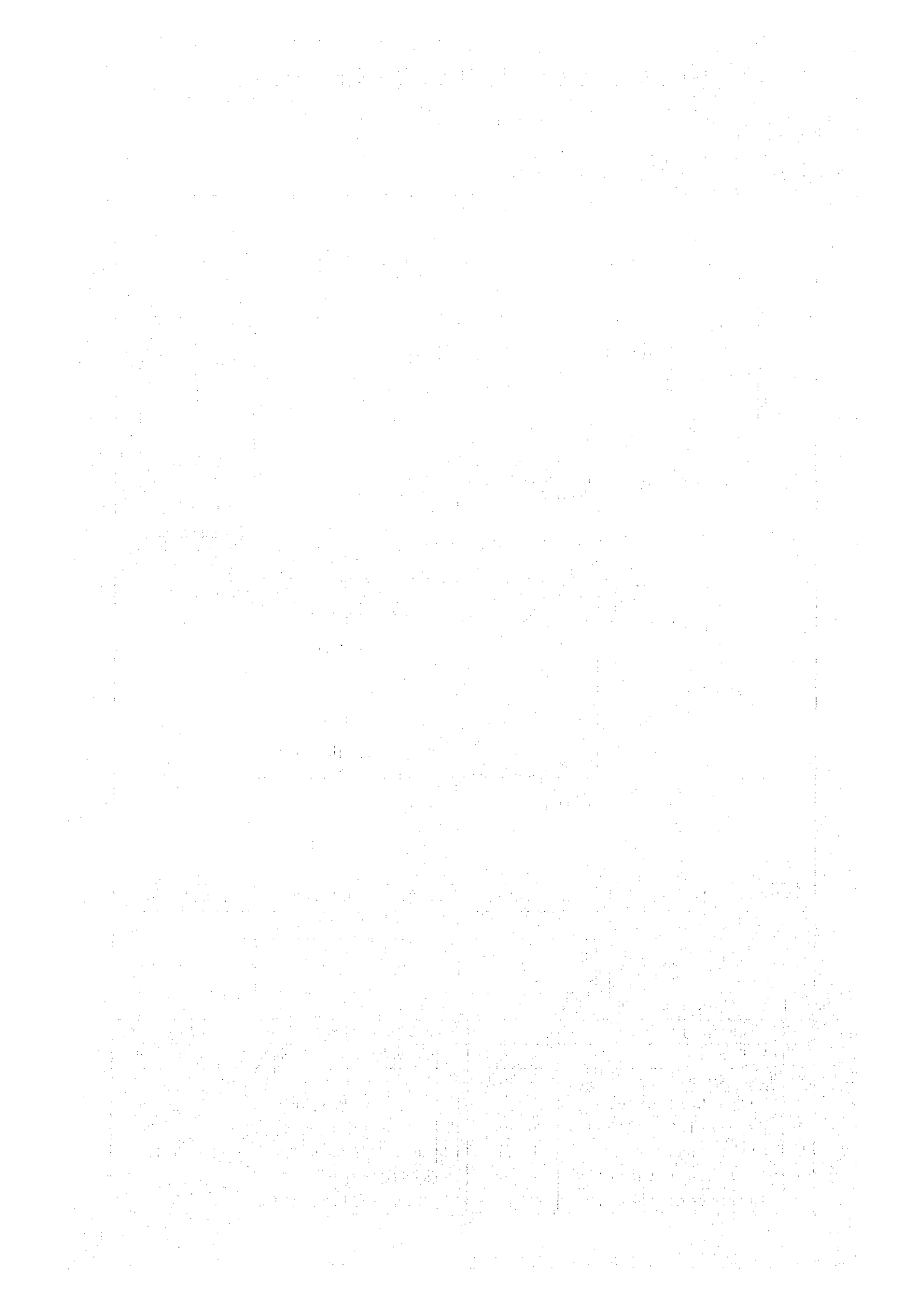

File of PV system Facility for Private House

1. Name of householder : T a u k a b a n I o a n e
2. Code NO :
3. Name of village : N o t o u e
4. Drawing of PV Facility

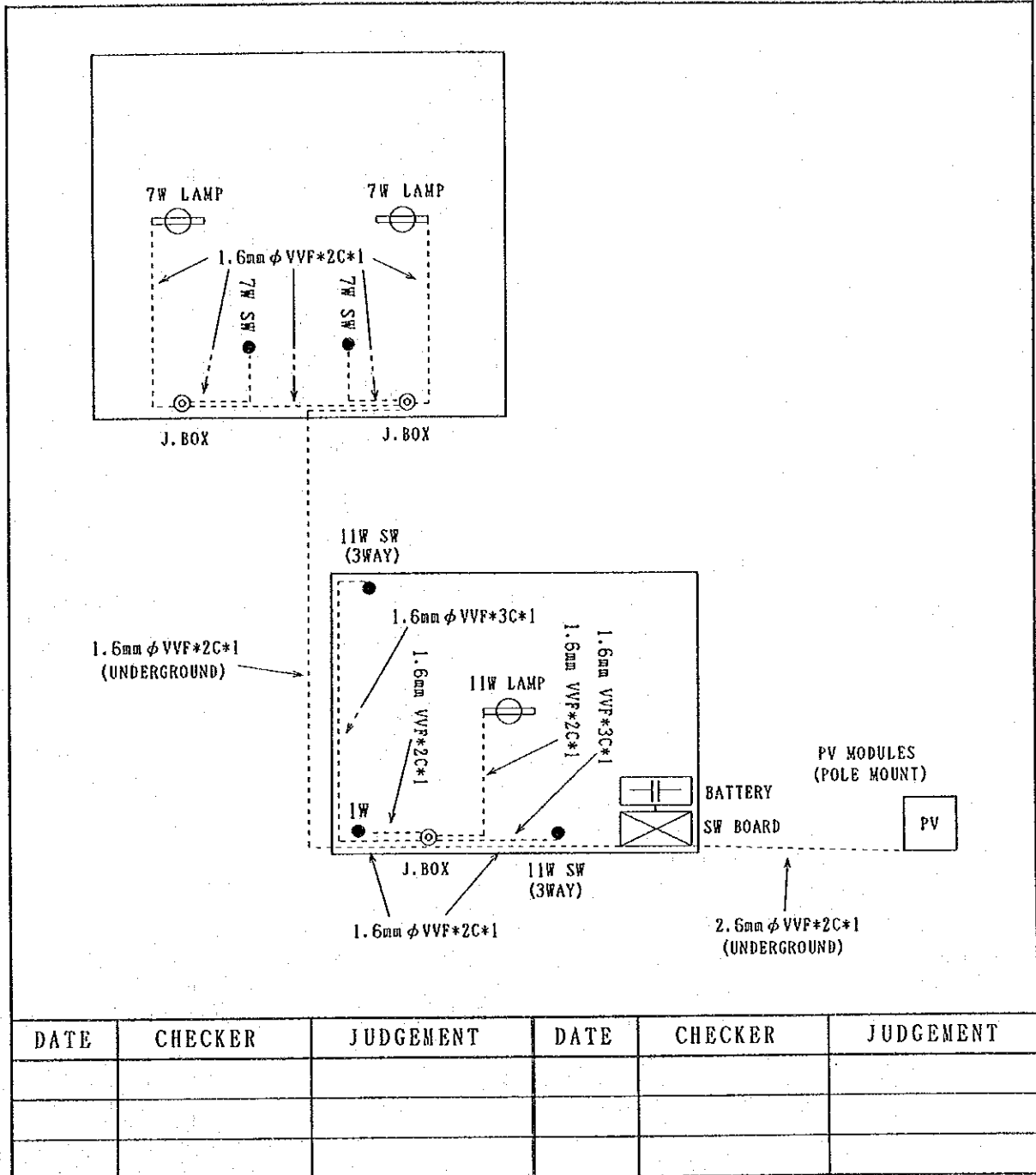

5. List of main equipment

Equipment Item	Quantity	Equipment Item	Quantity
1 PV Module	2 pcs	8 1W LED night light	1 ea
2 Pole Mount	1 set	9 No Fuse Braker(10(A))	1 ea
3 Charge Controller	1 ea	10 Main switch(30(A))	3 ea
4 Battery(12V-100Ah)	1 ea	11 Protection Fuse(15(A))	1 ea
5 Battery Box	1 ea	12 Junction Box	3 pcs
6 Fluorescent Lamp(11w)	1 ea	13 Switch(7(W))	2 pcs
7 Fluorescent Lamp(7w)	2 pcs	14 3Way switch(11(W))	2 pcs

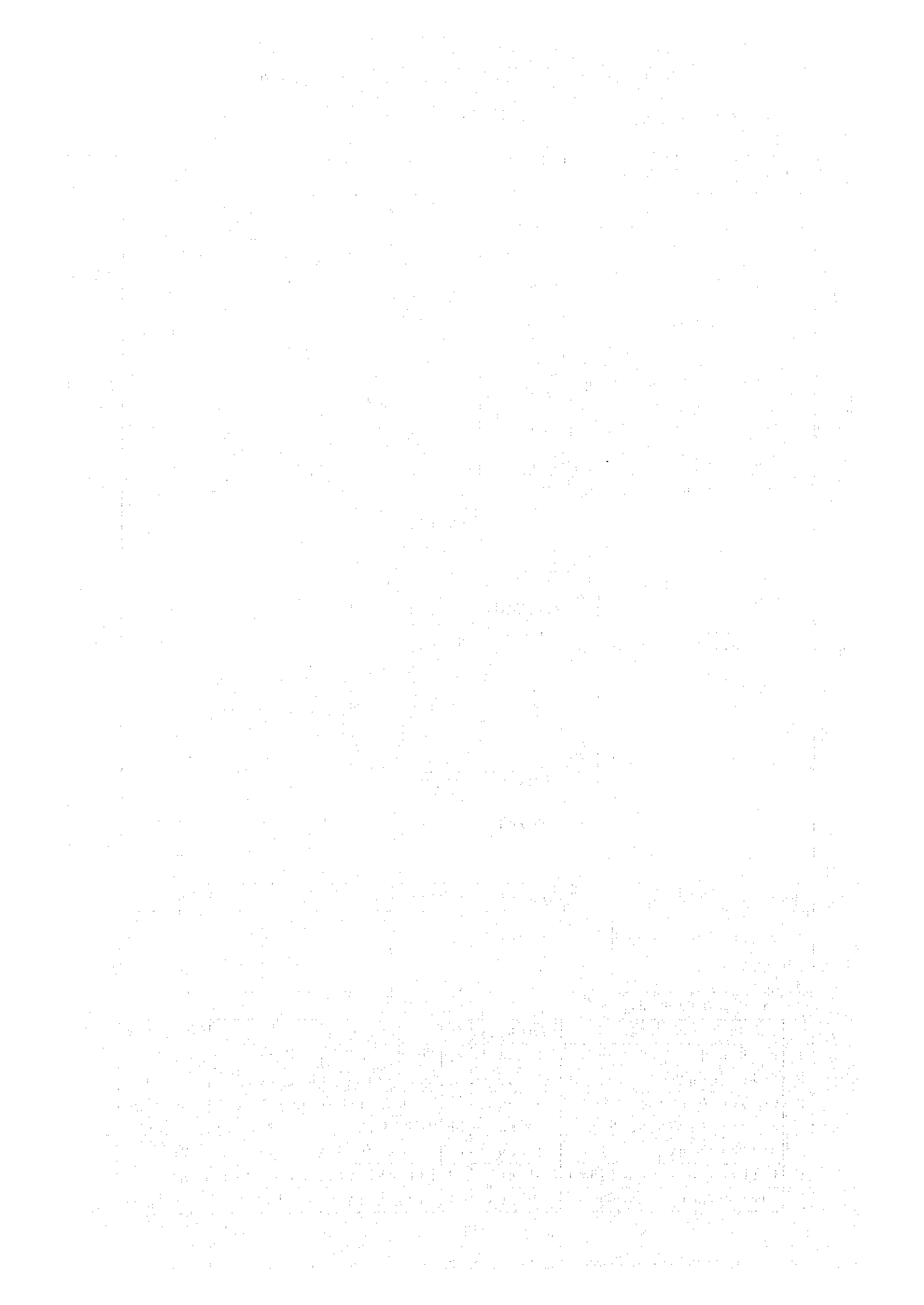

File of PV system Facility for Private House

1. Name of householder : Tamuera Karebanga
2. Code NO :
3. Name of village : Notoue
4. Drawing of PV Facility

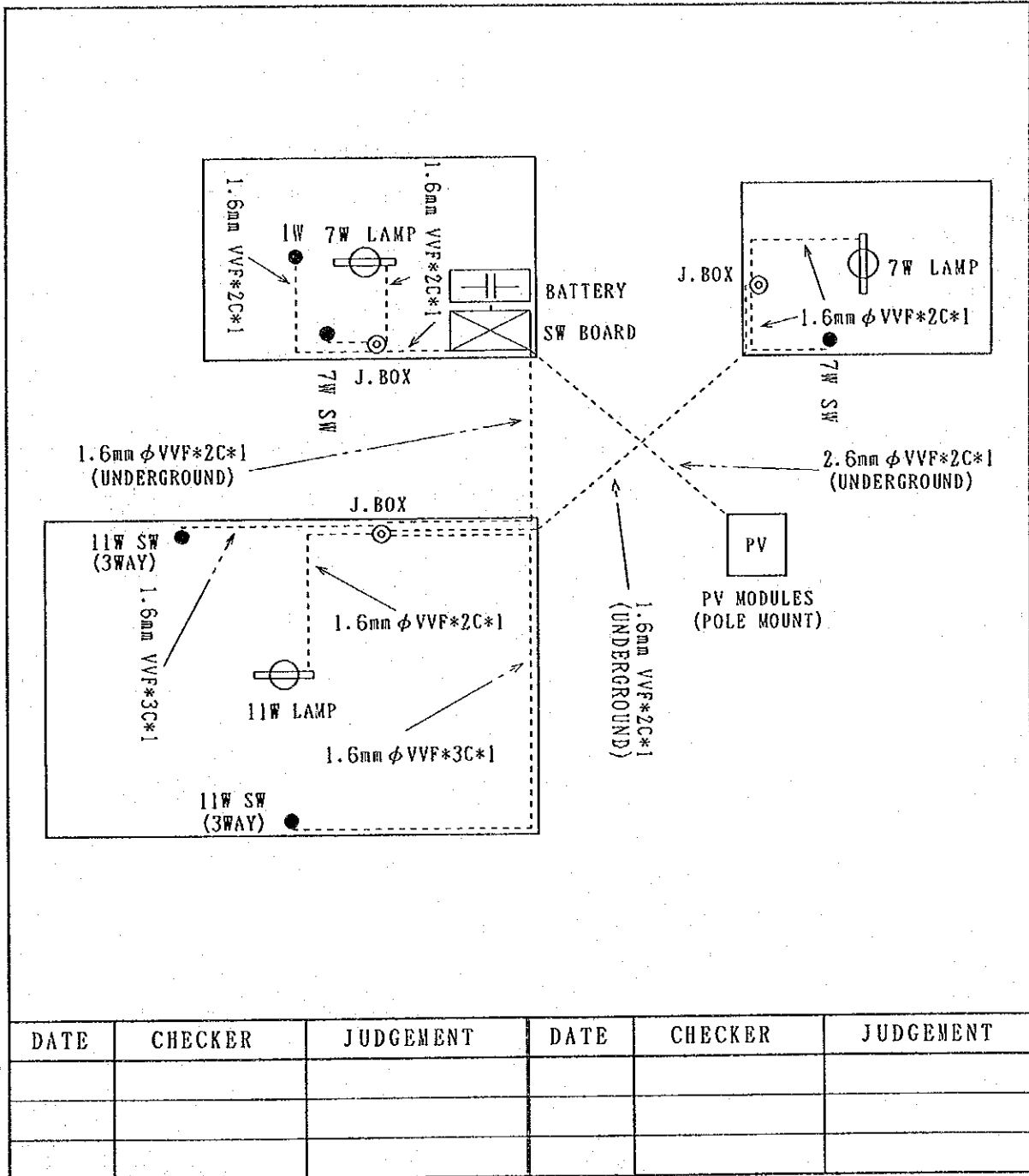

DATE	CHECKER	JUDGEMENT	DATE	CHECKER	JUDGEMENT

5. List of main equipment

No	Equipment Item	Quantity	No	Equipment Item	Quantity
1	PV Module	2 pcs	8	1W LED night light	1 ea
2	Pole Mount	1 set	9	No Fuse Braker(10(A))	1 ea
3	Charge Controller	1 ea	10	Main switch(30(A))	3 ea
4	Battery(12V-100Ah)	1 ea	11	Protection Fuse(15(A))	1 ea
5	Battery Box	1 ea	12	Junction Box	3 pcs
6	Fluorescent Lamp(11w)	1 ea	13	Switch(7(W))	2 pcs
7	Fluorescent Lamp(7w)	2 pcs	14	3Way switch(11(W))	2 pcs

File of PV system Facility for Private House

1. Name of householder : Teb i k e N e n e i a
2. Code NO :
3. Name of village : N o t o u e
4. Drawing of PV Facility

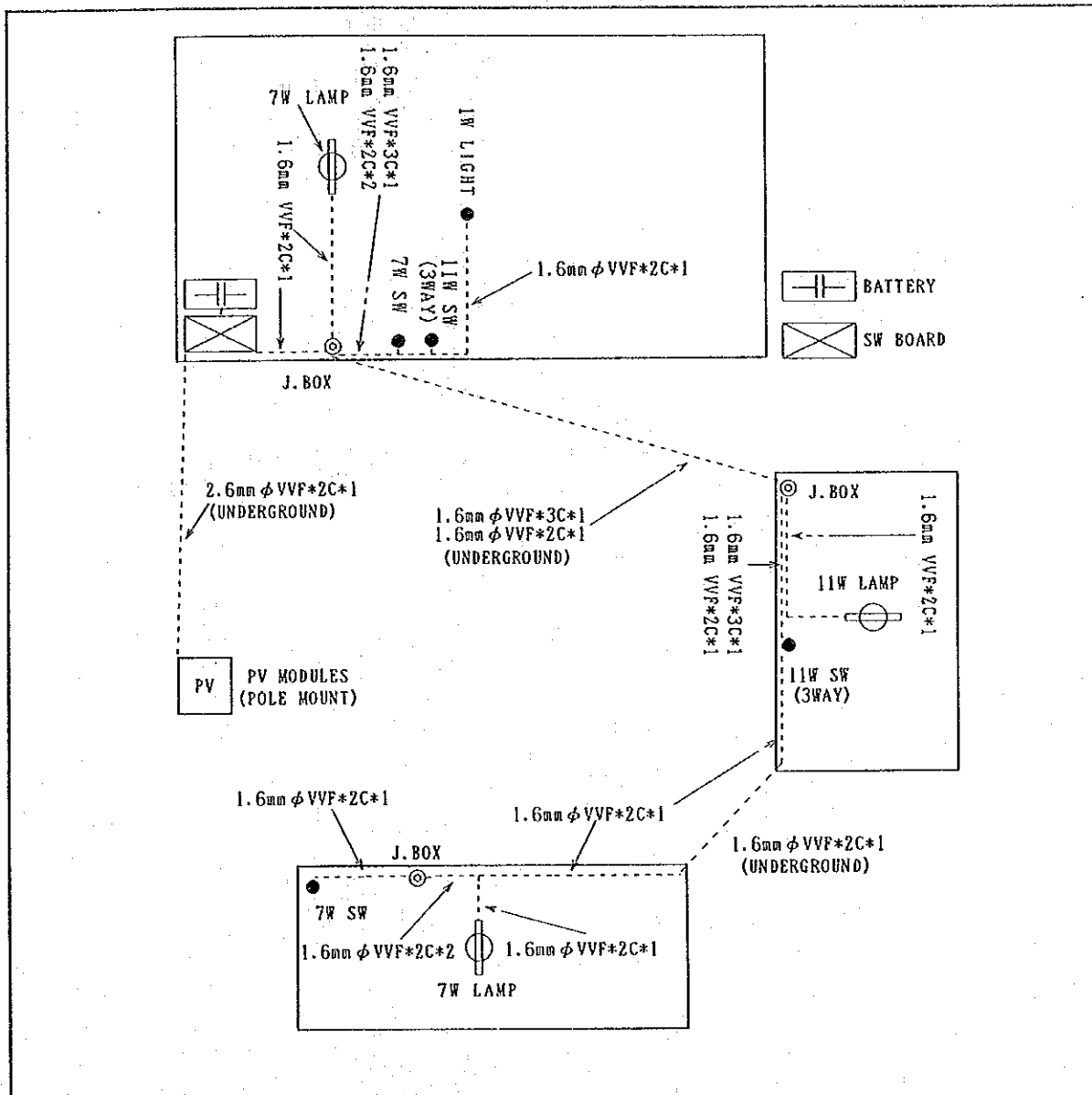

DATE	CHECKER	JUDGEMENT	DATE	CHECKER	JUDGEMENT

5. List of main equipment

No	Equipment Item	Quantity	No	Equipment Item	Quantity
1	PV Module	2 pcs	8	1W LED night light	1 ea
2	Pole Mount	1 set	9	No Fuse Braker(10(A))	1 ea
3	Charge Controller	1 ea	10	Main switch(30(A))	3 ea
4	Battery(12V-100Ah)	1 ea	11	Protection Fuse(15(A))	1 ea
5	Battery Box	1 ea	12	Junction Box	3 pcs
6	Fluorescent Lamp(11w)	1 ea	13	Switch(7(W))	2 pcs
7	Fluorescent Lamp(7w)	2 pcs	14	3Way switch(11(W))	2 pcs

File of PV system Facility for Private House

1. Name of householder : T i i b a u
2. Code NO :
3. Name of village : N o t o u e
4. Drawing of PV Facility

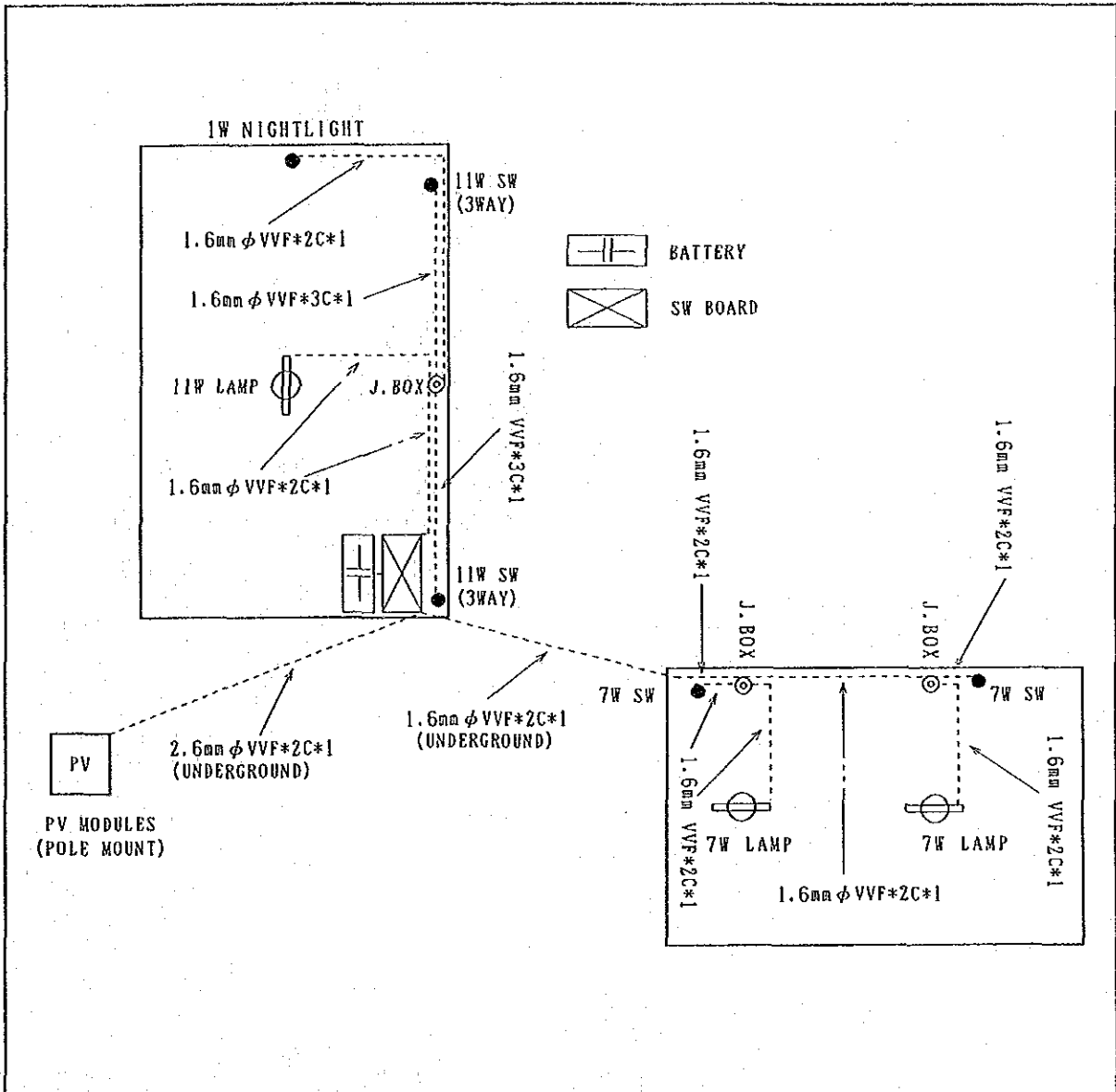

DATE	CHECKER	JUDGEMENT	DATE	CHECKER	JUDGEMENT

5. List of main equipment

No	Equipment Item	Quantity	No	Equipment Item	Quantity
1	PV Module	2 pcs	8	1W LED night light	1 ea
2	Pole Mount	1 set	9	No Fuse Braker(10(A))	1 ea
3	Charge Controller	1 ea	10	Main switch(30(A))	3 ea
4	Battery(12V-100Ah)	1 ea	11	Protection Fuse(15(A))	1 ea
5	Battery Box	1 ea	12	Junction Box	3 pcs
6	Fluorescent Lamp(11w)	1 ea	13	Switch(7(W))	2 pcs
7	Fluorescent Lamp(7w)	2 pcs	14	3way switch(11(W))	2 pcs

File of PV system Facility for Private House

1. Name of householder : A b a k u k a
2. Code NO : A 1
3. Name of village : A b a o k o r o
4. Drawing of PV Facility

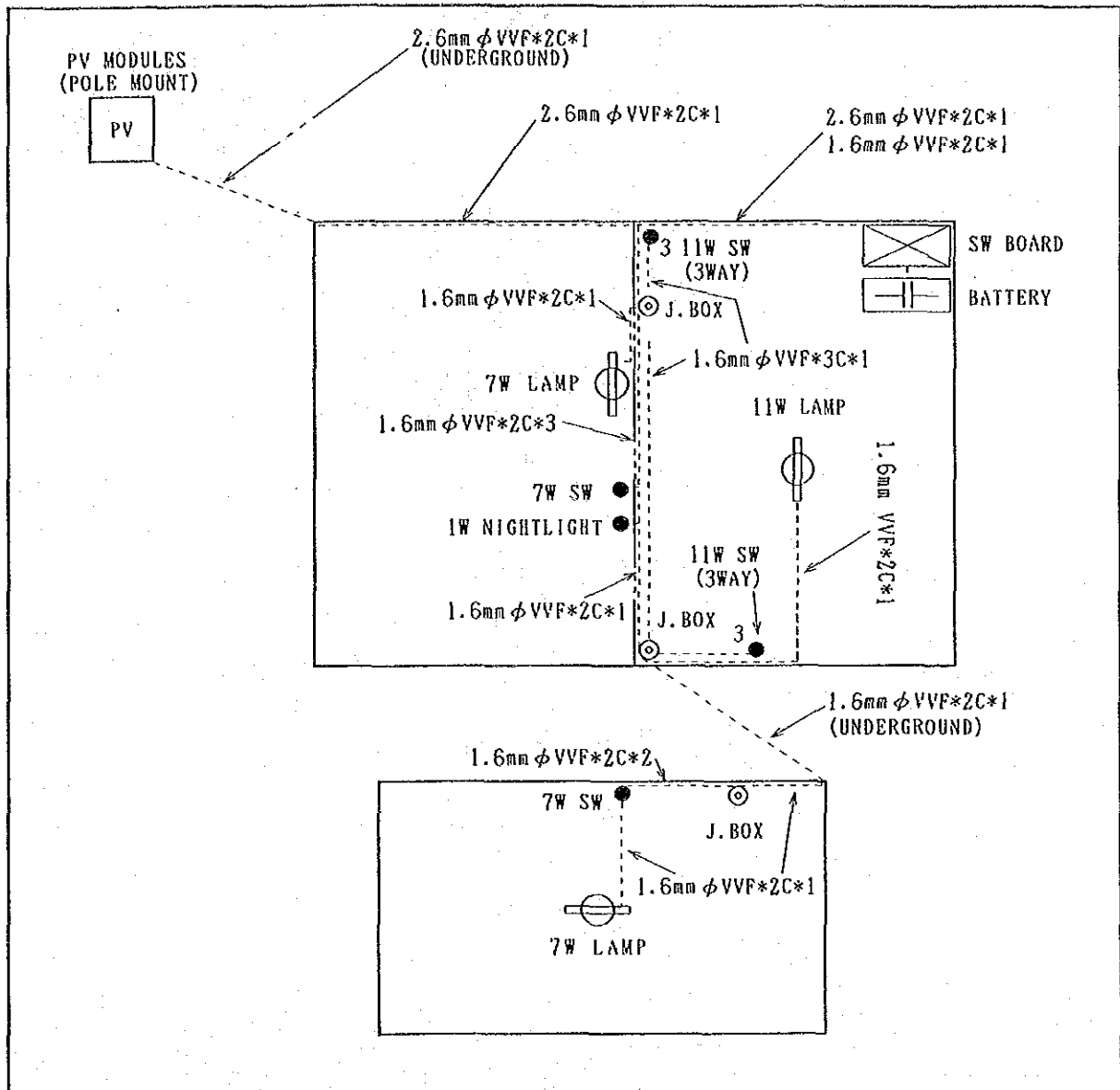

DATE	CHECKER	JUDGEMENT	DATE	CHECKER	JUDGEMENT

5. List of main equipment

No	Equipment Item	Quantity	No	Equipment Item	Quantity
1	PV Module	2 pcs	8	1W LED night light	1 ea
2	Pole Mount	1 set	9	No Fuse Braker(10(A))	1 ea
3	Charge Controller	1 ea	10	Main switch(30(A))	3 ea
4	Battery(12V-100Ah)	1 ea	11	Protection Fuse(15(A))	1 ea
5	Battery Box	1 ea	12	Junction Box	3 pcs
6	Fluorescent Lamp(11w)	1 ea	13	Switch(7(W))	2 pcs
7	Fluorescent Lamp(7w)	2 pcs	14	3Way switch(11(W))	2 pcs

File of PV system Facility for Private House

1. Name of householder : B e i a T o a r a
2. Code NO : A 4
3. Name of village : A b a o k o r o
4. Drawing of PV Facility

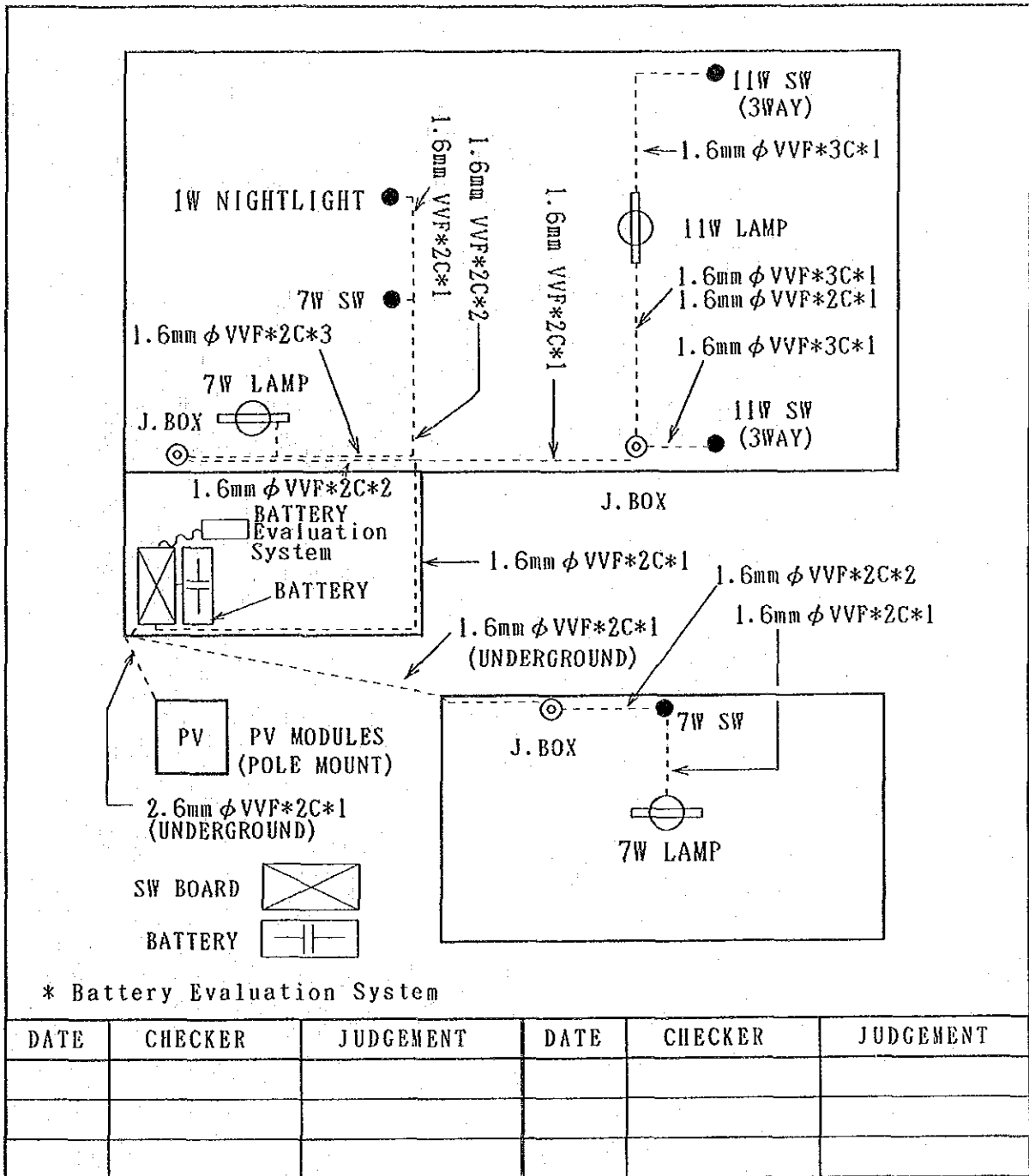

5. List of main equipment

Equipment Item	Quantity	Equipment Item	Quantity
1 PV Module	2 pcs	8 1W LED night light	1 ea
2 Pole Mount	1 set	9 No Fuse Braker(10(A))	1 ea
3 Charge Controller	1 ea	10 Main switch(30(A))	3 ea
4 Battery(12V-100Ah)	1 ea	11 Protection Fuse(15(A))	1 ea
5 Battery Box	1 ea	12 Junction Box	3 pcs
6 Fluorescent Lamp(11w)	1 ea	13 Switch(7(W))	2 pcs
7 Fluorescent Lamp(7w)	2 pcs	14 3Way switch(11(W))	2 pcs

File of PV system Facility for Private House

1. Name of householder : E k e i e t a I t i t a a k e
2. Code NO : A 5
3. Name of village : A b a o k o r o
4. Drawing of PV Facility

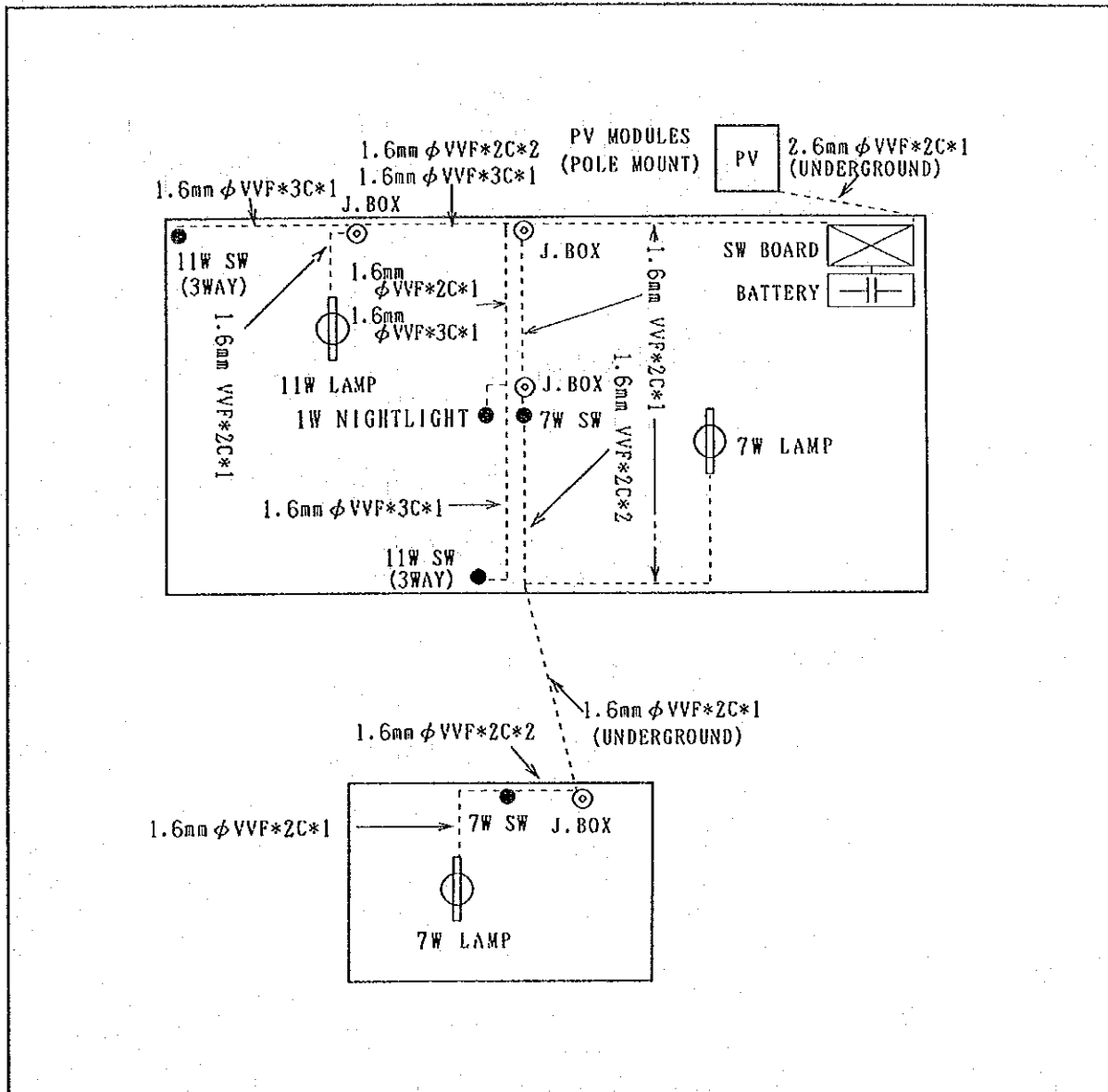

DATE	CHECKER	JUDGEMENT	DATE	CHECKER	JUDGEMENT

5. List of main equipment

Equipment Item	Quantity	Equipment Item	Quantity
1 PV Module	2 pcs	8 1W LED night light	1 ea
2 Pole Mount	1 set	9 No Fuse Braker(10(A))	1 ea
3 Charge Controller	1 ea	10 Main switch(30(A))	3 ea
4 Battery(12V-100Ah)	1 ea	11 Protection Fuse(15(A))	1 ea
5 Battery Box	1 ea	12 Junction Box	3 pcs
6 Fluorescent Lamp(11w)	1 ea	13 Switch(7(W))	2 pcs
7 Fluorescent Lamp(7w)	2 pcs	14 3Way switch(11(W))	2 pcs

File of PV system Facility for Private House

1. Name of householder : L o u i N a m a n e
2. Code NO : A 9
3. Name of village : A b a o k o r o
4. Drawing of PV Facility

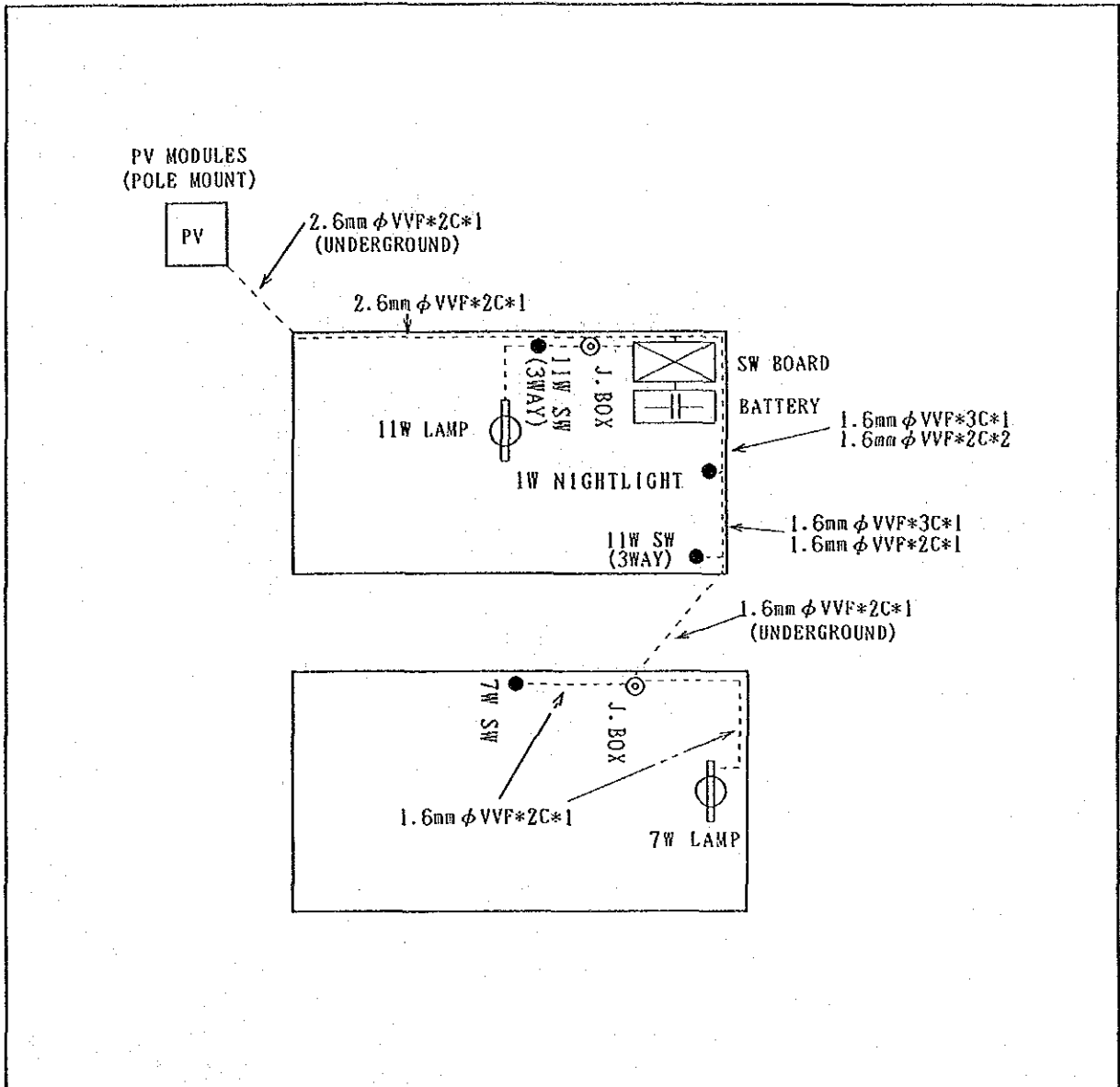

DATE	CHECKER	JUDGEMENT	DATE	CHECKER	JUDGEMENT

5. List of main equipment

No	Equipment Item	Quantity	No	Equipment Item	Quantity
1	PV Module	2 pcs	8	1W LED night light	1 ea
2	Pole Mount	1 set	9	No Fuse Braker(10(A))	1 ea
3	Charge Controller	1 ea	10	Main switch(30(A))	3 ea
4	Battery(12V-100Ah)	1 ea	11	Protection Fuse(15(A))	1 ea
5	Battery Box	1 ea	12	Junction Box	3 pcs
6	Fluorescent Lamp(11w)	1 ea	13	Switch(7(W))	1 pcs
7	Fluorescent Lamp(7w)	1 pcs	14	3way switch(11(W))	2 pcs

File of PV system Facility for Private House

1. Name of householder : Natiria Tamton
2. Code NO : A 1 0
3. Name of village : Abakoro
4. Drawing of PV Facility

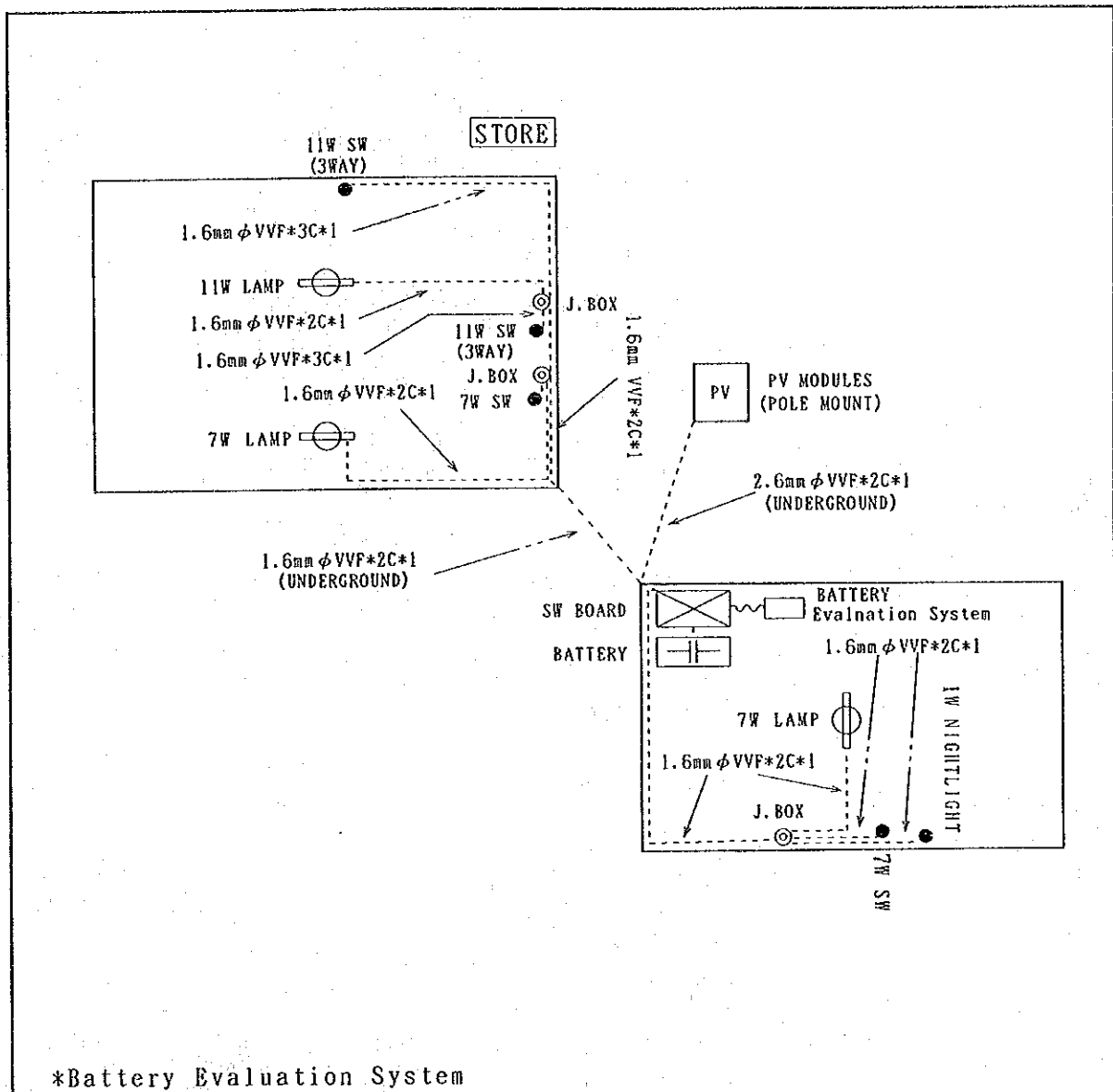

DATE	CHECKER	JUDGEMENT	DATE	CHECKER	JUDGEMENT

5. List of main equipment

	Equipment Item	Quantity		Equipment Item	Quantity
1	PV Module	2 pcs	8	1W LED night light	1 ea
2	Pole Mount	1 set	9	No Fuse Braker(10(A))	1 ea
3	Charge Controller	1 ea	10	Main switch(30(A))	3 ea
4	Battery(12V-100Ah)	1 ea	11	Protection Fuse(15(A))	1 ea
5	Battery Box	1 ea	12	Junction Box	3 pcs
6	Fluorescent Lamp(11w)	1 ea	13	Switch(7(W))	2 pcs
7	Fluorescent Lamp(7w)	2 pcs	14	3Way switch(11(W))	2 pcs

File of PV system Facility for Private House

1. Name of householder : O b e t a
2. Code NO : A 1 1
3. Name of village : A b a o k o r o
4. Drawing of PV Facility

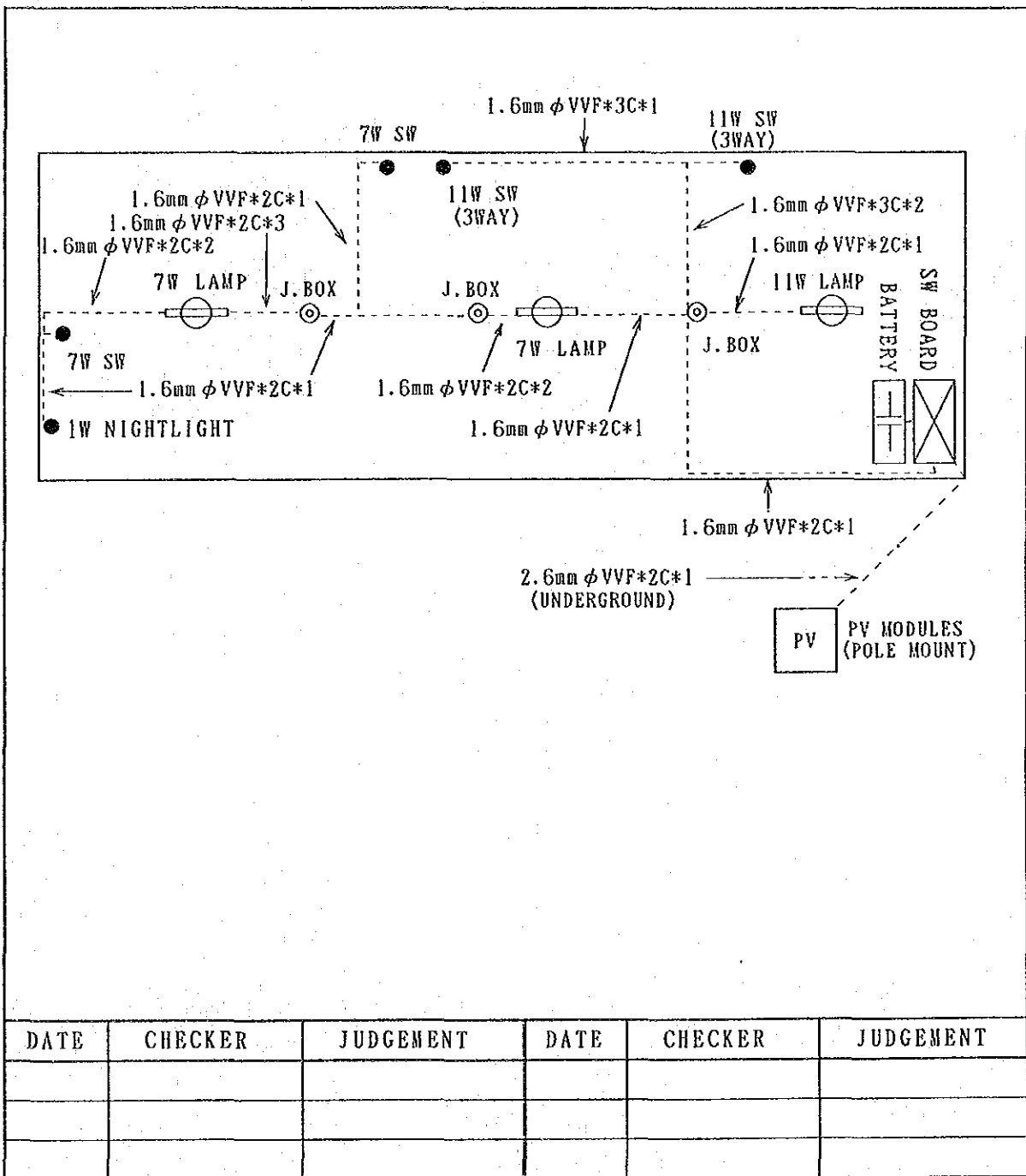

DATE	CHECKER	JUDGEMENT	DATE	CHECKER	JUDGEMENT

5. List of main equipment

	Equipment Item	Quantity		Equipment Item	Quantity
1	PV Module	2 pcs	8	1W LED night light	1 ea
2	Pole Mount	1 set	9	No Fuse Braker(10(A))	1 ea
3	Charge Controller	1 ea	10	Main switch(30(A))	3 ea
4	Battery(12V-100Ah)	1 ea	11	Protection Fuse(15(A))	1 ea
5	Battery Box	1 ea	12	Junction Box	3 pcs
6	Fluorescent Lamp(11w)	1 ea	13	Switch(7(W))	2 pcs
7	Fluorescent Lamp(7w)	2 pcs	14	3way switch(11(W))	2 pcs

File of PV system Facility for Private House

1. Name of householder : I e r u b a a r a
2. Code NO : A 1 6
3. Name of village : A b a o k o r o
4. Drawing of PV Facility

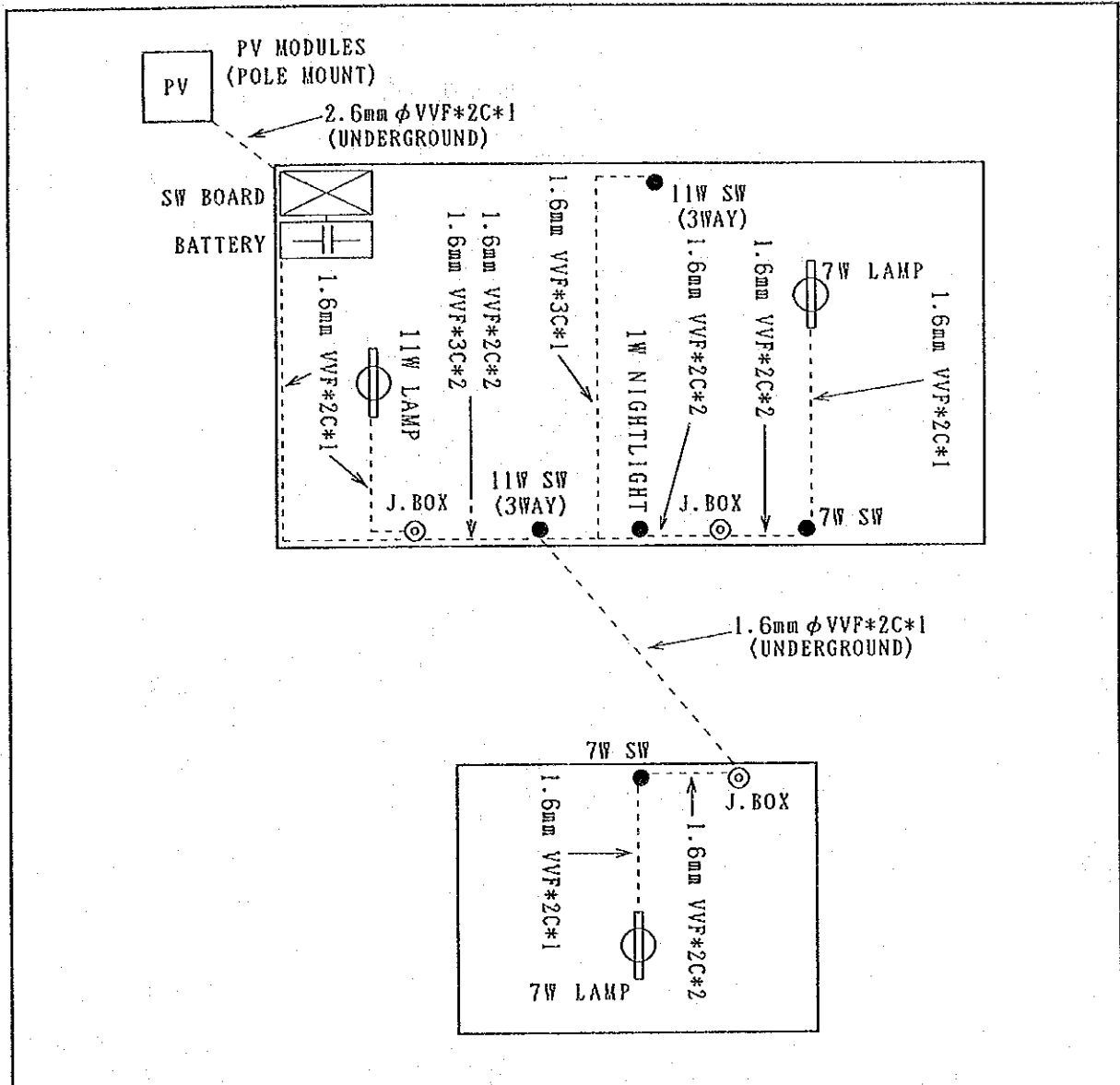

DATE	CHECKER	JUDGEMENT	DATE	CHECKER	JUDGEMENT

5. List of main equipment

Equipment Item	Quantity	Equipment Item	Quantity
1 PV Module	2 pcs	8 1W LED night light	1 ea
2 Pole Mount	1 set	9 No Fuse Braker(10(A))	1 ea
3 Charge Controller	1 ea	10 Main switch(30(A))	3 ea
4 Battery(12V-100Ah)	1 ea	11 Protection Fuse(15(A))	1 ea
5 Battery Box	1 ea	12 Junction Box	3 pcs
6 Fluorescent Lamp(11w)	1 ea	13 Switch(7(W))	2 pcs
7 Fluorescent Lamp(7w)	2 pcs	14 3Way switch(11(W))	2 pcs

File of PV system Facility for Private House

1. Name of householder : T e b u a k a
2. Code NO : A 1 7
3. Name of village : A b a o k o r o
4. Drawing of PV Facility

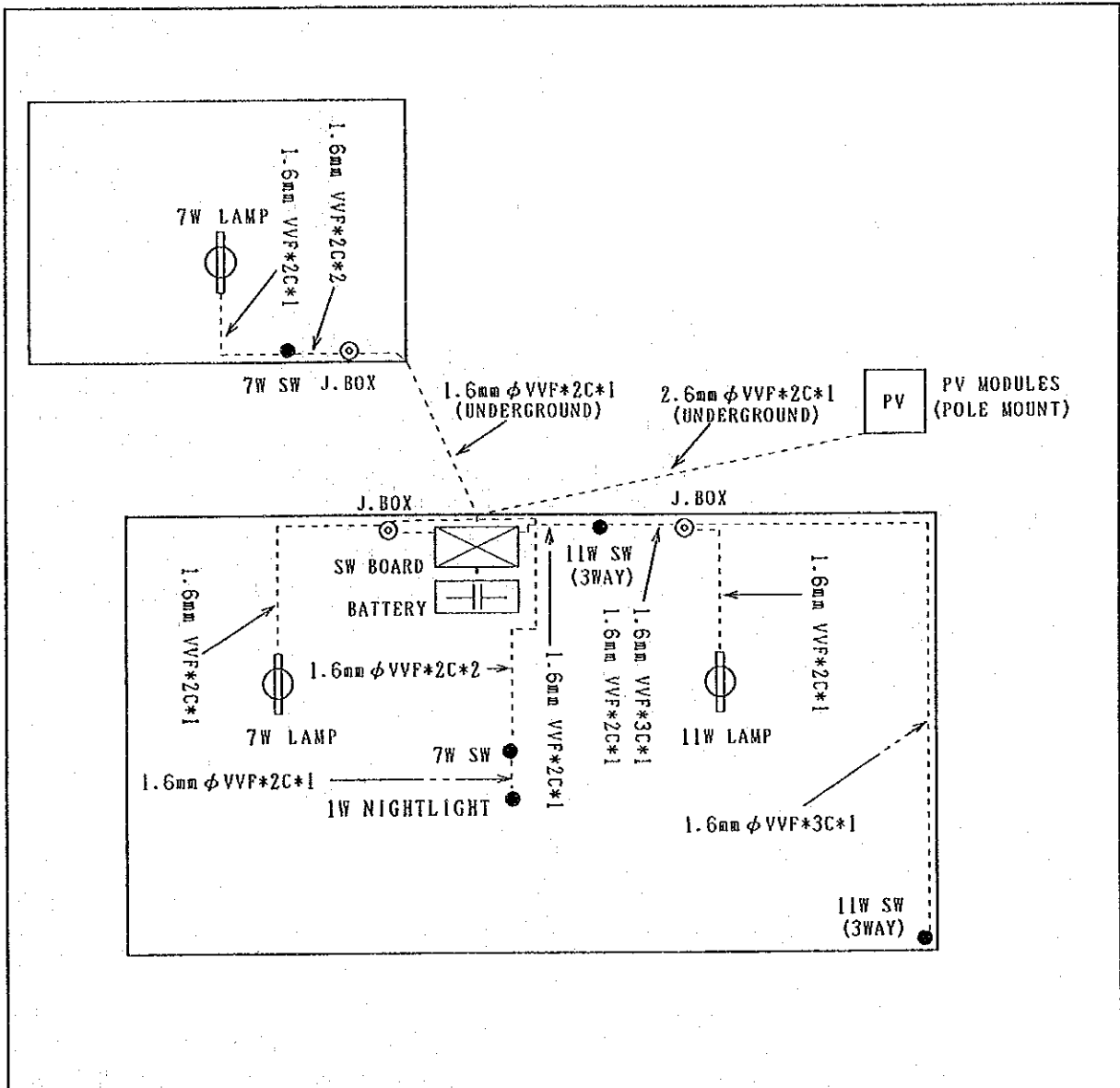

DATE	CHECKER	JUDGEMENT	DATE	CHECKER	JUDGEMENT

5. List of main equipment

	Equipment Item	Quantity		Equipment Item	Quantity
1	PV Module	2 pcs	8	1W LED night light	1 ea
2	Pole Mount	1 set	9	No Fuse Braker(10(A))	1 ea
3	Charge Controller	1 ea	10	Main switch(30(A))	3 ea
4	Battery(12V-100Ah)	1 ea	11	Protection Fuse(15(A))	1 ea
5	Battery Box	1 ea	12	Junction Box	3 pcs
6	Fluorescent Lamp(11w)	1 ea	13	Switch(7(W))	2 pcs
7	Fluorescent Lamp(7w)	2 pcs	14	3Way switch(11(W))	2 pcs

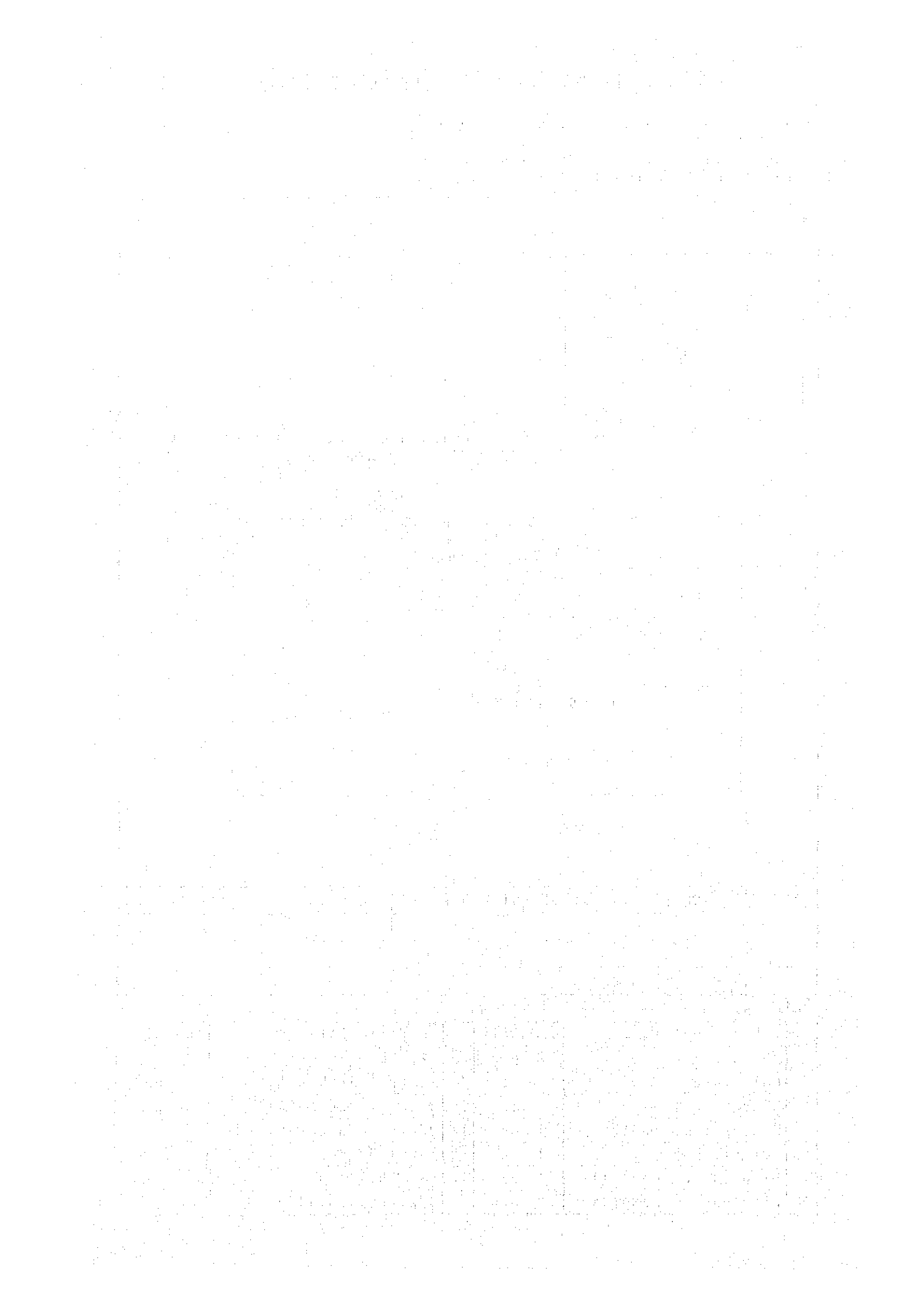

File of PV system Facility for Private House

1. Name of householder : T e k a k i a b o
2. Code NO : A 1 8
3. Name of village : A b a o k o r o
4. Drawing of PV Facility

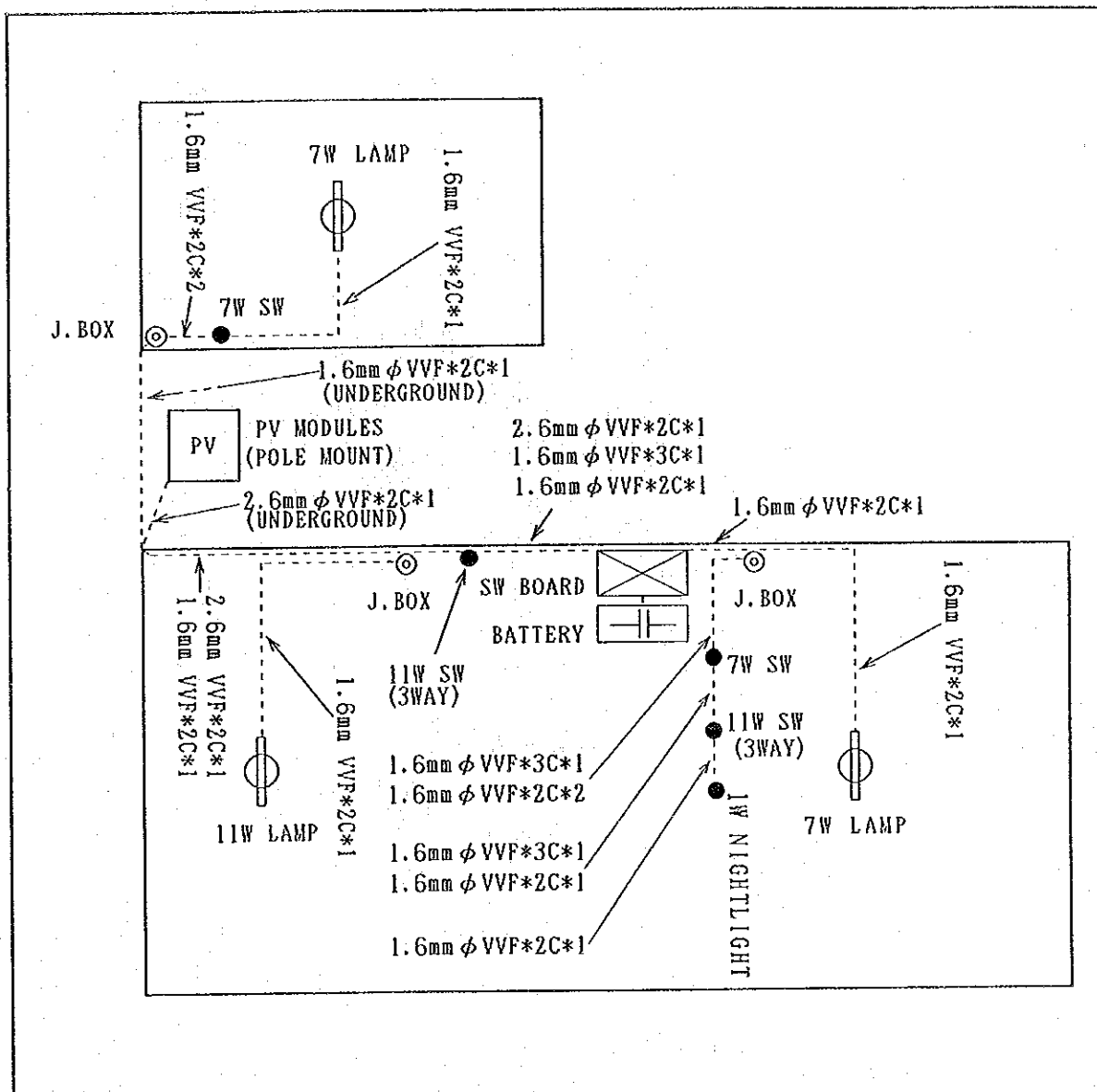

DATE	CHECKER	JUDGEMENT	DATE	CHECKER	JUDGEMENT

5. List of main equipment

No	Equipment Item	Quantity	No	Equipment Item	Quantity
1	PV Module	2 pcs	8	1W LED night light	1 ea
2	Pole Mount	1 set	9	No Fuse Braker(10(A))	1 ea
3	Charge Controller	1 ea	10	Main switch(30(A))	3 ea
4	Battery(12V-100Ah)	1 ea	11	Protection Fuse(15(A))	1 ea
5	Battery Box	1 ea	12	Junction Box	3 pcs
6	Fluorescent Lamp(11w)	1 ea	13	Switch(7(W))	2 pcs
7	Fluorescent Lamp(7w)	2 pcs	14	3way switch(11(W))	2 pcs

File of PV system Facility for Private House

1. Name of householder : M a k i n N g a t a u
2. Code NO : A 2 7
3. Name of village : A b a o k o r o
4. Drawing of PV Facility

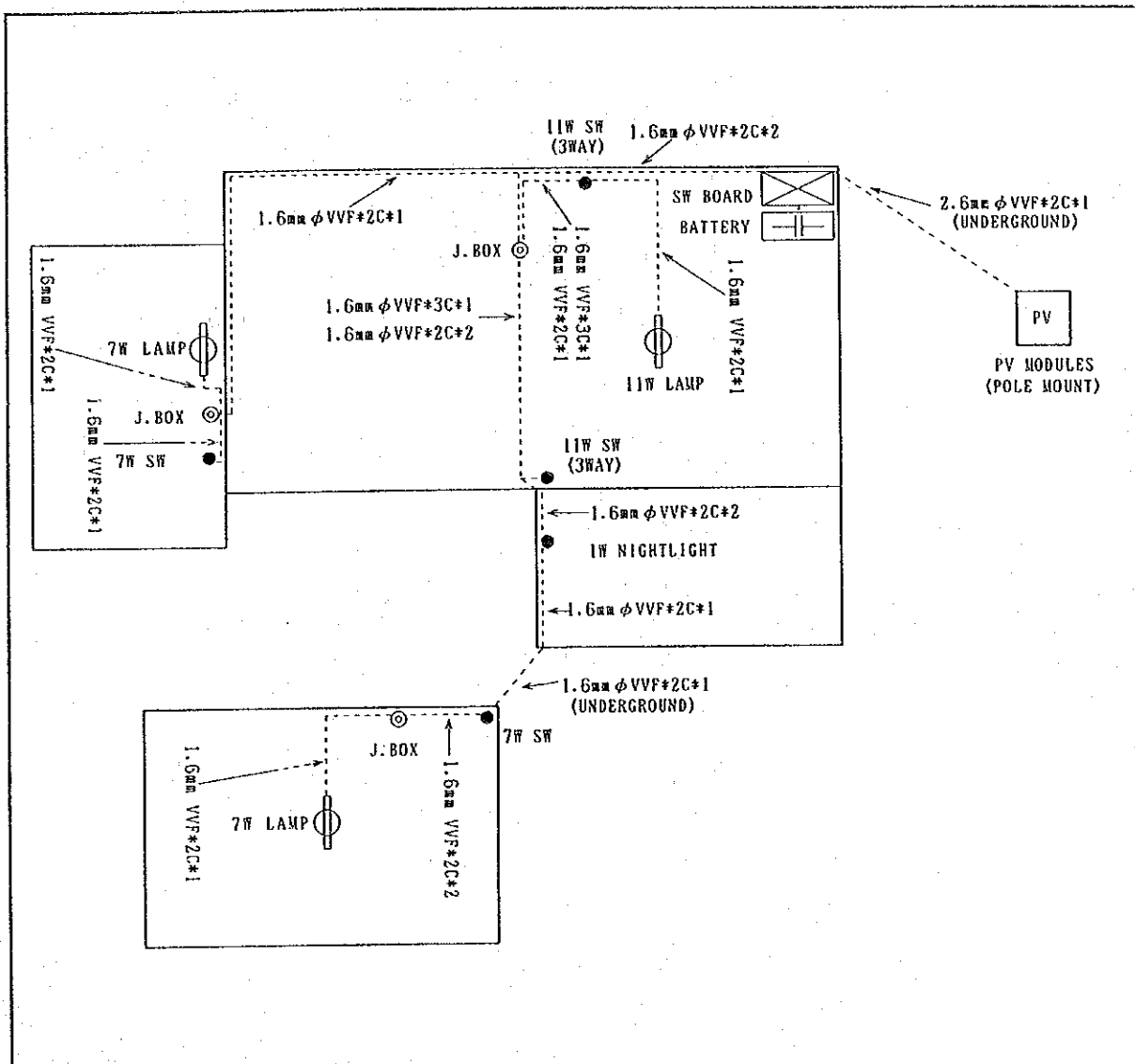

*SYSTEM Evaluation Facility

DATE	CHECKER	JUDGEMENT	DATE	CHECKER	JUDGEMENT

5. List of main equipment

Equipment Item	Quantity	Equipment Item	Quantity
1 PV Module	2 pcs	8 1W LED night light	1 ea
2 Pole Mount	1 set	9 No Fuse Braker(10(A))	1 ea
3 Charge Controller	1 ea	10 Main switch(30(A))	3 ea
4 Battery(12V-100Ah)	1 ea	11 Protection Fuse(15(A))	1 ea
5 Battery Box	1 ea	12 Junction Box	3 pcs
6 Fluorescent Lamp(11w)	1 ea	13 Switch(7(W))	2 pcs
7 Fluorescent Lamp(7w)	2 pcs	14 3way switch(11(W))	2 pcs

File of PV system Facility for Private House

1. Name of householder : T a u k a b a n
2. Code NO : A 2 9
3. Name of village : A b a o k o r o
4. Drawing of PV Facility

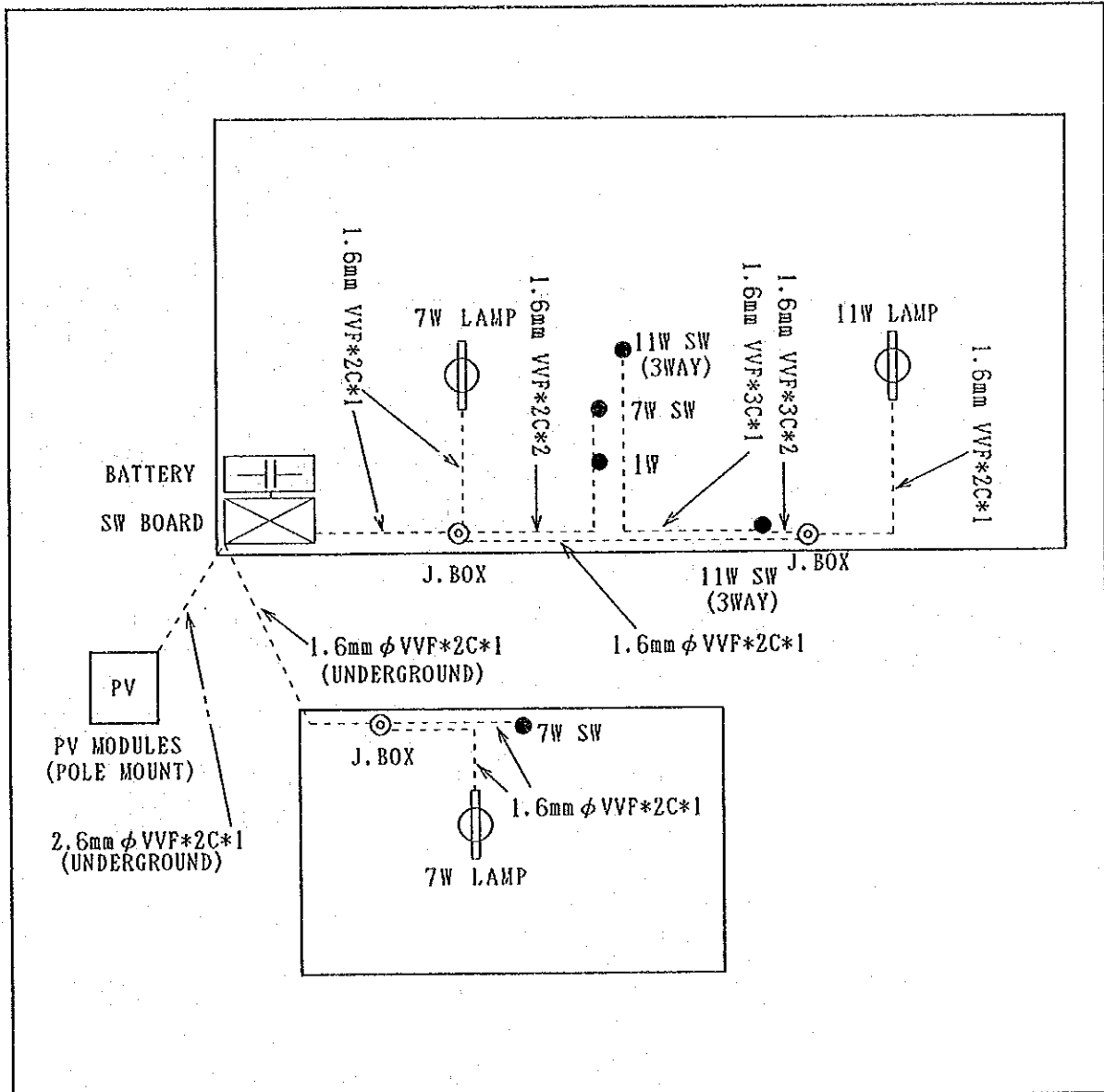

DATE	CHECKER	JUDGEMENT	DATE	CHECKER	JUDGEMENT

5. List of main equipment

No	Equipment Item	Quantity	No	Equipment Item	Quantity
1	PV Module	2 pcs	8	1W LED night light	1 ea
2	Pole Mount	1 set	9	No Fuse Braker(10(A))	1 ea
3	Charge Controller	1 ea	10	Main switch(30(A))	3 ea
4	Battery(12V-100Ah)	1 ea	11	Protection Fuse(15(A))	1 ea
5	Battery Box	1 ea	12	Junction Box	3 pcs
6	Fluorescent Lamp(11w)	1 ea	13	Switch(7(W))	2 pcs
7	Fluorescent Lamp(7w)	2 pcs	14	3Way switch(11(W))	2 pcs

File of PV system Facility for Private House

1. Name of householder : R i b a t i (K P C)
2. Code NO : A 3 2
3. Name of village : A b a o k o r o
4. Drawing of PV Facility

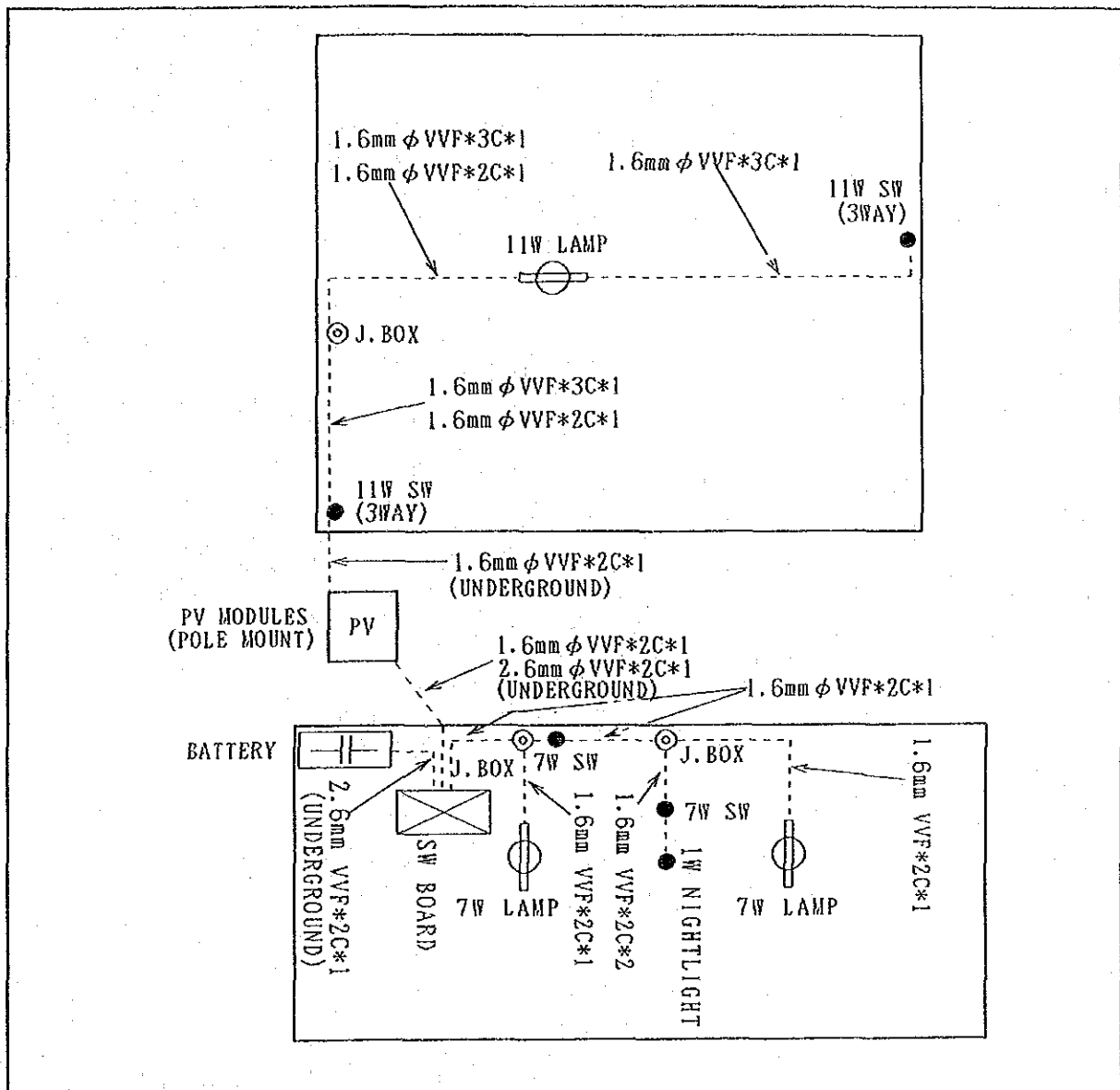

DATE	CHECKER	JUDGEMENT	DATE	CHECKER	JUDGEMENT

5. List of main equipment

No	Equipment Item	Quantity	No	Equipment Item	Quantity
1	PV Module	2 pcs	8	1W LED night light	1 ea
2	Pole Mount	1 set	9	No Fuse Braker(10(A))	1 ea
3	Charge Controller	1 ea	10	Main switch(30(A))	3 ea
4	Battery(12V-100Ah)	1 ea	11	Protection Fuse(15(A))	1 ea
5	Battery Box	1 ea	12	Junction Box	3 pcs
6	Fluorescent Lamp(11w)	1 ea	13	Switch(7(W))	2 pcs
7	Fluorescent Lamp(7w)	2 pcs	14	3Way switch(11(W))	2 pcs

File of PV system Facility for Private House

1. Name of householder : T i o t i
2. Code NO : A 3 3
3. Name of village : A b a o k o r o
4. Drawing of PV Facility

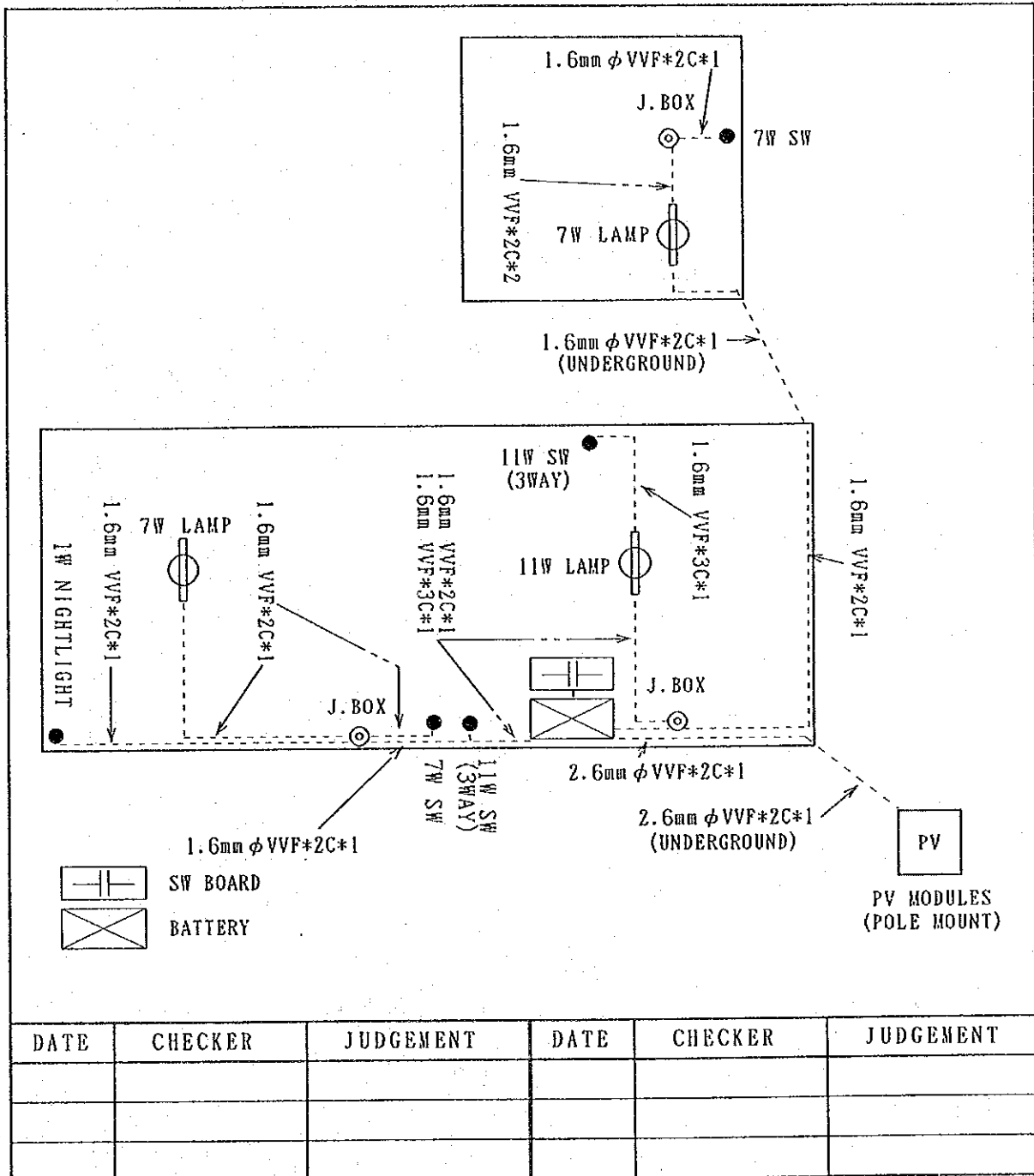

5. List of main equipment

Equipment Item	Quantity	Equipment Item	Quantity
1 PV Module	2 pcs	8 1W LED night light	1 ea
2 Pole Mount	1 set	9 No Fuse Braker(10(A))	1 ea
3 Charge Controller	1 ea	10 Main switch(30(A))	3 ea
4 Battery(12V-100Ah)	1 ea	11 Protection Fuse(15(A))	1 ea
5 Battery Box	1 ea	12 Junction Box	3 pcs
6 Fluorescent Lamp(11w)	1 ea	13 Switch(7(W))	2 pcs
7 Fluorescent Lamp(7w)	2 pcs	14 3way switch(11(W))	2 pcs

File of PV system Facility for Private House

1. Name of householder : A b a u a
2. Code NO : A 3 5
3. Name of village : A b a o k o r o
4. Drawing of PV Facility

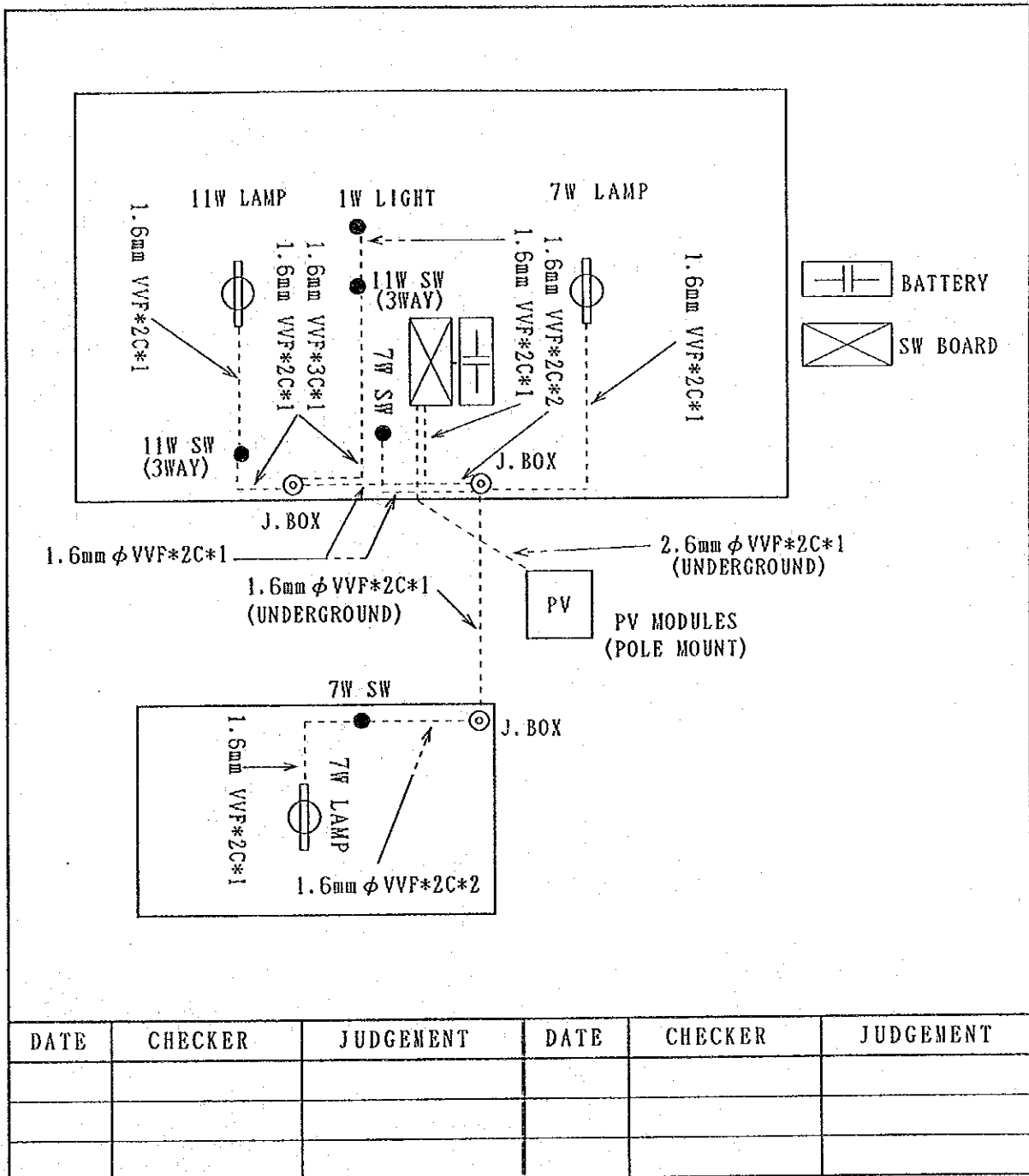

5. List of main equipment

No	Equipment Item	Quantity	No	Equipment Item	Quantity
1	PV Module	2 pcs	8	1W LED night light	1 ea
2	Pole Mount	1 set	9	No Fuse Braker(10(A))	1 ea
3	Charge Controller	1 ea	10	Main switch(30(A))	3 ea
4	Battery(12V-100Ah)	1 ea	11	Protection Fuse(15(A))	1 ea
5	Battery Box	1 ea	12	Junction Box	3 pcs
6	Fluorescent Lamp(11w)	1 ea	13	Switch(7(W))	2 pcs
7	Fluorescent Lamp(7w)	2 pcs	14	3way switch(11(W))	2 pcs

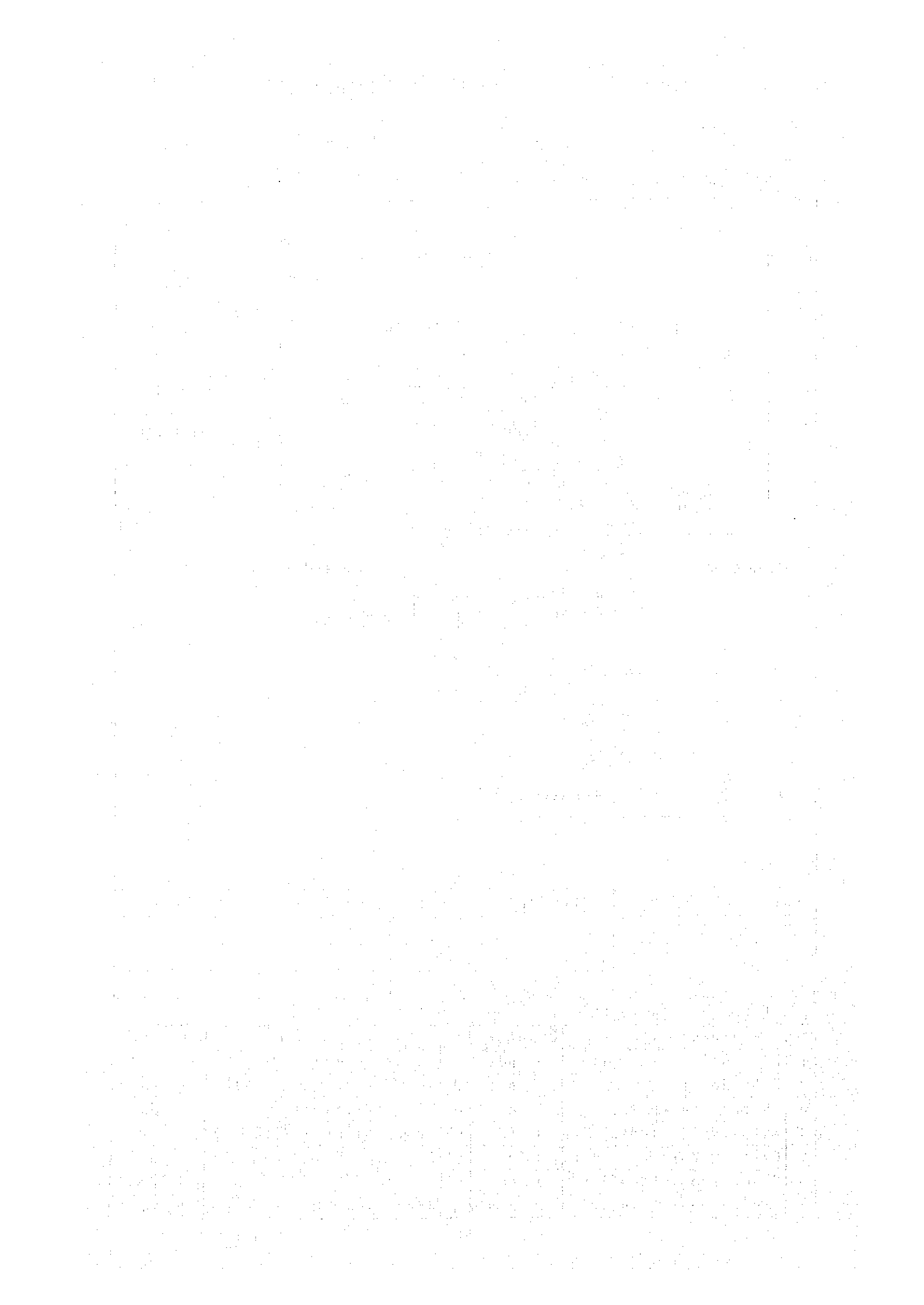

File of PV system Facility for Private House

1. Name of householder : Danny
2. Code NO : A 3 6
3. Name of village : A b a o k o r o
4. Drawing of PV Facility

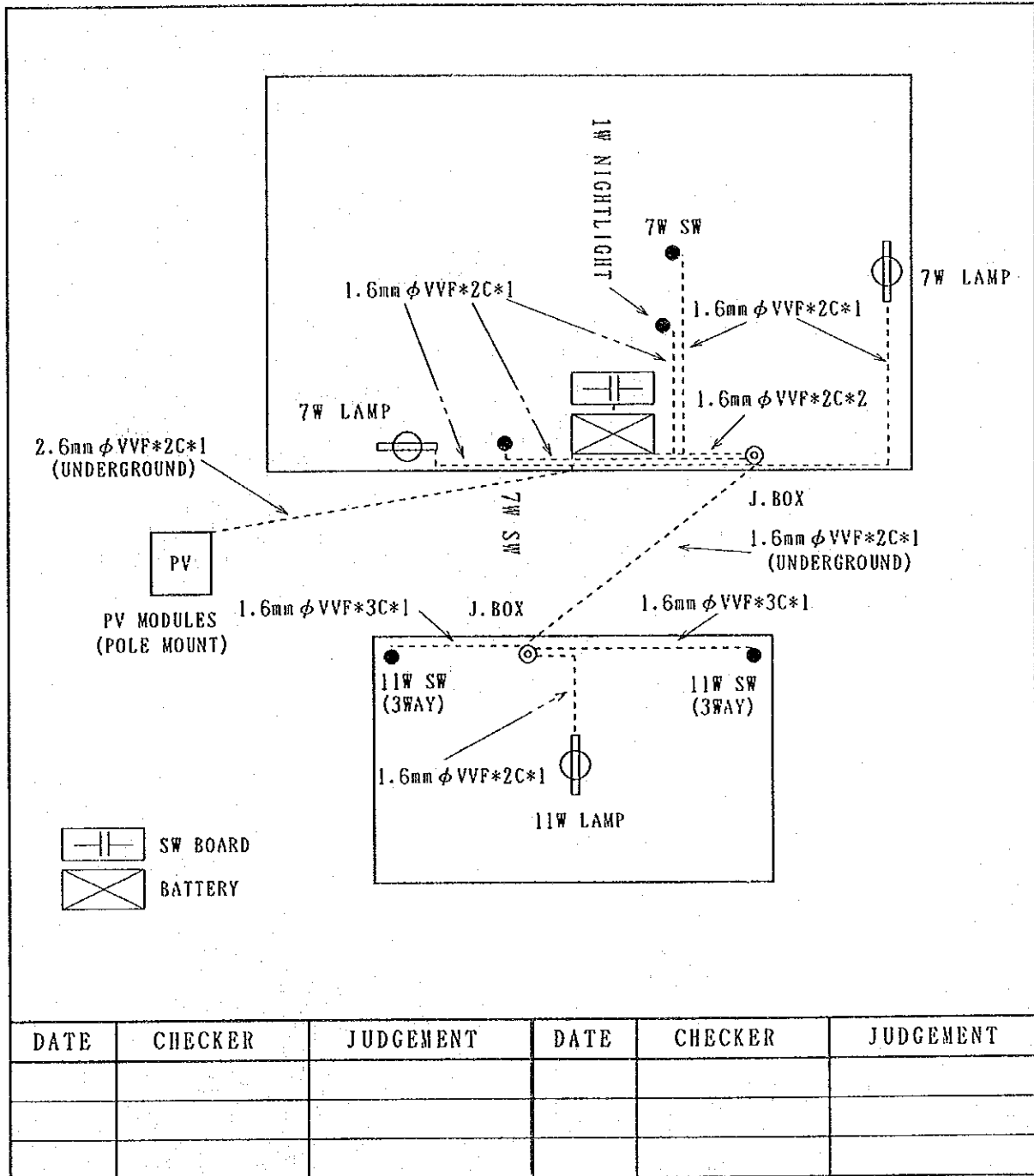

5. List of main equipment

	Equipment Item	Quantity		Equipment Item	Quantity
1	PV Module	2 pcs	8	1W LED night light	1 ea
2	Pole Mount	1 set	9	No Fuse Braker(10(A))	1 ea
3	Charge Controller	1 ea	10	Main switch(30(A))	3 ea
4	Battery(12V-100Ah)	1 ea	11	Protection Fuse(15(A))	1 ea
5	Battery Box	1 ea	12	Junction Box	3 pcs
6	Fluorescent Lamp(11w)	1 ea	13	Switch(7(W))	2 pcs
7	Fluorescent Lamp(7w)	2 pcs	14	3way switch(11(W))	2 pcs

File of PV system Facility for Private House

1. Name of householder : M a t i o t a
2. Code NO : A 3 7
3. Name of village : A b a o k o r o
4. Drawing of PV Facility

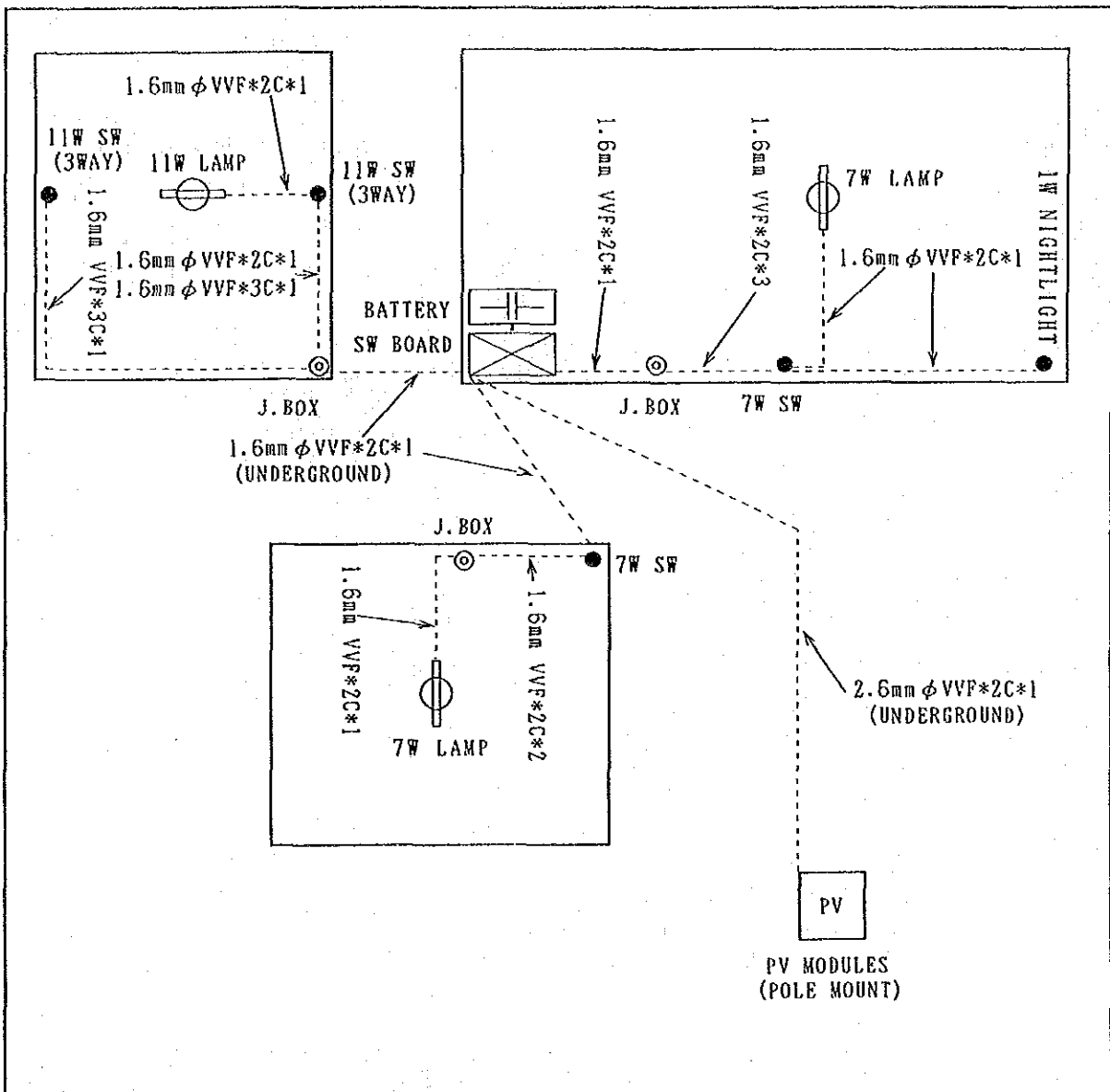

DATE	CHECKER	JUDGEMENT	DATE	CHECKER	JUDGEMENT

5. List of main equipment

No	Equipment Item	Quantity	No	Equipment Item	Quantity
1	PV Module	2 pcs	8	1W LED night light	1 ea
2	Pole Mount	1 set	9	No Fuse Braker(10(A))	1 ea
3	Charge Controller	1 ea	10	Main switch(30(A))	3 ea
4	Battery(12V-100Ah)	1 ea	11	Protection Fuse(15(A))	1 ea
5	Battery Box	1 ea	12	Junction Box	3 pcs
6	Fluorescent Lamp(11w)	1 ea	13	Switch(7(W))	2 pcs
7	Fluorescent Lamp(7w)	2 pcs	14	3Way switch(11(W))	2 pcs

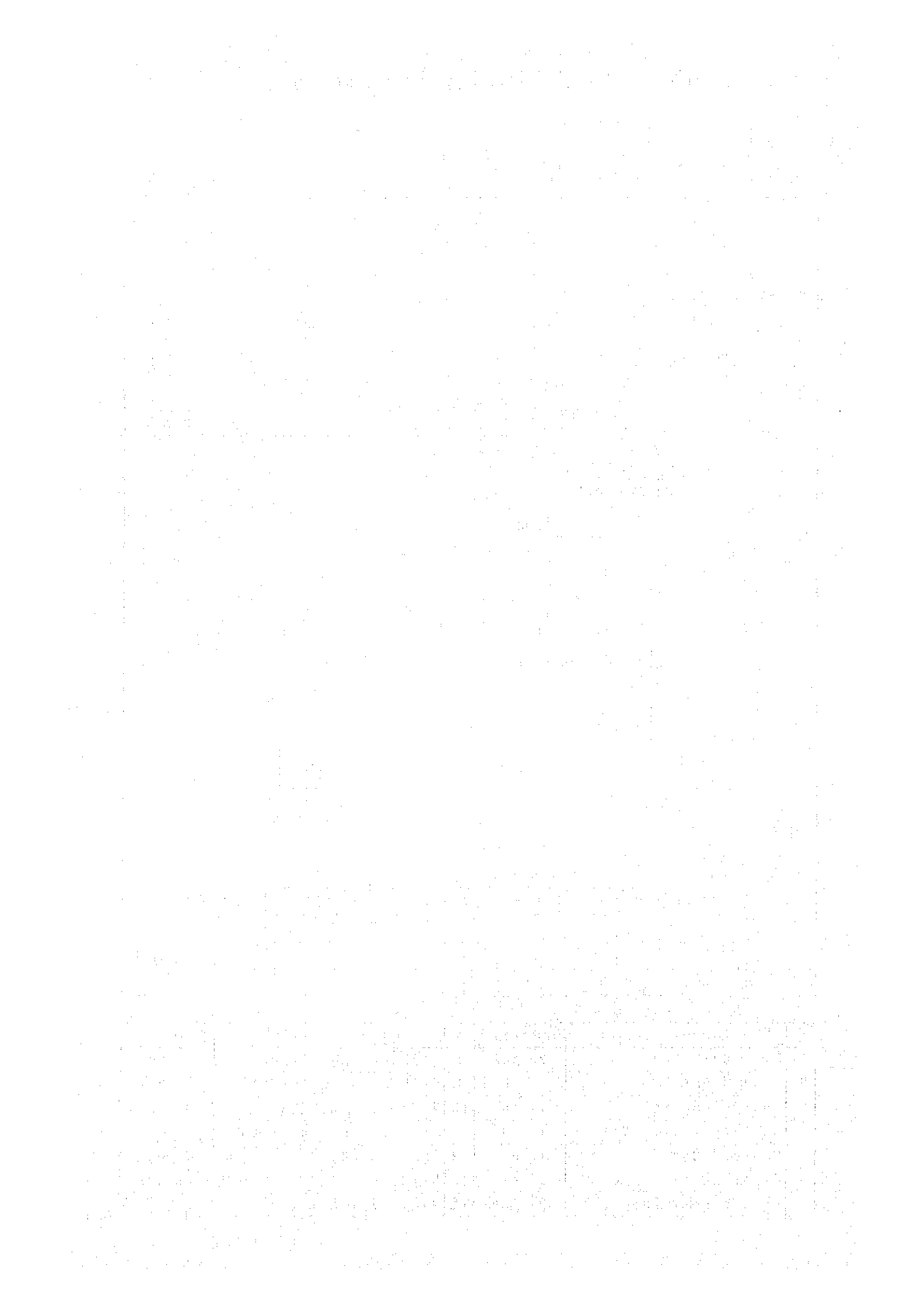

File of PV system Facility for Private House

1. Name of householder : A m b o u
2. Code NO :
3. Name of village : A b a o k o r o
4. Drawing of PV Facility

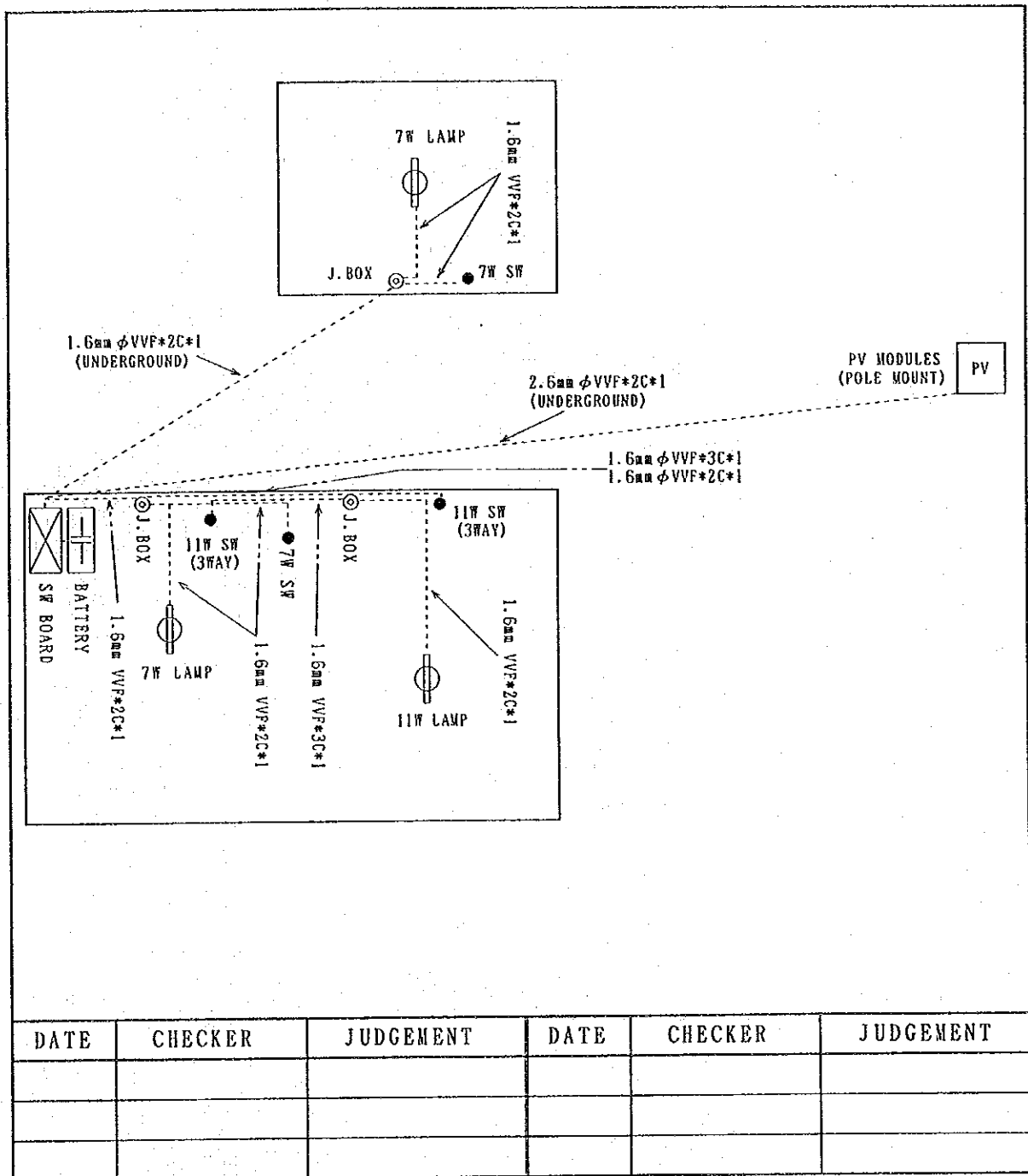

DATE	CHECKER	JUDGEMENT	DATE	CHECKER	JUDGEMENT

5. List of main equipment

	Equipment Item	Quantity		Equipment Item	Quantity
1	PV Module	2 pcs	8	1W LED night light	1 ea
2	Pole Mount	1 set	9	No Fuse Braker(10(A))	1 ea
3	Charge Controller	1 ea	10	Main switch(30(A))	3 ea
4	Battery(12V-100Ah)	1 ea	11	Protection Fuse(15(A))	1 ea
5	Battery Box	1 ea	12	Junction Box	3 pcs
6	Fluorescent Lamp(11w)	1 ea	13	Switch(7(W))	2 pcs
7	Fluorescent Lamp(7w)	2 pcs	14	3Way switch(11(W))	2 pcs

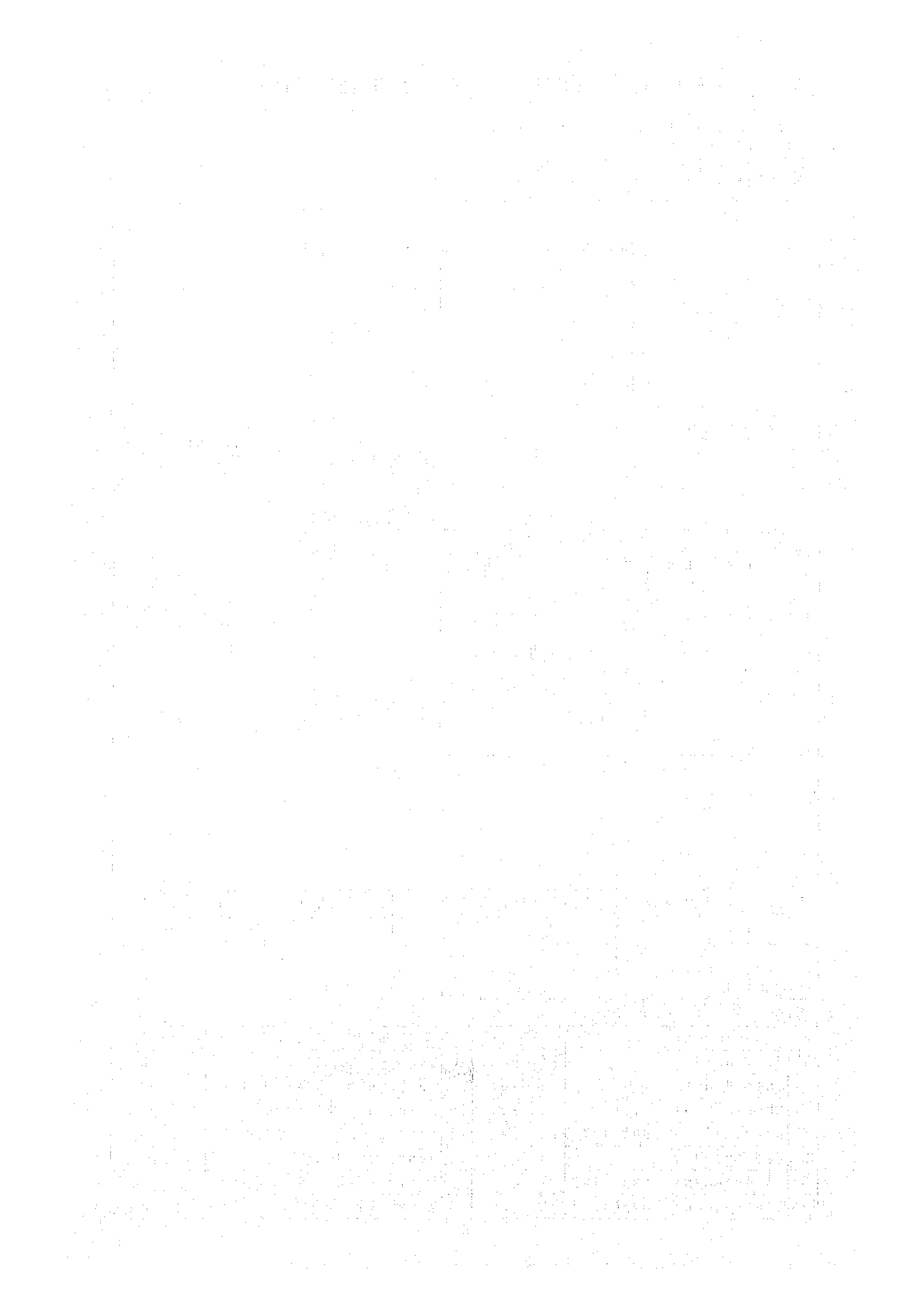

File of PV system Facility for Private House

1. Name of householder : B a u r o
2. Code NO :
3. Name of village : A b a o k o r o
4. Drawing of PV Facility

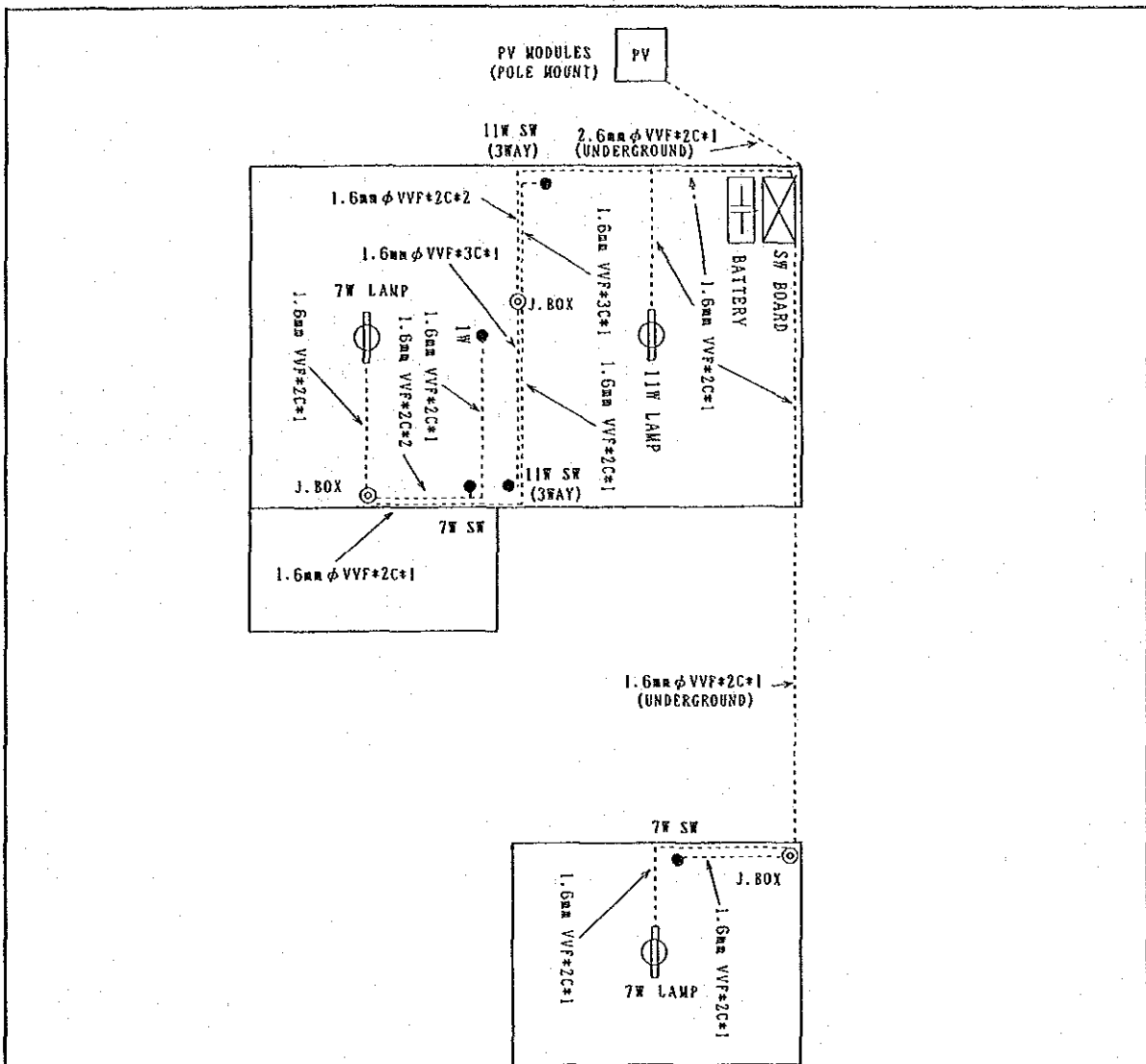

*System Evaluation facility

DATE	CHECKER	JUDGEMENT	DATE	CHECKER	JUDGEMENT

5. List of main equipment

	Equipment Item	Quantity		Equipment Item	Quantity
1	PV Module	2 pcs	8	1W LED night light	1 ea
2	Pole Mount	1 set	9	No Fuse Braker(10(A))	1 ea
3	Charge Controller	1 ea	10	Main switch(30(A))	3 ea
4	Battery(12V-100Ah)	1 ea	11	Protection Fuse(15(A))	1 ea
5	Battery Box	1 ea	12	Junction Box	3 pcs
6	Fluorescent Lamp(11w)	1 ea	13	Switch(7(W))	2 pcs
7	Fluorescent Lamp(7w)	2 pcs	14	3Way switch(11(W))	2 pcs

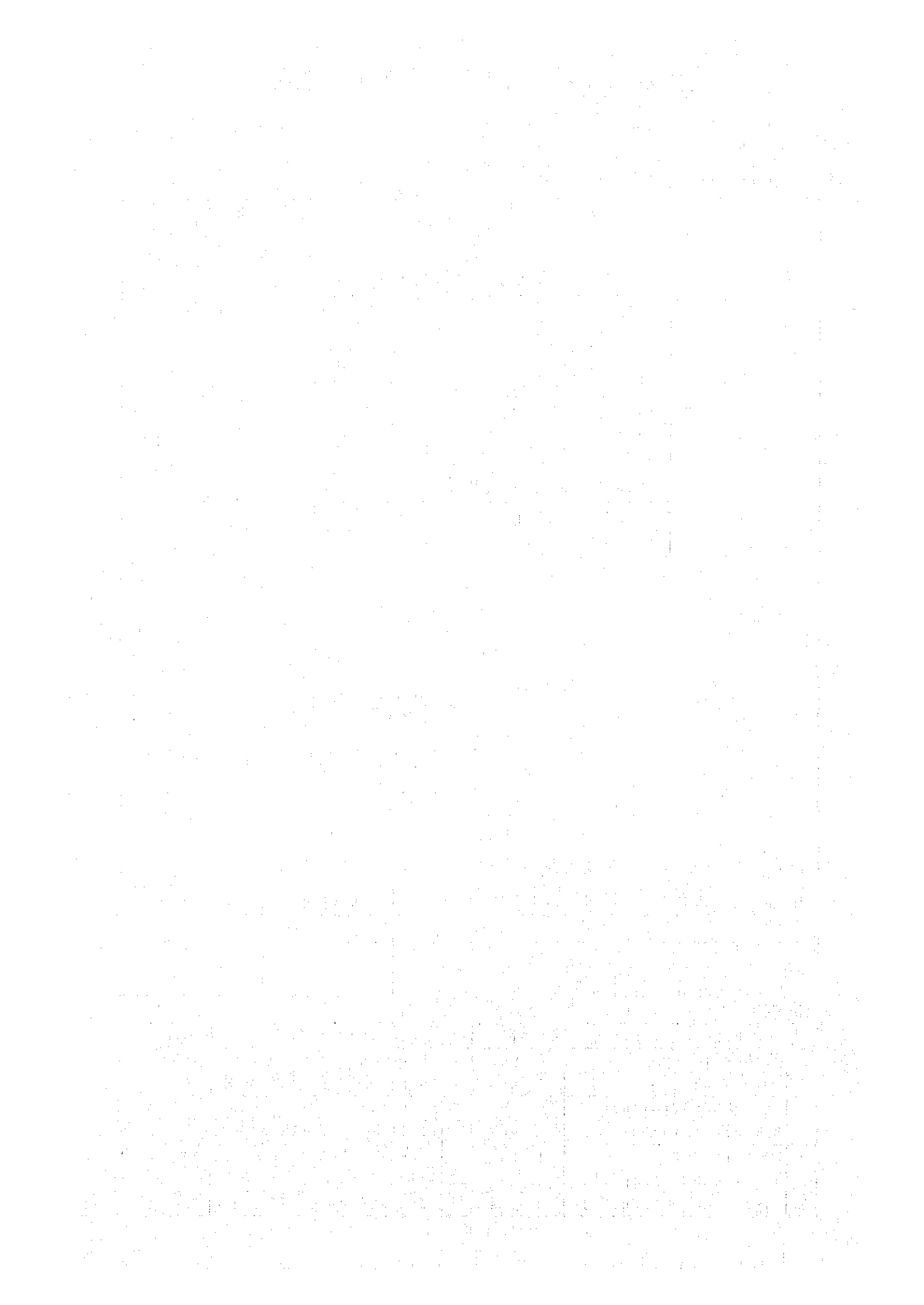

File of PV system Facility for Private House

1. Name of householder : K a o b u n a n g
2. Code NO :
3. Name of village : A b a o k o r o
4. Drawing of PV Facility

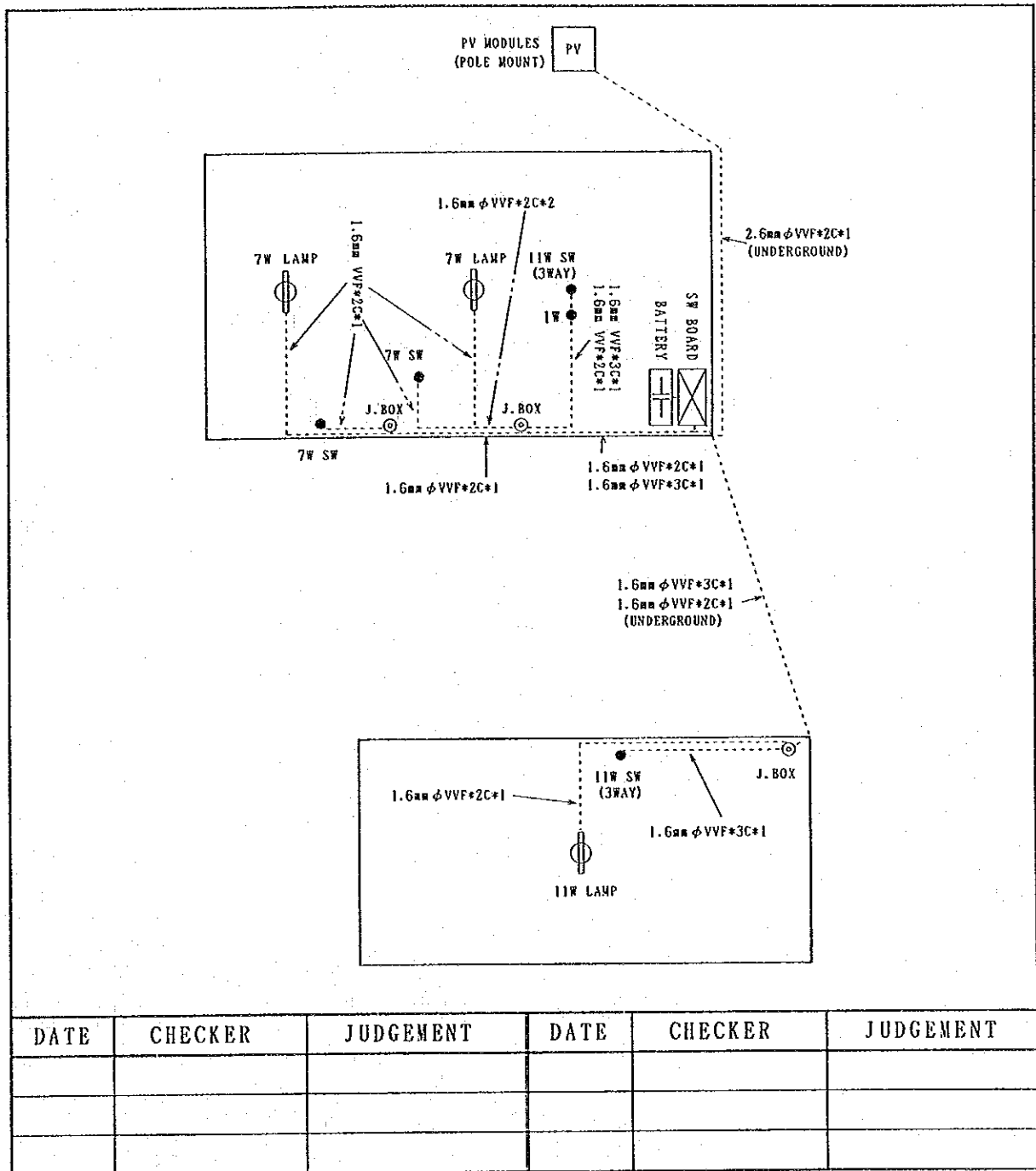

DATE	CHECKER	JUDGEMENT	DATE	CHECKER	JUDGEMENT

5. List of main equipment

No	Equipment Item	Quantity	No	Equipment Item	Quantity
1	PV Module	2 pcs	8	1W LED night light	1 ea
2	Pole Mount	1 set	9	No Fuse Braker(10(A))	1 ea
3	Charge Controller	1 ea	10	Main switch(30(A))	3 ea
4	Battery(12V-100Ah)	1 ea	11	Protection Fuse(15(A))	1 ea
5	Battery Box	1 ea	12	Junction Box	3 pcs
6	Fluorescent Lamp(11w)	1 ea	13	Switch(7(W))	2 pcs
7	Fluorescent Lamp(7w)	2 pcs	14	3way switch(11(W))	2 pcs

File of PV system Facility for Private House

1. Name of householder : T e k a t a u
2. Code NO :
3. Name of village : A b a o k o r o
4. Drawing of PV Facility

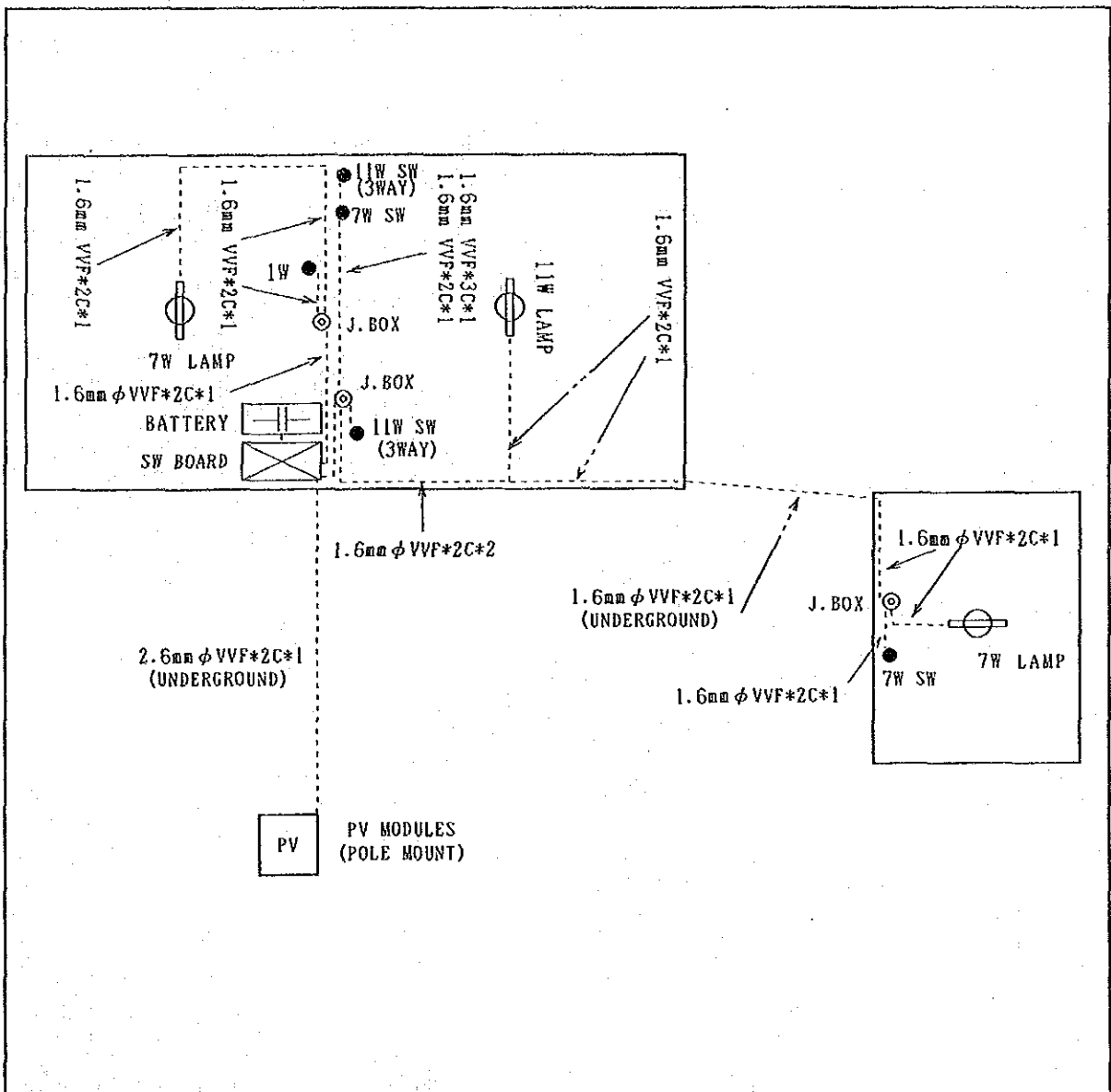

DATE	CHECKER	JUDGEMENT	DATE	CHECKER	JUDGEMENT

5. List of main equipment

No	Equipment Item	Quantity	No	Equipment Item	Quantity
1	PV Module	2 pcs	8	1W LED night light	1 ea
2	Pole Mount	1 set	9	No Fuse Braker(10(A))	1 ea
3	Charge Controller	1 ea	10	Main switch(30(A))	3 ea
4	Battery(12V-100Ah)	1 ea	11	Protection Fuse(15(A))	1 ea
5	Battery Box	1 ea	12	Junction Box	3 pcs
6	Fluorescent Lamp(11w)	1 ea	13	Switch(7(W))	2 pcs
7	Fluorescent Lamp(7w)	2 pcs	14	3Way switch(11(W))	2 pcs

File of PV system Facility for Private House

1. Name of householder : T e k e r a o i
2. Code NO :
3. Name of village : A b a o k o r o
4. Drawing of PV Facility

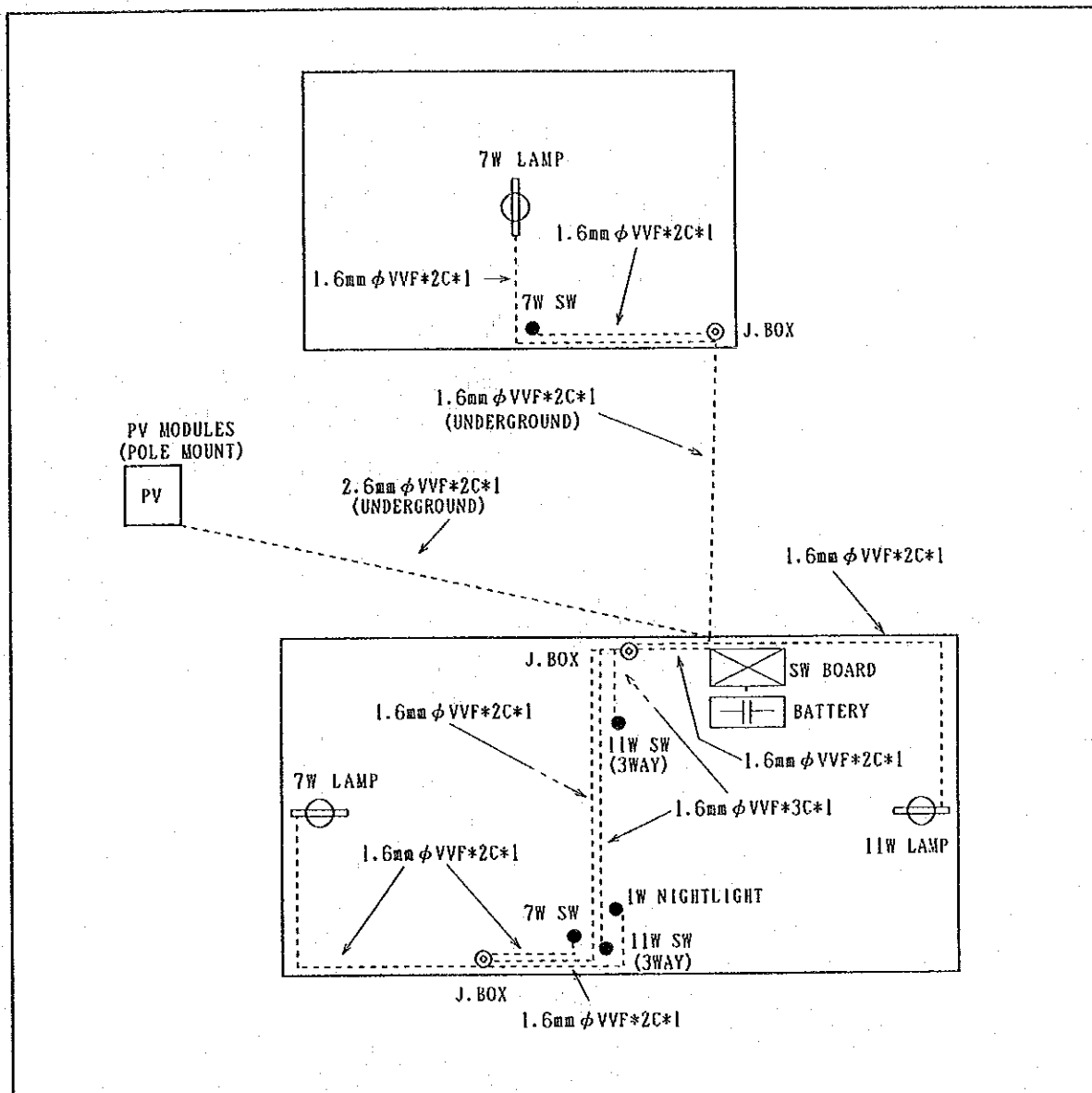

DATE	CHECKER	JUDGEMENT	DATE	CHECKER	JUDGEMENT

5. List of main equipment

No	Equipment Item	Quantity	No	Equipment Item	Quantity
1	PV Module	2 pcs	8	1W LED night light	1 ea
2	Pole Mount	1 set	9	No Fuse Braker(10(A))	1 ea
3	Charge Controller	1 ea	10	Main switch(30(A))	3 ea
4	Battery(12V-100Ah)	1 ea	11	Protection Fuse(15(A))	1 ea
5	Battery Box	1 ea	12	Junction Box	3 pcs
6	Fluorescent Lamp(11w)	1 ea	13	Switch(7(W))	2 pcs
7	Fluorescent Lamp(7w)	2 pcs	14	3Way switch(11(W))	2 pcs

File of PV system Facility for Private House

1. Name of householder : T e n a g i m a u
2. Code NO :
3. Name of village : A b a o k o r o
4. Drawing of PV Facility

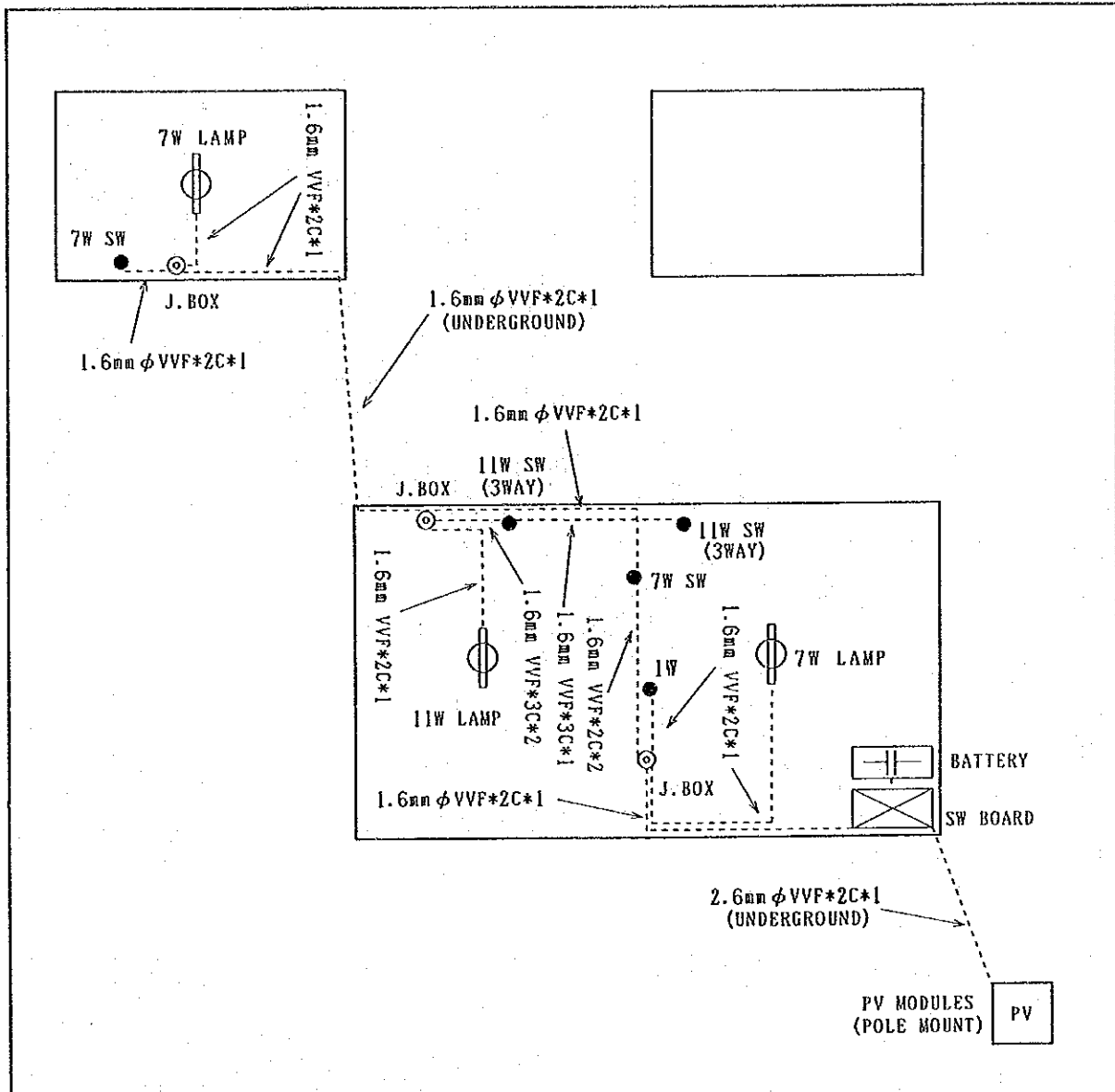

DATE	CHECKER	JUDGEMENT	DATE	CHECKER	JUDGEMENT

5. List of main equipment

No.	Equipment Item	Quantity	No.	Equipment Item	Quantity
1	PV Module	2 pcs	8	1W LED night light	1 ea
2	Pole Mount	1 set	9	No Fuse Braker(10(A))	1 ea
3	Charge Controller	1 ea	10	Main switch(30(A))	3 ea
4	Battery(12V-100Ah)	1 ea	11	Protection Fuse(15(A))	1 ea
5	Battery Box	1 ea	12	Junction Box	3 pcs
6	Fluorescent Lamp(11w)	1 ea	13	Switch(7(W))	2 pcs
7	Fluorescent Lamp(7w)	2 pcs	14	3way switch(11(W))	2 pcs



File of PV system Facility for Private House

1. Name of householder : T e t a k e
2. Code NO :
3. Name of village : A b a o k o r o
4. Drawing of PV Facility

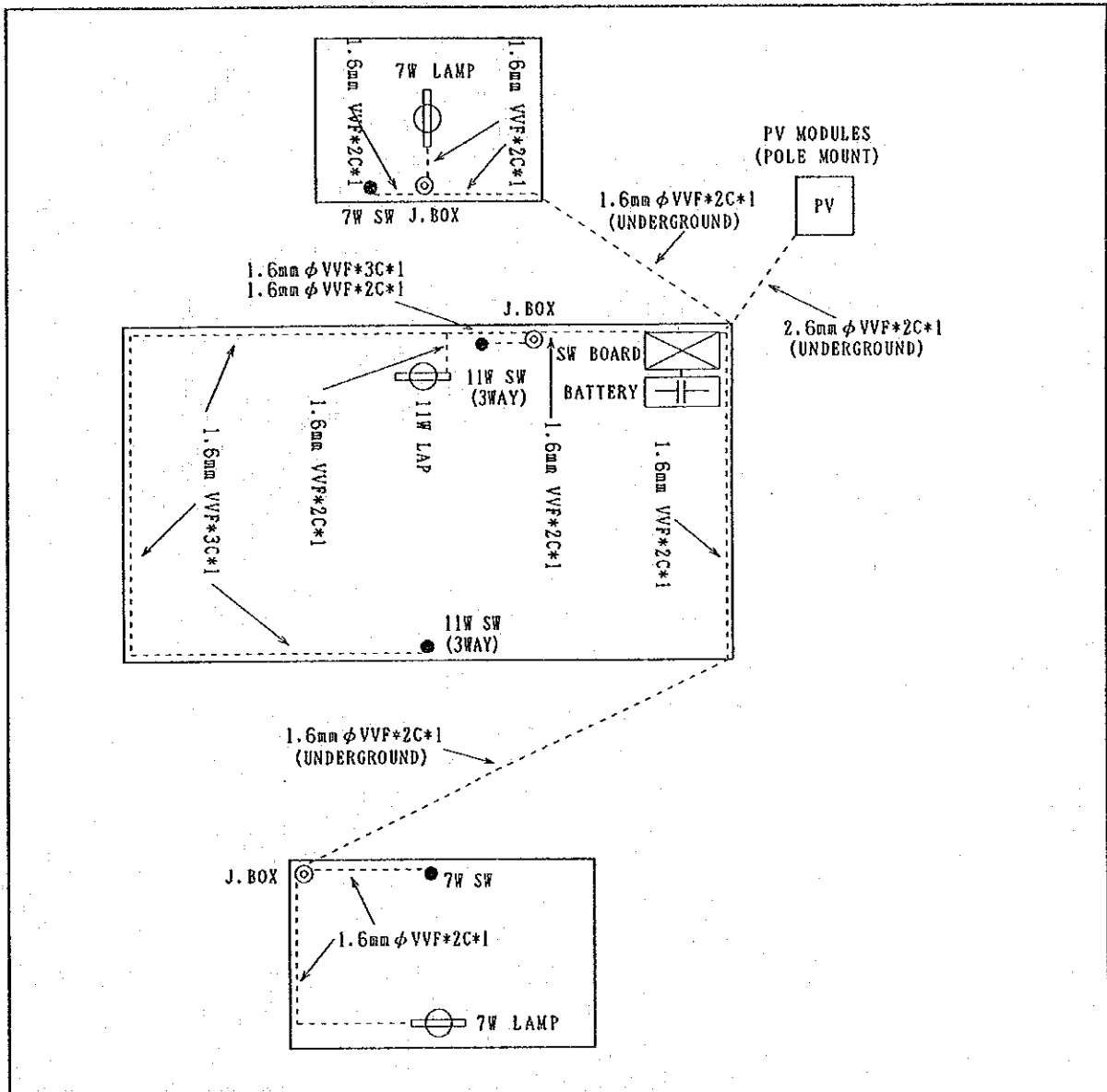

DATE	CHECKER	JUDGEMENT	DATE	CHECKER	JUDGEMENT

5. List of main equipment

Equipment Item	Quantity	Equipment Item	Quantity
1 PV Module	2 pcs	8 1W LED night light	1 ea
2 Pole Mount	1 set	9 No Fuse Braker(10(A))	1 ea
3 Charge Controller	1 ea	10 Main switch(30(A))	3 ea
4 Battery(12V-100Ah)	1 ea	11 Protection Fuse(15(A))	1 ea
5 Battery Box	1 ea	12 Junction Box	3 pcs
6 Fluorescent Lamp(11w)	1 ea	13 Switch(7(W))	2 pcs
7 Fluorescent Lamp(7w)	2 pcs	14 3way switch(11(W))	2 pcs

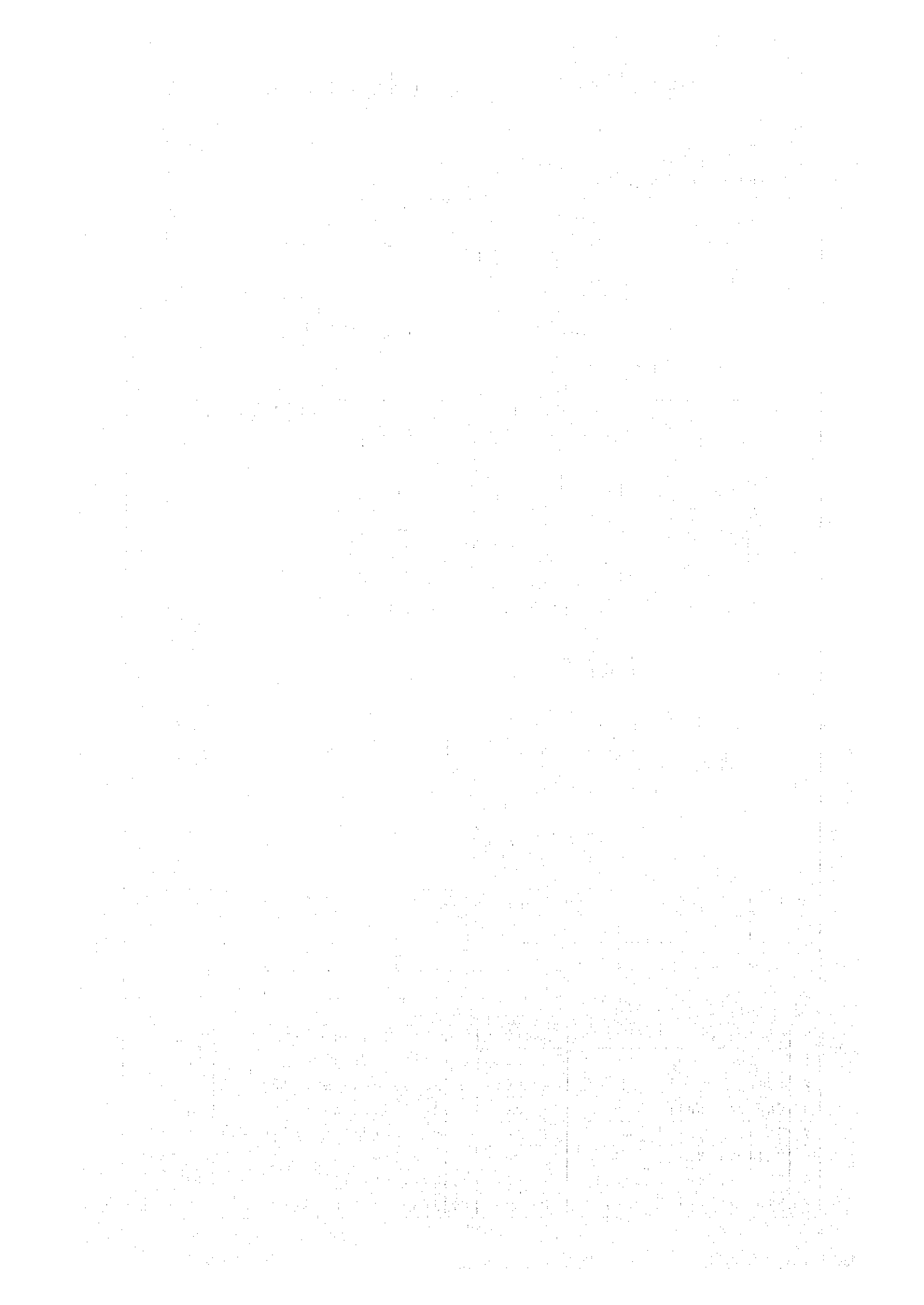

File of PV system Facility for Private House

1. Name of householder : B i i t a
2. Code NO :
3. Name of village : A b a o k o r o
4. Drawing of PV Facility

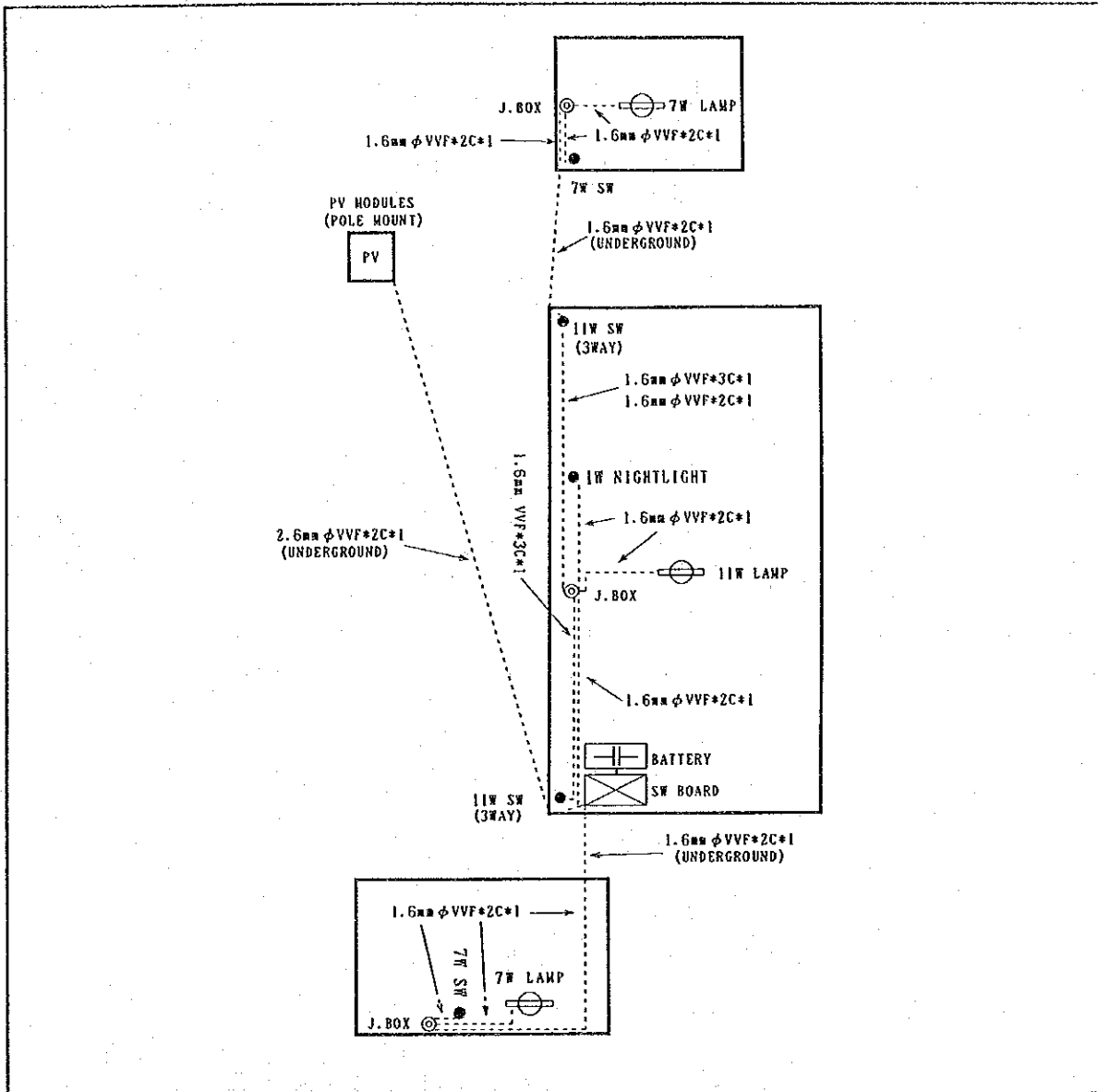

DATE	CHECKER	JUDGEMENT	DATE	CHECKER	JUDGEMENT

5. List of main equipment

	Equipment Item	Quantity		Equipment Item	Quantity
1	PV Module	2 pcs	8	1W LED night light	1 ea
2	Pole Mount	1 set	9	No Fuse Braker(10(A))	1 ea
3	Charge Controller	1 ea	10	Main switch(30(A))	3 ea
4	Battery(12V-100Ah)	1 ea	11	Protection Fuse(15(A))	1 ea
5	Battery Box	1 ea	12	Junction Box	3 pcs
6	Fluorescent Lamp(11w)	1 ea	13	Switch(7(W))	2 pcs
7	Fluorescent Lamp(7w)	2 pcs	14	3Way switch(11(W))	2 pcs

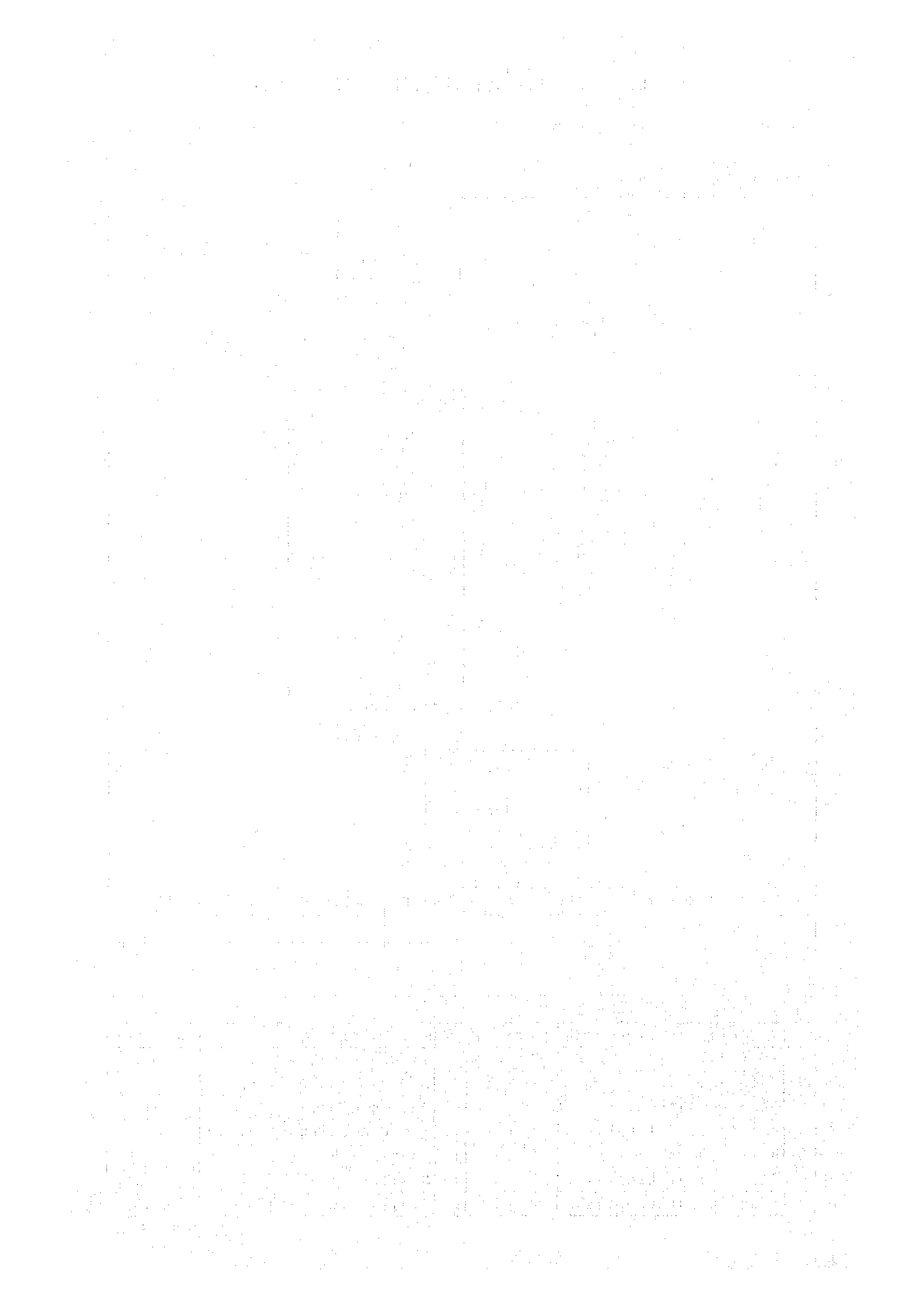

File of PV system Facility for Private House

1. Name of householder : B e i a R u a i a
2. Code NO : M 1
3. Name of village : M a r e n a n u k a
4. Drawing of PV Facility

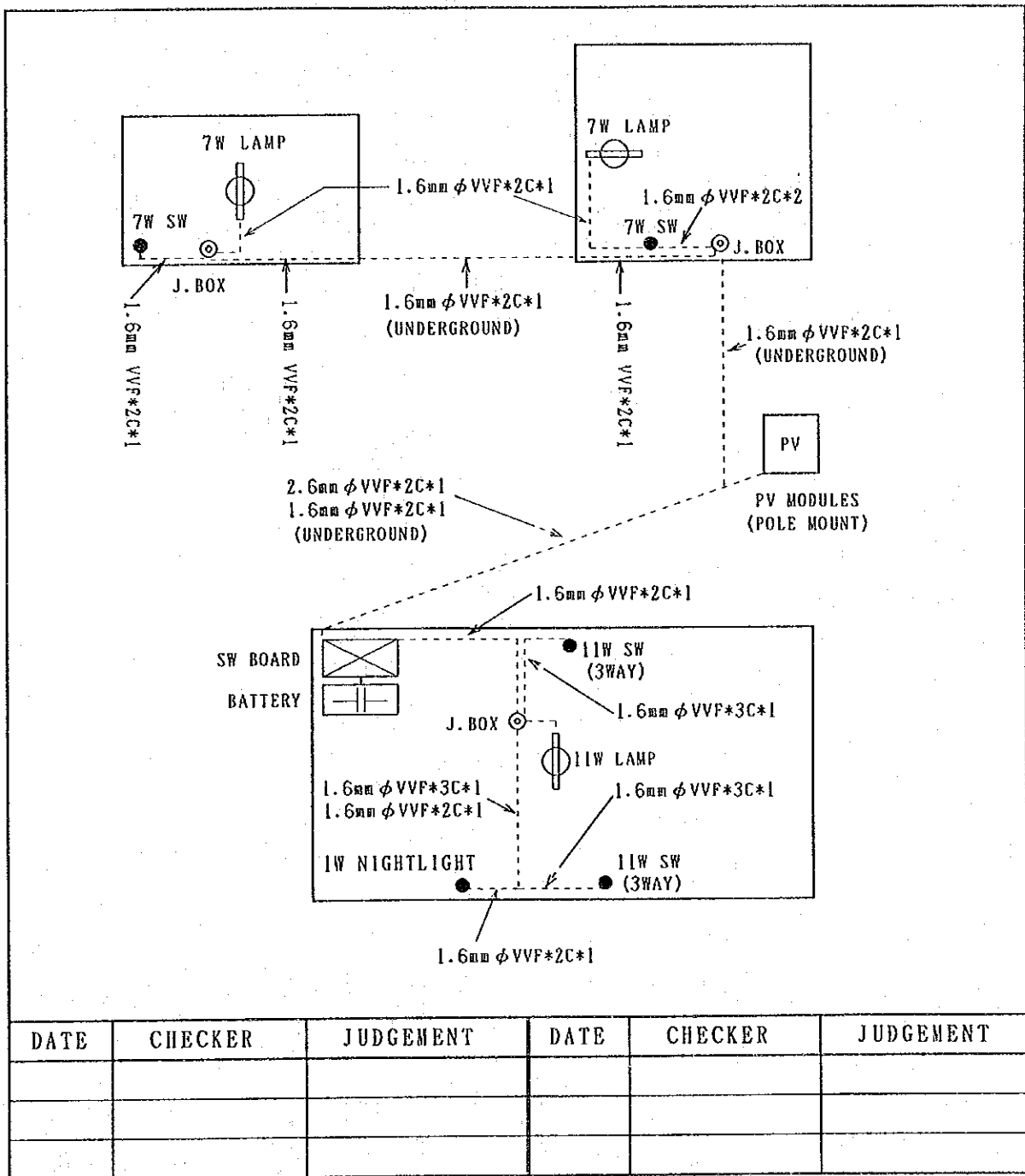

DATE	CHECKER	JUDGEMENT	DATE	CHECKER	JUDGEMENT

5. List of main equipment

No	Equipment Item	Quantity	No	Equipment Item	Quantity
1	PV Module	2 pcs	8	1W LED night light	1 ea
2	Pole Mount	1 set	9	No Fuse Braker(10(A))	1 ea
3	Charge Controller	1 ea	10	Main switch(30(A))	3 ea
4	Battery(12V-100Ah)	1 ea	11	Protection Fuse(15(A))	1 ea
5	Battery Box	1 ea	12	Junction Box	3 pcs
6	Fluorescent Lamp(11w)	1 ea	13	Switch(7(W))	2 pcs
7	Fluorescent Lamp(7w)	2 pcs	14	3way switch(11(W))	2 pcs

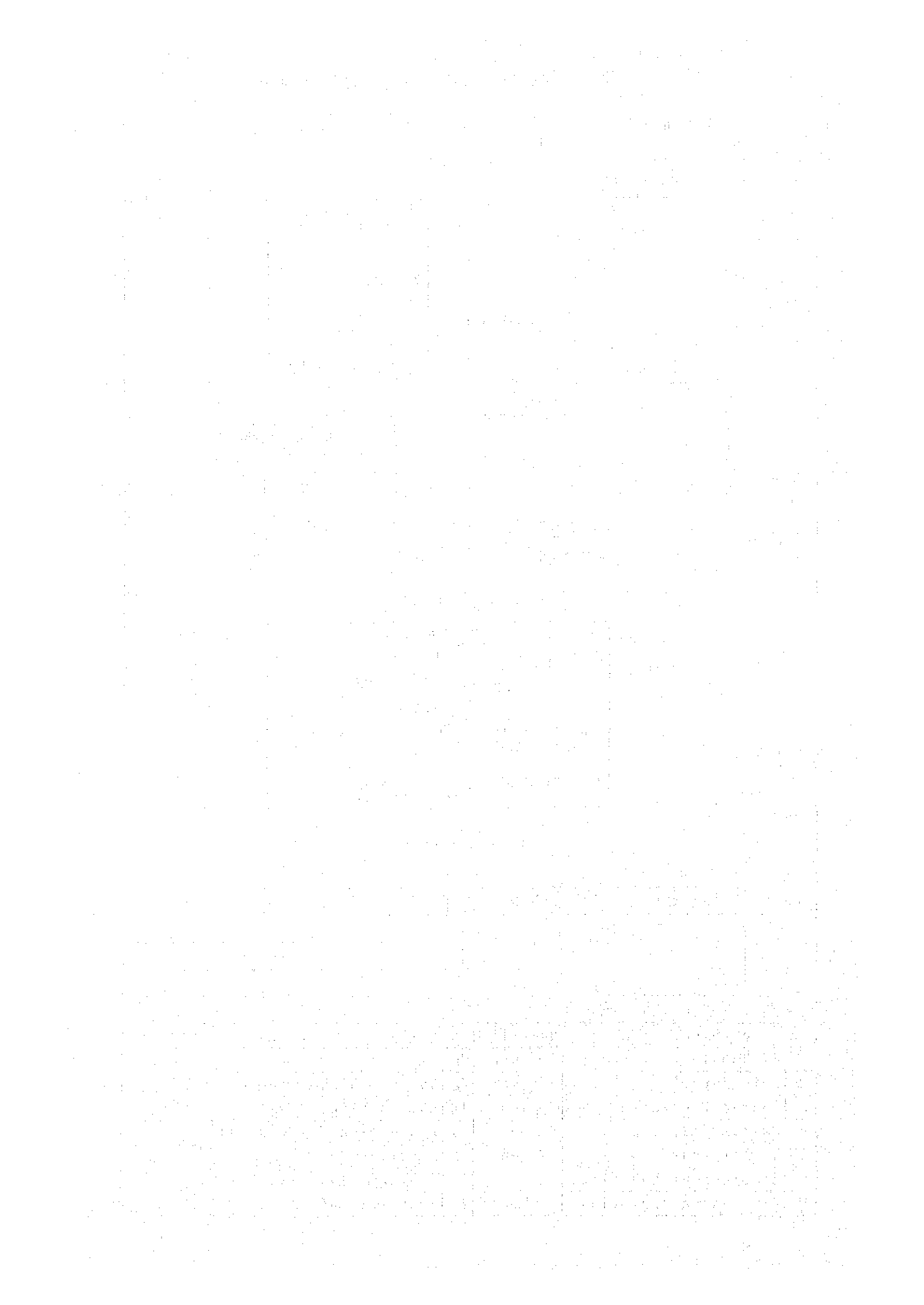

File of PV system Facility for Private House

1. Name of householder : M o a u e a .
2. Code NO : M 4
3. Name of village : M a r e n a n u k a
4. Drawing of PV Facility

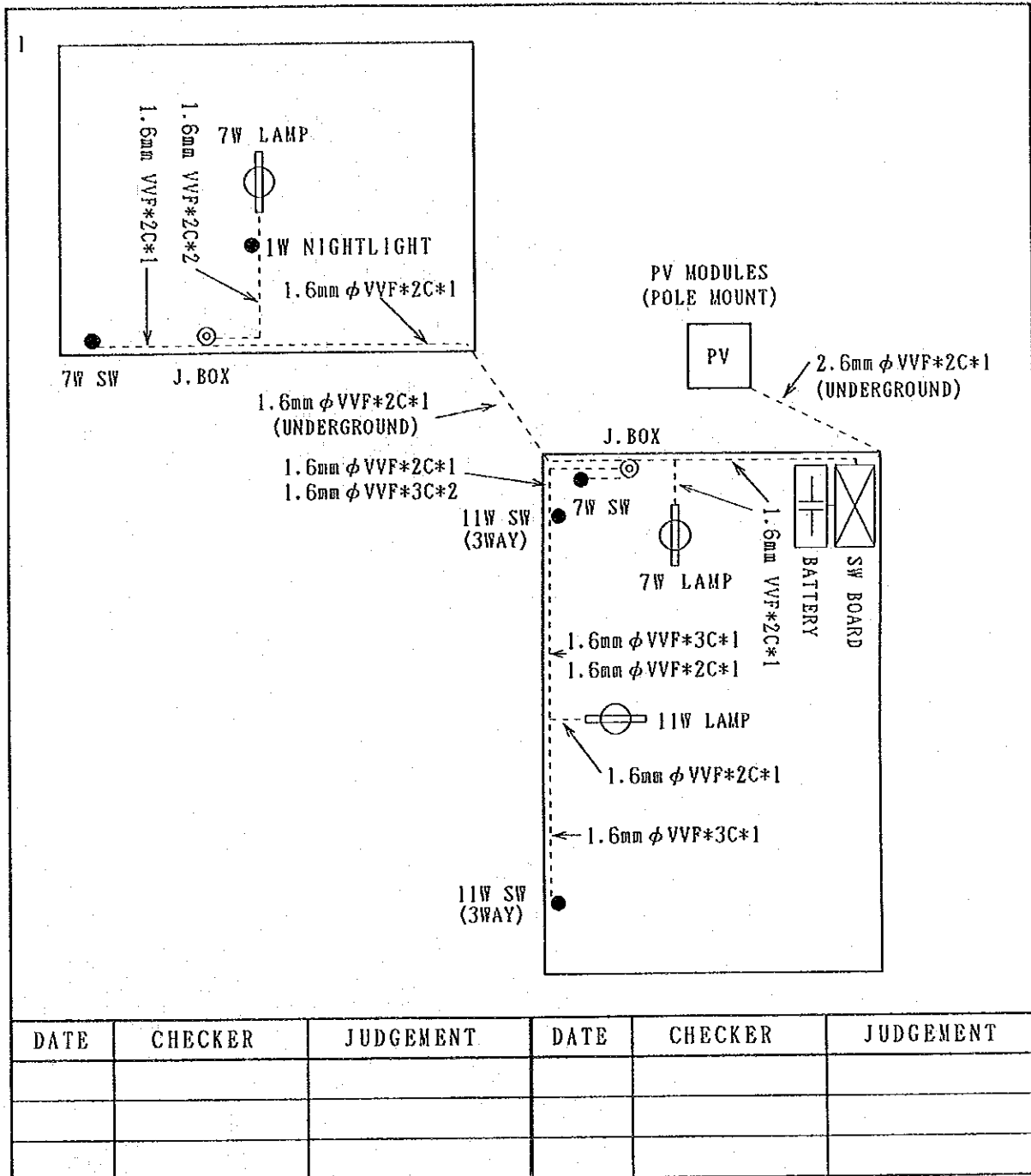

5. List of main equipment

Equipment Item	Quantity	Equipment Item	Quantity
1 PV Module	2 pcs	8 1W LED night light	1 ea
2 Pole Mount	1 set	9 No Fuse Braker(10(A))	1 ea
3 Charge Controller	1 ea	10 Main switch(30(A))	3 ea
4 Battery(12V-100Ah)	1 ea	11 Protection Fuse(15(A))	1 ea
5 Battery Box	1 ea	12 Junction Box	3 pcs
6 Fluorescent Lamp(11w)	1 ea	13 Switch(7(W))	2 pcs
7 Fluorescent Lamp(7w)	2 pcs	14 3Way switch(11(W))	2 pcs

File of PV system Facility for Private House

1. Name of householder : Ten T a t e r a k a
2. Code NO : M 7
3. Name of village : M a r e n a n u k a
4. Drawing of PV Facility

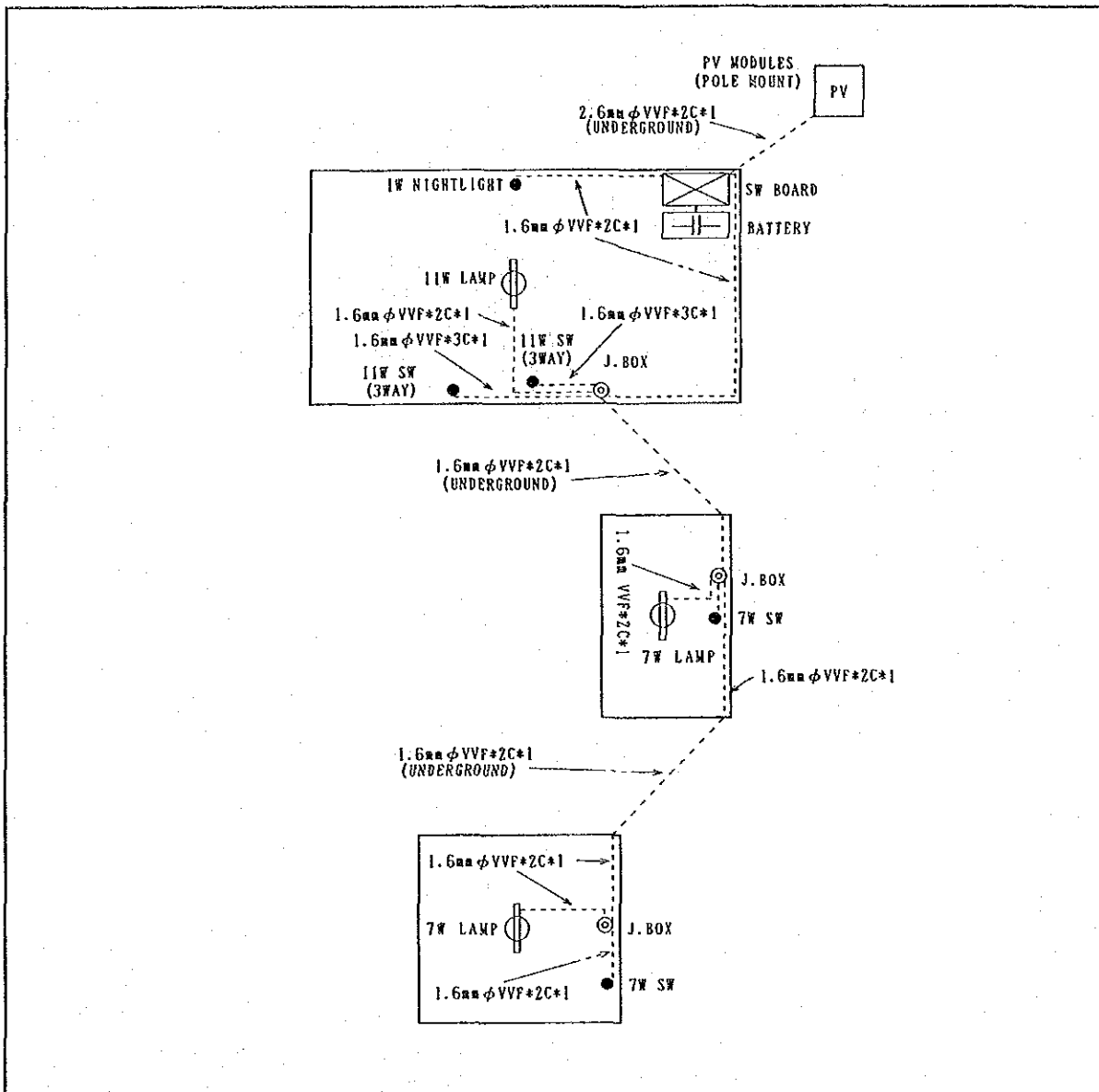

DATE	CHECKER	JUDGEMENT	DATE	CHECKER	JUDGEMENT

5. List of main equipment

No	Equipment Item	Quantity	No	Equipment Item	Quantity
1	PV Module	2 pcs	8	1W LED night light	1 ea
2	Pole Mount	1 set	9	No Fuse Braker(10(A))	1 ea
3	Charge Controller	1 ea	10	Main switch(30(A))	3 ea
4	Battery(12V-100Ah)	1 ea	11	Protection Fuse(15(A))	1 ea
5	Battery Box	1 ea	12	Junction Box	3 pcs
6	Fluorescent Lamp(11w)	1 ea	13	Switch(7(W))	2 pcs
7	Fluorescent Lamp(7w)	2 pcs	14	3Way switch(11(W))	2 pcs

File of PV system Facility for Private House

1. Name of householder : R a b a n g a k i M a t i m a r a
2. Code NO : T 6
3. Name of village : T a b o n i b a r a
4. Drawing of PV Facility

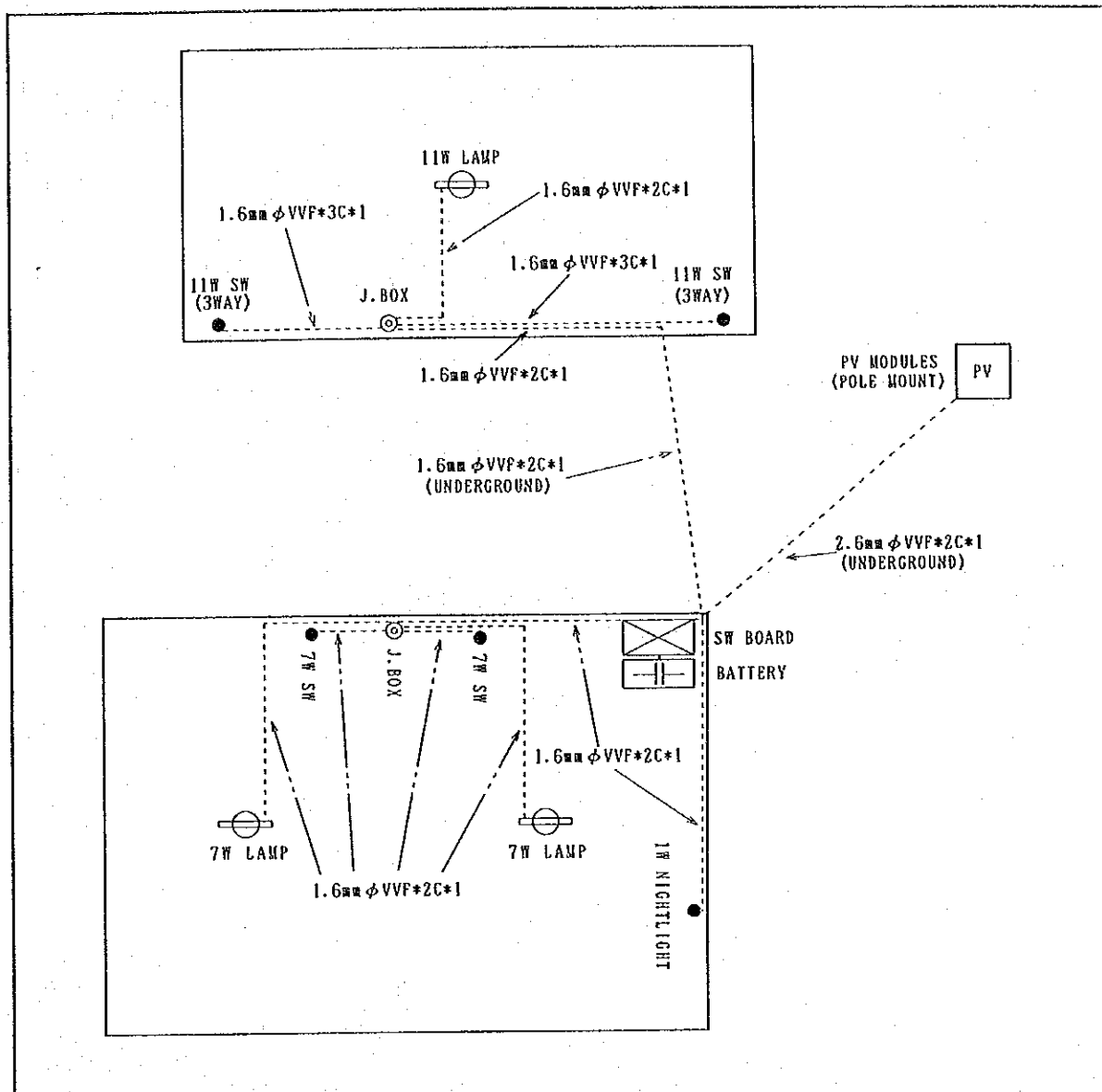

DATE	CHECKER	JUDGEMENT	DATE	CHECKER	JUDGEMENT

5. List of main equipment

No	Equipment Item	Quantity	No	Equipment Item	Quantity
1	PV Module	2 pcs	8	1W LED night light	1 ea
2	Pole Mount	1 set	9	No Fuse Braker(10(A))	1 ea
3	Charge Controller	1 ea	10	Main switch(30(A))	3 ea
4	Battery(12V-100Ah)	1 ea	11	Protection Fuse(15(A))	1 ea
5	Battery Box	1 ea	12	Junction Box	3 pcs
6	Fluorescent Lamp(11w)	1 ea	13	Switch(7(W))	2 pcs
7	Fluorescent Lamp(7w)	2 pcs	14	3Way switch(11(W))	2 pcs

File of PV system Facility for Private House

1. Name of householder : T o a n i T a k a i o
2. Code NO : T 1 8
3. Name of village : T a b o n i b a r a
4. Drawing of PV Facility

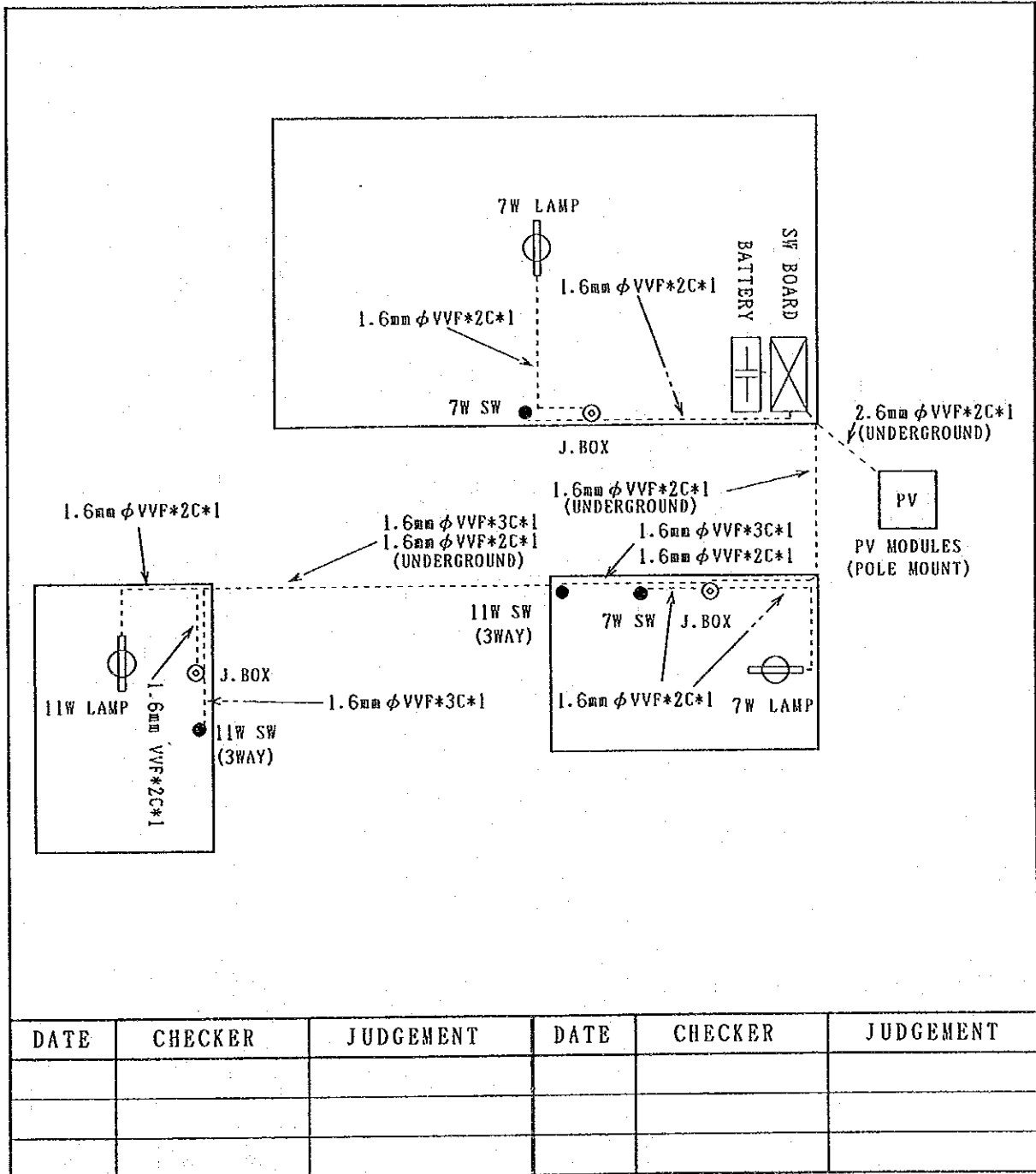

5. List of main equipment

Equipment Item	Quantity	Equipment Item	Quantity
1 PV Module	2 pcs	8 1W LED night light	1 ea
2 Pole Mount	1 set	9 No Fuse Braker(10(A))	1 ea
3 Charge Controller	1 ea	10 Main switch(30(A))	3 ea
4 Battery(12V-100Ah)	1 ea	11 Protection Fuse(15(A))	1 ea
5 Battery Box	1 ea	12 Junction Box	3 pcs
6 Fluorescent Lamp(11w)	1 ea	13 Switch(7(W))	2 pcs
7 Fluorescent Lamp(7w)	2 pcs	14 3Way switch(11(W))	2 pcs

File of PV system Facility for Private House

1. Name of householder : Teaoti Ngoia
2. Code NO : T 2 3
3. Name of village : Tabonibara
4. Drawing of PV Facility

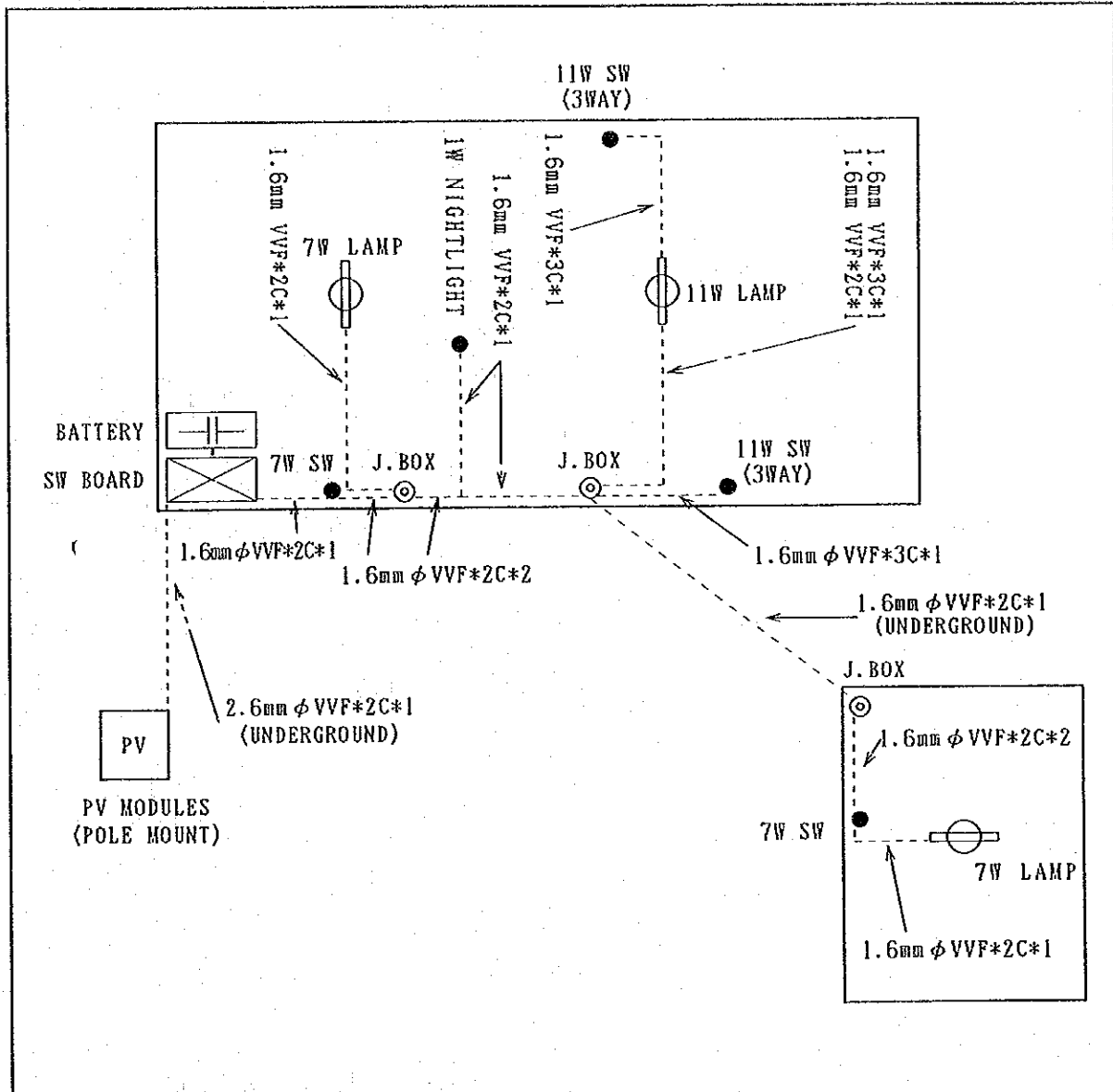

DATE	CHECKER	JUDGEMENT	DATE	CHECKER	JUDGEMENT

5. List of main equipment

Equipment Item	Quantity	Equipment Item	Quantity
1 PV Module	2 pcs	8 1W LED night light	1 ea
2 Pole Mount	1 set	9 No Fuse Braker(10(A))	1 ea
3 Charge Controller	1 ea	10 Main switch(30(A))	3 ea
4 Battery(12V-100Ah)	1 ea	11 Protection Fuse(15(A))	1 ea
5 Battery Box	1 ea	12 Junction Box	3 pcs
6 Fluorescent Lamp(11w)	1 ea	13 Switch(7(W))	2 pcs
7 Fluorescent Lamp(7w)	2 pcs	14 3way switch(11(W))	2 pcs

File of PV system Facility for Private House

1. Name of householder : M a e u e a
2. Code NO :
3. Name of village : T a b o n i b a r a
4. Drawing of PV Facility

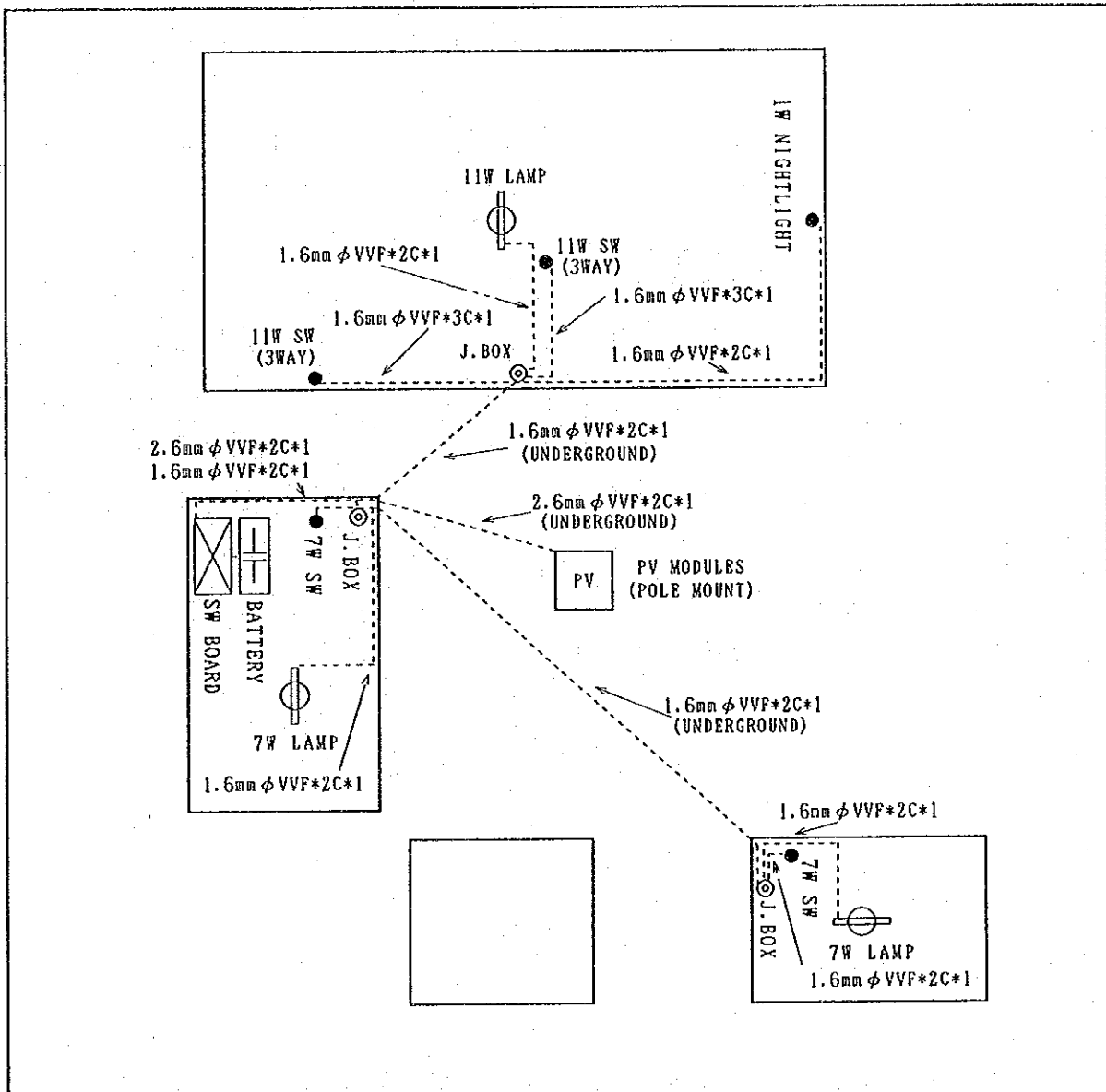

DATE	CHECKER	JUDGEMENT	DATE	CHECKER	JUDGEMENT

5. List of main equipment

No	Equipment Item	Quantity	No	Equipment Item	Quantity
1	PV Module	2 pcs	8	1W LED night light	1 ea
2	Pole Mount	1 set	9	No Fuse Braker(10(A))	1 ea
3	Charge Controller	1 ea	10	Main switch(30(A))	3 ea
4	Battery(12V-100Ah)	1 ea	11	Protection Fuse(15(A))	1 ea
5	Battery Box	1 ea	12	Junction Box	3 pcs
6	Fluorescent Lamp(11w)	1 ea	13	Switch(7(W))	2 pcs
7	Fluorescent Lamp(7w)	2 pcs	14	3way switch(11(W))	2 pcs

File of PV system Facility for Private House

1. Name of householder : T a b e i a
2. Code NO :
3. Name of village : T a b o n i b a r a
4. Drawing of PV Facility

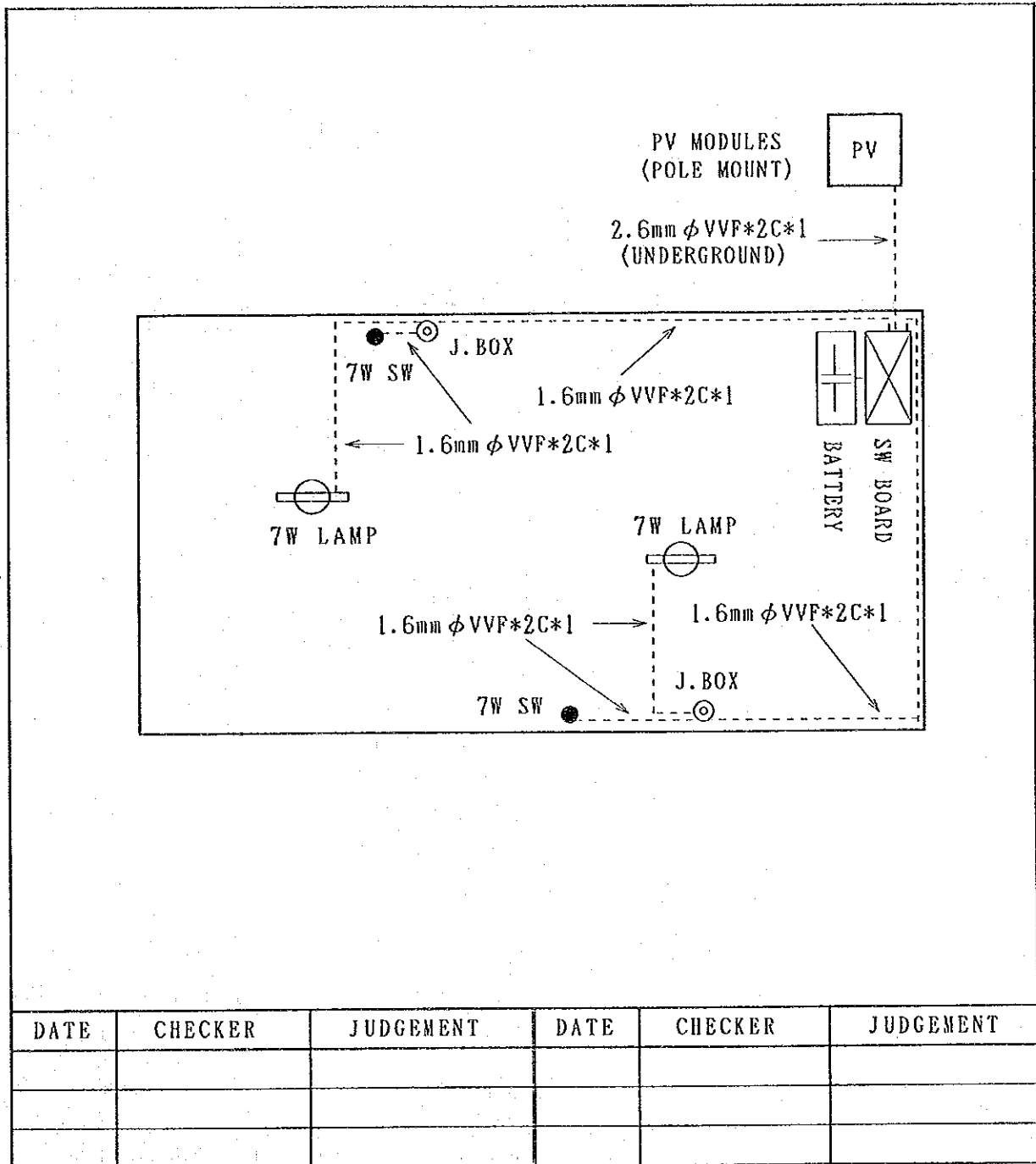

DATE	CHECKER	JUDGEMENT	DATE	CHECKER	JUDGEMENT

5. List of main equipment

	Equipment Item	Quantity		Equipment Item	Quantity
1	PV Module	2 pcs	8	1W LED night light	1 ea
2	Pole Mount	1 set	9	No Fuse Braker(10(A))	1 ea
3	Charge Controller	1 ea	10	Main switch(30(A))	3 ea
4	Battery(12V-100Ah)	1 ea	11	Protection Fuse(15(A))	1 ea
5	Battery Box	1 ea	12	Junction Box	2 pcs
6	Fluorescent Lamp(11w)	ea	13	Switch(7(W))	2 pcs
7	Fluorescent Lamp(7w)	2 pcs	14	3Way switch(11(W))	pcs

File of PV system Facility for Private House

1. Name of householder : T u t u T i r i b o
2. Code NO :
3. Name of village : T a b o n i b a r a
4. Drawing of PV Facility

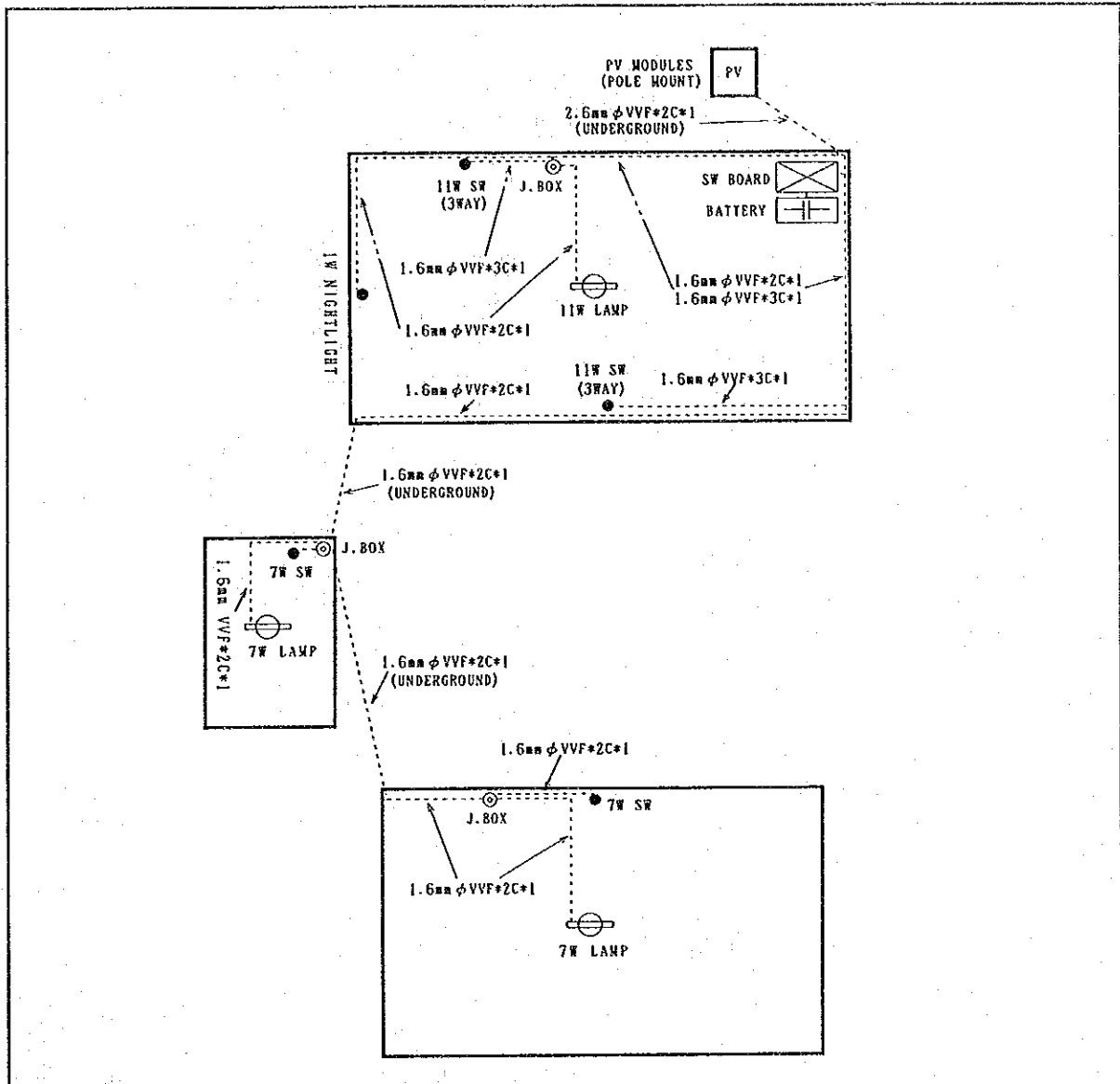

DATE	CHECKER	JUDGEMENT	DATE	CHECKER	JUDGEMENT

5. List of main equipment

Equipment Item	Quantity	Equipment Item	Quantity
1 PV Module	2 pcs	8 1W LED night light	1 ea
2 Pole Mount	1 set	9 No Fuse Braker(10(A))	1 ea
3 Charge Controller	1 ea	10 Main switch(30(A))	3 ea
4 Battery(12V-100Ah)	1 ea	11 Protection Fuse(15(A))	1 ea
5 Battery Box	1 ea	12 Junction Box	3 pcs
6 Fluorescent Lamp(11w)	1 ea	13 Switch(7(W))	2 pcs
7 Fluorescent Lamp(7w)	2 pcs	14 3Way switch(11(W))	2 pcs

File of PV system Facility for Private House

1. Name of householder : B i r i k a u a T a b o k a i
2. Code NO : K 4
3. Name of village : K a i n a b a
4. Drawing of PV Facility

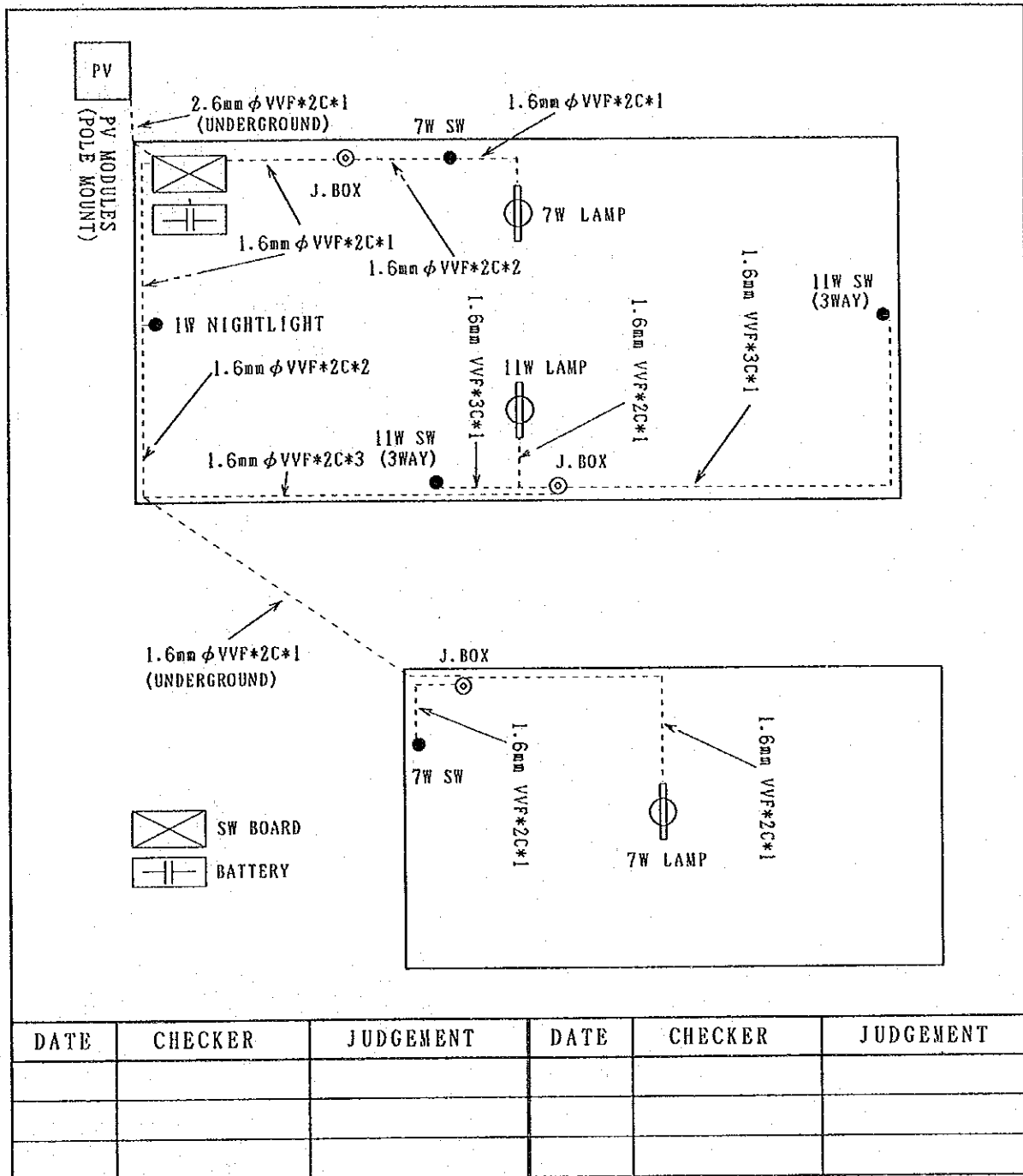

DATE	CHECKER	JUDGEMENT	DATE	CHECKER	JUDGEMENT

5. List of main equipment

No	Equipment Item	Quantity	No	Equipment Item	Quantity
1	PV Module	2 pcs	8	1W LED night light	1 ea
2	Pole Mount	1 set	9	No Fuse Braker(10(A))	1 ea
3	Charge Controller	1 ea	10	Main switch(30(A))	3 ea
4	Battery(12V-100Ah)	1 ea	11	Protection Fuse(15(A))	1 ea
5	Battery Box	1 ea	12	Junction Box	3 pcs
6	Fluorescent Lamp(11w)	1 ea	13	Switch(7(W))	2 pcs
7	Fluorescent Lamp(7w)	2 pcs	14	3Way switch(11(W))	2 pcs

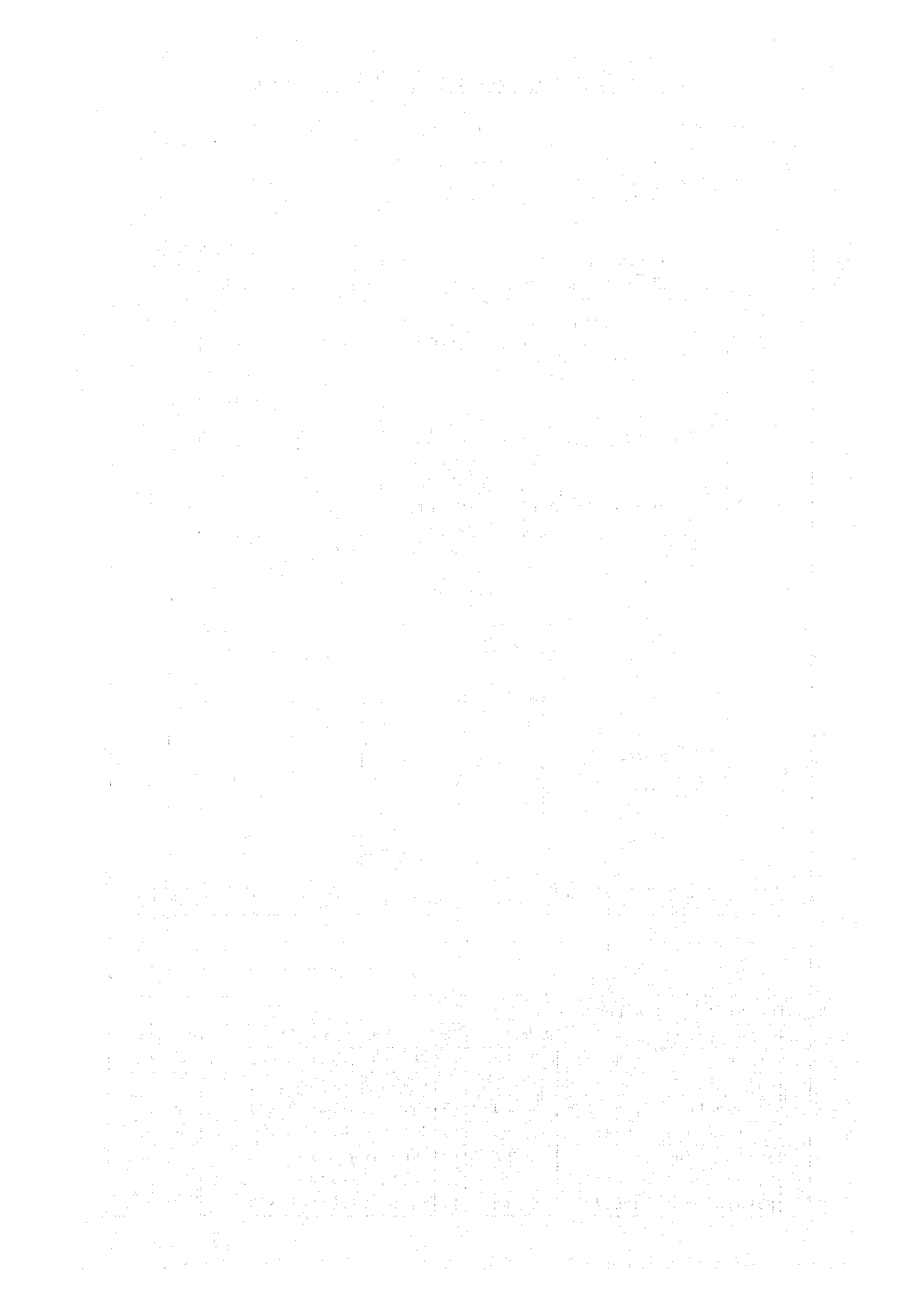

File of PV system Facility for Private House

1. Name of householder : T a a k e T e t a u a
2. Code NO : K 1 0
3. Name of village : K a i n a b a
4. Drawing of PV Facility

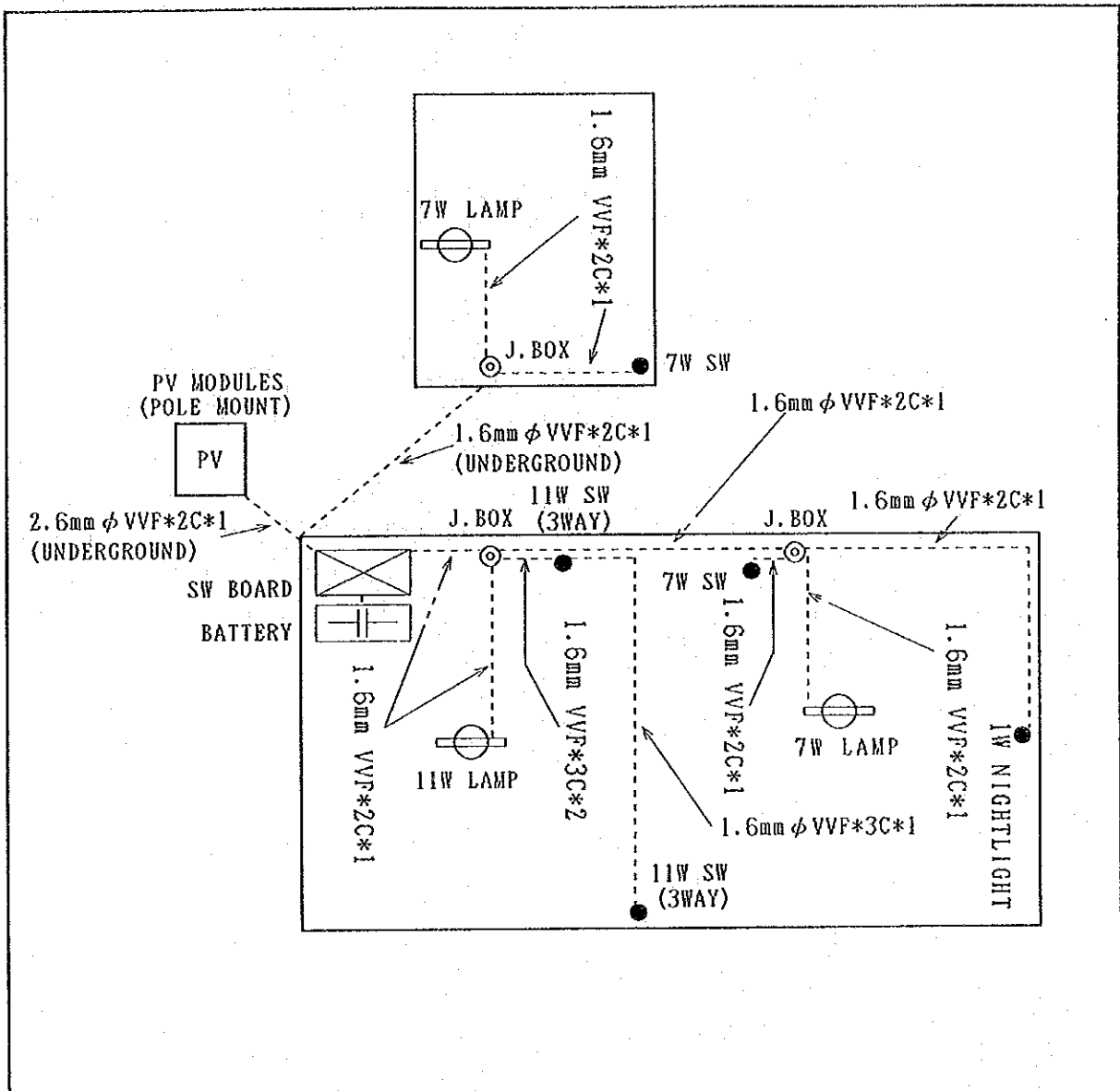

DATE	CHECKER	JUDGEMENT	DATE	CHECKER	JUDGEMENT

5. List of main equipment

No	Equipment Item	Quantity	No	Equipment Item	Quantity
1	PV Module	2 pcs	8	1W LED night light	1 ea
2	Pole Mount	1 set	9	No Fuse Braker(10(A))	1 ea
3	Charge Controller	1 ea	10	Main switch(30(A))	3 ea
4	Battery(12V-100Ah)	1 ea	11	Protection Fuse(15(A))	1 ea
5	Battery Box	1 ea	12	Junction Box	3 pcs
6	Fluorescent Lamp(11w)	1 ea	13	Switch(7(W))	2 pcs
7	Fluorescent Lamp(7w)	2 pcs	14	3Way switch(11(W))	2 pcs

File of PV system Facility for Private House

1. Name of householder : Te bu a t e i A b i e t e
2. Code NO : K 1 1
3. Name of village : K a i n a b a
4. Drawing of PV Facility

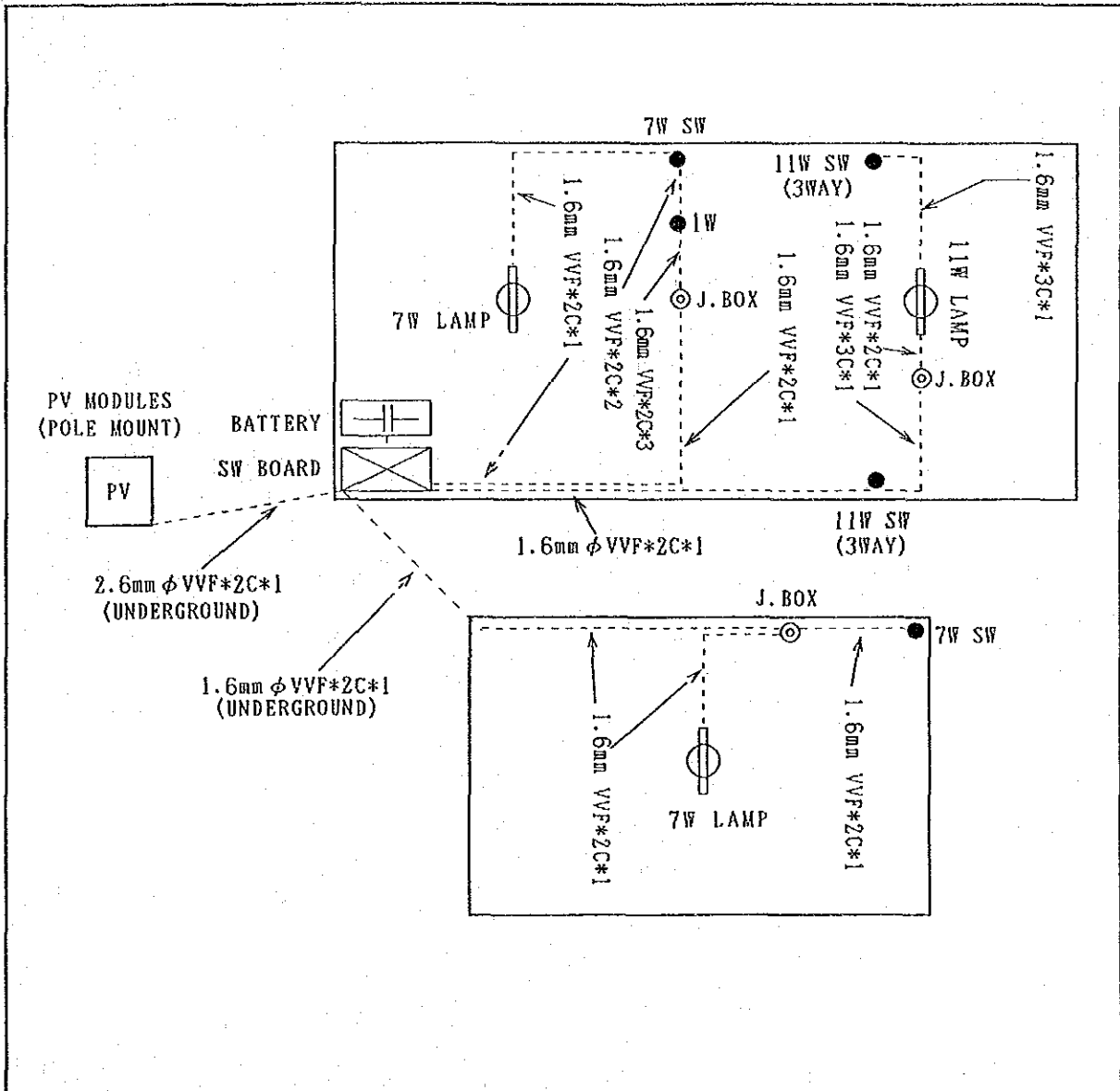

DATE	CHECKER	JUDGEMENT	DATE	CHECKER	JUDGEMENT

5. List of main equipment

No	Equipment Item	Quantity	No	Equipment Item	Quantity
1	PV Module	2 pcs	8	1W LED night light	1 ea
2	Pole Mount	1 set	9	No Fuse Braker(10(A))	1 ea
3	Charge Controller	1 ea	10	Main switch(30(A))	3 ea
4	Battery(12V-100Ah)	1 ea	11	Protection Fuse(15(A))	1 ea
5	Battery Box	1 ea	12	Junction Box	3 pcs
6	Fluorescent Lamp(11w)	1 ea	13	Switch(7(W))	2 pcs
7	Fluorescent Lamp(7w)	2 pcs	14	3way switch(11(W))	2 pcs

File of PV system Facility for Private House

1. Name of householder : U e a n n a T e m a n i k a a i
2. Code NO : K 1 4
3. Name of village : K a i n a b a
4. Drawing of PV Facility

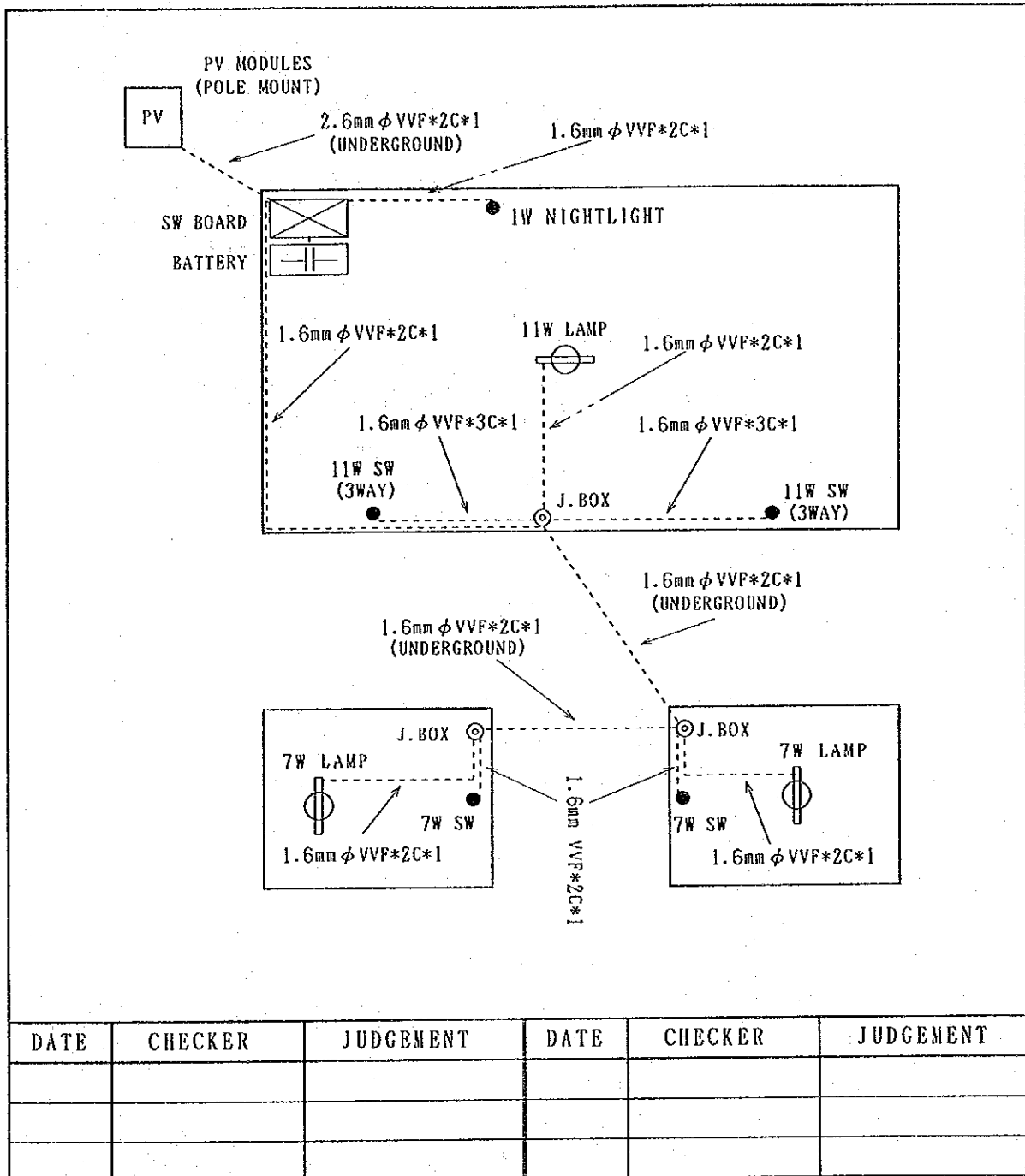

DATE	CHECKER	JUDGEMENT	DATE	CHECKER	JUDGEMENT

5. List of main equipment

	Equipment Item	Quantity		Equipment Item	Quantity
1	PV Module	2 pcs	8	1W LED night light	1 ea
2	Pole Mount	1 set	9	No Fuse Braker(10(A))	1 ea
3	Charge Controller	1 ea	10	Main switch(30(A))	3 ea
4	Battery(12V-100Ah)	1 ea	11	Protection Fuse(15(A))	1 ea
5	Battery Box	1 ea	12	Junction Box	3 pcs
6	Fluorescent Lamp(11w)	1 ea	13	Switch(7(W))	2 pcs
7	Fluorescent Lamp(7w)	2 pcs	14	3way switch(11(W))	2 pcs

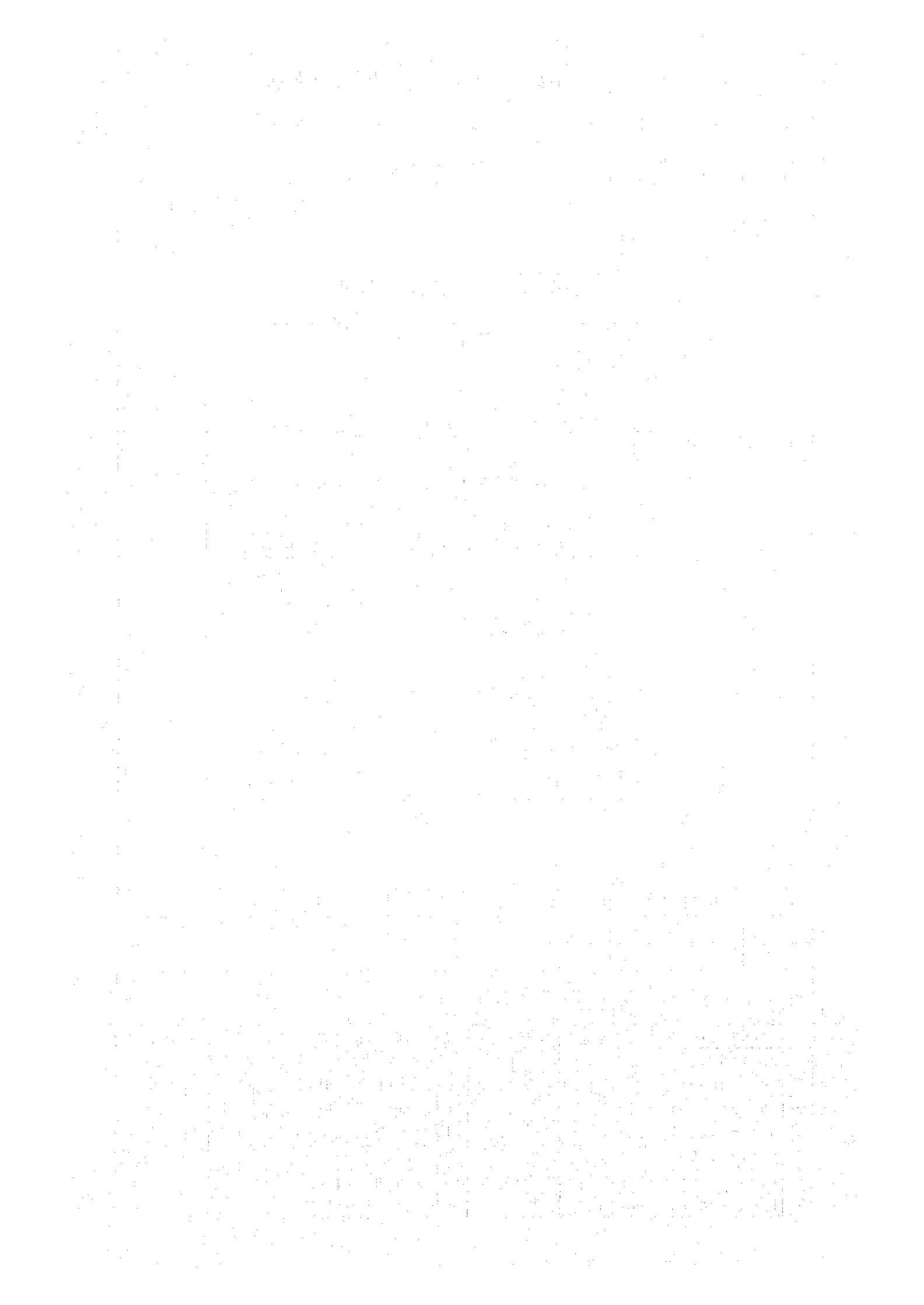

JICA

