

THE DETAILED DESIGN STUDY ON THE NAIROBI BYPASS PROJECT

SHEET NO. 32

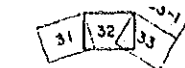

INDEX TO ADJOINING SHEETS

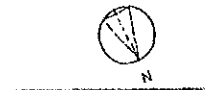
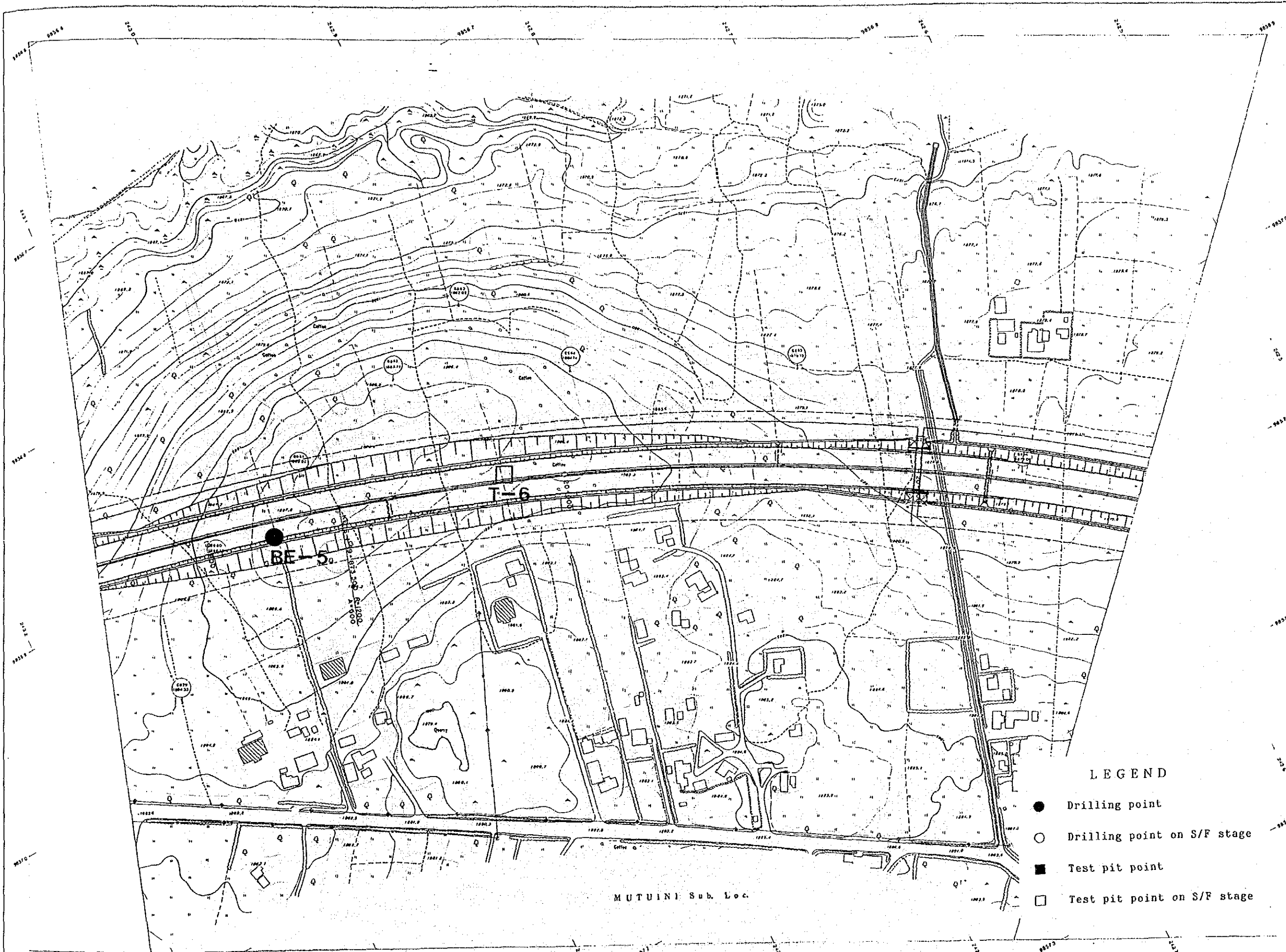

Scale 1:2,000
HEIGHTS IN METERS

LEGEND

	GTS Point
	Traverse Point
	Bench Mark
	Direct Leveling He
	Spot Height
	Contours (V.L. 1m)
	Outcrop (Rock)
	Building, Permanent
	Building, Others
	Paved Road
	Road
	Track
	Railway
	Bridge, Culvert
	River
	Stream
	Dam
	Pond
	Water Tank
	Power Line
	Telephone Line
	Fence, Gate
	Hedge
	Stone Wall
	Dump or Stroud
	Quarry Pit
	Cusine
	Embankment
	Cultivated Land
	Orchard or Permanent
	Plantation
	Grassland
	Bush
	Forest
	Swamp
	Vegetation Boundary
	Plastric Partition

HORIZONTAL DATUM: UTM ZONE 3
CLARKE 1866 SPI

VERTICAL DATUM: MEAN SEA LE

AERIAL PHOTOGRAPHY BY
Japan International Cooperation
Agency

GROUND CONTROL SURVEYED BY
Occom

STEREO PLOTTED BY
MAR

CARTOGRAPHY BY
JI

CHIEF ENGINEER
DATE

CHIEF SUPT. ENG.
DATE

CHECKED BY
SEN SUPT. ENG.
DATE

SUPT. ENGINEER
DATE

PROJECT ENGINEER
DATE

MINISTRY OF PUBLIC
WORKS

M.O.P.W.

OFFICE OF ORIGIN
JICA TOKYO, JAP.

SHEET 32 OF 46

LEGEND

	Drilling point
	Drilling point on S/F stage
	Test pit point
	Test pit point on S/F stage

DETAILED LOCATION MAP OF GEOLOGICAL SURVEY

THE DETAILED DESIGN STUDY ON THE NAIROBI BYPASS PROJECT

SHEET NO. 33

33 34

INDEX TO ADJOINING SHEET

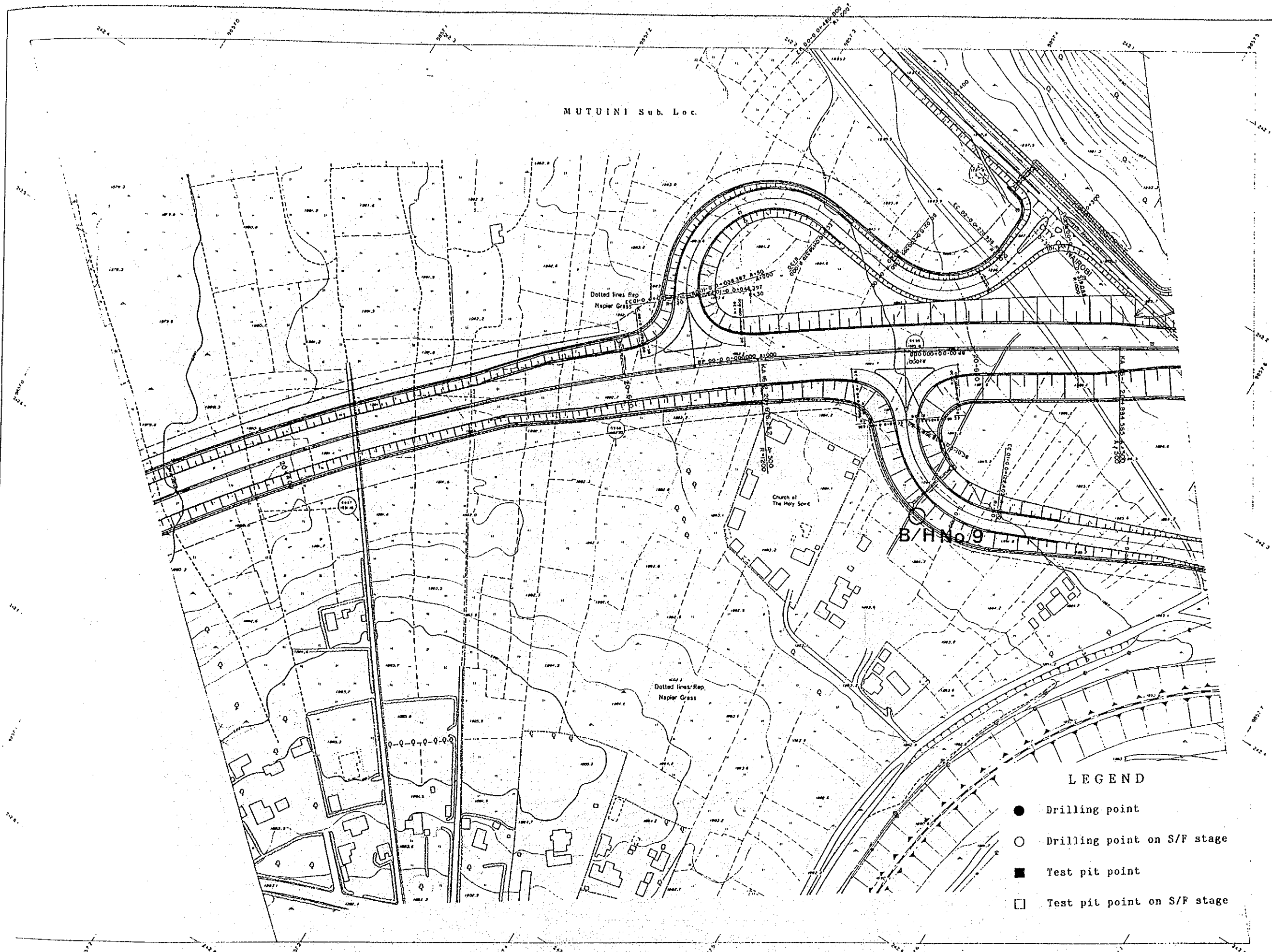

DETAILED LOCATION MAP OF GEOLOGICAL SURVEY

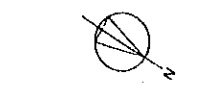

Scale 1:2,000
HEIGHTS IN METERS

LEGEND

- △ GPS Point
- Traverse Point
- ⊙ Bench Mark
- 1234.5 Direct Leveling Height
- 123.4 Spot Height
- Contours (V.L. Int)
- Outcrop (Rock)
- ▭ Building, Permanent
- ▭ Building, Others
- ▭ Bituminous Road
- ▭ Road
- ▭ Track
- ▭ Railway
- ▭ Ridge, Culvert
- ▭ River
- ▭ Stream
- ▭ Dam
- ▭ Flood
- ▭ Water Tank
- ▭ Power Line
- ▭ Telephone Line
- ▭ Fence, Gate
- ▭ Hedge
- ▭ Stone Wall
- ▭ Dump or Mound
- ▭ Quarry, Pit
- ▭ Cutting
- ▭ Embankment
- ▭ Cultivated Lands
- ▭ Orchard or Permanent
- ▭ Plantation
- ▭ Grassland
- ▭ Bush
- ▭ Forest
- ▭ Swamp
- ▭ Vegetation Boundary
- ▭ Planting Partition

LEGEND

- Drilling point
- Drilling point on S/F stage
- Test pit point
- Test pit point on S/F stage

HORIZONTAL DATUM UTM ZONE 37
CLARKE 1866 SPIII

VERTICAL DATUM MEAN SEA LEA

AERIAL PHOTOGRAPHY BY
Japan International Cooperation /
Decemb

GROUND CONTROL SURVEYED BY
Decemb

STEREO PLOTTED BY
MARU

CARTOGRAPHY BY
JUL

CHIEF ENGINEER /
DATE /

CHIEF SUPT. ENG. /
DATE /

CHECKED BY SEN. SUPT. ENG. /
DATE /

DATE /

PROJECT ENGINEER /
DATE /

DATE /

MINISTRY OF PUBLIC WORKS

M.O.P.W.

OFFICE OF ORIGIN

JICA TOKYO, JAPAN

SHEET 33 OF 46

THE DETAILED DESIGN STUDY ON THE NAIROBI BYPASS PROJECT

SHEET NO. 34

33 / 34 / 35

INDEX TO ADJOINING SHEETS

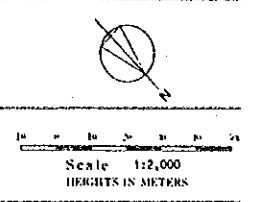
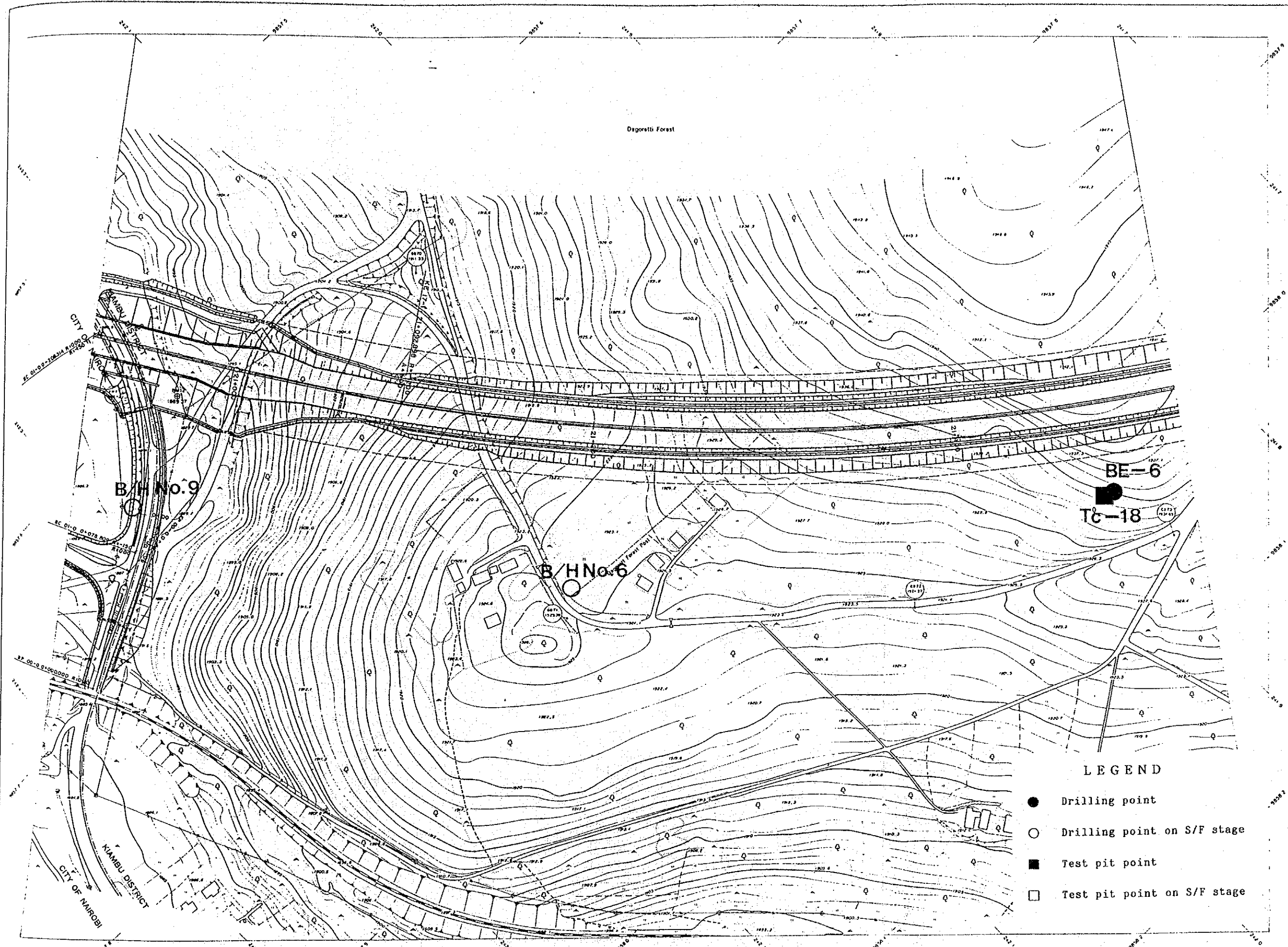

LEGEND

	GPS Point
	Traverse Point
	Bench Mark
	Direct Leveling Height
	Spot Height
	Contours V.L. line
	Outcrop (Rock)
	Building, Permanent
	Building, Other
	Bituminous Road
	Road
	Track
	Railway
	Bridge, Culvert
	River
	Stream
	Dam
	Pond
	Water Tank
	Power Line
	Telephone Line
	Fence, Gate
	Hedge
	Stone Wall
	Dune or Mound
	Quarry, Pit
	Cutting
	Embankment
	Cultivated Lands
	Orchard or Permanent Crop
	Plantation
	Grassland
	Bush
	Forest
	Swamp
	Vegetation Boundary
	Planting Partition

HORIZONTAL DATUM: UTM ZONE 37
CLARKE 1866 SPHEROID

VERTICAL DATUM: MEAN SEA LEVEL

AERIAL PHOTOGRAPHY BY: JICA
Japan International Cooperation Agency
December 1

GROUND CONTROL SURVEYED BY: JICA
December 1

STEREO PLOTTED BY: JICA
MARCH 1

CARTOGRAPHY BY: JICA
JULY 1

CHEF ENGINEER: ORUA
DATE: / /

CHEF SUPT. ENG: OESH
DATE: / /

CHECKED BY: SEN SUPT. ENG: OESH
DATE: / /

SUPT. ENGINEER: OESH
DATE: / /

PROJECT ENGINEER: / /

MINISTRY OF PUBLIC WORKS

M.O.P.W.

OFFICE OF ORIGIN
JICA TOKYO, JAPAN

SHEET 34 OF 46

LEGEND

	Drilling point
	Drilling point on S/F stage
	Test pit point
	Test pit point on S/F stage

DETAILED LOCATION MAP OF GEOLOGICAL SURVEY

THE DETAILED DESIGN STUDY ON THE NAIROBI BYPASS PROJECT

SHEET NO. 35

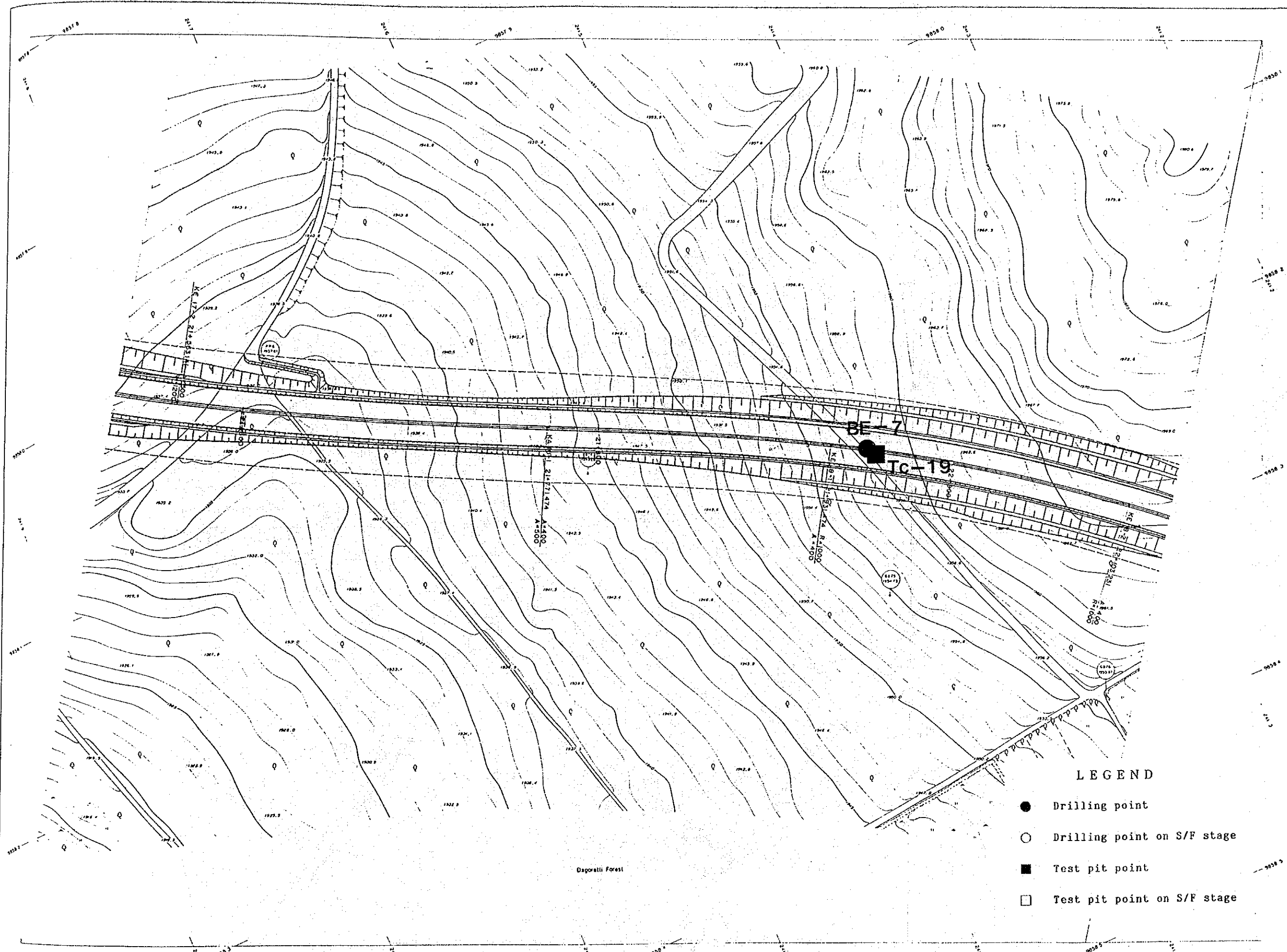
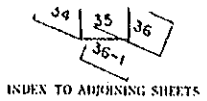

Scale 1:7,000
HEIGHTS IN METERS

LEGEND	
	GPS Point
	Traverse Point
	Bench Mark
	Direct Leveling Height
	Spot Height
	Contours (V.L. Int.)
	Outcrop (Rock)
	Building (Permanent)
	Building (Others)
	Bituminous Road
	Road
	Track
	Railway
	Inlet, Culvert
	River
	Stream
	Dam
	Pond
	Water Tank
	Power Line
	Telephone Line
	Fence, Gate
	Hedge
	Stone Wall
	Dump or Mound
	Quarry, Pit
	Cutline
	Embankment
	Cultivated Lands
	Orchard or Permanent Cr.
	Plantation
	Graveland
	Bush
	Swamp
	Vegetation Boundary
	Planting Partition

HORIZONTAL DATUM: UTM ZONE 37
CLARKE 1866 SPHER.

VERTICAL DATUM: MEAN SEA LEVEL

AERIAL PHOTOGRAPHY BY: JICA
Japan International Cooperation Agency
December

GROUND CONTROL SURVEYED BY: JICA
December

STEREO PLOTTED BY: JICA
MARCH

CARTOGRAPHY BY: JICA
JICA

CHIEF ENGINEER: (Signature)
DATE: / /

CHIEF SUPT. ENG. (Signature)
DATE: / /

CHECKED BY: SEN. SUPT. ENG. (Signature)
DATE: / /

SUPT. ENGINEER (Signature)
DATE: / /

PROJECT ENGINEER (Signature)
DATE: / /

MINISTRY OF PUBLIC WORKS

M.O.P.W.

OFFICE OF ORIGIN
JICA TOKYO, JAPAN

SHEET 35 OF 46

LEGEND	
	Drilling point
	Drilling point on S/F stage
	Test pit point
	Test pit point on S/F stage

DETAILED LOCATION MAP OF GEOLOGICAL SURVEY

THE DETAILED DESIGN STUDY ON THE NAIROBI BYPASS PROJECT

SHEET NO. 36

35	36	37
36-1		37-2

INDEX TO ADJOINING SHEET

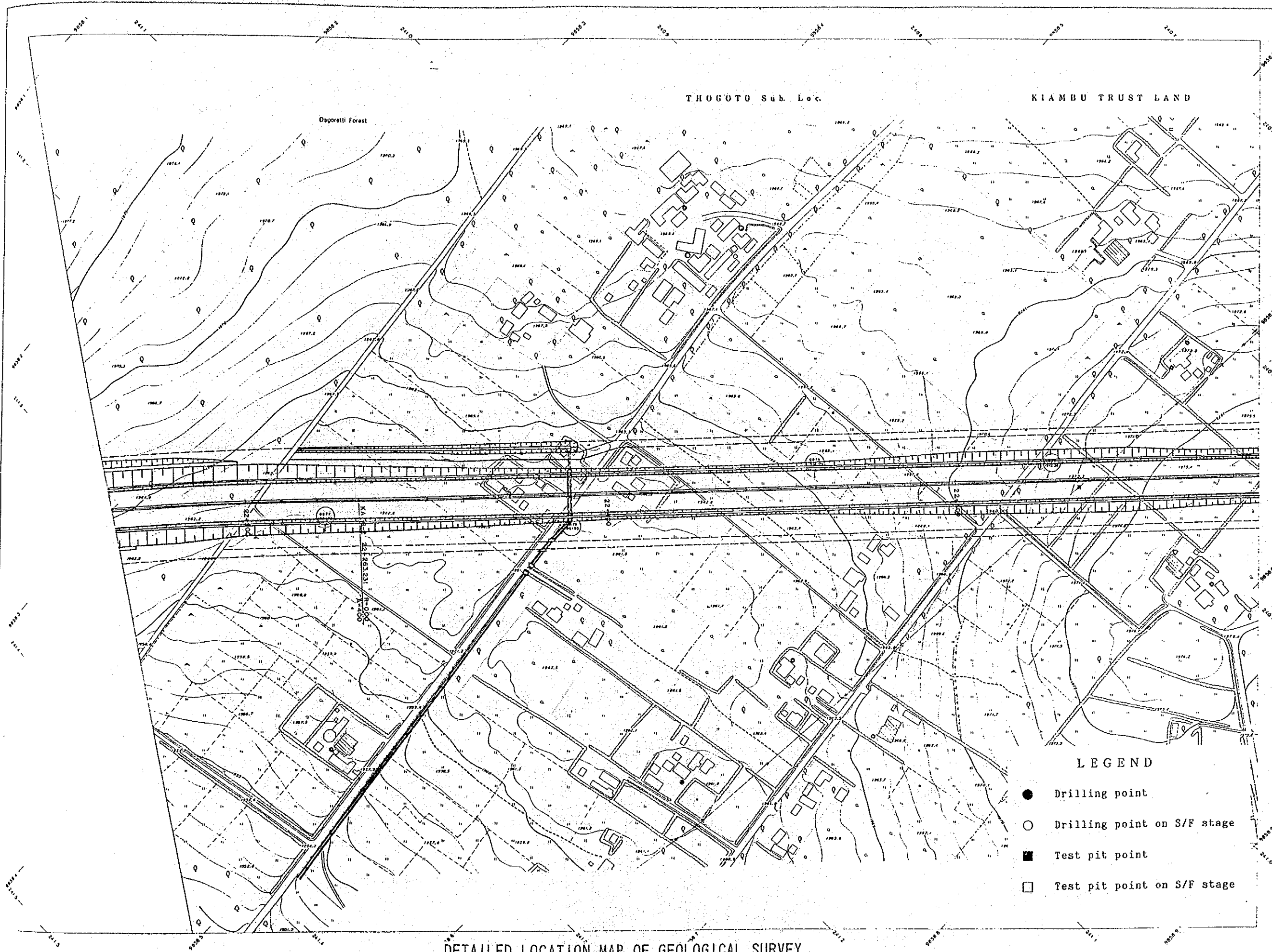

Scale 1:12,000
HEIGHTS IN METERS

LEGEND

- GPS Point
- Traverse Point
- Bench Mark
- Direct Leveling Height
- Spot Height
- Contours (V.L. 1m)
- Outcrop (Rock)
- Building Permanent
- Building Others
- Bituminous Road
- Road
- Track
- Railway
- Bridge, Culvert
- River
- Stream
- Dam
- Pond
- Water Tank
- Power Line
- Telephone Line
- Fence, Gate
- Hedge
- Stone Wall
- Dump or Mound
- Quarry, Pit
- Cutting
- Embankment
- Cultivated Lands
- Orchard or Perennial
- Plantation
- Grassland
- Bush
- Forest
- Swamp
- Vegetation Boundary
- Planning Partition

HORIZONTAL DATUM: UTM ZONE 35
CLARKE 1866 SPHEROID

VERTICAL DATUM: MEAN SEA LEVEL

AERIAL PHOTOGRAPHED BY:
Japan International Cooperation Agency
Decem 1961

GROUND CONTROL SURVEYED BY:
Decem 1961

STEREO PLOTTED BY:
MARU

CARTOGRAPHED BY:
JICA

LEGEND

- Drilling point
- Drilling point on S/F stage
- Test pit point
- Test pit point on S/F stage

CHEF ENGINEER	DATE
CHEF SUPT. ENG.	DATE
CHEF SUPT. ENG.	DATE
SUPT. ENGINEER	DATE
PROJECT ENGINEER	DATE

MINISTRY OF PUBLIC WORKS

M.O.P.W.

OFFICE OF ORIGIN
JICA TOKYO, JAPAN

SHEET 36 OF 46

DETAILED LOCATION MAP OF GEOLOGICAL SURVEY

THE DETAILED DESIGN STUDY ON THE NAIROBI BYPASS PROJECT

SHEET NO. 37

36 37 38
37-2
INDEX TO ADJOINING SHEET

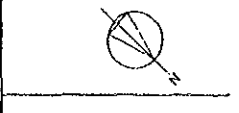
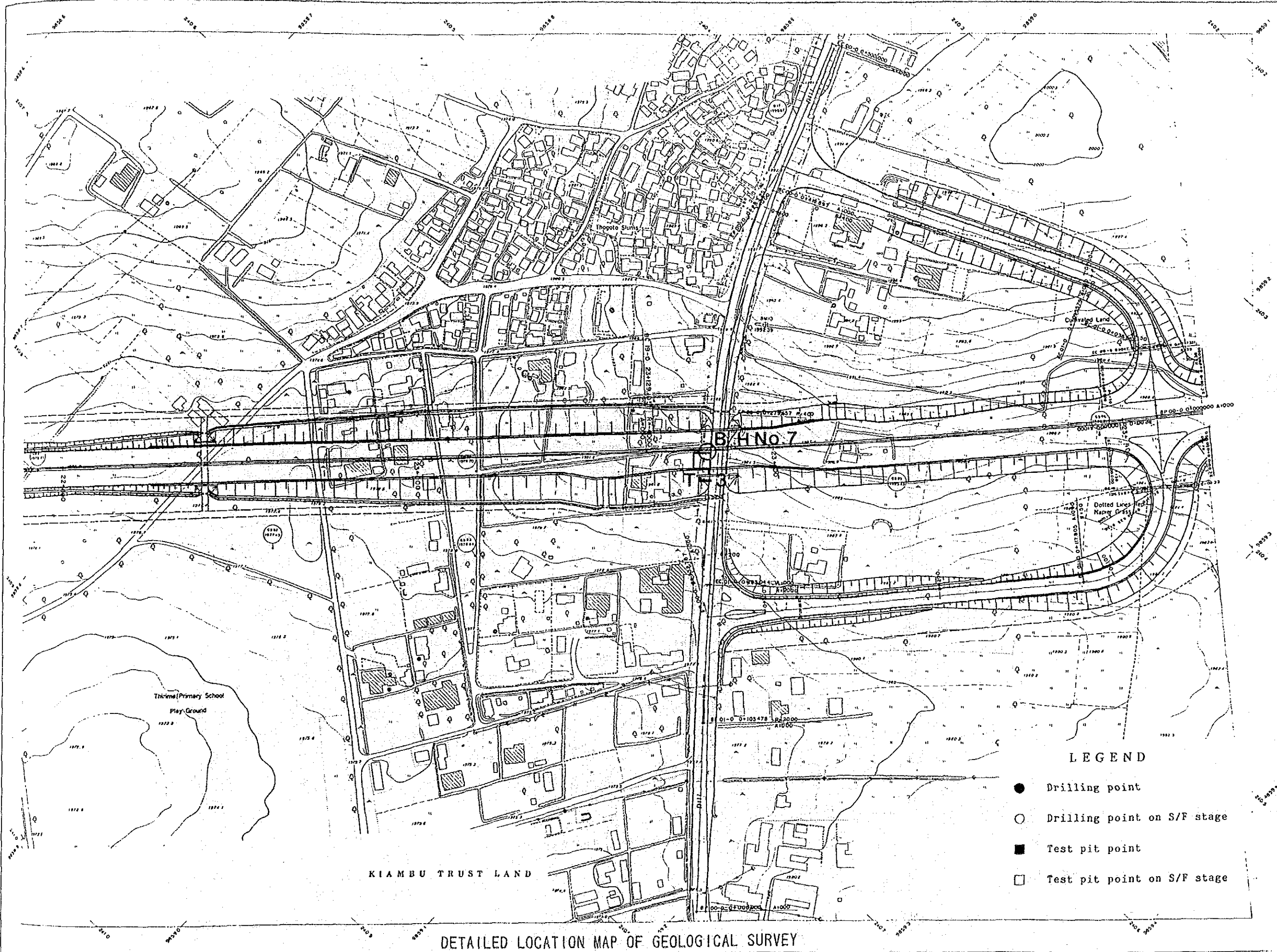

Scale 1:2,000
HEIGHTS IN METERS

- LEGEND**
- △ GPS Point
 - Traverse Point
 - ⊙ Bench Mark
 - 1234.5 Direct Leveling Height
 - 1234.5 Spot Height
 - 1234.5 Contours (V.L. Int)
 - Outcrop (Rock)
 - Building, Permanent
 - Building, Others
 - Bituminous Road
 - Road
 - Track
 - Railway
 - Bridge, Culvert
 - River
 - Stream
 - Dam
 - Pool
 - Water Tank
 - Power Line
 - Telephone Line
 - Fence, Gate
 - Hedge
 - Stone Wall
 - Dump or Mound
 - Quarry, Pit
 - Cutting
 - Embankment
 - Cultivated Lands
 - Orchard or Permanent C
 - Plantation
 - Grassland
 - Bush
 - Forest
 - Swamp
 - Vegetation Boundary
 - Planning Partition

HORIZONTAL DATUM UTM ZONE 37
CLARKE 1866 SPHER

VERTICAL DATUM MEAN SEA LEVEL

AERIAL PHOTOGRAPHED BY JICA
Japan International Cooperation Agency
December

GROUND CONTROL SURVEYED BY JICA
December

STEREO PLOTTED BY JICA
MARCH

CARTOGRAPHED BY JICA
MAY

CHEF ENGINEER _____
DATE _____

CHEF SUPT. ENG. _____
DATE _____

CHECKED BY _____
DATE _____

PROJECT ENGINEER _____
DATE _____

MINISTRY OF PUBLIC WORKS

M.O.P.W.

OFFICE OF ORIGIN
JICA TOKYO, JAPAN

SHEET 37 OF 46

- LEGEND**
- Drilling point
 - Drilling point on S/F stage
 - Test pit point
 - Test pit point on S/F stage

DETAILED LOCATION MAP OF GEOLOGICAL SURVEY

THE DETAILED DESIGN STUDY ON THE NAIROBI BYPASS PROJECT

SHEET NO. 38

37 38 39
37-2
INDEX TO ADJOINING SHEET

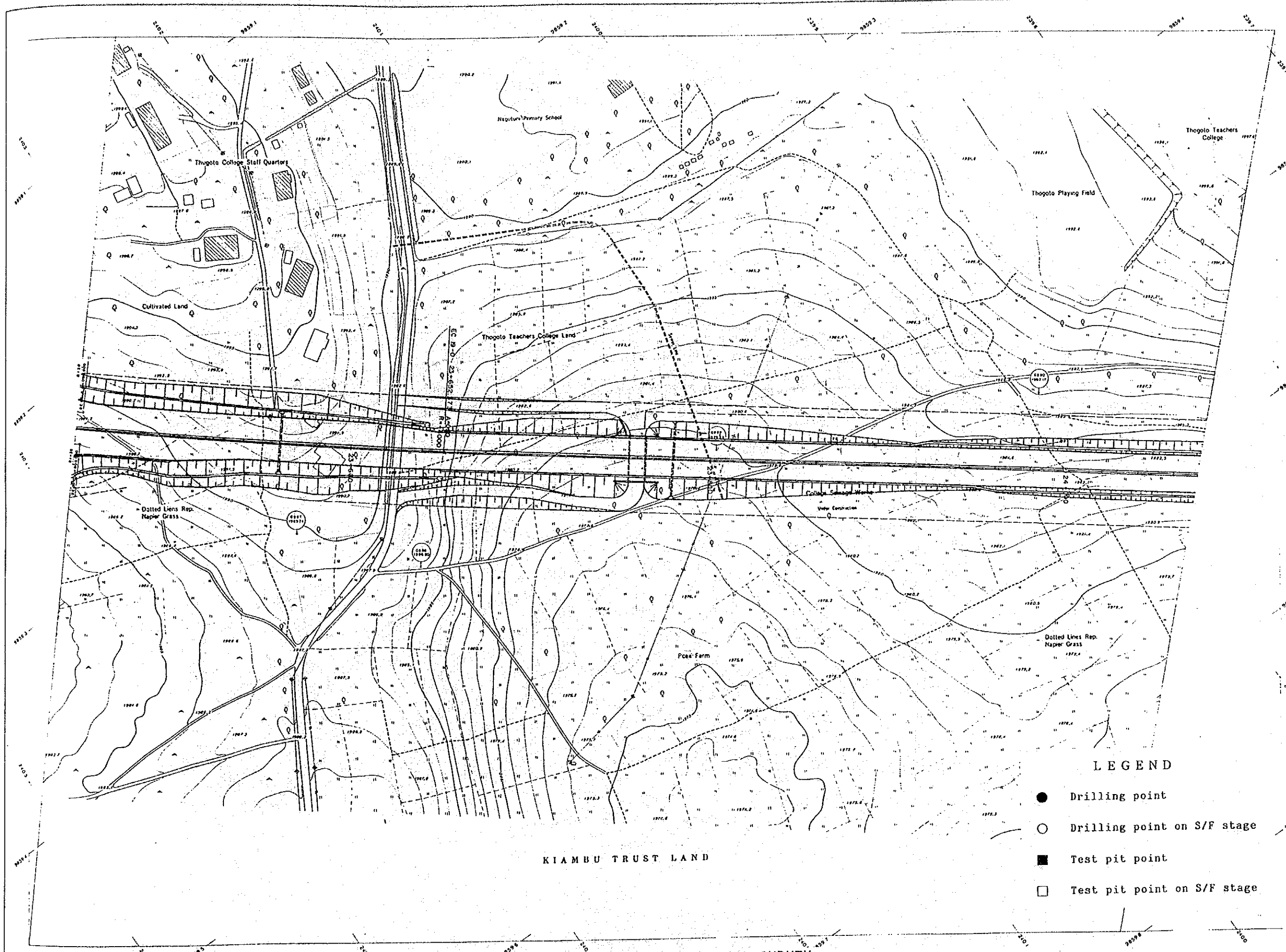

Scale 1:12,000
HEIGHTS IN METERS

- LEGEND**
- △ GTS Point
 - Traverse Point
 - ⊕ Bench Mark
 - 1224.5 Direct Leveling Ht.
 - 1222.3 Spot Height
 - 1225.1 Contours 1:1 km
 - ▨ Obcrop (Rock)
 - ▩ Building (Permanent)
 - ▩ Building (Others)
 - ▩ Bituminous Road
 - ▩ Road
 - ▩ Track
 - ▩ Railway
 - ▩ Bridge, Culvert
 - ▩ River
 - ▩ Stream
 - ▩ Dam
 - ▩ Dyke
 - Water Tank
 - ⊕ Power Line
 - ⊕ Telephone Line
 - ▩ Fence, Gate
 - ▩ Hedge
 - ▩ Stone Wall
 - ▩ Dump or Mound
 - ▩ Quarry, Pit
 - ▩ Cutting
 - ▩ Embankment
 - ▩ Cultivated Lands
 - ▩ Orchard or Permanent
 - ▩ Plantation
 - ▩ Grassland
 - Bush
 - Forest
 - ▩ Swamp
 - ▩ Vegetation Boundary
 - ▩ Planning Partition

HORIZONTAL DATUM: UTM ZONE
KILMER 1948 SPI

VERTICAL DATUM: MEAN SEA LEVEL

AERIAL PHOTOGRAPHY BY:
Japan International Co-operative
Economic

GROUND CONTROL SURVEYED BY:
Dover

STEREO PLOTTED BY:
MAI

CARTOGRAPHY BY:
F

- LEGEND**
- Drilling point
 - Drilling point on S/F stage
 - Test pit point
 - Test pit point on S/F stage

CHECKED BY:

CHIEF ENGINEER
DATE: / /

CHIEF SUPT. ENG.
DATE: / /

SEN. SUPT. ENG.
DATE: / /

SUPT. ENGINEER
DATE: / /

PROJECT ENGINEER
DATE: / /

MINISTRY OF PUBLIC WORKS

M.O.P.W

OFFICE OF ORIGIN
JICA TOKYO, JAP

CHECKED BY: / /

DETAILED LOCATION MAP OF GEOLOGICAL SURVEY

THE DETAILED DESIGN STUDY ON THE NAIROBI BYPASS PROJECT

SHEET NO. 39

38 39 40

INDEX TO ADJOINING SHEET

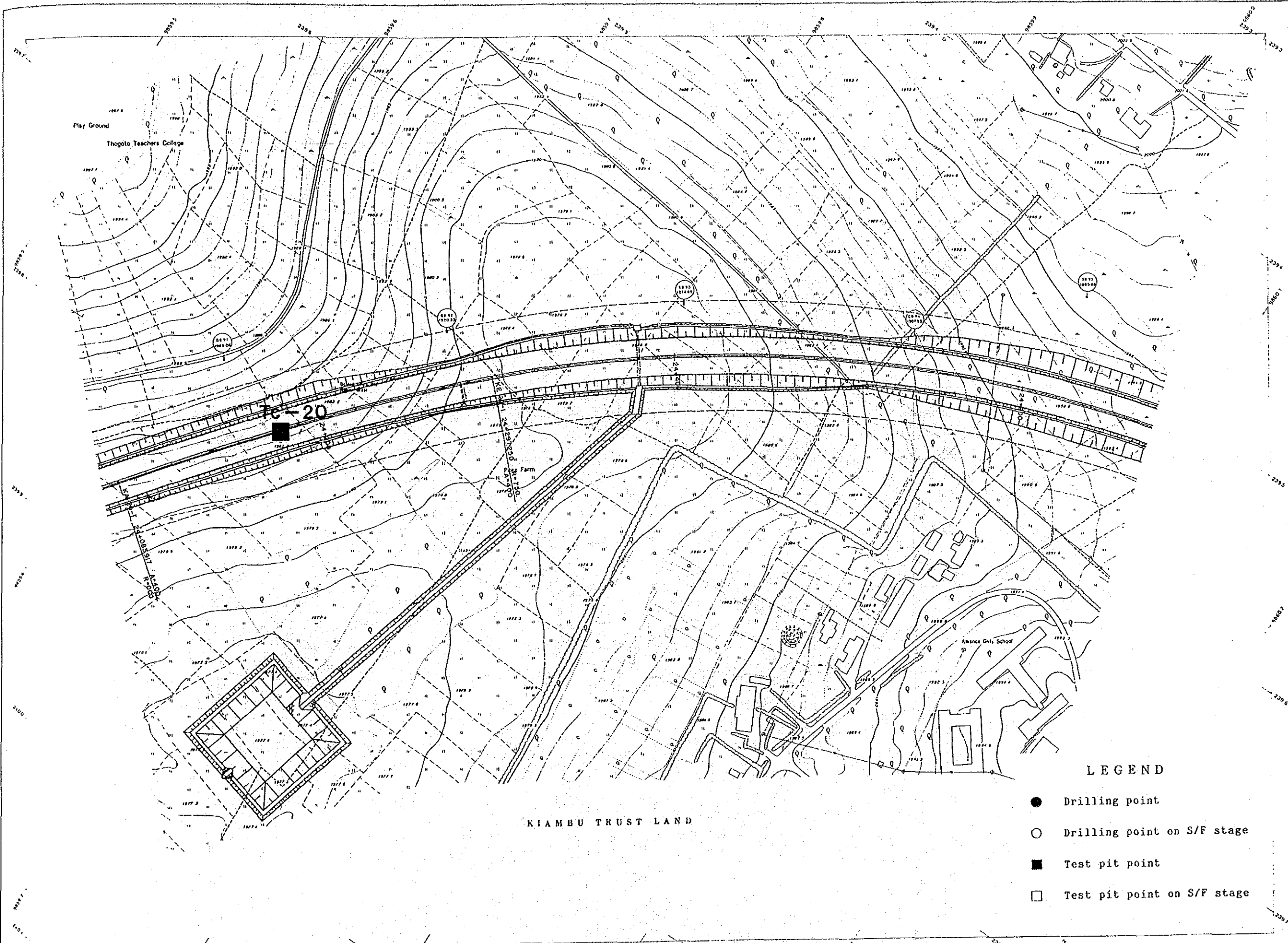

Scale 1:12,000
HEIGHTS IN METERS

- LEGEND**
- ⊙ GPS Point
 - ⊕ Traverse Point
 - ⊕ Bench Mark
 - 1234.5 Direct Leveling Heu
 - 1234.5 Spot Height
 - Contours (1:1 Int)
 - ⊠ Outcrop (Rock)
 - ▨ Building, Permanent
 - ▨ Building, Others
 - ▨ Bituminous Road
 - ▨ Road
 - ▨ Track
 - ▨ Railway
 - ▨ Bridge, Culvert
 - ▨ River
 - ▨ Stream
 - ⊕ Dam
 - ⊕ Pond
 - ⊕ Water Tank
 - ⊕ Power Line
 - ⊕ Telephone Line
 - ▨ Fence, Gate
 - ▨ Hedge
 - ▨ Stone Wall
 - ⊕ Dump or Mound
 - ⊕ Quarry, Pit
 - ▨ Cutting
 - ▨ Embankment
 - ▨ Cultivated Lands
 - ▨ Orchard or Permanent
 - ▨ Plantation
 - ▨ Grassland
 - ⊕ Bush
 - ⊕ Forest
 - ▨ Swamp
 - ▨ Vegetation Boundary
 - ▨ Planning Partition

HORIZONTAL DATUM UTM ZONE 1
CLARKE 1866 SPH

VERTICAL DATUM MEAN SEA LEVEL

AERIAL PHOTOGRAPHY BY
Japan International Cooperation Agency

GROUND CONTROL SURVEYED BY
Levent

STEREO PLOTTED BY
MARK

CARTOGRAPHY BY
JI

CHIEF ENGINEER
DATE:

CHIEF SUPT. ENG.
DATE:

CHIEF SUPT. ENG.
DATE:

SUPT. ENGINEER
DATE:

PROJECT ENGINEER
DATE:

MINISTRY OF PUBLIC WORKS

M.O.P.W.

OFFICE OF ORIGIN
JICA TOKYO, JAPAN

- LEGEND**
- Drilling point
 - Drilling point on S/F stage
 - Test pit point
 - Test pit point on S/F stage

DETAILED LOCATION MAP OF GEOLOGICAL SURVEY

THE DETAILED DESIGN STUDY ON THE NAIROBI BYPASS PROJECT

SHEET NO. 40

40

INDEX TO ADJOINING SHEETS

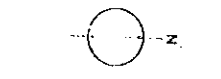
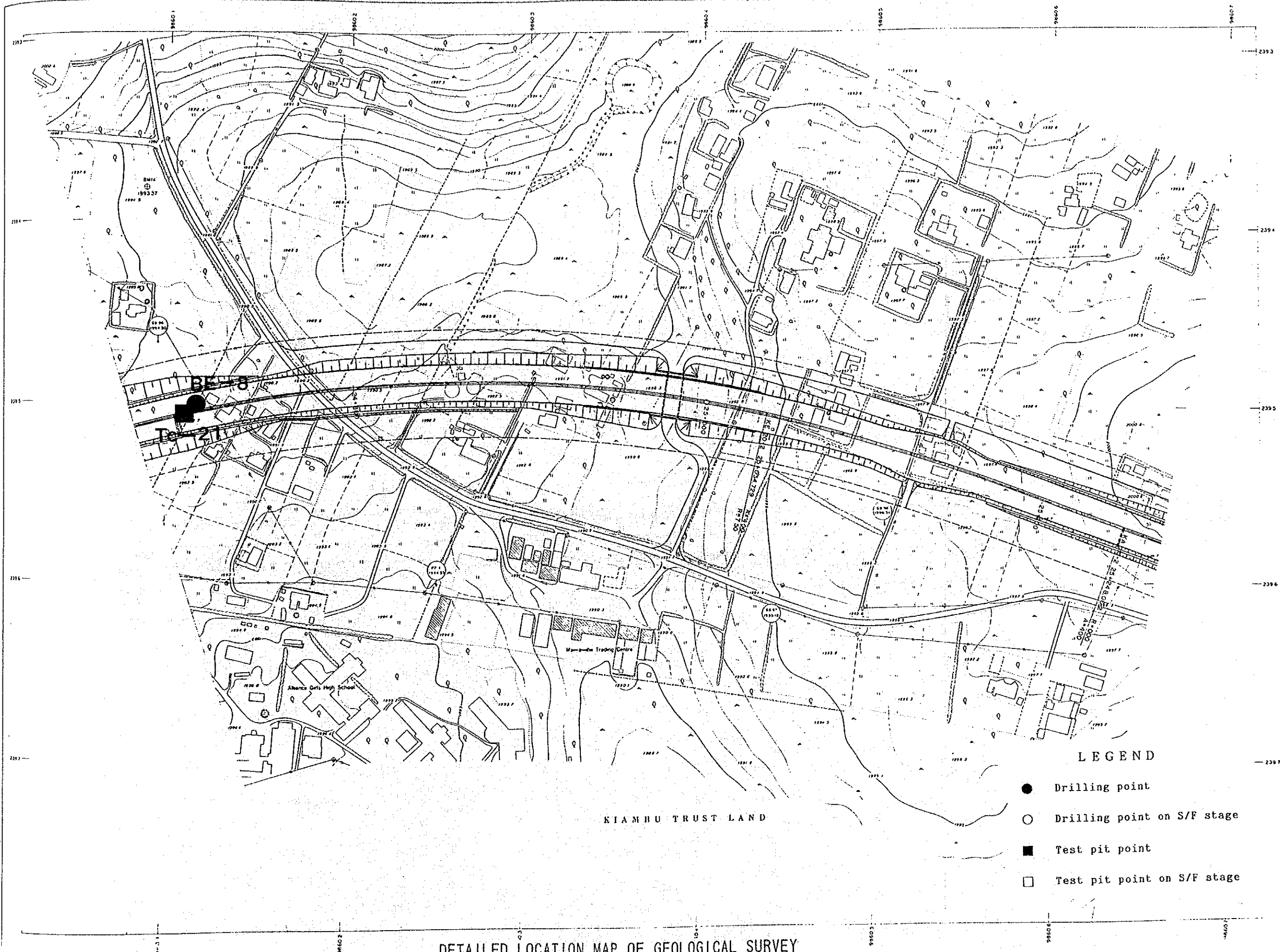

Scale 1:2,000
HEIGHTS IN METERS

LEGEND

	GPS Point
	Traverse Point
	Bench Mark
	Direct Leveling Height
	Spot Height
	Contours (V.L. Int)
	Outcrop Blocks
	Building (Permanent)
	Building (Others)
	Paved Road
	Road
	Track
	Railway
	Bridge, Culvert
	River
	Stream
	Dam
	Pond
	Water Tank
	Power Line
	Telephone Line
	Fence, Gate
	Hedge
	Stone Wall
	Dump or Mound
	Quarry, Pit
	Cutting
	Embankment
	Cultivated Lands
	Orchard or Permanent
	Plantation
	Grassland
	Bush
	Forest
	Swamp
	Vegetation Boundary
	Planting Partition

HORIZONTAL DATUM UTM ZONE 36
CLARKE 1866 SPIE

VERTICAL DATUM MEAN SEA LEV

AERIAL PHOTOGRAPHED BY
Japan International Cooperation Agency
December

GROUND CONTROL SURVEYED BY
December

STEREO PLOTTED BY
MARC

CARTOGRAPHED BY
JUL

CHIEF ENGINEER
DATE

CHIEF SPT. ENG.
DATE

CHECKED BY
SEN. SPT. ENG.
DATE

DATE

PROJECT ENGINEER
DATE

MINISTRY OF PUBLIC WORKS

M.O.P.W.

OFFICE OF ORIGIN
JICA TOKYO, JAPAN

SHEET 40 OF 16

LEGEND

	Drilling point
	Drilling point on S/F stage
	Test pit point
	Test pit point on S/F stage

KIAMBU TRUST LAND

DETAILED LOCATION MAP OF GEOLOGICAL SURVEY

THE DETAILED DESIGN STUDY ON THE NAIROBI BYPASS PROJECT

SHEET NO. 41

40 41 42

INDEX TO ADJOINING SHEETS

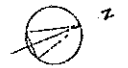
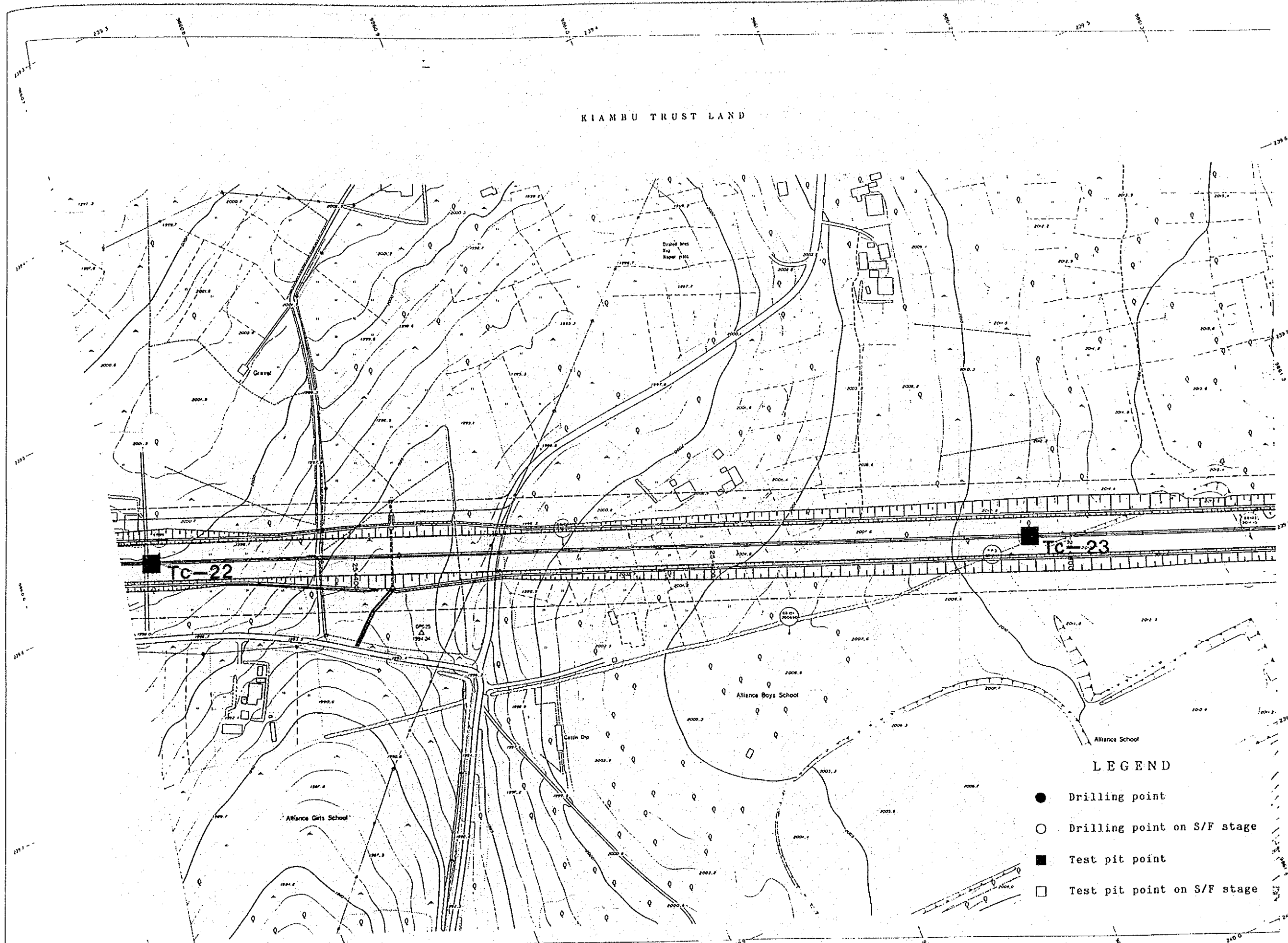

Scale 1:2,000
HEIGHTS IN METERS

LEGEND

- △ GIS Point
- Traverse Point
- ⊕ Bench Mark
- 1234.5 Direct Leveling Height
- 1234.5 Spot Height
- Contours (V.L. In)
- Outcrop (Rock)
- Building, Permanent
- Building, Others
- Illuminated Road
- Road
- Track
- Railway
- Bridge, Culvert
- River
- Stream
- Dam
- Flood
- Water Tank
- Power Line
- Telephone Line
- Fence, Gate
- Hedge
- Stone Wall
- Dump or Mound
- Quarry, Pit
- Cutting
- Embankment
- Cultivated Lands
- Orchard or Permanent C
- Plantation
- Grassland
- Bush
- Forest
- Swamp
- Vegetation Boundary
- Planting Partition

HORIZONTAL DATUM: UTM ZONE 37
CLARKE 1866 SPHER
VERTICAL DATUM: MEAN SEA LEVEL
AERIAL PHOTOGRAPHY BY: JICA
Japan International Cooperation Agency
December
GROUND CONTROL SURVEYED BY: JICA
December
STEREO PLOTTED BY: JICA
MARCH
CARTOGRAPHED BY: JICA
JULY

LEGEND

- Drilling point
- Drilling point on S/F stage
- Test pit point
- Test pit point on S/F stage

DETAILED LOCATION MAP OF GEOLOGICAL SURVEY

MINISTRY OF PUBLIC WORKS
M.O.P.W.
OFFICE OF ORIGIN
JICA TOKYO, JAPAN
SHEET 41 OF 46

THE DETAILED DESIGN STUDY ON THE NAIROBI BYPASS PROJECT

SHEET NO. 42

41 42 43

INDEX TO ADJOINING SHEETS

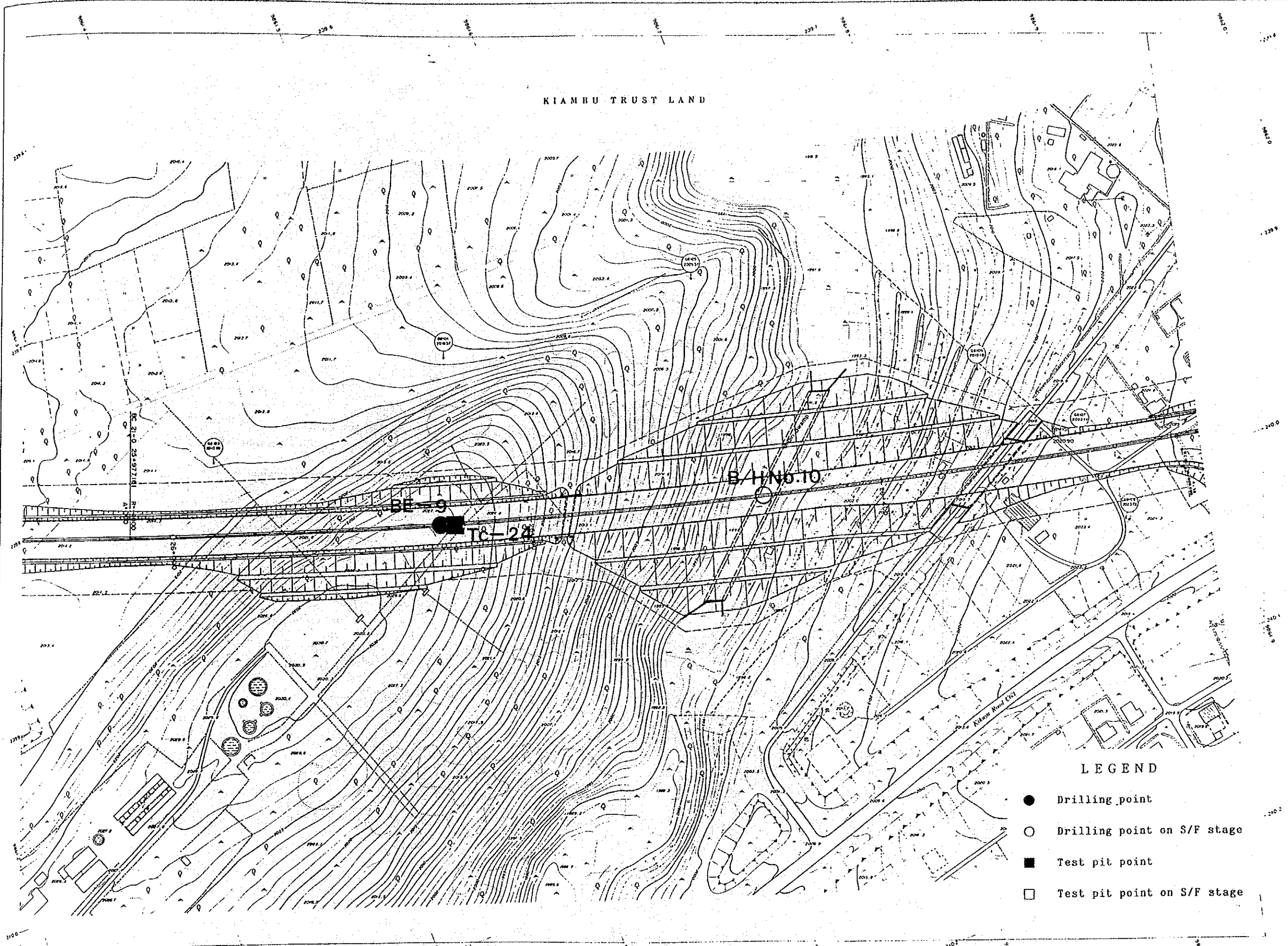

DETAILED LOCATION MAP OF GEOLOGICAL SURVEY

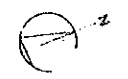

Scale 1:2,000
HEIGHTS IN METERS

LEGEND

- △ GPS Point
- ⊙ Traverse Point
- ⊕ Bench Mark
- 1234.5 Three Leveling High
- 123.4 Spot Height
- Contours (V.L. Int)
- Outcrop (Rocks)
- ▭ Building Permanent
- ▭ Building Others
- ▭ Bituminous Road
- ▭ Road
- ▭ Track
- ▭ Railway
- ▭ Ridge, Culvert
- ▭ River
- ▭ Stream
- ▭ Dam
- ▭ Fored
- ▭ Water Tank
- ▭ Power Line
- ▭ Telephone Line
- ▭ Fence, Gate
- ▭ Hedger
- ▭ Stone Wall
- ▭ Dump or Mound
- ▭ Quarry Pit
- ▭ Cutting
- ▭ Embankment
- ▭ Cultivated Land
- ▭ Orchard or Permanent
- ▭ Plantation
- ▭ Grassland
- ▭ Bush
- ▭ Forest
- ▭ Swamp
- ▭ Vegetation Boundary
- ▭ Planting Partition

HORIZONTAL DATUM: UTM ZONE 35
CLARKE 1866 SPHEROID

VERTICAL DATUM: MEAN SEA LEVEL

AERIAL PHOTOGRAPHY BY:
Japan International Corporation
Recent

GROUND CONTROL SURVEYED BY:
Recent

STAKED PLOTTED BY: MARK

CARTOGRAPHY BY: JUI

LEGEND

- Drilling point
- Drilling point on S/F stage
- Test pit point
- Test pit point on S/F stage

CHIEF ENGINEER
DATE

CHIEF SUFF. ENG.
DATE

CHECKED BY:
SEN. SUFF. ENG.
DATE

SUFF. ENGINEER
DATE

PROJECT ENGINEER
DATE

MINISTRY OF PUBLIC WORKS

M.O.P.W.

OFFICE OF ORIGIN
JICA TOKYO JAP.

SHEET 42 OF 46

THE DETAILED DESIGN STUDY ON THE NAIROBI BYPASS PROJECT

SHEET NO. 43

42 43 44

INDEX TO ADJOINING SHEETS

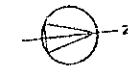
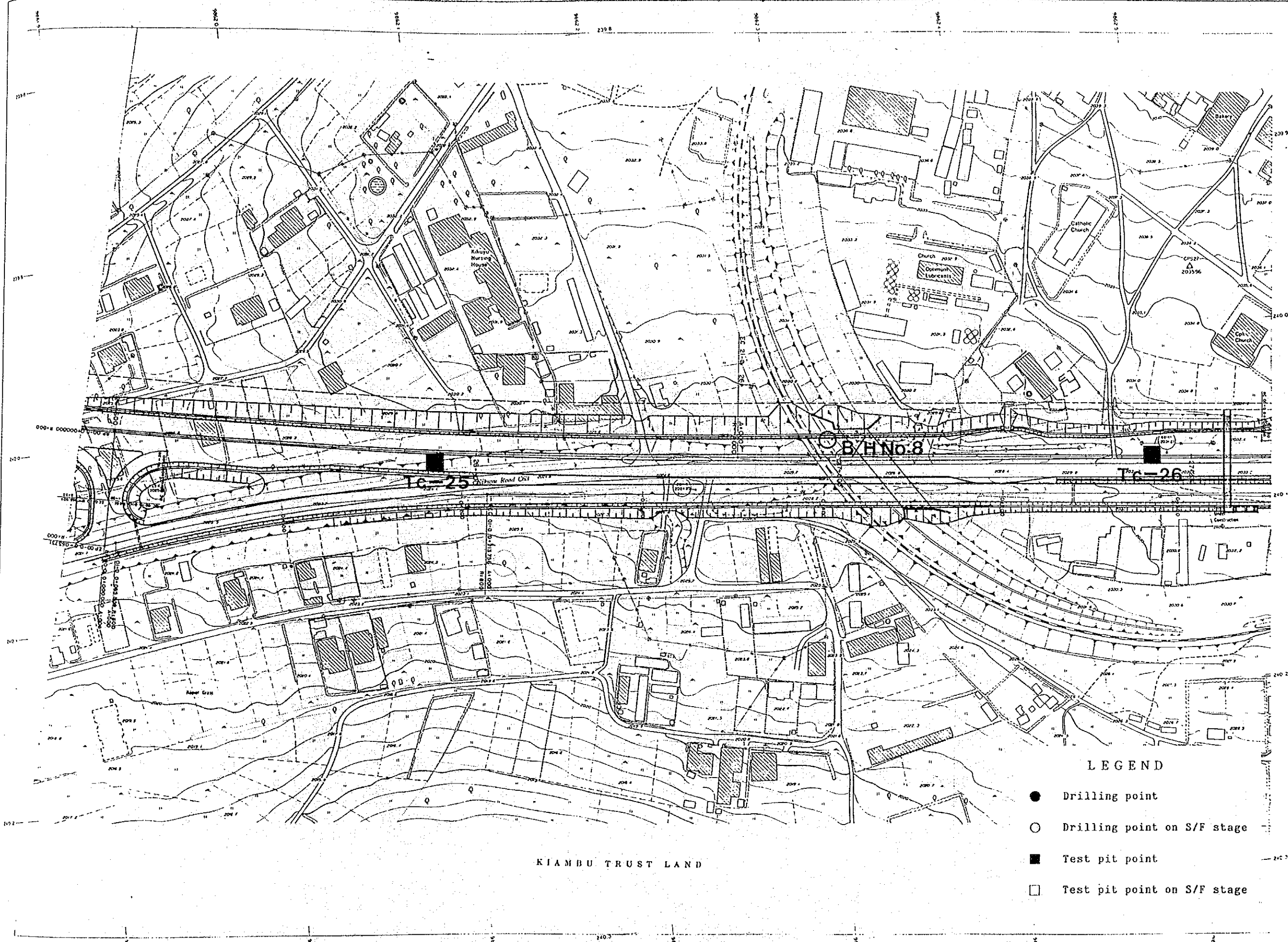

Scale 1:2,000
HEIGHTS IN METERS

- LEGEND**
- △ GIS Point
 - ⊙ Traverse Point
 - ⊕ Bench Mark
 - 1234.5 Direct Leveling Height
 - 1234.5 Spot Height
 - 1234.5 Contours (V.I. Line)
 - ⊠ Outcrop (Rock)
 - ▨ Building, Permanent
 - ▨ Building, Others
 - ▨ Discontinued Road
 - ▨ Road
 - ▨ Track
 - ▨ Railway
 - ▨ Hoop, Culvert
 - ▨ River
 - ▨ Stream
 - ▨ Dam
 - ▨ Pond
 - ▨ Water Tank
 - ▨ Power Line
 - ▨ Telephone Line
 - ▨ Fence, Gate
 - ▨ Hedge
 - ▨ Stone Wall
 - ▨ Dump or Mound
 - ▨ Quarry, Pit
 - ▨ Cutting
 - ▨ Embankment
 - ▨ Cultivated Lands
 - ▨ Orchard or Permanent C
 - ▨ Plantation
 - ▨ Grassland
 - ▨ Bush
 - ▨ Forest
 - ▨ Swamp
 - ▨ Vegetation Boundary
 - ▨ Planning Partition

HORIZONTAL DATUM: UTM ZONE 37
CLARKE 1866 SPIEGEL

VERTICAL DATUM: MEAN SEA LEVEL

AERIAL PHOTOGRAPHY BY
Japan International Cooperation Agency
December

GROUND CONTROL SURVEYED BY
December

STEREO PLOTTED BY
MARU

CARTOGRAPHY BY
J.U.

CHIEF ENGINEER
DATE

CHIEF S/PT. ENG.
DATE

CHECKED BY: SEN. S/PT. ENG.
DATE

CHIEF ENGINEER
DATE

PROJECT ENGINEER
DATE

MINISTRY OF PUBLIC WORKS

M.O.P.W.

OFFICE OF ORIGIN
JICA TOKYO, JAPAN

SHEET 43 OF 48

- LEGEND**
- Drilling point
 - Drilling point on S/F stage
 - Test pit point
 - Test pit point on S/F stage

KIAMBU TRUST LAND

DETAILED LOCATION MAP OF GEOLOGICAL SURVEY

THE DETAILED DESIGN STUDY ON THE NAIROBI BYPASS PROJECT

SHEET NO. 44

43 44 45

INDEX TO ADJOINING SHEETS

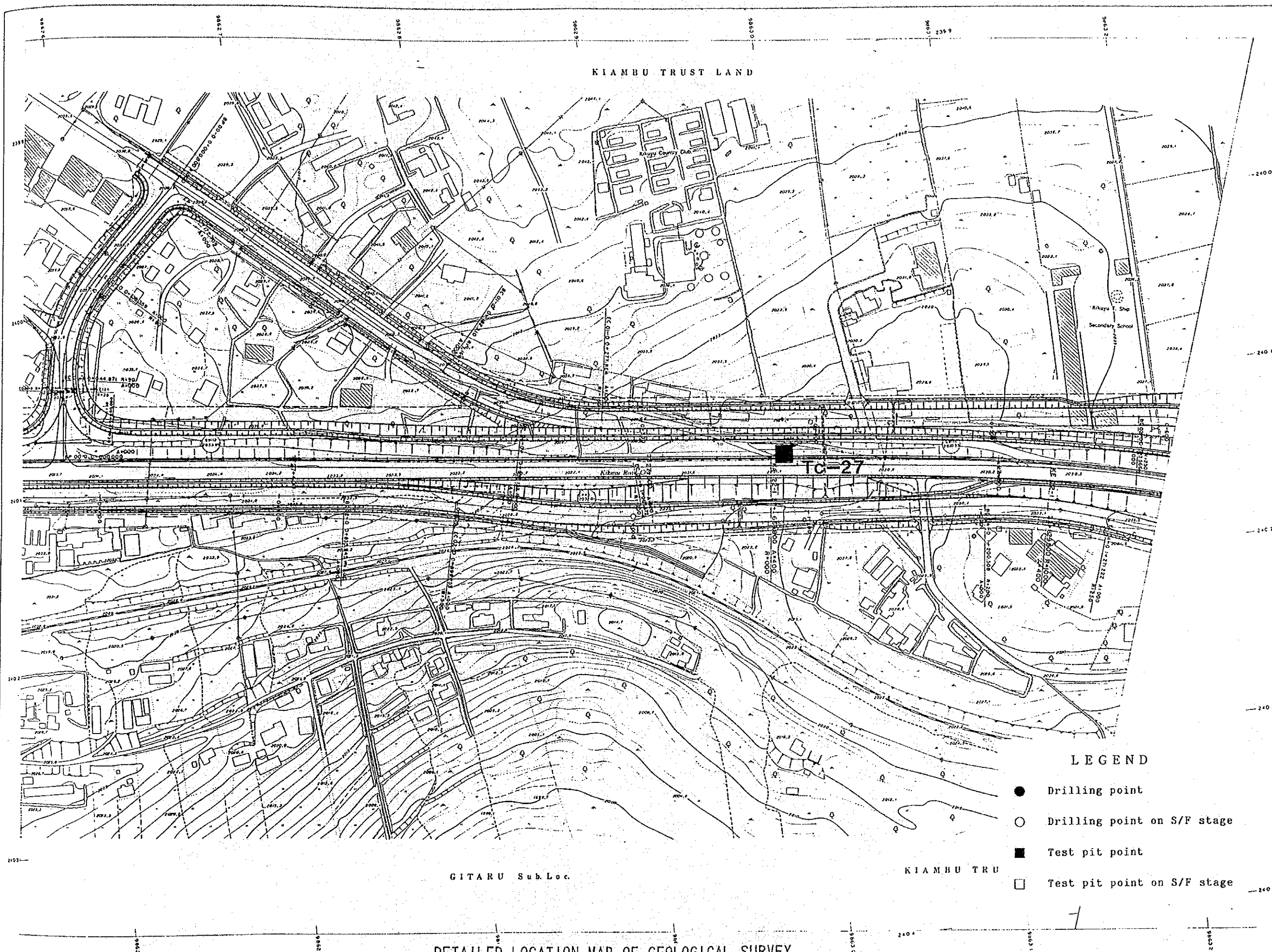

Scale 1 : 2,000
HEIGHTS IN METERS

LEGEND

- △ GNS Point
- Travese Point
- Bench Mark
- 1234.5 Direct Leveling Height
- 1234.5 Spot Height
- Contours (V.I. Int.)
- Outcrop (Rocks)
- Building Farmhouse
- Building Others
- Bituminous Road
- Road
- Track
- Railway
- Hindoe Culvert
- River
- Stream
- Dam
- Pond
- Water Tank
- Power Line
- Telephone Line
- Fence, Gate
- Hedger
- Stone Wall
- Dump or Mound
- Quarry Pit
- Cutting
- Embankment
- Cultivated Lands
- Orchard or Permanent C.
- Plantation
- Grassland
- Bush
- Forest
- Swamp
- Vegetation Boundary
- Planting Partition

HORIZONTAL DATUM UTM ZONE 37
CLARKE 1866 SPIRE

VERTICAL DATUM MEAN SEA LEVEL

AERIAL PHOTOGRAPHED BY JI
Japan International Co-operation Agency
December

GROUND CONTROL SURVEYED BY JI
December

STEREO PLOTTED BY JI
MARCH

CARTOGRAPHED BY JI
JULY

CHEF ENGINEER DES. DATE / /

CHEF SFT. ENG. DES. DATE / /

CHEKED BY: SEN. SFT. ENG. DES. DATE / /

SFT. ENGINEER DES. DATE / /

PROJECT ENGINEER DATE / /

MINISTRY OF PUBLIC WORKS

M.O.P.W.

OFFICE OF ORIGIN
JICA TOKYO, JAPAN

SHEET 44 OF 46

- ### LEGEND
- Drilling point
 - Drilling point on S/F stage
 - Test pit point
 - Test pit point on S/F stage

DETAILED LOCATION MAP OF GEOLOGICAL SURVEY

THE DETAILED DESIGN STUDY ON THE NAIROBI BYPASS PROJECT

SHEET NO. 45

44 45 46

INDEX TO ADJOINING SHEETS

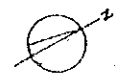
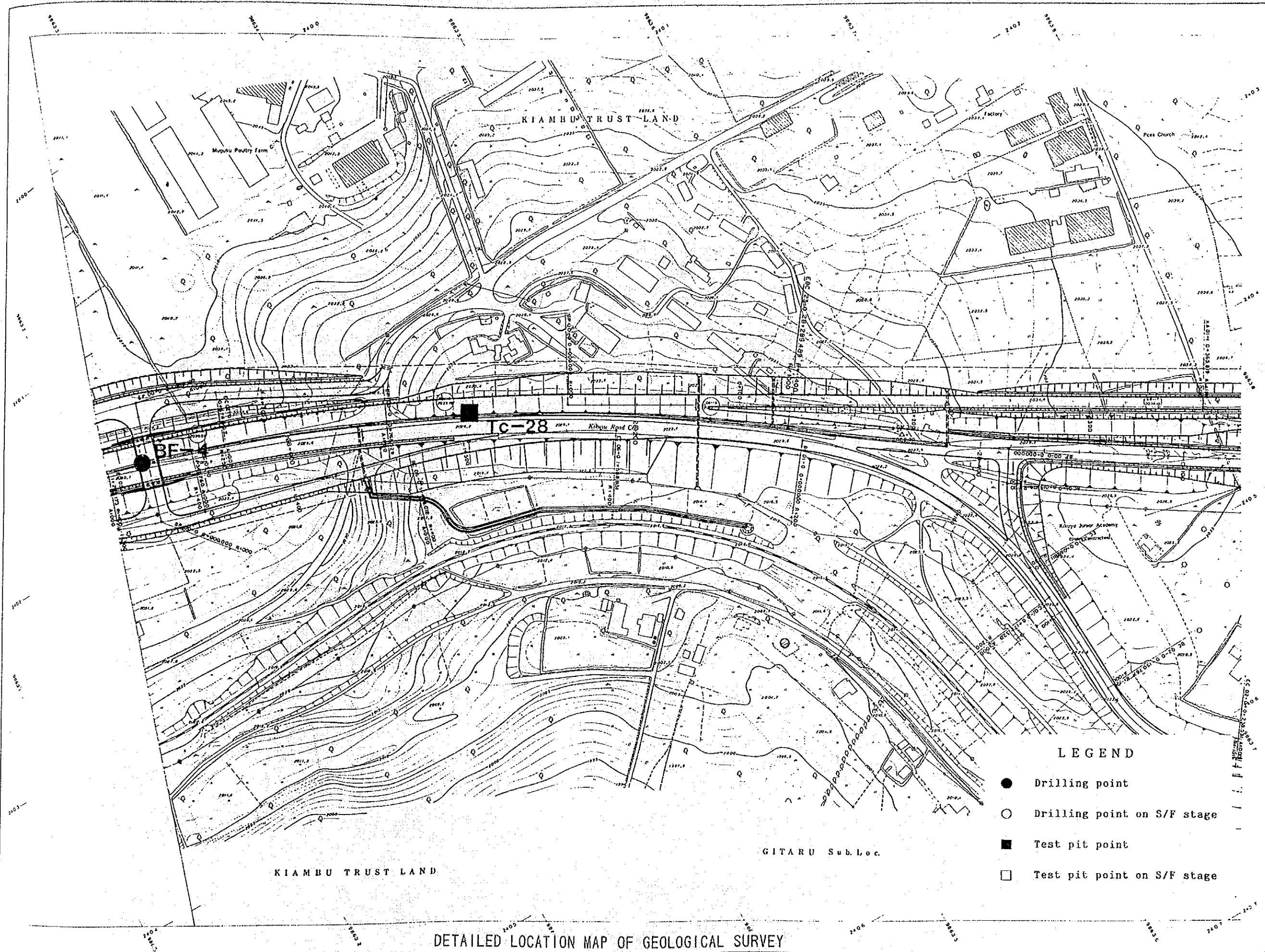

Scale 1 : 2,000
HEIGHTS IN METERS

LEGEND

- △ GPS Point
- Traversed Point
- ⊕ Bench Mark
- 1234.5 Direct Leveling Height
- 234.5 Spot Height
- 232.5 Contour (V.L. line)
- ⊞ Outcrop (Rock)
- ▨ Building, Permanent
- ▨ Building, Others
- ▨ Bituminous Road
- ▨ Road
- ▨ Track
- ▨ Railway
- ▨ Bridge, Culvert
- ▨ River
- ▨ Stream
- ▨ Dam
- ▨ Well
- ▨ Water Tank
- ▨ Power Line
- ▨ Telephone Line
- ▨ Fence, Gate
- ▨ Hedge
- ▨ Stone Wall
- ▨ Damp or Mound
- ▨ Quarry Pit
- ▨ Cutting
- ▨ Embankment
- ▨ Cultivated Land
- ▨ Orchard or Permanent Cr.
- ▨ Plantation
- ▨ Grassland
- Bush
- Forest
- ▨ Swamp
- ▨ Vegetation Boundary
- ▨ Planting Partition

HORIZONTAL DATUM UTM ZONE 32
CLARKE 1866 SPHER.

VERTICAL DATUM MEAN SEA LEVEL

AERIAL PHOTOGRAPHY BY JR
Japan International Cooperation Agency
December

GROUND CONTROL SURVEYED BY JB
December

STEREO PLOTTED BY JR
MARCH

CARTOGRAPHY BY JR
JULY

LEGEND

- Drilling point
- Drilling point on S/F stage
- Test pit point
- Test pit point on S/F stage

CHIEF ENGINEER (S) DATE

CHIEF SUPT. ENG. (S) DATE

CHECKED BY SEN SUPT. ENG. (S) DATE

SUPT. ENGINEER (S) DATE

PROJECT ENGINEER DATA

MINISTRY OF PUBLIC WORKS

M.O.P.W.

OFFICE OF ORIGIN
JICA TOKYO, JAPAN

SHEET 45 OF 46

DETAILED LOCATION MAP OF GEOLOGICAL SURVEY

THE DETAILED DESIGN STUDY ON THE NAIROBI BYPASS PROJECT

SHEET NO. 46

45 46

INDEX TO ADJOINING SHEET

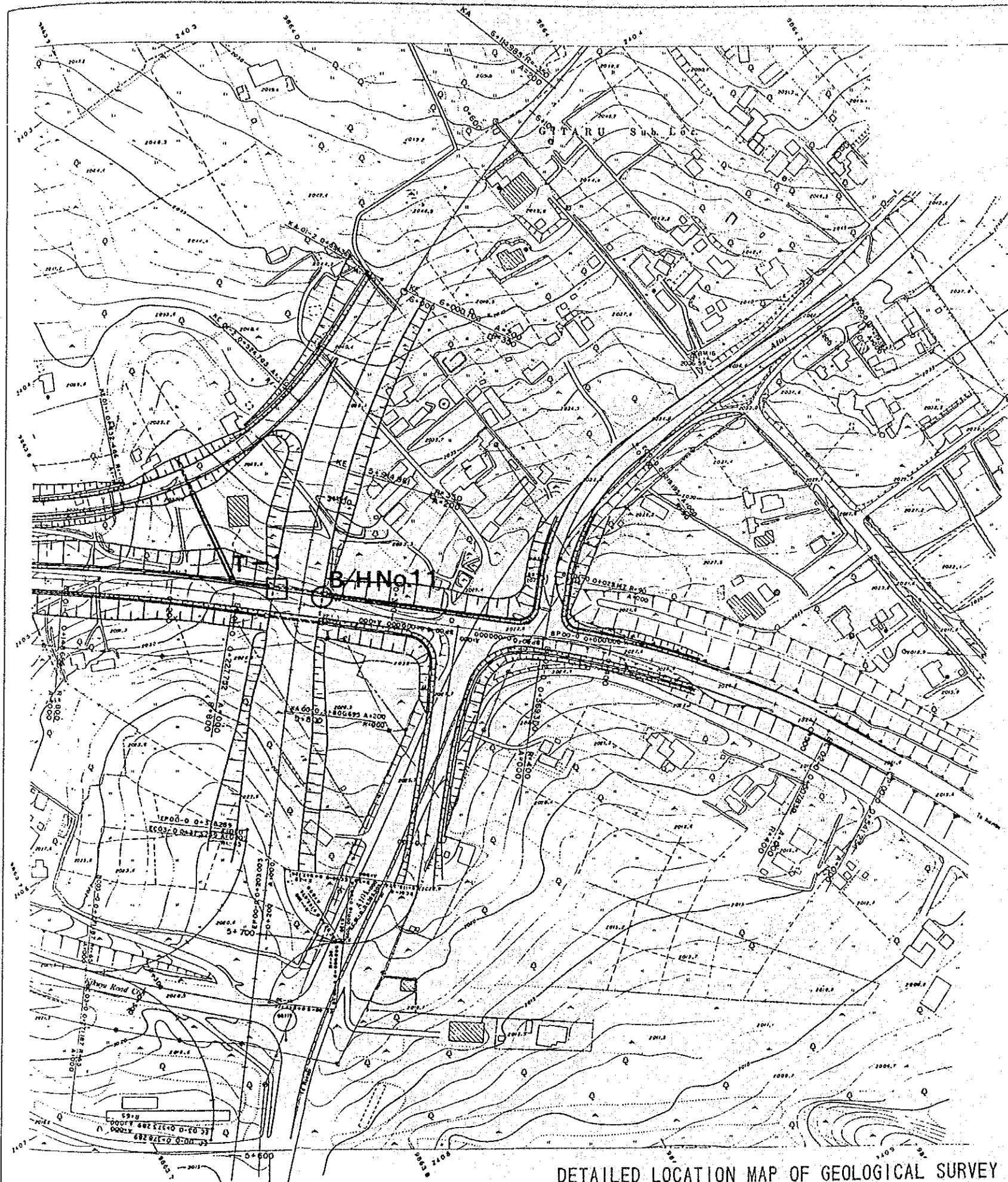

DETAILED LOCATION MAP OF GEOLOGICAL SURVEY

Scale 1: 2,000
HEIGHTS IN METERS

LEGEND

- △ GPS Point
- Traverse Point
- ⊕ Bench Mark
- 1234.5 Direct Leveling Height
- 1234.5 Spot Height
- Contours (1 m)
- Outcrop (Rock)
- ▭ Building (Permanent)
- ▭ Building (Other)
- ▭ Hampered Road
- ▭ Road
- ▭ Track
- ▭ Railway
- ▭ Bridge, Culvert
- ▭ River
- ▭ Stream
- ▭ Dam
- ▭ Pond
- ▭ Water Tank
- ▭ Power Line
- ▭ Telephone Line
- ▭ Fence, Gate
- ▭ Hedge
- ▭ Stone Wall
- ▭ Dump or Mound
- ▭ Quarry, Pit
- ▭ Cutting
- ▭ Embankment
- ▭ Cultivated Land
- ▭ Orchard or Permanent C.
- ▭ Plantation
- ▭ Grassland
- ▭ Bush
- ▭ Forest
- ▭ Swamp
- ▭ Vegetation Boundary
- ▭ Planting Partitions

HORIZONTAL DATUM: UTM ZONE 32
(CLARKE 1866 SPHER)

VERTICAL DATUM: MEAN SEA LEVEL

AERIAL PHOTOGRAPHY BY: JB
(Japan International Co-operation Ass.)
December

GROUND CONTROL SURVEYED BY: JB
December

STEREO PLOTTED BY: JB
MARCH

CARTOGRAPHED BY: JB
JULY

LEGEND

- Drilling point
- Drilling point on S/F stage
- Test pit point
- Test pit point on S/F stage

CHIEF ENGINEER: JB
DATE: / /

CHIEF SUPT. ENG.: JB
DATE: / /

CHECKED BY: SEN SUPT. ENG. JB
DATE: / /

SUPT. ENGINEER: JB
DATE: / /

PROJECT ENGINEER: JB
DATE: / /

MINISTRY OF PUBLIC WORKS

M.O.P.W.

OFFICE OF ORIGIN
JICA TOKYO, JAPAN

SHEET 46 OF 46

THE DETAILED DESIGN STUDY ON THE NAIROBI BYPASS PROJECT

SHEET NO. 46-1

140-1
45 46

INDEX TO ADJOINING SHEETS



Scale 1 : 2,000
HEIGHTS IN METERS

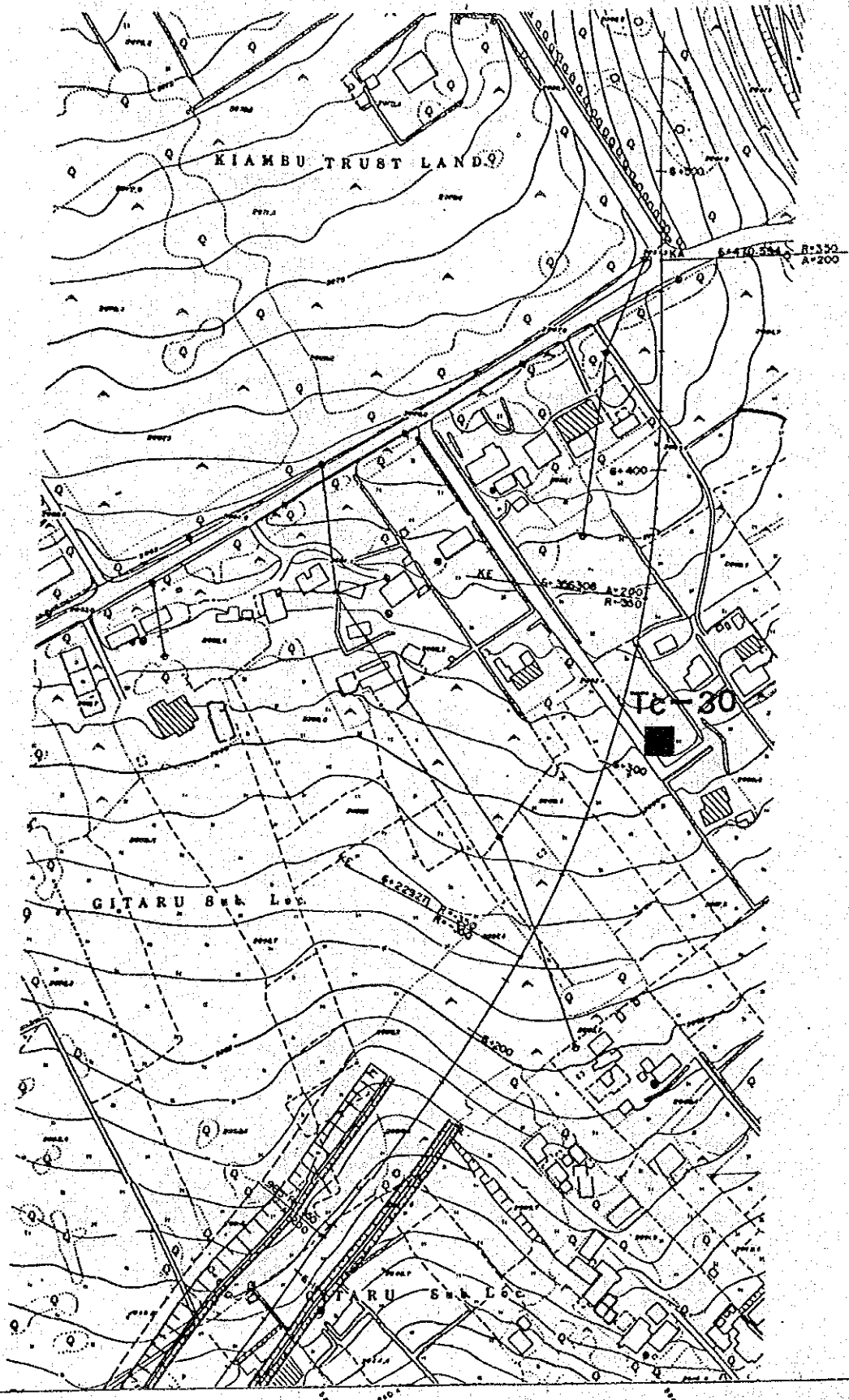

LEGEND

- GPS Point
- Traverse Point
- Bench Mark
- Three Leveling Height
- Spot Height
- Contour (1/10m)
- Outcrop (Rock)
- Building (Permanent)
- Building (Other)
- Unimproved Road
- Road
- Track
- Railway
- Bridge, Culvert
- River
- Stream
- Dam
- Pond
- Water Tank
- Power Line
- Telephone Line
- Fence, Gate
- Hedger
- Stone Wall
- Mound or Embankment
- Quarry Pit
- Cutting
- Embankment
- Cultivated Land
- Orchard or Permanent Crop
- Pasture
- Grassland
- Bush
- Forest
- Swamp
- Vegetation Boundary
- Fluvial Partition

HORIZONTAL DATUM: UTM ZONE 37
CLARK, 1960 SPHEROID

VERTICAL DATUM: MEAN SEA LEVEL

AERIAL PHOTOGRAPHY BY: JICA
Japan International Cooperation Agency
December 1991

GROUND CONTROL SURVEY BY: JICA
December 1991

STANDARD PLOTTED BY: JICA
MARCH 1992

CARTOGRAPHY BY: JICA
JULY 1992

LEGEND

- Drilling point
- Drilling point on S/F stage
- Test pit point
- Test pit point on S/F stage

CHECKED BY:	CHIEF ENGINEER	DATE	QUAD
	CHIEF SUPT. ENG.	DESIGN DATE	
	SEN. SUPT. ENG.	DESIGN DATE	
	SUPT. ENGINEER	DESIGN DATE	
	PROJECT ENGINEER	DATE	

MINISTRY OF PUBLIC WORKS

M.O.P.W.

OFFICE OF ORIGIN
JICA, TOKYO, JAPAN

SHEET 46-1 OF 46

DETAILED LOCATION MAP OF GEOLOGICAL SURVEY

2. GEOLOGICAL SECTION FOR FOUNDATION OF BRIDGES AND CUT SLOPES

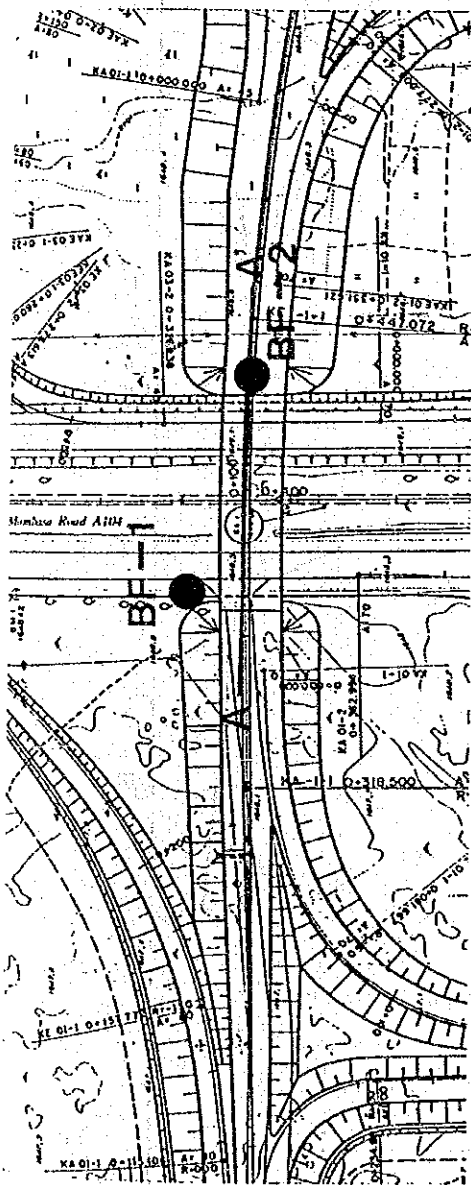

LEGEND

- Bank
- Black Cotton Soil
- Phonolitic Agglomerate

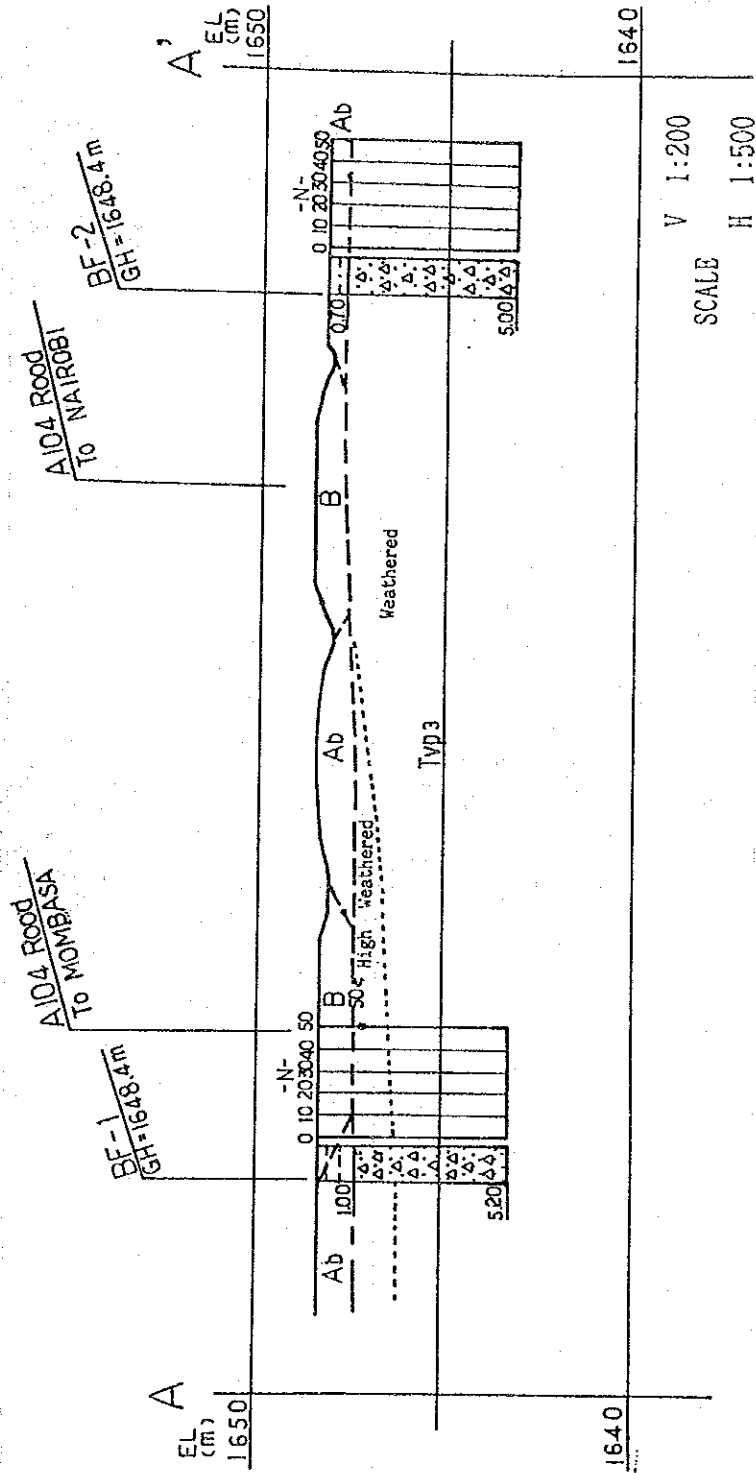
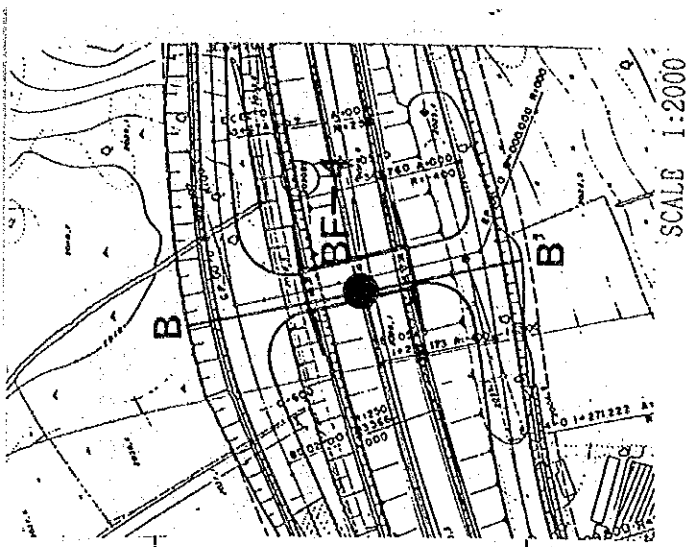

Fig. GEOLOGICAL SECTION (1)



LEGEND

- S Red Soil
- Plh High Weathered Trachyte

V 1:200
 H 1:500
 SCALE

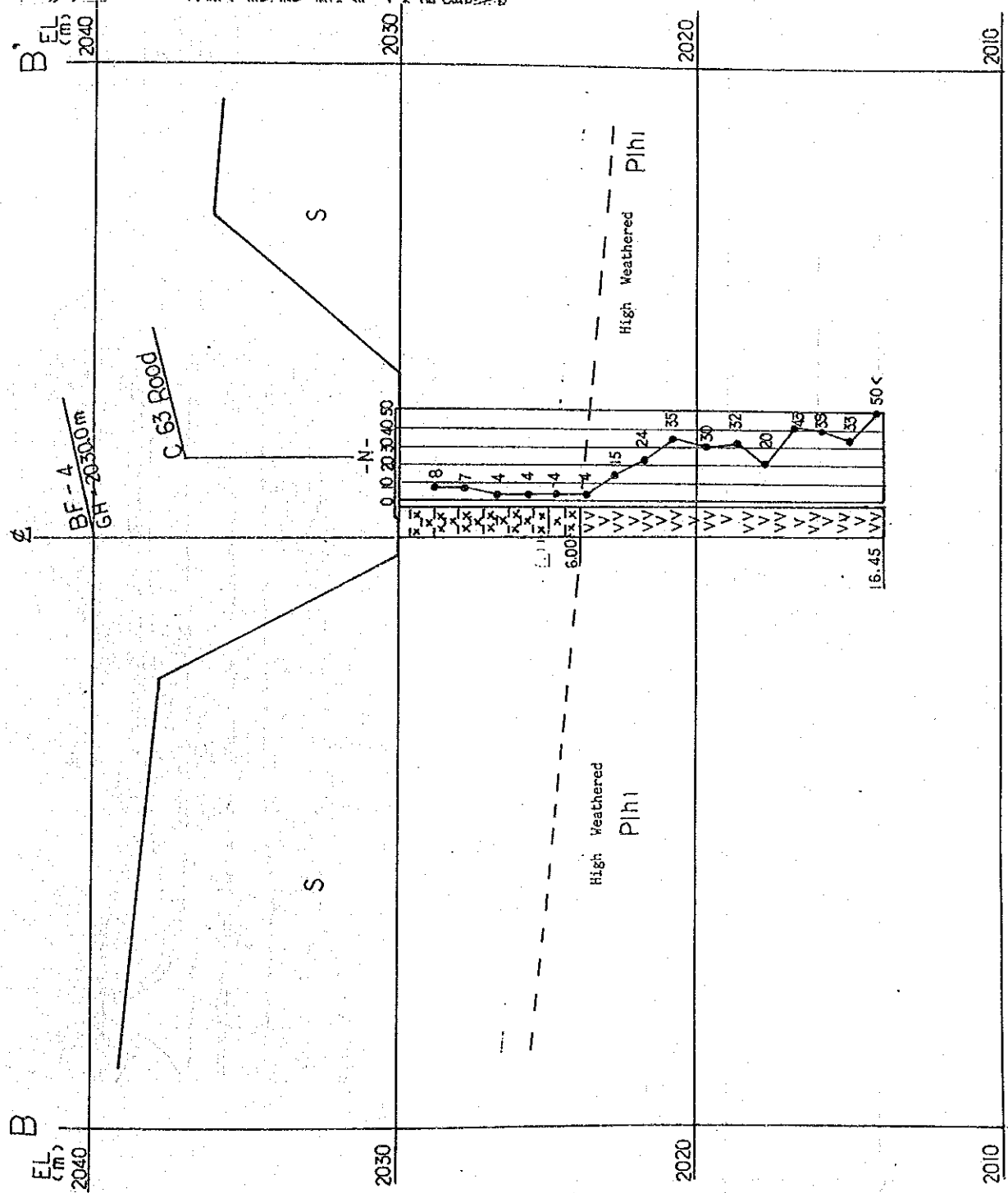
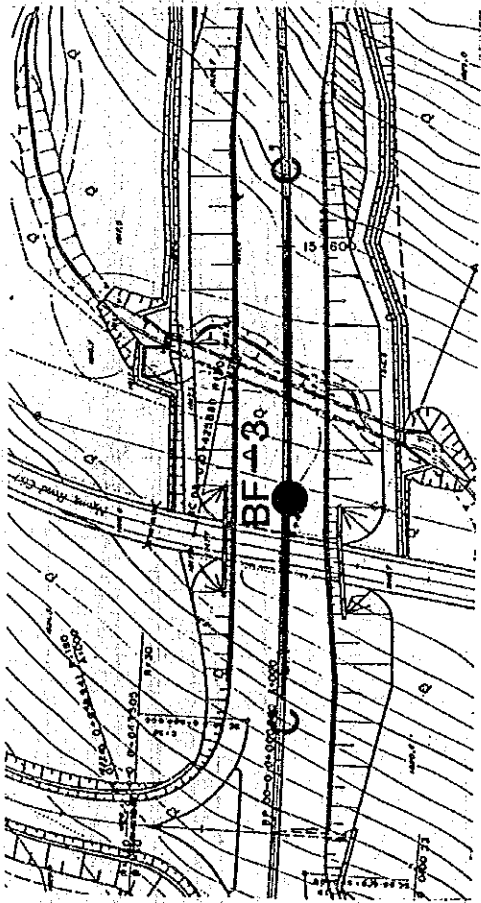

Fig. GEOLOGICAL SECTION (2)



LEGEND

- Ab Black Cotton Soil or Alluvium
- S Red Soil
- Tvtf2 Pyroclastic Tuff

SCALE V 1:200
H 1:500

SCALE 1:2000

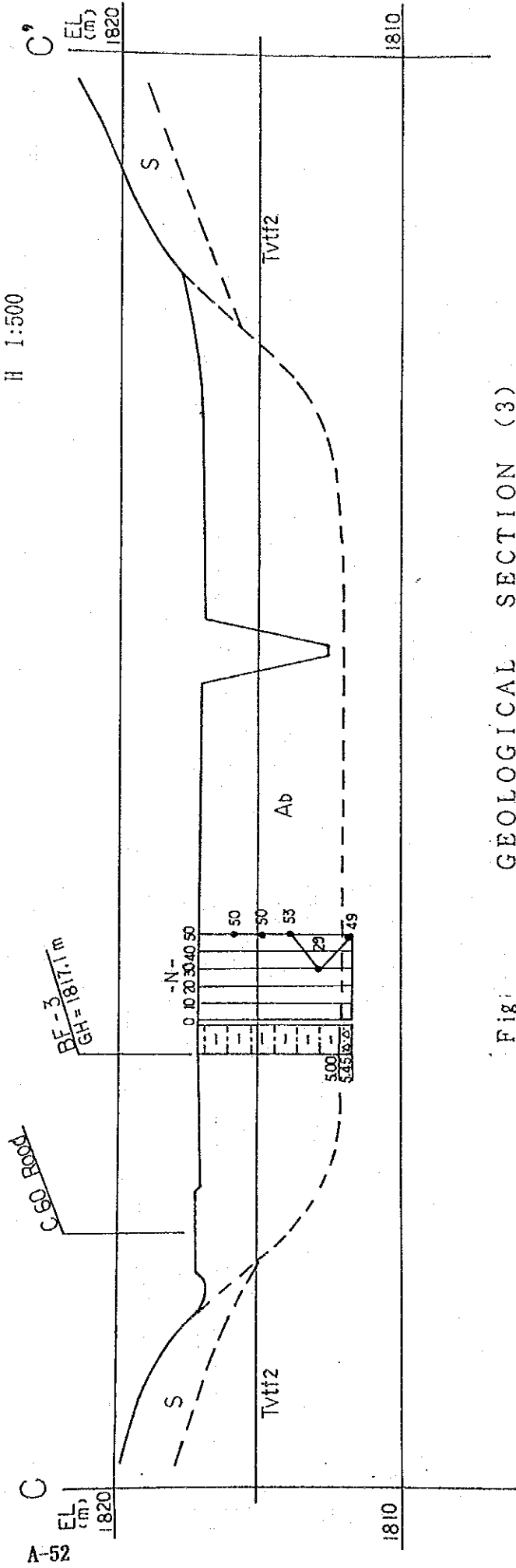
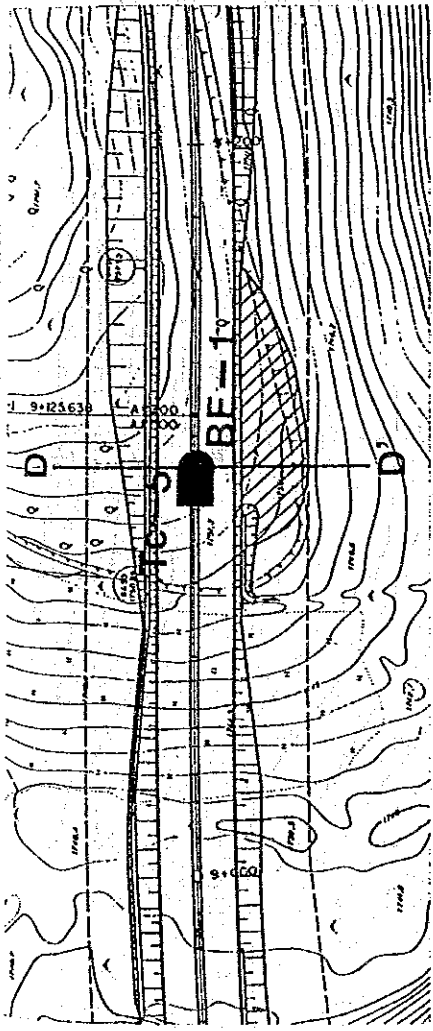

Fig. 3 GEOLOGICAL SECTION (3)



SCALE 1:2000

EL (m) 1760

EL (m) 1760

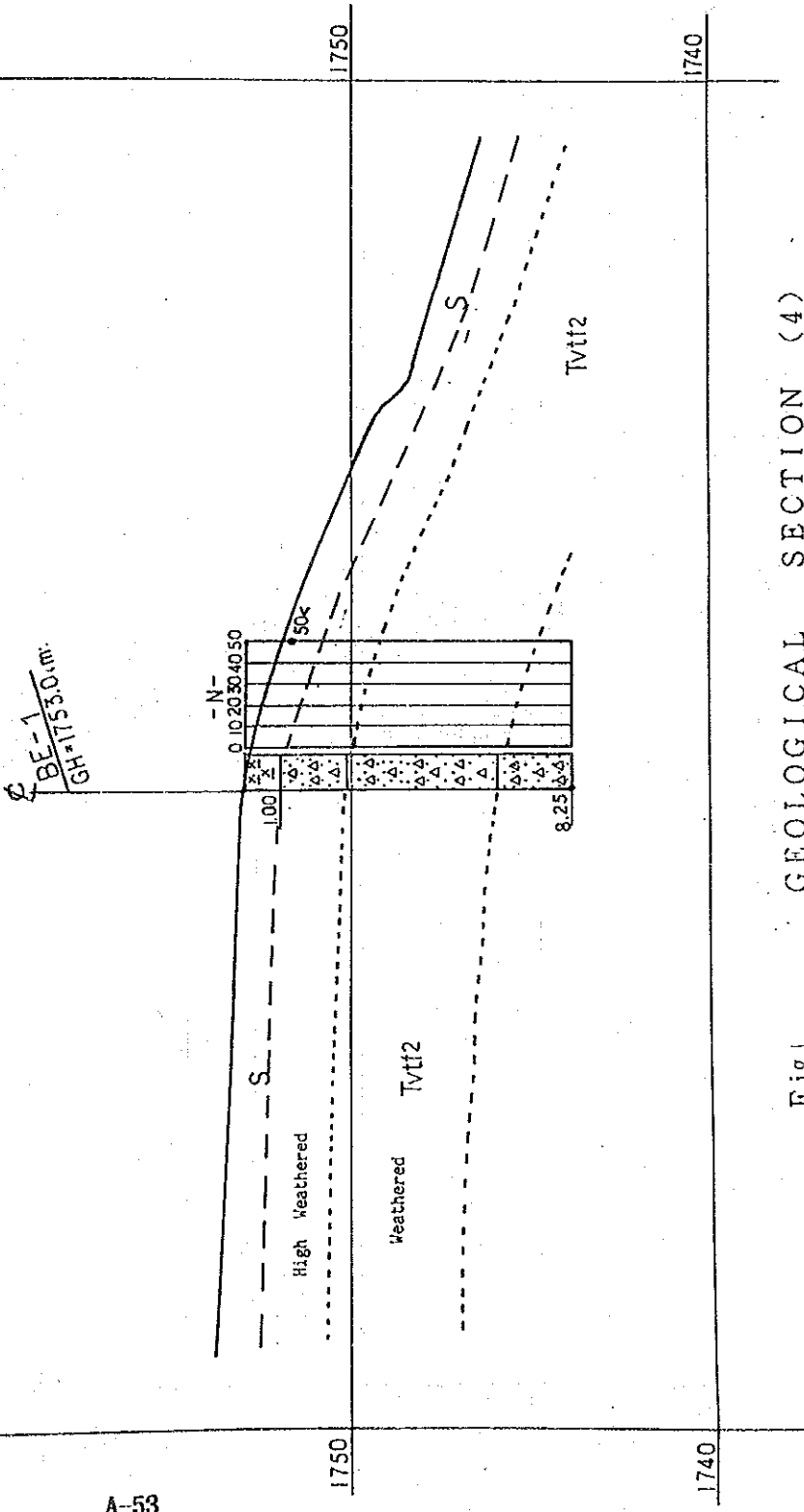

LEGEND

- S Red Soil
- Tvtf₂ Pyroclastic Tuff

V 1:200
SCALE H 1:500

Fig 1 GEOLOGICAL SECTION (4)

LEGEND



Red Soil

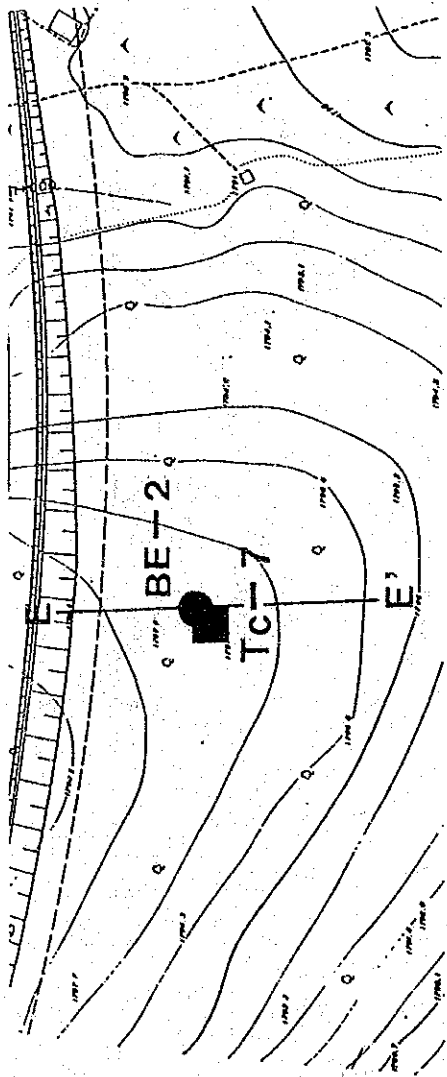

SCALE 1:2000

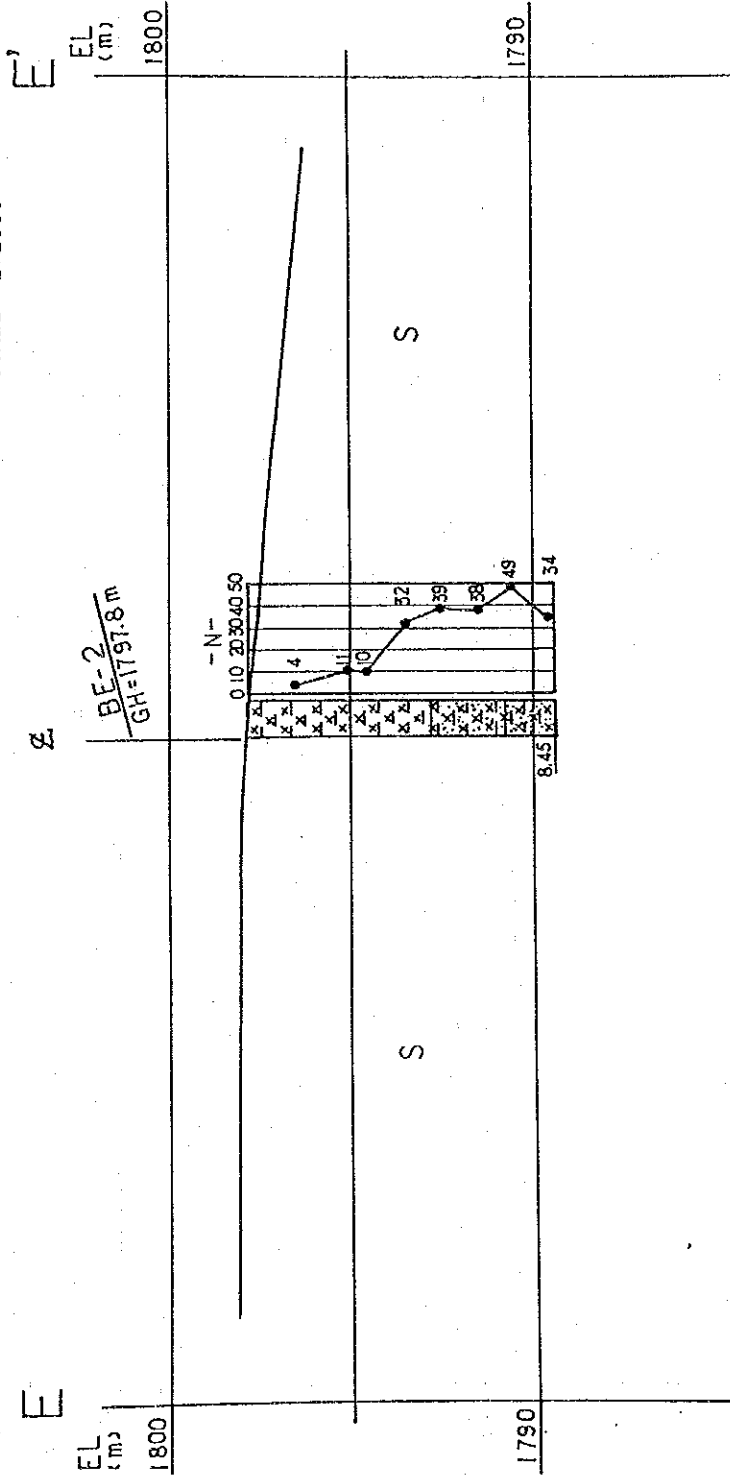

V 1:200

SCALE

H 1:500

Fig GEOLOGICAL SECTION (5)

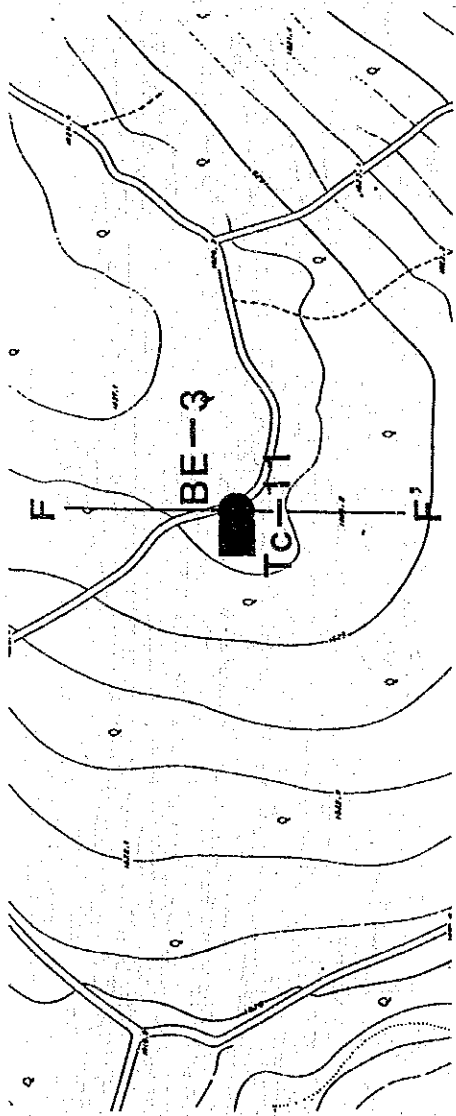

LEGEND

- S Red Soil
- Tvtf₂ Pyroclastic Tuff

SCALE 1:2000

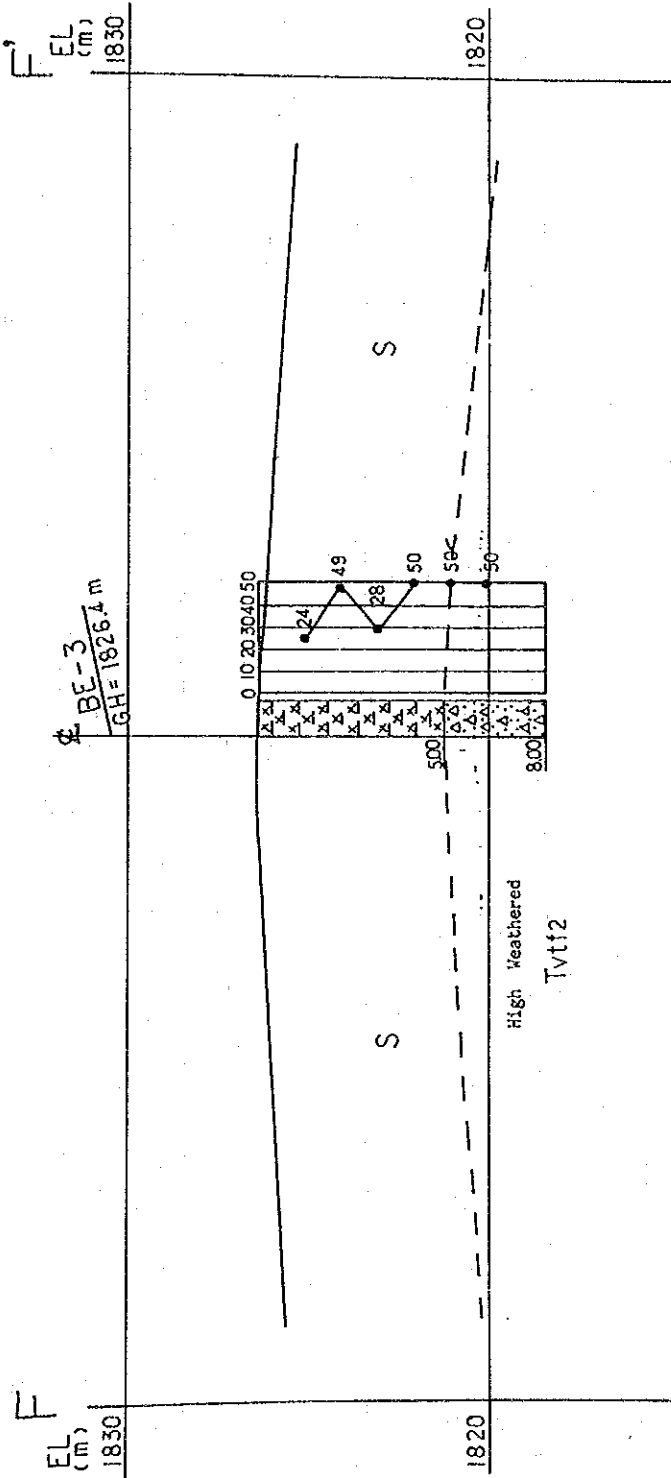

V 1:200
H 1:500
SCALE

Fig: GEOLOGICAL SECTION (6)

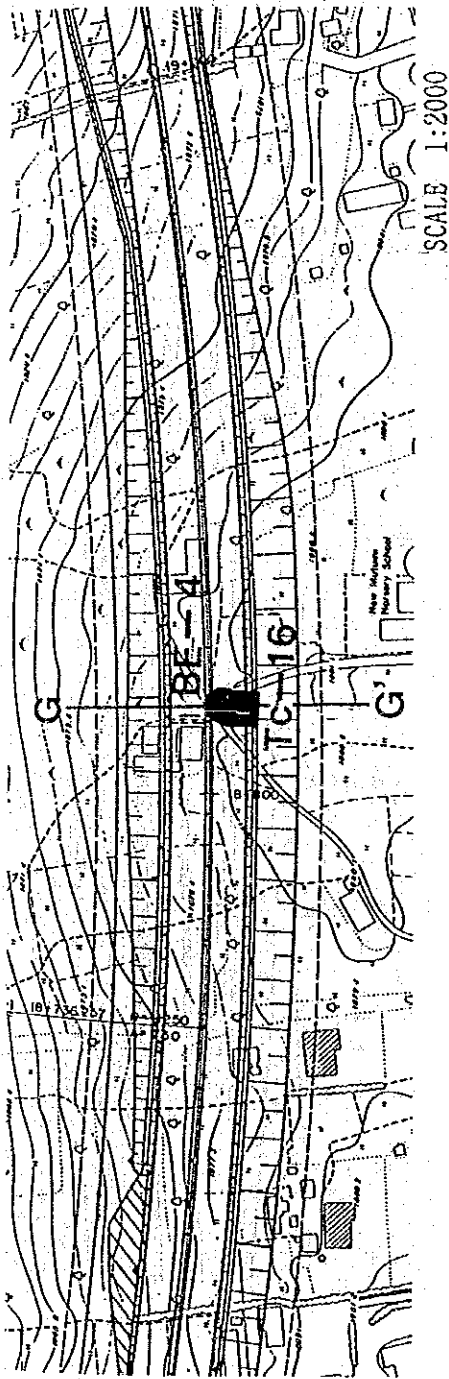

LEGEND

- S Red Soil
- Tvtf₂ High Weathered Pyroclastic Tuff
- Plh₁ Weathered Trachyte

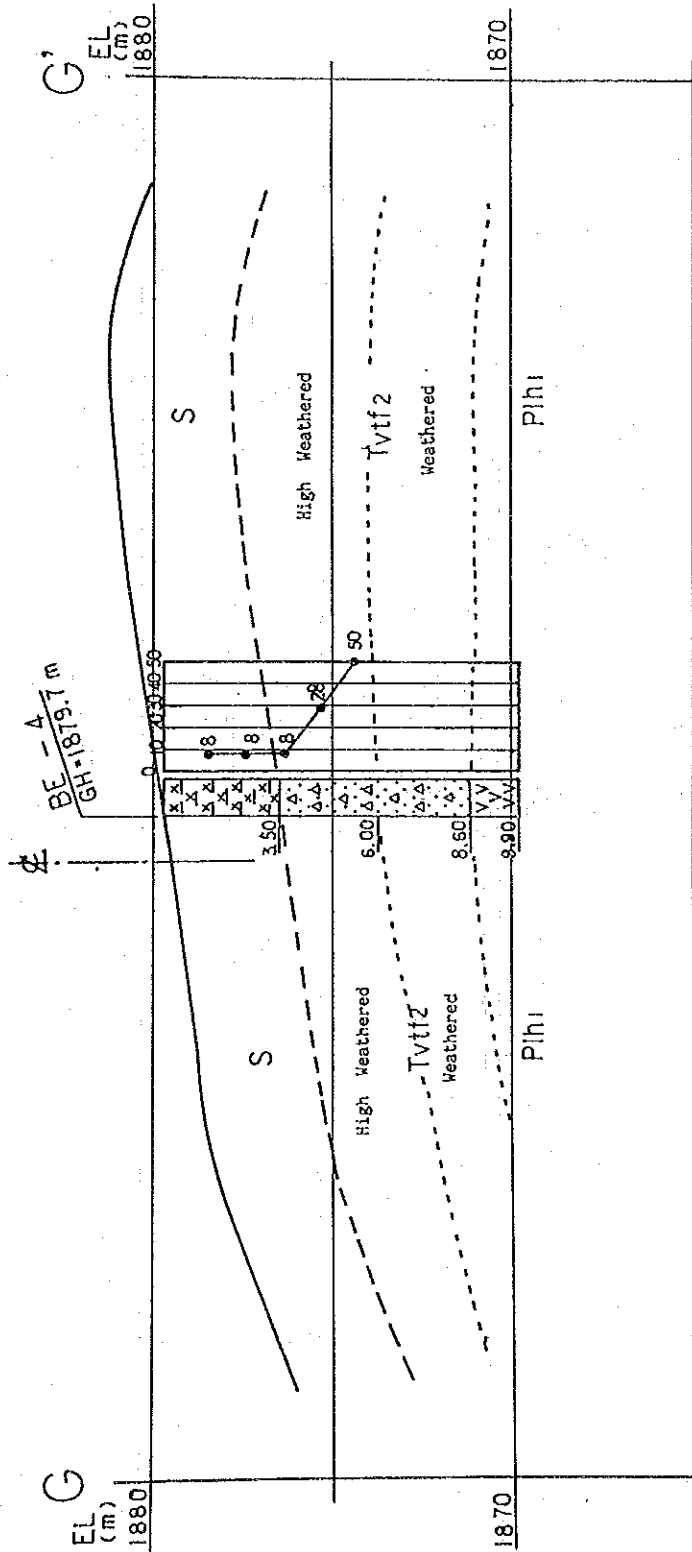

V 1:200
SCALE
H 1:500

Fig 1 GEOLOGICAL SECTION (7)

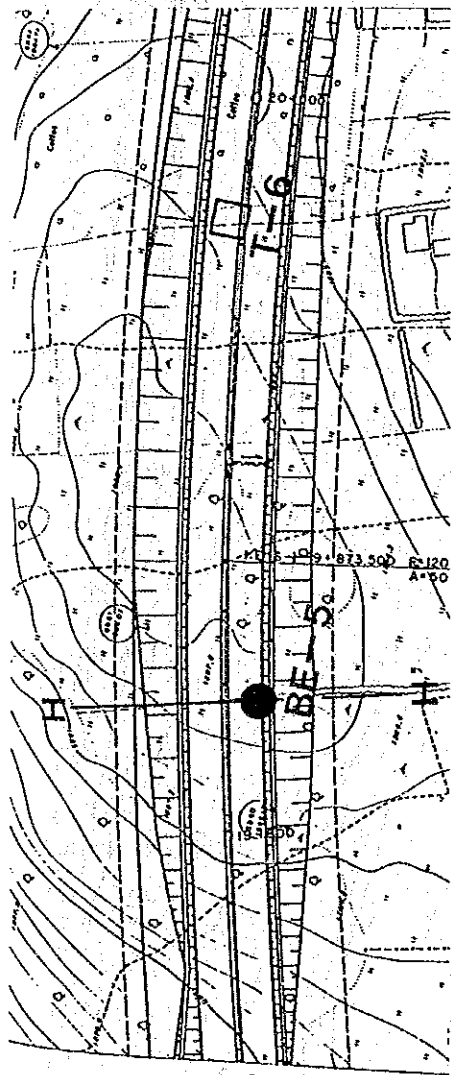

SCALE 1:2000

LEGEND

- S Red Soil
- Tvtf2 High Weathered and Weathered Pyroclastic Tuff

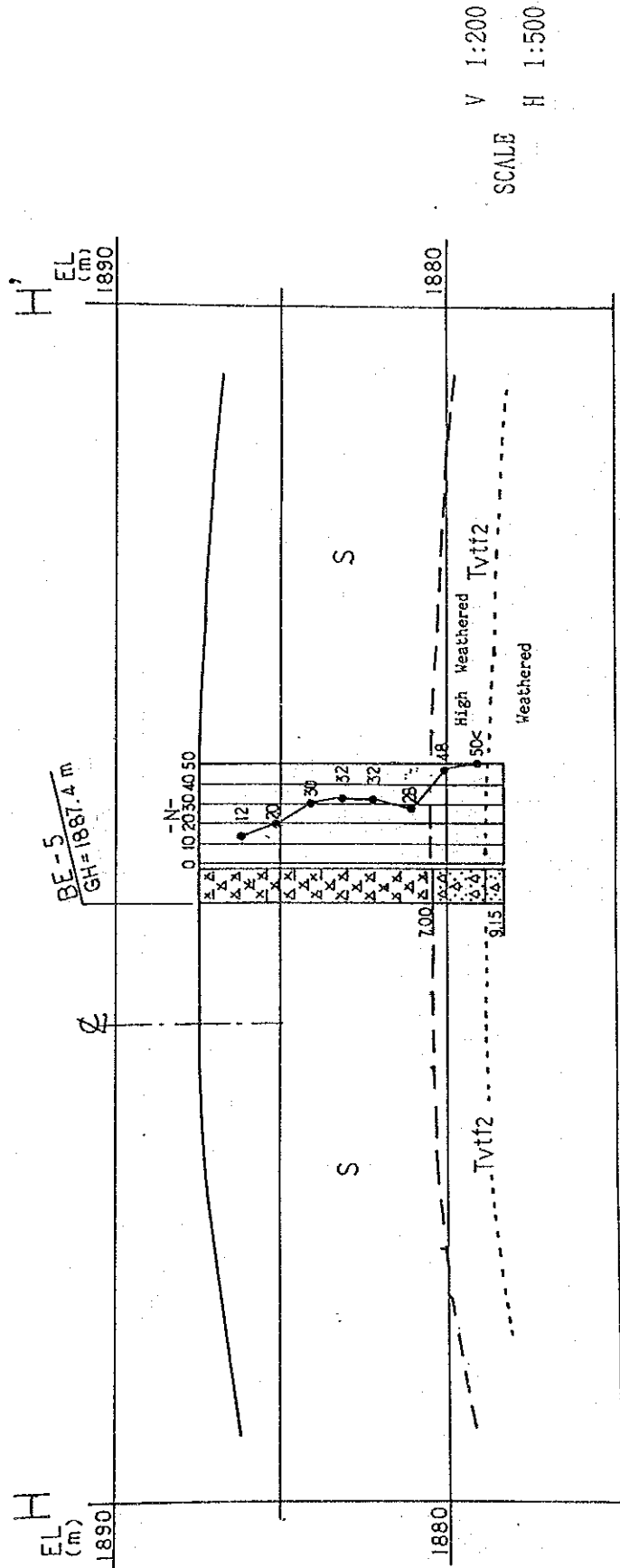
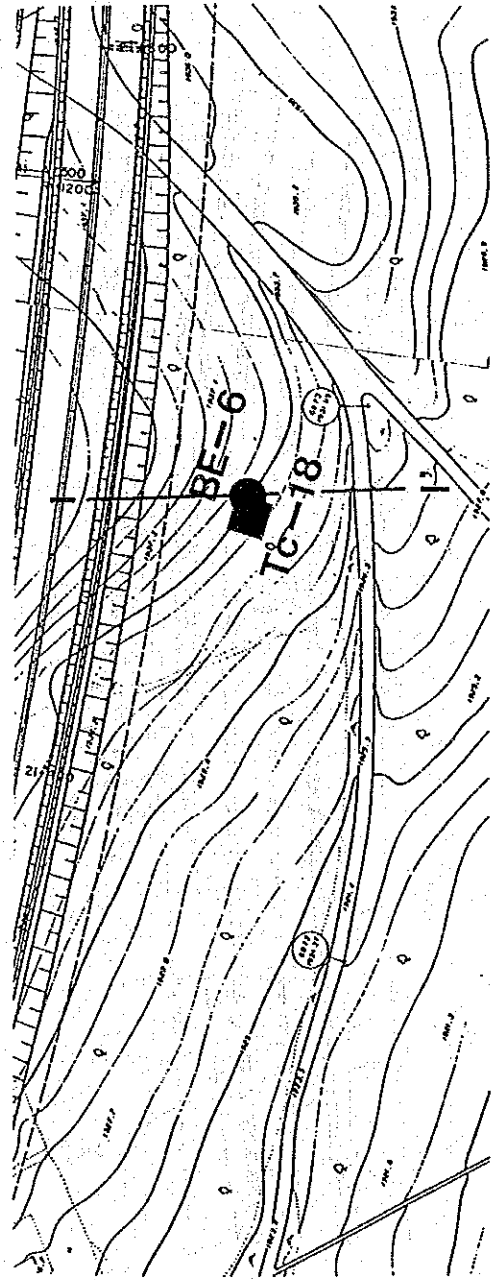

Fig GEOLOGICAL SECTION (8)

LEGEND

- S Red Soil
- Plh: High Weathered to Sound Trachyte



SCALE 1:2000

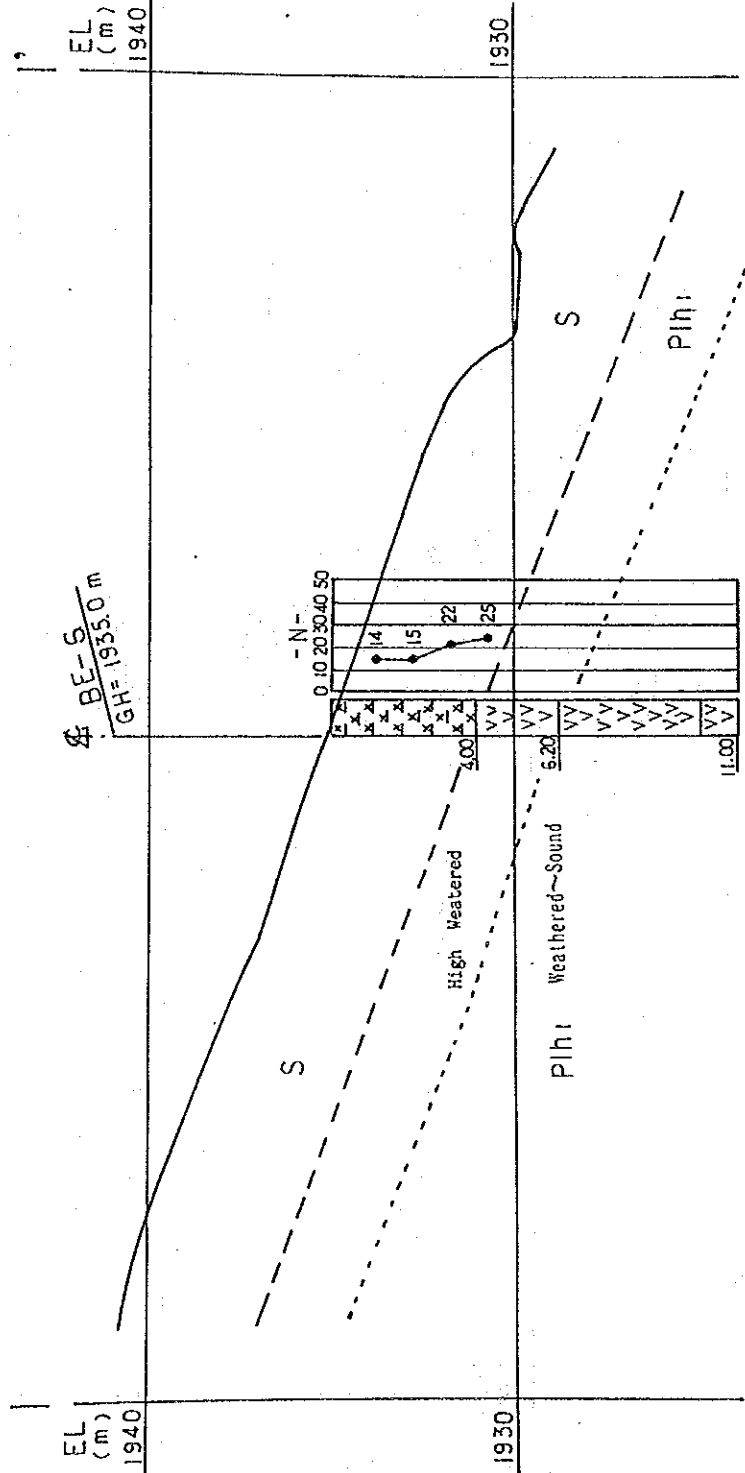

V 1:200
SCALE
H 1:500

FIG 8 GEOLOGICAL SECTION (8)

LEGEND

- S Red Soil
- PIh₁ High Weathered Trachyte

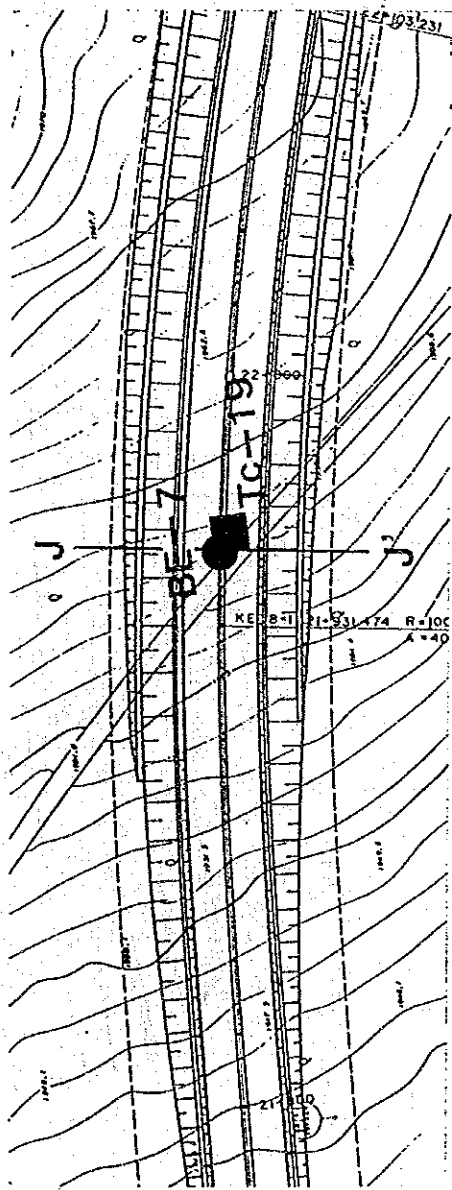

SCALE 1:2000

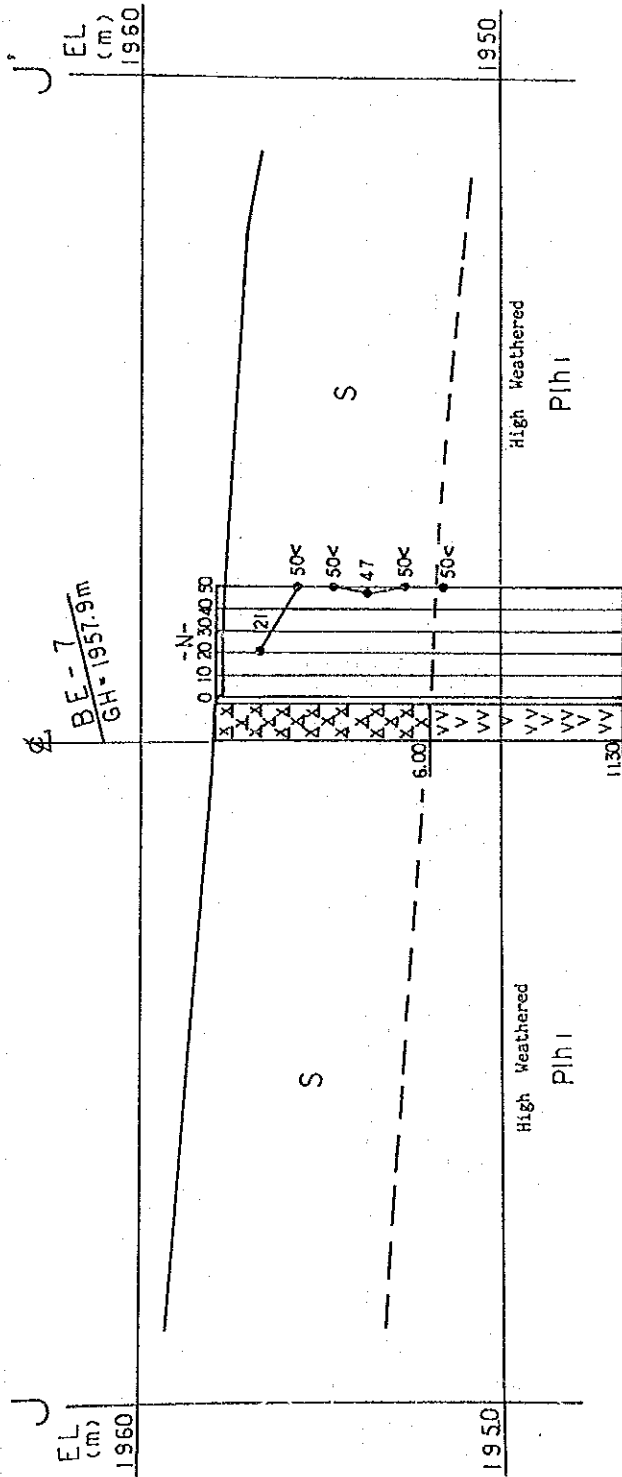

V 1:200
H 1:500
SCALE

Fig. GEOLOGICAL SECTION (10)

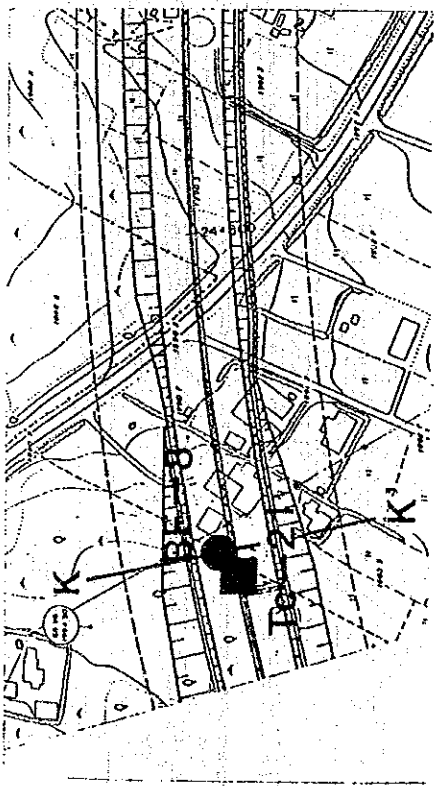

SCALE 1:2000

LEGEND

- S Red Soil
- Plh, High Weathered Trachyte

ELK
(m)

K'
EL
(m)
2000

2000

1990

BE-8
GH 1933.7m

42

0 0.20 30 40 50

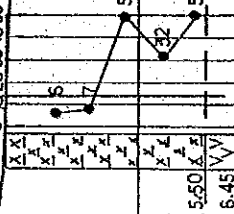

S

High Weathered Plh

SCALE
V 1:200
H 1:500

Fig GEOLOGICAL SECTION (11)

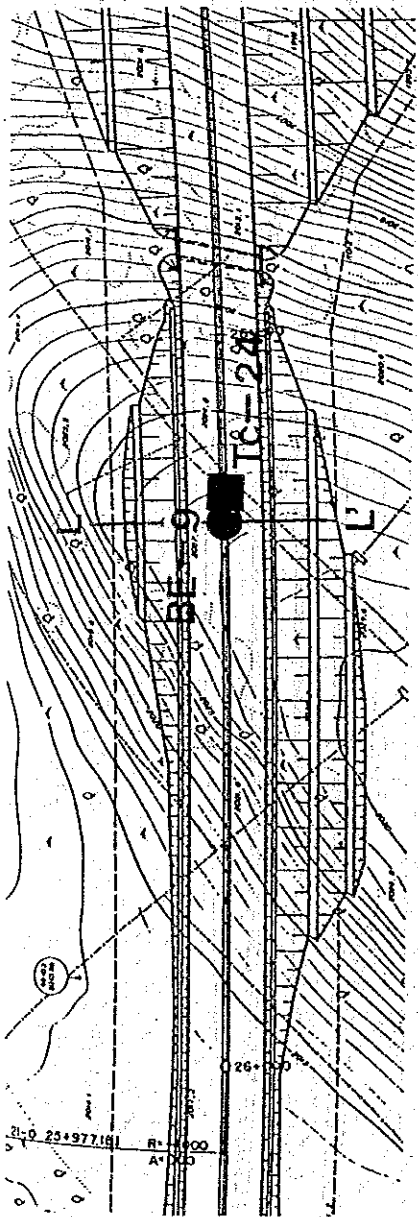

LEGEND

- S Red Soil
- Plh₁ High Weathered Trachyte

V 1:200
H 1:500
SCALE

SCALE 1:2000

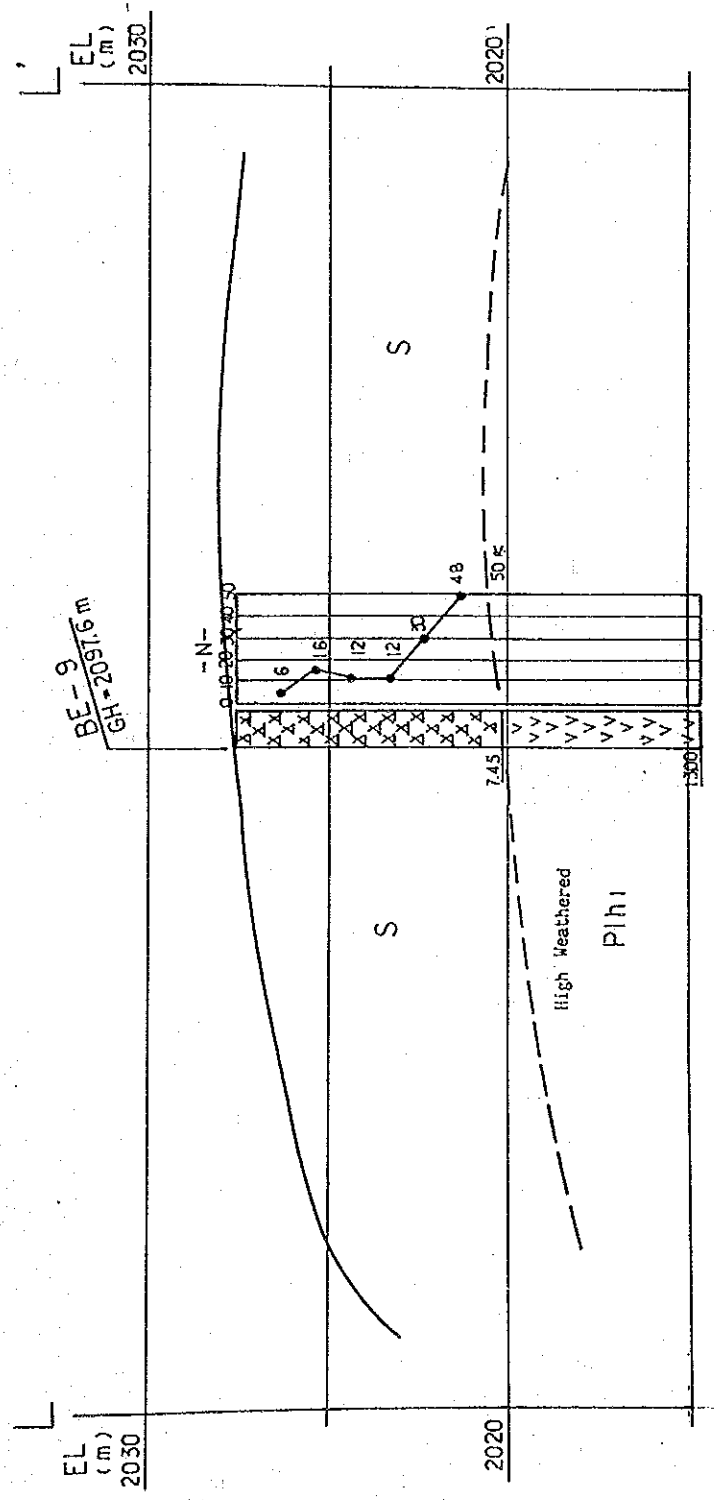
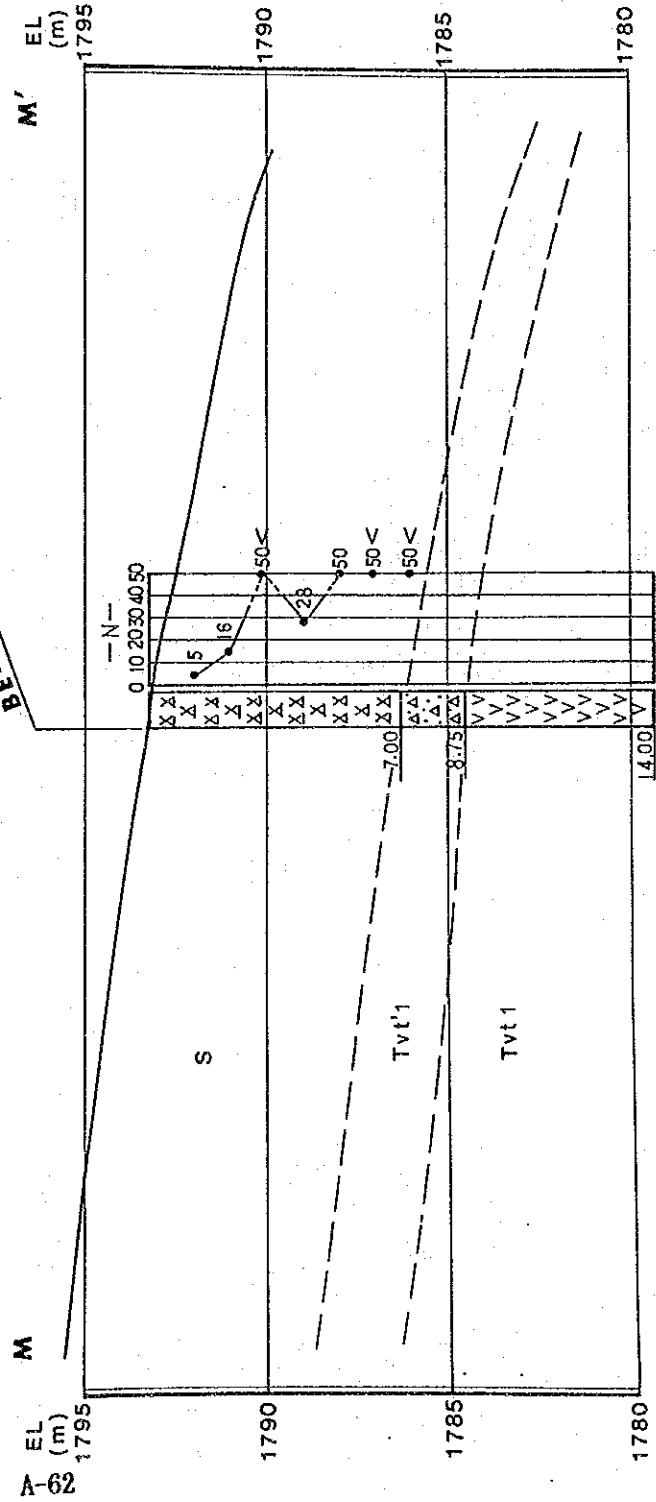
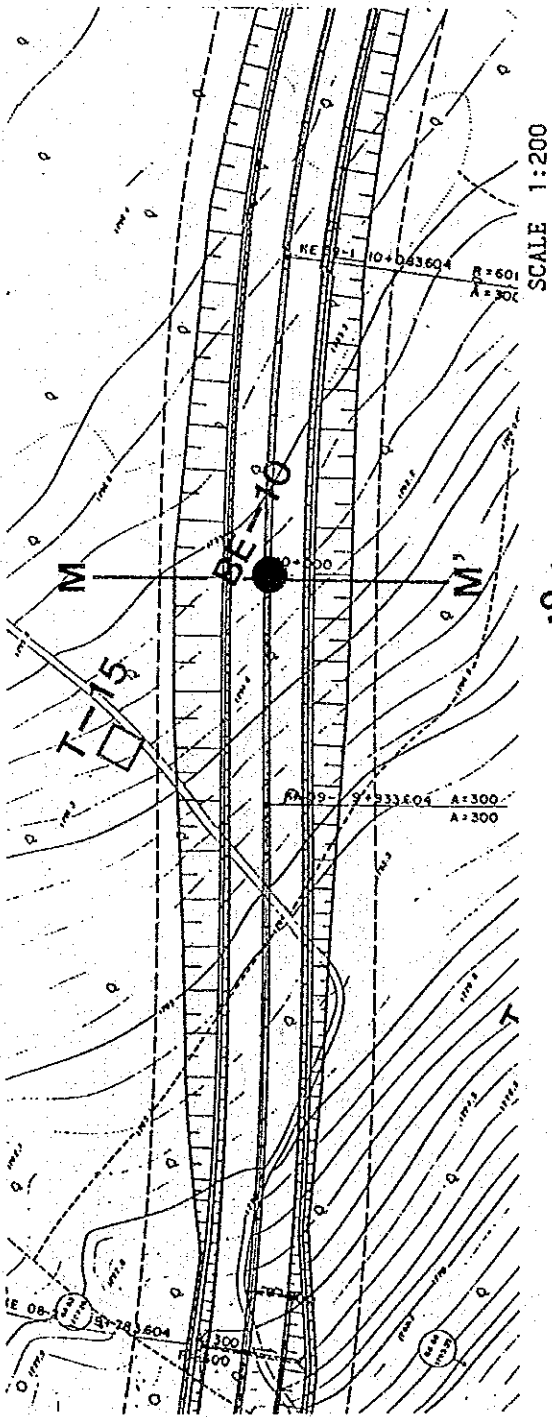

Fig GEOLOGICAL SECTION (12)



LEGEND

- S Red soil
- Tvt'1 Trachyte agglomerate
- Tvt 1 Trachyte (High weathered)

V = 1:200
SCALE H = 1:500

GEOLOGICAL SECTION (13)

Fig