

LEGEND	
	CHANNEL ALIGNMENT
	EXISTING DIKE
	NEW EARTH DIKE
	NEW PARAPET WALL
	LOW WATER CHANNEL ALIGNMENT
	REVETMENT
	NEW IRRIGATION CANAL
	SLUICE WAY
	WATER GATE
	BRIDGE (TO BE CONSTRUCTED)
	WEIR
	INUNDATION AREA

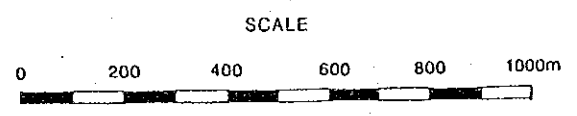
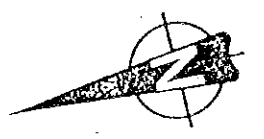

THE STUDY ON BELAWAN-INDANG INTEGRATED RIVER BASIN DEVELOPMENT
 IN THE REPUBLIC OF INDONESIA
 JAPAN INTERNATIONAL COOPERATION AGENCY

ALIGNMENT AND TYPICAL CROSS SECTION OF
 PROPOSED PERCUT RIVER IMPROVEMENT
 WORKS

Fig. 3-8. (3/3)

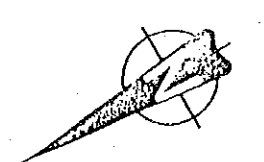
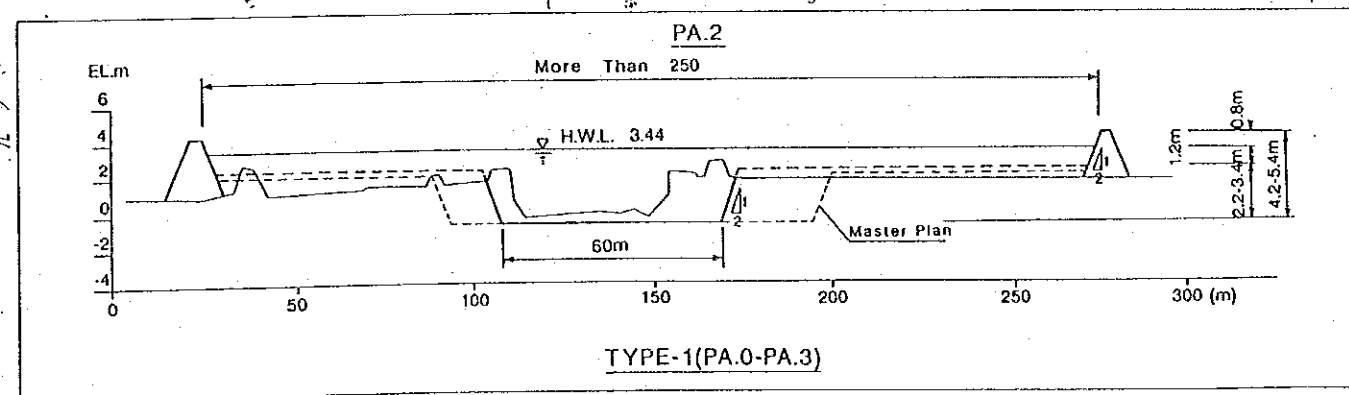
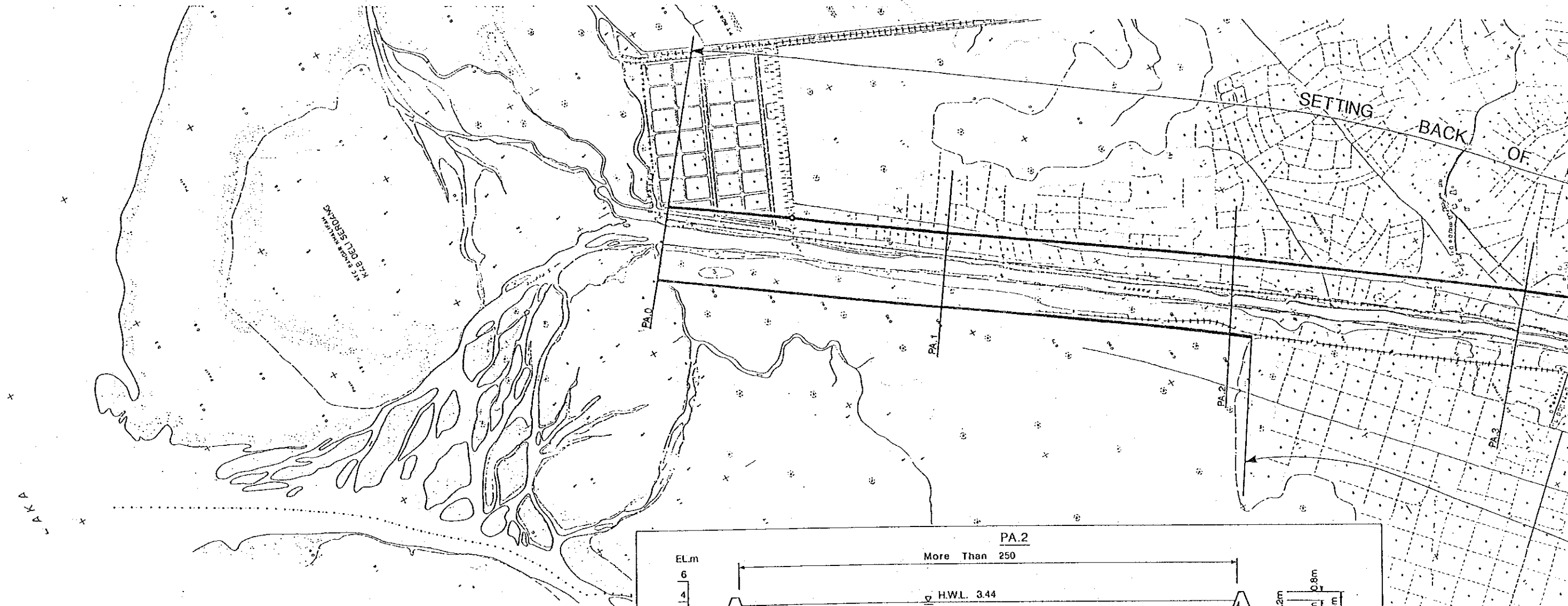
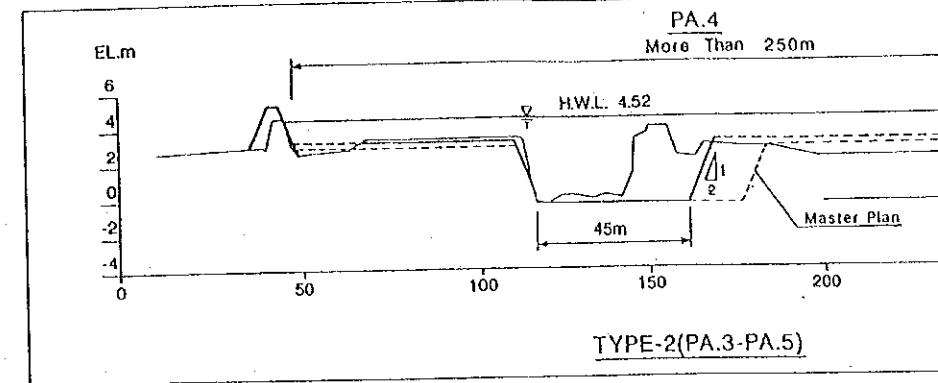
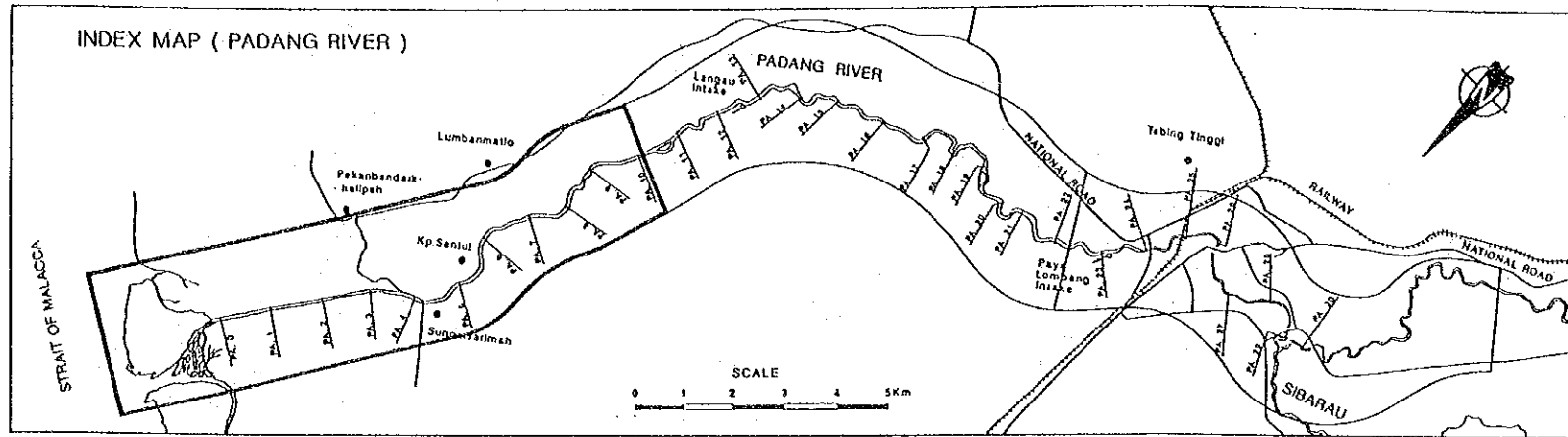

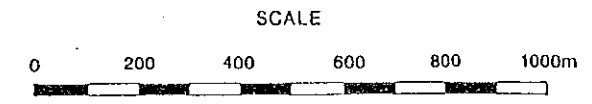
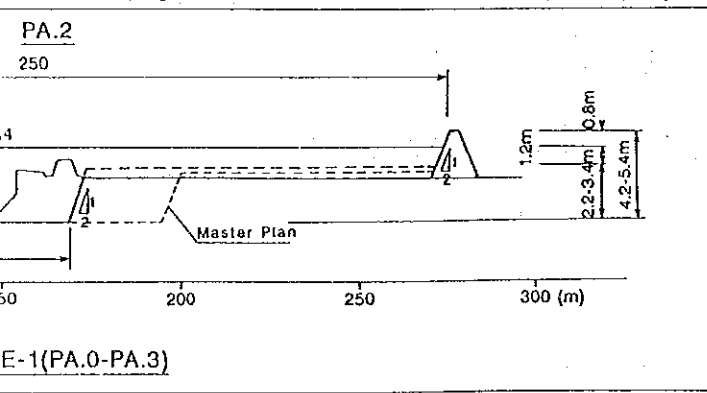
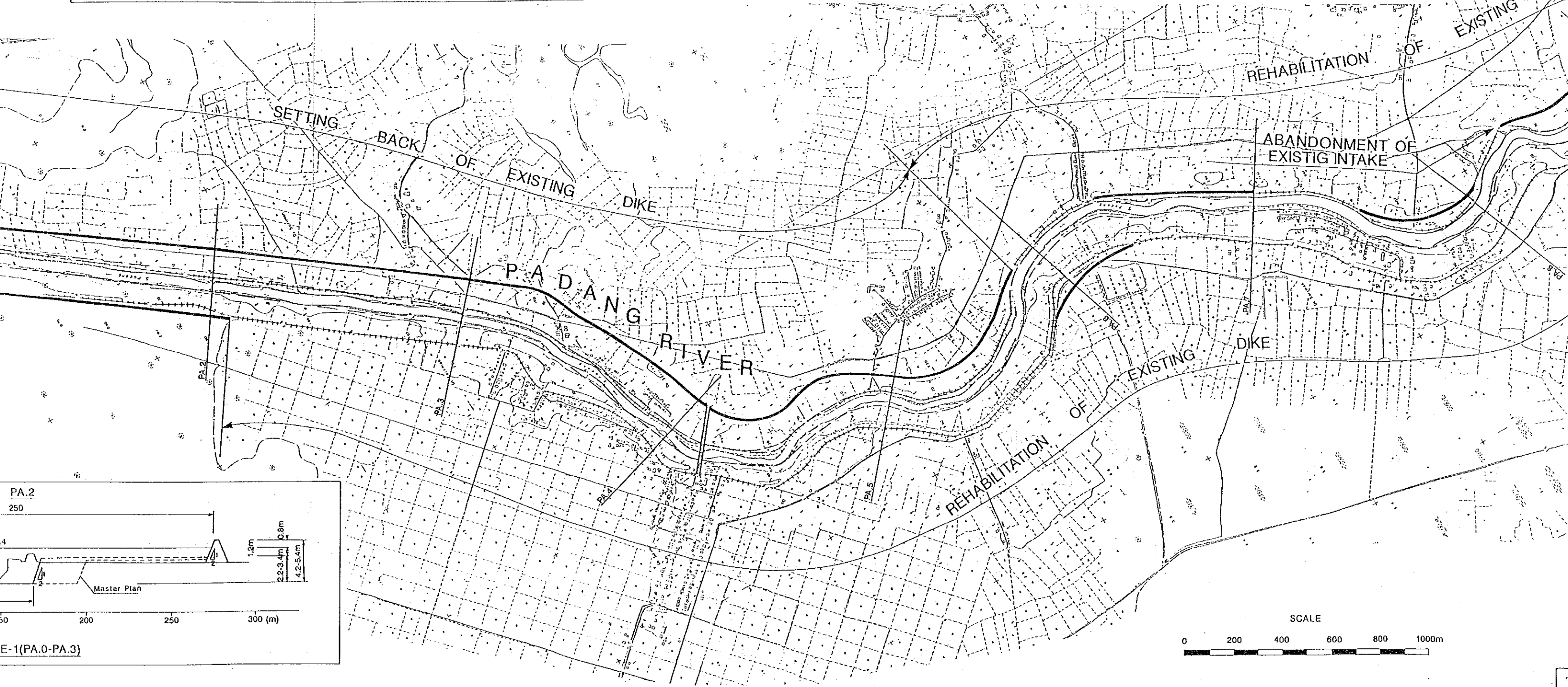
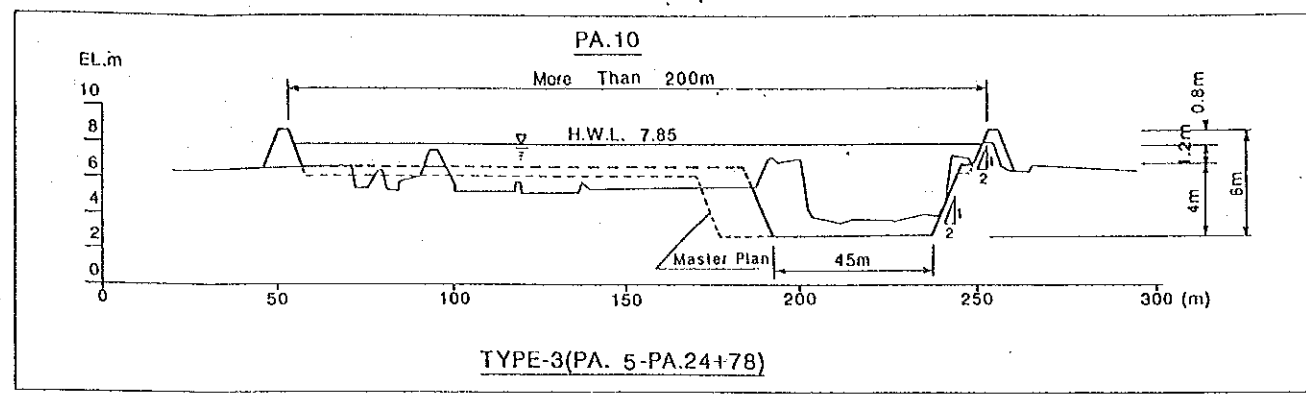
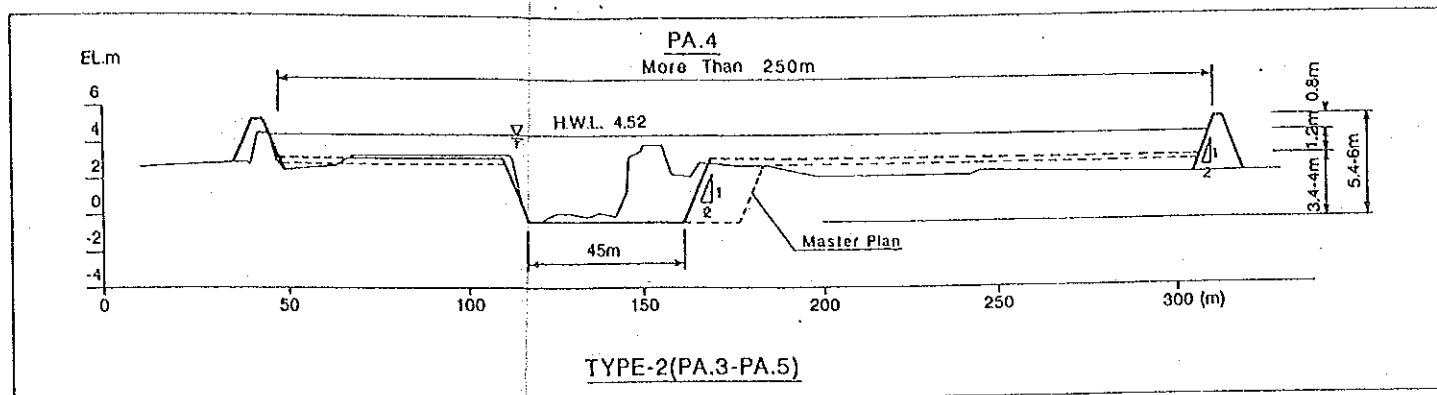

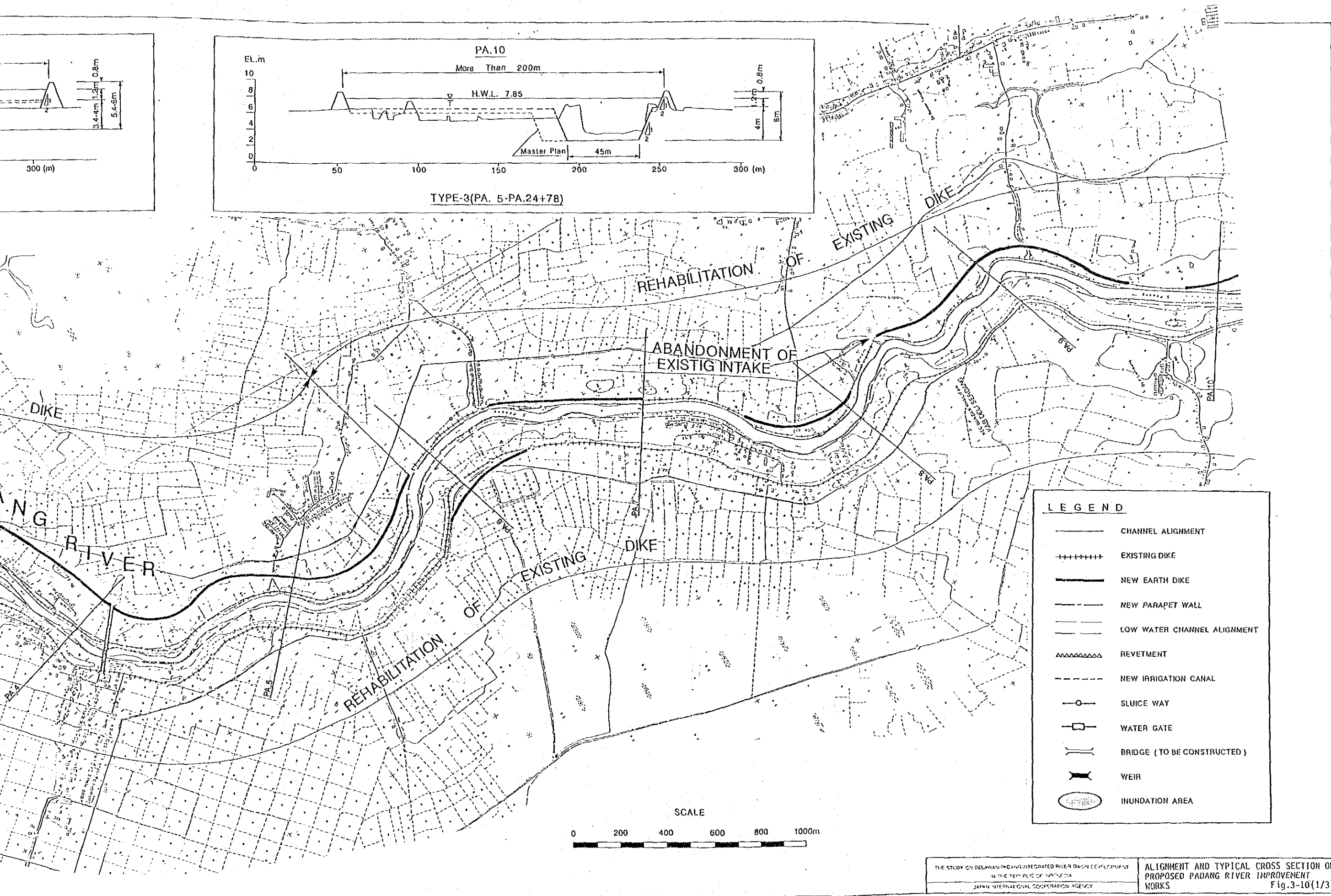
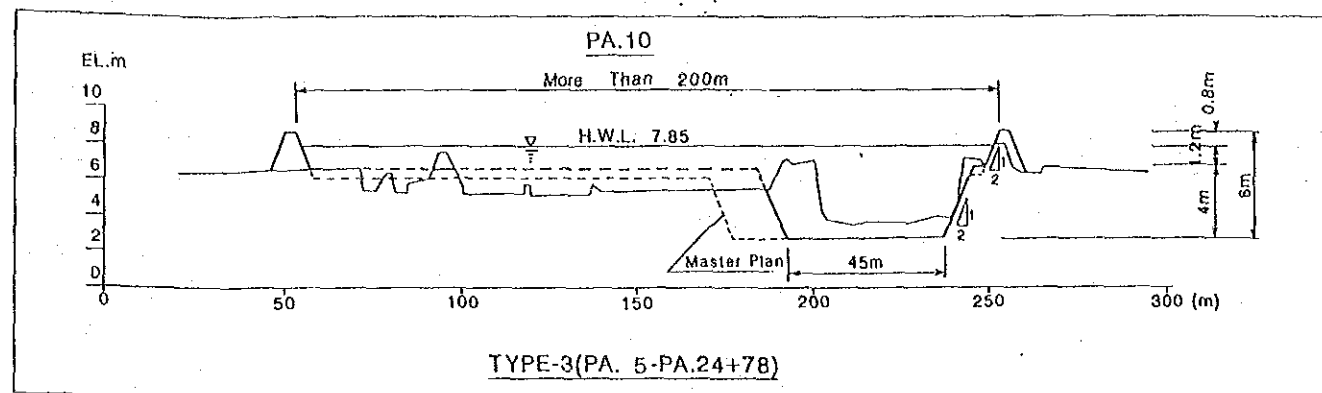
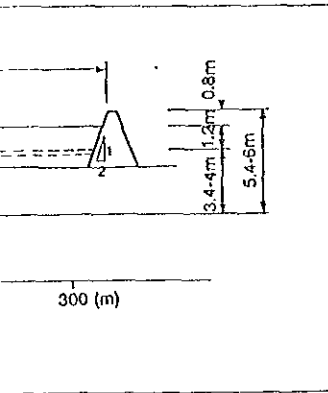

LEGEND	
	CHANNEL ALIGNMENT
	EXISTING DIKE
	NEW EARTH DIKE
	NEW PARAPET WALL
	LOW WATER CHANNEL ALIGNMENT
	REVTMENT
	NEW IRRIGATION CANAL
	SLUICE WAY
	WATER GATE
	BRIDGE (TO BE CONSTRUCTED)
	WEIR
	INUNDATION AREA

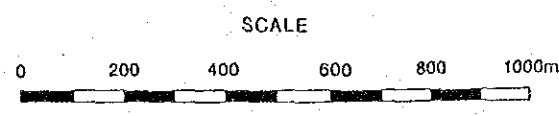

THE STUDY ON BELAWAN INTEGRATED RIVER BASIN DEVELOPMENT
IN THE REPUBLIC OF INDONESIA
JAPAN INTERNATIONAL COOPERATION AGENCY

ALIGNMENT AND TYPICAL CROSS SECTION OF
PROPOSED PADANG RIVER IMPROVEMENT
WORKS
Fig.3-10(1/3)

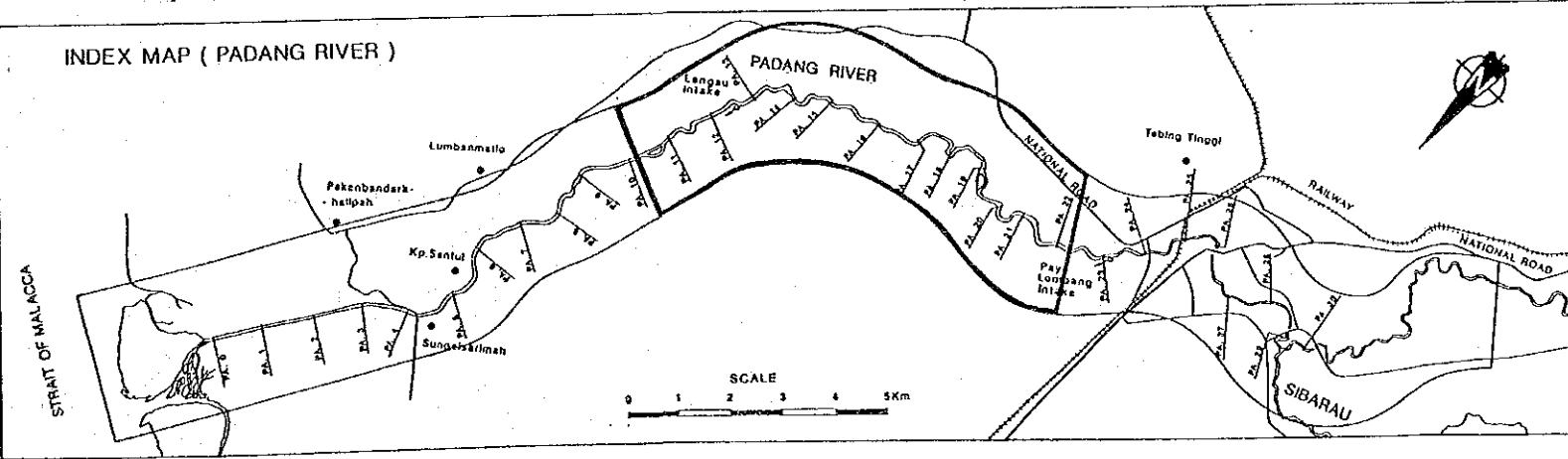
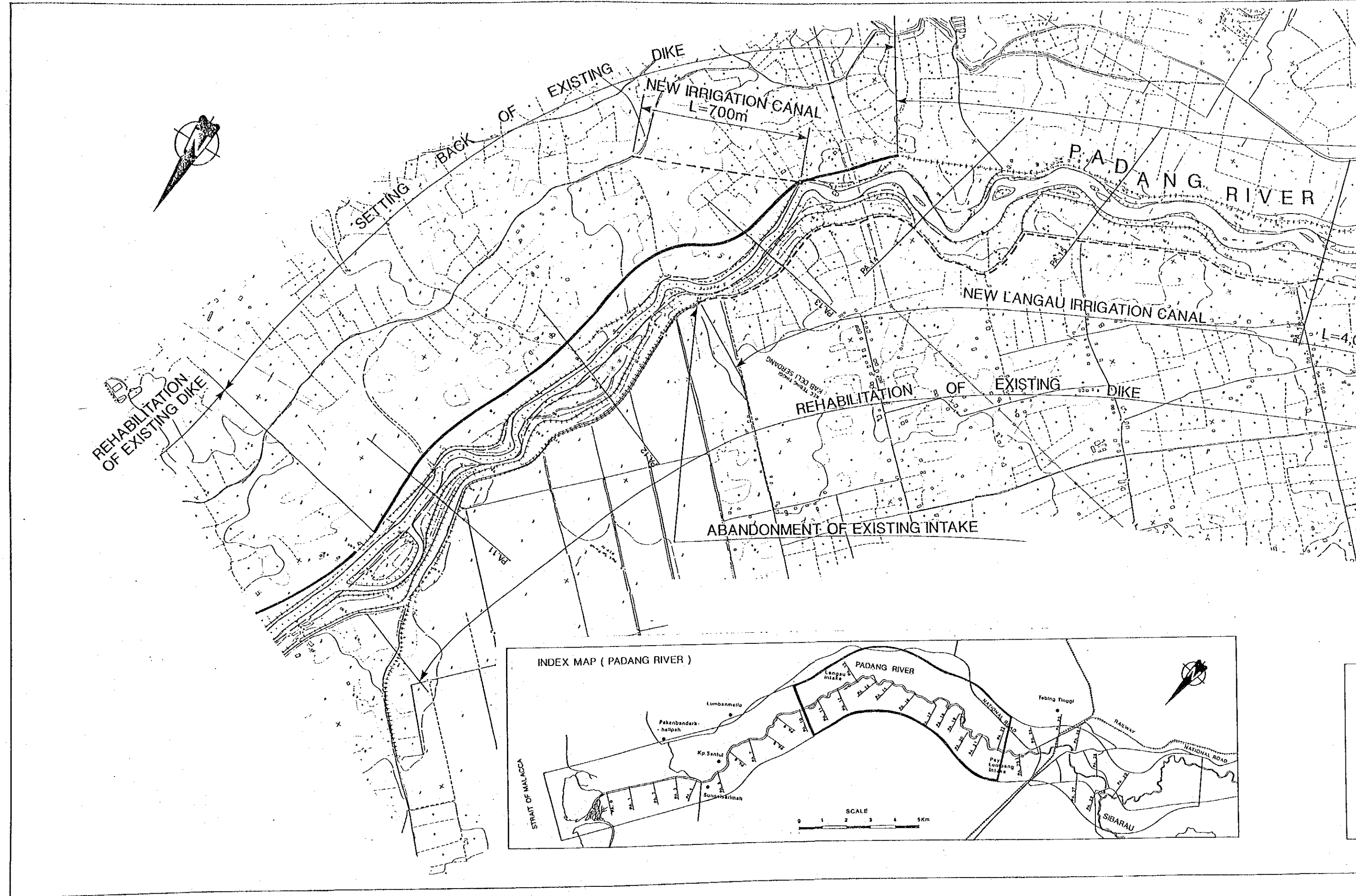

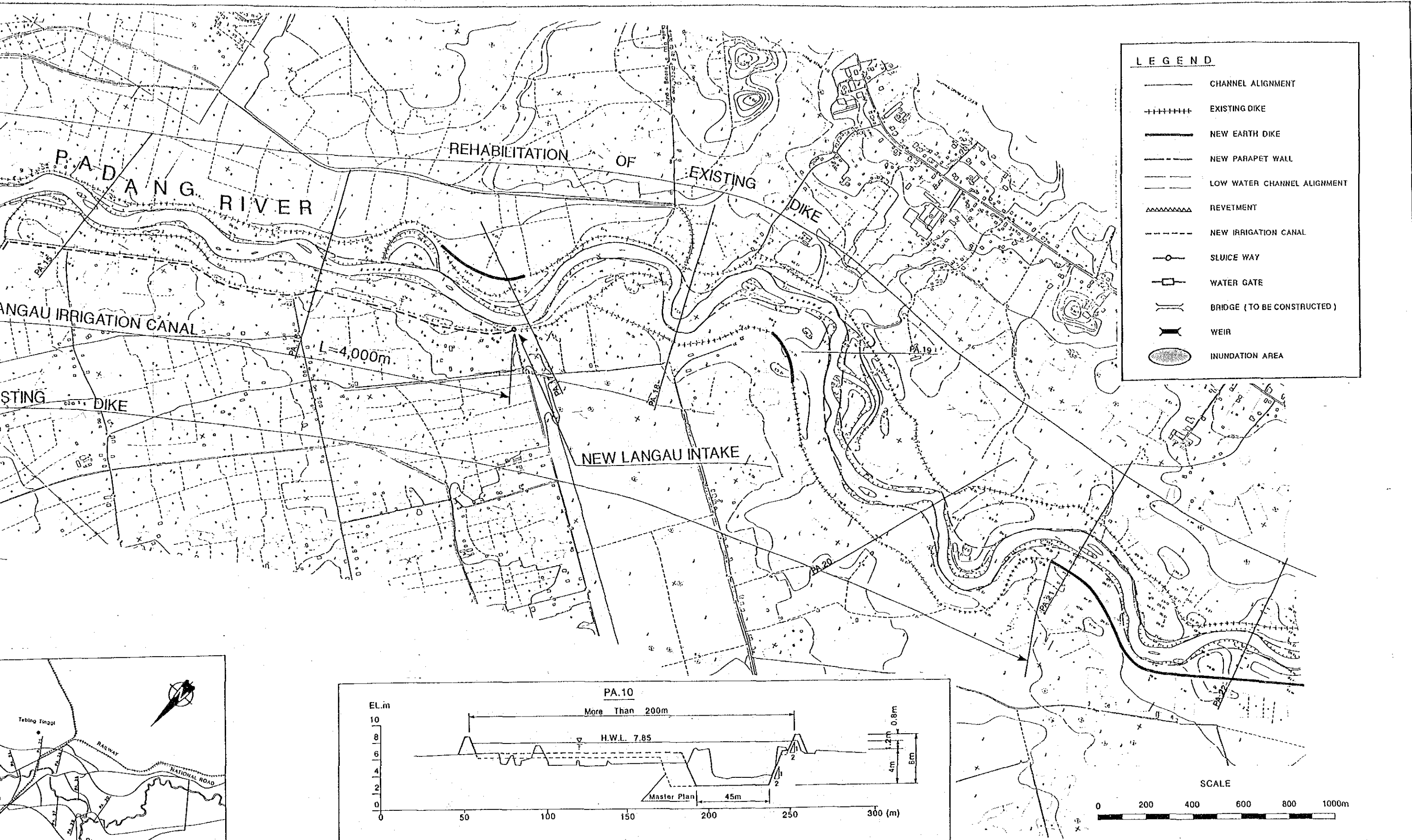

LEGEND	
	CHANNEL ALIGNMENT
	EXISTING DIKE
	NEW EARTH DIKE
	NEW PARAPET WALL
	LOW WATER CHANNEL ALIGNMENT
	REVETMENT
	NEW IRRIGATION CANAL
	SLUICE WAY
	WATER GATE
	BRIDGE (TO BE CONSTRUCTED)
	WEIR
	INUNDATION AREA

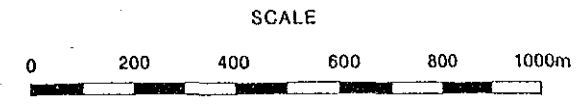
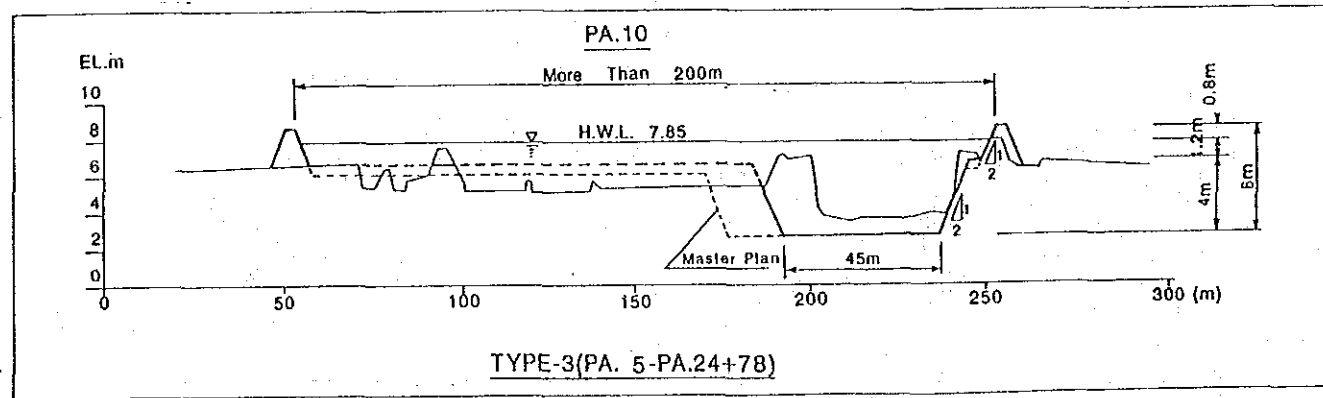
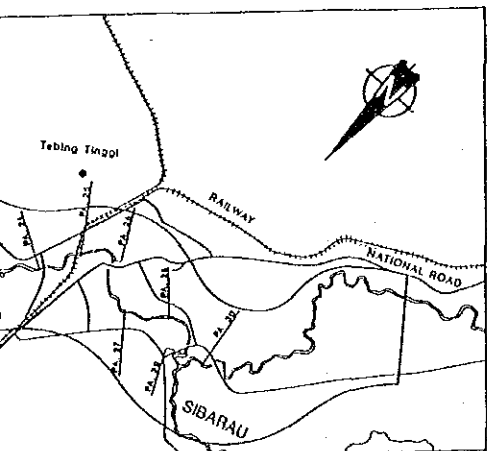

THE STUDY ON EELWANG-PADANG INTEGRATED RIVER BASIN DEVELOPMENT
 IN THE REPUBLIC OF INDONESIA
 JAPAN INTERNATIONAL COOPERATION AGENCY

ALIGNMENT AND TYPICAL CROSS SECTION OF
 PROPOSED PADANG RIVER IMPROVEMENT
 WORKS
 Fig.3-10 (2/3)

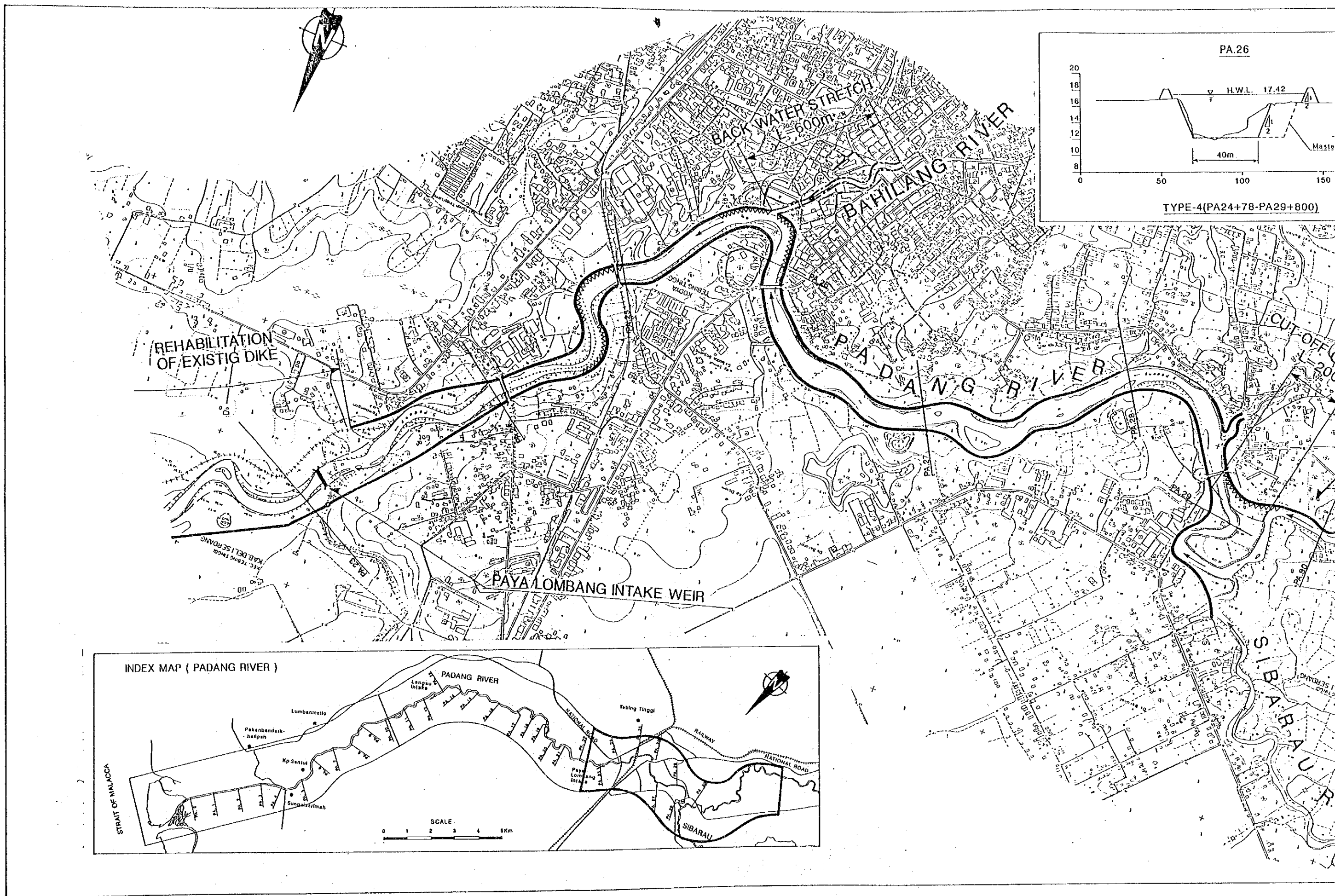

PA.26

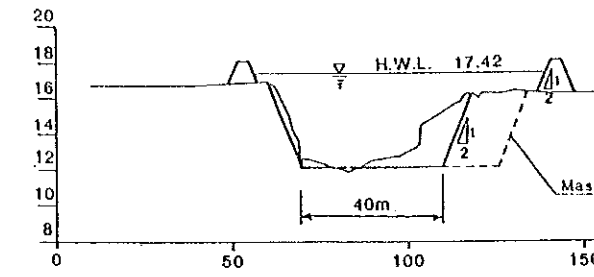

TYPE-4(PA24+78-PA29+800)

REHABILITATION OF EXISTING DIKE

BACK-WATER STRETCH 600m

BAHILANG RIVER

PADANG RIVER

PAYA LOMBANG INTAKE WEIR

CUT-OFF

SIBARAU

INDEX MAP (PADANG RIVER)

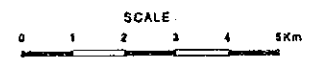
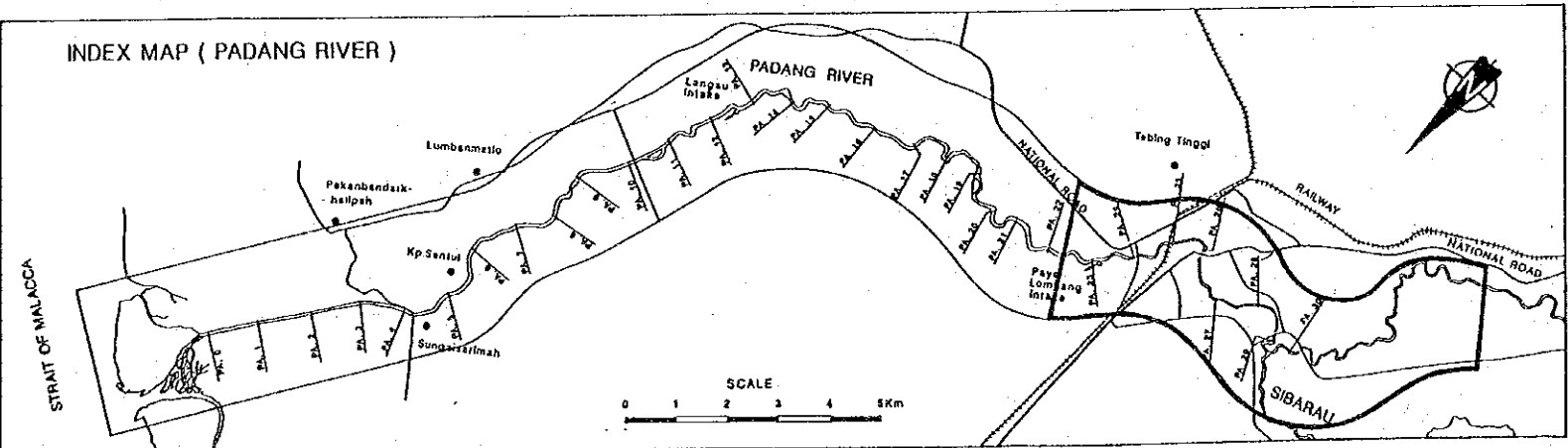

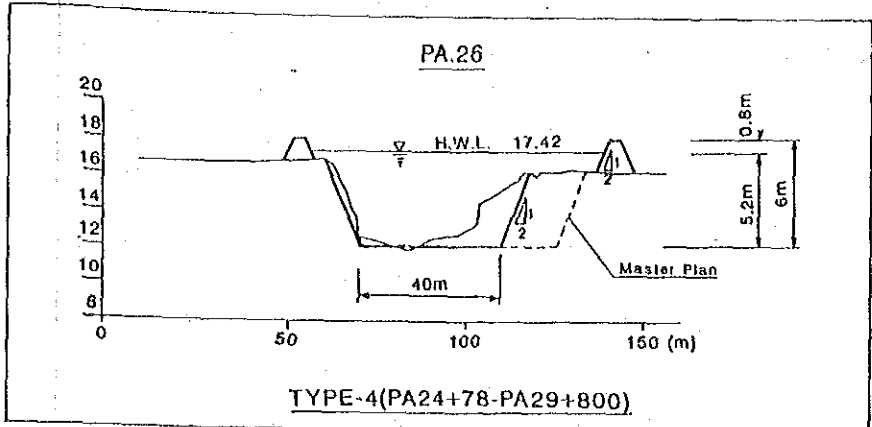
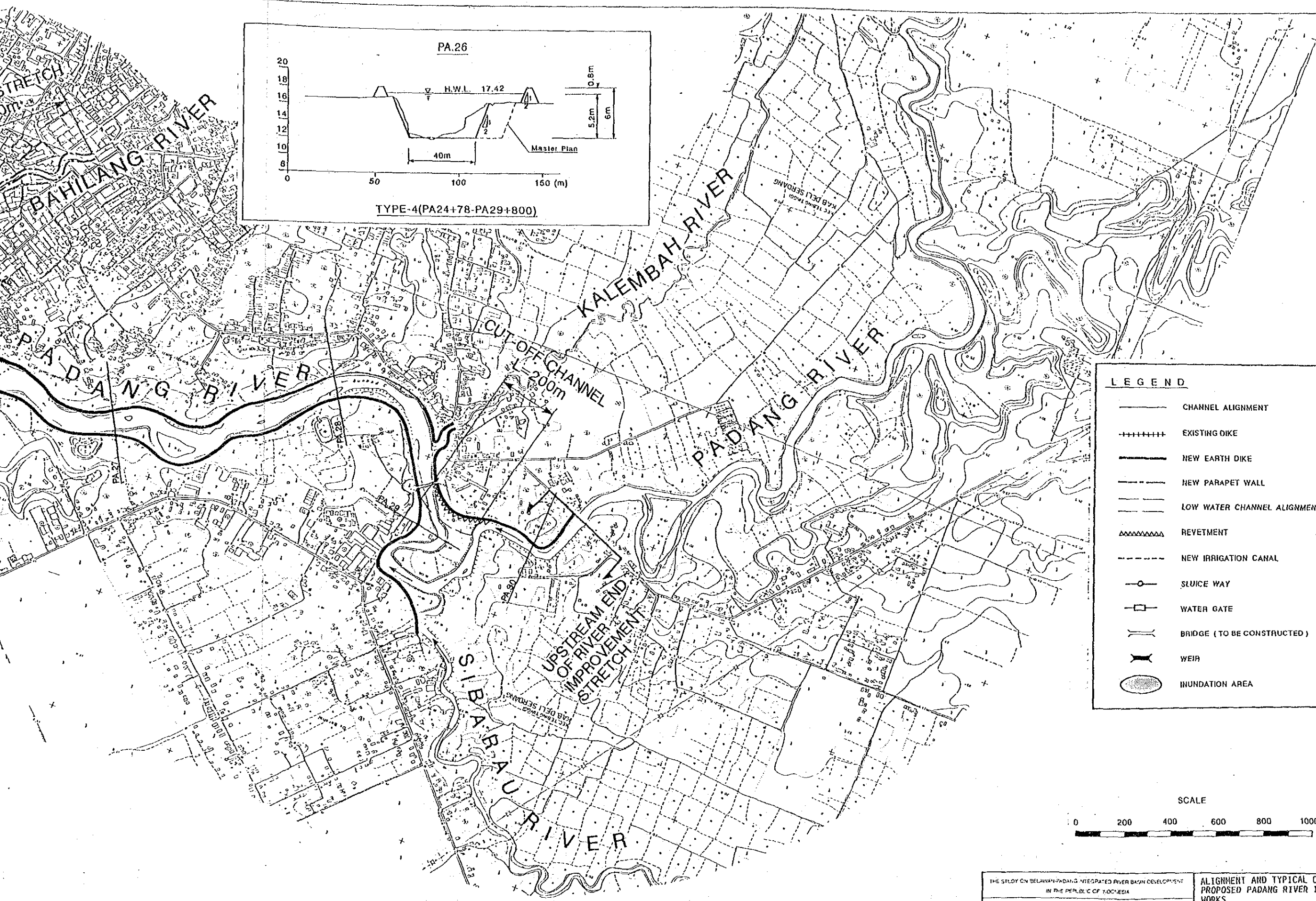

LEGEND	
	CHANNEL ALIGNMENT
	EXISTING DIKE
	NEW EARTH DIKE
	NEW PARAPET WALL
	LOW WATER CHANNEL ALIGNMENT
	REVETMENT
	NEW IRRIGATION CANAL
	SLUICE WAY
	WATER GATE
	BRIDGE (TO BE CONSTRUCTED)
	WEIR
	INUNDATION AREA

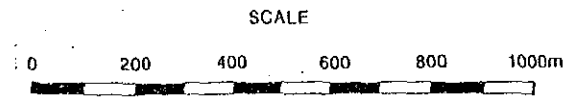

THE STUDY ON BELAWAH-PADANG INTEGRATED RIVER BASIN DEVELOPMENT
 IN THE REPUBLIC OF INDONESIA
 JAPAN INTERNATIONAL COOPERATION AGENCY

ALIGNMENT AND TYPICAL CROSS SECTION OF
 PROPOSED PADANG RIVER IMPROVEMENT
 WORKS
 Fig.3-10(3/3)

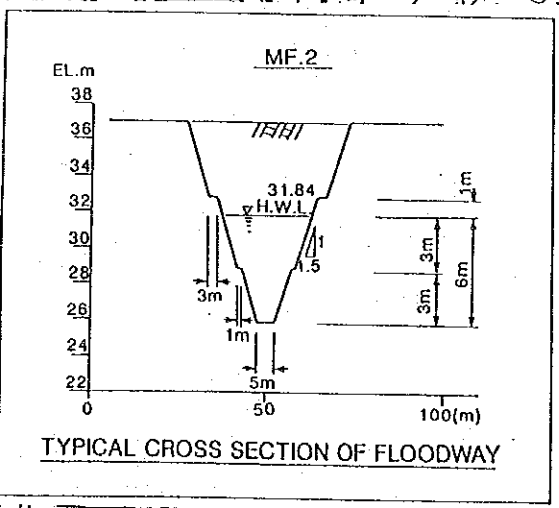
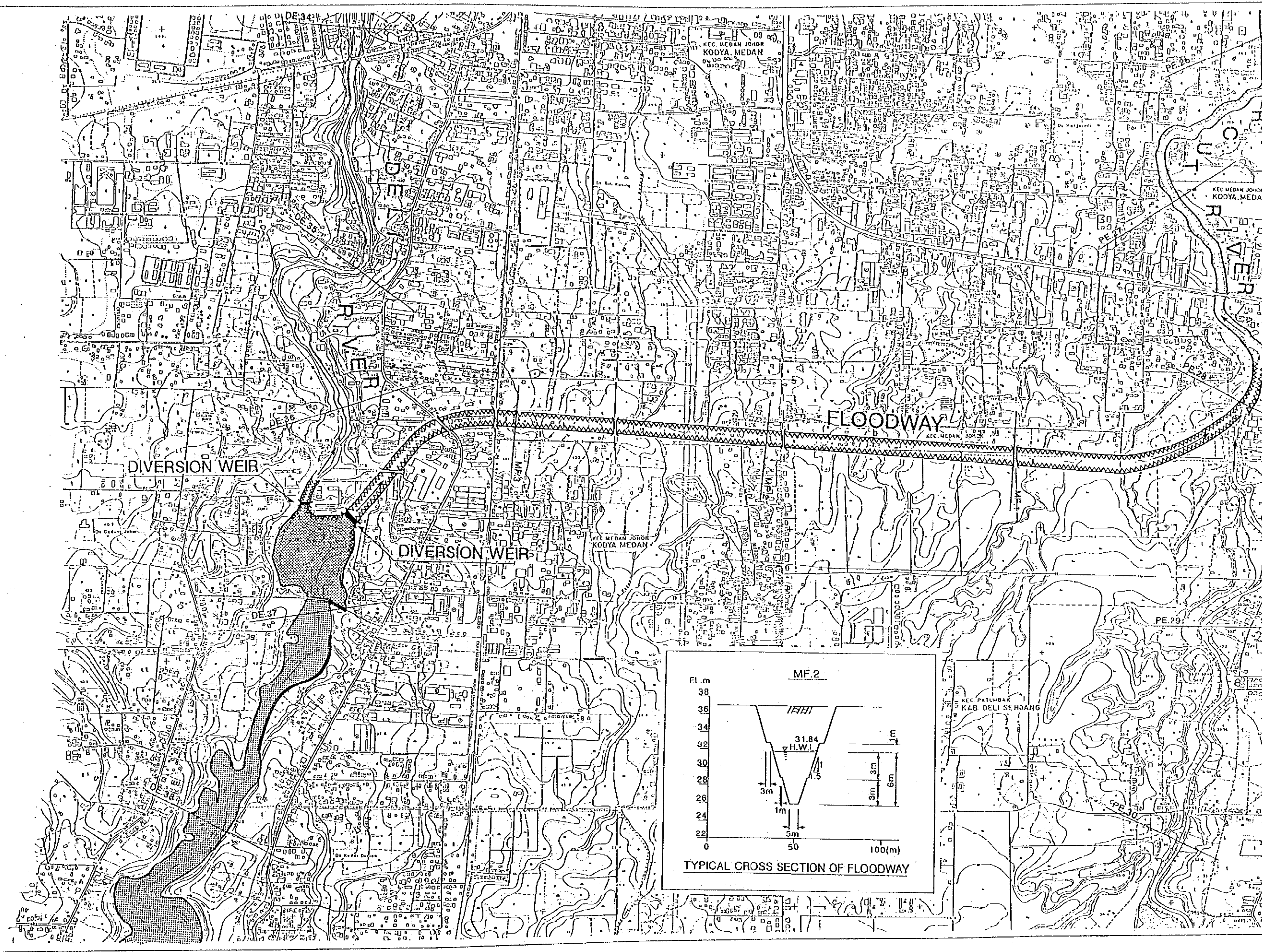
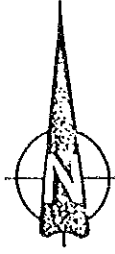

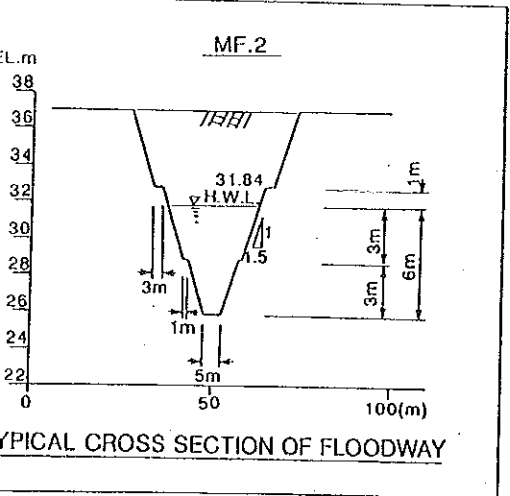
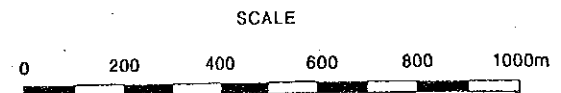
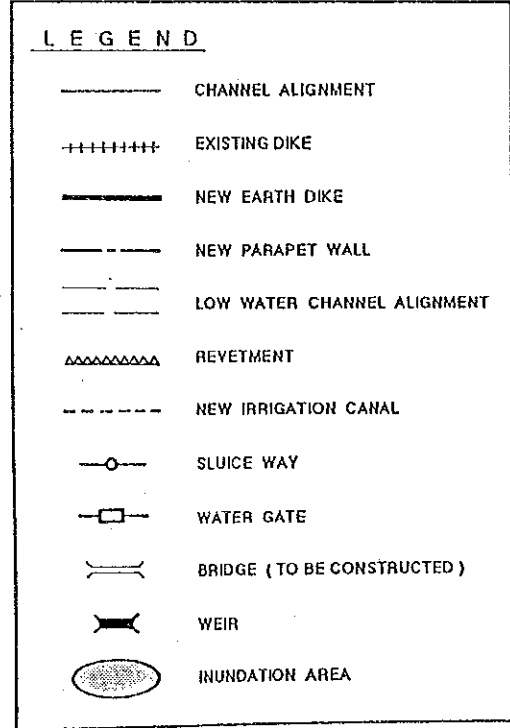
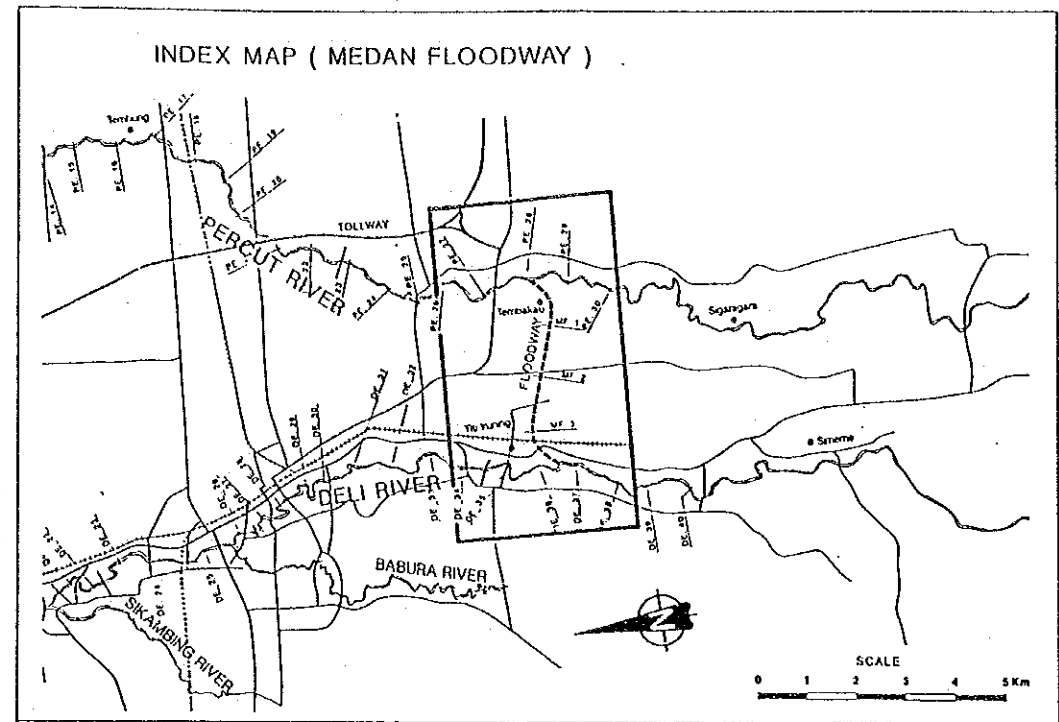
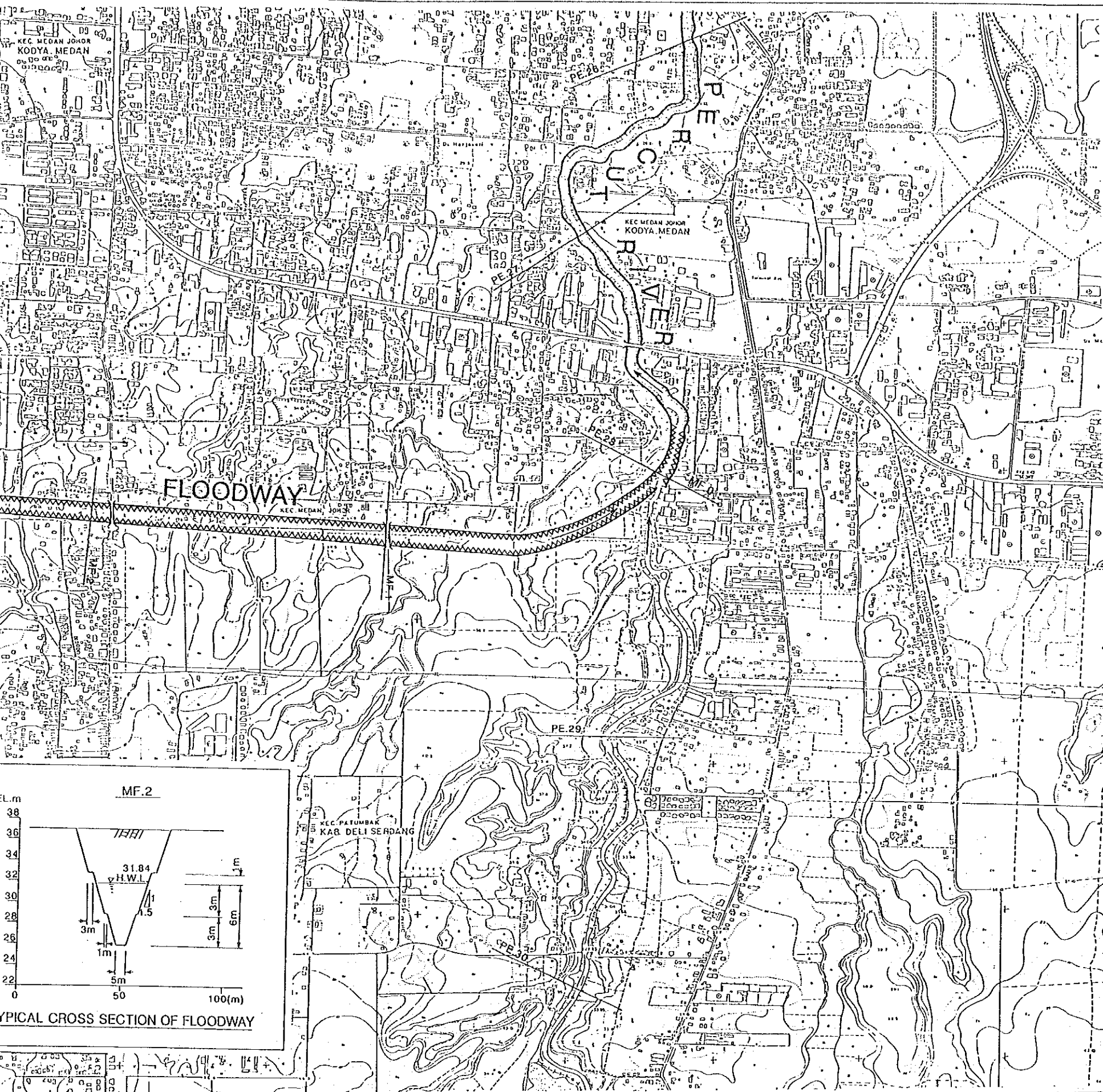

THE STUDY ON BELAWAN BASIN INTEGRATED WITH RIVER DEVELOPMENT IN THE RETURN OF BANARASA
 JAWABER TRADITIONAL COOPERATION AGENCY

ALIGNMENT AND TYPICAL CROSS SECTION OF PROPOSED MEDAN FLOODWAY Fig. 3-12

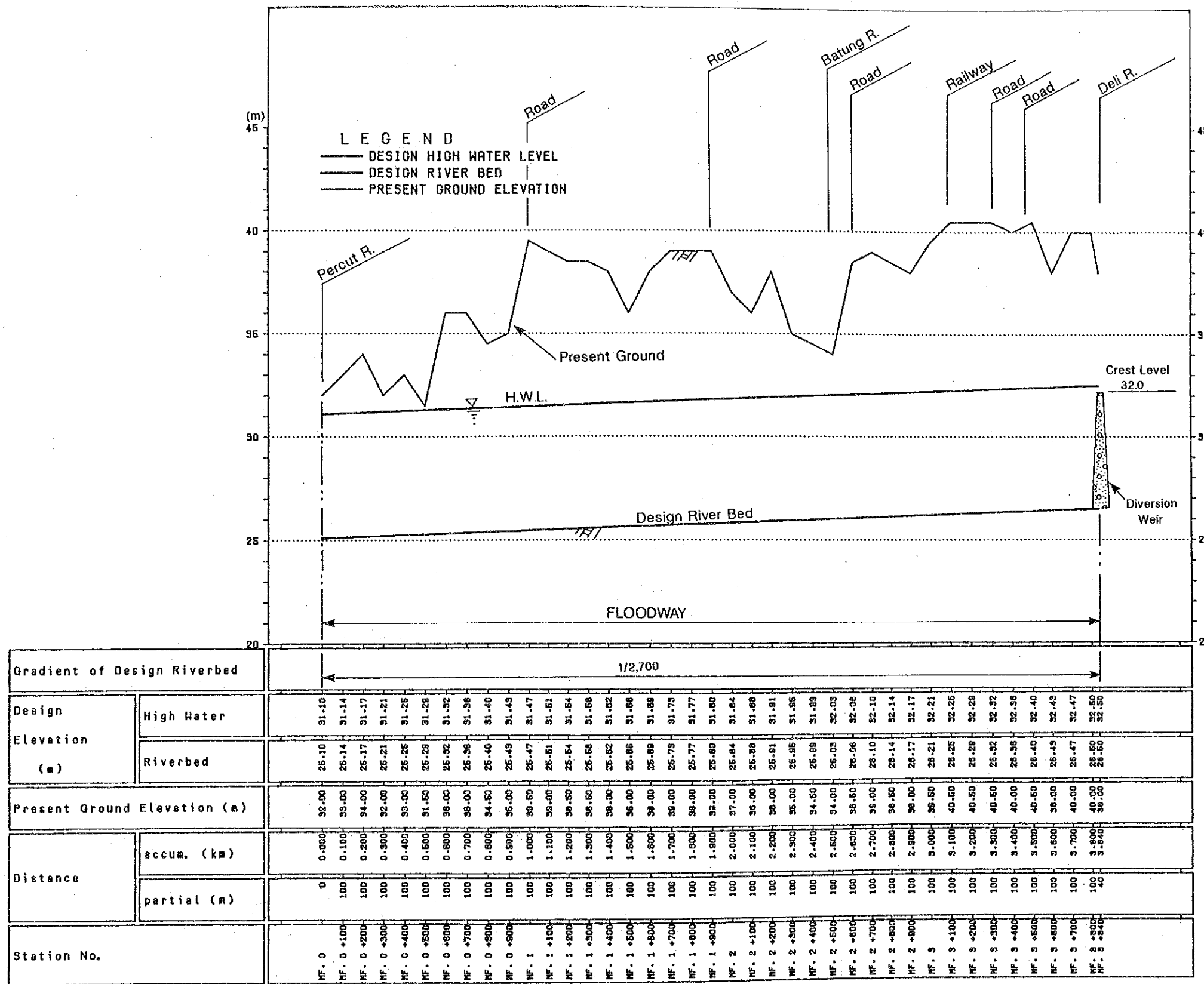

THE STUDY ON BELAWAN-PADANG INTEGRATED RIVER BASIN DEVELOPMENT
IN THE REPUBLIC OF INDONESIA

JAPAN INTERNATIONAL COOPERATION AGENCY

LONGITUDINAL PROFILE OF PROPOSED MEDAN FLOODWAY

Fig.3-13

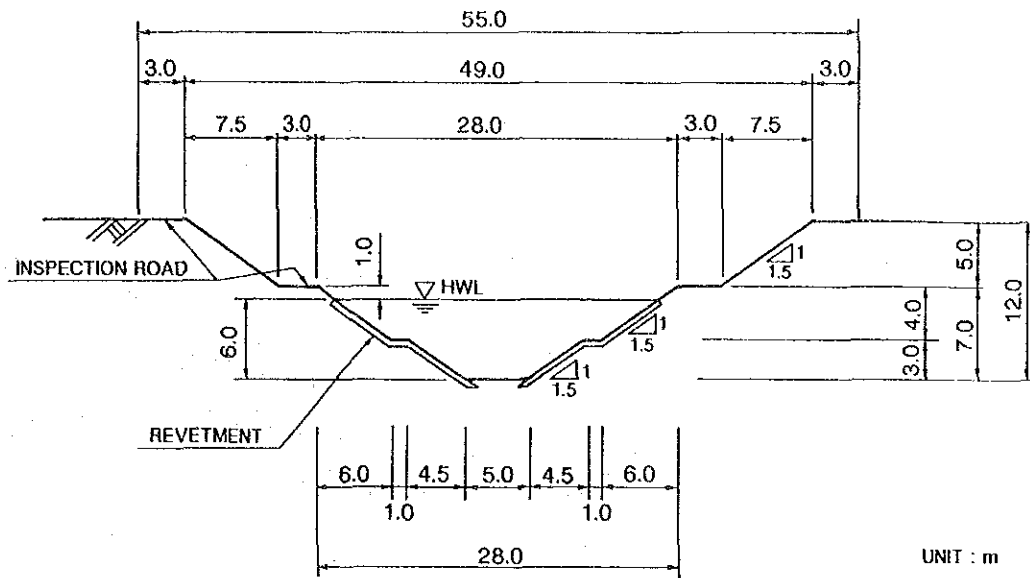

UNIT : m

TYPICAL CROSS SECTION

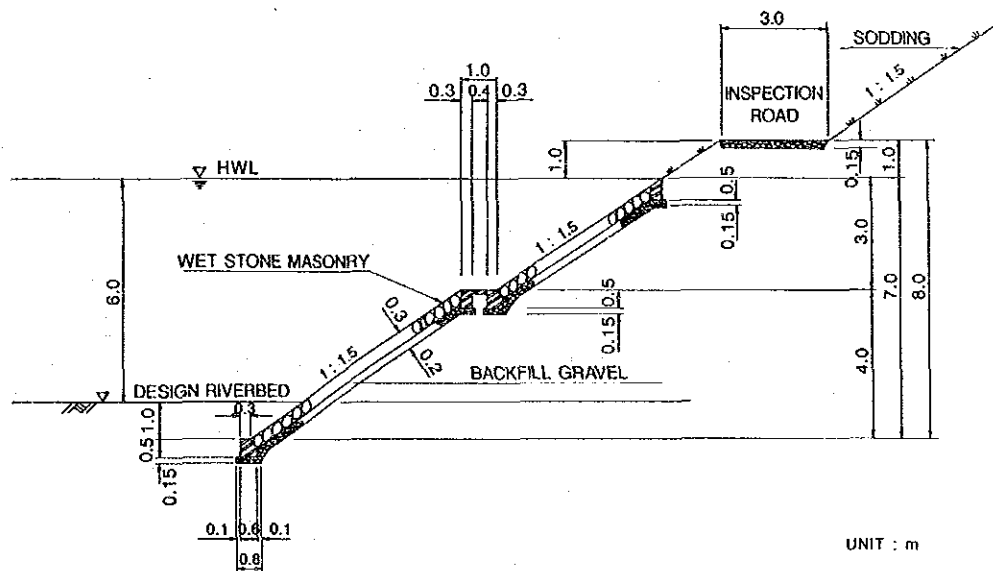

UNIT : m

STRUCTURE OF REVETMENT

THE STUDY ON BELAWAN-PADANG INTEGRATED RIVER BASIN DEVELOPMENT
 IN THE REPUBLIC OF INDONESIA
 JAPAN INTERNATIONAL COOPERATION AGENCY

TYPICAL CROSS SECTION AND STRUCTURE
 OF REVETMENT FOR MEDAN FLOODWAY
 Fig. 3-14

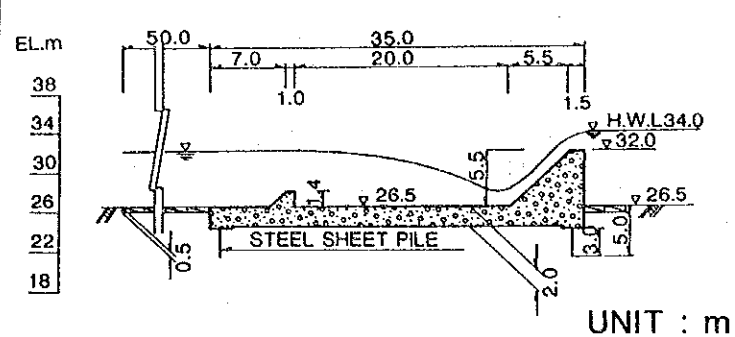

SECTION A-A

UNIT : m

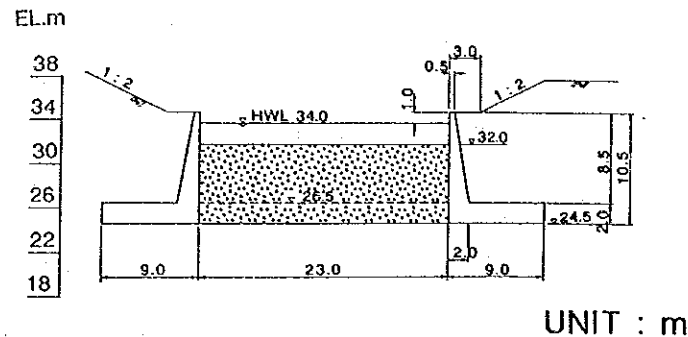

SECTION B-B

UNIT : m

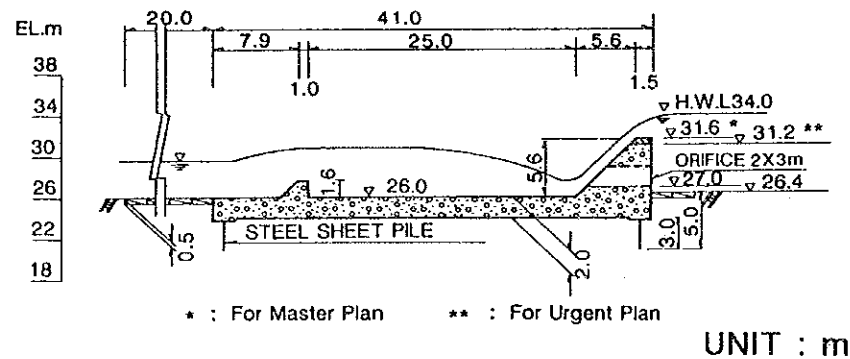

SECTION C-C

UNIT : m

* : For Master Plan ** : For Urgent Plan

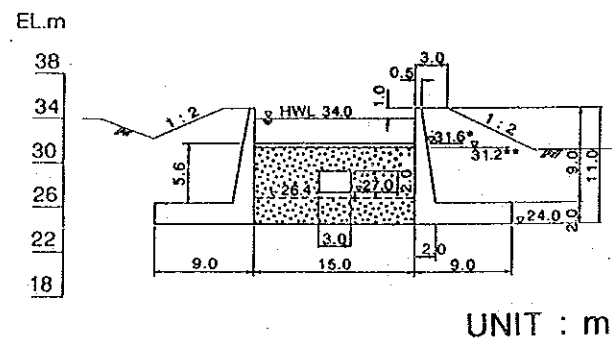

SECTION D-D

UNIT : m

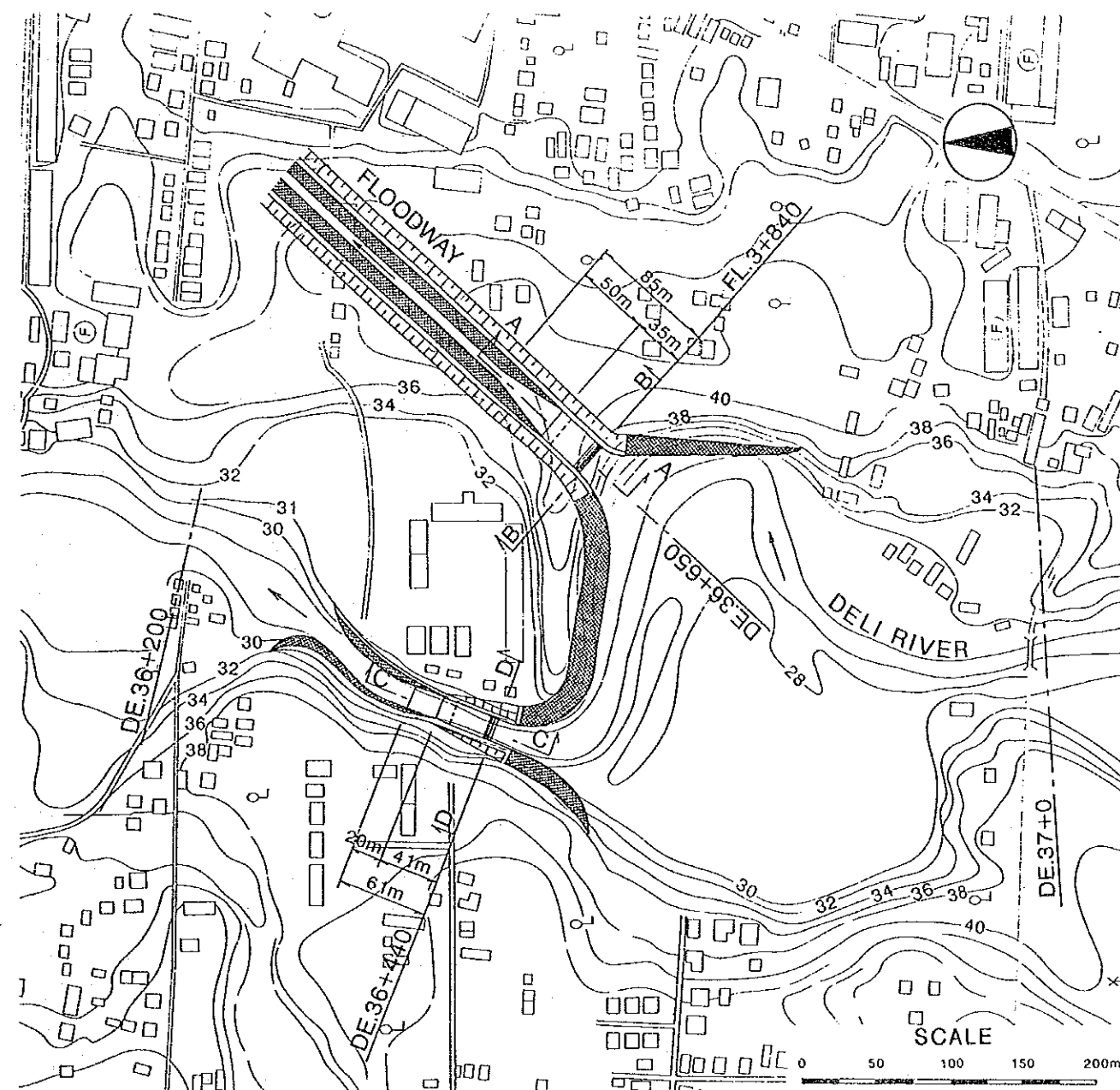

PLAN OF DIVERSION FACILITY

THE STUDY ON BELAWAN-PADANG INTEGRATED RIVER BASIN DEVELOPMENT IN THE REPUBLIC OF INDONESIA	LAYOUT AND STRUCTURE OF PROPOSED DIVERSION WORKS
JAPAN INTERNATIONAL COOPERATION AGENCY	Fig.3-15

1. FOR URGENT PLAN

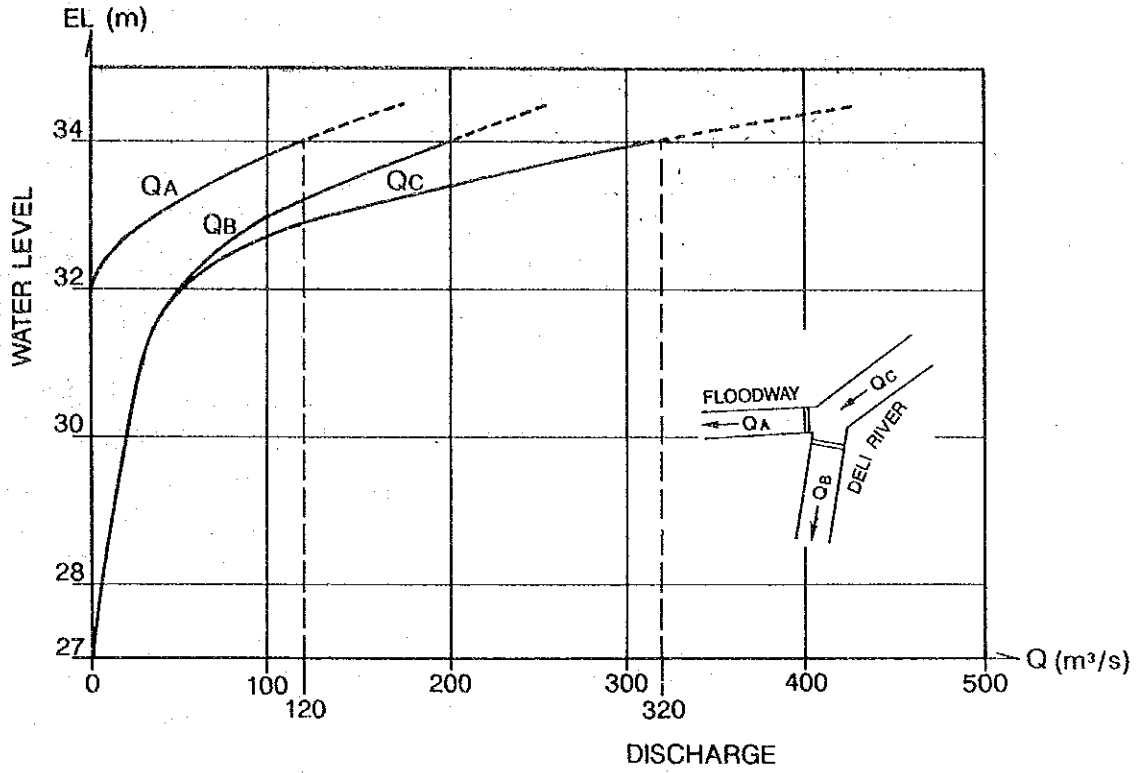

2. FOR MASTER PLAN

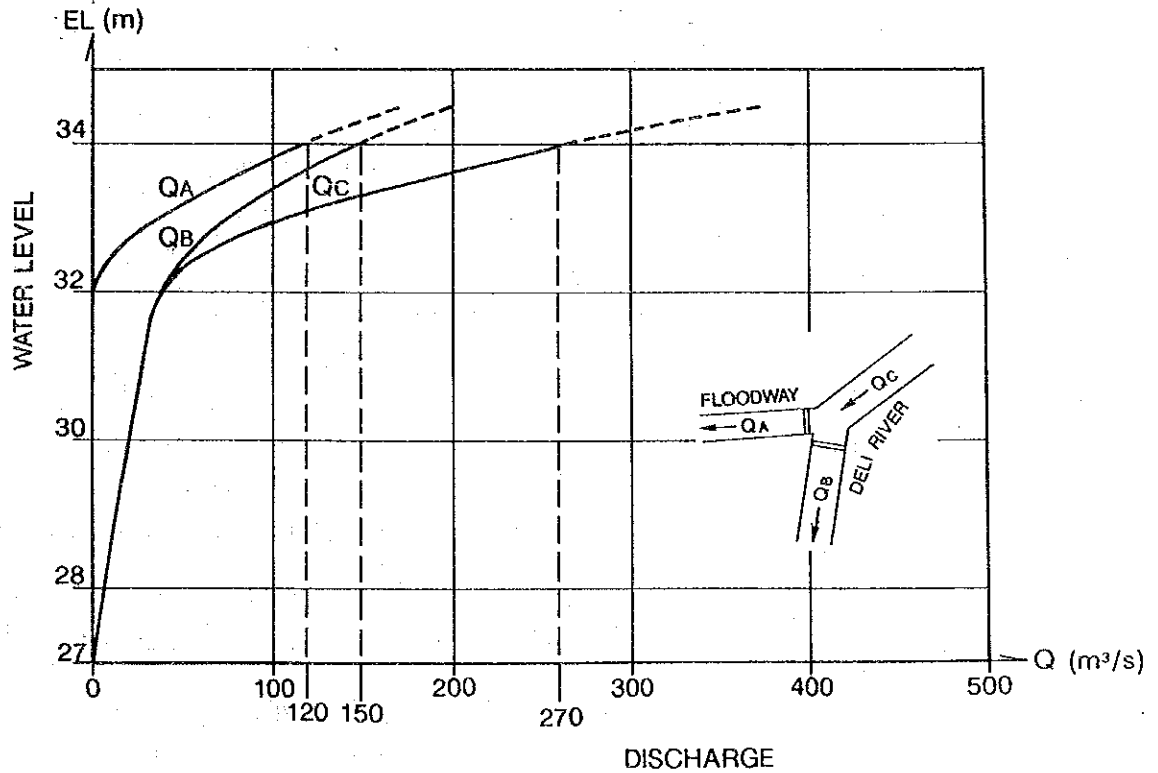

THE STUDY ON BELAWAN-PADANG INTEGRATED RIVER BASIN DEVELOPMENT
IN THE REPUBLIC OF INDONESIA

JAPAN INTERNATIONAL COOPERATION AGENCY

RATING CURVES OF PROPOSED DIVERSION FACILITIES

Fig.3-16

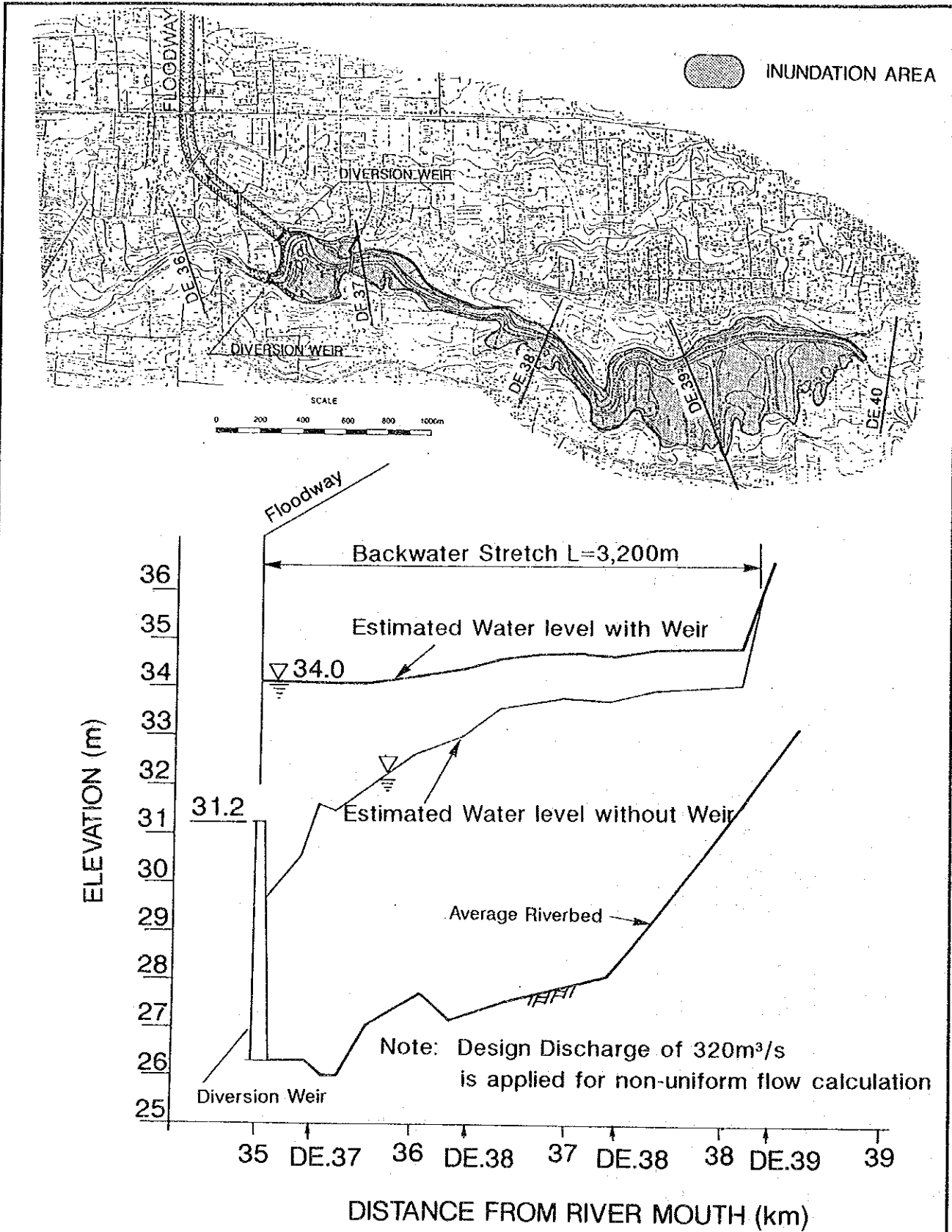

TYPE - A

LOCATION	L	B
DE. 27+500	32.0	5.0
DE. 29+70	32.0	5.0
Sikambang R. Buntu Br.	19.0	7.2
Sikambang R. Utama Br.	17.0	5.0
PE. 14+24	38.0	4.0
PE. 14+28	42.0	2.5
PE. 15+31	41.0	1.4
PE. 17+238	47.0	9.5
PE. 17+980	51.0	5.0
PE. 20+346	42.0	8.7
PE. 22+500	47.0	11.4
PE. 22+794	40.0	1.5
PE. 24+971	47.0	9.7
PE. 27+435	50.0	8.4
Bahiliang R. Br.	20.0	5.0

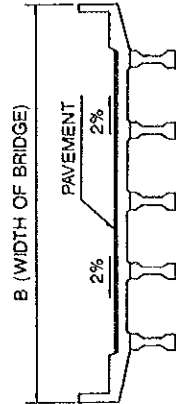

SECTION A-A

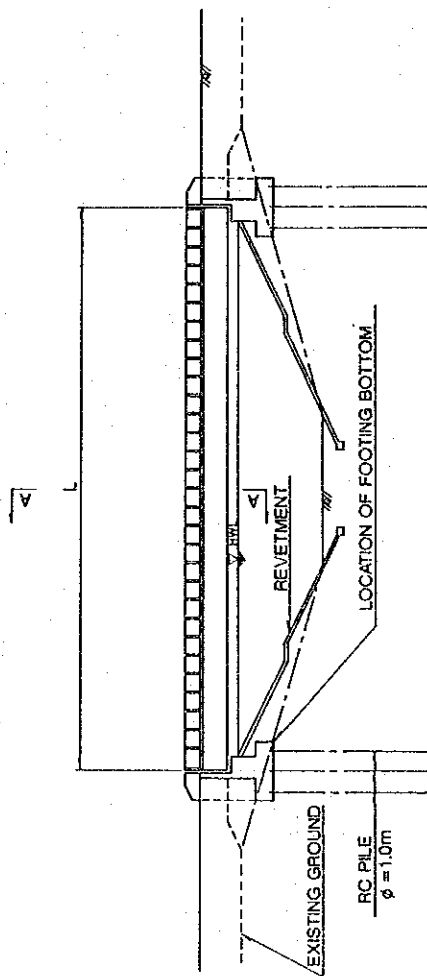

PROFILE

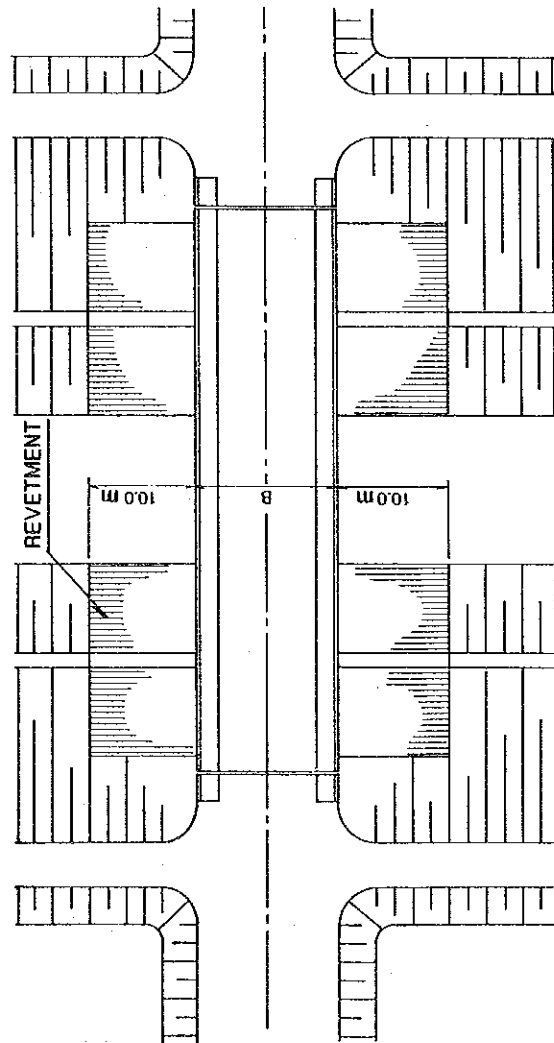

PLAN

THE STUDY ON BELAWAN-PADANG INTEGRATED RIVER BASIN DEVELOPMENT
IN THE REPUBLIC OF INDONESIA

JAPAN INTERNATIONAL COOPERATION AGENCY

STANDARD DESIGN OF BRIDGE
(TYPE - A)

Fig. 3-18(1/3)

TYPE - B					TYPE - C					TYPE - D					TYPE - E					TYPE - F				TYPE - G															
D : More Than 5.0m					D : More Than 5.0m					D : More Than 5.0m					D : More Than 5.0m					D : More Than 5.0m				D : More Than 5.0m															
LOCATION	L ₀	L ₁	L ₂	B	LOCATION	L ₀	L ₁	L ₂	L ₃	B	LOCATION	L ₀	L ₁	L ₂	L ₃	B	LOCATION	L ₀	L ₁	L ₂	L ₃	B	LOCATION	L ₀	L ₁	L ₂	L ₃	B											
DELI RIVER	DE. 4+375	65	32.5	32.5	1.2	DELI RIVER	DE. 0+350	110	25.0	60.0	25.0	5.0	PERCUT RIVER	PE. 5+995	80	23.0	34.0	23.0	3.1	DELI RIVER	DE. 21+160	70	18.0	26.0	26.0	1.8	PERCUT RIVER	PE. 11+774	55	15.0	40.0	1.8	PADANG RIVER	PA. 4+172	260	25.0	30.0	25.0	4.8
	DE. 5+165	63	31.5	31.5	9.7		DE. 0+900	67	22.0	23.0	22.0	9.3		PE. 8+708	105	35.0	45.0	25.0	3.8		DE. 9+200	59	29.5	29.5	5.0	PA. 24+78		82	27.0	28.0	27.0	9.5							
	DE. 7+250	61	30.5	30.5	5.0		DE. 2+670	67	22.0	23.0	22.0	1.9		PA. 24+966	82	27.0	28.0	27.0	5.0		DE. 11+300	57	28.5	28.5	4.0	PA. 26+85		82	27.0	28.0	27.0	11.7							
	DE. 13+365	48	24.0	24.0	1.6	DE. 13+1200	47	23.5	23.5	5.0	DE. 16+300	47	23.5	23.5	5.0	DE. 20+205	47	23.5	23.5	9.7	DE. 23+815	50	25.0	25.0	11.0	DE. 25+335	56	28.0	28.0	17.0									

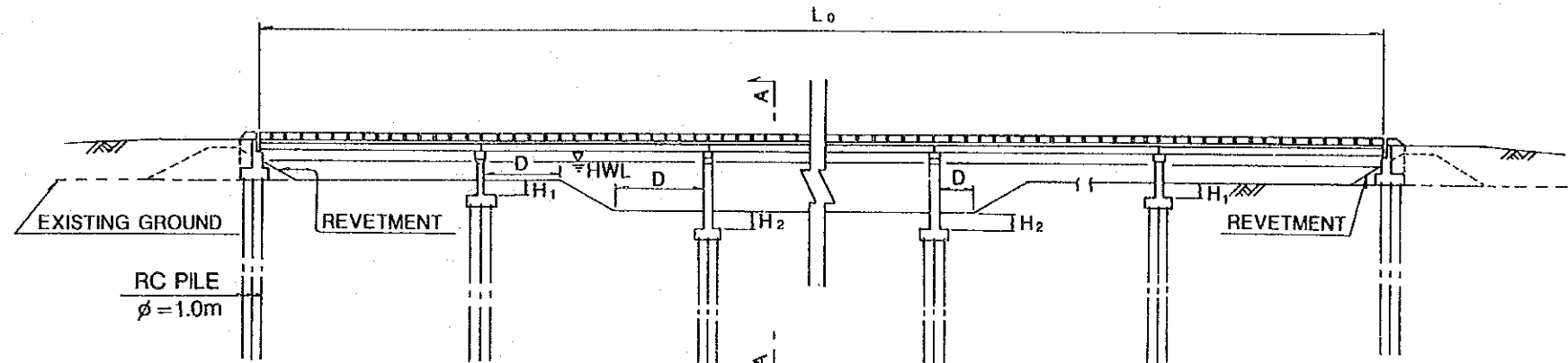

PROFILE

NOTE
H₁: More Than 1.0m
H₂: More Than 2.0m
D : More Than 5.0m

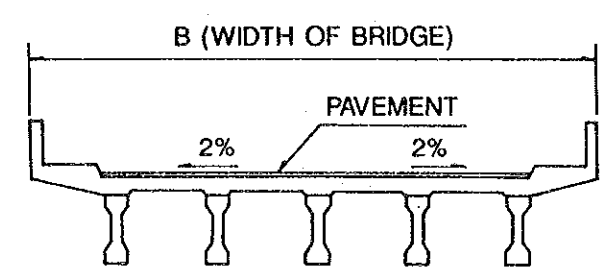

SECTION A-A

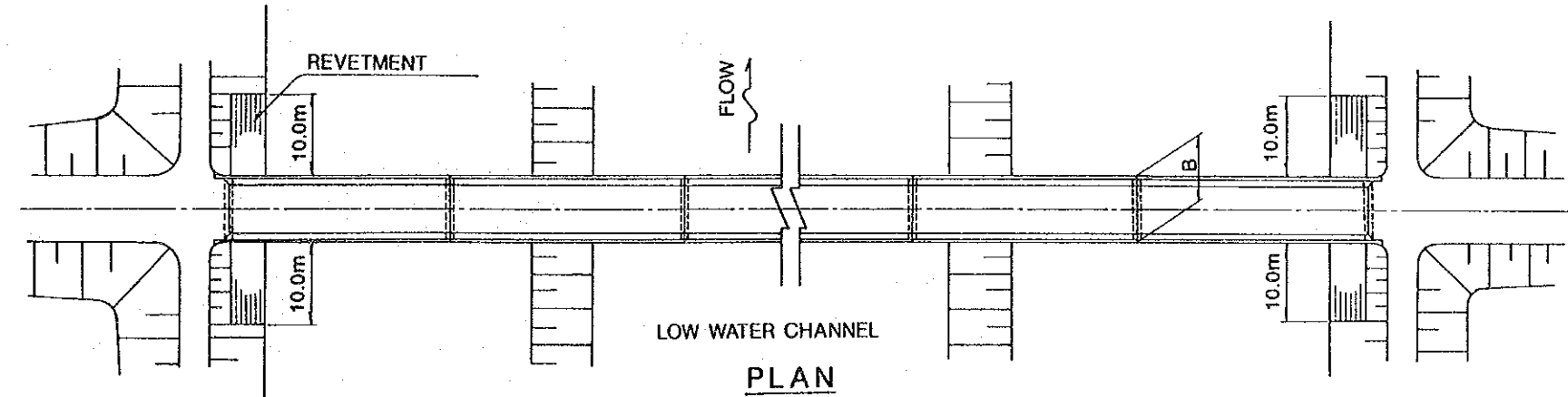

PLAN

TYPE - H

LOCATION	L ₀	L ₁	L ₂	B
MF. 0+990	55	12.0	31.0	6.0
MF. 1+930	53	11.5	30.0	6.0
MF. 2+600	50	11.0	28.0	6.0
MF. 3+80	56	12.0	32.0	5.0
MF. 3+300	70	15.0	40.0	8.0
MF. 3+600	75	16.0	43.0	6.0
27+435	50	11.0	28.0	8.5
DE. 36+950	100	21.5	57.0	1.2

MEDAN FLOODWAY

DELI RIVER

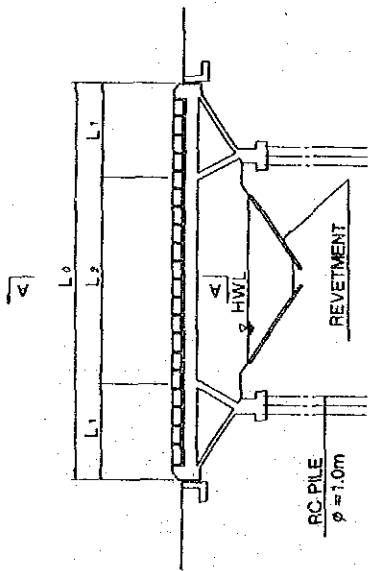

PROFILE

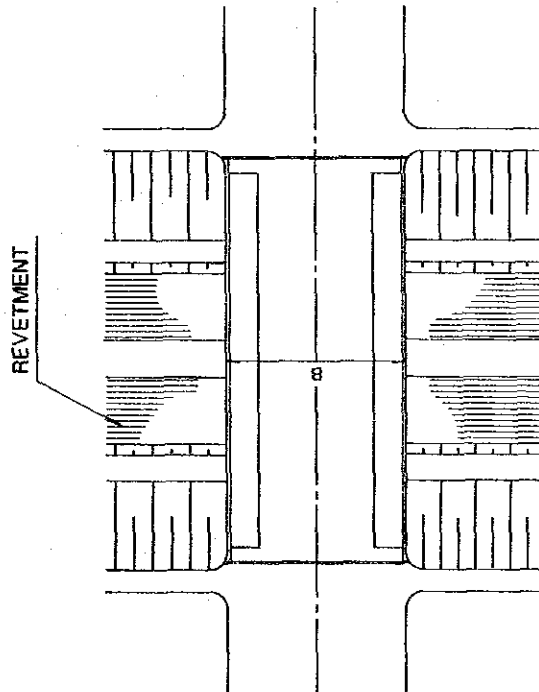

PLAN

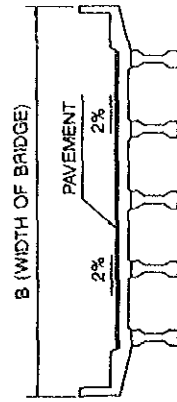

SECTION A-A

THE STUDY ON BELAWAN-PADANG INTEGRATED RIVER BASIN DEVELOPMENT
IN THE REPUBLIC OF INDONESIA

JAPAN INTERNATIONAL COOPERATION AGENCY

STANDARD DESIGN OF BRIDGE
(TYPE - H)

Fig.3-18(3/3)

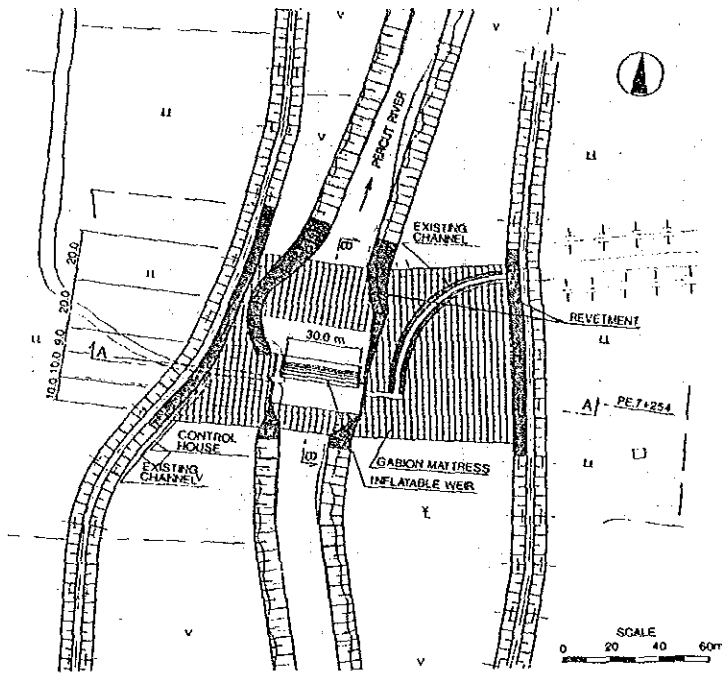

PLAN OF INTAKE WEIR (INFLATABLE WEIR)

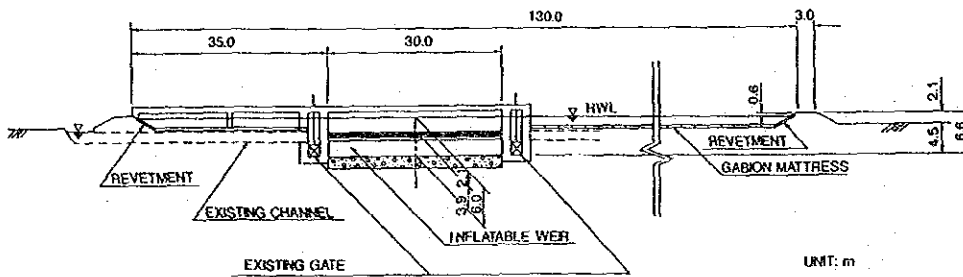

SECTION A-A

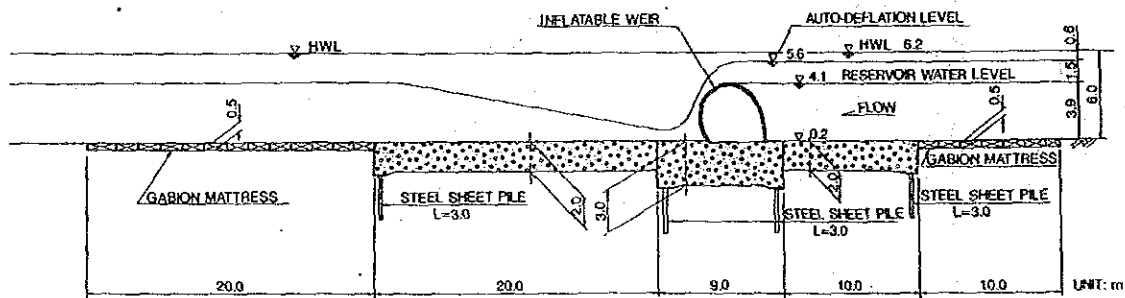

SECTION B-B

THE STUDY ON BELAWAN-PADANG INTEGRATED RIVER BASIN DEVELOPMENT
IN THE REPUBLIC OF INDONESIA

JAPAN INTERNATIONAL COOPERATION AGENCY

LAYOUT AND STRUCTURE OF NEW BANDAR
SIDORAS INTAKE WEIR

Fig.3-19

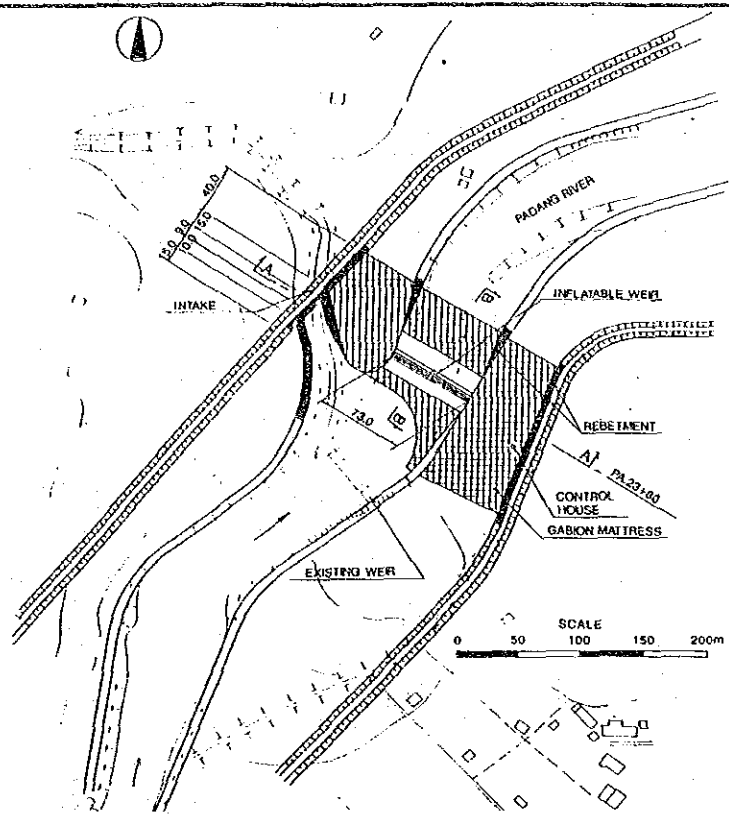

PLAN OF INTAKE WEIR (INFLATABLE WEIR)

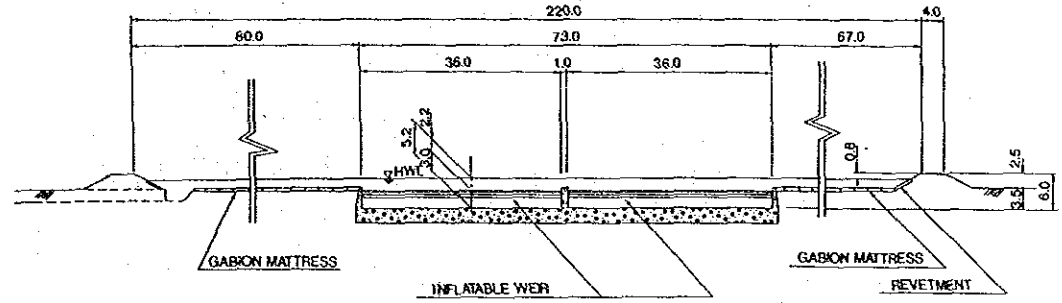

SECTION A-A

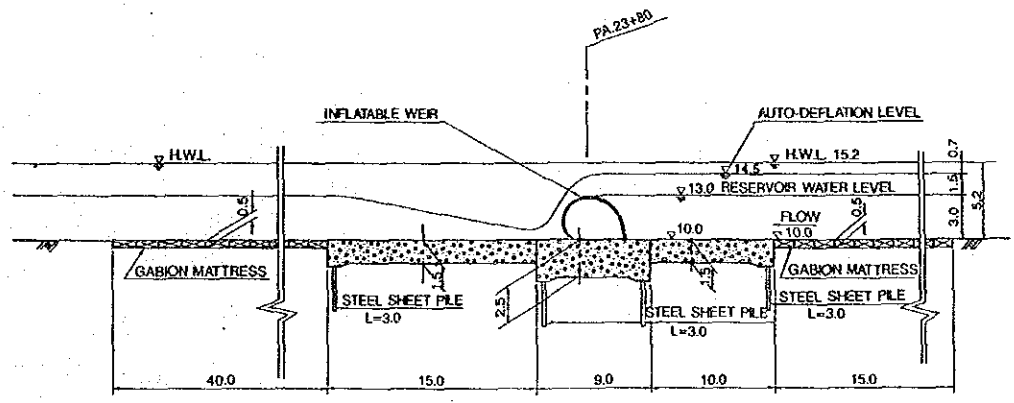

SECTION B-B

THE STUDY ON BELAWAN-PADANG INTEGRATED RIVER BASIN DEVELOPMENT
 IN THE REPUBLIC OF INDONESIA
 JAPAN INTERNATIONAL COOPERATION AGENCY

LAYOUT AND STRUCTURE OF NEW PAYA
 LOMBANG INTAKE WEIR

Fig.3-20

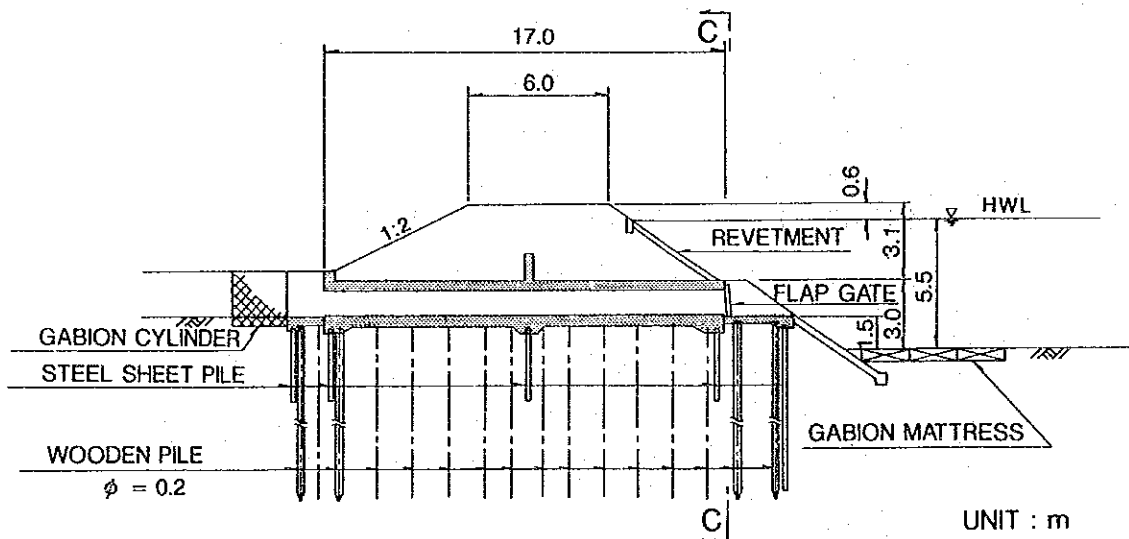
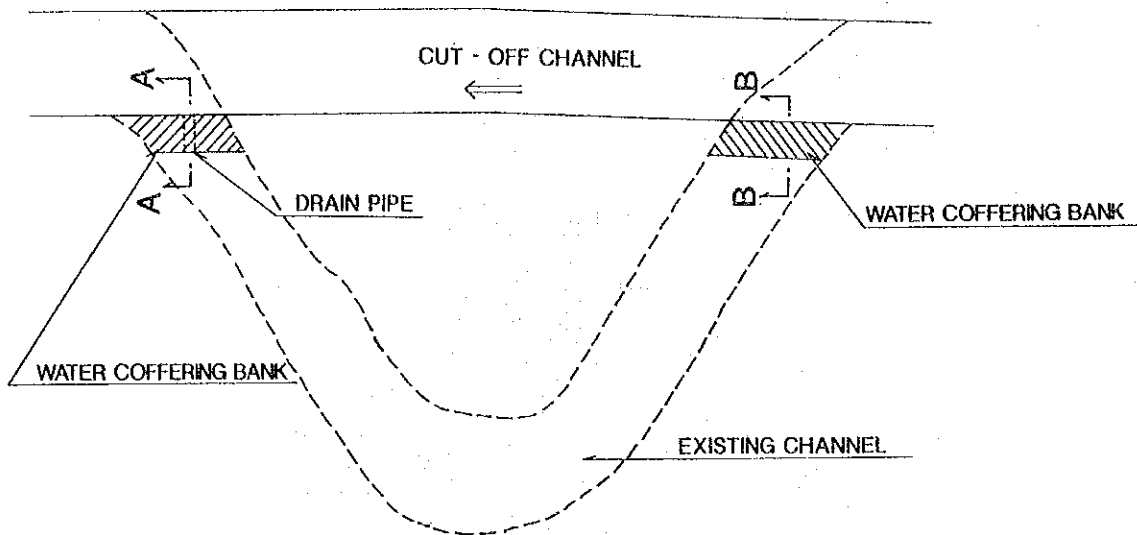

SECTION A - A

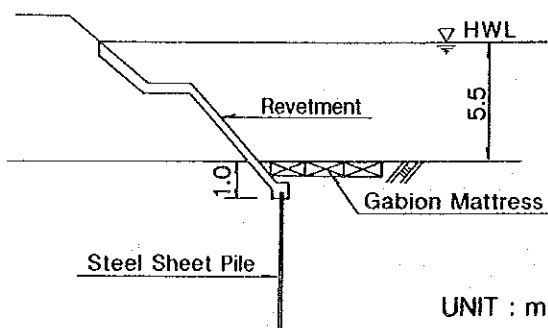

SECTION B - B

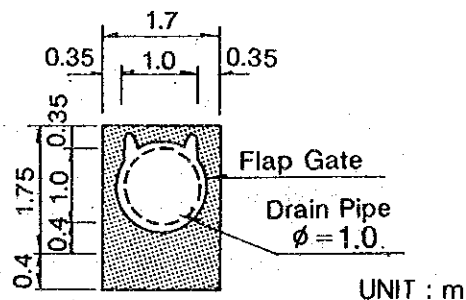

SECTION C - C

	LOCATION		
DELI RIVER	DE. 12+690	DE. 27+380	DE. 29+50

THE STUDY ON BELAWAN-PADANG INTEGRATED RIVER BASIN DEVELOPMENT
IN THE REPUBLIC OF INDONESIA

JAPAN INTERNATIONAL COOPERATION AGENCY

STANDARD DESIGN OF SLUICWAY
(TYPE A-1)

Fig.3-21(1/6)

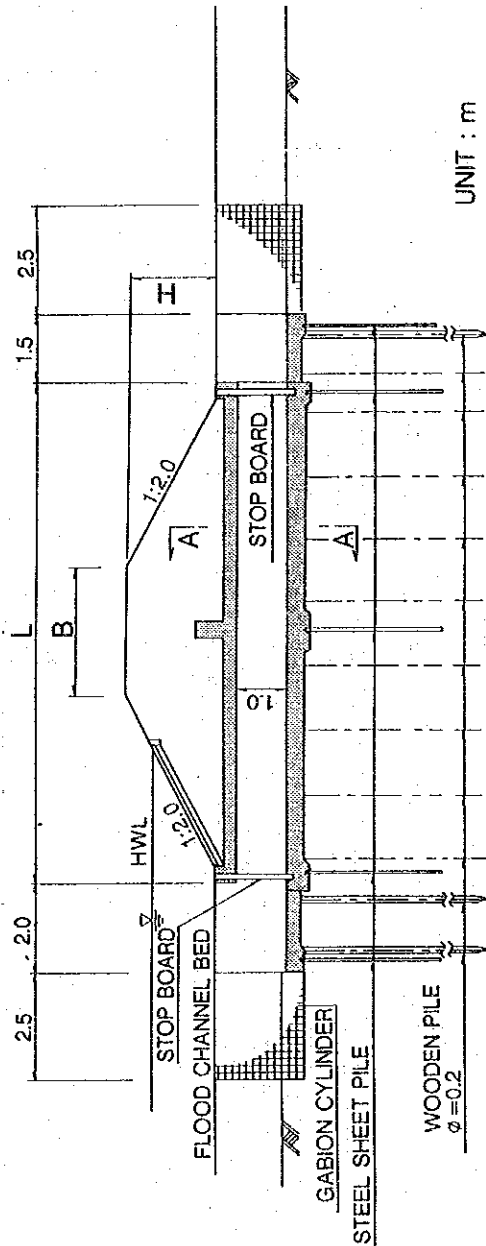

PROFILE

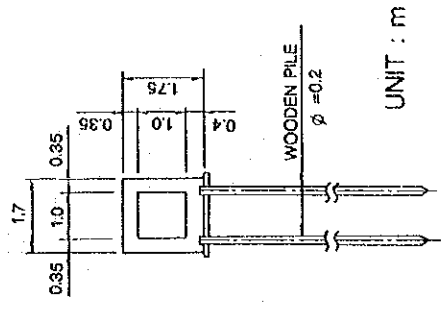

SECTION A - A

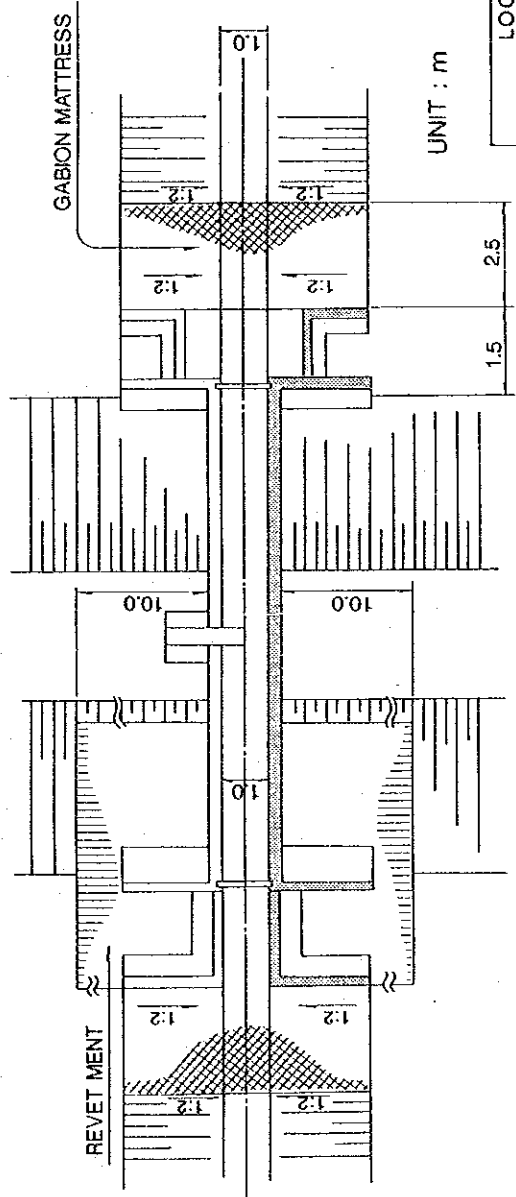

PLAN

LOCATION	B	H	L
PERCUT RIVER PE. 0+600	3	2	11.5
PADANG RIVER PA. 0+450	4	3	16.5

THE STUDY ON BELAWAN-PADANG INTEGRATED RIVER BASIN DEVELOPMENT
IN THE REPUBLIC OF INDONESIA

JAPAN INTERNATIONAL COOPERATION AGENCY

STANDARD DESIGN OF SLUICeway
(TYPE A-2)

Fig.3-21(2/6)

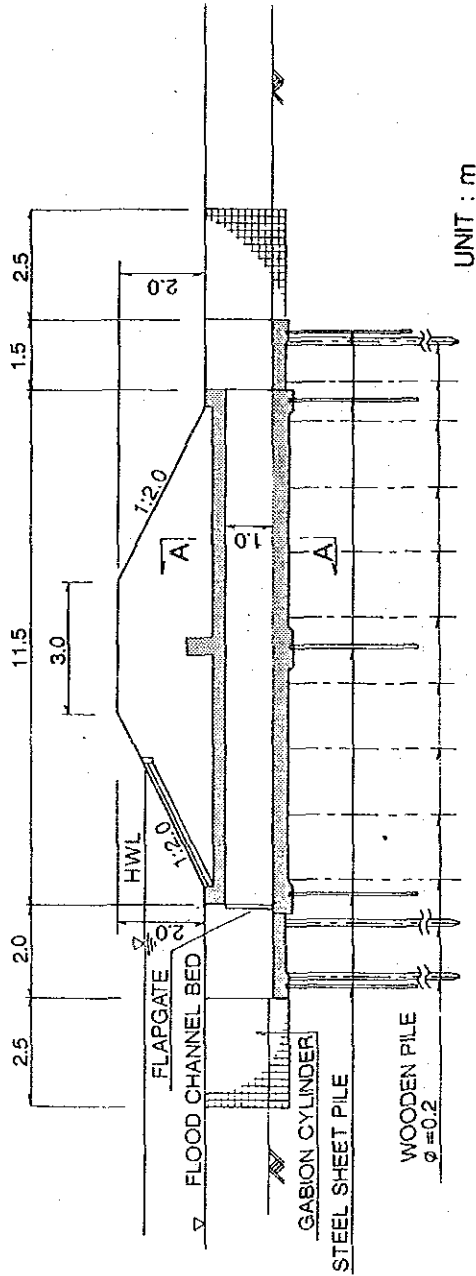

PROFILE

UNIT : m

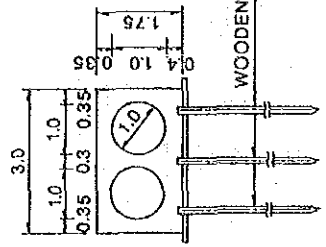

WOODEN PILE ϕ 0.2

UNIT : m

SECTION A - A

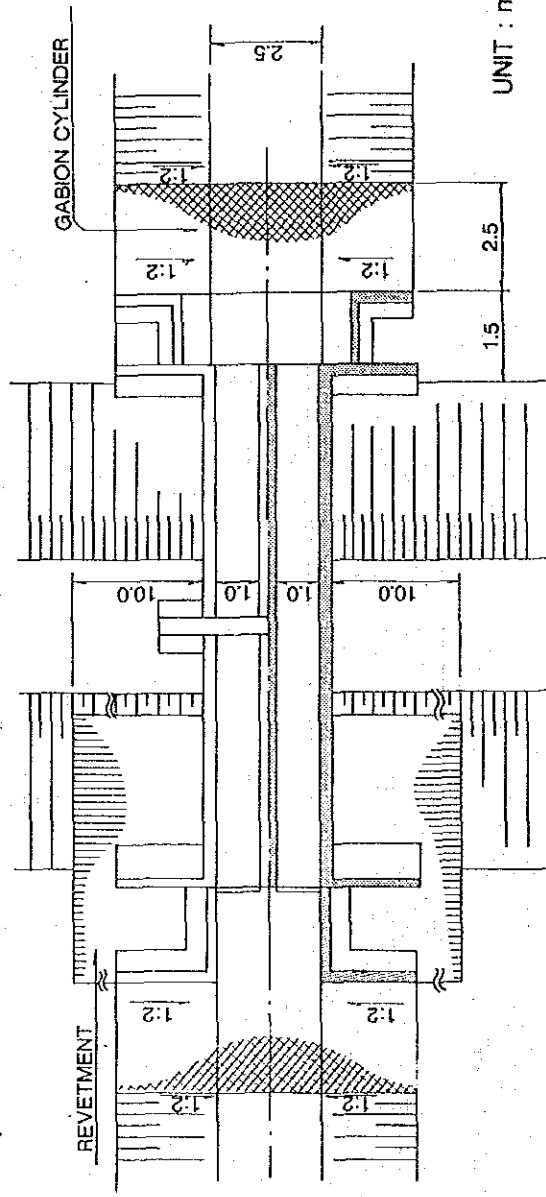

PLAN

UNIT : m

PERCUT RIVER	PE. 8+800	LOCATION	PE. 9+860
--------------	-----------	----------	-----------

THE STUDY ON BELAWAN-PADANG INTEGRATED RIVER BASIN DEVELOPMENT
IN THE REPUBLIC OF INDONESIA
JAPAN INTERNATIONAL COOPERATION AGENCY

STANDARD DESIGN OF SLUICWAY
(TYPE A-3)

Fig.3-21(3/6)

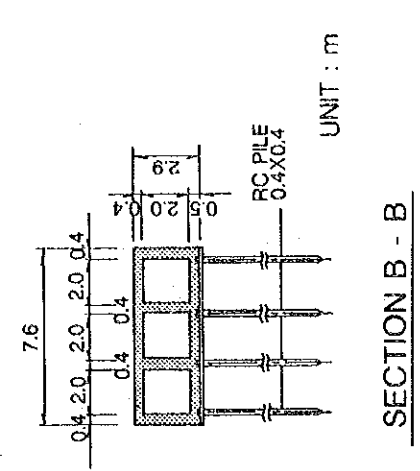
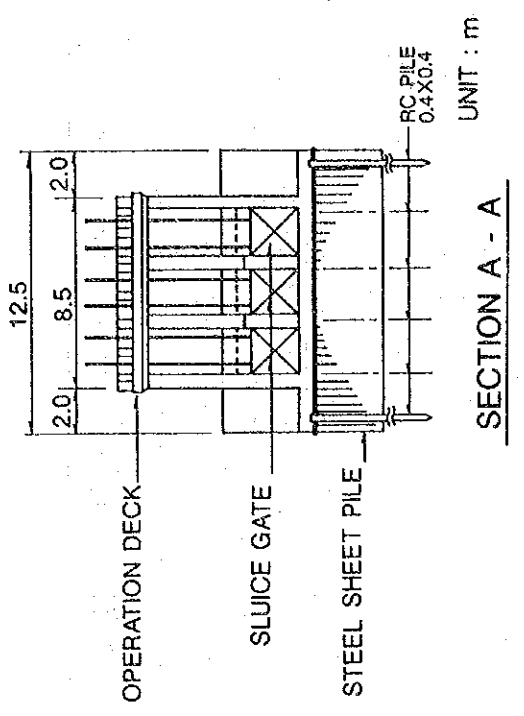
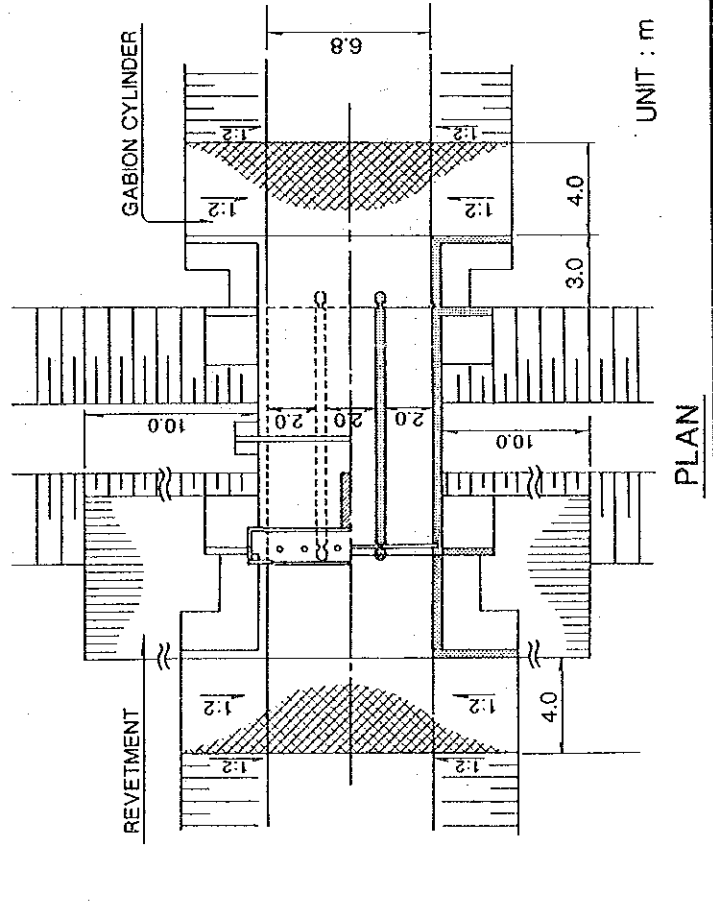
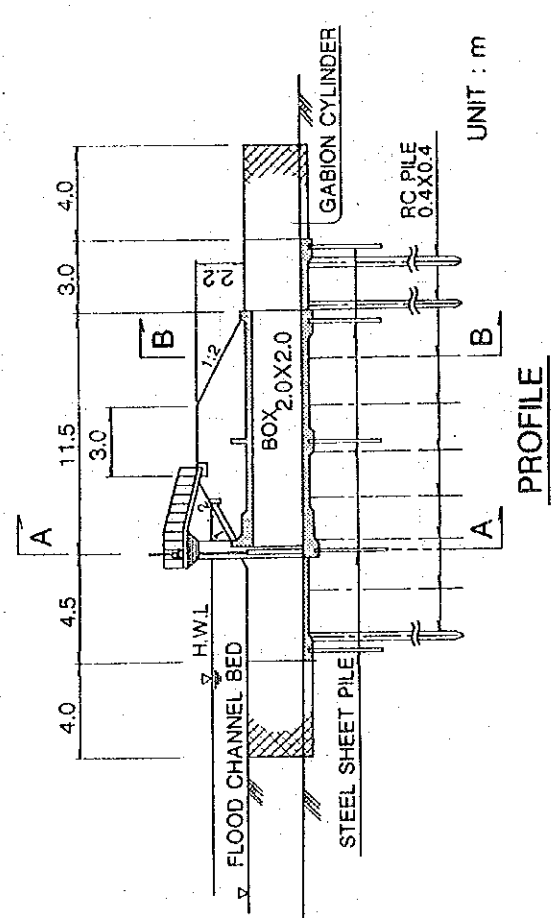

PERCUT RIVER	LOCATION
	PE. 0+850

THE STUDY ON BELAWAN-PADANG INTEGRATED RIVER BASIN DEVELOPMENT
 IN THE REPUBLIC OF INDONESIA
 JAPAN INTERNATIONAL COOPERATION AGENCY

STANDARD DESIGN OF SLUICWAY
 (TYPE B-1)
 Fig.3-21(4/6)

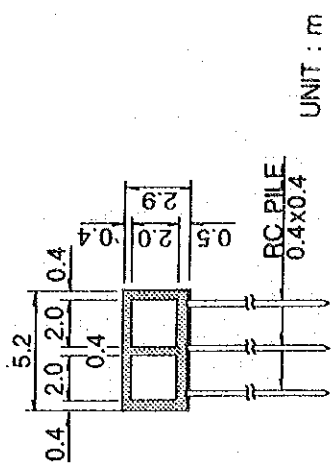
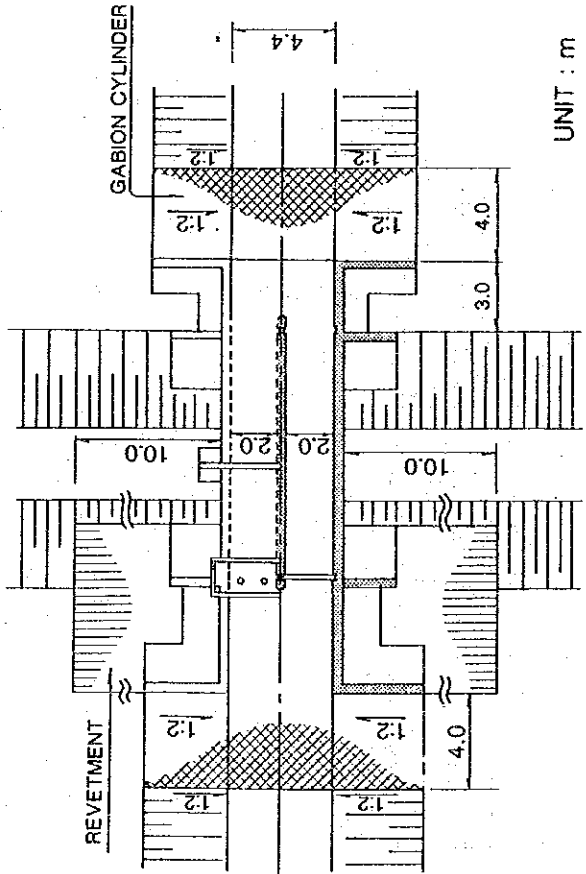
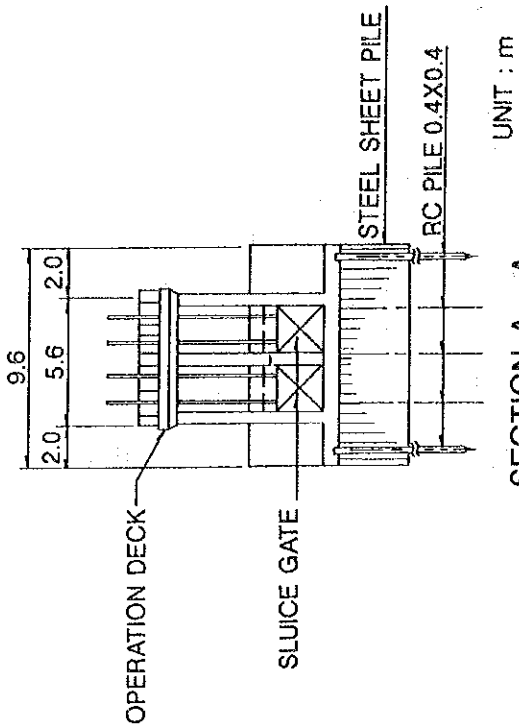
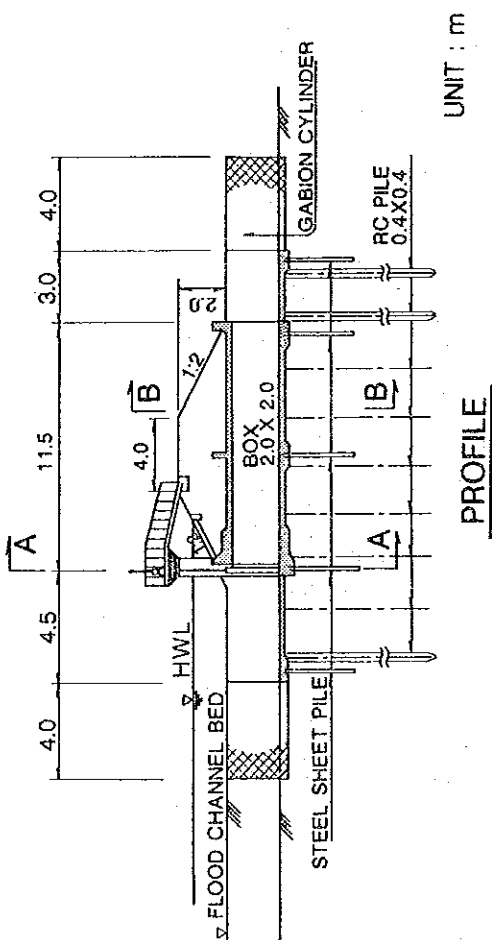

PADANG RIVER	PA. 13+300	LOCATION
	PA. 16+850	PA. 23+100

THE STUDY ON BELAWAN-PADANG INTEGRATED RIVER BASIN DEVELOPMENT
IN THE REPUBLIC OF INDONESIA
JAPAN INTERNATIONAL COOPERATION AGENCY

STANDARD DESIGN OF SLUICWAY
(TYPE B-2)

Fig.3-21(5/6)

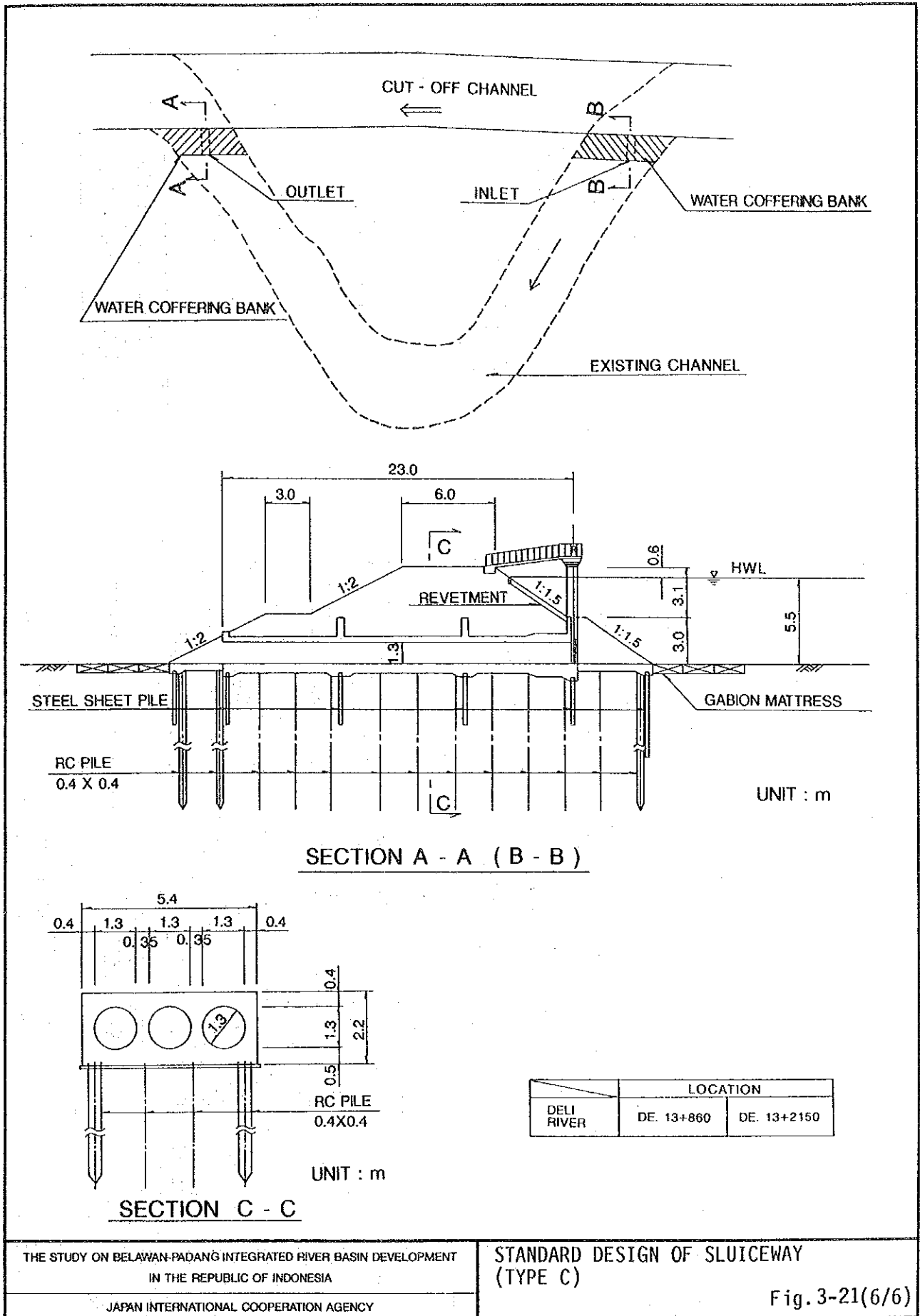

THE STUDY ON BELAWAN-PADANG INTEGRATED RIVER BASIN DEVELOPMENT
IN THE REPUBLIC OF INDONESIA
JAPAN INTERNATIONAL COOPERATION AGENCY

STANDARD DESIGN OF SLUICEWAY
(TYPE C)

Fig. 3-21(6/6)

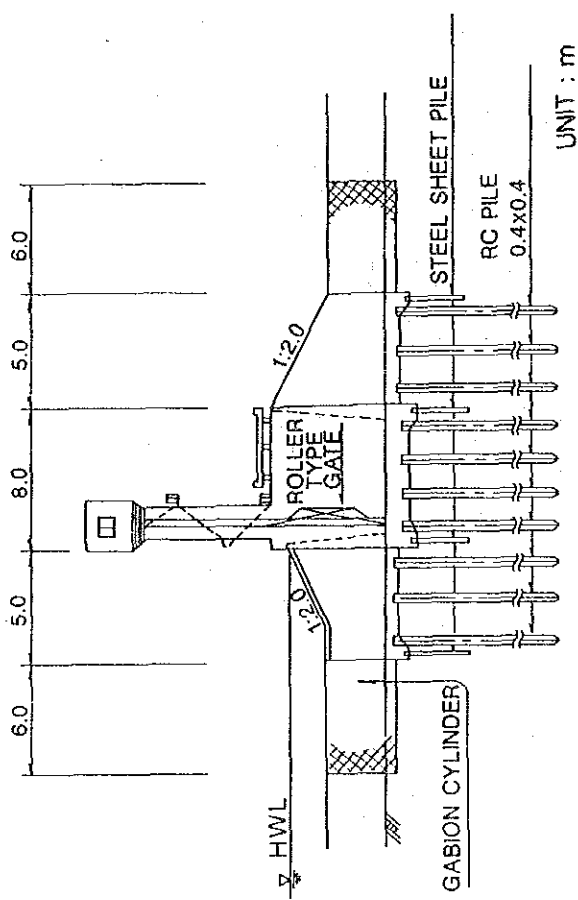

PROFILE

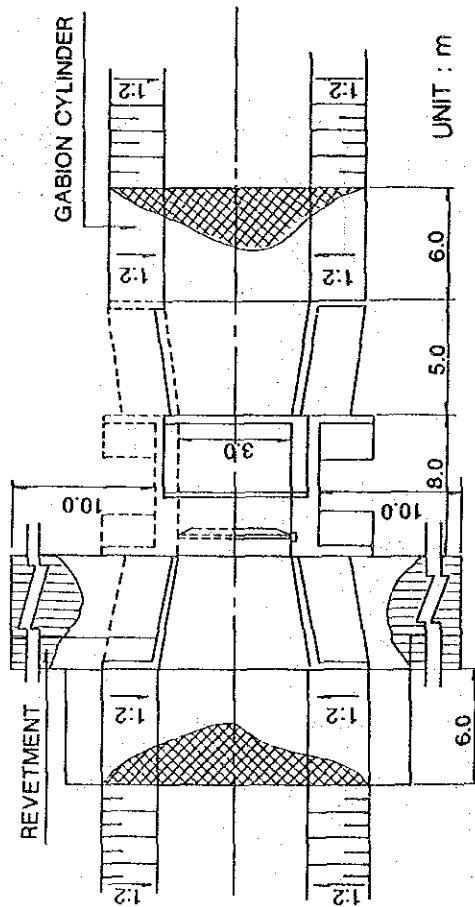

PLAN

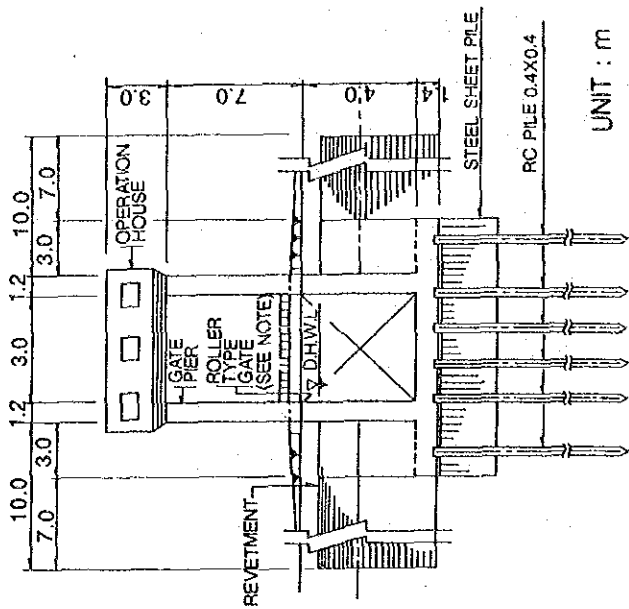

FRONT VIEW

LOCATION	PERCUT RIVER
	PE. 1+350

THE STUDY ON BELAWAN-PADANG INTEGRATED RIVER BASIN DEVELOPMENT
IN THE REPUBLIC OF INDONESIA

JAPAN INTERNATIONAL COOPERATION AGENCY

STANDARD DESIGN OF WATER GATE
(TYPE G)

Fig.3-22

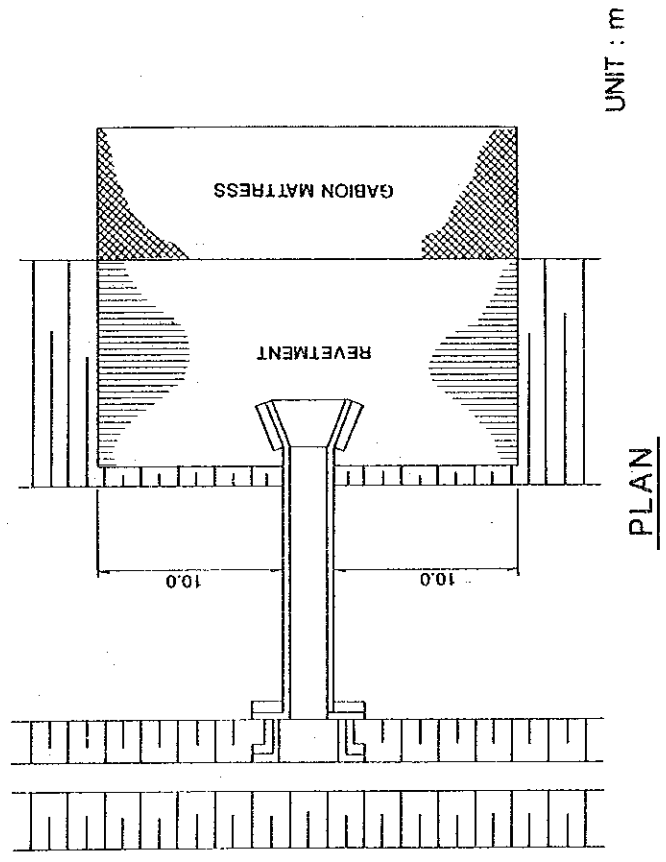
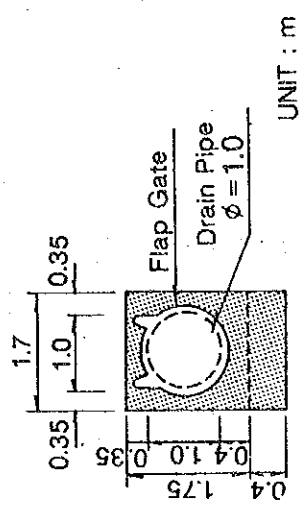
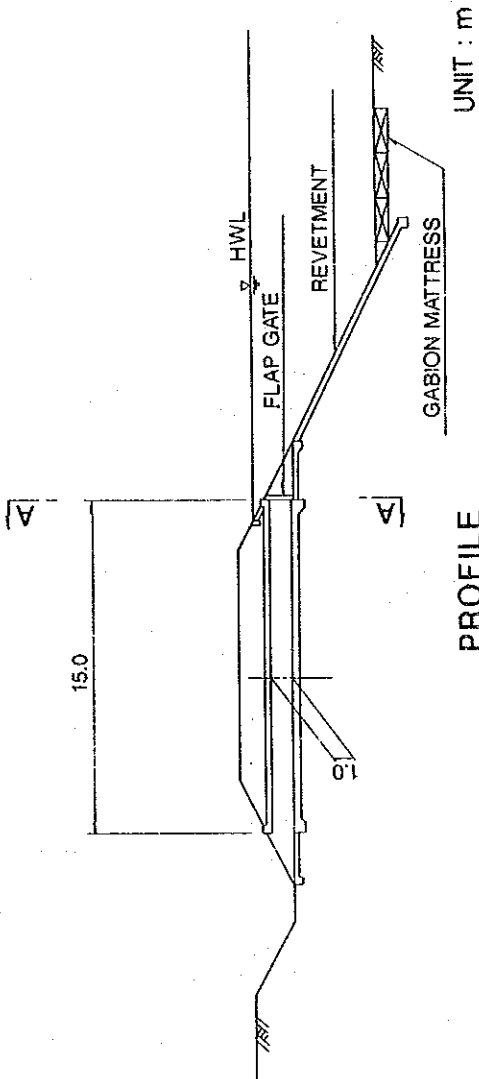

THE STUDY ON BELAWAN-PADANG INTEGRATED RIVER BASIN DEVELOPMENT
IN THE REPUBLIC OF INDONESIA
JAPAN INTERNATIONAL COOPERATION AGENCY

STANDARD DESIGN OF DRAIN PIPE

Fig.3-23

(1) SETTING BACK OF DIKE

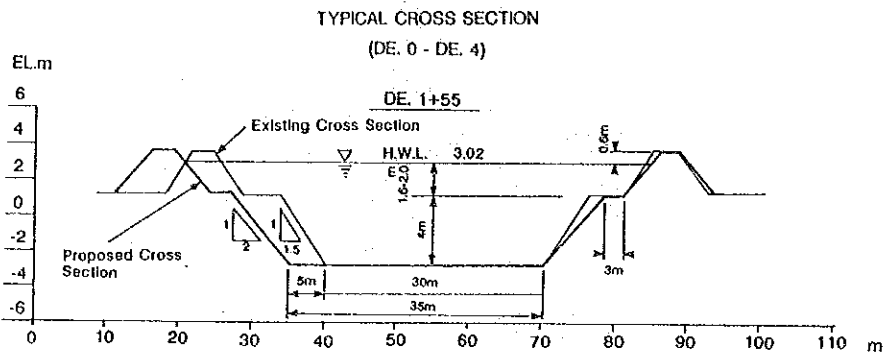

(2) EXISTING CHANNEL WIDTH WITH SHEET PILE

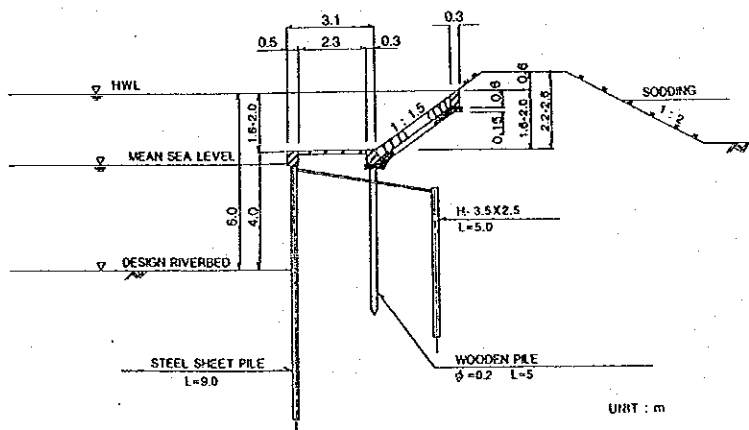
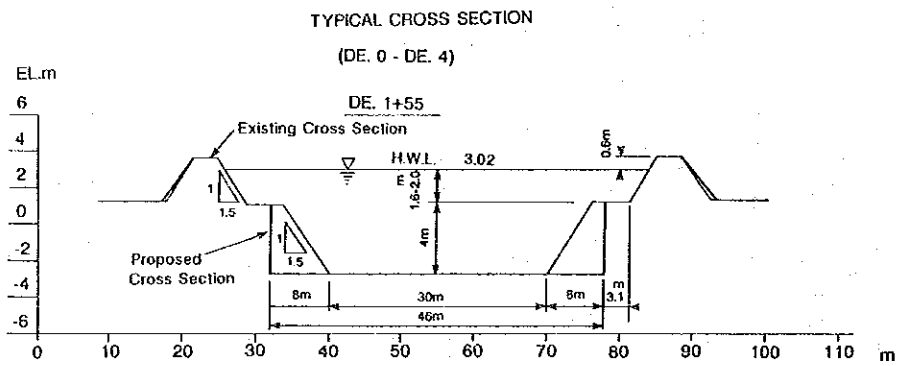

(1) EXISTING CHANNEL

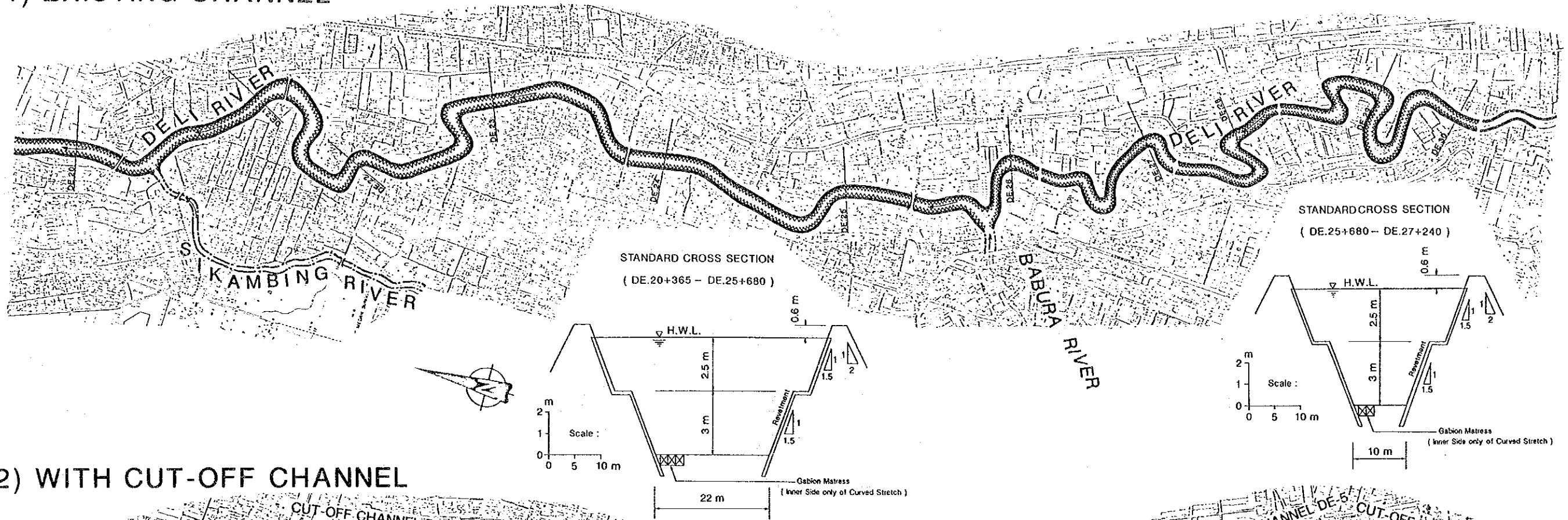

(2) WITH CUT-OFF CHANNEL

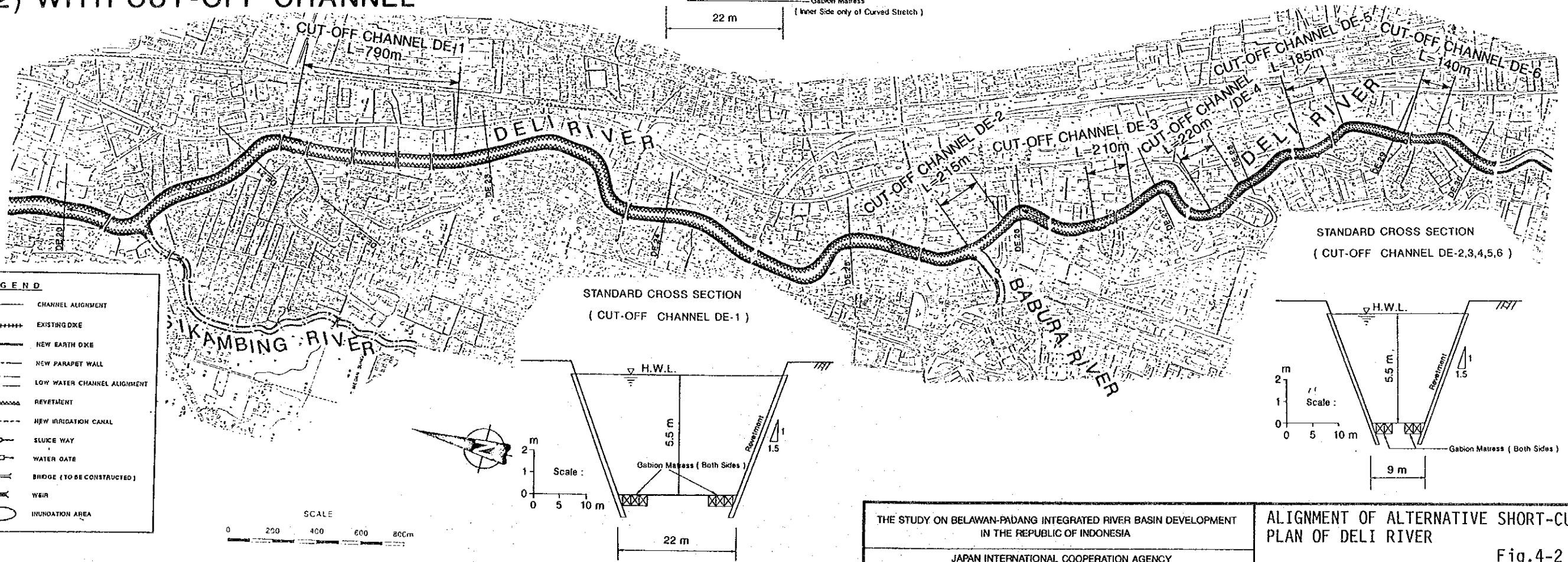

THE STUDY ON BELAWAN-PADANG INTEGRATED RIVER BASIN DEVELOPMENT
IN THE REPUBLIC OF INDONESIA

JAPAN INTERNATIONAL COOPERATION AGENCY

ALIGNMENT OF ALTERNATIVE SHORT-CUT
PLAN OF DELI RIVER

Fig.4-2

(1) EXISTING CHANNEL

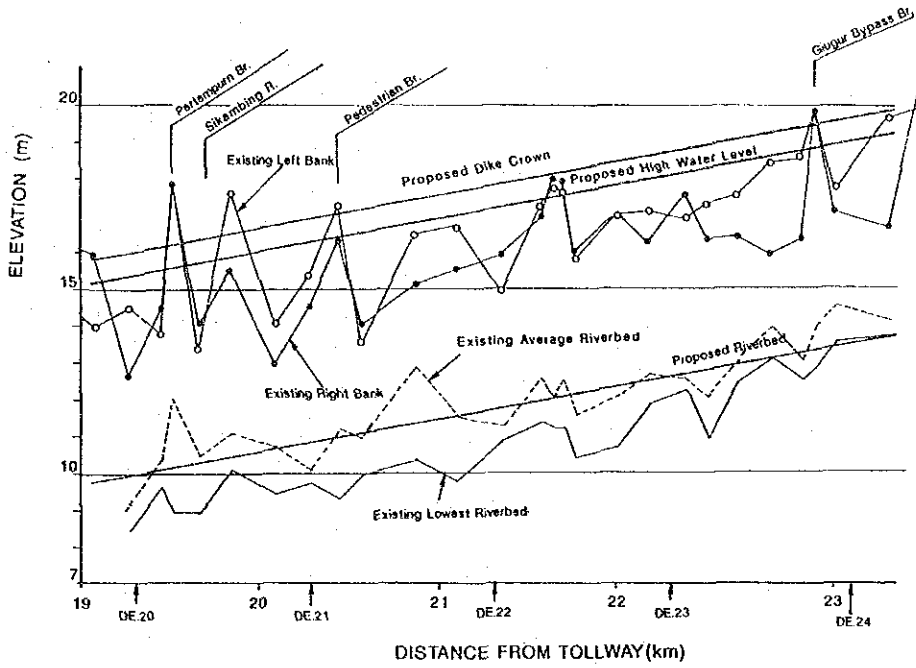

(2) WITH CUT-OFF CHANNEL

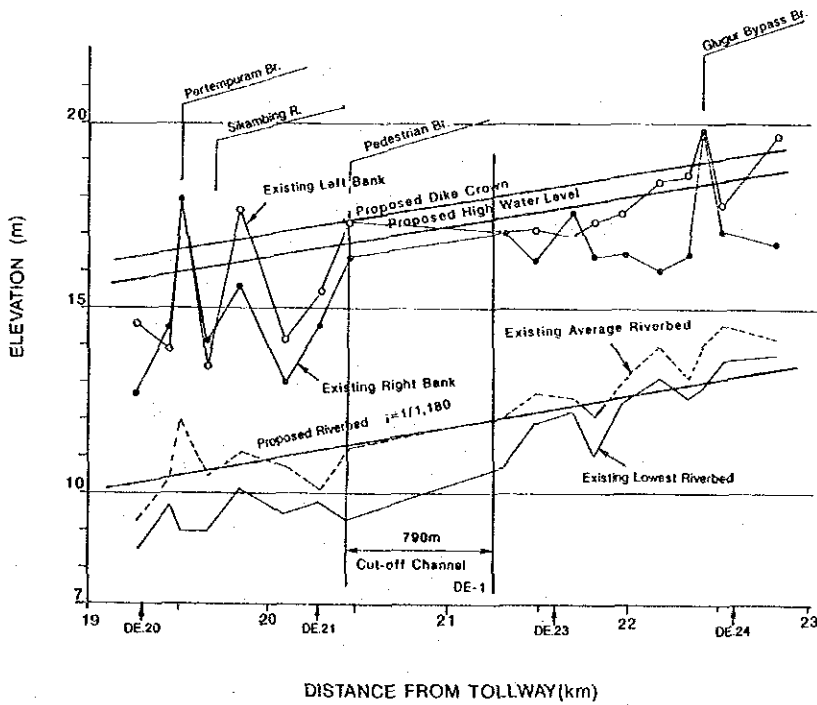

THE STUDY ON BELAWAN-PADANG INTEGRATED RIVER BASIN DEVELOPMENT
 IN THE REPUBLIC OF INDONESIA
 JAPAN INTERNATIONAL COOPERATION AGENCY

LONGITUDINAL PROFILE OF ALTERNATIVE
 SHORT-CUT PLAN OF DELI RIVER
 (DE.20 - DE.24)
 Fig.4-3(1/2)

(1) EXISTING CHANNEL

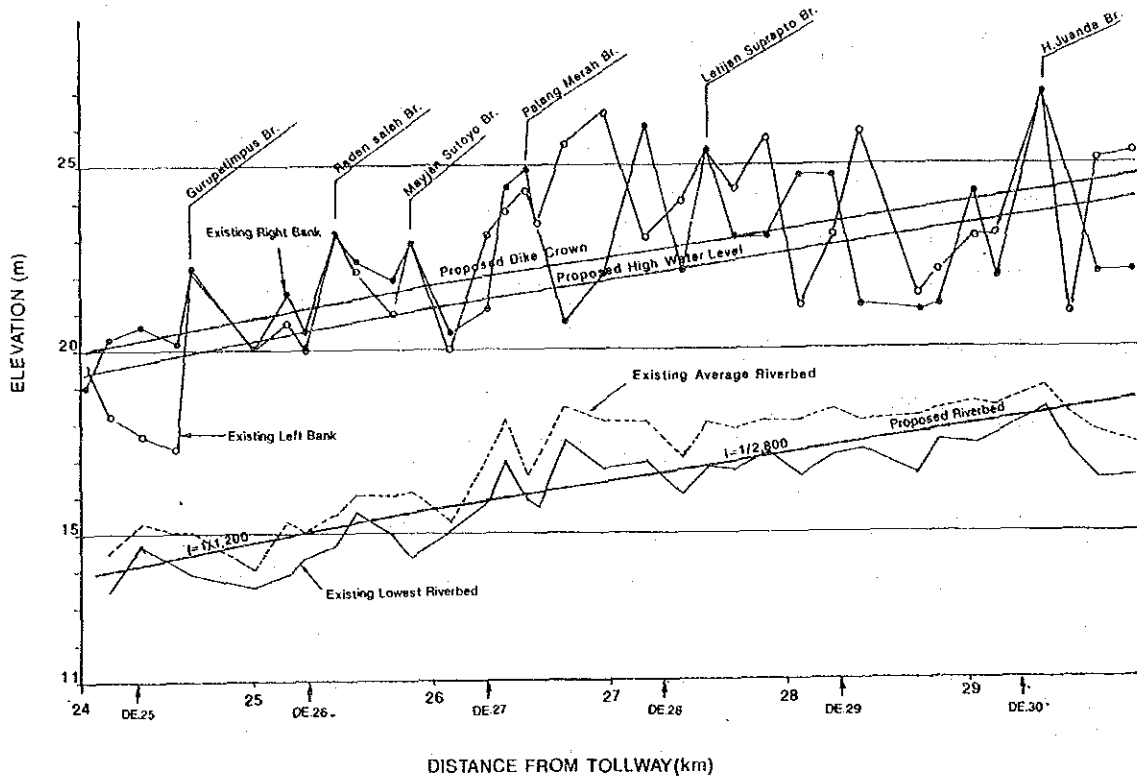

(2) WITH CUT-OFF CHANNEL

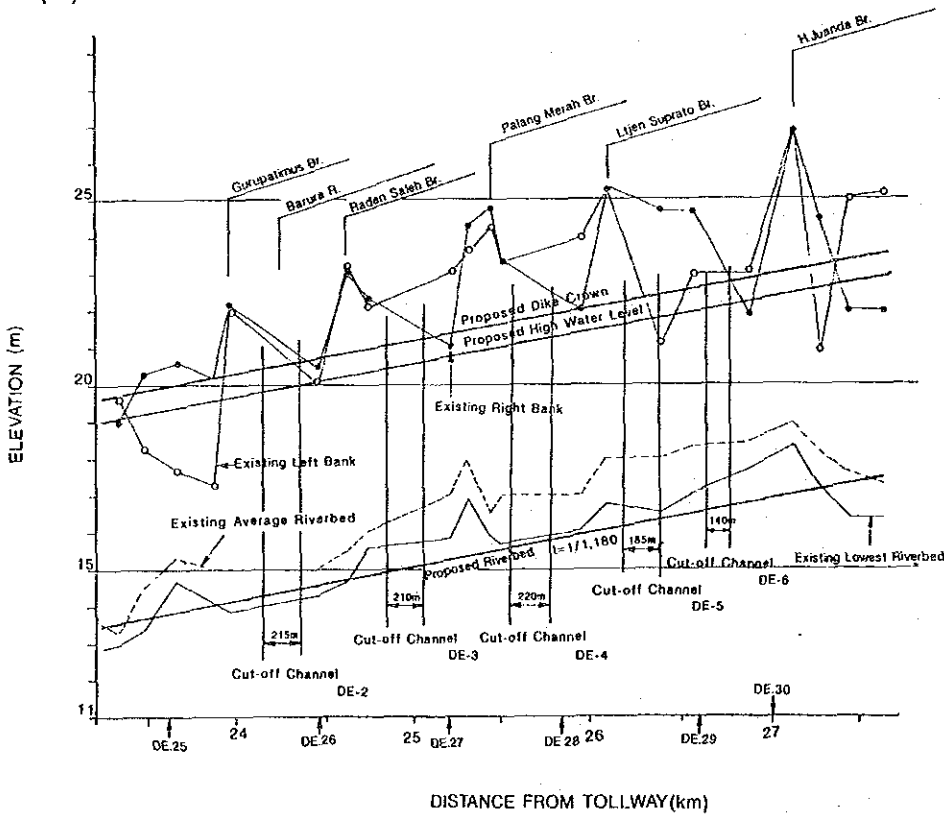

THE STUDY ON BELAWAN-PADANG INTEGRATED RIVER BASIN DEVELOPMENT
 IN THE REPUBLIC OF INDONESIA
 JAPAN INTERNATIONAL COOPERATION AGENCY

LONGITUDINAL PROFILE OF ALTERNATIVE
 SHORT-CUT PLAN OF DELI RIVER
 (DE.25 - DE.30) Fig.4-3(2/2)

(1) WITH EXISTING WEIR

TYPICAL CROSS SECTION
(PE.7 + 800)

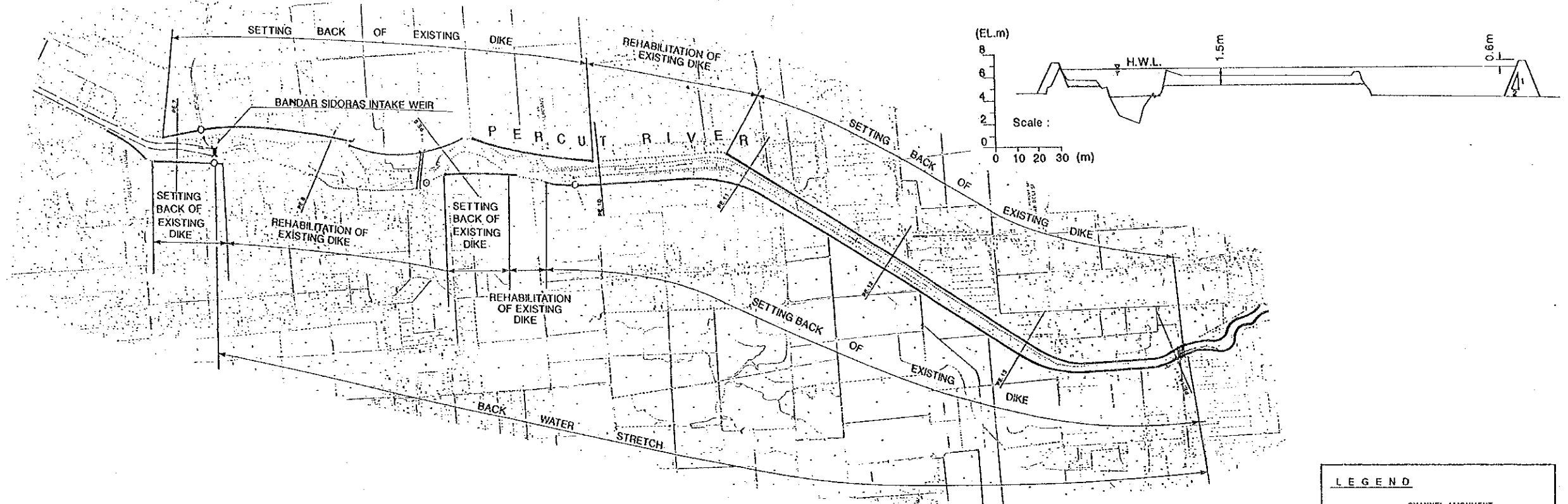

(2) WITH NEW MOVABLE WEIR

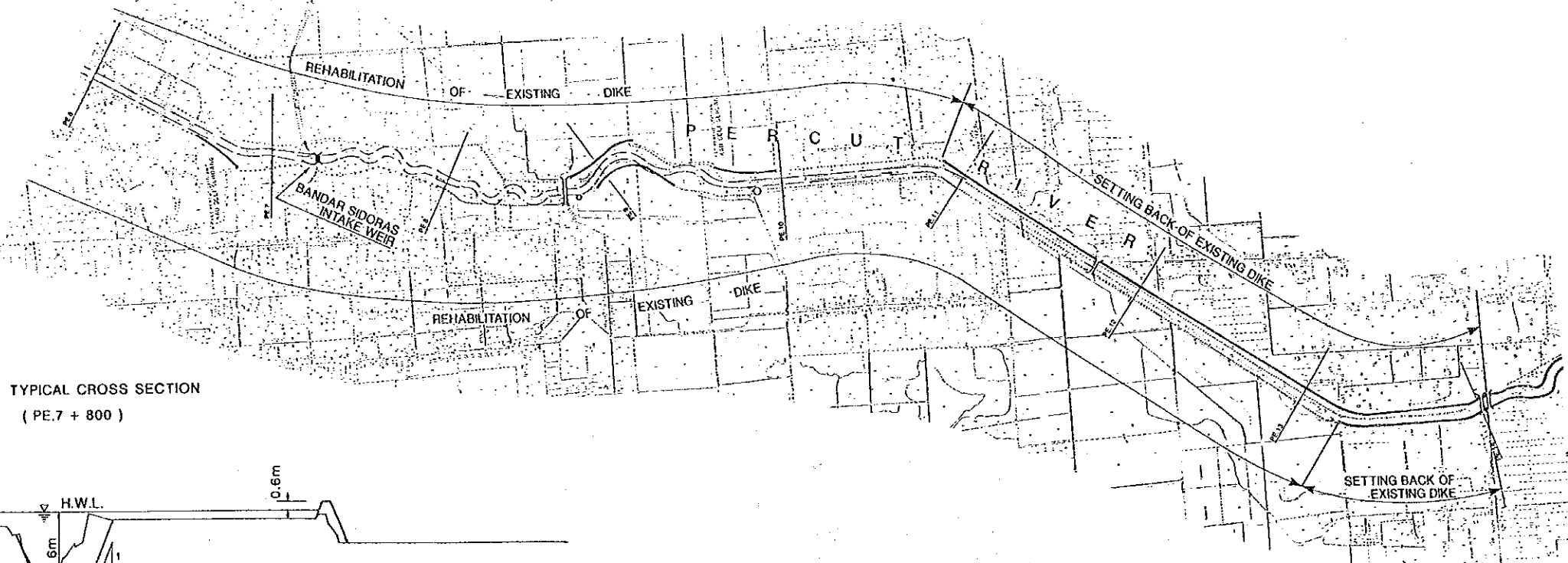

LEGEND

	CHANNEL ALIGNMENT
	EXISTING DIKE
	NEW EARTH DIKE
	NEW PARAPET WALL
	LOW WATER CHANNEL ALIGNMENT
	REVTMENT
	NEW IRRIGATION CANAL
	SLUICE WAY
	WATER GATE
	BRIDGE (TO BE CONSTRUCTED)
	WEIR
	INUNDATION AREA

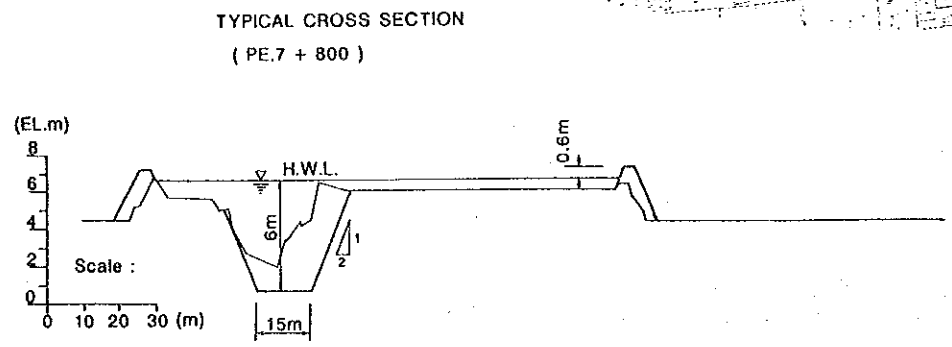
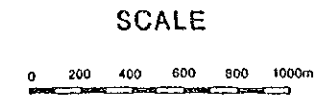

THE STUDY ON BELAWAN-PADANG INTEGRATED RIVER BASIN DEVELOPMENT
IN THE REPUBLIC OF INDONESIA
JAPAN INTERNATIONAL COOPERATION AGENCY

ALIGNMENT OF PERCUT RIVER IMPROVEMENT
RELATED TO BANDAR SIDORAS INTAKE WEIR
Fig.4-4

