

LEGEND

	CHANNEL ALIGNMENT
	EXISTING DIKE
	NEW EARTH DIKE
	NEW PARAPET WALL
	LOW WATER CHANNEL ALIGNMENT
	REVETMENT
	NEW IRRIGATION CANAL
	SLUICE WAY
	WATER GATE
	BRIDGE (TO BE CONSTRUCTED)
	WEIR
	INUNDATION AREA

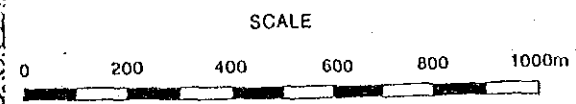

THE STUDY ON BELAWAN PANGRANG INTEGRATED RIVER BASIN DEVELOPMENT
 IN THE REPUBLIC OF INDONESIA
 JAPAN INTERNATIONAL COOPERATION AGENCY

ALIGNMENT AND TYPICAL CROSS SECTION OF
 PROPOSED DELI RIVER IMPROVEMENT WORKS
 Fig. 3-6(1/4)

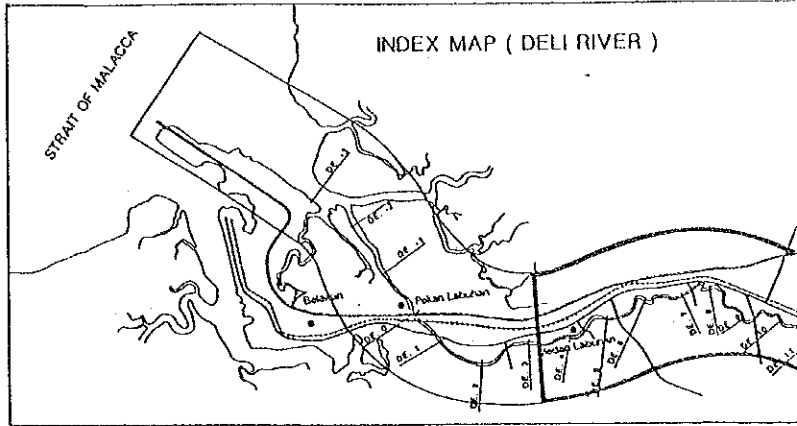
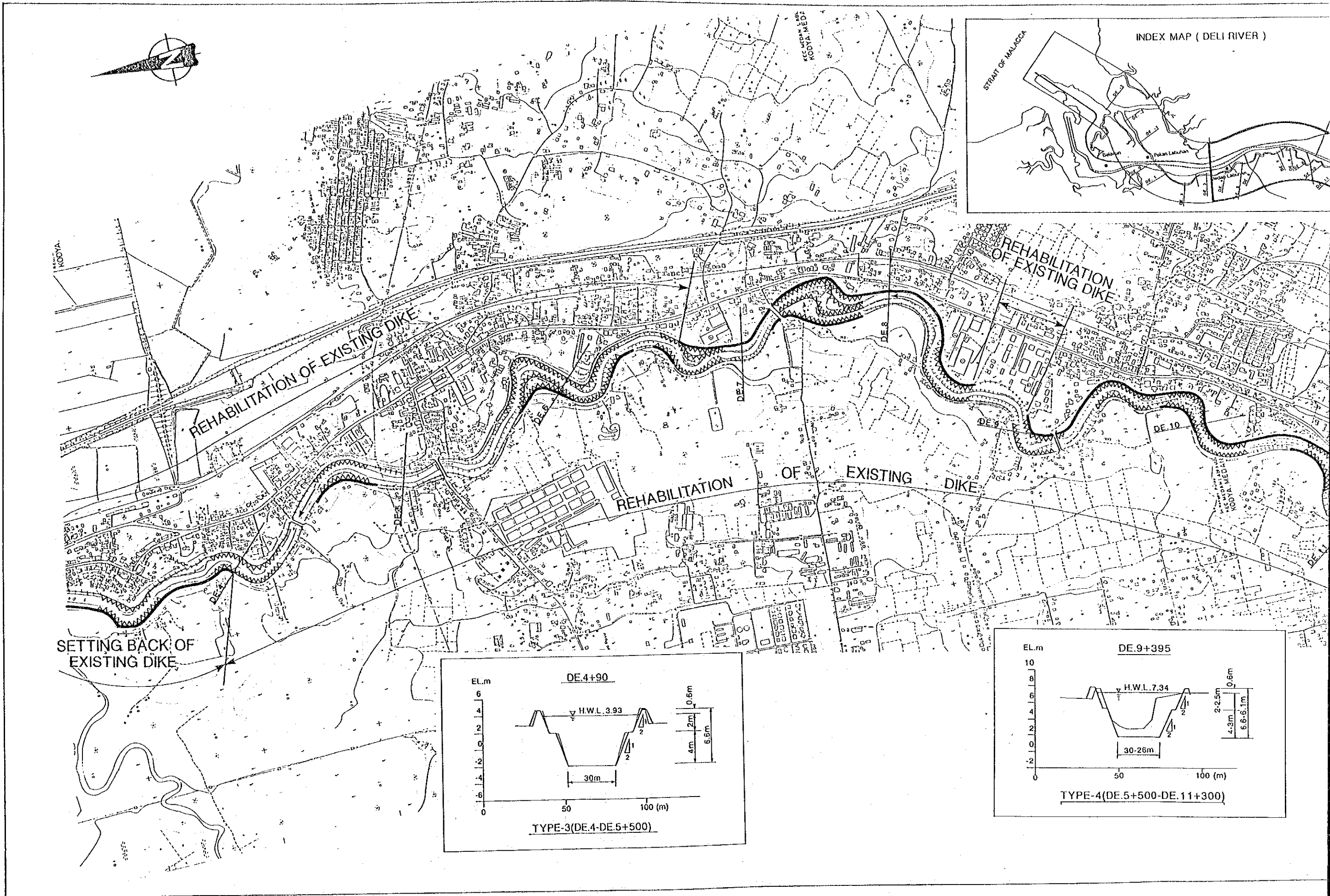

SETTING BACK OF EXISTING DIKE

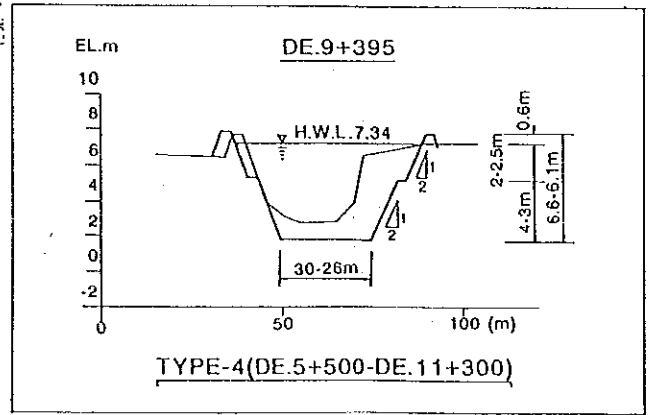
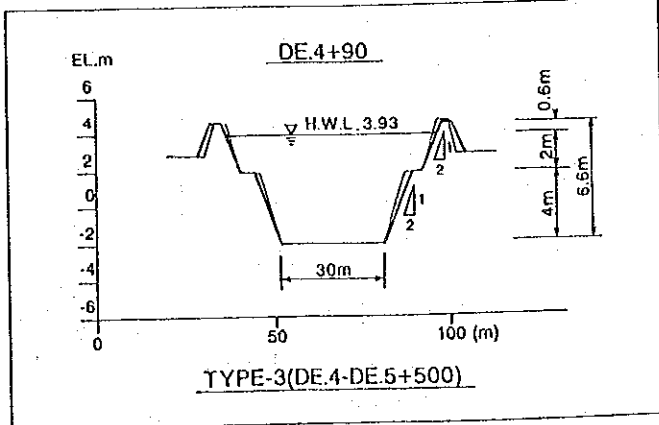

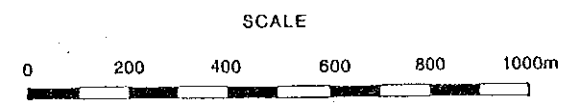
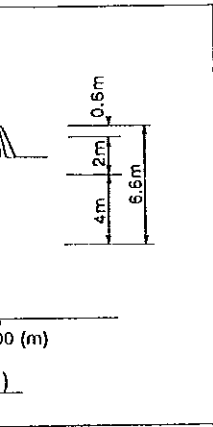
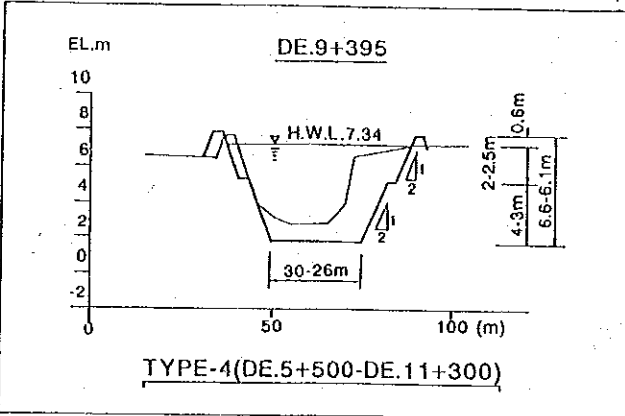
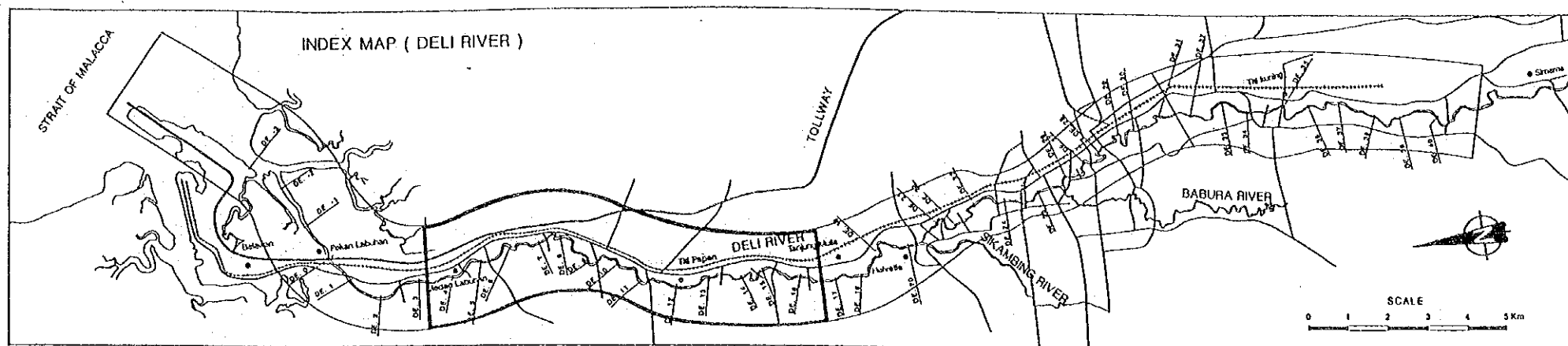
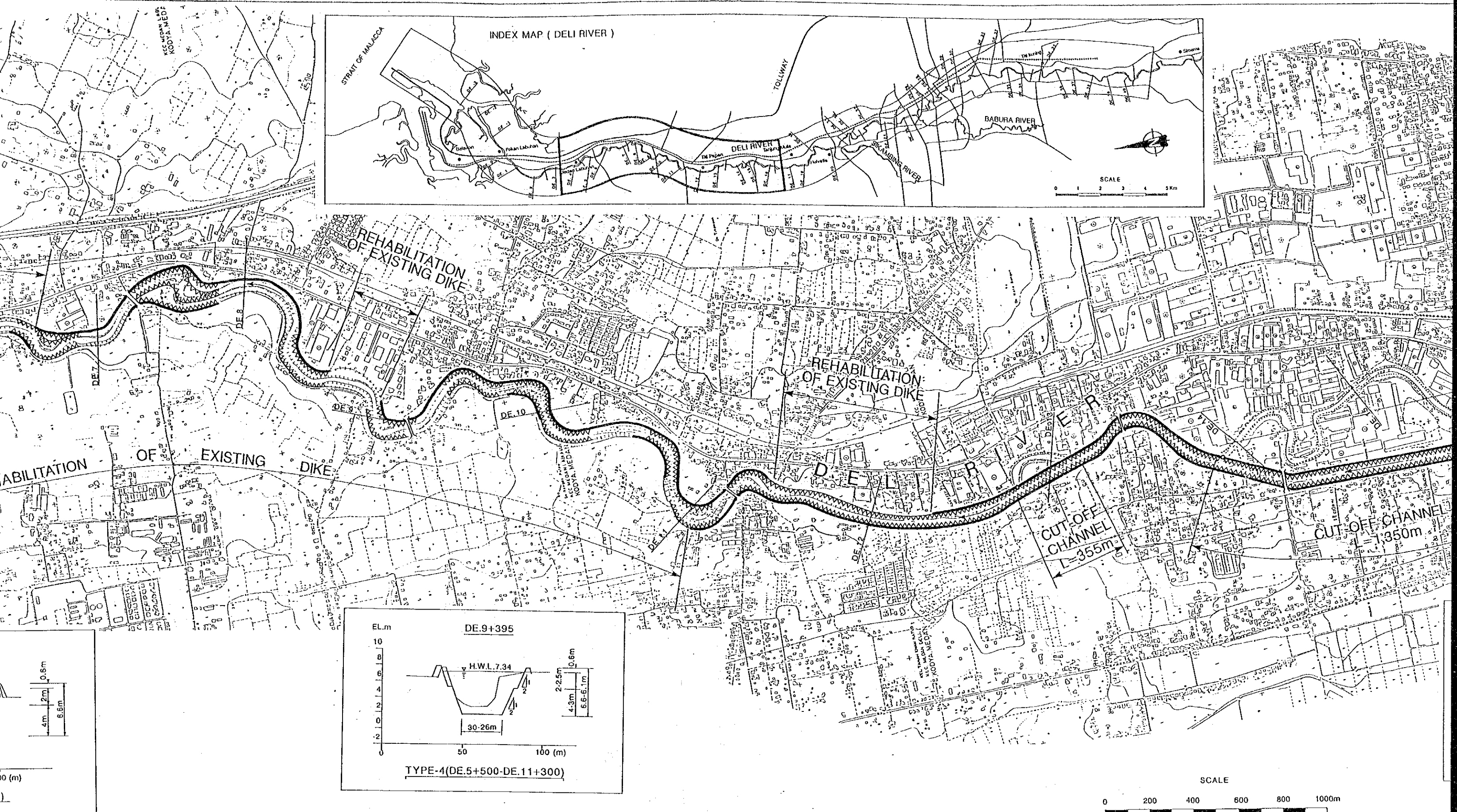

THE STUDY ON DELTA...

INDEX MAP (DELI RIVER)

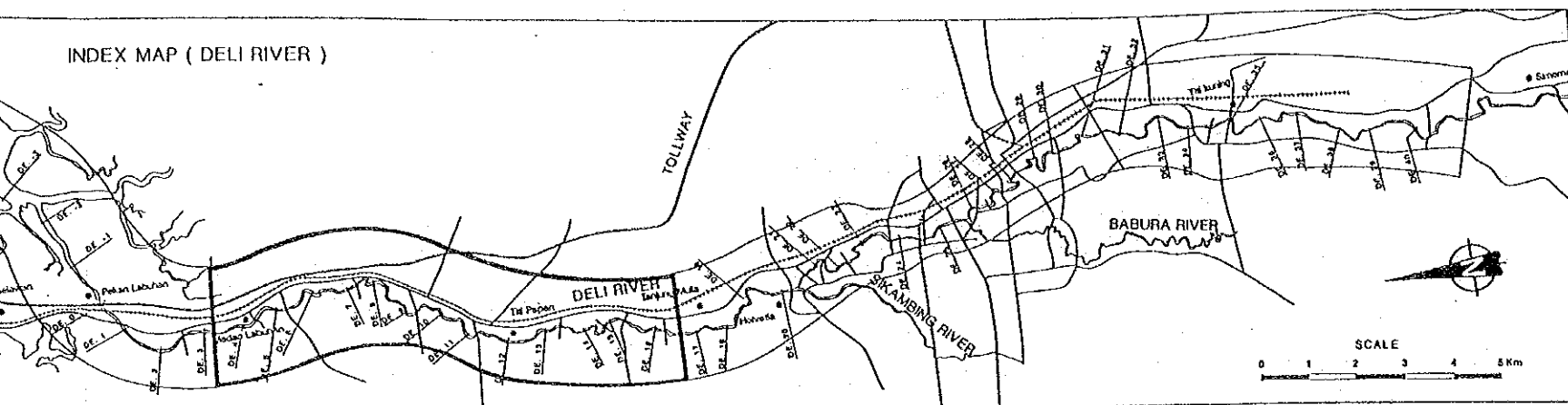

LEGEND

- CHANNEL ALIGNMENT
- +++++ EXISTING DIKE
- NEW EARTH DIKE
- - - NEW PARAPET WALL
- - - LOW WATER CHANNEL ALIGNMENT
- ~ ~ ~ REVETMENT
- - - NEW IRRIGATION CANAL
- SLUICE WAY
- WATER GATE
- () BRIDGE (TO BE CONSTRUCTED)
- ⊥ WEIR
- INUNDATION AREA

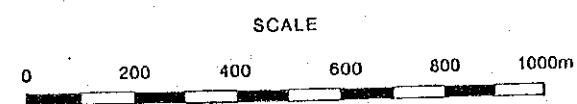
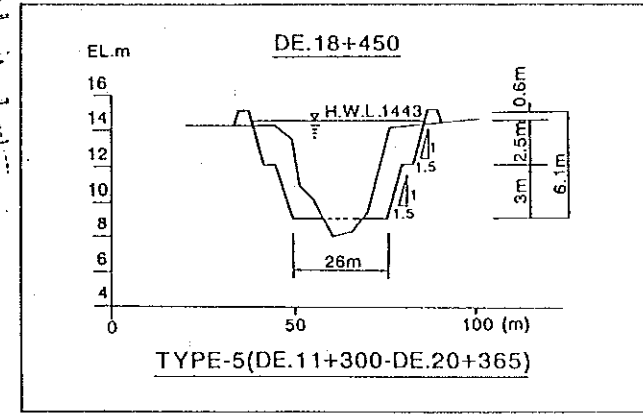
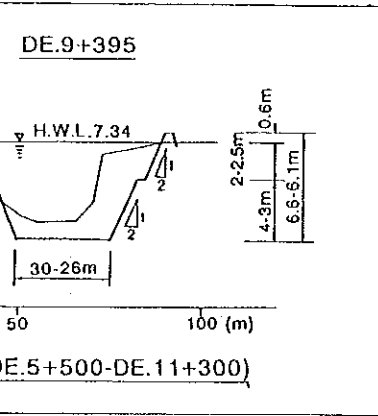
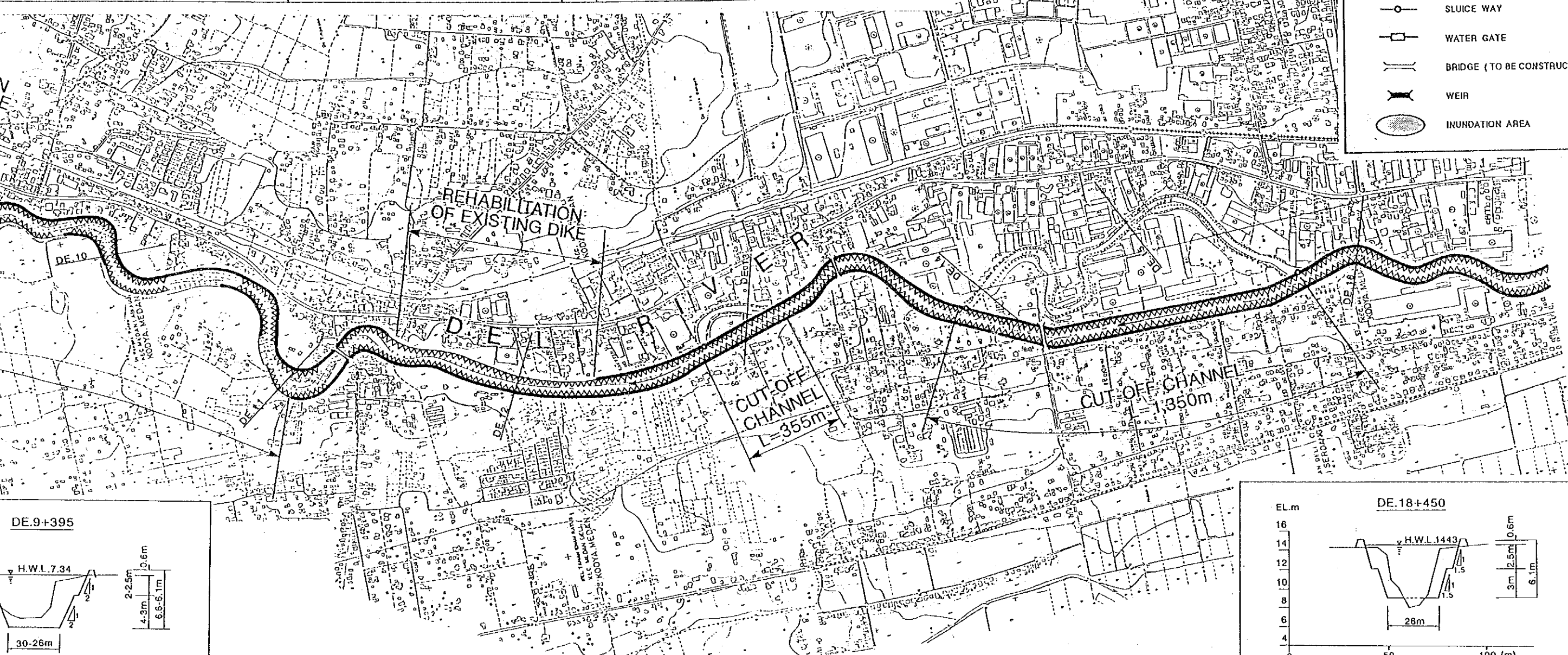

THE STUDY ON DELTA-PACIFIC INTEGRATED RIVER BASIN DEVELOPMENT
 IN THE REPUBLIC OF INDONESIA
 JAPAN INTERNATIONAL COOPERATION AGENCY

ALIGNMENT AND TYPICAL CROSS SECTION OF
 PROPOSED DELTA RIVER IMPROVEMENT WORKS
 Fig.3-6(2/4)

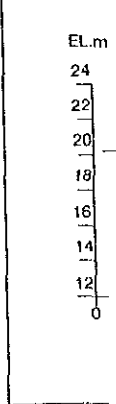
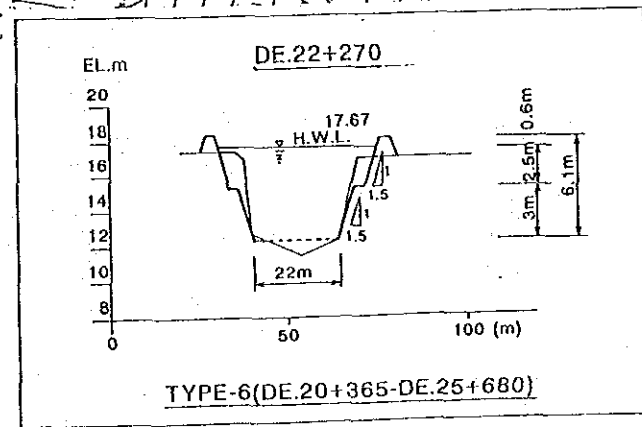
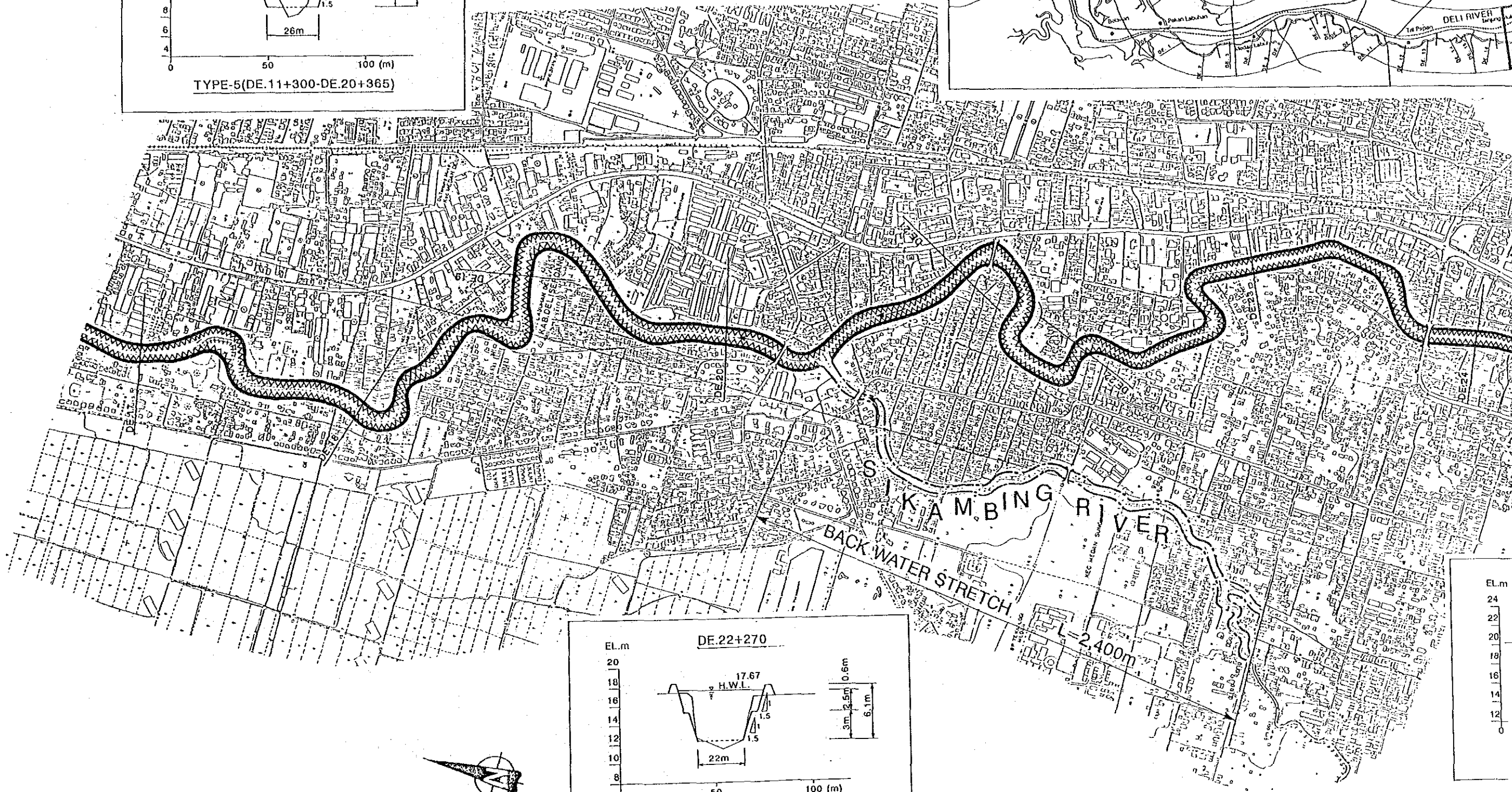
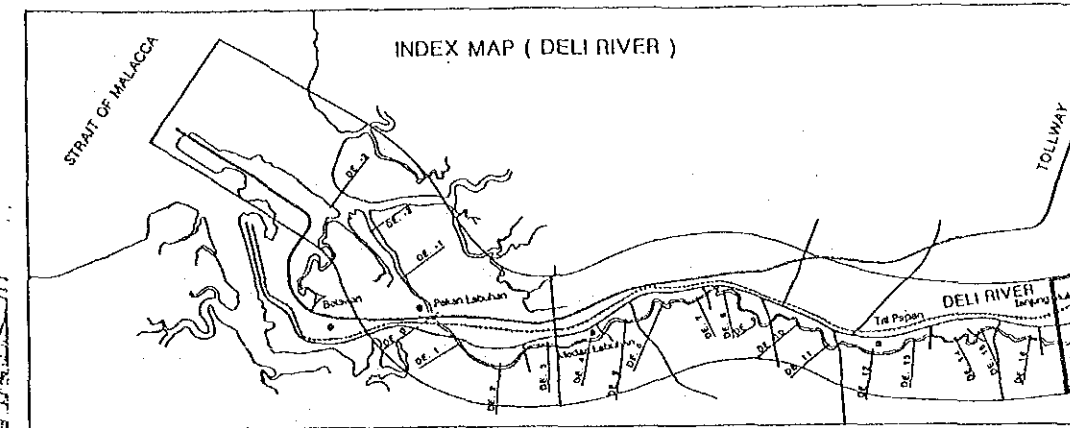
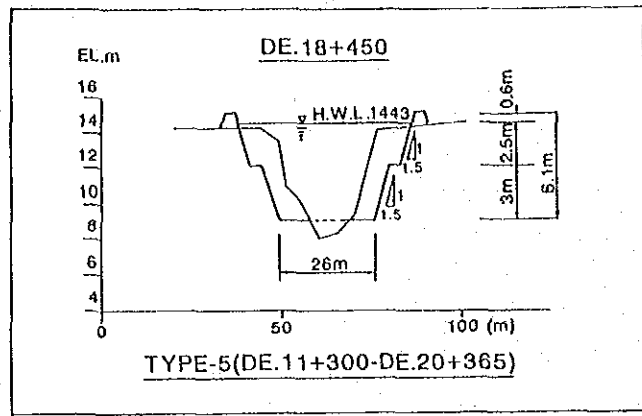

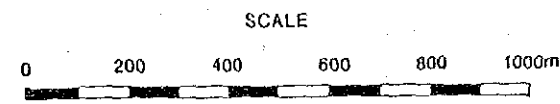
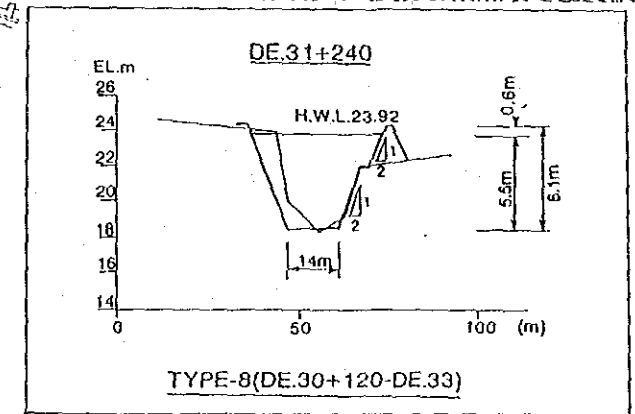
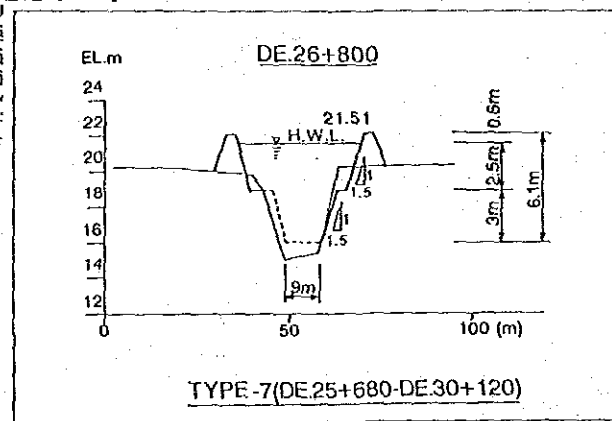
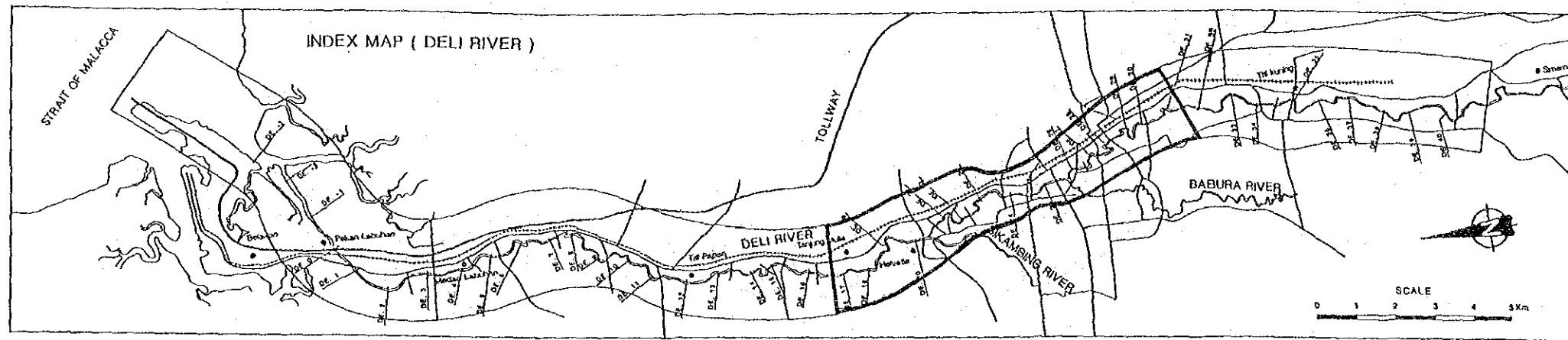

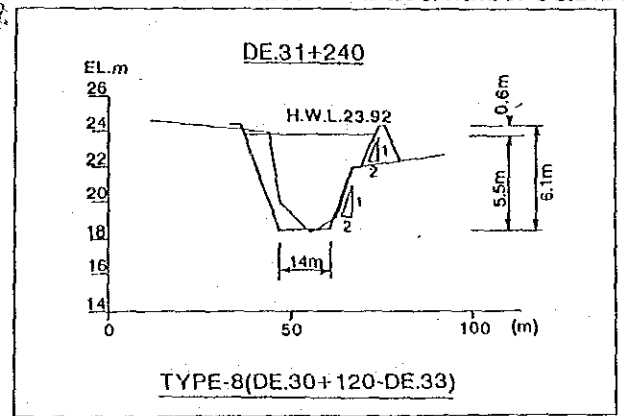
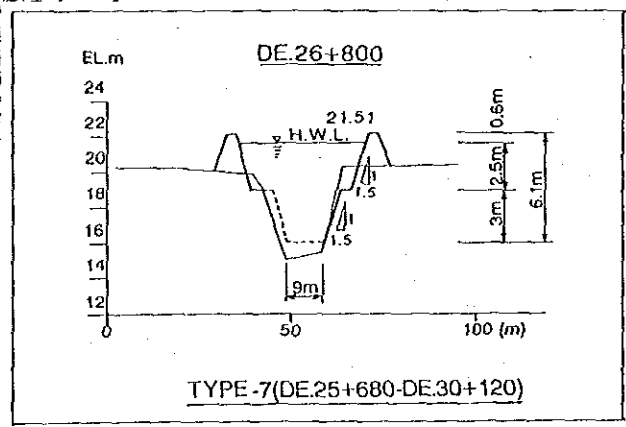
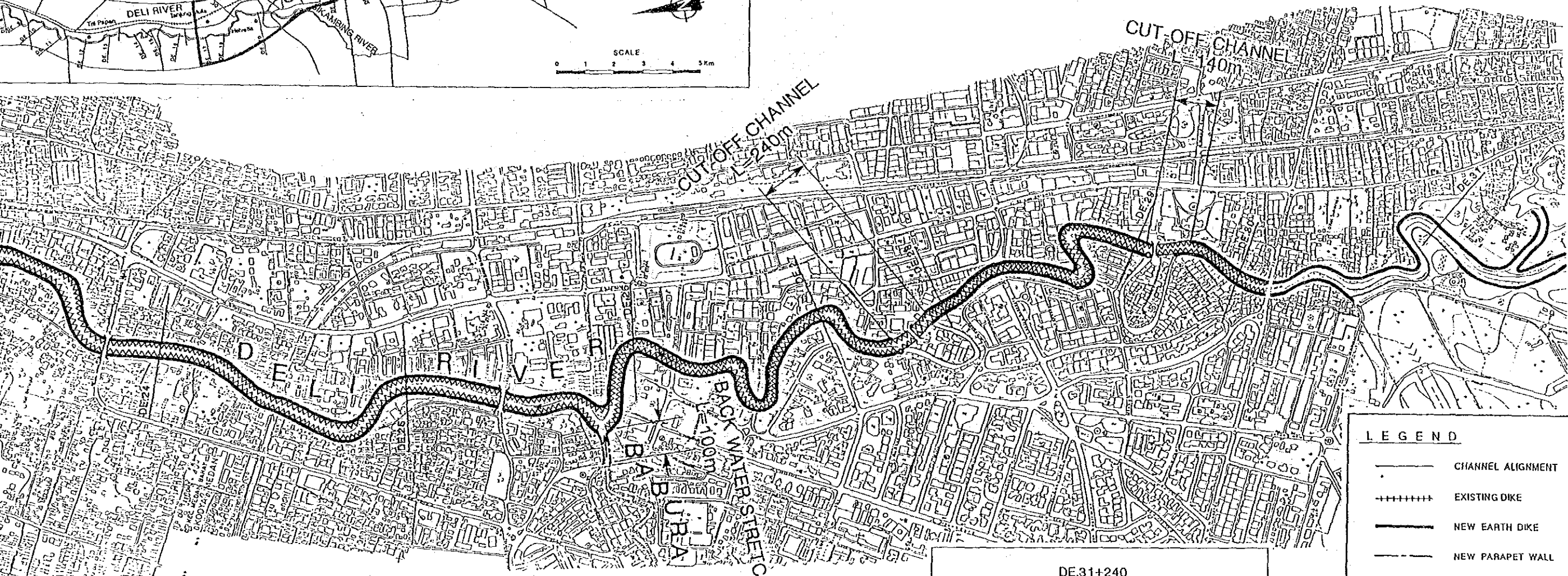
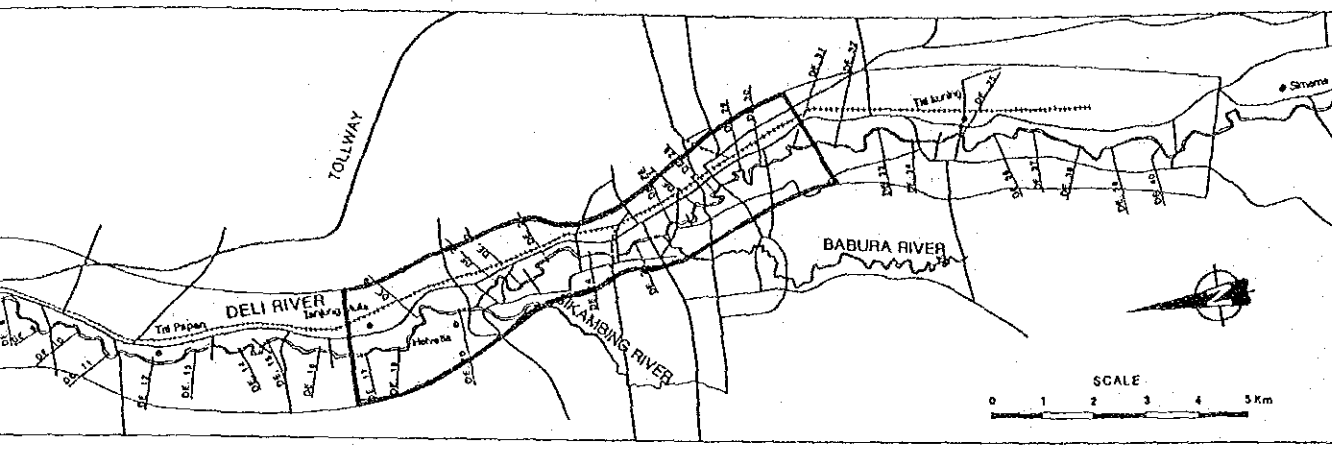

LEGEND	
	CHANNEL ALIGNMENT
	EXISTING DIKE
	NEW EARTH DIKE
	NEW PARAPET WALL
	LOW WATER CHANNEL ALIGNMENT
	REVTMENT
	NEW IRRIGATION CANAL
	SLUICE WAY
	WATER GATE
	BRIDGE (TO BE CONSTRUCTED)
	WEIR
	INUNDATION AREA

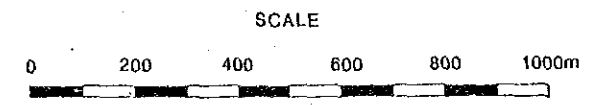

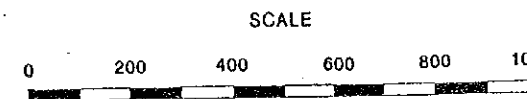
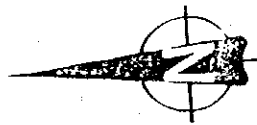
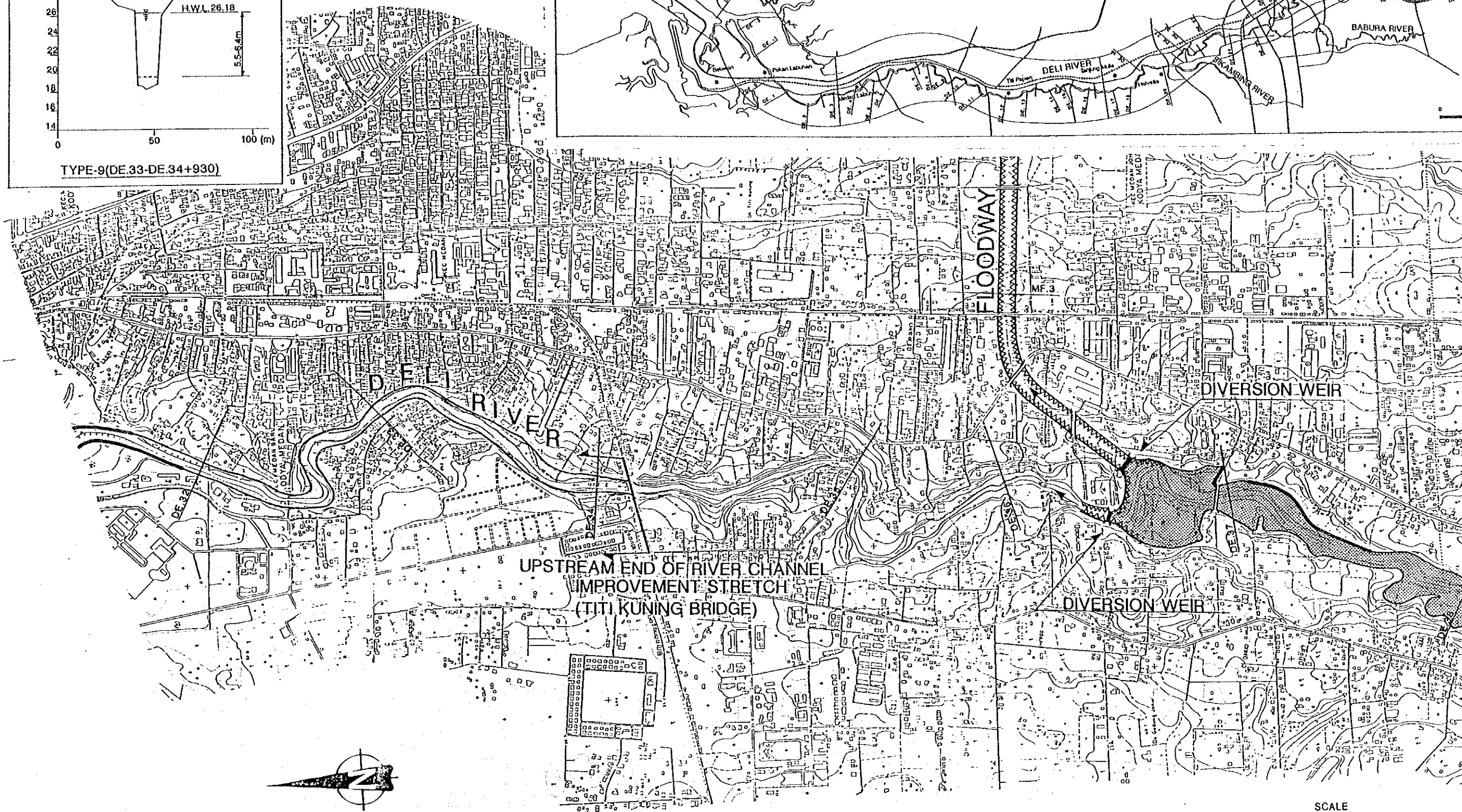
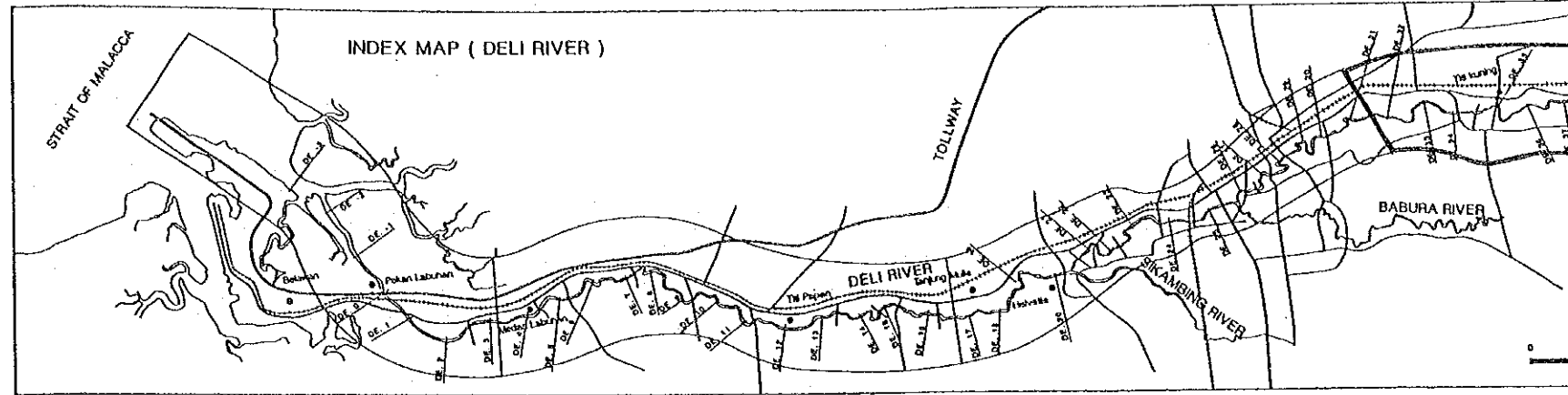
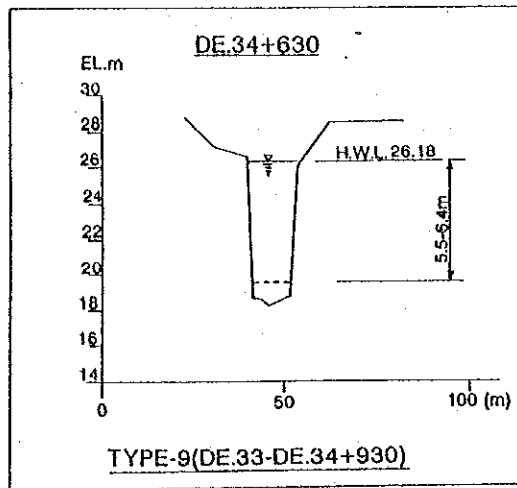

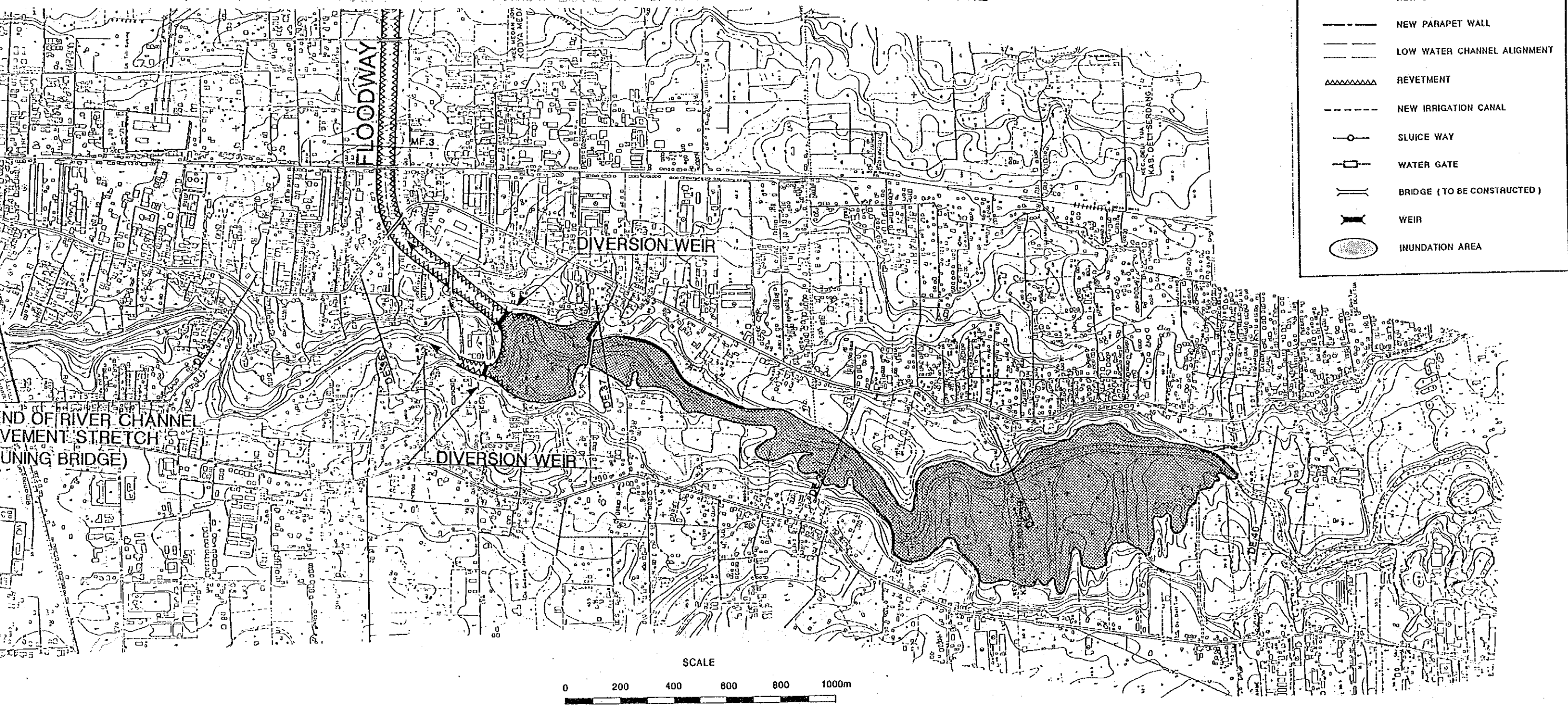
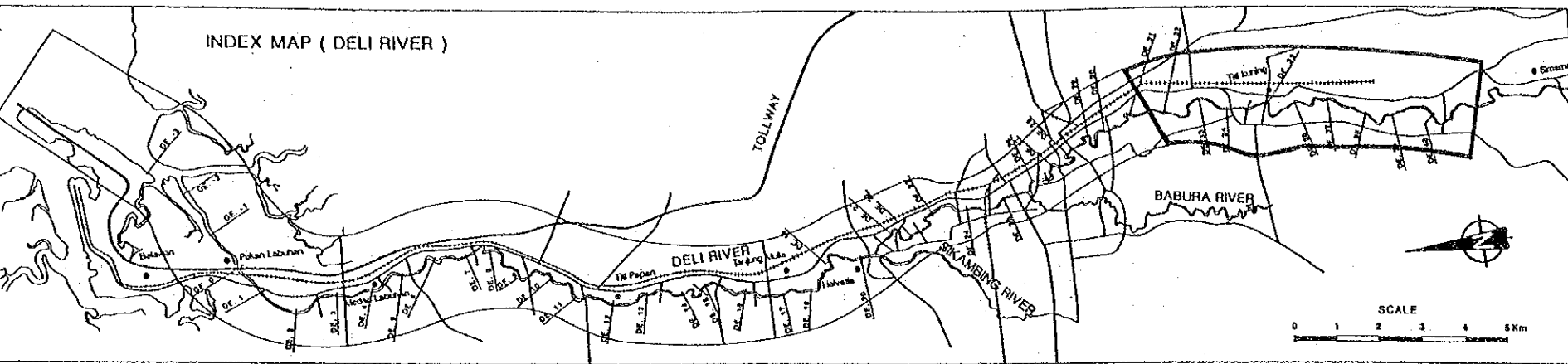

LEGEND	
	CHANNEL ALIGNMENT
	EXISTING DIKE
	NEW EARTH DIKE
	NEW PARAPET WALL
	LOW WATER CHANNEL ALIGNMENT
	REVTMENT
	NEW IRRIGATION CANAL
	SLUICE WAY
	WATER GATE
	BRIDGE (TO BE CONSTRUCTED)
	WEIR
	INUNDATION AREA

THE STUDY ON DELAWAN PONDANG INTEGRATED RIVER BASIN DEVELOPMENT
 IN THE REPUBLIC OF INDONESIA
 JAPAN INTERNATIONAL COOPERATION AGENCY

ALIGNMENT AND TYPICAL CROSS SECTION OF
 PROPOSED DELTA RIVER IMPROVEMENT WORKS
 Fig.3-6(4/4)

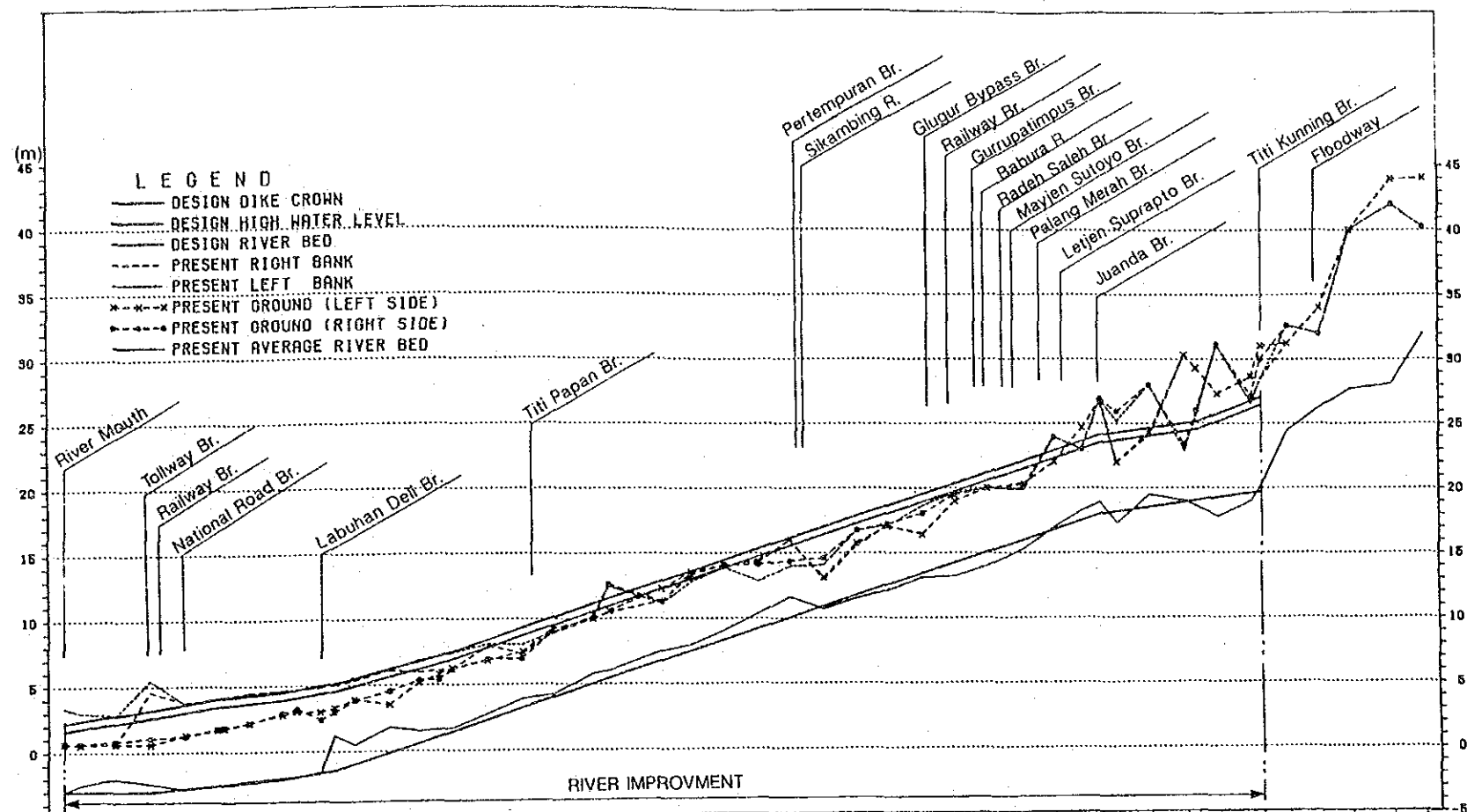

Gradient of Design Riverbed		Level	1/4,500	1/2,300	1/1,180	1/2,800																																												
Design Elevation (m)	Dike Crown	2.20	2.59	2.79	3.02	3.62	4.10	4.27	4.49	4.87	5.14	5.54	6.21	6.78	7.15	7.62	8.42	9.31	10.00	12.00	13.02	14.47	16.24	18.61	20.34	22.11	22.91	23.03	23.82	24.12	24.30	24.85	25.78	28.78	27.00															
	High Water	1.80	1.75	2.19	2.60	3.02	3.62	3.87	4.49	4.87	5.14	5.54	6.21	6.78	7.15	7.62	8.42	9.31	10.00	12.00	13.02	14.47	16.24	18.61	20.34	22.11	22.91	23.03	23.82	24.12	24.30	24.85	25.78	28.78	27.00															
	Riverbed	-3.00	-3.00	-3.00	-3.00	-2.77	-2.80	-2.53	-2.11	-1.83	-1.63	-1.48	-1.07	-0.92	-0.71	-0.49	0.00	0.22	0.71	0.92	0.79	0.62	0.37	0.24	0.08	0.41	1.04	1.81	1.85	18.02	19.04	19.27	19.65	20.18	20.49															
Present Elevation (m)	Right Ground	0.64	0.68	0.65	0.68	1.31	1.70	2.19	3.04	3.27	3.87	4.84	5.63	6.18	6.58	7.47	8.23	9.23	10.00	12.24	13.68	14.04	14.28	15.98	18.41	19.04	19.27	19.65	20.00	20.34	20.54	20.78	21.14	21.42	21.80	24.00	24.60													
	Left Ground	0.88	0.82	0.86	1.07	1.81	1.73	2.18	3.24	3.50	4.87	5.85	6.53	7.36	8.16	9.08	10.16	11.25	12.24	14.48	16.76	17.24	18.06	18.43	19.43	20.00	20.34	20.54	20.95	21.33	21.50	21.78	22.00	22.24	22.50	22.88	23.33	23.80	24.00											
	Average Riverbed	-3.00	-2.80	-2.00	-2.40	-2.80	-2.80	-2.20	-1.90	-1.70	-1.00	-0.50	1.00	1.50	1.70	2.00	2.80	3.80	4.20	7.60	8.00	9.10	10.40	11.60	14.60	18.00	20.00	20.54	21.00	21.50	22.00	22.50	23.00	23.50	24.00	24.50	25.00	25.50												
Distance	accum. (km)	0.000	0.029	0.058	0.087	0.174	0.261	0.348	0.696	1.044	1.392	2.184	2.576	3.264	3.656	4.344	5.136	5.928	6.720	9.168	10.416	11.664	12.912	14.160	17.616	19.008	19.400	19.792	20.184	20.576	20.968	21.360	21.752	22.144	22.536	22.928	23.320	23.712	24.104											
	partial (m)	0	471	1000	1029	1086	1143	1200	1257	1314	1371	1428	1485	1542	1600	1657	1714	1771	1828	1885	1942	2000	2057	2114	2171	2228	2285	2342	2400	2457	2514	2571	2628	2685	2742	2800	2857	2914	2971											
Station No.		DE-3 +800	DE-3 +871	DE-2 +971	DE-017-H	DE-1 + 85	DE-2 +885	DE-3 + 50	DE-4	DE-4 +420	DE-5 + 85	DE-5 +600	DE-6 + 80	DE-7 + 75	DE-7 +810	DE-8 +800	DE-9 +900	DE-9 +800	DE-10 + 15	DE-11 + 825	DE-11 + 800	DE-12 + 810	DE-13 + 820	DE-14 + 830	DE-15 + 840	DE-16 + 850	DE-17 + 860	DE-18 + 870	DE-19 + 880	DE-20 + 890	DE-21 + 900	DE-22 + 910	DE-23 + 920	DE-24 + 930	DE-25 + 940	DE-26 + 950	DE-27 + 960	DE-28 + 970	DE-29 + 980	DE-30 + 990	DE-31 + 810	DE-32 + 865	DE-33	DE-34 + 830	DE-35 + 820	DE-36 + 755	DE-38 + 720	DE-37 + 710	DE-38 + 860	DE-39 + 820

THE STUDY ON BELAWAN-PADANG INTEGRATED RIVER BASIN DEVELOPMENT
IN THE REPUBLIC OF INDONESIA
JAPAN INTERNATIONAL COOPERATION AGENCY

LONGITUDINAL PROFILE OF PROPOSED DELI RIVER IMPROVEMENT WORKS
Fig.3-7

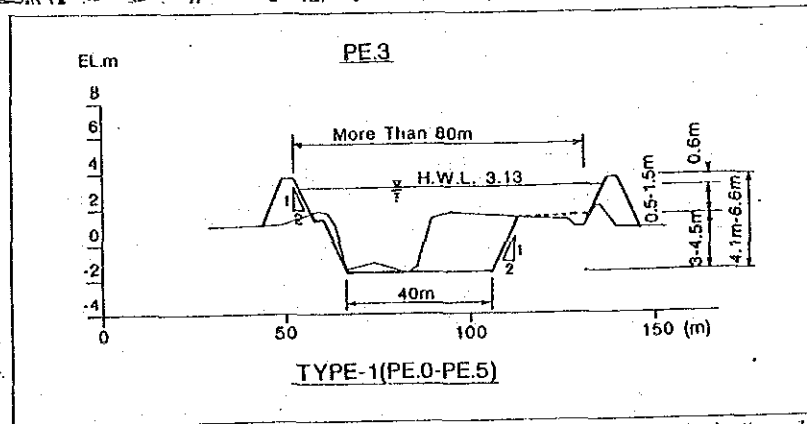
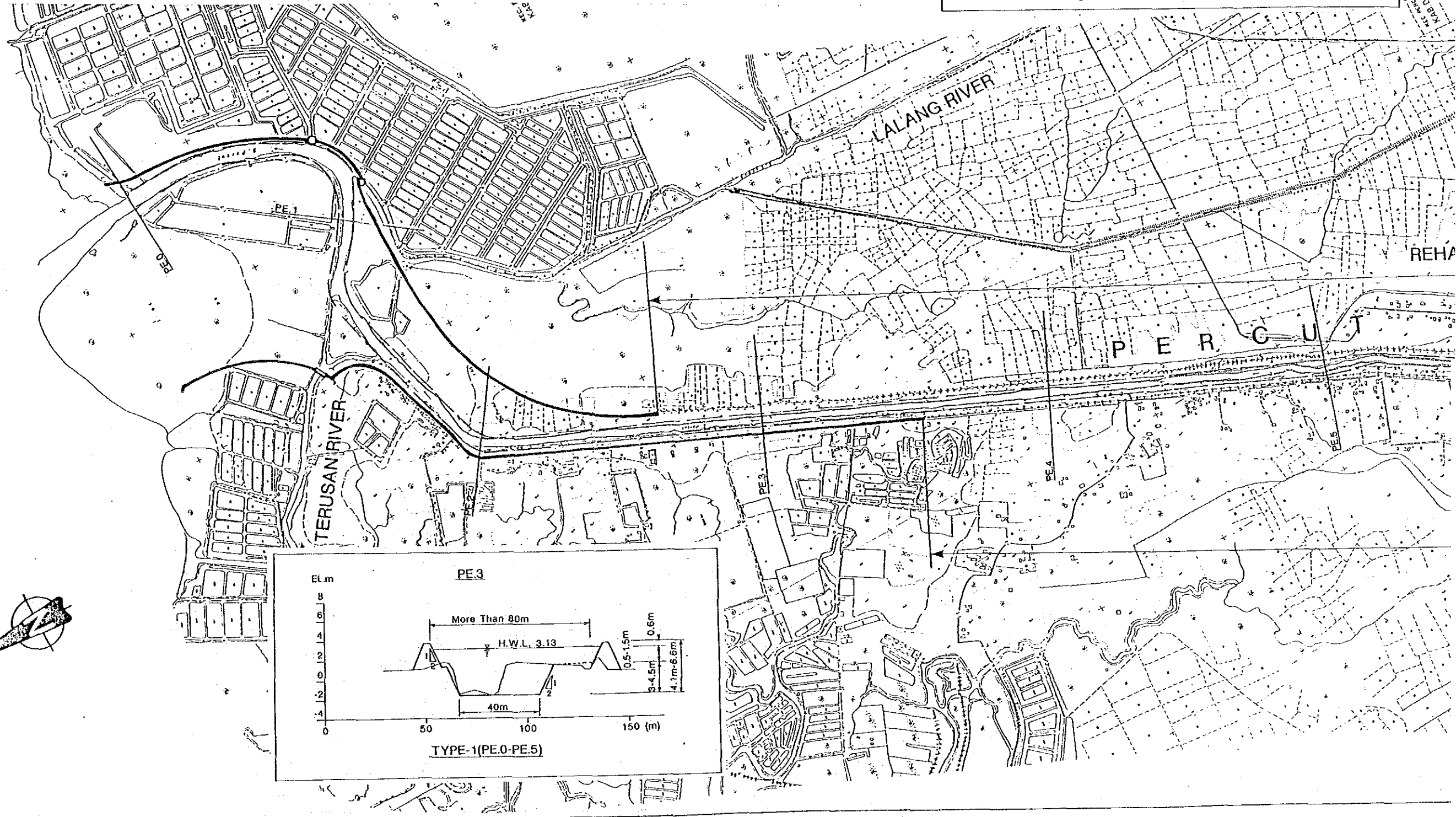
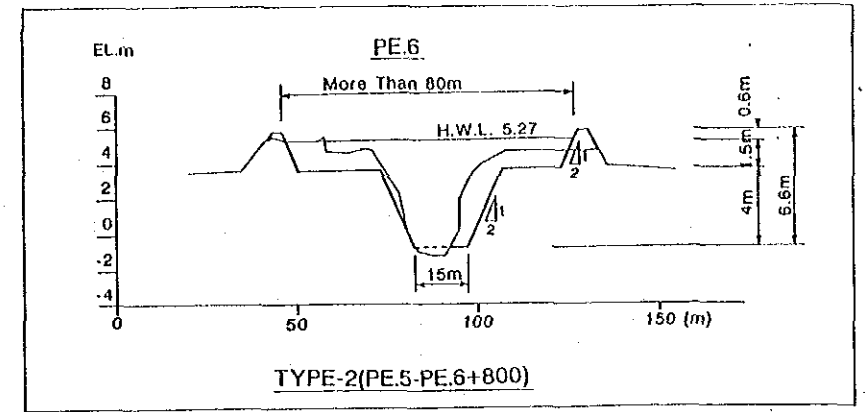
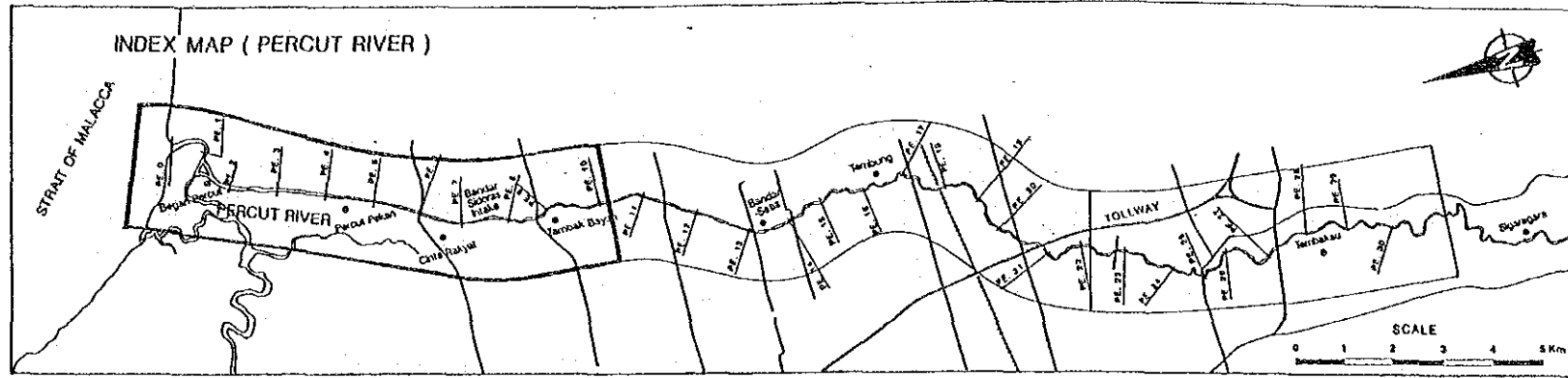

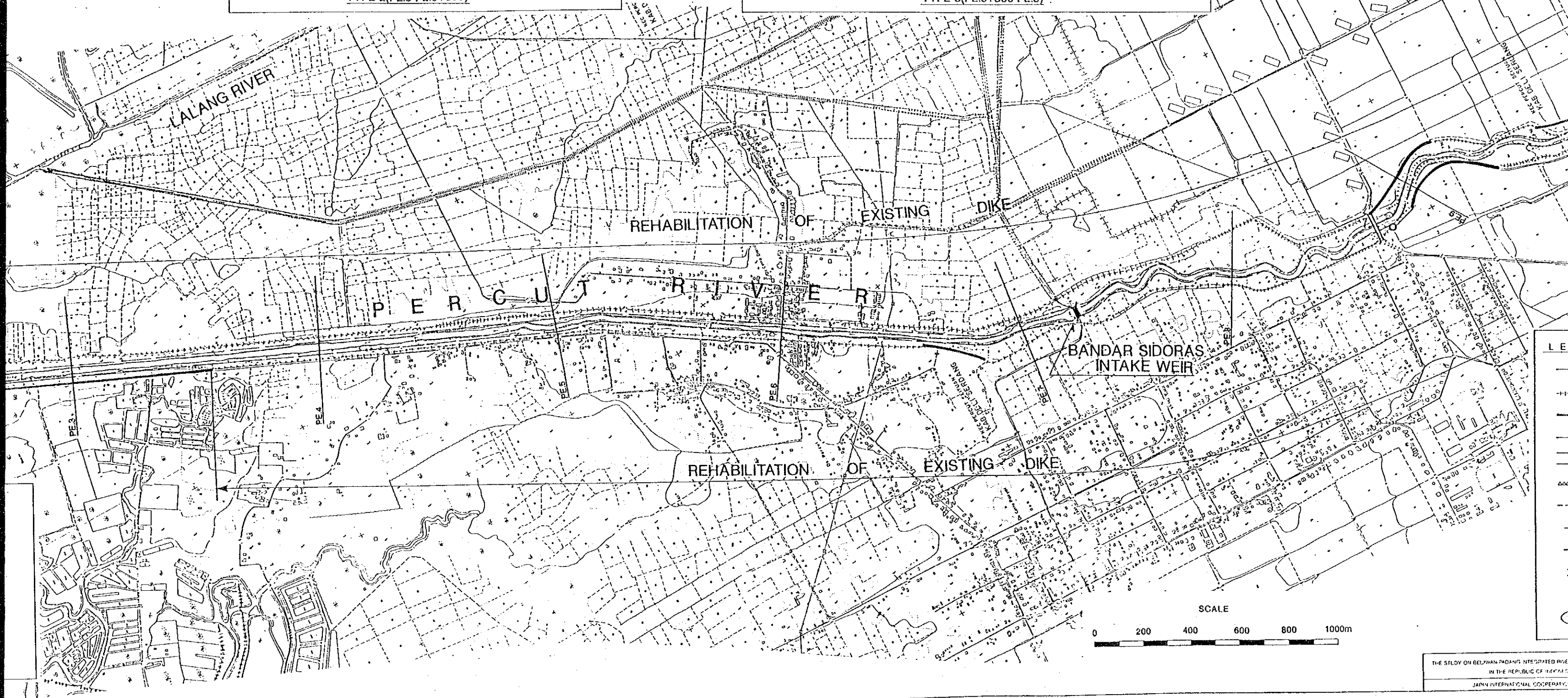
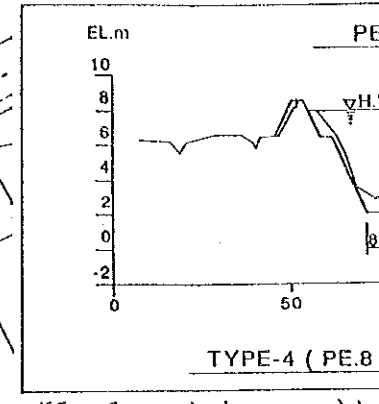
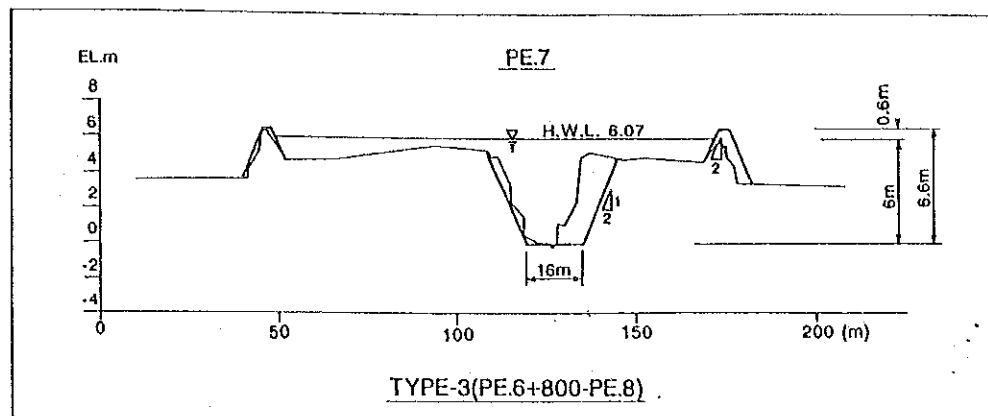
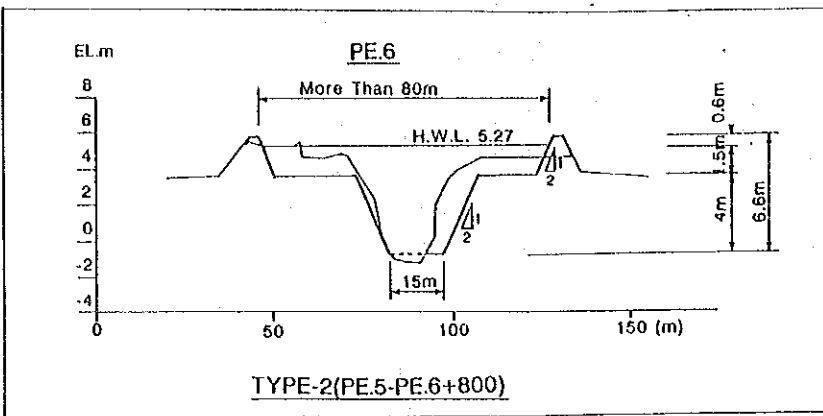
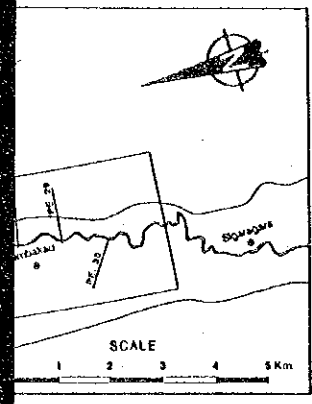

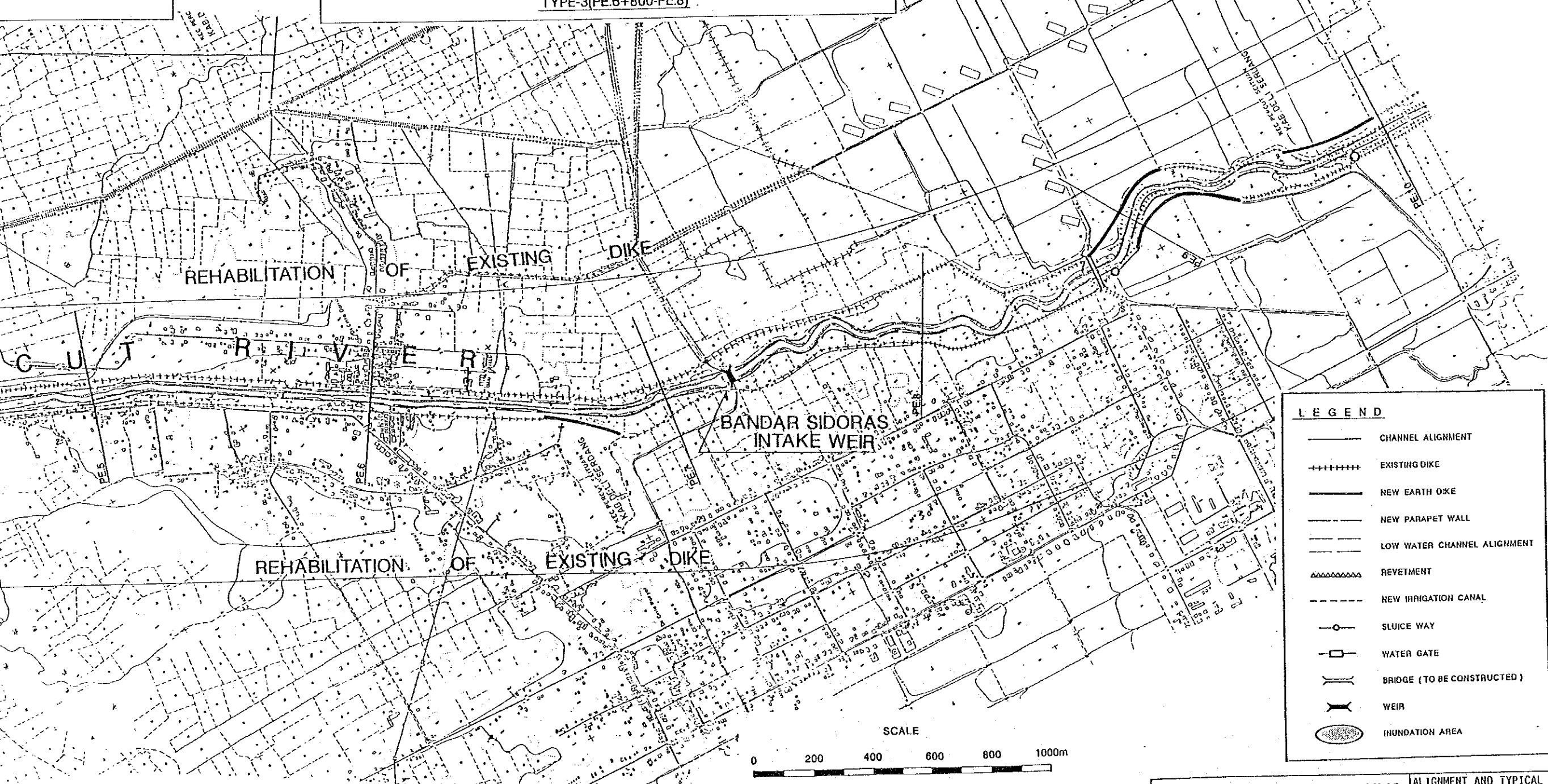
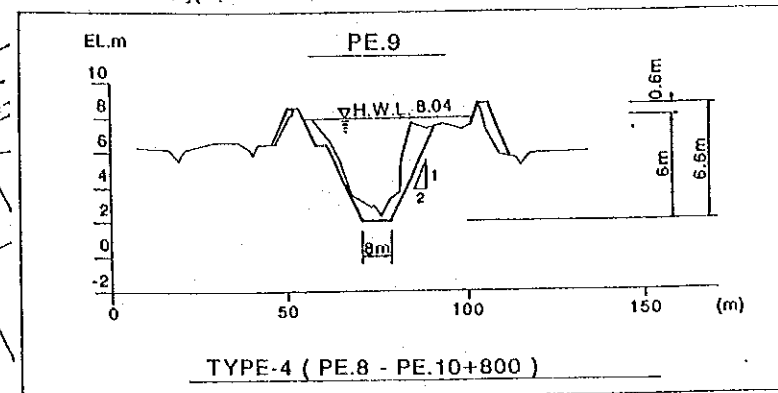
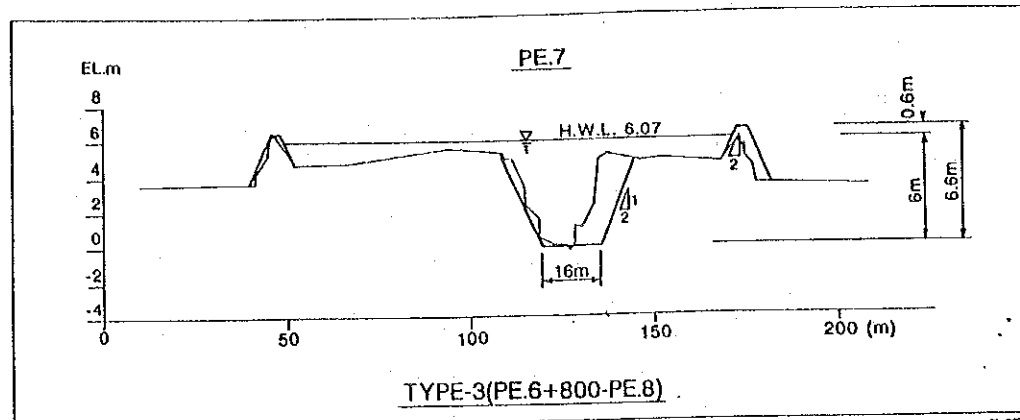
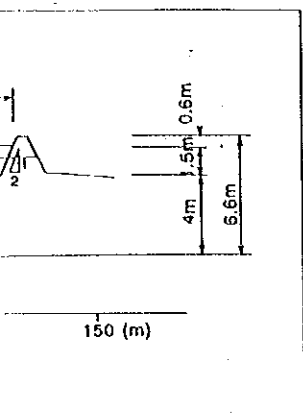

LEGEND

- CHANNEL ALIGNMENT
- +++++ EXISTING DIKE
- NEW EARTH DIKE
- NEW PARAPET WALL
- - - LOW WATER CHANNEL ALIGNMENT
- ▲▲▲▲ REVTMENT
- - - NEW IRRIGATION CANAL
- SLUICE WAY
- WATER GATE
- || BRIDGE (TO BE CONSTRUCTED)
- ⊥ WEIR
- INUNDATION AREA

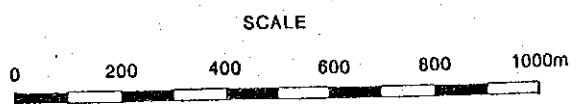

THE SILOY ON BELAWANPOANG INTEGRATED RIVER BASIN DEVELOPMENT
 IN THE REPUBLIC OF INDONESIA
 JAPAN INTERNATIONAL COOPERATION AGENCY

ALIGNMENT AND TYPICAL CROSS SECTION OF
 PROPOSED PERCUT RIVER IMPROVEMENT
 WORKS
 Fig. 3-8 (1/3)

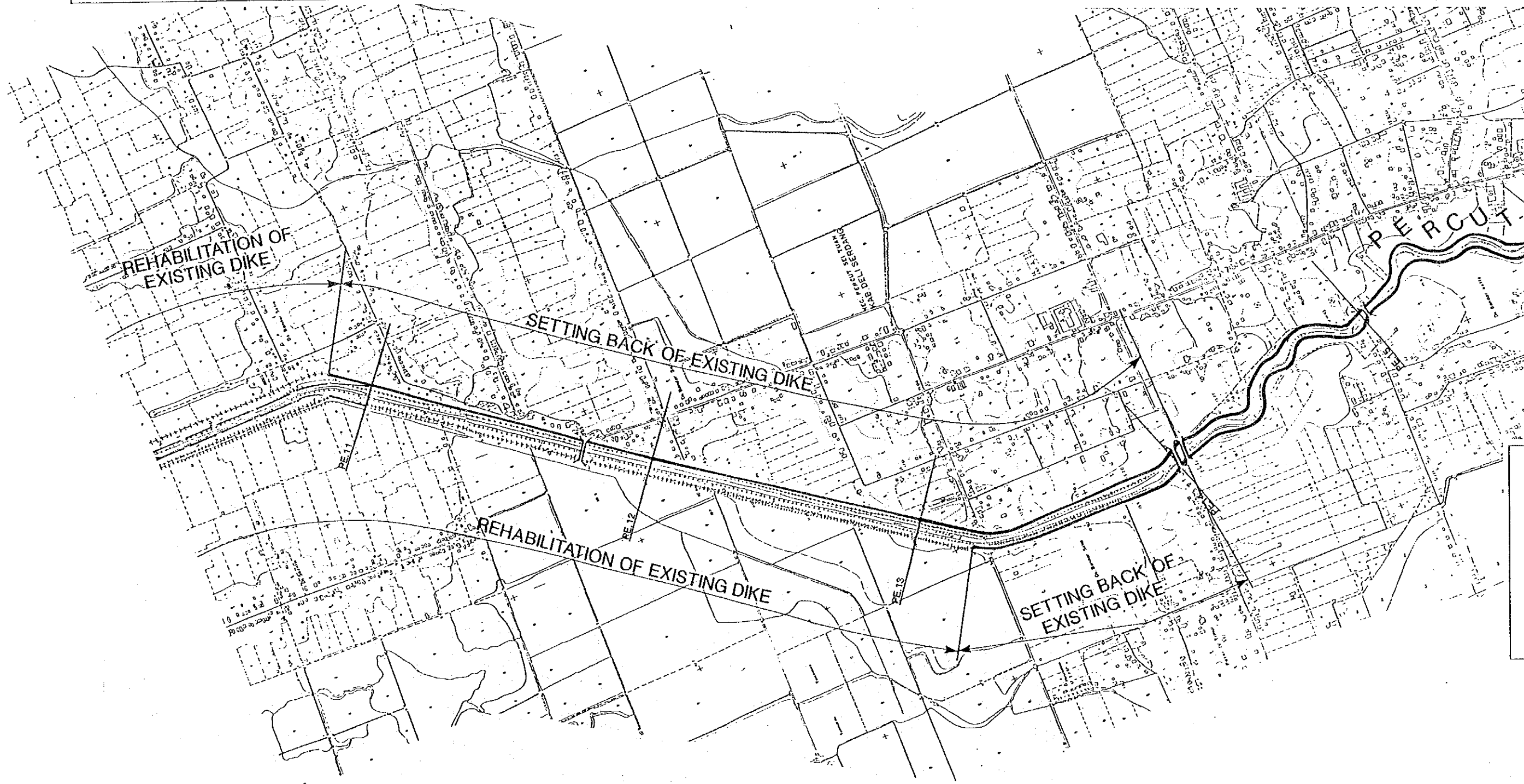
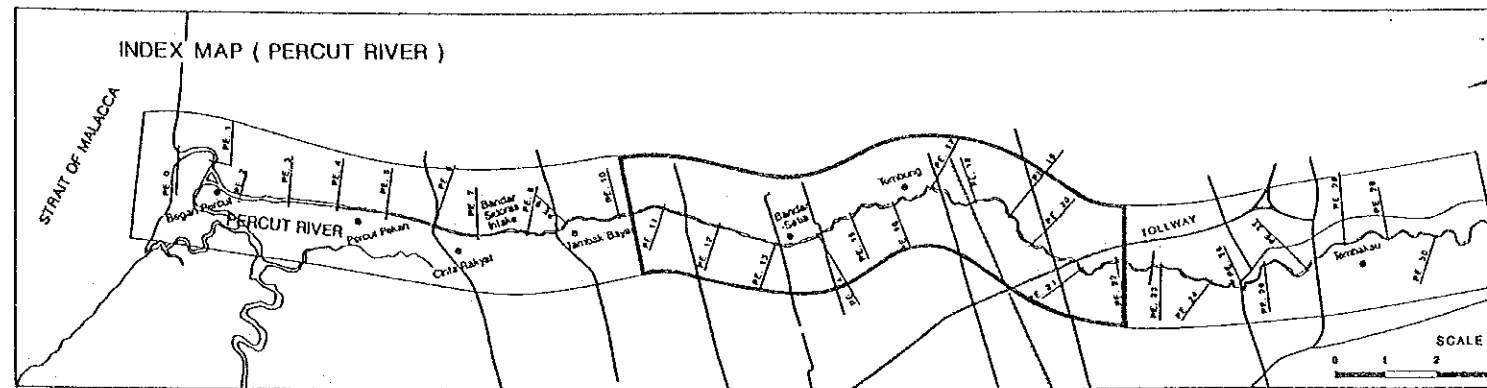
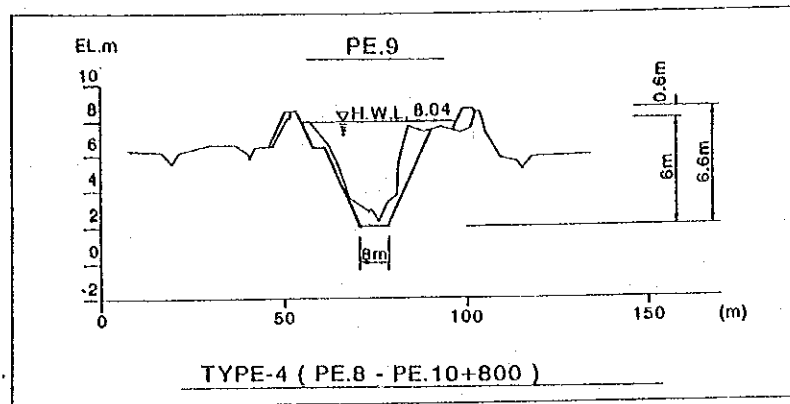

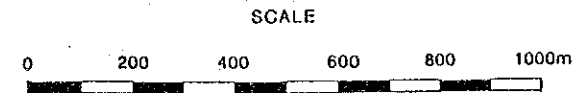
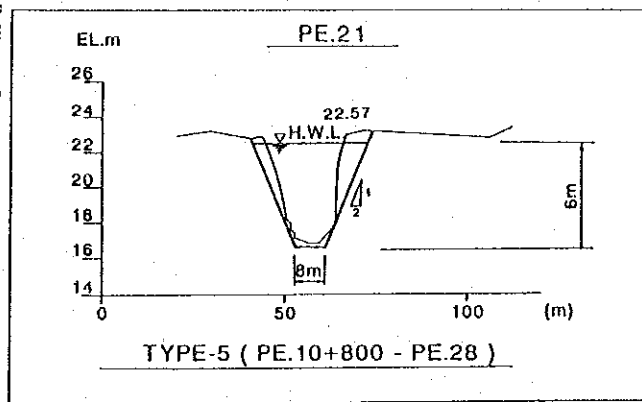
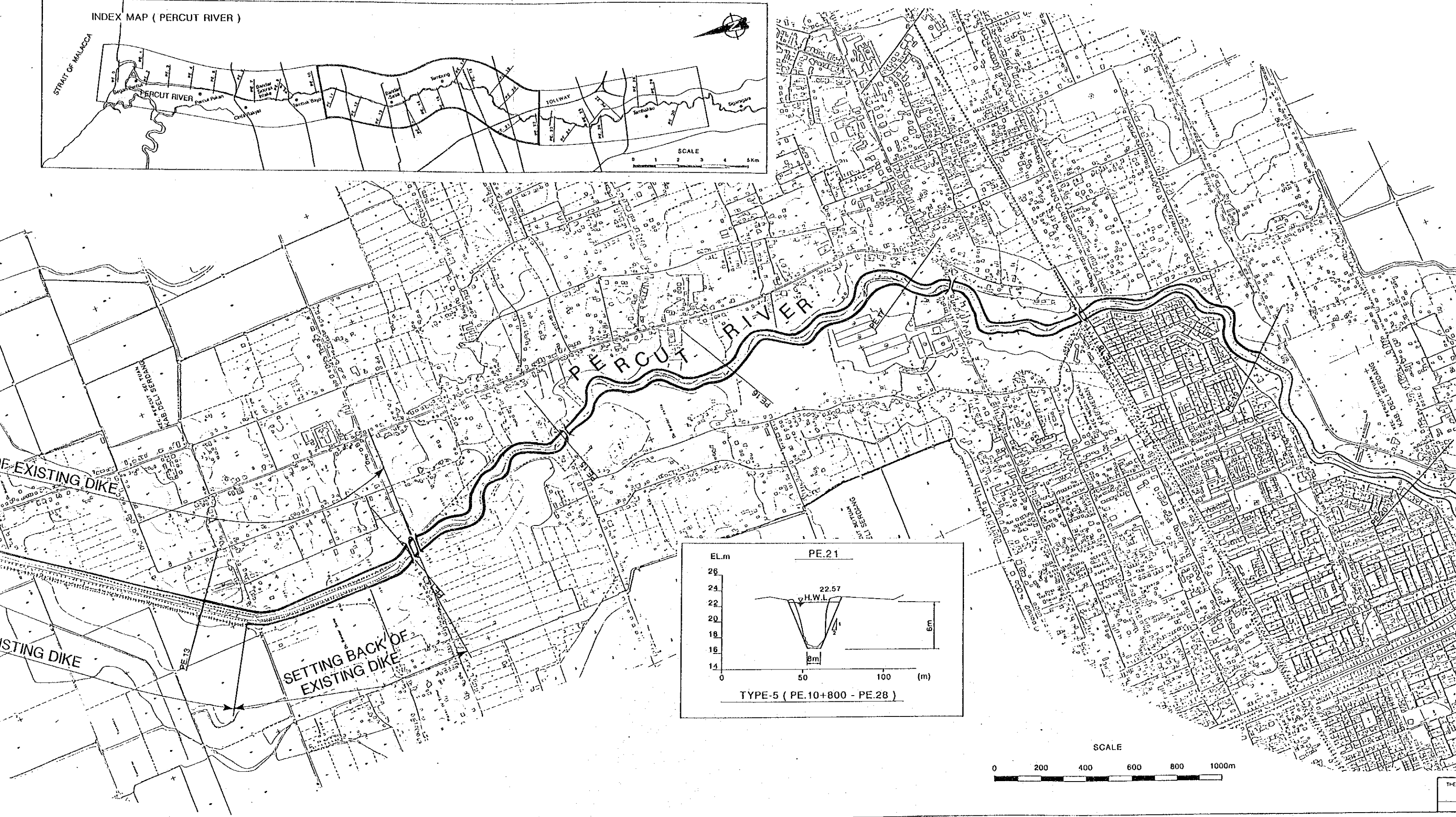
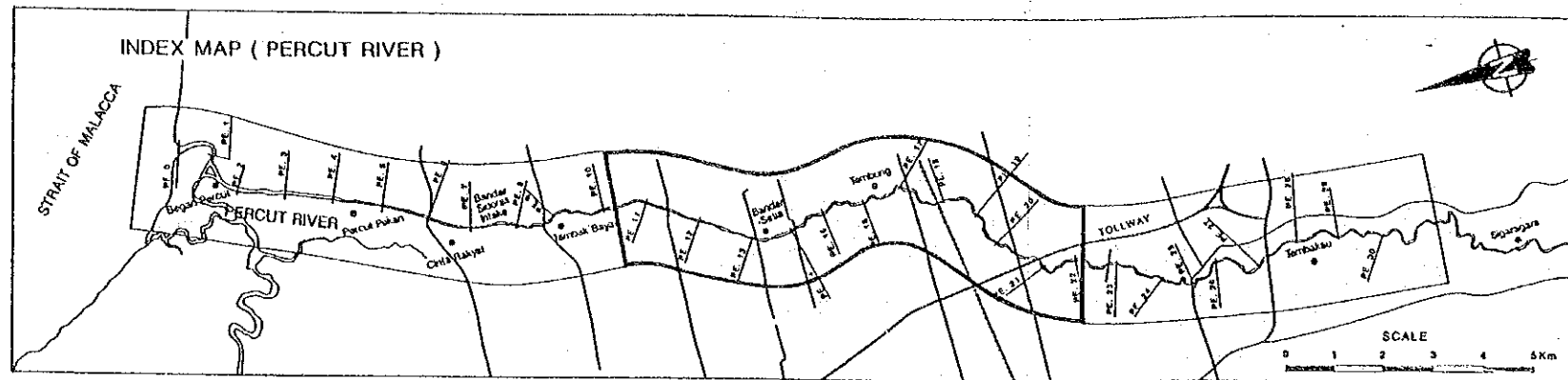

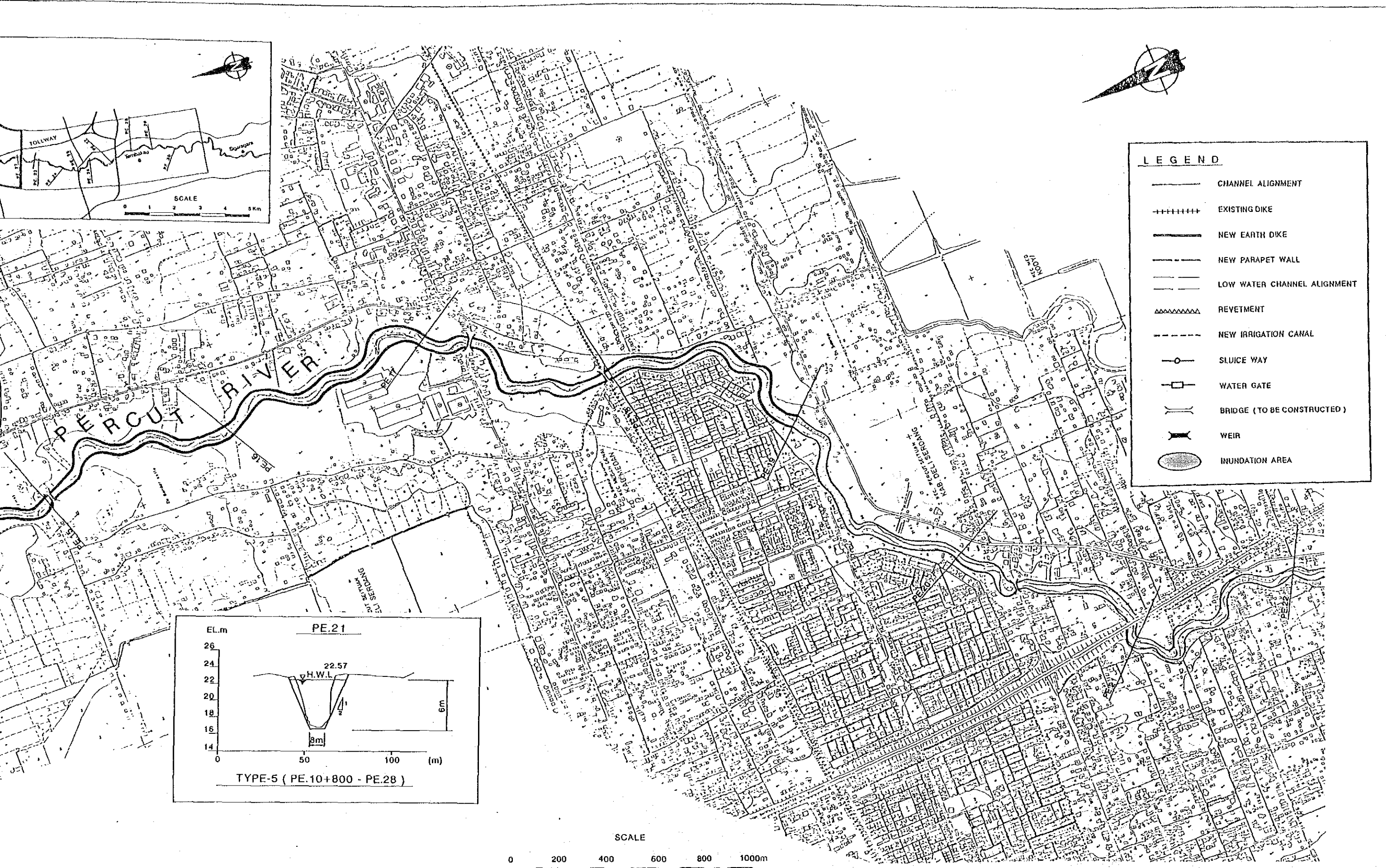

LEGEND	
	CHANNEL ALIGNMENT
	EXISTING DIKE
	NEW EARTH DIKE
	NEW PARAPET WALL
	LOW WATER CHANNEL ALIGNMENT
	REVETMENT
	NEW IRRIGATION CANAL
	SLUICE WAY
	WATER GATE
	BRIDGE (TO BE CONSTRUCTED)
	WEIR
	INUNDATION AREA

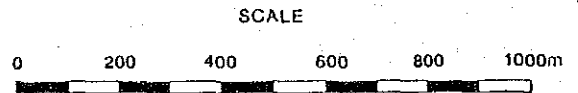
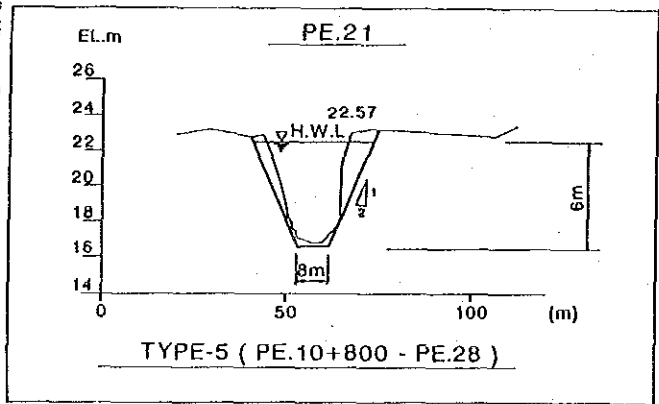

THE STUDY ON BELAWAN-PADANG INTEGRATED RIVER BASIN DEVELOPMENT
 IN THE REPUBLIC OF INDONESIA
 JAPAN INTERNATIONAL COOPERATION AGENCY

ALIGNMENT AND TYPICAL CROSS SECTION OF
 PROPOSED PERCUT RIVER IMPROVEMENT
 WORKS
 Fig. 3-8 (2/3)