

AFTERCARE STUDY
ON
TRAFFIC OPERATION PLAN FOR ROADS
IN
THE KINGDOM OF THAILAND
FINAL REPORT
(DRAWINGS)

NOVEMBER 1991

JAPAN INTERNATIONAL COOPERATION AGENCY

L122
71
88F

ESF
ORIO
91-088

JICA LIBRARY



1095902(1)

23306

AFTERCARE STUDY
ON
TRAFFIC OPERATION PLAN FOR ROADS
IN
THE KINGDOM OF THAILAND

FINAL REPORT
(DRAWINGS)

NOVEMBER 1991

JAPAN INTERNATIONAL COOPERATION AGENCY

国際協力事業団

23306

LOCATION MAP

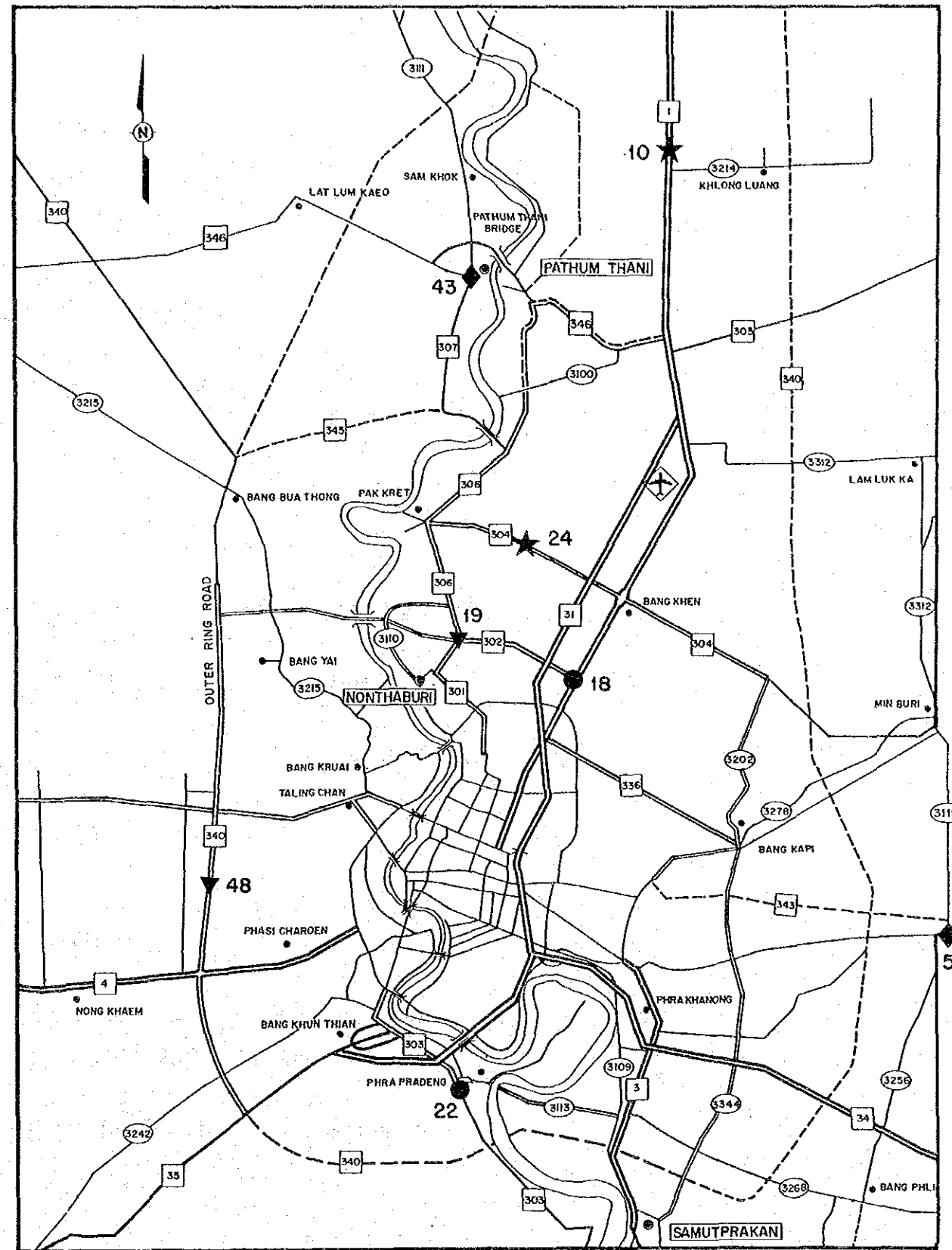
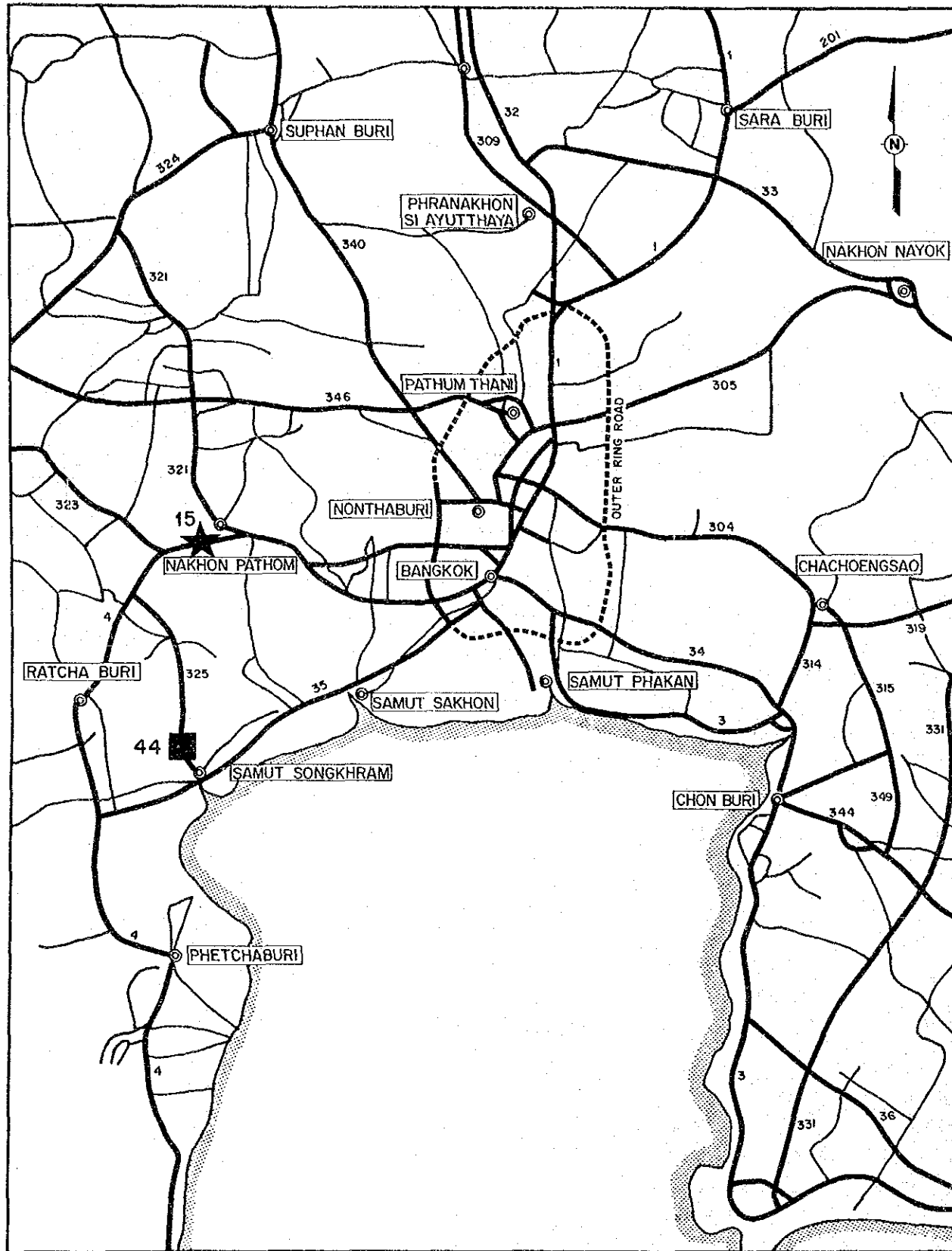

- LEGEND:**
- | | |
|--|---|
| ■ IMPROVEMENT OF ROADWAY SECTION | ▼ GRADE SEPARATION |
| ● IMPROVEMENT OF SIGNALIZED INTERSECTION | ★ IMPROVEMENT OF INTERSECTION AND MEDIAN OPENINGS |
| ◆ SIGNALIZATION AND CHANELIZATION | |

INDEX

IMPROVEMENT PLAN

			SHEET NO.
S-10	ENT. A.I.T.	ROADWAY SECTION / R 1	1
S-15	SANAMCHAN PALACE	SMALL INTERSECTION / R 4	2
S-18	KASET SAT	INTERSECTION / R 302 / R 1	3
S-19	KHAE RAI	INTERSECTION / R 302 / R 306	4
S-22	PRAPADAENG	INTERSECTION / R 303 / R 3104	5
S-24	KHLONG PRAPA	INTERSECTION / R 304 / BMA. RD.	6
S-43	PATHUM WILAI	INTERSECTION/R307./R3035/R3111	7
S-44	DAMNOEN SADUAK	ROADWAY SECTION / R 325	8
S-48	BANG WAEK	INTERSECTION / R 340 / BMA. RD. SHORT TERM PLAN	9
S-48	BANG WAEK	INTERSECTION/ R 340 / BMA. RD. LONG TERM PLAN	10
S-52	ONN NUCH-3119	INTERSECTION / R 3119 / BMA. RD.	11

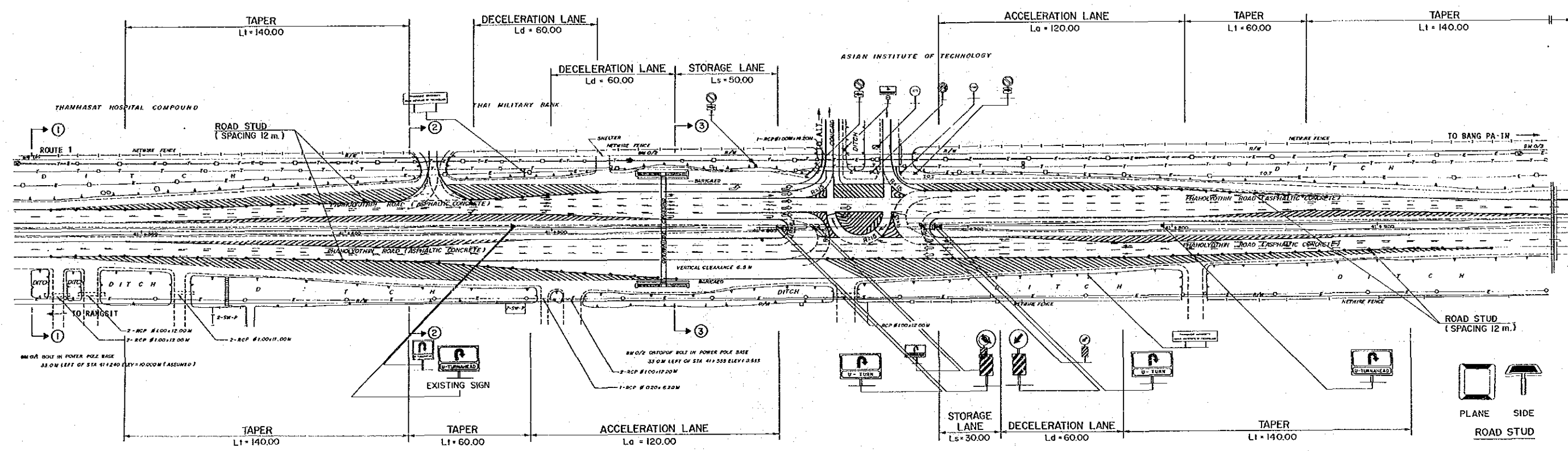

- LEGEND:**
- TELEPHONE LINE W/P Pole
 - POWER LINE W/P Pole
 - WATER PIPING W/ STOPPER
 - STORAGE W/ JUNCTION
 - CABLE CONDUIT W/ MANHOLE
 - LAMP POST
 - TRAFFIC LIGHT SIGNAL
 - TRAFFIC SIGNAL
 - BUS STOP
 - TAXI STAND
 - TRAFFIC SIGN
 - TELEPHONE RELAY BOX
 - POST BOX
 - TRAFFIC CONTROL SWITCH BOARD
 - TELEPHONE KIOSK
 - UTILITY BOX
 - BUS SHELTER
 - POWER POLE W/ LAMP
 - PARKING METER
 - ①-①-① 3 STOREY CONCRETE FRAME ENG W/ 1ST 5000 CONCRETION
 - ②-②-② 2 STOREY WOOD FRAME, POOR CONCRETION

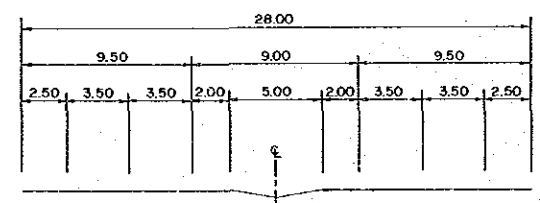

SECTION ①-①

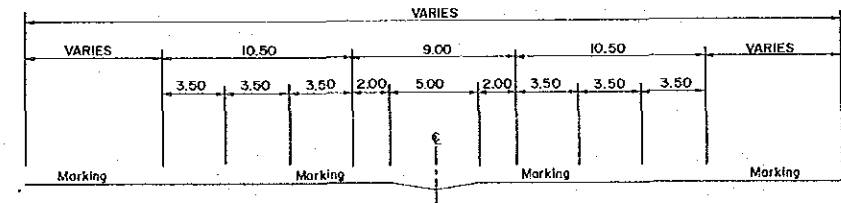

SECTION ②-②

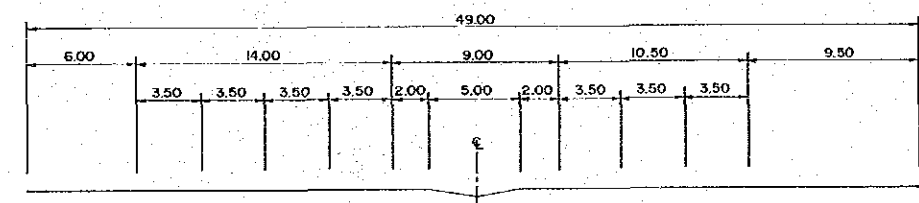

SECTION ③-③



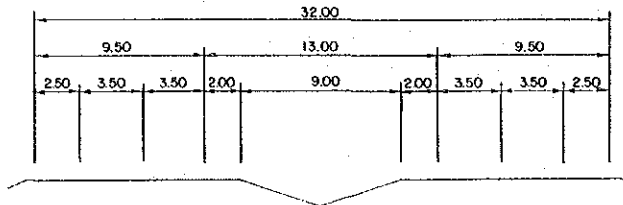

SECTION ①-①

SIGNAL PHASE		
10	20	30

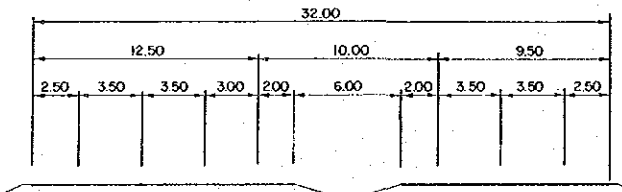
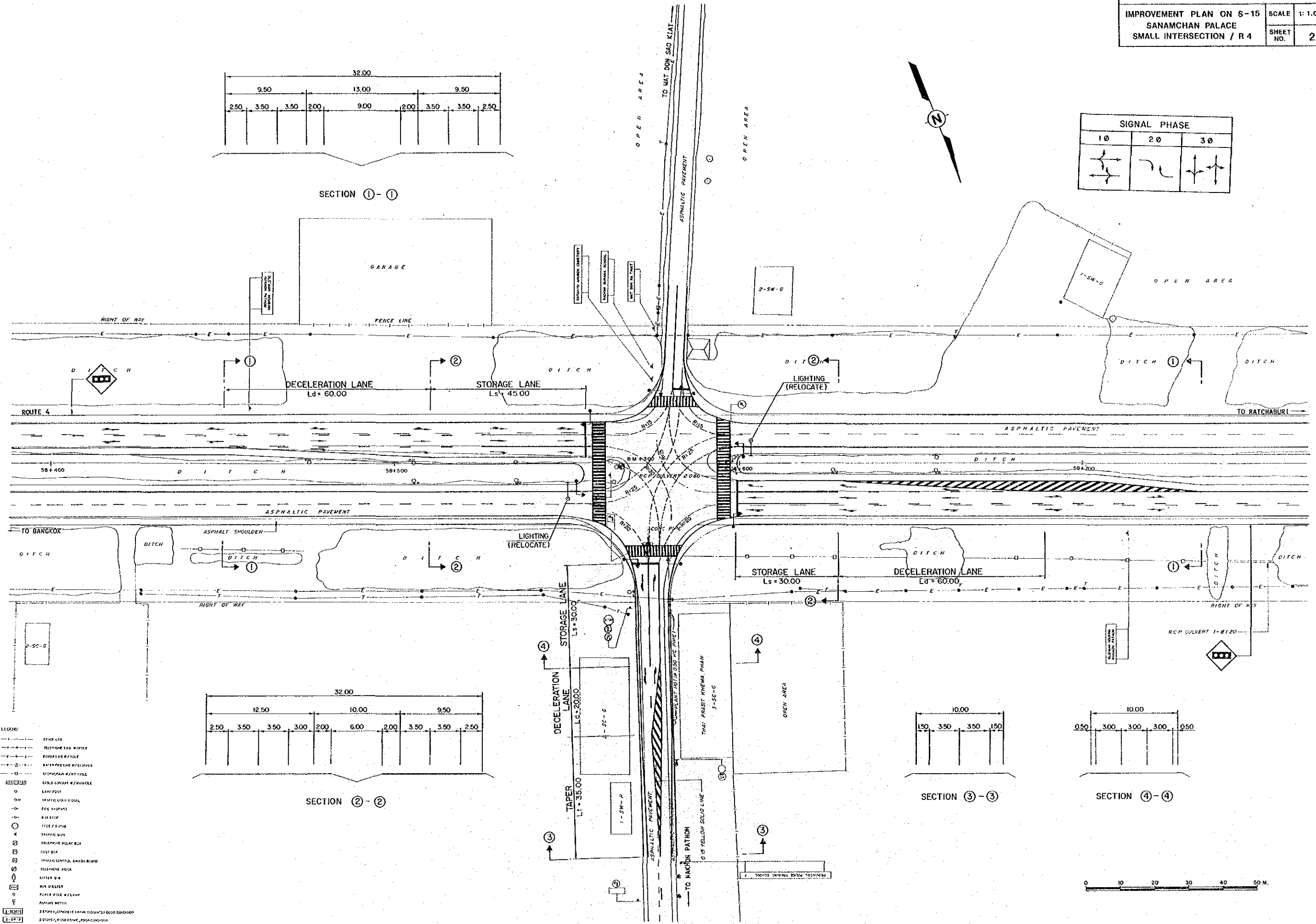

SECTION ②-②

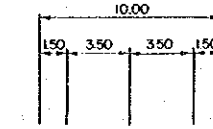

SECTION ③-③

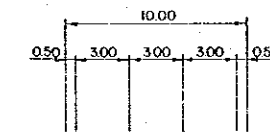

SECTION ④-④

- LEGEND:
- FENCE LINE
 - TELEPHONE LINE W/POLE
 - POWER LINE W/POLE
 - WATER PIPE LINE W/SIGNECK
 - SLOPE LINE W/PERCENT
 - GROUND CONTOUR W/MAJOR
 - LAMP POST
 - TRAFFIC LIGHT SIGNAL
 - FIRE SIGNAL
 - BUS STOP
 - TREE P/STUB
 - TRAFFIC SIGN
 - TELEPHONE RELAY BOX
 - TEST BOX
 - TRAFFIC CONTROL SIGNAL BOARD
 - TELEPHONE POLE
 - LITTER BIN
 - BOX CULVERT
 - POWER POLE W/LAMP
 - WATER METER
 - ①-① 330MM CONCRETE (1:1.5) 150MM DIA. 3000mm
 - ②-② 210MM CONCRETE (1:1.5) 150MM DIA. 3000mm



SIGNAL PHASE		
10	20	30

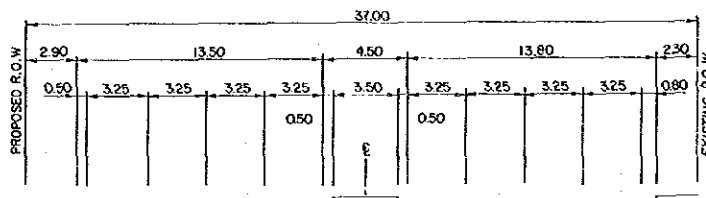

SECTION ① - ①

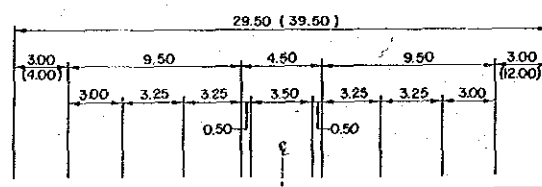
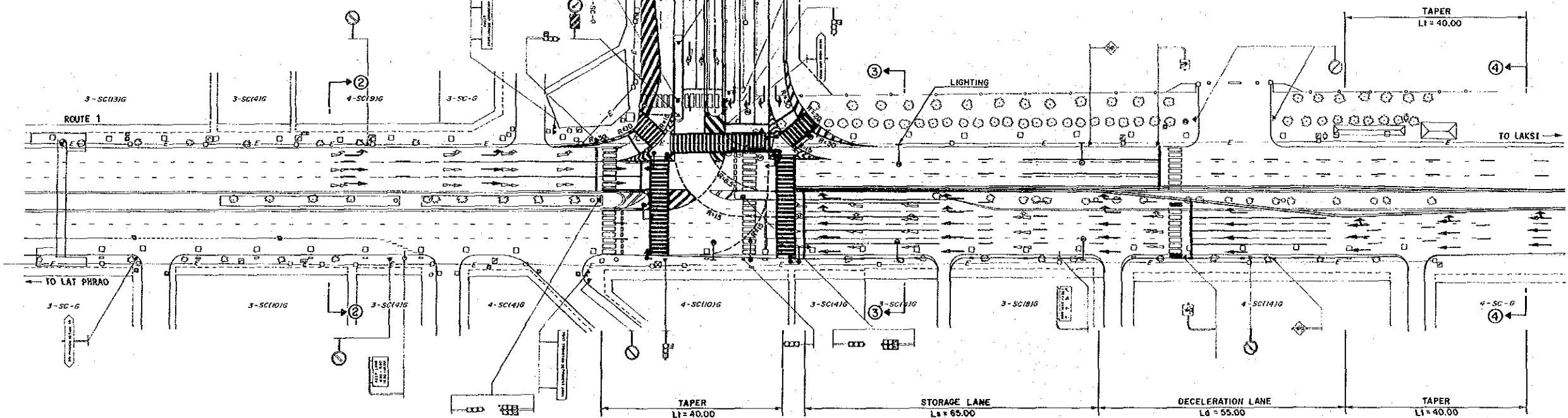

SECTION ② - ②
(SECTION ④ - ④)

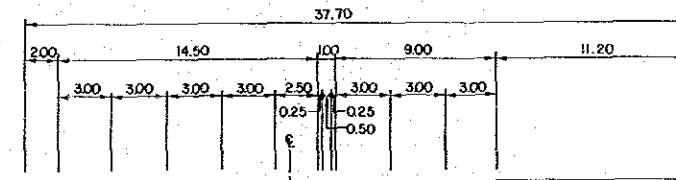

SECTION ③ - ③



- LEGEND:
- FENCE LINE
 - TELEPHONE LINE W/ POLE
 - POWER LINE W/ POLE
 - WATER PIPE LINE W/ VALVE
 - SLOPE GRADE W/ VALVE
 - GENE CONDUIT W/ VALVE
 - LAMP POST
 - TRAFFIC LIGHT SIGNAL
 - FIRE HYDRANT
 - BUS STOP
 - TIDE / LEVEL
 - TRAFFIC SIGN
 - TELEPHONE SIGNAL BOX
 - POST BOX
 - TRAFFIC CONTROL SIGNAL BOARD
 - TELEPHONE KIOSK
 - METER BOX
 - BUS SHELTER
 - POWER POLE W/ LAMP
 - PAINTED MARK
 - 3.5% SLOPE (ADJUSTED) LANE TO SATISFY GOOD CONDITION
 - 3.5% SLOPE (ADJUSTED) ROAD CONDITION

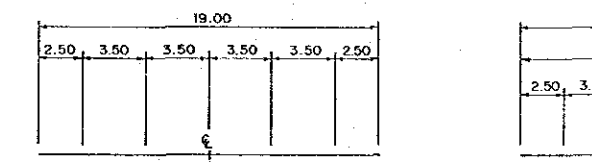
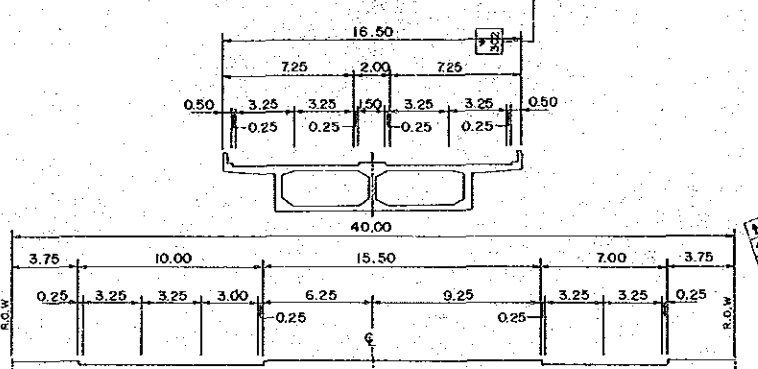
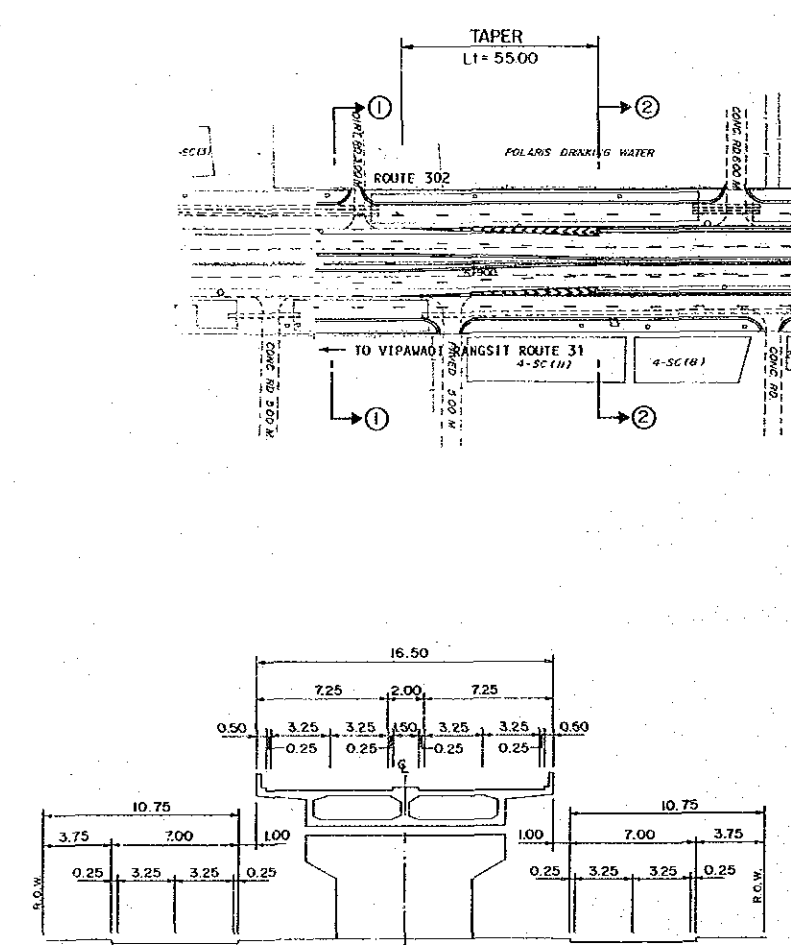
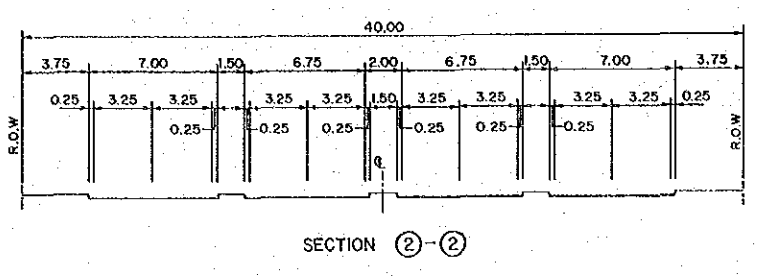
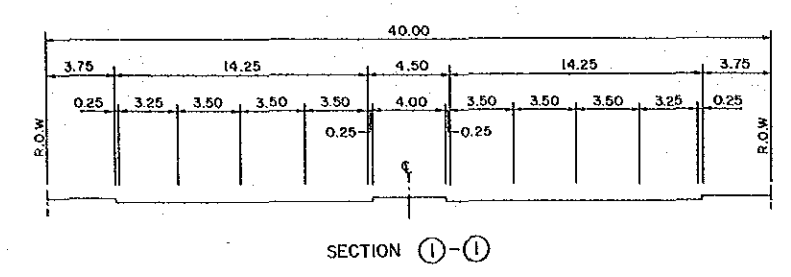

- LEGEND:
- EDGE LINE
 - TELEPHONE LINE W/POLE
 - POWER LINE W/POLE
 - WATER TOWER LINE W/POLE
 - TELEVISION LINE W/POLE
 - FIRE HYDRANT W/POLE
 - LAMP POST
 - TRAFFIC SIGNAL
 - FIRE ALARM
 - BUS STOP
 - TREE / SIGN
 - TRAFFIC SIGN
 - TELEPHONE RELAY BOX
 - POST BOX
 - TRAFFIC CONTROL LIGHT SIGNAL
 - TELEPHONE KIOSK
 - LETTER BOX
 - BUS STOP
 - POWER POLE W/FLUOR
 - POWER POLE
 - 3.5% CONCRETE PAVEMENT (2.5% SLOPE CONDITION)
 - 1.5% ASPHALT PAVEMENT (1.5% SLOPE CONDITION)

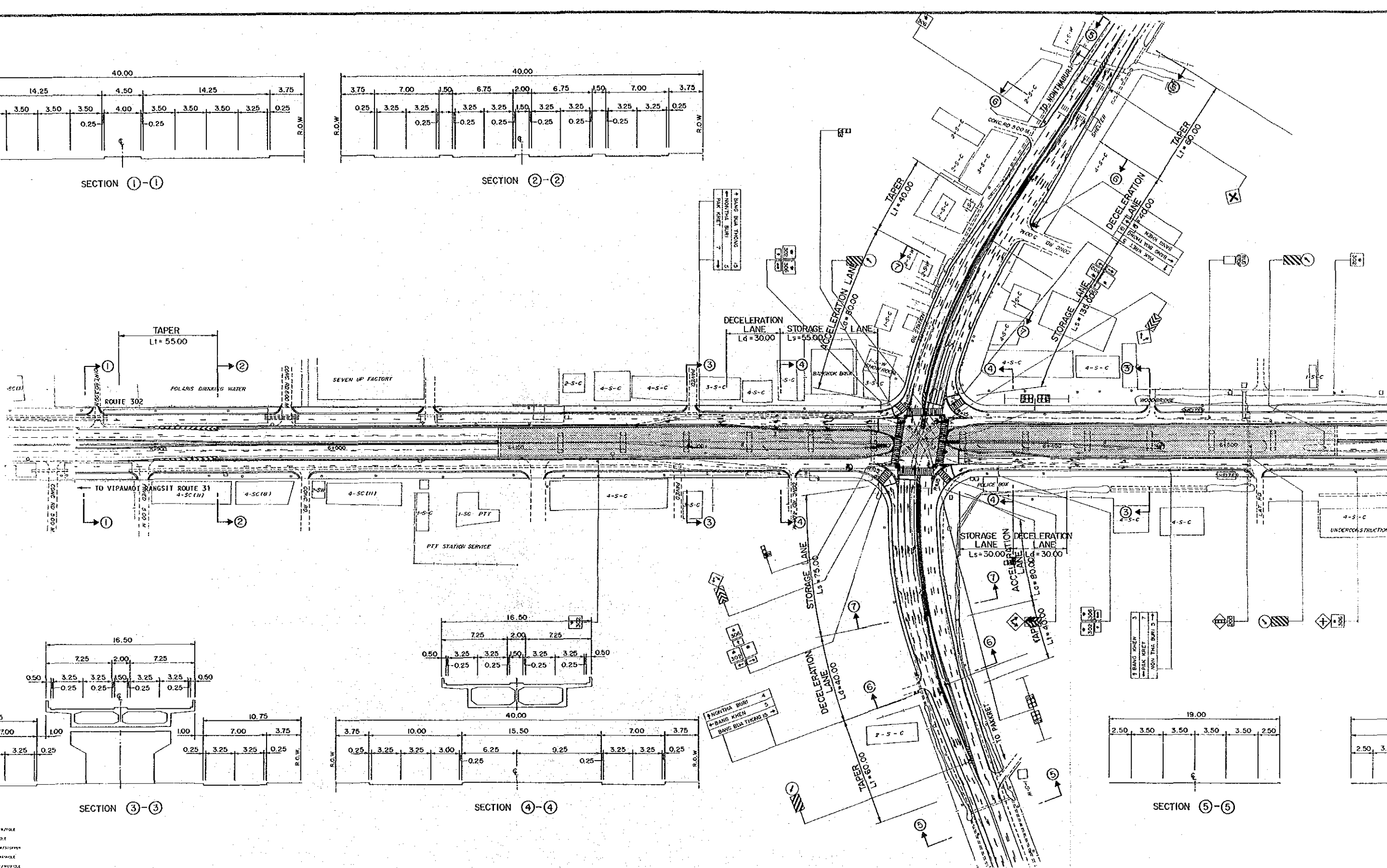
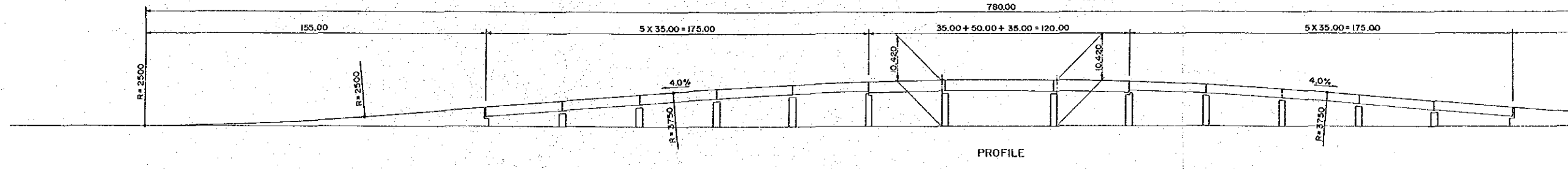

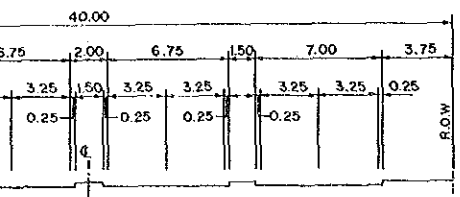

SECTION 2-2

SIGNAL PHASE		
10	20	30

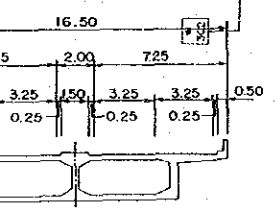

SECTION 4-4

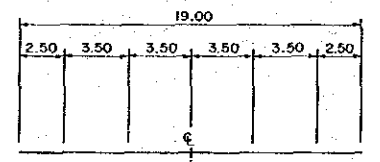

SECTION 5-5

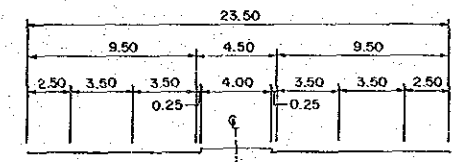

SECTION 6-6

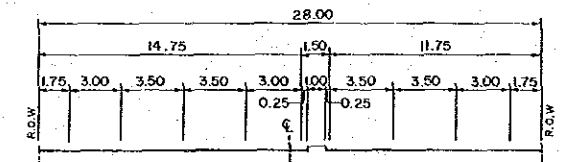

SECTION 7-7

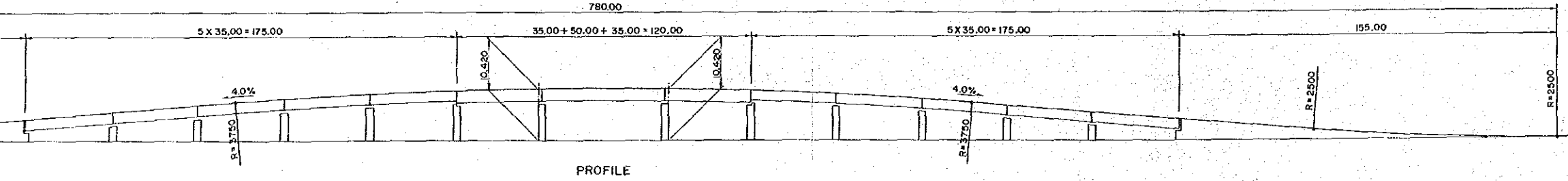

PROFILE



- LEGEND:
- FENCE LINE
 - TELEPHONE LINE W/POLE
 - POWER LINE W/POLE
 - WATER PIPE LINE W/STOPPER
 - SEWER MAIN W/STOPPER
 - CABLE DUCT W/STOPPER
 - LAMP POST
 - TRAFFIC LIGHT SIGNAL
 - FIRE HYDRANT
 - BUS STOP
 - TANK / BIVOUAC
 - TRAFFIC SIGN
 - TELEPHONE RELAY BOX
 - POST BOX
 - TRAFFIC CONTROL SIGNAL BOARD
 - TELEPHONE BOOTH
 - LIGHT BOX
 - BUS SHELTER
 - POWER POLE W/FLAW
 - PAWING BESELER
 - 1 STONE, CONCRETE FRAME (LID WITH) 60/90 CM DIAMETER
 - 2 STONE, WOOD FRAME, POOR CONDITION

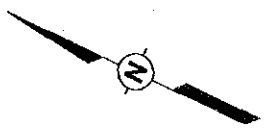

SIGNAL PHASE		
10	20	30

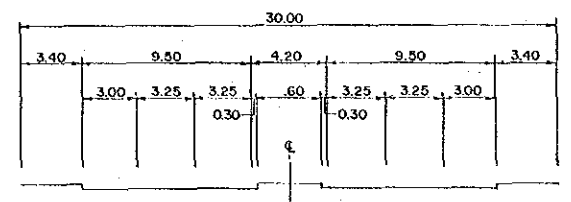

SECTION ④ - ④

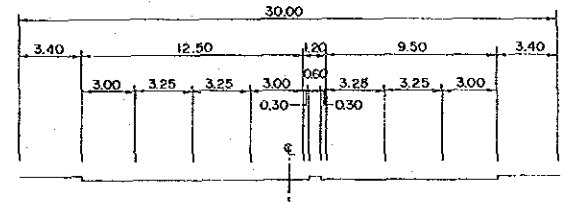

SECTION ⑤ - ⑤

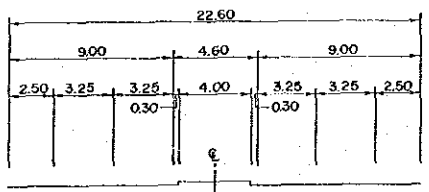
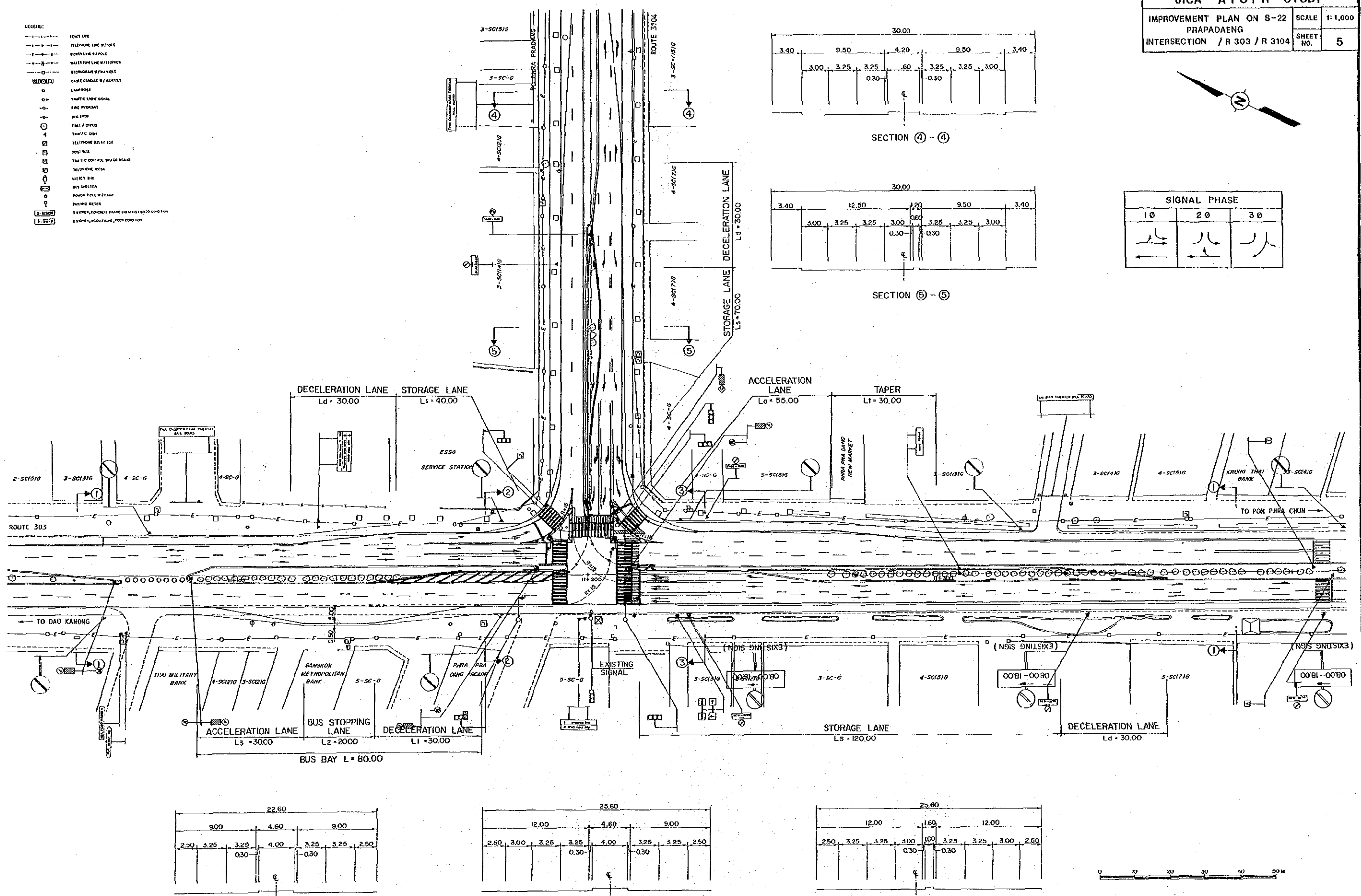

SECTION ① - ①

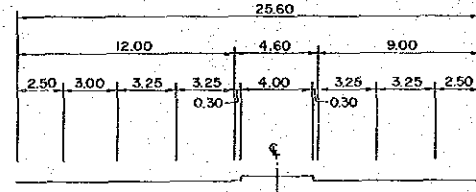

SECTION ② - ②

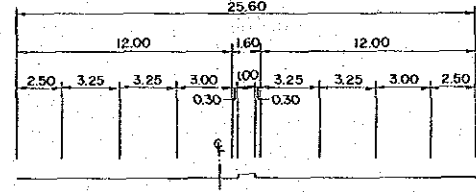

SECTION ③ - ③



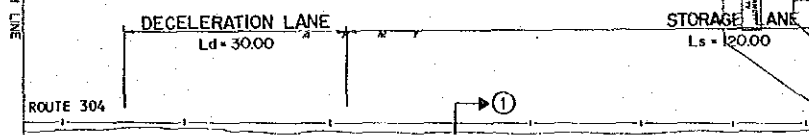
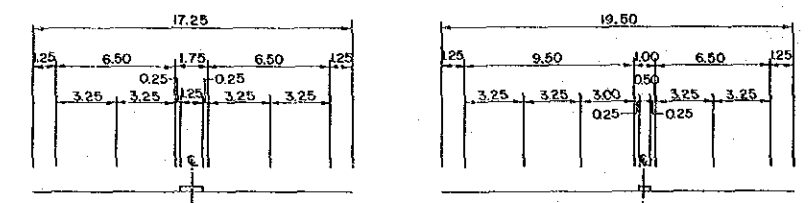

SIGNAL PHASE		
1 Ø	2 Ø	3 Ø

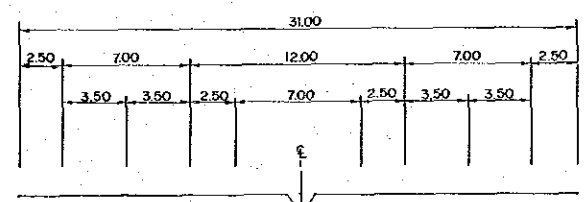
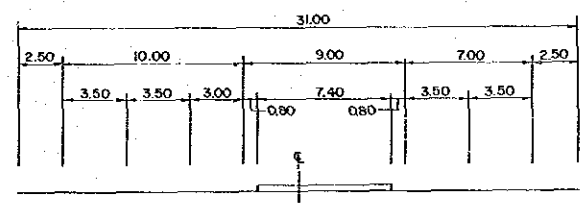
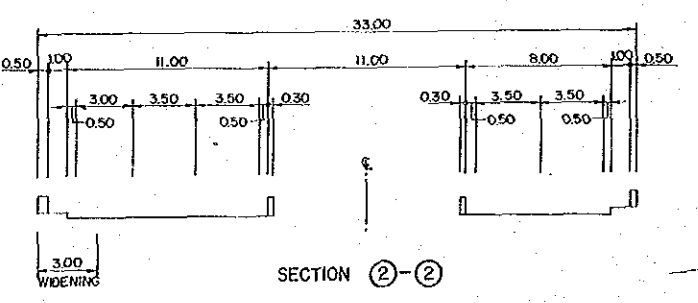
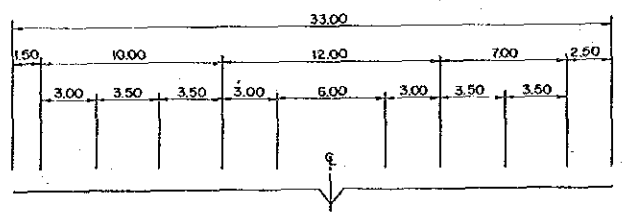

- LEGEND:
- LINE LINE
 - TELEPHONE LINE W/POLE
 - POWER LINE W/POLE
 - WATER PIPE LINE W/STOPPER
 - SLOPE/GRAN W/HANDRAIL
 - CABLE CONDUIT W/HANDRAIL
 - CAMP POST
 - TRAFFIC LIGHT SIGNAL
 - FIRE HYDRANT
 - BUS STOP
 - TREE / BUSH
 - TRAFFIC SIGN
 - TELEPHONE RELAY STA
 - POST BOX
 - TRAFFIC CONTROL SIGNAL BOARD
 - TELEPHONE WORK
 - METEOR SIGN
 - BUS WHEELER
 - POWER POLE W/LAMP
 - PARKING METER
 - STONE, CONCRETE FRAME AND LIGHTS ROAD BOUNDARY
 - STONE, CONCRETE FRAME, POLE POSITION



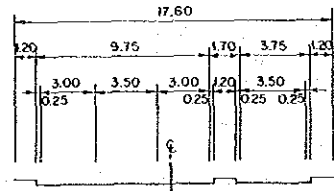
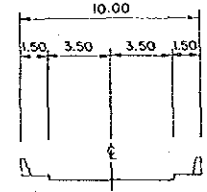
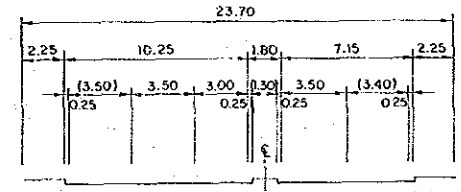
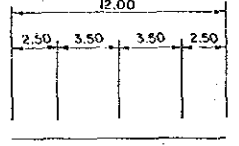
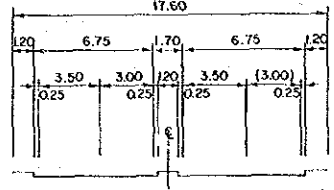
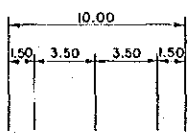
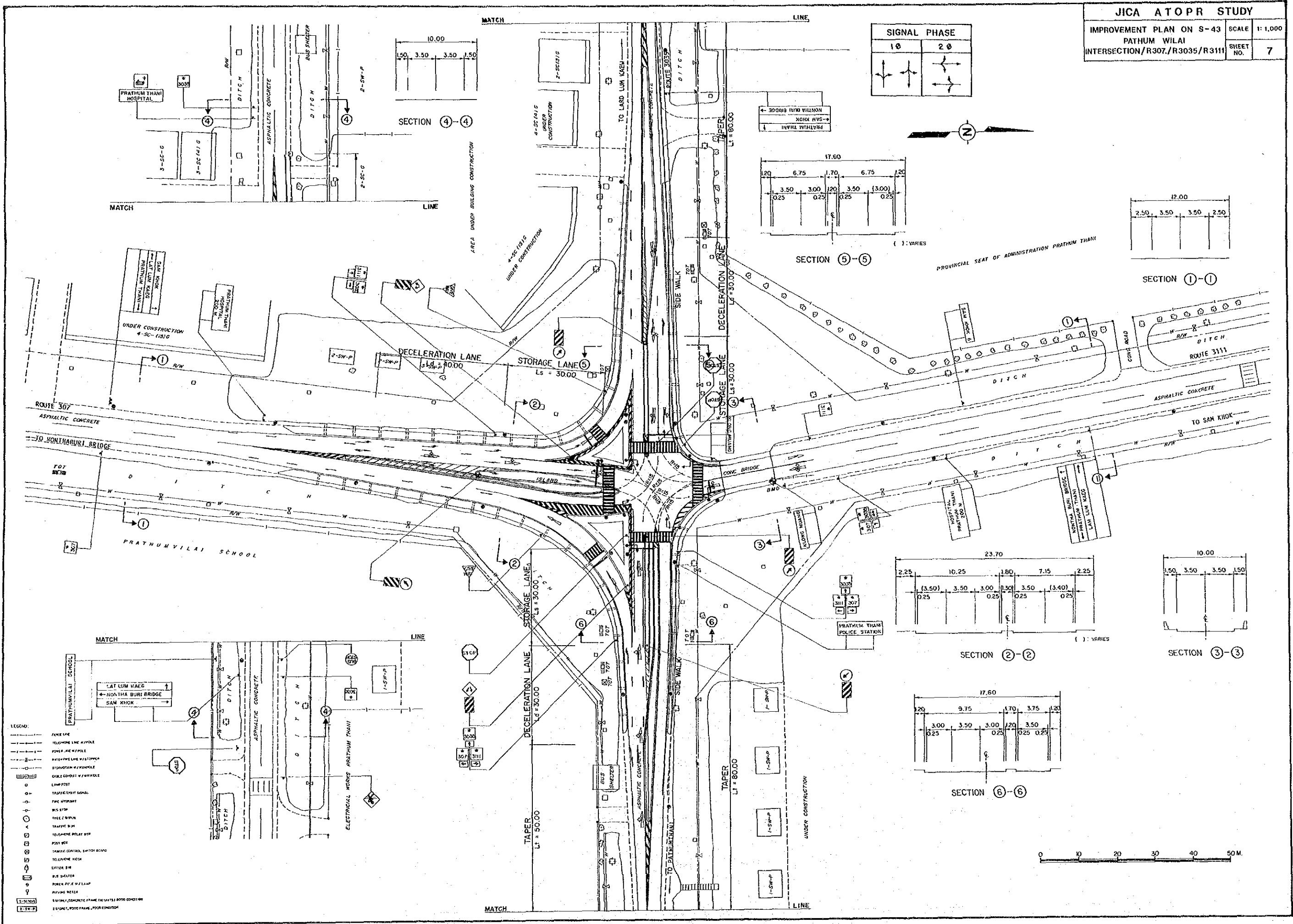
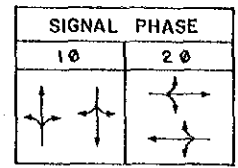

- LEGEND:
- FENCE LINE
 - TELEPHONE LINE
 - POWER LINE
 - WATER SUPPLY LINE
 - STORM DRAIN
 - CABLE CONDUIT
 - LAMP POST
 - TRAFFIC LIGHT SIGNAL
 - FIRE HYDRANT
 - BUS STOP
 - TREE SYMBOL
 - TRAFFIC SIGN
 - TELEPHONE RELAY BOX
 - POST BOX
 - TRAFFIC CONTROL SWITCH BOARD
 - TELEPHONE BOOTH
 - UTILITY POLE
 - BUS SHELTER
 - POWER POLE WITH LAMP
 - PAVING NETTING
 - CONCRETE FRAME FOR UTILITY BOX CONDITION
 - CONCRETE FRAME FOR UTILITY BOX CONDITION



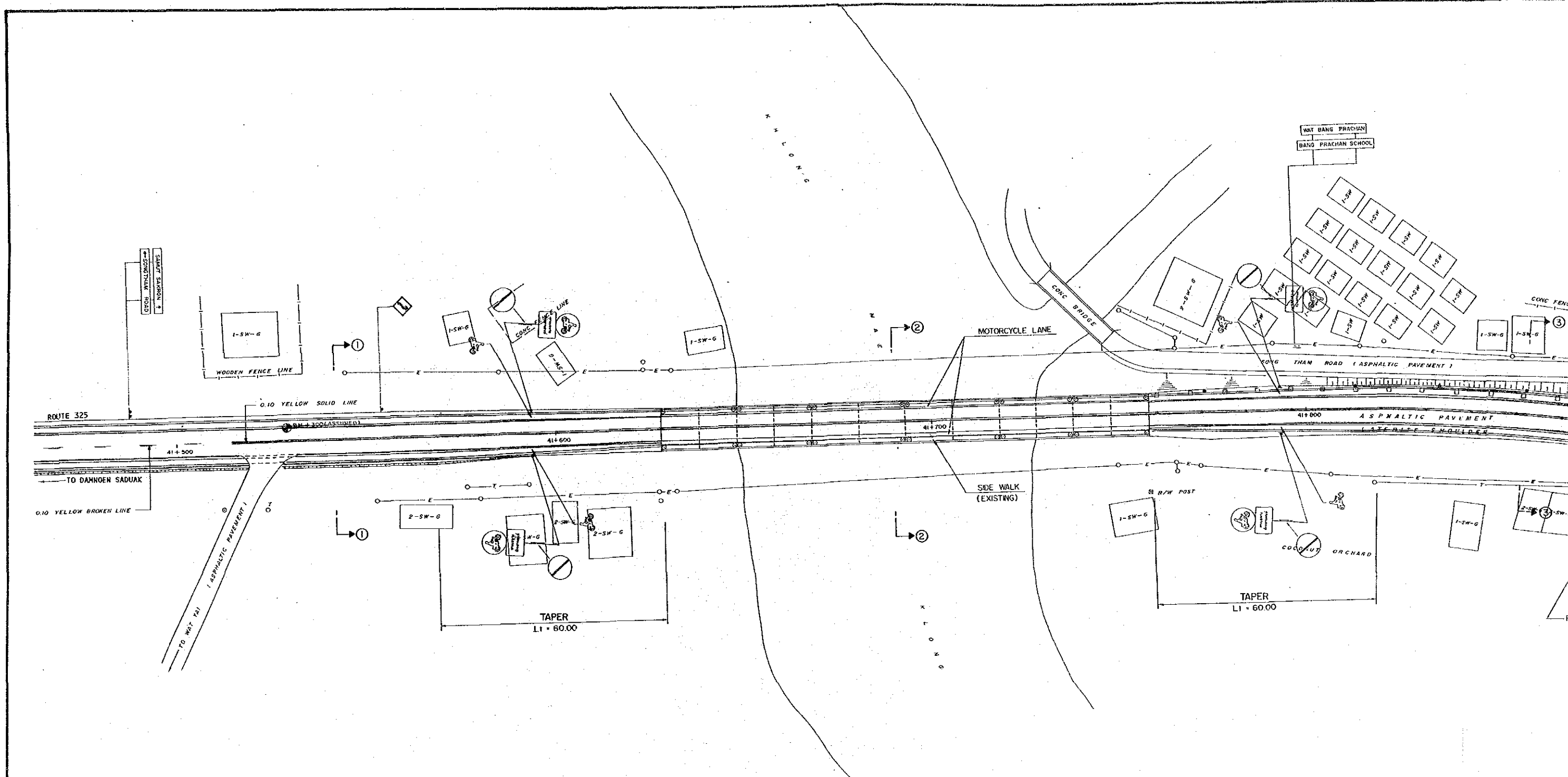

- LEGEND:
- TELEPHONE LINE W/ POLE
 - POWER LINE W/ POLE
 - WATER PIPE LINE W/ STOPVAL
 - SLOUGH/RAIN W/ MANHOLE
 - CABLE CONDUIT W/ MANHOLE
 - LAMP POST
 - TRAFFIC LIGHT SIGNAL
 - FIRE HYDRANT
 - BUS STOP
 - TRUCK / BUSES
 - TRAFFIC SIGN
 - TELEPHONE RELAY BOX
 - POLE BOX
 - TRAFFIC CONTROL BOARD
 - TELEPHONE BOX
 - WATER BIN
 - BUS WHEELER
 - POWER POLE W/ LAMP
 - WATER METER
 - 3.10 METER, CONCRETE FRAME (G. W/ 1000 DIMENSION)
 - 3.10 METER, WOOD FRAME, POOR CONDITION

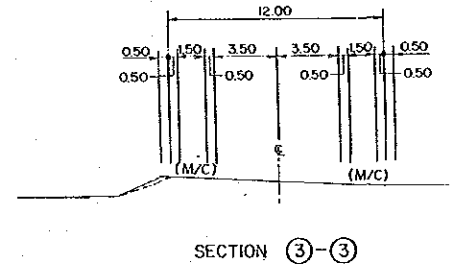
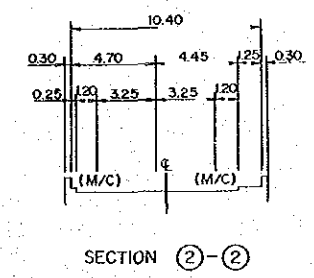
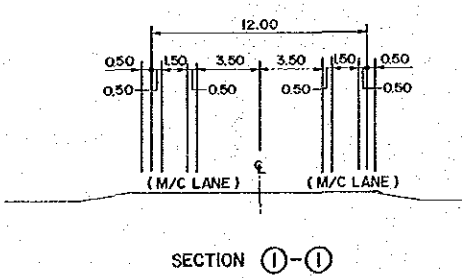

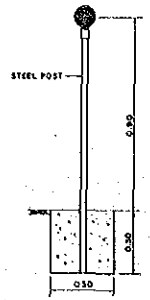

DELINEATOR INSTALLATION

DELINEATORS MOUNTED ON STEEL POLE
 (SPACING 15~40 m.)

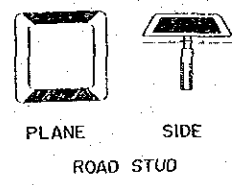
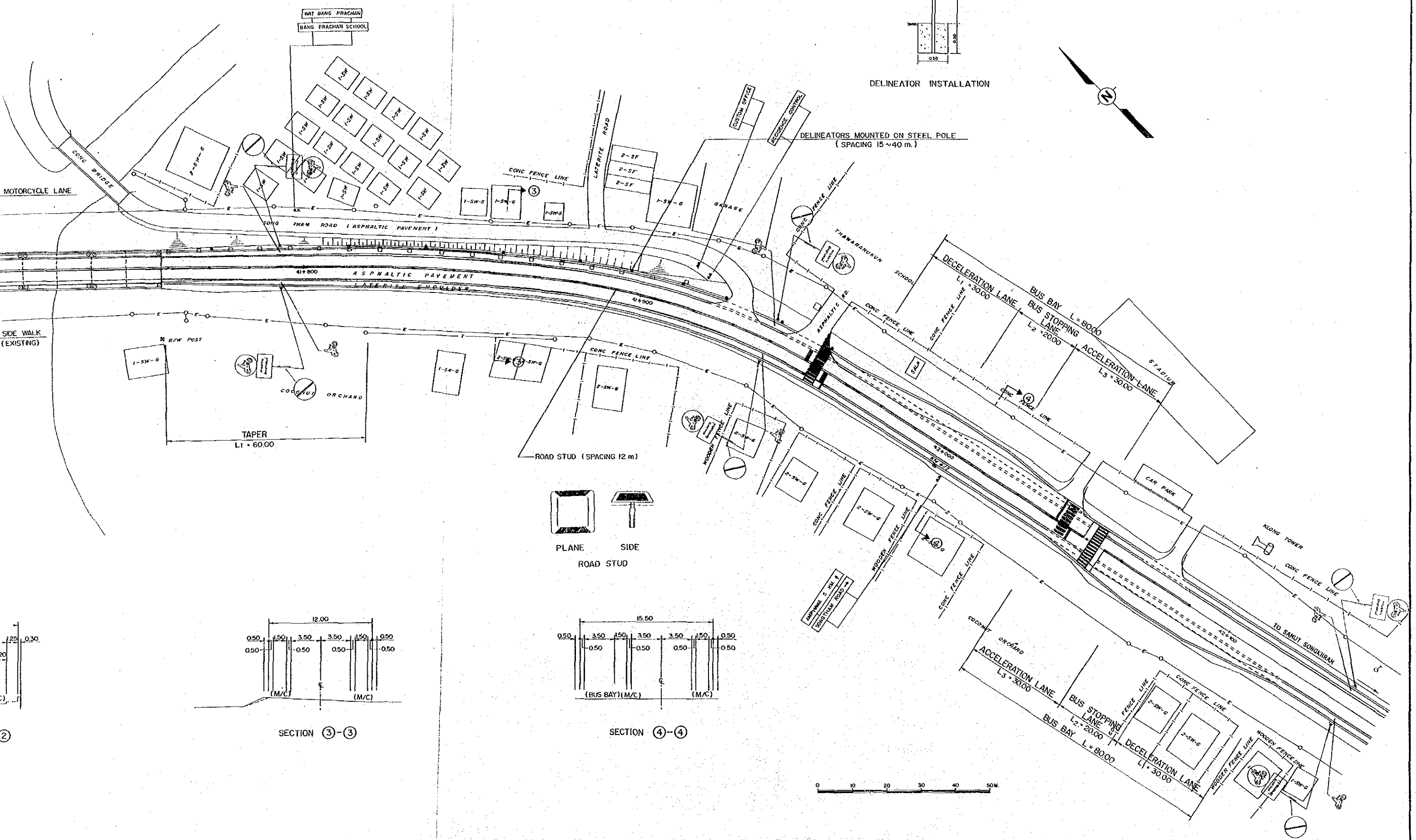
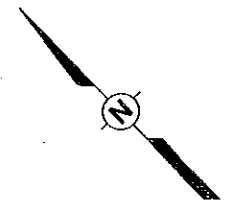

ROAD STUD

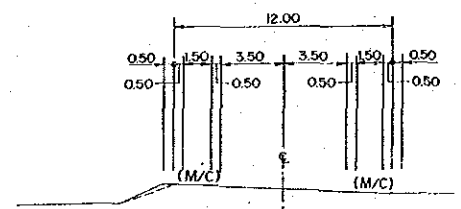

SECTION 3-3

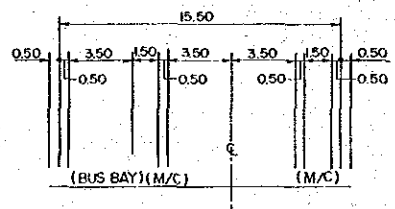

SECTION 4-4

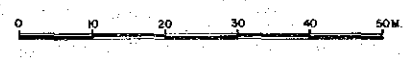

SIGNAL PHASE		
10	20	30

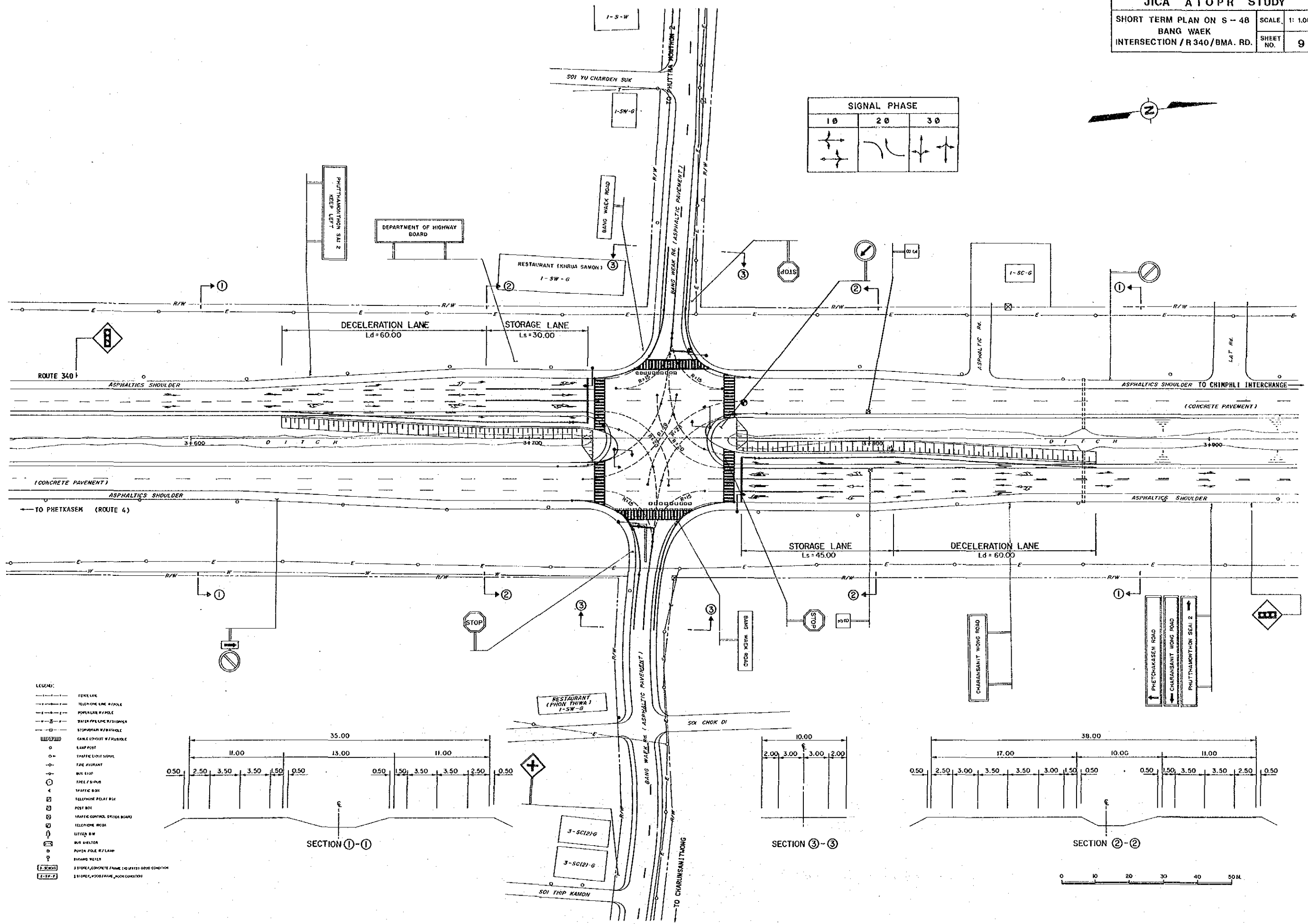

- LEGEND:
- FENCE LINE
 - TELEPHONE LINE # POLE
 - POWER LINE # POLE
 - WATER PIPING # PIPE
 - STOP SIGN # SIGNPOST
 - CANAL # COAST # W/VAULT
 - LAMP POST
 - TRAFFIC LIGHT SIGNAL
 - FIRE HYDRANT
 - BUS STOP
 - TREE # SIGN
 - TRAFFIC SIGN
 - TELEPHONE RELAY BOX
 - POST BOX
 - TRAFFIC CONTROL SIGNAL BOARD
 - TELEPHONE BOOTH
 - LITTER BIN
 - BUS SHELTER
 - POWER POLE # LAMP
 - DRAINAGE WATER
 - 1-3 ROAD
 - 1-3 SHOULDER, CONCRETE PAVEMENT (TO BE SET) GOOD CONDITION
 - 1-3 SHOULDER, ASPHALTIC PAVEMENT, POOR CONDITION

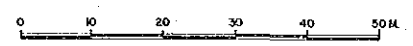
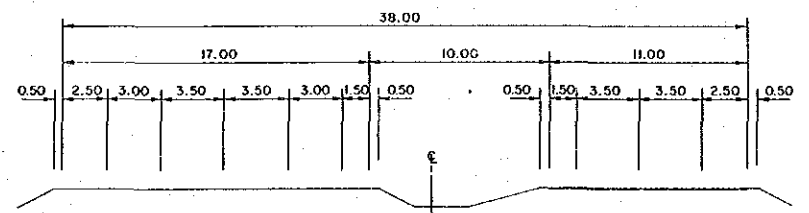
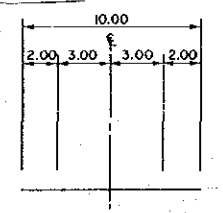
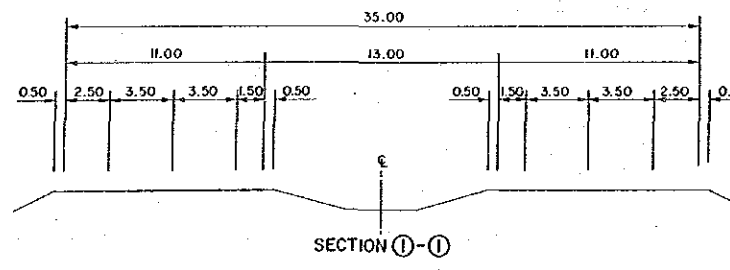

- LEGEND
- — — — — FENCE LINE
 - — — — — TELEPHONE LINE W/ POLE
 - — — — — POWERLINE W/ POLE
 - — — — — WATER MAINLINE W/ STOPPER
 - — — — — TELEPHONE W/ MAINLINE
 - — — — — CABLE CORDON W/ FAHSA POLE
 - LAMP POST
 - TRAFFIC LIGHT SIGNAL
 - EYE W/ SIGNAL
 - BUS STOP
 - FACE / SIGN
 - TRAFFIC SIGN
 - TELEPHONE SIGNAL BOX
 - POST BOX
 - TRAFFIC CONTROL SWITCH BOARD
 - TELEPHONE BOOTH
 - LETTER SIGN
 - BUS SHELTER
 - POWER POLE W/ LAMP
 - PAVING BEZEL
 - ① ② ③ ④ ⑤ ⑥ ⑦ ⑧ ⑨ ⑩ ⑪ ⑫ ⑬ ⑭ ⑮ ⑯ ⑰ ⑱ ⑲ ⑳ ㉑ ㉒ ㉓ ㉔ ㉕ ㉖ ㉗ ㉘ ㉙ ㉚ ㉛ ㉜ ㉝ ㉞ ㉟ ㊱ ㊲ ㊳ ㊴ ㊵ ㊶ ㊷ ㊸ ㊹ ㊺ ㊻ ㊼ ㊽ ㊾ ㊿ 01 02 03 04 05 06 07 08 09 10 11 12 13 14 15 16 17 18 19 20 21 22 23 24 25 26 27 28 29 30 31 32 33 34 35 36 37 38 39 40 41 42 43 44 45 46 47 48 49 50 51 52 53 54 55 56 57 58 59 60 61 62 63 64 65 66 67 68 69 70 71 72 73 74 75 76 77 78 79 80 81 82 83 84 85 86 87 88 89 90 91 92 93 94 95 96 97 98 99 100
 - ① ② ③ ④ ⑤ ⑥ ⑦ ⑧ ⑨ ⑩ ⑪ ⑫ ⑬ ⑭ ⑮ ⑯ ⑰ ⑱ ⑲ ⑳ ㉑ ㉒ ㉓ ㉔ ㉕ ㉖ ㉗ ㉘ ㉙ ㉚ ㉛ ㉜ ㉝ ㉞ ㉟ ㊱ ㊲ ㊳ ㊴ ㊵ ㊶ ㊷ ㊸ ㊹ ㊺ ㊻ ㊼ ㊽ ㊾ ㊿ 01 02 03 04 05 06 07 08 09 10 11 12 13 14 15 16 17 18 19 20 21 22 23 24 25 26 27 28 29 30 31 32 33 34 35 36 37 38 39 40 41 42 43 44 45 46 47 48 49 50 51 52 53 54 55 56 57 58 59 60 61 62 63 64 65 66 67 68 69 70 71 72 73 74 75 76 77 78 79 80 81 82 83 84 85 86 87 88 89 90 91 92 93 94 95 96 97 98 99 100

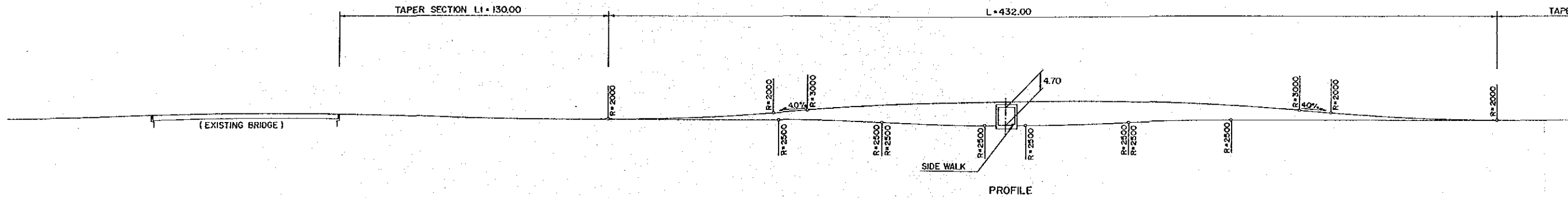
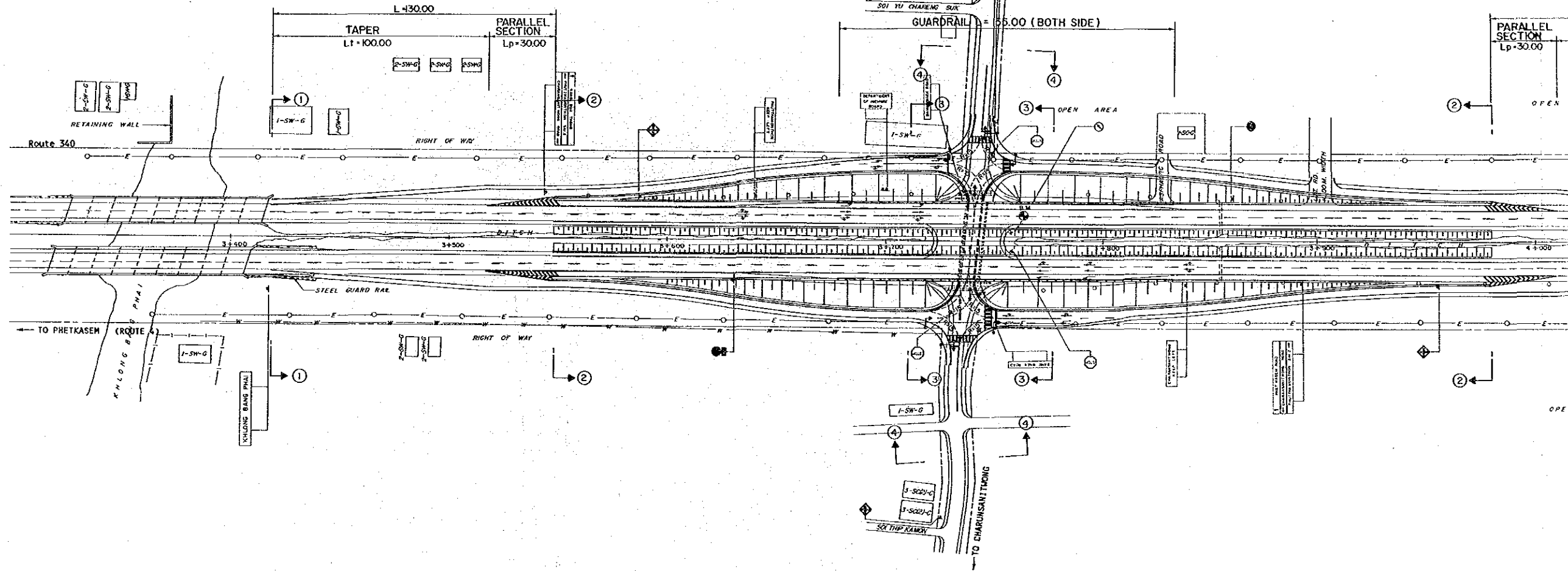
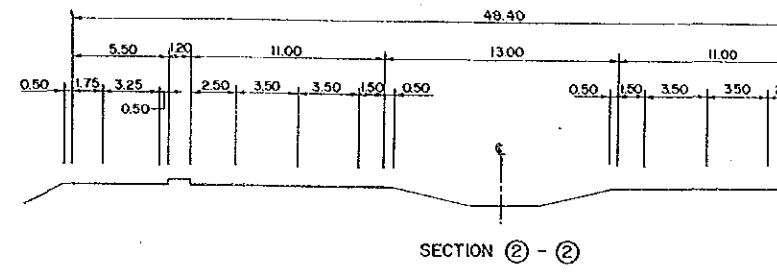
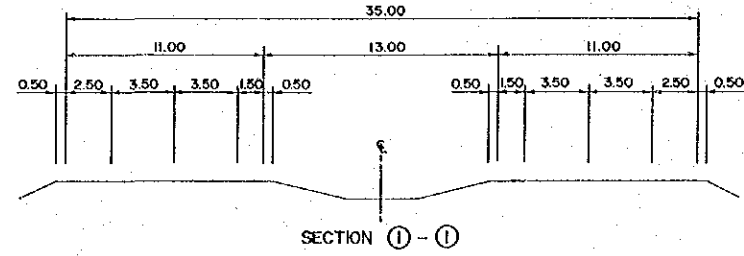

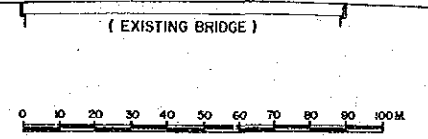
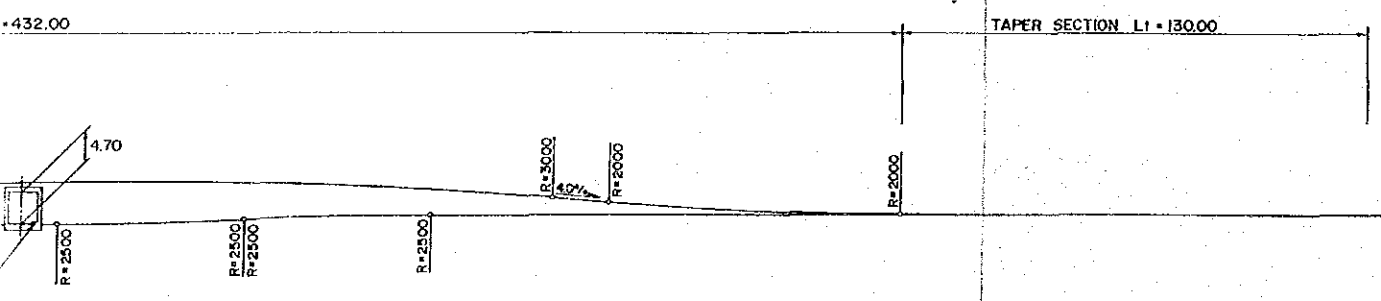
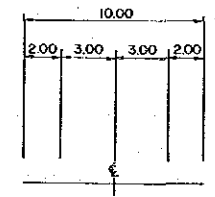
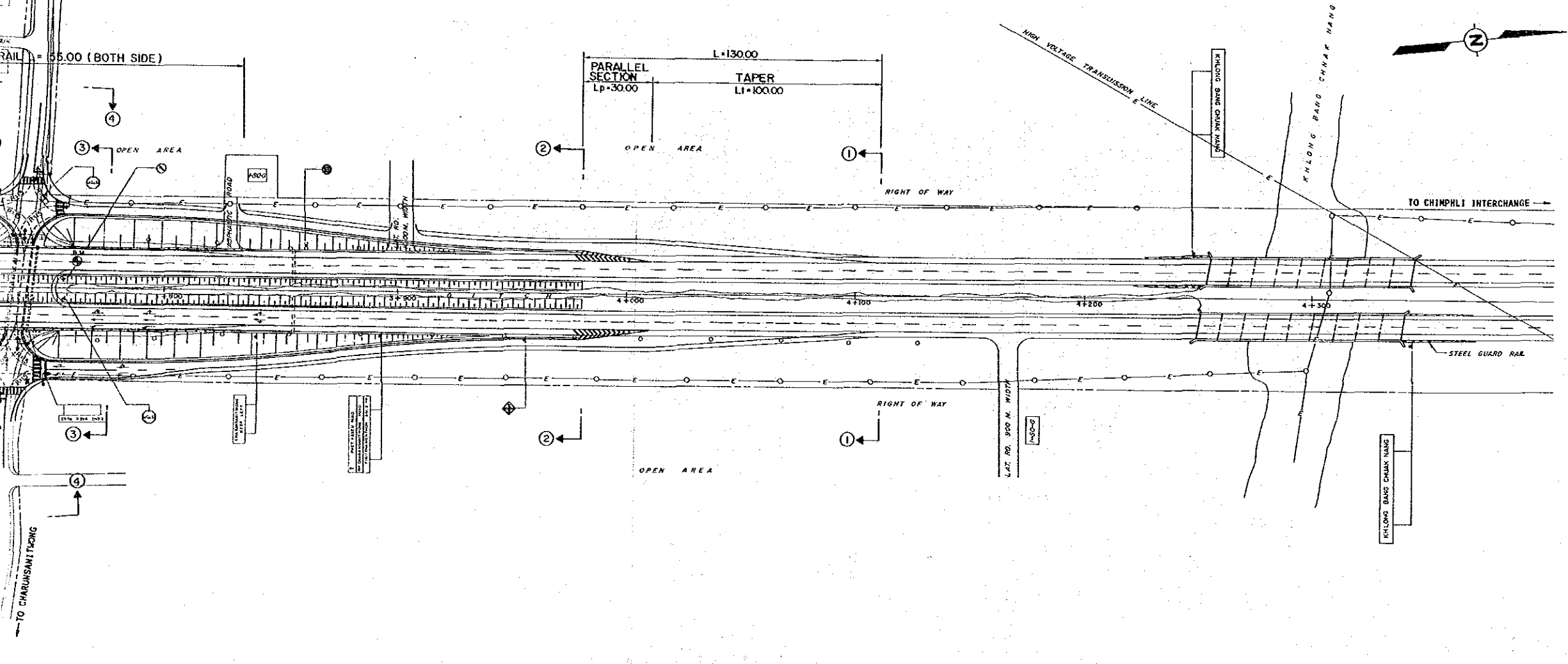
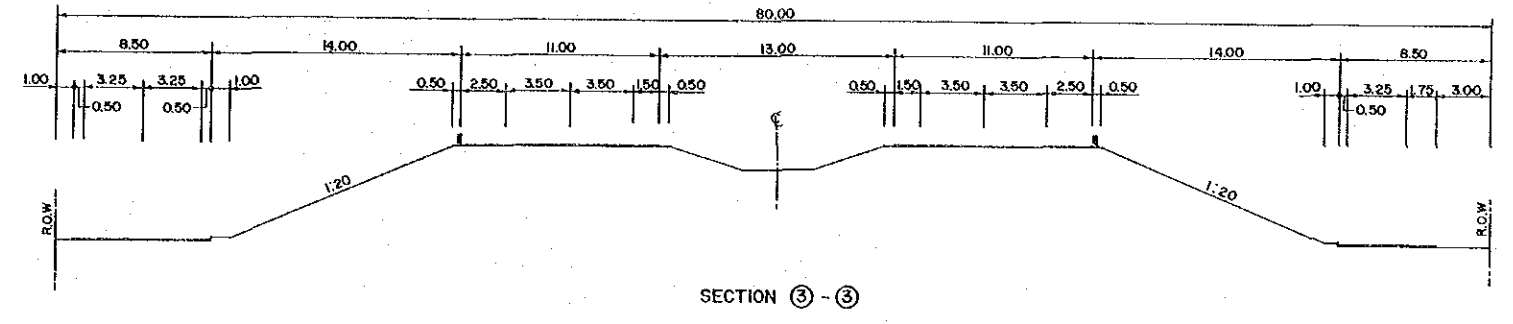
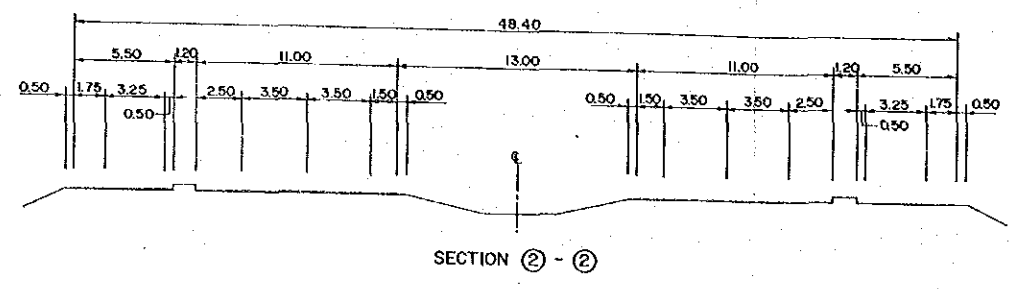

SIGNAL PHASE	
10	20

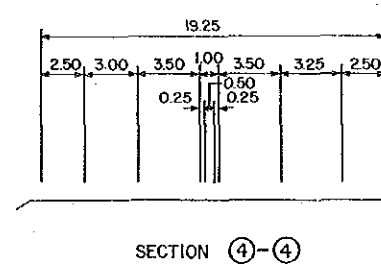
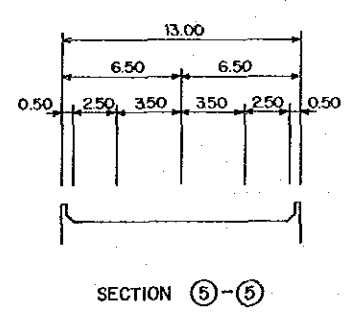
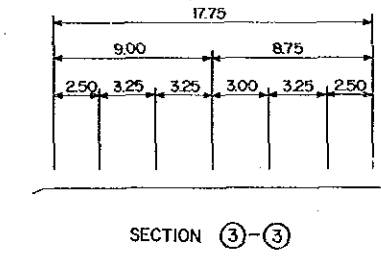
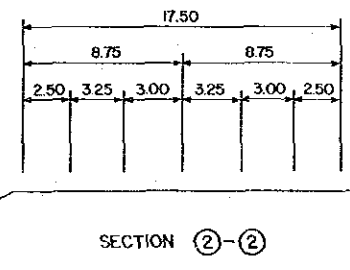
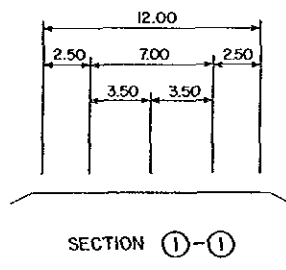
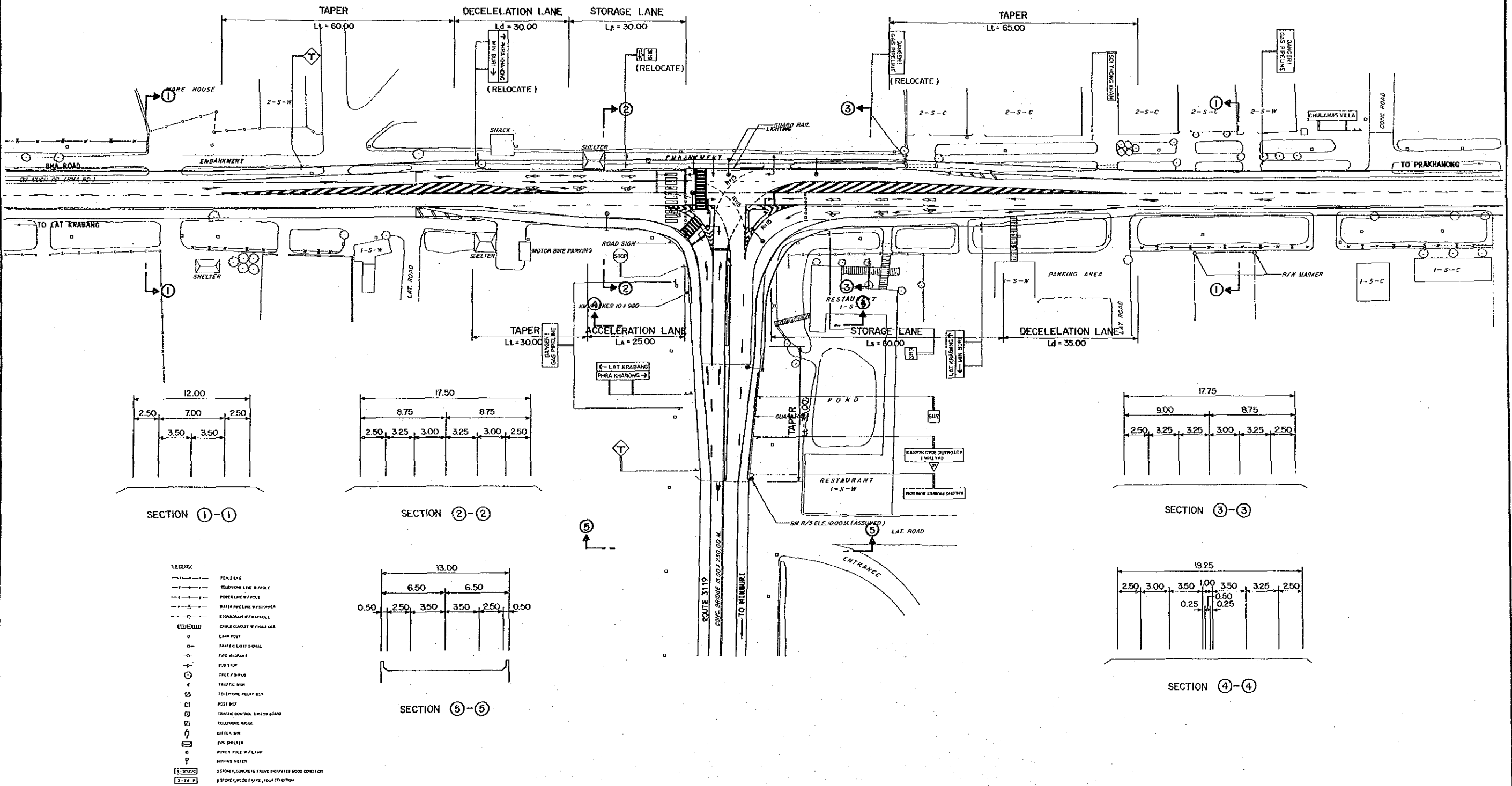
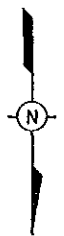

- LEGEND:**
- FENCE LINE
 - TELEPHONE LINE W/POLE
 - POWERLINE W/POLE
 - WATER PIPELINE W/VALVE
 - STOPPAGE W/WHOLE
 - CABLE CONDUIT W/MARKER
 - LAMP POST
 - TRAFFIC LIGHT SIGNAL
 - FIRE ALARM
 - BUS STOP
 - TRUCK STOP
 - TRAFFIC SIGN
 - TELEPHONE POLE BOX
 - POST BOX
 - TRAFFIC CONTROL BOARD
 - TELEPHONE BOSS
 - LITTER BIN
 - FIRE EXTINGUISHER
 - POWER POLE W/LAMP
 - BICYCLE METER
 - ① STONE, CONCRETE FRAME OR METAL ROAD CONDITION
 - ② STONE, BRICK PAVED, ROAD CONDITION

