



REPUBLIC OF KENYA
KENYA POWER COMPANY LIMITED

FEASIBILITY STUDY
ON
MAGWAGWA HYDROELECTRIC POWER
DEVELOPMENT PROJECT

FINAL REPORT
DATA BOOK (2)

OCTOBER 1991

JAPAN INTERNATIONAL COOPERATION AGENCY
NAIROBI OFFICE
P.O. BOX 60572
NAIROBI KENYA
TOKYO HEAD OFFICE
P.O. BOX 20 SHINJUKU
TOKYO JAPAN

M	P	N
G	R	(3)
91-132/00		



REPUBLIC OF KENYA
KENYA POWER COMPANY LIMITED

FEASIBILITY STUDY
ON
MAGWAGWA HYDROELECTRIC POWER
DEVELOPMENT PROJECT

FINAL REPORT

DATA BOOK (2)

JICA LIBRARY



1094426(2)

OCTOBER 1991

23069

JAPAN INTERNATIONAL COOPERATION AGENCY

NAIROBI OFFICE
P.O. BOX 50572
NAIROBI KENYA

TOKYO HEAD OFFICE
P.O. BOX 216 SHINJUKU
TOKYO JAPAN

国際協力事業団

23062

**FEASIBILITY STUDY
ON
MAGWAGWA HYDROELECTRIC POWER
DEVELOPMENT PROJECT**

DATA BOOK

Table of Contents

	<u>Page</u>
I. TOPOGRAPHY	
I.1 Topographic Map on a Scale of 1 to 1,000	
I.2 Topographic Map on a scale of 1 to 5,000	
II. GEOLOGY	
II.1 Seismic Exploration	II.1
II.2 Drilling Logs	II.18
II.3 Photos of Drilled Core	II.38
II.4 Results of Permeability Test.....	II.57
II.5 Laboratory Test	II.89
III. HYDROLOGY	
III.1 Daily Rainfall Record at Jamji Estate (9035001).....	III.1
III.2 Daily Rainfall Record at Kericho DC's (9035003)	III.43
III.3 Daily Rainfall Record at Sotik Monieri (9035013).....	III.53
III.4 Daily Rainfall Record at Reginget Estate (9035067).....	III.95
III.5 Daily Rainfall Record at Kaisuge House (9035075).....	III.109
III.6 Daily Rainfall Record at Kenwik Mission(9035079).....	III.141
III.7 Daily Discharge Record at IGD4 Station	III.166
III.8 Daily Discharge Record at 1JD3 Station	III.171
III.9 Daily Discharge Record at 1JF1 Station.....	III.191
III.10 Daily Discharge Record at 1JF7 Station.....	III.202
III.11 Daily Discharge Record at 1JF8 Station.....	III.205
III.12 Daily Discharge Record at 1JG1 Station	III.209
III.13 Daily Discharge Record at 1JG2 Station	III.254
III.14 Daily Discharge Record at 1JG3 Station	III.273

DATA BOOK I.
TOPOGRAPHY

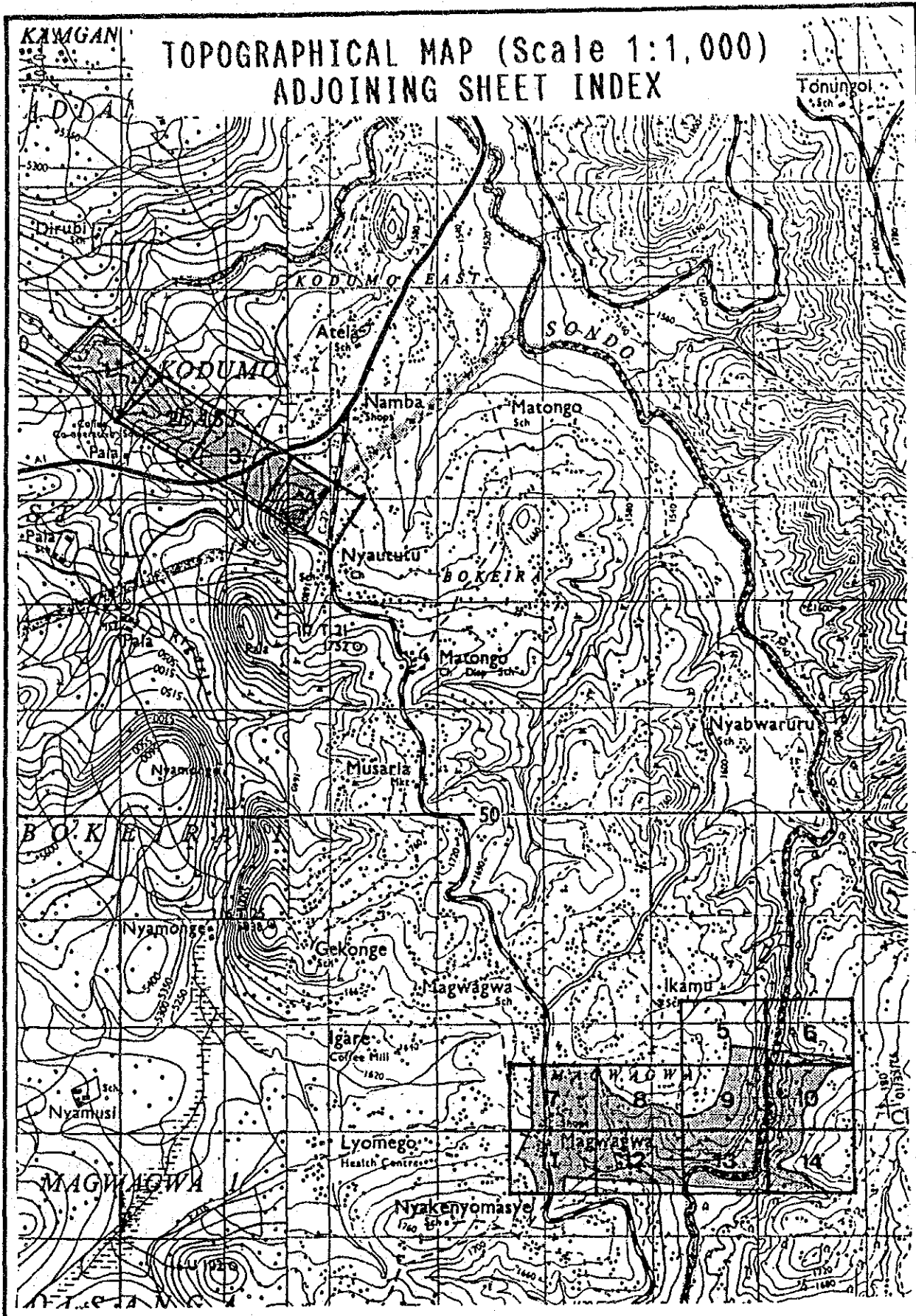

Figure 3.3 Sheet Number Index of Topographic Maps on a Scale of 1 to 1,000

REPUBLIC OF KENYA
MAGWAGWA HYDROELECTRIC
POWER DEVELOPMENT PROJECT
JAPAN INTERNATIONAL COOPERATION AGENCY

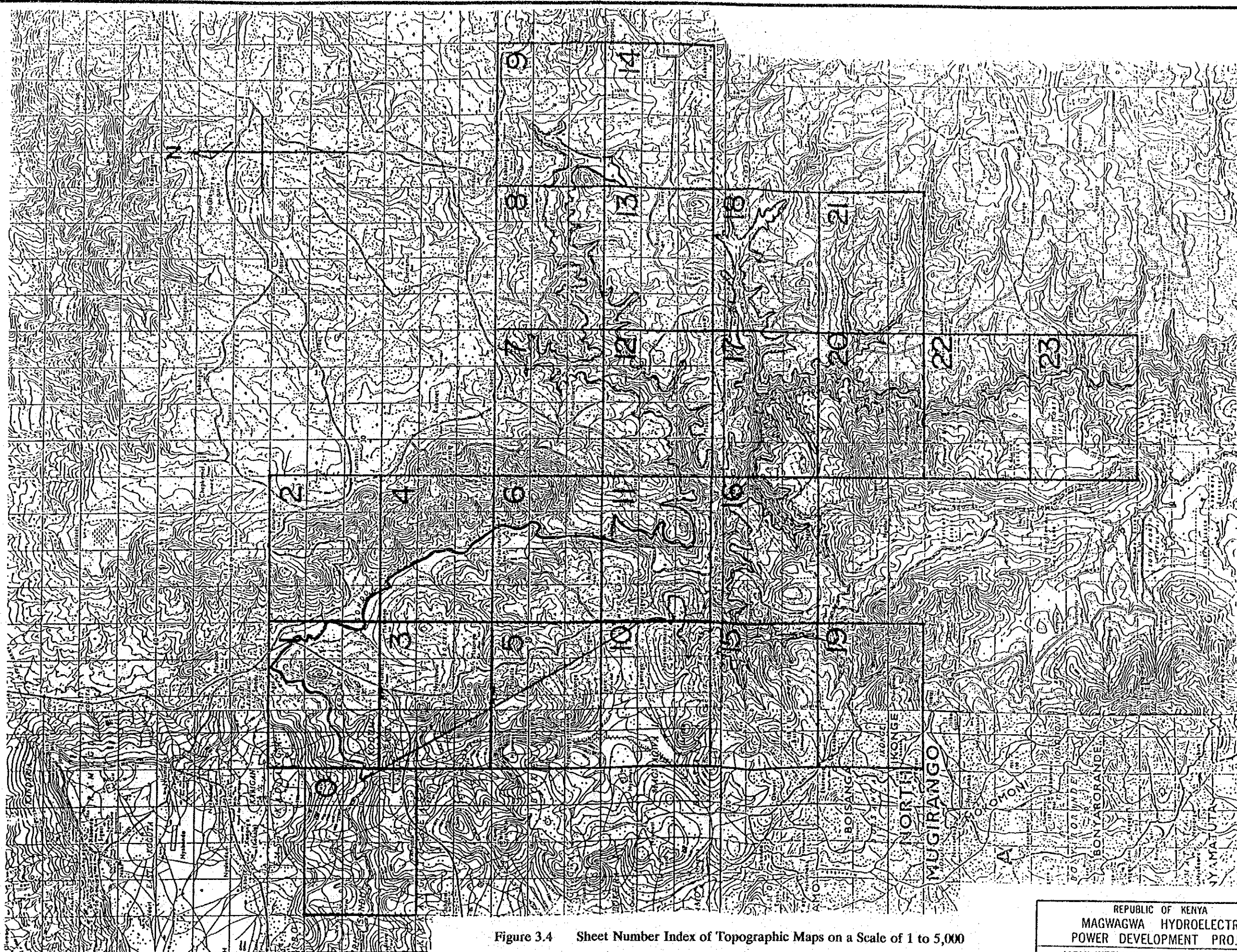

Figure 3.4 Sheet Number Index of Topographic Maps on a Scale of 1 to 5,000

REPUBLIC OF KENYA
 MAGWAGWA HYDROELECTRIC
 POWER DEVELOPMENT PROJECT
 JAPAN INTERNATIONAL COOPERATION AGENCY

DATA BOOK II.
GEOLOGY









II.1 Seismic Exploration

Table 1 SEISMIC EXPLORATION







Drawing No.	Line (Length in meter)	Alignment
1.	Damsite SD1 (730 m)	Crosssectional Line
2.	Damsite SD2 (740 m)	Crosssectional Line
3.	Damsite SD3 (740 m)	Crosssectional Line
4.	Damsite SD4 (700 m)	Longitudinal Line
5.	Damsite SD5 (1/2) (0 - 800 m)	Longitudinal Line
6.	Damsite SD5 (2/2) (800 - 1,200 m)	Longitudinal Line
7.	Saddle Damsite SS (600 m)	Crosssectional Line
8.	Waterway SW1 (310 m)	Intake-Headrace Tunnel
9.	Waterway SW2 (1,010 m)	Headrace Tunnel
10.	Waterway SW3 (1,000 m)	Headrace Tunnel
11.	Waterway SW4 (1/2) (0 - 1,100 m)	Surge Tank-Power House
12.	Waterway SW4 (2/2) (1,100 - 2,200 m)	Power House-Outlet
13.	Waterway SW5 (300 m)	Power House
14.	Rigari Quarry SQ1 (500 m)	Longitudinal Line
15.	Rigari Quarry SQ2 (300 m)	Crosssectional Line
16.	Rigari Quarry SQ3 (300 m)	Crosssectional Line

Total 14 Lines, 10,630 m

LITHOLOGY IN BORING LOG

-  TOP SOIL
-  RESIDUAL SOIL/DEBRIS
-  RIVER DEPOSITS
-  ANDESITE
-  TUFF - BRECCIA
-  SANDSTONE
-  QUARTZITE
-  LIME STONE
-  DOLERITE

WEATHERING CONDITION OF DRILLED CORE

-  COMPLETELY WEATHERED
-  WEATHERED
-  MODERATELY WEATHERED
-  FRACTURED SECTION
-  COMPLETELY WEATHERED IN GRANODIORITE
-  HEAVILY WEATHERED IN GRANODIORITE

EXPLANATION OF PROFILE

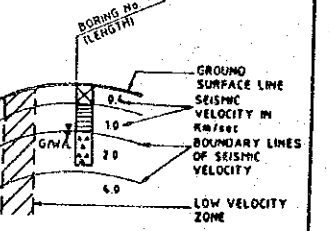

NOTE: G/W/L = GROUND WATER LEVEL AT THE END OF ALL DRILLING WORKS

SEISMIC EXPLORATION

REPUBLIC OF KENYA
MAGWAGWA HYDROELECTRIC POWER DEVELOPMENT PROJECT

JAPAN INTERNATIONAL CO-OPERATION AGENCY
DATE: NOV. 1990 SHEET 1 OF 16

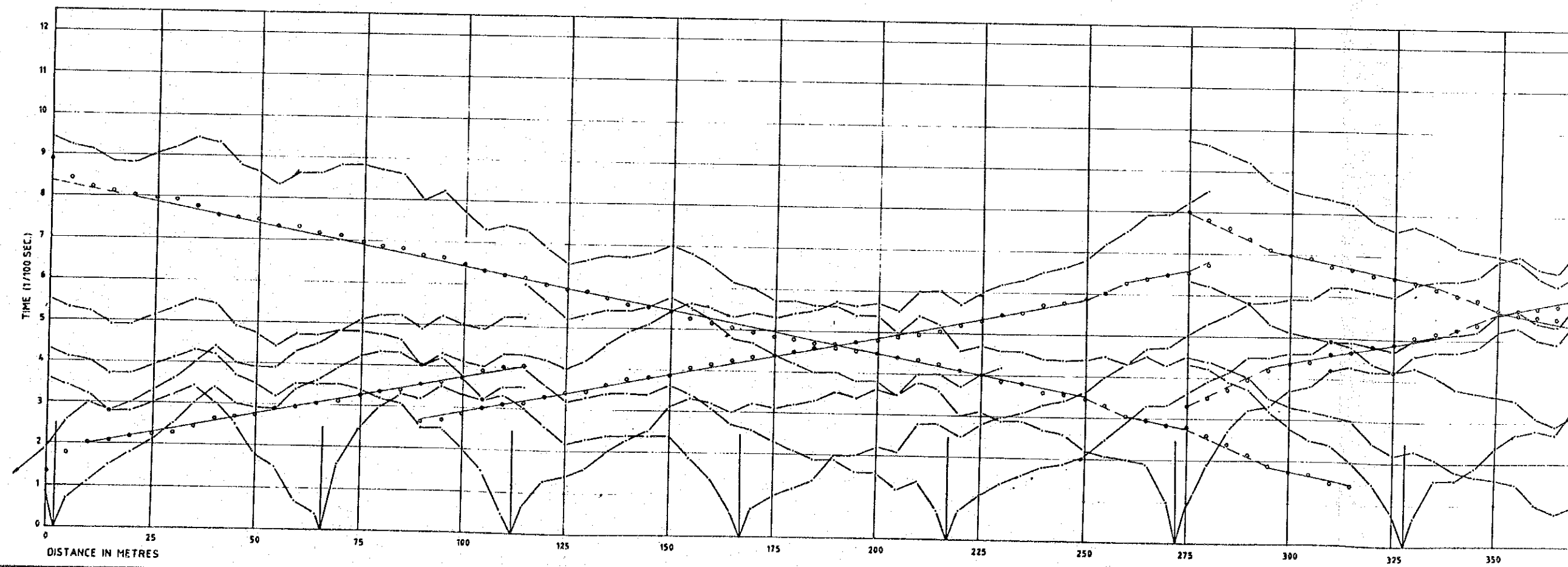
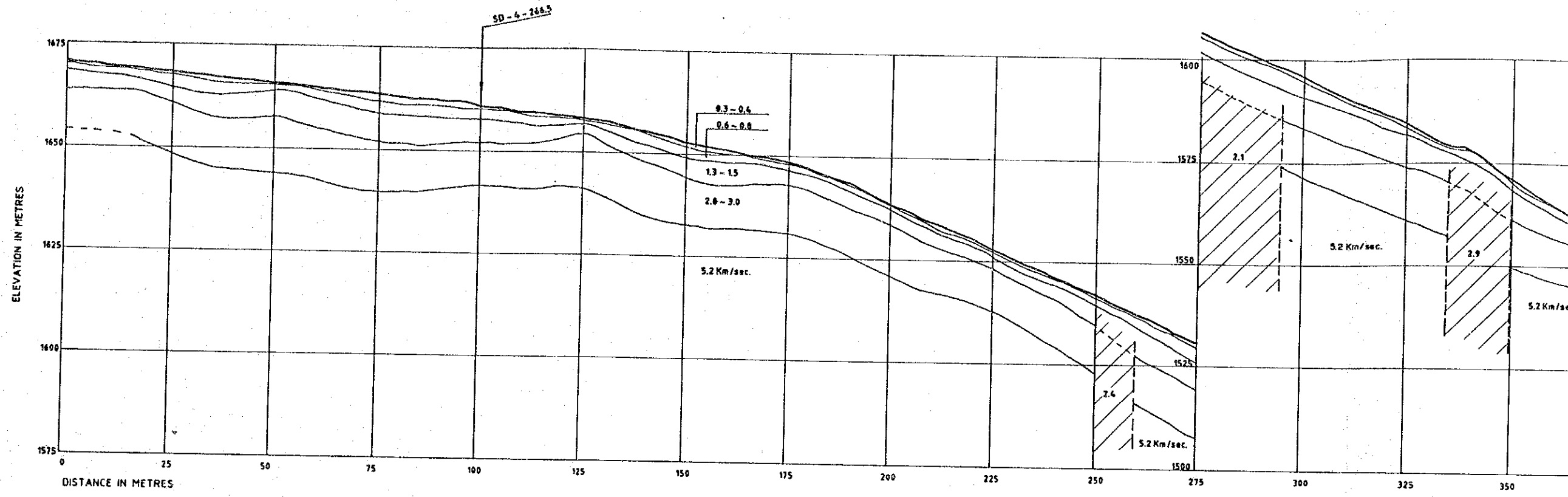



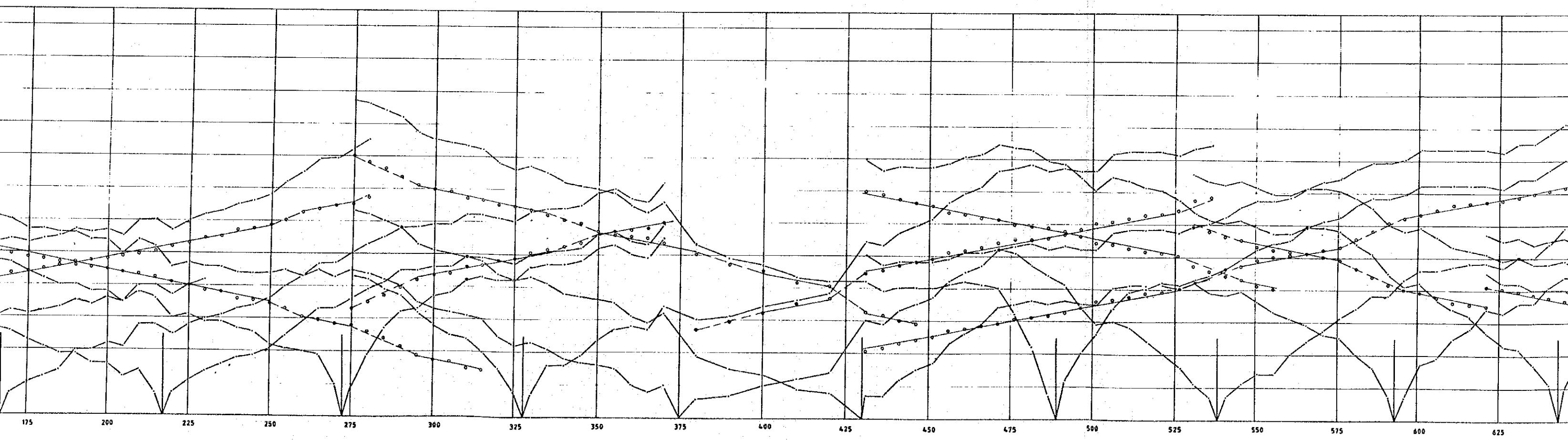
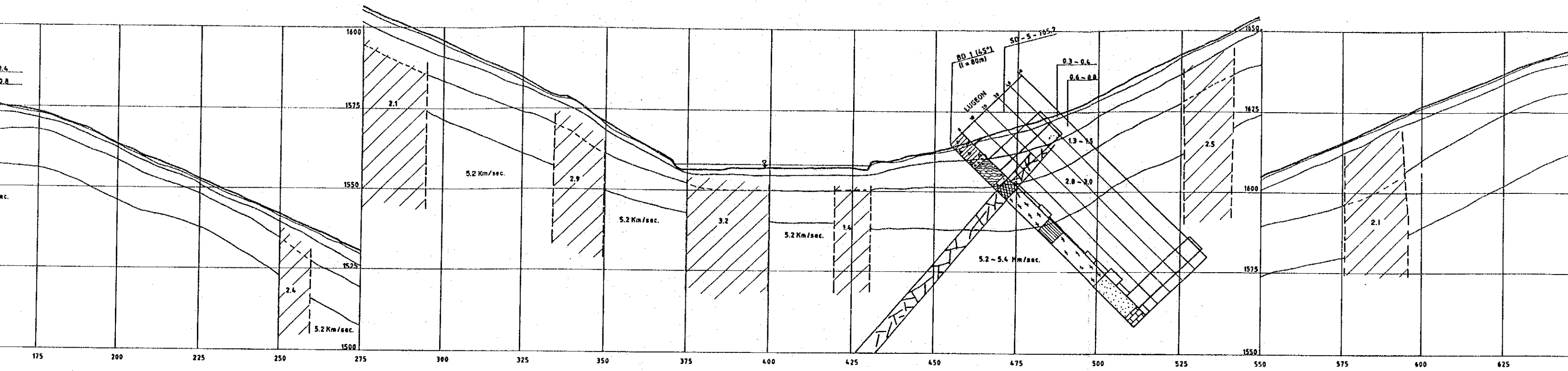



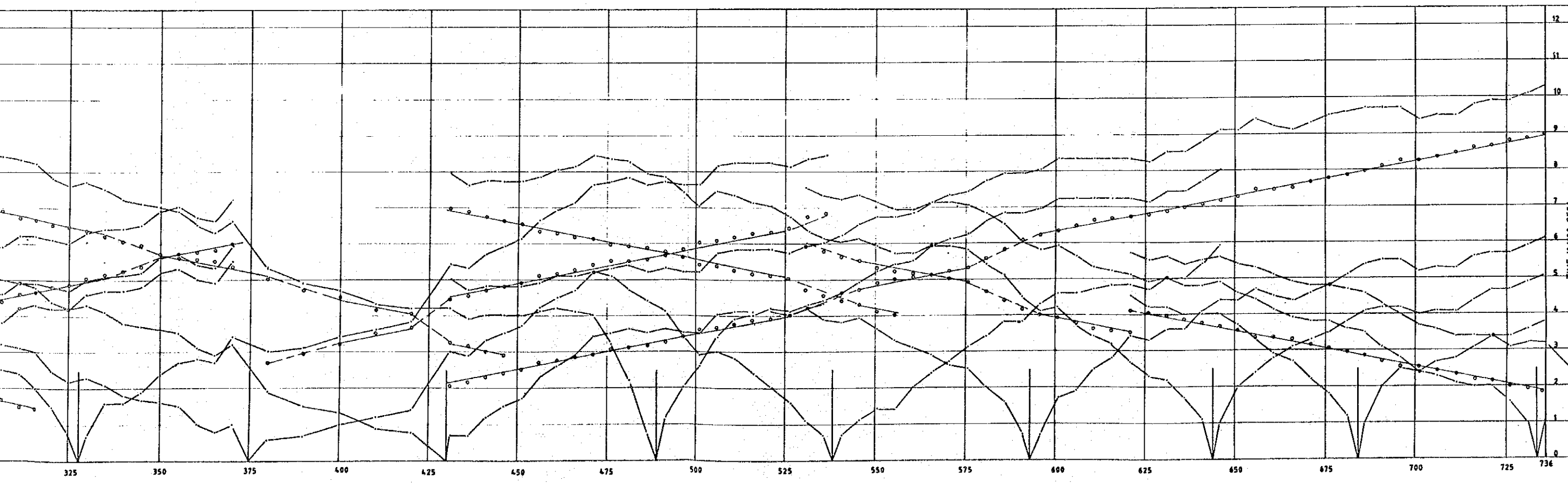
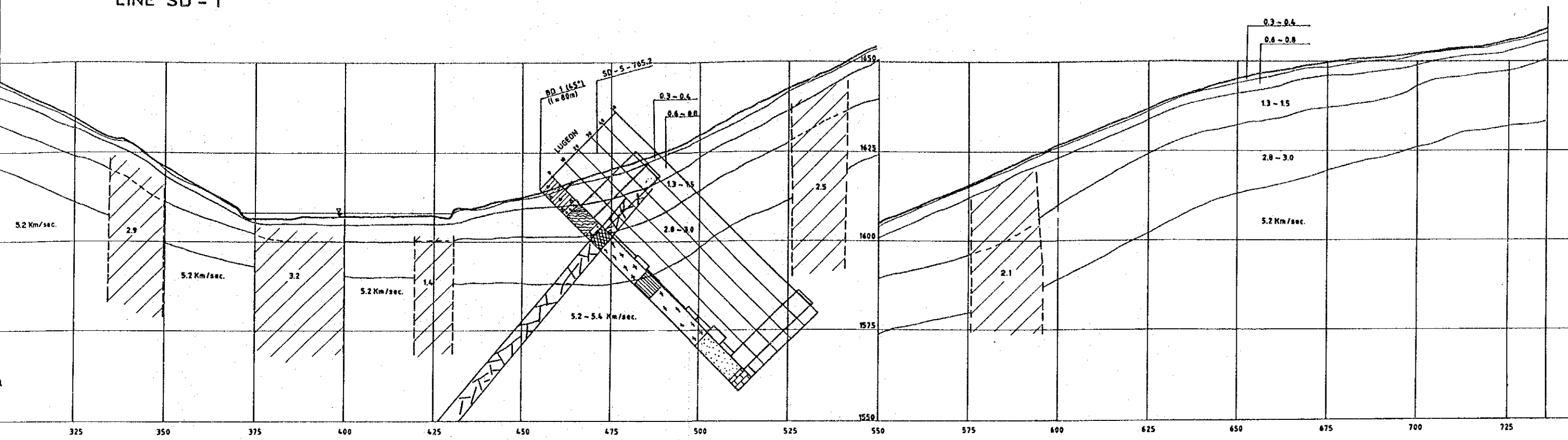

LINE SD - 1









LINE SD - 1



LITHOLOGY IN BORING LOG

-  TOP SOIL
-  RESIDUAL SOIL / DEBRIS
-  RIVER DEPOSITS
-  ANDESITE
-  TUFF - BRECCIA
-  SANDSTONE
-  QUARTZITE
-  LIME STONE
-  DOLERITE

WEATHERING CONDITION OF DRILLED CORE

-  COMPLETELY WEATHERED
-  WEATHERED
-  MODERATELY WEATHERED
-  FRACTURED SECTION
-  COMPLETELY WEATHERED IN GRANODIORITE
-  HEAVILY WEATHERED IN GRANODIORITE

EXPLANATION OF PROFILE

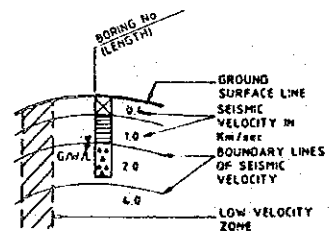

NOTE: G.W.L. = GROUND WATER LEVEL AT THE END OF ALL DRILLING WORKS

SEISMIC EXPLORATION

REPUBLIC OF KENYA

MAGWAGWA HYDROELECTRIC POWER DEVELOPMENT PROJECT

JAPAN INTERNATIONAL CO-OPERATION AGENCY

DATE: NOV. 1990 SHEET 2 OF 16

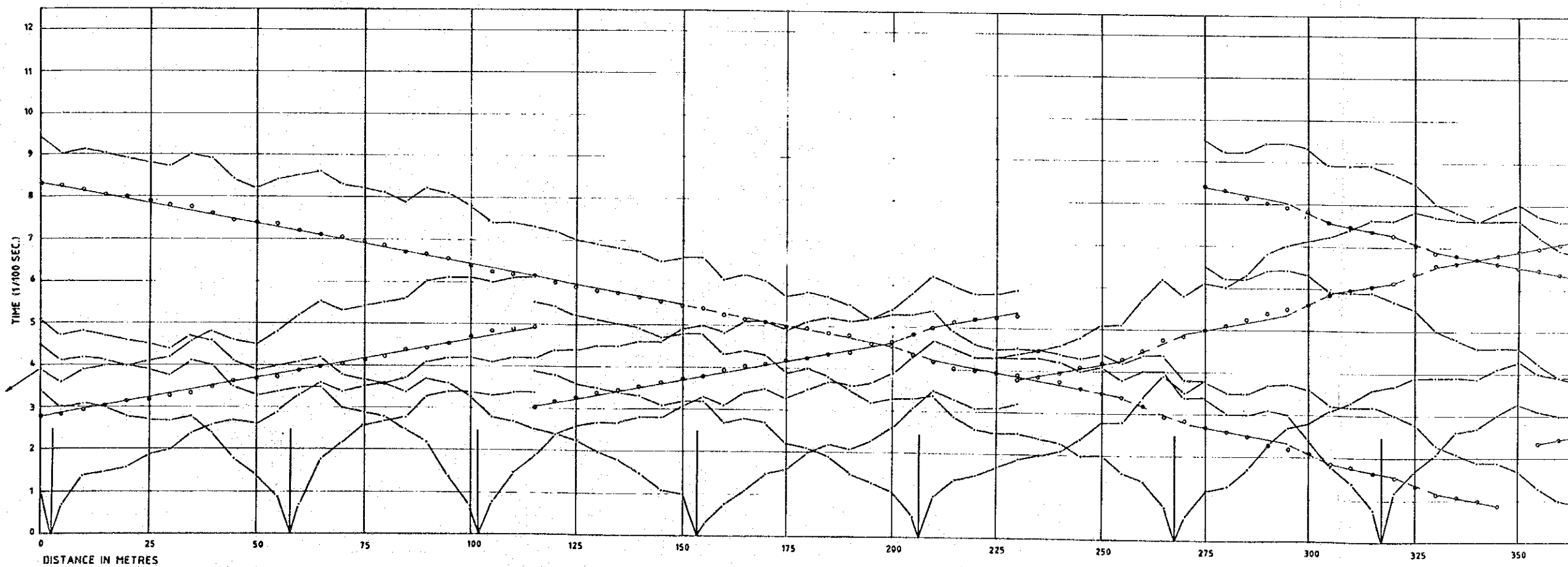
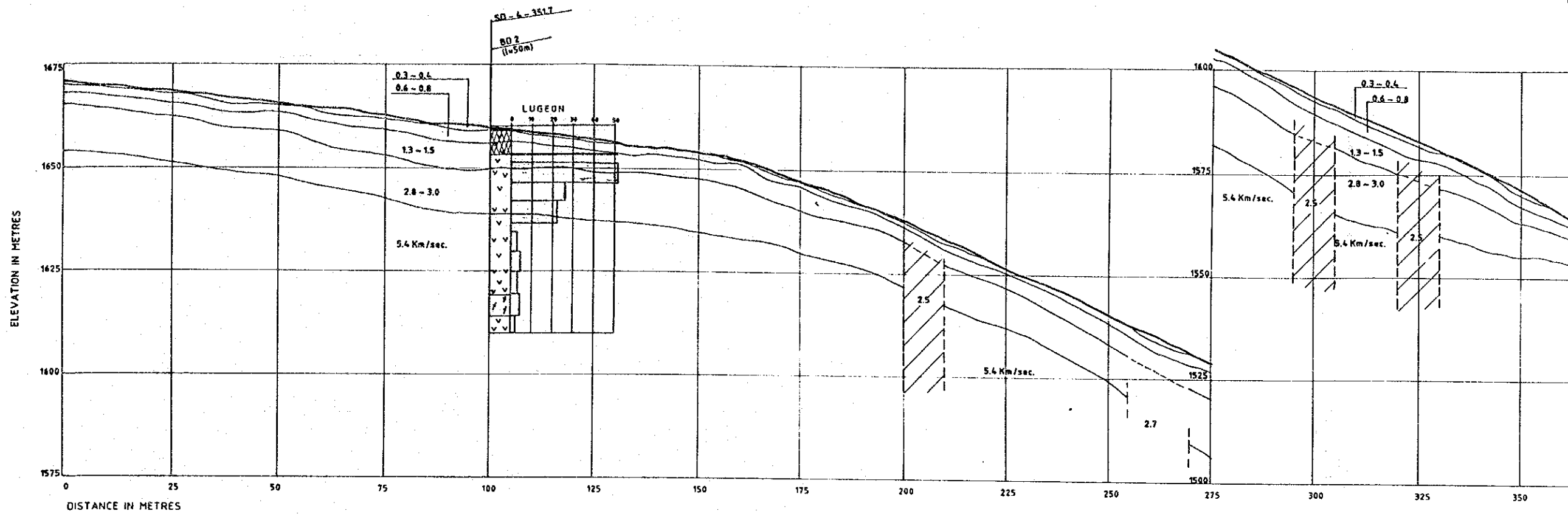



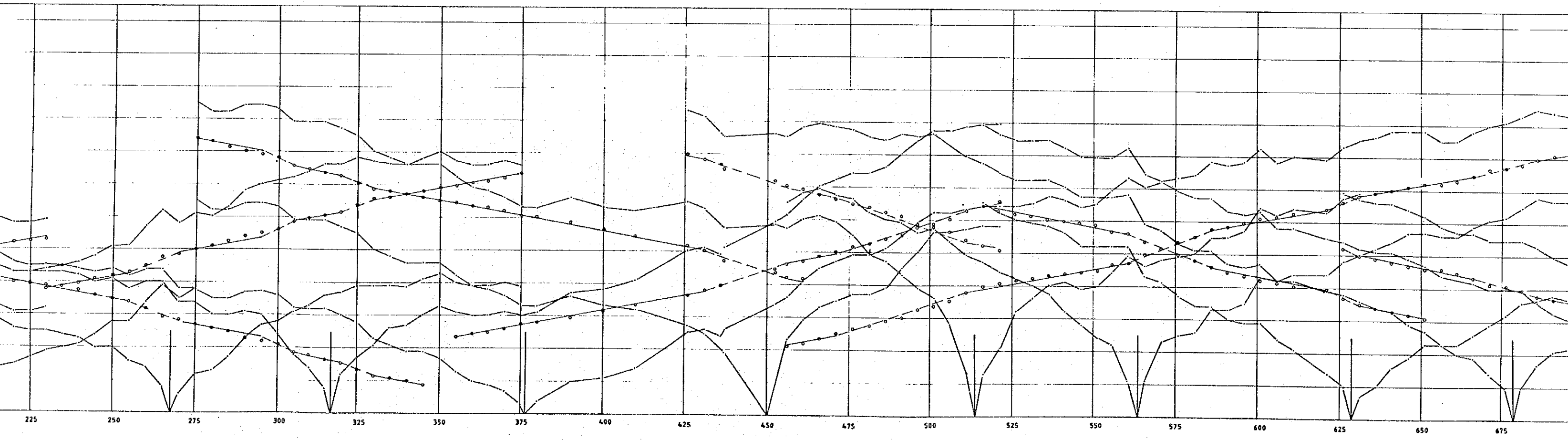
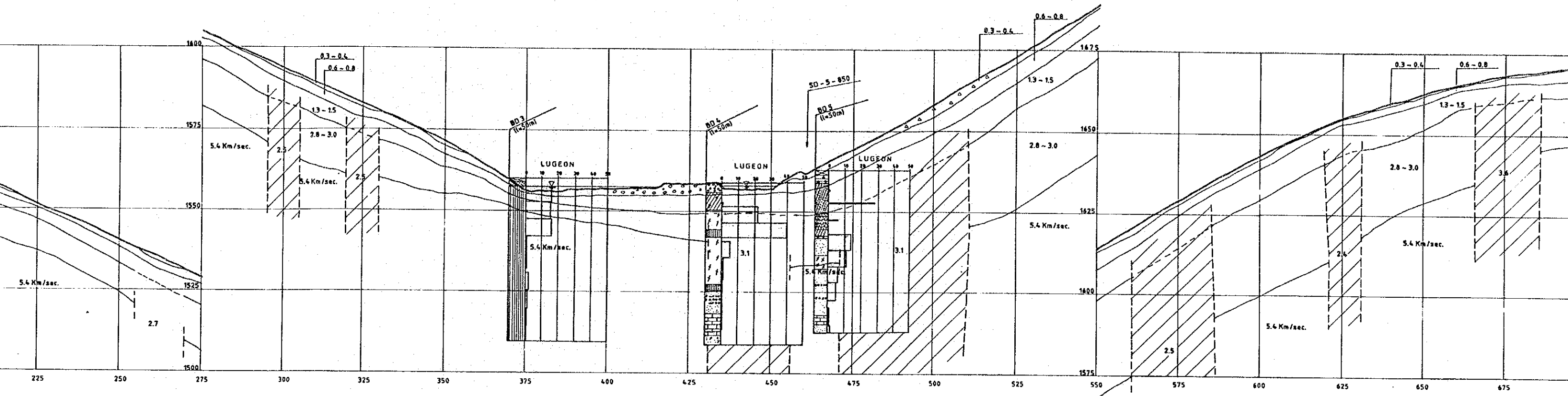



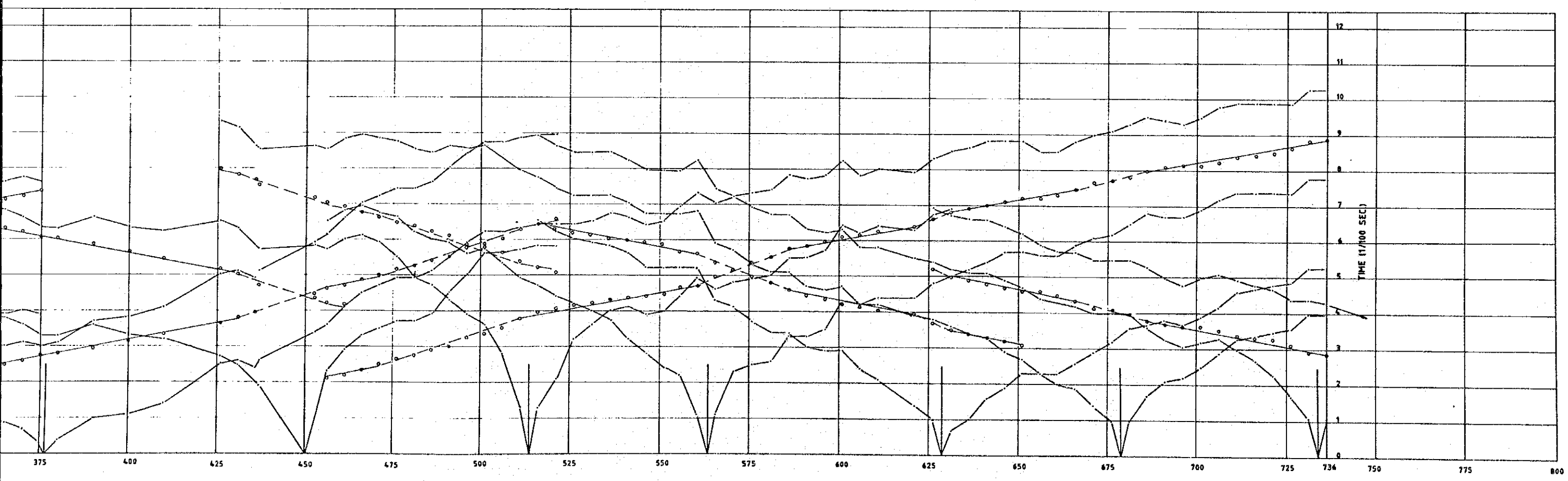
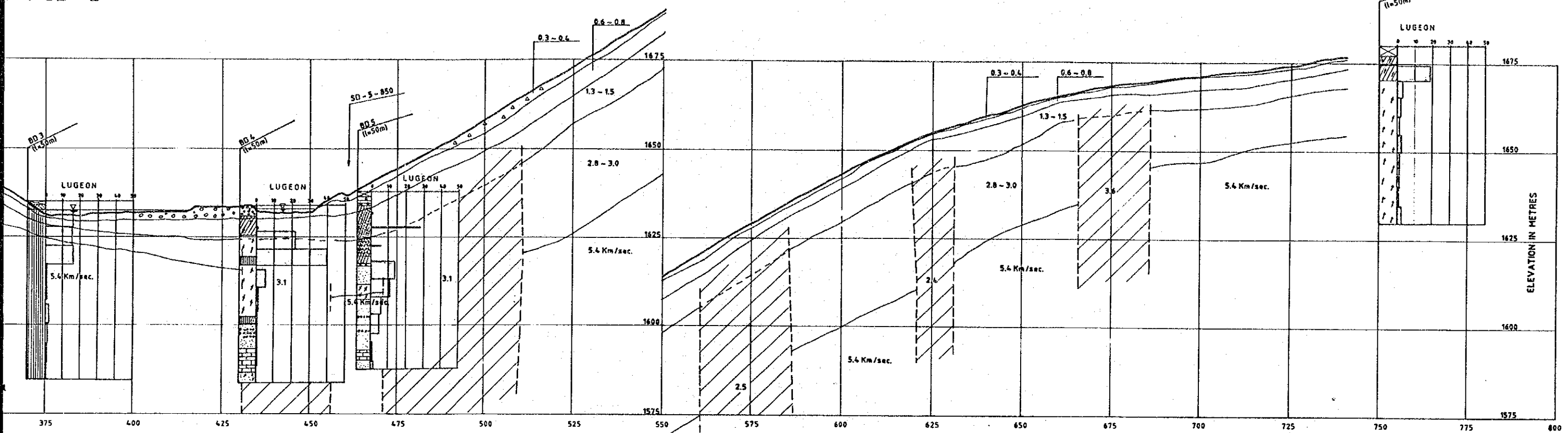

LINE SD - 2









LINE SD - 2



LITHOLOGY IN BORING LOG

-  TOP SOIL
-  RESIDUAL SOIL / DEBRIS
-  RIVER DEPOSITS
-  ANDESITE
-  TUFF - BRECCIA
-  SANDSTONE
-  QUARTZITE
-  LIME STONE
-  DOLERITE

WEATHERING CONDITION OF DRILLED CORE

-  COMPLETELY WEATHERED
-  WEATHERED
-  MODERATELY WEATHERED
-  FRACTURED SECTION
-  COMPLETELY WEATHERED IN GRANODIORITE
-  HEAVILY WEATHERED IN GRANODIORITE

EXPLANATION OF PROFILE

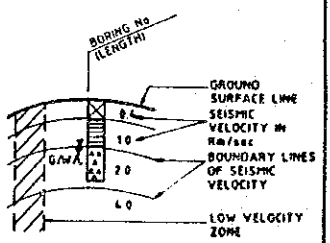

NOTE: G/W/L = GROUND WATER LEVEL AT THE END OF ALL DRILLING WORKS

SEISMIC EXPLORATION

REPUBLIC OF KENYA
MAGWAGWA HYDROELECTRIC POWER DEVELOPMENT PROJECT

JAPAN INTERNATIONAL CO-OPERATION AGENCY

DATE: NOV. 1990 SHEET 3 OF 16

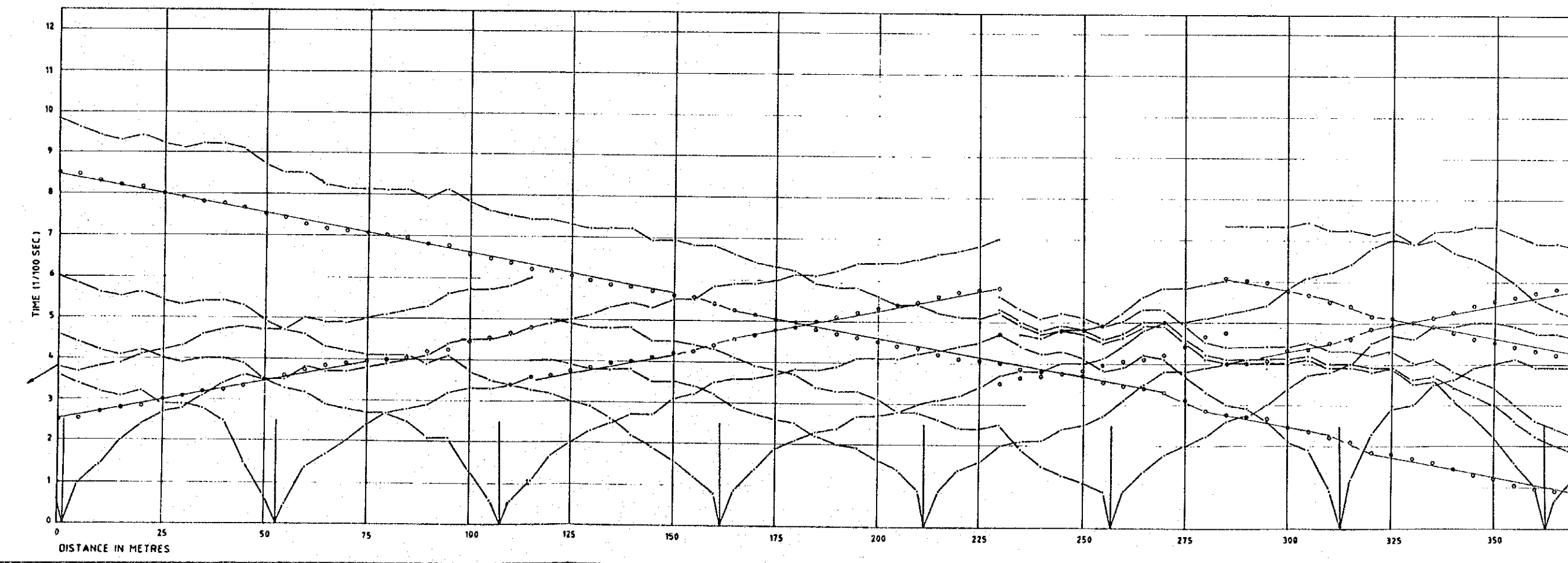
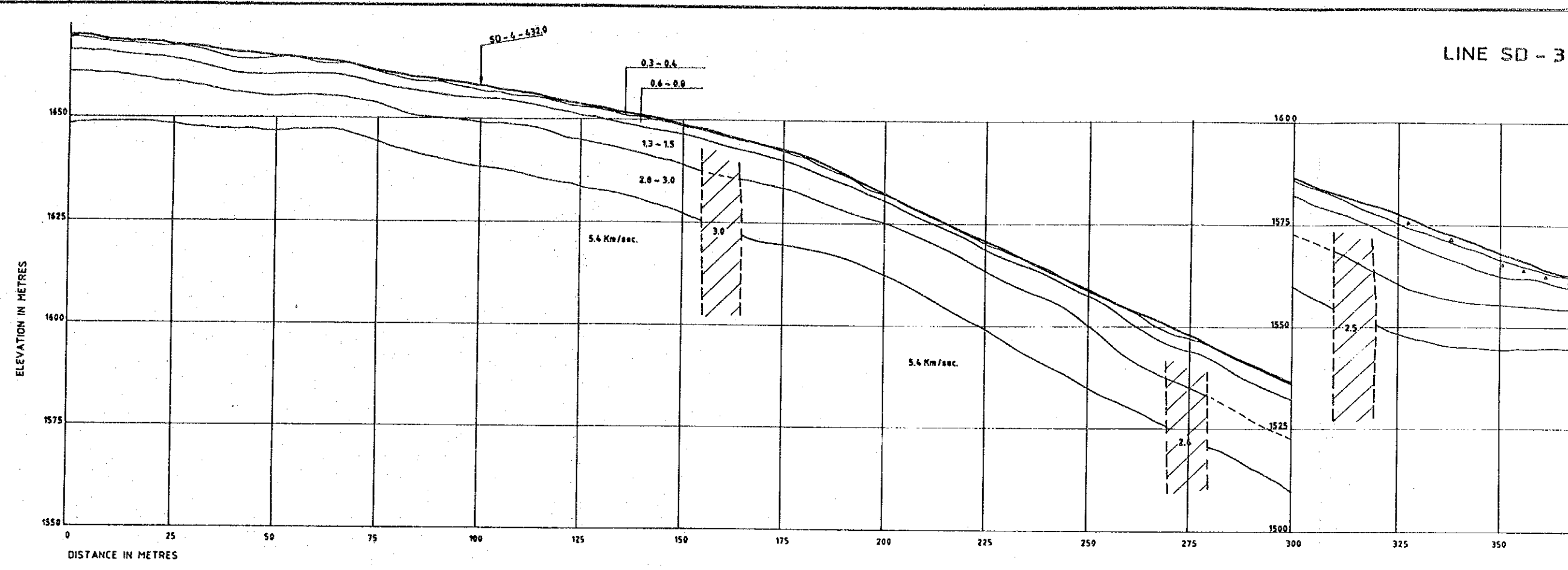



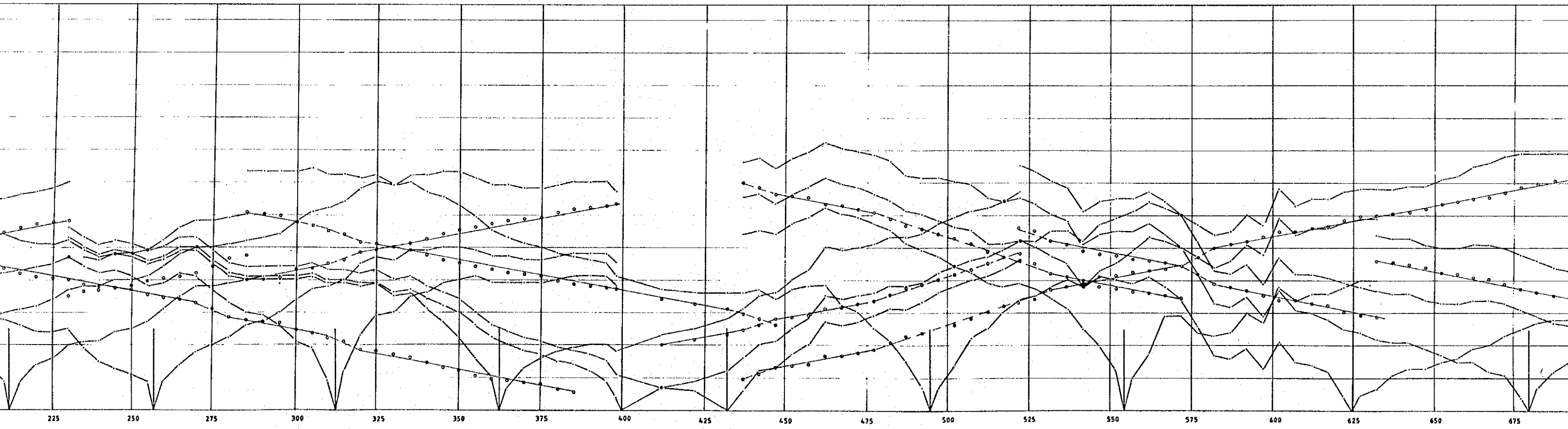
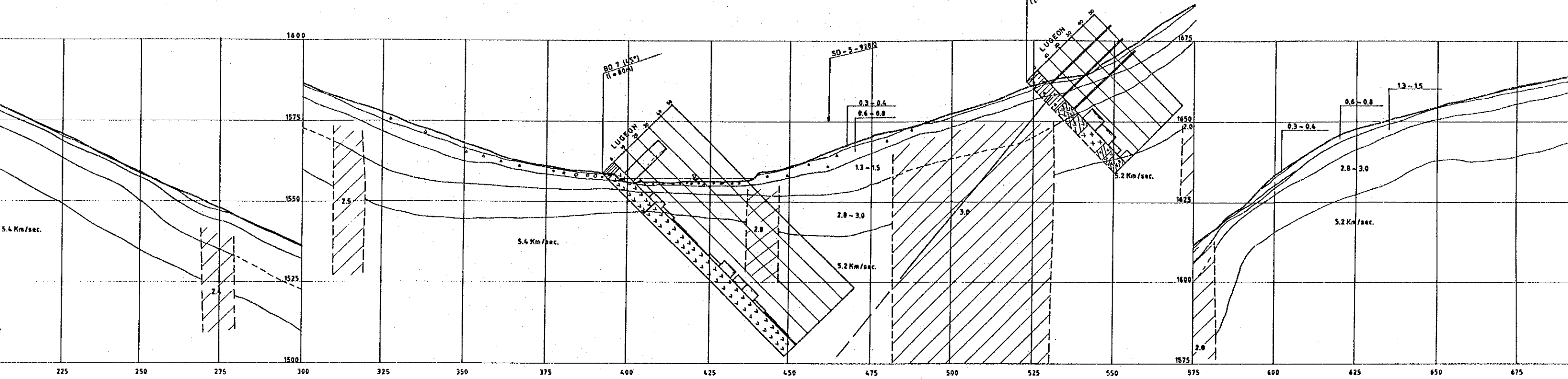



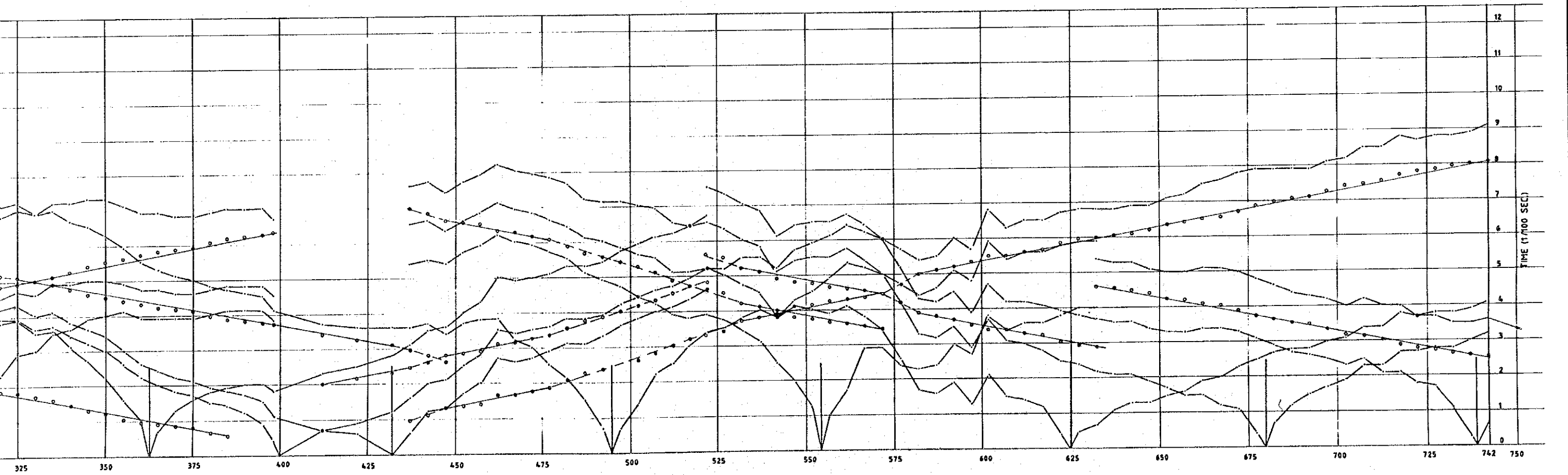
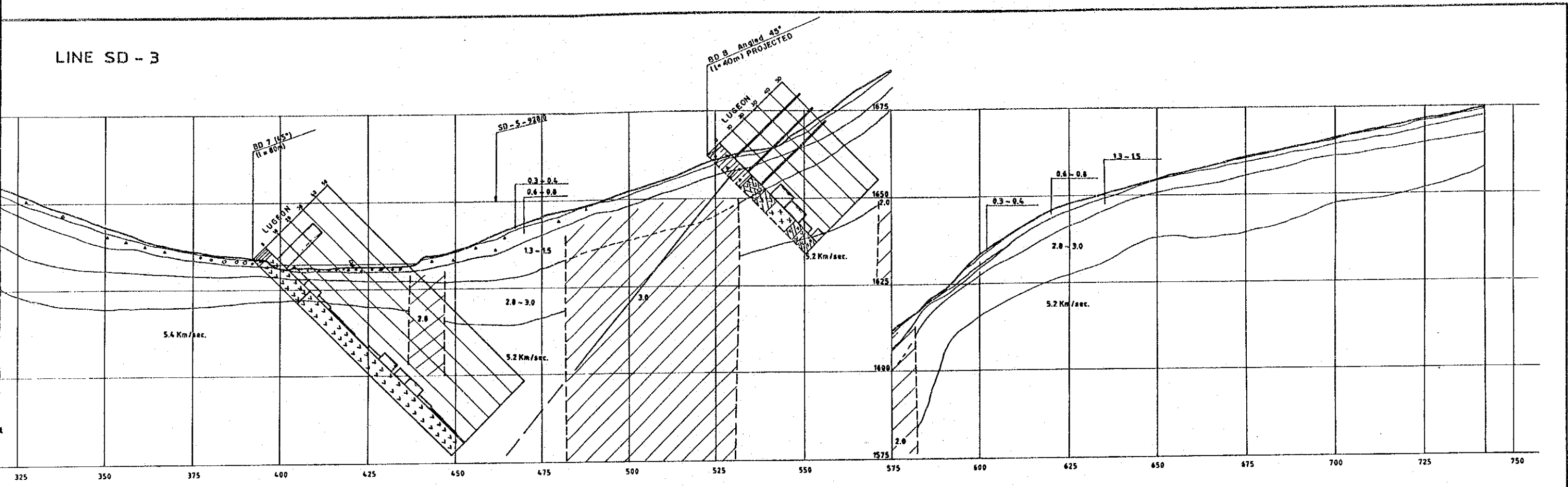

LINE SD - 3









LINE SD - 3



LITHOLOGY IN BORING LOG

-  TOP SOIL
-  RESIDUAL SOIL/DEBRIS
-  RIVER DEPOSITS
-  ANDESITE
-  TUFF - BRECCIA
-  SANDSTONE
-  QUARTZITE
-  LIME STONE
-  DOLERITE

WEATHERING CONDITION OF DRILLED CORE

-  COMPLETELY WEATHERED
-  WEATHERED
-  MODERATELY WEATHERED
-  FRACTURED SECTION
-  COMPLETELY WEATHERED IN GRANODIORITE
-  HEAVILY WEATHERED IN GRANODIORITE

EXPLANATION OF PROFILE

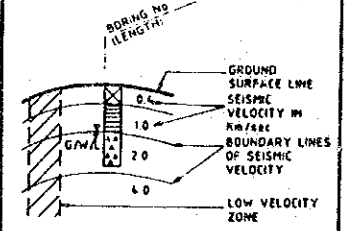

NOTE: G/W/L = GROUND WATER LEVEL AT THE END OF ALL DRILLING WORKS

SEISMIC EXPLORATION

REPUBLIC OF KENYA
MAGWAGWA HYDROELECTRIC POWER DEVELOPMENT PROJECT



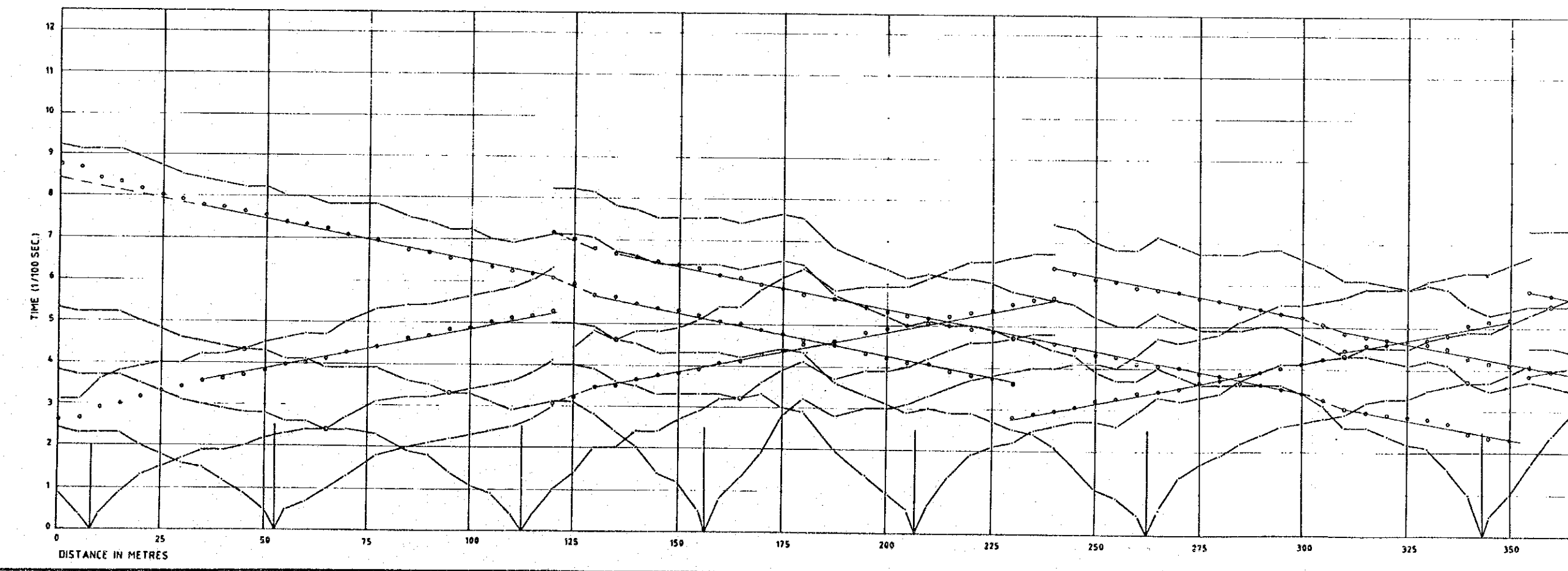
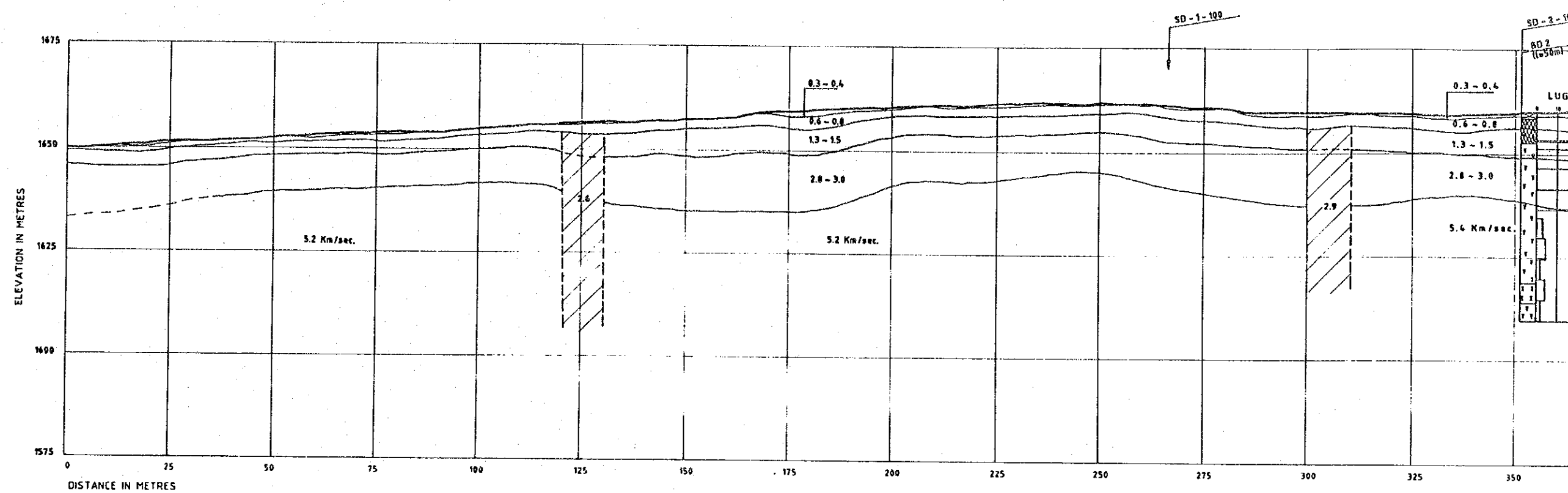



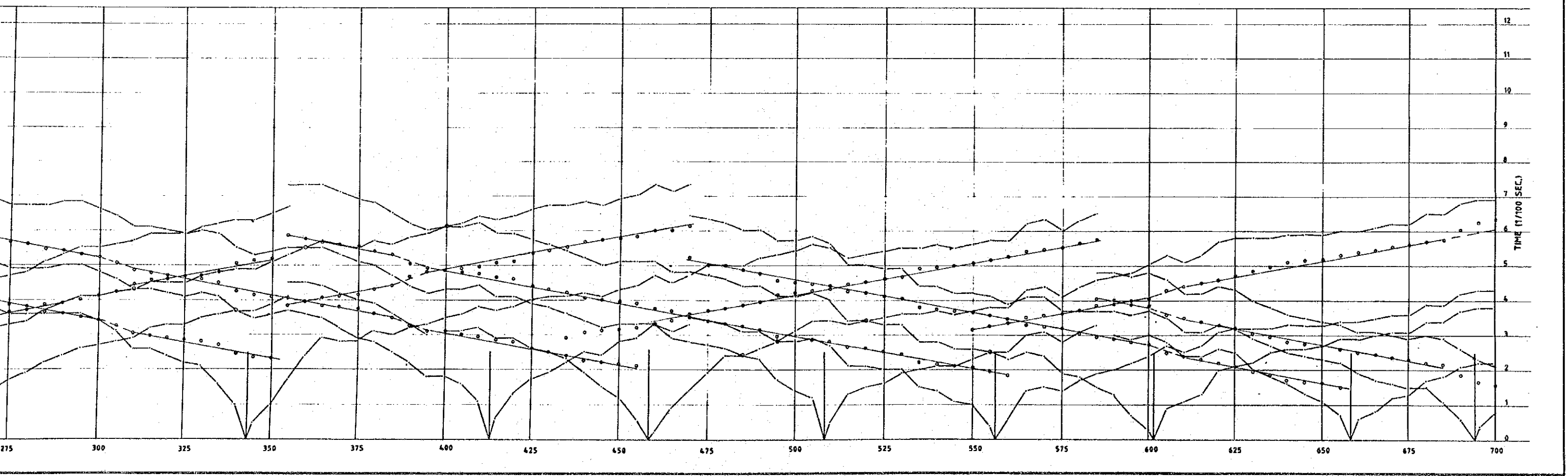
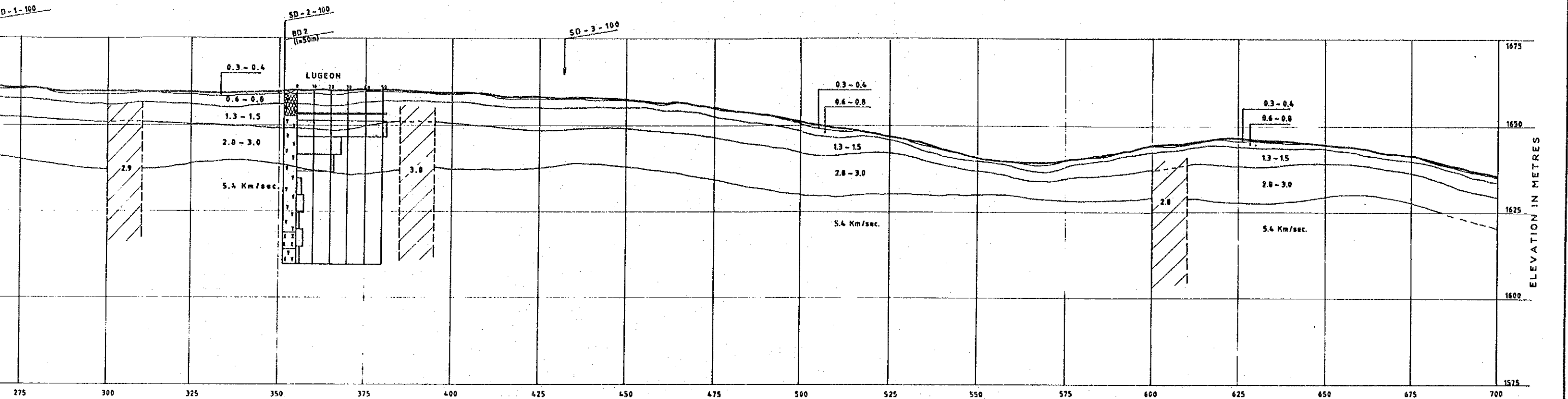

JAPAN INTERNATIONAL CO-OPERATION AGENCY









LINE SD - 4



LITHOLOGY IN BORING LOG

-  TOP SOIL
-  RESIDUAL SOIL/DEBRIS
-  RIVER DEPOSITS
-  ANDESITE
-  TUFF - BRECCIA
-  SANDSTONE
-  QUARTZITE
-  LIME STONE
-  DOLERITE

WEATHERING CONDITION OF DRILLED CORE

-  COMPLETELY WEATHERED
-  WEATHERED
-  MODERATELY WEATHERED
-  FRACTURED SECTION
-  COMPLETELY WEATHERED IN GRANODIORITE
-  HEAVILY WEATHERED IN GRANODIORITE

EXPLANATION OF PROFILE

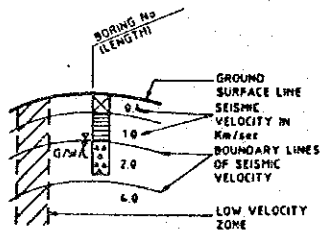

NOTE: G/W/L = GROUND WATER LEVEL AT THE END OF ALL DRILLING WORKS

SEISMIC EXPLORATION

REPUBLIC OF KENYA

MAGWAGWA HYDROELECTRIC POWER DEVELOPMENT PROJECT

JAPAN INTERNATIONAL CO-OPERATION AGENCY

DATE: NOV. 1999 SHEET 5 OF 16

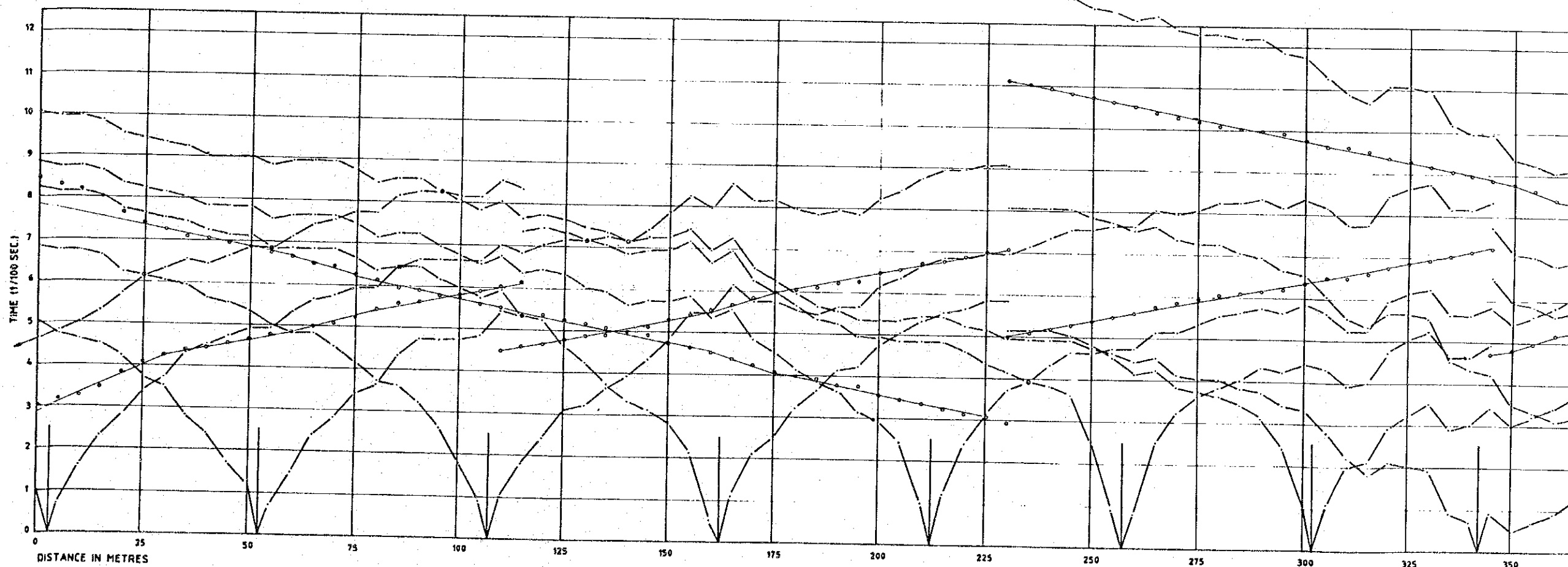
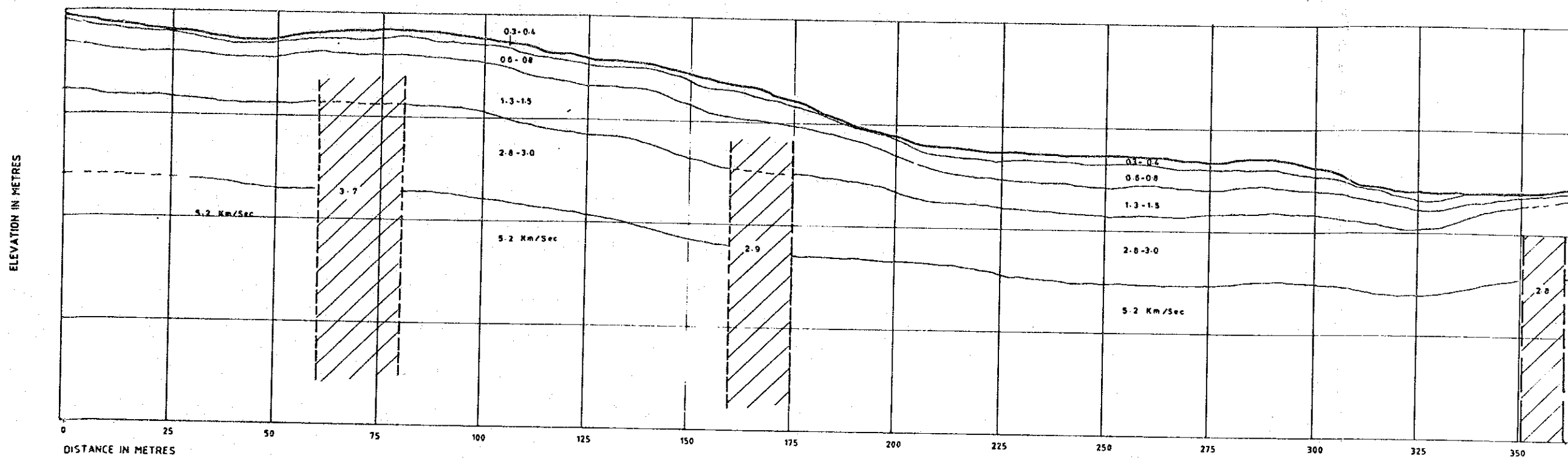





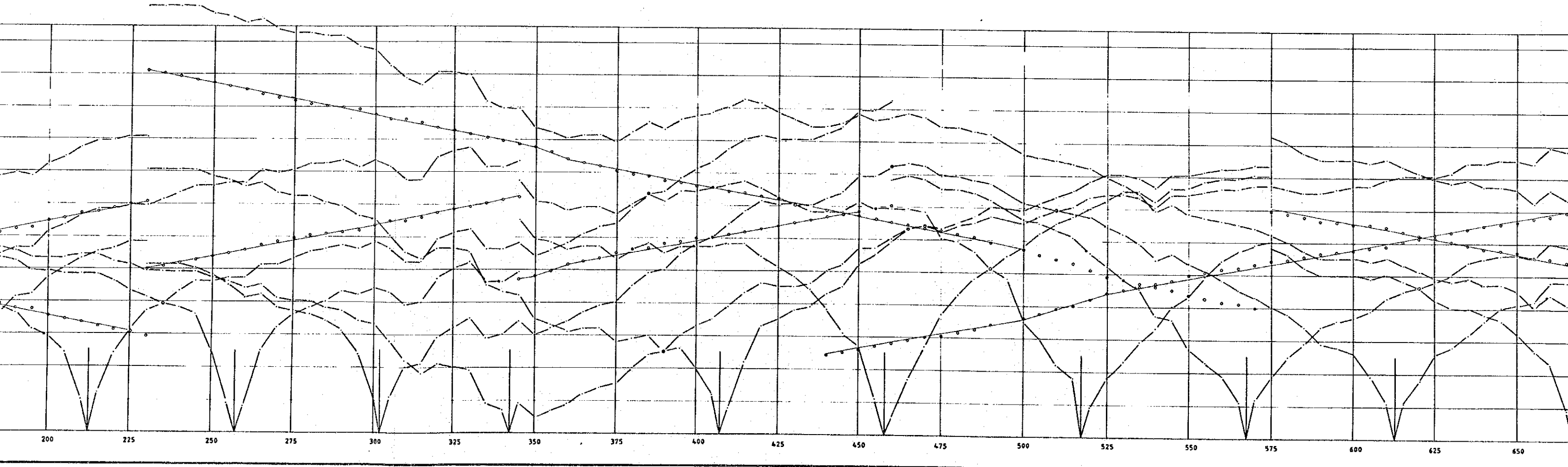
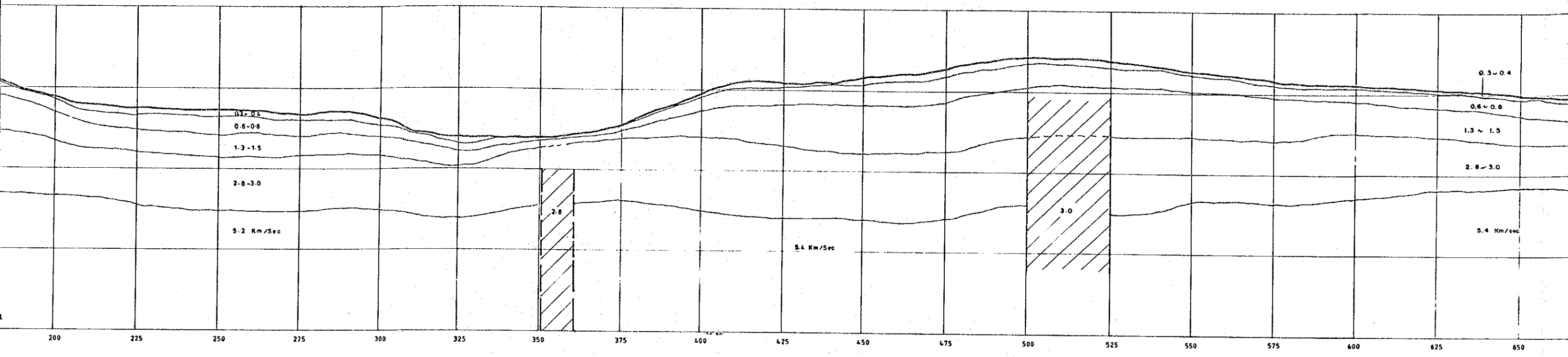

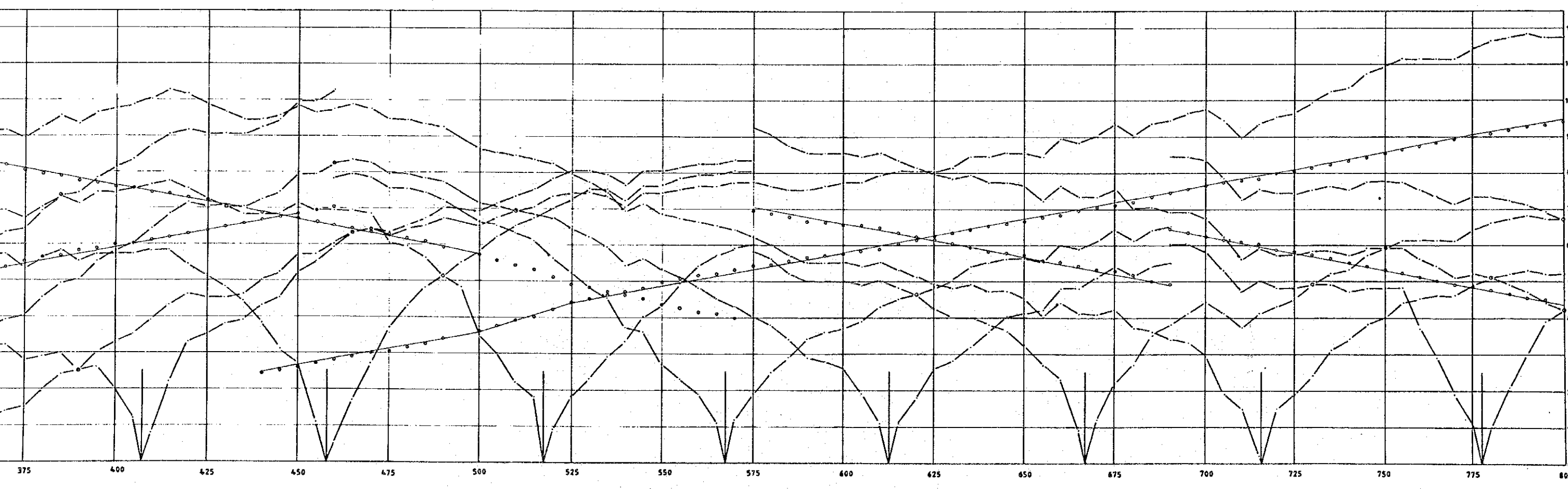
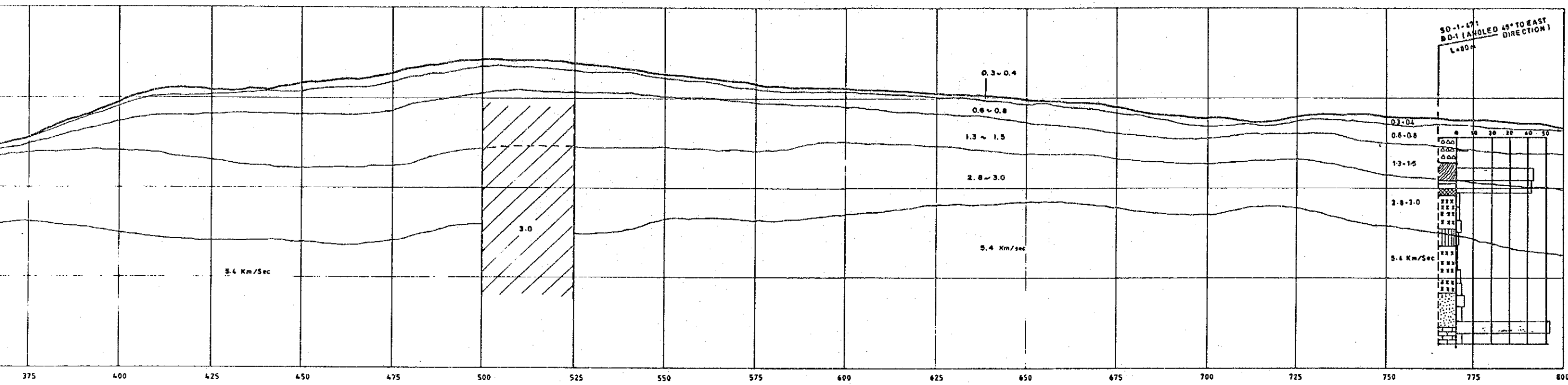

LINE SD - 5

SHEET 1 OF 2











LITHOLOGY IN BORING LOG

-  TOP SOIL
-  RESIDUAL SOIL/DEBRIS
-  RIVER DEPOSITS
-  ANDESITE
-  TUFF - BRECCIA
-  SANDSTONE
-  QUARTZITE
-  LIME STONE
-  DOLERITE

WEATHERING CONDITION OF DRILLED CORE

-  COMPLETELY WEATHERED
-  WEATHERED
-  MODERATELY WEATHERED
-  FRACTURED SECTION
-  COMPLETELY WEATHERED IN GRANODIORITE
-  HEAVILY WEATHERED IN GRANODIORITE

EXPLANATION OF PROFILE

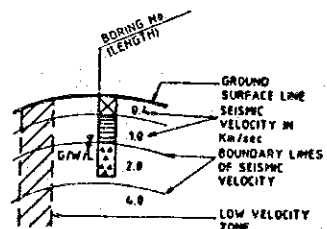

NOTE: G.W.L. = GROUND WATER LEVEL AT THE END OF ALL DRILLING WORKS

SEISMIC EXPLORATION

REPUBLIC OF KENYA
MAGWAGWA HYDROELECTRIC
POWER DEVELOPMENT
PROJECT

JAPAN INTERNATIONAL CO-OPERATION AGENCY

DATE: NOV. 1990 SHEET 6 OF 16

LINE SD - 5
SHEET 2 OF 2

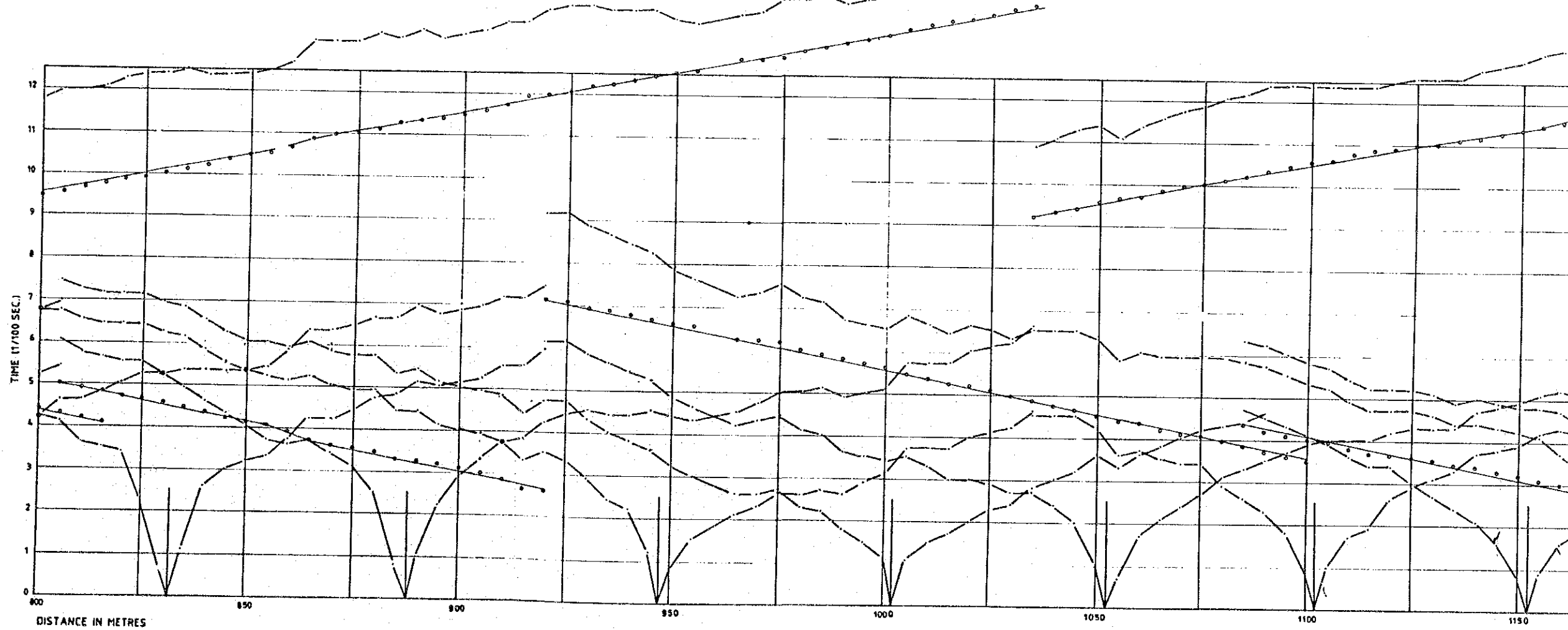
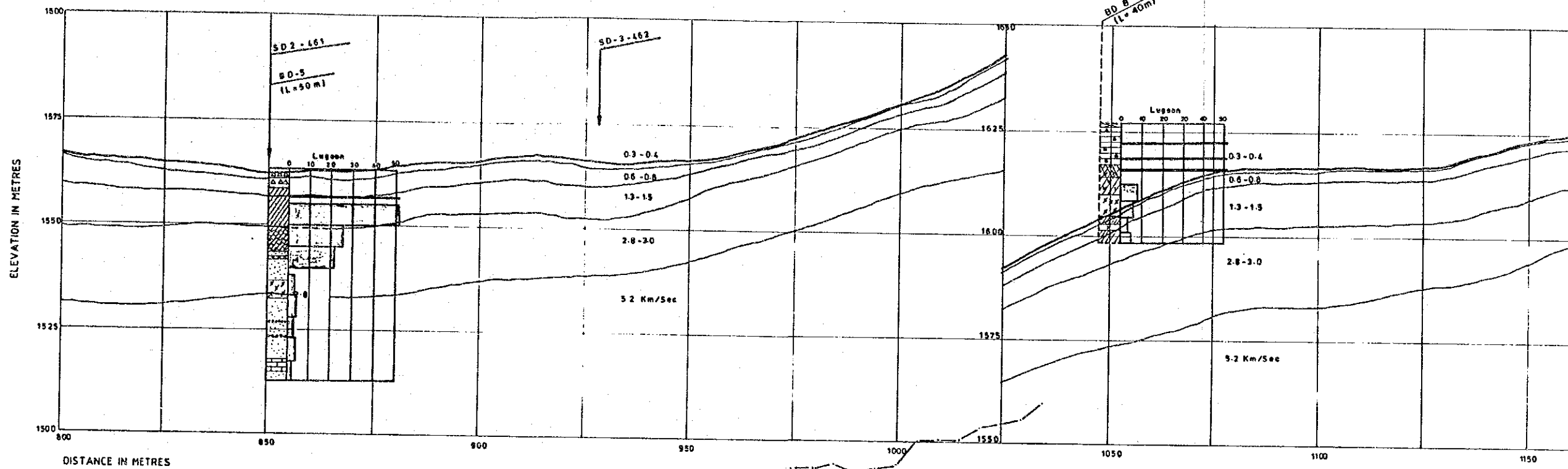

LINE SD - 5
SHEET 2 OF 2

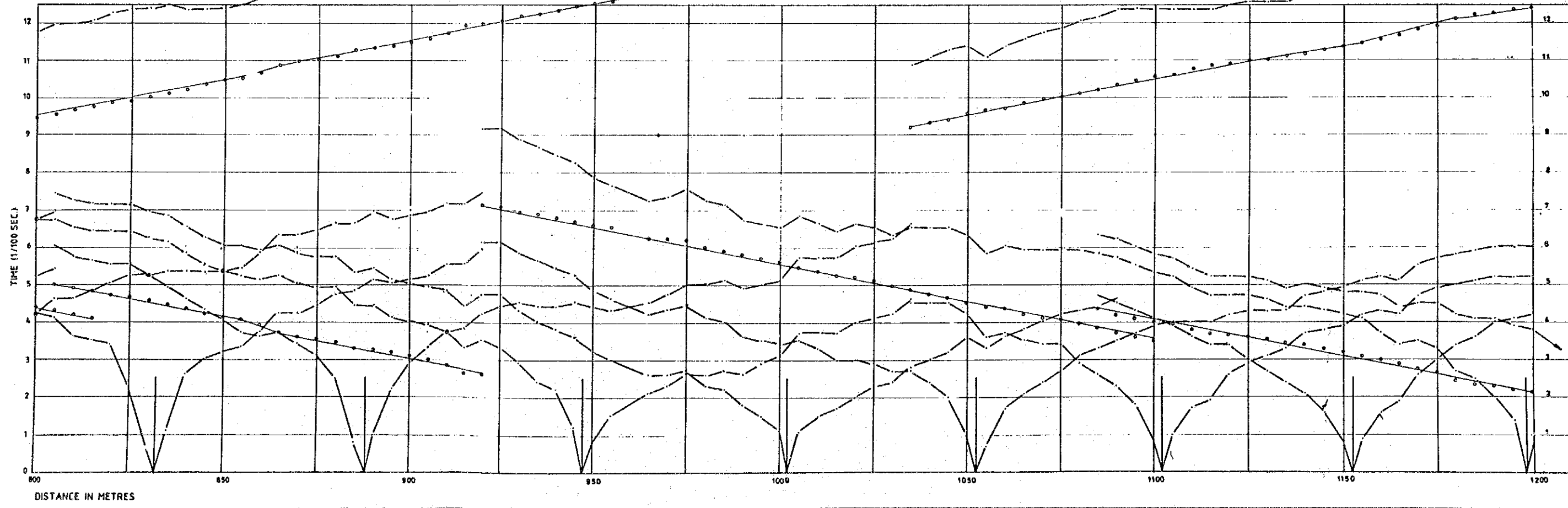
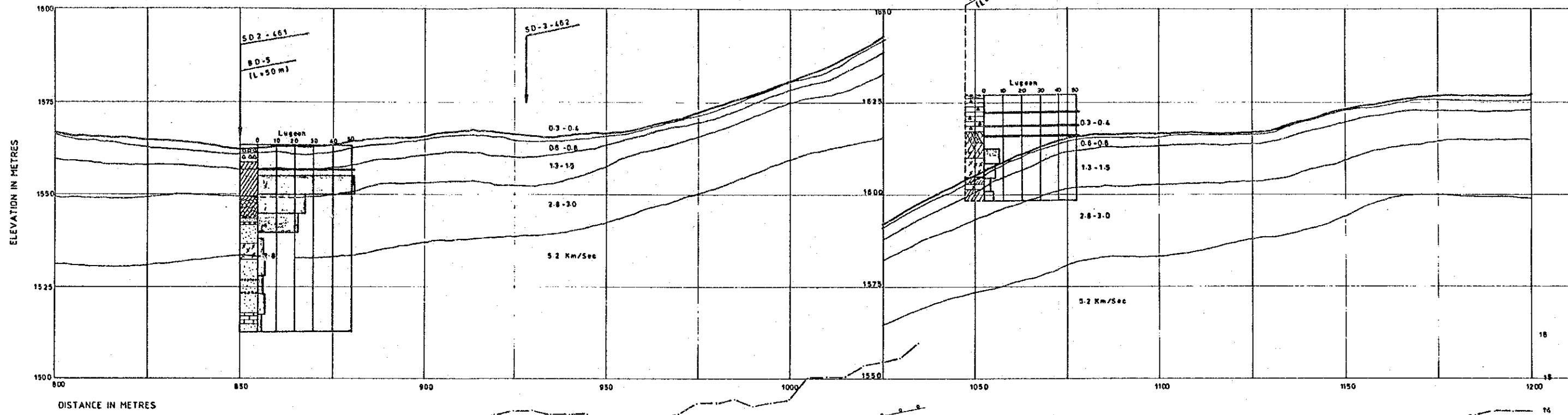

GEOLOGICAL PROFILE OF SADDLE DAMS

LITHOLOGY IN BORING LOG

- TOP SOIL
- RESIDUAL SOIL / DEBRIS
- RIVER DEPOSITS
- ANDESITE
- TUFF - BRECCIA
- SANDSTONE
- QUARTZITE
- LIME STONE
- DOLERITE

WEATHERING CONDITION OF DRILLED CORE

- COMPLETELY WEATHERED
- WEATHERED
- MODERATELY WEATHERED
- FRACTURED SECTION
- COMPLETELY WEATHERED IN GRANODIORITE
- HEAVILY WEATHERED IN GRANODIORITE

EXPLANATION OF PROFILE

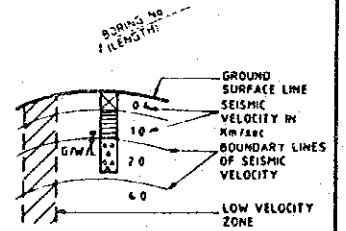

SEISMIC EXPLORATION

REPUBLIC OF KENYA
MAGWAGWA HYDROELECTRIC
POWER DEVELOPMENT
PROJECT

JAPAN INTERNATIONAL CO-OPERATION AGENCY

DATE: NOV. 1990 SHEET 7 OF 16

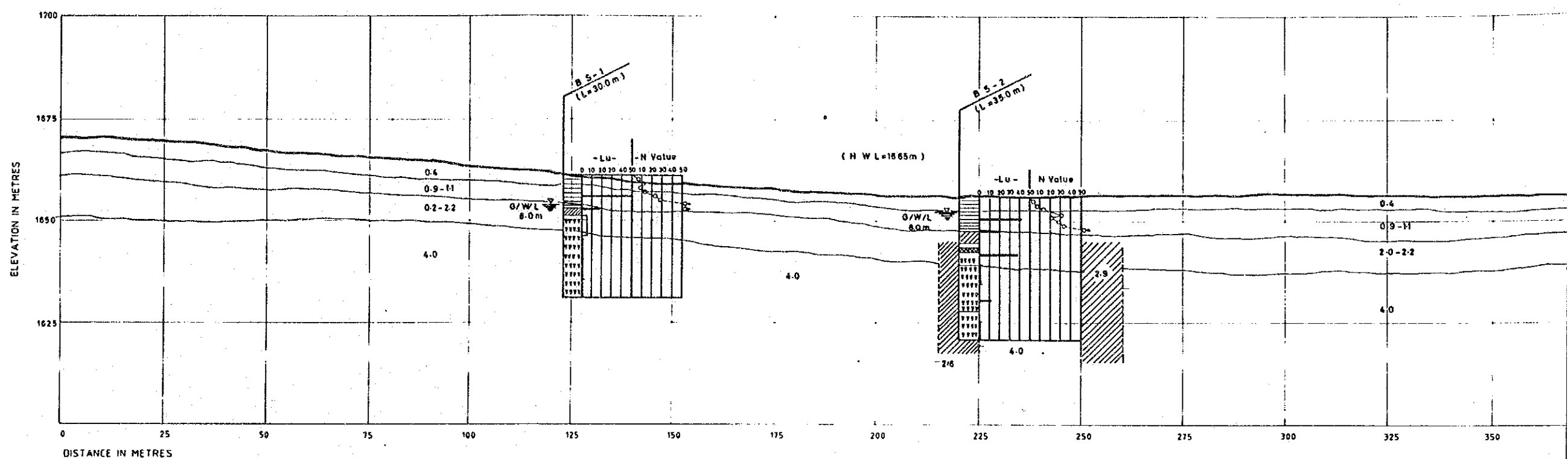

TIME - TRAVEL CURVE OF SADDLE DAMS

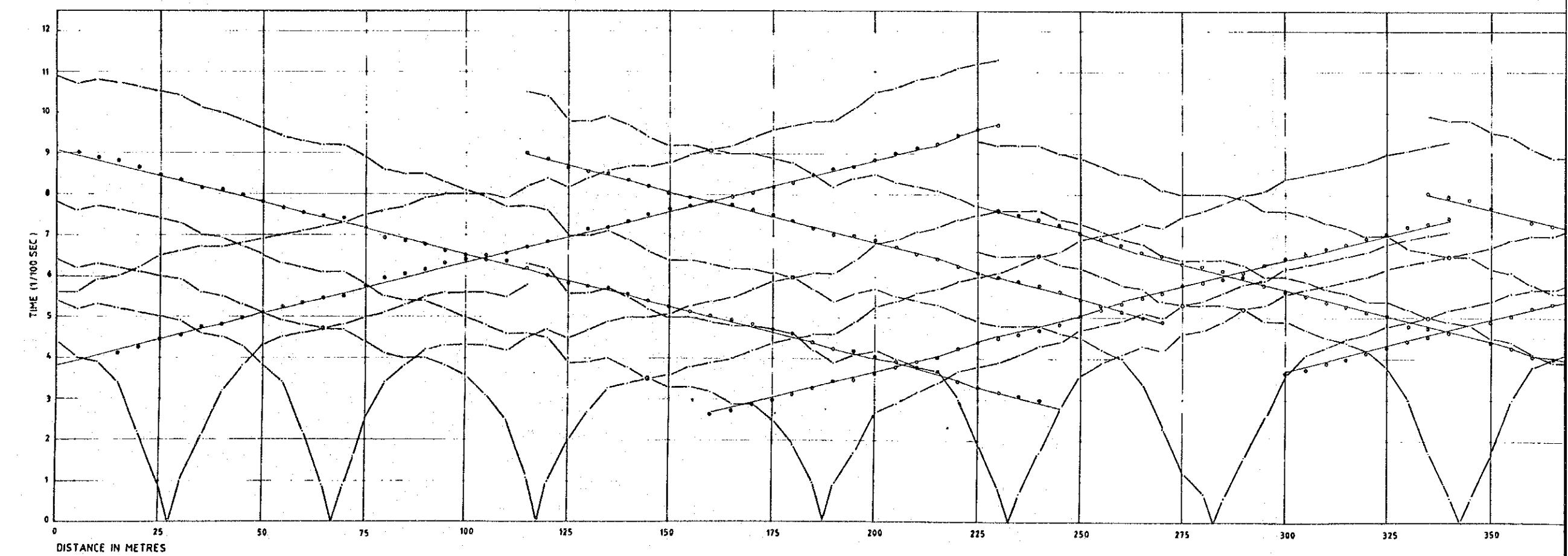

GEOLOGICAL PROFILE OF SADDLE DAMSITE (LINE SS)

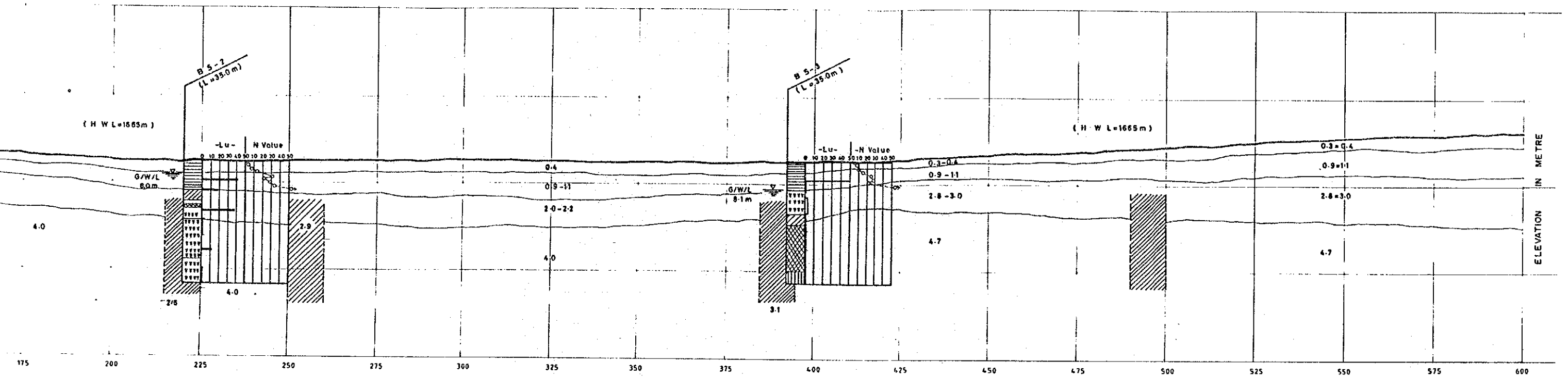

TIME - TRAVEL CURVE OF SADDLE DAMSITE (LINE SS)

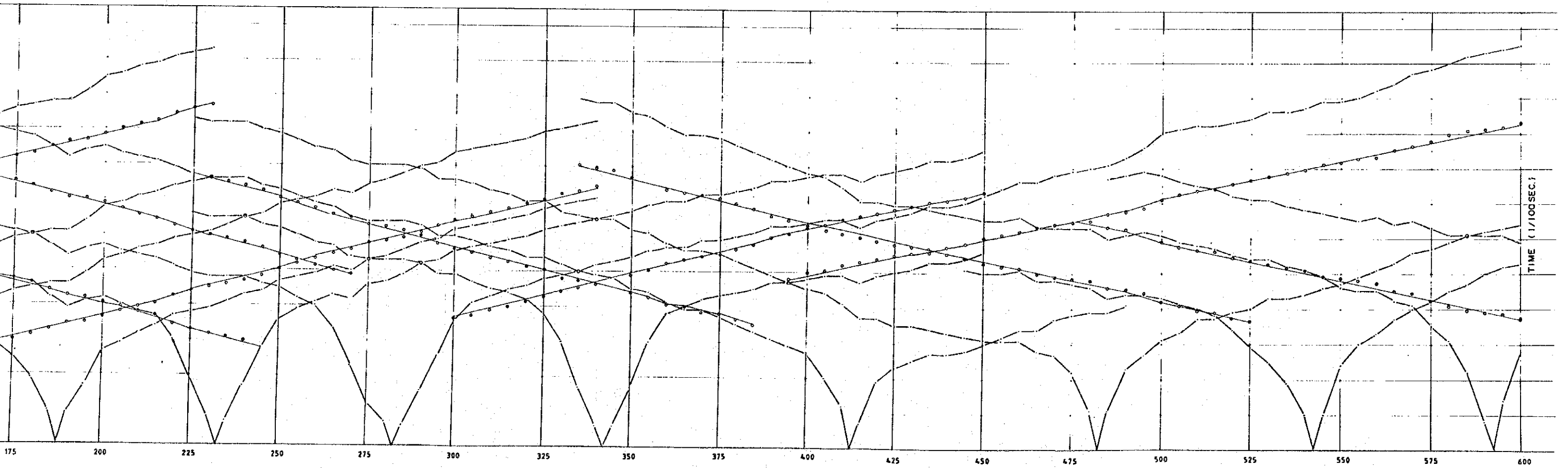

LITHOLOGY IN BORING LOG

- TOP SOIL
- RESIDUAL SOIL/DEBRIS
- RIVER DEPOSITS
- ANDESITE
- TUFF - BRECCIA
- SANDSTONE
- QUARTZITE
- LIME STONE
- DOLERITE

WEATHERING CONDITION OF DRILLED CORE

- COMPLETELY WEATHERED
- WEATHERED
- MODERATELY WEATHERED
- FRACTURED SECTION
- COMPLETELY WEATHERED IN GRANODIORITE
- HEAVILY WEATHERED IN GRANODIORITE

EXPLANATION OF PROFILE

NOTE: G.W./L = GROUND WATER LEVEL AT THE END OF ALL DRILLING WORKS

SEISMIC EXPLORATION
 REPUBLIC OF KENYA
 MAGWAGWA HYDROELECTRIC POWER DEVELOPMENT PROJECT
 JAPAN INTERNATIONAL CO-OPERATION AGENCY
 DATE: NOV. 1990 SHEET 9 OF 16

LINE SW - 2

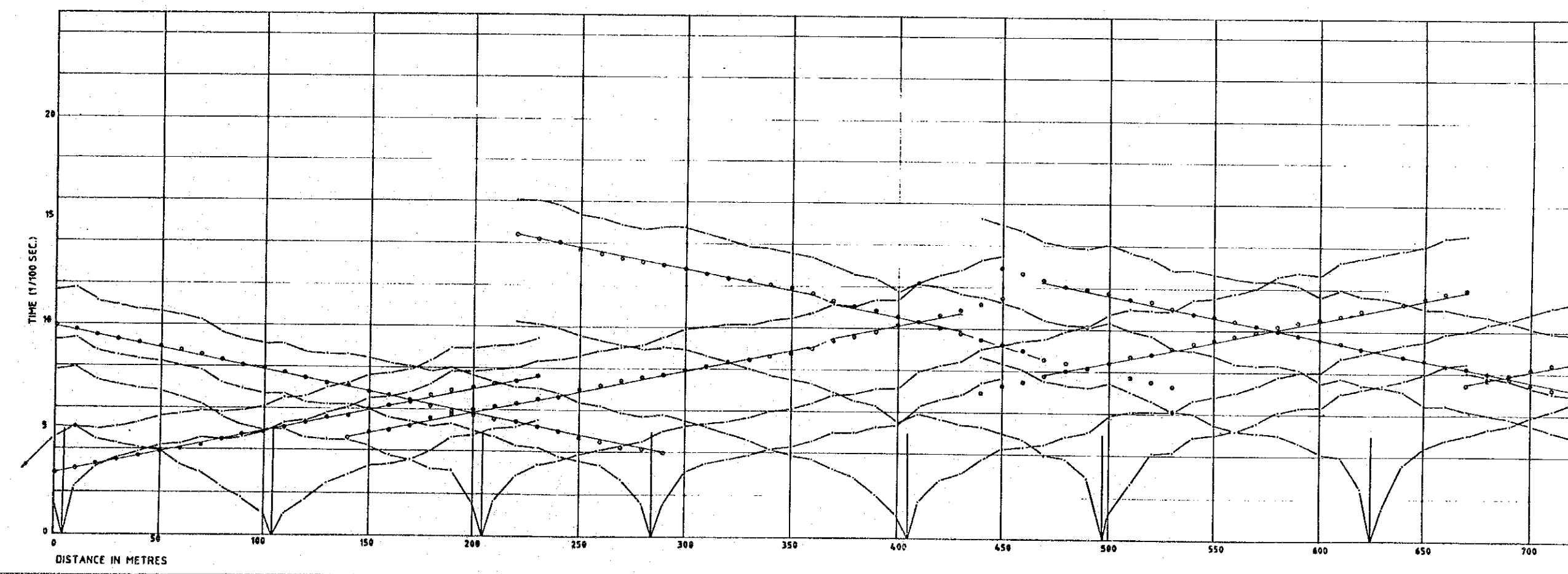
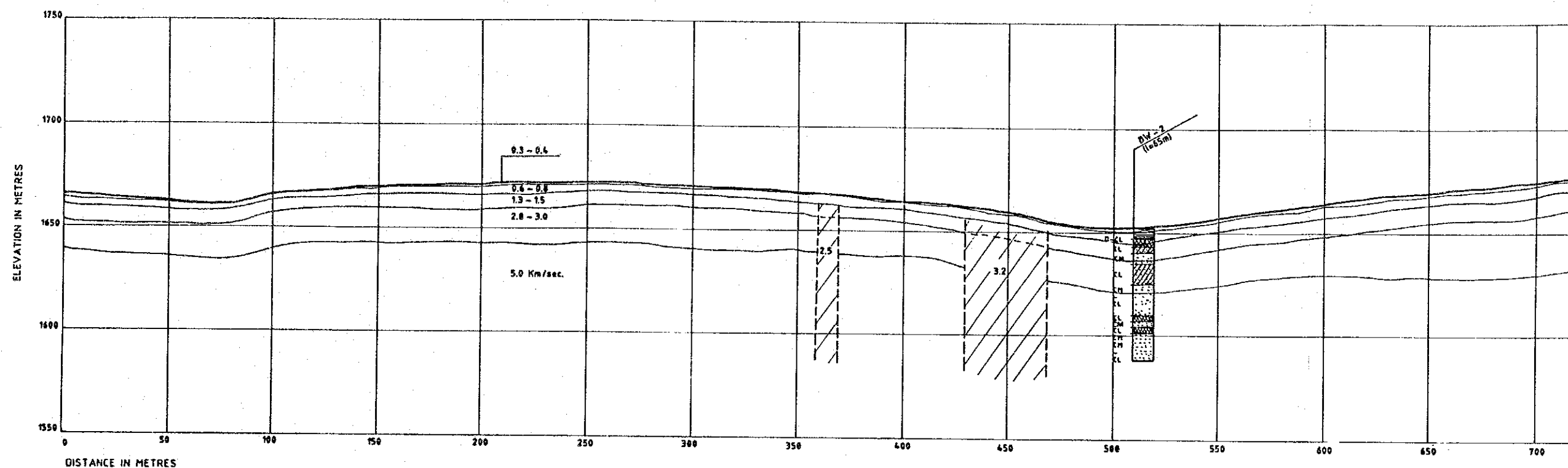

LINE SW - 2

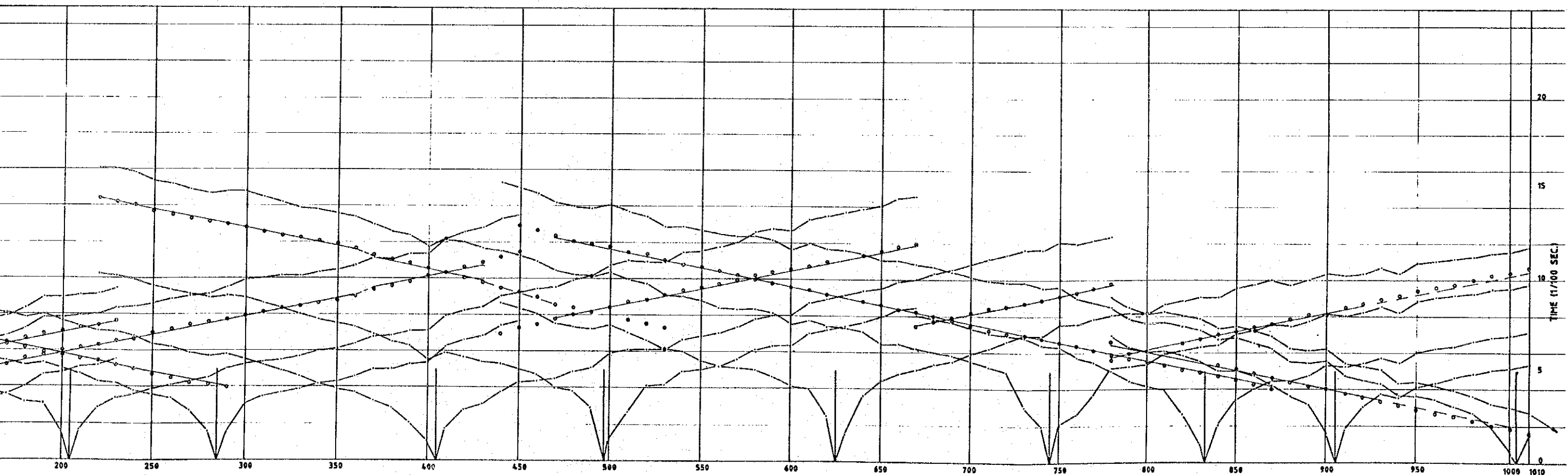
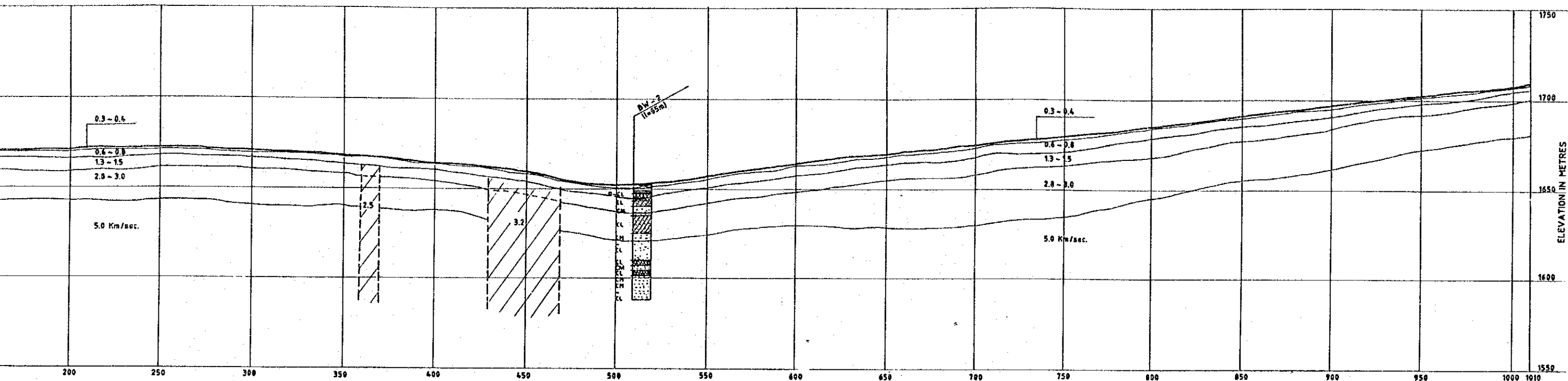

LITHOLOGY IN BORING LOG

- TOP SOIL
- RESIDUAL SOIL / DEBRIS
- RIVER DEPOSITS
- ANDESITE
- TUFF - BRECCIA
- SANDSTONE
- QUARTZITE
- LIME STONE
- DOLERITE

WEATHERING CONDITION OF DRILLED CORE

- COMPLETELY WEATHERED
- WEATHERED
- MODERATELY WEATHERED
- FRACTURED SECTION
- COMPLETELY WEATHERED IN GRANODIORITE
- HEAVILY WEATHERED IN GRANODIORITE

EXPLANATION OF PROFILE

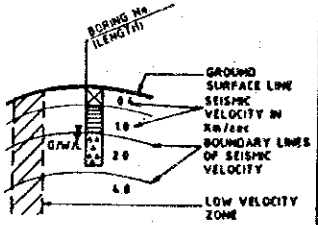

NOTE: G/W/L - GROUND WATER LEVEL AT THE END OF ALL DRILLING WORKS

SEISMIC EXPLORATION







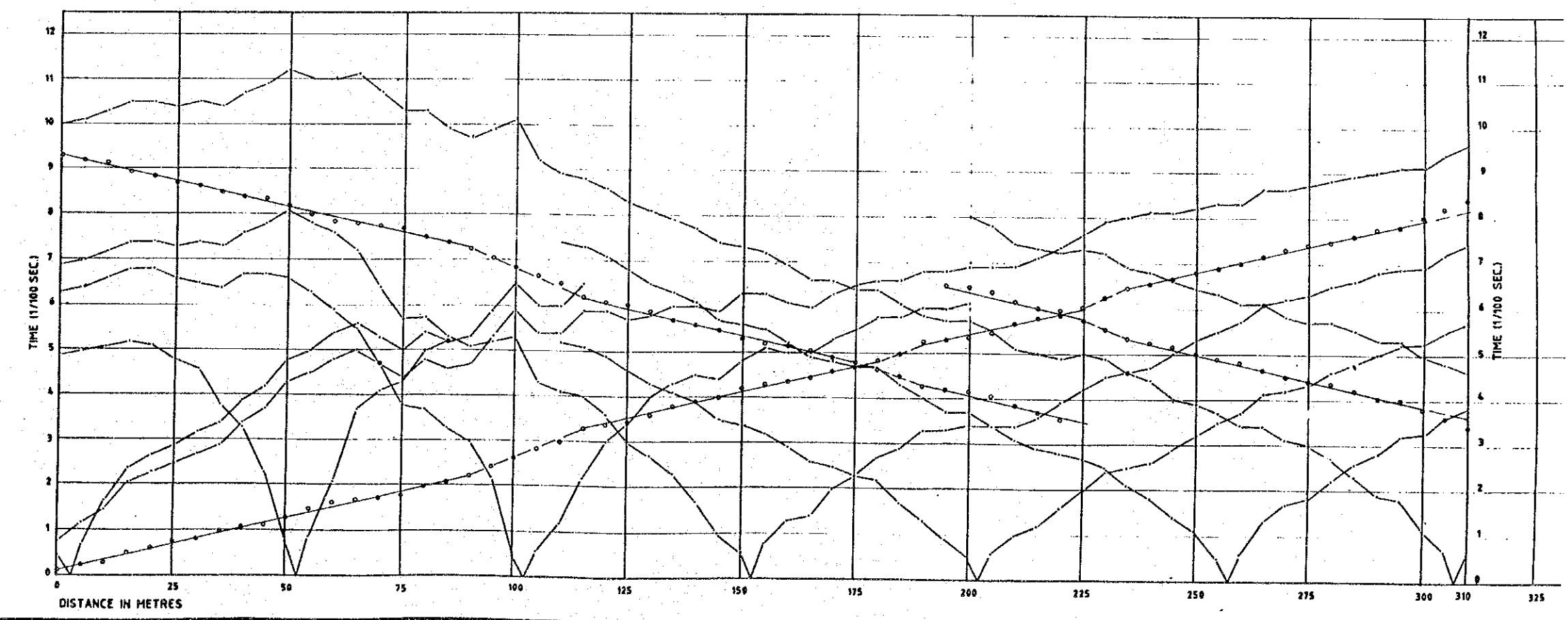
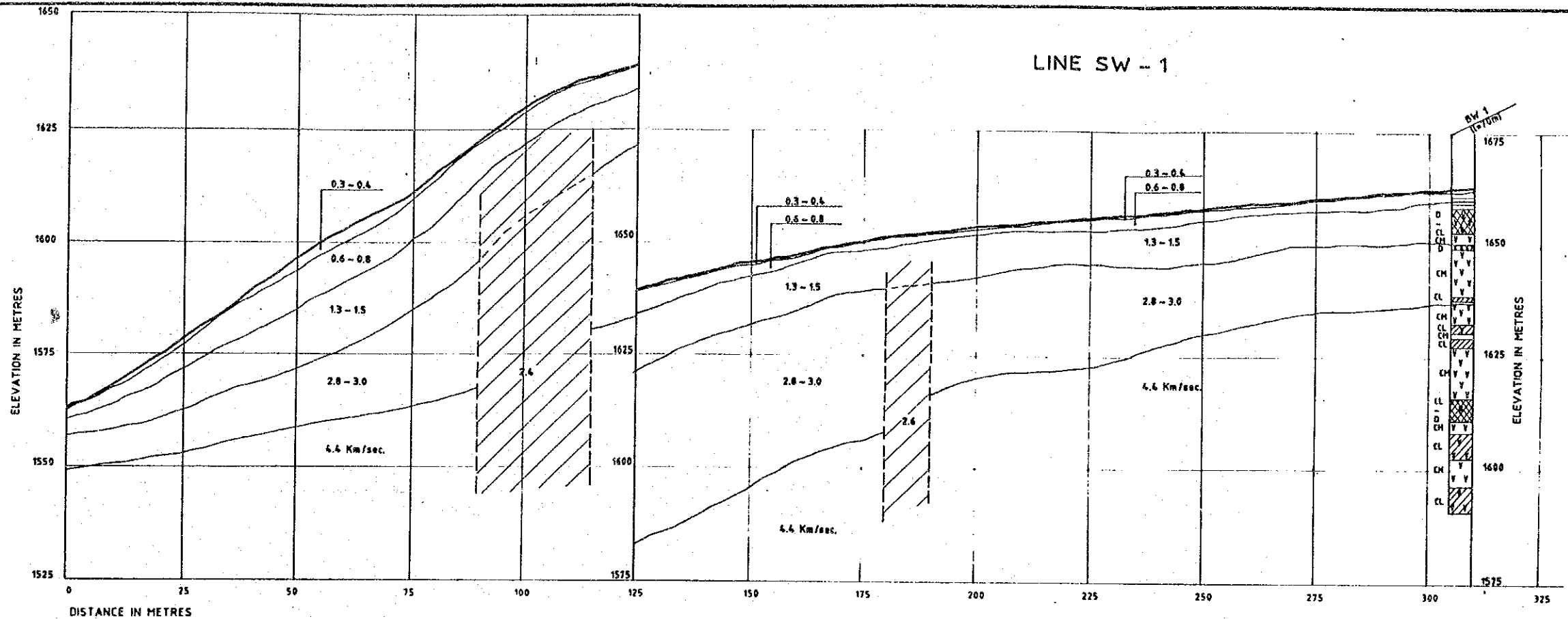

REPUBLIC OF KENYA
MAGWAGWA HYDROELECTRIC POWER DEVELOPMENT PROJECT

JAPAN INTERNATIONAL CO-OPERATION AGENCY







DATE: NOV. 1990 SHEET 8 OF 16



LITHOLOGY IN BORING LOG

-  TOP SOIL
-  RESIDUAL SOIL/DEBRIS
-  RIVER DEPOSITS
-  ANDESITE
-  TUFF - BRECCIA
-  SANDSTONE
-  QUARTZITE
-  LIME STONE
-  DOLERITE

WEATHERING CONDITION OF DRILLED CORE

-  COMPLETELY WEATHERED
-  WEATHERED
-  MODERATELY WEATHERED
-  FRACTURED SECTION
-  COMPLETELY WEATHERED IN GRANODIORITE
-  HEAVILY WEATHERED IN GRANODIORITE

EXPLANATION OF PROFILE

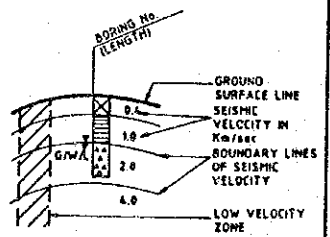

NOTE: G/W/L - GROUND WATER LEVEL AT THE END OF ALL DRILLING WORKS

SEISMIC EXPLORATION

REPUBLIC OF KENYA
MAGWAGWA HYDROELECTRIC POWER DEVELOPMENT PROJECT

JAPAN INTERNATIONAL CO-OPERATION AGENCY

DATE: NOV. 1990 SHEET 10 OF 16



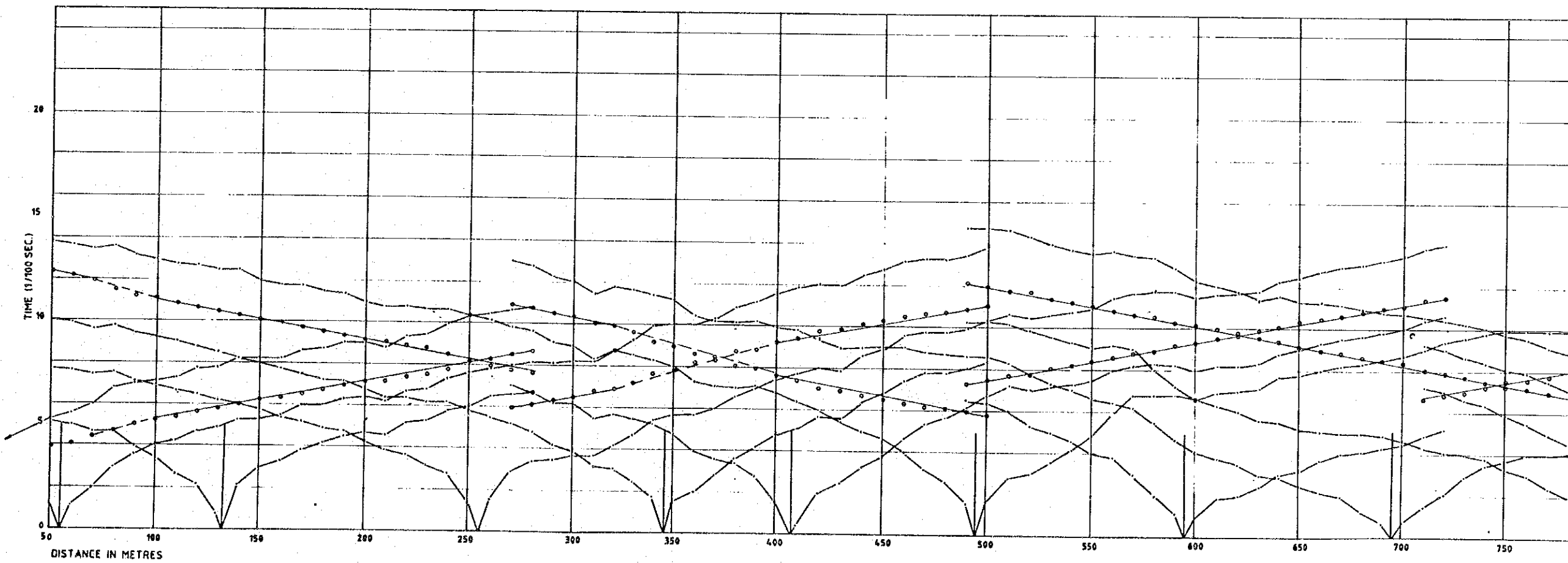
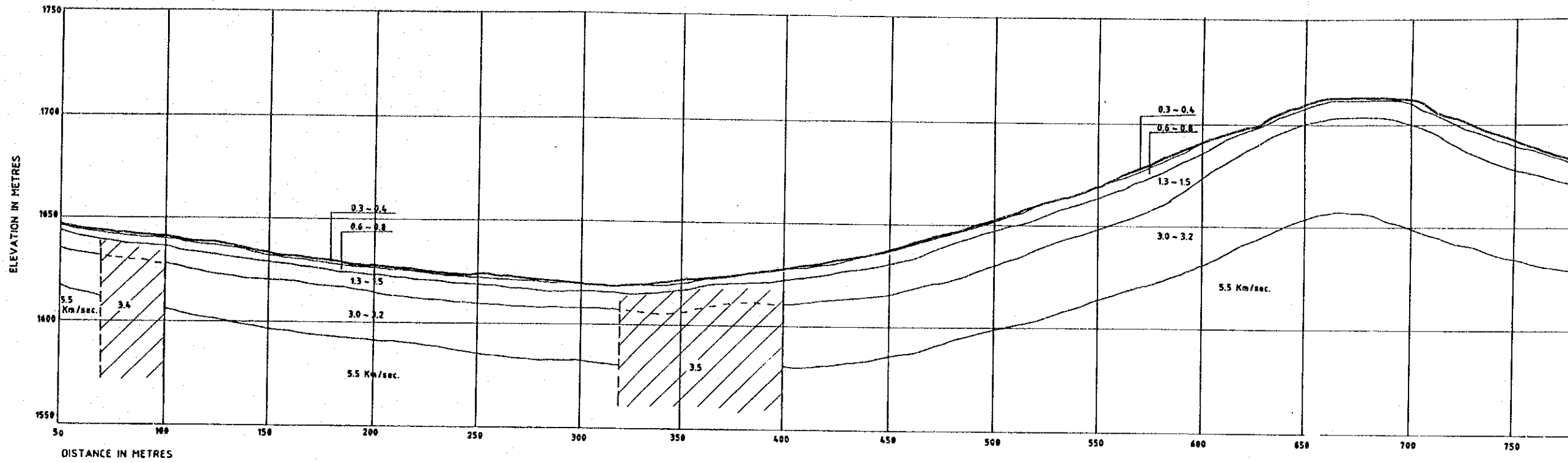



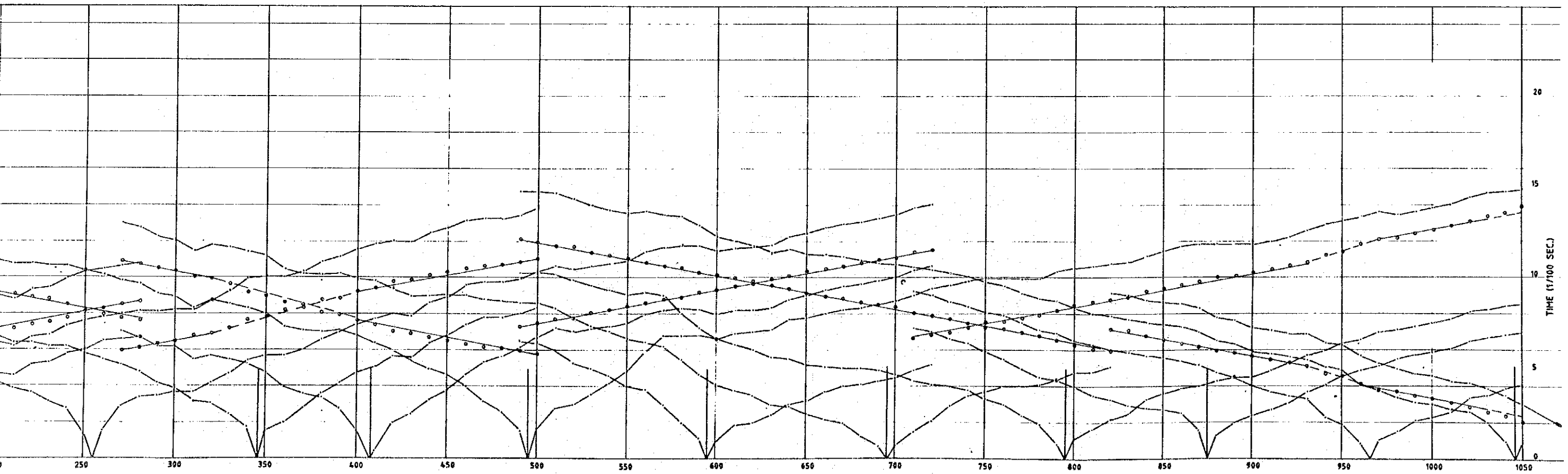
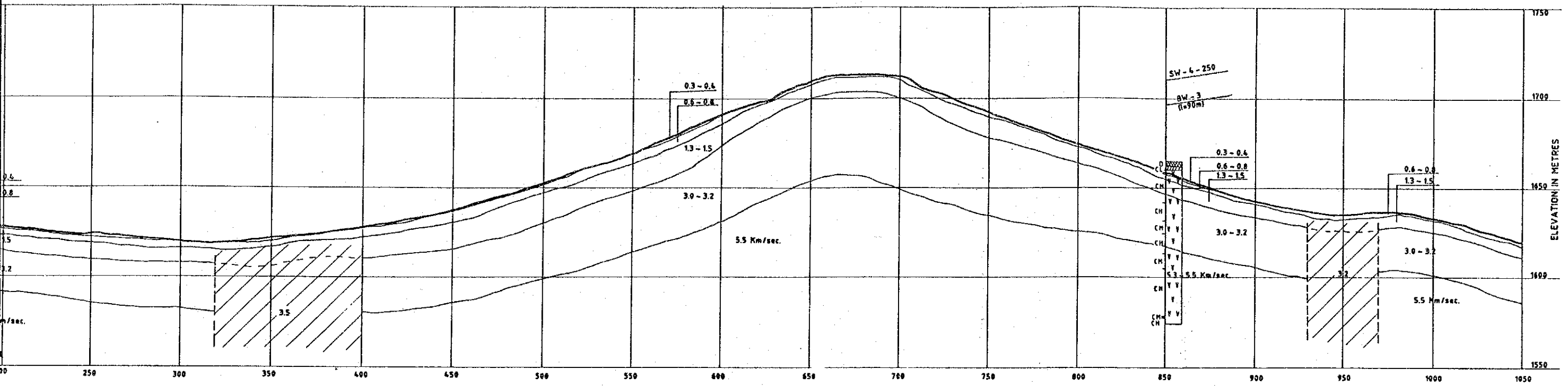

LINE SW - 3









LINE SW - 3



LITHOLOGY IN BORING LOG

-  TOP SOIL
-  RESIDUAL SOIL/DEBRIS
-  RIVER DEPOSITS
-  ANDESITE
-  TUFF - BRECCIA
-  SANDSTONE
-  QUARTZITE
-  LIME STONE
-  GÖLERITE

WEATHERING CONDITION OF DRILLED CORE

-  COMPLETELY WEATHERED
-  WEATHERED
-  MODERATELY WEATHERED
-  FRACTURED SECTION
-  COMPLETELY WEATHERED IN GRANODIORITE
-  HEAVILY WEATHERED IN GRANODIORITE

EXPLANATION OF PROFILE

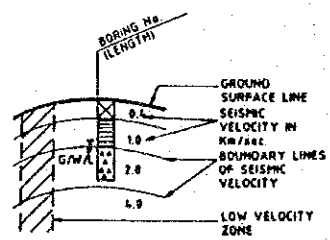

NOTE: G/W/L = GROUND WATER LEVEL AT THE END OF ALL DRILLING WORKS

SEISMIC EXPLORATION

REPUBLIC OF KENYA
MAGWAGWA HYDROELECTRIC
POWER DEVELOPMENT
PROJECT

JAPAN INTERNATIONAL CO-OPERATION AGENCY

DATE: NOV. 1990 SHEET 11 OF 16

LINE SW - 4
SHEET 1 OF 2

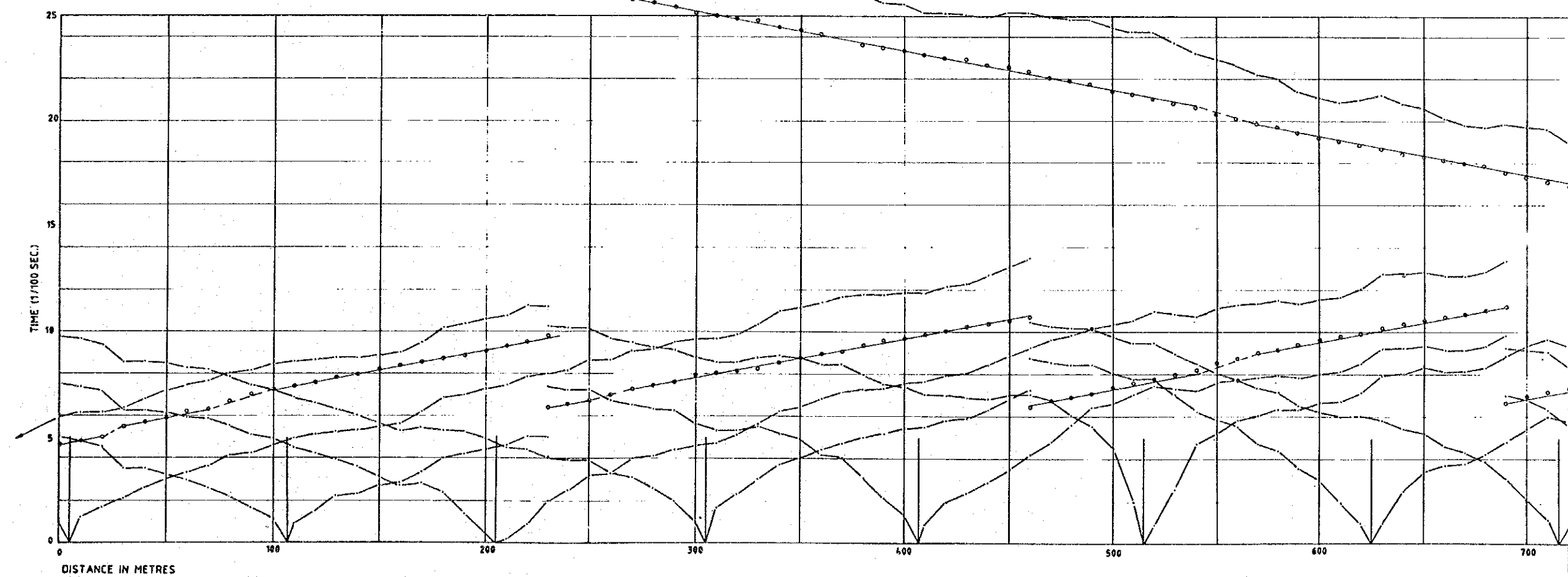
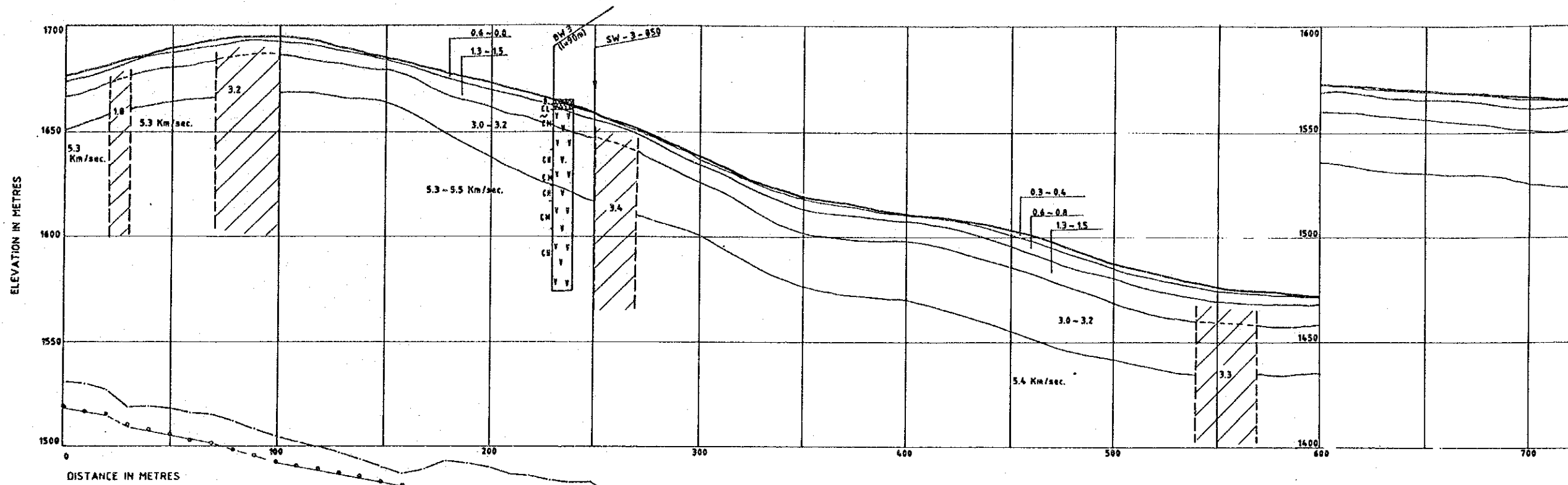



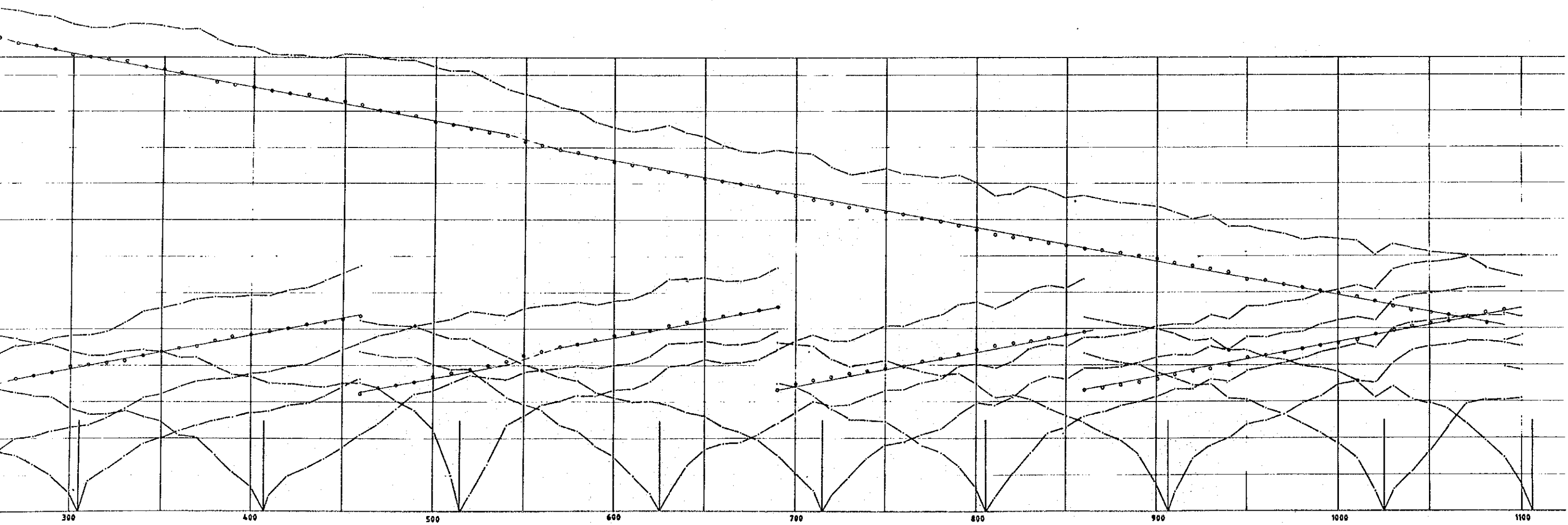
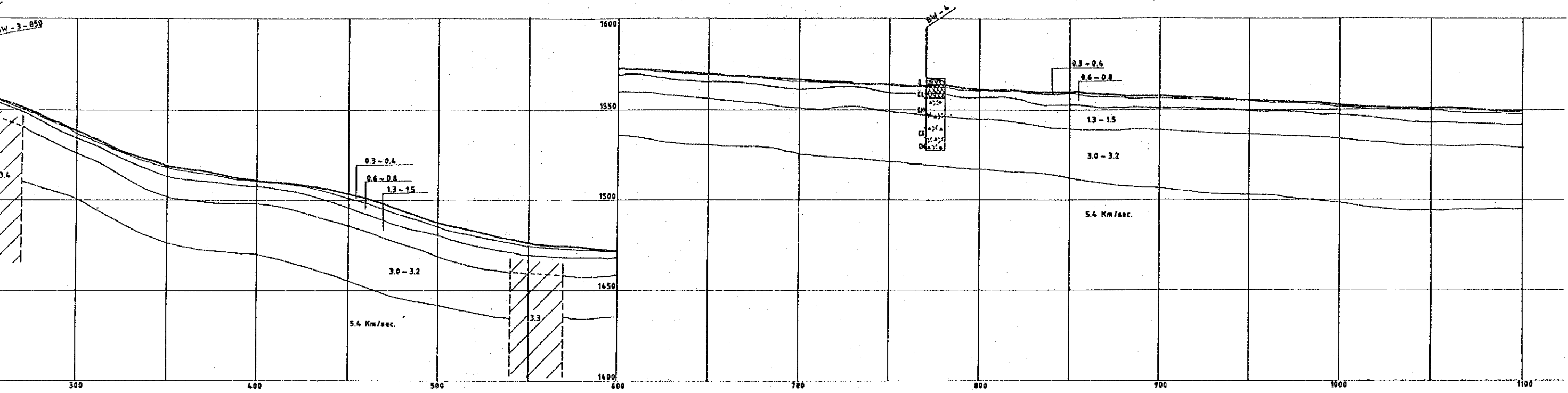





LINE SW - 4
SHEET 1 OF 2









LINE SW - 4
SHEET 2 OF 2

LITHOLOGY IN BORING LOG

-  TOP SOIL
-  RESIDUAL SOIL / DEBRIS
-  RIVER DEPOSITS
-  ANDESITE
-  TUFF - BRECCIA
-  SANDSTONE
-  QUARTZITE
-  LIME STONE
-  GRANITE

WEATHERING CONDITION OF DRILLED CORE

-  COMPLETELY WEATHERED
-  WEATHERED
-  MODERATELY WEATHERED
-  FRACTURED SECTION
-  COMPLETELY WEATHERED IN GRANODIORITE
-  HEAVILY WEATHERED IN GRANODIORITE

EXPLANATION OF PROFILE

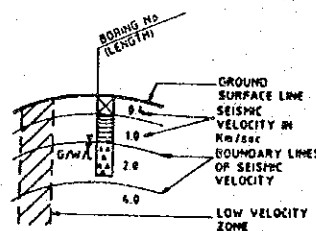

NOTE: G/W/L = GROUND WATER LEVEL AT THE END OF ALL DRILLING WORKS

SEISMIC EXPLORATION

REPUBLIC OF KENYA

MAGWAGWA HYDROELECTRIC
POWER DEVELOPMENT
PROJECT

JAPAN INTERNATIONAL CO-OPERATION AGENCY

DATE: NOV. 1990 SHEET 12 OF 16

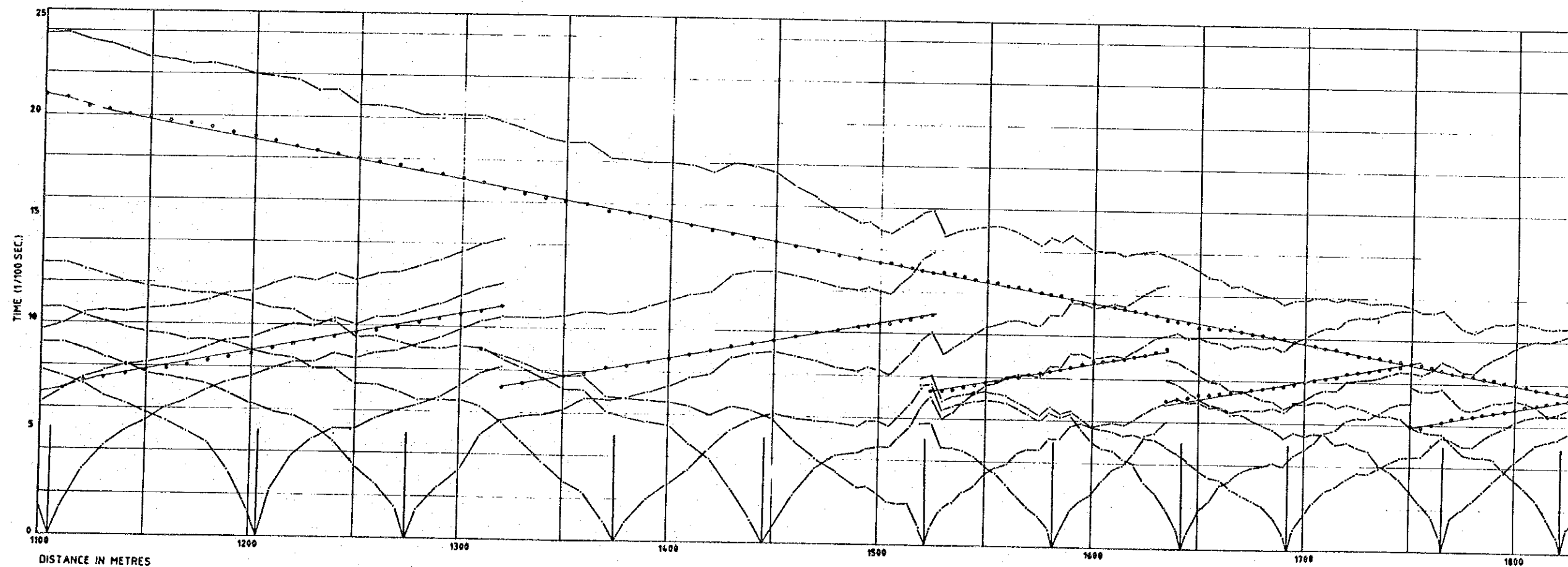
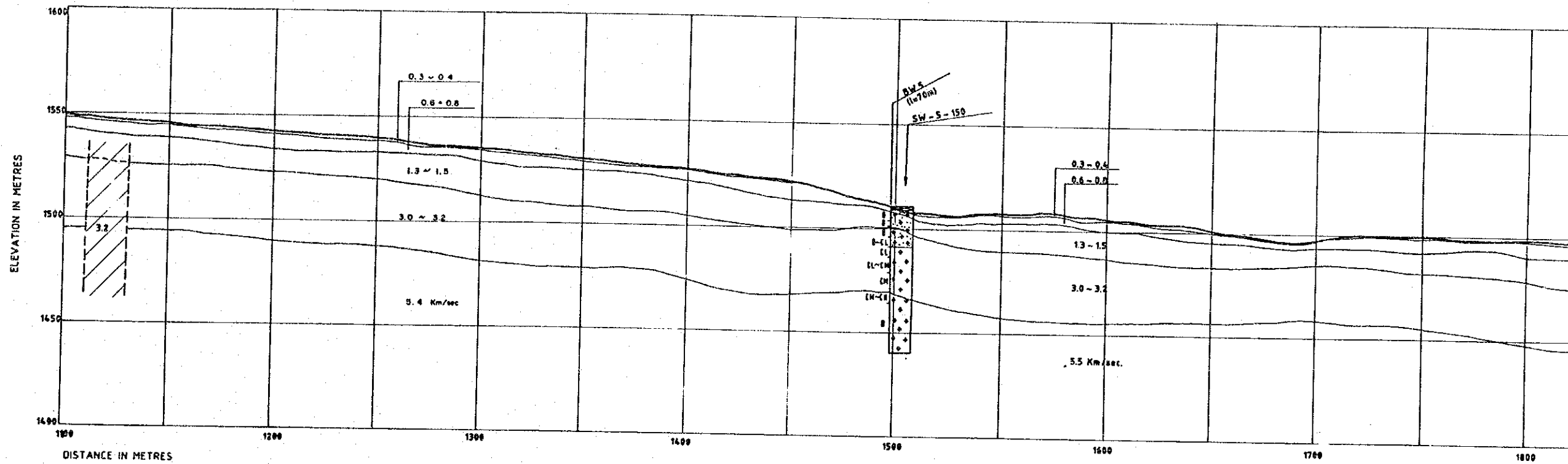



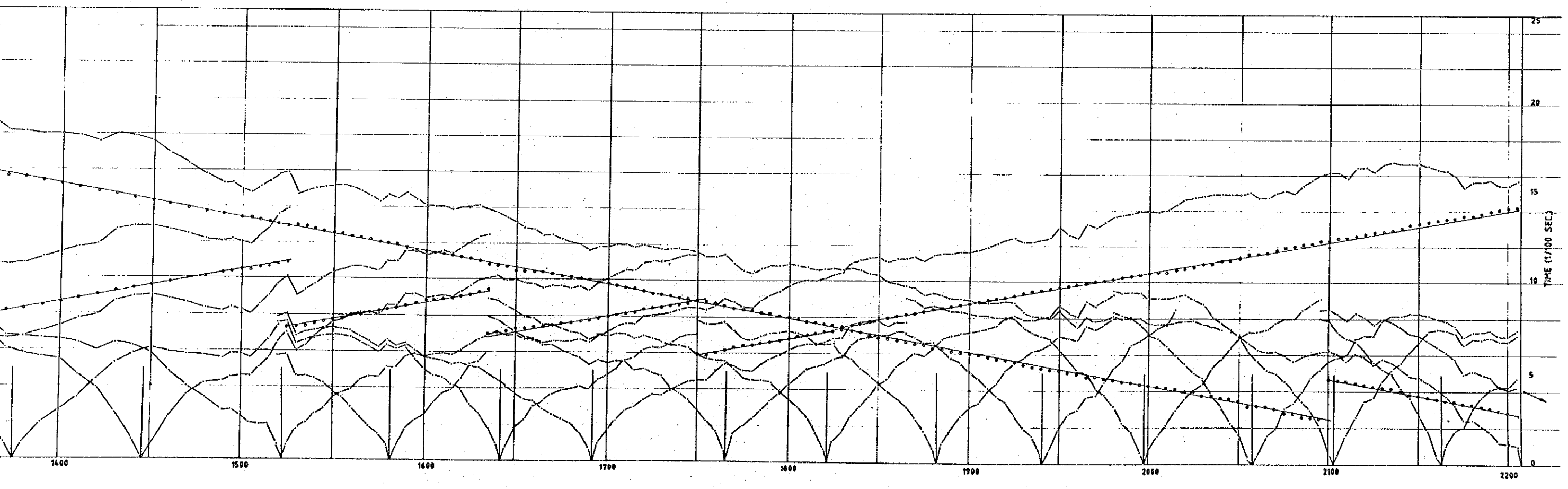
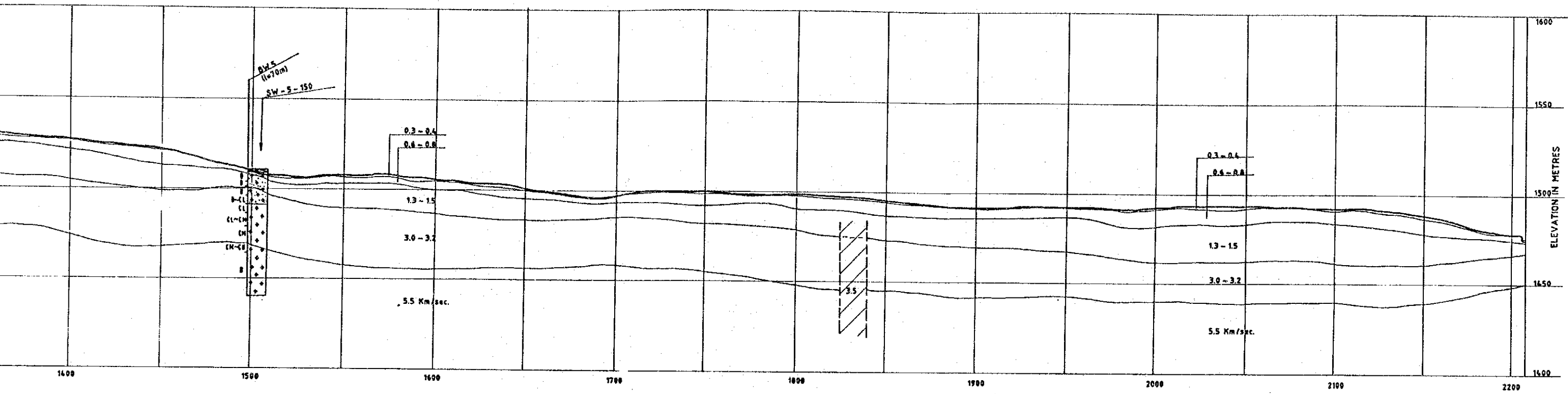





LINE SW - 4
SHEET 2 OF 2









LINE SW - 5

LITHOLOGY IN BORING LOG

-  TOP SOIL
-  RESIDUAL SOIL/DEBRIS
-  RIVER DEPOSITS
-  ANDESITE
-  TUFF - BRECCIA
-  SANDSTONE
-  QUARTZITE
-  LIME STONE
-  DOLERITE

WEATHERING CONDITION OF DRILLED CORE

-  COMPLETELY WEATHERED
-  WEATHERED
-  MODERATELY WEATHERED
-  FRACTURED SECTION
-  COMPLETELY WEATHERED IN GRANODIORITE
-  HEAVILY WEATHERED IN GRANODIORITE

EXPLANATION OF PROFILE

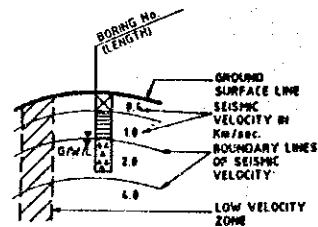

NOTE: B/W/L - GROUND WATER LEVEL AT THE END OF ALL DRILLING WORKS.

SEISMIC EXPLORATION







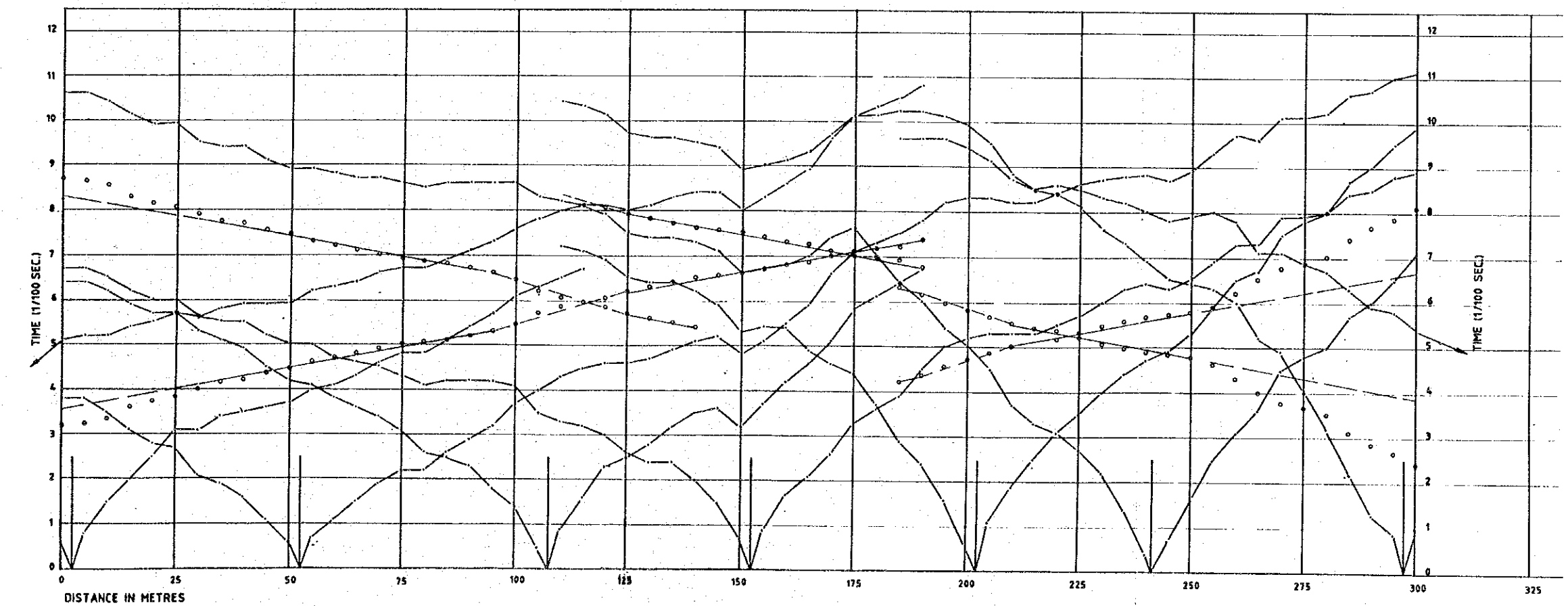
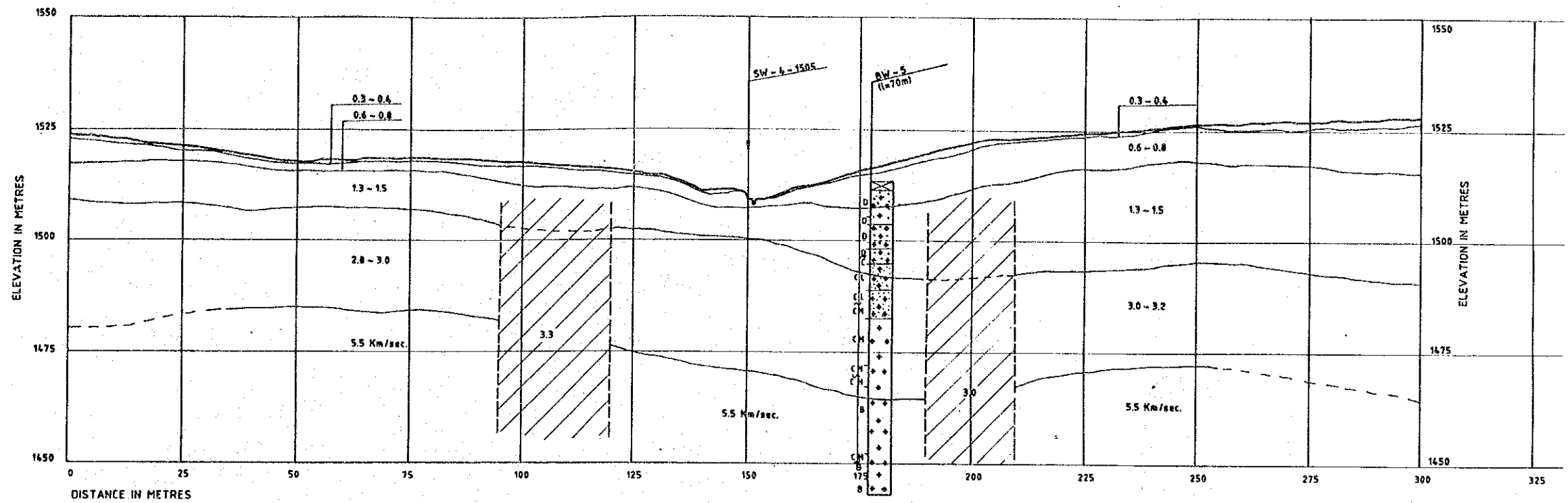

REPUBLIC OF KENYA
MAGWAGWA HYDROELECTRIC
POWER DEVELOPMENT
PROJECT

JAPAN INTERNATIONAL CO-OPERATION AGENCY







DATE: NOV. 1990 SHEET 13 OF 16



LITHOLOGY IN BORING LOG

-  TOP SOIL
-  RESIDUAL SOIL/DEBRIS
-  RIVER DEPOSITS
-  ANDESITE
-  TUFF - BRECCIA
-  SANDSTONE
-  QUARTZITE
-  LIME STONE
-  DOLERITE

WEATHERING CONDITION OF DRILLED CORE

-  COMPLETELY WEATHERED
-  WEATHERED
-  MODERATELY WEATHERED
-  FRACTURED SECTION
-  COMPLETELY WEATHERED IN GRANODIORITE
-  HEAVILY WEATHERED IN GRANODIORITE

EXPLANATION OF PROFILE

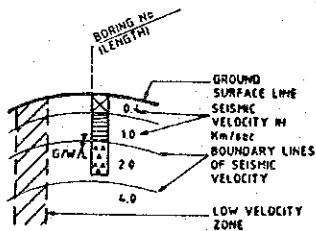

NOTE: G.W.L. = GROUND WATER LEVEL AT THE END OF ALL DRILLING WORKS

SEISMIC EXPLORATION

REPUBLIC OF KENYA

MAGWAGWA HYDROELECTRIC POWER DEVELOPMENT PROJECT

JAPAN INTERNATIONAL CO-OPERATION AGENCY

DATE: NOV. 1990 SHEET 14 OF 16

LINE SQ - 1

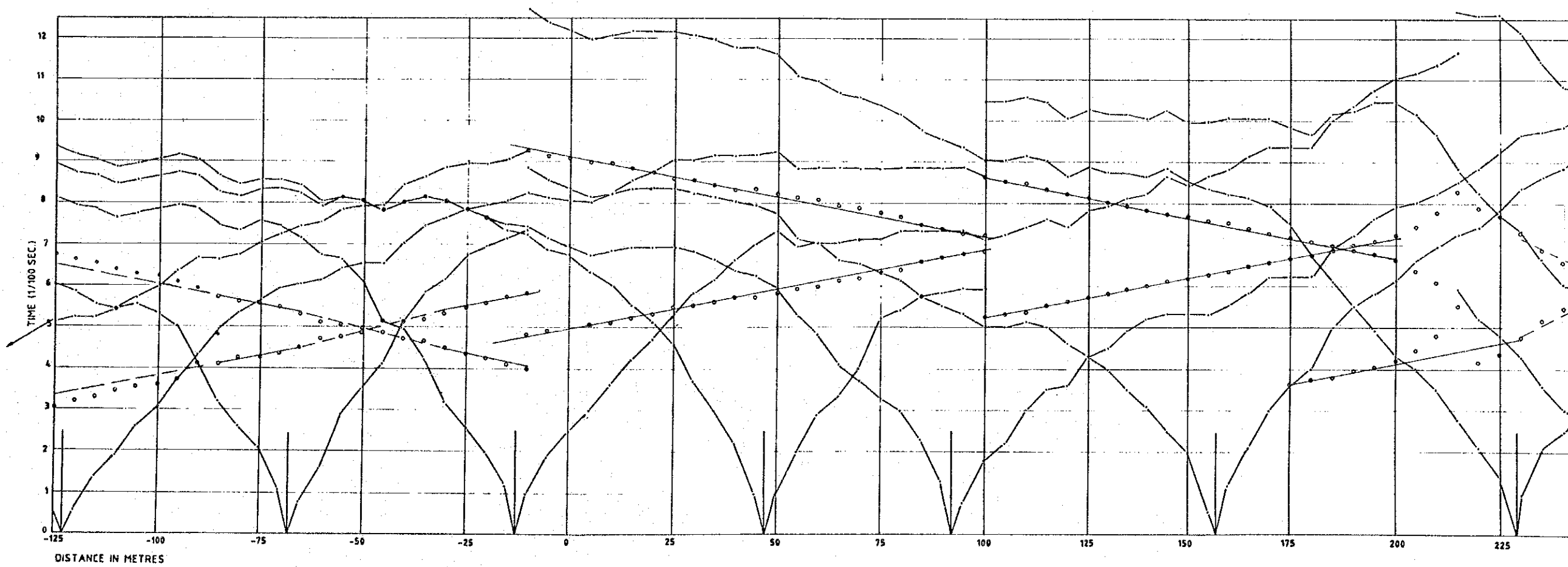
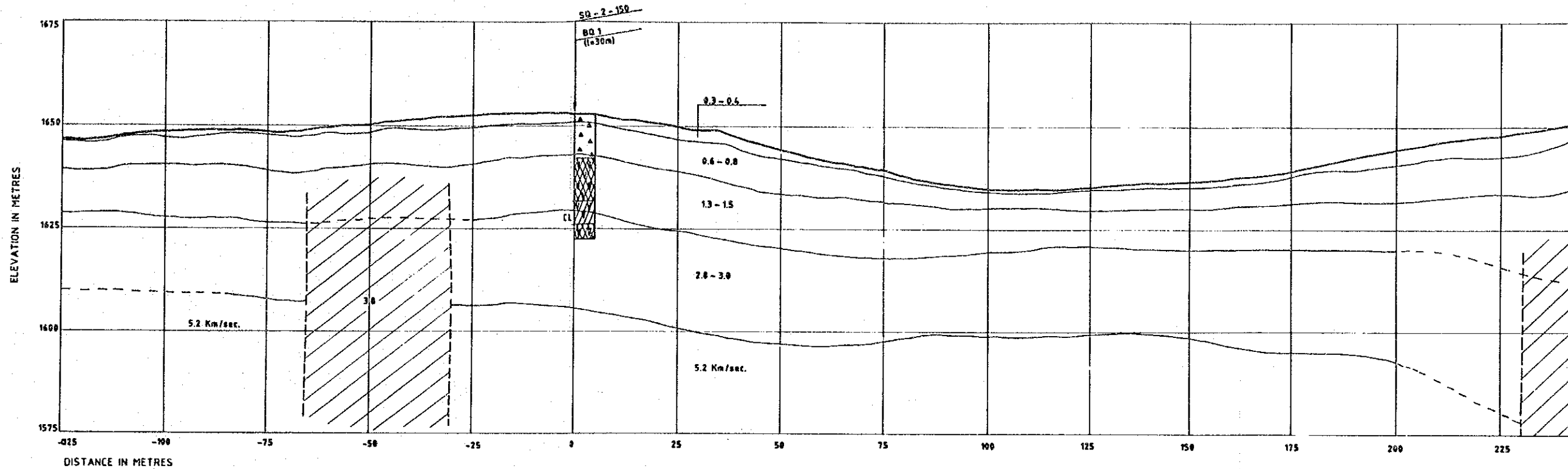

LINE SQ - 1

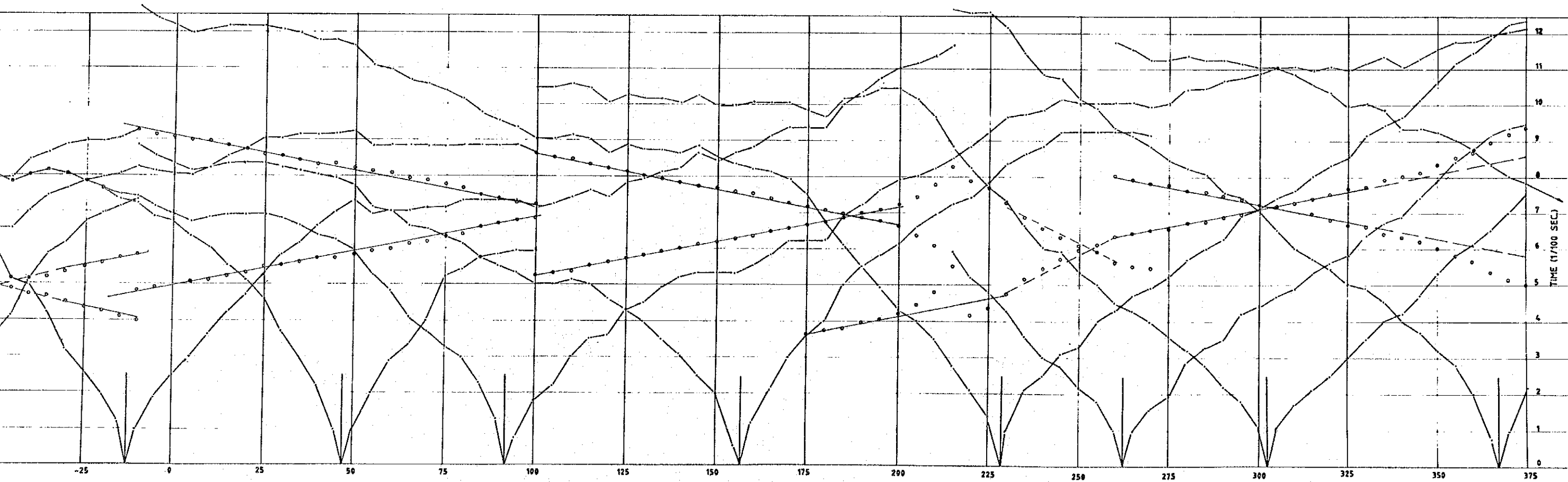
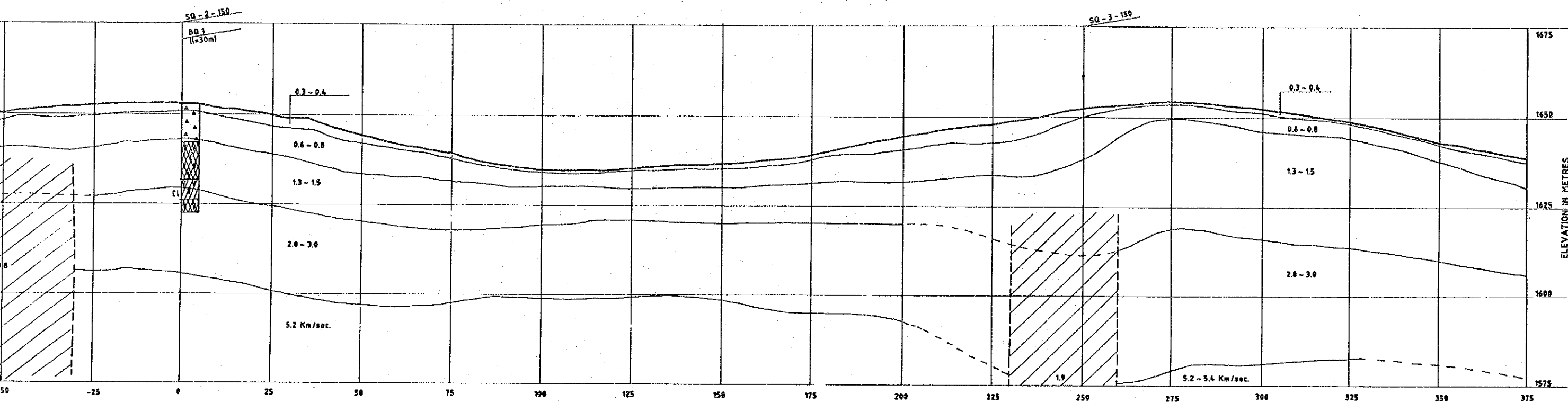

LITHOLOGY IN BORING LOG

- TOP SOIL
- RESIDUAL SOIL/DEBRIS
- RIVER DEPOSITS
- ANDESITE
- TUFF - BRECCIA
- SANDSTONE
- QUARTZITE
- LIME STONE
- DOLERITE

WEATHERING CONDITION OF DRILLED CORE

- COMPLETELY WEATHERED
- WEATHERED
- MODERATELY WEATHERED
- FRACTURED SECTION
- COMPLETELY WEATHERED IN GRANODIORITE
- HEAVILY WEATHERED IN GRANODIORITE

EXPLANATION OF PROFILE

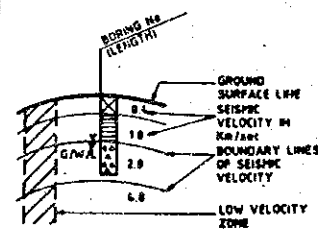

NOTE: G/W.L. = GROUND WATER LEVEL AT THE END OF ALL DRILLING WORKS

SEISMIC EXPLORATION

REPUBLIC OF KENYA
MAGWAGWA HYDROELECTRIC
POWER DEVELOPMENT
PROJECT







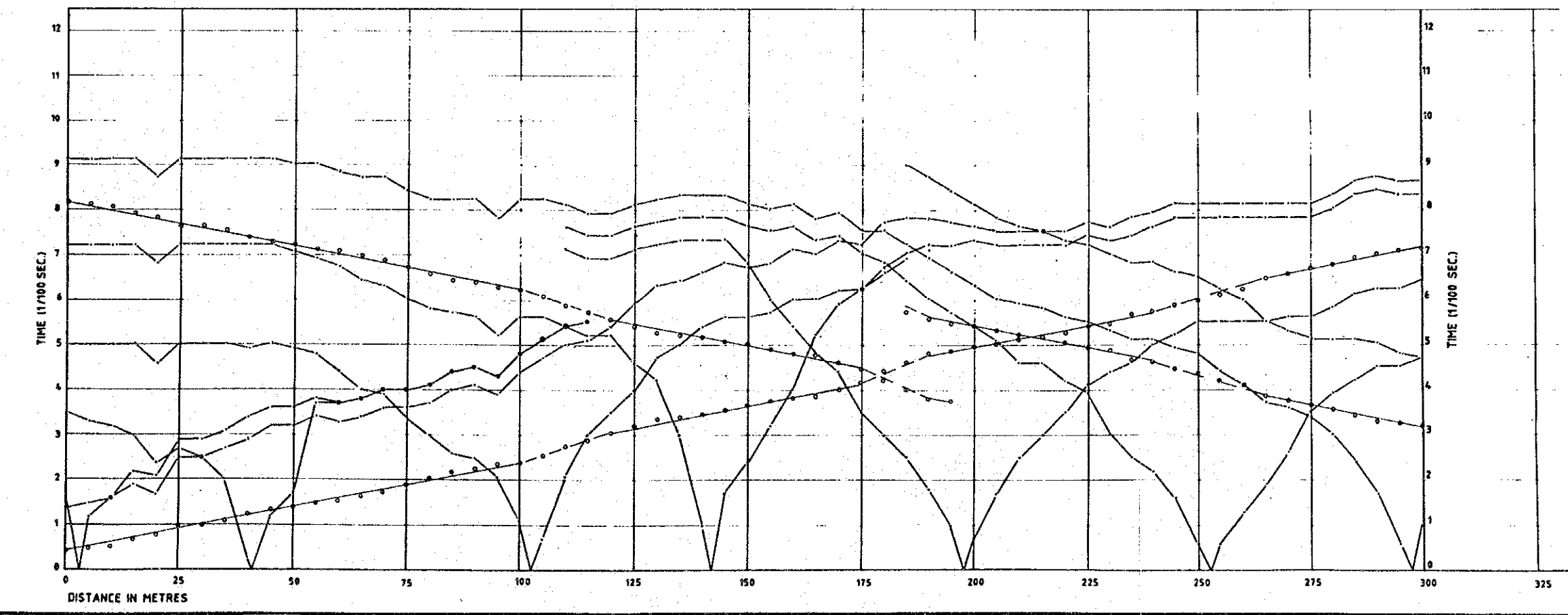
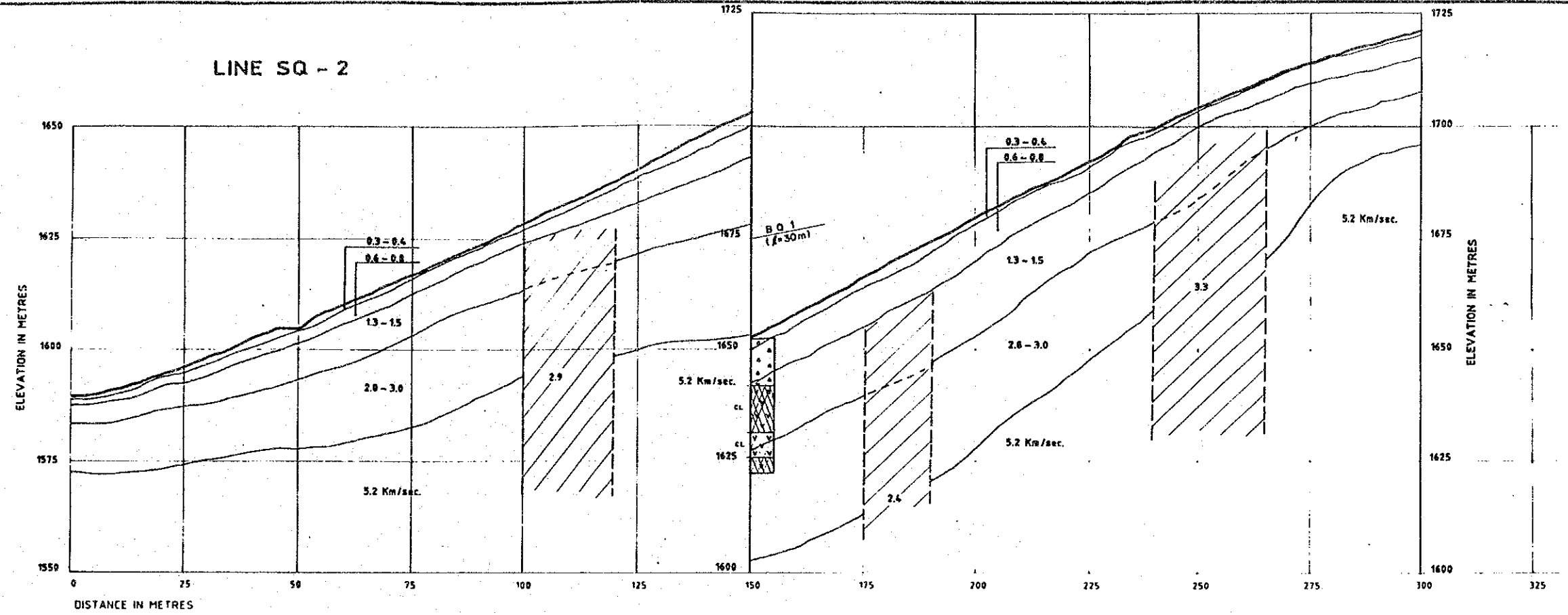

JAPAN INTERNATIONAL CO-OPERATION AGENCY

DATE: NOV. 1998 SHEET 15 OF 16







LINE SQ - 2



LITHOLOGY IN BORING LOG

-  TOP SOIL
-  RESIDUAL SOIL/DEBRIS
-  RIVER DEPOSITS
-  ANDESITE
-  TUFF - BRECCIA
-  SANDSTONE
-  QUARTZITE
-  LIME STONE
-  DOLERITE

WEATHERING CONDITION OF DRILLED CORE

-  COMPLETELY WEATHERED
-  WEATHERED
-  MODERATELY WEATHERED
-  FRACTURED SECTION
-  COMPLETELY WEATHERED IN GRANODIORITE
-  HEAVILY WEATHERED IN GRANODIORITE

EXPLANATION OF PROFILE

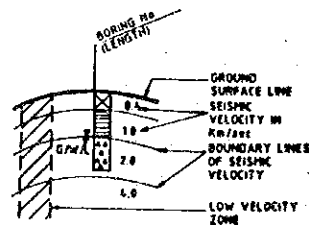

NOTE: G/W/L = GROUND WATER LEVEL AT THE END OF ALL DRILLING WORKS

SEISMIC EXPLORATION

REPUBLIC OF KENYA
MAGWAGWA HYDROELECTRIC
POWER DEVELOPMENT
PROJECT

JAPAN INTERNATIONAL CO-OPERATION AGENCY

DATE: NOV. 1990 SHEET 16 OF 16

LINE SQ - 3

