

THE DETAILED DESIGN STUDY ON
AREA TRAFFIC CONTROL PROJECT IN BANGKOK
IN THE KINGDOM OF THAILAND

SUPPLEMENTARY VOLUME

PART 4

DRAFT GENERAL DESIGN PLANS

FINAL REPORT

OCTOBER 1990

JAPAN INTERNATIONAL COOPERATION AGENCY

L122
71
SSF

SSF

90-106(6/11)

JICA LIBRARY



1092833(1)

22743

THE DETAILED DESIGN STUDY ON
AREA TRAFFIC CONTROL PROJECT IN BANGKOK
IN THE KINGDOM OF THAILAND

SUPPLEMENTARY VOLUME

PART 4

DRAFT GENERAL DESIGN PLANS

FINAL REPORT

OCTOBER 1990

JAPAN INTERNATIONAL COOPERATION AGENCY



国際協力事業団

22743

PART I: SCHEDULE OF DRAWINGS

**VOLUME 1
GENERAL DESIGN PLANS**

This "Volume 1 : General Design Plan" contains the general design plans as the supplement to Part G : Technical Specification of the Tender Document.

The tenderers should refer to this volume when proposing, designing and installing the Bangkok ATC System-Stage I, if detailed requirements and explanations are not specified in the Technical Specification.

Drawings in this volume are organized according to the corresponding division in the Technical Specification as:

Division I : General Requirements--Plans No. 1224-1228

Division II : Traffic Signal System--Plans No. 1201-1223

Division III : Closed Circuit Television System--Plans No. 1301-1303

Division IV : Control Center and Storage Yard--Plans No. 1401-1411

*Note: Tenderers should note that any specifications that may have been shown as "PVC" in the drawings for field installation shall read as "Steel" instead. !

LIST OF DRAWINGS

Page No.	Drawing No.	Title
1	1201	Traffic Signal Locations
2	1202	Traffic Signal System Configuration Diagram
3	1203	Suggested Sub-areas for Signal System
4	1204	Menu Tree of Work Station
5	1205	Traffic Condition Monitoring Wallmap
6	1206-1	Area Covered within Wallmap
7	1206-2	Enlarged Stage I Area of Drawing No.1206-1
8	1207	Equipment Monitoring Wallmap
9	1208	Control Desk
10	1209	Image of Manual Control Panel
11	1210	Mounting facility of Local controller
12	1211	Traffic Signal Poles and Footing Type A
13	1212	Traffic Signal Poles and Footing Type B
14	1213	N.A.
15	1214	N.A.
16	1215	Signal & Detector Foundation
17	1216	Detector Locations
18	1217	Loop Coil Detector Installation Plan
19	1218	Mounting Facility of Detector Cabinet Type 1
20	1219	Mounting Facility of Detector Cabinet Type 2
21	1220	Mounting Facility of Detector Cabinet Type 3
22	1221	Ultrasonic Detector Installation Plan
23	1222	Mounting Facility of Detector Cabinet Type 4
24	1223	Mounting Facility of Detector Cabinet Type 5
25	1224	Grounding System for Local Controller and Detector Cabinet

Page No.	Drawing No.	Title
26	1225	Underground Conduit Installalon Plan
27	1226	Aerial-Underground Cable Connection Details
28	1227	Handhole Design Type C
29	1228	Handhole Design Type D
30	1301	CCTV System Configuration Diagram
31	1302	CCTV Camera Locations
32	1303	CCTV Camera Installation Plan
33	1401	Traffic Control Center Location and Key Plan
34	1402	Finish Schedule
35	1403	Plan of Traffic Control Center
36	1404	Sections and Details of Traffic Control Center
37	1405	Power Supply Room and Generator Room
38	1406	Fire Fighting Facilities
39	1407	Power Feeder Facilities
40	1408	Lighting Facilities
41	1409	Power Outlet and Telephone Facilities
42	1410	Air Conditioning and Ventilation/Others
43	1411	Air Conditioning and Ventilation Facilities



LEGEND

TRAFFIC SIGNAL UNDER STAGE I ATC SYSTEM

- INTERSECTION NO.
- ⑨ SIGNAL IN THE EXISTING ATC SYSTEM
 - ⑤1 EXISTING ISOLATED SIGNAL
 - ②5 PLANNED SIGNAL TO BE INSTALLED
 - △ P1 PEDESTRIAN CROSSING SIGNAL

TRAFFIC SIGNAL OUTSIDE OF STAGE I ATC SYSTEM

- INTERSECTION NO.
- 61

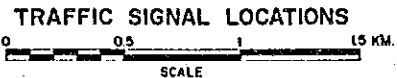

				BANGKOK AREA TRAFFIC CONTROL SYSTEM PROJECT : STAGE I			
				Submitted By : Jiro Kodera JICA Study Team Leader		Approved By : Boonwat Tiplas BMA Study Team Leader	
				Designed By : Yasuo Nabeshima JICA Study Member		Checked By : TED, BMA	
Code	Revision	Date	Initial	JICA Japan International Cooperation Agency		Scale 1/15,000	
Associated Plan No. :						BMA Bangkok Metropolitan Administration	
				Date SEPTEMBER '90		Total 1/43	

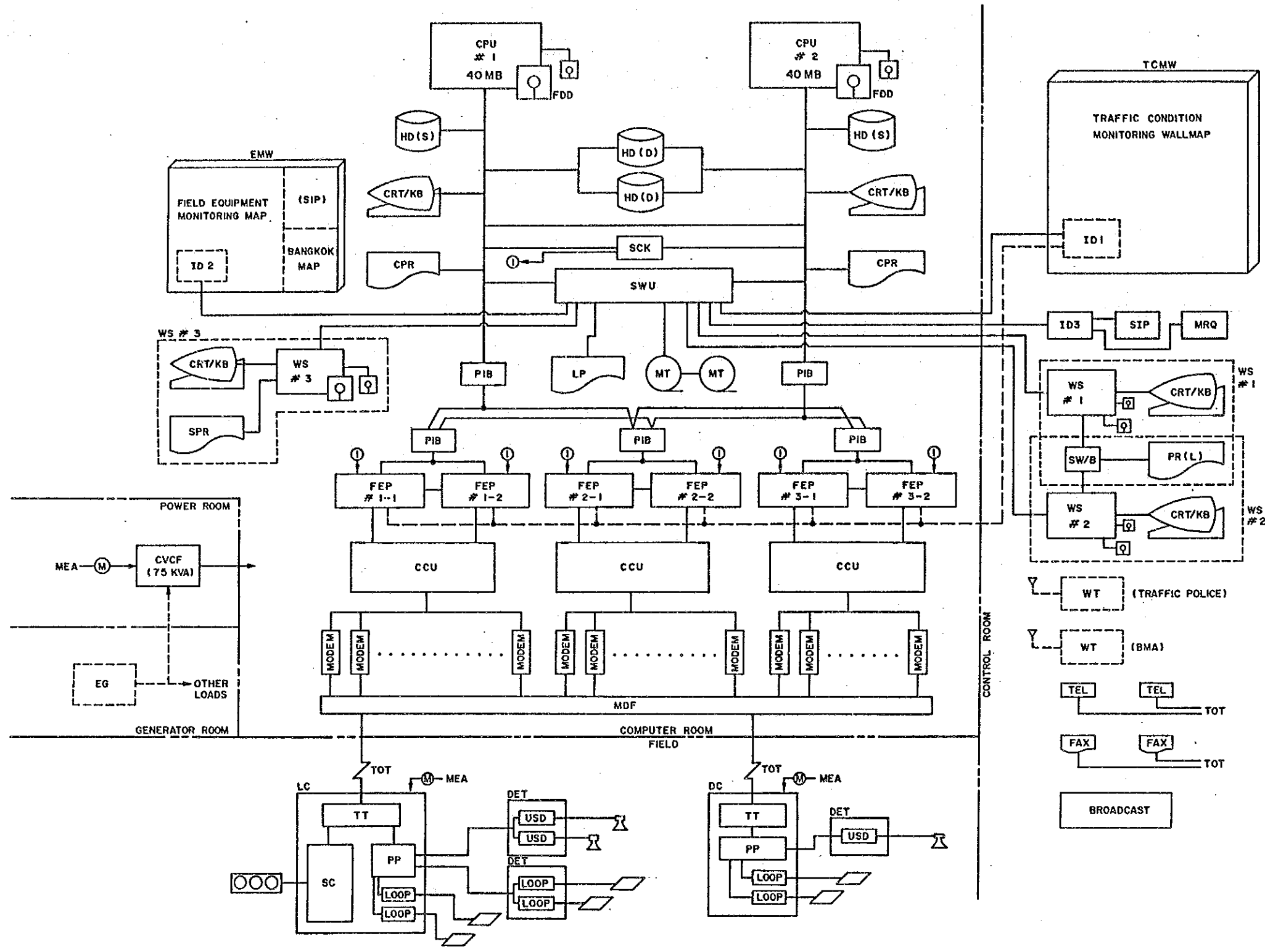



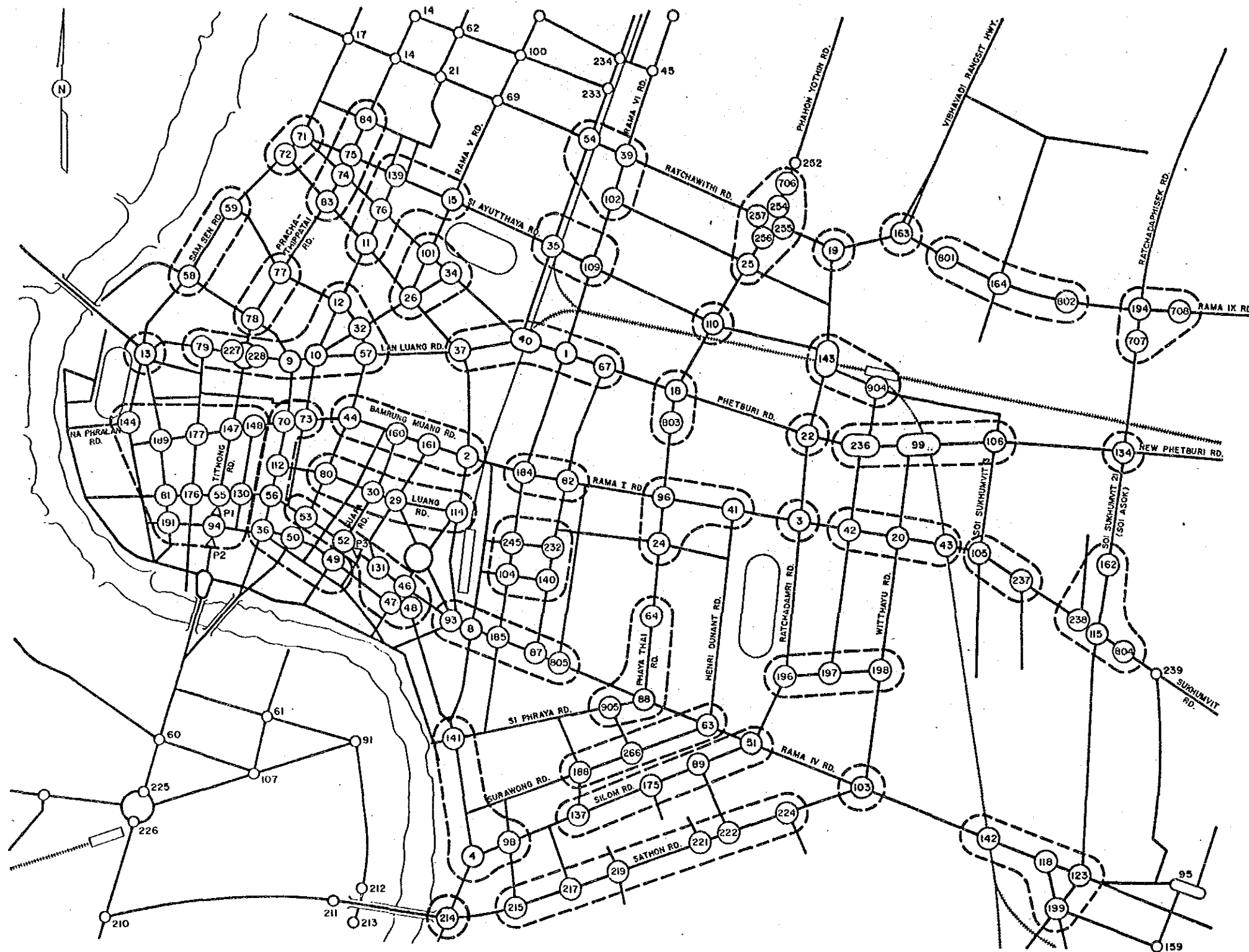

ABBREVIATION	NAME IN FULL
CPU	CENTRAL PROCESSING UNIT
FDD	FLOPPY DISK DRIVE
HD(S)	HARDISK UNIT FOR STORING PROGRAMS
HD(D)	HARDISK UNIT FOR STORING WORK DATA
CRT/KB	CRT DISPLAY / KEYBOARD
CPR	CONSOLE PRINTER
SCK	SYSTEM CLOCK
SWU	SWITCHING UNIT
LP	LINE PRINTER
MT	MAGNETIC TAPE UNIT
TCMW	TRAFFIC CONDITION MONITORING WALLMAP
EMW	EQUIPENT MONITORING WALLMAP
ID 1-3	INDICATION DRIVER
SIP	SYSTEM INDICATION PANEL
MRQ	LOCAL MANUAL REQUEST PANEL
WS	WORKSTATION
PR(L)	LASER PRINTER
SW/B	PRINTER SWITCHING BUFFER
PIB	PARALLEL INTERFACE BUS
FEP	FRONTEND PROCESSOR
CCU	CENTRAL COMMUNICATION UNIT INCLUDING PROCESSOR
MODEM	MODULATOR / DEMODULATOR
MDF	MAIN DISTRIBUTION FRAME
TOT	LEASED LINE FROM THE TELEPHONE ORGANIZATION OF THAILAND
MEA	POWER SUPPLY FROM THE METROPOLITAN ELECTIC AUTHORITY
M	WATT - HOUR METER
LC	LOCAL CONTROLLER
TT	TERMINAL TELEMTRY
SC	SIGNAL CONTROLLER
DC	DETECTOR CONTROLLER
PP	PRE - PROCESSOR FOR DETECTOR
DET	DETECTOR CABINET
USD	ULTRASONIC DETECTOR
LOOP	LOOP INDUCTIVE DETECTOR
SPR	SERIAL PRINTER
CVCF	CONSTANT VOLTAGE / CONSTANT FREQUENCY SUPPLY
EG	ENGINE GENERATOR
WT	WIRELESS TALKIE
TEL	TELEPHONE SET
FAX	FACSIMILE

TRAFFIC SIGNAL SYSTEM CONFIGURATION DIAGRAM

				BANGKOK AREA TRAFFIC CONTROL SYSTEM PROJECT : STAGE I			
Submitted By :		Jiro Kodera JICA Study Team Leader		Approved By :		Boonyawat Tipus BMA Study Team Leader	
Designed By :		Yasuo Hoshizumi JICA Study Member		Checked By :		TED.BMA	
Code	Revision	Date	Initial	JICA Japan International Cooperation Agency	BMA Bangkok Metropolitan Administration	Scale	Drawing No 1202
Associated Plan No. :				Date	SEPTEMBER '90	Total	2 / 43



LEGEND

-  TRAFFIC SIGNAL UNDER STAGE I ATC SYSTEM
-  INTERSECTION NO.
-  PEDESTRIAN CROSSING SIGNAL
-  TRAFFIC SIGNAL OUTSIDE OF STAGE I AREA
-  KEY INTERSECTION

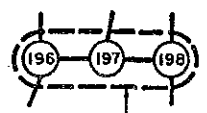

SIGNAL CONTROL SUB-AREA

TRAFFIC SIGNAL LOCATIONS

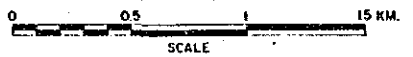

SCALE

				BANGKOK AREA TRAFFIC CONTROL SYSTEM PROJECT: STAGE I			
				SUGGESTED SUB-AREAS FOR SIGNAL SYSTEM		Submitted By :	Approved By :
						Jiro Kodera JICA Study Team Leader	Wanayut Titus BMA Study Team Leader
						Designed By :	Checked By :
						Yasuo Mabeck JICA Study Member	YES, BMA
Code	Revision	Date	Initial	JICA Japan International Cooperation Agency	BMA Bangkok Metropolitan Administration	Scale 1/15,000	Drawing NR 1203
Associated Plan No. :						Date SEPTEMBER '60	Total 3/43

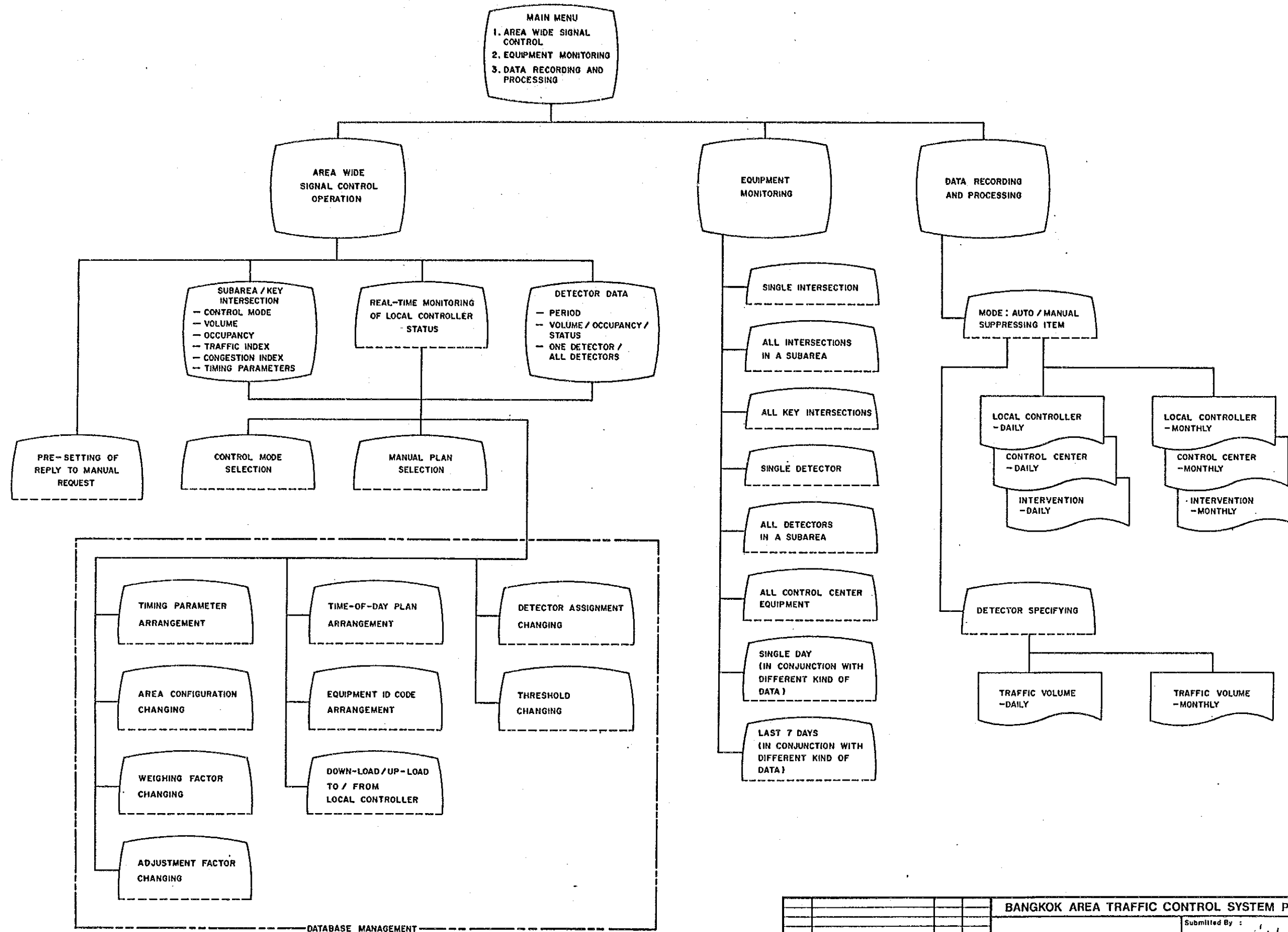

				BANGKOK AREA TRAFFIC CONTROL SYSTEM PROJECT : STAGE I			
				Submitted By :		Approved By :	
				JICA Study Team Leader		BMA Study Team Leader	
				Designed By :		Checked By :	
				JICA Study Member		YEO, BMA	
Code	Revision	Date	Initial	JICA	BMA	Scale	Drawing No
Associated Plan No. :				Japan International Cooperation Agency	Bangkok Metropolitan Administration		1204
				Date	SEPTEMBER '90	Total	4 / 43

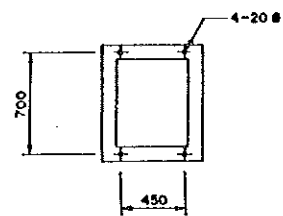
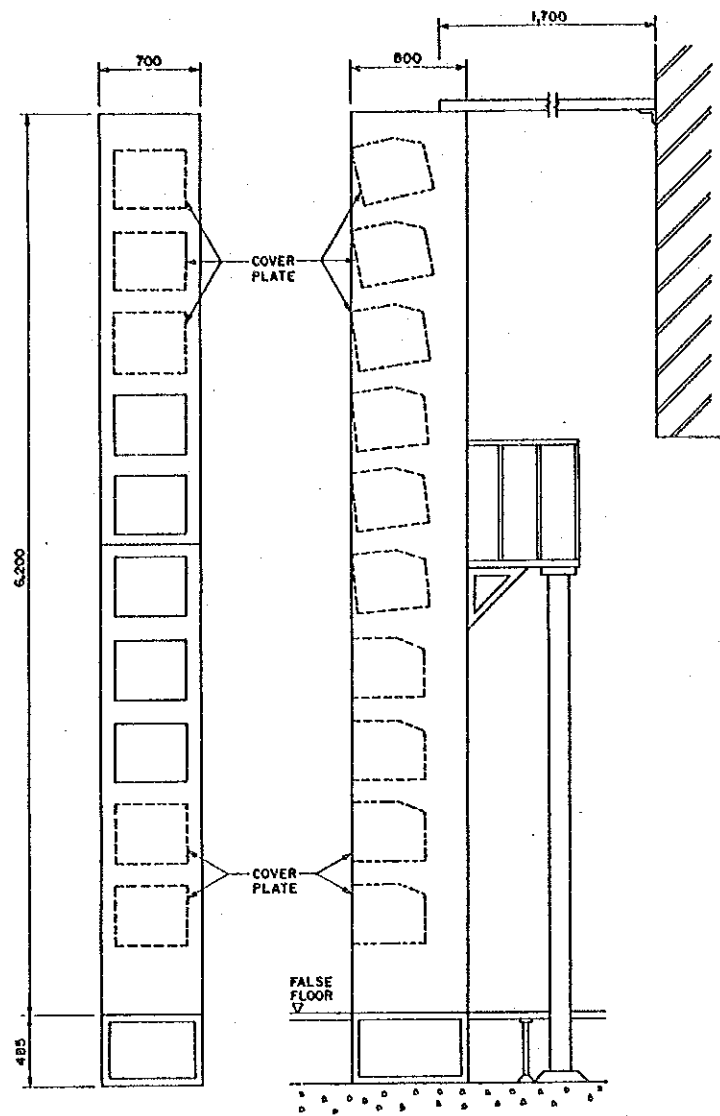

CCTV MONITOR PANEL

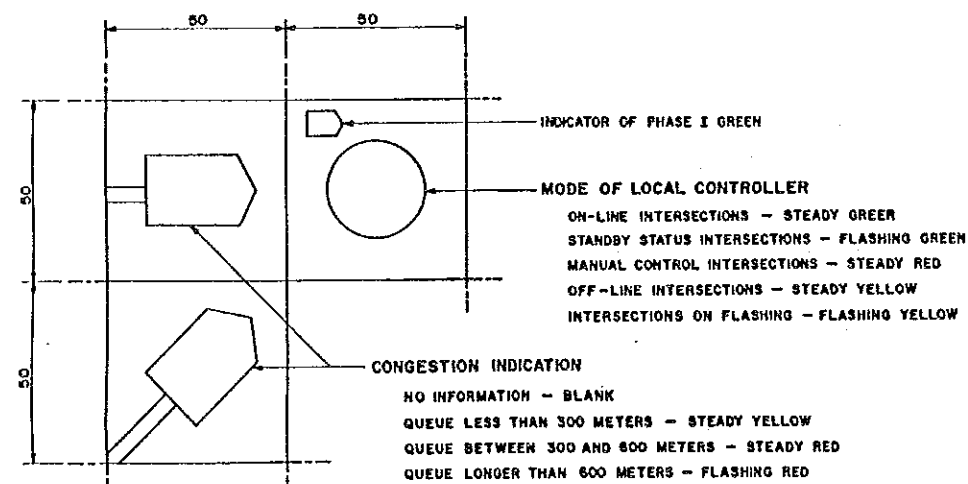

MOSAIC SYMBOL

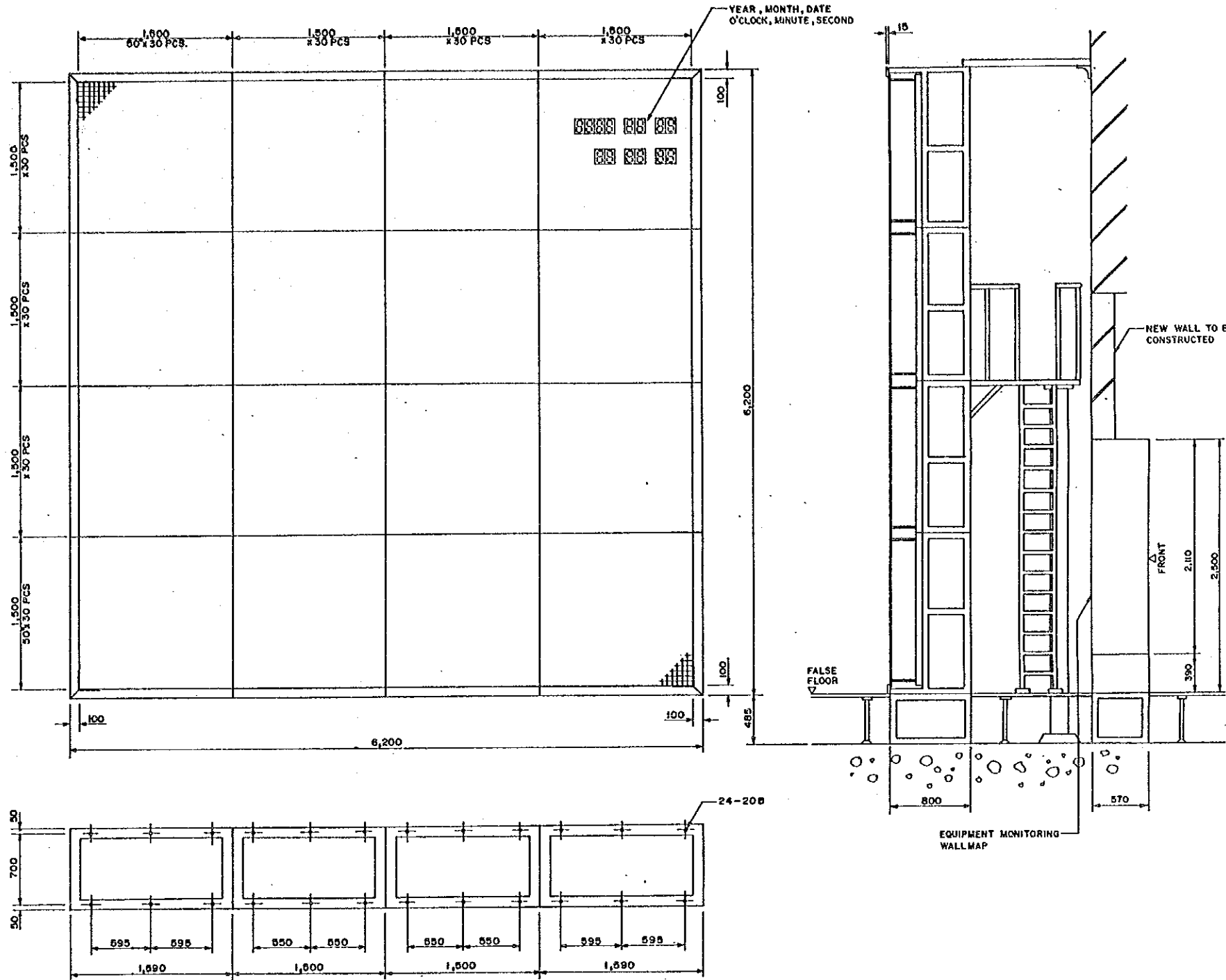



TRAFFIC CONDITION MONITORING WALLMAP





BANGKOK AREA TRAFFIC CONTROL SYSTEM PROJECT : STAGE I			
TRAFFIC CONDITION MONITORING WALLMAP		Submitted By : Jure Kodera JICA Study Team Leader	Approved By : Boonyawat Tiptus BMA Study Team Leader
		Designed By : Yasuo Kobayashi JICA Study Member	Checked By : TED, BMA
Code	Revision	Date	Initial
Associated Plan No. :		JICA Japan International Cooperation Agency	BMA Bangkok Metropolitan Administration
		Scale	Drawing N2 1205
		Date SEPTEMBER '90	Total 5 / 43

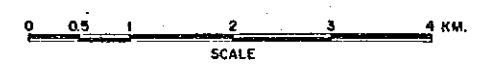

LEGEND

-  INDICATION TO BE CONSIDERED WITHIN WALLMAPS INCLUDING EXPANSION
-  APPROACH TO BE INDICATED
-  AREA OF STAGE I







BANGKOK AREA TRAFFIC CONTROL SYSTEM PROJECT : STAGE I			
<p style="text-align: center;">AREA COVERED WITHIN WALLMAPS</p>		Submitted By : 	Approved By : 
		JICA Study Team Leader	BMA Study Team Leader
<p>Code Revision Date Initial</p>		Designed By : 	Checked By : 
		JICA Study Member	TED, BMA
<p>Associated Plan No. :</p>		<p>JICA BMA</p> <p>Japan International Bangkok Metropolitan</p> <p>Cooperation Agency Administration</p>	<p>Scale Drawing No</p> <p>Date SEPTEMBER '90 Total 6 / 43</p>

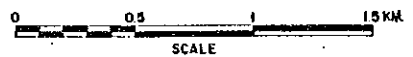
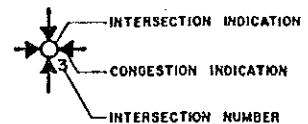

LEGEND

ILLUMINATED INDICATION TO BE FURNISHED IN STAGE I



				BANGKOK AREA TRAFFIC CONTROL SYSTEM PROJECT: STAGE I			
				Submitted By : 		Approved By : 	
				JICA Study Team Leader		BMA Study Team Leader	
				Designed By : 		Checked By : 	
				JICA Study Member		TED, BMA	
Code	Revision	Date	Initial	JICA	BMA	Scale	1 / 15,000
Associated Plan No. 1				Japan International Cooperation Agency	Bangkok Metropolitan Administration	Drawing No	1206-2
				Date	SEPTEMBER '60	Total	7 / 43

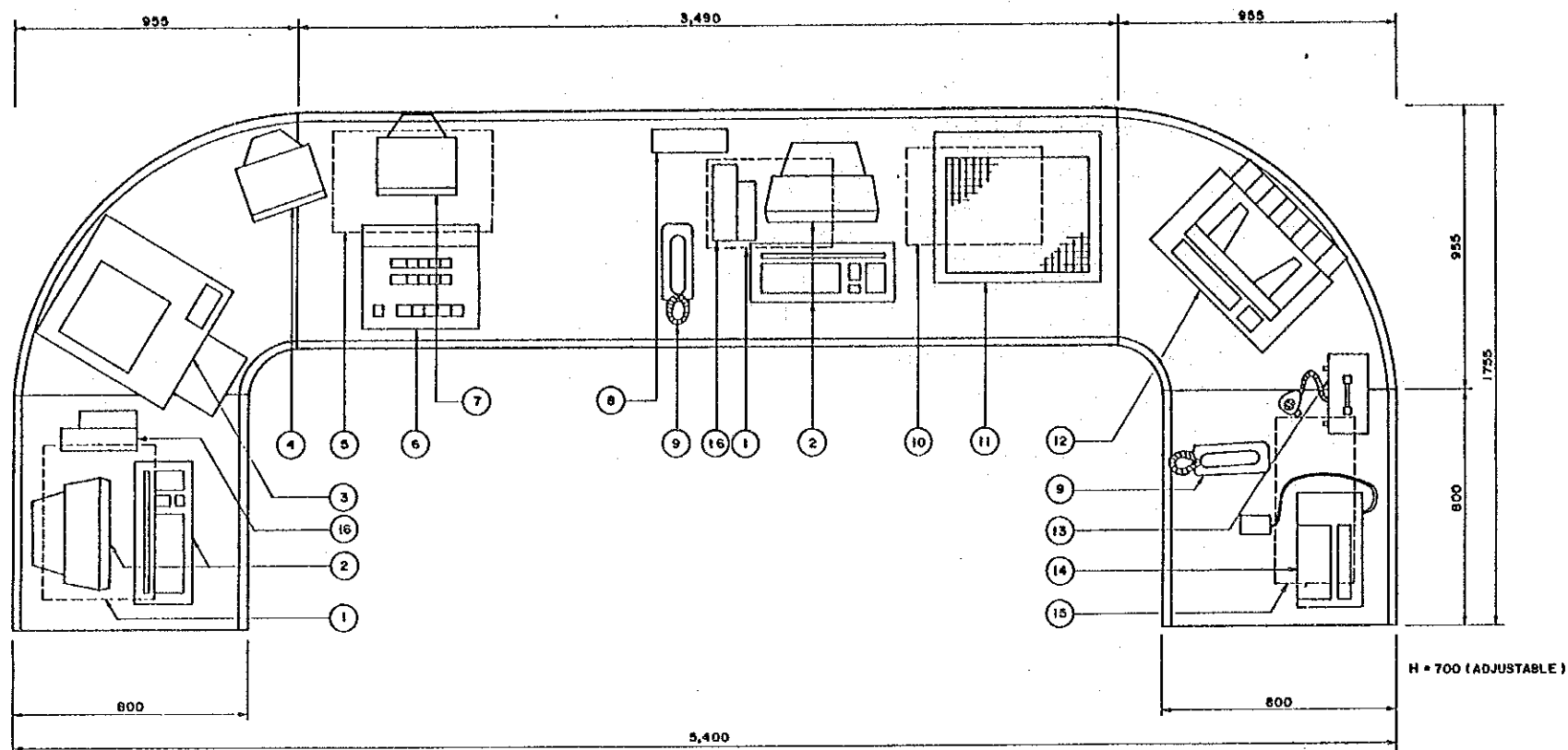

NO.	EQUIPMENT
①	WORKSTATION UNIT
②	WORKSTATION CRT / KEY BOARD
③	LASER PRINTER
④	TV MONITOR FOR VTR
⑤	VTR
⑥	CCTV OPERATION CONSOLE
⑦	TV MONITOR FOR CAMERA CONTROL
⑧	SYSTEM INDICATION PANEL
⑨	TELEPHONE SET
⑩	INDICATION DRIVER FOR ⑧, ⑪
⑪	LOCAL MANUAL PANEL
⑫	FACSIMILE
⑬	WIRELESS TALKIE (TRAFFIC POLICE)
⑭	WIRELESS TALKIE (BMA)
⑮	POWER AMPLIFIER FOR ⑭
⑯	FLOPPY DISK UNIT (5" AND 3.5")

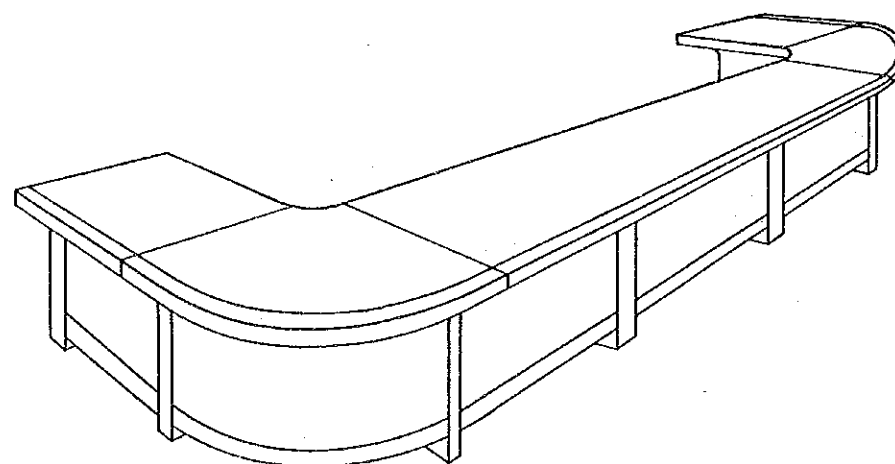

CONTROL DESK

BANGKOK AREA TRAFFIC CONTROL SYSTEM PROJECT : STAGE I			
Code		Submitted By : <i>Jure Kodera</i>	
		Approved By : <i>Boonyawat Tiptus</i>	
Revision		JICA Study Team Leader	
		BMA Study Team Leader	
Date		Designed By : <i>Yasuo Mabeenima</i>	
		Checked By : <i>TEO, BMA</i>	
Initial		JICA Study Member	
		TEO, BMA	
Associated Plan No. :		JICA Japan International Cooperation Agency	BMA Bangkok Metropolitan Administration
		Scale	Drawing No. 1208
		Date SEPTEMBER '90	Total 9 / 43

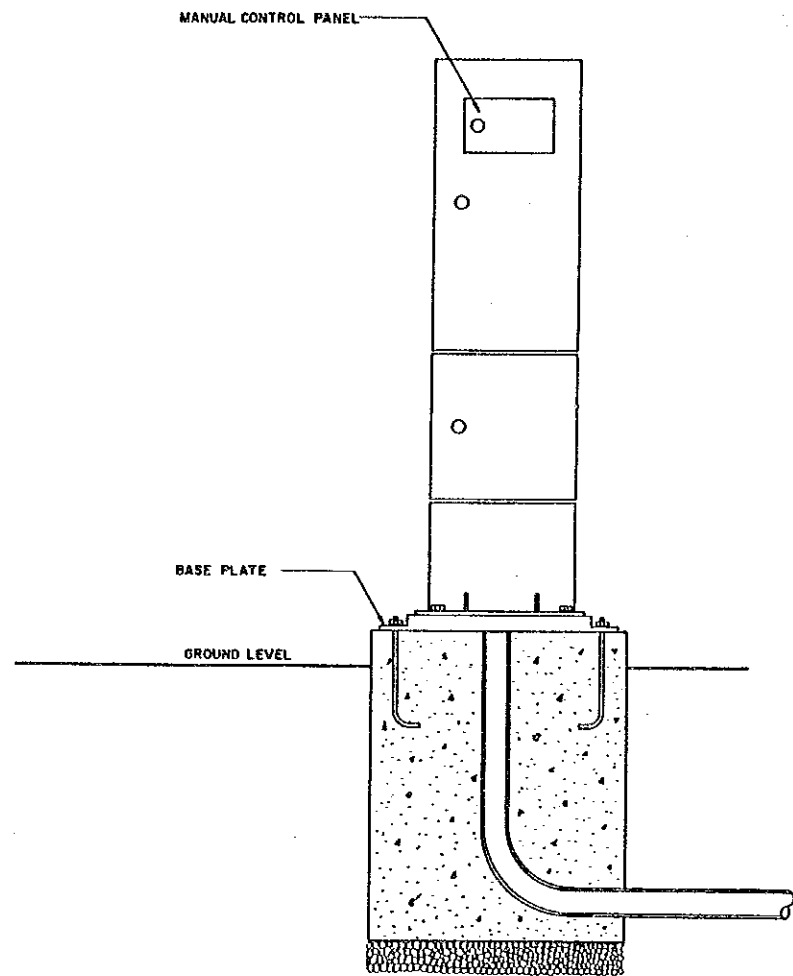

FRONT VIEW

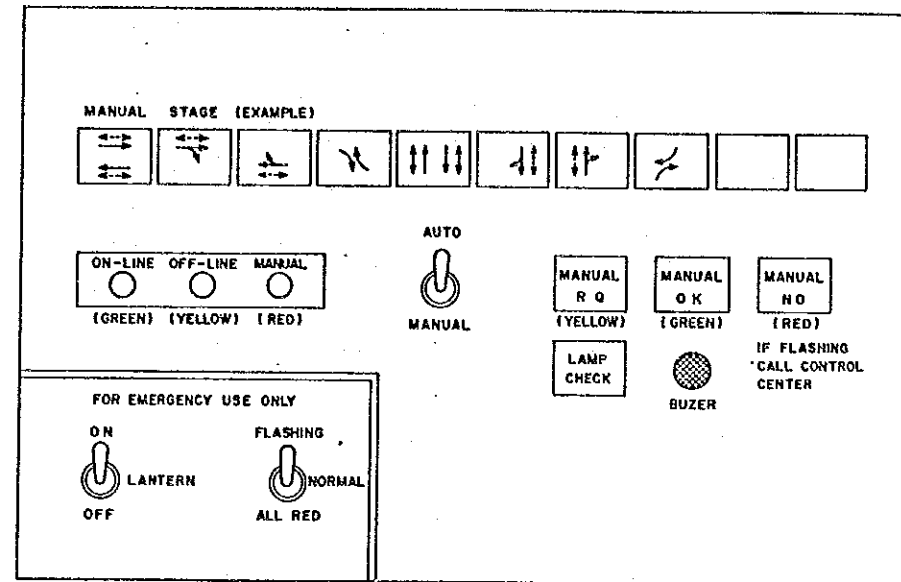

(RED) - INDICATE LAMP COLOR NOT PANEL LEGEND

MANUAL CONTROL PANEL

				BANGKOK AREA TRAFFIC CONTROL SYSTEM PROJECT : STAGE I			
				IMAGE OF MANUAL CONTROL PANEL		Submitted By :	Approved By :
						Jura Kodera JICA Study Team Leader	Boonsawat Tiptus BMA Study Team Leader
						Designed By :	Checked By :
						Yasuo Nabeshima JICA Study Member	TED, BMA
Code	Revision	Date	Initial	JICA	BMA	Scale	Drawing NR 1209
Associated Plan No. :				Japan International Cooperation Agency	Bangkok Metropolitan Administration	Date	Total 10 / 43
						SEPTEMBER '90	

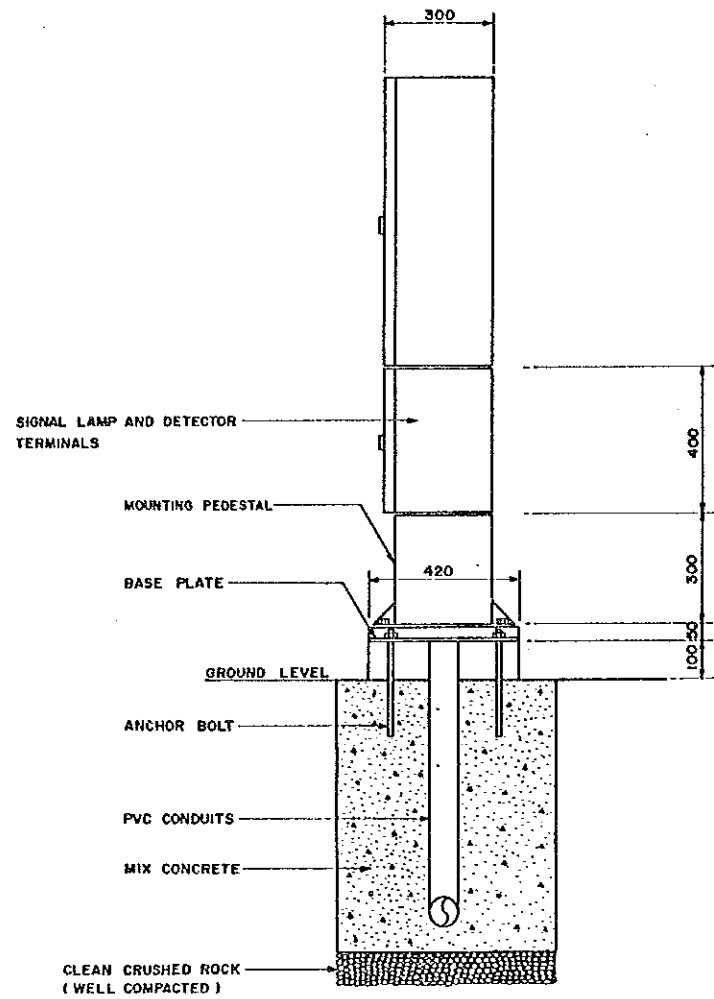

SIDE VIEW

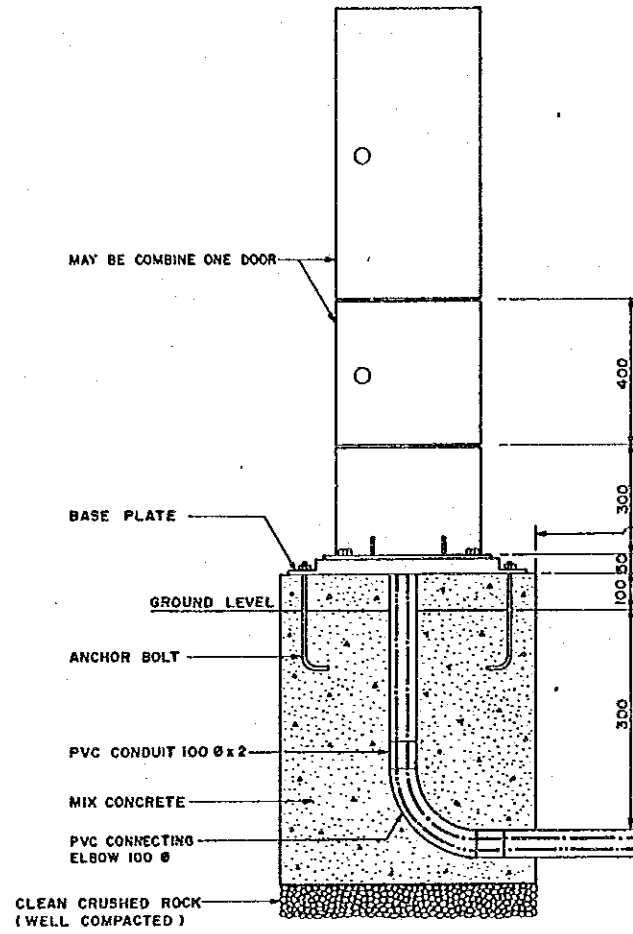

FRONT VIEW

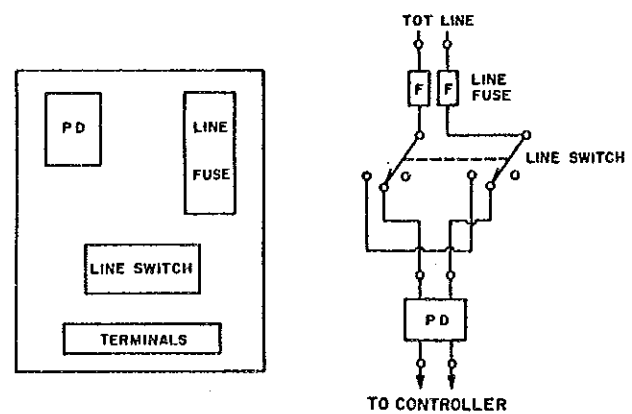
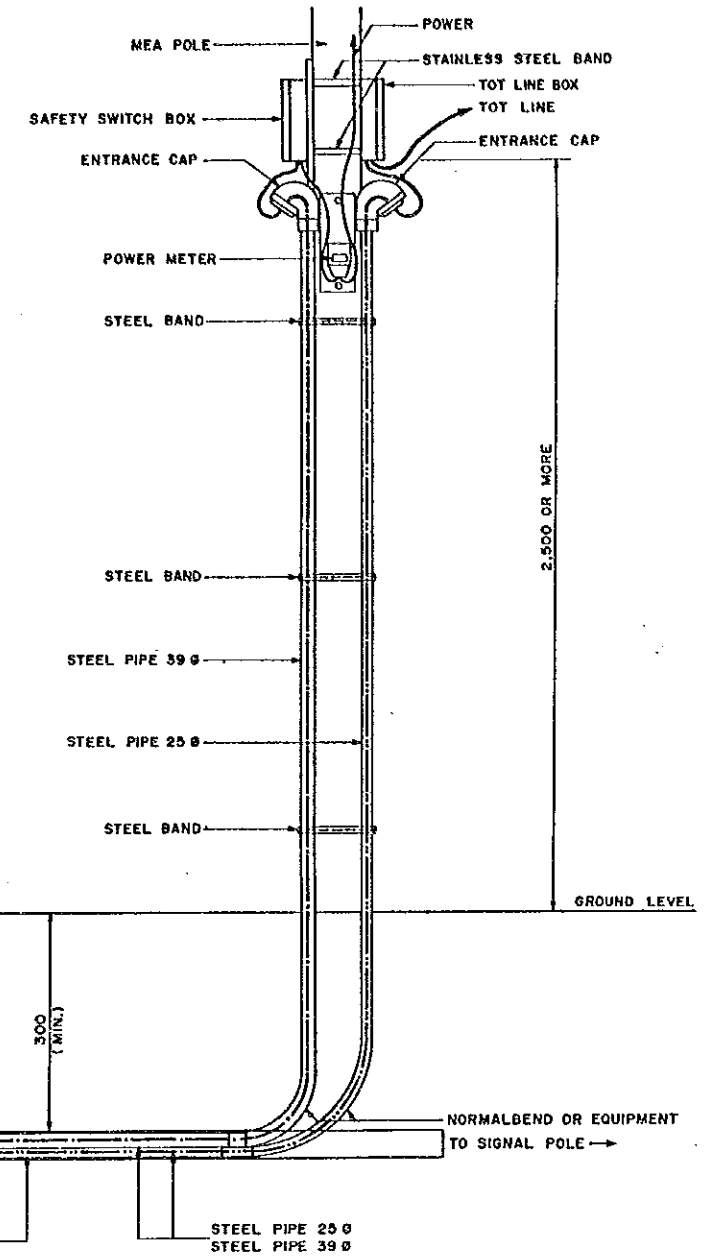

LAYOUT OF TOT LINE SWITCH AND FUSE PD BOARD

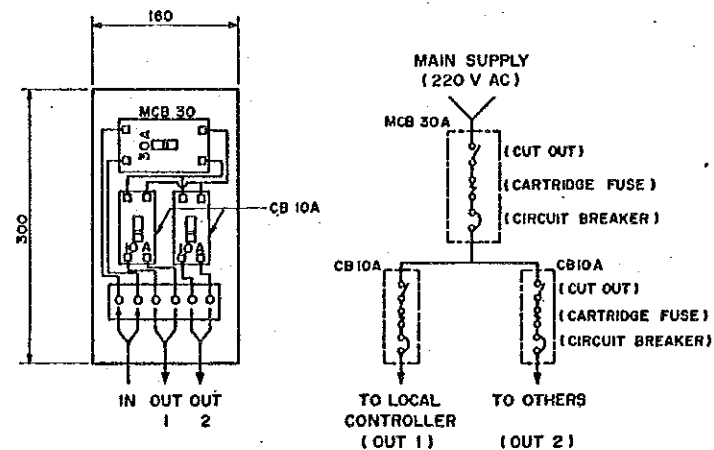

LAYOUT OF POWER SUPPLY SAFETY SWITCH BOX

BANGKOK AREA TRAFFIC CONTROL SYSTEM PROJECT : STAGE I			
MOUNTING FACILITIES OF LOCAL CONTROLLER		Submitted By :	Approved By :
		Juro Kodera JICA Study Team Leader	Boonyawat Tiplus BMA Study Team Leader
Associated Plan No. :		Designed By :	Checked By :
		Yasuo Nabeshima JICA Study Member	TED, BMA
JICA Japan International Cooperation Agency	BMA Bangkok Metropolitan Administration	Scale	Drawing No 1210
		Date SEPTEMBER '90	Total 11 / 43

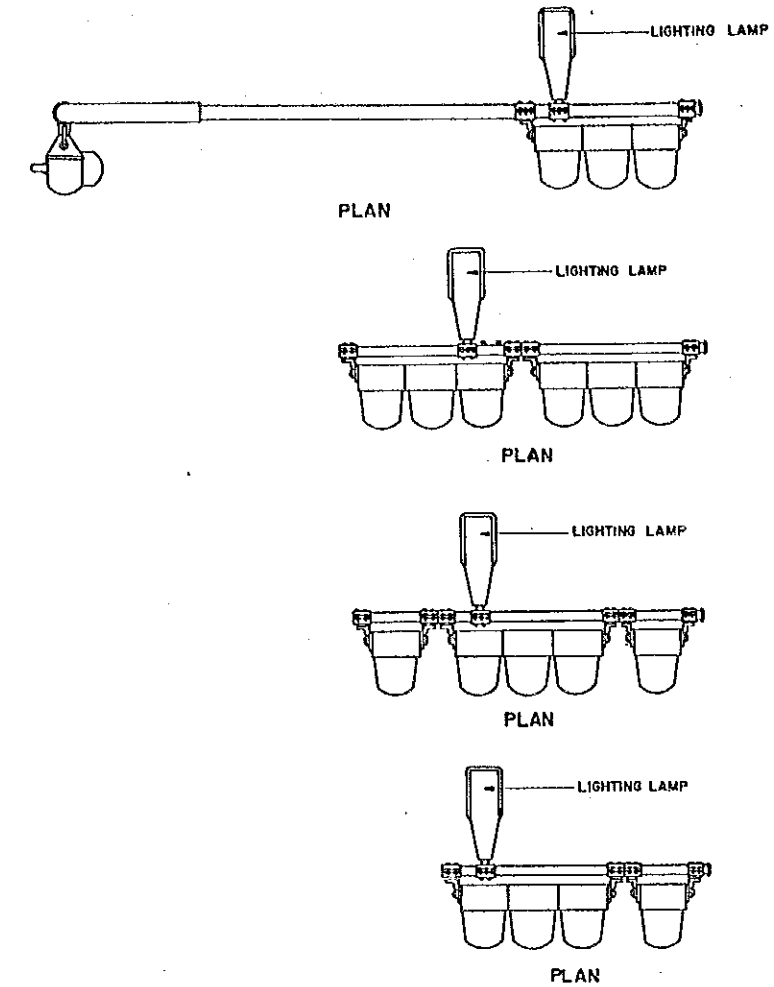
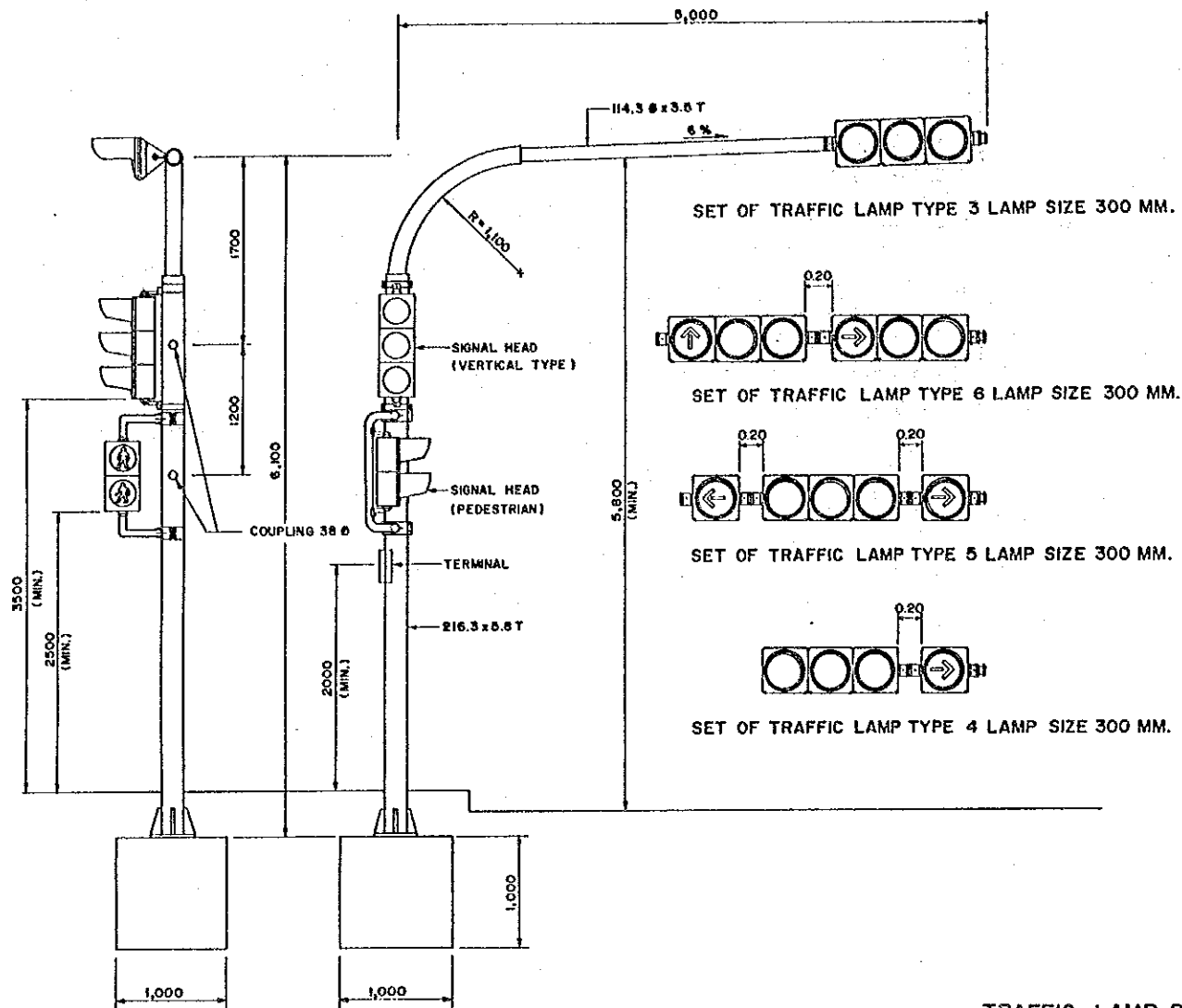

TRAFFIC LAMP SET TYPE HIGH POLE AND ARM WITH LIGHTING LAMP

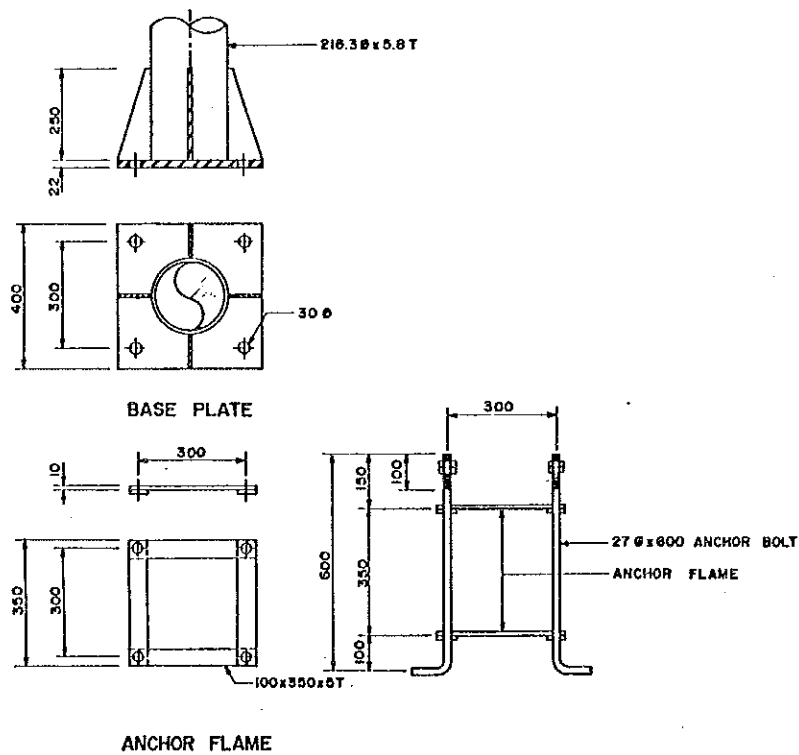

				BANGKOK AREA TRAFFIC CONTROL SYSTEM PROJECT : STAGE I			
				Submitted By :		Approved By :	
				Juro Kodera JICA Study Team Leader		Keonwan Titlus BMA Study Team Leader	
				Designed By :		Checked By :	
				Yasuo Mochizuki JICA Study Member		TED, BMA	
Code	Revision	Date	Initial	JICA	BMA	Scale	Drawing No
Associated Plan No. :				Japan International Cooperation Agency	Bangkok Metropolitan Administration	SEPTMBER' 80	1211
				Date		Total	
				SEPTEMBER' 80		12 / 43	

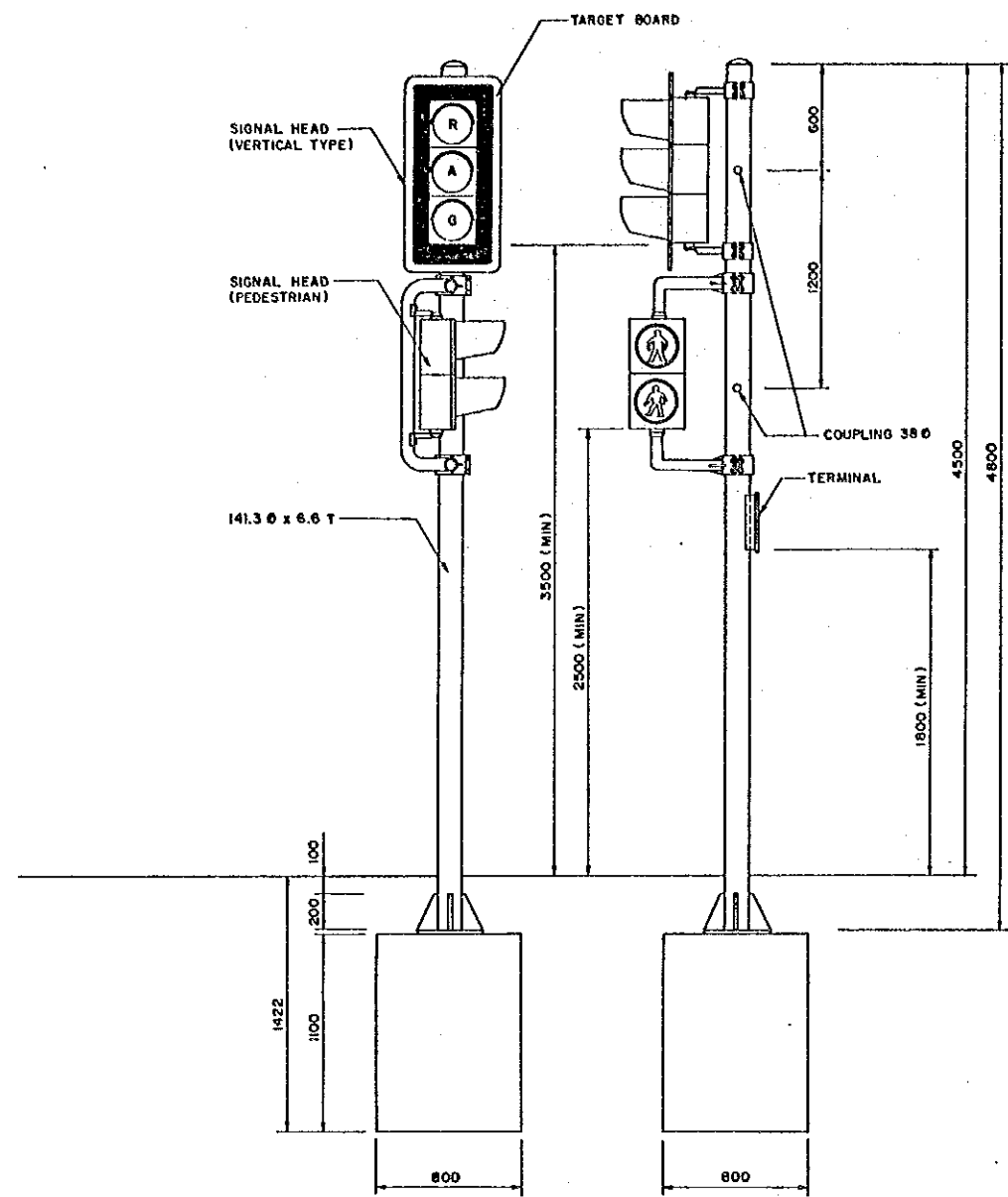

TRAFFIC LAMP SET TYPE LOW POLE

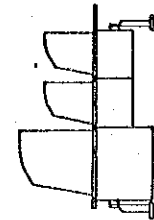
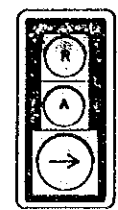

SET OF TRAFFIC LAMP TYPE 3 LAMP

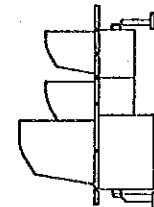
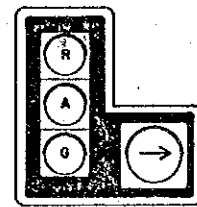

SET OF TRAFFIC LAMP TYPE 4 LAMP

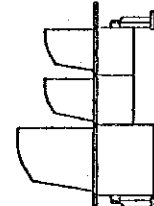
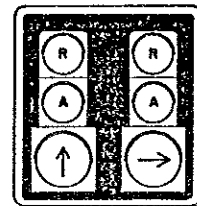

SET OF TRAFFIC LAMP TYPE 6 LAMP

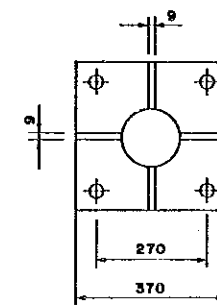
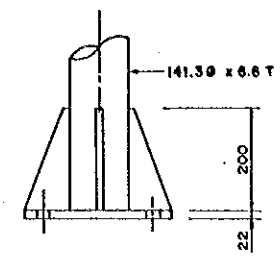

BASE PLATE

				BANGKOK AREA TRAFFIC CONTROL SYSTEM PROJECT : STAGE I			
				TRAFFIC SIGNAL POLES AND FOOTING TYPE B		Submitted By :	Approved By :
						Jure Kodera JICA Study Team Leader	Boonyawat Tipus BMA Study Team Leader
						Designed By :	Checked By :
						Yeeue Nabeshima JICA Study Member	TED, BMA
Code	Revision	Date	Initial	JICA	BMA	Scale	Drawing NR
Associated Plan No. :				Japan International Cooperation Agency	Bangkok Metropolitan Administration	Date	1212
						SEPTEMBER '90	Total
							13 / 43

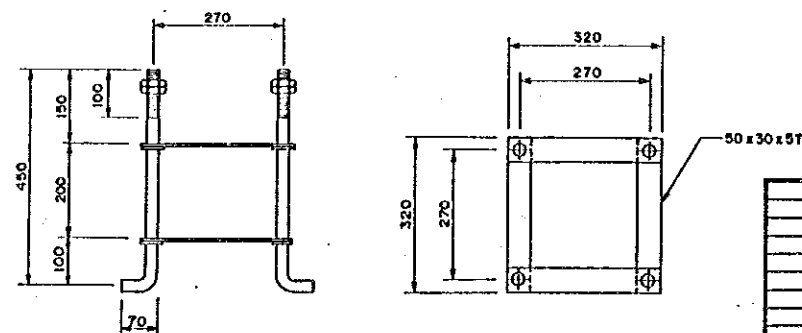
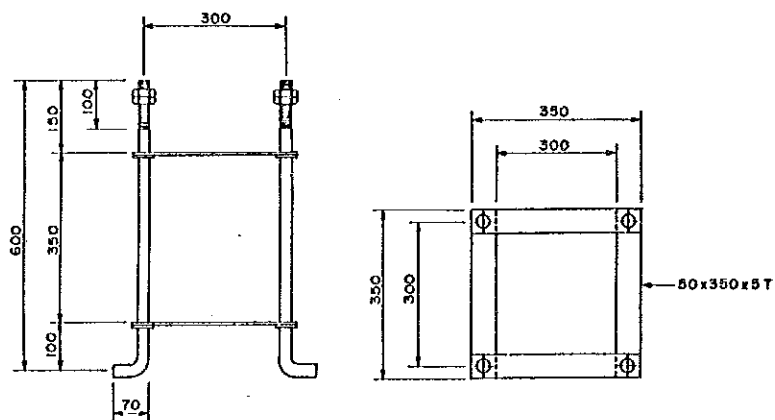
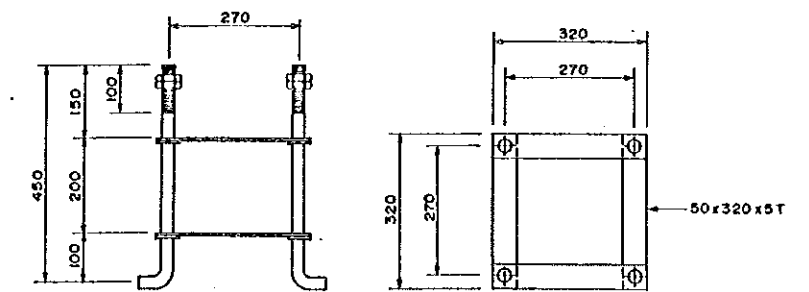
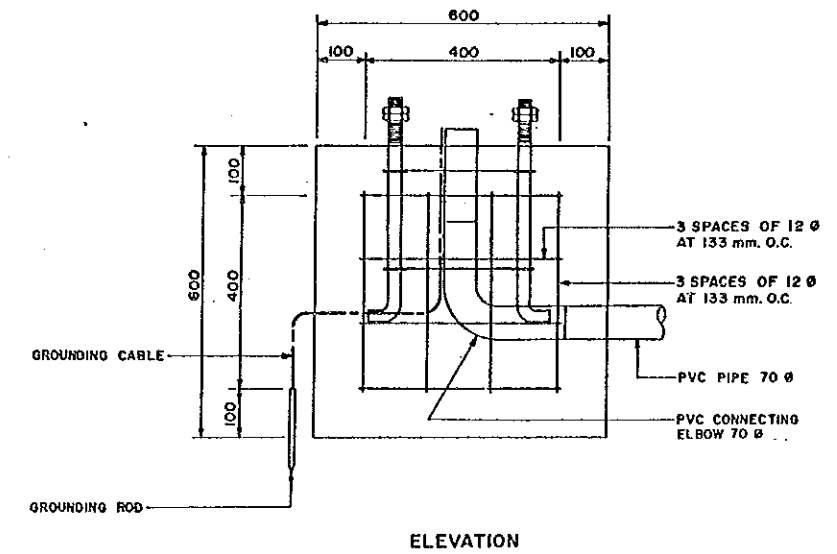
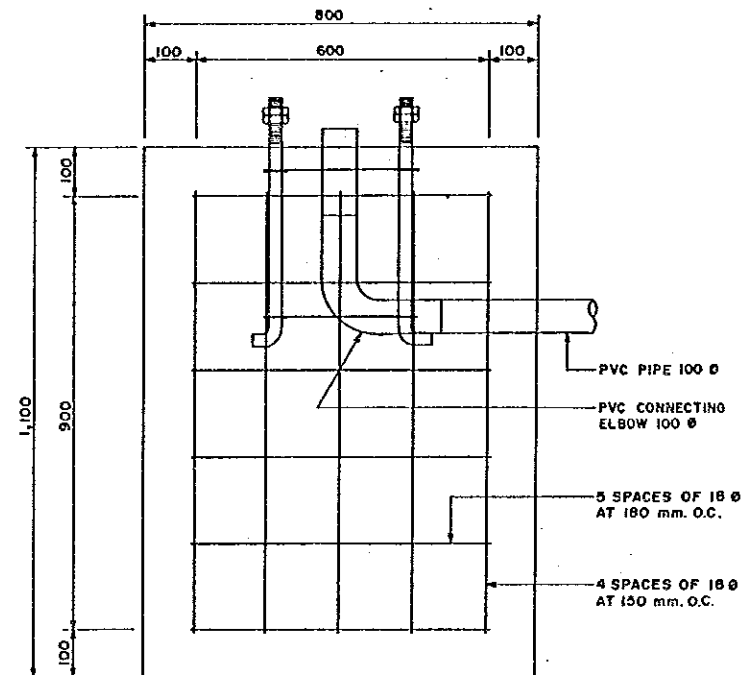
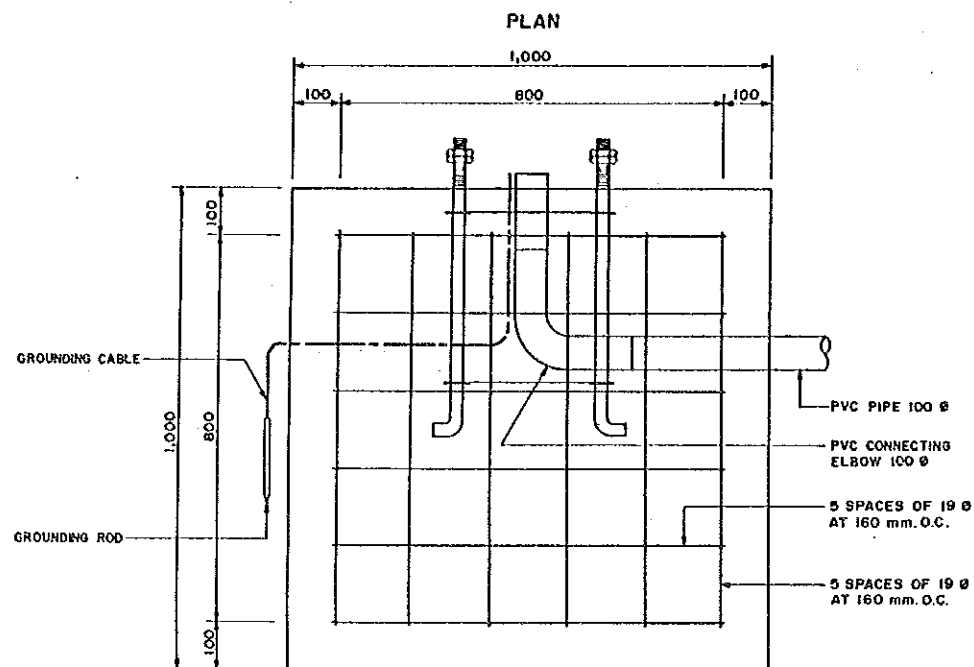
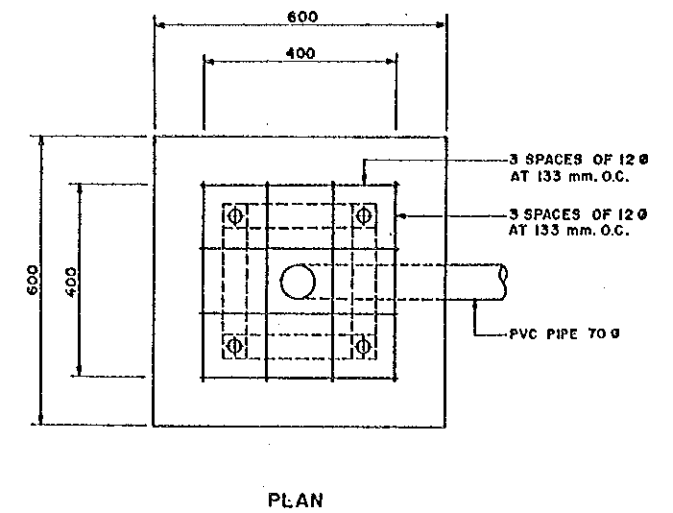
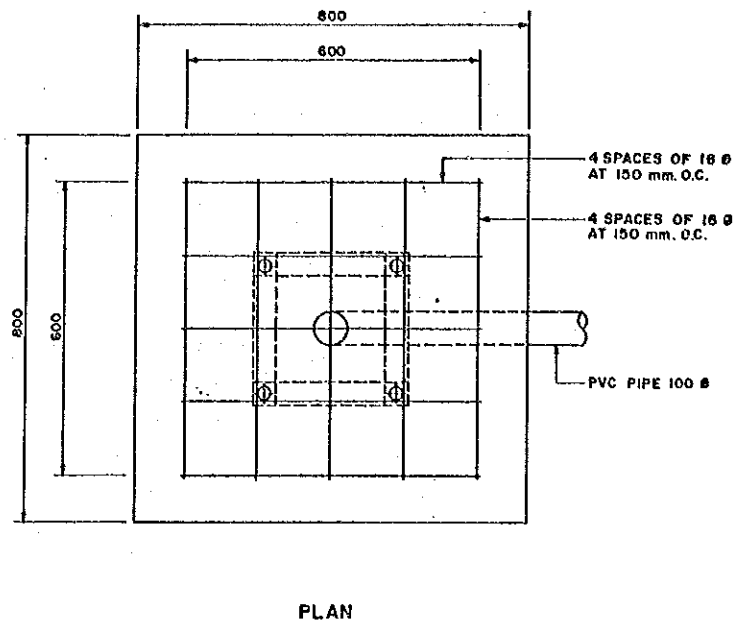
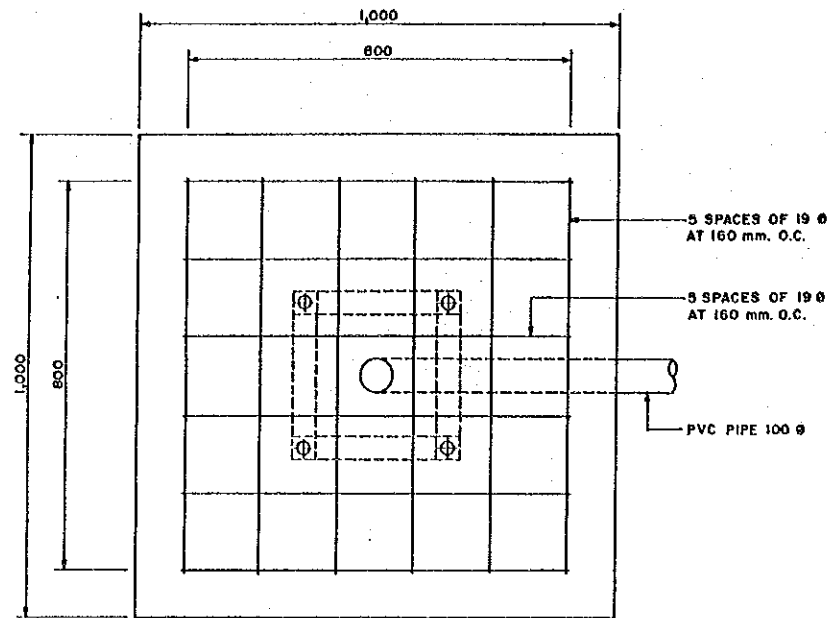

FRAME PLATE AND ANCHOR BOLT
ULTRASONIC DETECTOR POLE
& SIGNAL MAST ARM (TYPE A)

FRAME PLATE AND ANCHOR BOLT
SIGNAL SHORT POLE
(TYPE B)

FRAME PLATE AND ANCHOR BOLT
LOOP COIL DETAIL
SHORT POLE

BANGKOK AREA TRAFFIC CONTROL SYSTEM PROJECT : STAGE I			
SIGNAL & DETECTOR FOUNDATION		Submitted By : Juro Kodera JICA Study Team Leader	Approved By : Boonyarat Tiptus BMA Study Team Leader
		Designed By : Yasuo Mubashima JICA Study Member	Checked By : TEO, BMA
Code	Revision	Date	Initial
Associated Plan No. :		JICA Japan International Cooperation Agency	BMA Bangkok Metropolitan Administration
		Scale	Drawing NR 1215
		Date SEPTEMBER '90	Total 16 / 43



- LEGEND**
- ⊙ TRAFFIC SIGNAL (KEY-INTERSECTION) UNDER ATC STAGE I AREA
 - TRAFFIC SIGNAL UNDER ATC STAGE I AREA
 - △ P PEDESTRIAN CROSSING SIGNAL UNDER ATC STAGE I AREA
 - ▽ ULTRASONIC DETECTOR 150 M FROM STOP LINE
 - ▽ ULTRASONIC DETECTOR 300 M FROM STOP LINE
 - ▽ ULTRASONIC DETECTOR 600 M FROM STOP LINE
 - ▽ LOOP DETECTOR 150 M FROM STOP LINE
 - ▽ LOOP DETECTOR 300 M FROM STOP LINE
 - ▽ LOOP DETECTOR 600 M FROM STOP LINE
 - LOOP DETECTOR FOR ACTUATED CONTROL
 - TRAFFIC SIGNAL OUTSIDE OF ATC STAGE I AREA



				BANGKOK AREA TRAFFIC CONTROL SYSTEM PROJECT: STAGE I			
				DETECTOR LOCATION		Submitted By :	Approved By :
						Jiro Kodera JICA Study Team Leader	Boonyawat Tiptua BMA Study Team Leader
						Designed By :	Checked By :
						Yasuo Nabeshima JICA Study Member	TED, BMA
Code	Revision	Date	Initial	JICA Japan International Cooperation Agency	BMA Bangkok Metropolitan Administration	Scale 1 / 15,000	Drawing No 1216
Associated Plan No. 1						Date SEPTEMBER '90	Total 17 / 43

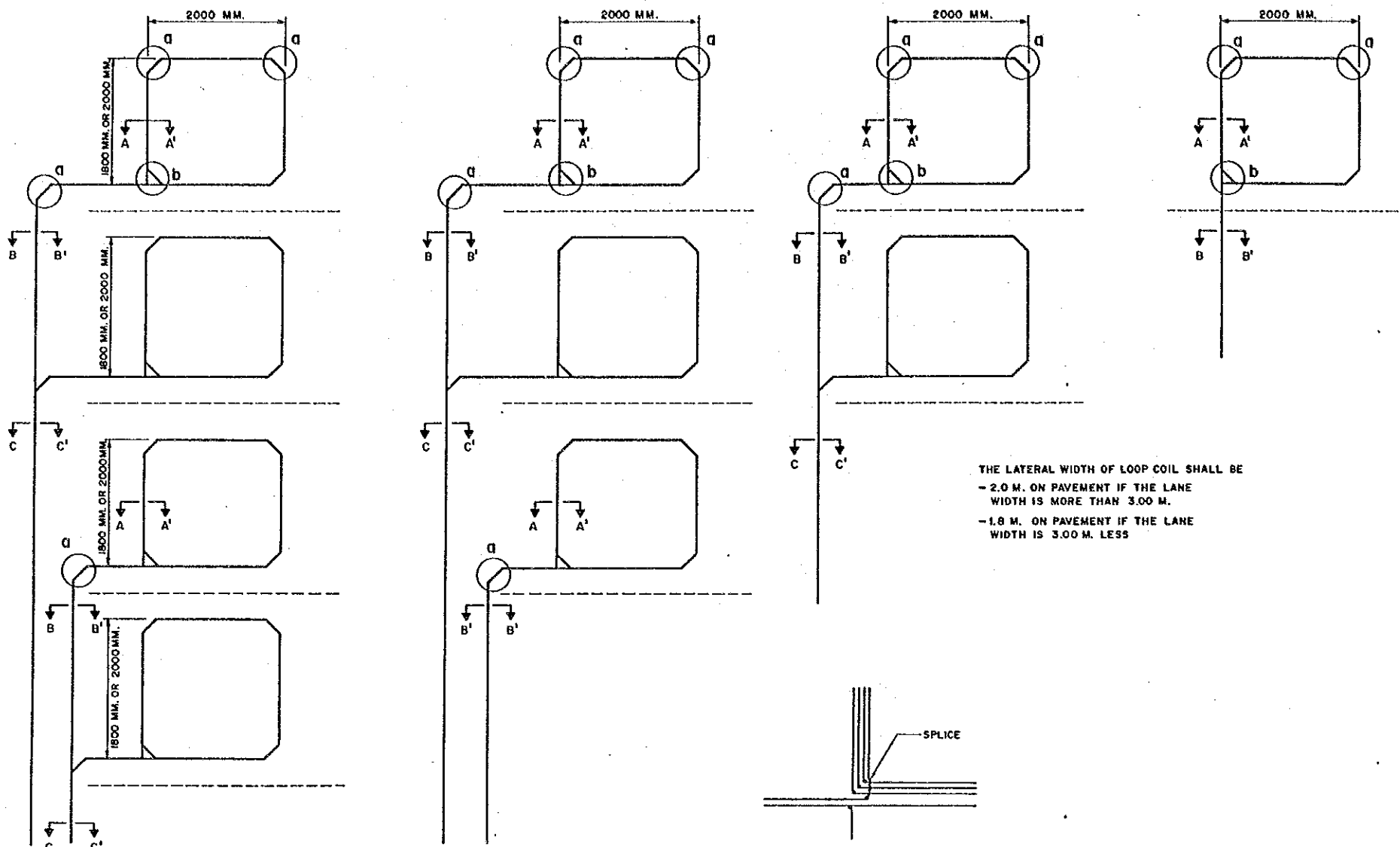

THE LATERAL WIDTH OF LOOP COIL SHALL BE
 - 2.0 M. ON PAVEMENT IF THE LANE WIDTH IS MORE THAN 3.00 M.
 - 1.8 M. ON PAVEMENT IF THE LANE WIDTH IS 3.00 M. LESS

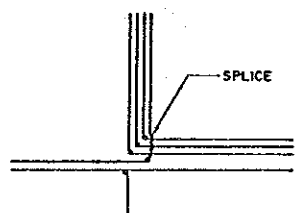

DETAIL b

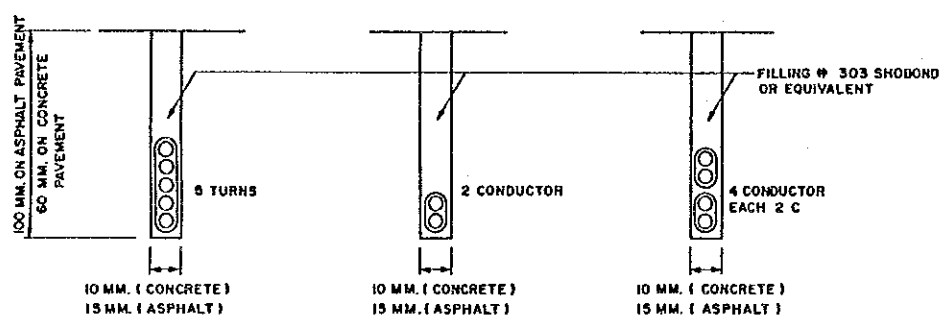
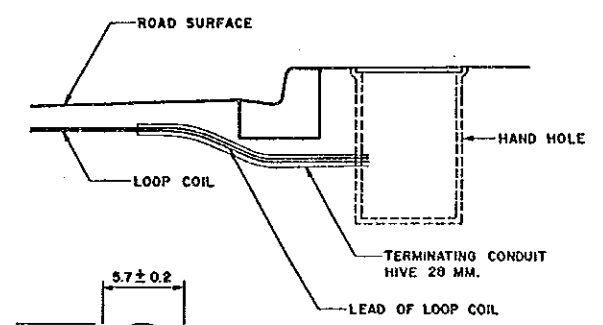
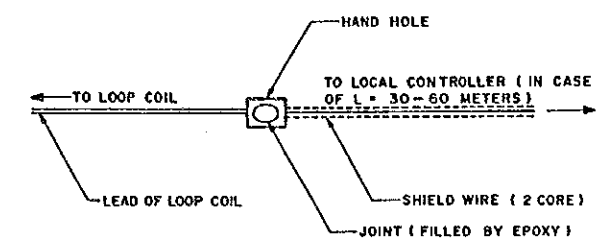
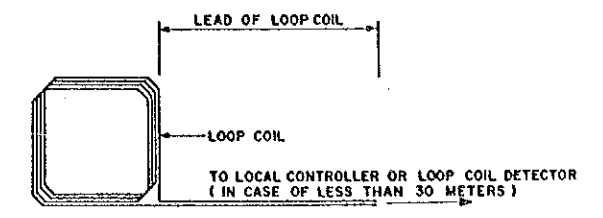

SECTION A - A' SECTION B - B' SECTION C - C'

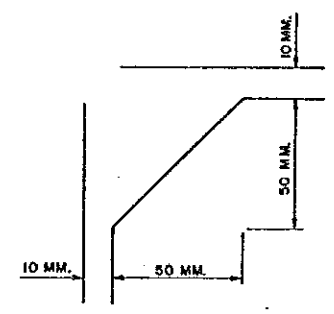

DETAIL d

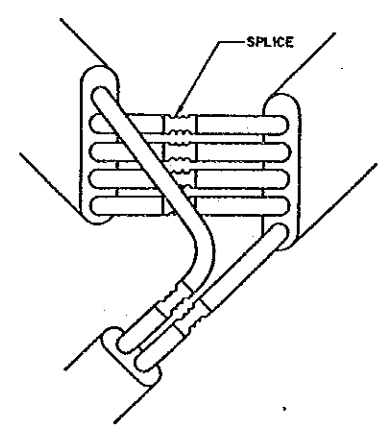
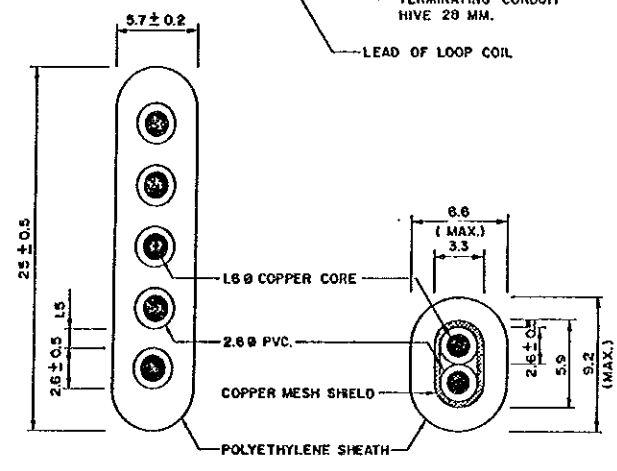
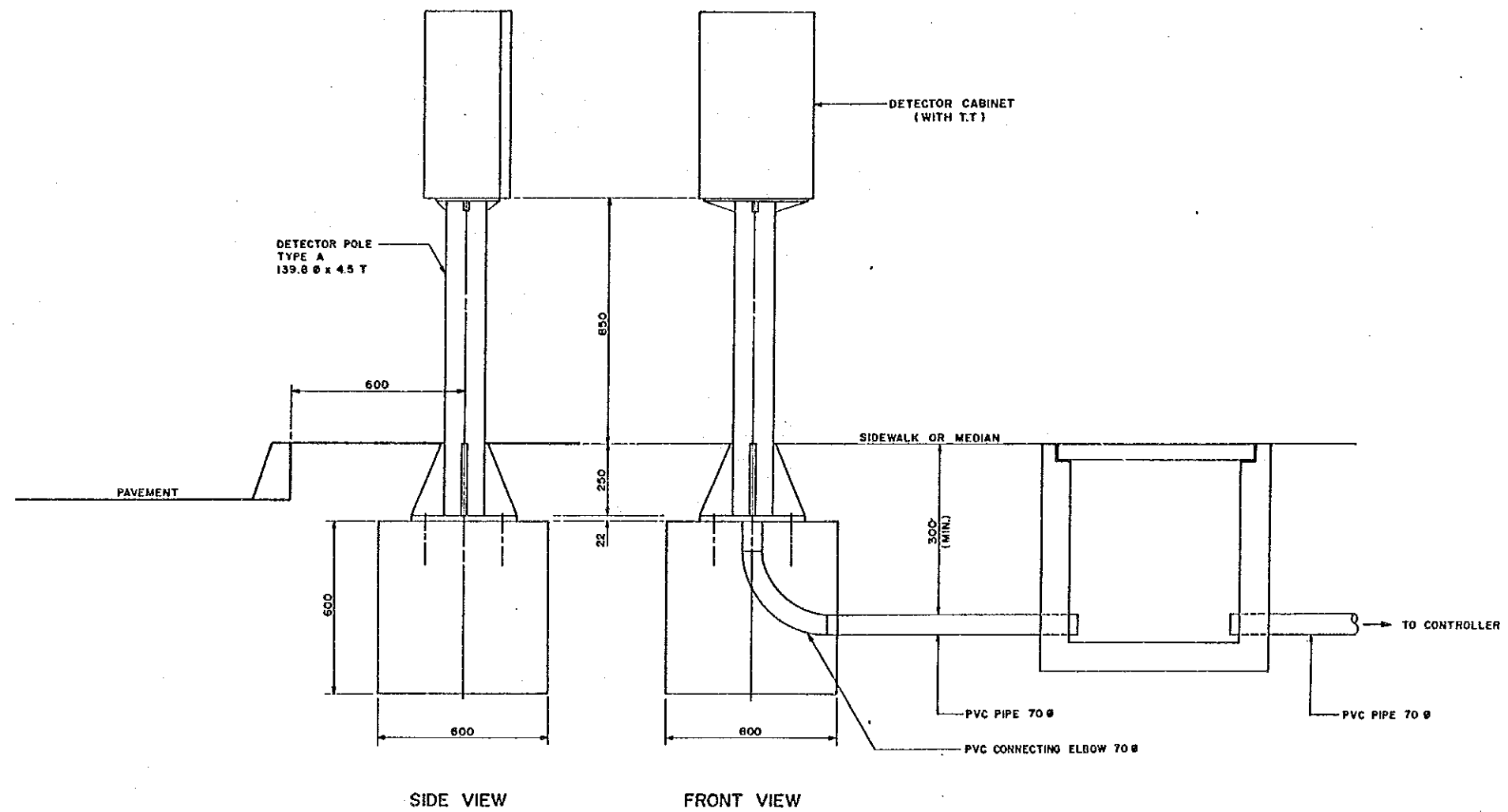

IMAGE OF POINT b



CABLE DETAIL

				BANGKOK AREA TRAFFIC CONTROL SYSTEM PROJECT : STAGE I			
				LOOP COIL DETECTOR INSTALLATION PLAN		Submitted By :	Approved By :
						Jiro Kodera JICA Study Team Leader	Banyawat Tiptan BMA Study Team Leader
						Designed By :	Checked By :
						Yasuo Hoshikawa JICA Study Member	TEO, BMA
Code	Revision	Date	Initial	JICA	BMA	Scale	Drawing NR
Associated Plan No. :				JICA Japan International Cooperation Agency	BMA Bangkok Metropolitan Administration	Date	1217
						SEPTEMBER '90	Total
							18 / 43



				BANGKOK AREA TRAFFIC CONTROL SYSTEM PROJECT : STAGE I			
				MOUNTING FACILITIES OF DETECTOR CABINET TYPE I (LOOP TYPE)		Submitted By :	Approved By :
						Jiro Kodera JICA Study Team Leader	Boonyawat Tiptua BMA Study Team Leader
						Designed By :	Checked By :
						Yasue Nabeshima JICA Study Member	TEO, BMA
Code	Revision	Date	Initial	JICA	BMA	Scale	Drawing NR 1218
Associated Plan No. :				Japan International Cooperation Agency	Bangkok Metropolitan Administration	Date SEPTEMBER '90	Total 19 / 43

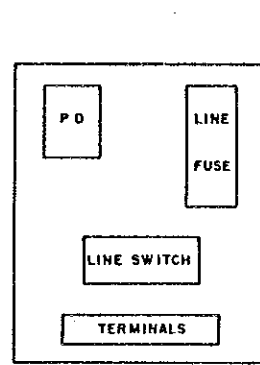
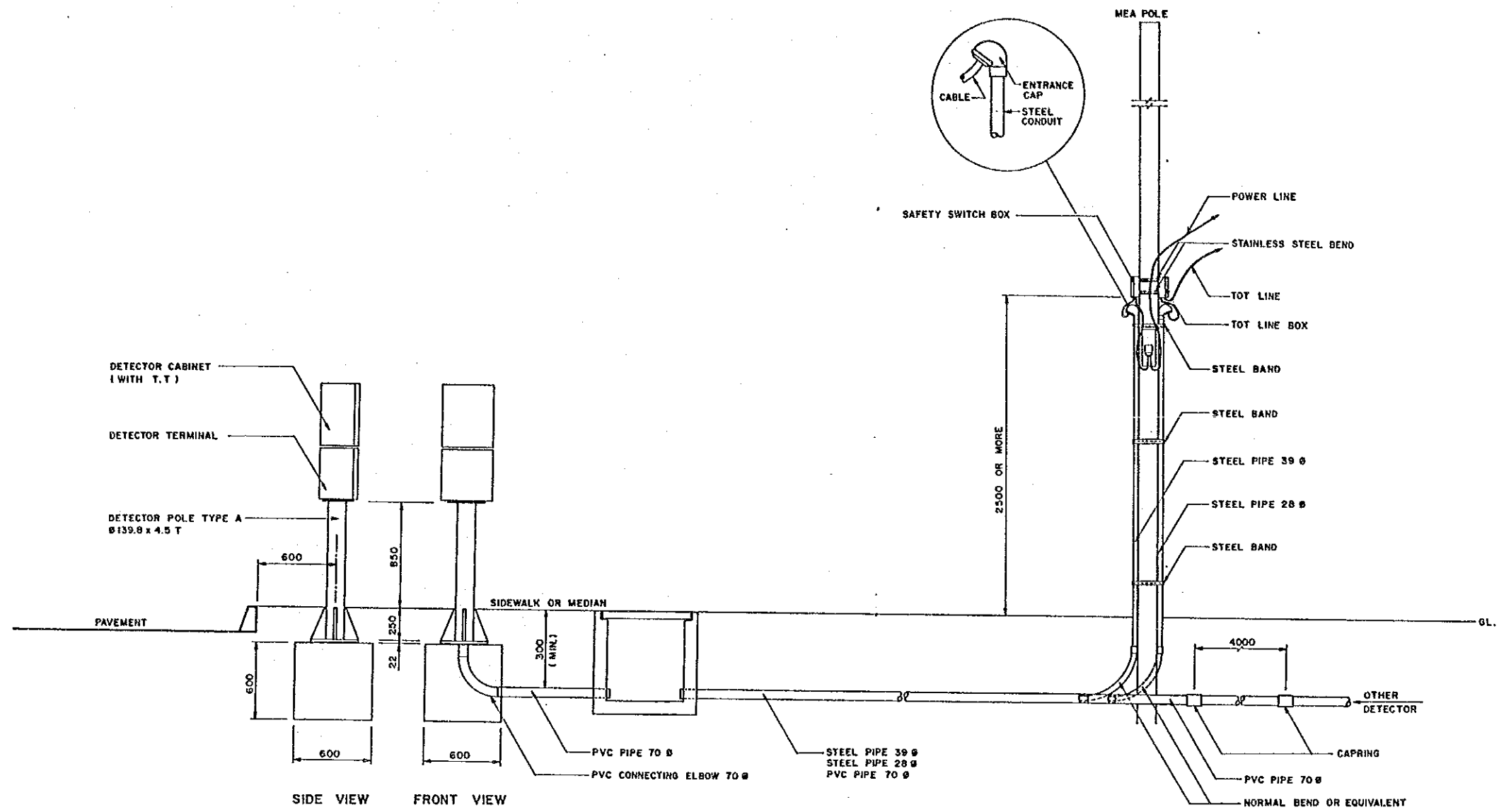

LAYOUT OF TOT LINE SWITCH AND FUSE PD BOARD

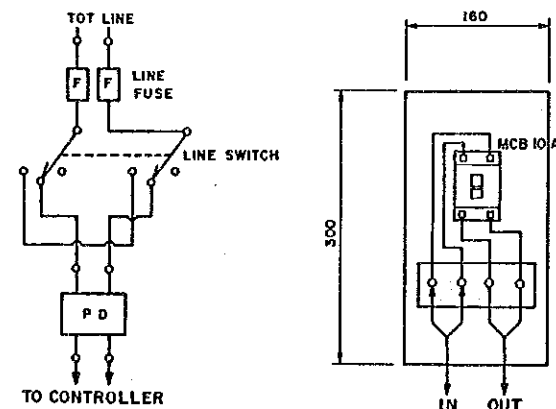

LAYOUT OF POWER SUPPLY SAFETY SWITCH BOX

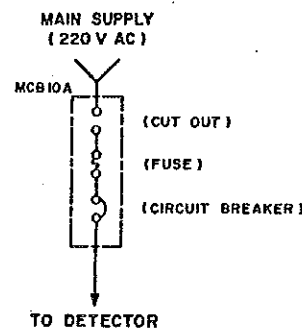

BANGKOK AREA TRAFFIC CONTROL SYSTEM PROJECT : STAGE I			
MOUNTING FACILITY OF DETECTOR CABINET TYPE 2 (LOOP TYPE)		Submitted By :	Approved By :
		Jiro Kodera JICA Study Team Leader	Boonyawat Tiptux BMA Study Team Leader
JICA Japan International Cooperation Agency		Designed By :	Checked By :
		Yasuo Hoshikuma JICA Study Member	TED, BMA
Code	Revision	Date	Initial
Associated Plan No. :		Scale	Drawing NR 1219
		Date SEPTEMBER '90	Total 20 / 43

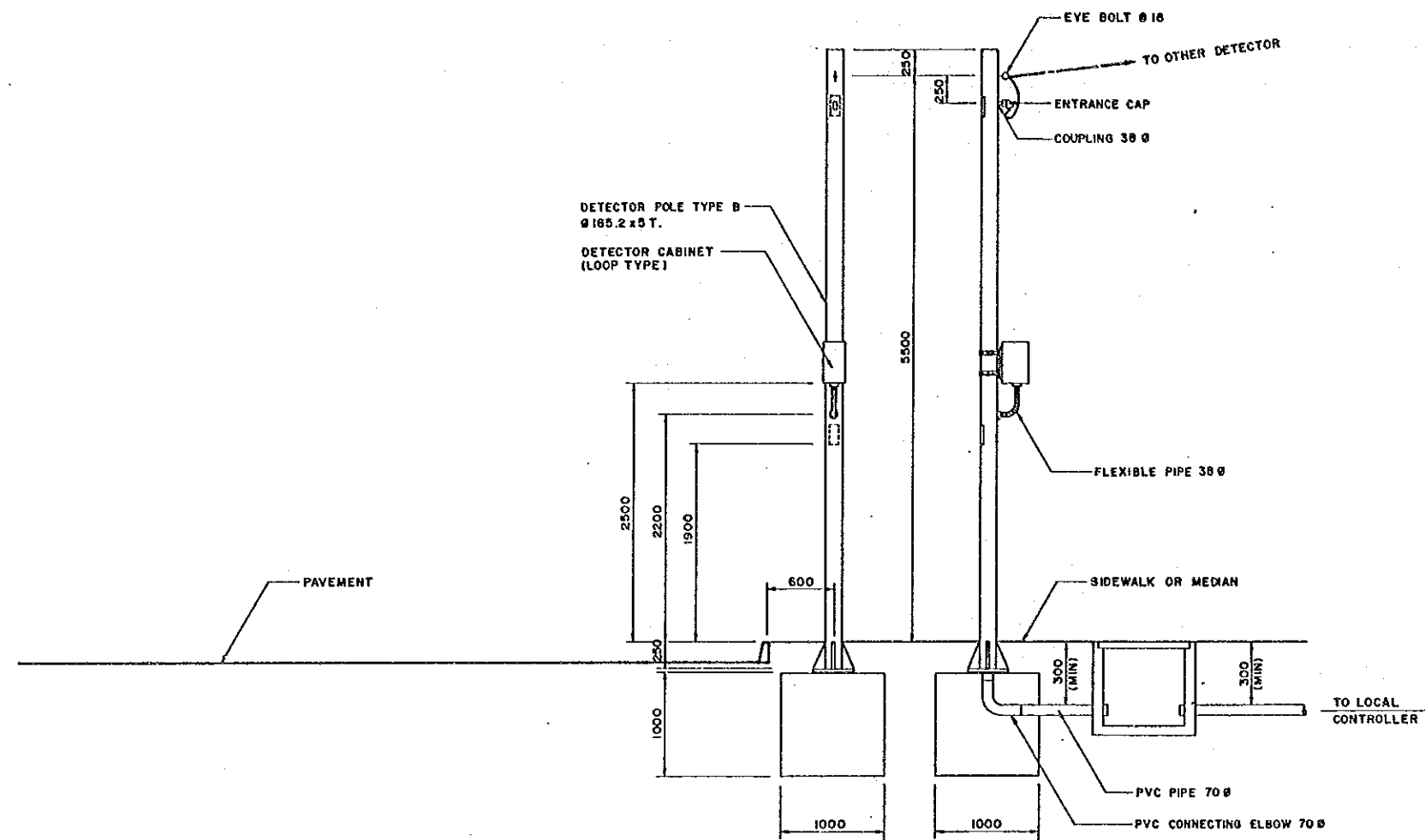

				BANGKOK AREA TRAFFIC CONTROL SYSTEM PROJECT : STAGE I			
				MOUNTING FACILITY OF DETECTOR CABINET TYPE 3 (LOOP TYPE)		Submitted By :	Approved By :
						Juno Madara JICA Study Team Leader	Boonyawat Tiptua BMA Study Team Leader
						Designed By :	Checked By :
						Yasuo Habeshima JICA Study Member	 TED, BMA
Code	Revision	Date	Initial	JICA	BMA	Scale	Drawing No
Associated Plan No. :				Japan International Cooperation Agency	Bangkok Metropolitan Administration	Date	1220
						SEPTEMBER '90	Total 21 / 43

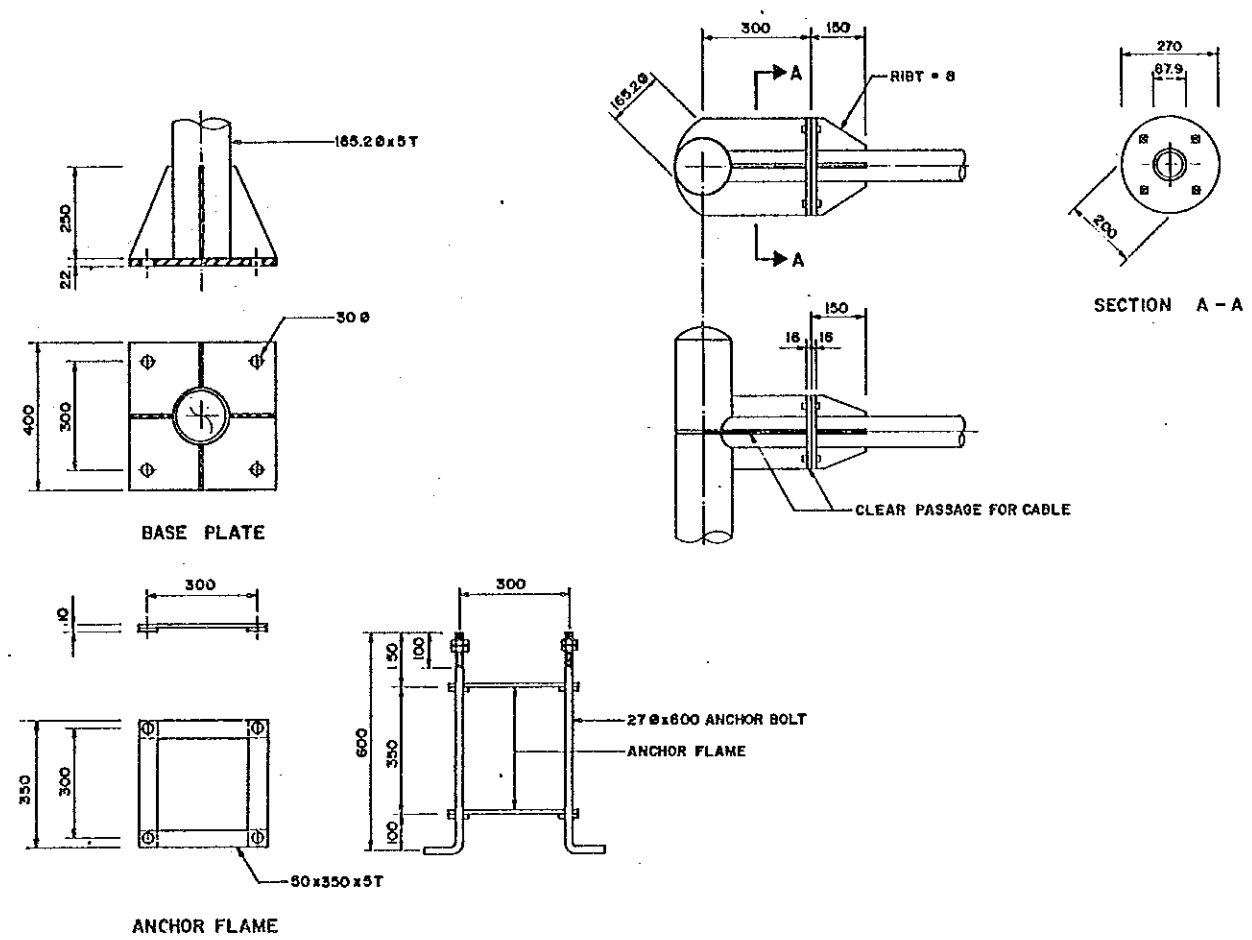
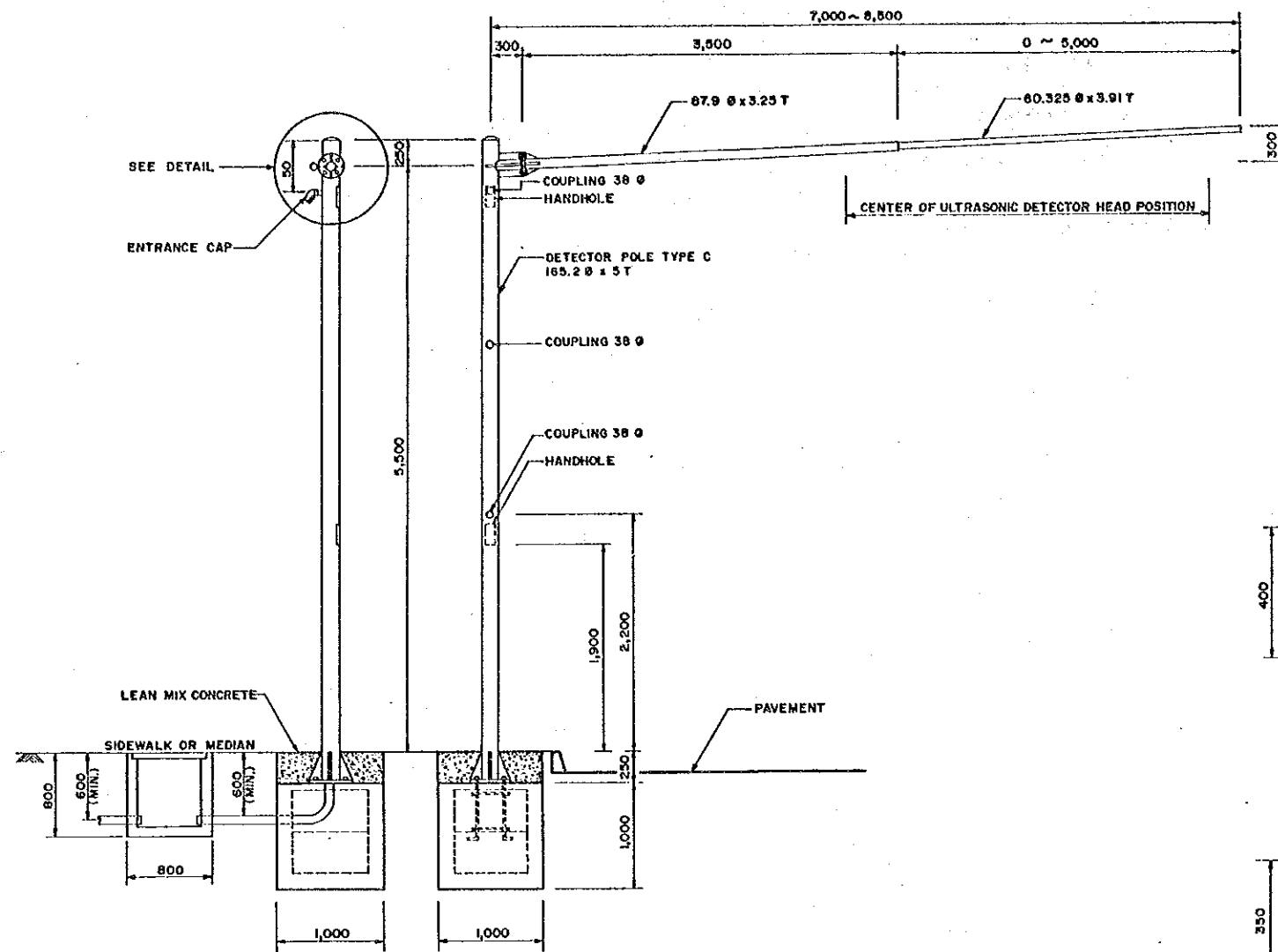

DETAILED FRONT ELEV. OF POST

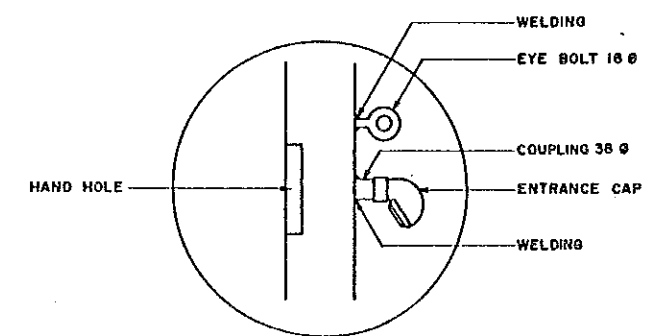

				BANGKOK AREA TRAFFIC CONTROL SYSTEM PROJECT : STAGE I			
				ULTRASONIC DETECTOR INSTALLATION PLAN (MAST ARM TYPE)		Submitted By :	Approved By :
						Jiro Kodera JICA Study Team Leader	Boonyawat Tiptus BMA Study Team Leader
						Designed By :	Checked By :
						Yasuo Nabeshima JICA Study Member	TED_BMA
Code	Revision	Date	Initial	JICA	BMA	Scale	Drawing No
Associated Plan No. :				Japan International Cooperation Agency	Bangkok Metropolitan Administration	Date	1221
						SEPTEMBER '90	Total 22 / 43

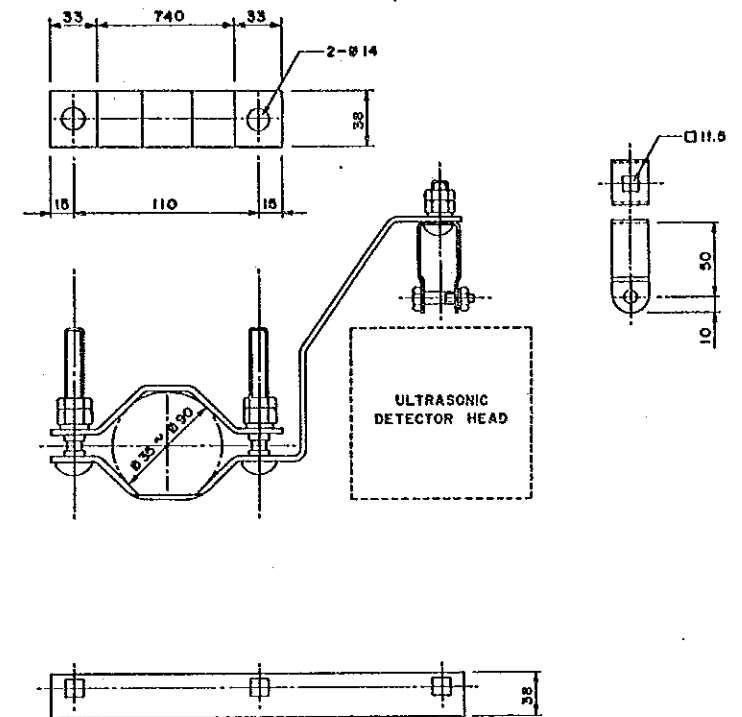
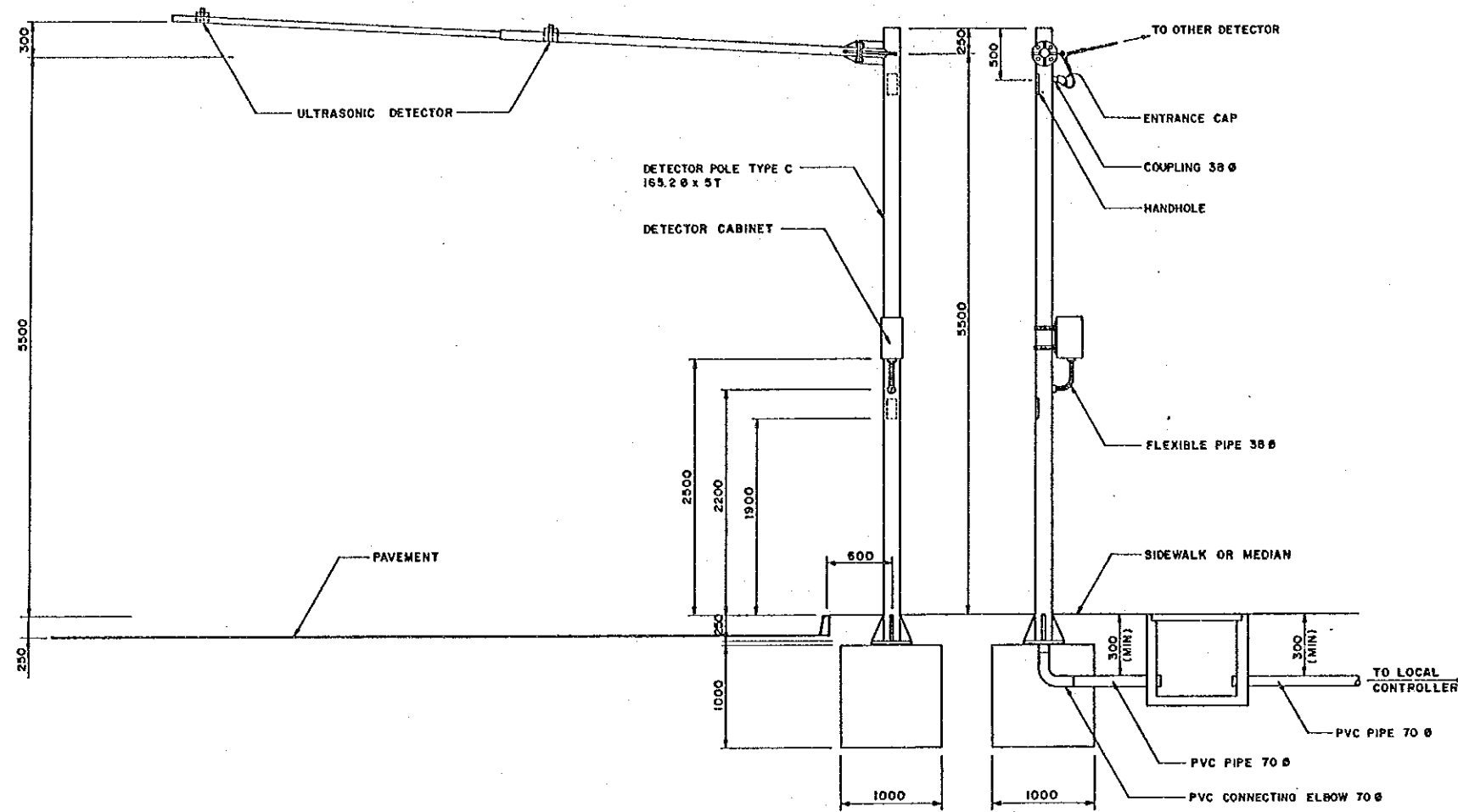

BANGKOK AREA TRAFFIC CONTROL SYSTEM PROJECT : STAGE I			
MOUNTING FACILITY OF DETECTOR CABINET TYPE 4 (ULTRASONIC TYPE)		Submitted By :	Approved By :
		Jure Kodera JICA Study Team Leader	Boonyawat Tiptus BMA Study Team Leader
Code Revision Date Initial		Designed By :	Checked By :
		Yasue Nabeshima JICA Study Member	TED, BMA
Associated Plan No. :		Scale	Drawing No. 1222
JICA Japan International Cooperation Agency		BMA Bangkok Metropolitan Administration	Date SEPTEMBER '90 Total 23 / 43

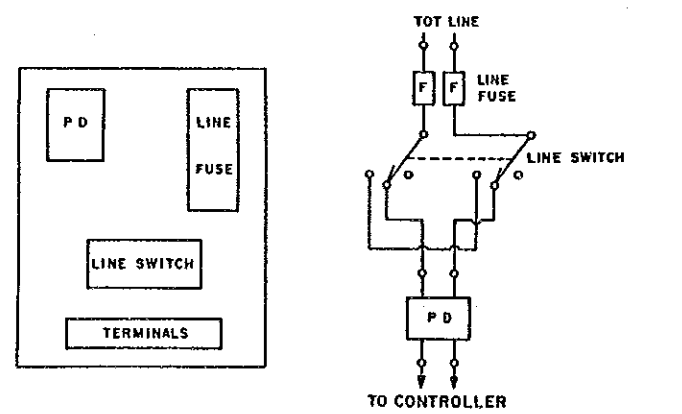
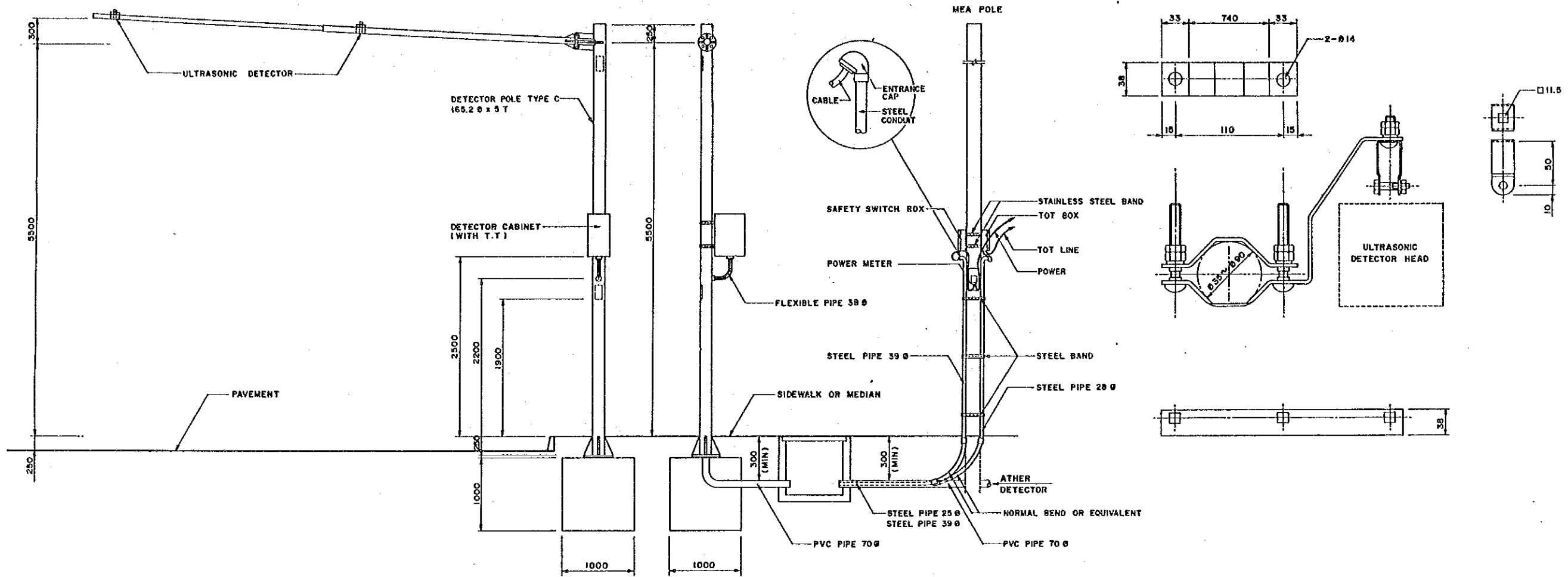

LAYOUT OF TOT LINE SWITCH AND FUSE PD BOARD

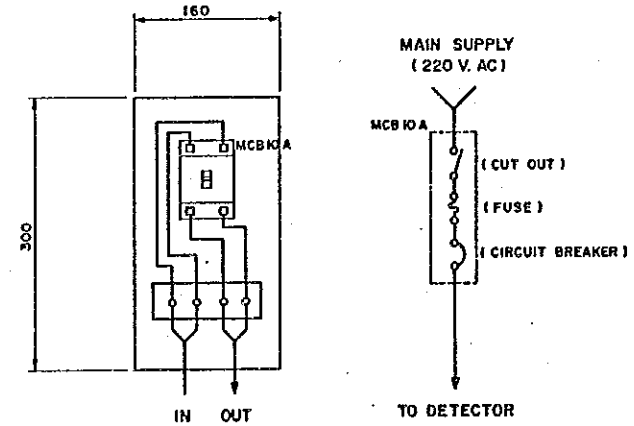

LAYOUT OF POWER SUPPLY SAFETY SWITCH BOX

BANGKOK AREA TRAFFIC CONTROL SYSTEM PROJECT : STAGE I			
MOUNTING FACILITY OF DETECTOR CABINET TYPE B (ULTRASONIC TYPE)		Submitted By : Juro Kodera JICA Study Team Leader	Approved By : Boonyawat Tiptua BMA Study Team Leader
		Designed By : Yasuo Hasehima JICA Study Member	Checked By : TED, BMA
Code	Revision	Date	Initial
Associated Plan No. :	JICA Japan International Cooperation Agency	BMA Bangkok Metropolitan Administration	Scale Drawing No. : 1223 Date SEPTEMBER '90 Total 24 / 43

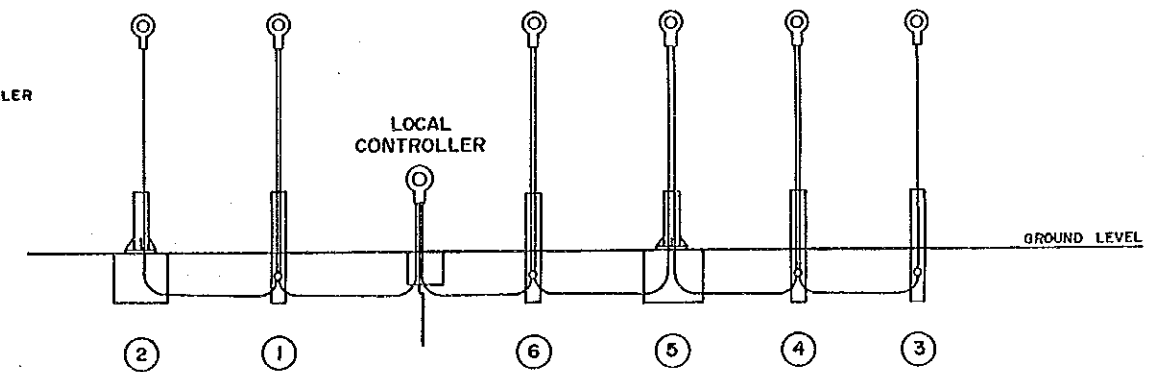
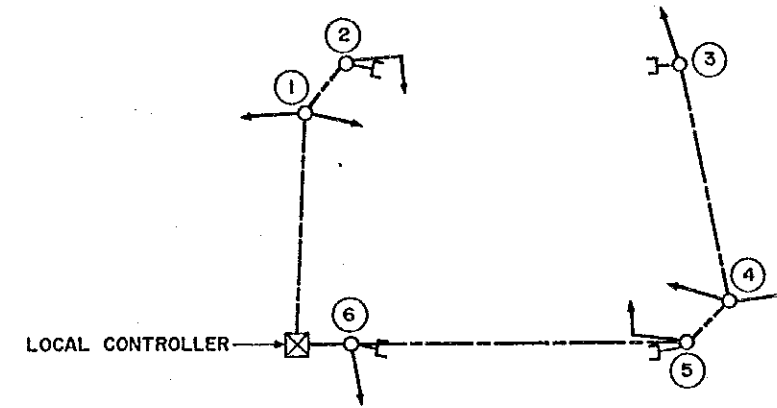
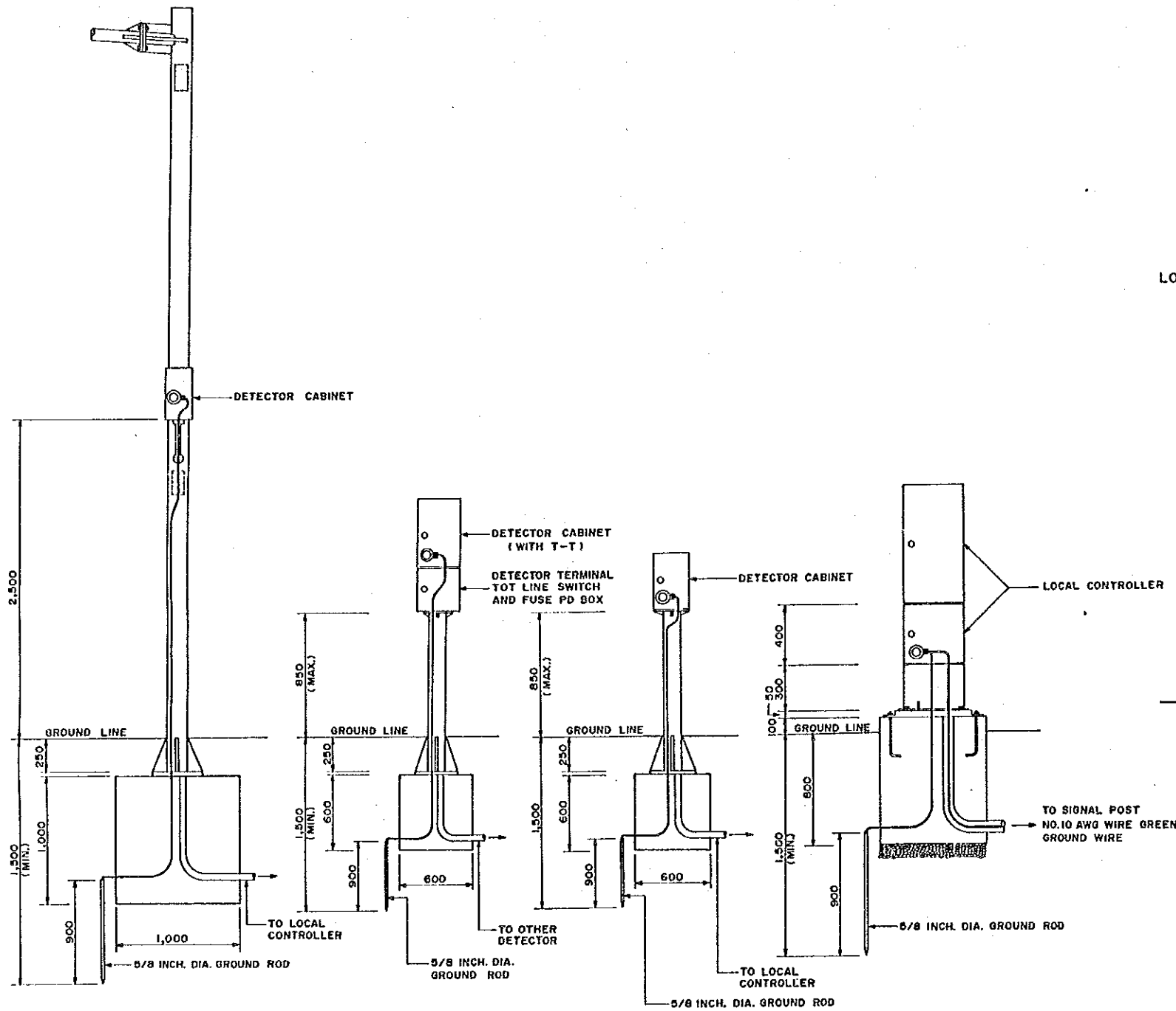

NOTE :
TO BE CONNECTED WITH STEEL POLES
OR LOCAL CONTROLLER'S CABINET

BANGKOK AREA TRAFFIC CONTROL SYSTEM PROJECT : STAGE I			
Associated Plan No. :		GROUNDING SYSTEM FOR LOCAL CONTROLLER AND DETECTOR CABINET	
Code		Submitted By : Juro Kodera JICA Study Team Leader	Approved By : Boonyawat Tiplux BMA Study Team Leader
Revision		Designed By : Yasuo Nabeshima JICA Study Member	Checked By : TED, BMA
Date		Scale	Drawing No. 1224
Initial		Date : SEPTEMBER '90	Total 25 / 43
JICA Japan International Cooperation Agency		BMA Bangkok Metropolitan Administration	

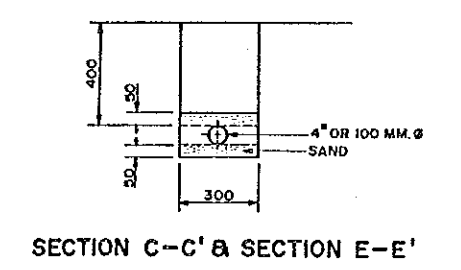
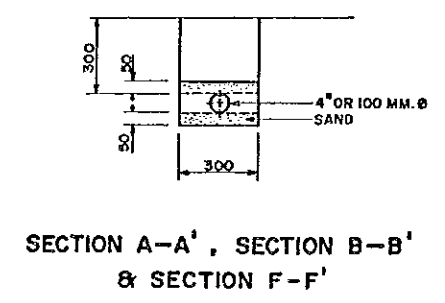
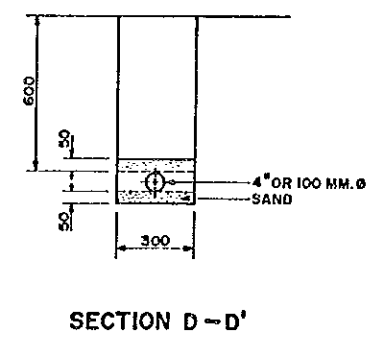
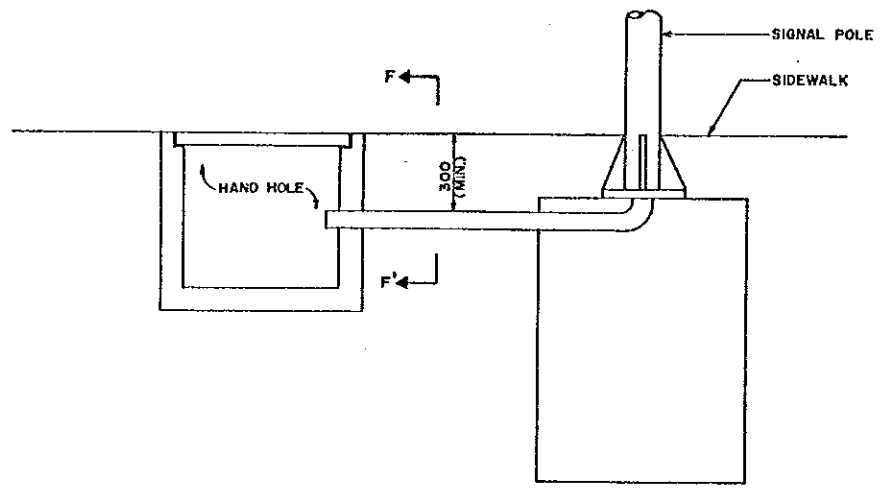
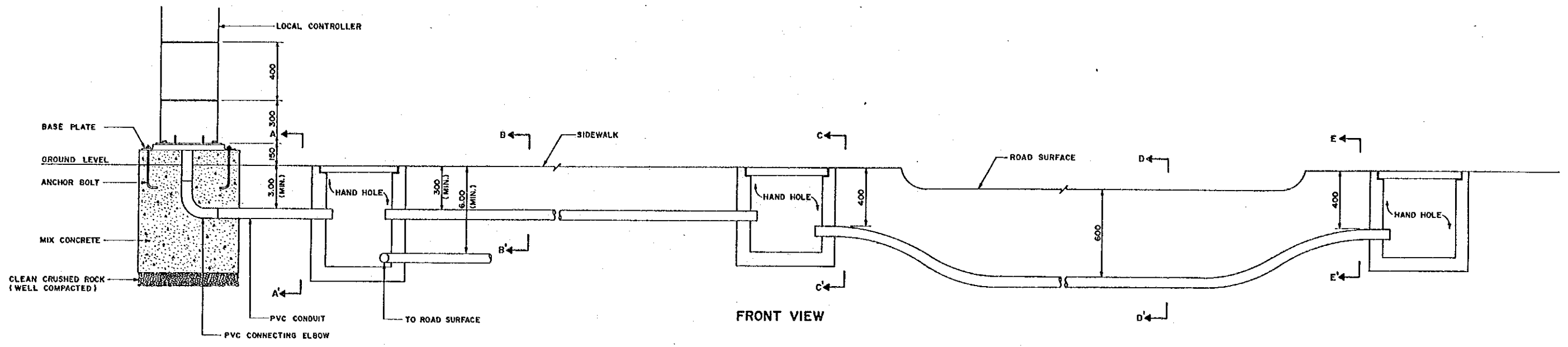

				BANGKOK AREA TRAFFIC CONTROL SYSTEM PROJECT : STAGE I			
				UNDERGROUND CONDUIT INSTALLATION PLAN		Submitted By :	Approved By :
						Jiro Kodera <small>JICA Study Team Leader</small>	Boonyawat Tiptua <small>BMA Study Team Leader</small>
						Designed By :	Checked By :
						Yasuo Mabeshima <small>JICA Study Member</small>	YED, BMA
Code	Revision	Date	Initial	JICA	BMA	Scale	Drawing No
Associated Plan No. :				Japan International Cooperation Agency	Bangkok Metropolitan Administration	Date	Total
						SEPTEMBER '90	1225 26 / 43

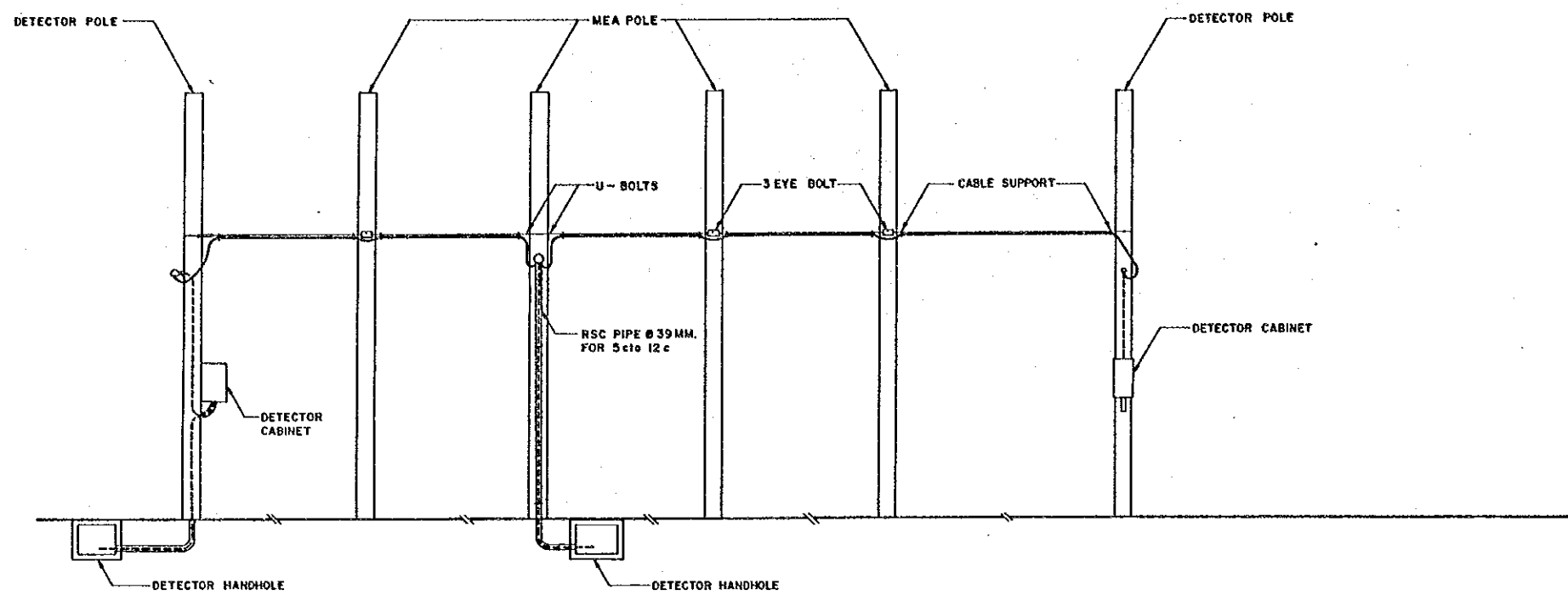

NORMAL INSTALLATION

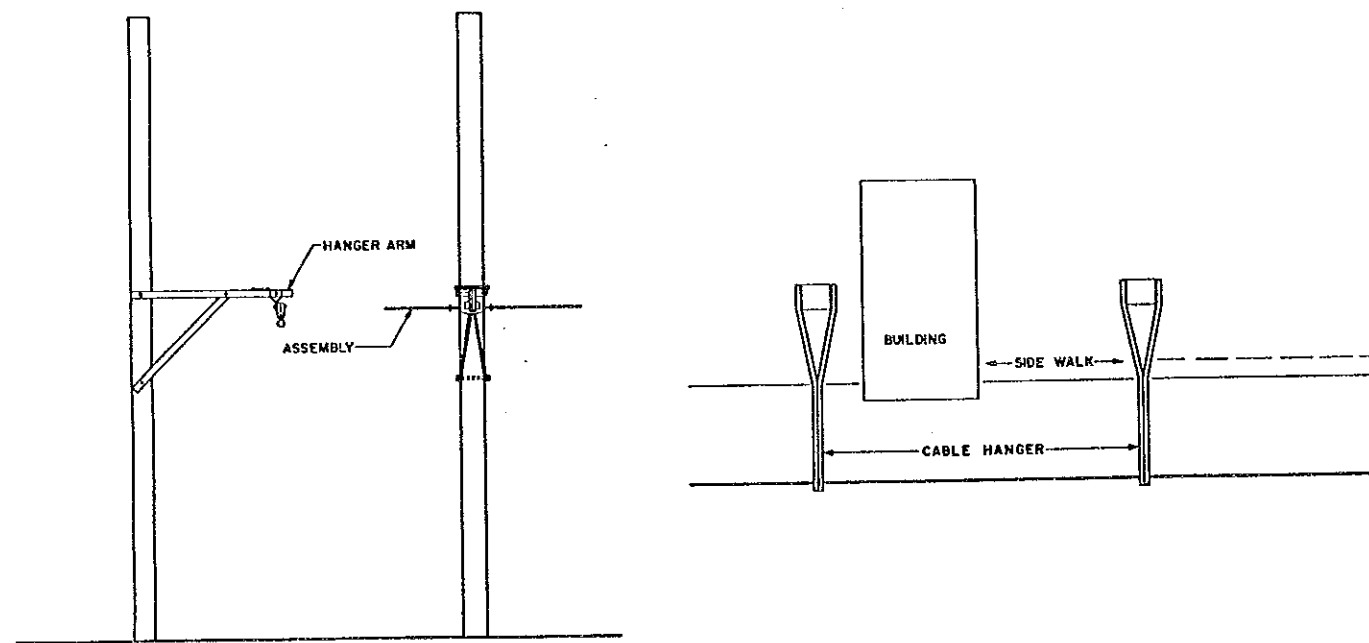
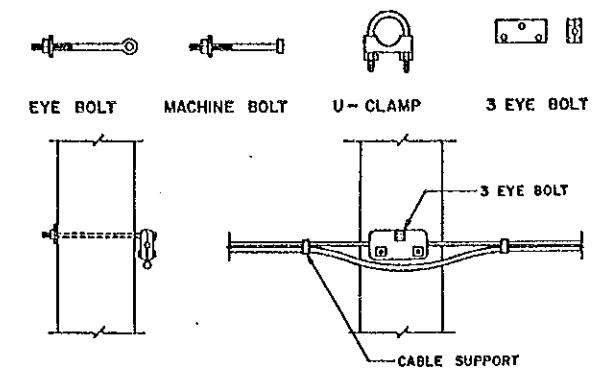

SPECIAL INSTALLATION

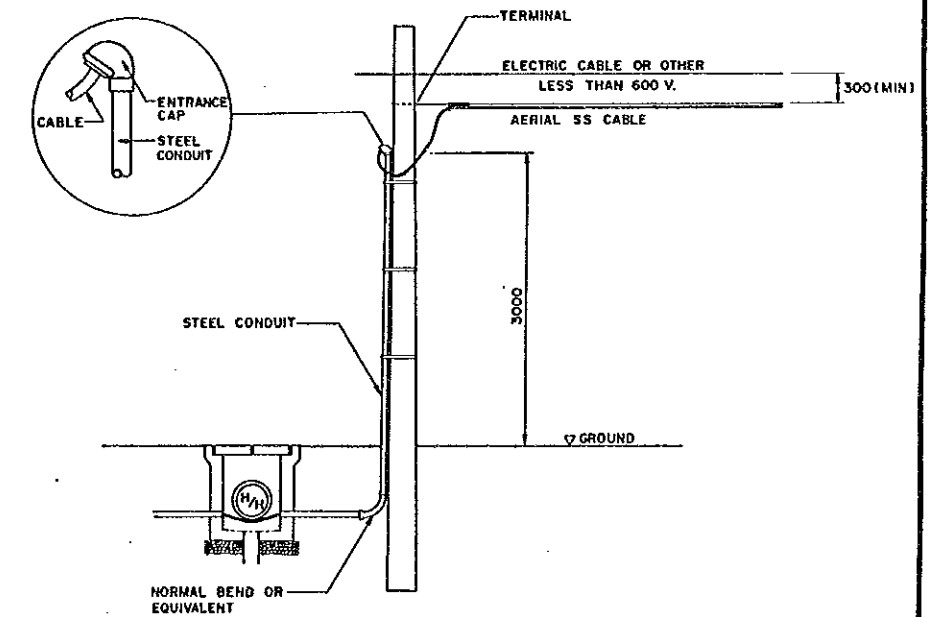

Code				Revision				Date				Initial			
Associated Plan No. :				JICA				BMA				Scale			
				Japan International Cooperation Agency				Bangkok Metropolitan Administration				Drawing No 1226			
				Submitted By :				Approved By :				Date			
				Jiro Kodera JICA Study Team Leader				Boonyawat Tiptus BMA Study Team Leader				SEPTEMBER '00			
				Designed By :				Checked By :				Total			
				Yasuo Nishishima JICA Study Member				TED, BMA				27/43			

BANGKOK AREA TRAFFIC CONTROL SYSTEM PROJECT : STAGE I

AERIAL - UNDERGROUND CABLE CONNECTION DETAIL

JICA
Japan International
Cooperation Agency

BMA
Bangkok Metropolitan
Administration

Scale
Date SEPTEMBER '00

Drawing No 1226
Total 27/43

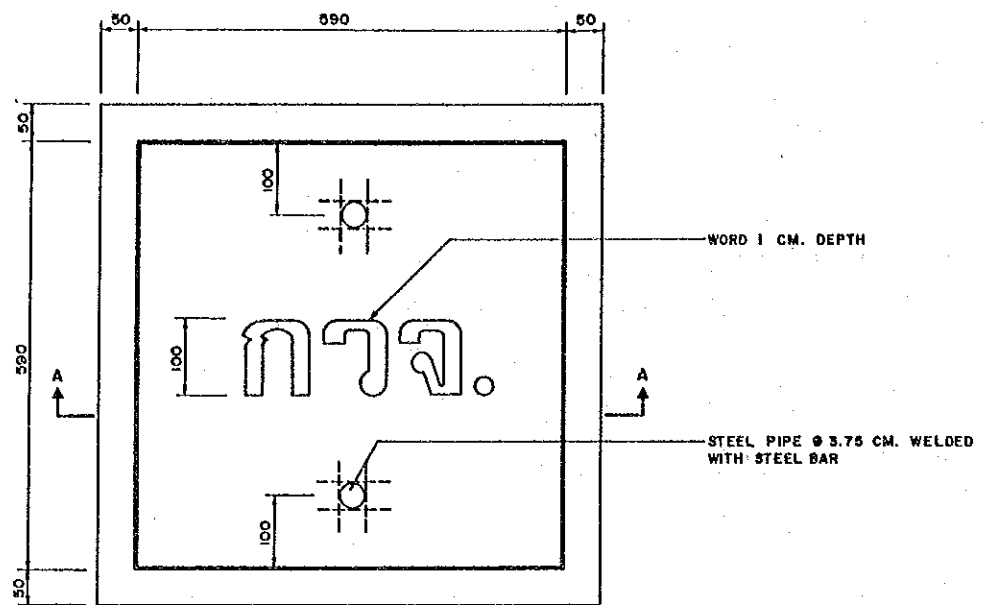

TOP VIEW

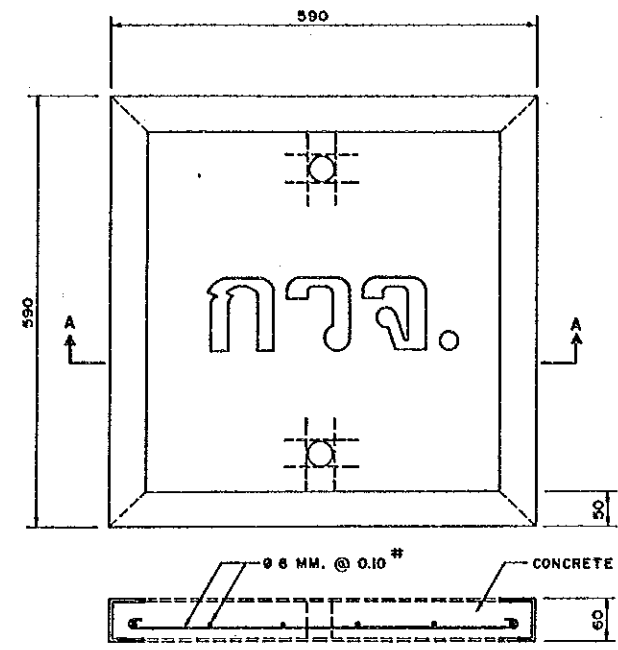

SECTION A-A
DETAIL OF COVER

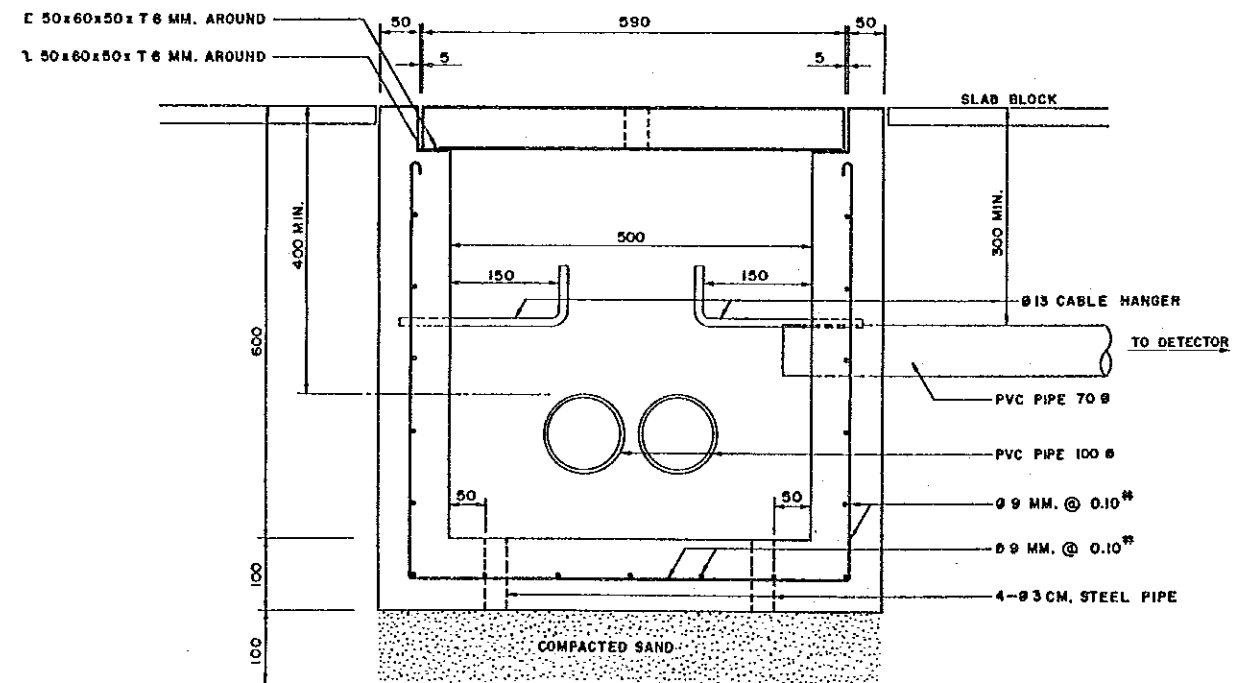

SECTION THRU A-A

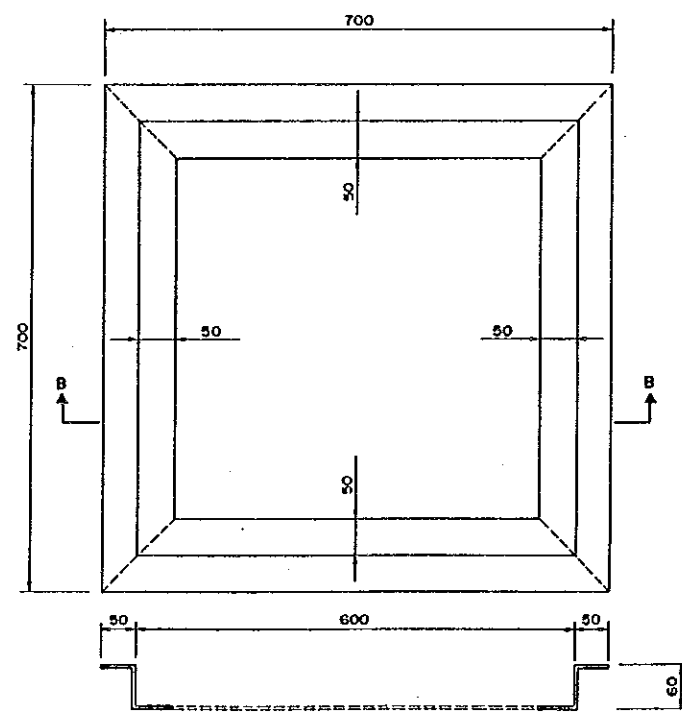

SECTION B-B
STEEL FRAME AROUND
FOR REINFORCED HAND HOLE

BANGKOK AREA TRAFFIC CONTROL SYSTEM PROJECT : STAGE I			
HANDHOLE DESIGN TYPE C		Submitted By :	Approved By :
		Juro Kodera JICA Study Team Leader	Boonyawat Tiptue BMA Study Team Leader
JICA Japan International Cooperation Agency		Designed By :	Checked By :
		Yasuo Mabeshima JICA Study Member	YED, BMA
Code	Revision	Date	Initial
Associated Plan No. :			
BMA Bangkok Metropolitan Administration		Scale	Drawing No
		Date	Total
		SEPTEMBER '90	1227 28 / 43

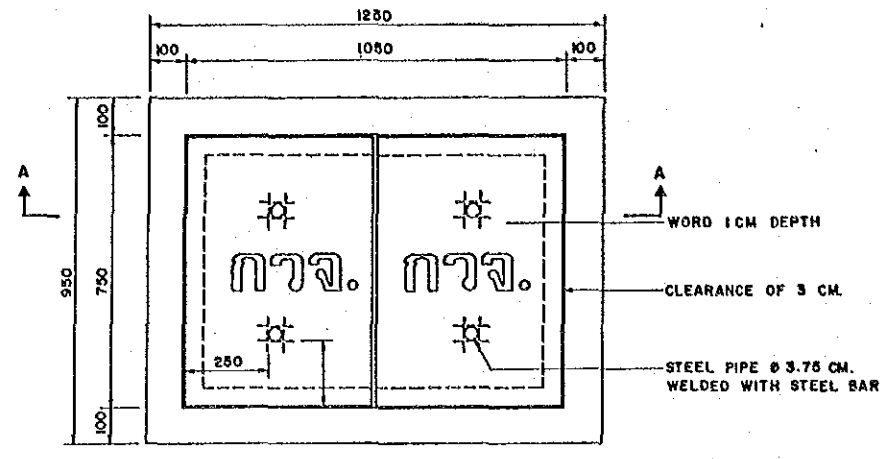

TOP VIEW

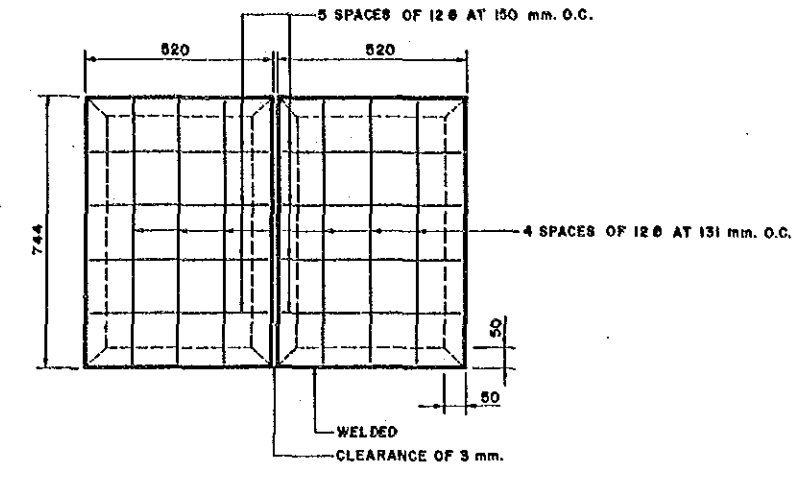

DETAIL OF COVER

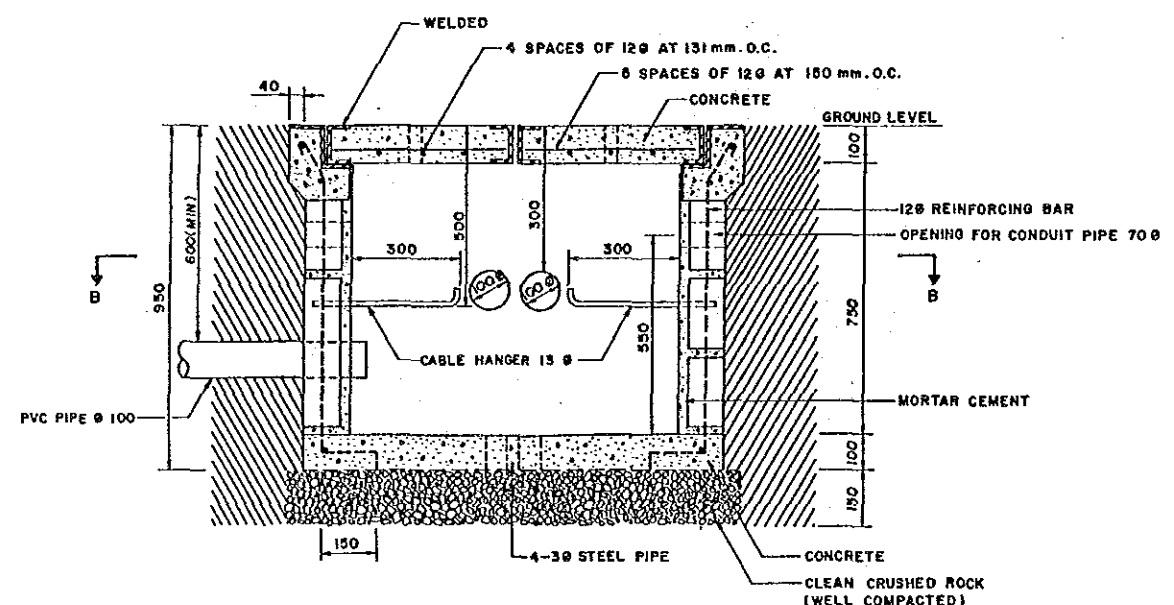

SECTION THRU A-A

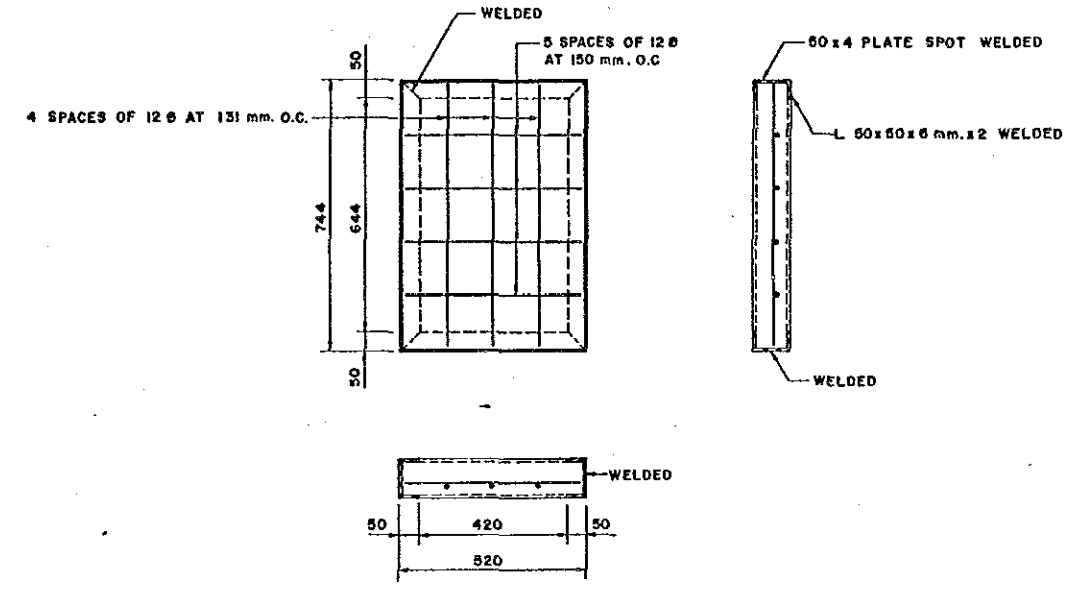

STEEL FRAME ALL AROUND FOR REINFORCED CONCRETE COVER

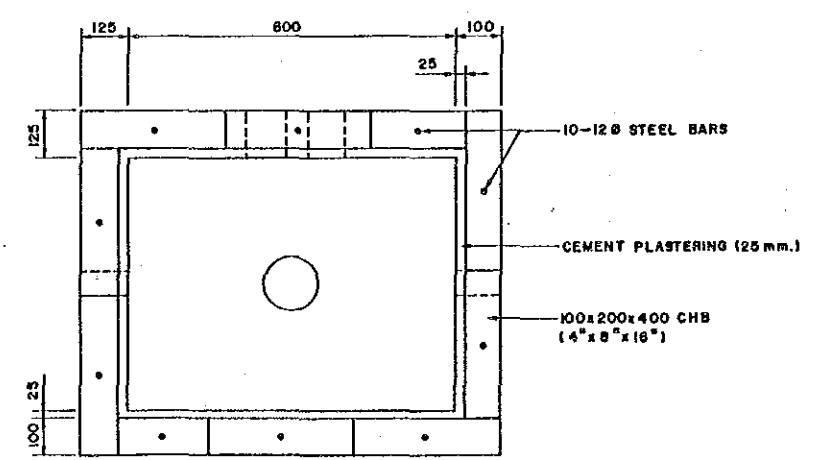

SECTION THRU B-B

BANGKOK AREA TRAFFIC CONTROL SYSTEM PROJECT : STAGE I			
Associated Plan No. :		HANDHOLE DESIGN TYPE D	
		Submitted By : Jiro Kodera JICA Study Team Leader	Approved By : Boonyawat Tiplus BMA Study Team Leader
Code		Designed By : Yasuo Nobushima JICA Study Member	Checked By : YED, BMA
		JICA Japan International Cooperation Agency	BMA Bangkok Metropolitan Administration
Scale		Date	Drawing No
Plan No. :		SEPTEMBER '90	1228
		Total	29 / 43

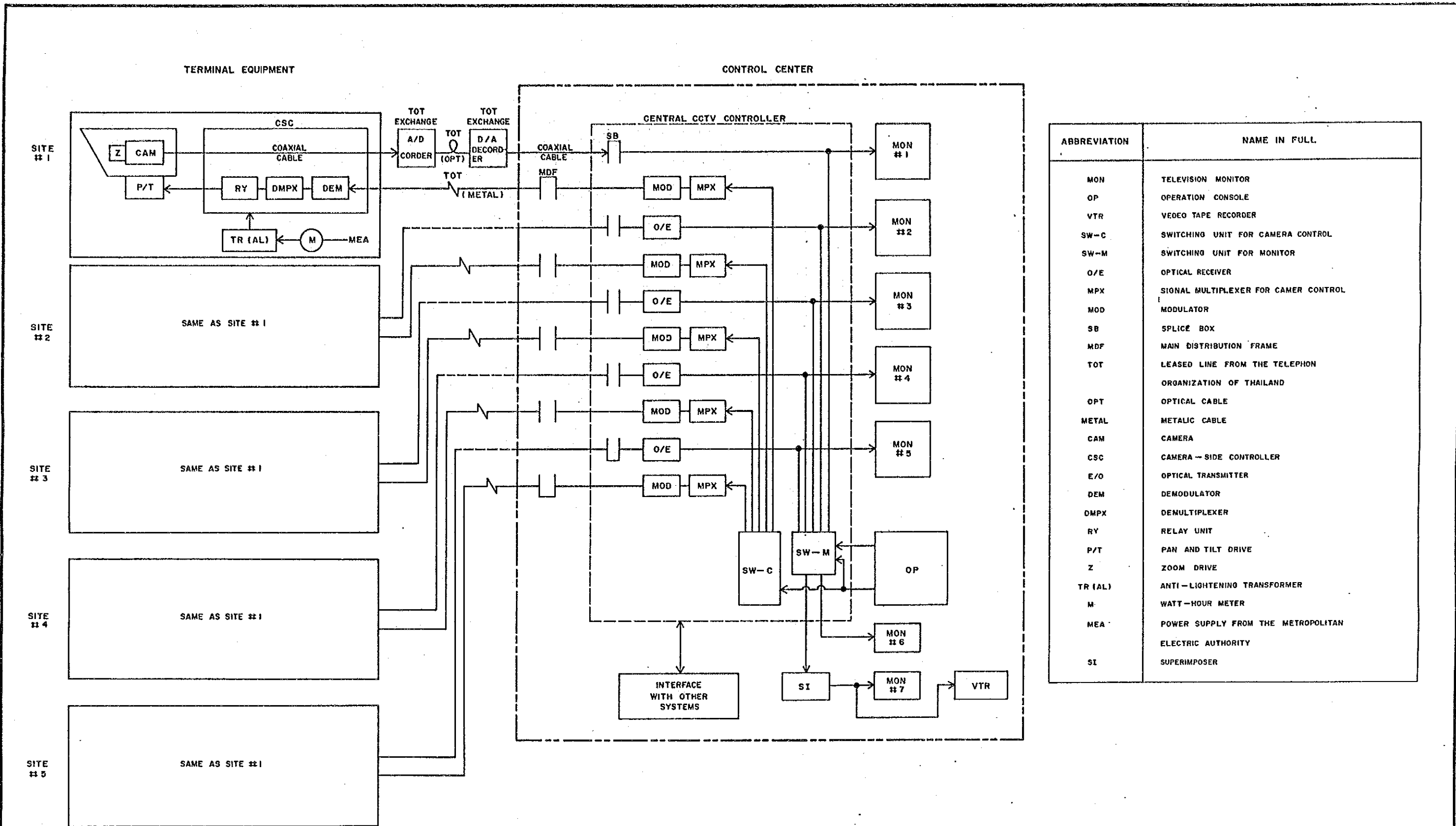

ABBREVIATION	NAME IN FULL
MON	TELEVISION MONITOR
OP	OPERATION CONSOLE
VTR	VIDEO TAPE RECORDER
SW-C	SWITCHING UNIT FOR CAMERA CONTROL
SW-M	SWITCHING UNIT FOR MONITOR
O/E	OPTICAL RECEIVER
MPX	SIGNAL MULTIPLEXER FOR CAMER CONTROL
MOD	MODULATOR
SB	SPLICE BOX
MDF	MAIN DISTRIBUTION FRAME
TOT	LEASED LINE FROM THE TELEPHON ORGANIZATION OF THAILAND
OPT	OPTICAL CABLE
METAL	METALIC CABLE
CAM	CAMERA
CSC	CAMERA -- SIDE CONTROLLER
E/O	OPTICAL TRANSMITTER
DEM	DEMODULATOR
DMPX	DEMULTIPLEXER
RY	RELAY UNIT
P/T	PAN AND TILT DRIVE
Z	ZOOM DRIVE
TR (AL)	ANTI-LIGHTENING TRANSFORMER
M	WATT-HOUR METER
MEA	POWER SUPPLY FROM THE METROPOLITAN ELECTRIC AUTHORITY
SI	SUPERIMPOSER

CCTV SYSTEM CONFIGURATION DIAGRAM

				BANGKOK AREA TRAFFIC CONTROL SYSTEM PROJECT : STAGE I			
				CCTV SYSTEM CONFIGURATION DIAGRAM		Submitted By : Juro Kodera JICA Study Team Leader	Approved By : Boonyawat Tiptus BMA Study Team Leader
						Designed By : Yasuo Nabeshima JICA Study Member	Checked By : TED.BMA
Code	Revision	Date	Initial	JICA Japan International Cooperation Agency	BMA Bangkok Metropolitan Administration	Scale	Drawing No. 1301
Associated Plan No. :						Date SEPTEMBER '90	Total 30/43

RATCHADAPHISEK -- ASOK DIN DAENG (NO. 194)

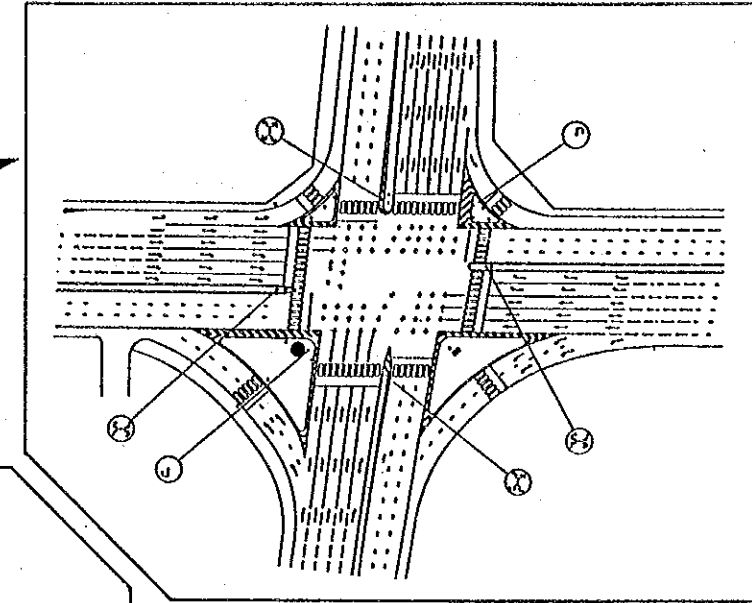

SUKHUMVIT - SOI SUKUMVIT 21 - RATCHADAPHISEK (NO. 115)

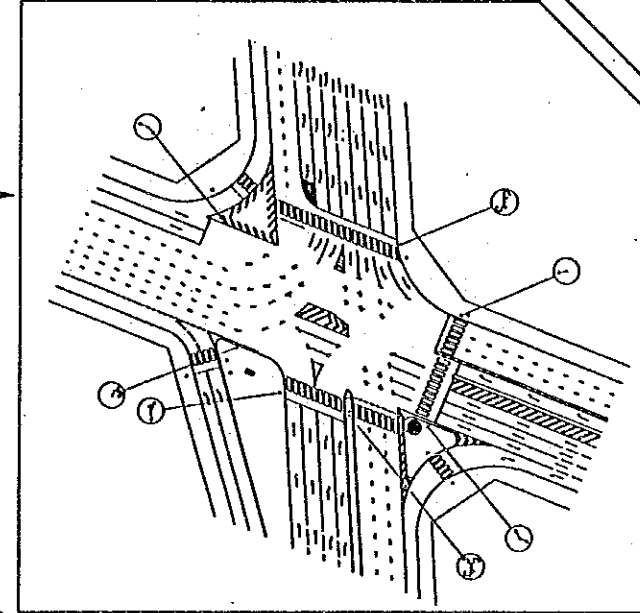

SATHON - WITTHAYU - RAMA IV (NO. 103)

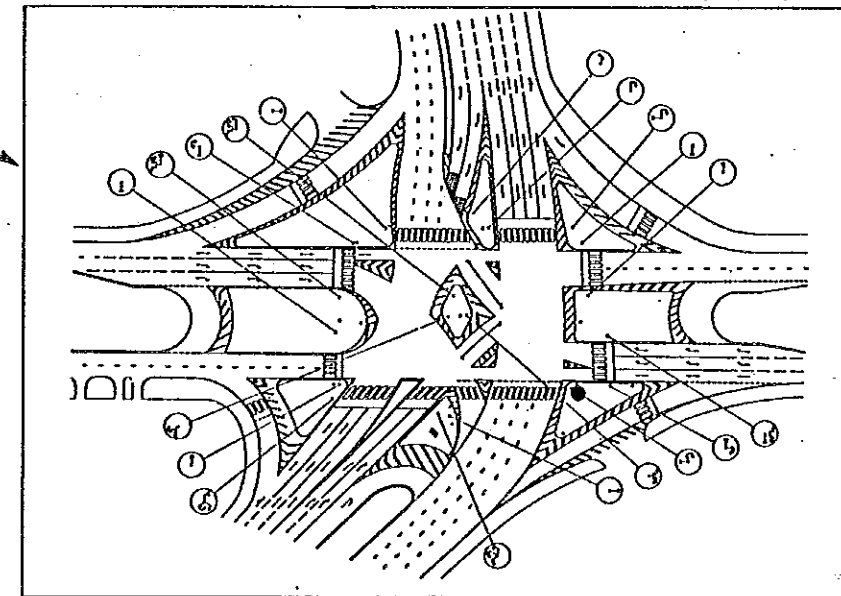

RATCHADAMNOEN KLANG -- RATCHADAMNOEN NAI (NO. 13)

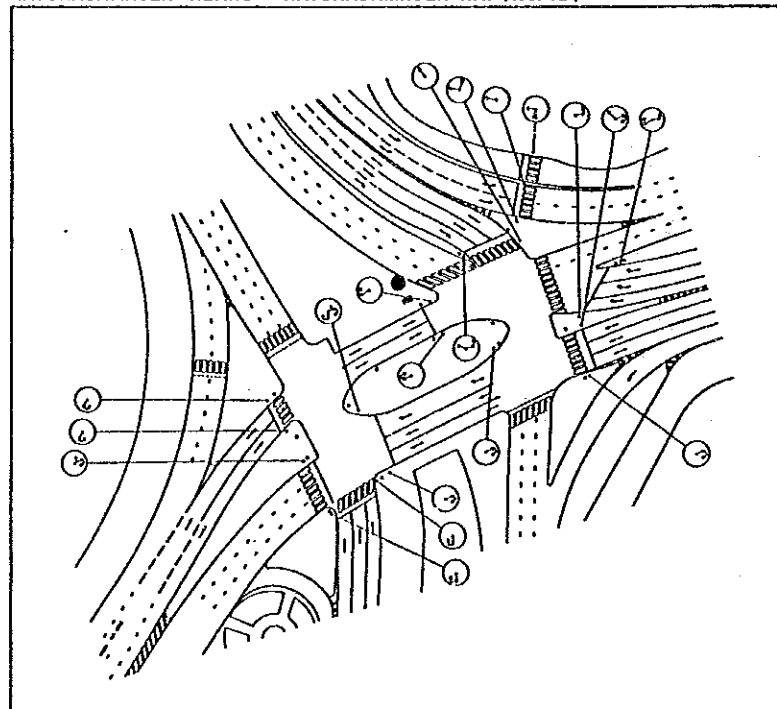

PHAYA THAI - PHETCHABURI (NO. 18)

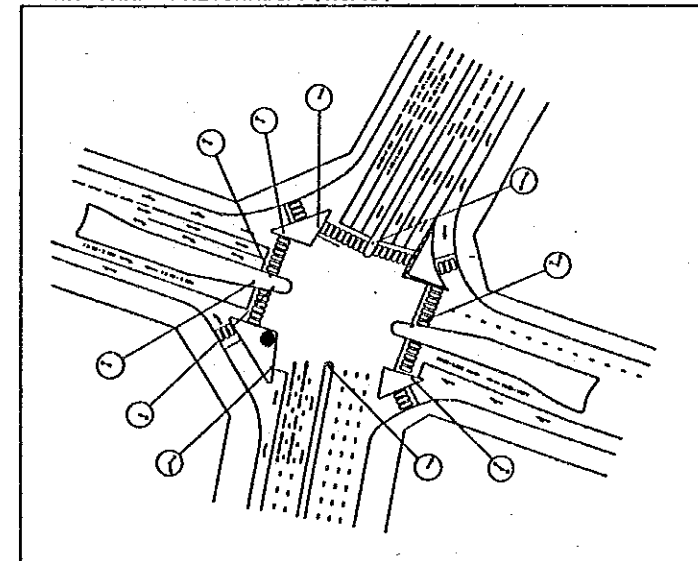

LEGEND
● CCTV LOCATION

BANGKOK AREA TRAFFIC CONTROL SYSTEM PROJECT : STAGE I

Code	Revision	Date	Initial

CCTV CAMERA LOCATIONS

JICA
Japan International
Cooperation Agency

BMA
Bangkok Metropolitan
Administration

Submitted By : Jiro Kudo JICA Study Team Leader	Approved By : Boonyawat Tiptua BMA Study Team Leader
Designed By : Yasu Hoshino JICA Study Member	Checked By : TED, BMA
Scale	Drawing No 1302
Date SEPTEMBER '90	Total 31/43

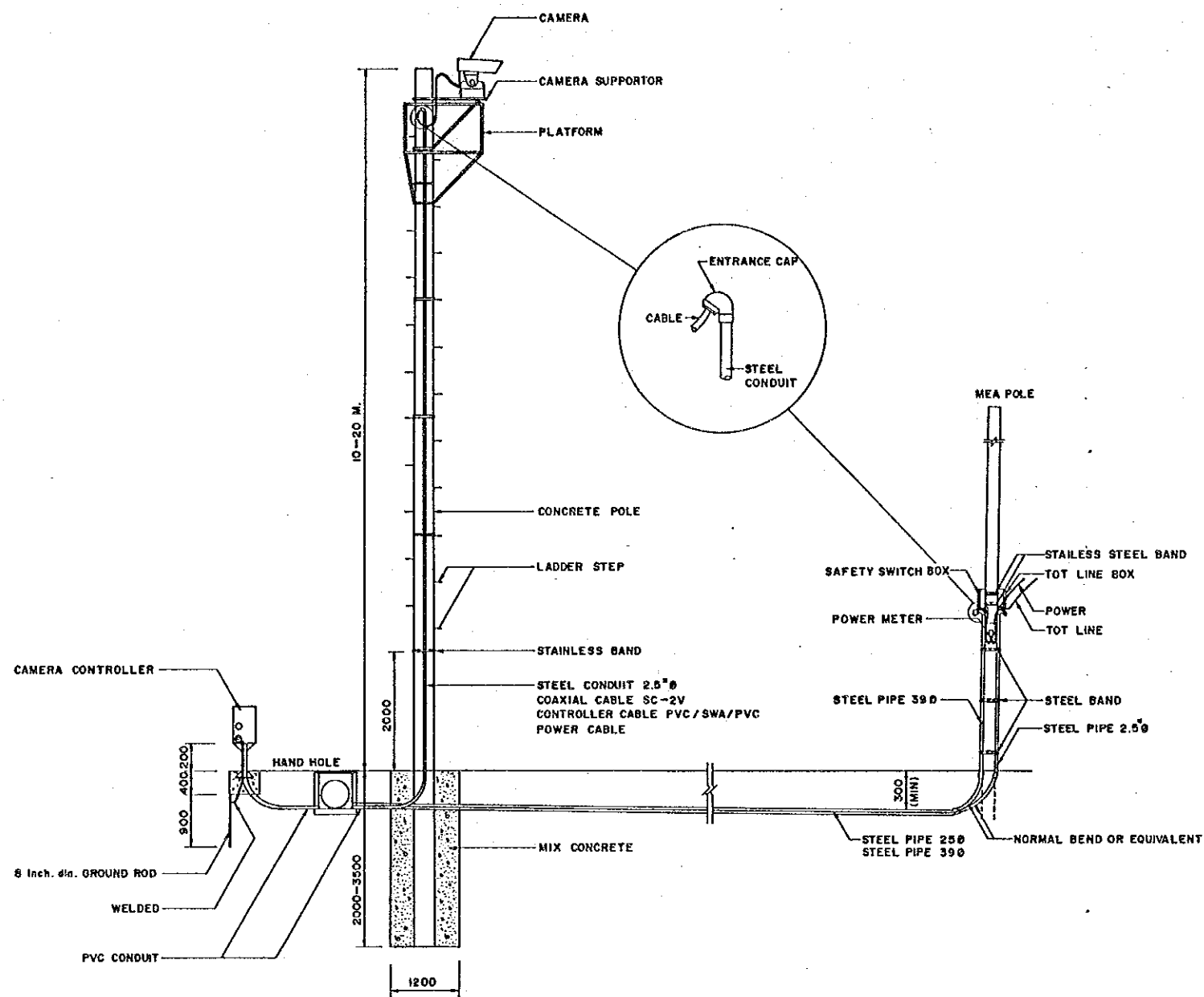

CCTV CAMERA INSTALLATION PLAN

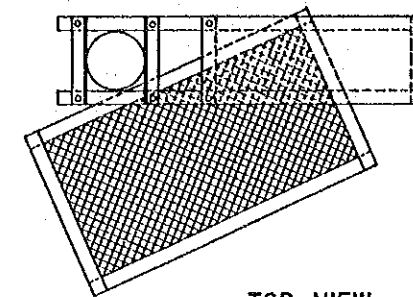

TOP VIEW

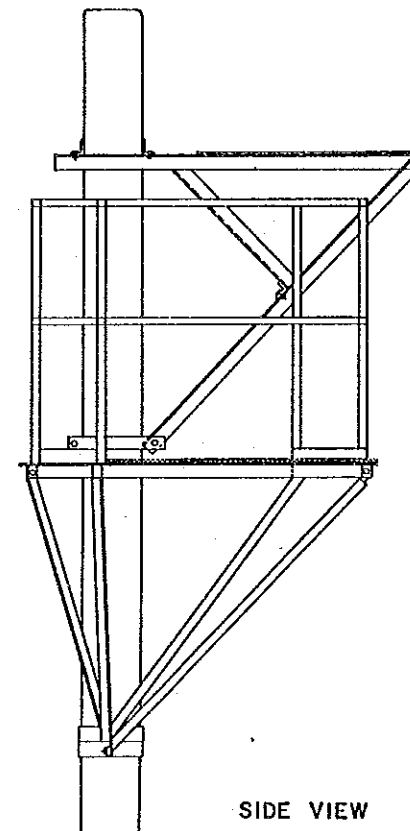

SIDE VIEW

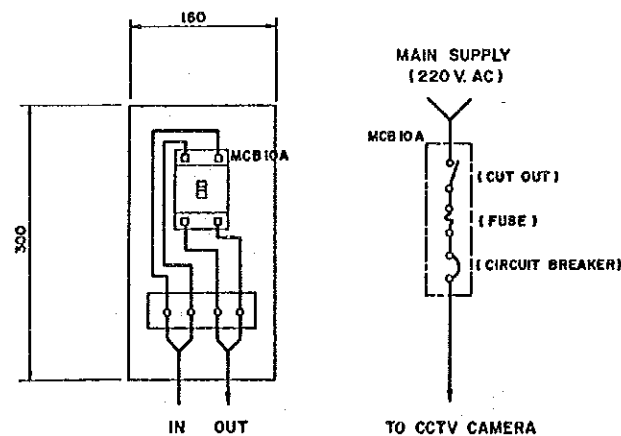
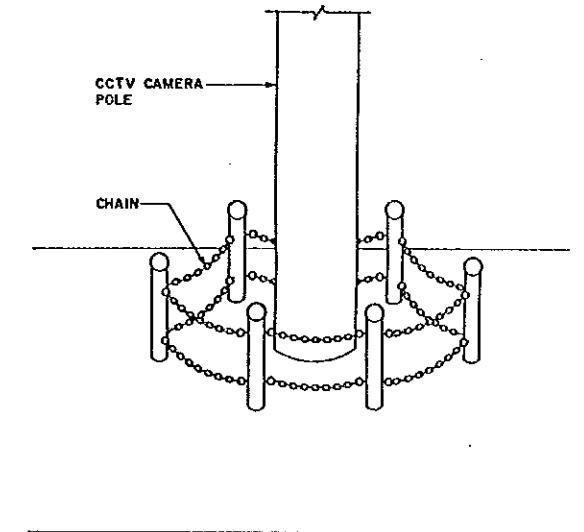

LAYOUT OF POWER SUPPLY SAFETY SWITCH BOX

CCTV PLATFORM

NOTE

DRAWINGS SHOWS THE USE OF CONCRETE MOUNTING POLE. TENDERER SHALL SUBMIT DRAWING INDICATING APPROPRIATE MOUNTING POLE AS PROPOSED.

BANGKOK AREA TRAFFIC CONTROL SYSTEM PROJECT : STAGE I			
CCTV CAMERA INSTALLATION PLAN		Submitted By : Jure Kodera JICA Study Team Leader	Approved By : Boonyawat Tiptus BMA Study Team Leader
		Designed By : Yasuo Hoshizuma JICA Study Member	Checked By : TED, BMA
Code	Revision	Date	Initl
Associated Plan No. :	JICA Japan International Cooperation Agency	BMA Bangkok Metropolitan Administration	Scale Drawing No 1303 Date SEPTEMBER '90 Total 32 / 43

TRAFFIC CONTROL CENTER

BANGKOK AREA TRAFFIC CONTROL SYSTEM PROJECT : STAGE I

LOCATION MAP

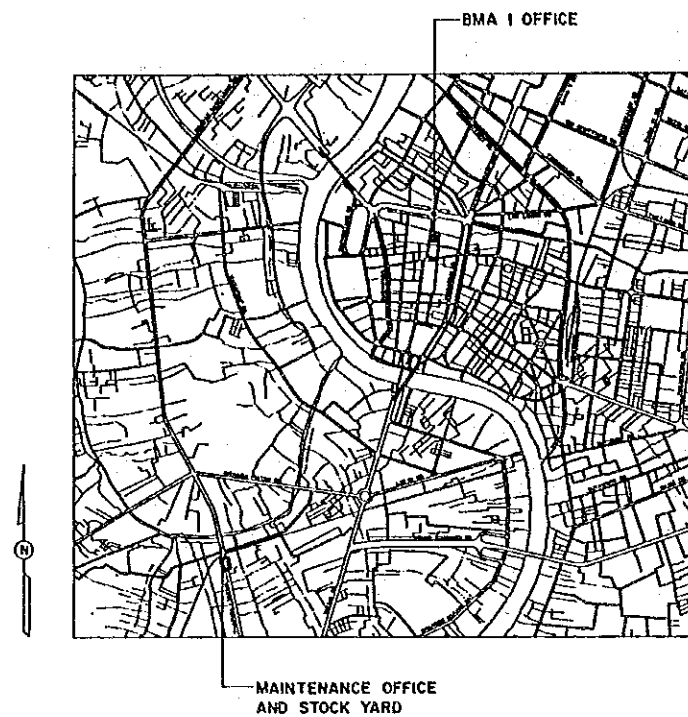

KEY PLANS

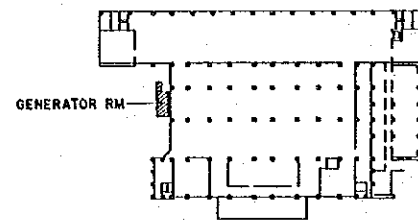

BASEMENT FLOOR
SCALE 1/1000

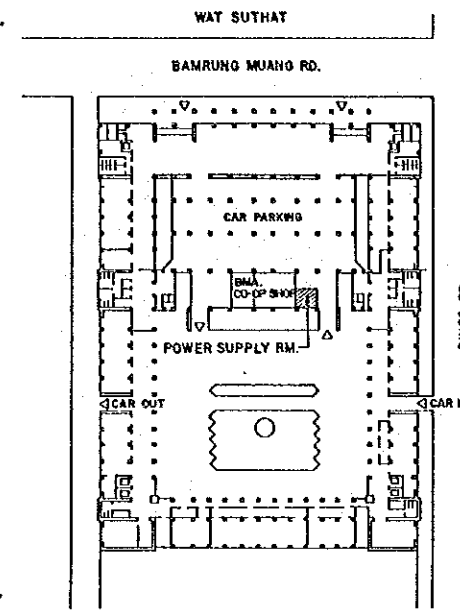

1ST FLOOR
SCALE 1/1000

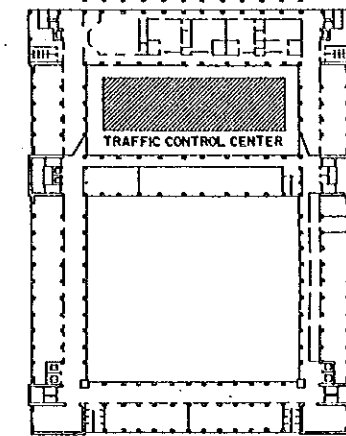

2ND FLOOR
SCALE 1/1000

ABBREVIATIONS

A	ALTERNATING CURRENT	D	DIFFUSER	H	HEADBOARD	O	ON CENTER	T	TELEPHONE
AC	AIR CONDITIONING	DBL	DOUBLE	HOW	HARDWARE	OD	OUTSIDE DIAMETER	TEMP	TEMPERATURE
ADJ	ADJACENT OR ADJUSTABLE	DET	DETAR	HWWD	HARDWOOD	OPND	OPENING	TERR	TERRAZZO
ADN	ACCESS DOOR	DA	DIAMETER	HM	HOLLOW METAL	OPP	OPPOSITE	TOIL	TOILET
AF	ADJOVE FINISH FLOOR	DAG	DIAGONAL	HFRZ	HORIZONTAL	OS	OFFSET	TYP	TYPICAL
AL	ALUMINUM	DN	DOWN	HR	HOUR	OZ	OUNCE	U	
ALT	ALTERNATE	DR	DOOR	HT	HEIGHT	P	POLYMER	UPH	UPHOLSTERY
APPROX	APPROXIMATELY	DRESS	DRESSING AREA	HTG	HEATING	POLY	POLYMER	V	
ARCH	ARCHITECTURAL	DWG	DRAWING	HTR	HEATER	PR	PROJECTION	VB	VINYL BASE
AUX	AUXILIARY			HVAC	HEATING / VENTILATION / AIR CONDITIONING	PVC	POLYVINYL CHLORIDE	VCT	VINYL COMPOSITION TILE
AVG	AVERAGE	E	EACH	I	INTERIOR	Q	QUARRY TILE	VERT	VERTICAL
B	BATHROOM	EA	EACH	ISD	INSIDE DIAMETER	QT	QUARRY TILE	VWC	VINYL WALL COVERING
BO	BOARD	EL	ELEVATION	IN	INCH	R	RETURN AIR	WC	WATER CLOSET OR WALL COVERING
BEGRM	BEDROOM	ELEC	ELECTRIC	INCND	INCANDESCENT	RA	RADIUS	WD	WOOD
BLDG	BUILDING	ELEV	ELEVATOR	INSUL	INSULATION	RAD	RADIUS	WDM	WINDOW
BLKG	BLOCKING	EQ	EQUAL	INT	INTERIOR	RB	RESKENT BASE	W/O	WITHOUT
BLDG	BLOCKING	EQUIP	EQUIPMENT	J	JUNCTION BOX	REF	REFERENCE	WT	WEIGHT
BM	BENCH MARK OR BEAM	EXIST	EXISTING	JB	JUNCTION BOX	REFL	REFLECTED		
BRG	BRICKWORK	EXP	EXPOSED	JST	JOIST	RENF	REINFORCING		
BS	BASE	EXPH	EXPANSION	JT	JOINT	REQD	REQUIRED		
		EXT	EXTERIOR	JT	JOINT	REV	REVERSE		
C	CONDUIT	FCU	FAN COIL UNIT	K	KITCHEN	RM	ROOM		
CAB	CABINET	FD	FLOOR DRAIN	KT	KITCHEN	RO	ROUGH OPENING		
C/C	CENTER TO CENTER	FOF	FOUNDATION	L	LAMINATE	S	SCHEDULE		
CDU	CONDENSING UNIT	FE	FIRE EXTINGUISHER	LAM	LAVATORY	SECT	SECTION		
CFM	CUBIC FEET PER MINUTE	FHO	FIRE HOSE CABINET	LBS	POUNDS	SHT	SHEET		
CG	CORNER GUARD	FIN	FINISH	LF	LINEAR FEET	SIM	SIMILAR		
CL	CENTER LINE	FIX	FIXTURE	LIN	LINEAR	SK	SINK		
CLG	CERILING	FL	FLOOR	M	MAINTENANCE	SPEC	SPECIFICATIONS		
CLO	CLOSET	FP	FIREPROOFING	MAR	MARBLE	SQ	SQUARE		
CLR	CLEAR	FT	FEET	MAT	MATERIAL	SSTL	STAINLESS STEEL		
CM	CENTIMETER	FTG	FOOTING	MAX	MAXIMUM	STD	STANDARD		
CMU	CONCRETE MASONRY UNIT	FUR	FURRED	MECH	MOULDING	STL	STEEL		
COL	COLUMN	G	GAGE	MEC	MOULDING	STR	STRUCTURAL		
CONC	CONCRETE	GA	GAGE	N	NATIONAL ELECTRICAL CODE	SUSP	SUSPENDED		
CONTR	CONTRACTOR	GLV	GALVANIZED	NO	NUMBER	SW	SWITCH		
CONR	CONTRIBUTOR	GL	GLASS	NON	NONMETAL	SYM	SYMMETRICAL		
CPT	CARPET	GLB	GLASS BLOCK	NTC	NOT IN CONTRACT				
CT	CERAMIC	QWB	GYPSUM WALLBOARD	NTS	NOT TO SCALE				
CTR	CENTER	QYP	GYPSUM						
CWP	CILLED WATER PUMP								

DRAWING LIST





DRAWING NO.	DRAWING TITLE
1401	TRAFFIC CONTROL CENTER LOCATION AND KEY PLAN
1402	FINISH SCHEDULE
1403	PLAN OF TRAFFIC CONTROL CENTER
1404	SECTIONS AND DETAILS OF TRAFFIC CONTROL CENTER
1405	POWER SUPPLY ROOM AND GENERATOR ROOM
1406	FIRE FIGHTING FACILITIES
1407	POWER FEEDER FACILITIES
1408	LIGHTING FACILITIES
1409	POWER OUTLET AND TELEPHONE FACILITIES
1410	AIR CONDITIONING AND VENTILATION / OTHERS
1411	AIR CONDITIONING AND VENTILATION FACILITIES

Code	Revision	Date	Initial	BANGKOK AREA TRAFFIC CONTROL SYSTEM PROJECT : STAGE I			
				TRAFFIC CONTROL CENTER LOCATION AND KEY PLAN		Submitted By :	Approved By :
						Jiro Kodera JICA Study Team Leader	Boonyawat Tiptua BMA Study Team Leader
						Designed By :	Checked By :
						Yasuo Nabeshima JICA Study Member	TED, BMA
Associated Plan No. :				JICA	BMA	Scale	Drawing No
				Japan International Cooperation Agency	Bangkok Metropolitan Administration	1 / 1,000	1401
						Date	Total
						SEPTEMBER '90	33 / 43

FLOOR EXISTING	INTERNAL FINISH SCHEDULE			FLOOR										BASE										WALL										CEILING						REMARKS							
	ROOM NAME	CEILING HEIGHT	FINISHING FLOOR LEVEL	ACCESS FLOOR SYSTEM [1]	PVC TILE	CARPET TILE	SAND / CEMENT SCREED TROWELLED	CONCRETE TROWELLED	ASPHALT WATERPROOFING	EXISTING R	EMULSION PAINT	PVC BASE	TIMBER BASE	SAND / CEMENT COVER TROWELLED	EXISTING	FAIR FACED CONCRETE	EMULSION PAINT	PVC WALL COVERING	EXPOSED CONCRETE	FAIR FACED CONCRETE	SAND / CEMENT PLASTER	SINGLE PLASTER BOARD 12mm THICK	DOUBLE PLASTER BOARD 12mm+12mm THICK	EXISTING WALL	DRY TYPE PARTITION WALL SYSTEM 1 [2]	DRY TYPE PARTITION WALL SYSTEM 2 [3]	DRY TYPE PARTITION WALL WITH SOUND ABSORPTION [4]	EMULSION PAINT SPRAYED FINISH	PVC WALL COVERING	ORNAMENTAL GYPSUM PLASTER BOARD	PLASTER BOARD 12mm THICK	ACOUSTIC ROCK WOOL BOARD 12mm THICK	ASBESTOS CEMENT BOARD 6mm THICK	EXPOSED CONCRETE	EXISTING CEILING	SUSPENDED CEILING SYSTEM 1 [5]	SUSPENDED CEILING SYSTEM 2 [6]										
2 ND (TRAFFIC CONTROL CENTER)	CONTROL ROOM	3,000 2,000	500	○																																											
	LIVING ROOM	3,000	500	○																																											
	RECEPTION ROOM	3,000	500	○																																											
	CONTROL DESK	-	900	○																																											
	BROADCASTING ROOM	2,500	1,700	○																																											
	TRAFFIC POLICE OFFICE	3,000	500	○																																											
	ENG. I (HEAD)	3,000	500	○																																											
	ENG. II (ASST.)	3,000	500	○																																											
	COMPUTER ROOM	3,000	500	○																																											
	SOFTWARE STORAGE	3,000	500	○																																											
	MAINTENANCE & STORAGE	3,000	500	○																																											
	1 ST	POWER SUPPLY ROOM	EXIST	EXIST																																											
GENERATOR ROOM		2,800 1,600	100				○	○																																							
FUEL TANK ROOM		3,000	100				○	○																																							
BASEMENT																																															





NOTES

- 1 SCOPE OF WORK
- 1-1 CONTROL CENTER INCLUDING CONTROL ROOM, LIVING ROOM, RECEPTION ROOM, CONTROL DESK, BROADCASTING ROOM, TRAFFIC POLICE OFFICE, ENG I (HEAD), ENG II (ASST), COMPUTER ROOM, SOFTWARE STORAGE, MAINTENANCE & STORAGE AND CONFERENCE ROOM'S MOVABLE FURNITURE.
- 1-2 POWER SUPPLY ROOM
- 1-3 GENERATOR ROOM
- 1-4 WATER SUPPLY, DRAINAGE SYSTEM ARE OUT OF SCOPE.
- 1-5 FOR POWER SUPPLY FROM MAIN STREET TO THE ATC CENTER, THE CONTRACTOR SHOULD BE NEGOTIATED WITH A ELECTRIC POWER SUPPLY COMPANY.

- 2 DRY TYPE PARTITION SYSTEM 1 
- 3 DRY TYPE PARTITION SYSTEM 2 
- 4 DRY TYPE PARTITION WITH SOUND ABSORPTION 
- 5 SUSPENDED CEILING SYSTEM 1 
- 6 SUSPENDED CEILING SYSTEM 2 
- 7 PANELS FOR THE FREE ACCESS FLOOR, SHALL BE OF 600 mm x 600 mm MODULAR.

EXTERNAL FINISH SCHEDULE OF GENERATOR ROOM	
ROOF	SAND / CEMENT SCREED TROWELLED ON 3 LAYER ASPHALT WATERPROOFING MEMBRANE [1403]
COPING	SAND / CEMENT SCREED TROWELLED
SCUPPER	STAINLESS STEEL SCUPPER FLASHING [1403]
WALL	ACRYLIC RESIN EMULSION SPRAYED ON FAIR FACED CONCRETE SAND / CEMENT SCREED TROWELLED 300 HEIGHT
FRONT TERRACE	SAND / CEMENT SCREED TROWELLED
WINDOWS	JALOUSIE WINDOW FULL SURROUND ALUM. FRAME WITH DUAL CRANK OPERATOR
LOUVERS	FIX ALUM. LOUVER FULL SURROUND ALUM. FRAME
DOORS	DOUBLE SWINGING STEEL FLUSH DOORS

- SYMBOLS**
- [1] REFERENCE NO. OF NOTES
 - [1403] DWG. SHEET NUMBER
 - SURFACE FINISH MATERIALS OR SYSTEM MATERIALS
 - ⊙ BED MATERIAL
 - ⊙ DOOR NUMBER
 - ⊙ FURNITURE NUMBER
 - ⊙ EQUIPMENT NUMBER

BANGKOK AREA TRAFFIC CONTROL SYSTEM PROJECT : STAGE I				Submitted By :	Approved By :
				 Juro Kudara JICA Study Team Leader	 Boonyawat Tiptus BMA Study Team Leader
FINISH SCHEDULE				Designed By :	Checked By :
				 Yasuo Nabeshima JICA Study Member	 YED, BMA
Code	Revision	Date	Initial	JICA	BMA
Associated Plan No. :				Japan International Cooperation Agency	Bangkok Metropolitan Administration
				Scale	Drawing No. 1402
				Date SEPTEMBER '00	Total 34/43

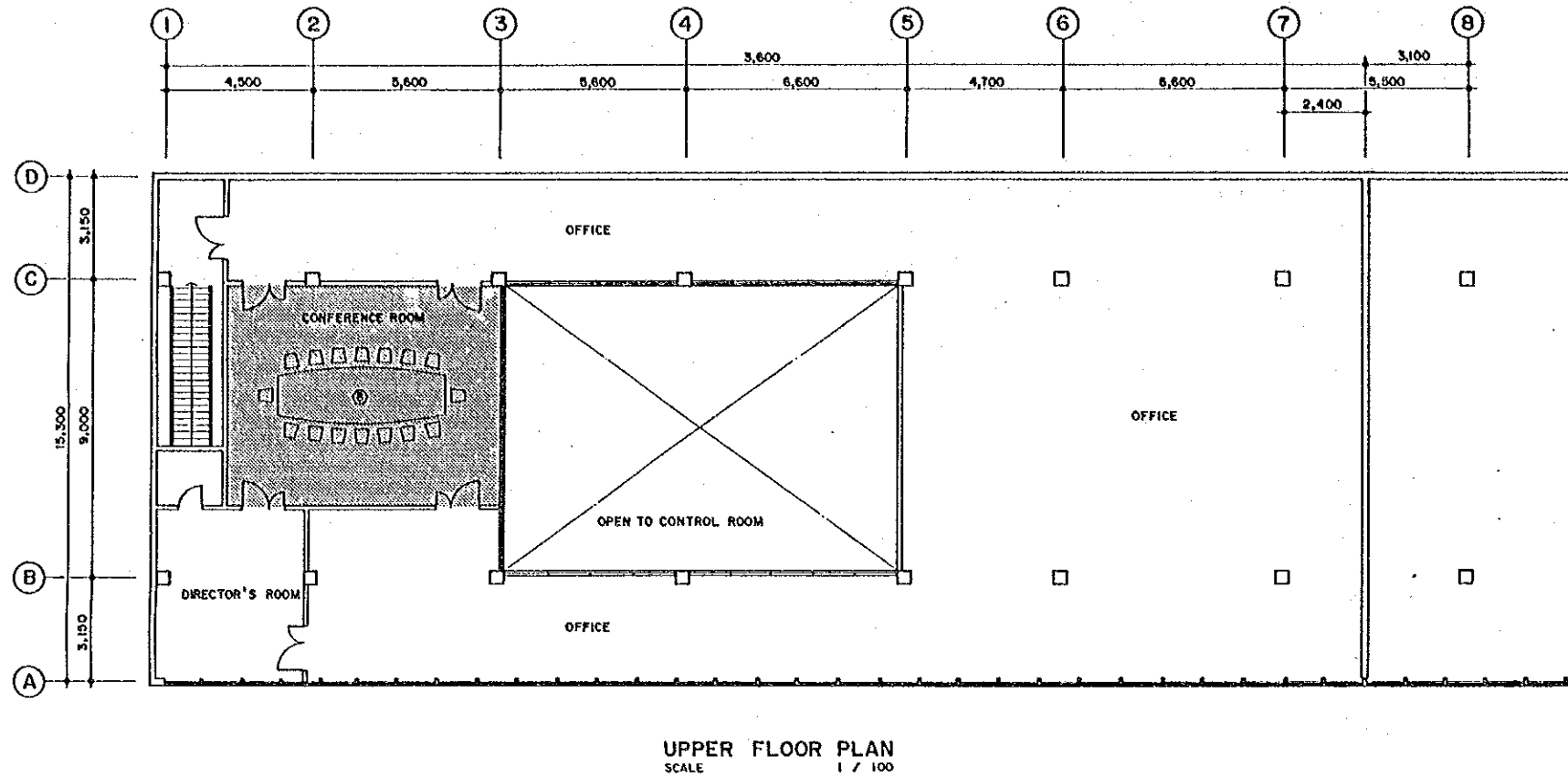

LEGEND

- SCOPE OF WORK
- ONLY MOVABLE FURNITURE SCOPE OF WORK
- OUT OF SCOPE
- DRY TYPE PARTITION WALL SYSTEM 1 [1402] OR SINGLE PLASTER BOARD 12mm. THICK
- DRY TYPE PARTITION WALL SYSTEM 2 [1402] OR DOUBLE PLASTER BOARDS 12mm. + 12mm. THICK
- DRY TYPE PARTITION WALL WITH SOUND ABSORPTION
- EXIST. WALL

DOORS AND WINDOWS SCHEDULE

- | | | |
|---|---|---------------------------|
| ① | SINGLE SWINGING WOOD DOOR | W 800 mm. x H 2,000 mm. |
| ② | DOUBLE SWINGING WOOD DOORS | W 1,200 mm. x H 2,000 mm. |
| ③ | DOUBLE SWINGING WOOD DOORS | W 1,800 mm. x H 2,000 mm. |
| ④ | DOUBLE SWINGING WOOD DOORS (FREEDOM HINGES) | W 1,800 mm. x H 2,000 mm. |
| ⑤ | FIX ALUMINUM WINDOW | W 800 mm. x H 800 mm. |
| ⑦ | HORIZONTAL SLIDING ALUMINUM WINDOW | W 1,000 mm. x H 400 mm. |
| ⑧ | FIX ALUMINUM WINDOW | W 1,200 mm. x H 2,000 mm. |
| ⑨ | FIX ALUMINUM WINDOW | [1404] |

MOVABLE FURNITURE SCHEDULE

- ① SOFA WITH STOOL
- ② SOFA
- ③ ARMCHAIR
- ④ CHAIR
- ⑤ DESK
- ⑥ TABLE WITH CHAIRS
- ⑦ LONG TABLE
- ⑧ MEETING TABLE WITH CHAIRS

EQUIPMENT SCHEDULE

- ① KITCHEN UNIT
- ② REFRIGERATOR
- ③ TV & VIDEO TAPE RECORDER WITH CABINET
- ④ VENTILATOR WITH FRESH AIR INTAKE DUCT

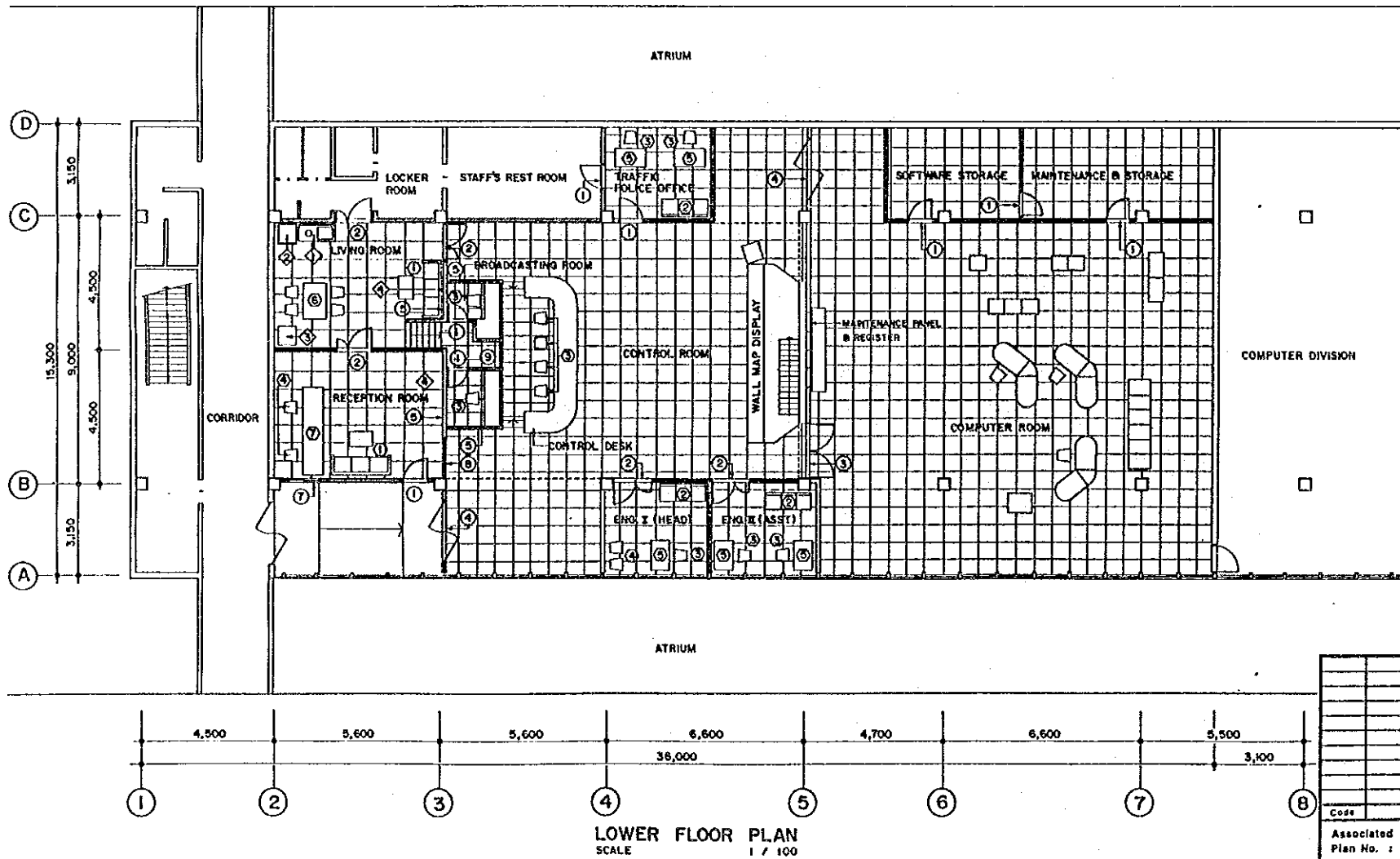

BANGKOK AREA TRAFFIC CONTROL SYSTEM PROJECT : STAGE I			
PLAN OF TRAFFIC CONTROL CENTER		Submitted By : Juro Kodera JICA Study Team Leader	Approved By : Boonyarat Tiplua BMA Study Team Leader
		Designed By : Yasuo Hasekuma JICA Study Member	Checked By : TED.BMA
Code	Revision	Date	Initial
Associated Plan No. :		JICA Japan International Cooperation Agency	BMA Bangkok Metropolitan Administration
		Scale 1 / 100	Drawing No 1403
		Date SEPTEMBER '90	Total 35 / 43

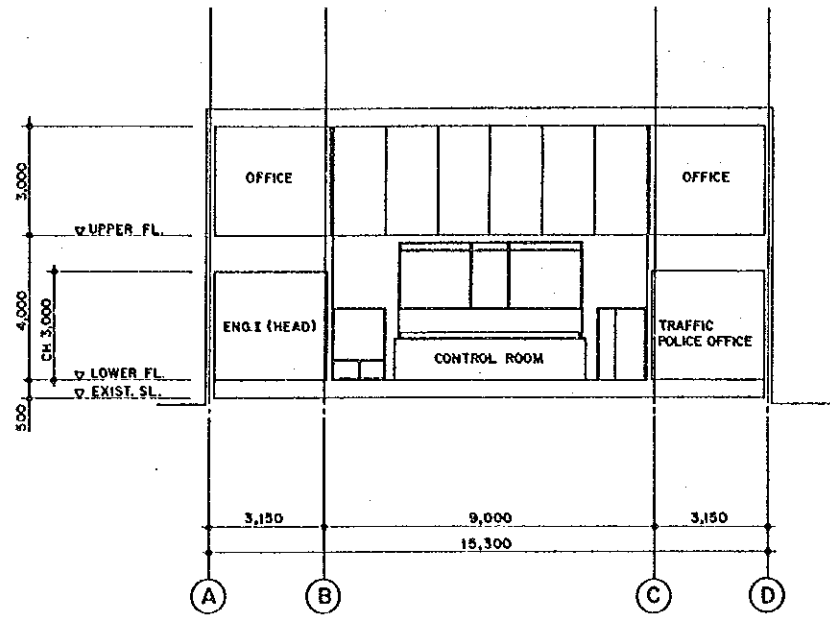

CROSS SECTION
SCALE 1/100

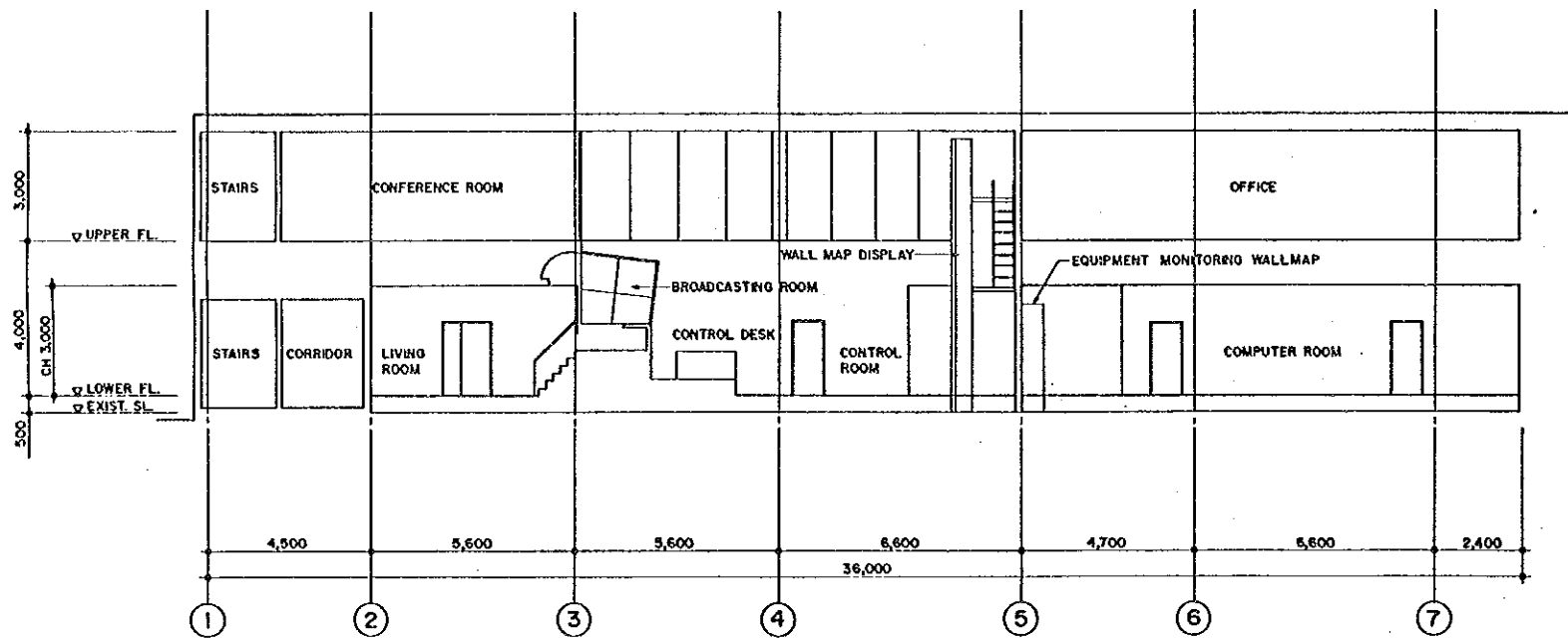

LONGITUDINAL SECTION
SCALE 1/100

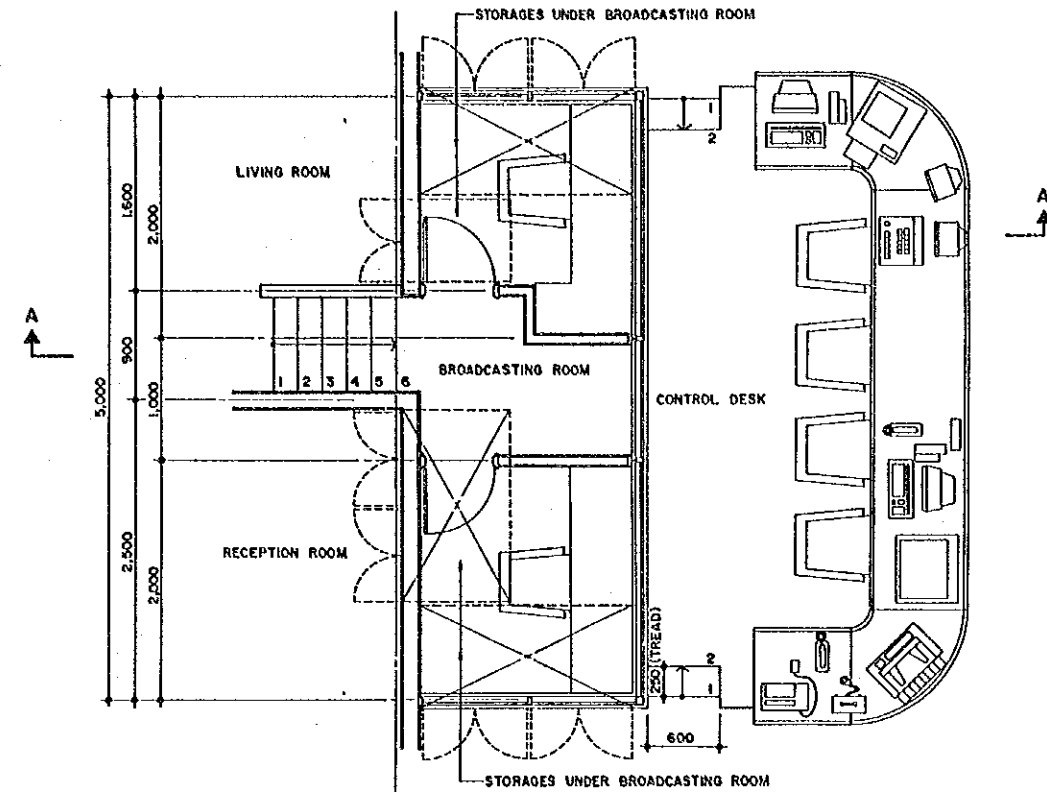

DETAIL PLAN OF
BROADCASTING RM. & CONTROL DESK
SCALE 1/30

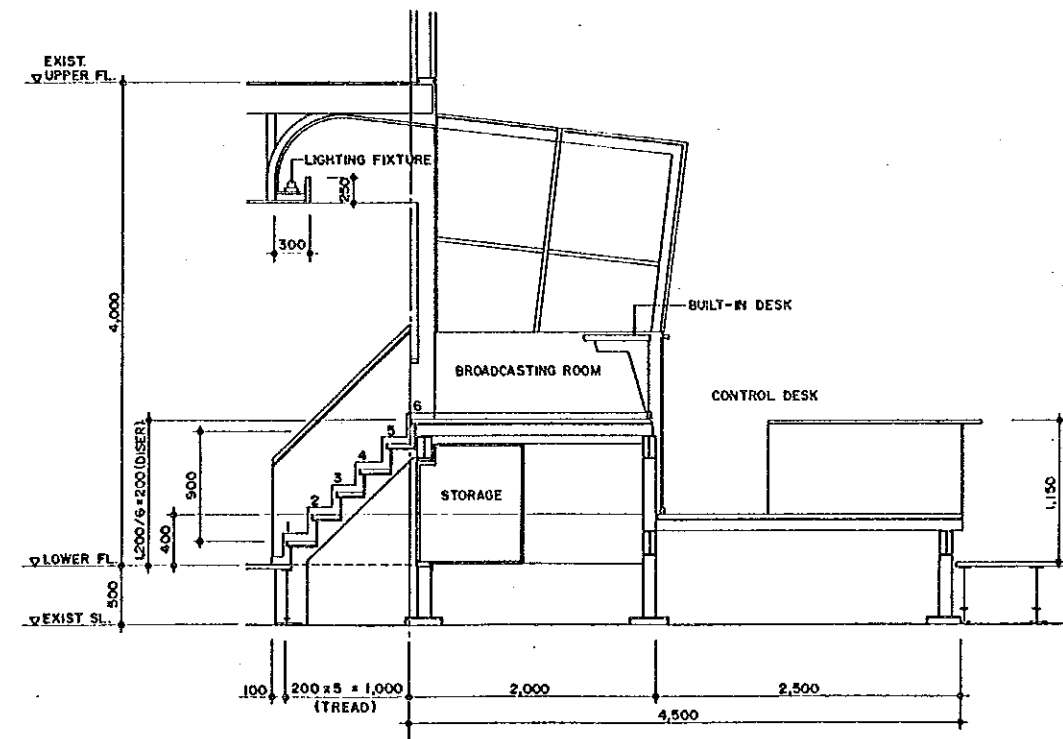

A-A DETAIL SECTION
SCALE 1/30

BANGKOK AREA TRAFFIC CONTROL SYSTEM PROJECT : STAGE I			
SECTIONS AND DETAILS OF TRAFFIC CONTROL CENTER		Submitted By : Jure Kodera JICA Study Team Leader	Approved By : Boonyawat Tiptua BMA Study Team Leader
		Designed By : Yasuo Nakashima JICA Study Member	Checked By : TED, BMA
Code	Revision	Date	Initial
Associated Plan No. :	JICA Japan International Cooperation Agency	BMA Bangkok Metropolitan Administration	Scale 1/30, 1/100 Date SEPTEMBER '90
		Drawing No. 1404	Total 36/43

GENERATOR ROOM

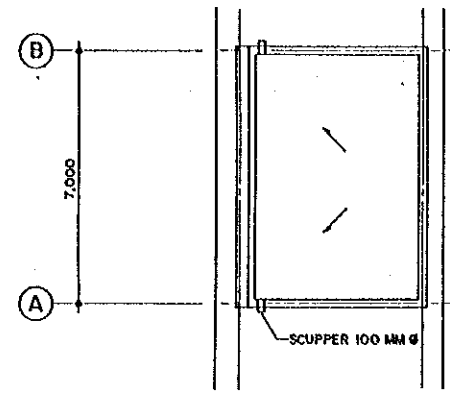

ROOF PLAN
SCALE 1/100

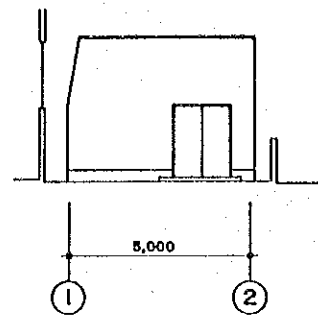

NORTH ELEV.
SCALE 1/100

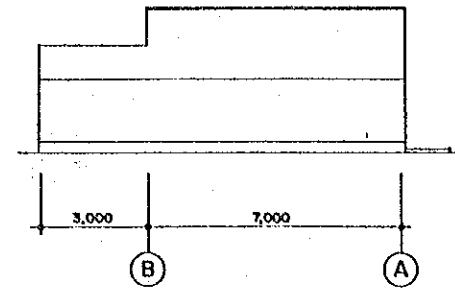

EAST ELEV.
SCALE 1/100

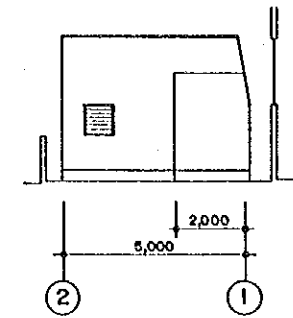

SOUTH ELEV.
SCALE 1/100

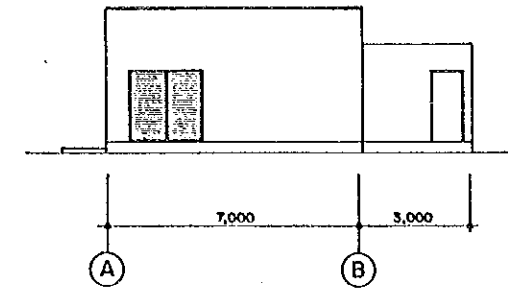

WEST ELEV.
SCALE 1/100

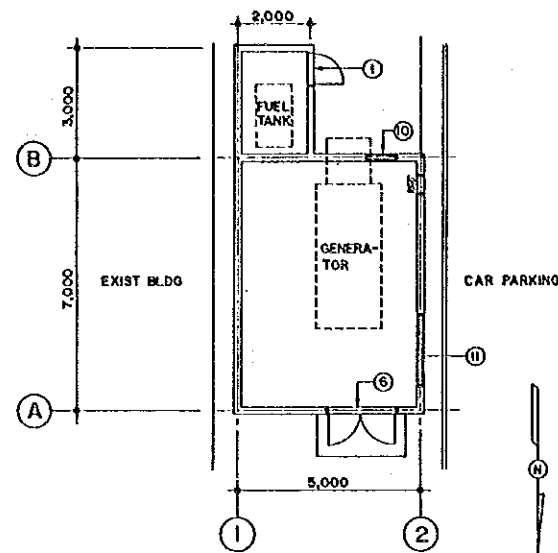

P L A N
SCALE 1/100

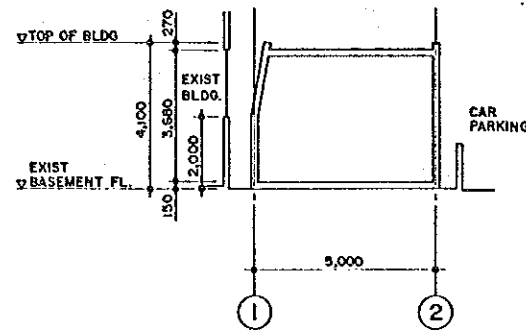

CROSS SECTION
SCALE 1/100

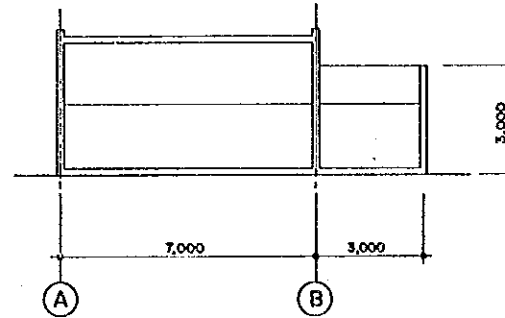

LONGITUDINAL SECTION
SCALE 1/100

DOORS AND WINDOWS SCHEDULE

- ① SINGLE SWINGING WOOD DOOR W 800 mm x H 2,000 mm
- ⑥ DOUBLE SWINGING STEEL DOOR W 1,800 mm x H 2,000 mm
- ⑩ JALOUSIE WINDOW W 800 mm x H 800 mm
- ⑫ ALUMINUM LOUVERS W 2,000 mm x H 2,000 mm

POWER SUPPLY ROOM

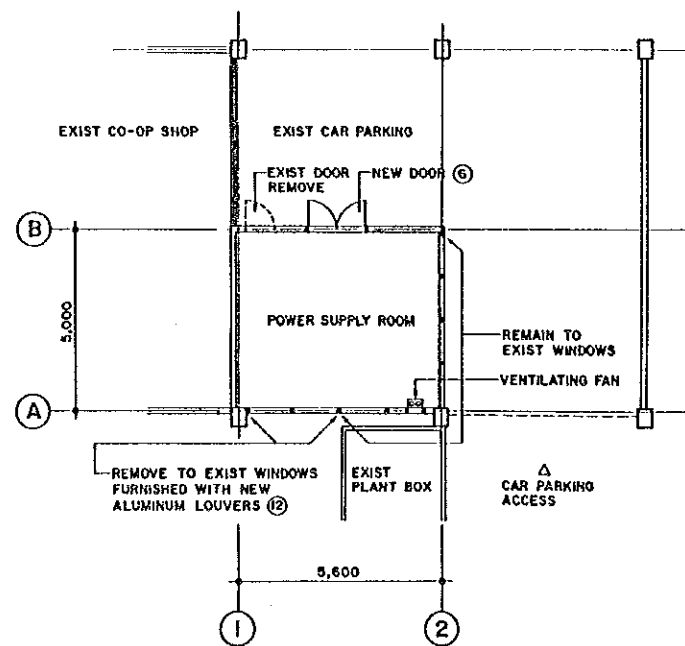

P L A N
SCALE 1/100

DOORS AND WINDOWS SCHEDULE

- ⑥ DOUBLE SWINGING STEEL DOOR W 800 mm x H 2,000 mm
- ⑫ ALUMINUM LOUVERS W 1,800 mm x H 1,200 mm

NOTES

REMOVE AND REPAIR, REPAINT TO EXIST DOOR

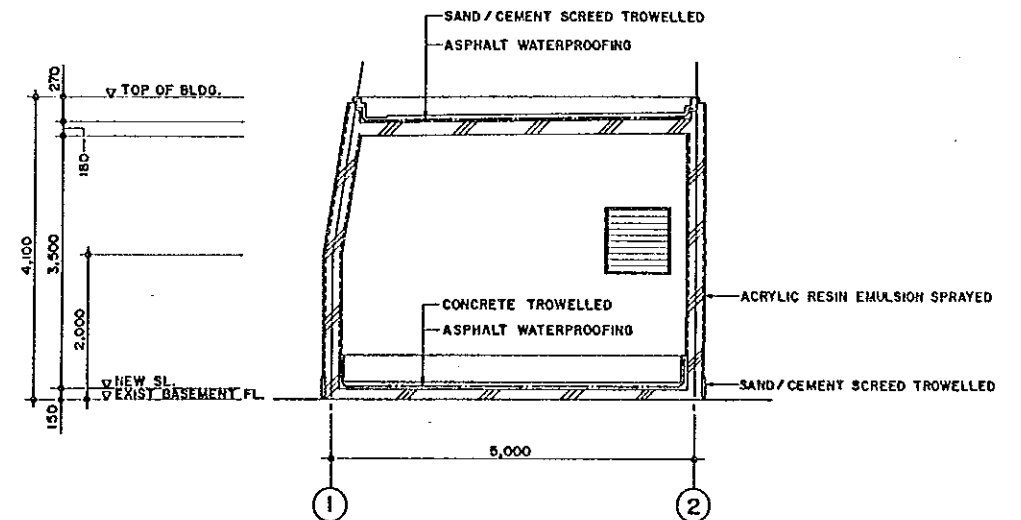

DETAIL CROSS SECTION
SCALE 1/50

BANGKOK AREA TRAFFIC CONTROL SYSTEM PROJECT : STAGE I

**POWER SUPPLY ROOM
AND
GENERATOR ROOM**

Submitted By : Juno Kodera
JICA Study Team Leader
Approved By : Boonyawat Tiptua
BMA Study Team Leader
Designed By : Yasuo Nabeshima
JICA Study Member
Checked By : TED, BMA

Code	Revision	Date	Initial

JICA Japan International
Cooperation Agency

BMA Bangkok Metropolitan
Administration

Scale 1/50, 1/100
Date 'SEPTEMBER' 90

Drawing No 1405
Total 37/43

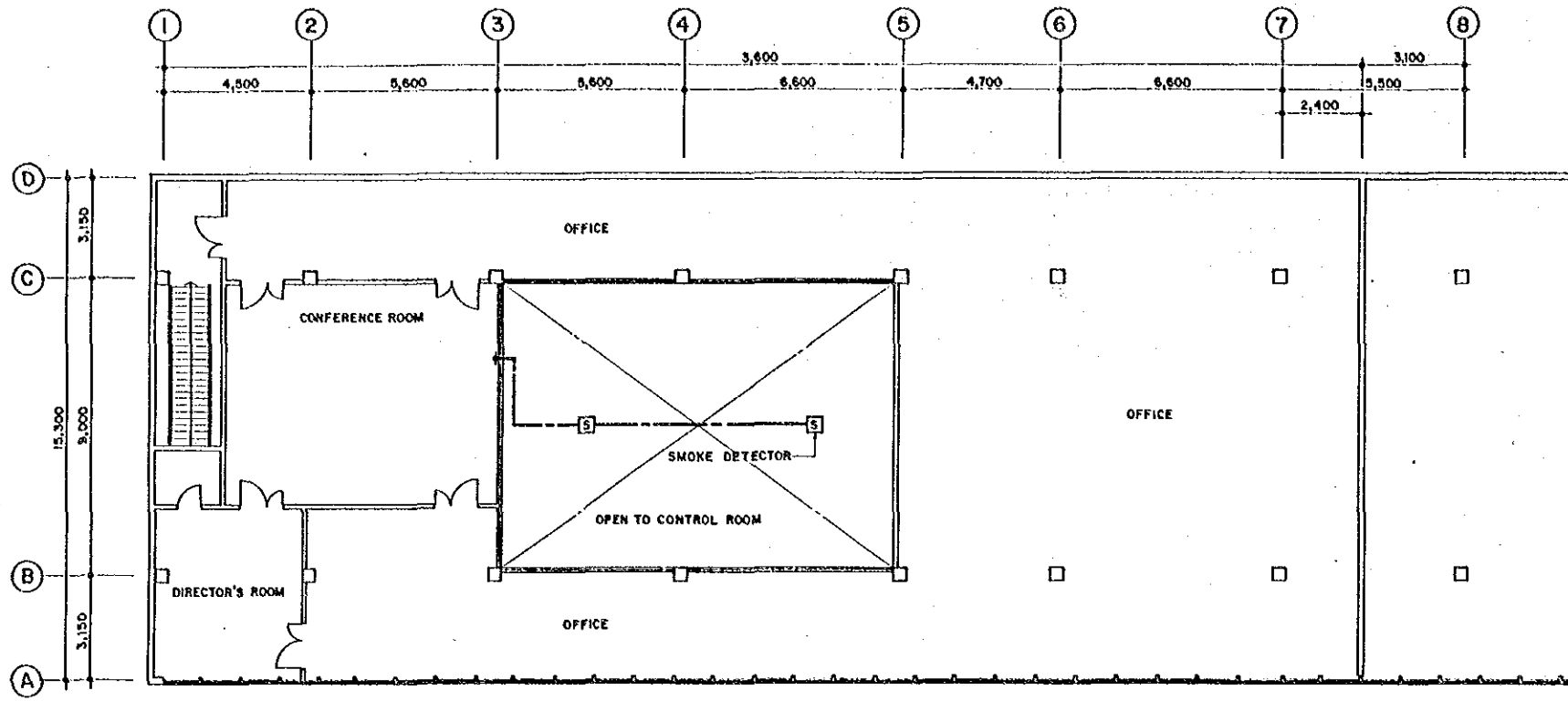

UPPER FLOOR PLAN
SCALE 1 / 100

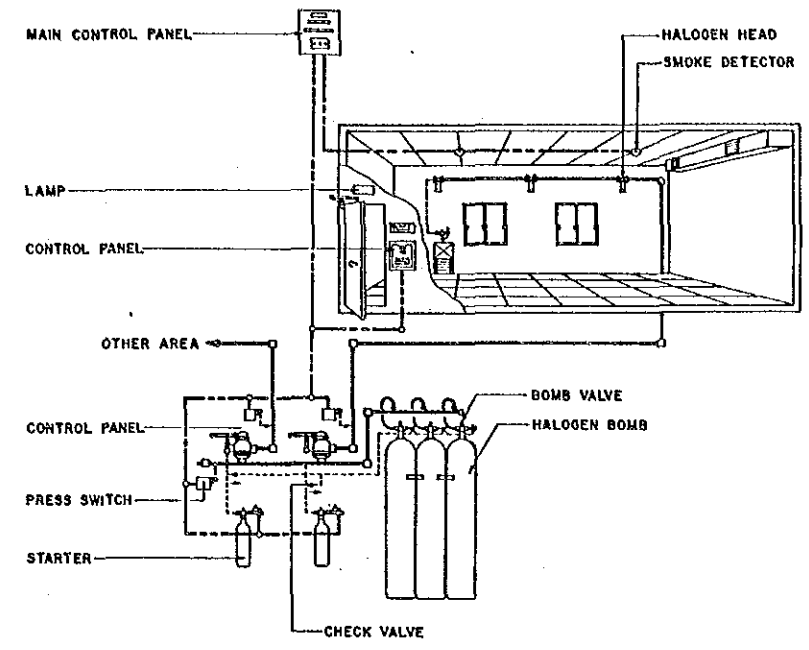

HALOGEN FIRE FIGHTING SYSTEM
OUT LINE FLOW DIAGRAM

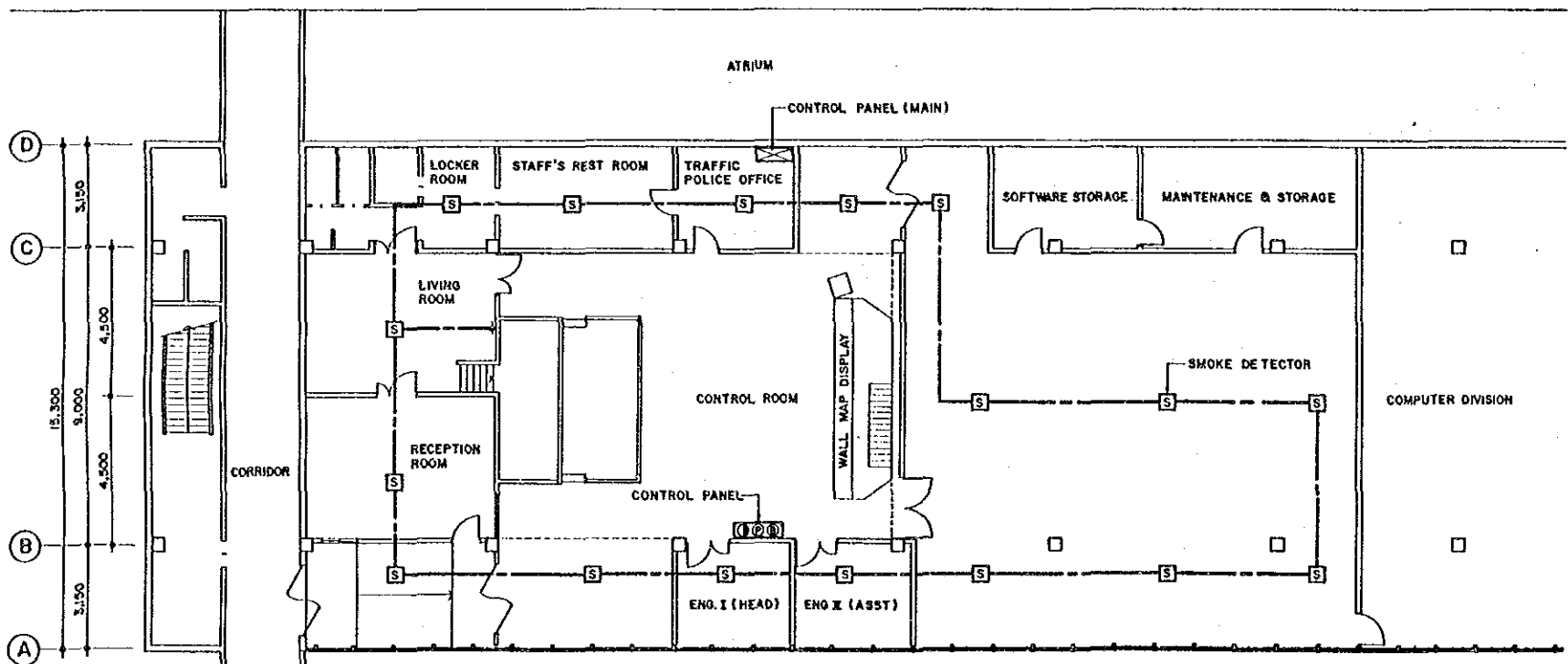

LOWER FLOOR PLAN
SCALE 1 / 100

BANGKOK AREA TRAFFIC CONTROL SYSTEM PROJECT : STAGE I			
FIRE FIGHTING FACILITIES		Submitted By : Jura Kodera JICA Study Team Leader	Approved By : Beeayawal Tiptua BMA Study Team Leader
		Designed By : Yasuo Kobayashi JICA Study Member	Checked By : TED, BMA
Associated Plan No. :		Scale 1 / 100	Drawing No 1406
Code		Date	Total 38 / 43
Revision		Date	
Initial		Date	
JICA Japan International Cooperation Agency		BMA Bangkok Metropolitan Administration	Date SEPTEMBER '90

NOTE

1. ELECTRIC CAPACITIES MENTIONED IN THIS DWG. IS ONLY REFERENCE.
2. ELECTRIC CAPACITIES FOR EACH EQUIPMENT SHALL BE DECIDED BY THE SUCCESSFUL CONTRACTOR.

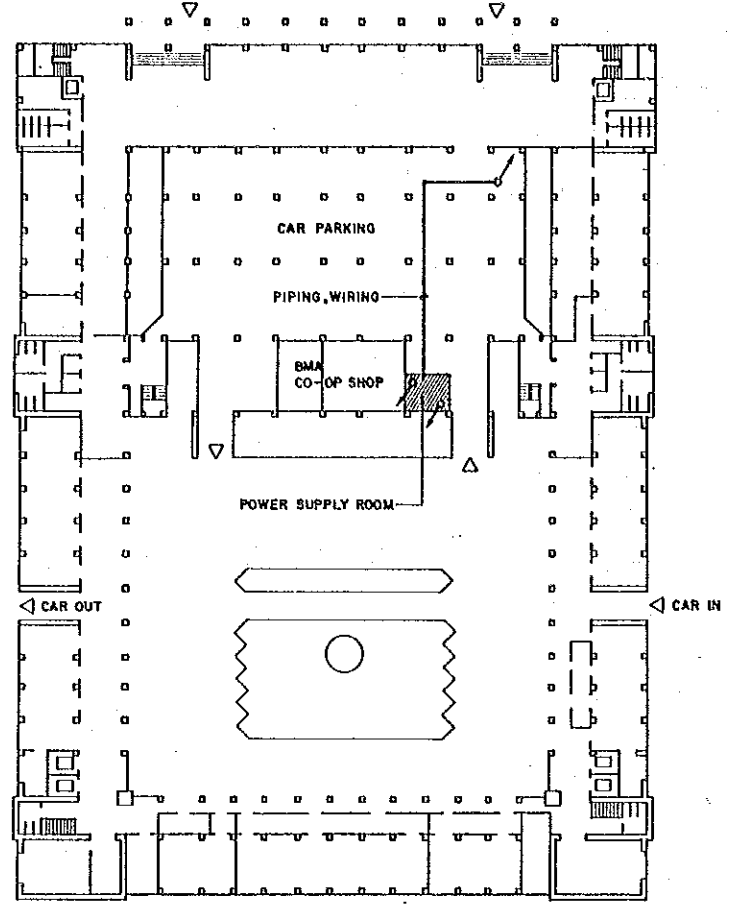

1ST FLOOR
SCALE 1 / 500

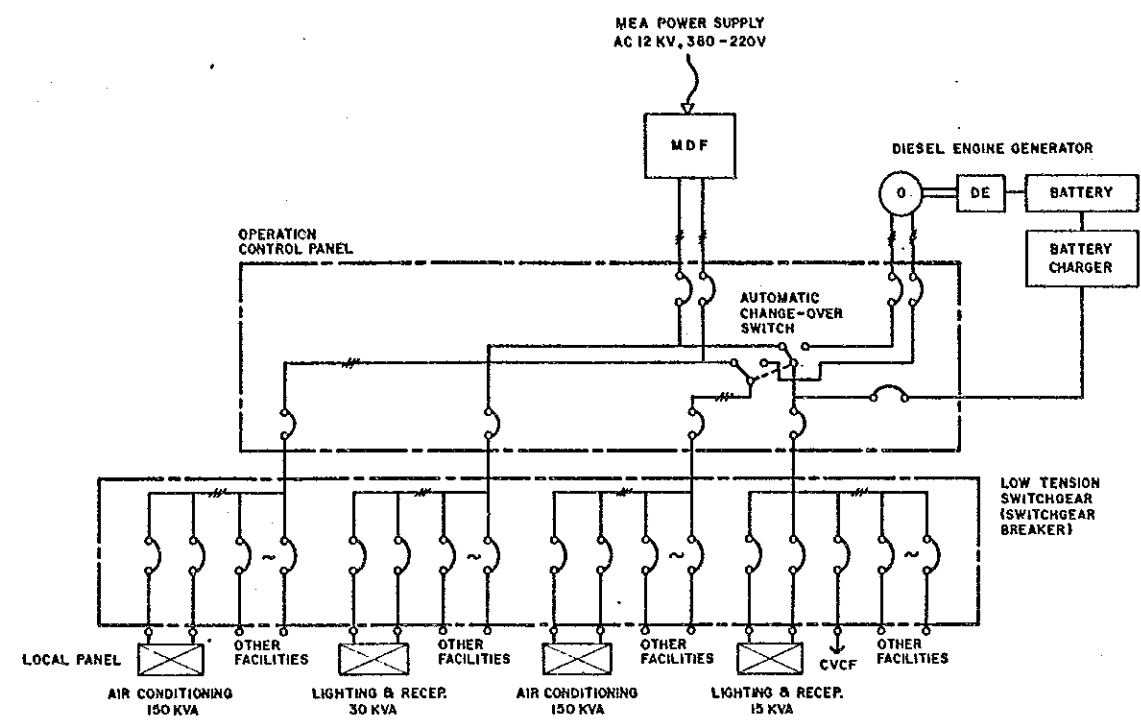

POWER SUPPLY DIAGRAM

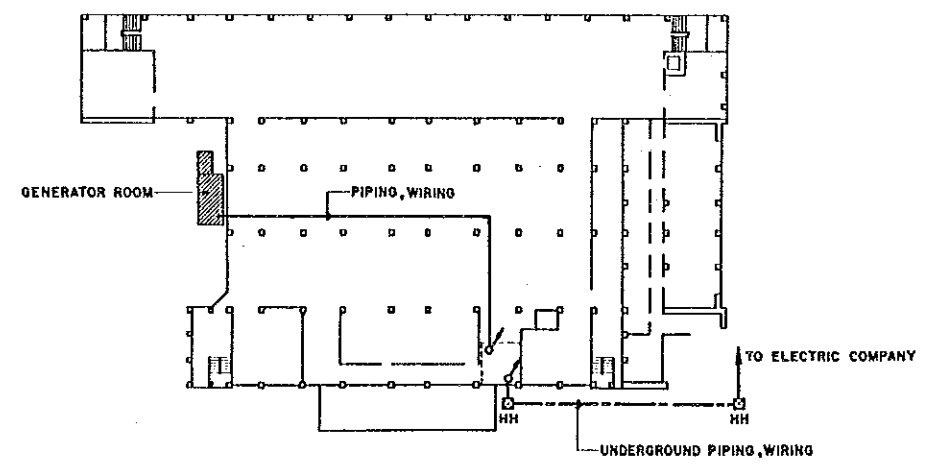

BASEMENT FLOOR
SCALE 1 / 500

BANGKOK AREA TRAFFIC CONTROL SYSTEM PROJECT : STAGE I			
POWER FEEDER FACILITIES		Submitted By :	Approved By :
		Jiro Kodera JICA Study Team Leader	Boonyawat Tiptua BMA Study Team Leader
		Designed By :	Checked By :
		Yasuo Nobeshima JICA Study Member	TEO, BMA
Code	Revision	Date	Initial
Associated Plan No. :	JICA Japan International Cooperation Agency	BMA Bangkok Metropolitan Administration	Scale 1 / 500 Drawing No 1407 Date SEPTEMBER '90, Total 39 / 43

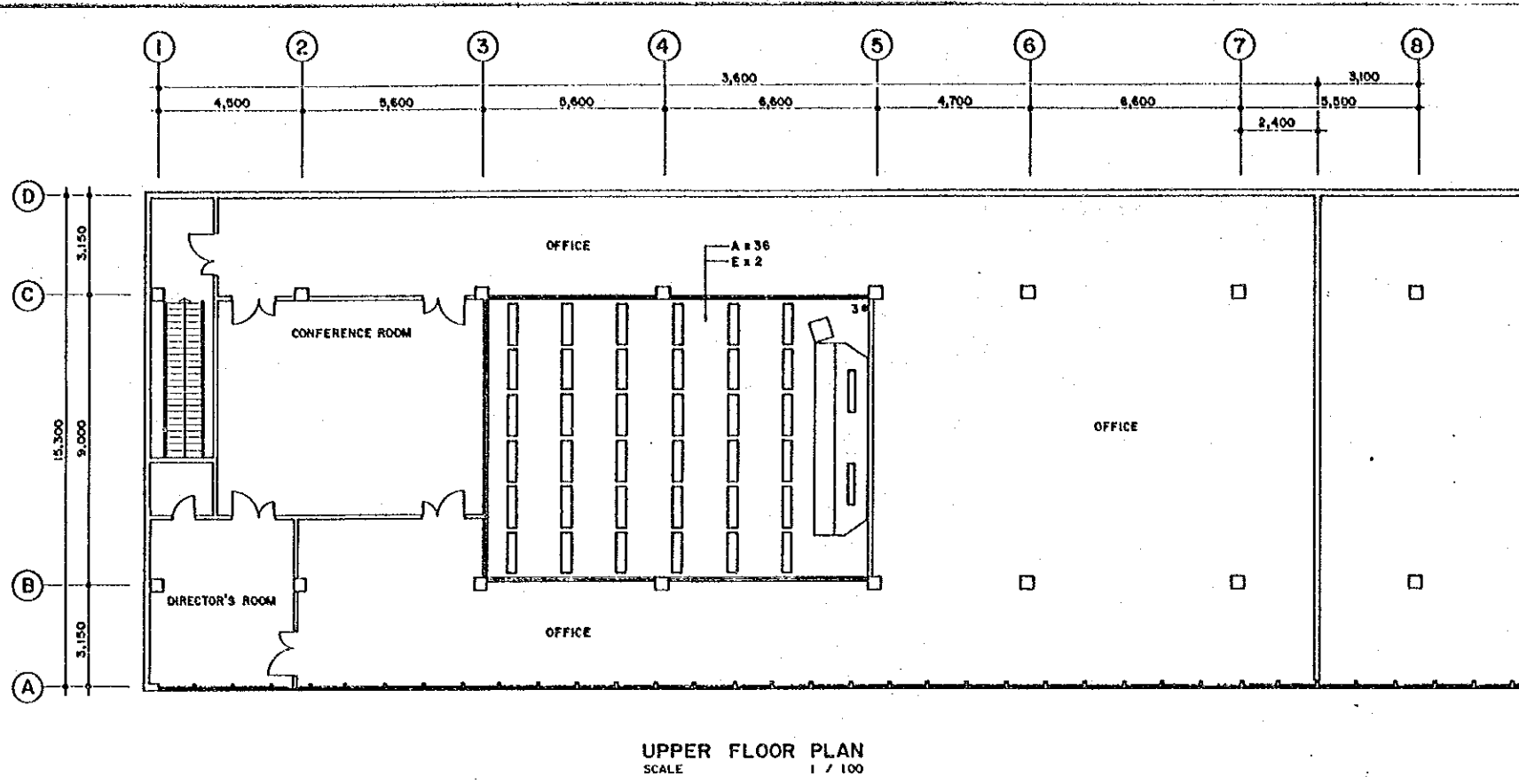

LIGHTING FIXTURE SCHEDULE

A	FL 40 ^W -2	B	FL 40 ^W -3	C	FL 40 ^W -2	D	FL 40 ^W -2
 NOMINAL & EMERGENCY LIGHTS IN BOTH DIRECTION		 COMPUTER ROOM, CONTROL ROOM BROADCASTING ROOM		 TRAFFIC POLICE OFFICE ENO. I ENO. II		 SOFTWARE STORAGE MAINTENANCE & STORAGE	
E	FL 40 ^W -1	F	IL 40 ^W	G	IL 60 ^W	H	FL 10 ^W -1
 WALL MAP DISPLAY STAFF'S REST ROOM		 LAVATORY		 SHOWER ROOM		 STAFF'S REST ROOM	
I	FL 10 ^W -1	J	FL 40 ^W -1				
 EXIT SIGN ENCLOSED BATTERY		 COMPUTER ROOM, CONTROL ROOM RECEPTION ROOM		SUBSTATION ROOM GENERATOR ROOM			

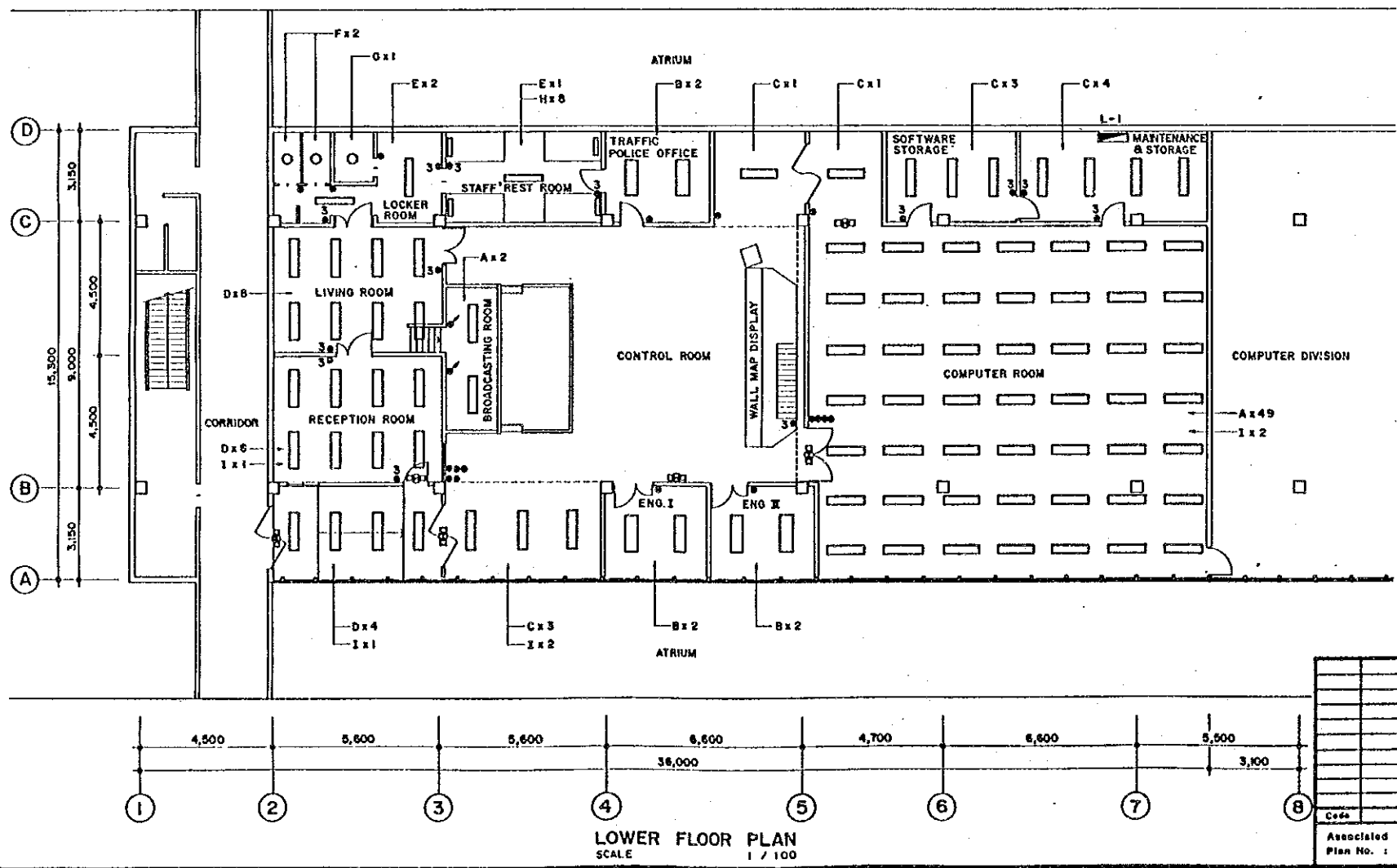

SYMBOL

- DISTRIBUTION BOARD
- SINGLE POLE SWITCH
- 3 WAY SWITCH
- LIGHTING CONTROL SWITCH

				BANGKOK AREA TRAFFIC CONTROL SYSTEM PROJECT : STAGE I			
				LIGHTING FACILITIES		Submitted By :	Approved By :
						Jiro Kodera JICA Study Team Leader	Boonyarat Tiptus BMA Study Team Leader
						Designed By :	Checked By :
						Yasuo Nabeshima JICA Study Member	TED, BMA
Code	Revision	Date	Initial	JICA	BMA	Scale	Drawing No
Associated Plan No. :				Japan International Cooperation Agency	Bangkok Metropolitan Administration	1 / 100	1408
				Date	SEPTEMBER '90	Total	40 / 43

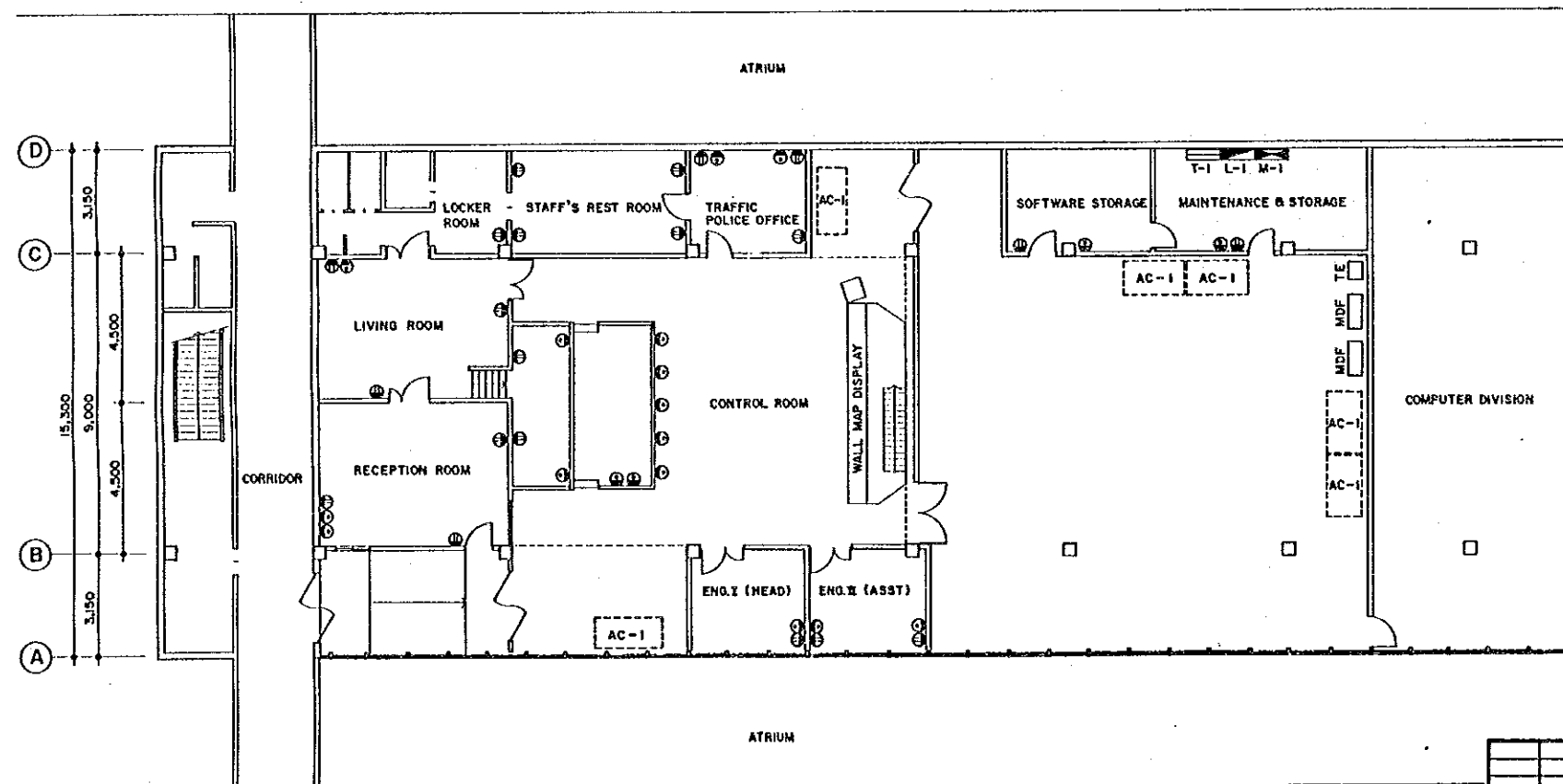
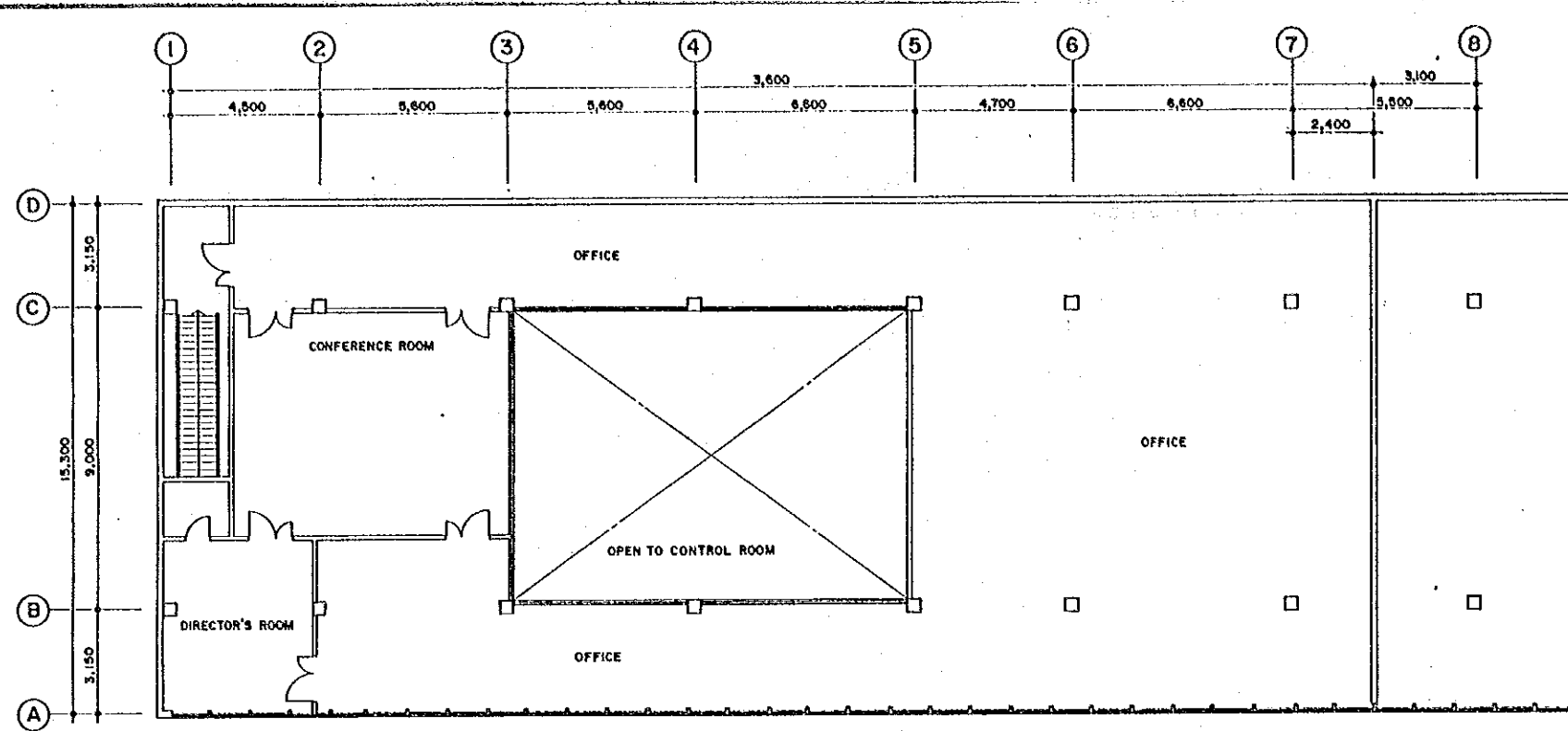

- SYMBOL**
- M-I MOTOR CONTROL BOARD
 - L-I DISTRIBUTION BOARD
 - T-I TERMINAL
 - MDF MAIN DISTRIBUTION FRAME
 - TE TELEPHONE EXCHANGE
 - DUPLEX RECEPTACLE OUTLET
 - WALL TELEPHONE OUTLET

BANGKOK AREA TRAFFIC CONTROL SYSTEM PROJECT: STAGE I			
POWER, OUTLET & TELEPHONE FACILITIES		Submitted By : Jure Kadea JICA Study Team Leader	Approved By : Boonyawat Tiptus BMA Study Team Leader
		Designed By : Yasuo Hoshizumi JICA Study Member	Checked By : TED, BMA
Associated Plan No. :		JICA Japan International Cooperation Agency	BMA Bangkok Metropolitan Administration
Code		Revision	Date
Date		Scale 1 / 100	
Drawing No. 1409		Total 41 / 43	

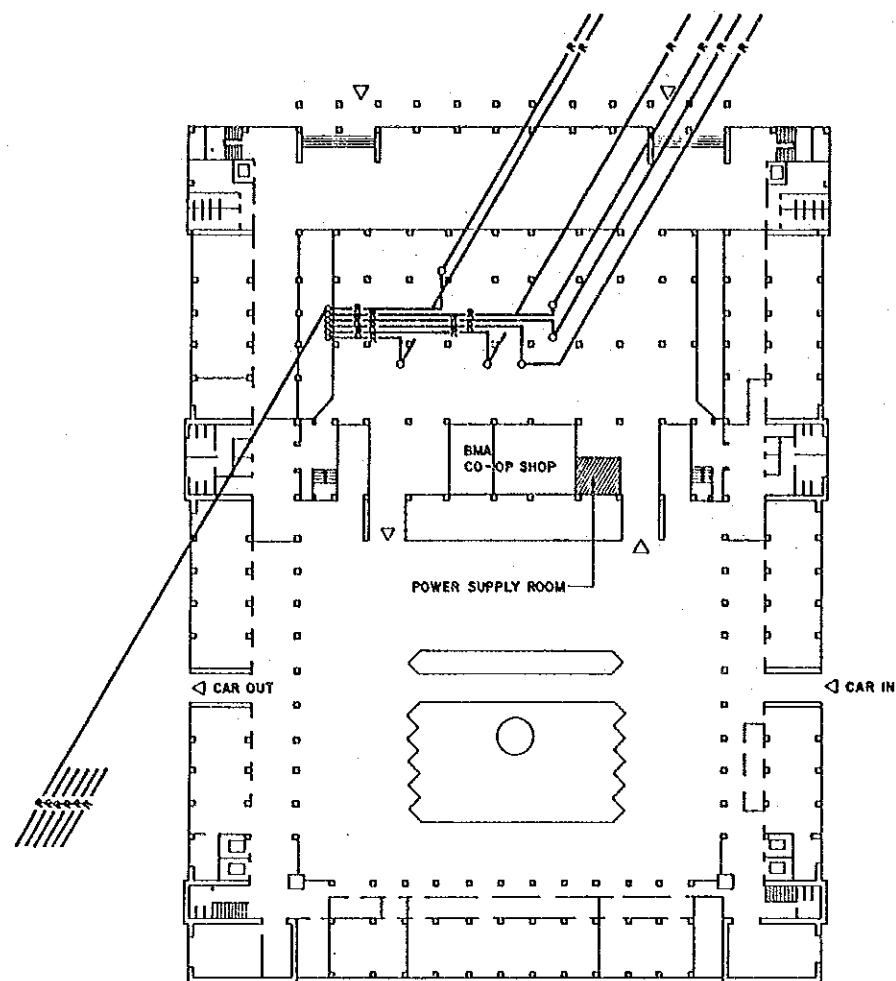

1ST FLOOR
SCALE 1 / 500

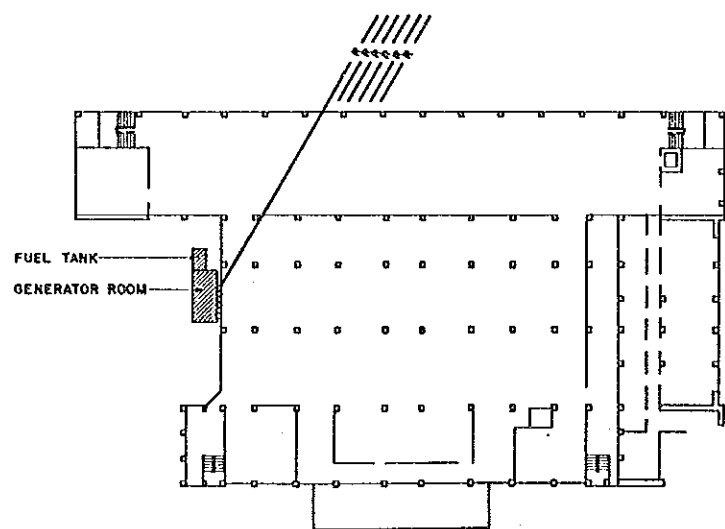

BASEMENT FLOOR
SCALE 1 / 500

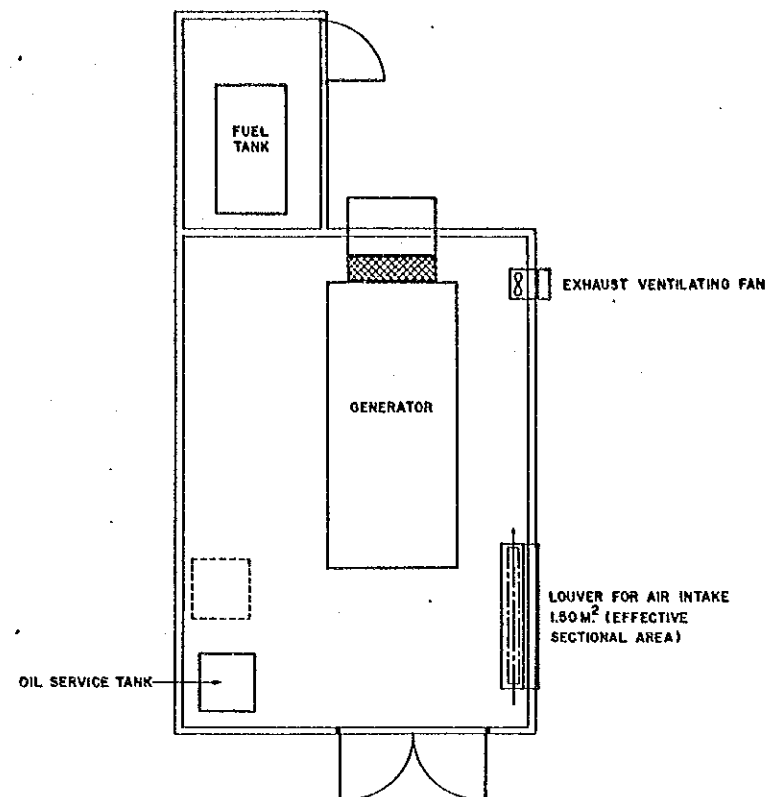

GENERATOR ROOM
SCALE 1 / 50

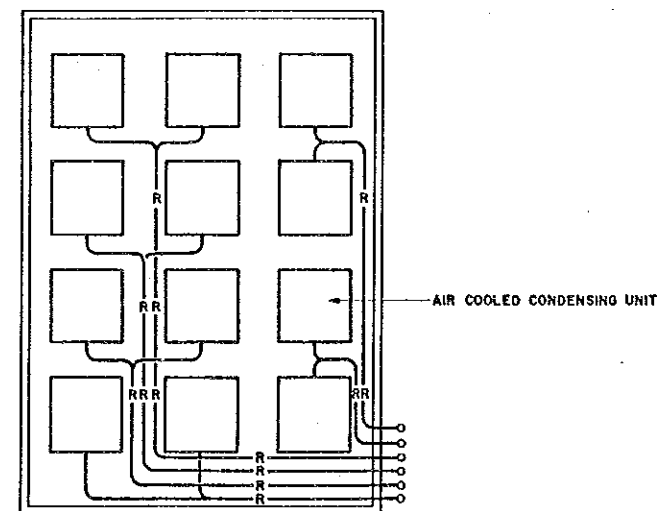

ROOF
SCALE 1 / 50

				BANGKOK AREA TRAFFIC CONTROL SYSTEM PROJECT: STAGE I			
				AIR CONDITIONING AND VENTILATION / OTHERS		Submitted By :	Approved By :
						Juro Kodera JICA Study Team Leader	Boonyarat Tiplue BMA Study Team Leader
				JICA Japan International Cooperation Agency		Designed By :	Checked By :
						Yasuo Hasehima JICA Study Member	YED, BMA
Code	Revision	Date	Initial	Scale 1 / 50, 1 / 500	Drawing No	1410	
Associated Plan No. :					Date	SEPTEMBER '90	Total
							42 / 43

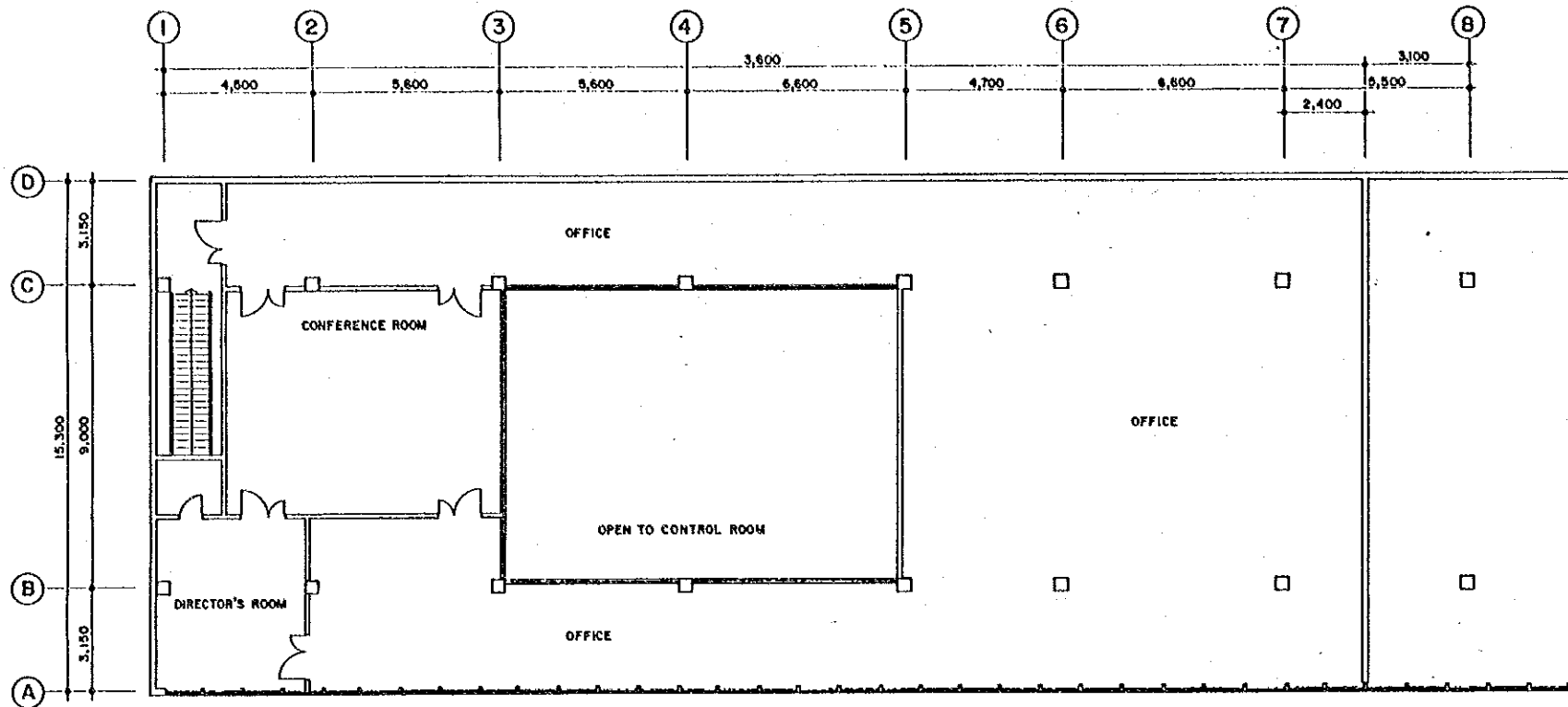

UPPER FLOOR PLAN
SCALE 1 / 100

SYMBOL

- ☐ WEATHER HOOD
- # FIRE DAMPER
- # CD CHECK DAMPER
- OA-G OA GRILLE
- FVD FIRE & VOLUME DAMPER

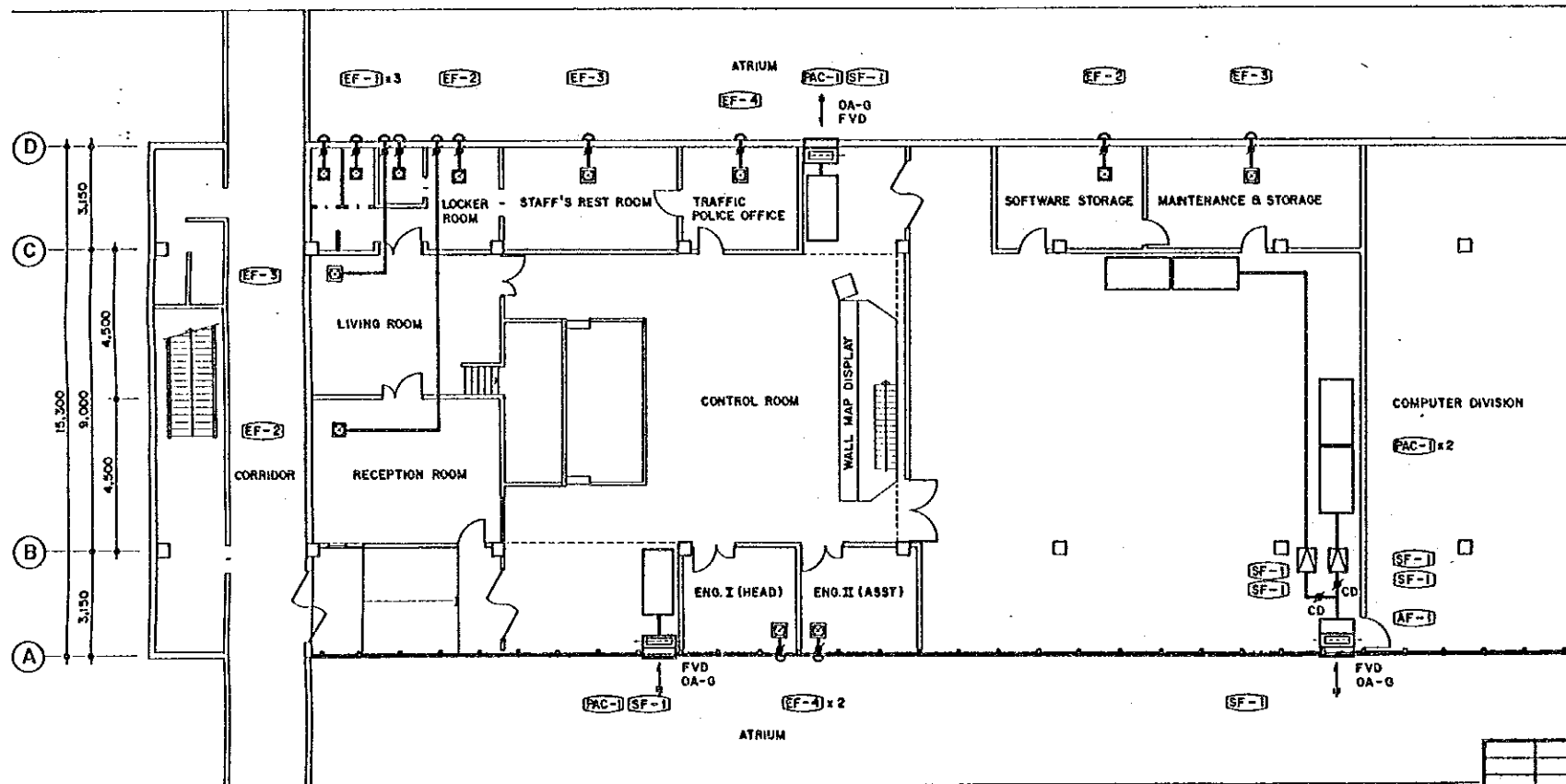

LOWER FLOOR PLAN
SCALE 1 / 100

- PAC-1 PACKAGED AIR CONDITIONER FOR COMPUTER ROOM (AIR COOLED TYPE)
COOLING CAPACITY : 42500 K CAL/H
COMPRESSOR : 7.5 KW x 2 FAN 290 CMH x 6MM A₂ x 7.5 KW 3 Ph - 380 V - 50 HZ
PREFILTER MAINFILTER DUST COLLECTION FACTORY : OVER 85% (NBS) 6 SETS
- SF-1 AIR INTAKE FAN
250 Ø x 150 CMH x 10 MM A₂ x 0.04 KW 1 Ph - 220 V - 50 HZ 6 SETS
- AF-1 AIR FILTER
PREFILTER MAINFILTER DUST COLLECTION FACTORY : OVER 85% (NBS) 1 SET
- VENTILATING FAN
- EF-1 60 CMH x 3 MM A₂ 3 SETS
- EF-2 100 CMH x 3 MM A₂ 3 SETS
- EF-3 150 CMH x 5 MM A₂ 3 SETS
- EF-4 60 CMH x 3 MM A₂ 3 SETS

BANGKOK AREA TRAFFIC CONTROL SYSTEM PROJECT : STAGE I			
AIR CONDITIONING AND VENTILATION FACILITIES		Submitted By : Juro Kodera JICA Study Team Leader	Approved By : Boonswat Tiplua BMA Study Team Leader
		Designed By : Yasuo Nabeshima JICA Study Member	Checked By : TED, BMA
JICA Japan International Cooperation Agency	BMA Bangkok Metropolitan Administration	Scale 1 / 100 Date SEPTEMBER '90	Drawing No 1411 Total 43 / 43
Code	Revision	Date	Initial
Associated Plan No. :			

