

THE REPUBLIC OF INDONESIA

**THE STUDY ON THE MASTER PLAN
OF
AIRPORT MAINTENANCE AND REHABILITATION
IN
THE REPUBLIC OF INDONESIA**

**FINAL REPORT
VOL. 4
DRAWINGS**

MARCH 1991

JAPAN INTERNATIONAL COOPERATION AGENCY

SSF

91-018(4)

108/95.7/SSP

JICA LIBRARY



1090162(7)

22287

THE REPUBLIC OF INDONESIA

**THE STUDY ON THE MASTER PLAN
OF
AIRPORT MAINTENANCE AND REHABILITATION
IN
THE REPUBLIC OF INDONESIA**

FINAL REPORT

**VOL. 4
DRAWINGS**

MARCH 1991

JAPAN INTERNATIONAL COOPERATION AGENCY



国際協力事業団

22287

LIST OF DRAWING

<u>NAME OF AIRPORT</u>	<u>DWG NO.</u>	<u>NAME OF DRAWING</u>	<u>NAME OF AIRPORT</u>	<u>DWG NO.</u>	<u>NAME OF DRAWING</u>
1. Gunung Sitoli	GNS-1	Layout Plan	6. Ambon	AMQ-1	Layout Plan
	GNS-2	Runway Profile		AMQ-2	Runway Profile
	GNS-3	Typical Cross Section		AMQ-3	Typical Cross Section
	GNS-4	Pavement Plan		AMQ-4	Pavement Plan
2. Palembang	PLM-1	Layout Plan	7. Ternate	TTE-1	Layout Plan
	PLM-2	Runway Profile		TTE-2	Detailed Plan
	PLM-3	Typical Cross Section		TTE-3	Runway Profile
	PLM-4	Pavement Plan		TTE-4	Typical Cross Section
3. Semarang	SRG-1	Layout Plan		TTE-5	Pavement Plan
	SRG-2	Terminal Area Layout Plan		TTE-6	Terminal Area Layout Plan
	SRG-3	Floor Plan		TTE-7	Floor Plan
	SRG-4	Section A		TTE-8	Section
	SRG-5	Section B	8. Mataram	AMI-1	Layout Plan
4. Pontianak	PNK-1	Layout Plan		AMI-2	Detailed Plan
	PNK-2	Detailed Plan		AMI-3	Runway Profile
	PNK-3	Runway Profile		AMI-4	Typical Cross Section
	PNK-4	Typical Cross Section A		AMI-5	Pavement Plan
	PNK-5	Typical Cross Section B	9. Bima	BMU-1	Layout Plan
	PNK-6	Pavement Plan		BMU-2	Detailed Plan
	PNK-7	Terminal Area Layout Plan		BMU-3	Runway Profile
	PNK-8	Floor Plan		BMU-4	Typical Cross Section
	PNK-9	Section		BMU-5	Pavement Plan
5. Sampit	SMQ-1	Layout Plan	10. Merauke	MKQ-1	Layout Plan
	SMQ-2	Runway Profile		MKQ-2	Runway Profile
	SMQ-3	Typical Cross Section		MKQ-3	Typical Cross Section
	SMQ-4	Pavement Plan		MKQ-4	Pavement Plan
				MKQ-5	Terminal Area Layout Plan
				MKQ-6	Floor Plan
				MKQ-7	Section
				MKQ-8	Detail

1. Gunung Sitoli — GNS
 2. Palembang — PLM
 3. Semarang — SRG
 4. Pontianak — PNK
 5. Sampit — SMQ
 6. Ambon — AMQ
 7. Ternate — TTE
 8. Mataram — AMI
 9. Bima — BMU
 10. Merauke — MKQ

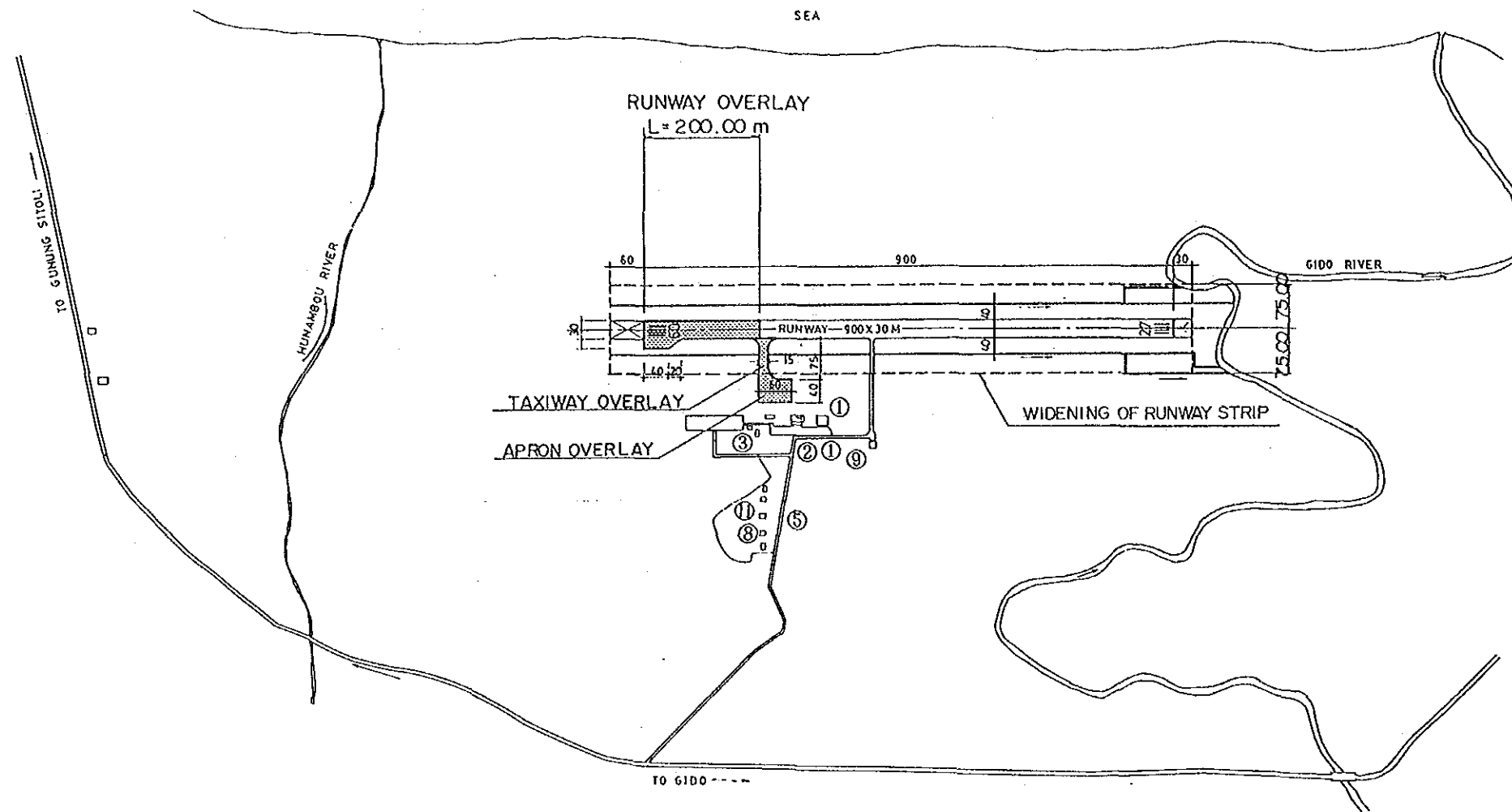

BASIC DATA TABLE			
AIRPORT CLASS	IV	RUNWAY DIRECTION	09-27
AIRPORT STATUS	DOMESTIC	INSTRUMENT RUNWAY	
AIRPORT ELEVATION	3M	PAVEMENT STRENGTH	
AIRPORT REF. POINT (ARP) COORDINATES	01° 16' N 97° 37' E	NAVIGATIONAL AIDS	
AIRPORT REF. TEMP		DISTANCE FROM CITY	18KM

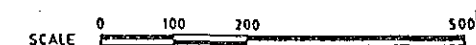

MAJOR BUILDINGS					
No.	Name of Building	tick if available	No.	Name of Building	tick if available
1	Passenger Terminal	✓	7	VIP Building	
2	Administration Building	✓	8	Main Power House	✓
3	Operations Building	✓	9	Fire Station	✓
4	Control Tower		10	Fuel Farm	
5	Workshop	✓	11	Staff Housing	✓
6	Cargo Terminal Building				

LEGEND	
—x—x—	Fence
====	Ditch

STUDY ON THE MASTER PLAN OF AIRPORT MAINTENANCE AND REHABILITATION	
NAME OF AIRPORT : BINAKA/GUNUNG SITOLI	SCALE : 1/10,000
NAME OF DRAWING : Layout Plan	DWG NO : GNS-1

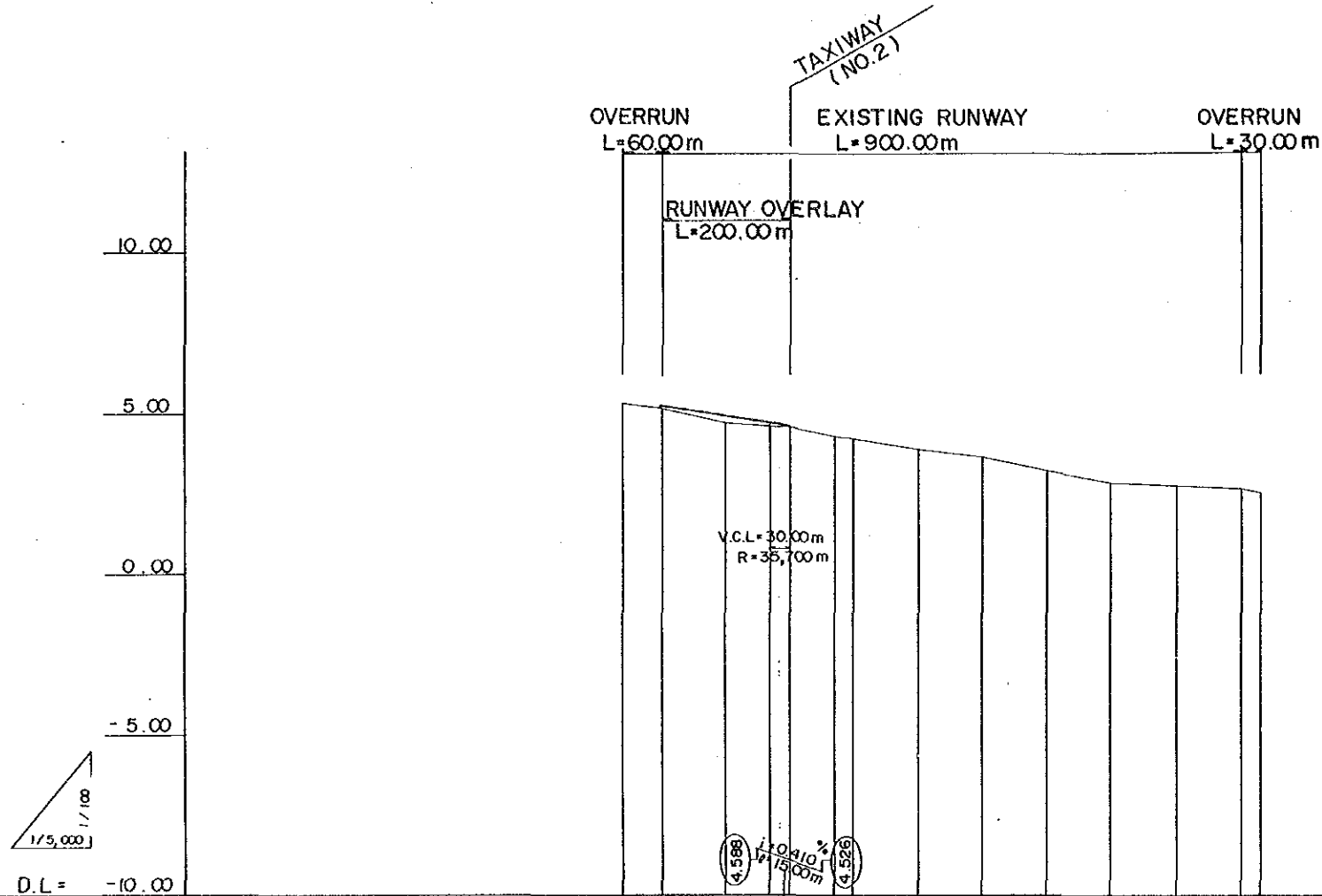

SLOPE			i = 0.326% R = 185,000m																			
OVERLAY THICKNESS			0.074	0.176	0.085	0.000																
PROPOSED HEIGHT			5.192	4.865	4.637	4.585	4.526															
GROUND HEIGHT		5.039	5.118	4.687	4.541	4.534	4.526	4.239	4.189	3.840	3.593	3.183	2.783	2.651	2.571	2.461						
ACCUMULATED DISTANCE		60.00	0.00	100.00	170.00	185.00	200.00	270.00	300.00	400.00	500.00	600.00	700.00	800.00	900.00	930.00						
STATION		-60.00	NO. 0	NO. 1	+70.00	+185.00	NO. 2	+70.00	NO. 3	NO. 4	NO. 5	NO. 6	NO. 7	NO. 8	NO. 9	+300.00						



STUDY ON THE MASTER PLAN OF AIRPORT MAINTENANCE AND REHABILITATION	
NAME OF AIRPORT : BINAKA/GUNUNG SITOLI	SCALE : V = 1/200 H = 1/10,000
NAME OF DRAWING : Runway Profile	DWG NO : GNS-2

NO. 2

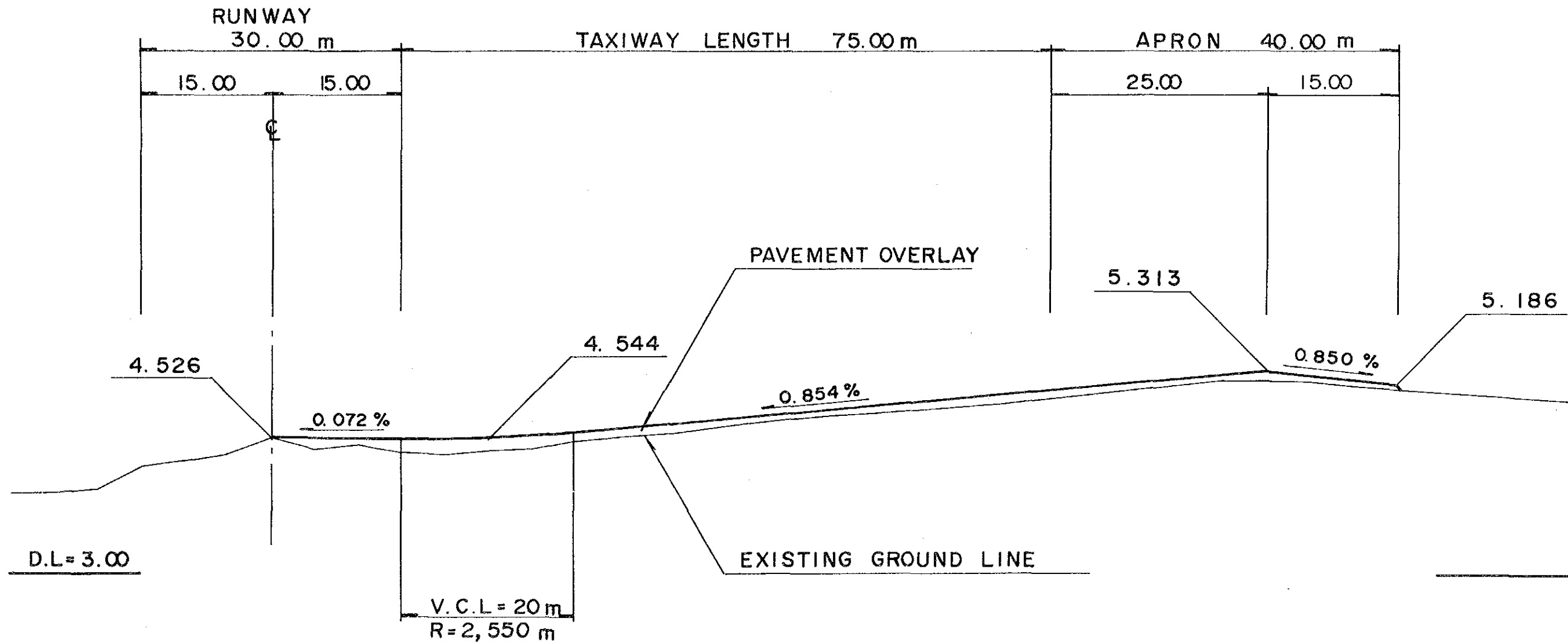

TAXIWAY AND APRON OVERLAY

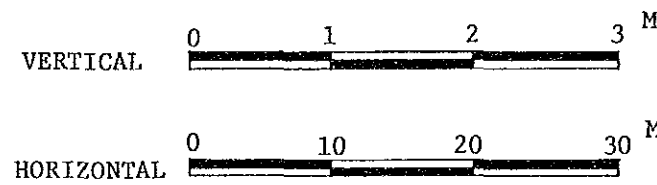

STUDY ON THE MASTER PLAN OF AIRPORT MAINTENANCE AND REHABILITATION	
NAME OF AIRPORT : BINAKA/GUNUNG SITOLI	SCALE : V=1/50 H=1/500
NAME OF DRAWING : Typical Cross Section	DWG NO : GNS-3

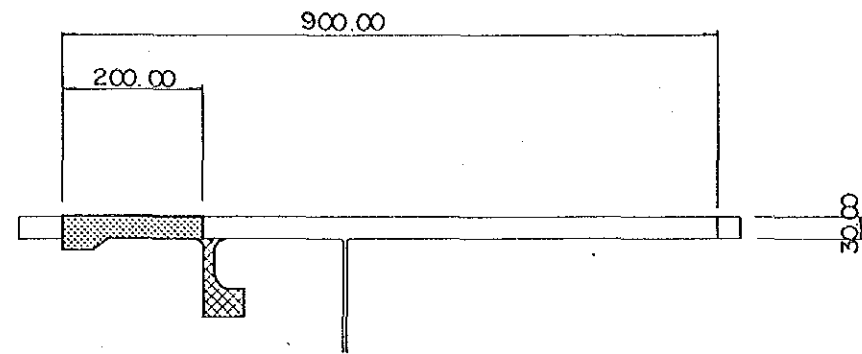

RUNWAY OVERLAY

TAXIWAY AND
APRON OVERLAY

PT-1

PT-2

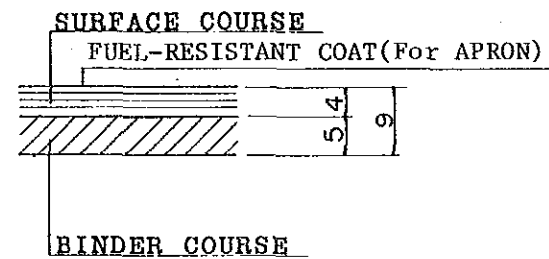
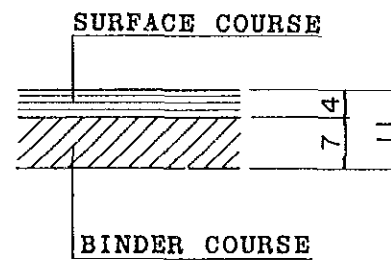

SCALE 0 100 200 300 M

STUDY ON THE MASTER PLAN OF AIRPORT MAINTENANCE AND REHABILITATION	
NAME OF AIRPORT :	SCALE :
BINAKA/GUNUNG SITOLI	1/10,000
NAME OF DRAWING :	DWG NO :
Pavement Plan	GNS-4

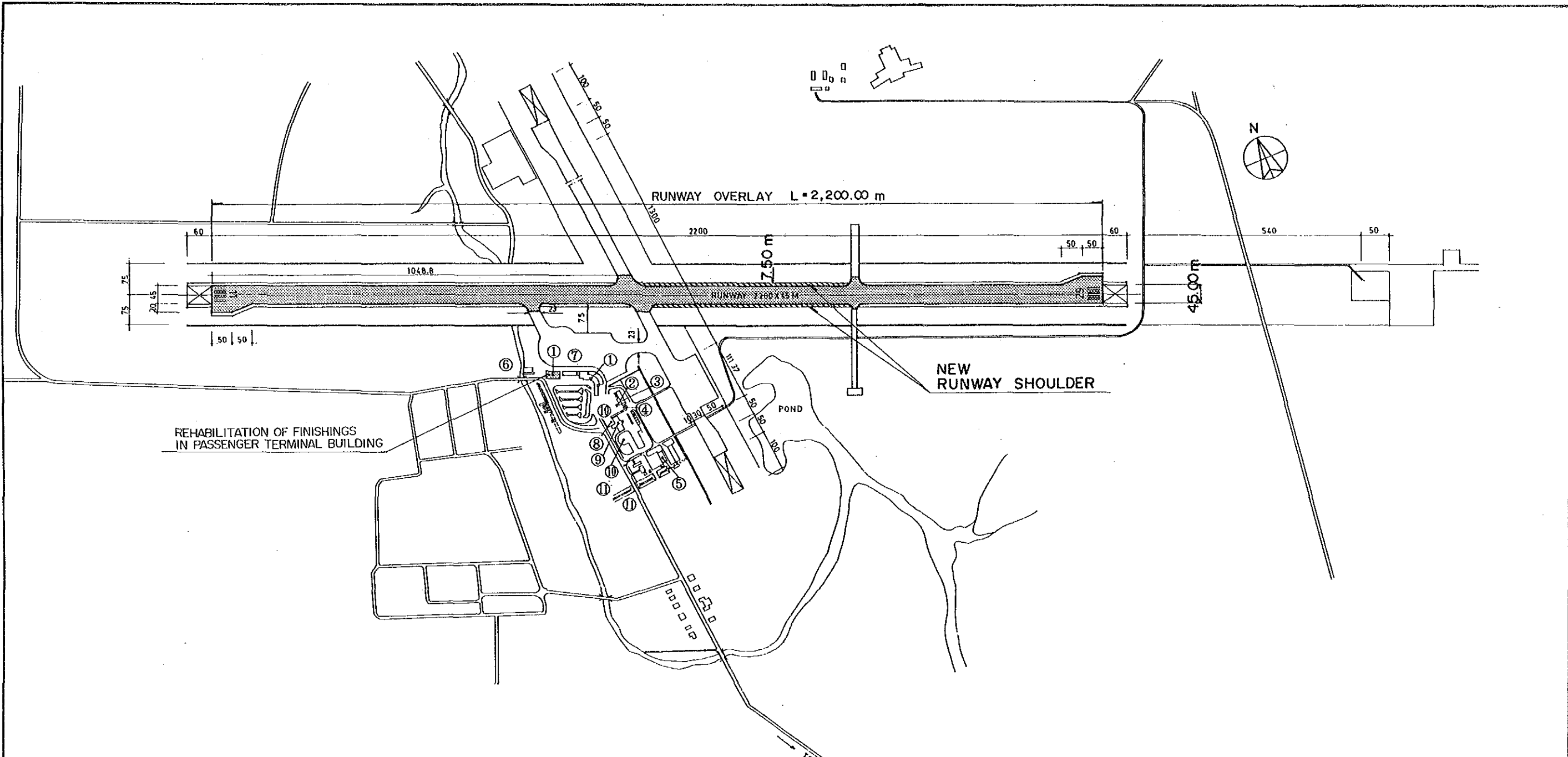

BASIC DATA TABLE			
AIRPORT CLASS	II	RUNWAY DIRECTION	11-29
AIRPORT STATUS	INT'L/DOM	INSTRUMENT RUNWAY	
AIRPORT ELEVATION	11.3M	PAVEMENT STRENGTH	PCN 35 FCXU
AIRPORT REF. POINT (ARP) COORDINATES	02° 54' S 104° 42' E	NAVIGATIONAL AIDS	
AIRPORT REF. TEMP	32.9°C	DISTANCE FROM CITY	11KM

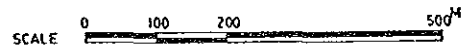

MAJOR BUILDINGS					
No.	Name of Building	tick if available	No.	Name of Building	tick if available
1	Passenger Terminal	✓	7	VIP Building	✓
2	Administration Building	✓	8	Main Power House	✓
3	Operations Building	✓	9	Fire Station	✓
4	Control Tower	✓	10	Fuel Farm	✓
5	Workshop	✓	11	Staff Housing	✓
6	Cargo Terminal Building	✓			

LEGEND	
—x—x—	Fence
====	Ditch

STUDY ON THE MASTER PLAN OF AIRPORT MAINTENANCE AND REHABILITATION	
NAME OF AIRPORT :	SCALE :
ST, MAHMUD BADARUDDIN/PALEMBANG	1/10,000
NAME OF DRAWING :	DWG NO :
Layout Plan	PLM-1

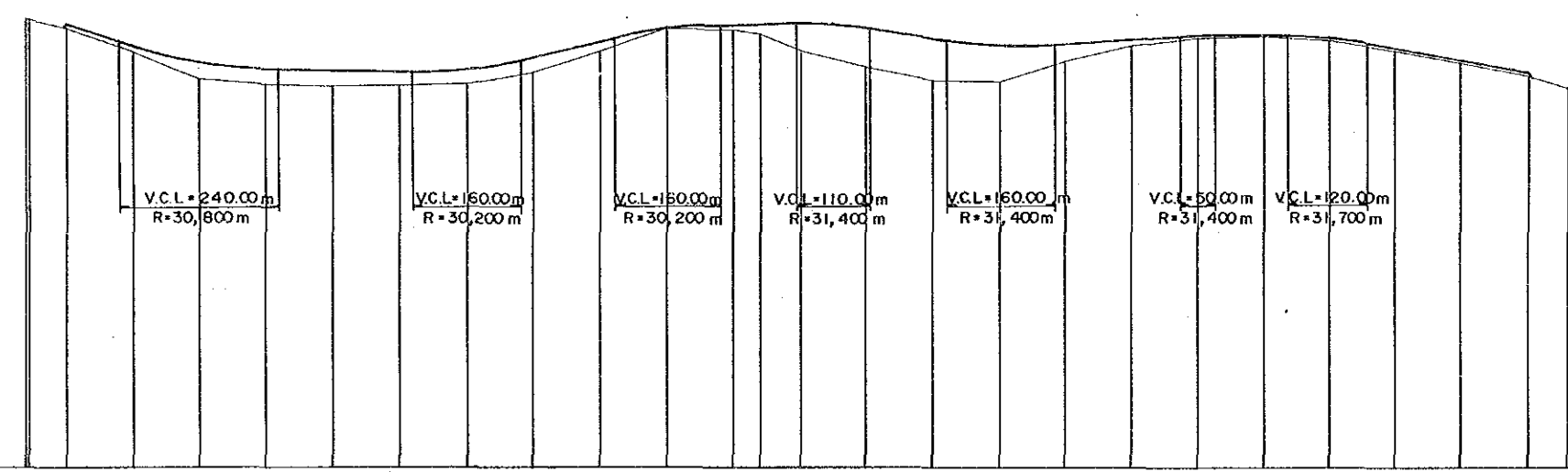
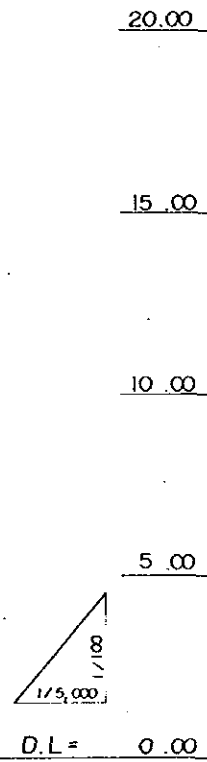
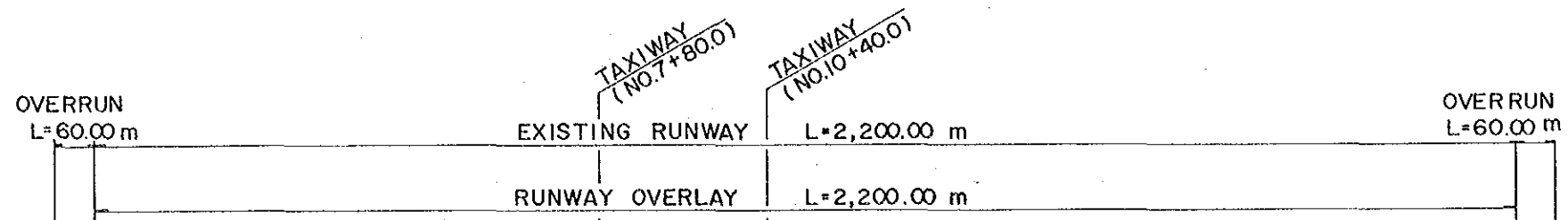

SLOPE	13.254 $i = 0.780\%$ $L = 200.00\text{ m}$		LEVEL $L = 400.00\text{ m}$		11.694 $i = 0.530\%$ $L = 300.00\text{ m}$		LEVEL $L = 250.00\text{ m}$		13.283 $i = 0.350\%$ $L = 250.00\text{ m}$		2.407 $i = 0.159\%$ $L = 300.00\text{ m}$		LEVEL $L = 200.00\text{ m}$		2.884 $i = 0.378\%$ $L = 300.00\text{ m}$		11.750										
OVERLAY THICKNESS		0.086	0.054	0.304	0.227	0.286	0.265	0.333	0.428	0.324	0.064	0.192	0.362	0.634	1.039	1.165	1.227	1.017	0.495	0.192	0.092	0.078	0.130	0.129	0.111	0.096	
PROPOSED HEIGHT		13.254	12.481	11.928	11.701	11.694	11.694	11.800	12.224	12.754	13.177	13.283	13.283	13.283	13.235	13.108	12.758	12.509	12.566	12.725	12.874	12.884	12.884	12.827	12.506	12.128	11.750
GROUND HEIGHT	13.453	13.453	13.168	12.427	11.624	11.474	11.408	11.429	11.467	11.796	12.430	13.113	13.091	12.931	12.449	12.196	11.531	11.492	12.071	12.533	12.782	12.806	12.806	12.697	12.377	12.017	11.654
ACCUMULATED DISTANCE	60.00	120.00	180.00	240.00	300.00	360.00	420.00	480.00	540.00	600.00	660.00	720.00	780.00	840.00	900.00	960.00	1020.00	1080.00	1140.00	1200.00	1260.00	1320.00	1380.00	1440.00	1500.00	1560.00	1620.00
STATION	-60.00	0.00	100.00	200.00	300.00	400.00	500.00	600.00	700.00	800.00	900.00	1000.00	1100.00	1200.00	1300.00	1400.00	1500.00	1600.00	1700.00	1800.00	1900.00	2000.00	2100.00	2200.00	2300.00	2400.00	2500.00

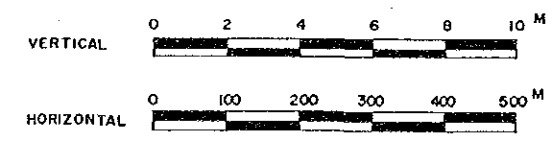

STUDY ON THE MASTER PLAN OF AIRPORT MAINTENANCE AND REHABILITATION	
NAME OF AIRPORT : ST. MAHMUD BADARUDDIN/PALEMBANG	SCALE : V = 1/200 H = 1/10,000
NAME OF DRAWING : Runway Profile	DWG NO : PLM-2

NO. 8

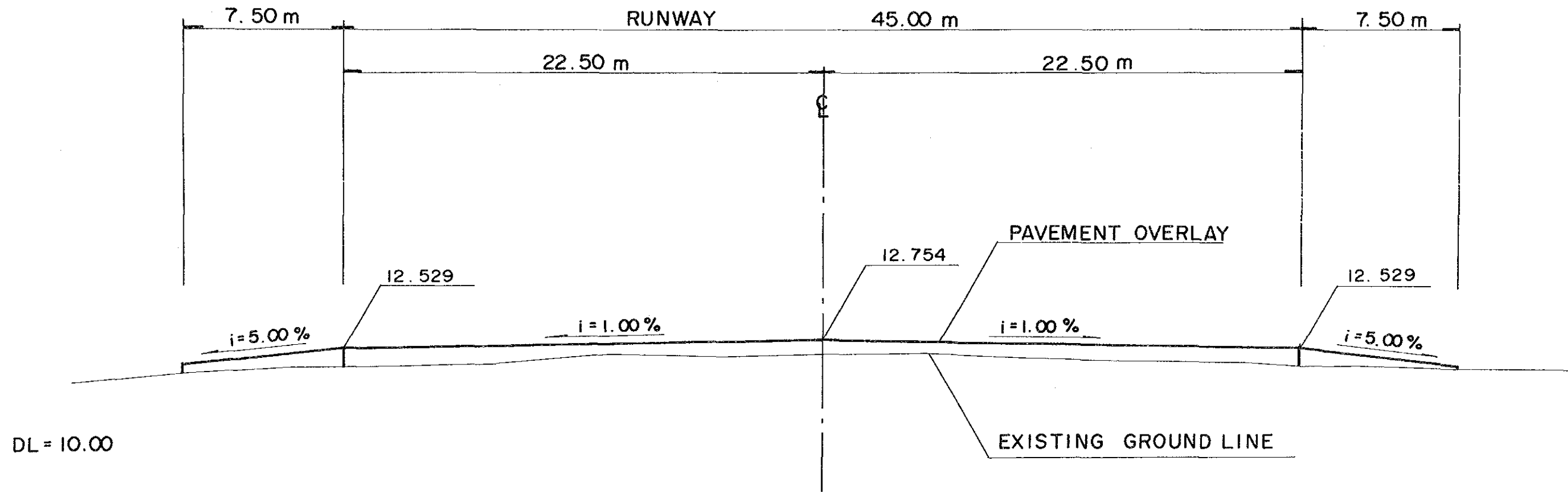

RUNWAY OVERLAY

STUDY ON THE MASTER PLAN OF AIRPORT MAINTENANCE AND REHABILITATION	
NAME OF AIRPORT : ST, MAHMUD BADARUDDIN/PALEMBANG	SCALE : V = 1 / 50 H = 1 / 200
NAME OF DRAWING : Typical Cross Section	DWG NO : PLM-3

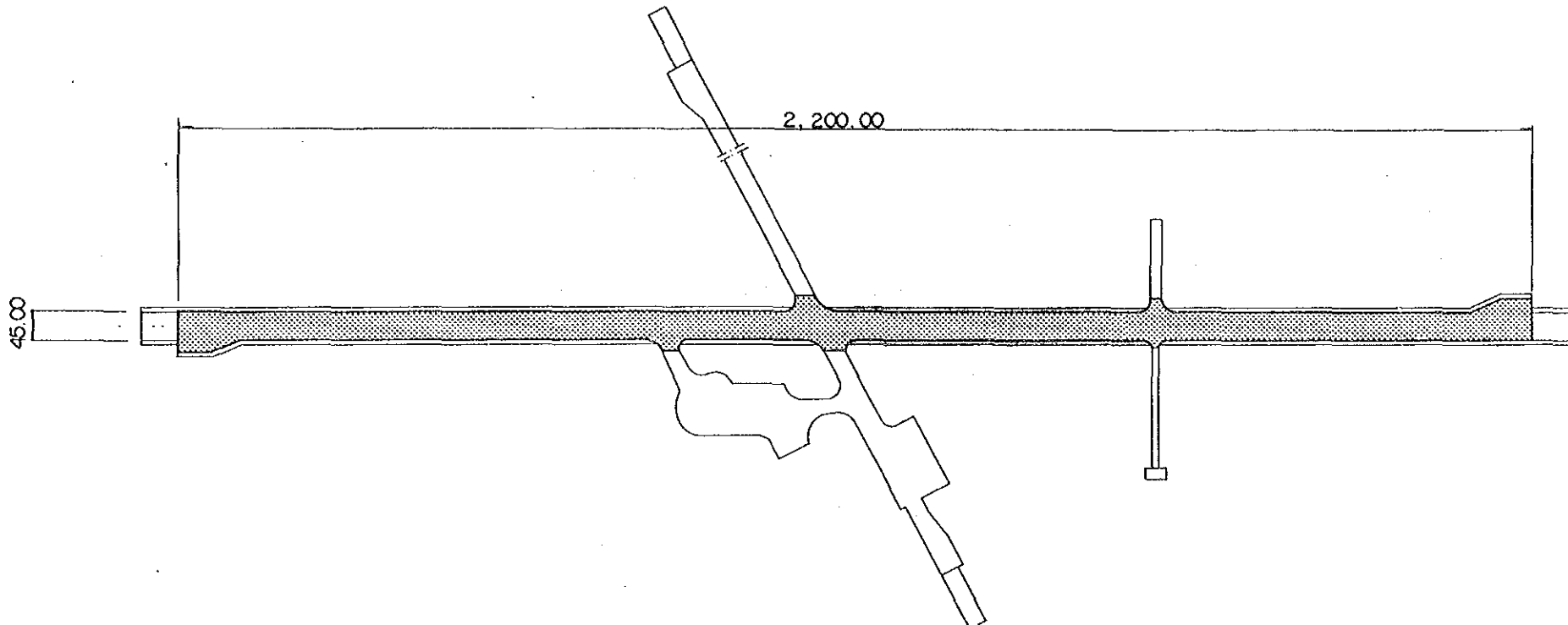

RUNWAY OVERLAY

PT-1

NEW SHOULDER

PT-2

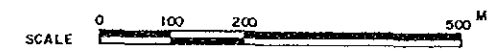
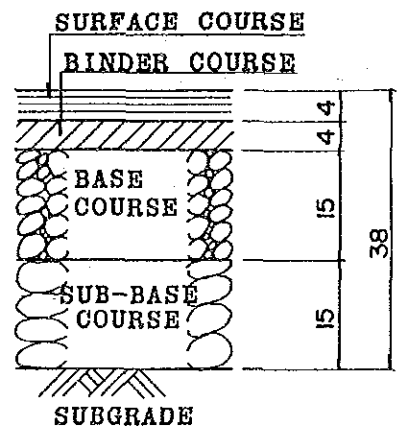
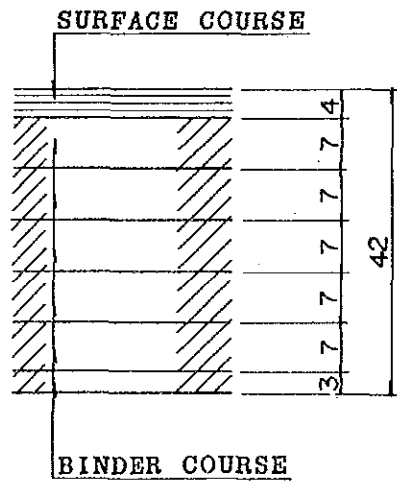

STUDY ON THE MASTER PLAN OF AIRPORT MAINTENANCE AND REHABILITATION	
NAME OF AIRPORT :	SCALE :
ST, MAHMUD BADARUDDIN/PALEMBANG	1/10,000
NAME OF DRAWING :	DWG NO :
Pavement Plan	PLM-4

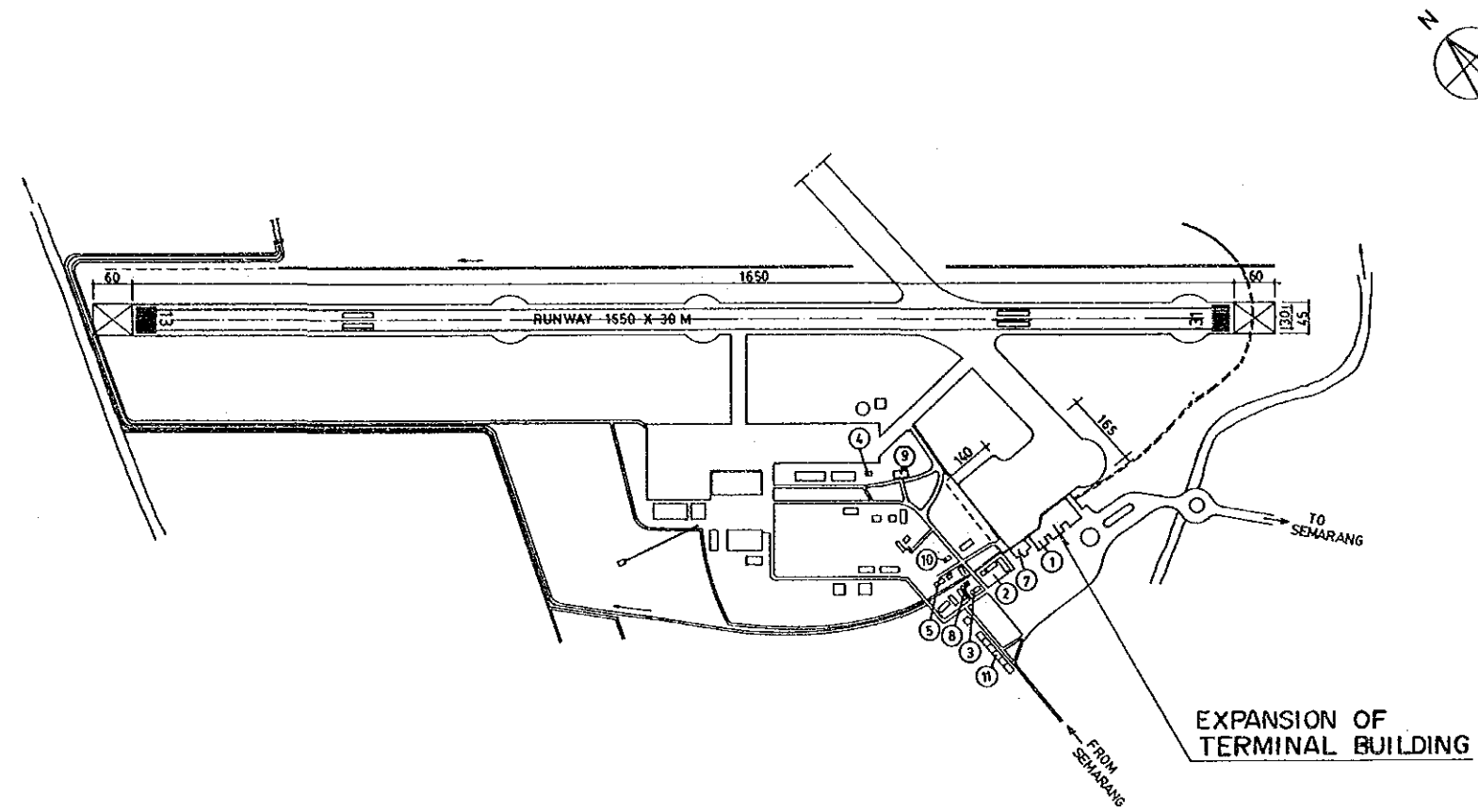

BASIC DATA TABLE			
AIRPORT CLASS	II	RUNWAY DIRECTION	13-31
AIRPORT STATUS	DOMESTIC	INSTRUMENT RUNWAY	
AIRPORT ELEVATION	3M	PAVEMENT STRENGTH	PCN 23 FDYU
AIRPORT REF. POINT (ARP) COORDINATES	06° 59' S 110° 23' E	NAVIGATIONAL AIDS	NDB, VOR, DME
AIRPORT REF. TEMP	34.5°C	DISTANCE FROM CITY	4.5 KM

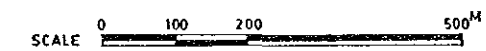

MAJOR BUILDINGS					
No.	Name of Building	tick if available	No.	Name of Building	tick if available
1	Passenger Terminal	✓	7	VIP Building	✓
2	Administration Building	✓	8	Main Power House	✓
3	Operations Building	✓	9	Fire Station	✓
4	Control Tower	✓	10	Fuel Farm	✓
5	Workshop	✓	11	Staff Housing	✓
6	Cargo Terminal Building				

LEGEND	
—x—x—	Fence
====	Ditch

STUDY ON THE MASTER PLAN OF AIRPORT MAINTENANCE AND REHABILITATION	
NAME OF AIRPORT :	SCALE :
AHMAD YANI/SEMARANG	1/10,000
NAME OF DRAWING :	DWG NO :
Layout Plan	SRG-1

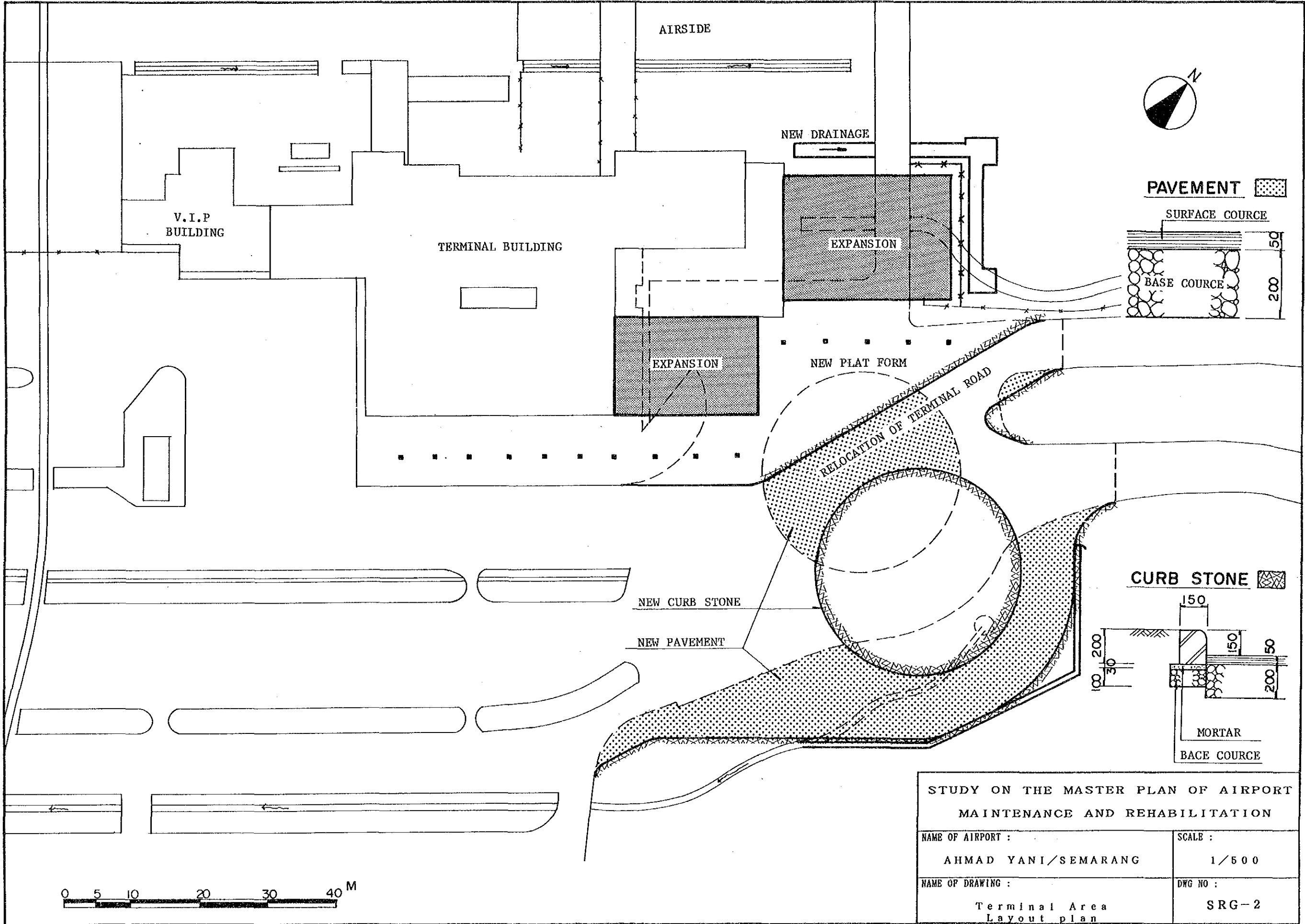

**STUDY ON THE MASTER PLAN OF AIRPORT
MAINTENANCE AND REHABILITATION**

NAME OF AIRPORT :	SCALE :
AHMAD YANI/SEMARANG	1/500
NAME OF DRAWING :	DWG NO :
Terminal Area Layout plan	SRG-2

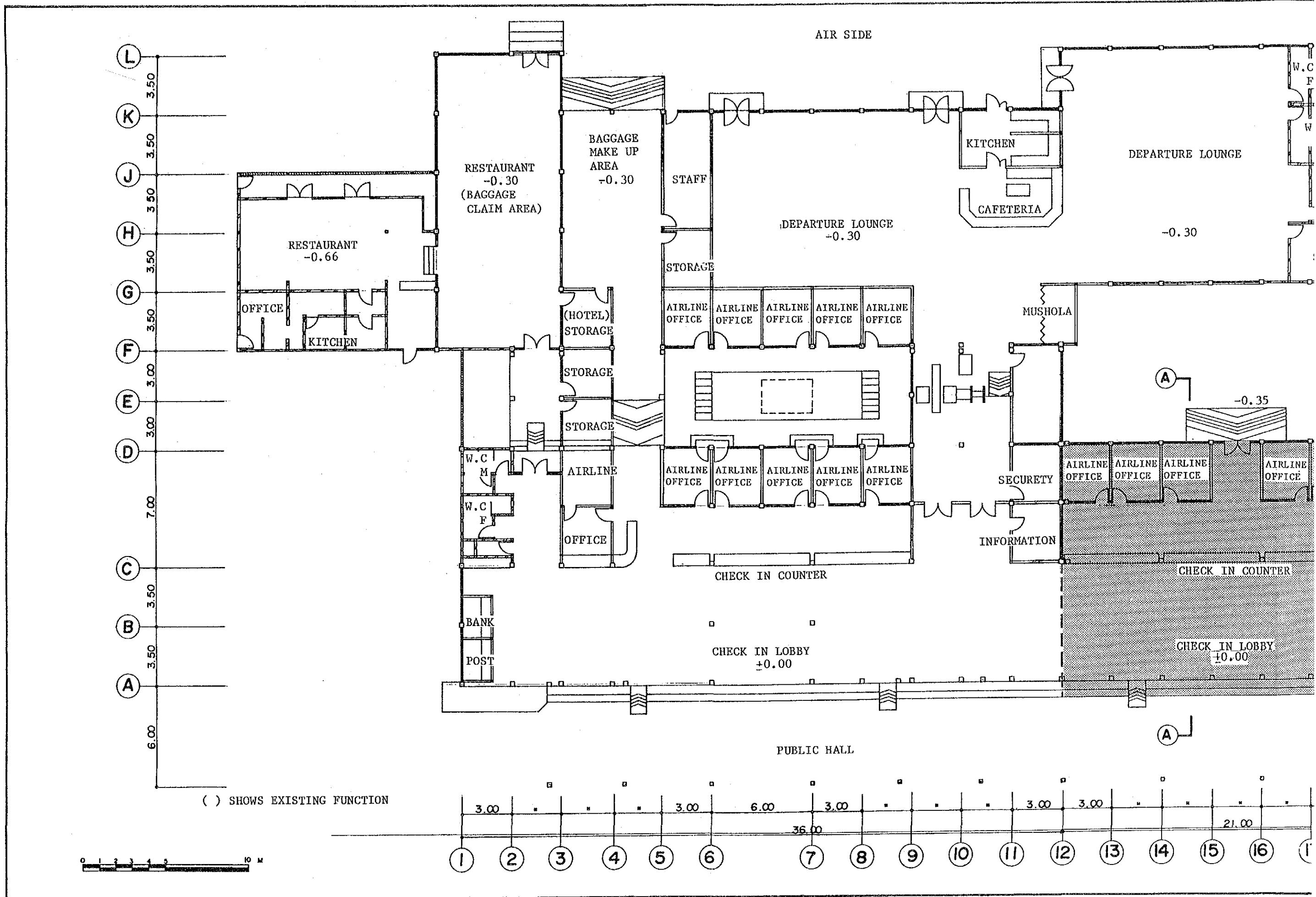

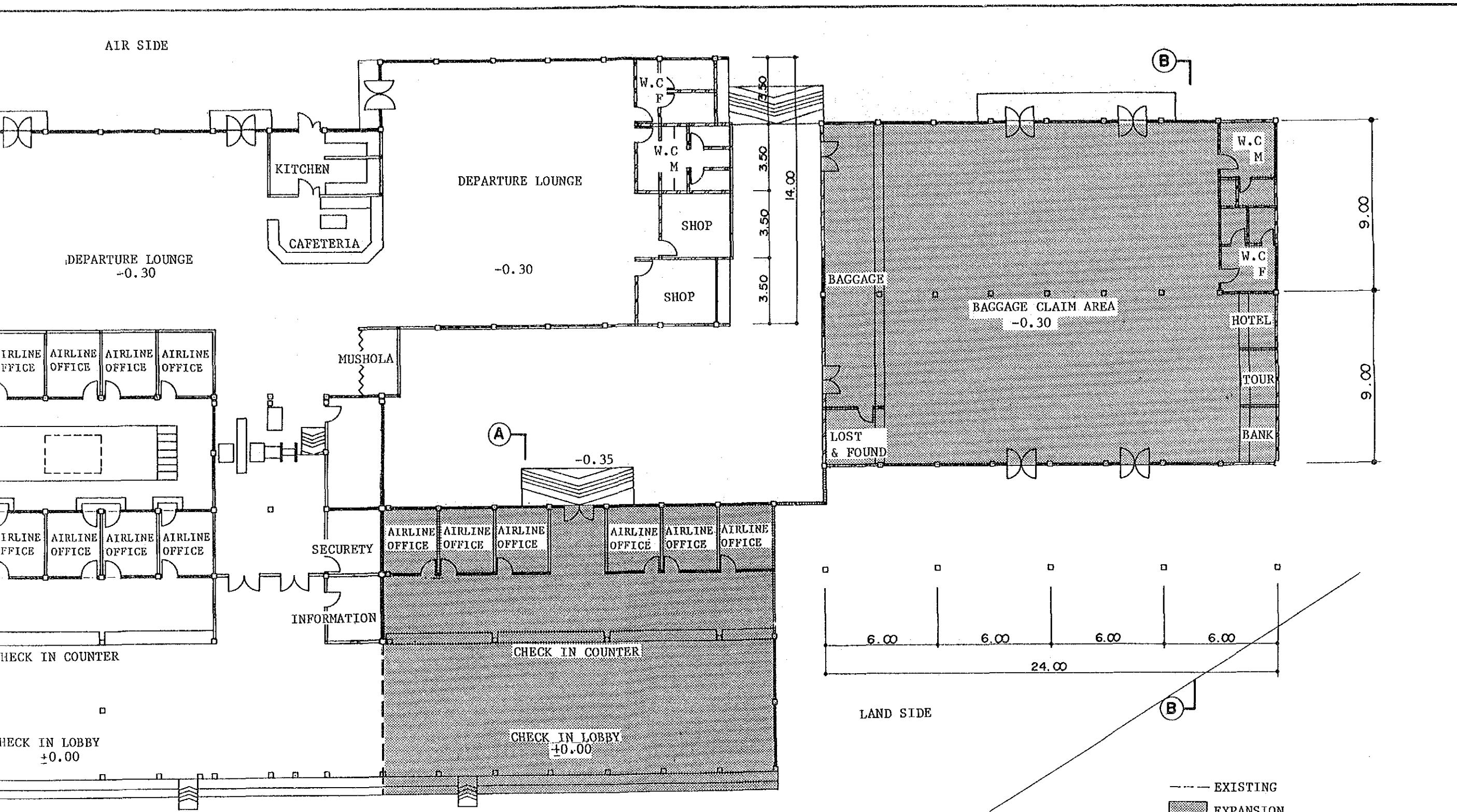

--- EXISTING
 ■ EXPANSION

STUDY ON THE MASTER PLAN OF AIRPORT MAINTENANCE AND REHABILITATION	
NAME OF AIRPORT : AHMAD YANI/SEMARANG	SCALE : 1/200
NAME OF DRAWING : Floor Plan	DWG NO : SRG-3

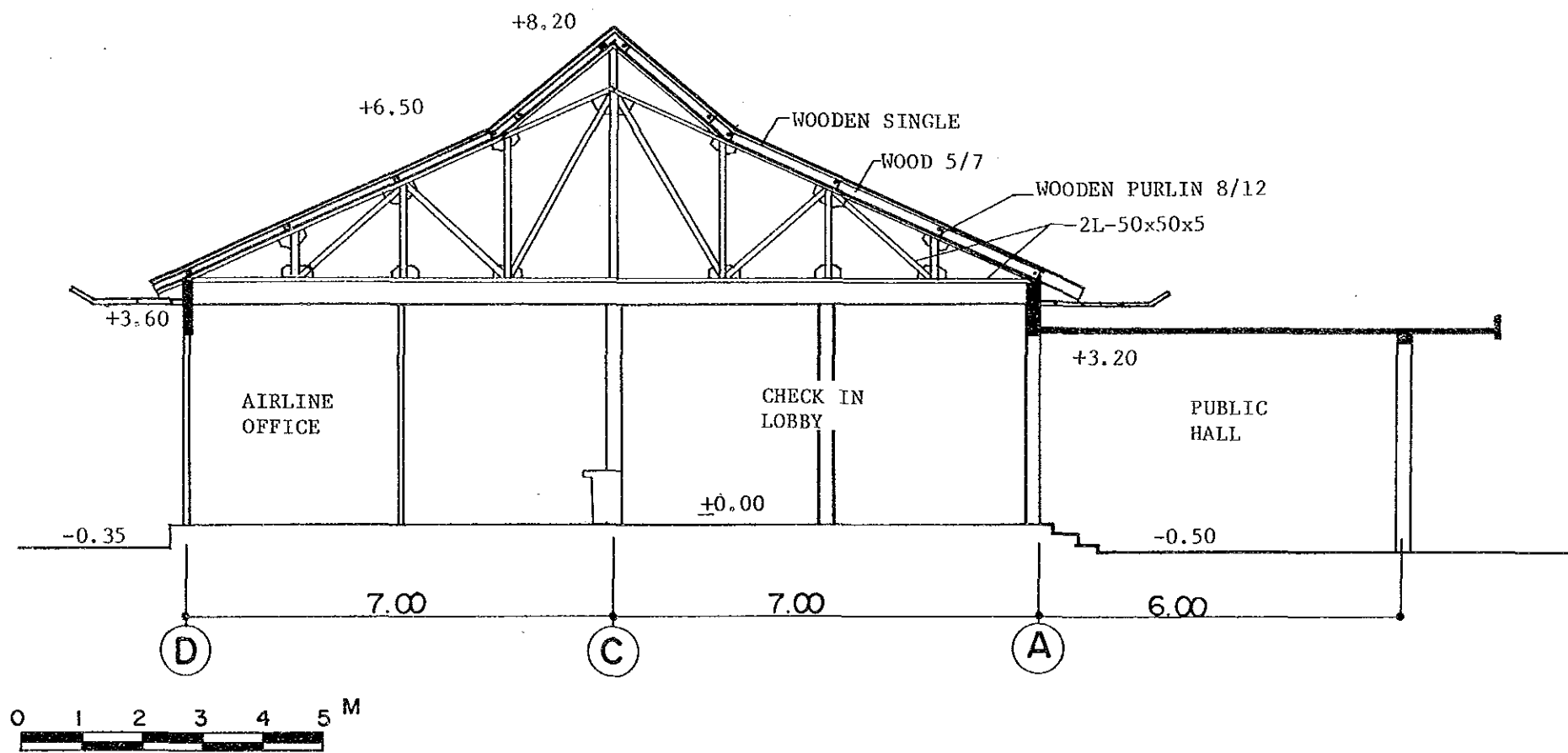

Ⓐ-Ⓐ SECTION

STUDY ON THE MASTER PLAN OF AIRPORT MAINTENANCE AND REHABILITATION	
NAME OF AIRPORT :	SCALE :
AHMAD YANI/SEMARANG	1/100
NAME OF DRAWING :	DWG NO :
Section A	SRG-4

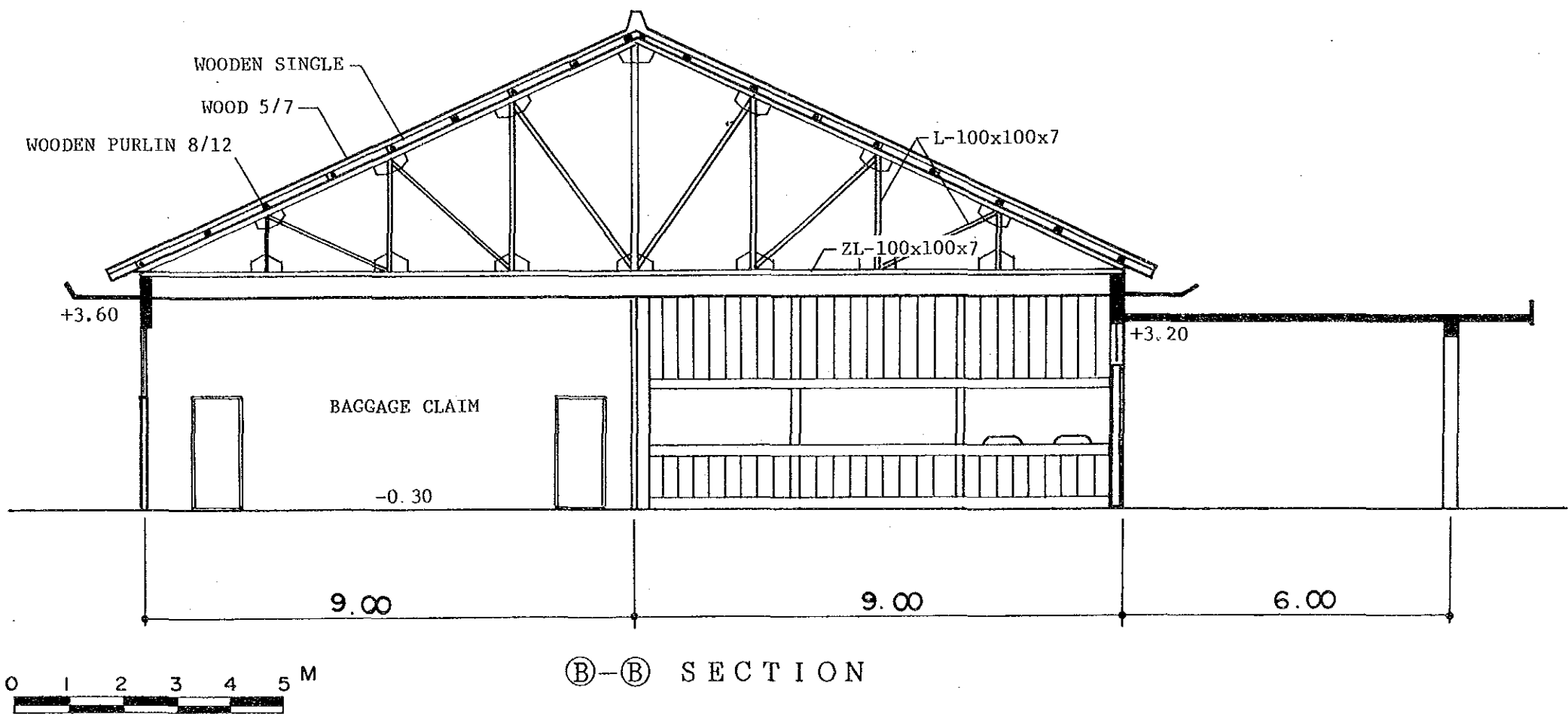

STUDY ON THE MASTER PLAN OF AIRPORT MAINTENANCE AND REHABILITATION	
NAME OF AIRPORT :	SCALE :
AHMAD YANI/SEMARANG	1/100
NAME OF DRAWING :	DWG NO :
Section B	SRG-5

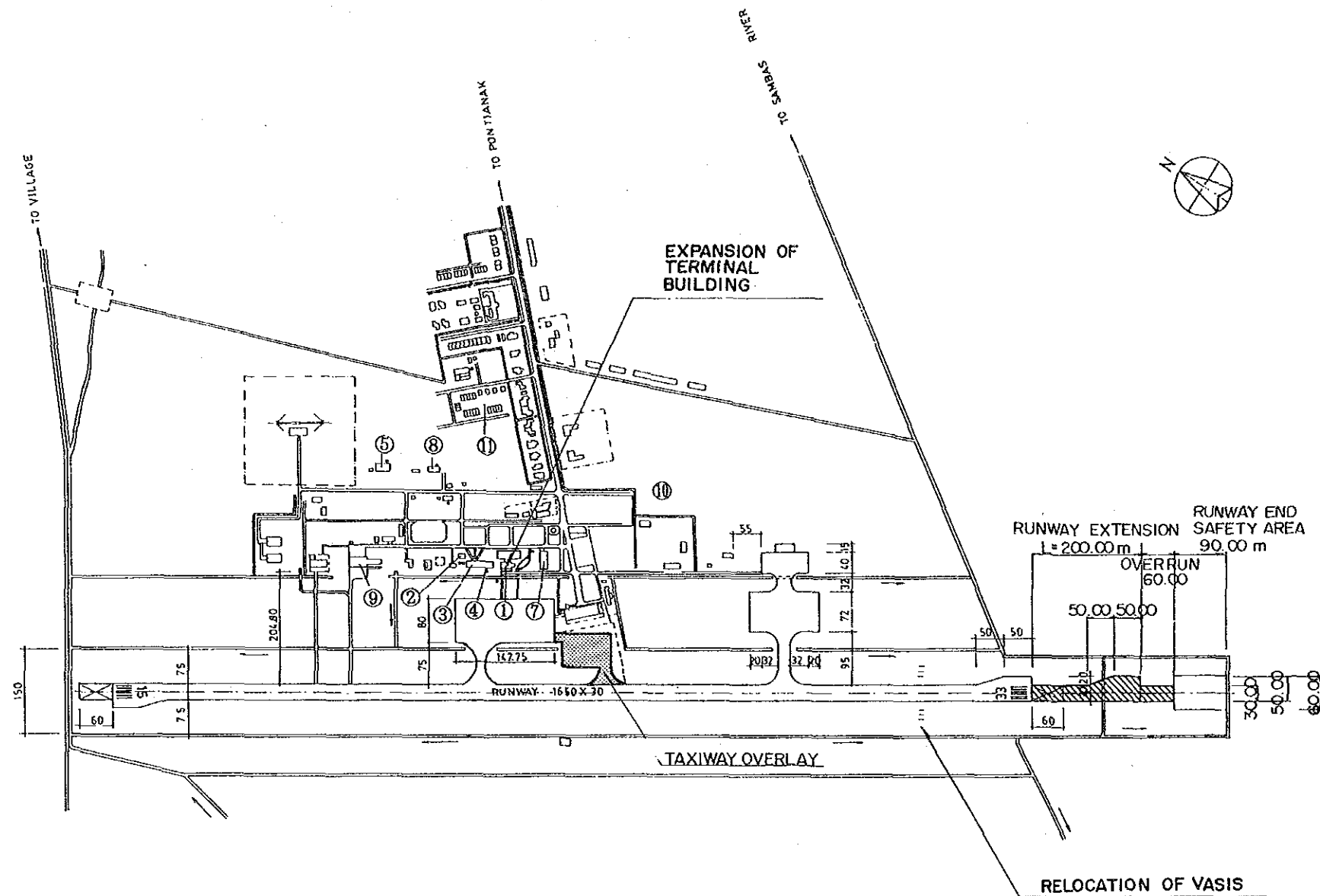

BASIC DATA TABLE			
AIRPORT CLASS	I	RUNWAY DIRECTION	15-33
AIRPORT STATUS	INT'L/DOM	INSTRUMENT RUNWAY	
AIRPORT ELEVATION	3M	PAVEMENT STRENGTH	PCN 20 FDYU
AIRPORT REF. POINT (ARP) COORDINATES	00° 09' S 109° 24' E	NAVIGATIONAL AIDS	NDB, VOR, ILS
AIRPORT REF. TEMP	24-31°C	DISTANCE FROM CITY	17KM

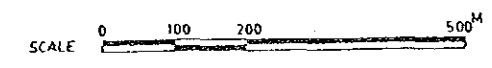

MAJOR BUILDINGS					
No.	Name of Building	tick if available	No.	Name of Building	tick if available
1	Passenger Terminal	✓	7	VIP Building	✓
2	Administration Building	✓	8	Main Power House	✓
3	Operations Building	✓	9	Fire Station	✓
4	Control Tower	✓	10	Fuel Farm	✓
5	Workshop	✓	11	Staff Housing	✓
6	Cargo Terminal Building				

LEGEND	
---x---x---	Fence
====	Ditch

STUDY ON THE MASTER PLAN OF AIRPORT MAINTENANCE AND REHABILITATION	
NAME OF AIRPORT :	SCALE :
SUPADIO/PONTIANAK	1/10,000
NAME OF DRAWING :	DWG NO :
Layout Plan	PNK-1

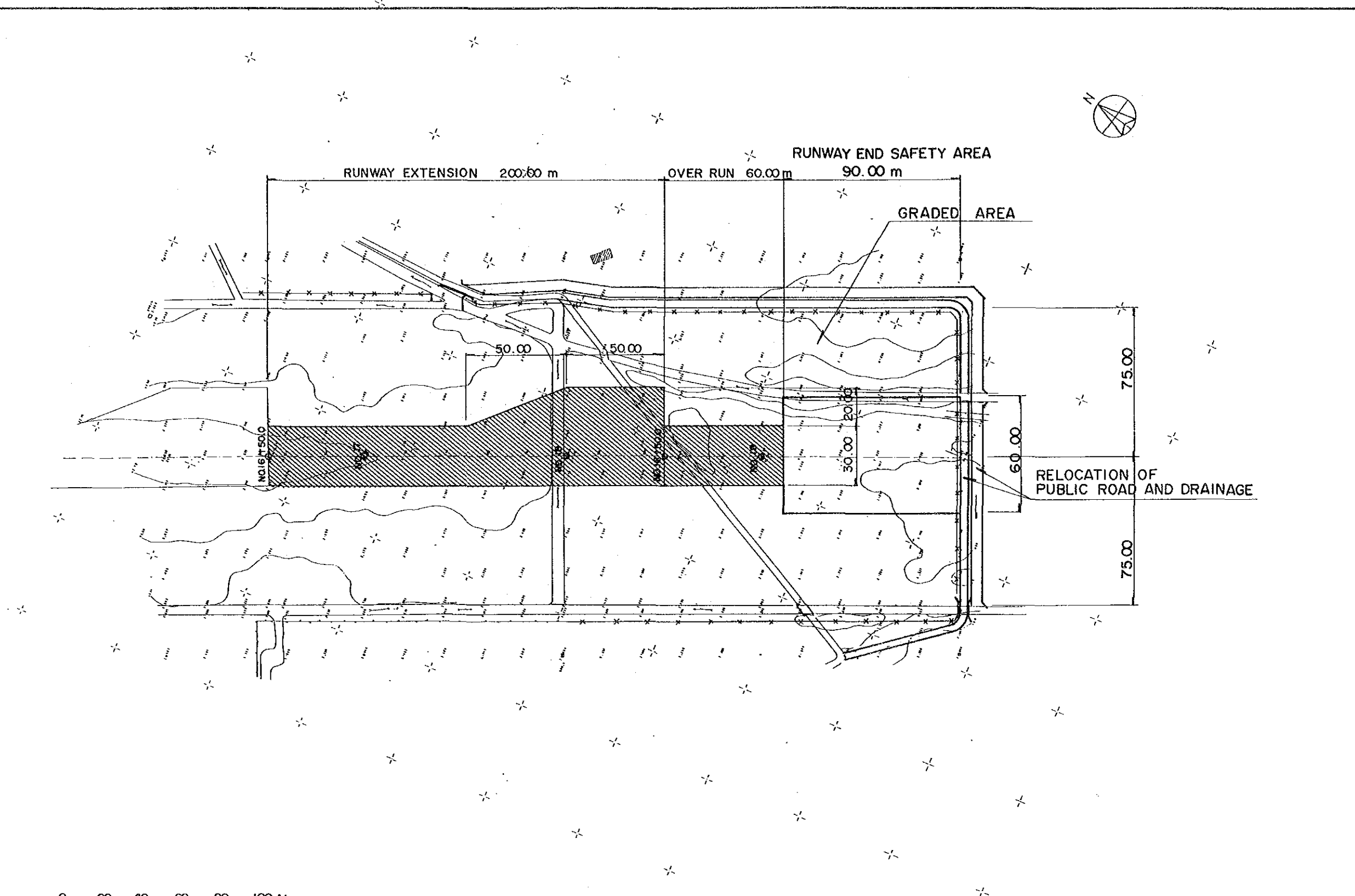

SCALE 0 20 40 60 80 100 M

STUDY ON THE MASTER PLAN OF AIRPORT MAINTENANCE AND REHABILITATION	
NAME OF AIRPORT :	SCALE :
SUPADIO/PONTIANAK	1/2,000
NAME OF DRAWING :	DWG NO :
Detailed Plan	PNK-2

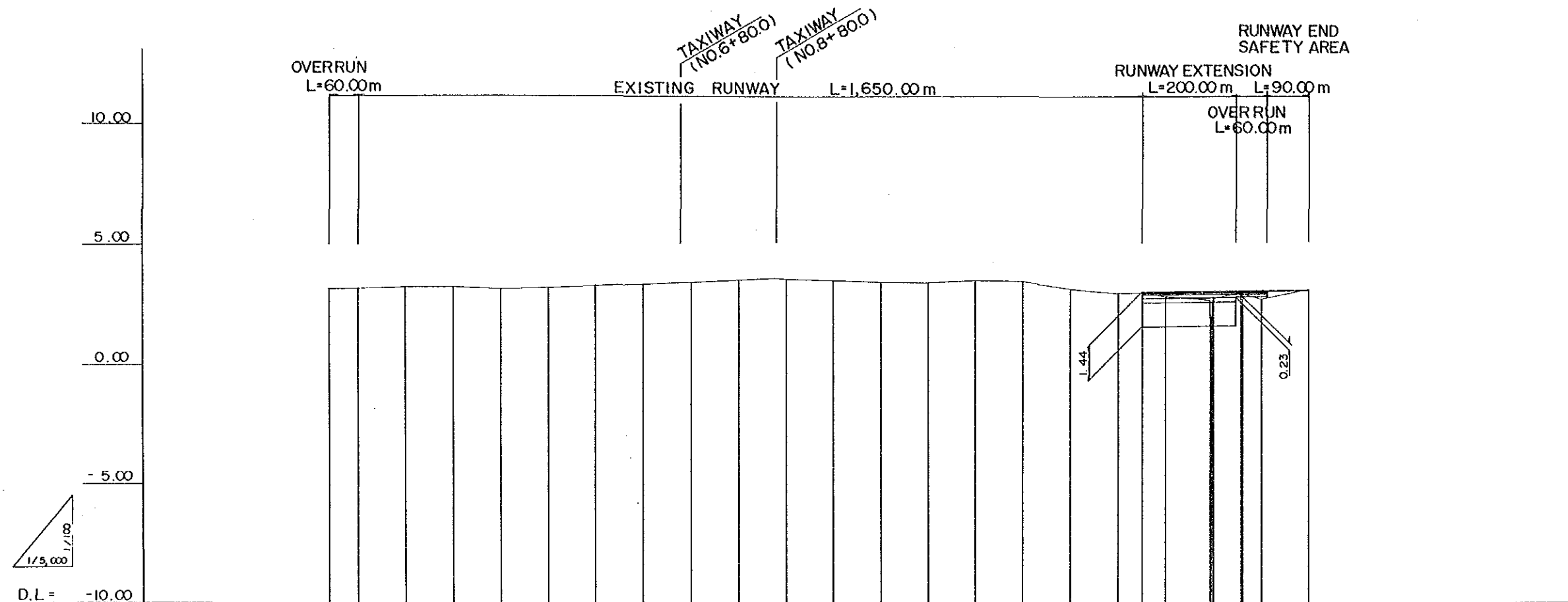

SLOPE	(2.903) $\frac{1}{5,000}$ $\frac{1}{350.00 \text{ m}}$ (0.938)																			
CUT OR BANK	0.000 0.154 0.309 0.464 0.619 0.774 0.929 1.084 1.239 1.394 1.549 1.704 1.859 2.014 2.169 2.324 2.479 2.634 2.789 2.944																			
PROPOSED HEIGHT	2.903 2.908 2.913 2.918 2.923 2.928 2.933 2.938 2.943 2.948 2.953 2.958 2.963 2.968 2.973 2.978 2.983 2.988 2.993 2.998																			
GROUND HEIGHT	3.153 3.179 3.232 3.221 3.134 3.181 3.230 3.306 3.395 3.543 3.517 3.437 3.392 3.366 3.428 3.383 3.041 2.898 2.903 2.754 2.589 2.304 2.487 2.643 2.800 2.957 2.857 2.672 2.989 2.990																			
ACCUMULATED DISTANCE	-60.00 0.00 100.00 200.00 300.00 400.00 500.00 600.00 680.80 700.00 800.00 880.80 900.00 1000.00 1100.00 1200.00 1300.00 1400.00 1500.00 1600.00 1660.00 1700.00 1796.00 1800.00 1800.00 1800.00 1800.00 1900.00 1900.00 2000.00																			
STATION	-60.0 NO. 0 NO. 1 NO. 2 NO. 3 NO. 4 NO. 5 NO. 6 +80.8 NO. 7 +80.8 NO. 8 +80.8 NO. 9 NO. 10 NO. 11 NO. 12 NO. 13 NO. 14 NO. 15 NO. 16 +50.0 NO. 17 +96.0 NO. 18 +2.0 NO. 19 +63.0 +110.0 NO. 20																			

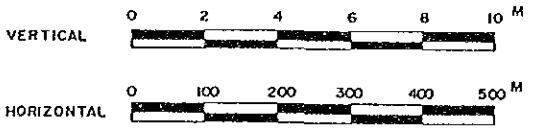

STUDY ON THE MASTER PLAN OF AIRPORT MAINTENANCE AND REHABILITATION	
NAME OF AIRPORT : SUPADIO/PONTIANAK	SCALE : V = 1/200 H = 1/10,000
NAME OF DRAWING : Runway Profile	DWG NO : PNK-3

NO. 19

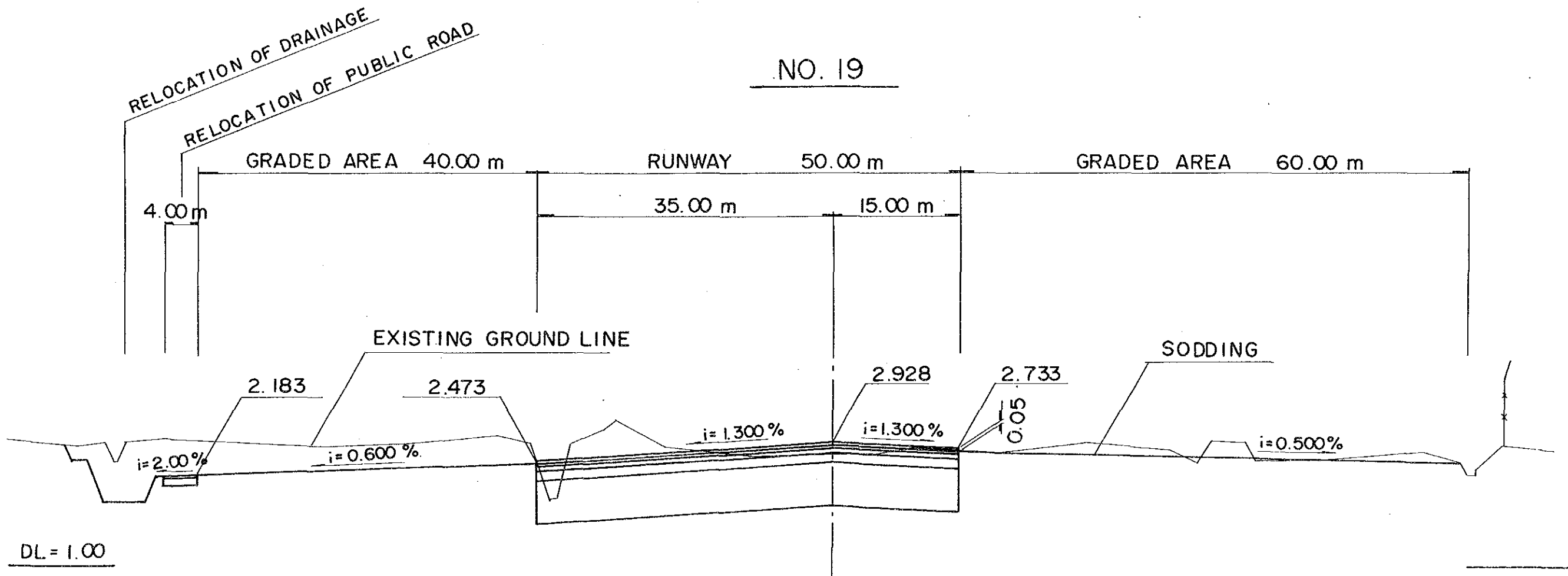

RUNWAY EXTENSION

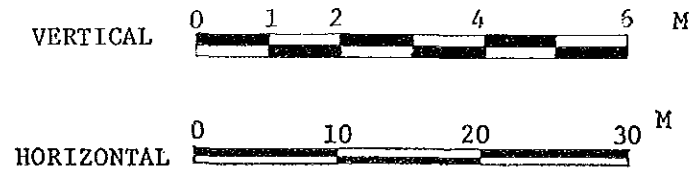

STUDY ON THE MASTER PLAN OF AIRPORT MAINTENANCE AND REHABILITATION	
NAME OF AIRPORT : SUPADIO/PONTIANAK	SCALE : V = 1/20 H = 1/500
NAME OF DRAWING : Typical Cross Section	DWG NO : PNK-4

NO.8 + 80

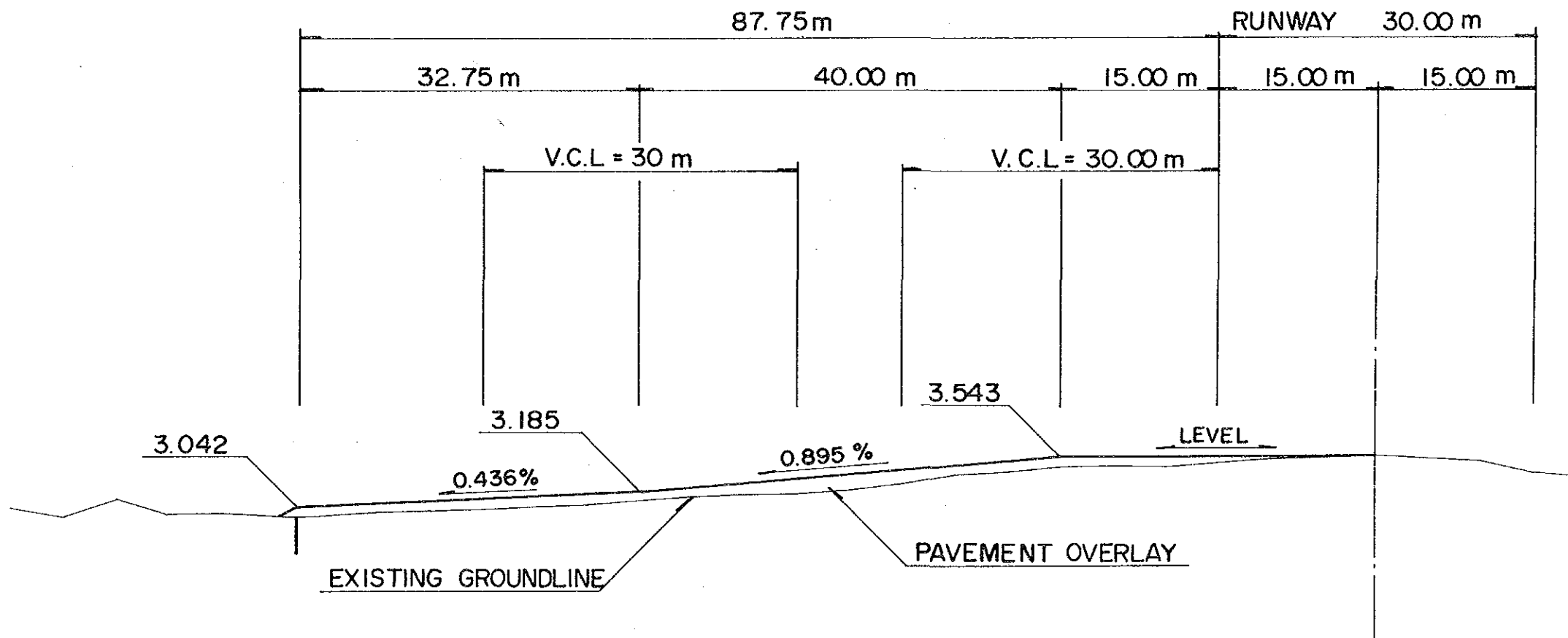

DL = 1.00

TAXIWAY AND APRON OVERLAY

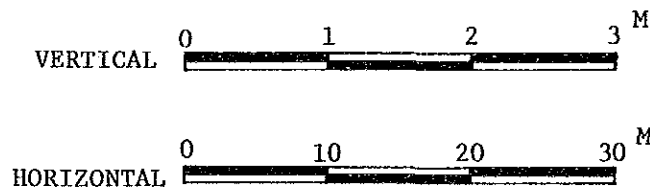

STUDY ON THE MASTER PLAN OF AIRPORT MAINTENANCE AND REHABILITATION	
NAME OF AIRPORT : SUPADIO/PONTIANAK	SCALE : V = 1/50 H = 1/500
NAME OF DRAWING : Typical Cross Section	DWG NO : PNK-5

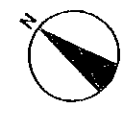
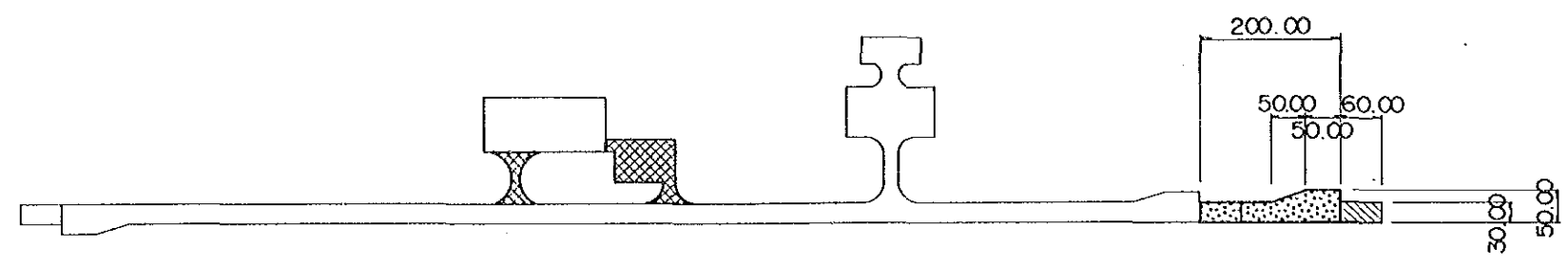

TAXIWAY AND
APRON OVERLAY

RUNWAY EXTENSION

OVERRUN

PT-1

PT-2

PT-3

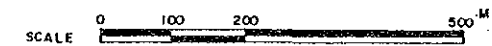
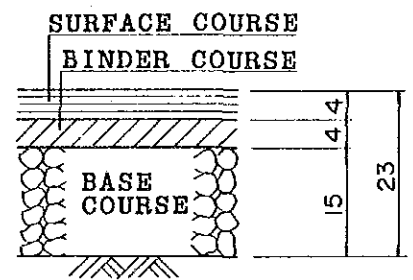
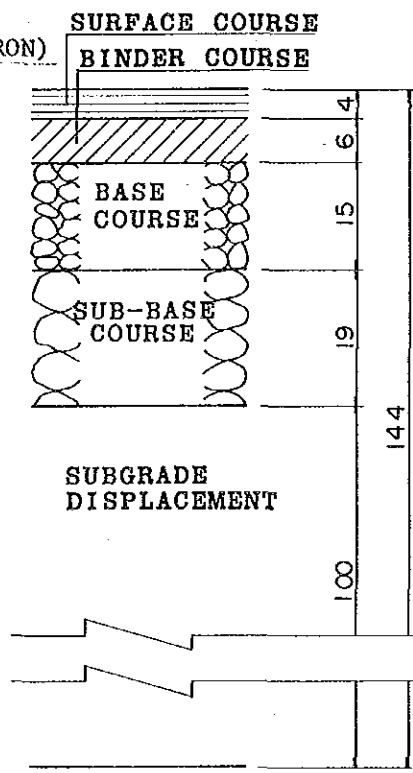
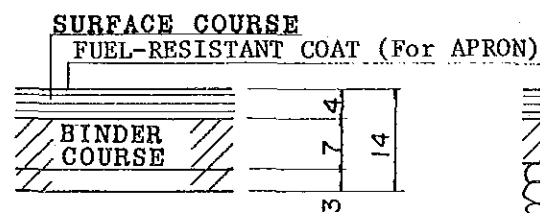

STUDY ON THE MASTER PLAN OF AIRPORT MAINTENANCE AND REHABILITATION	
NAME OF AIRPORT : SUPADIO/PONTIANAK	SCALE : 1/10,000
NAME OF DRAWING : Pavement Plan	DWG NO : PNK-6

AIRSIDE

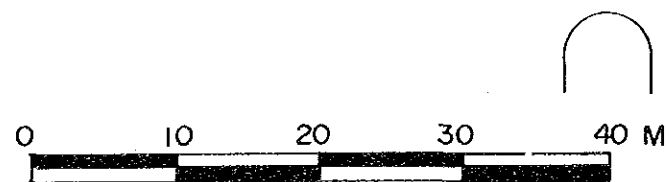
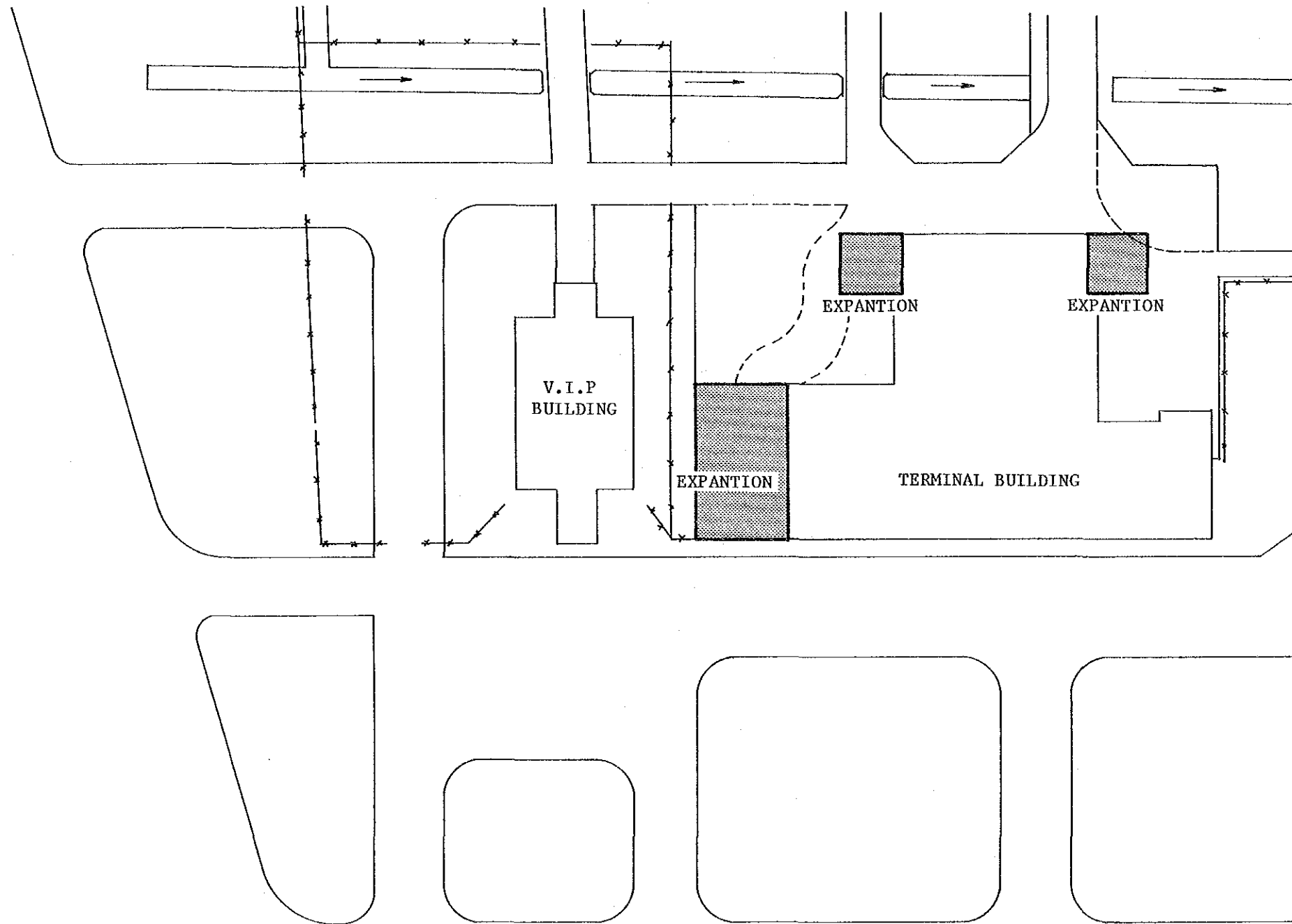

STUDY ON THE MASTER PLAN OF AIRPORT MAINTENANCE AND REHABILITATION	
NAME OF AIRPORT : SUPADIO/PONTIANAK	SCALE : 1/500
NAME OF DRAWING : Terminal Area Layout plan	DWG NO : PNK-7

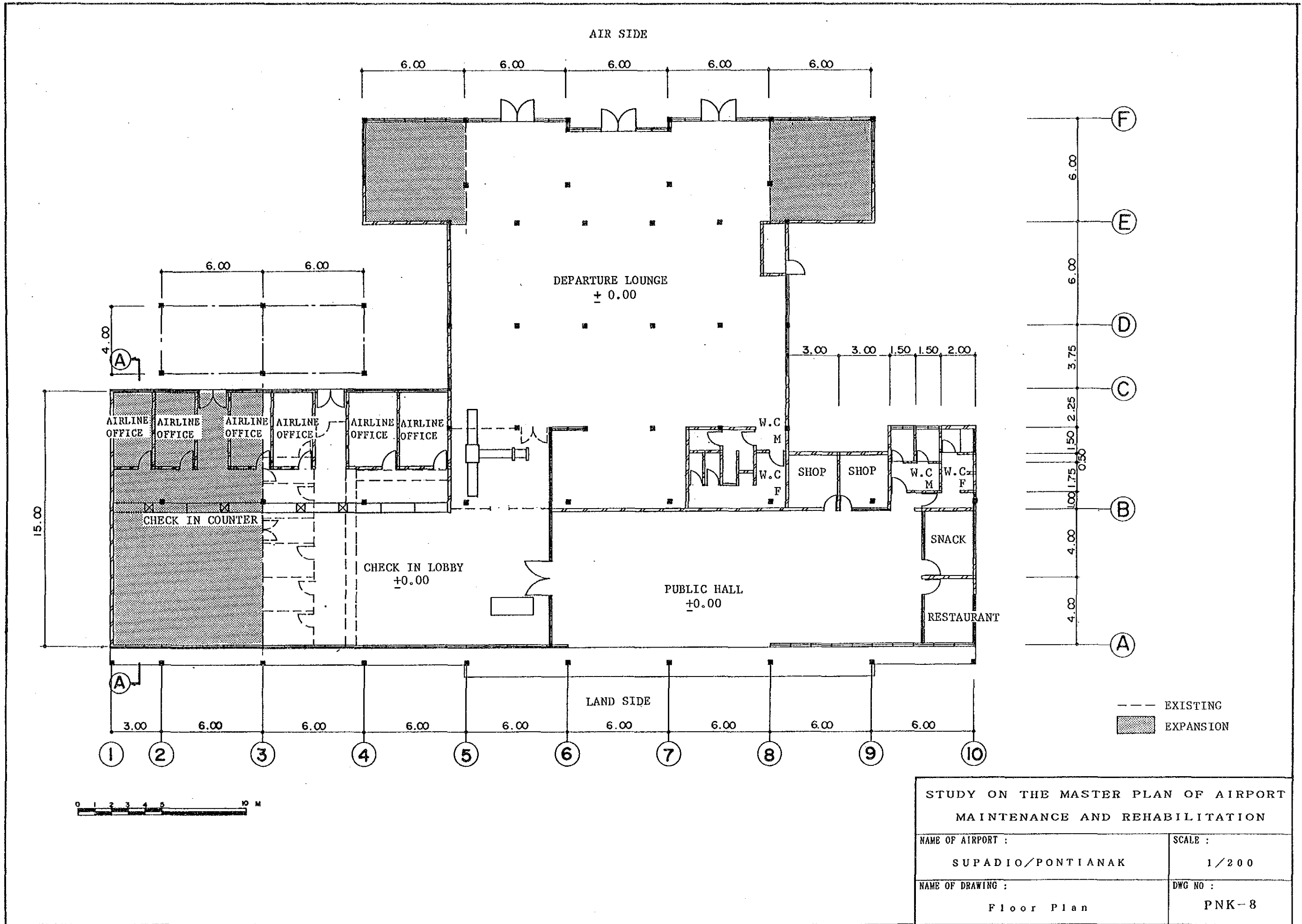

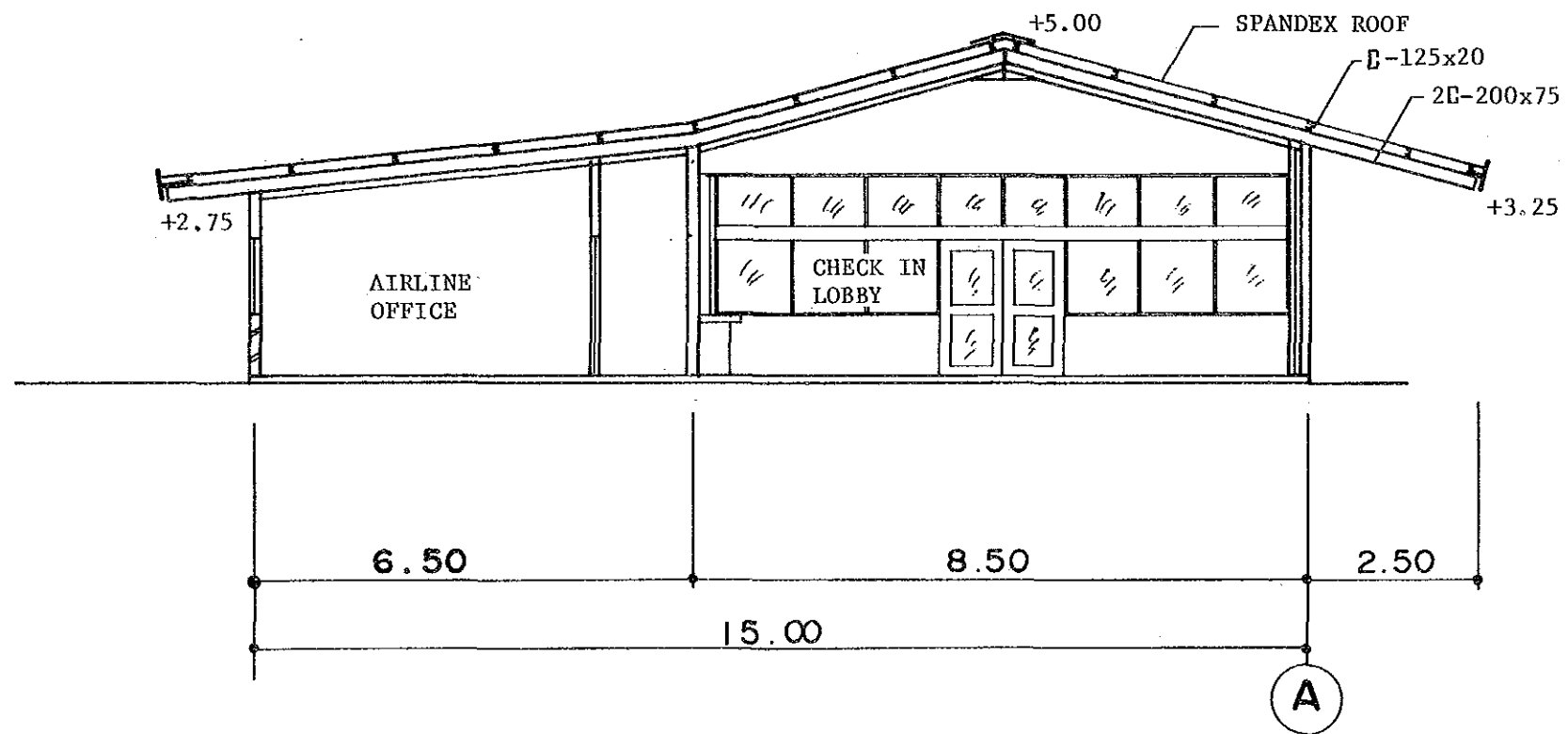

Ⓐ-Ⓐ SECTION

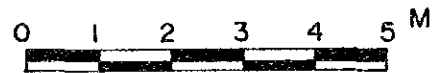

STUDY ON THE MASTER PLAN OF AIRPORT MAINTENANCE AND REHABILITATION	
NAME OF AIRPORT :	SCALE :
SUPADIO/PONTIANAK	1/100
NAME OF DRAWING :	DWG NO :
Section	PNK-9

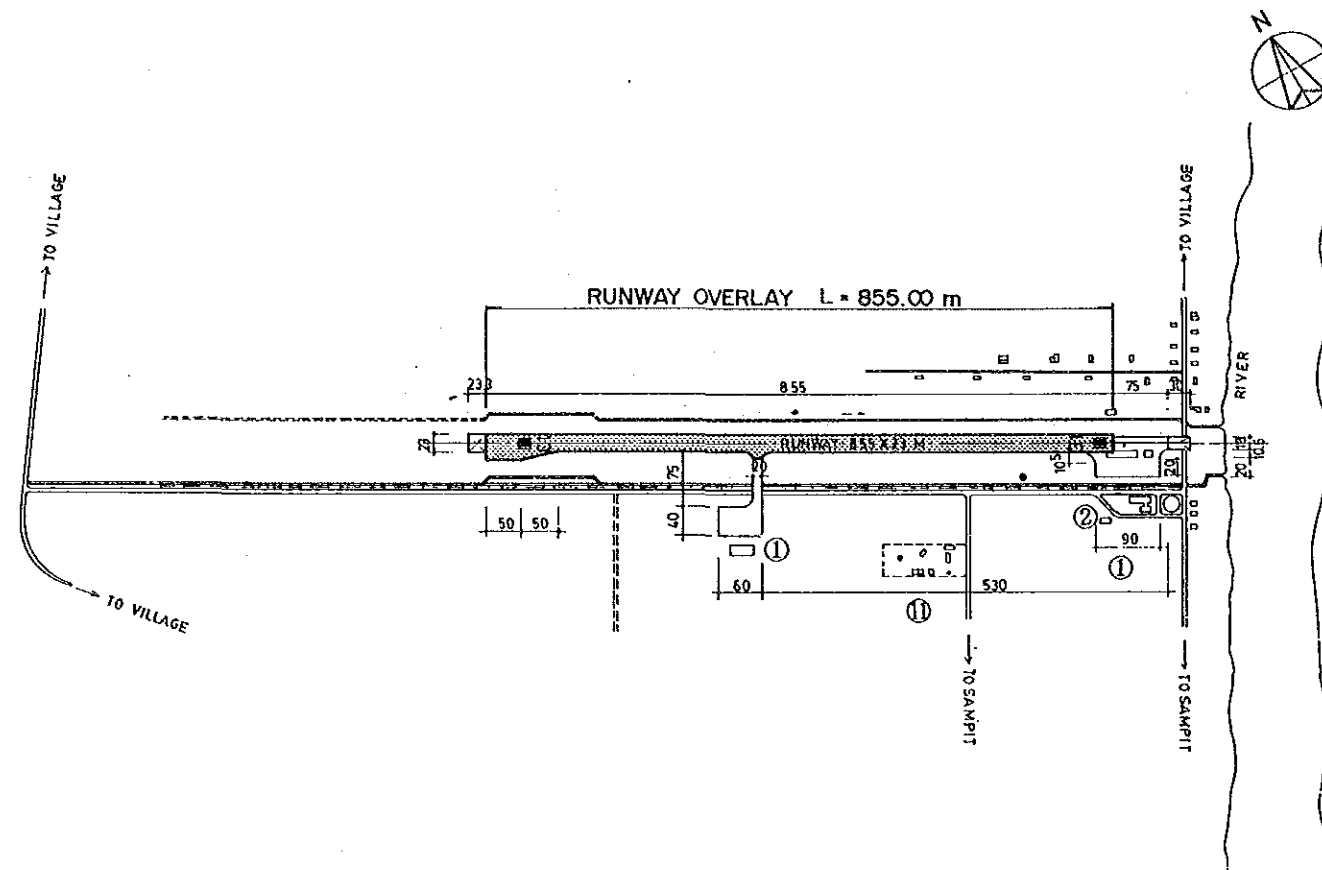

BASIC DATA TABLE			
AIRPORT CLASS	V	RUNWAY DIRECTION	13-31
AIRPORT STATUS	DOMESTIC	INSTRUMENT RUNWAY	
AIRPORT ELEVATION	4.5M	PAVEMENT STRENGTH	
AIRPORT REF. POINT (ARP) COORDINATES	02° 33' S 112° 58' E	NAVIGATIONAL AIDS	NDB
AIRPORT REF. TEMP	30°C	DISTANCE FROM CITY	5KM



MAJOR BUILDINGS					
No.	Name of Building	tick if available	No.	Name of Building	tick if available
1	Passenger Terminal	✓	7	VIP Building	
2	Administration Building	✓	8	Main Power House	
3	Operations Building		9	Fire Station	
4	Control Tower		10	Fuel Farm	
5	Workshop		11	Staff Housing	✓
6	Cargo Terminal Building				

LEGEND	
—x—x—	Fence
====	Ditch

STUDY ON THE MASTER PLAN OF AIRPORT MAINTENANCE AND REHABILITATION	
NAME OF AIRPORT :	SCALE :
HASAN/SAMPIT	1/10,000
NAME OF DRAWING :	DWG NO :
Layout Plan	SMQ-1

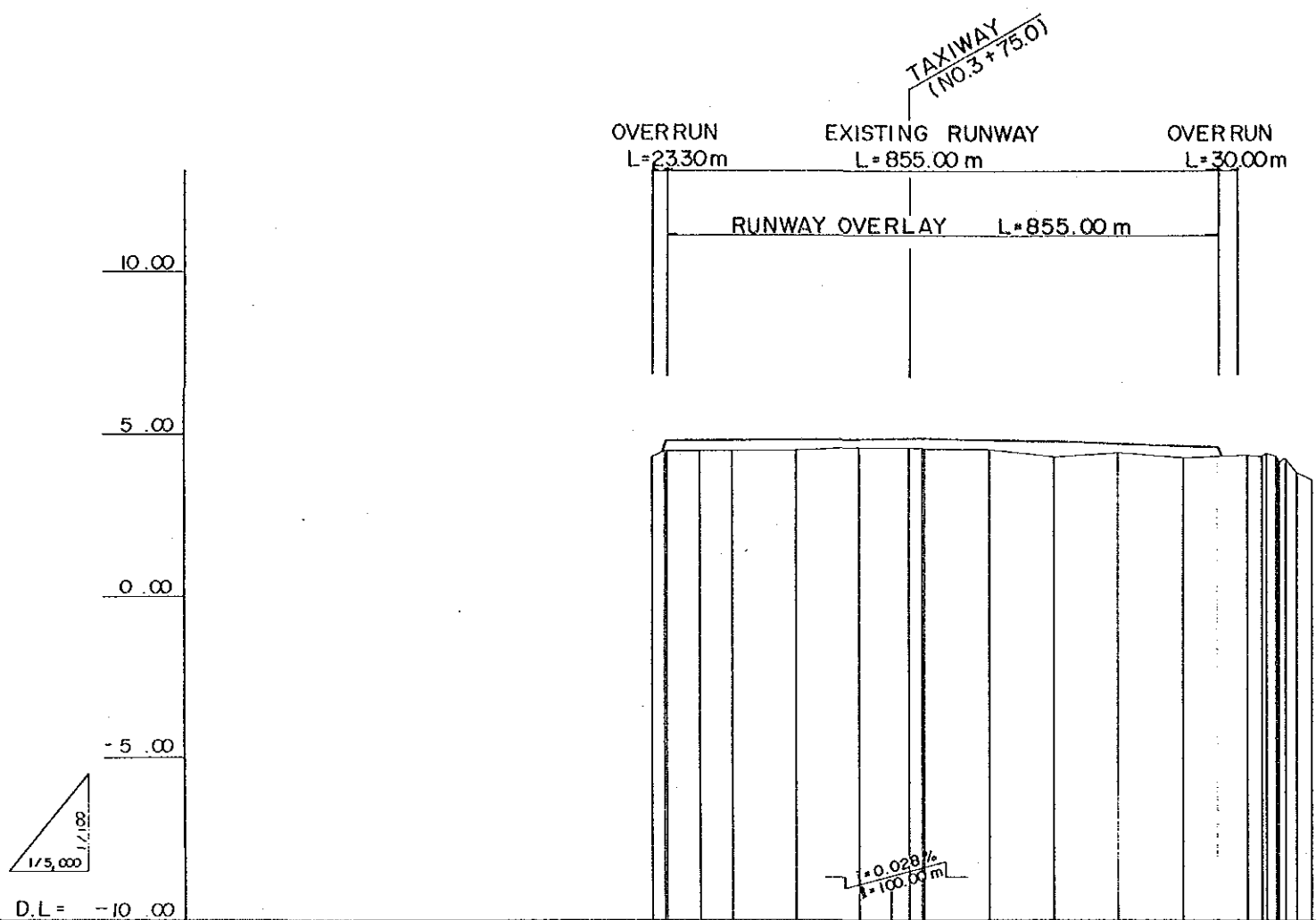

SLOPE	$i = 0.006\%$ $f = 300.00\text{m}$ $i = 0.031\%$ $f = 200.00\text{m}$ $i = 0.082\%$ $f = 255.00\text{m}$									
OVERLAY THICKNESS										
PROPOSED HEIGHT										
GROUND HEIGHT										
ACCUMULATED DISTANCE										
STATION										

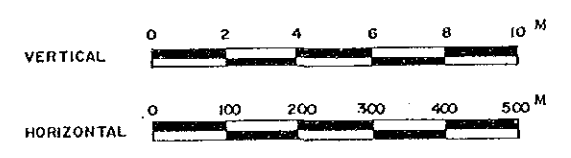

STUDY ON THE MASTER PLAN OF AIRPORT MAINTENANCE AND REHABILITATION	
NAME OF AIRPORT :	SCALE :
HASAN/SAMPIT	V = 1/200 H = 1/10,000
NAME OF DRAWING :	DWG NO :
Runway Profile	SMQ-2

NO. 3

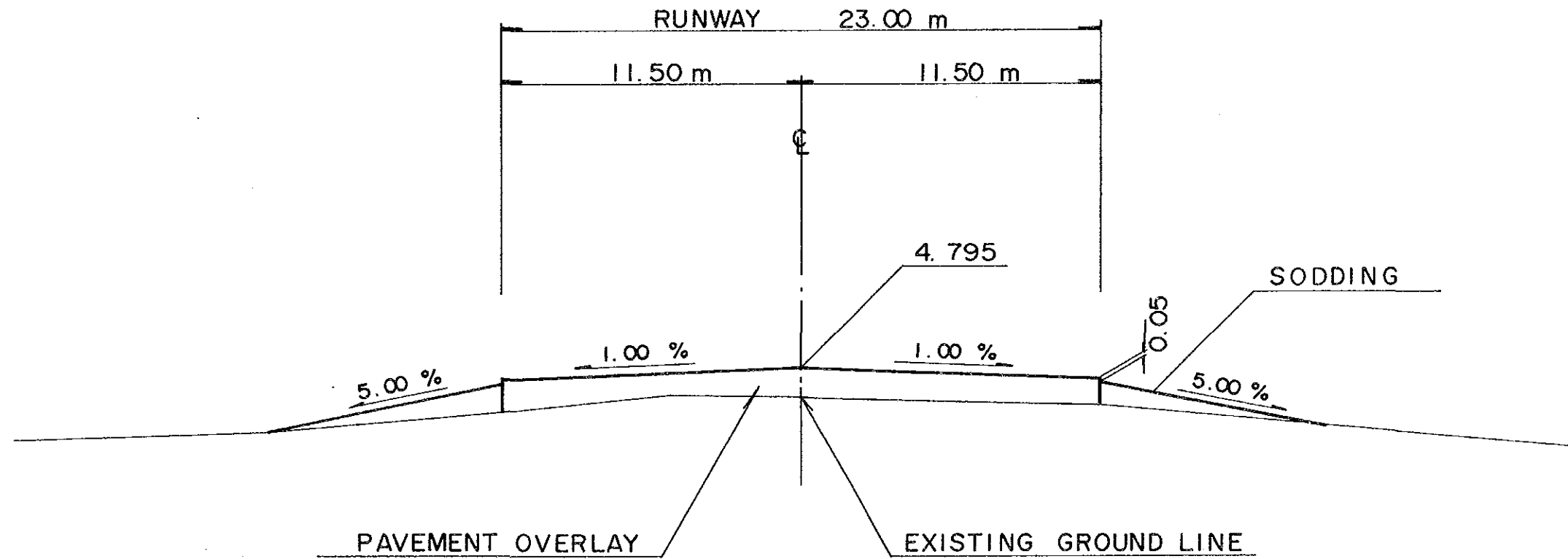

RUNWAY OVERLAY

STUDY ON THE MASTER PLAN OF AIRPORT MAINTENANCE AND REHABILITATION	
NAME OF AIRPORT : HASAN/SAMPIT	SCALE : V=1/50 H=1/200
NAME OF DRAWING : Typical Cross Section	DWG NO : SMQ-3

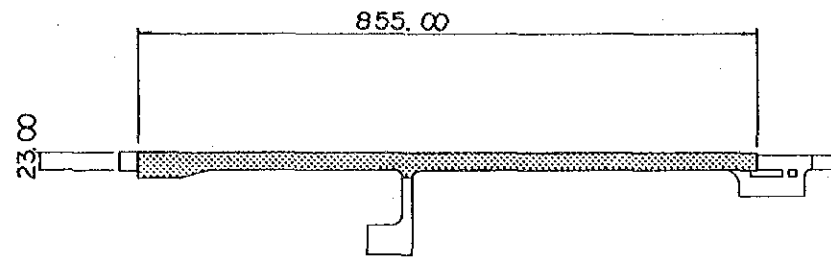

RUNWAY OVERLAY

■ PT-1

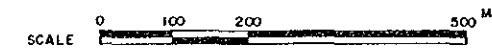
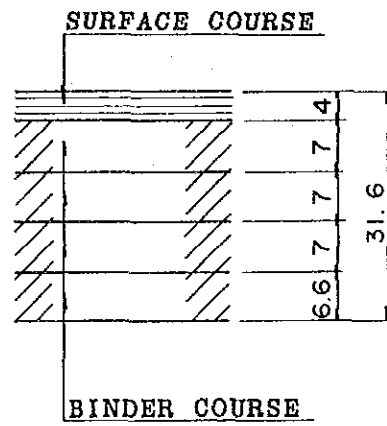

STUDY ON THE MASTER PLAN OF AIRPORT MAINTENANCE AND REHABILITATION	
NAME OF AIRPORT : HASAN/SAMPIT	SCALE : 1/10,000
NAME OF DRAWING : Pavement Plan	DWG NO : SMQ-4

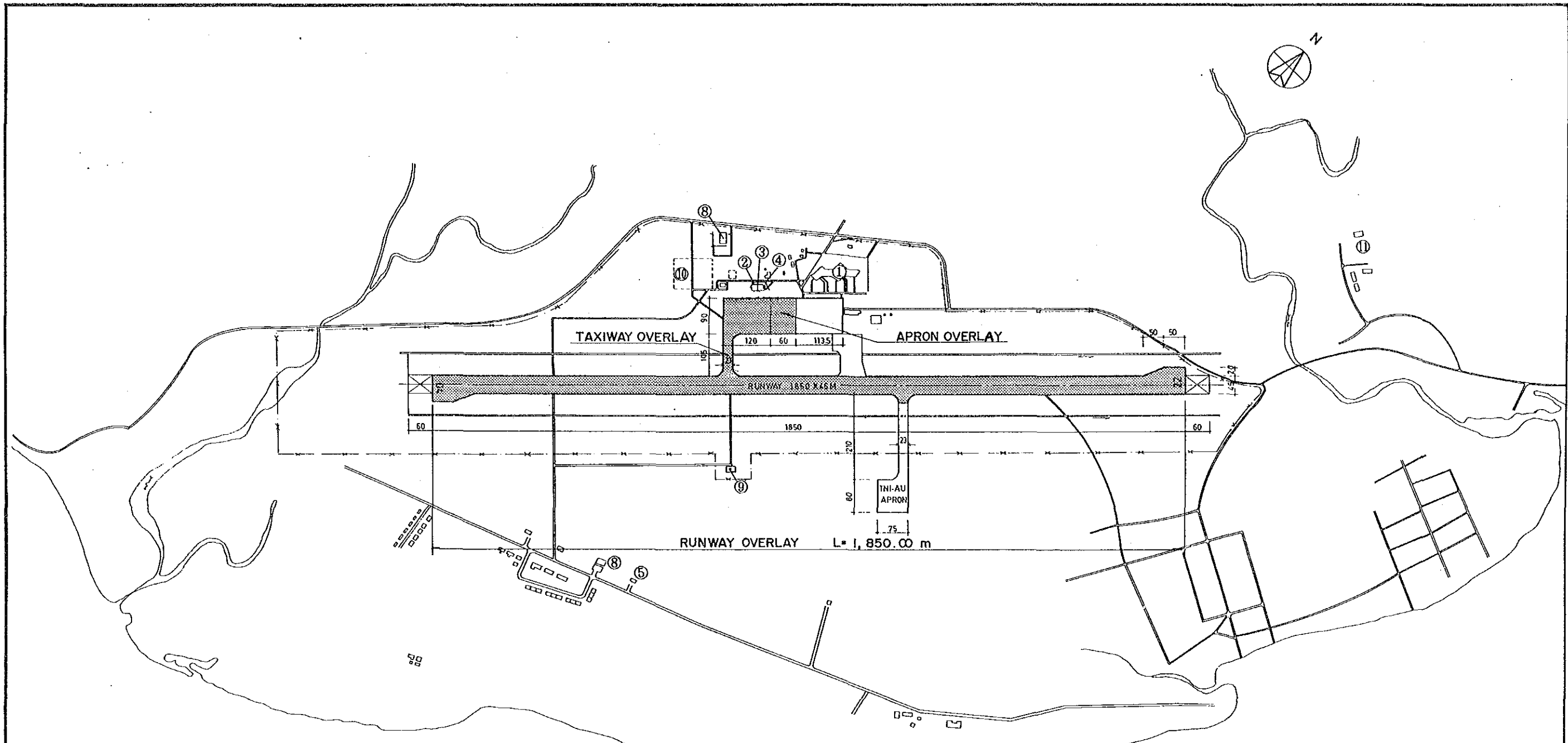

BASIC DATA TABLE			
AIRPORT CLASS	II	RUNWAY DIRECTION	22-04
AIRPORT STATUS	DOMESTIC	INSTRUMENT RUNWAY	
AIRPORT ELEVATION	10M	PAVEMENT STRENGTH	PCN 31 FCZU
AIRPORT REF. POINT (ARP) COORDINATES	128° 05' E 03° 42' S	NAVIGATIONAL AIDS	NDB, VOR/DME ILS
AIRPORT REF. TEMP	28°C	DISTANCE FROM CITY	37KM

MAJOR BUILDINGS					
No.	Name of Building	tick if available	No.	Name of Building	tick if available
1	Passenger Terminal	✓	7	VIP Building	
2	Administration Building	✓	8	Main Power House	✓
3	Operations Building	✓	9	Fire Station	✓
4	Control Tower	✓	10	Fuel Farm	✓
5	Workshop	✓	11	Staff Housing	✓
6	Cargo Terminal Building				

LEGEND	
—x—x—	Fence
====	Ditch

STUDY ON THE MASTER PLAN OF AIRPORT MAINTENANCE AND REHABILITATION	
NAME OF AIRPORT :	SCALE :
PATIMURA/AMBON	1/10,000
NAME OF DRAWING :	DWG NO :
Layout Plan	AMQ-1

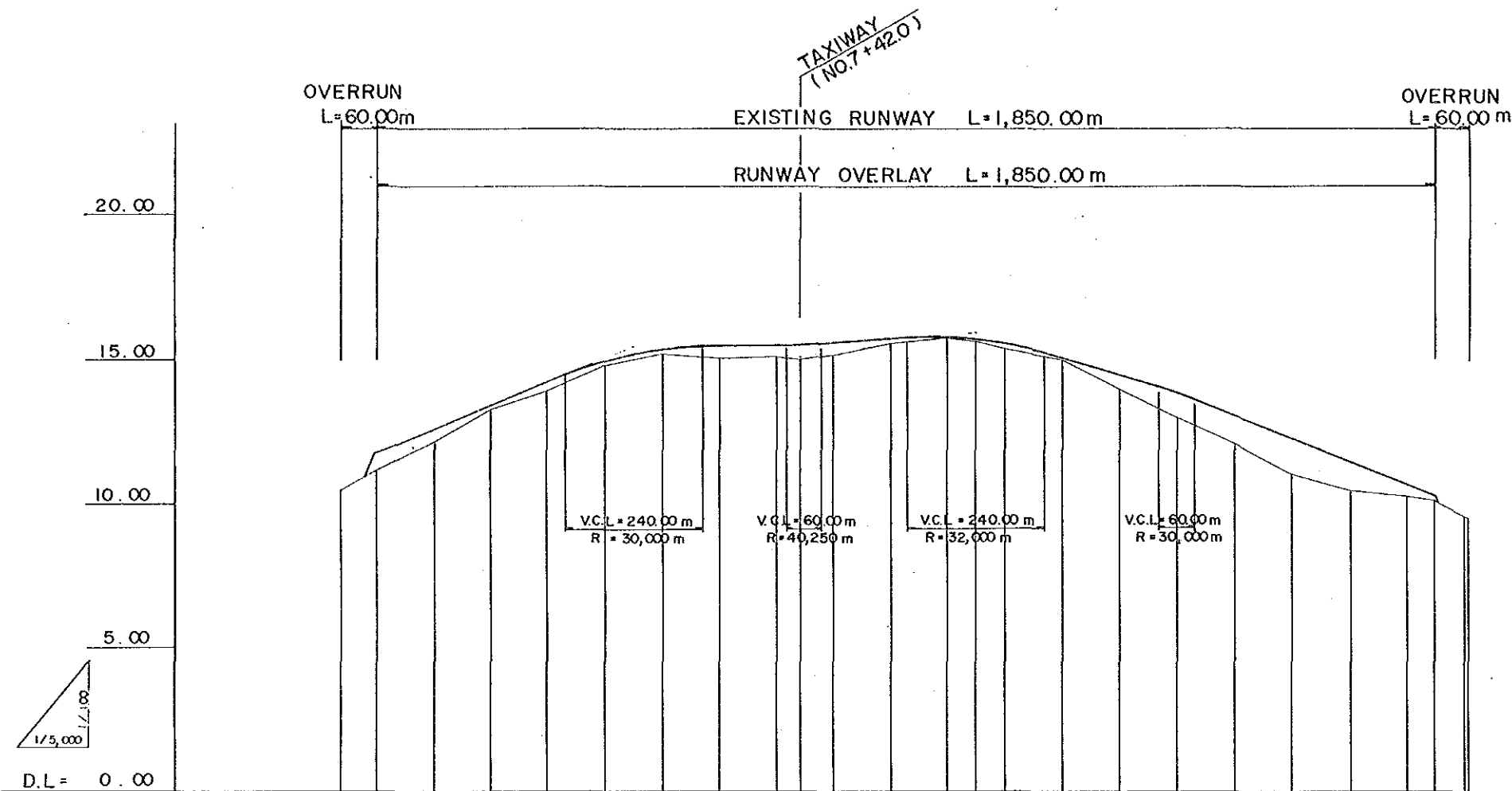

SLOPE																										
OVERLAY THICKNESS			0.642	0.442	0.155	0.320	0.154	0.213	0.189	0.403	0.370	0.437	0.382	0.143	0.001	0.090	0.168	0.030	0.436	0.633	0.928	1.222	0.982	0.413	0.151	
PROPOSED HEIGHT			11.803	12.603	13.403	14.203	14.921	15.163	15.321	15.403	15.403	15.403	15.478	15.484	15.640	15.626	15.475	14.921	14.351	13.736	12.951	12.151	11.351	10.551	10.151	9.466
GROUND HEIGHT	10.422	11.161	12.161	13.248	13.683	14.767	14.950	15.132	15.000	15.033	14.958	14.977	15.096	15.484	15.640	15.536	15.307	14.921	13.915	12.903	12.023	10.929	10.369	10.138	10.000	9.466
ACCUMULATED DISTANCE	60.00	0.00	100.00	200.00	300.00	400.00	450.00	500.00	600.00	700.00	742.00	750.00	800.00	900.00	1000.00	1050.00	1100.00	1200.00	1300.00	1400.00	1500.00	1600.00	1700.00	1800.00	1850.00	1900.00
STATION	-50.0	NO.0	NO.1	NO.2	NO.3	NO.4	+50.0	NO.5	NO.6	NO.7	+42.0	+50.0	NO.8	NO.9	NO.10	+50.0	NO.11	NO.12	NO.13	NO.14	NO.15	NO.16	NO.17	NO.18	50.0	NO.19

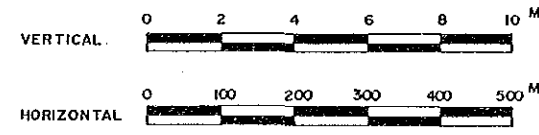

STUDY ON THE MASTER PLAN OF AIRPORT MAINTENANCE AND REHABILITATION	
NAME OF AIRPORT : PATIMURA/AMBON	SCALE : V=1/200 H=1/10,000
NAME OF DRAWING : Runway Profile	DWG NO : AMQ-2

NO.7+42

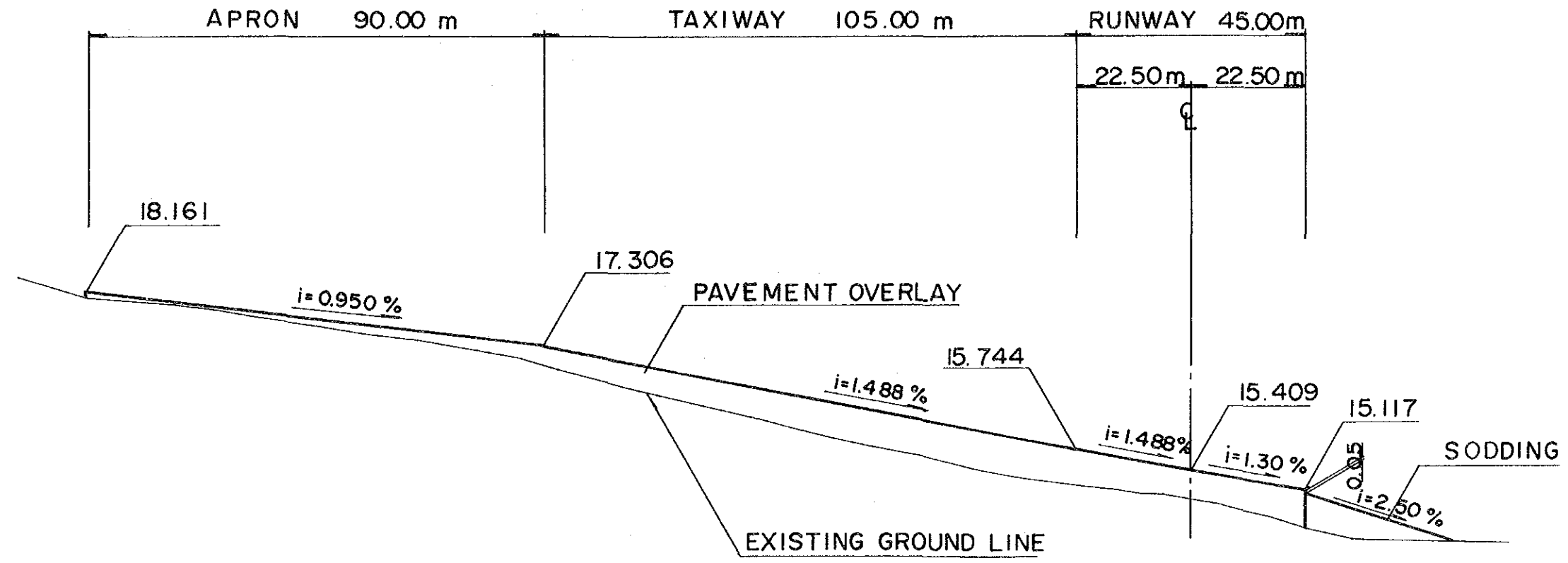

RUNWAY TAXIWAY AND APRON OVERLAY

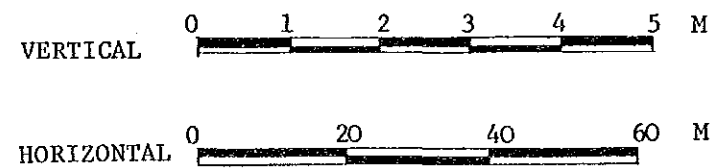

STUDY ON THE MASTER PLAN OF AIRPORT MAINTENANCE AND REHABILITATION	
NAME OF AIRPORT : PATIMURA/AMBON	SCALE : V=1/80 H=1/1000
NAME OF DRAWING : Typical Cross Section	DWG NO : AMQ-3

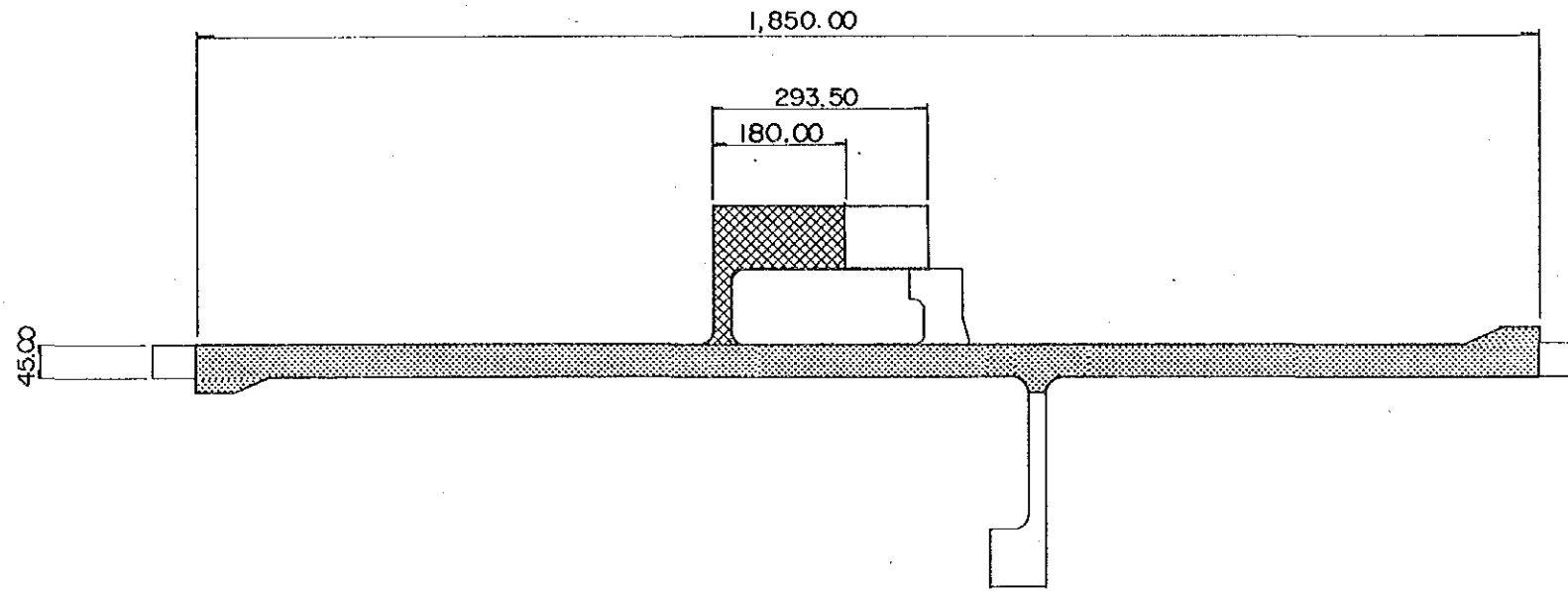

RUNWAY OVERLAY

TAXIWAY AND APRON OVERLAY

PT-1

PT-2

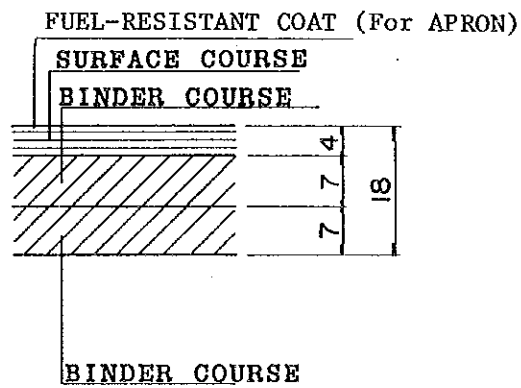
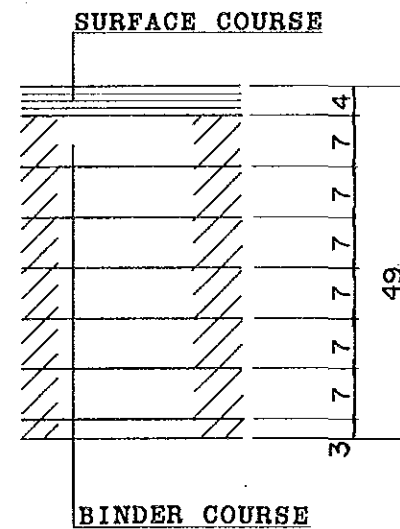

STUDY ON THE MASTER PLAN OF AIRPORT
MAINTENANCE AND REHABILITATION

NAME OF AIRPORT :	SCALE :
PATIMURA/AMBON	1/10,000
NAME OF DRAWING :	DWG NO :
Pavement Plan	AMQ-4

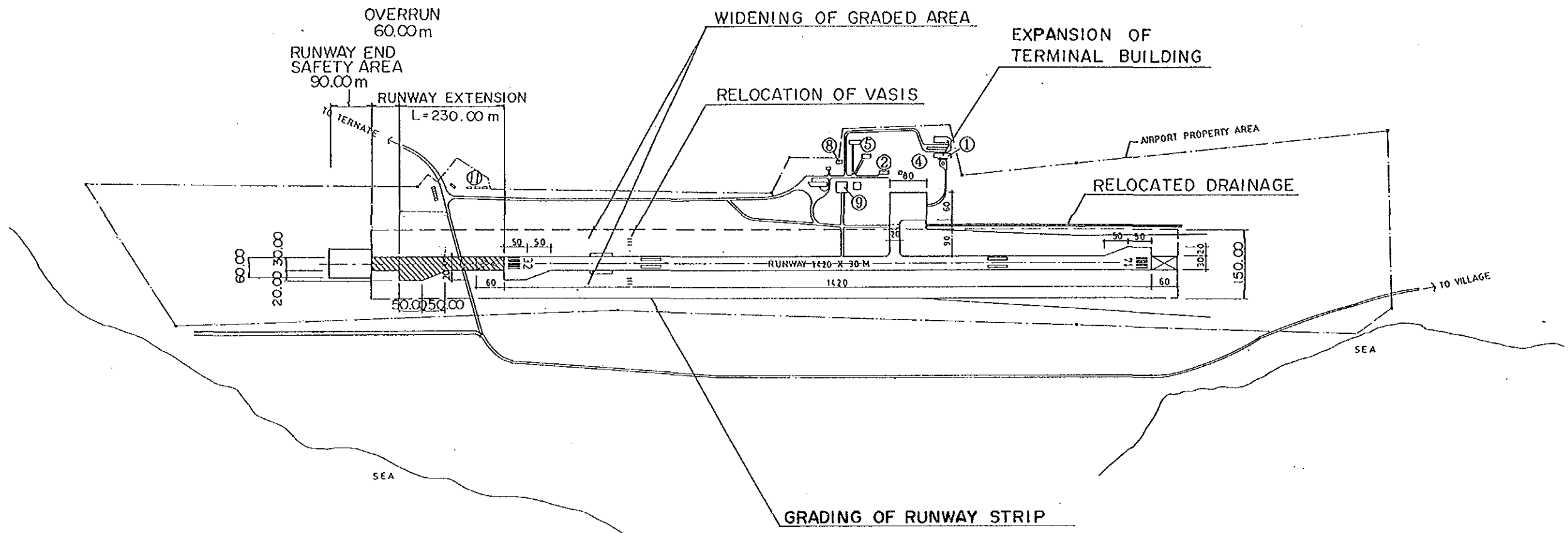

BASIC DATA TABLE			
AIRPORT CLASS	III	RUNWAY DIRECTION	14-32
AIRPORT STATUS	DOMESTIC	INSTRUMENT RUNWAY	
AIRPORT ELEVATION	15M	PAVEMENT STRENGTH	PCN 12 FCZU
AIRPORT REF. POINT (ARP) COORDINATES	00° 50' S 127° 23' E	NAVIGATIONAL AIDS	NDB, VOR
AIRPORT REF. TEMP	30°C	DISTANCE FROM CITY	4KM

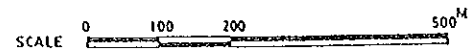

MAJOR BUILDINGS					
No.	Name of Building	tick if available	No.	Name of Building	tick if available
1	Passenger Terminal	✓	7	VIP Building	
2	Administration Building	✓	8	Main Power House	✓
3	Operations Building		9	Fire Station	✓
4	Control Tower	✓	10	Fuel Farm	
5	Workshop	✓	11	Staff Housing	✓
6	Cargo Terminal Building				

LEGEND	
—x—x—	Fence
====	Ditch

STUDY ON THE MASTER PLAN OF AIRPORT MAINTENANCE AND REHABILITATION	
NAME OF AIRPORT :	SCALE :
BABULLAH/TERNATE	1/10,000
NAME OF DRAWING :	DWG NO :
Layout Plan	TTE-1

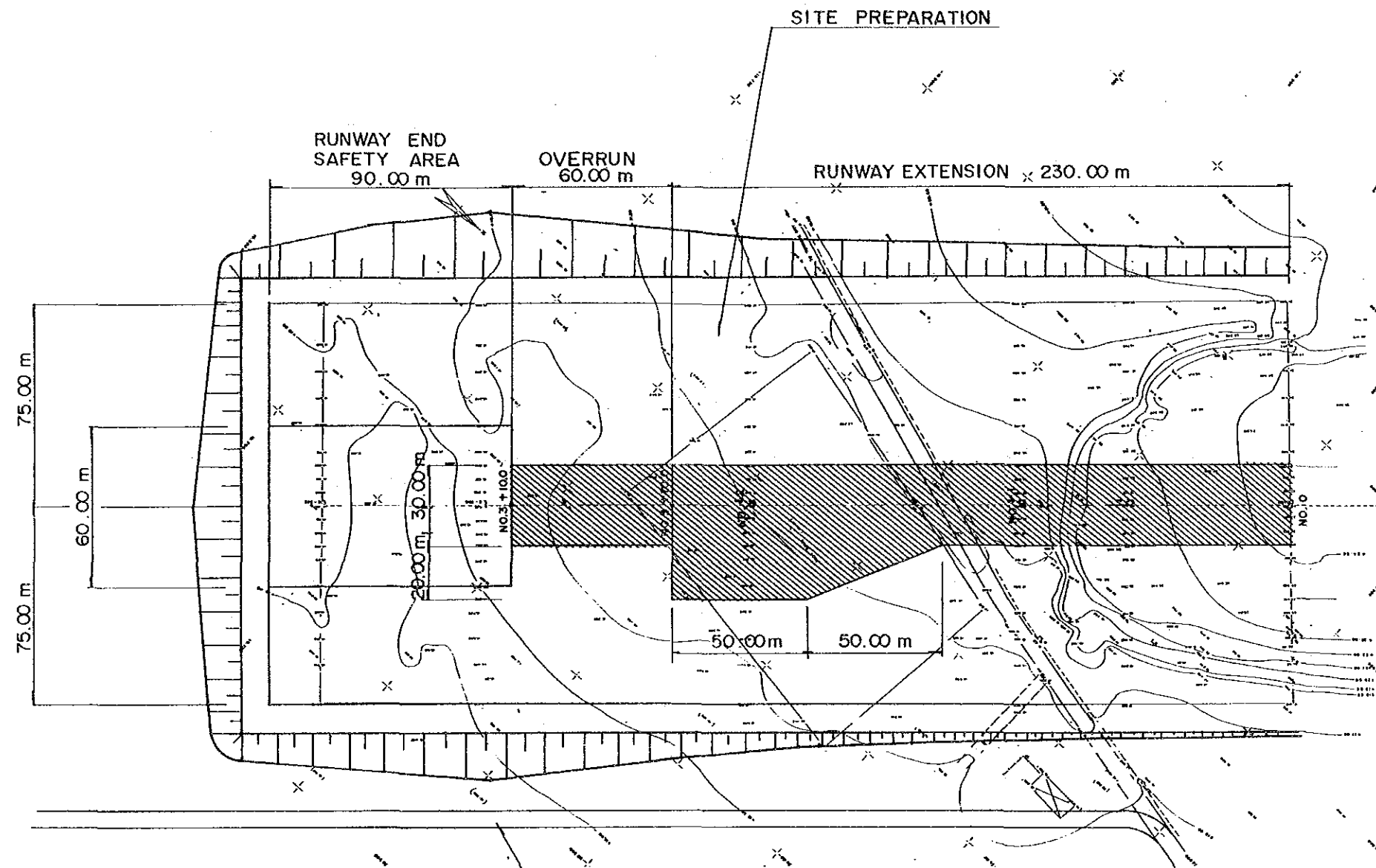

SCALE 0 20 40 60 80 100 M

RELOCATION OF PUBLIC ROAD
UNDER CONSTRUCTION BY OTHERS

STUDY ON THE MASTER PLAN OF AIRPORT MAINTENANCE AND REHABILITATION	
NAME OF AIRPORT :	SCALE :
BABULLAH/TERNATE	1/2,000
NAME OF DRAWING :	DWG NO :
Detailed Plan	TTE-2

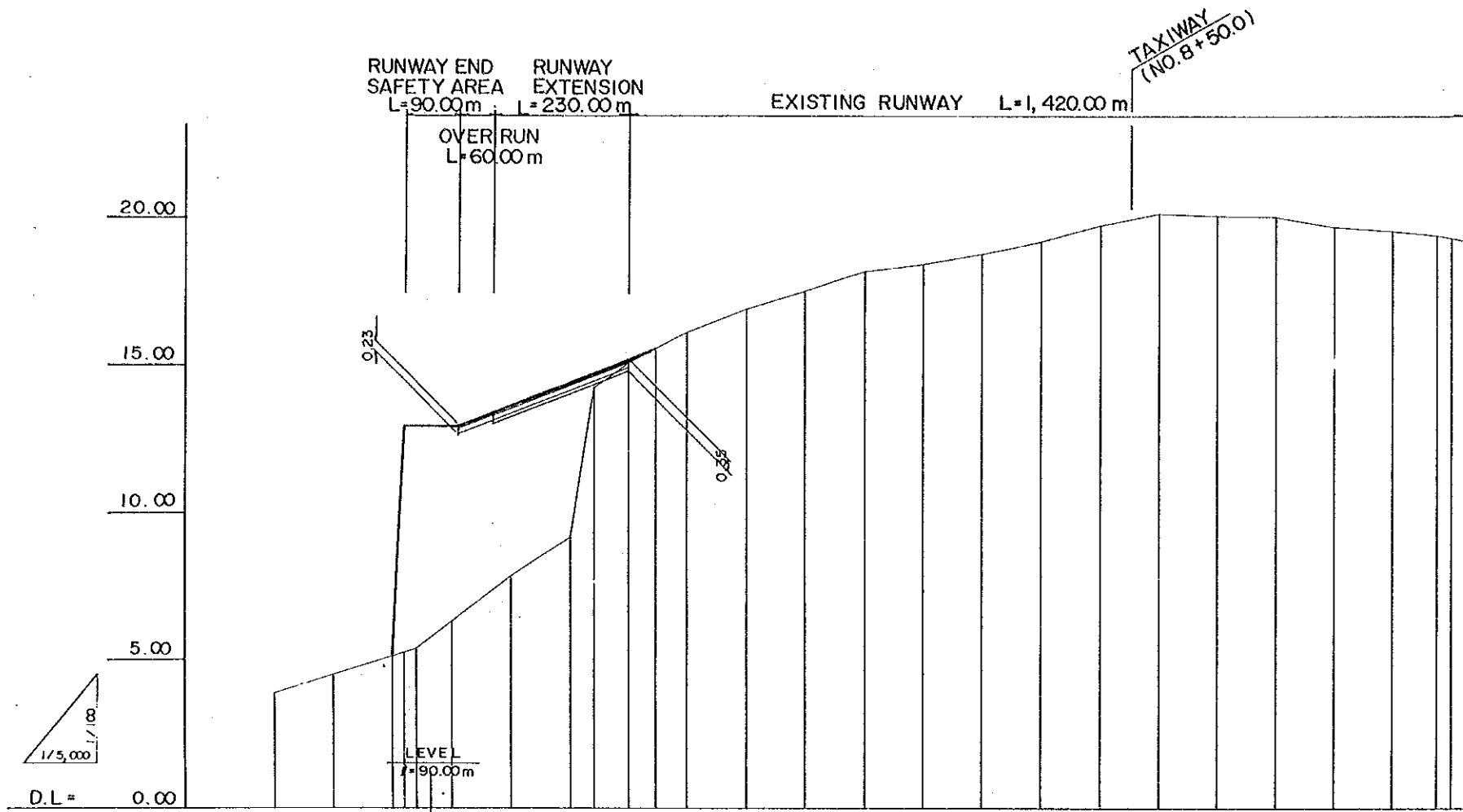

SLOPE															
CUT OR BANK															
PROPOSED HEIGHT															
GROUND HEIGHT															
ACCUMULATED DISTANCE															
STATION															

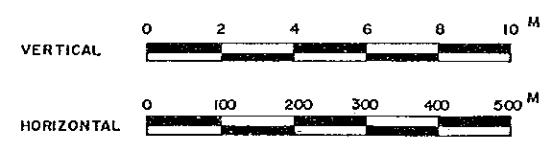

STUDY ON THE MASTER PLAN OF AIRPORT MAINTENANCE AND REHABILITATION	
NAME OF AIRPORT :	SCALE :
BABULLAH/TERNATE	V = 1/200 H = 1/10,000
NAME OF DRAWING :	DWG NO :
Runway Profile	TTE-3

NO.- 2

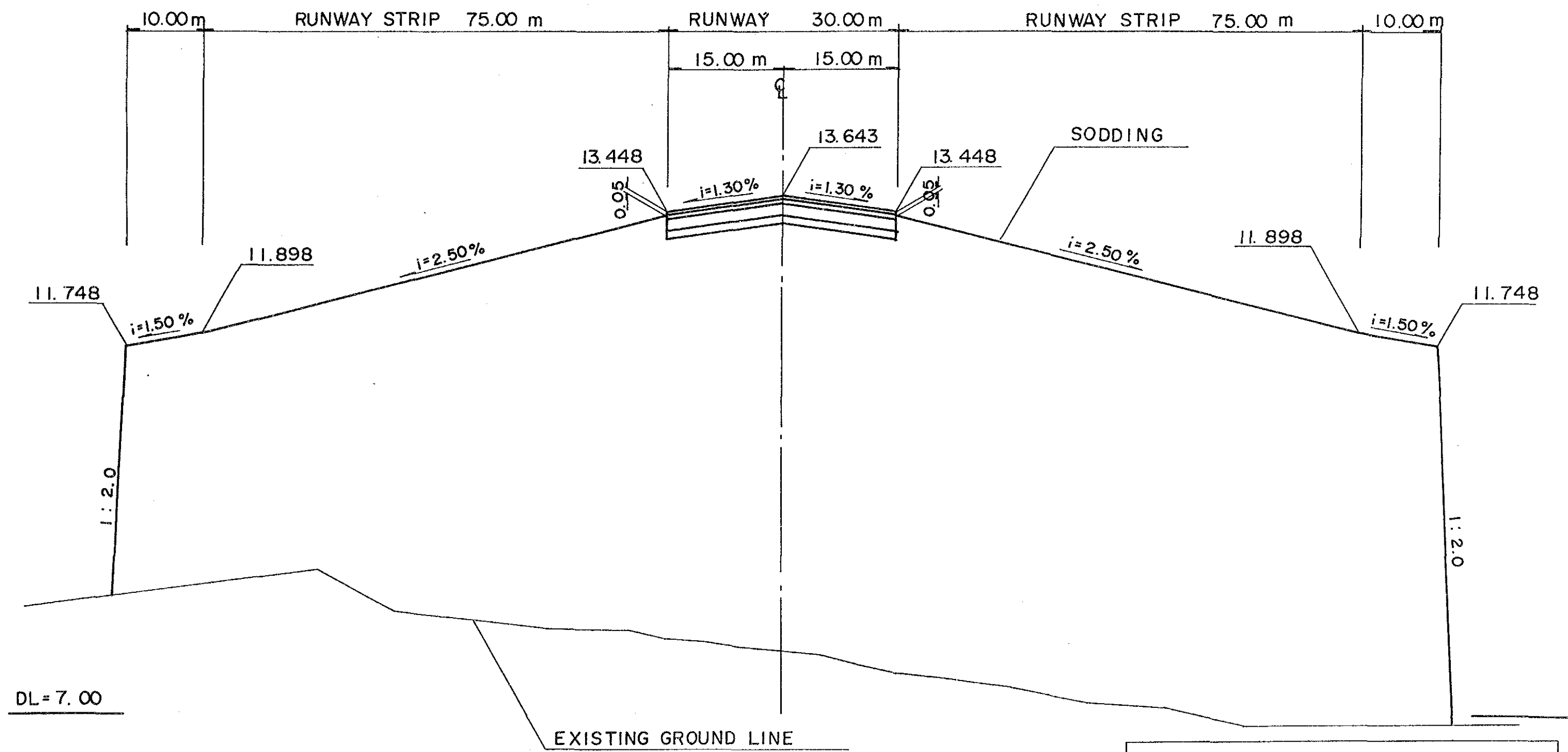

RUNWAY EXTENSION

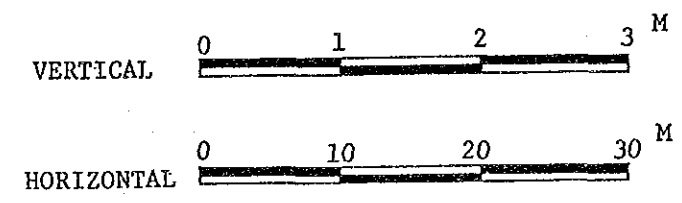

STUDY ON THE MASTER PLAN OF AIRPORT MAINTENANCE AND REHABILITATION	
NAME OF AIRPORT : BABULLAH/TERNATE	SCALE : V = 1/50 H = 1/500
NAME OF DRAWING : Typical Cross Section	DWG NO : TTE-4

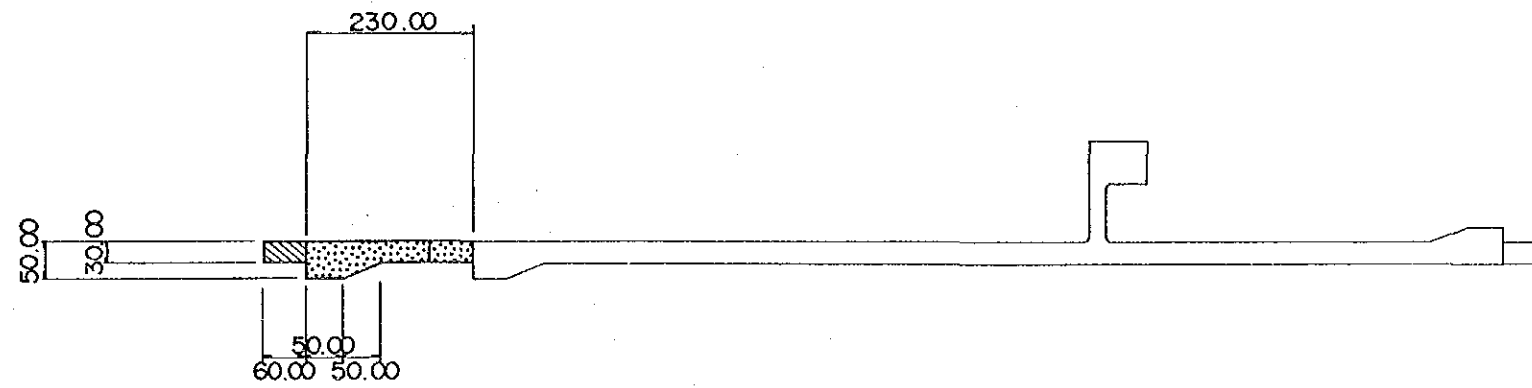

RUNWAY EXTENSION

OVERRUN

PT-1

PT-2

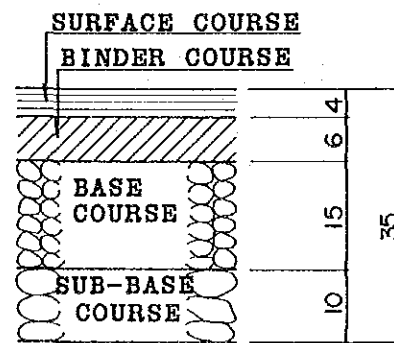

SUBGRADE

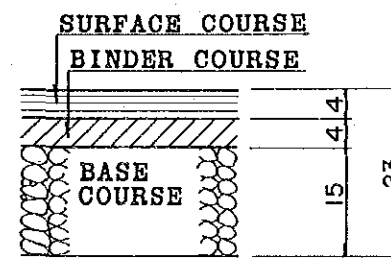

SUBGRADE

STUDY ON THE MASTER PLAN OF AIRPORT MAINTENANCE AND REHABILITATION	
NAME OF AIRPORT :	SCALE :
BABULLAH/TERNATE	1/10,000
NAME OF DRAWING :	DWG NO :
Pavement Plan	TTE-5

AIRSIDE

APRON

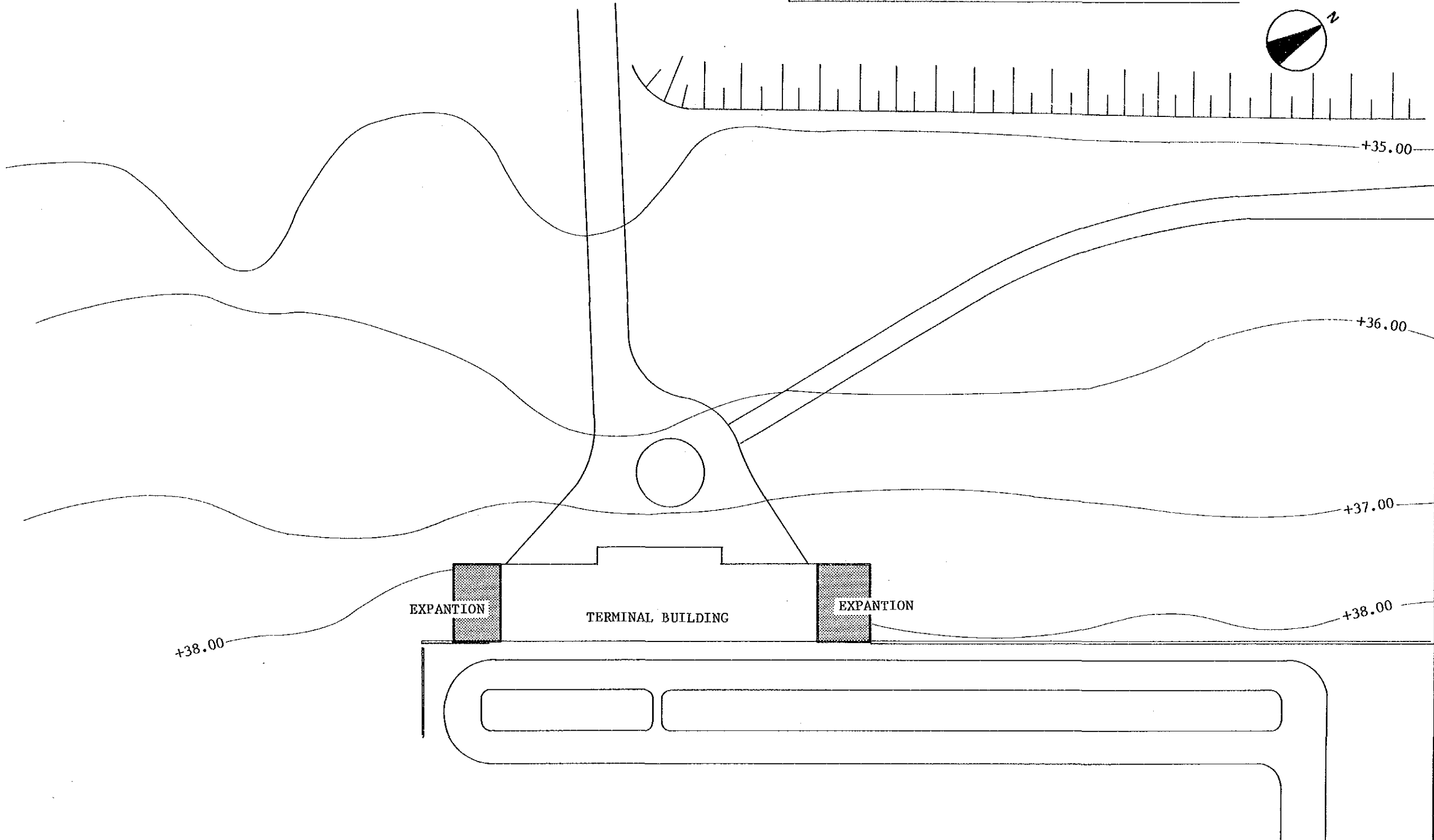

+38.00

+35.00

+36.00

+37.00

+38.00

EXPANTION

TERMINAL BUILDING

EXPANTION

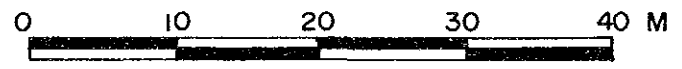

STUDY ON THE MASTER PLAN OF AIRPORT
MAINTENANCE AND REHABILITATION

NAME OF AIRPORT :	SCALE :
BABULLAH/TERNATE	1/500
NAME OF DRAWING :	DWG NO :
Terminal Area Layout Plan	TTE-6

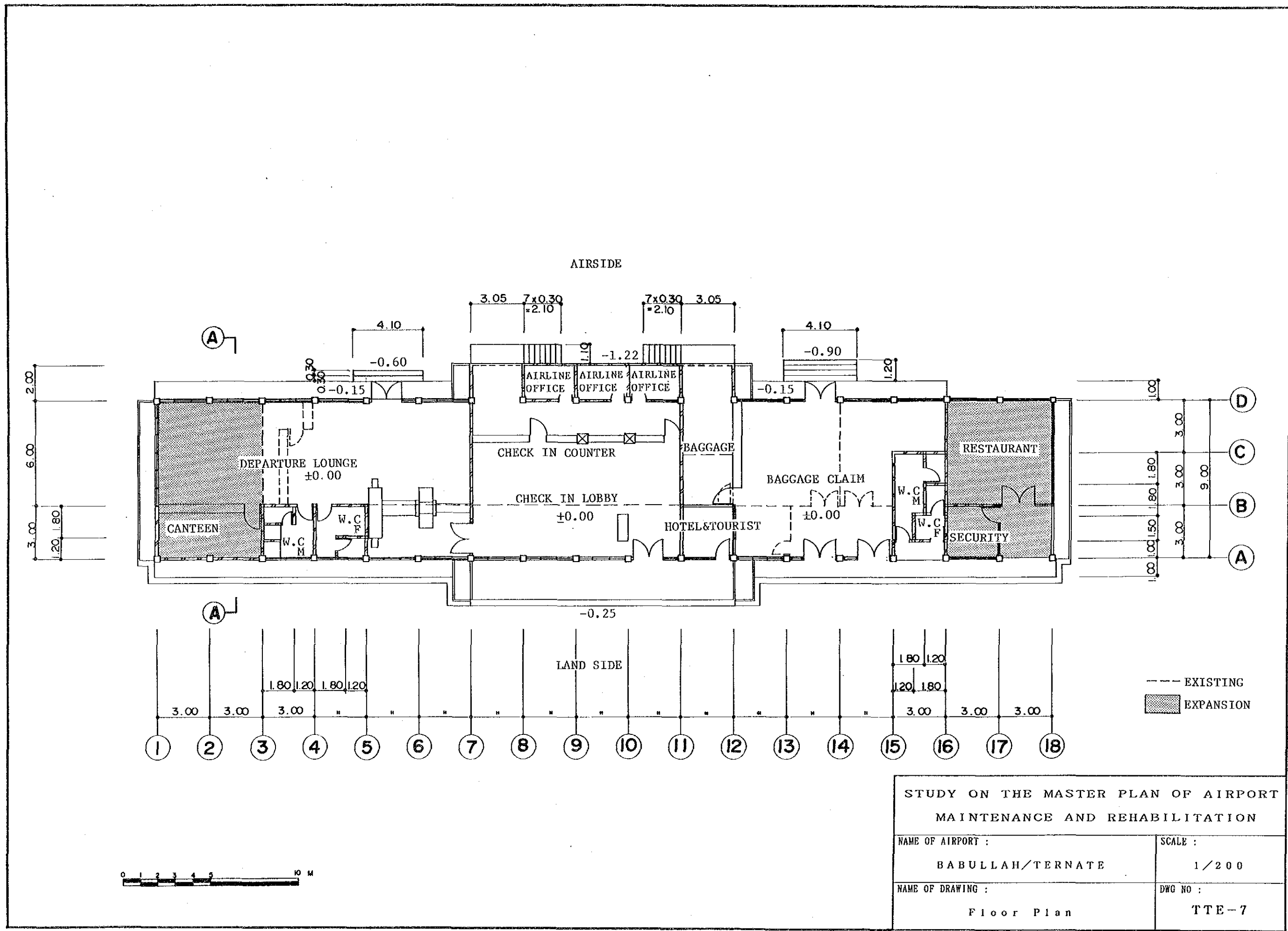

STUDY ON THE MASTER PLAN OF AIRPORT MAINTENANCE AND REHABILITATION	
NAME OF AIRPORT :	SCALE :
BABULLAH/TERNATE	1/200
NAME OF DRAWING :	DWG NO :
Floor Plan	TTE-7

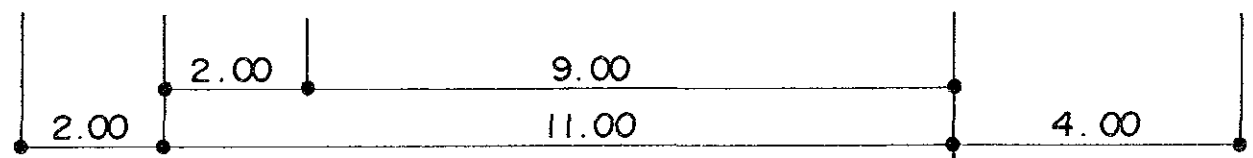
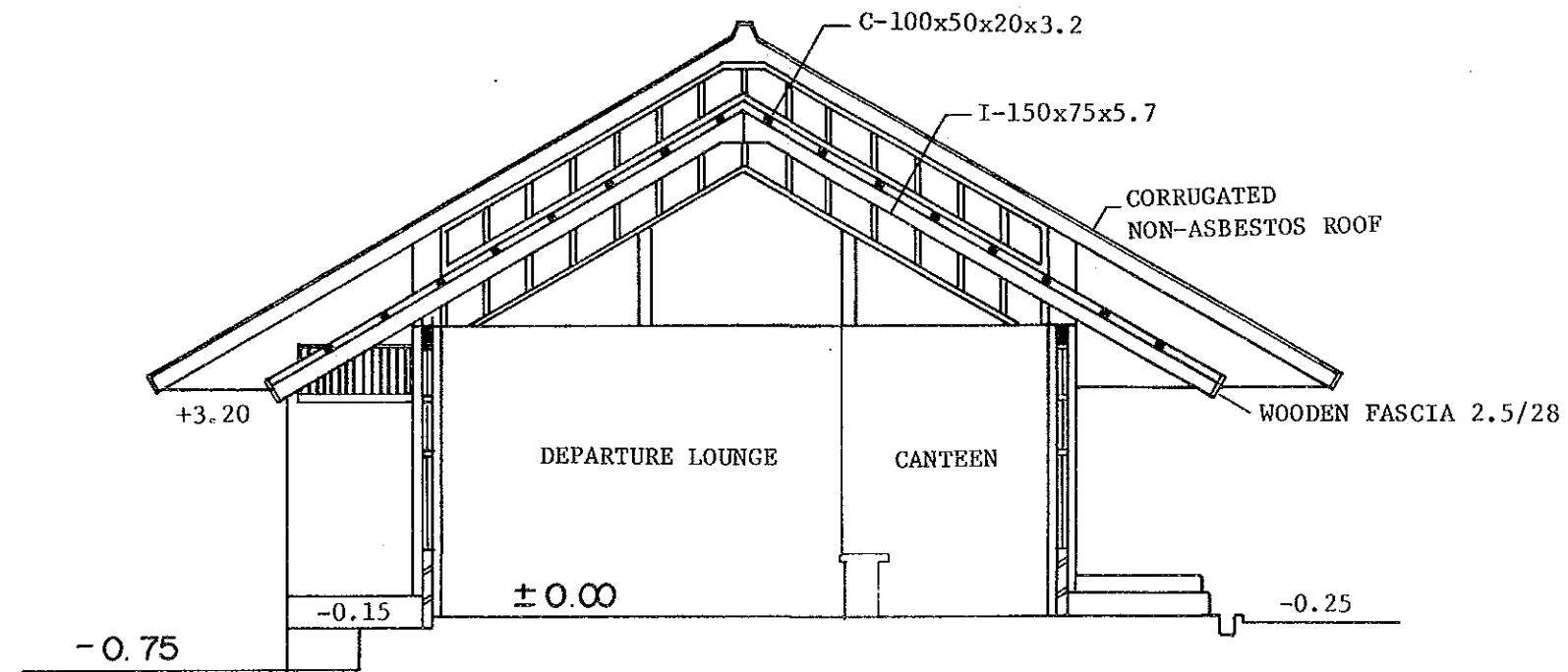

Ⓐ-Ⓐ SECTION

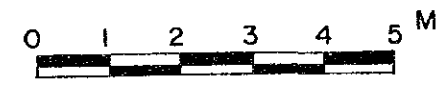

STUDY ON THE MASTER PLAN OF AIRPORT MAINTENANCE AND REHABILITATION	
NAME OF AIRPORT :	SCALE :
BABULLAH/TERNATE	1/100
NAME OF DRAWING :	DWG NO :
Section	TTE-8

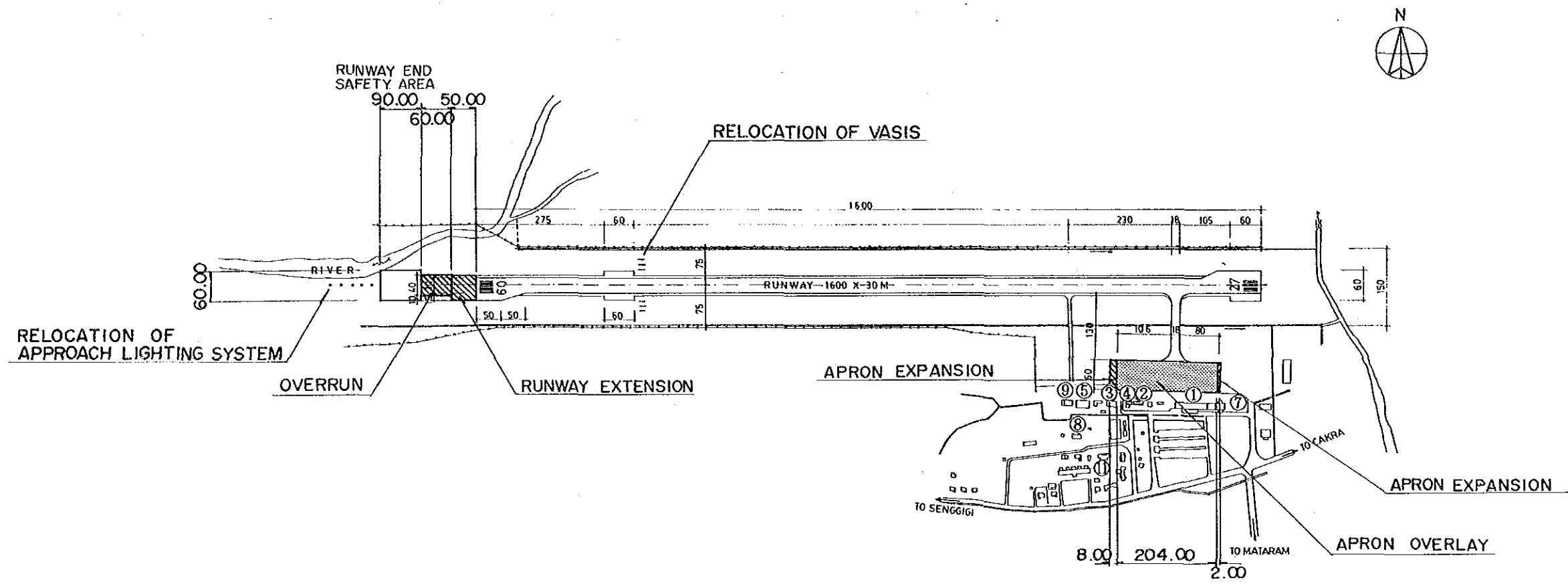

BASIC DATA TABLE

AIRPORT CLASS	III	RUNWAY DIRECTION	09-27
AIRPORT STATUS	DOMESTIC	INSTRUMENT RUNWAY	
AIRPORT ELEVATION	15.40M	PAVEMENT STRENGTH	PCN 20 FCYU
AIRPORT REF. POINT (ARP) COORDINATES	08° 32' S 116° 04' E	NAVIGATIONAL AIDS	NDB, VOR
AIRPORT REF. TEMP	26.9°C	DISTANCE FROM CITY	1KM

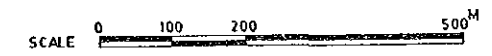

MAJOR BUILDINGS

No.	Name of Building	tick if available	No.	Name of Building	tick if available
1	Passenger Terminal	✓	7	VIP Building	✓
2	Administration Building	✓	8	Main Power House	✓
3	Operations Building	✓	9	Fire Station	✓
4	Control Tower	✓	10	Fuel Farm	
5	Workshop	✓	11	Staff Housing	
6	Cargo Terminal Building				

LEGEND

—x—x—	Fence
====	Ditch

STUDY ON THE MASTER PLAN OF AIRPORT MAINTENANCE AND REHABILITATION

NAME OF AIRPORT : SELAPARANG/MATARAM	SCALE : 1/10,000
NAME OF DRAWING : Layout Plan	DWG NO : AMI-1

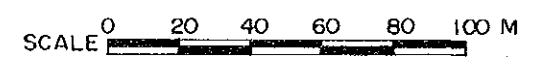
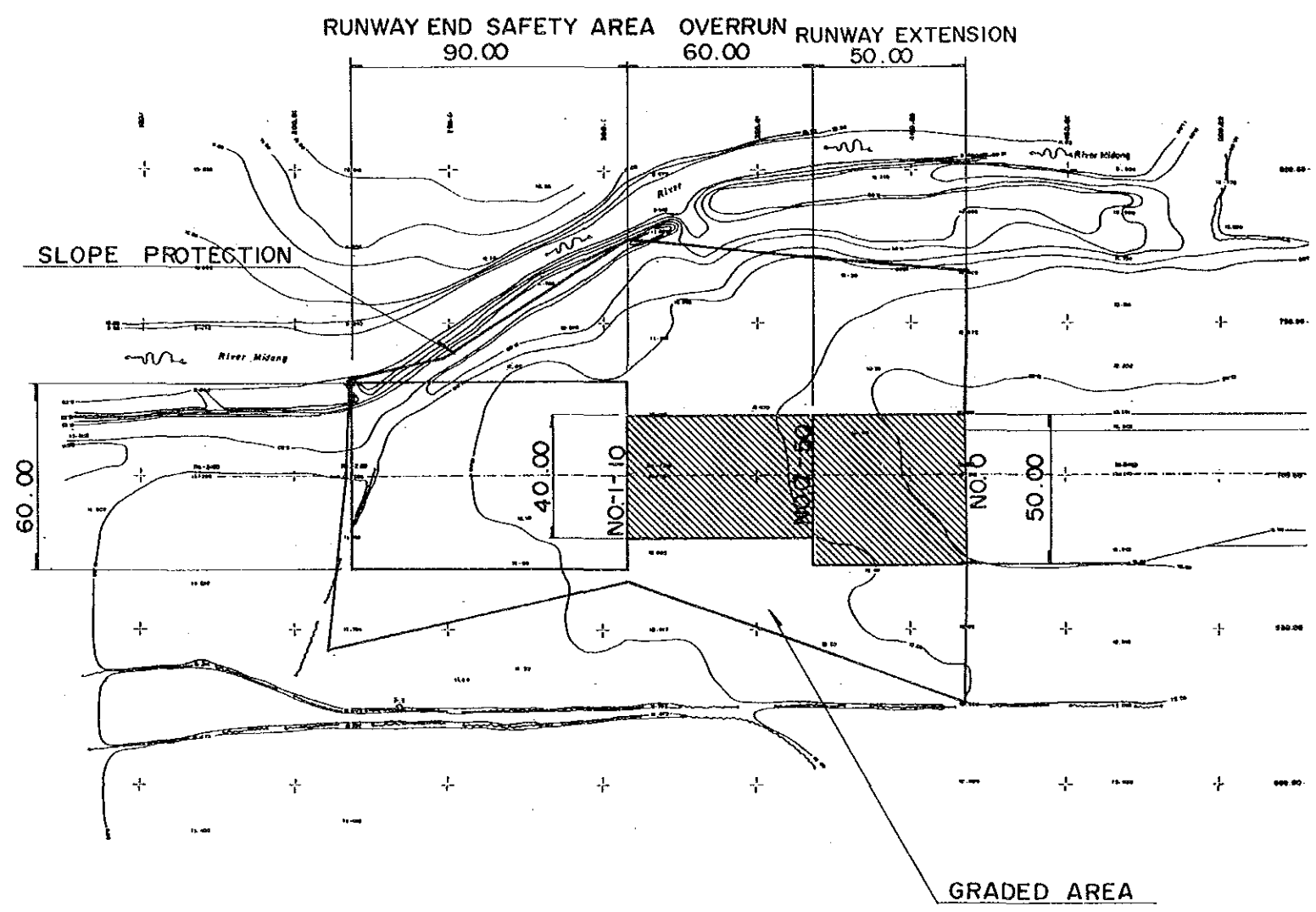
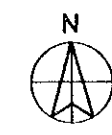

STUDY ON THE MASTER PLAN OF AIRPORT MAINTENANCE AND REHABILITATION	
NAME OF AIRPORT : SELAPARANG/MATARAM	SCALE : 1/2,000
NAME OF DRAWING : Detailed Plan	DWG NO : AMI-2

NO. 14

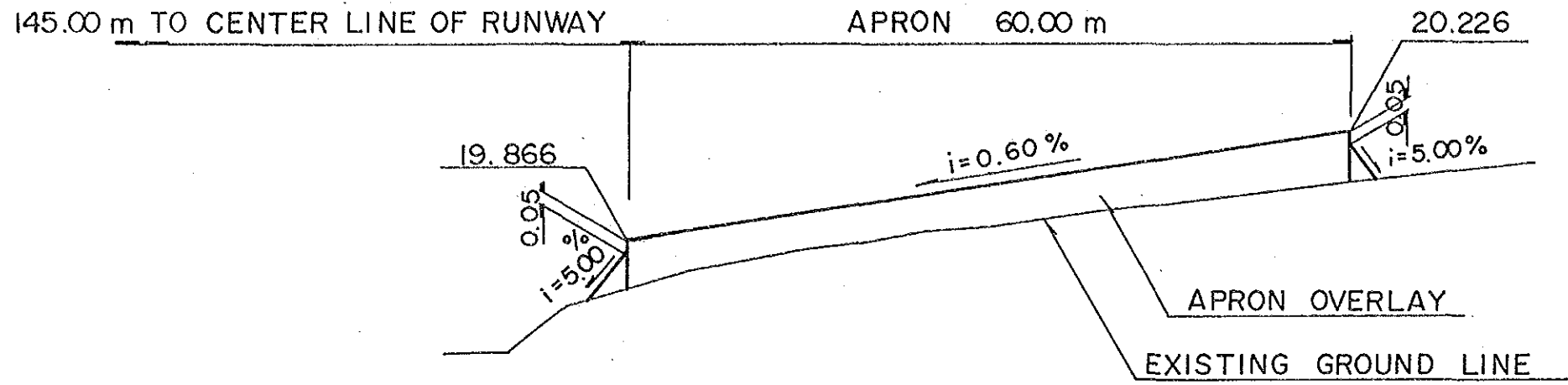

APRON OVERLAY

DL = 19.00

NO. 0-25

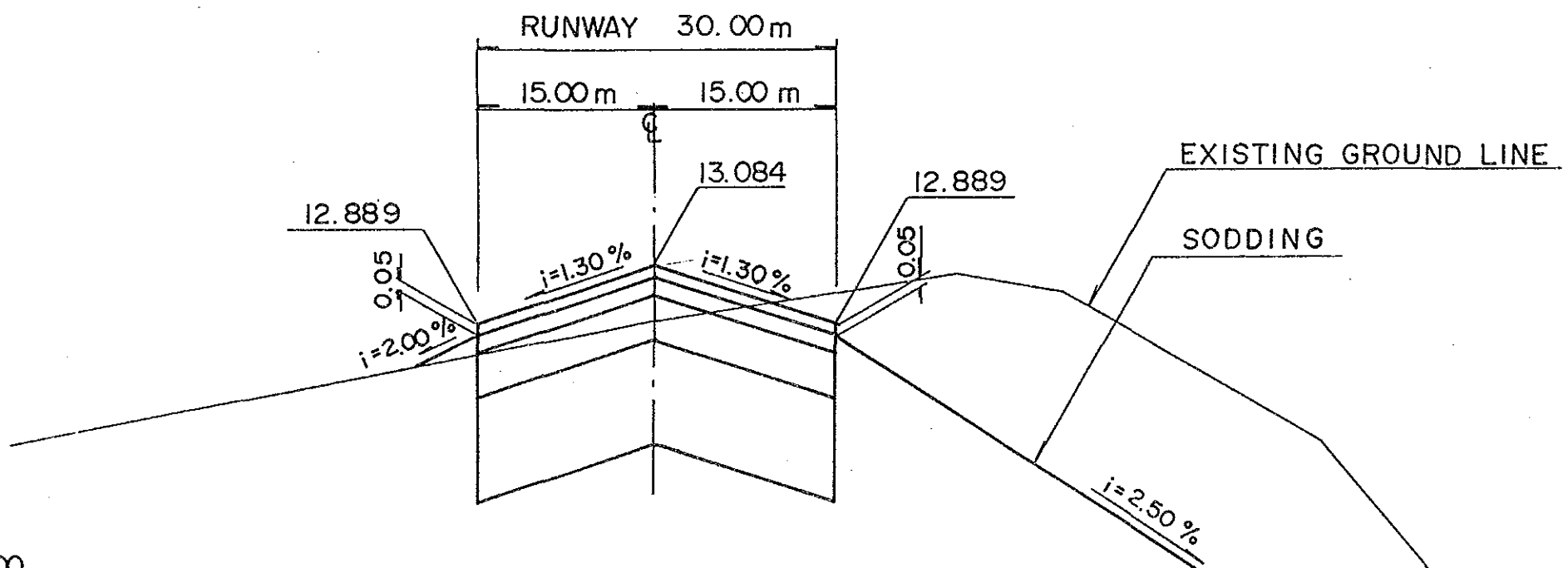

RUNWAY EXTENSION

DL = 12.00

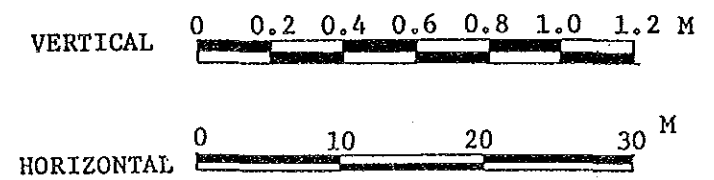

STUDY ON THE MASTER PLAN OF AIRPORT MAINTENANCE AND REHABILITATION	
NAME OF AIRPORT : SELAPARANG/MATARAM	SCALE : V=1/20 H=1/500
NAME OF DRAWING : Typical Cross Section	DWG NO : AMI-4

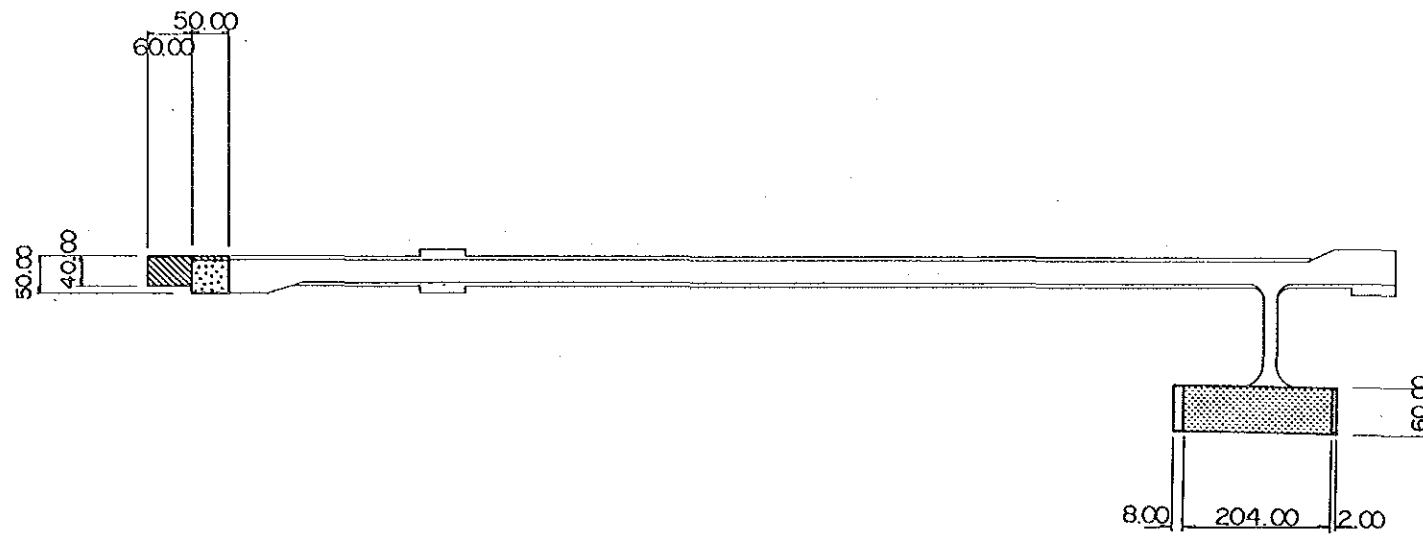

APRON OVERLAY

RUNWAY EXTENSION

APRON EXPANSION

SHOULDER AND OVERRUN

PT-1

PT-2

PT-3

PT-4

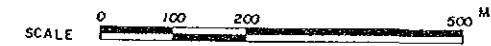
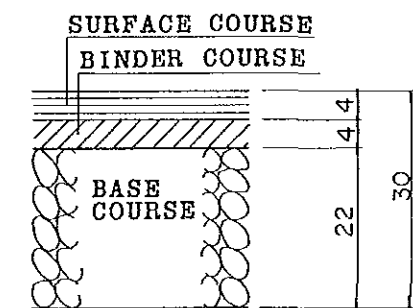
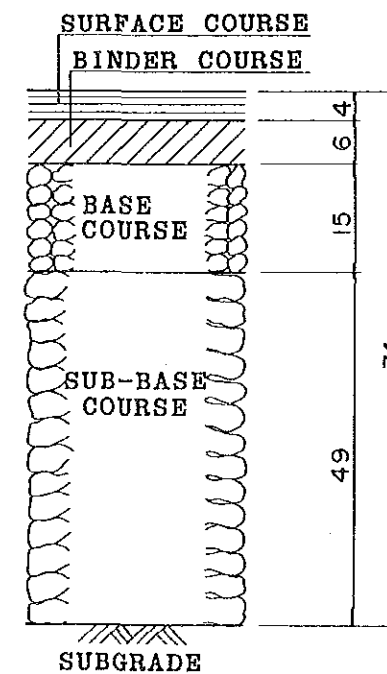
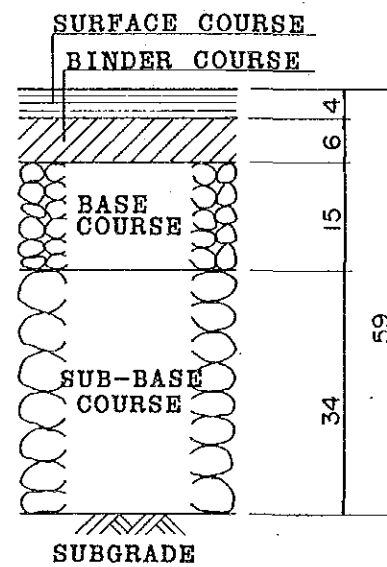
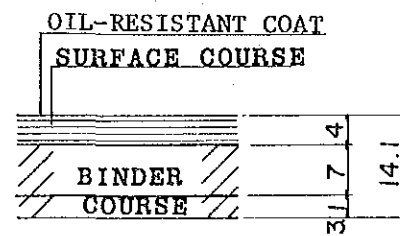

STUDY ON THE MASTER PLAN OF AIRPORT
MAINTENANCE AND REHABILITATION

NAME OF AIRPORT :	SCALE :
SELAPARANG/MATARAM	1/10,000
NAME OF DRAWING :	DWG NO :
Pavement Plan	AMI-5

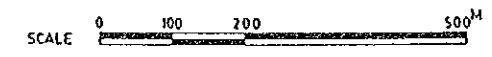
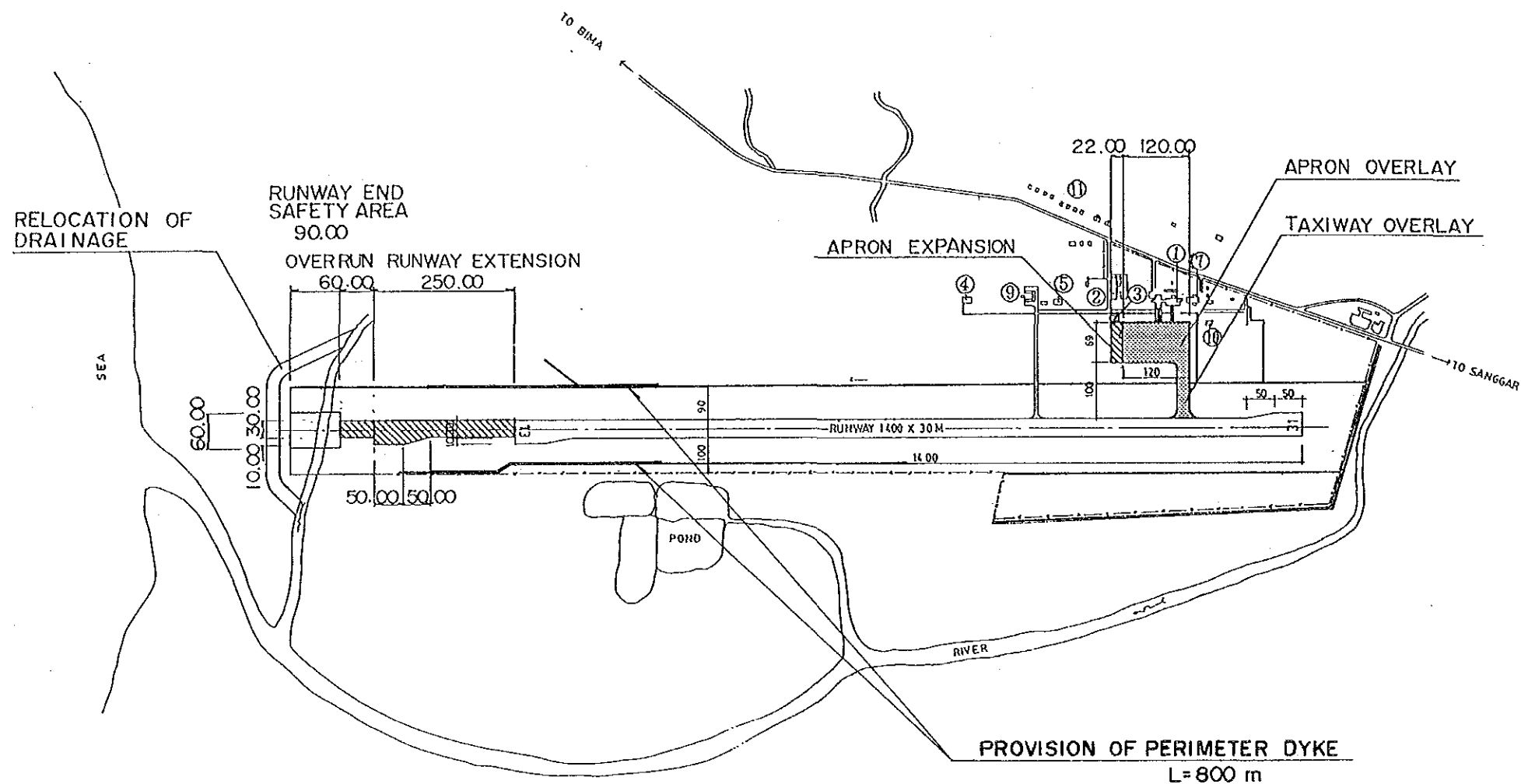

BASIC DATA TABLE			
AIRPORT CLASS	III	RUNWAY DIRECTION	13-31
AIRPORT STATUS	DOMESTIC	INSTRUMENT RUNWAY	
AIRPORT ELEVATION	1M	PAVEMENT STRENGTH	PCN 11 FDZU
AIRPORT REF. POINT (ARP) COORDINATES	08° 30' S 118° 42' E	NAVIGATIONAL AIDS	NDB, VOR
AIRPORT REF. TEMP	27°C-34°C	DISTANCE FROM CITY	21KM

MAJOR BUILDINGS					
No.	Name of Building	tick if available	No.	Name of Building	tick if available
1	Passenger Terminal	✓	7	VIP Building	✓
2	Administration Building	✓	8	Main Power House	
3	Operations Building	✓	9	Fire Station	✓
4	Control Tower	✓	10	Fuel Farm	✓
5	Workshop	✓	11	Staff Housing	✓
6	Cargo Terminal Building				

LEGEND	
—x—x—	Fence
====	Ditch

STUDY ON THE MASTER PLAN OF AIRPORT MAINTENANCE AND REHABILITATION	
NAME OF AIRPORT :	SCALE :
ST, SALAHUDIN/BIMA	1/10,000
NAME OF DRAWING :	DWG NO :
Layout Plan	BMU-1

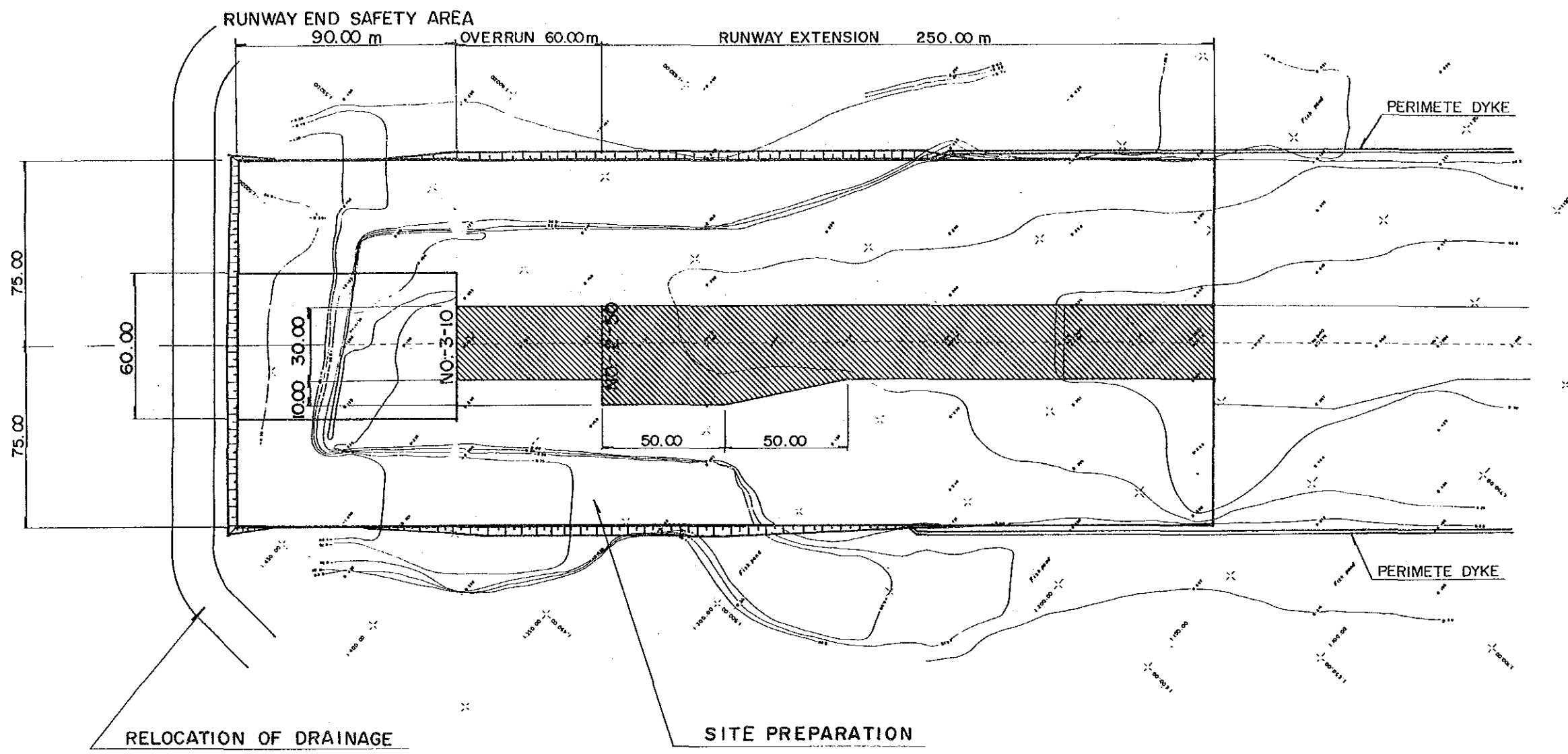

SCALE 0 20 40 60 80 100 M

STUDY ON THE MASTER PLAN OF AIRPORT MAINTENANCE AND REHABILITATION	
NAME OF AIRPORT :	SCALE :
ST, SALAHUDIN/BIMA	1/2, 000
NAME OF DRAWING :	DWG NO :
<i>Detailed Plan</i>	BMU-2

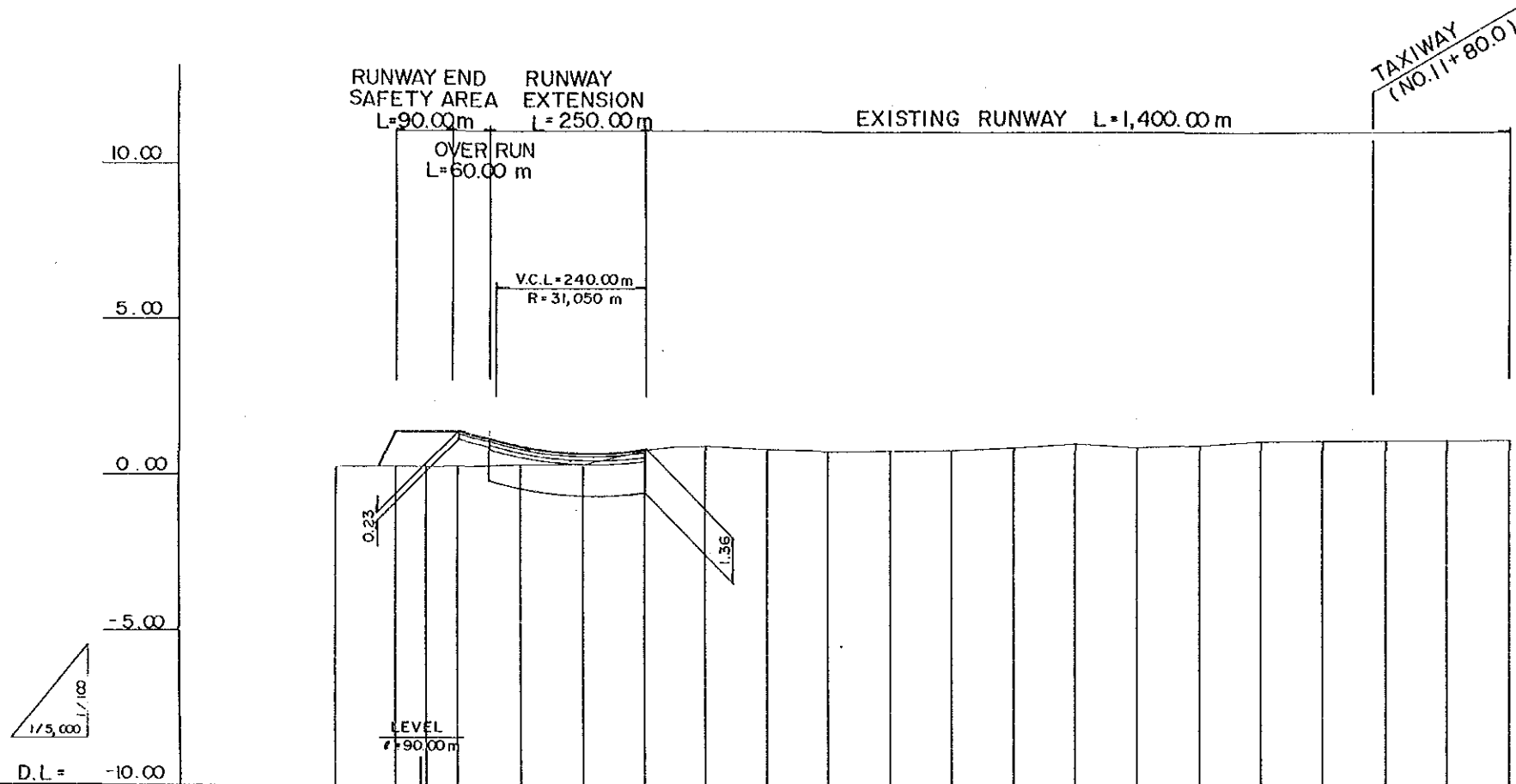

SLOPE																									
CUT OR BANK		1.146	1.136	1.128	0.545	0.356	0.340	0.000																	
PROPOSED HEIGHT		1.366	1.366	1.366	0.842	0.648	0.631	0.742																	
GROUND HEIGHT		0.220	0.230	0.236	0.297	0.292	0.291	0.742	0.878	0.896	0.788	0.768	0.769	0.791	0.880	1.000	0.878	0.942	1.087	1.095	1.096	1.096	1.097	1.092	
ACCUMULATED DISTANCE		-400.00	-350.00	-310.00	200.00	120.00	-100.00	0.00	50.00	100.00	200.00	300.00	400.00	500.00	600.00	700.00	800.00	900.00	1000.00	1100.00	1180.00	1200.00	1300.00	1400.00	
STATION		NO. 4	-50.0	-10.0	NO. 3	NO. 2	-20.0	NO. 1	NO. 0	+50.0	NO. 1	NO. 2	NO. 3	NO. 4	NO. 5	NO. 6	NO. 7	NO. 8	NO. 9	NO. 10	NO. 11	+80.0	NO. 12	NO. 13	NO. 14

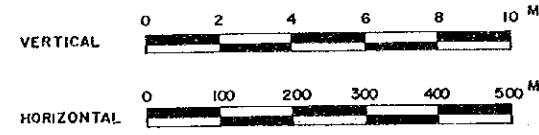

STUDY ON THE MASTER PLAN OF AIRPORT MAINTENANCE AND REHABILITATION	
NAME OF AIRPORT :	SCALE :
ST, SALAHUDIN/BIMA	V=1/200 H=1/10,000
NAME OF DRAWING :	DWG NO :
Runway Profile	BMU-3

NO. 11+80

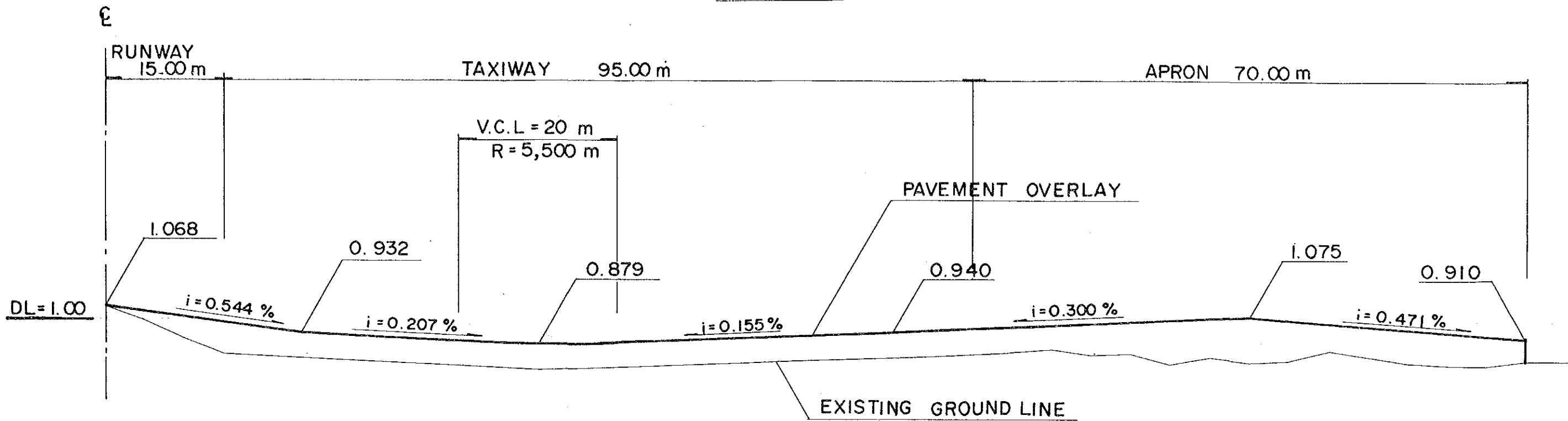

TAXIWAY AND APRON OVERLAY

NO. - 1

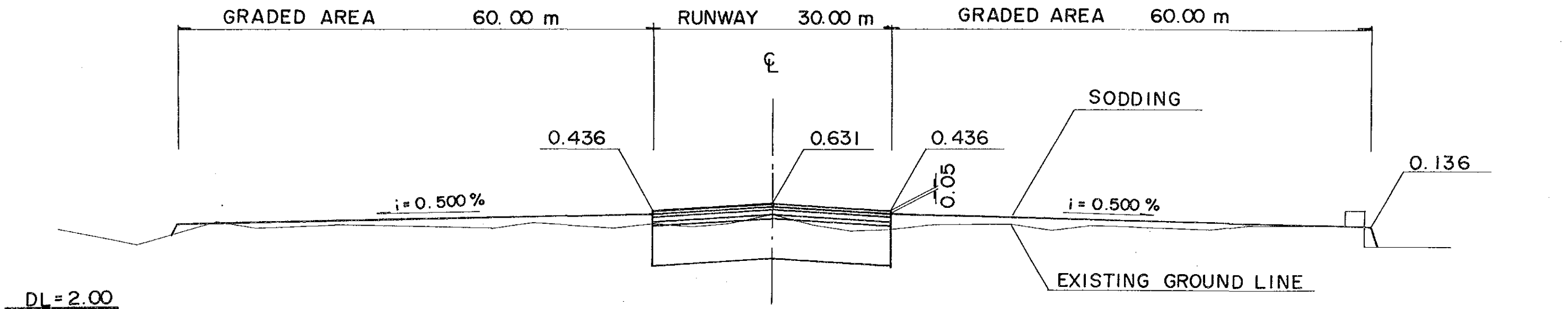

RUNWAY EXTENSION

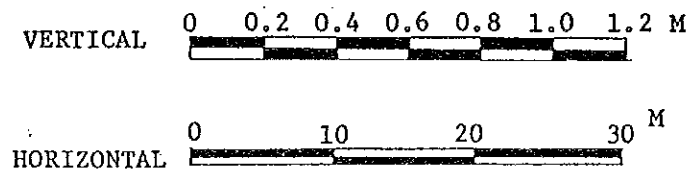

STUDY ON THE MASTER PLAN OF AIRPORT MAINTENANCE AND REHABILITATION	
NAME OF AIRPORT : ST. SALAHUDIN/BIMA	SCALE : V = 1/20 H = 1/500
NAME OF DRAWING : Typical Cross Section	DWG NO : BMU-4

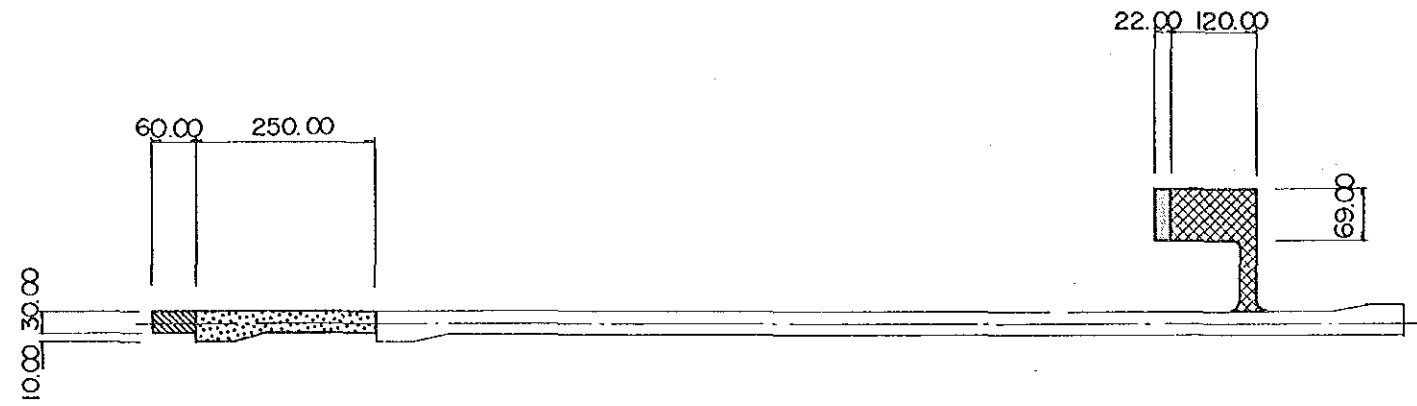

TAXIWAY AND
APRON OVERLAY

RUNWAY EXTENSION

APRON EXPANSION

OVERRUN

PT-1

PT-2

PT-3

PT-4

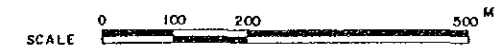
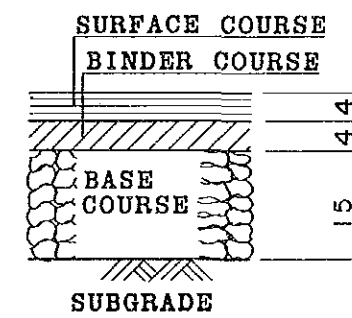
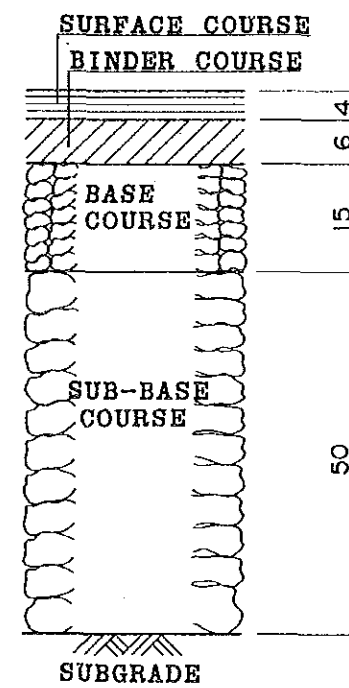
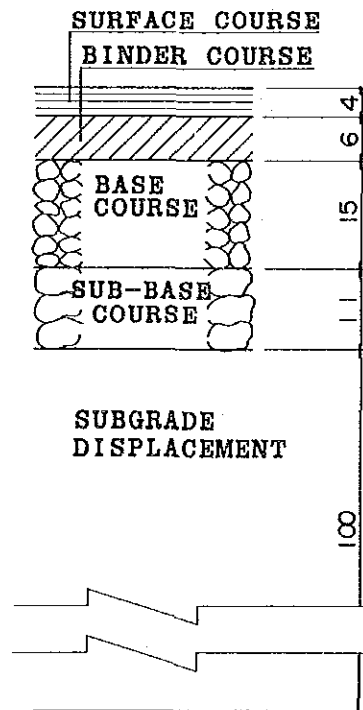
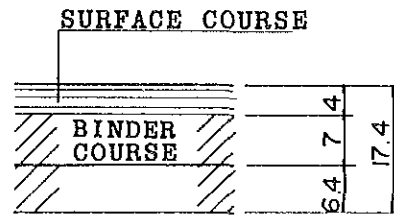

STUDY ON THE MASTER PLAN OF AIRPORT
MAINTENANCE AND REHABILITATION

NAME OF AIRPORT :	SCALE :
ST, SALAHUDIN/BIMA	1/10,000
NAME OF DRAWING :	DWG NO :
Pavement Plan	BMU-5

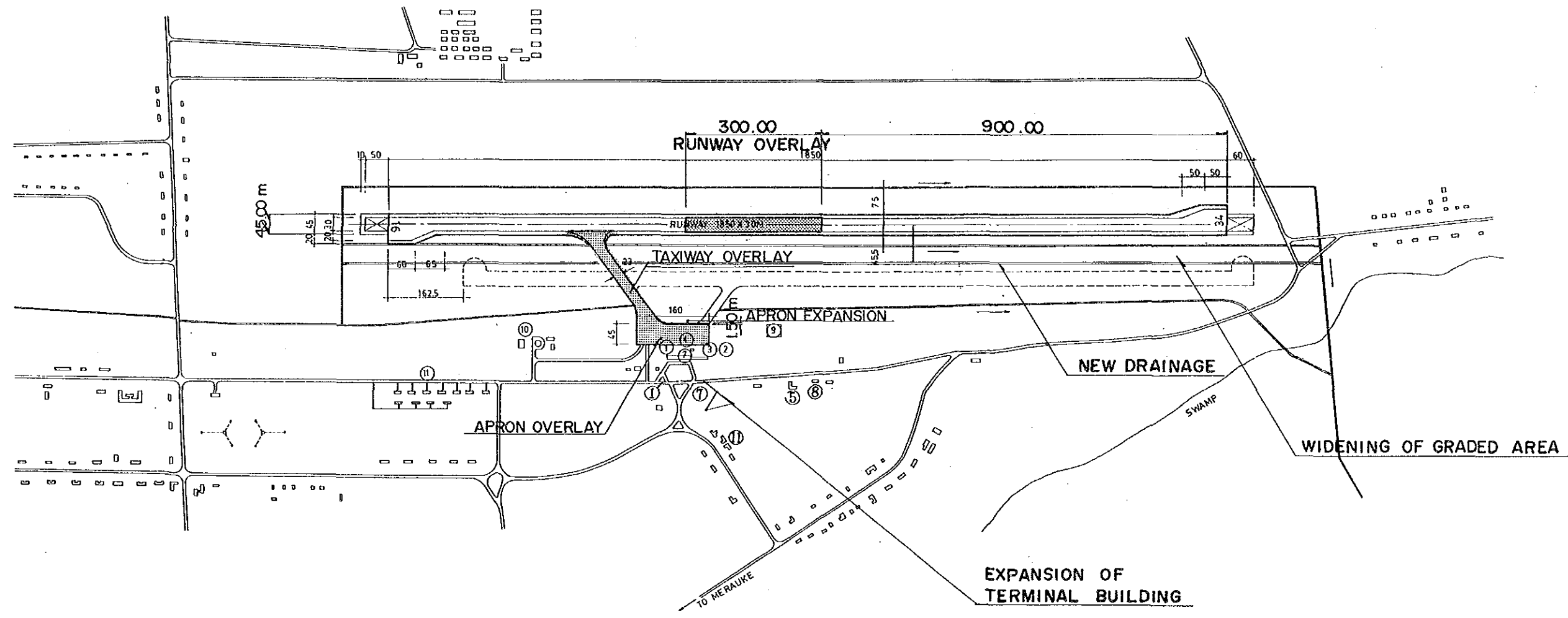
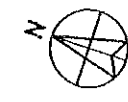

BASIC DATA TABLE			
AIRPORT CLASS	III	RUNWAY DIRECTION	16-34
AIRPORT STATUS	DOMESTIC	INSTRUMENT RUNWAY	
AIRPORT ELEVATION	2.85M	PAVEMENT STRENGTH	PCN 18 FBXU
AIRPORT REF. POINT (ARP) COORDINATES	0° 38' S 140° 28' E	NAVIGATIONAL AIDS	NDB, VOR/DME
AIRPORT REF. TEMP	26°C	DISTANCE FROM CITY	4.3KM

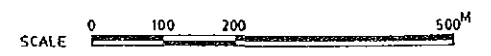

MAJOR BUILDINGS					
No.	Name of Building	tick if available	No.	Name of Building	tick if available
1	Passenger Terminal	✓	7	VIP Building	✓
2	Administration Building	✓	8	Main Power House	✓
3	Operations Building	✓	9	Fire Station	✓
4	Control Tower	✓	10	Fuel Farm	✓
5	Workshop	✓	11	Staff Housing	✓
6	Cargo Terminal Building				

LEGEND	
—x—x—	Fence
====	Ditch

STUDY ON THE MASTER PLAN OF AIRPORT MAINTENANCE AND REHABILITATION	
NAME OF AIRPORT :	SCALE :
MOPAH/MERAUKE	1/10,000
NAME OF DRAWING :	DWG NO :
Layout Plan	MKQ-1

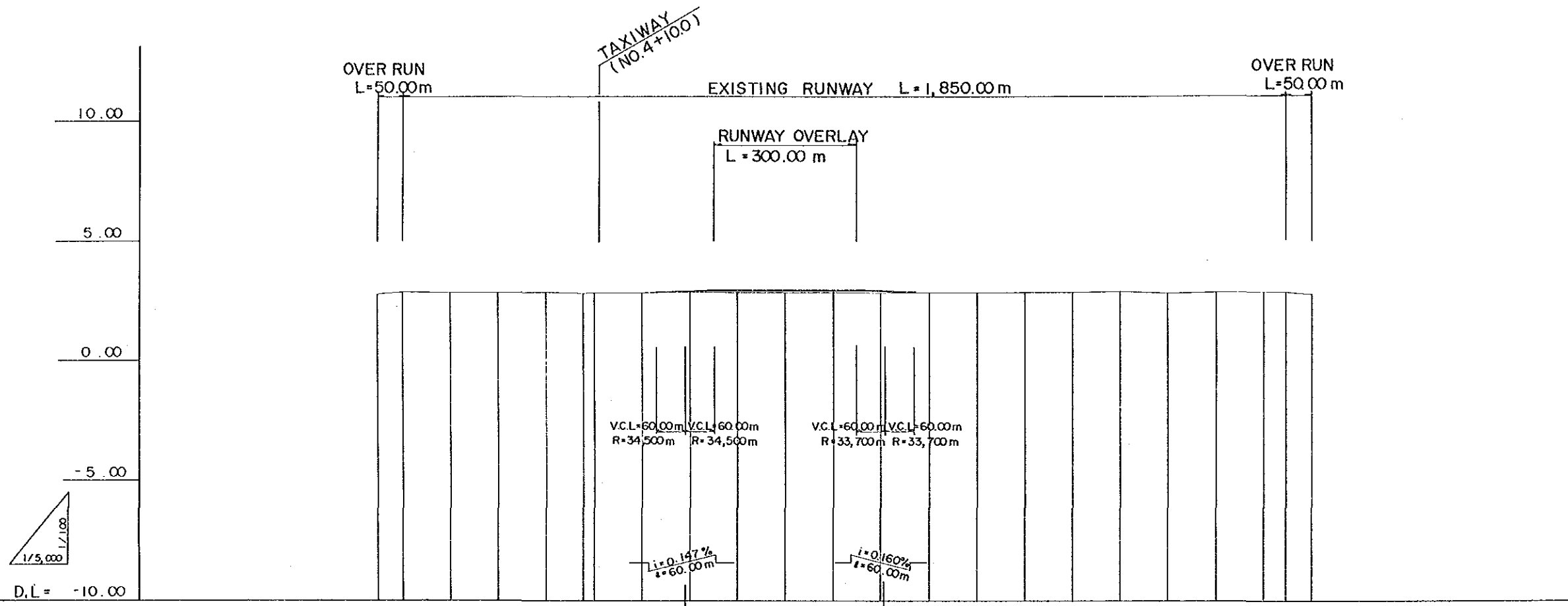

SLOPE																				
OVERLAY THICKNESS																				
PROPOSED HEIGHT																				
GROUND HEIGHT																				
ACCUMULATED DISTANCE																				
STATION																				

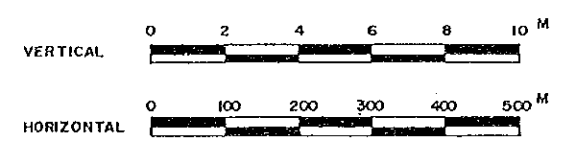

STUDY ON THE MASTER PLAN OF AIRPORT MAINTENANCE AND REHABILITATION	
NAME OF AIRPORT : MOPAH/MERAUKE	SCALE : V=1/200 H=1/10,000
NAME OF DRAWING : Runway Profile	DWG NO : MKQ-2

NO. 8

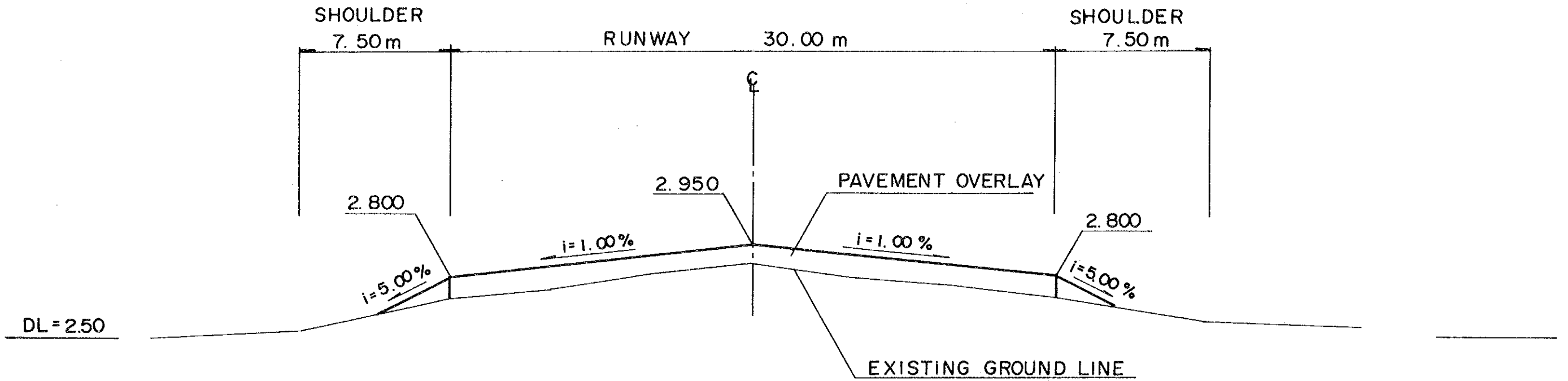

RUNWAY OVERLAY

NO. 6

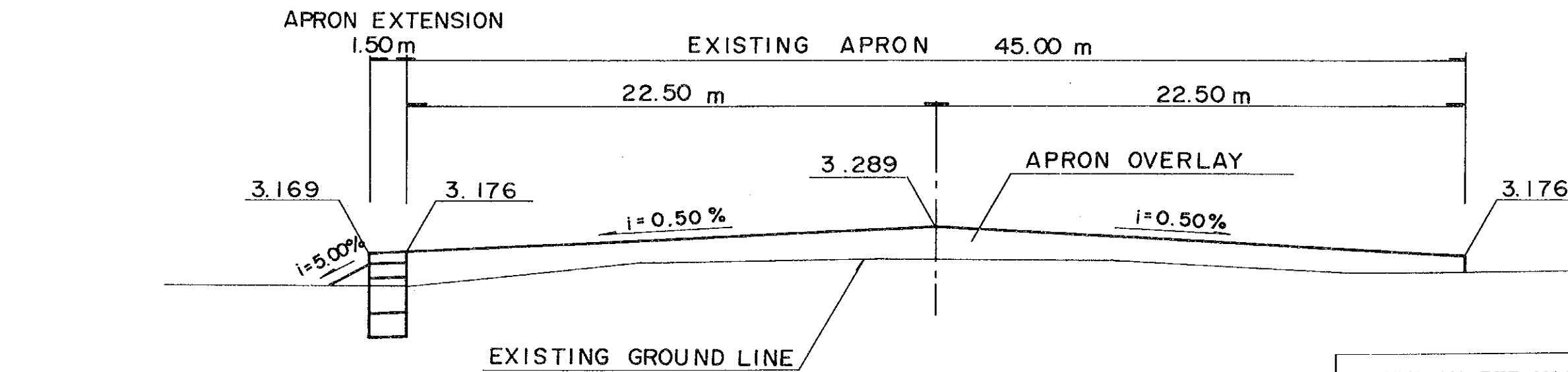

APRON OVERLAY AND EXPANSION

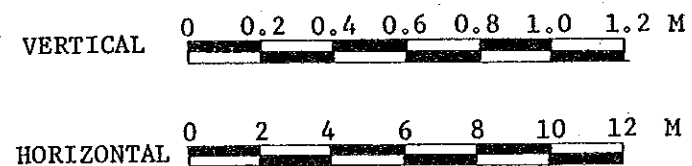

STUDY ON THE MASTER PLAN OF AIRPORT MAINTENANCE AND REHABILITATION	
NAME OF AIRPORT : MOPAH/MERAUKE	SCALE : V = 1/20 H = 1/200
NAME OF DRAWING : Typical Cross Section	DWG NO : MKQ-3

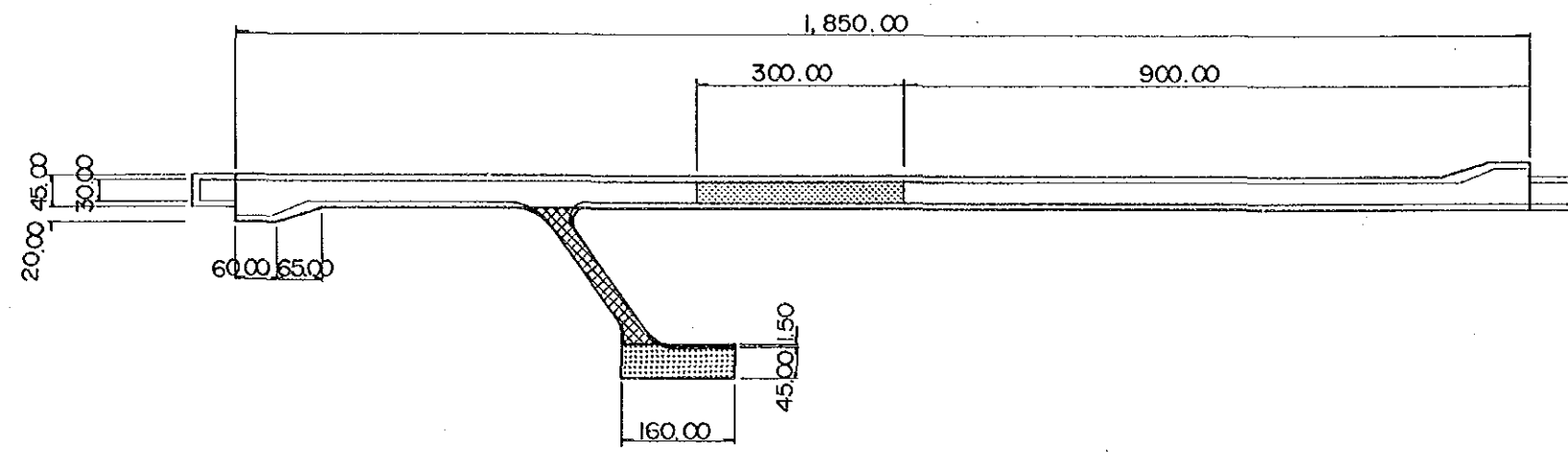
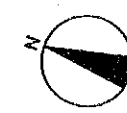

RUNWAY OVERLAY

TAXIWAY OVERLAY

APRON EXPANSION

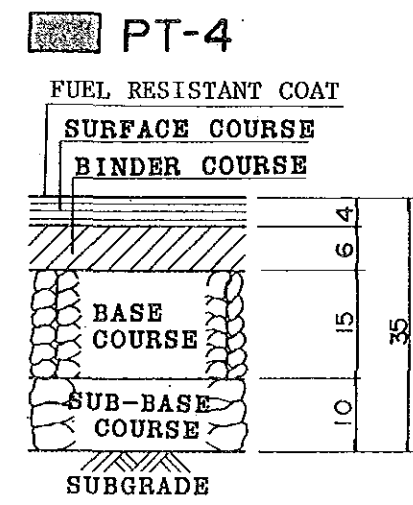
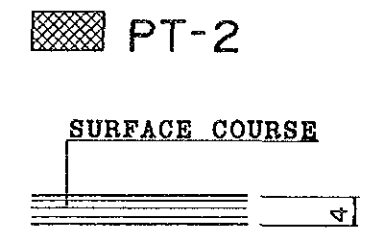
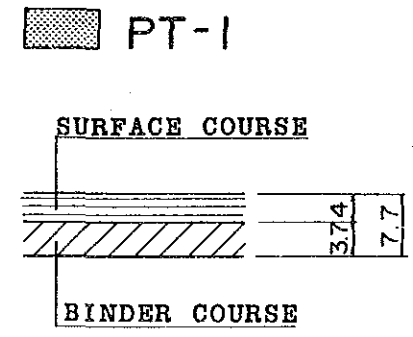

APRON OVERLAY

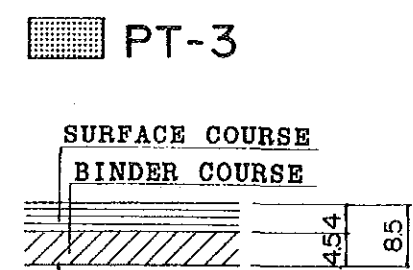

DEEP CRACKS OF EXISTING CEMENT CONCRETE PAVEMENT TO BE FILLED UP WITH STRAIGHT ASPHALT

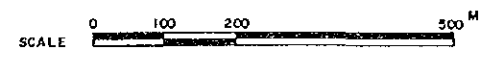

STUDY ON THE MASTER PLAN OF AIRPORT MAINTENANCE AND REHABILITATION	
NAME OF AIRPORT :	SCALE :
MOPAH/MERAUKE	1/10,000
NAME OF DRAWING :	DWG NO :
Pavement Plan	MKQ-4

AIRSIDE

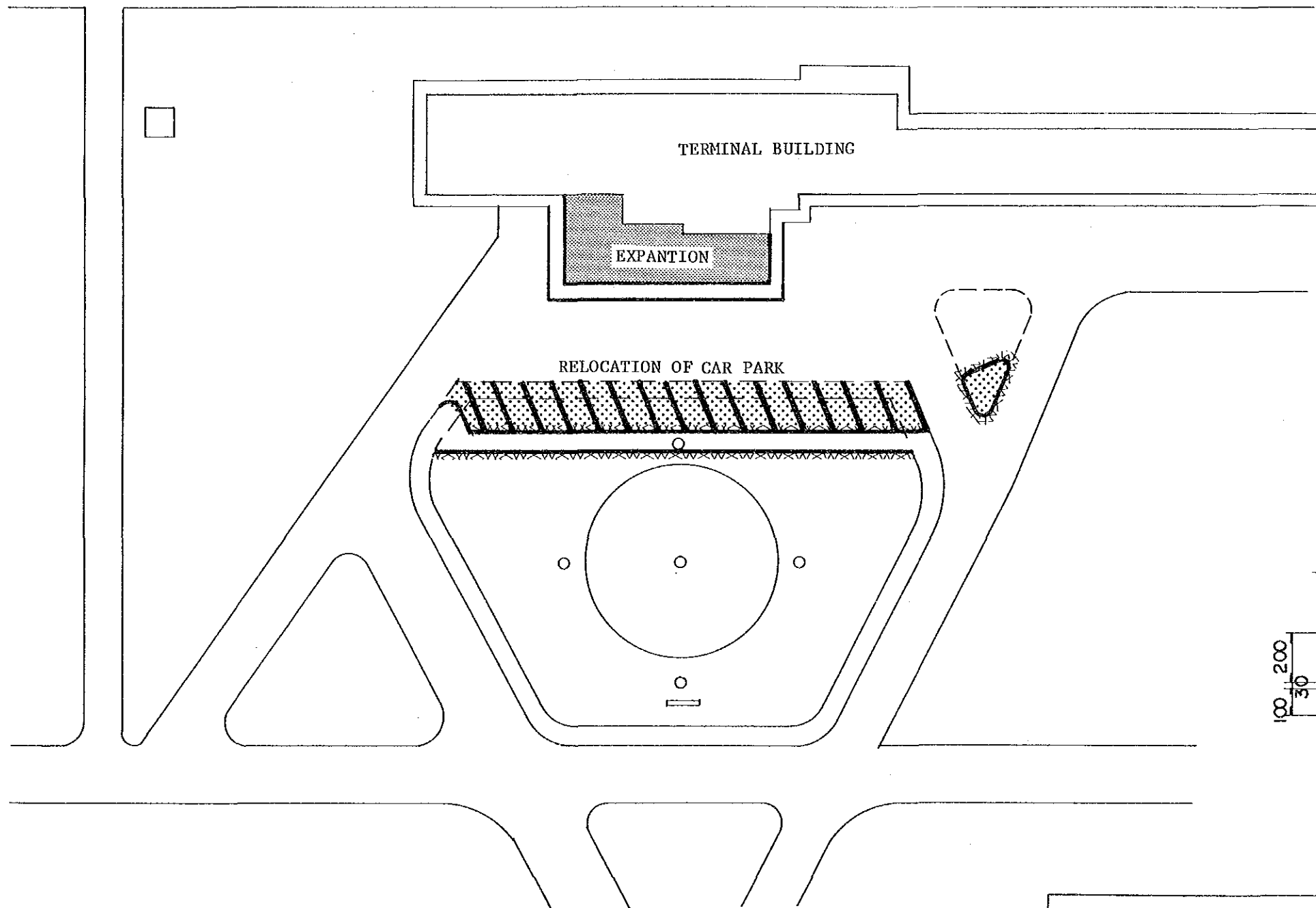

PAVEMENT

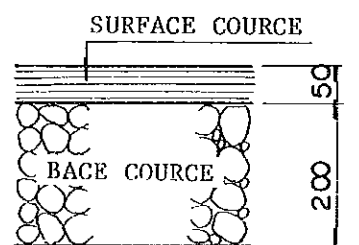

CURB STONE

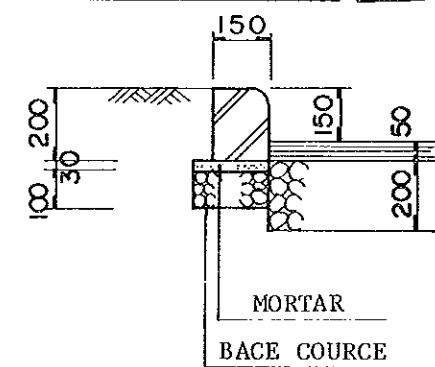

STUDY ON THE MASTER PLAN OF AIRPORT MAINTENANCE AND REHABILITATION	
NAME OF AIRPORT : MOPAH/MERAUKE	SCALE : 1 / 500
NAME OF DRAWING : Terminal Area Layout Plan	DWG NO : MKQ-5

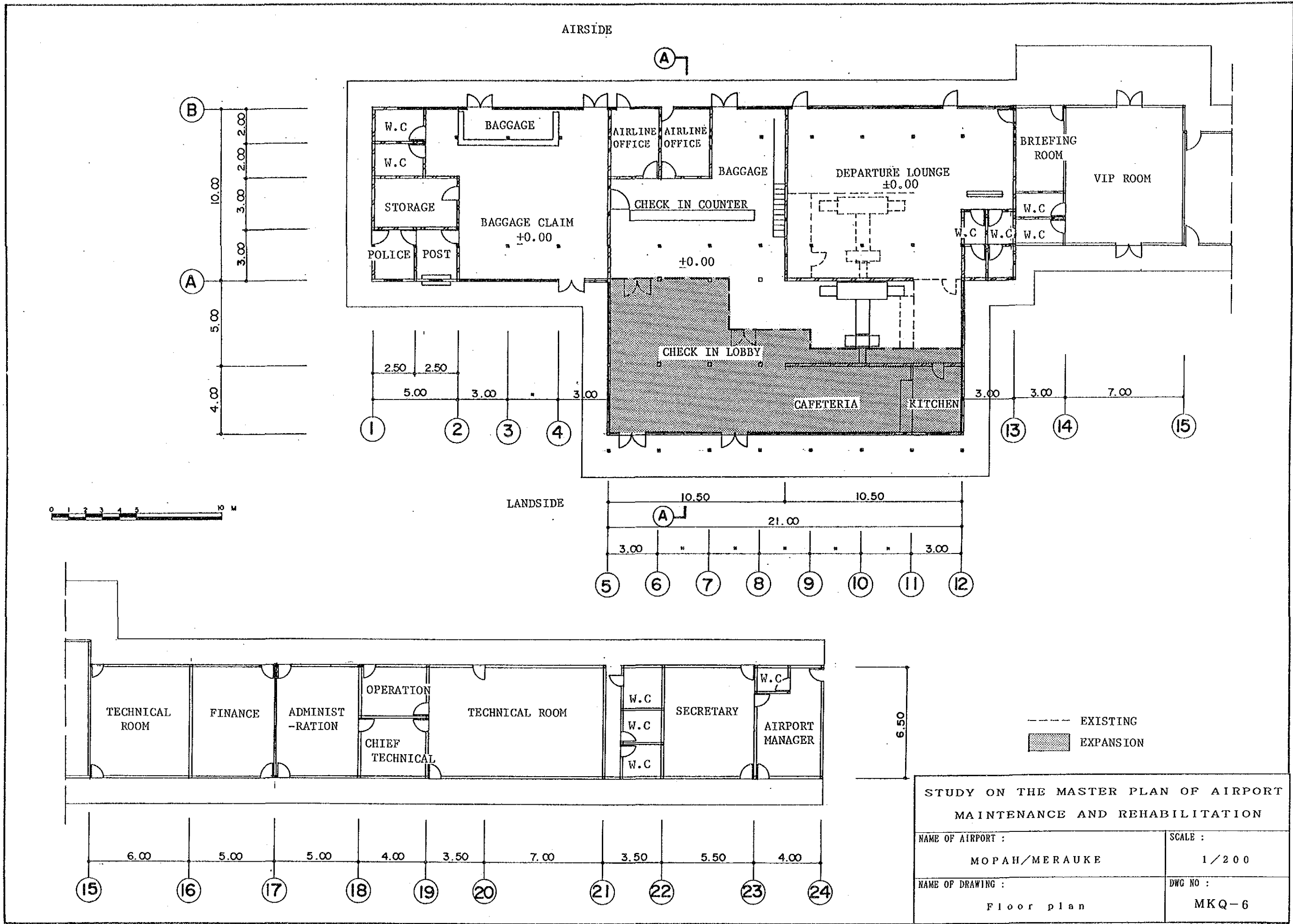

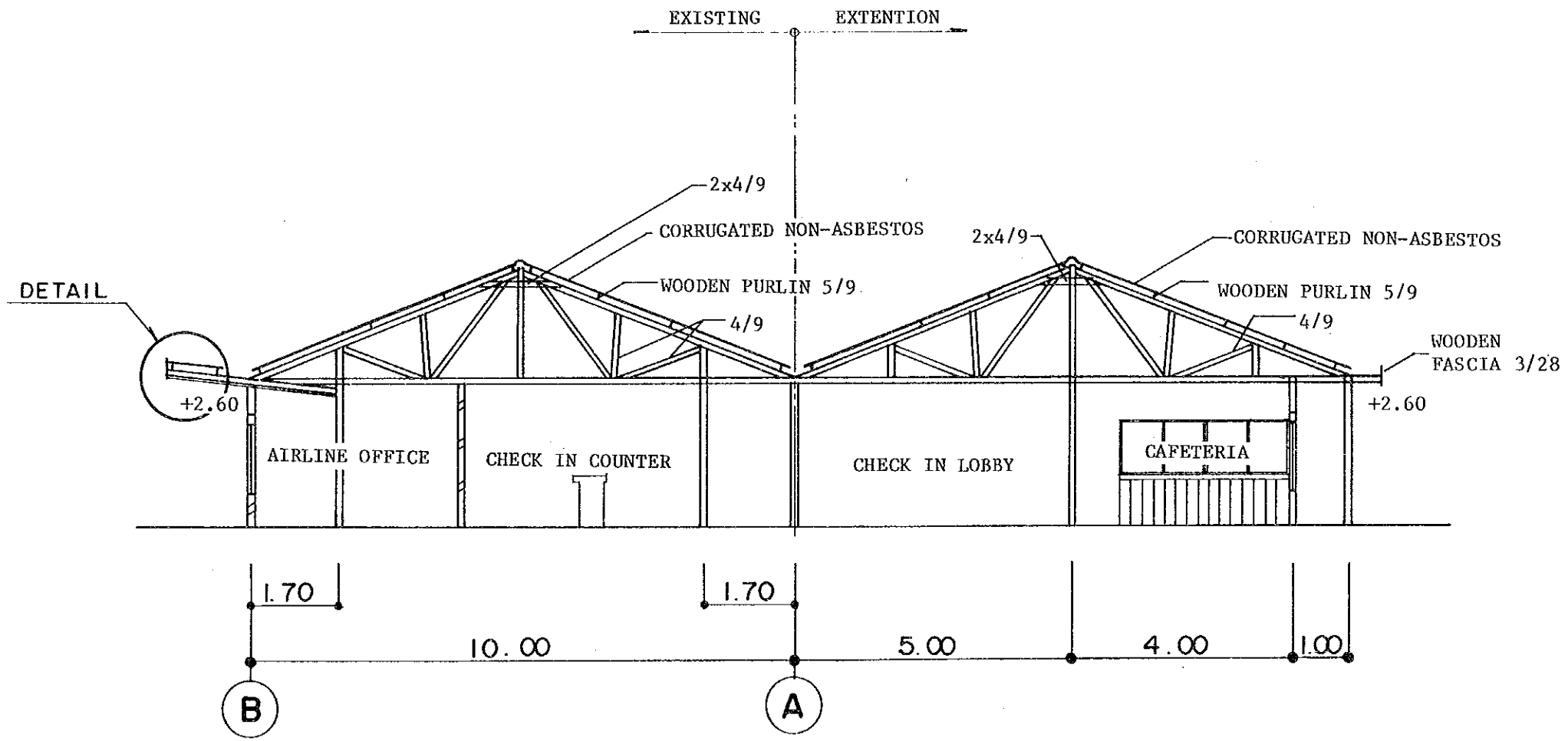

Ⓐ-Ⓐ SECTION

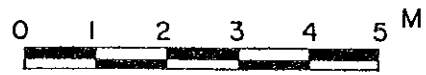

STUDY ON THE MASTER PLAN OF AIRPORT MAINTENANCE AND REHABILITATION	
NAME OF AIRPORT :	SCALE :
MOPAH/MERAUKE	1/100
NAME OF DRAWING :	DWG NO :
Section	MKQ-7

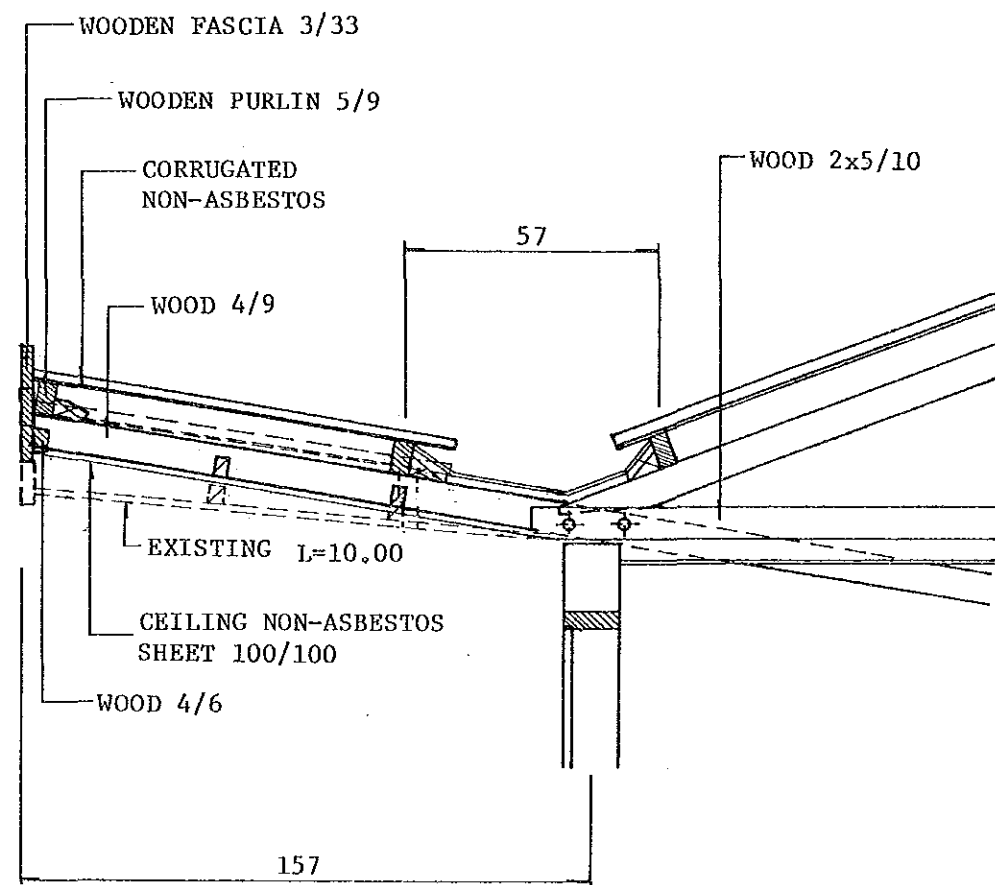

DETAIL

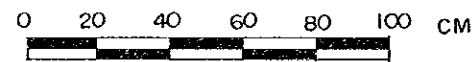

STUDY ON THE MASTER PLAN OF AIRPORT MAINTENANCE AND REHABILITATION	
NAME OF AIRPORT : MOPAH/MERAUKE	SCALE : 1/200
NAME OF DRAWING : Detail	DWG NO : MKQ-8

JICA