

**KINGDOM OF THAILAND
ROYAL IRRIGATION DEPARTMENT
MINISTRY OF AGRICULTURE AND COOPERATIVES**

**THE FEASIBILITY STUDY
ON
THE AGRICULTURAL WATER DEVELOPMENT PROJECT
OF
BANG PAKONG RIVER BASIN**

Drawing

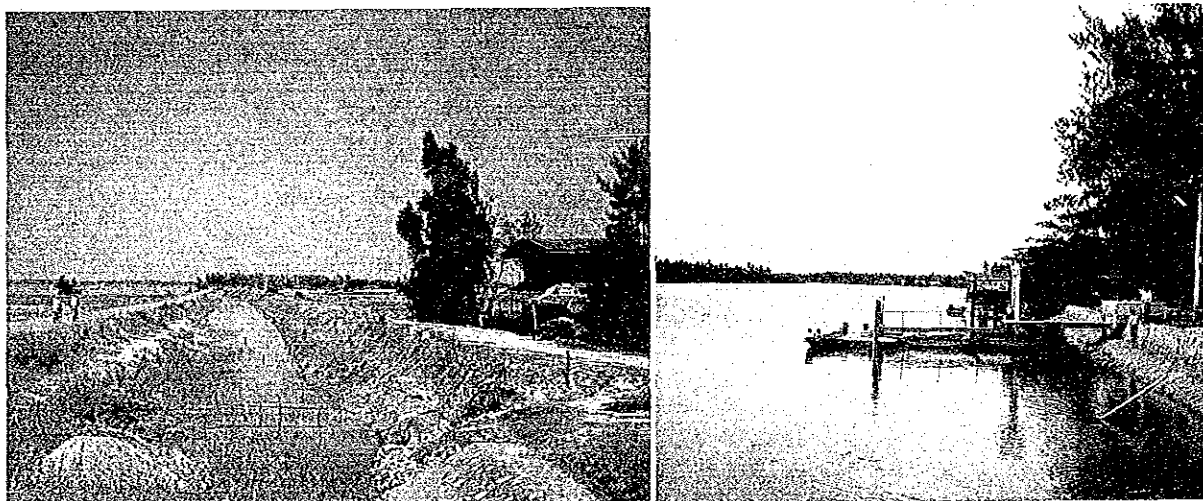

OCTOBER 1990

JAPAN INTERNATIONAL COOPERATION AGENCY

AFT
SECRET
90-67

RY

**KINGDOM OF THAILAND
ROYAL IRRIGATION DEPARTMENT
MINISTRY OF AGRICULTURE AND COOPERATIVES**

**THE FEASIBILITY STUDY
ON
THE AGRICULTURAL WATER DEVELOPMENT PROJECT
OF
BANG PAKONG RIVER BASIN**

JICA LIBRARY

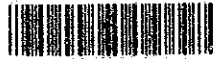

1086339171

21717

DRAWING

OCTOBER 1990

JAPAN INTERNATIONAL COOPERATION AGENCY

OVERALL BASIN STUDY

<u>DRAWING NO.</u>	<u>T I T L E</u>
M - 1	GENERAL LOCATION MAP
M - 2	KHLONG LUANG IRRIGATION PROJECT
M - 3	SI YAT IRRIGATION PROJECT
M - 4	PHRA SATHUNG IRRIGATION PROJECT
M - 5	PHRA PRONG IRRIGATION PROJECT
M - 6	UPPER PHRA PRONG IRRIGATION PROJECT
M - 7	HUAI SAMONG IRRIGATION PROJECT
M - 8	HUAI SAI NOI - SAI YAI IRRIGATION PROJECT
M - 9	NONG KAE0 IRRIGATION PROJECT
M - 10	THA DAN IRRIGATION PROJECT
M - 11	BAN NA IRRIGATION PROJECT
M - 12	LAM PHRAYA THAN IRRIGATION PROJECT

FEASIBILITY STUDY

<u>DRAWING NO.</u>	<u>T I T L E</u>
F - 1	GENERAL LOCATION MAP
F - 2	KHLONG SI YAT DAM LOCATION MAP
F - 3	KHLONG SI YAT DAM SITE PLAN
F - 4	KHLONG SI YAT DAM MAIN AND SADDLE DAMS
F - 5	KHLONG SI YAT DAM OUTLET WORKS
F - 6	KHLONG SI YAT DAM SPILLWAY
F - 7	BANG PAKONG DIVERSION DAM LOCATION MAP

國際協力事業團

21717

<u>DRAWING NO.</u>	<u>T I T L E</u>
F - 8	BANG PAKONG DIVERSION DAM GENERAL PLAN
F - 9	BANG PAKONG DIVERSION DAM ELEVATION
F - 10	BANG PAKONG DIVERSION DAM TYPICAL SECTION
F - 11	BANG PAKONG DIVERSION DAM CLOSURE DAM
F - 12	THA LAT MAIN CANAL GENERAL PLAN
F - 13	THA LAT MAIN CANAL PROFILE AND TYPICAL SECTION
F - 14	THA LAT MAIN CANAL DIVERSION WEIR
F - 15	BANG PAKONG MAIN CANAL PLAN OF PUMPING STATION
F - 16	BANG PAKONG MAIN CANAL SECTION OF PUMPING STATION
F - 17	BANG PAKONG MAIN CANAL DIVERSION WORK
F - 18	BANG PAKONG MAIN CANAL PROFILE AND TYPICAL SECTION INTAKE CANAL & LEFT MAIN CANAL
F - 19	BANG PAKONG MAIN CANAL PROFILE AND TYPICAL SECTION RIGHT MAIN CANAL
F - 20	SI YAT MAIN CANAL GENERAL PLAN
F - 21	SI YAT MAIN CANAL PROFILE AND TYPICAL SECTION
F - 22	CANAL RELATED STRUCTURE (1) TYPICAL SIPHON
F - 23	CANAL RELATED STRUCTURE (2) TYPICAL ROAD CROSSING AND DROP
F - 24	CANAL RELATED STRUCTURE (3) TYPICAL HEAD GATE
F - 25	CANAL RELATED STRUCTURE (4) END CHCK
F - 26	CANAL RELATED STRUCTURE (5) TYPICAL TURN-OUT

OVERALL BASIN STUDY

GENERAL LOCATION MAP

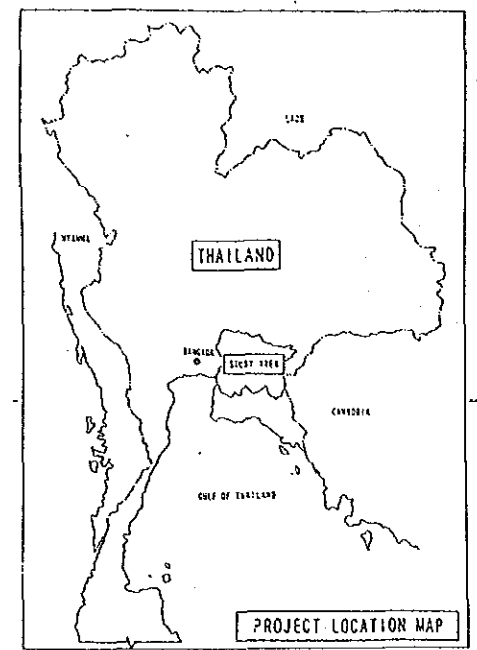

Maenum Nakhon Nayok Sub-Basin
C. A=1,933sq. km

Maenum Hanuman Sub-Basin
C. A=2,130sq. km

Upper Bang Pakong Sub-Basin
C. A=2,757sq. km



Middle Phra Prong Sub-Basin
C. A= 970sq. km

Upper Phra Prong Sub-Basin
C. A=1,628sq. km

Lower Bang Pakong Sub-Basin
C. A=3,106sq. km

Khlong Tha Lat Sub-Basin
C. A=2,493sq. km

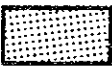
Khlong Phra Sathung Sub-Basin
C. A=2,643sq. km

-  EXISTING IRRIGATION PROJECT
-  AREA NEWLY DEVELOPED
-  PROPOSED DAM/RESERVOIR

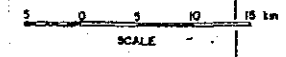

FEASIBILITY STUDY ON THE THA LAT RIVER BASIN DEVELOPMENT PROJECT

GENERAL LOCATION MAP

DRAWING NO. M - 1

JAPAN INTERNATIONAL COOPERATION AGENCY

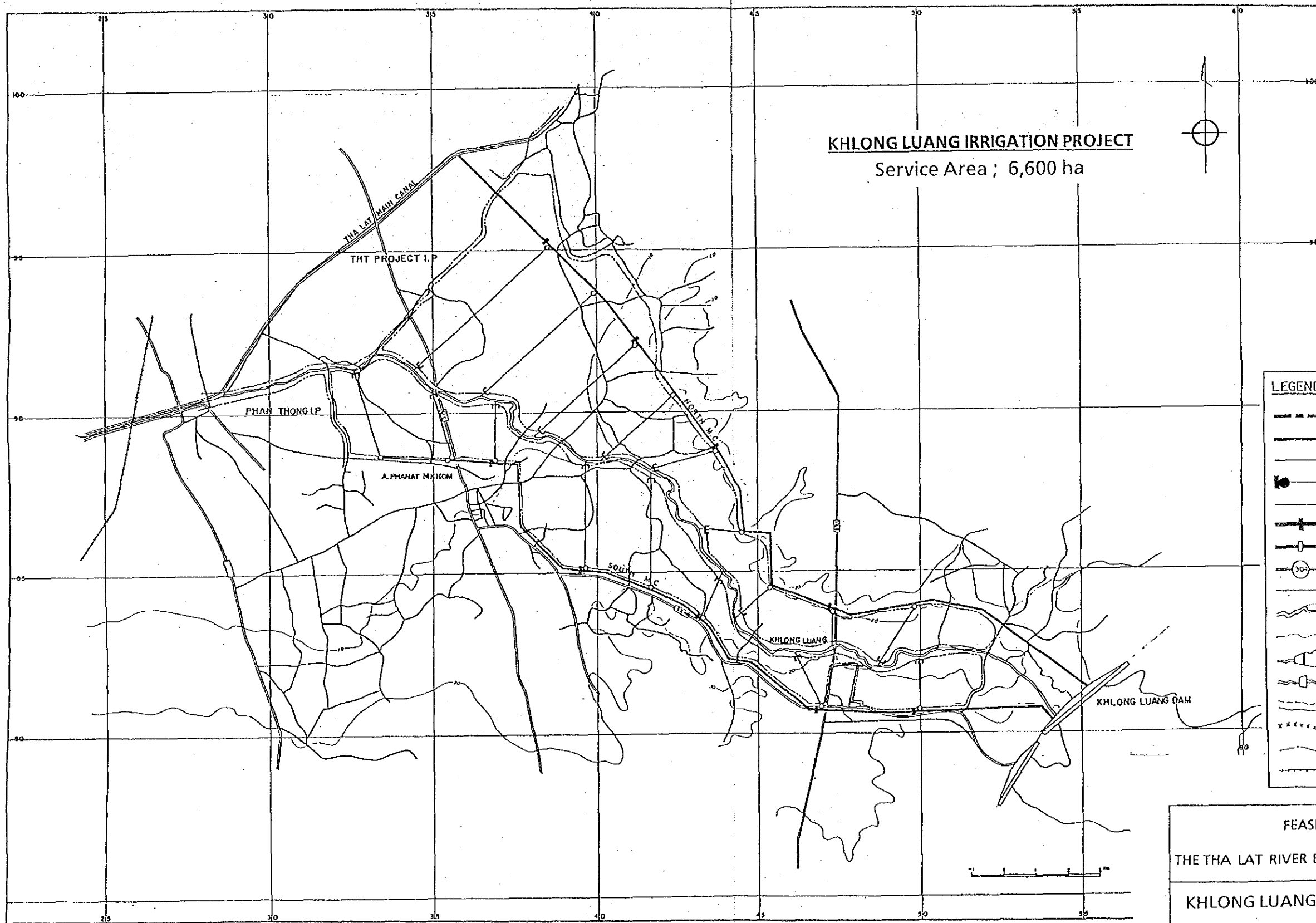

KHLONG LUANG IRRIGATION PROJECT
Service Area ; 6,600 ha

LEGEND	
	MAIN CANAL TO BE REHABILITATED
	MAIN CANAL TO BE CONSTRUCTED
	LATERAL CANAL
	HEAD GATE
	END CHECK
	CHECK NEWLY CONSTRUCTED
	EXISTING CHECK
	MAIN ROAD
	LOCAL ROAD
	MAIN RIVER
	BRANCH RIVER
	DAM & RESERVOIR
	DIVERSION DAM
	PROJECT BOUNDARY
	CHANGWAT BOUNDARY
	AMPHOE BOUNDARY
	RAIL WAY

FEASIBILITY STUDY
ON
THE THA LAT RIVER BASIN DEVELOPMENT PROJECT

KHLONG LUANG IRRIGATION PROJECT

DRAWING NO. M - 2

JAPAN INTERNATIONAL COOPERATION AGENCY

SI YAT IRRIGATION PROJECT
Service Area ; 8,500 ha

- LEGEND**
- MAIN CANAL TO BE REHABILITATED
 - MAIN CANAL TO BE CONSTRUCTED
 - LATERAL CANAL
 - ⊕ HEAD GATE
 - ⊙ END CHECK
 - ⊥ CHECK NEWLY CONSTRUCTED
 - ⊥ EXISTING CHECK
 - ⊙ MAIN ROAD
 - LOCAL ROAD
 - ~ MAIN RIVER
 - ~ BRANCH RIVER
 - ⊥ DAM & RESERVOIR
 - ⊥ DIVERSION DAM
 - PROJECT BOUNDARY
 - ×××××××× CHANGWAT BOUNDARY
 - AMPHOE BOUNDARY
 - RAIL WAY

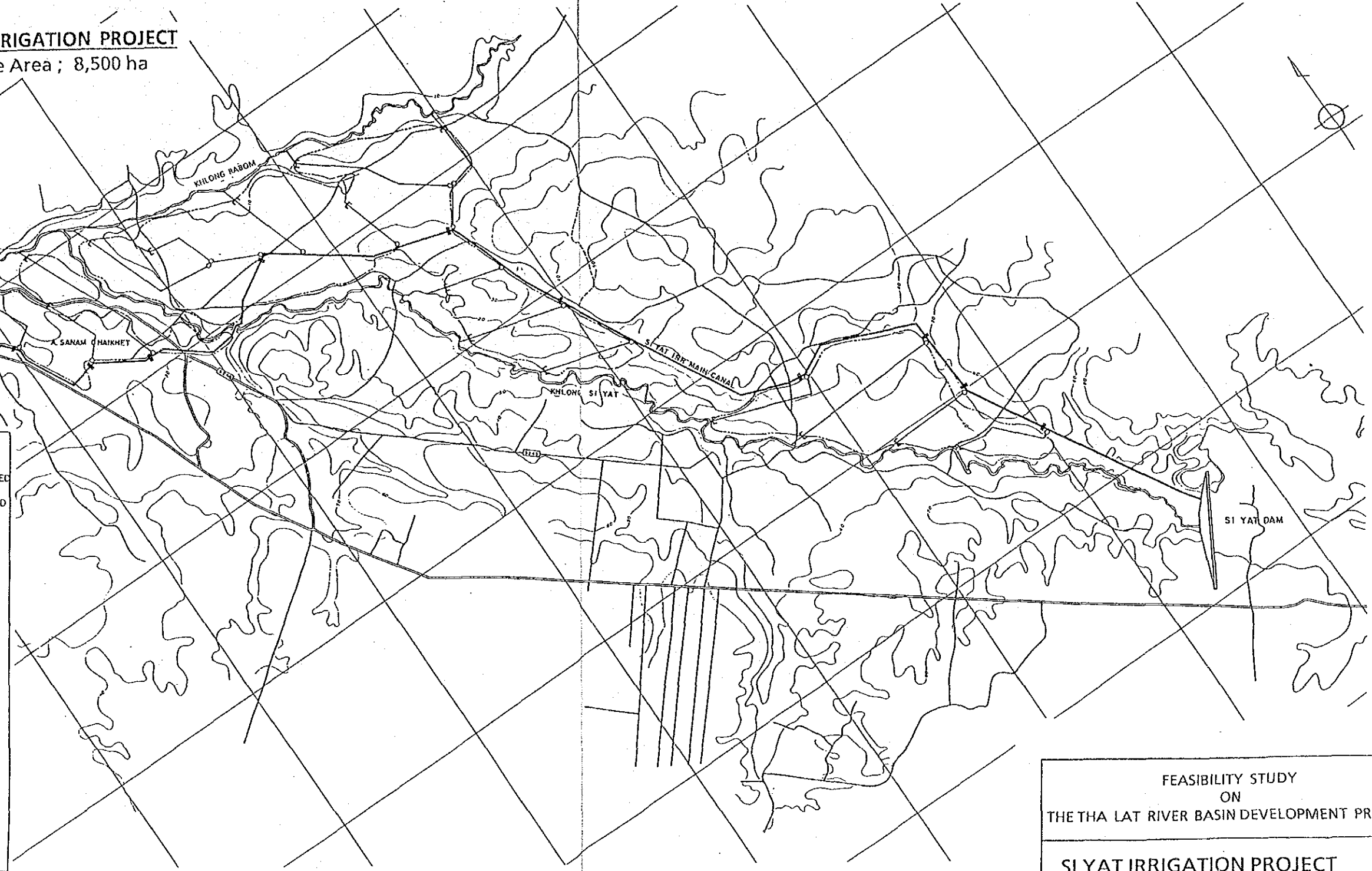

SCALE 1:50,000

FEASIBILITY STUDY
ON
THE THA LAT RIVER BASIN DEVELOPMENT PROJECT

SI YAT IRRIGATION PROJECT

DRAWING NO. M - 3

JAPAN INTERNATIONAL COOPERATION AGENCY

PHRA SATHUNG IRRIGATION PROJECT

Service Area ; 37,000 ha

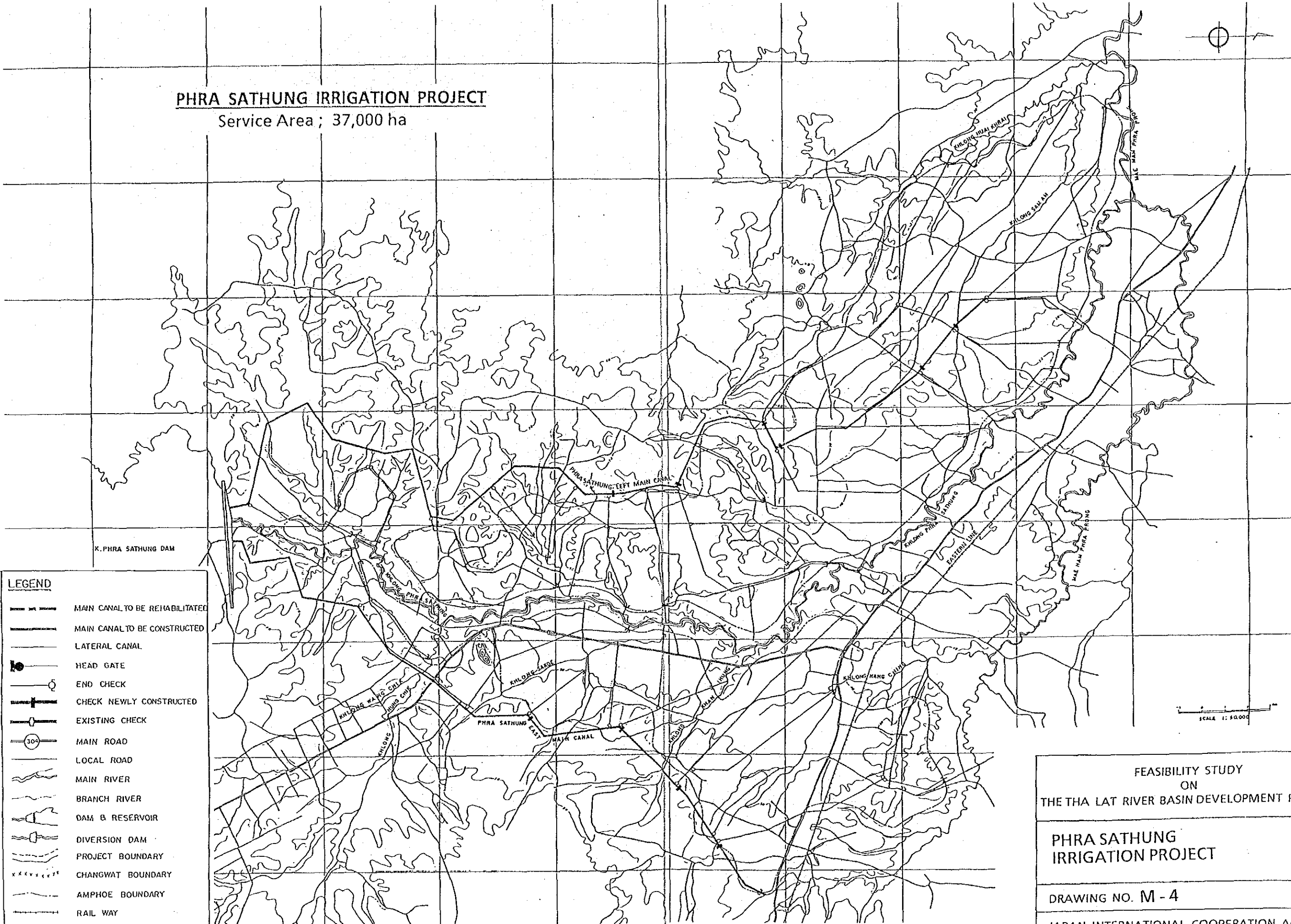

LEGEND	
	MAIN CANAL TO BE REHABILITATED
	MAIN CANAL TO BE CONSTRUCTED
	LATERAL CANAL
	HEAD GATE
	END CHECK
	CHECK NEWLY CONSTRUCTED
	EXISTING CHECK
	MAIN ROAD
	LOCAL ROAD
	MAIN RIVER
	BRANCH RIVER
	DAM & RESERVOIR
	DIVERSION DAM
	PROJECT BOUNDARY
	CHANGWAT BOUNDARY
	AMPHOE BOUNDARY
	RAIL WAY

FEASIBILITY STUDY
ON
THE THA LAT RIVER BASIN DEVELOPMENT PROJECT

**PHRA SATHUNG
IRRIGATION PROJECT**

DRAWING NO. M - 4

JAPAN INTERNATIONAL COOPERATION AGENCY

PHRA PRONG IRRIGATION PROJECT

Service Area ; 40,700 ha

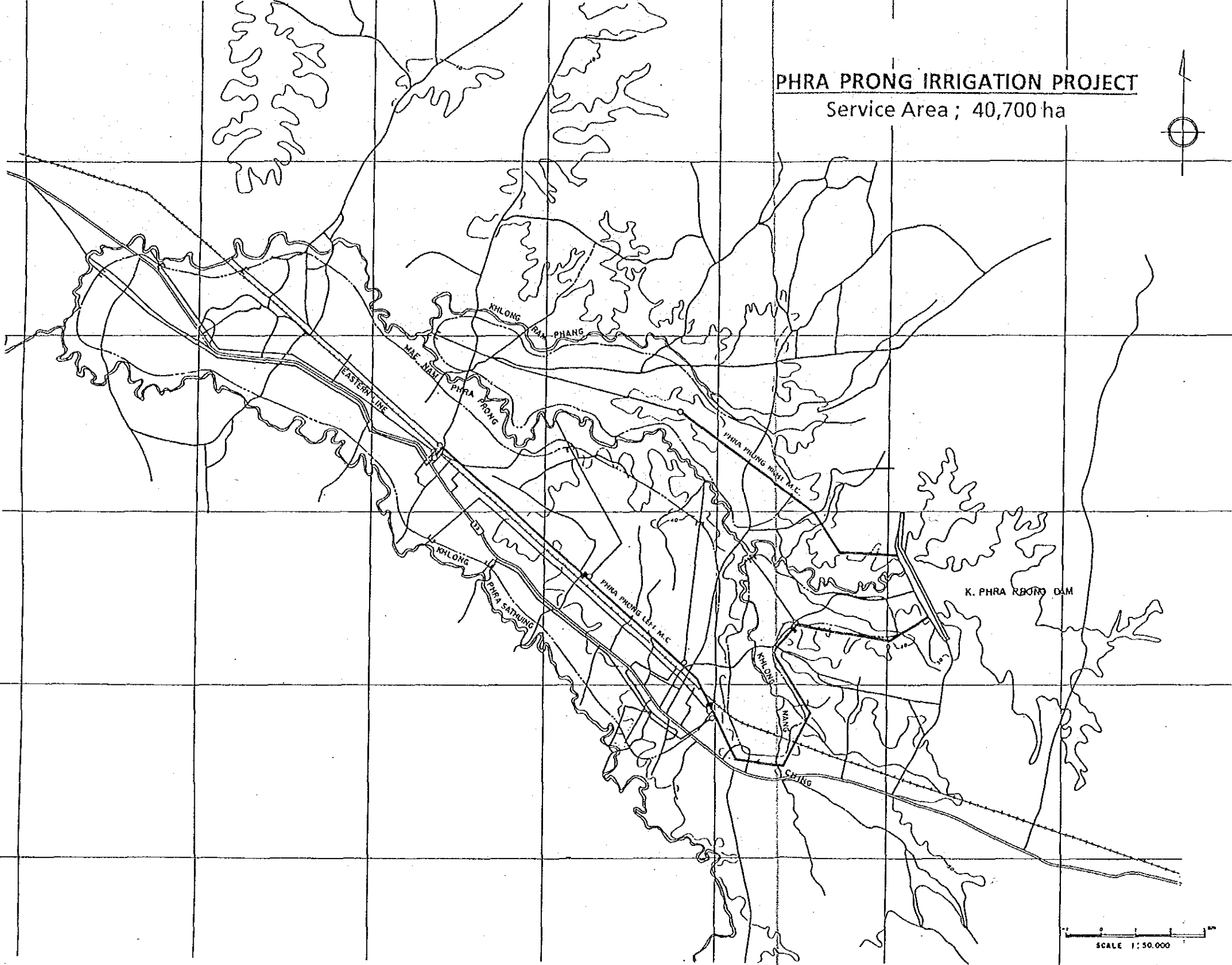
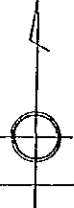

LEGEND

- MAIN CANAL TO BE REHABILITATED
- MAIN CANAL TO BE CONSTRUCTED
- LATERAL CANAL
- HEAD GATE
- END CHECK
- CHECK NEWLY CONSTRUCTED
- EXISTING CHECK
- MAIN ROAD
- LOCAL ROAD
- MAIN RIVER
- BRANCH RIVER
- DAM & RESERVOIR
- DIVERSION DAM
- PROJECT BOUNDARY
- CHANGWAT BOUNDARY
- AMPHOE BOUNDARY
- RAIL WAY

SCALE 1:50,000

FEASIBILITY STUDY
ON
THE THA LAT RIVER BASIN DEVELOPMENT PROJECT

PHRA PRONG IRRIGATION PROJECT

DRAWING NO. M - 5

JAPAN INTERNATIONAL COOPERATION AGENCY

UPPER PHRA PRONG IRRIGATION PROJECT
 Service Area ; 10,940 ha

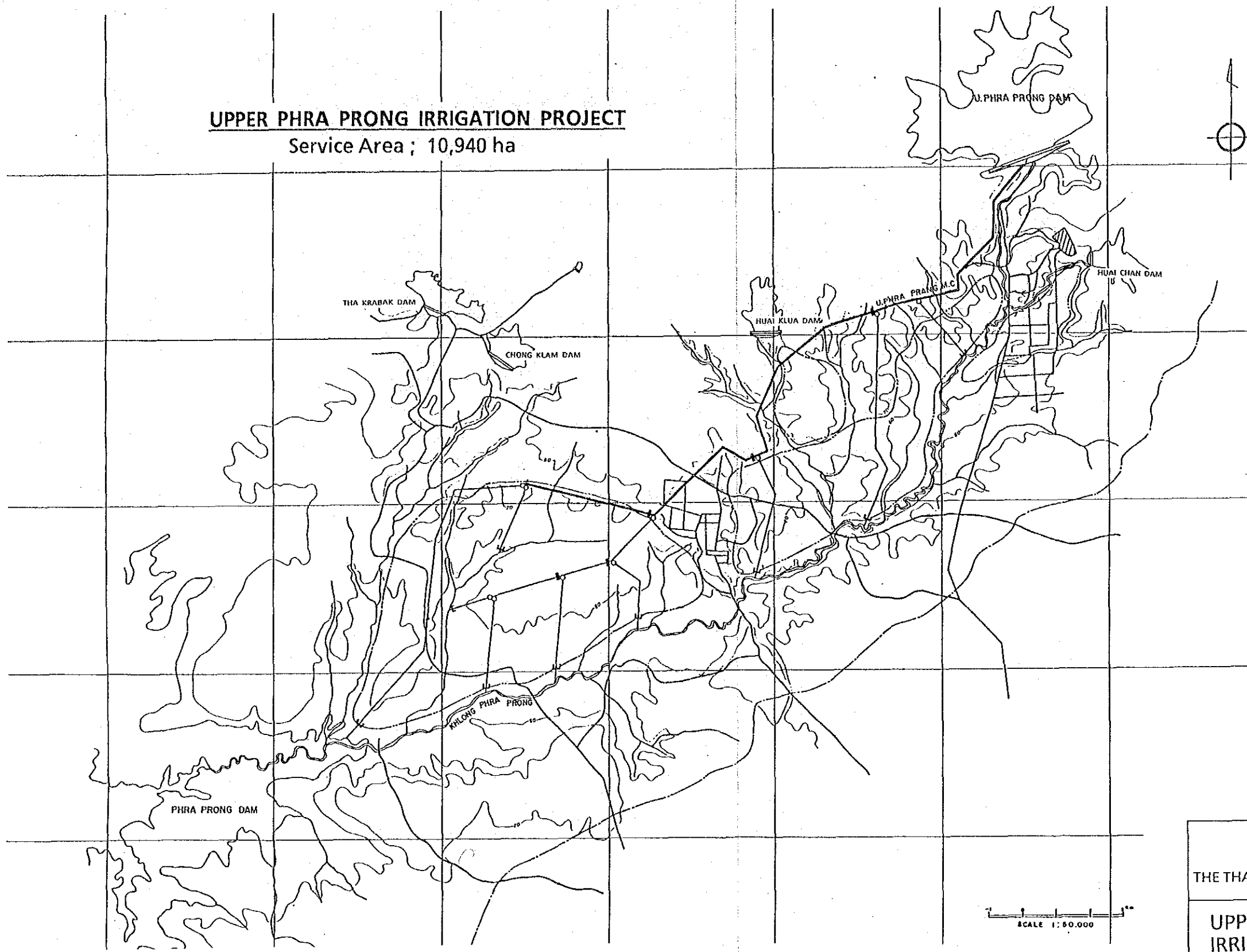

LEGEND

	MAIN CANAL TO BE REHABILITATED
	MAIN CANAL TO BE CONSTRUCTED
	LATERAL CANAL
	HEAD GATE
	END CHECK
	CHECK NEWLY CONSTRUCTED
	EXISTING CHECK
	MAIN ROAD
	LOCAL ROAD
	MAIN RIVER
	BRANCH RIVER
	DAM & RESERVOIR
	DIVERSION DAM
	PROJECT BOUNDARY
	CHANGWAT BOUNDARY
	AMPHOE BOUNDARY
	RAIL WAY

SCALE 1:50,000

FEASIBILITY STUDY
 ON
 THE THA LAT RIVER BASIN DEVELOPMENT PROJECT

**UPPER PHRA PRONG
 IRRIGATION PROJECT**

DRAWING NO. M - 6

JAPAN INTERNATIONAL COOPERATION AGENCY

HUAI SAMONG IRRIGATION PROJECT

Service Area ; 14,300 ha

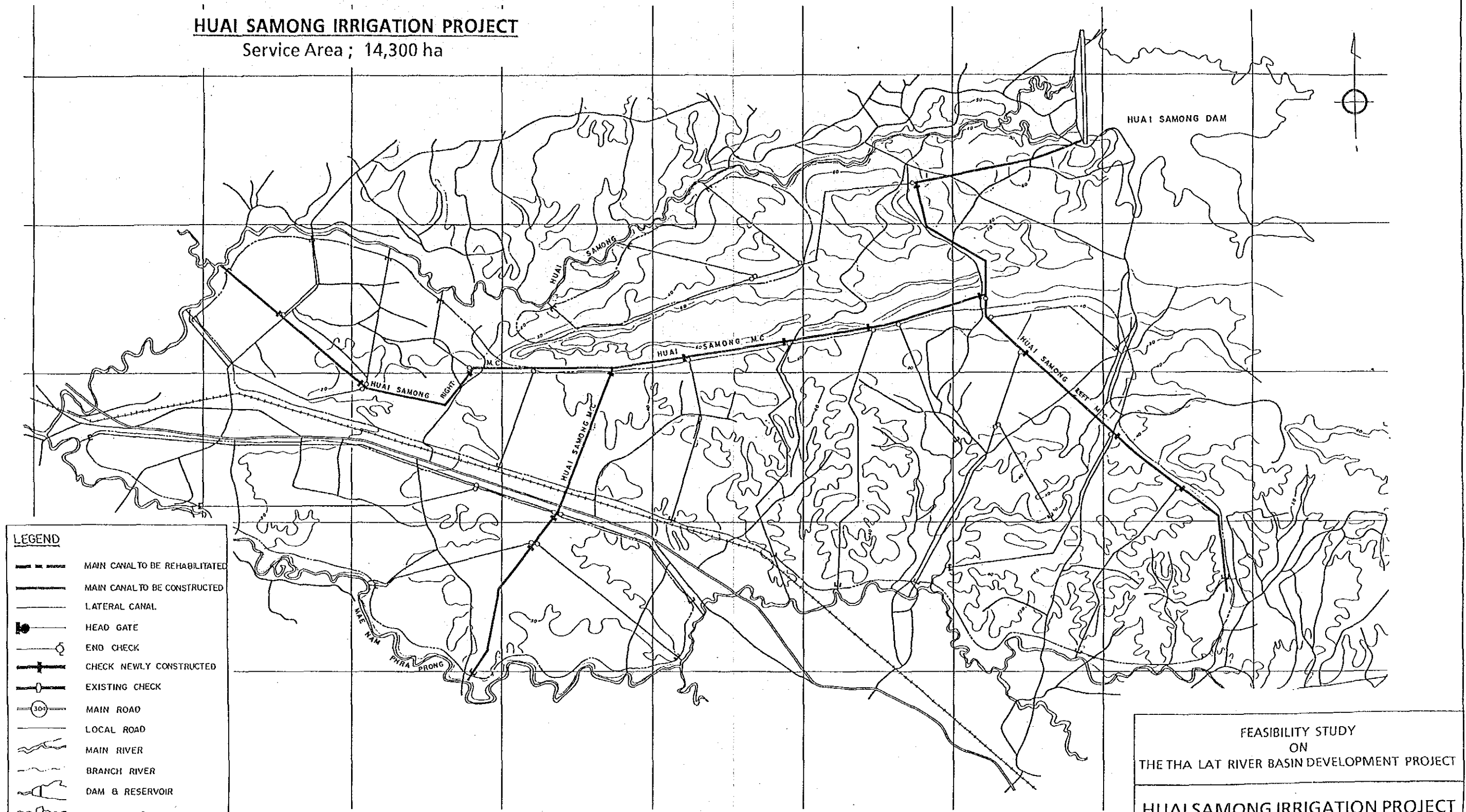

LEGEND	
	MAIN CANAL TO BE REHABILITATED
	MAIN CANAL TO BE CONSTRUCTED
	LATERAL CANAL
	HEAD GATE
	END CHECK
	CHECK NEWLY CONSTRUCTED
	EXISTING CHECK
	MAIN ROAD
	LOCAL ROAD
	MAIN RIVER
	BRANCH RIVER
	DAM & RESERVOIR
	DIVERSION DAM
	PROJECT BOUNDARY
	CHANGWAT BOUNDARY
	AMPHOE BOUNDARY
	RAIL WAY

FEASIBILITY STUDY
ON
THE THA LAT RIVER BASIN DEVELOPMENT PROJECT

HUAI SAMONG IRRIGATION PROJECT

DRAWING NO. M-7

JAPAN INTERNATIONAL COOPERATION AGENCY

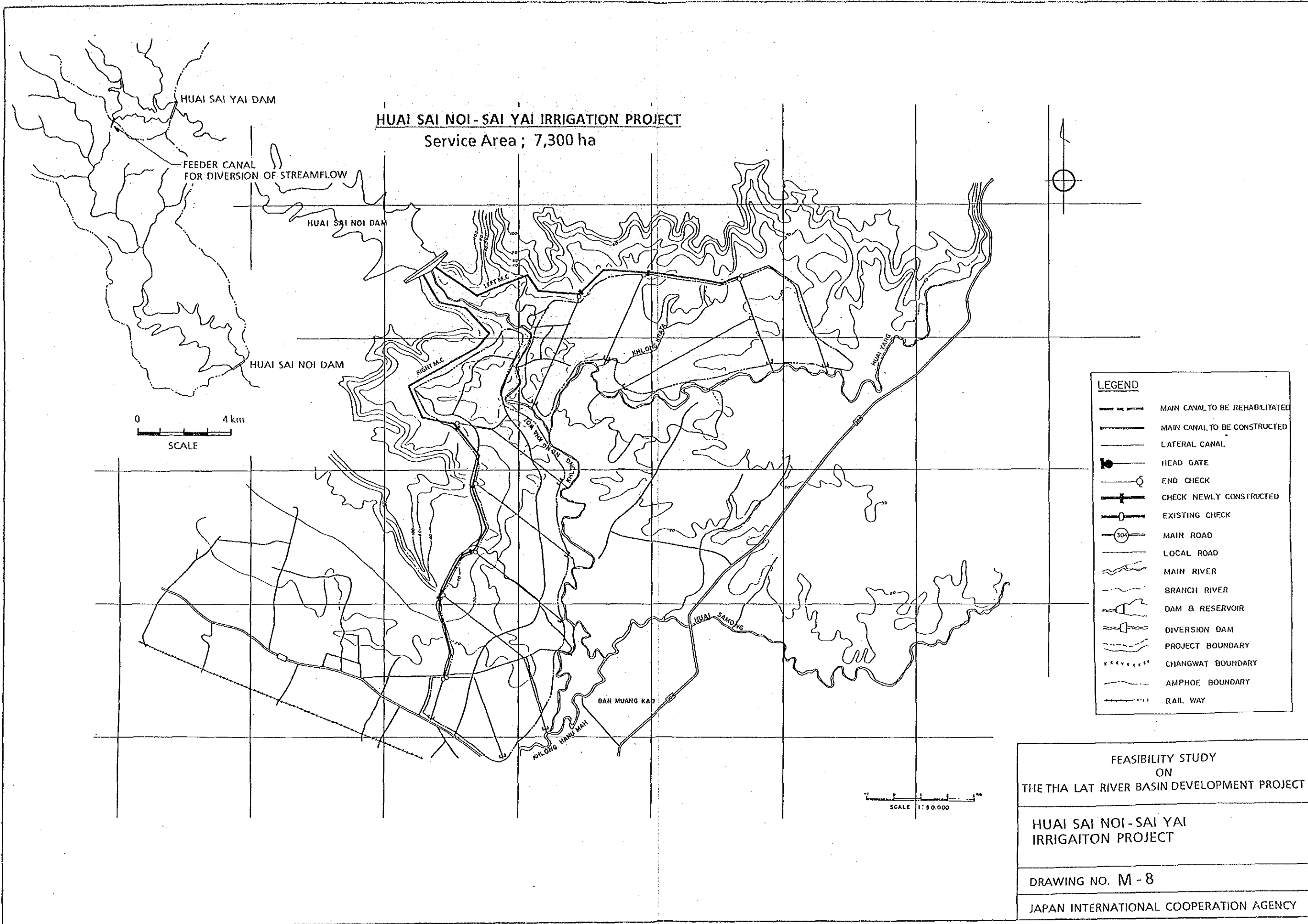

HUAI SAI NOI - SAI YAI IRRIGATION PROJECT
Service Area ; 7,300 ha

0 4 km
SCALE

SCALE 1:50,000

LEGEND	
	MAIN CANAL TO BE REHABILITATED
	MAIN CANAL TO BE CONSTRUCTED
	LATERAL CANAL
	HEAD GATE
	END CHECK
	CHECK NEWLY CONSTRUCTED
	EXISTING CHECK
	MAIN ROAD
	LOCAL ROAD
	MAIN RIVER
	BRANCH RIVER
	DAM & RESERVOIR
	DIVERSION DAM
	PROJECT BOUNDARY
	CHANGWAT BOUNDARY
	AMPHOE BOUNDARY
	RAIL WAY

FEASIBILITY STUDY
ON
THE THA LAT RIVER BASIN DEVELOPMENT PROJECT

HUAI SAI NOI - SAI YAI
IRRIGATION PROJECT

DRAWING NO. M - 8

JAPAN INTERNATIONAL COOPERATION AGENCY

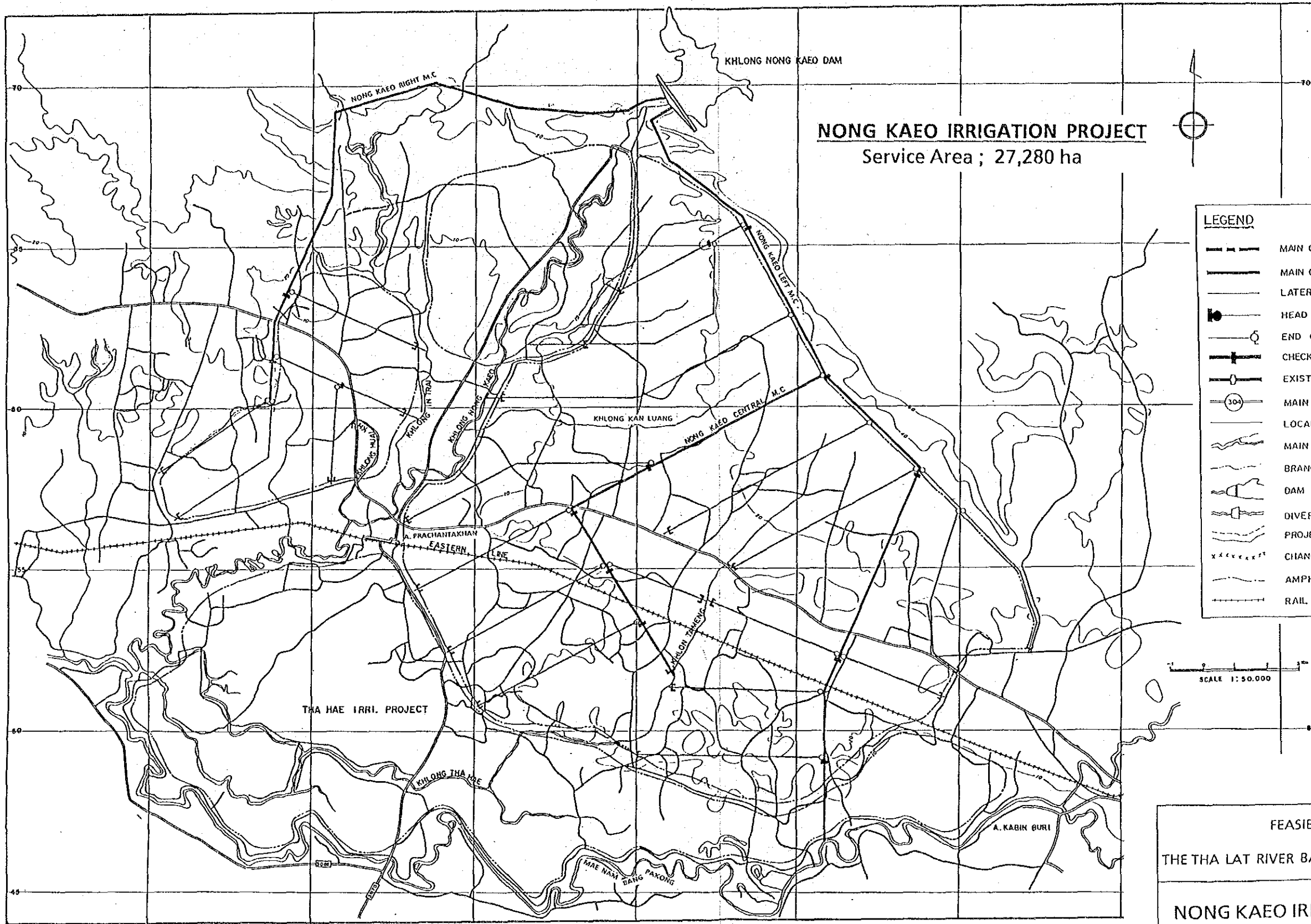

NONG KAEO IRRIGATION PROJECT
 Service Area ; 27,280 ha

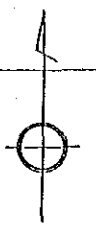

LEGEND	
	MAIN CANAL TO BE REHABILITATED
	MAIN CANAL TO BE CONSTRUCTED
	LATERAL CANAL
	HEAD GATE
	END CHECK
	CHECK NEWLY CONSTRUCTED
	EXISTING CHECK
	MAIN ROAD
	LOCAL ROAD
	MAIN RIVER
	BRANCH RIVER
	DAM & RESERVOIR
	DIVERSION DAM
	PROJECT BOUNDARY
	CHANGWAT BOUNDARY
	AMPHOE BOUNDARY
	RAIL WAY

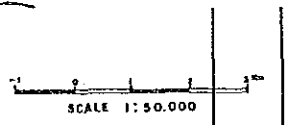

FEASIBILITY STUDY
 ON
 THE THA LAT RIVER BASIN DEVELOPMENT PROJECT

NONG KAEO IRRIGATION PROJECT

DRAWING NO. M - 9

JAPAN INTERNATIONAL COOPERATION AGENCY

THA DAN IRRIGATION PROJECT
Service Area ; 6,940 ha

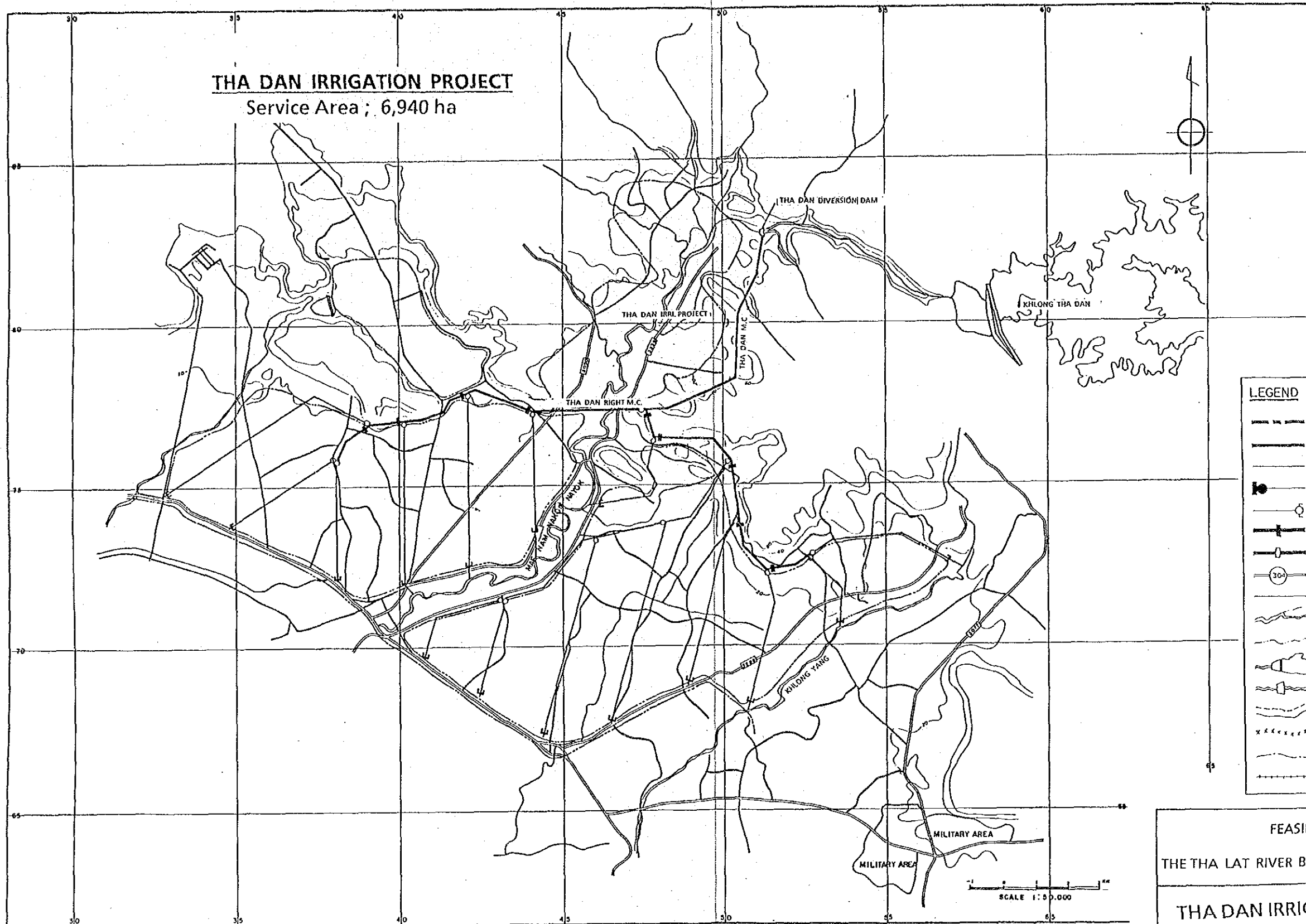

LEGEND

	MAIN CANAL TO BE REHABILITATED
	MAIN CANAL TO BE CONSTRUCTED
	LATERAL CANAL
	HEAD GATE
	END CHECK
	CHECK NEWLY CONSTRUCTED
	EXISTING CHECK
	MAIN ROAD
	LOCAL ROAD
	MAIN RIVER
	BRANCH RIVER
	DAM & RESERVOIR
	DIVERSION DAM
	PROJECT BOUNDARY
	CHANGWAT BOUNDARY
	AMPHOE BOUNDARY
	RAIL WAY

SCALE 1:50,000

FEASIBILITY STUDY
ON
THE THA LAT RIVER BASIN DEVELOPMENT PROJECT

THA DAN IRRIGATION PROJECT

DRAWING NO. M - 10

JAPAN INTERNATIONAL COOPERATION AGENCY

BAN NA IRRIGATION PROJECT
Service Area ; 11,040 ha

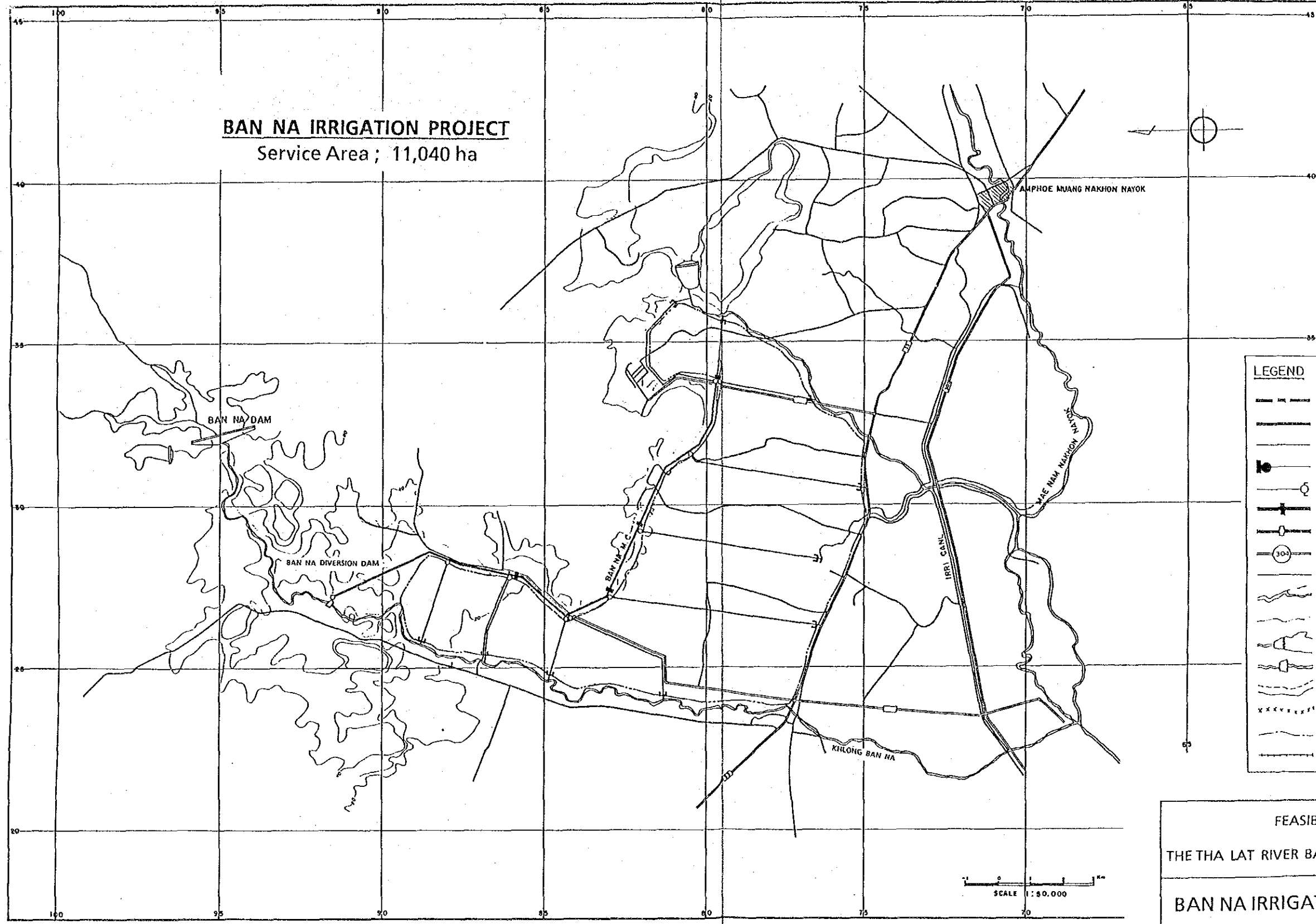

LEGEND

	MAIN CANAL TO BE REHABILITATED
	MAIN CANAL TO BE CONSTRUCTED
	LATERAL CANAL
	HEAD GATE
	END CHECK
	CHECK NEWLY CONSTRUCTED
	EXISTING CHECK
	MAIN ROAD
	LOCAL ROAD
	MAIN RIVER
	BRANCH RIVER
	DAM & RESERVOIR
	DIVERSION DAM
	PROJECT BOUNDARY
	CHANGWAT BOUNDARY
	AMPHOE BOUNDARY
	RAIL WAY

SCALE 1:50,000

FEASIBILITY STUDY
ON
THE THA LAT RIVER BASIN DEVELOPMENT PROJECT

BAN NA IRRIGATION PROJECT

DRAWING NO. M-11

JAPAN INTERNATIONAL COOPERATION AGENCY

LAM PHRAYA THAN IRRIGATION PROJECT
 Service Area ; 7,500 ha

LAM PHRAYA THAN DAM

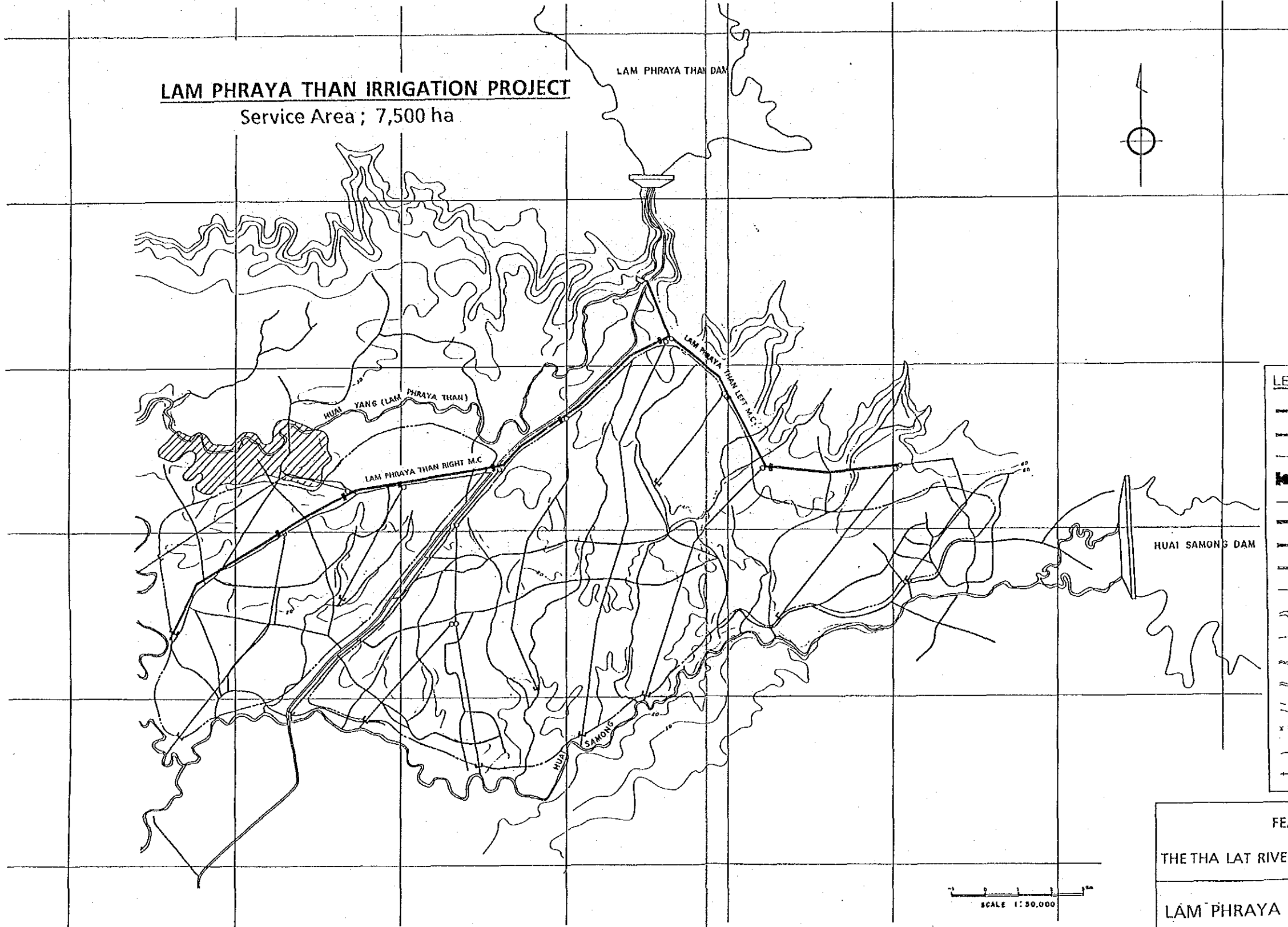

LEGEND	
	MAIN CANAL TO BE REHABILITATED
	MAIN CANAL TO BE CONSTRUCTED
	LATERAL CANAL
	HEAD GATE
	END CHECK
	CHECK NEWLY CONSTRUCTED
	EXISTING CHECK
	MAIN ROAD
	LOCAL ROAD
	MAIN RIVER
	BRANCH RIVER
	DAM & RESERVOIR
	DIVERSION DAM
	PROJECT BOUNDARY
	CHANGWAT BOUNDARY
	AMPHOE BOUNDARY
	RAIL WAY

FEASIBILITY STUDY
 ON
 THE THA LAT RIVER BASIN DEVELOPMENT PROJECT

LAM PHRAYA THAN IRRIGATION PROJECT

DRAWING NO. M - 12

JAPAN INTERNATIONAL COOPERATION AGENCY

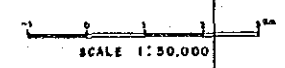

FEASIBILITY STUDY

THA LAT RIVER BASIN DEVELOPMENT PROJECT

SCALE 1 : 250,000

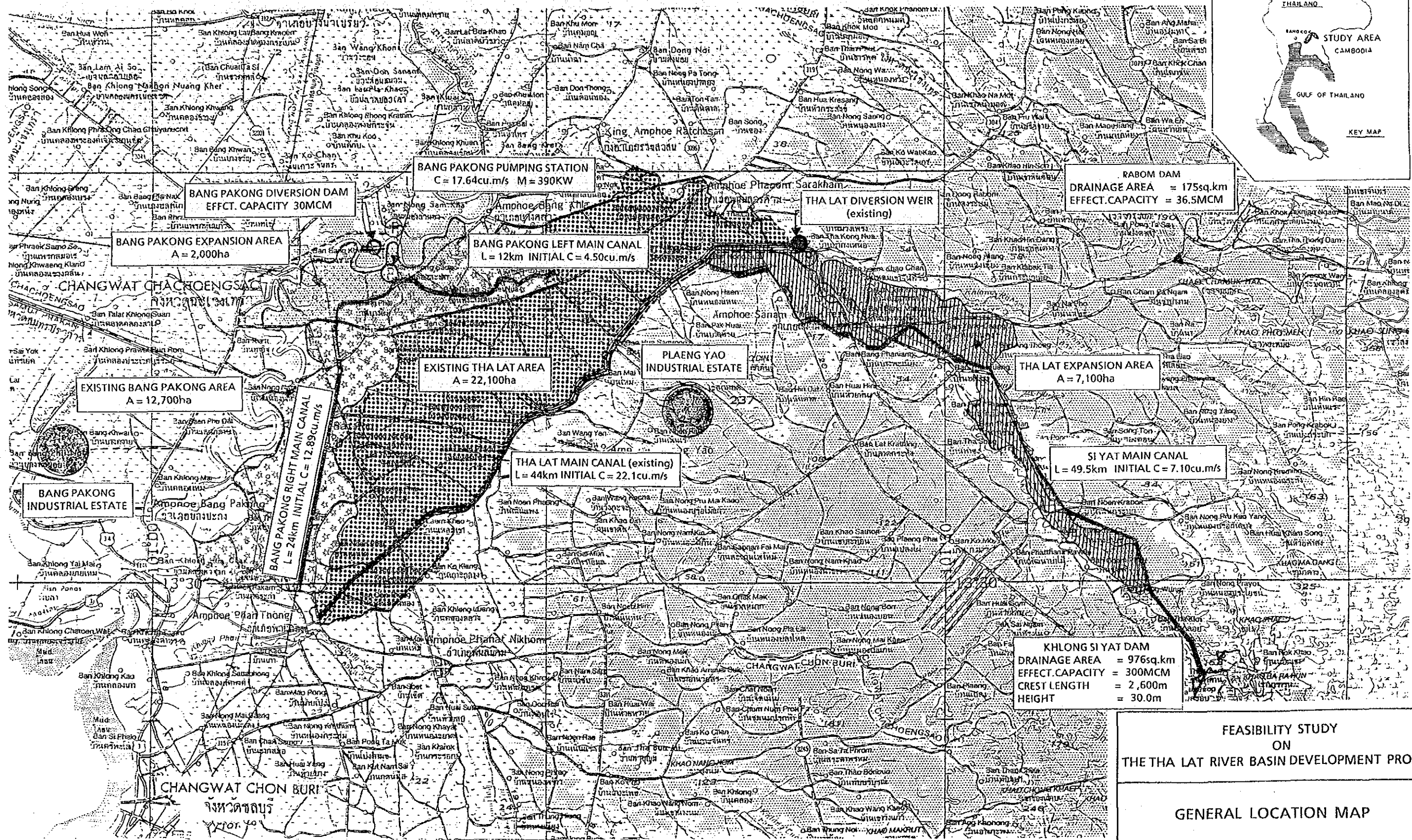
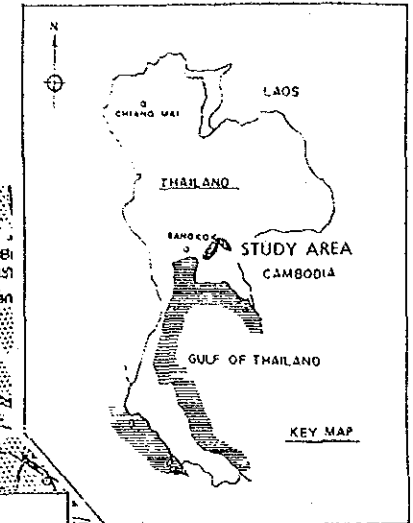

FEASIBILITY STUDY
ON
THE THA LAT RIVER BASIN DEVELOPMENT PROJECT

GENERAL LOCATION MAP

DRAWING NO. F - 1

JAPAN INTERNATIONAL COOPERATION AGENCY

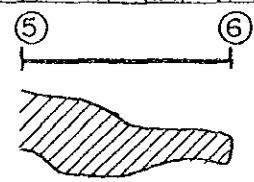
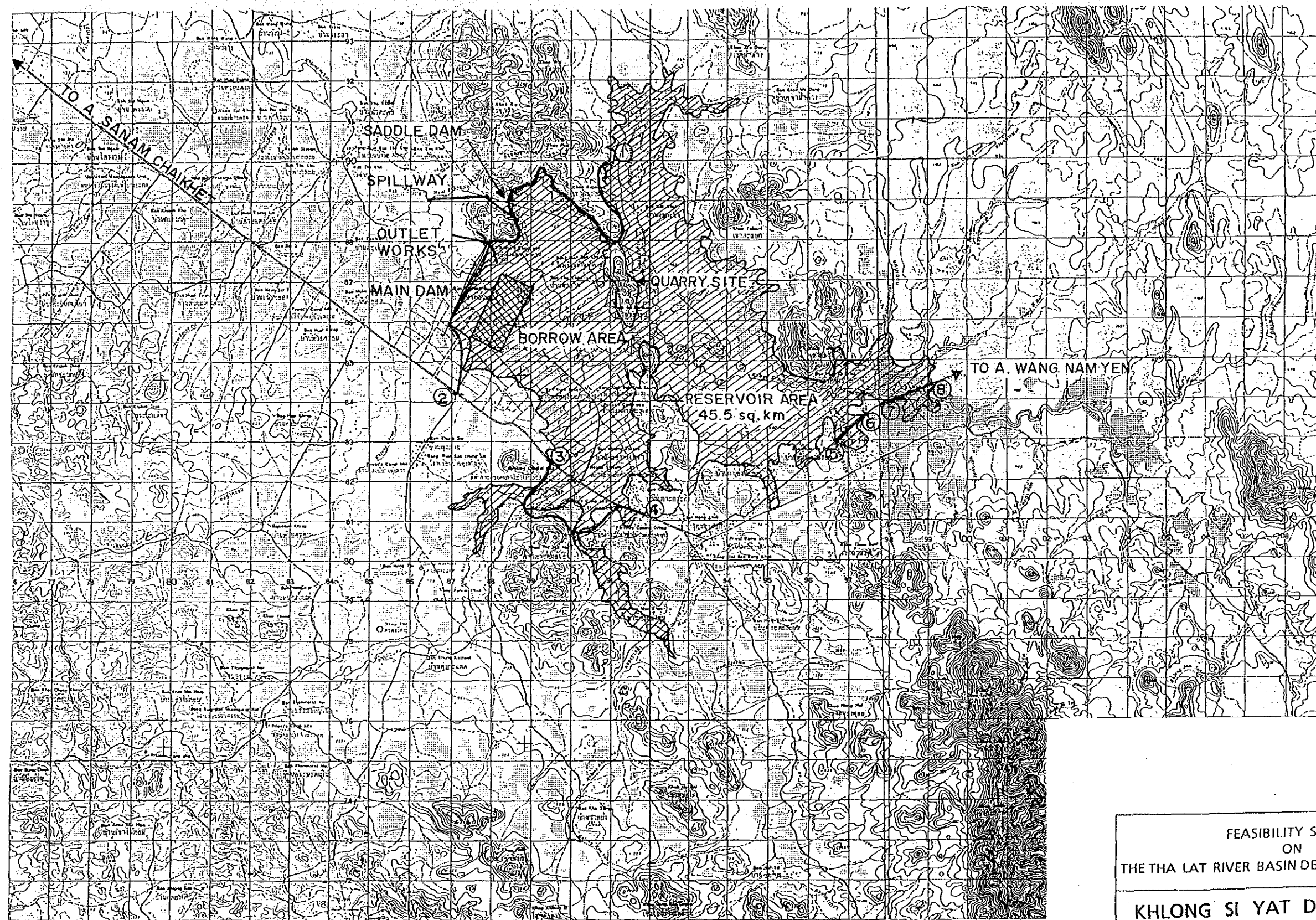

ROAD
 RESERVOIR AREA
 AT NORMAL WATER LEVEL EL. 63.1m

LOCATION MAP
 SCALE 1: 100,000

FEASIBILITY STUDY
 ON
 THE THA LAT RIVER BASIN DEVELOPMENT PROJECT

KHLONG SI YAT DAM
 LOCATION MAP

DRAWING NO. F-2

JAPAN INTERNATIONAL COOPERATION AGENCY

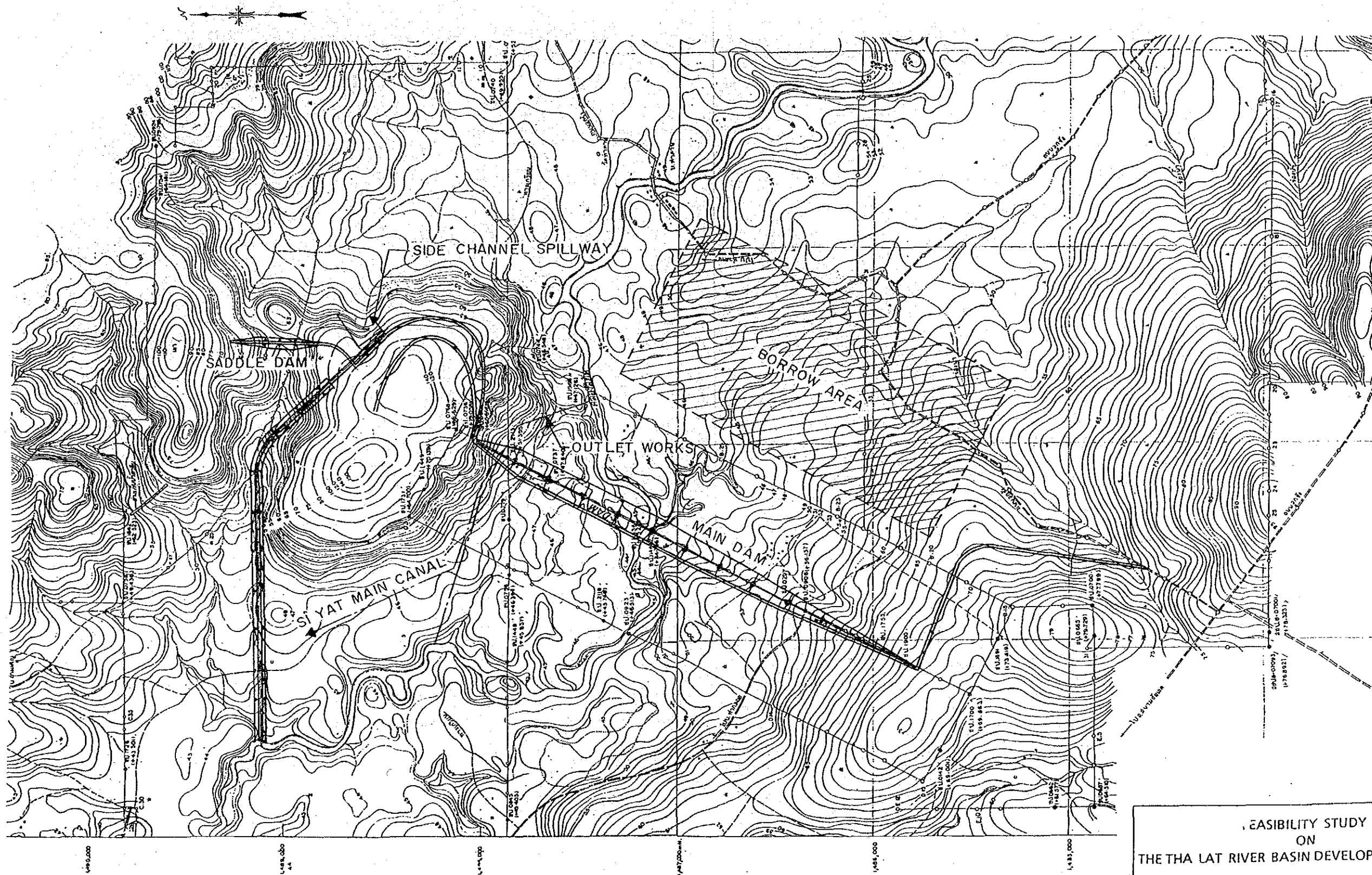

SITE PLAN
SCALE 1:20,000

EASIBILITY STUDY ON THE THA LAT RIVER BASIN DEVELOPMENT PROJECT
KHLONG SI YAT DAM SITE PLAN
DRAWING NO. F-3
JAPAN INTERNATIONAL COOPERATION AGENCY

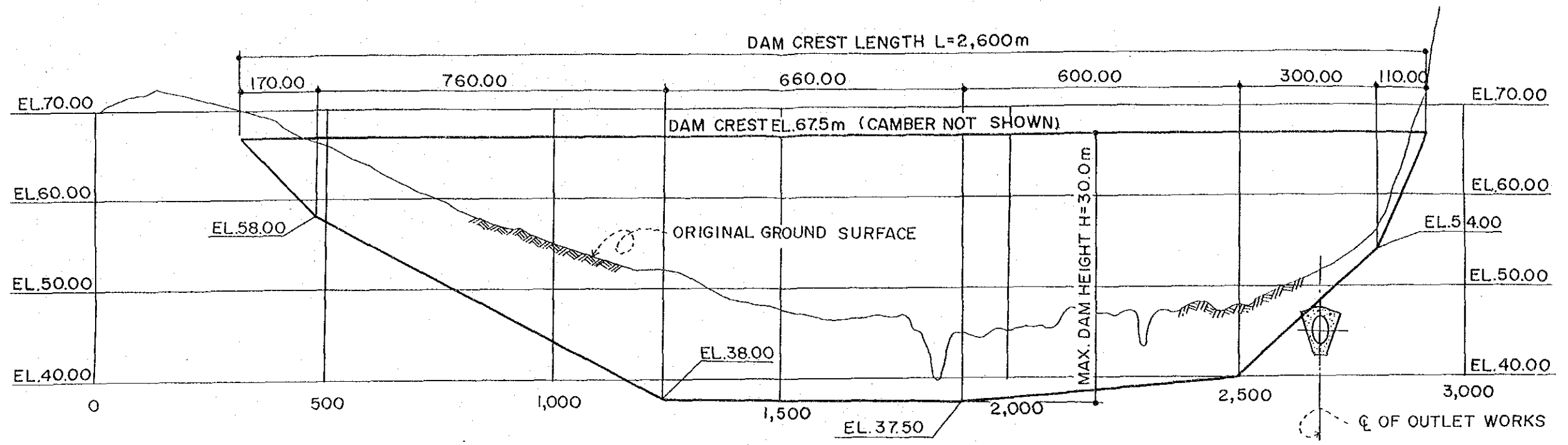

PROFILE ON ϕ CREST OF MAIN DAM
 SCALE H=1:10,000
 V=1:500

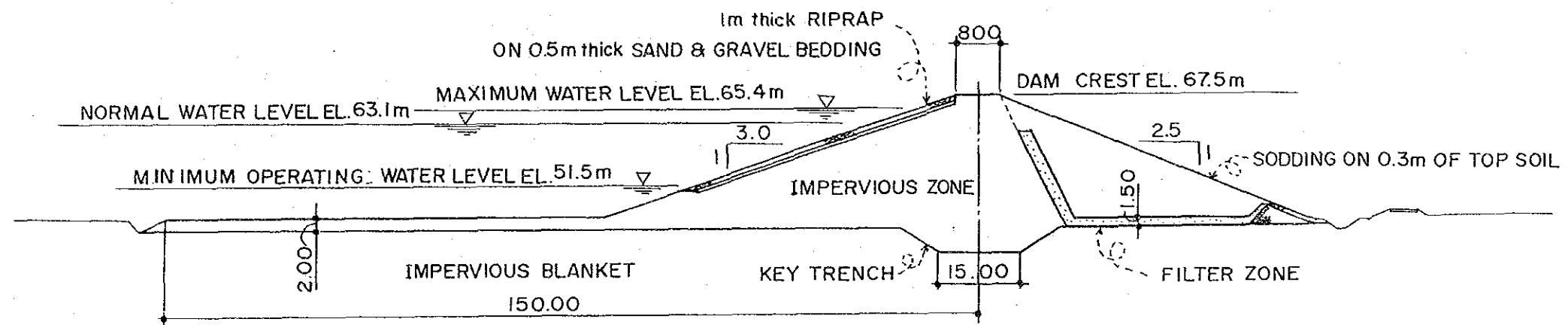

TYPICAL CROSS SECTION OF DAM
 SCALE 1:1,000

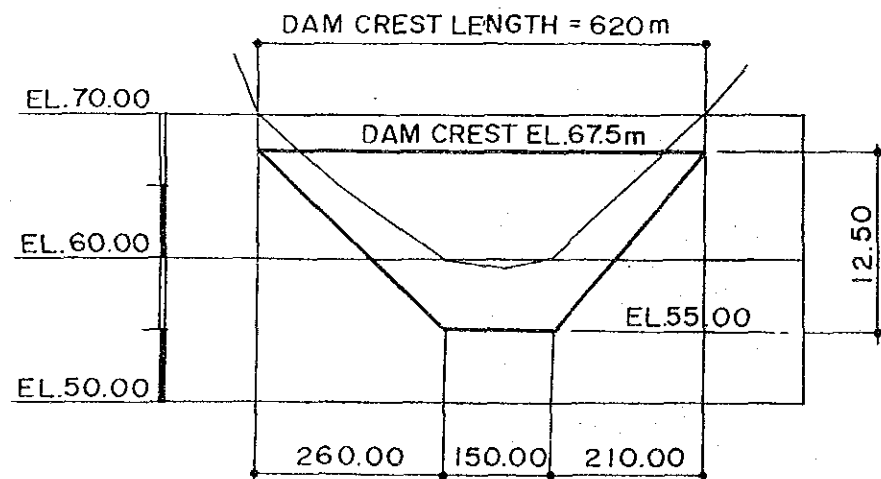

PROFILE ON ϕ CREST OF SADDLE DAM
 SCALE H=1:10,000
 V=1:500

FEASIBILITY STUDY ON THE THA LAT RIVER BASIN DEVELOPMENT PROJECT
KHLONG SI YAT DAM MAIN AND SADDLE DAMS
DRAWING NO. F-4
JAPAN INTERNATIONAL COOPERATION AGENCY

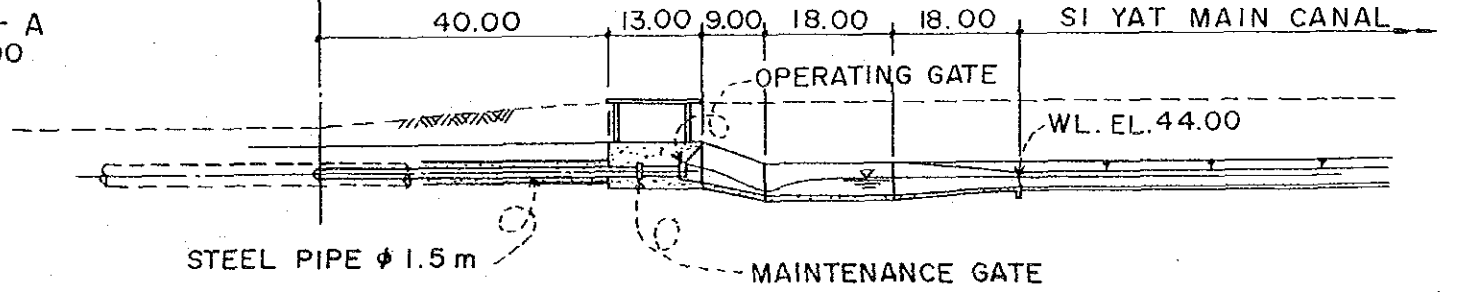
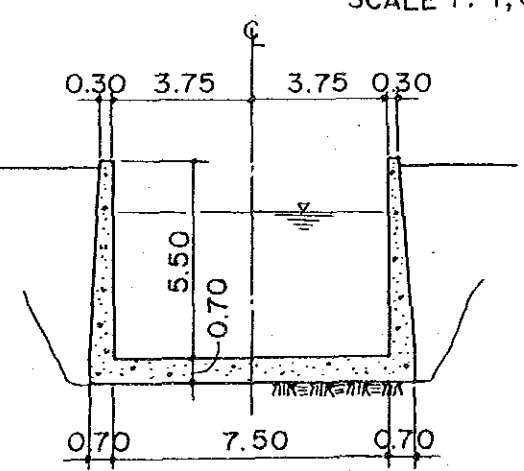
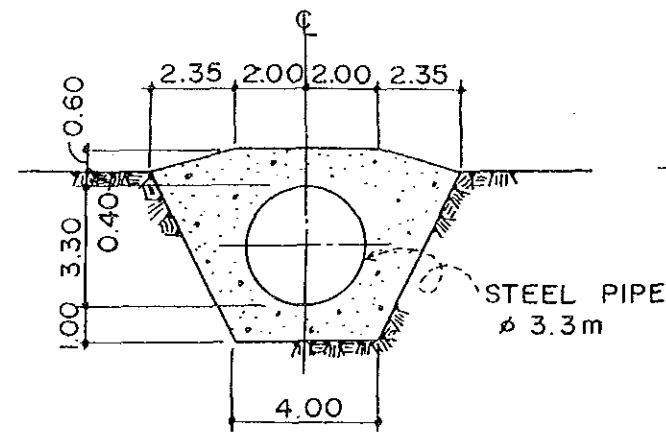
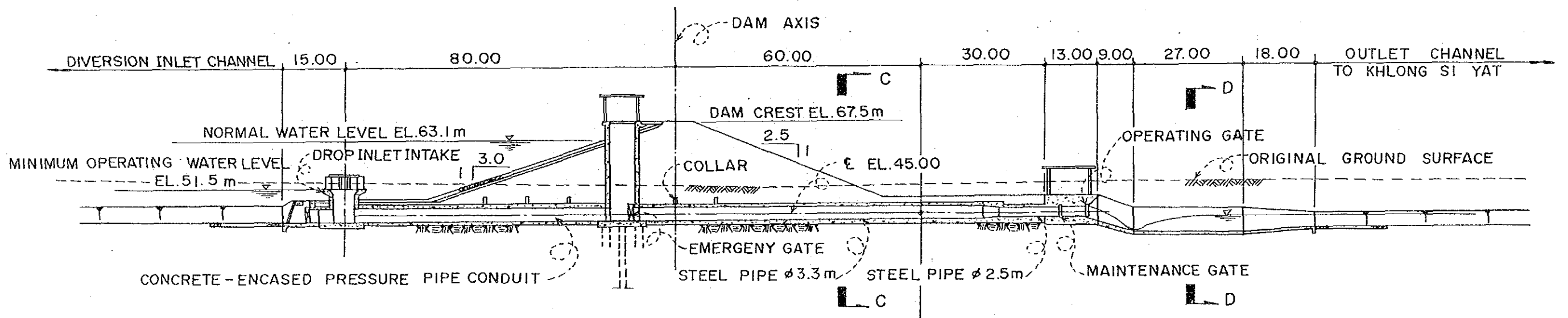
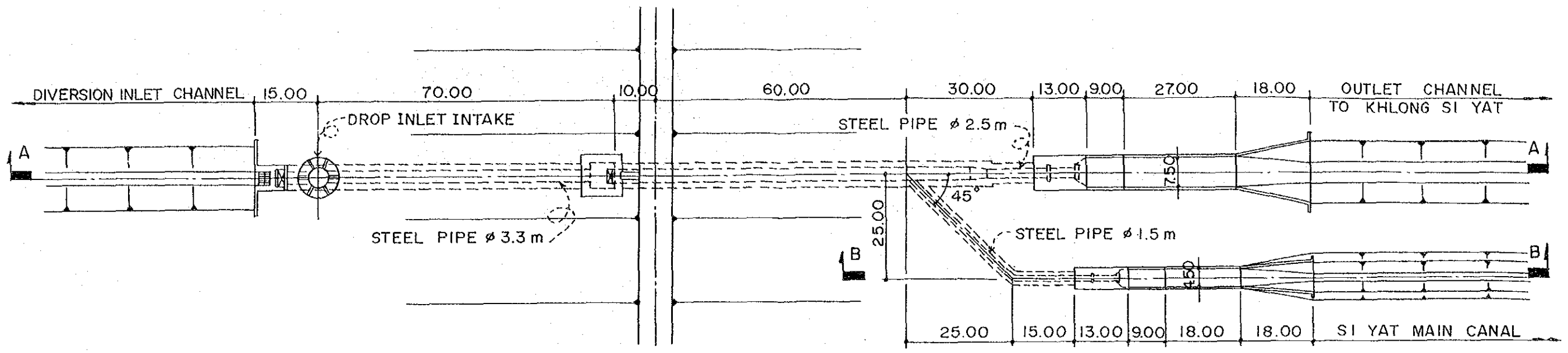

ALL DIMENSIONS ARE SHOWN IN METERS.

FEASIBILITY STUDY ON THE THA LAT RIVER BASIN DEVELOPMENT PROJECT
KHLONG SI YAT DAM OUTLET WORKS
DRAWING NO. F-5
JAPAN INTERNATIONAL COOPERATION AGENCY

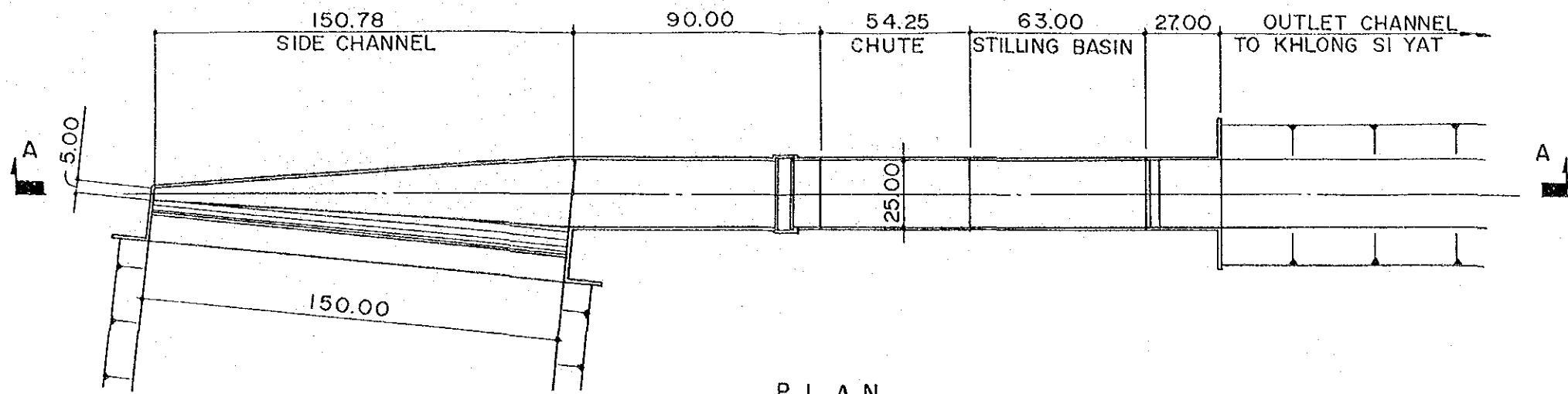

P L A N
SCALE 1:2,000

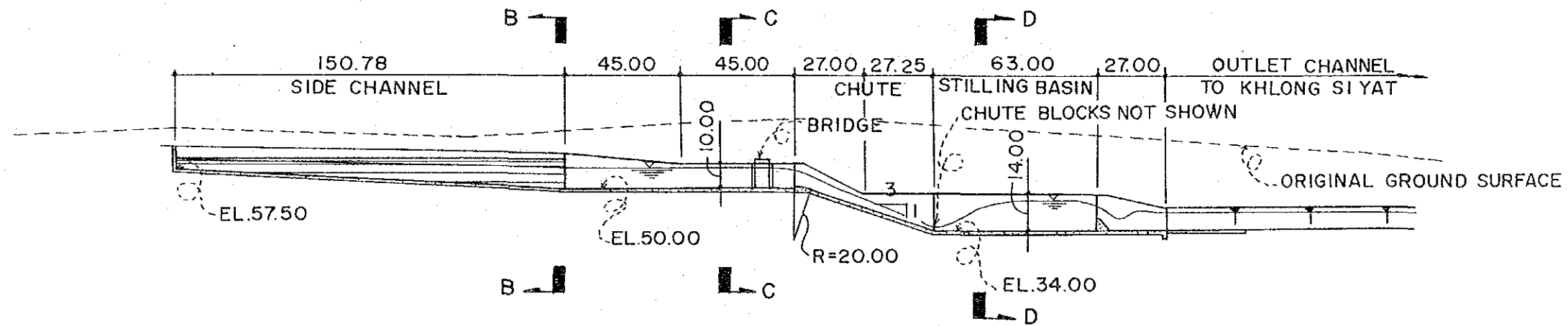

SECTION A - A
SCALE 1:2,000

ALL DIMENSIONS ARE SHOWN IN METERS.

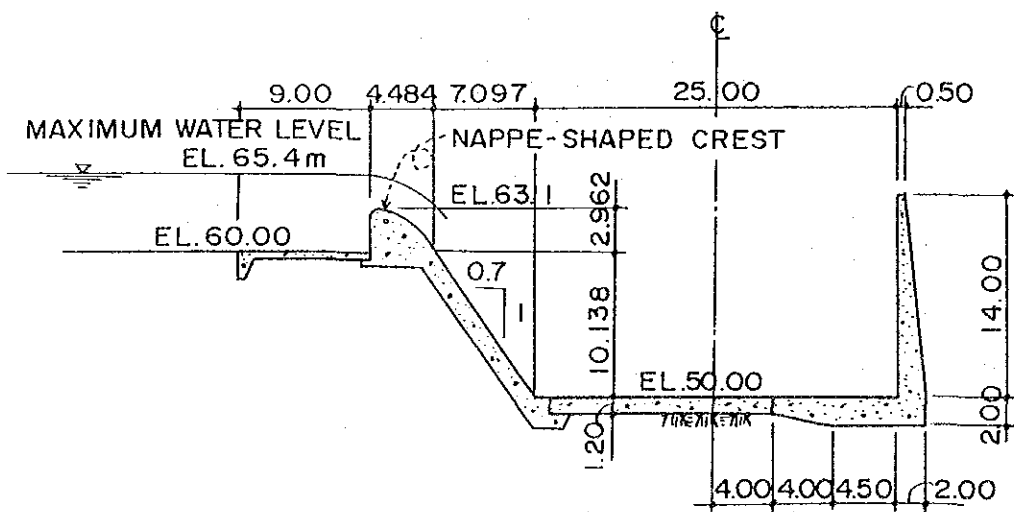

SECTION B - B
SCALE 1:500

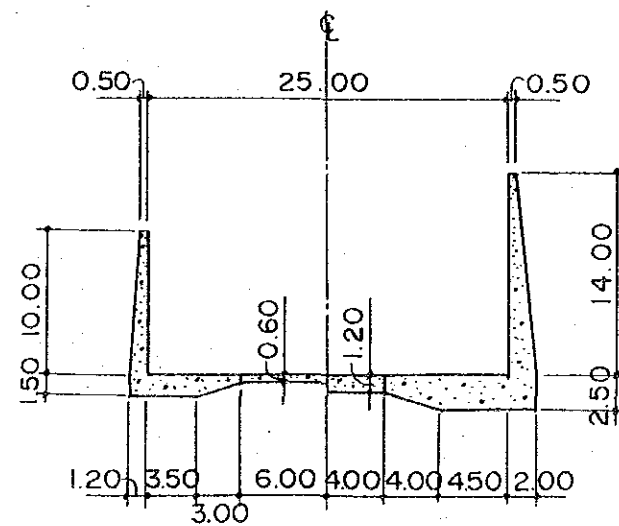

SECTION C - C
SCALE 1:500

SECTION D - D
SCALE 1:500

FEASIBILITY STUDY ON THE THA LAT RIVER BASIN DEVELOPMENT PROJECT
KHLONG SI YAT DAM SPILLWAY
DRAWING NO. F-6
JAPAN INTERNATIONAL COOPERATION AGENCY

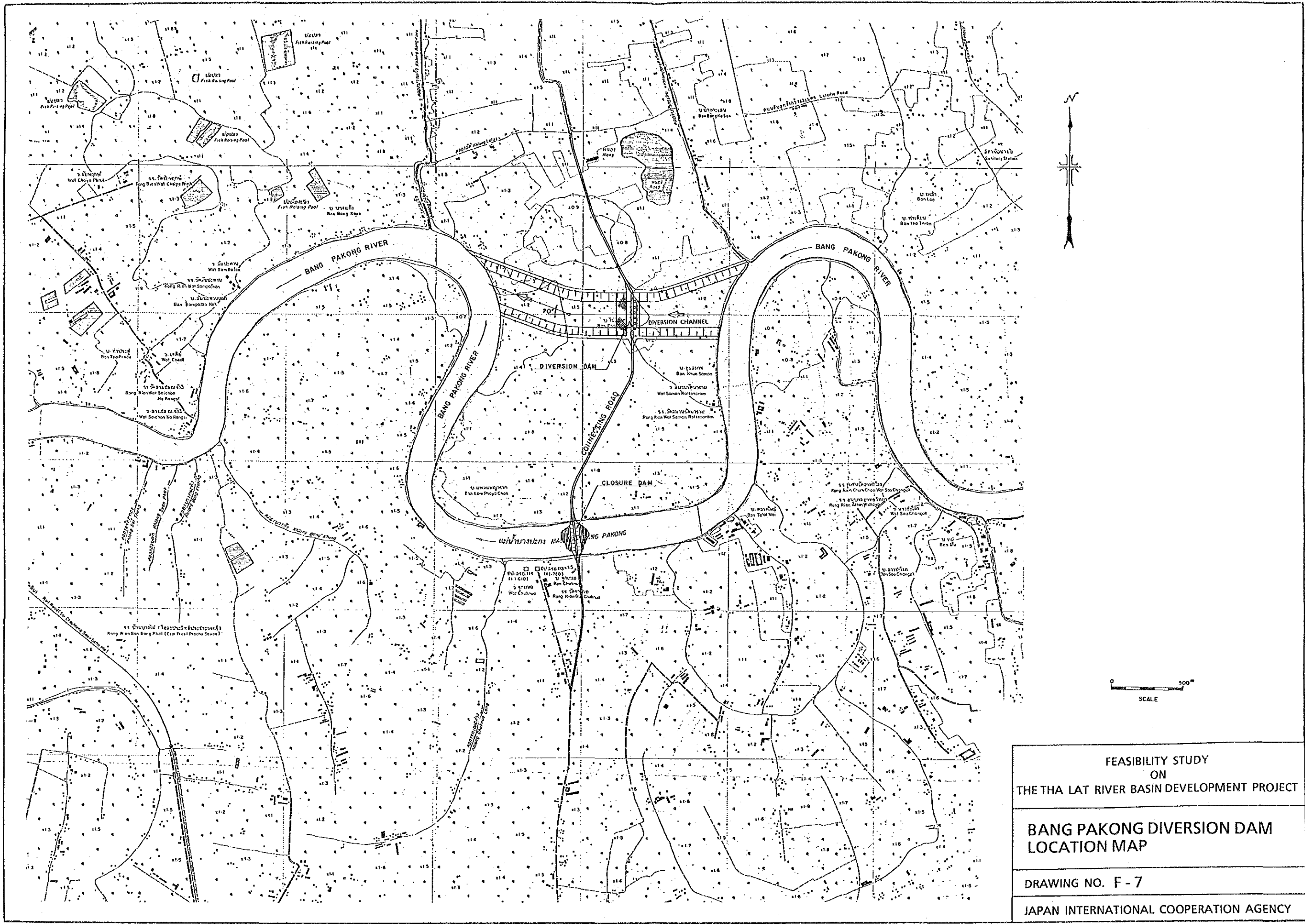

FEASIBILITY STUDY
ON
THE THA LAT RIVER BASIN DEVELOPMENT PROJECT

**BANG PAKONG DIVERSION DAM
LOCATION MAP**

DRAWING NO. F-7

JAPAN INTERNATIONAL COOPERATION AGENCY

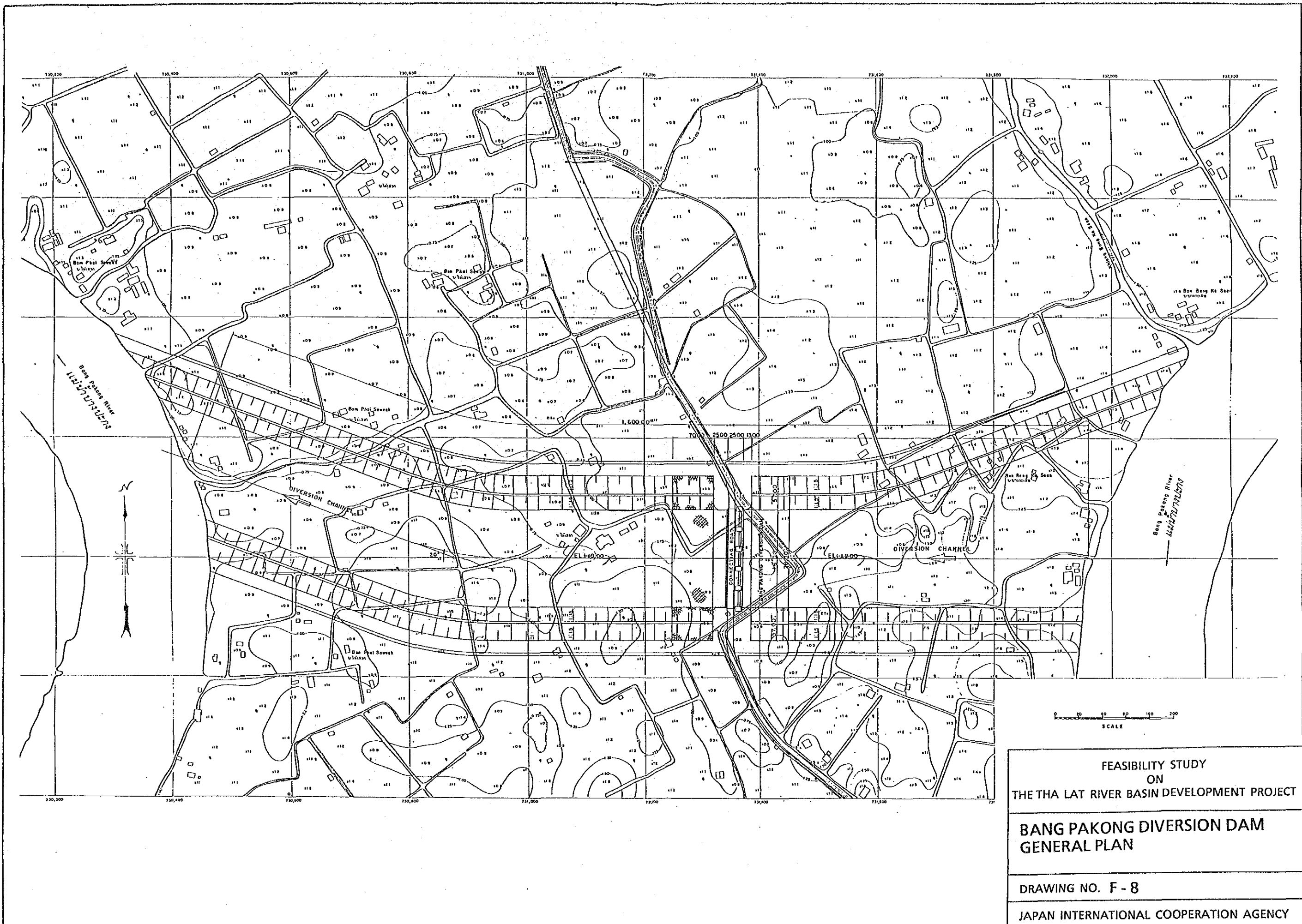

FEASIBILITY STUDY
ON
THE THA LAT RIVER BASIN DEVELOPMENT PROJECT

**BANG PAKONG DIVERSION DAM
GENERAL PLAN**

DRAWING NO. F - 8

JAPAN INTERNATIONAL COOPERATION AGENCY

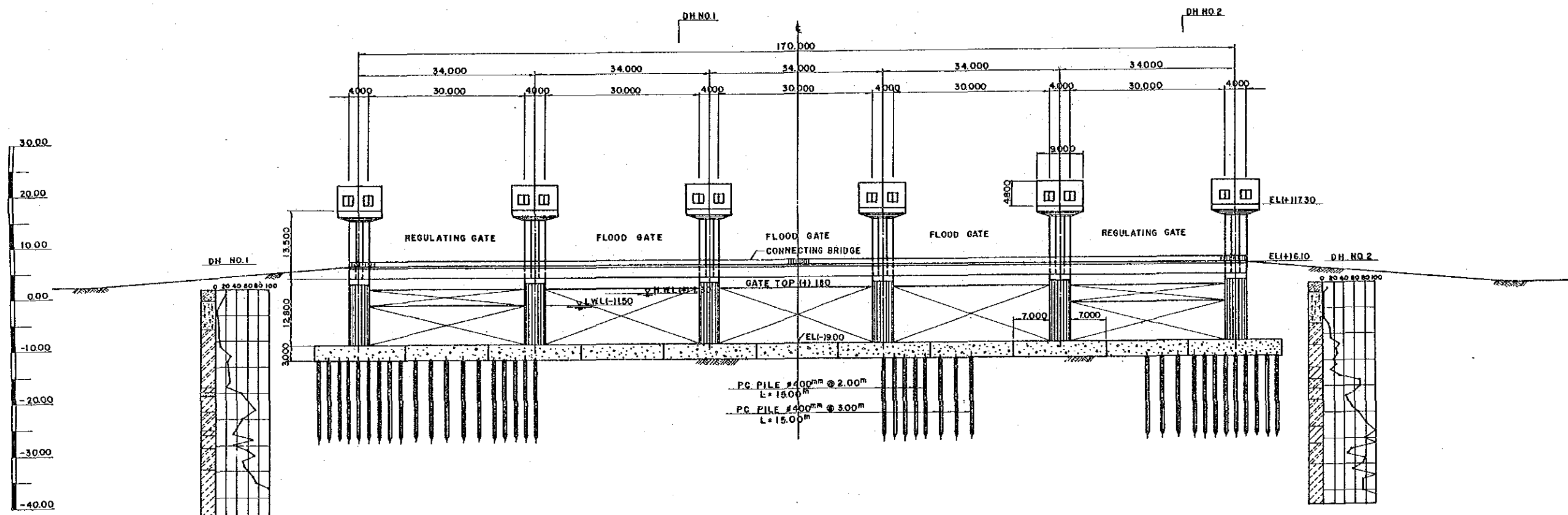

GENERAL ELEVATION OF DIVERSION DAM

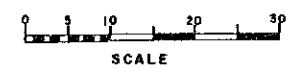

FEASIBILITY STUDY ON THE THA LAT RIVER BASIN DEVELOPMENT PROJECT
BANG PAKONG DIVERSION DAM ELEVATION
DRAWING NO. F - 9
JAPAN INTERNATIONAL COOPERATION AGENCY

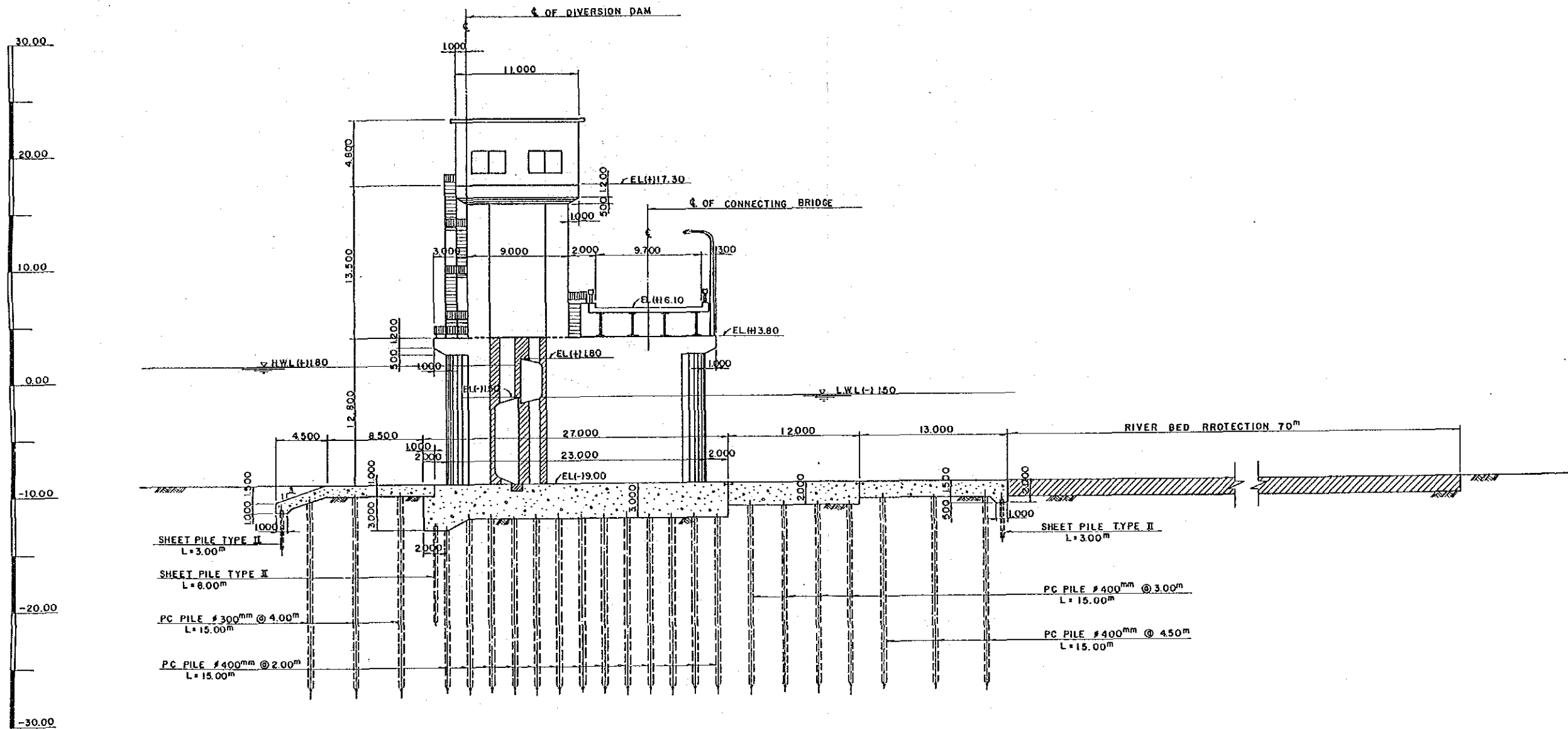

TYPICAL SECTION OF DIVERSION DAM

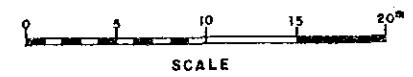

FEASIBILITY STUDY
ON
THE THA LAT RIVER BASIN DEVELOPMENT PROJECT

**BANG PAKONG DIVERSION DAM
TYPICAL SECTION**

DRAWING NO. F-10

JAPAN INTERNATIONAL COOPERATION AGENCY

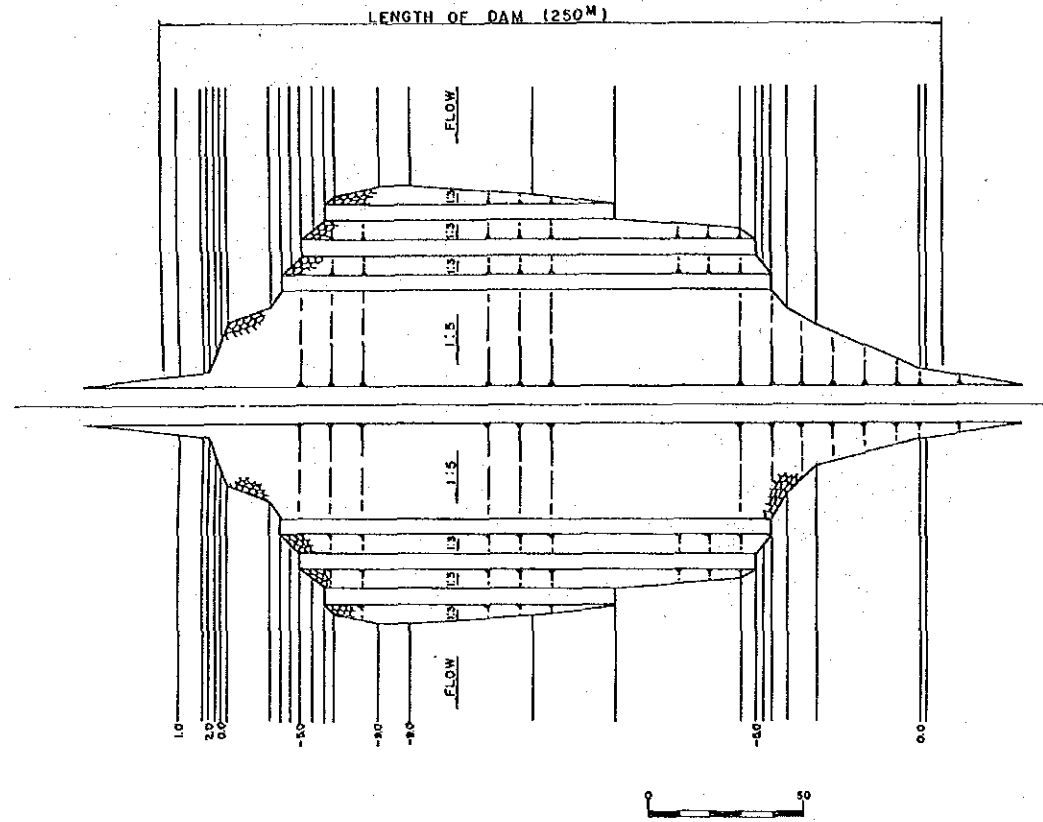

P L A N

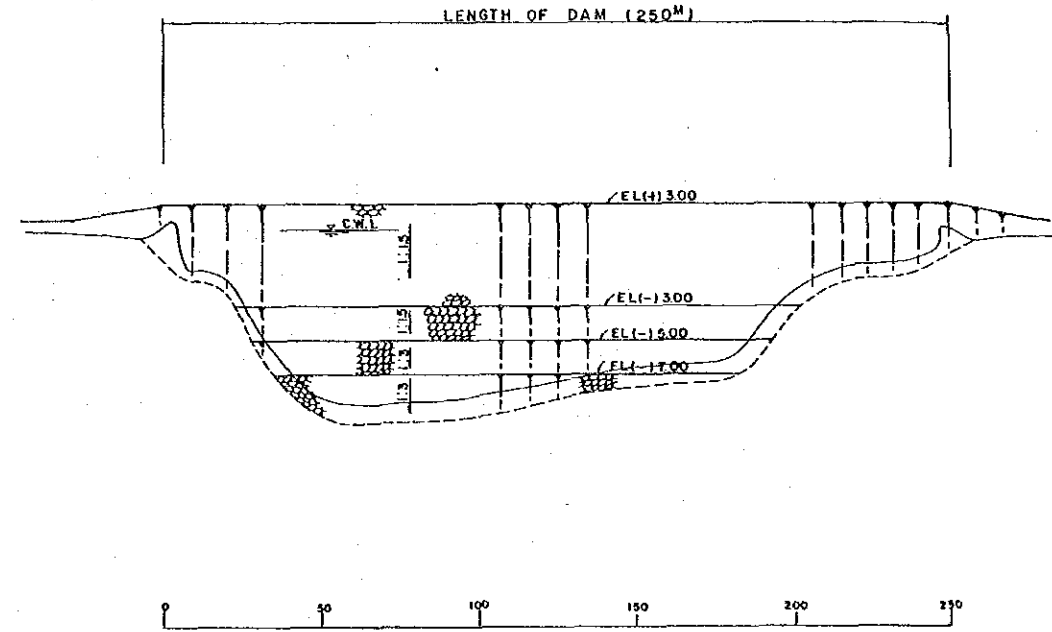

E L E V A T I O N

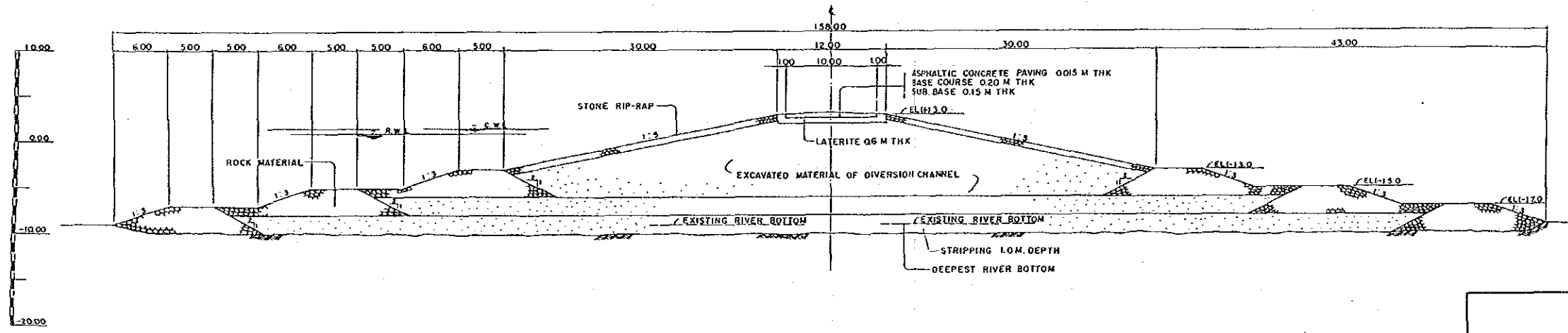

T Y P I C A L S E C T I O N



<p>FEASIBILITY STUDY ON THE THA LAT RIVER BASIN DEVELOPMENT PROJECT</p>
<p>BANG PAKONG DIVERSION DAM CLOSURE DAM PLAN AND SECTION</p>
<p>DRAWING NO. F - 11</p>
<p>JAPAN INTERNATIONAL COOPERATION AGENCY</p>

THA LAT RIVER BASIN DEVELOPMENT PROJECT

THA LAT IRRIGATION AND BANG PAKONG LEFT BANK AREA

BANG PAKONG LEFT BANK IRRIGATION PROJECT		
BANG PAKONG LEFT BANK EXPANSION AREA		
HEAD GATE	SERVICE AREA	DISCHARGE
O-1	390 ha	0.47 m ³ /s
O-2	940	1.15
O-3	670	0.80
TOTAL	2,000	2.40
BANG PAKONG LEFT BANK AREA		
HEAD GATE	SERVICE AREA	DISCHARGE
L-1	650 ha	0.76 m ³ /s
L-2	580	0.69
L-3	240	0.29
L-4	340	0.41
L-5	340	0.41
L-6	850	1.05
L-7	550	0.64
SUB-TOTAL	3,570	4.28
R-1	850	1.02
R-2	590	0.71
R-3	1,120	1.35
R-4	510	0.61
R-5	350	0.42
R-6	1,240	1.49
R-7	1,300	1.56
R-8	670	0.80
M.C.	2,500	3.00
SUB-TOTAL	9,150	10.95
TOTAL	12,700	17.64

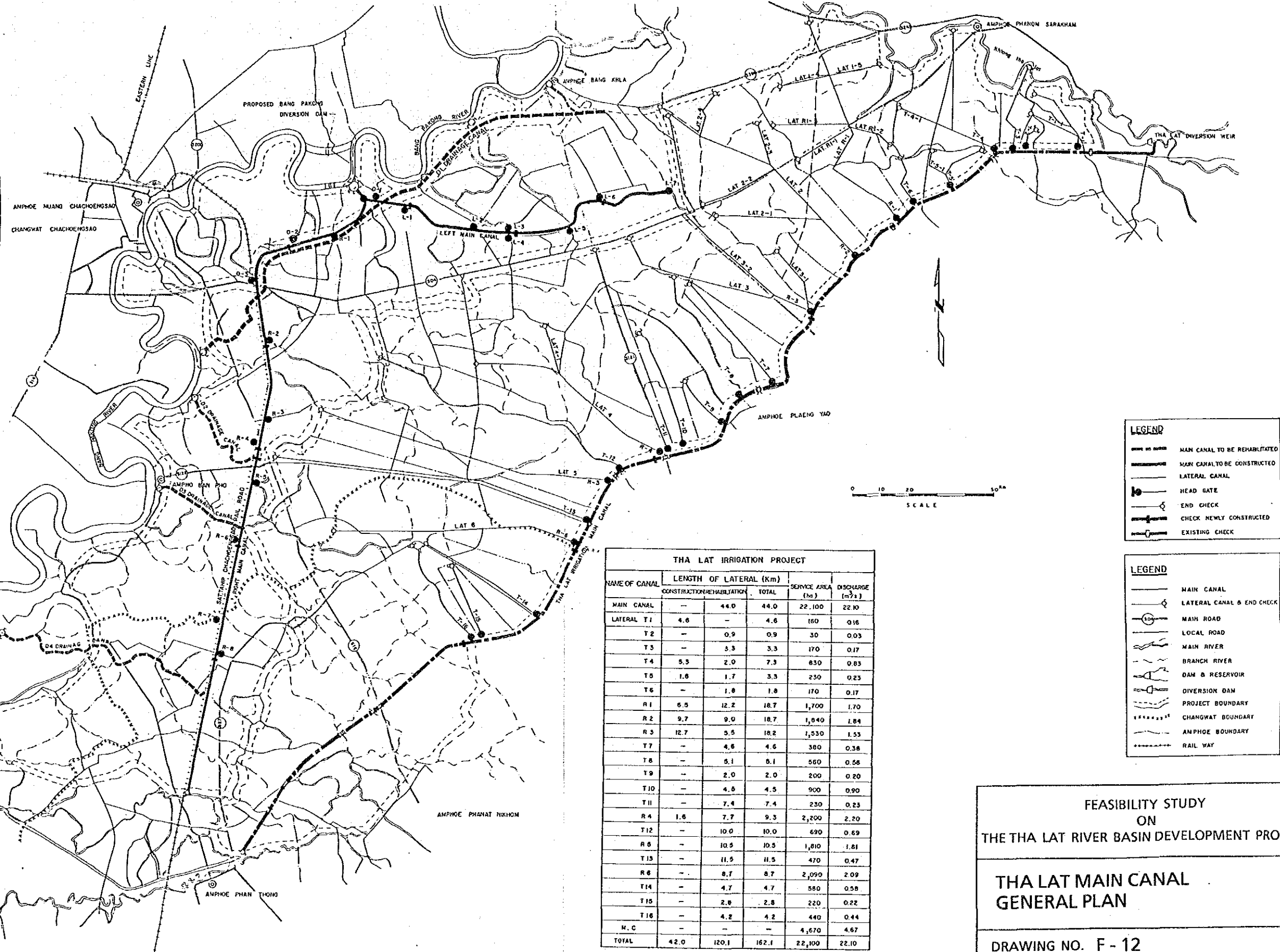

LEGEND	
	MAIN CANAL TO BE REHABILITATED
	MAIN CANAL TO BE CONSTRUCTED
	LATERAL CANAL
	HEAD GATE
	END CHECK
	CHECK NEWLY CONSTRUCTED
	EXISTING CHECK

THA LAT IRRIGATION PROJECT					
NAME OF CANAL	LENGTH OF LATERAL (K.m)		TOTAL	SERVICE AREA (ha)	DISCHARGE (m ³ /s)
	CONSTRUCTION	REHABILITATION			
MAIN CANAL	-	44.0	44.0	22,100	22.10
LATERAL T1	4.6	-	4.6	160	0.16
T2	-	0.9	0.9	30	0.03
T3	-	3.3	3.3	170	0.17
T4	5.3	2.0	7.3	850	0.85
T5	1.6	1.7	3.3	250	0.25
T6	-	1.8	1.8	170	0.17
R1	6.5	12.2	18.7	1,700	1.70
R2	9.7	9.0	18.7	1,840	1.84
R3	12.7	5.5	18.2	1,530	1.53
T7	-	4.6	4.6	360	0.36
T8	-	5.1	5.1	560	0.56
T9	-	2.0	2.0	200	0.20
T10	-	4.6	4.6	900	0.90
T11	-	7.4	7.4	230	0.23
R4	1.6	7.7	9.3	2,200	2.20
T12	-	10.0	10.0	690	0.69
R5	-	10.5	10.5	1,810	1.81
T13	-	11.5	11.5	470	0.47
R6	-	8.7	8.7	2,090	2.09
T14	-	4.7	4.7	560	0.56
T15	-	2.8	2.8	220	0.22
T16	-	4.2	4.2	440	0.44
M.C.	-	-	-	4,670	4.67
TOTAL	42.0	120.1	162.1	22,100	22.10

LEGEND	
	MAIN CANAL
	LATERAL CANAL & END CHECK
	MAIN ROAD
	LOCAL ROAD
	MAIN RIVER
	BRANCH RIVER
	DAM & RESERVOIR
	DIVERSION DAM
	PROJECT BOUNDARY
	CHANGWAT BOUNDARY
	AMPHOE BOUNDARY
	RAIL WAY

FEASIBILITY STUDY
ON
THE THA LAT RIVER BASIN DEVELOPMENT PROJECT

**THA LAT MAIN CANAL
GENERAL PLAN**

DRAWING NO. F - 12

JAPAN INTERNATIONAL COOPERATION AGENCY

TYPICAL CANAL SECTION

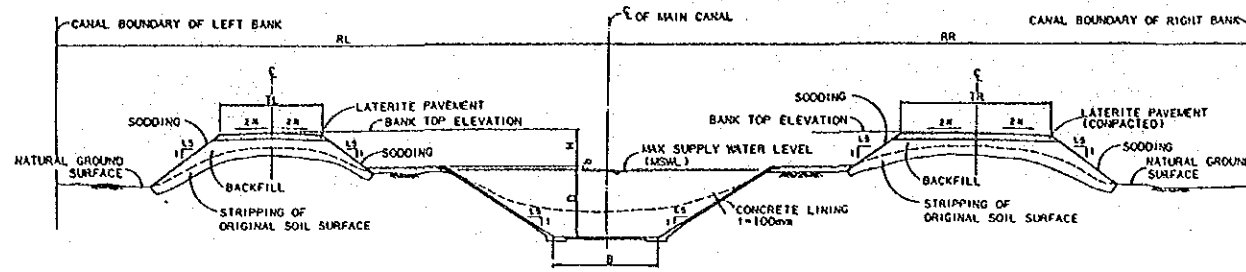

CANAL DIMENSION

STATION	Q(m³/s)	A(m²)	V(m/s)	R(m)	n	S	B(m)	D(m)	Fb(m)	H(m)	TL(m)	TR(m)	RL(m)	RR(m)	
0+000	2+740	22.10	69.62	0.317	2.671	0.015	0.000006	12.00	3.90	0.30	3.20	6.00	6.00	50.00	50.00
2+740	4+000	22.10	41.10	0.538	2.136	0.015	0.000024	7.00	3.40	0.30	2.70	6.00	6.00	50.00	50.00
4+000	5+000	22.10	41.10	0.538	2.136	0.015	0.000024	7.00	3.40	0.30	1.70	6.00	6.00	50.00	50.00
5+000	6+000	22.10	41.10	0.538	2.136	0.015	0.000024	7.00	3.40	0.30	1.70	6.00	6.00	50.00	50.00
6+000	6+700	20.91	25.80	0.810	1.730	0.015	0.000071	4.10	3.00	0.30	1.50	6.00	6.00	50.00	50.00
6+700	7+900	20.91	25.80	0.810	1.730	0.015	0.000071	4.10	3.00	0.30	1.50	6.00	6.00	30.00	30.00
7+900	9+850	20.91	25.80	0.810	1.730	0.015	0.000071	4.10	3.00	0.30	1.45	6.00	6.00	30.00	30.00
9+850	12+000	16.81	23.07	0.788	1.660	0.015	0.000071	4.10	2.85	0.30	1.40	6.00	6.00	30.00	30.00
12+000	14+700	16.97	22.01	0.771	1.591	0.015	0.000071	4.10	2.70	0.30	1.40	6.00	6.00	30.00	30.00
14+700	22+000	15.44	20.54	0.751	1.536	0.015	0.000071	4.00	2.60	0.30	1.40	6.00	6.00	30.00	30.00
22+000	22+950	15.44	20.54	0.751	1.536	0.015	0.000071	4.00	2.60	0.30	1.40	6.00	6.00	30.00	30.00
22+950	25+550	10.97	16.14	0.680	1.355	0.015	0.000071	3.80	2.25	0.30	1.25	6.00	6.00	30.00	30.00
25+550	27+570	8.47	13.20	0.642	1.221	0.015	0.000071	3.60	2.00	0.30	1.20	6.00	6.00	30.00	30.00
27+570	34+500	5.91	10.12	0.584	1.062	0.015	0.000071	3.40	1.70	0.30	1.20	6.00	6.00	30.00	30.00
34+500	34+780	5.91	10.12	0.584	1.062	0.015	0.000071	3.40	1.70	0.30	1.20	6.00	6.00	30.00	30.00
34+780	37+570	5.91	10.12	0.584	1.062	0.015	0.000071	3.40	1.70	0.30	1.20	6.00	6.00	30.00	30.00
37+570	44+000	4.67	8.48	0.550	0.962	0.015	0.000071	3.40	1.50	0.30	1.00	6.00	6.00	25.00	25.00

PROFILE OF THE LAT MAIN CANAL

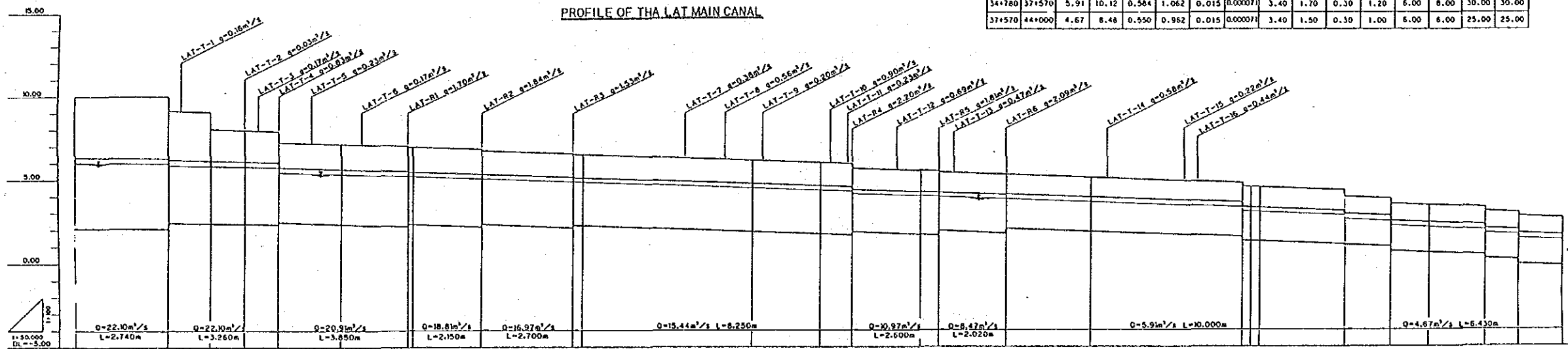

STATION	LENGTH	DISTANCE	H.C.D.	CHANNEL WIDTH	DEPTH
0+000	0.00	0.00	7.90	2.10	6.00
2+740	2.740	2.740	6.90	2.25	5.85
4+000	1.260	4.000	6.00	2.40	5.80
5+000	1.000	5.000	5.50	2.38	5.78
6+000	1.000	6.000	5.40	2.35	5.75
7+900	1.900	7.900	4.60	2.32	5.52
10+650	2.750	10.650	4.10	2.32	5.18
12+000	2.000	12.000	4.30	2.33	5.03
14+700	2.700	14.700	3.80	2.14	4.84
15+000	300	15.000	3.80	2.22	4.82
20+000	5.000	20.000	3.60	1.88	4.46
22+000	2.000	22.000	3.50	1.72	4.32
22+950	950	22.950	3.90	1.65	4.25
25+000	2.050	25.000	3.20	1.70	3.95
25+950	950	25.950	3.20	1.81	3.91
27+570	2.020	27.570	3.00	2.25	3.75
30+000	2.430	30.000	2.50	1.88	3.58
34+500	4.500	34.500	1.90	1.66	2.85
34+780	280	34.780	1.80	1.28	2.58
35+000	220	35.000	1.80	1.26	2.56
37+570	2.570	37.570	1.80	1.08	2.75
38+900	1.330	38.900	1.80	0.85	2.49
40+000	1.100	40.000	1.80	0.61	2.11
41+700	1.700	41.700	1.60	0.82	1.92
42+700	1.000	42.700	1.40	0.58	1.82
44+000	1.300	44.000	1.30	0.17	1.33

FEASIBILITY STUDY
ON
THE THA LAT RIVER BASIN DEVELOPMENT PROJECT

THA LAT MAIN CANAL
PROFILE AND TYPICAL SECTION

DRAWING NO. F - 13

JAPAN INTERNATIONAL COOPERATION AGENCY

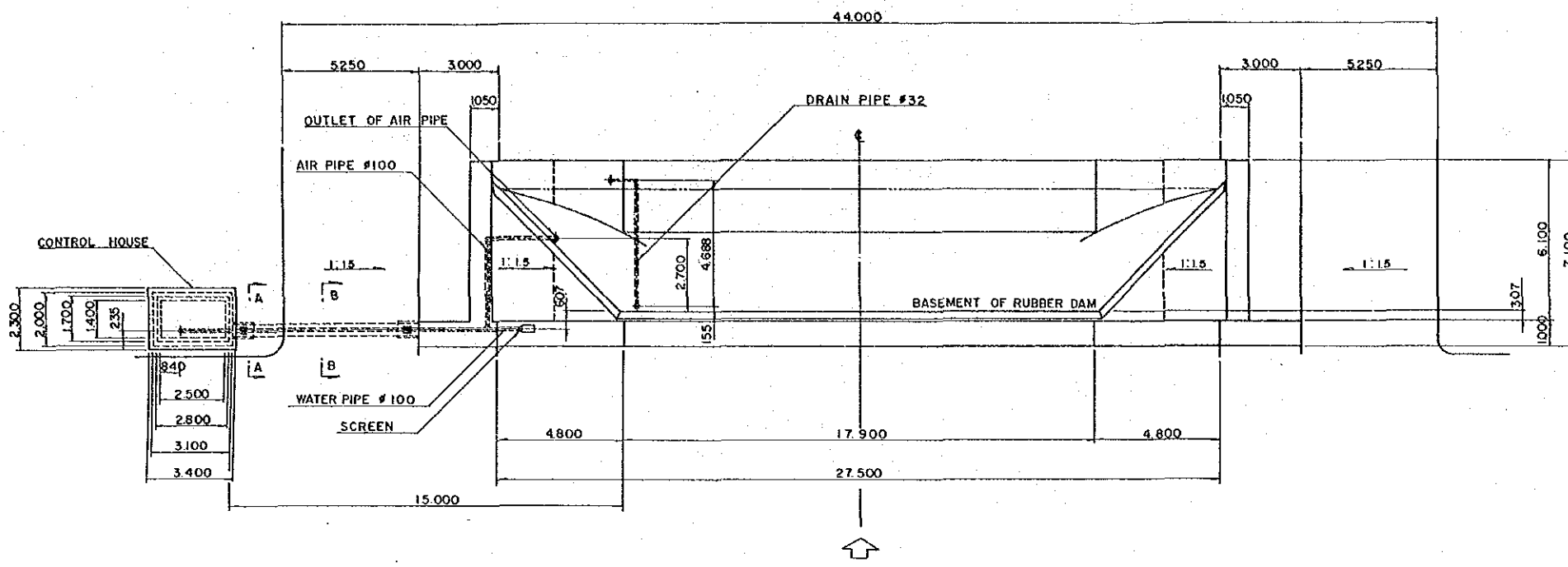

P L A N

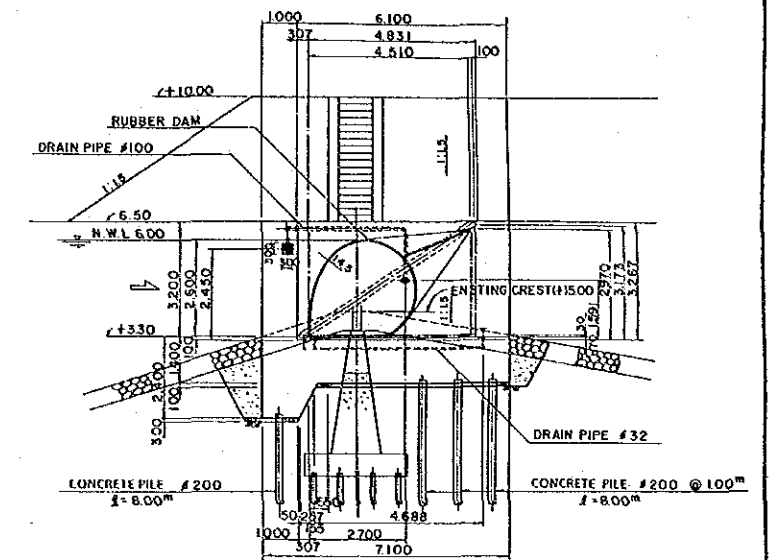

SECTION

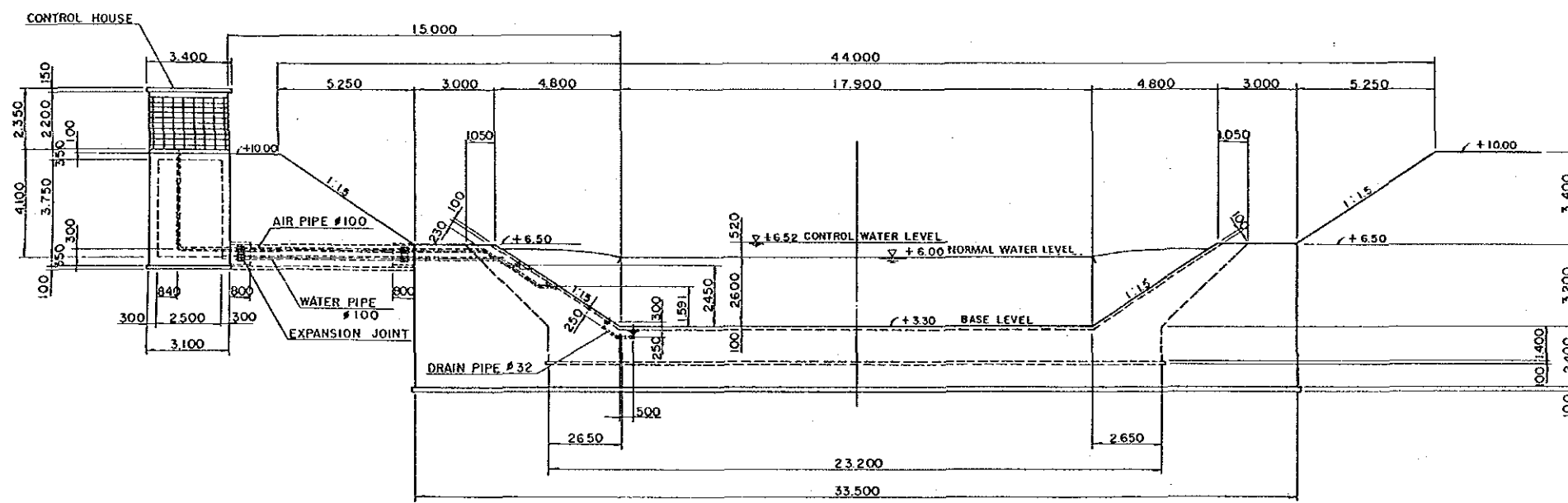

ELEVATION

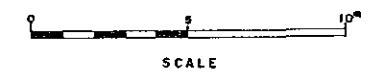

FEASIBILITY STUDY
ON
THE THA LAT RIVER BASIN DEVELOPMENT PROJECT

THA LAT MAIN CANAL
DIVERSION WEIR

DRAWING NO. F - 14

JAPAN INTERNATIONAL COOPERATION AGENCY

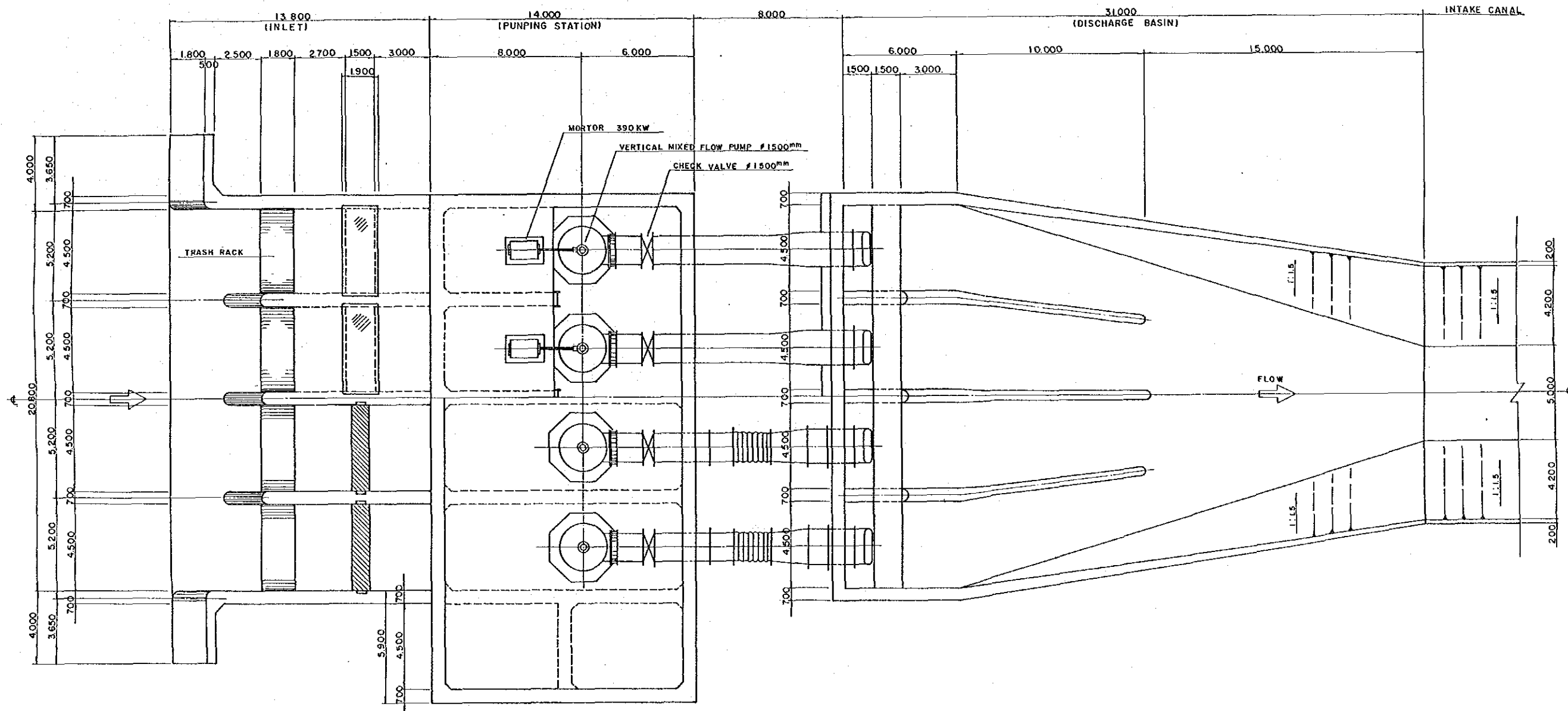

PLAN OF BANG RAKONG PUMPING STATION

FEASIBILITY STUDY ON THE THA LAT RIVER BASIN DEVELOPMENT PROJECT
BANG PAKONG MAIN CANAL PLAN OF PUMPING STATION
DRAWING NO. F - 15
JAPAN INTERNATIONAL COOPERATION AGENCY

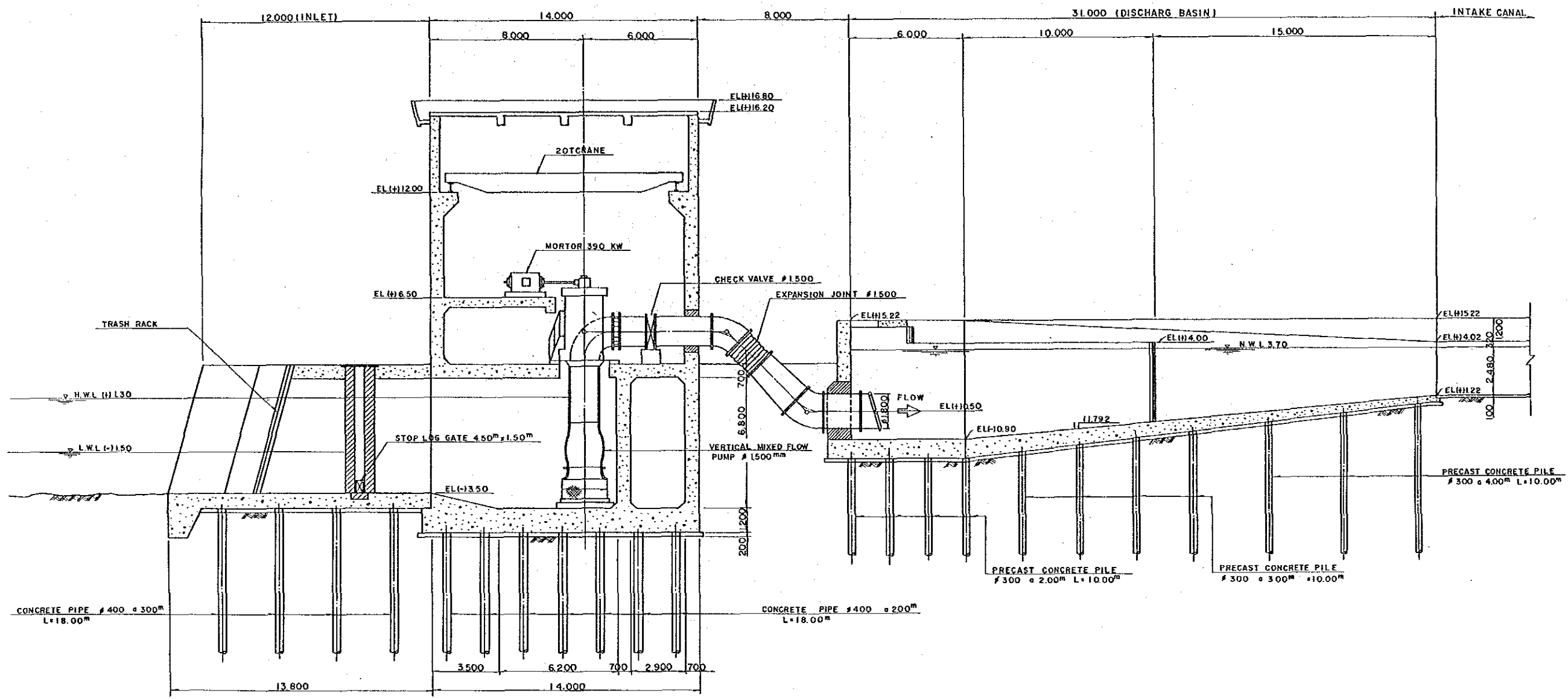

PROFILE OF BANG PAKONG PUMPING STATION

FEASIBILITY STUDY
ON
THE THA LAT RIVER BASIN DEVELOPMENT PROJECT

**BANG PAKONG MAIN CANAL
SECTION OF PUMPING STATION**

DRAWING NO. F - 16

JAPAN INTERNATIONAL COOPERATION AGENCY

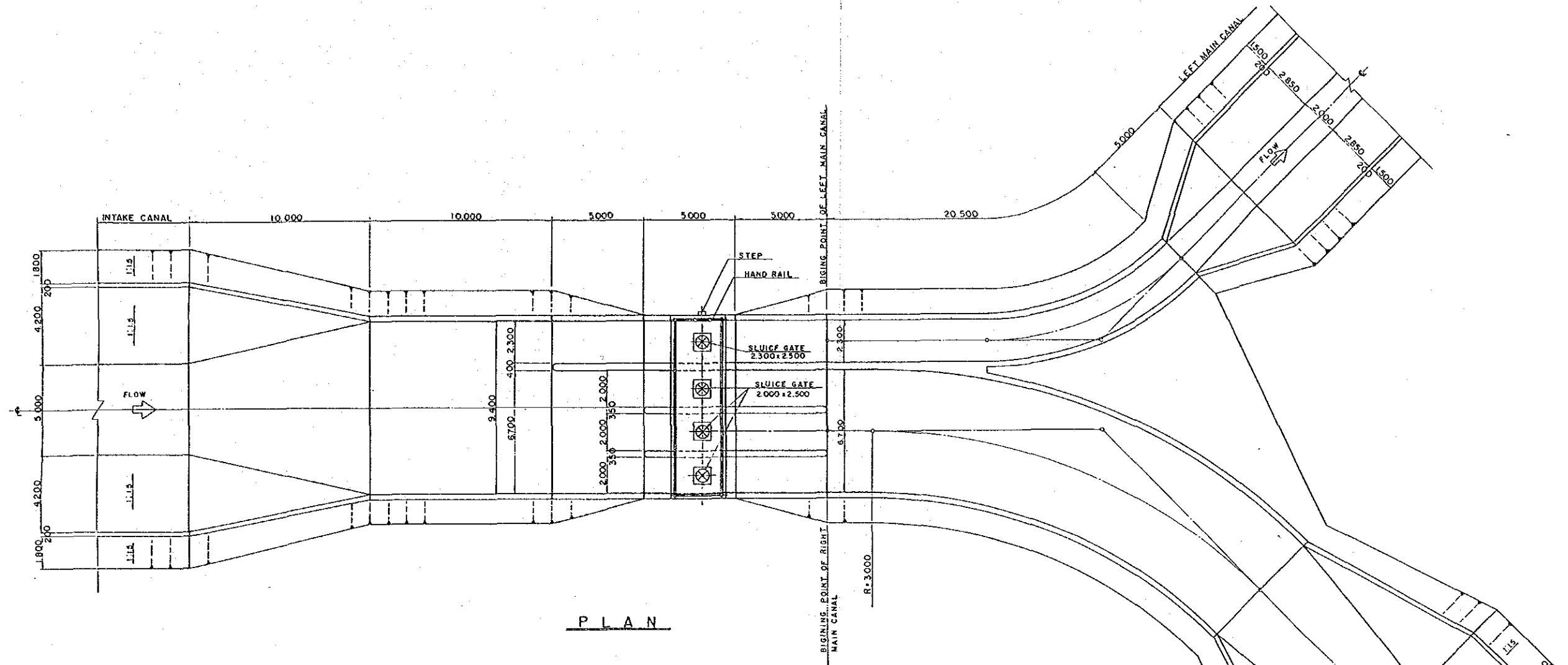

PLAN

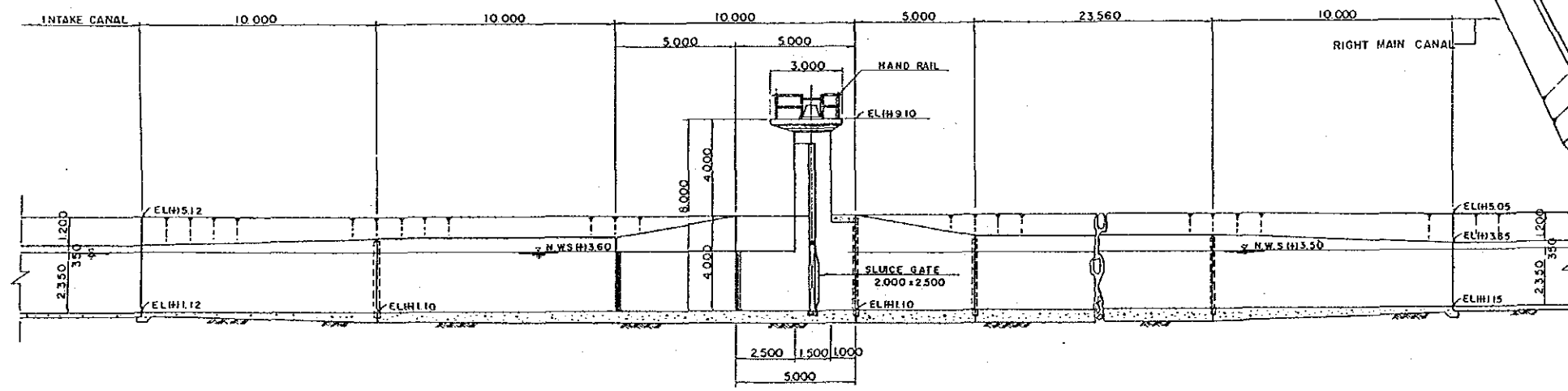

PROFILE OF DIVERSION WORK

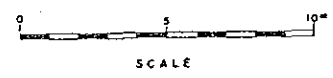

FEASIBILITY STUDY
ON
THE THA LAT RIVER BASIN DEVELOPMENT PROJECT

**BANG PAKONG MAIN CANAL
DIVERSION WORK**

DRAWING NO. F - 17

JAPAN INTERNATIONAL COOPERATION AGENCY

TYPICAL CANAL SECTION

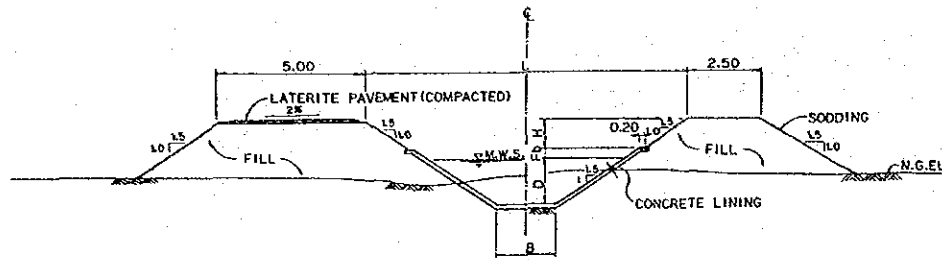

CANAL DIMENSION

STATION	Q(m ³ /s)	A(m ²)	V(m/s)	R(m)	l	n	B(m)	D(m)	Fp(m)	H(m)	L(m)	REMARKS
INTAKE CANAL												
0+000	0+700	17.84	21.626	0.815	1.551	1/12.000	0.015	5.00	2.48	0.32	1.20	17.40
LEFT MAIN CANAL												
0+000	1+600	4.75	6.905	0.693	0.697	1/8.000	0.015	2.00	1.58	0.32	1.00	11.10
1+600	5+700	3.50	5.460	0.641	0.797	1/8.000	0.015	1.80	1.40	0.30	1.00	10.30
5+700	9+600	2.11	3.741	0.566	0.662	1/8.000	0.015	1.40	1.18	0.22	0.90	8.70
9+600	12+000	0.64	1.529	0.419	0.421	1/8.000	0.015	1.00	0.73	0.27	0.60	6.20

PROFILE OF INTAKE AND LEFT MAIN CANAL

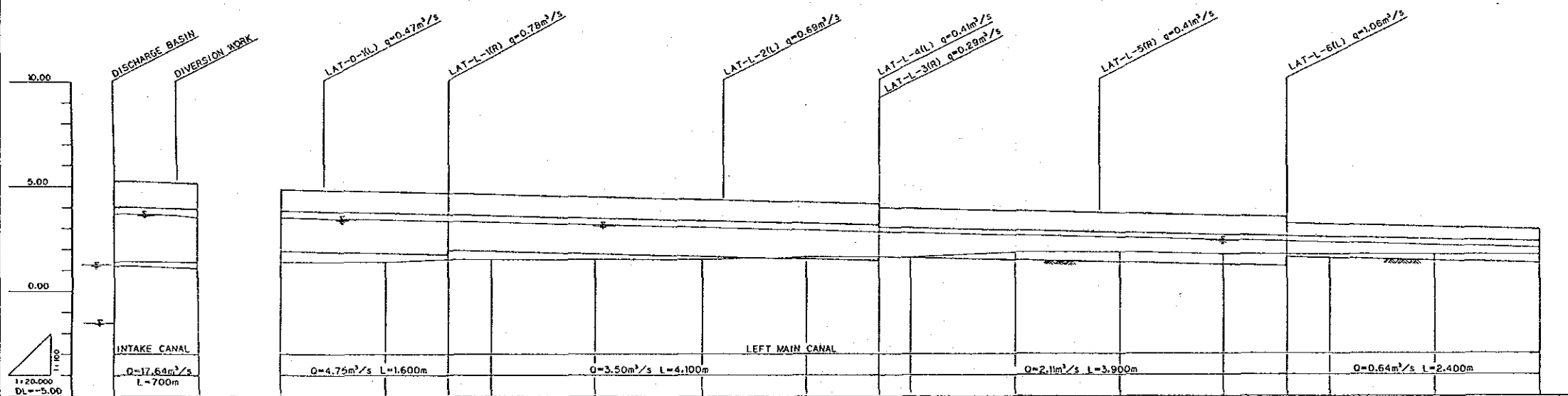

STATION	LENGTH	DISTANCE	N.G.E.L.	C.B.E.L.	W.S.E.L.	SLOPE
0+000	0.00	0.00	1.40	1.22	3.70	1:48.000
0+700	700	700	1.40	1.02	3.50	
0+000	0.00	0.00	1.40	1.92	3.50	1:8.000
1+000	1,000	1,000	1.40	1.79	3.37	
1+600	600	1,600	1.50	1.89	3.29	
2+000	400	2,000	1.50	1.85	3.25	
3+000	1,000	3,000	1.50	1.72	3.12	
4+000	1,000	4,000	1.50	1.62	3.00	
5+000	1,000	5,000	1.60	1.47	2.87	
5+700	700	5,700	1.60	1.50	2.76	
6+000	300	6,000	1.60	1.37	2.75	
7+000	1,000	7,000	1.80	1.44	2.62	
8+000	1,000	8,000	1.80	1.32	2.50	
9+000	1,000	9,000	1.70	1.19	2.37	
9+600	600	9,600	1.70	1.11	2.29	
10+000	400	10,000	1.70	1.52	2.25	
11+000	1,000	11,000	1.70	1.39	2.12	
12+000	1,000	12,000	1.70	1.27	2.00	

FEASIBILITY STUDY
ON
THE THA LAT RIVER BASIN DEVELOPMENT PROJECT

**BANG PAKONG MAIN CANAL
PROFILE AND TYPICAL SECTION
INTAKE CANAL & LEFT MAIN CANAL**

DRAWING NO. F - 18

JAPAN INTERNATIONAL COOPERATION AGENCY

TYPICAL CANAL SECTION

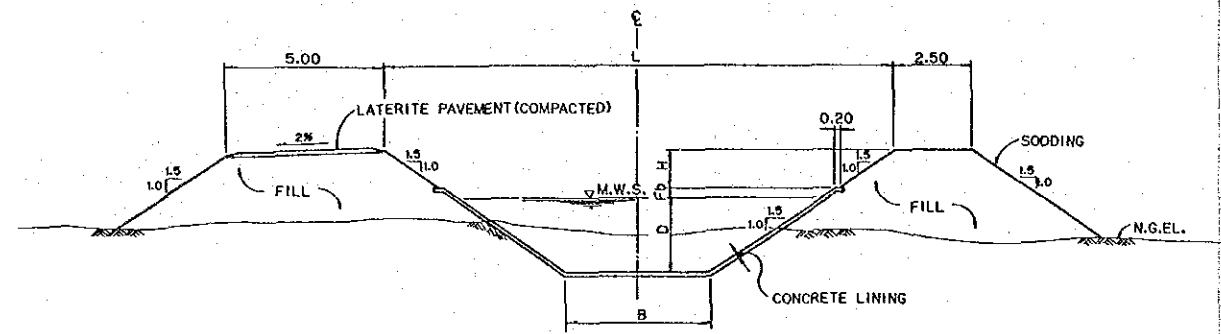

CANAL DIMENSION

STATION	Q(m ³ /s)	A(m ²)	V(m/s)	R(m)	I	n	B(m)	D(m)	Fb(m)	H(m)	L(m)	REMARKS
0+000	3+300	12.89	19.094	0.679	1.461	1/16,000	0.015	4.60	2.35	0.35	1.20	16.70
3+300	7+600	10.74	16.608	0.649	1.365	1/16,000	0.015	4.20	2.21	0.29	1.20	15.70
7+600	14+900	9.23	14.798	0.626	1.293	1/16,000	0.015	3.80	2.12	0.28	1.20	15.00
14+900	19+000	5.36	9.818	0.548	1.061	1/16,000	0.015	2.80	1.79	0.31	1.20	12.50
19+000	24+000	3.00	6.375	0.477	0.861	1/16,000	0.015	2.00	1.50	0.20	1.00	10.50

PROFILE OF RIGHT MAIN CANAL

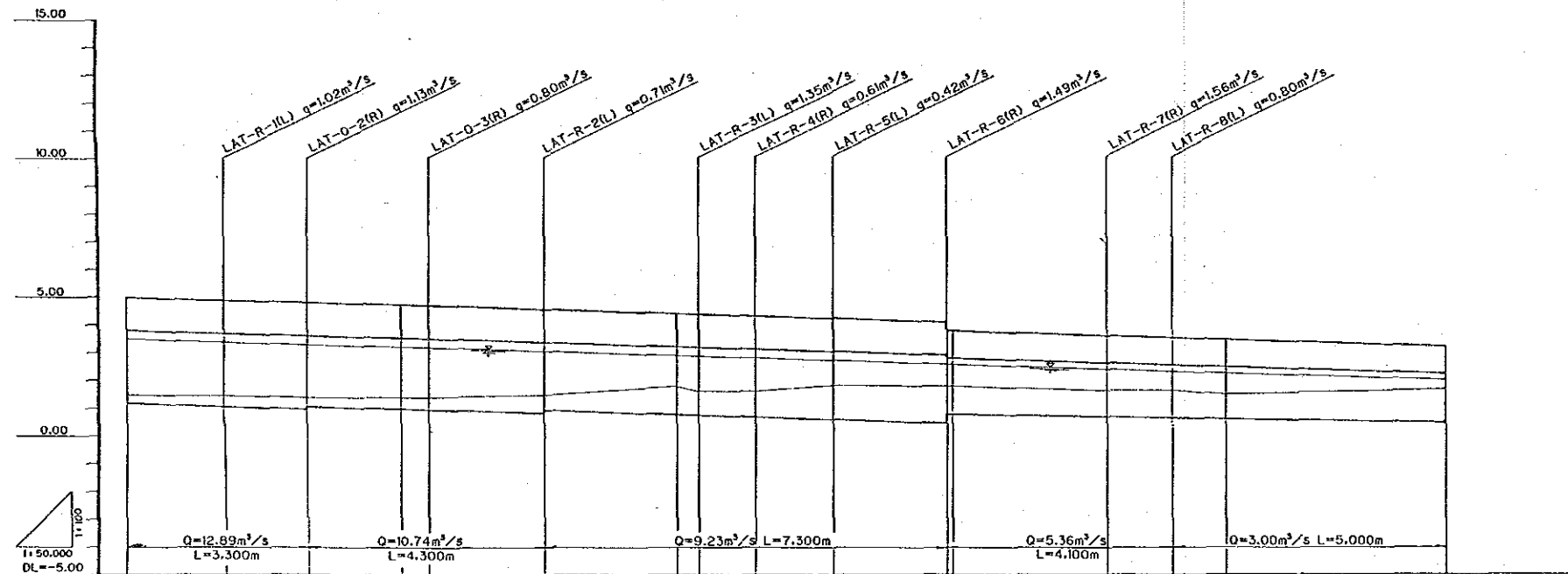

STATION	LENGTH	DISTANCE	N.G.E.L.	SLOPE	
				PLAN	SECTION
0+000	0.00	0.00	1.50	1:15	3:50
1+600	1.600	1.600	1.50	1:04	3:39
3+300	1.500	3.300	1.48	0.98	3:29
5+000	1.700	5.000	1.40	0.98	3:19
5+500	500	5.500	1.40	0.95	3:16
7+600	2.100	7.600	1.50	0.80	3:02
10+000	2.400	10.000	1.80	0.75	2:67
10+400	400	10.400	1.60	0.73	2:55
11+400	1.000	11.400	1.60	0.67	2:79
12+600	1.400	12.800	1.80	0.58	2:70
14+900	2.100	14.900	1.80	0.45	2:57
15+000	100	15.000	1.80	0.77	2:56
17+600	2.600	17.600	1.60	0.60	2:39
19+000	1.200	19.000	1.60	0.52	2:31
20+000	1.000	20.000	1.50	0.75	2:25
24+000	4.000	24.000	1.70	0.50	2:00

FEASIBILITY STUDY
ON
THE THA LAT RIVER BASIN DEVELOPMENT PROJECT

**BANG PAKONG MAIN CANAL
PROFILE AND TYPICAL SECTION
RIGHT MAIN CANAL**

DRAWING NO. F-19

JAPAN INTERNATIONAL COOPERATION AGENCY

THA LAT RIVER BASIN DEVELOPMENT PROJECT THA LAT EXPANSION AREA

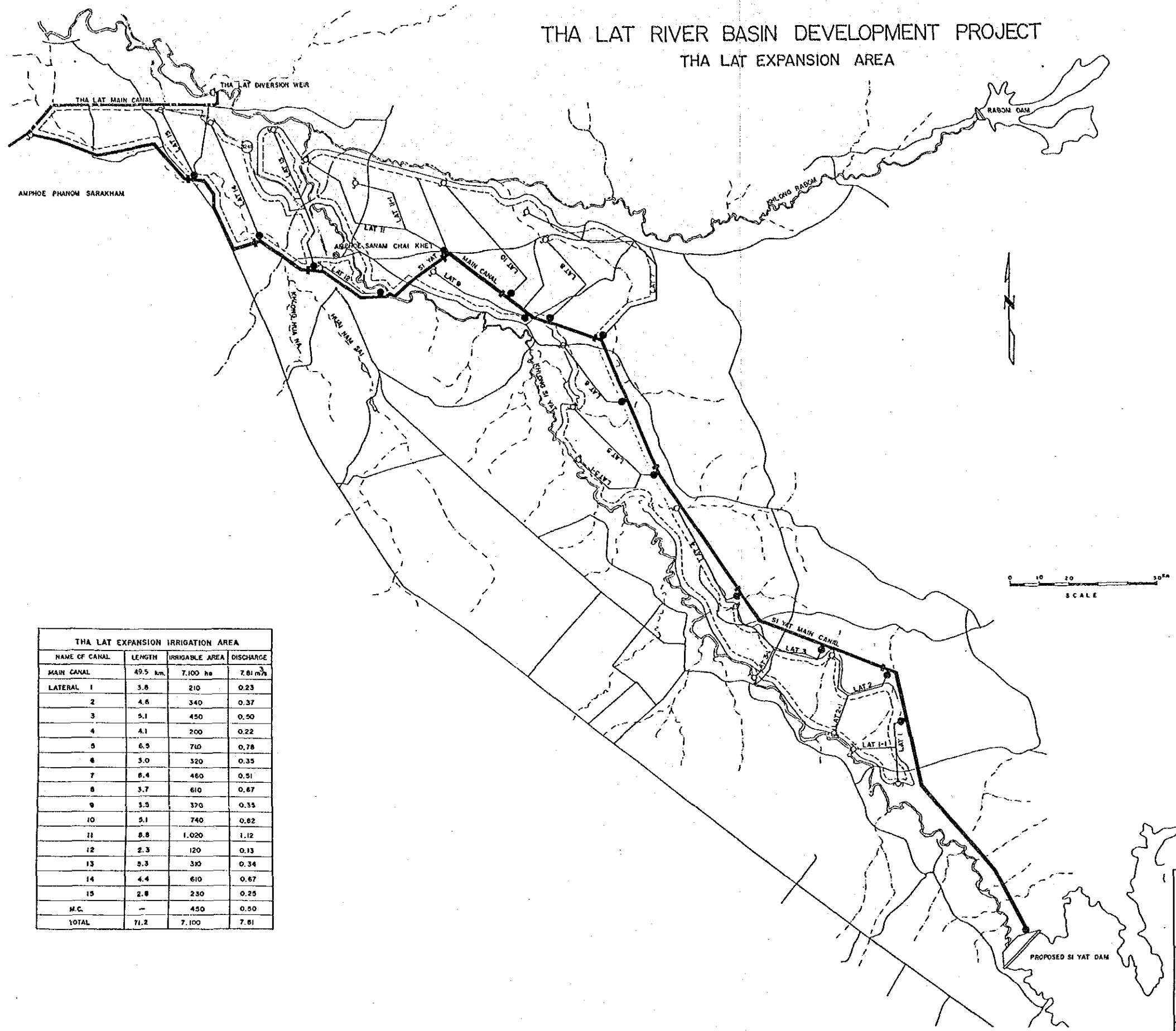

THA LAT EXPANSION IRRIGATION AREA			
NAME OF CANAL	LENGTH	IRRIGABLE AREA	DISCHARGE
MAIN CANAL	49.5 km.	7,100 ha	7.81 m ³ /s
LATERAL 1	5.8	210	0.23
2	4.6	340	0.37
3	5.1	450	0.50
4	4.1	200	0.22
5	6.5	710	0.78
6	3.0	320	0.35
7	6.4	460	0.51
8	3.7	610	0.67
9	3.3	370	0.35
10	5.1	740	0.82
11	8.8	1,020	1.12
12	2.3	120	0.13
13	5.3	380	0.34
14	4.4	610	0.67
15	2.8	230	0.25
M.C.	-	450	0.50
TOTAL	71.2	7,100	7.81

LEGEND	
	MAIN CANAL TO BE REHABILITATED
	MAIN CANAL TO BE CONSTRUCTED
	LATERAL CANAL
	HEAD GATE
	END CHECK
	CHECK NEWLY CONSTRUCTED
	EXISTING CHECK

LEGEND	
	MAIN CANAL
	LATERAL CANAL & END CHECK
	MAIN ROAD
	LOCAL ROAD
	MAIN RIVER
	BRANCH RIVER
	DAM & RESERVOIR
	DIVERSION DAM
	PROJECT BOUNDARY
	CHANGWAT BOUNDARY
	AMPHOE BOUNDARY
	RAIL WAY

FEASIBILITY STUDY
ON
THE THA LAT RIVER BASIN DEVELOPMENT PROJECT

**SI YAT MAIN CANAL
GENERAL PLAN**

DRAWING NO. F - 20

JAPAN INTERNATIONAL COOPERATION AGENCY

TYPICAL CANAL SECTION

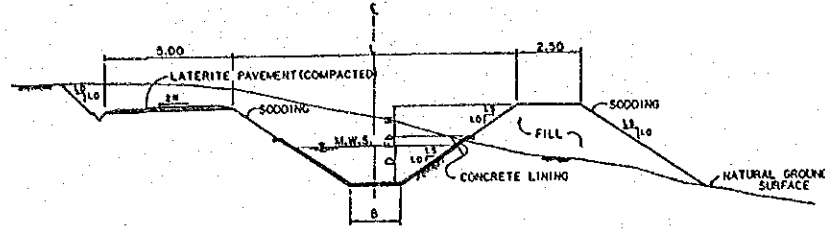

CANAL DIMENSION

STATION	0(m ³ /s)	A(m ²)	V(m/s)	R(m)	i	n	β(m)	D(m)	Fβ(m)	H(m)	L(m)	REMARKS
0+000	18+100	7.81	5.990	1.319	0.833	0.00050	0.015	2.00	1.44	0.36	1.20	11.40
16+100	26+000	6.49	5.184	1.258	0.775	0.00050	0.015	1.80	1.35	0.35	1.20	10.90
28+000	29+500	4.85	4.185	1.173	0.698	0.00050	0.015	1.60	1.22	0.38	1.00	9.80
29+500	31+900	3.01	3.778	0.800	0.661	0.00025	0.015	1.60	1.14	0.26	1.00	9.20
31+900	39+300	1.89	2.695	0.714	0.557	0.00025	0.015	1.20	0.99	0.21	0.90	7.90
39+300	49+500	0.75	1.343	0.587	0.393	0.00025	0.015	1.00	0.67	0.23	0.60	5.90

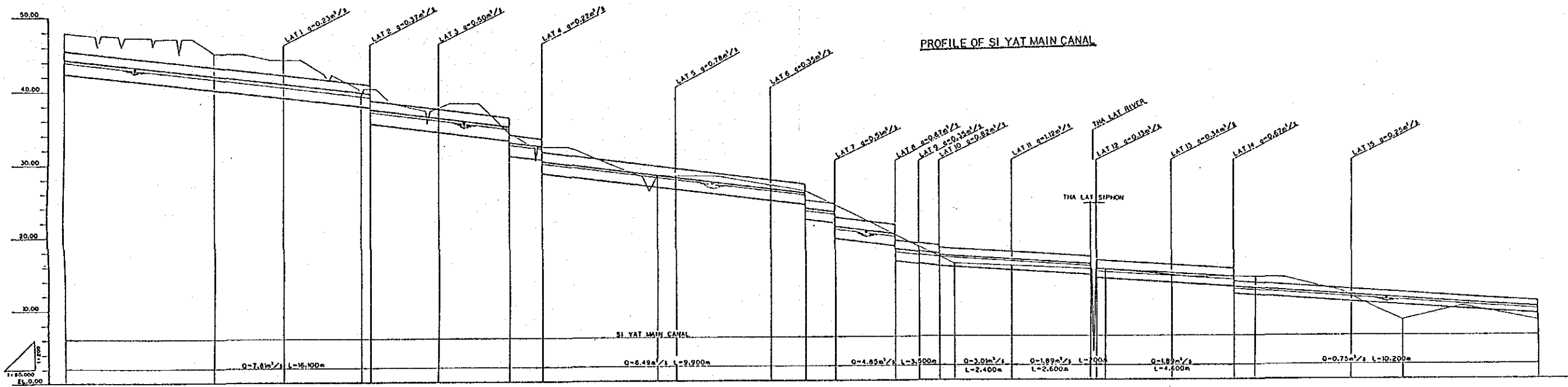

STATION	LENGTH	DISTANCE	N.G.S.L.	C.B.E.L.	W.S.E.L.	SLOPE
0+000	0.00	0.00	48.00	42.56	44.00	
5+000	5.000	5.000	45.00	40.06	41.50	
7+400	2.400	7.400	44.00	38.06	40.30	
12+600	5.200	12.600	37.20	34.26	35.70	
15+000	2.400	15.000	33.50	31.06	34.50	
16+100	1.100	16.100	32.00	28.51	31.50	
20+000	3.900	20.000	28.00	26.56	27.91	
23+600	3.600	23.600	26.80	24.66	26.01	
25+000	1.400	25.000	26.00	23.96	25.31	
26+000	1.000	26.000	24.00	21.96	23.31	
28+000	2.000	28.000	20.00	18.36	17.56	
28+800	800	28.800	19.40	17.19	17.19	
29+000	200	29.000	17.00	15.69	16.29	
30+000	500	30.000	16.00	15.56	16.70	
31+900	1.900	31.900	15.60	15.20	16.20	
34+000	2.000	34.000	13.00	14.58	15.57	
35+000	1.000	35.000	12.00	13.90	14.89	
37+800	2.800	37.800	14.00	13.30	14.34	
39+300	1.500	39.300	14.00	12.02	13.81	
40+000	700	40.000	14.00	10.96	11.63	
43+000	3.000	43.000	11.00	10.12	10.80	
49+500	6.500	49.500	8.00	9.70	10.37	
49+500	4.500	49.500	8.00	8.00	9.24	

FEASIBILITY STUDY
ON
THE THA LAT RIVER BASIN DEVELOPMENT PROJECT

SI YAT MAIN CANAL
PROFILE AND TYPICAL SECTION

DRAWING NO. F-21

JAPAN INTERNATIONAL COOPERATION AGENCY

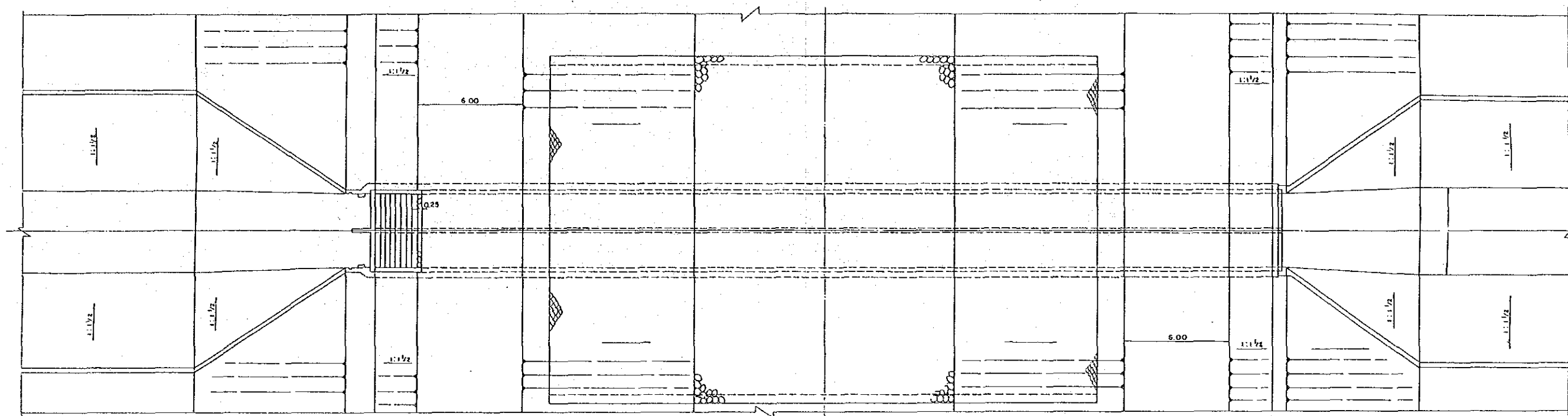

P L A N

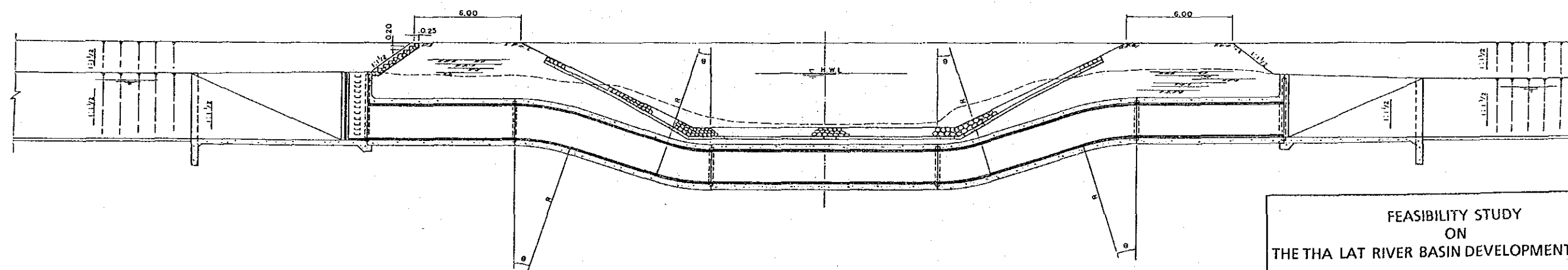

P R O F I L E

FEASIBILITY STUDY
ON
THE THA LAT RIVER BASIN DEVELOPMENT PROJECT

CANAL RELATED STRUCTURE (1)
TYPICAL SIPHON

DRAWING NO. F-22

JAPAN INTERNATIONAL COOPERATION AGENCY

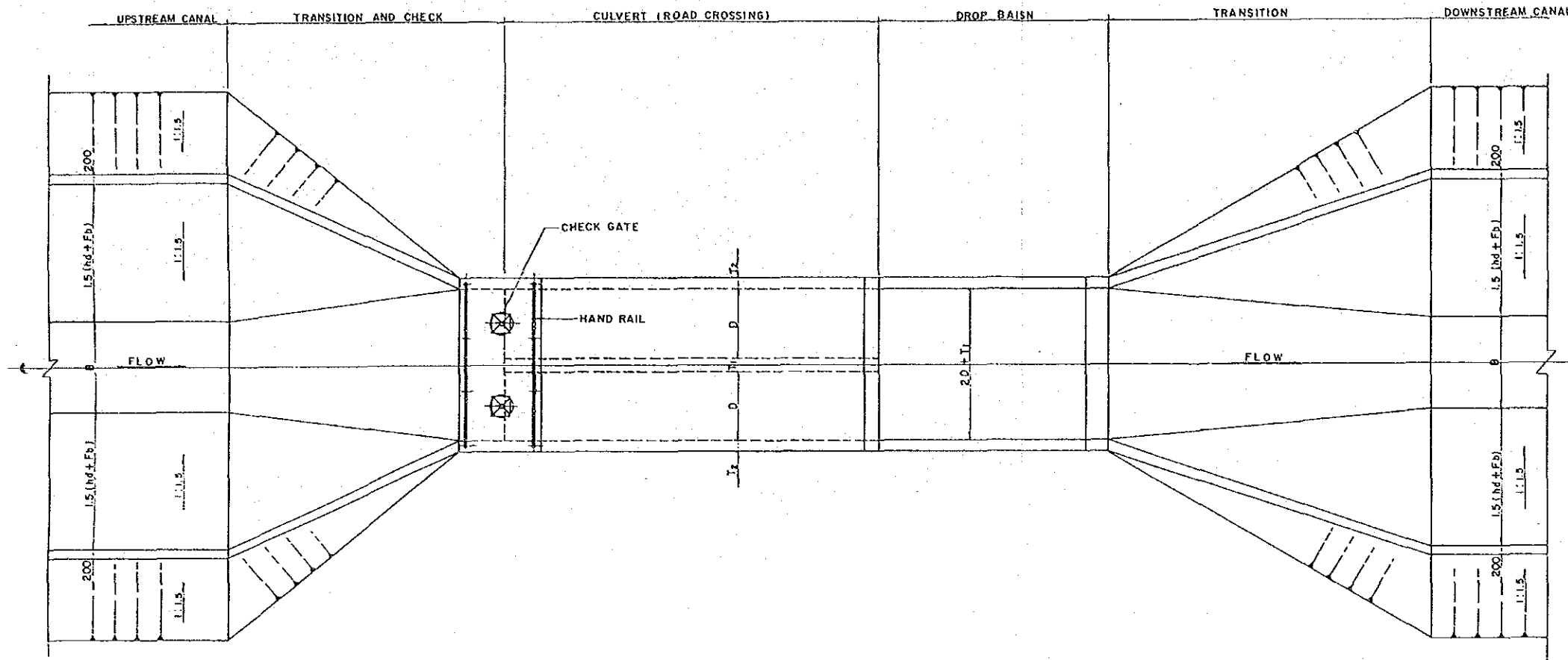

P L A N

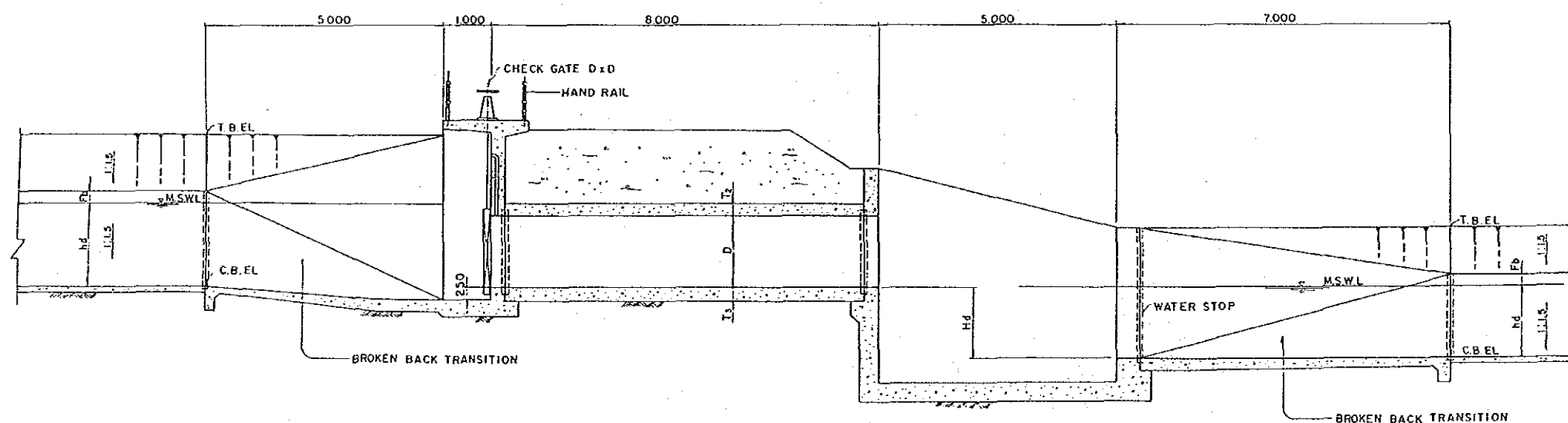

P R O F I L E

FEASIBILITY STUDY ON THE THA LAT RIVER BASIN DEVELOPMENT PROJECT
CANAL RELATED STRUCTURE (2) TYPICAL ROAD CROSSING AND DROP
DRAWING NO. F-23
JAPAN INTERNATIONAL COOPERATION AGENCY

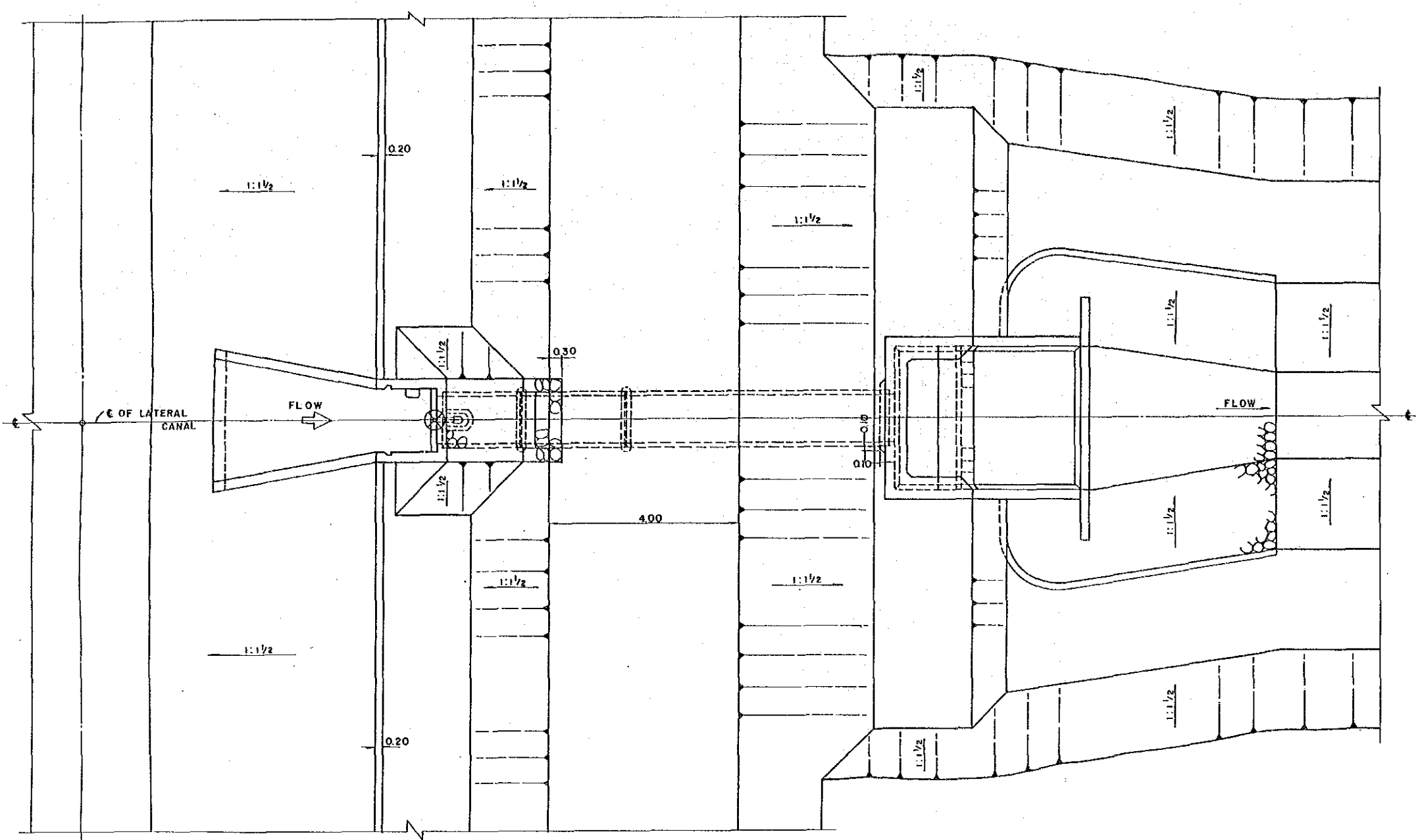

P L A N

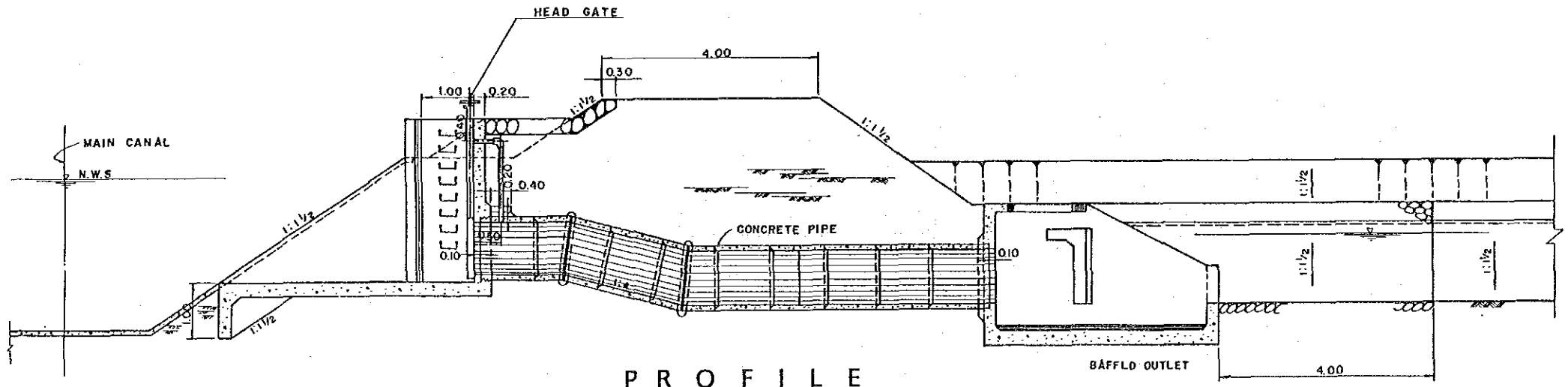

P R O F I L E



<p>FEASIBILITY STUDY ON THE THA LAT RIVER BASIN DEVELOPMENT PROJECT</p>
<p>CANAL RELATED STRUCTURE (3) TYPICAL HEAD GATE</p>
<p>DRAWING NO. F-24</p>
<p>JAPAN INTERNATIONAL COOPERATION AGENCY</p>

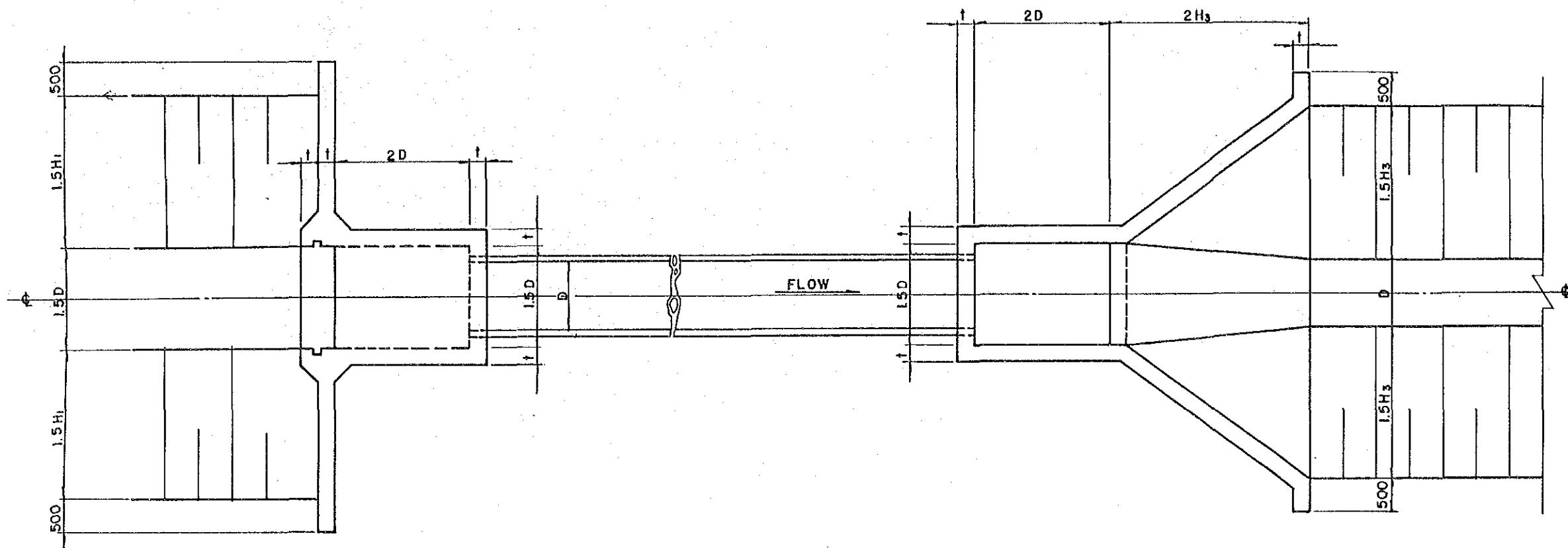

P L A N

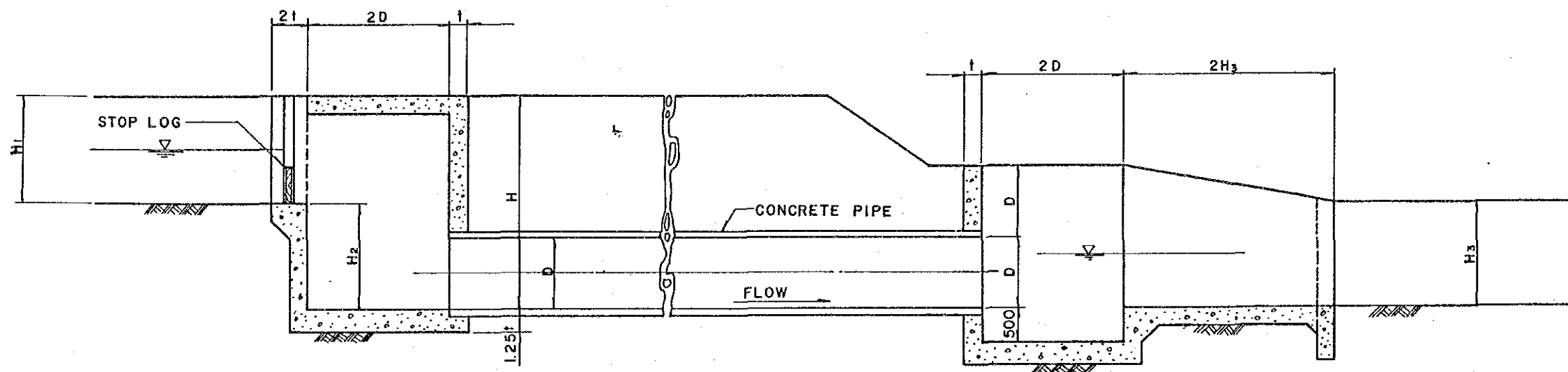

P R O F I L E

FEASIBILITY STUDY ON THE THA LAT RIVER BASIN DEVELOPMENT PROJECT
CANAL RELATED STRUCTURE (4) END CHECK
DRAWING NO. F - 25
JAPAN INTERNATIONAL COOPERATION AGENCY

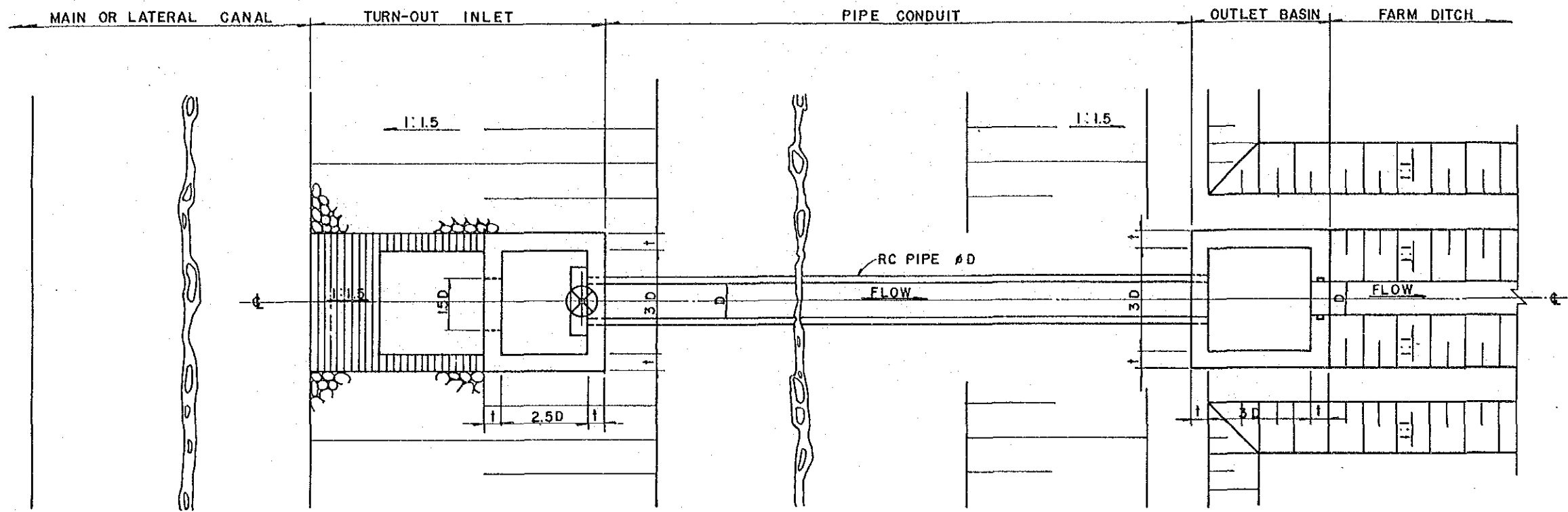

P L A N

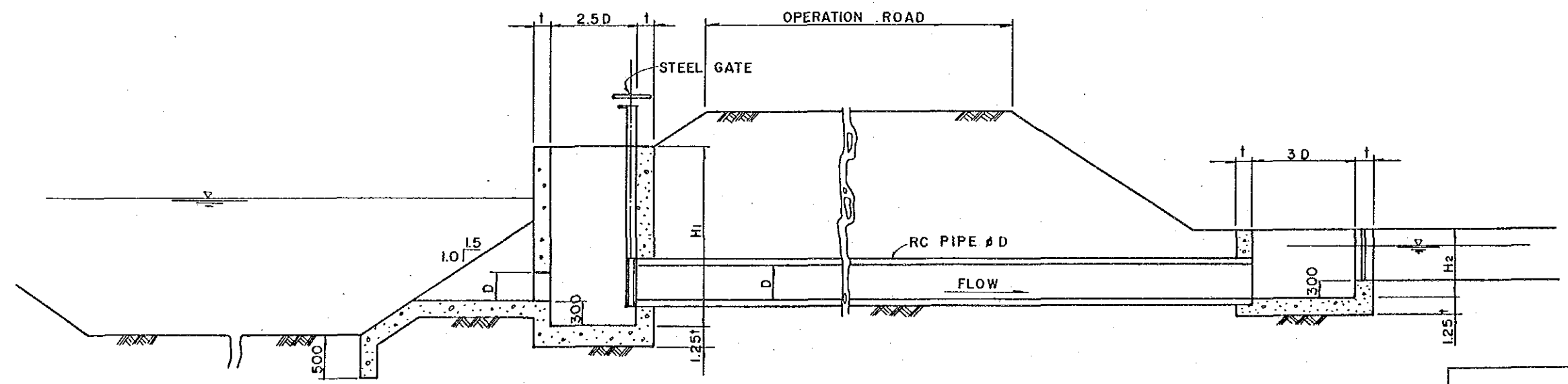

P R O F I L E

FEASIBILITY STUDY ON THE THA LAT RIVER BASIN DEVELOPMENT PROJECT
CANAL RELATED STRUCTURE (5) TYPICAL TURN-OUT
DRAWING NO. F-26
JAPAN INTERNATIONAL COOPERATION AGENCY

JICA