

資 料

1. 計画打合せチーム対処方針等
2. K I M C 組織図
3. N C P D 組織図
4. 機材据付専門家報告
5. スタジオ位置図等
6. 主な A V 機器構成
7. U N F P A 人口教育プログラムテキスト
8. I E C 車図面等
9. Population Policy Guidelines

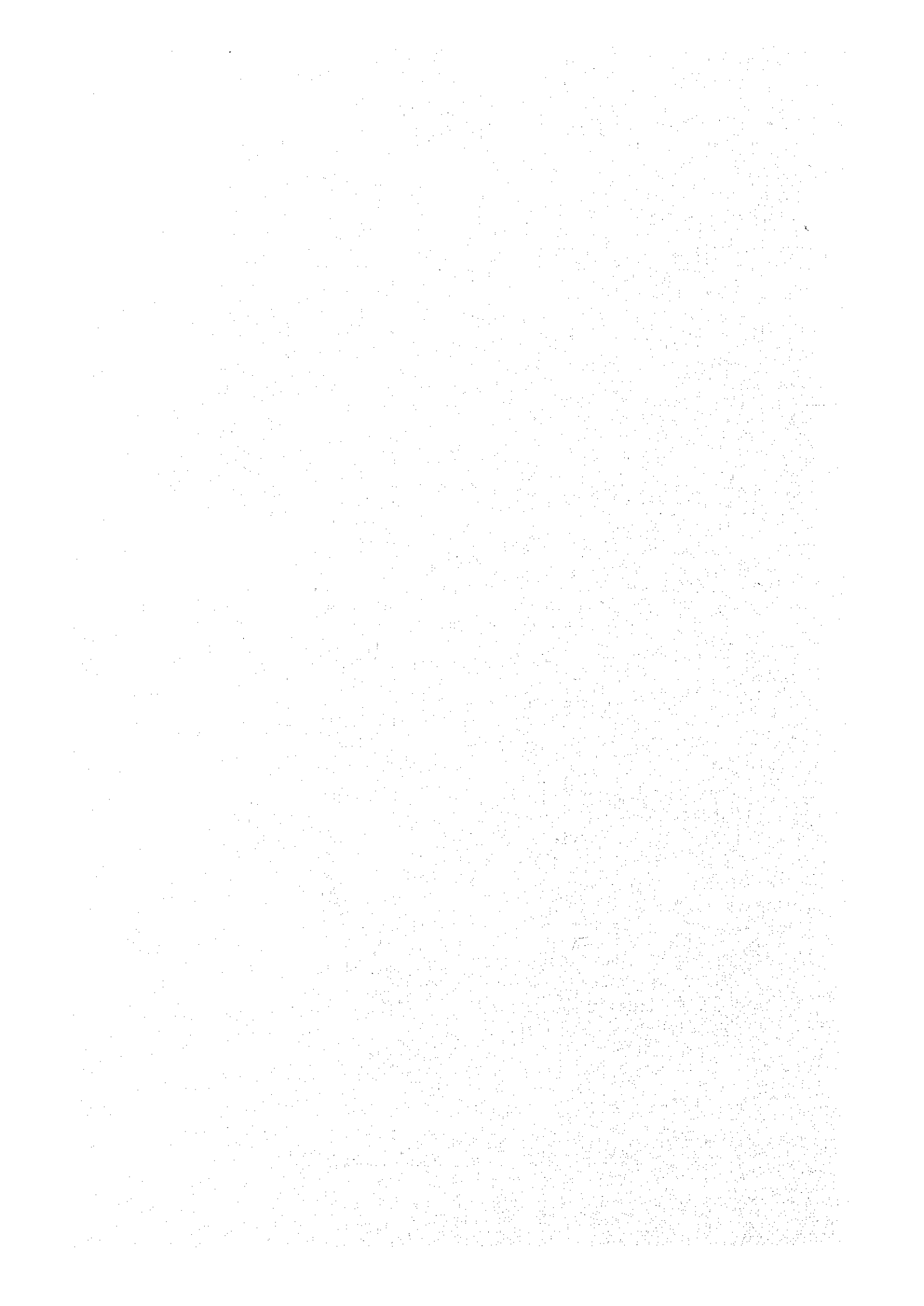

1. 計画打合せチーム対処方針等

(1) 検討事項

1) 専門家の派遣

リーダーが派遣されていない。

2) 供与機材の設置場所（スタジオ等の建設）

昭和63年度機材（AV機器）が、本年12月にナイロビに搬送される予定であるが、当機材設置予定場所であるKIMCにおけるスタジオ等建設が現在のところ完了していない。（平成2年度に現地運営体制整備費として、約5,000千円を予算措置する予定である。）

3) 専門家用オフィスの確保（新規分）

現在KIMCにて建設中のスタジオ等施設に、当プロジェクト専門家オフィスが設置される予定であるが、具体的に建設中の施設内での位置及びスペース等につき確認する必要がある。

4) NCPDのコーディネーティング機能

NCPDは調整官庁であり、メディアの制作手段・人材等を有していないため、当プロジェクトはケニア放送局のトレーニングセンターであるKIMCの協力を得て、プロジェクトを実施することとしている。しかしNCPDは副大統領府、KIMCは情報省と所管監督庁が異なっており、命令系統の違いによる問題が発生することも予想される。このため、NCPDの十分なコーディネーティング機能が果たされているか確認する必要がある。なお、NCPDのKIMCに対するコーディネーティングについて何らかの問題があれば、当方より要望なりとも伝えることも検討する。

5) NCPDの機能強化等

KIMCに対する技術移転は、主にビデオ等作品の制作が目的となるが、NCPDについては、組織の機能強化を具体的にどのようにして行なうか漠然としている。（具体的には専門家・研修員及び機材供与を通じて機能強化に資することとするが、プロジェクトフィールドでの活動を、NCPDの活性化の手段としていくことを検討する。）

6) ローカルコスト負担

今後、NCPD及びKIMCにてビデオ作品等が制作されることとなるが、その際制作費等を負担できないことが十分予想される。（今回、実施計画を立案する中で、必要経費等を積算し、その対応につき日本側で検討する。）

7) 機材の管理責任体制

主要機材（ビデオ関連）は、KIMCに設置されるが、当方の協力機関はNCPDで

あり、機材にかかるケニア側の責任体制を確認する必要がある。（なお、ケニア側に供与した機材については、原則的に日本側に管理責任はないものの、問題が生じる恐れがあると判断された場合、ケニア側に対し機材の管理等につき文書化を依頼することも検討する。）

8) 主幹メディア

ビデオテープ（ビデオ映像）を中心に作品の制作を行なうが、ビデオ・テレビの保有台数の少ない当国において、ビデオテープによる I E C 活動についてその効果なりが十分理解されていないと思われ、充分説明する必要がある。

(2) 対処方針

1) 協議結果議事録（ミニッツ）の作成

ケニア側との協議内容をミニッツとして取りまとめ、専門家チーム団長と相手国の責任者と署名のうえ確認する。

2) I E C 基本方略の策定

当プロジェクトの実施計画を立案するに当たり、① I E C 活動の対象の確定、②メディアの選定と組み合わせ、③普及方法等につき基本方略を策定する。

3) プロジェクトフィールド（(1)の I E C 基本方略の具体化）

I E C 基本方略に基づき試作した作品のテスト、普及等の実験場所として2ヶ所（カカメガ、メル）のフィールドを予定しており、同地域を正式に確定するとともに、同地域での活動内容等を確定する。

4) プロジェクトフィールドでの活動（作品のモニタリング・エバリュエーション）

制作した主にビデオテープ作品の効果測定等を巡回広報車及びビデオ・テレビを設置したコミュニティーセンター等で行ない、ビデオテープ以外のポスター等（マルチメディア）の組み合わせも含め効果的のモデルを作る。

5) 今後の機材供与

基本方略等に基づき、平成2年度の機材内容について協議する。なお、予算額は日本の予算制度により現時点では決定されていないことから、必要機材をリストアップしプライオリティーづけをしておき、速やかな機材調達ができるよう準備しておく。

6) 専門家派遣

専門家の分野（MCH/F P、人口学、マスメディア等）等、及び業務内容につき具体的に検討する。

7) 研修員受入れ

研修内容等を検討する。特に政策策定及び調整官庁である N C P D の人材育成はビデオ映像等の研修が中心の K I M C とは異なり、機関の性格から研修内容が総花的となり

やすく、効果的な研修内容等につき検討する。

8) ビデオテープ作品の内容

作品の内容を決める際に、ケニア側の企画段階等でのFP/MCH分野のしかるべき人材の配置につき協議する。また企画段階等での日本側にどのような支援が出来るのか、又は必要なのかを検討する。

9) 普及（主にビデオテープ作品）

制作されたビデオテープは、試作段階をへて普及されることになるが、6.(3)で述べているように、普及については試作品をテストングする中で普及方法を検討していくこととし、あくまでも主力は作品の制作に置く。

10) 成果品の管理等

主にビデオテープ作品について、成果品（マスターテープ）の保管・保存についてルール化を図る。また、今後のIEC分野の活動に資するため成果品にかかるシナリオ等の記録保存について検討する。

11) AV機器オペレーション

人材育成（対象者等）に係る計画を策定する。

2. KIMC 組織図

KENYA INSTITUTE OF MASS COMMUNICATION

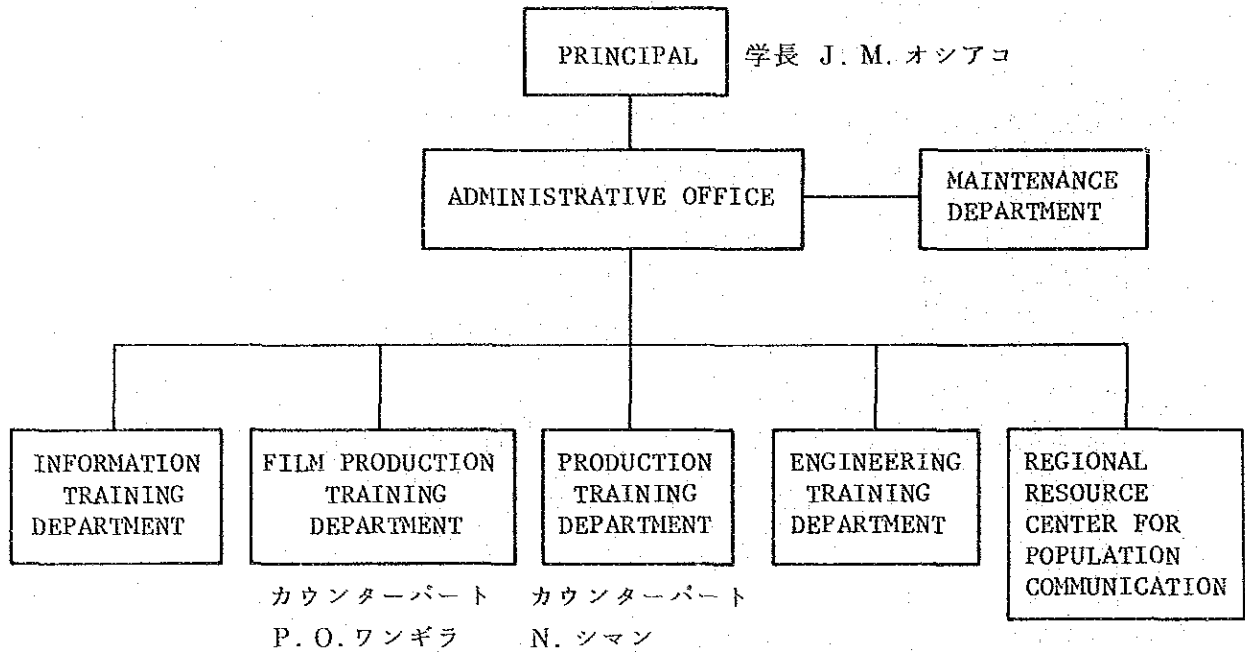

主な制作等スタッフの構成

- | | | |
|-----------------|------|-----|
| 1. テレビジョン | (講師) | 7名 |
| 2. フィルム・ビデオ | (講師) | 17名 |
| 3. エンジニア | (講師) | 20名 |
| 4. テクニシャン | | 27名 |
| 5. オペレータ(サウンド等) | | 20名 |

○ UNFPA・UNESCOの共同プロジェクトでスタッフは5名。

○ 活動内容

1988年10月より開始され、国内外のジャーナリスト等を対象に人口問題に係るコミュニケーション技術の研修等を実施している。

3. NCPD 組織図

NATIONAL COUNCIL FOR POPULATION AND DEVELOPMENT

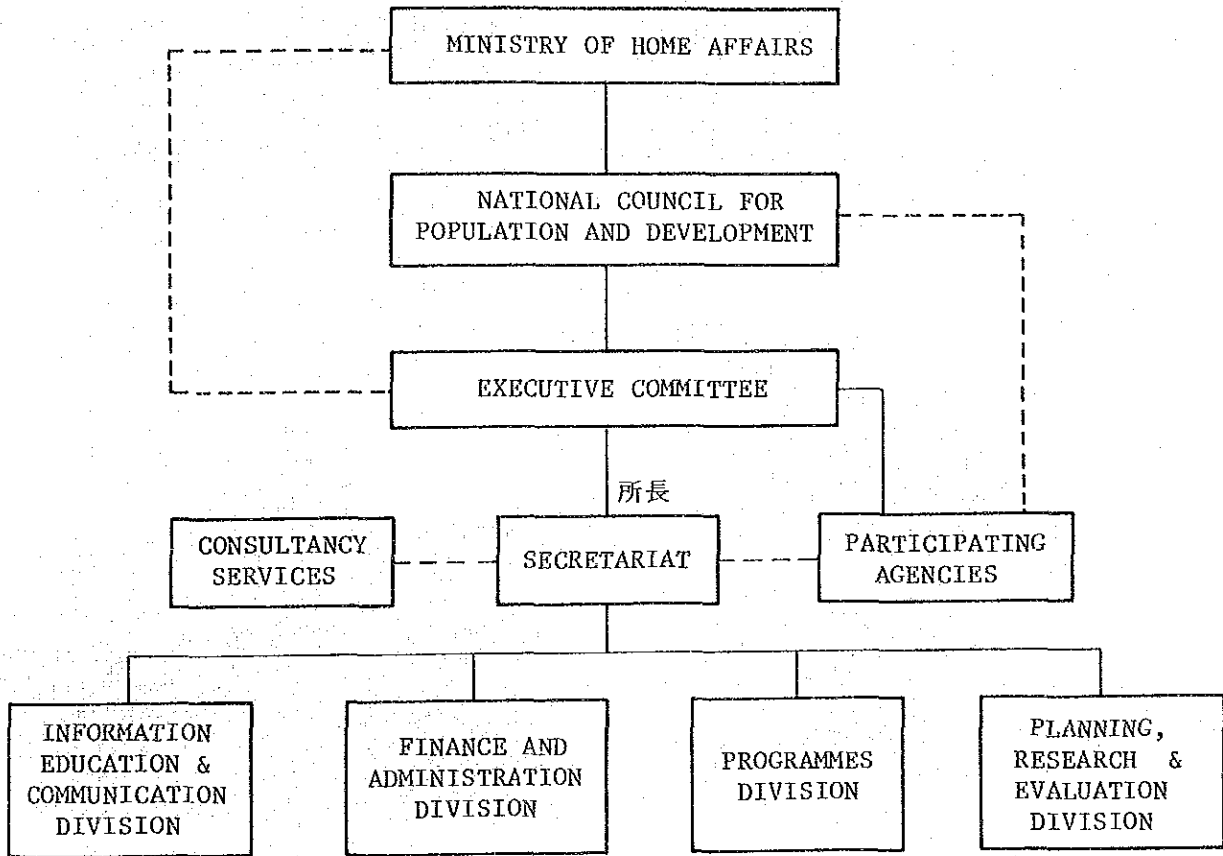

部長：W. ムネネ

職員：9名

うちカウンターパート

G. M. カブディア

M. ムインディ

Consultative -----

Functional -----

4. 機材据付専門家報告

若 林 勉 (わかばやし つとむ) (株)ティ・シー・シー 営業技術部
 飯 田 茂 (いいた しげる) (株)ソニーシステムサービス サービス技術部

1990年7月16日～1990年8月13日

作業内容 システム設置方法 工程打合せ
 木枠梱包解体 機材搬入
 ラック、モニター棚、コンソール 床固定 組立て
 ケーブル通線、ダクト加工 固定
 機器実装
 電源ケーブル布線、接続、チェック
 同軸、音声、制御ケーブル布線、接続
 電源投入、動作チェック
 総合チェック
 清掃、ペイント補修
 トレーニング

5. スタジオ位置図

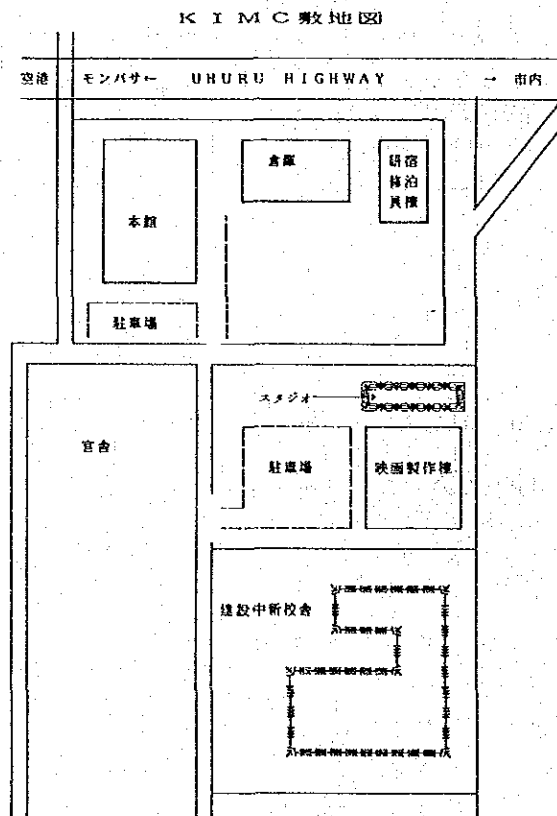

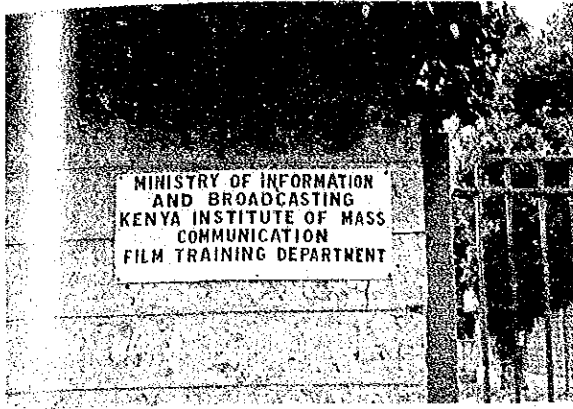

K. I. M. C (プロジェクトサイト)

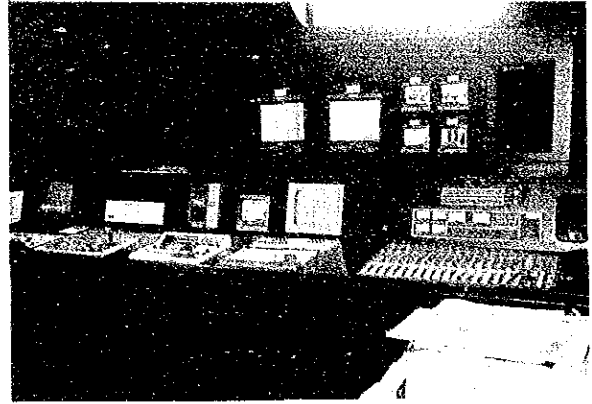

スタジオの編集設備



K I M C内にプロジェクト基盤
整備事業により建設したスタジオ

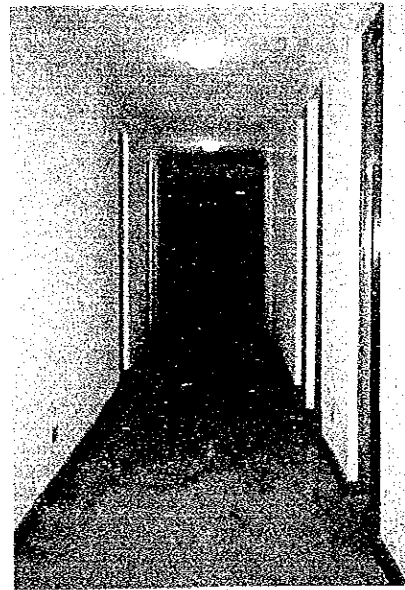

盗難防止用グリルの奥に
A V機器を設置した。



供与機材の開梱作業

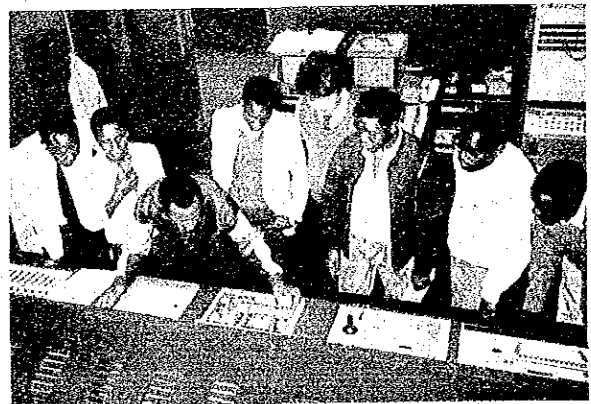

技 術 指 導

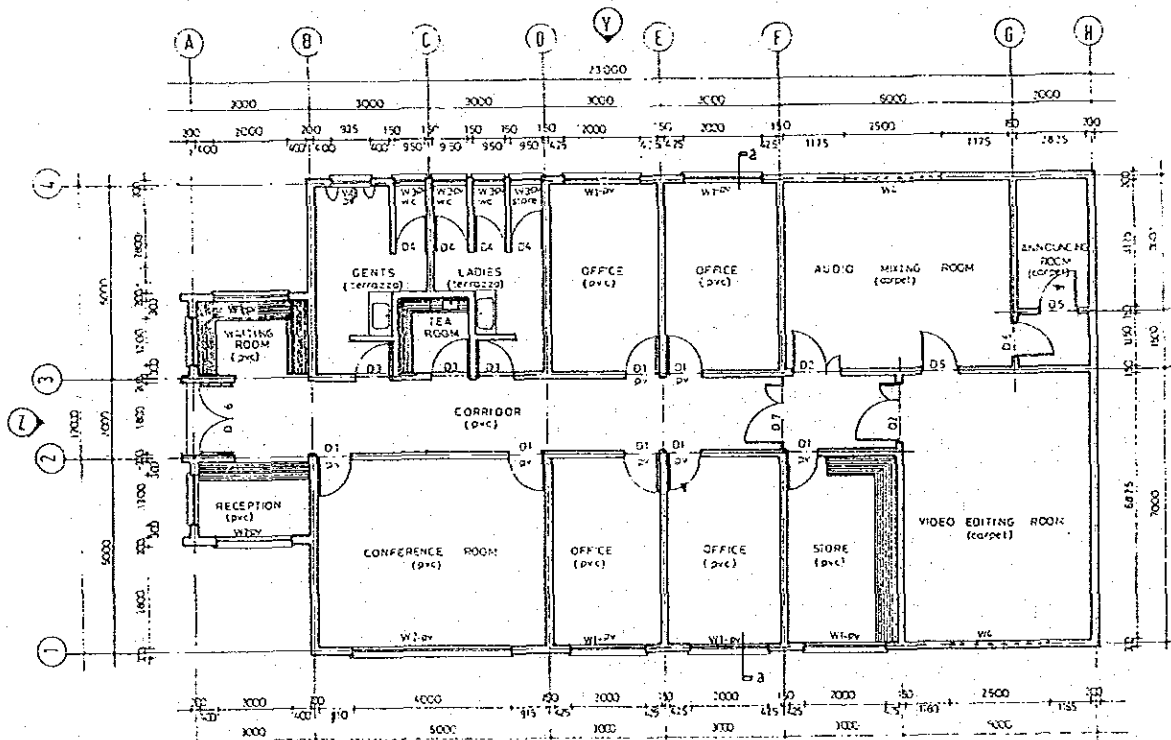
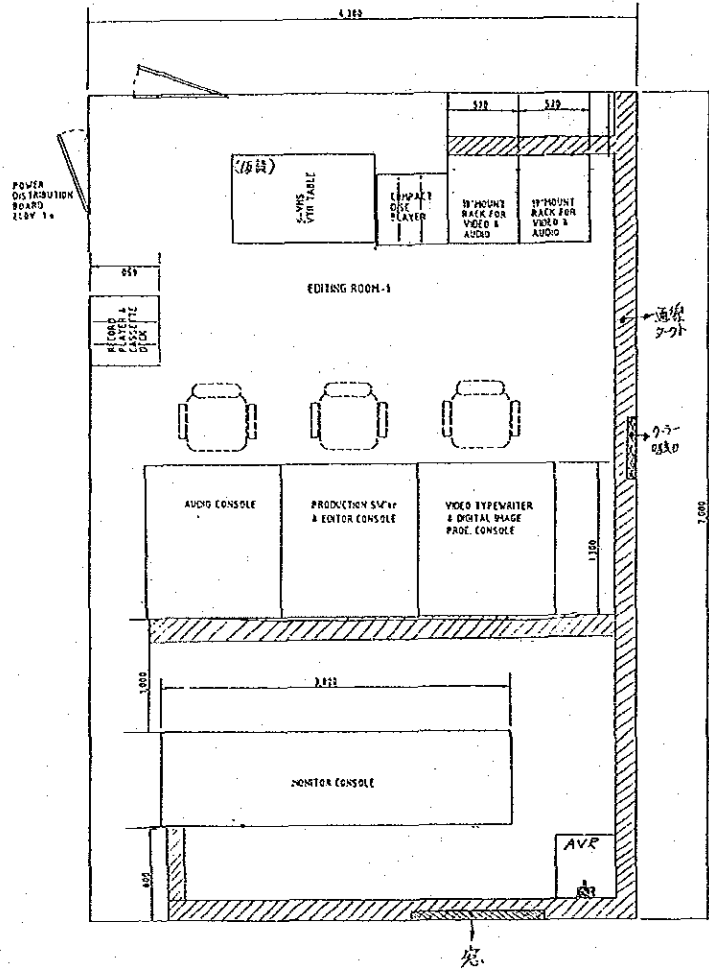

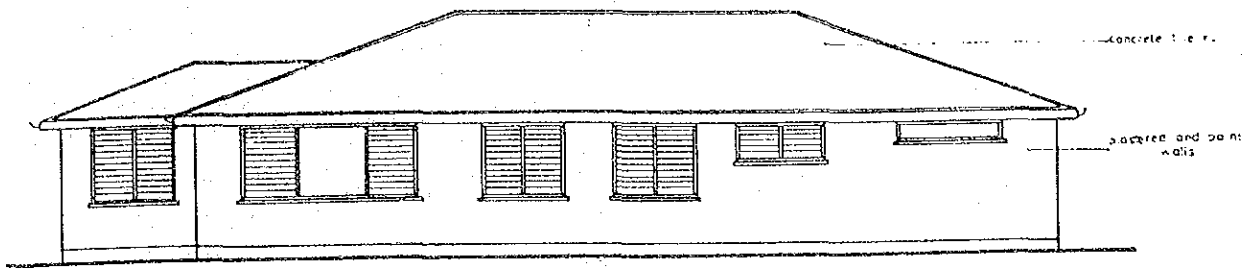

ELEVATION X 1/80

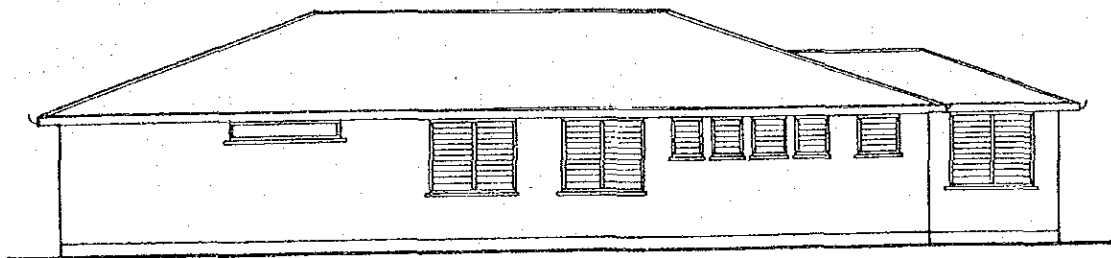

ELEVATION Y 1/80

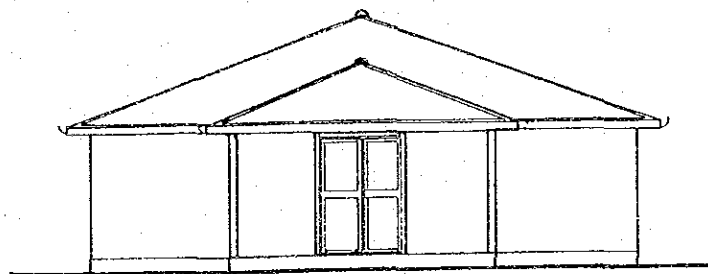

ELEVATION Z 1/80

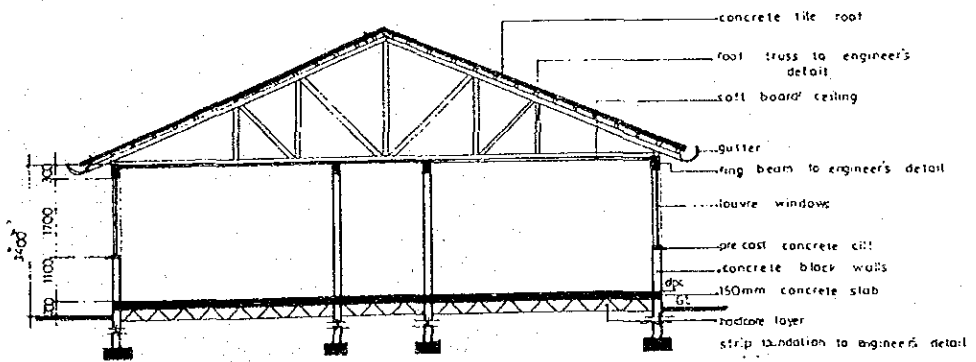

SECTION a-a 1/80

6. 主なAV機器構成

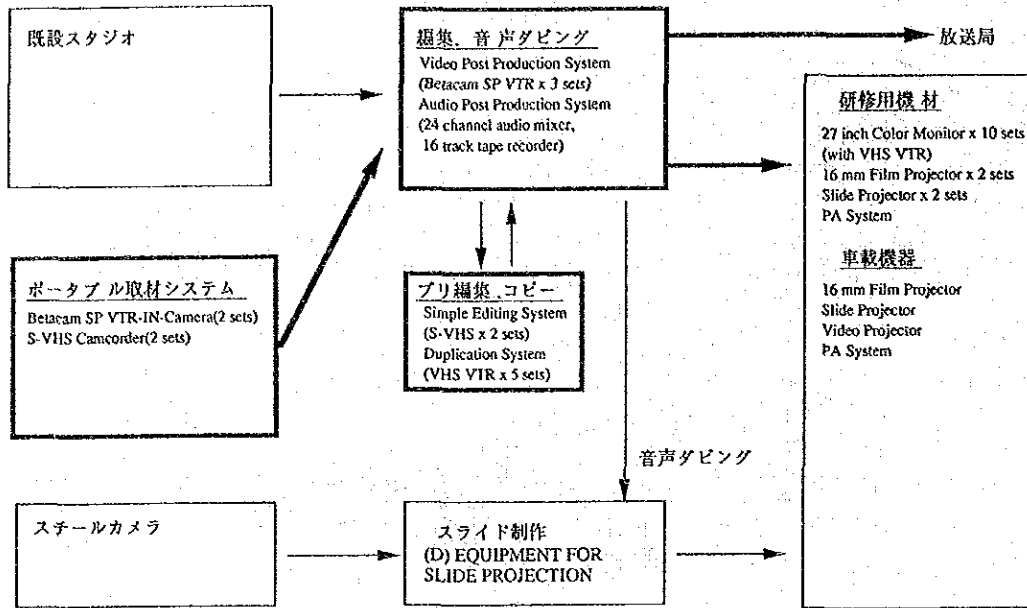

Portable Production System

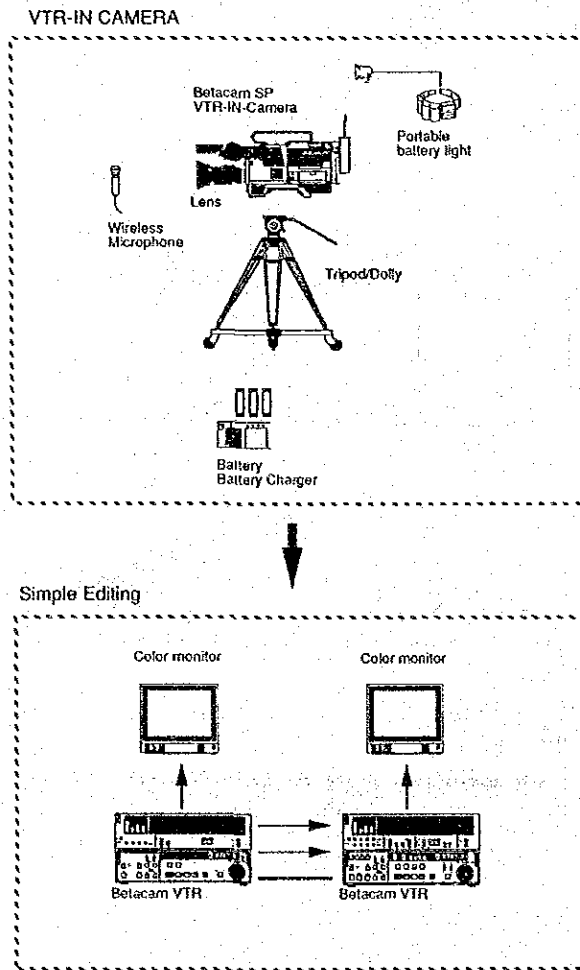

POST PRODUCTION SYSTEM

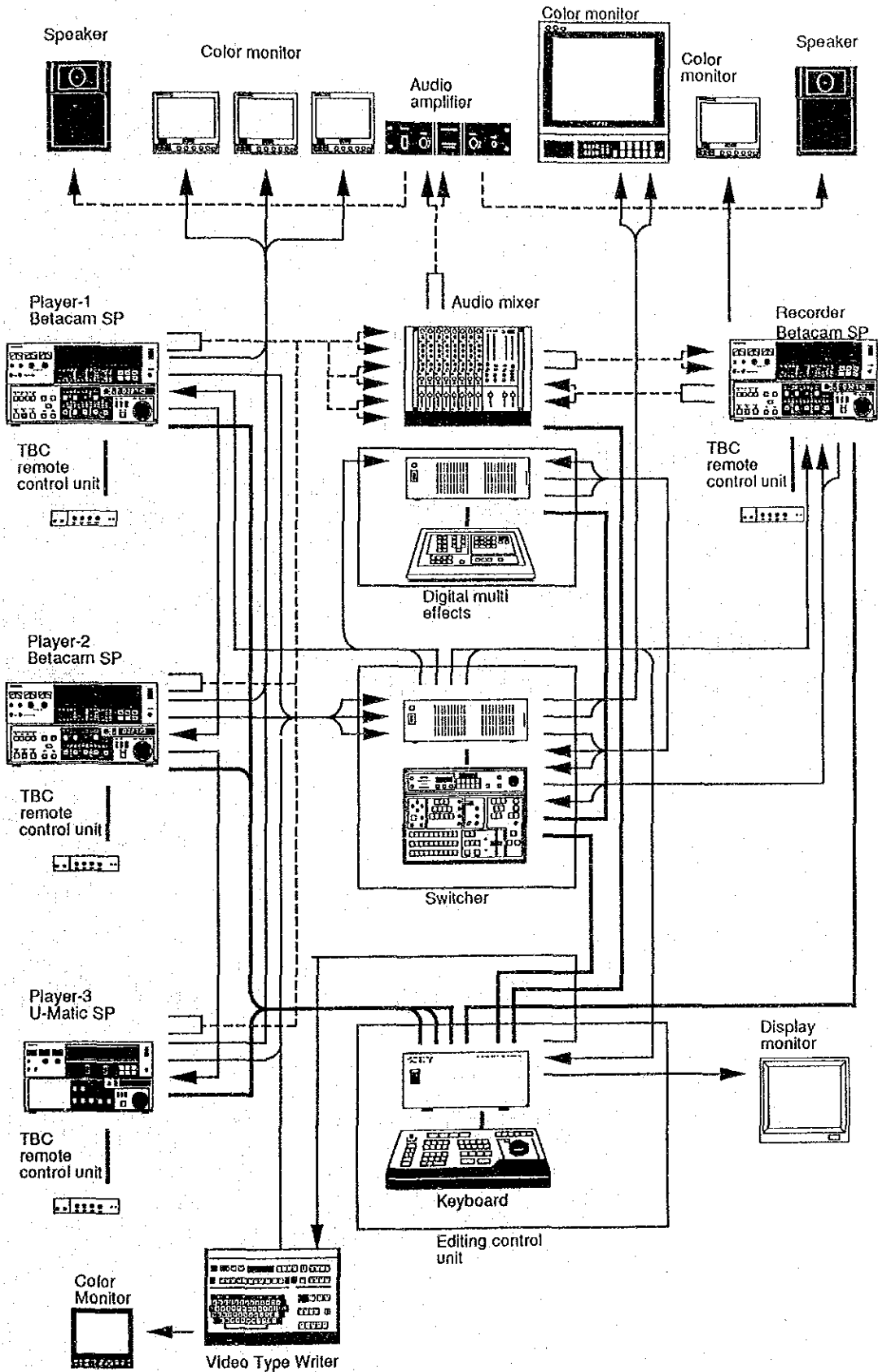

Duplication System

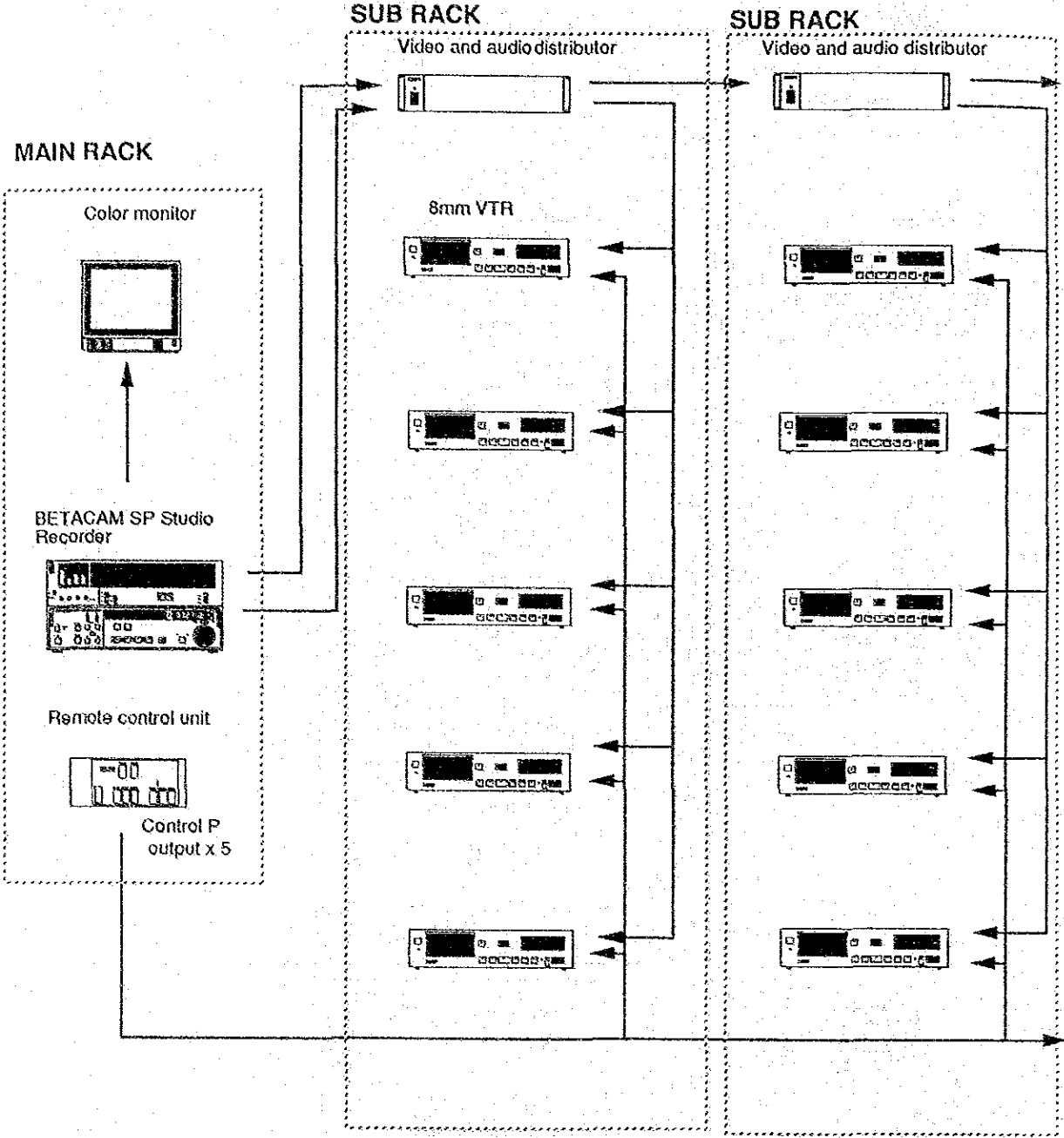

KENYA INSTITUTE OF
MASS
COMMUNICATION
P.O Box 42422

TRAINING OF TRAINERS COURSE
IN POPULATION COMMUNICATION
AT KIMC

January 23rd - March 3rd 1989

Regional Resource Centre for Population Communication
P.O Box 42422
NAIROBI

**TRAINING OF TRAINERS COURSE IN POPULATION COMMUNICATION AT KIMC
FROM JAN 23rd - MARCH 3rd 1989**

The Training of Trainers Course in Population Communication was held from January, 23rd to March 3rd 1989 at the Kenya Institute of Mass Communication. It was the first such course organised by the newly started population communication project at the institute financed by the United Nations Fund for Population Activities through UNESCO and being implemented by KIMC. It was opened by the Permanent Secretary Ministry of Information and Broadcasting Mr. Joash Adamba. The opening ceremony was also attended by Mr. Kanwar Mathur Senior Regional adviser for Unesco in Africa and Mr. Michael Hyne, UNFAPA's country representative in Kenya.

OBJECTIVES

1. To introduce the participants to content and Methodolog of Population Communication studies.
2. To introduce them to the main resource persons, centres materials and bibliography in Nairobi dealing with population and population related issues and programmes.
3. To develop together ways of introducing population communication studies into the ongoing syllabi and curricula of the institute and to develop new training programmes.
4. To develop a self conscious population communication community at KIMC for

effective coordination of the project throughout the institute.

5. To develop a core group of staff members drawn from the departments of film, information, Radio and Television training who would be involved in the Project thereafter.
6. To try out new methodologies for population communication training including lecturers, field trips, classroom discussions and the use of audio visual aids.

PARTICIPANTS

12 participants underwent the course. They comprised of 8 KIMC lecturers from the Film Department, the Radio and Television Production Department, the Information Department as well as 4 members of the Population Communication Project. They were all at the level of post graduate scholars.

CONTENT

The first part of the course was undertaken by Dr. Otieno Munala who was also the course co-ordinator. He explored the various theories of communication with particular reference to the African situation. He discussed various traditional benefits regarding the population issue. The senior UNESCO adviser for population communication for Africa Mr. Kanwar Mathur then narrowed this down to the specific area of population communication - the whole process necessary to have people adopt to new action in the very sensitive issue of population. He explored the evolution of the various approaches and their effectiveness and the factors which

limit or determine effective communication.

Prof. Oucho of the Institute of Research and Population Studies - University of Nairobi gave a number of lectures on the various concepts of population, on the structure of population in Kenya, on the measurements of population and on the determinants of fertility in Kenya.

Mr. Hyne - the country director of the United Nations Fund for Population Activities outlined the various on-going population related programmes that his fund is undertaking in Kenya through the National Council for Population and Development.

The participants then spent a whole week at the UNEP headquarters in Nairobi where several papers were presented on population and environment. They were invited observers to a workshop of leading third world journalists who have launched an international magazine on Sustainable Development.

The participants also had an exhaustive lecture by Reverend Kiarie on how the Kenya National Council of Churches looks at the question of family planning.

The Catholic point of view was also exhaustively presented by Father Raphael Wanjohi of the Kenya Catholic Secretariat. Then the participants met the whole day with officials from the Kenya Family Planning Association led by the association's national programme officer Mrs. Mukolwe. The officials discussed the history of the movement and its current outreach capability, its future expansion plans and what the organisation considered as current family planning priorities. For instance, the

Association was most keen that the Government came out with a clear policy on adolescents.

The association organised a field trip for participants to Meru some 200 Kilometres from Nairobi where they had insight into the actual situation in the heart of Kenya. It was a most rewarding trip for the participants (rate of population growth in Meru is 4.3%). The participants also made another field trip to Kaviani in Machakos where they held lengthy discussions with the officer in charge of the health clinic there as well as with the chief and assistant chiefs. Very interesting information came out of these discussions and the participants decided that Kaviani should act as one of the Population Communication project laboratories. It has the advantage that it is only an hours drive from the institute.

In the middle of the course, the participants joined a seminar at the Kenya Institute of Education for education inspectors from various parts of the country. It was to inform them of how the new syllabus on Population and Family Life Education had been worked out. It was also to acquaint them with the new syllabus and to explain to them why it had been found necessary.

The participants then resourced amongst themselves. Mr. Wangira discussed on the various stages of producing a film and Mr. Munyi discussed on how to cost a film production. Mr. Gatangi presented the various stages of research and the different reseach methodologies. Mr. Muoka discussed the craft of Television production-its strengths and weaknesses while Consolata Mocha discussed the radio as a medium of mass communication.

Mr. Joseph Dhikusoka gave an exhaustive lecture on the Folk Media and its potential for Population Communication.

And then there was a guest group led by the national director of the Kenya Deaf Association Mr. Ouma who gave some demonstrations on non verbal communications as applied by the deaf. At the end of the course, all the participants met to review the ground they had covered after which they came out with several recommendations.

METHODOLOGY

Lectures given by prominent people in various population related fields dominated the course and also gave prominence to the population content aspect as opposed to the communication aspect. This was thought proper as all the participants were professional communicators. A film on the population situation in Kenya produced by an outgoing KIMC film training department student was screened and finally, there were 2 field trips - one to Meru, 200 kilometres from Nairobi and another to Kaviani in Machakos district some 80 kilometres from Nairobi.

COURSE EVALUATION

At the end of the course the participants met to evaluate the course. They all said it had sensitised them to an issue they had previously taken for granted. Some said earlier, they had been quite convinced that the population question in Kenya was irrelevant.

They said the seminar had helped lay bare the facts and genuine concern of those actively involved in the issue. They also felt that they had gained greatly by being invited as observers to the population education seminar at Kenya Institute of Education and the Sustainable Development Conference at the UNEP Headquarters in Nairobi. They however, had complaints about 2 of the resource persons. One they felt was a scatter brain and that they could not really put down coherently his line of thinking. The other they said was either quite unprepared or outrightly confused. The rest they said had been quite impressive.

RECOMMENDATIONS

The participants then recommended the following.

1. That as it was clear that there was a population problem in Kenya, population communication be taught in depth to all communicators passing through the institute.
2. That localised research be carried out on the current methods of communication being used by various organisations involved in family planning.
3. That localised research be carried out on various target groups.
4. That inservice courses for extension groups be organised by the project so that the groups could know how to use the various media and the strengths and weaknesses of each medium for effective motivation. Such courses could be

held at the KIMC or in the field.

5. They recommended that the KIMC could play the role of consultancy for organisations involved in population issues in regard to communication.
6. They recommended that KIMC should produce population related programmes not just for training but for the Kenyan market.
7. They proposed to develop a population resource centre at the KIMC.
8. They proposed to use Vihiga, Kaviani in Machakos and if possible a sub-location in Kilifi district as their population communication laboratories.
9. They accepted the general guidelines related to the introduction of population communication studies for pre-service students at the KIMC.
10. They recommended that population communication be introduced to the pre-service students during their orientation week from the 28th of March, 1989.
11. The core members of the population communication project would develop a curriculum package for pre-service training and the in-service courses.
12. The participants recommended that all productions which will be done at the KIMC this year should be on population communication.

13. They appreciated the fact that all the organisations involved in population issues in Kenya have taken the position that after the citizen has been made aware of all the options, then the he or she will be able to make a rational choice about the kind of family he or she should have.

COURSE PARTICIPANTS

1. Job Osiako - Principal KIMC
2. Odhiambo Okite - Head of Department Population Communication
3. Judith Ogecha - Coordinator - Print/Press
4. Matu Nguri - Coordinator - Electronic Media
5. Joseph Dhikusoka - Lecturer - Folk Media
6. Patrick Wangira - Lecturer - Film
7. Eston Munyi - Lecturer - Film
8. Grace Kogondu - Lecturer - Film
9. Gideon Muoka - Lecturer - Television
10. Jedida Solitei - Lecturer - Television
11. Consolata Mocha - Lecturer - Radio
12. Levit Pereira - Lecturer - Television

RESOUCÉ PERSONS

1. Professor Oucho - Population Studies and Research Institute - University of Nairobi
2. Mr. Hyne - Country Director United Nations Fund for Population Activities.
3. Dr. Munala - General Secretary Bible Society of Kenya
4. Kanwar Mathur - Senior UNESCO Adviser on Population Communication for Africa

5. Father Wanjohi - Kenya Catholic Secretariat
6. Pastor Klarie - National Council of Churches of Kenya
7. Mrs. Mukolwe - National Programme Manager - The Family Planning Association of Kenya
8. Mrs. Kipkorir - Director - Kenya Institute of Education
9. Patrick Wangira - Lecturer - Film KIMC
10. Eston Munyi - Lecturer - Film KIMC
11. Gedion Muoka - Lecturer - Television KIMC
12. Jedida Solitei - Lecturer - Television KIMC
13. Consolata Mocha - Lecturer - Radio KIMC
14. Joseph Dhikusoka - Lecturer - Folk Media
15. Sa,ie; Gatangi - Research KIMC
16. Tom Okite - International School Nairobi
17. Dominic Ouma - National Director - Kenya Deaf Association

**SPEECH BY MR. J. ADAMBA, PERMANENT SECRETARY OF
MINISTRY OF INFORMATION AND BROADCASTING AT THE
OFFICIAL OPENING OF THE TRAINING OF TRAINERS COURSE IN
POPULATION COMMUNICATION STUDIES AT KIMC ON MONDAY
JANUARY 23RD 1989**

MR, PRINCIPAL

DISTINGUISHED GUESTS

LADIES AND GENTLEMEN

I AM QUITE DELIGHTED TO BE HERE THIS AFTERNOON AND TO OFFICIATE AT THE LAUNCHING OF THE OPENING ACTIVITY OF THIS IMPORTANT PROJECT.

MY PRESENCE HERE UNDERSCORES THE IMPORTANCE WHICH THE GOVERNMENT ATTACHES TO THIS PROJECT.

I AM EXTREMELY GLAD TO SEE IN THIS ROOM, MY COLLEAGUES IN THE GOVERNMENT AND OUR INTERNATIONAL PARTNERS WHO HAVE LABOURED TO GET THIS PROJECT UNDERWAY.

WE CAN NOW FORGET ALL THOSE DAYS OF ANXIETY, DOUBTS, DELAYS AND FRUSTRATIONS AND REJOICE TOGETHER, BECAUSE THE PATIENCE WE EXERCISED HAS PAID OFF SO HANDSOMELY.

I MUST HOWEVER HASTEN TO SAY THAT OUR PATIENCE AS A GOVERNMENT HAS RUN OUT IN RESPECT TO THE EVER ESCALATING GROWTH OF OUR POPULATION.

THIS PHENOMENAL GROWTH NULLIFIES ALL OUR EFFORTS TO DEVELOP OUR COUNTRY AND OUR PEOPLE. IT EATS INTO EVERY ASPECT OF OUR ECONOMY. WE MUST THEREFORE DEMAND THAT ALL THE PROGRAMMES THAT THE GOVERNMENT HAS LAUNCHED TO REMEDY THE SITUATION SHOULD BEAR CONCRETE RESULTS. THE COUNTRY'S BIRTHRATE MUST BE HALTED AND REVERSED. THIS MUST BE DONE THROUGH PERSUASION NOT THROUGH FORCE. THIS IS IN KEEPING WITH OUR POLITICAL CULTURE, A CULTURE WE HAVE DEVELOPED WITH GREAT PATIENCE AND WHICH WE MUST GUARD JEALOUSLY.

IT IS IN THIS CONTEXT THAT WE VIEW THIS PROGRAMME WHICH IS DESIGNED TO TRAIN PERSUADERS TO BECOME KNOWLEDGEABLE IN POPULATION COMMUNICATION. THE PROGRAMME SHOULD ALSO TRAIN POLICY MAKERS, ADMINISTRATORS AS WELL AS GRASSROOT WORKERS IN THE POPULATION AREAS, TO APPRECIATE THE ROLE OF THE MEDIA OF COMMUNICATION IN PROPAGATING THE POPULATION MESSAGE. I WISH TO COMMEND THE MANAGERS OF THIS PROJECT FOR THIS EXCELLENT PROGRAMME WHICH IS DESIGNED TO TRAIN FIRST OF ALL THE TRAINERS AND TO GIVE THEM APPRECIATION OF THE BREATH AND DIVERSITY OF THE FIELD THEY HAVE TO HANDLE.

I HAVE ALWAYS FELT THAT THE INSTITUTE SHOULD NOT ONLY TRAIN IN THE CRAFT OF MASS MEDIA COMMUNICATION BUT THAT IT SHOULD ALSO GET INVOLVED IN TRAINING IN DEPTH IN SPECIFIC CONTENT AREAS SUCH AS NATIONAL DEVELOPMENT, ENVIRONMENT,

POPULATION AND OTHERS, SO THAT WE CAN HAVE SPECIALISED SPOKESMEN FOR THESE AREAS OF CONCERN TO THE COUNTRY.

I KNOW WE DO NOT HAVE ENOUGH JOURNALISTS AND THAT WE MUST CONTINUE TO TRAIN THE JACKS OF ALL TRADES.

WE MUST ALSO TRAIN SPECIALISTS WHO HAVE MASTERED THE TECHNIQUES OF MASS COMMUNICATIONS AS WELL AS THE CONTENTS OF SPECIFIC DISCIPLINES.

THIS REALLY CALLS FOR NEW THINKING AND NEW ORGANISATION OF THIS INSTITUTE. KIMC MUST BEGIN TO TRAIN INTERDEPARTMENTALLY. FOR EXAMPLE, A TRAINEE WHO IS TO BE A COMMUNICATOR SHOULD KNOW SOMETHING,

TO DO WITH JOURNALISM, FILM, RADIO AND TELEVISION AS WELL AS POPULATION. THIS KIND OF THINKING AND ORGANISATION SHOULD ENABLE KIMC TO SERVE OTHER MINISTRIES AND THE PRIVATE SECTOR.

THERE WILL BE DEMANDS SOONER OR LATER FOR COMMUNICATORS WITH A STRONG BIAS TOWARDS POLITICAL JOURNALISM, ECONOMIC JOURNALISM, CULTURAL CRITICAL REVIEW, SCIENCE AND TECHNOLOGY, REPORTING AND OTHERS. POPULATION COMMUNICATION STUDIES SHOULD ALSO ASSIST IN HIGHLIGHTING THE NEED FOR KIMC TO INTRODUCE SERIOUS STUDIES IN NOW CONVENTIONAL AND TRADITIONAL AFRICAN METHODS OF COMMUNICATION, AS THE MINISTER SO EMPHATICALLY POINTED OUT HERE AT THE END OF NOVEMBER LAST YEAR. POPULATION IS A SENSITIVE AND PERSONAL ISSUE WHICH MODERN MASS MEDIA ALONE CANNOT DEAL WITH EFFECTIVELY.

THE SUBTLE MESSAGES AND THE SOPHISTICATED HUMOUR OF THE FOLK MEDIA ARE FAR MORE ADEPT AT TRANSMITTING SUCH INTIMATE INFORMATION AS FAMILY PLANNING METHODS.

THE EFFECTIVE DEVELOPMENT OF THE FOLK MEDIA CURRICULUM WITHIN KIMC WILL GREATLY STRENGTHEN ITS TOTAL PROGRAMME.

THE GOVERNMENT HAS EXPRESSED ITS TOTAL SUPPORT FOR THE PROJECT BY ASSIGNING TO IT HIGHLY QUALIFIED AND EXPERIENCED STAFF, BY GIVING IT ADEQUATE SPACE FOR ITS IMPLEMENTATION, BY FULLY MEETING ITS FINANCIAL OBLIGATION TO IT AND BY PROVIDING ALL POSSIBLE BACK-UP FOR IT.

LET ME NOW TURN BRIEFLY TO THE COURSE WE ARE LAUNCHING TODAY. I WISH TO COMMEND YOU ALL - YOUNG AND OLD - WHO HAVE SIGNED UP FOR THE COURSE. THIS IS A CLEAR INDICATION OF YOUR OWN DETERMINATION TO SUPPORT THE PROJECT AND TO ENSURE THAT IT SUCCEEDS.

FOR SOME OF YOU, THIS WILL BE THE FIRST TIME YOU FIND YOURSELVES IN CLASSROOM, BEING LECTURED TO INSTEAD OF LECTURING. YOU WILL FACE ASSIGNMENTS AND HOMEWORK AND THE THREATENING FINGERS OF THE MASTER.

ALL THIS IS GOOD FOR ANY LADY AND GENTLEMAN OF SUBSTANCE. WHAT YOU DO UNTO OTHERS, MAY BE DONE UNTO YOU AND LET GOOD HUMOUR PREVAIL, AND LET SERIOUS KNOWLEDGE BE PASSED ALONG. I NOW HAVE GREATEST PLEASURE AND HONOUR TO DECLARE THIS COURSE OFFICIALLY OPEN.

**KENYA INSTITUTE OF MASS
COMMUNICATION**

**POPULATION COMMUNICATION
COURSE FOR NEWLY RECRUITED
GRADUATES AT THE KENYA
INSTITUTE OF MASS
COMMUNICATION FROM 9TH - 20TH
MAY 1989**

*Resource Centre for Population
Communication
P.O Box 42422
NAIROBI*

POPULATION COMMUNICATION COURSE FOR NEWLY RECRUITED
GRADUATES AT THE KENYA INSTITUTE OF MASS COMMUNICATION FROM
9TH - 20TH MAY 1989

INTRODUCTION

This was a sandwich course organised for newly recruited graduate information officers where they had been undergoing an induction course at the KIMC for the previous months before they started their reporting duties in the Ministry of Information and Broadcasting. It was organised by the Population Communication Project at the Institute funded by the United Nations Fund for Population Activities, executed by UNESCO and which is being implemented by the Kenya Institute of Mass Communication.

OBJECTIVES

1. To expose 16 newly recruited Information Officers to the issue of population as a critical variable in national planning and the development process.
2. To expose them to the serious concern that the nation is giving to the high population growth rate vis-a-vis the resources available as well as the rate of which resources can be developed.
3. To make the officers sensitive to the question of family planning in relation to the health of the mother, that of child as well as other human dimensions of family planning.
4. To explore with them how the various media can be used for population communication.

COURSE CONTENT

1. Population Studies
 - (a) Population concepts
 - (b) Population measurements
 - (c) Determinants of fertility
 - (d) Sources and uses of population data

2. The national population policy
 - (a) History and establishment of the National Council for Population and Development
 - (b) The current involvement and activities of the NCPD
 - (c) Some insights into the Family Planning situation and government sensitivity over contraceptives for the youth.

3. The Family Planning Association of Kenya
 - (a) The history of family planning in the country and the development of the movement.
 - (b) The association's policy and emphasis
 - (c) The contraceptive methods and preferences in Kenya
 - (d) Counselling in family planning clinics.

4. The Catholic Church's position on family planning
 - (a) Is family planning a priority?
 - (b) Contraceptive imperialism

4. (c) Erosion of Morality
 - (d) Natural family planning
 - (e) Abortion

5. Population and Environment

6. Population and Genetic Resources

7. Population, Women and Development

8. Using television for population communication

9. Using Radio for Population Communication

10. Using Folk media for Population Communication

11. Using magazines for population communication.

12. The 1989 national census

METHODS

Through sensitivity and encounter sessions with 15 resource persons from key national organisations involved in the population issue; through teaching aids such as films, video and audio programmes, through graphs and pyramids. There were practical assignments, each participant given the responsibility of filing a news report on specific session. Most of these made their way to the national media - the newspapers and the radio.

It had also been planned that the officers would pay a field trip to Kaviani - one of the Population Communication projects field laboratories - to explore practically what they had learnt. The trip had however to be dropped at the last minute due to lack of funds.

COURSE EVALUATION

At the end of the course to discuss with the Participants:

1. What new areas they had learnt
2. What they had thought most productive
3. To plod at the contraceptive controversy especially as centred on the youth.
4. How they felt they could participate in population communication as part of their work in the districts.
5. The shortcomings in the way the course had been organised.

THE RESPONSE

1. The participants felt the course had been intense and exciting. They said the population issue had been distant but had now been brought into focus. They were in agreement that there is not only a population explosion in Kenya but that there is an explosive population with catastrophic characteristics.
2. They felt the period had been too short and suggested follow-ups for deeper analysis.
3. Most felt the catholic church's position was the most provocative and the one which aroused the most debate even outside their course time.
4. Three of the participants said they were already working on news features on the course. Others said it will be possible to write well researched articles in the districts on population. There were also ideas that they could carry out audience profiles and responses on population programmes carried out by the media; in a particular district with such questions as what age group listens to what programme on radio; is the scheduling of the programmes appropriate for the targeted group: what language would the local people mostly be willing to listen to - the 2 national languages or the vernacular. They could carry out research and advise on the proper scheduling time for the young, for the old and even the proper season of the year. They could also monitor and counsel on the type and display of national or local posters - their appropriateness and advise on whether it might be better to use actual photographs of local people whom the locals might identify with.

Another idea was that as the communication expert in the district, the information officer should offer consultancy services to groups and organisations dealing with the population question. An example could be discussing persuasion models with the family planning volunteers working in the village and counselling people to adopt family planning, such people have practical experience but they could benefit from what experts say inhibit the communication process. It was noted that all this is a definition of a new additional role for an information officer working in the district for the centre, and thus only motivating the local people he has given exposure to in the national media - only indirectly. In the new additional role, the information officer would be acting not merely vertically from the district to the centre but also horizontally and thus enabling the local people to benefit directly from this professional skills as a communicator. It is important to note that this enables the information officer to participate more actively in the Governments district focus strategy for rural development - Kenya's blueprint for decentralisation as much as the other professionals are able to.

APPENDIX

A. Resource Persons:

- Prof. John Ocho
Population Studies and Research Institute
University of Nairobi
P.O Box 30197
NAIROBI

- Mrs. Jennifer Mukolwe
Family Planning Association of Kenya
P.O Box 30581
NAIROBI

- Miss Dorcas Kun'gu
National Council for Population and Development
P.O Box 30520
NAIROBI

- Dr. Edda Gachukia
National Adviser to Unesco
P.O. Box 30592
NAIROBI

- Mr. Abel Ndumbu
Chairman
Development Horizons Trust
P.O Box 58933
NAIROBI

- Prof. Ndeti
University of Nairobi
P.O Box 30197
NAIROBI

- Father Wanjohi
Kenya Catholic Secretariat
P.O Box 48062
NAIROBI

- I.B. Peters
UNFPA
P.O Box 30128
NAIROBI

- Eunice Mathu
Parents Magazine
P.O Box 50795
NAIROBI

- Ms. Jedi Solitei
Lecturer - Television
Kenya Institute of Mass Communication
P.O Box 42422
NAIROBI

- Tom Kazungu
Deputy Head
National Service
Voice of Kenya
P.O Box 30456
NAIROBI

- Henry Wahinya
Kenya Red Cross Society
P.O Box 407
NAIROBI

- Consolata Mocha
Coordinator - Folk Media
Resource Centre for Population Communication
P.O Box 42422
NAIROBI

PARTICIPANTS

1. Nellie Munala
2. Monica Mwangi
3. Athman Amran
4. Agnes Omolo
5. Jane Muthura
6. Munene Ruigi
7. Agaro Gwaro
8. Davis Mwandembo
9. Gerald Kimari
10. Johnstone Mwololo
11. Sophie Muluka
12. Simateri Tirop
13. Kigaga Maina
14. Martin Maina
15. Juan Simba
16. Samson Raiji

Kenya Institute of Mass
Communication
P.O Box 42422
Nairobi

**REPORT ON THE CERTIFICATE IN
POPULATION COMMUNICATION
MANAGEMENT COURSE
24th July - 15th August**

*Regional Resource Centre for Population Communication
P.O Box 42422
NAIROBI*

REPORT ON THE CERTIFICATE COURSE IN POPULATION
COMMUNICATION MANAGEMENT 24th July - 15th August, 1989

INTRODUCTION

This was a certificate three weeks course on *Population Communication Management* held at KIMC from the 24th July to August 15th 1989. It was organised and executed by the Population Communication Project at the KIMC and was by and large financed by Unicef.

OBJECTIVES

At the end of the course, the participants were to be able:

1. To recognise the interaction and delicate balance between human and material resources and the need to co-ordinate these resources to ensure integrated social economic development and to enable them to intergrate this knowledge into their day to day work.
2. To give the participants an appreciation of the human dimension of the

population question and to appreciate the special skills needed to communicate this effectively at the grassroots level.

3. To enable the participants appreciate the specific resources and challenges of providing an effective answer to the population question in the districts.

PARTICIPANTS

The course was organised for District Information Officers particularly from districts with high child mortality rates. This course's participants were drawn from Mombasa, Kwale, Baringo, Kitui, Embu, Kisumu , South Nyanza and Nairobi. In addition, there was a participant from the NCPD and another one from the JICA. The course was pitched at the post graduate level because of the vast field of experience which the participants had.

COURSE CONTENT AND RESOURCE PERSONS

1. *"The situation of women and children in Kenya"* - By head of planning Unicef
Dr. Odada
2. *"Sustainable Development"* - By Chairman Development Horizons Trust
Mr. Abel Ndumbu
3. *"Introduction to the Regional Centre for Population Communication"* - By
Project manager Mr. Odhiambo Okite
4. *"Health behaviour experiences in influencing community health activities"* - By
Mr. Ely Oduol - Unicef
5. *"Examples of population media - use of Folk Media to communicate population
issues in Kenya"* - By Consolata Mocha
Population Communication Project KIMC
6. *"Population and Development, the role of the National Council for Population
and Development"* - By Dorcas Kungu NCPD
7. *"Attitudes and child rearing in various communities in Kenya"* - By
Prof. E . Oyugi
Kenyatta University
8. *"Examples of Population media; radio as a population medium in Kenya"* - By
Mr. Tom Kazungu, Producer Population
Programmes VOK
9. *"Beyond awareness"* - Mr. J.A. Johnston Regional IEC Adviser
UNFPA
10. *"Counselling"* - By Dr. Mumbi Gakuo Kenyatta University
11. *"The image of women and children in the Kenyan Media"* - Panel discussions
By Eulalia Namai Unicef
Mrs. Lena Osaga, Editor of a Children's
Magazine, Dr. Edda Gachukia Kenya's
Adviser to Unesco and Dr. Mumbi Gakuo
12. *"Examples of Population Media, TV as a population in Kenya"* - By
Mr. Gideon Muoka, Head of Television
Training in KIMC

13. *"Population Dynamics "* - By Prof. John Oucho, Nairobi University
14. *"Examples of Population Media and Film as a medium of Population Communication in Kenya"* - By Albert Wandago, Senior Lecturer, Film Training Department
15. *"Women in Development"* - Unicef Consultant Dr. Riria Ouko
16. *"Children's rights in Kenya, Key issues present legal status and initiative related to the UN convention"* -By chairman ANPPCAN Kenya Chapter Mr. Lee Muthoga
17. *"Examples of Population media, rural press possibilities"* - By Mr. James Akenga, Assistant Director of Information
18. *"Genetic resources"* - By Louis Kangethe, KENGO
19. *"The environment and overpopulation"* - By Mary Karanja, Kenya Environment and Human Settlement Secretariat
20. *"Examples of Population Media; Population Communication Research"* - By Mr. Odhiambo Okite, Population Communication Project Manager - KIMC
21. *"The Presidential Commission on soil and Water conservation"* - By Mr. S.N. Njoroge
22. *"The relationship between population and basic needs"* - Mr. George Odenyo Principal Economist, Ministry of Labour
23. *"Population as a public issue"* - Panel Discussion - By Mr. S. Mwenesi, Legal Director KANU Secretariat, Prof. Oyugi, Kenyatta University and Mrs. Ruth Nguchu, KIE
24. *"Examples in population media; Social marketing "* - By Mr. Z. Syongo, Managing Director, Print Displays.

25. *"Examples in population media; mass media theories and their impact on population communication in Kenya"* - By Wachira Kigotho - Senior Lecturer, Department of Information training. KIMC
26. *"The NCCCK position on Family Planning"* - By Rev. D. Kiarie - NCCCK
27. *"Population and Social Development"* - By Mr. David Kamau, Head of Production Training Department, KIMC
28. *"The Family Planning Association of Kenya"* - By the Head of Programme Division - FPAK
Mrs. Jennifer Mukolwe
29. *"Is the media making any impact in the family planning campaign"?*
By Dorothy Kweyu Munyakho
Freelance journalist
30. *"Mass communication experiments elsewhere"* - By Dr. J.A. Johnston
Regional IEC adviser UNFPA

METHODOLOGY

During this course, the population communication project tried two innovations from previous inservice courses. At the end of each day there was a session where the participants produced population communication media materials through a newsletter, that ran on daily throughout the course. In addition they rehearsed a folk media population communication play which was recorded for radio at the end of the course. The participants also sat through animation sessions and were shown how several themes could be animated and also illustrated through painting. The second innovation was the introduction of panel discussions. Three of these were planned, each at the end of each week, and as a climax of what had been discussed that particular week for the weeks were arranged thematically. These proved to be most popular and most insightful, particularly the first one on the image of women and children in the Kenyan media. Also, each morning, the course would start the day by focusing on a specific communication medium and how it can be made to serve the people in all the important population issues. It is to be noted that, most of the papers presented found their ways to the newspapers and the radio, written by the participating journalists. One of the project co-ordinators. Consolata Mocha also ensured that everything was audiolly recorded, several radio programmes have been made and aired on the Voice of Kenya radio. Some are projected for airing up to December.

Lastly, a field visit to Kakamega was organised for the participants from August 10th to the 13th, in which they visited the Family Planning Clinic at Kakamega town, had lengthy discussions with the DC and the District Population Officer, on the unique problems in the district in regard to the population question. They visited the rural press at Vihiga and the field visit climaxed with a spirited discussion with town elders on population and family planning.

COURSE EVALUATION

At the end of the course, the project staff had a meeting with the participants. They said the course had been very interesting and had awoken their attention to several issues connected with the population question. They said they had learnt a lot and would see how they could be of use when they get back to their districts. They asked that the project should make followups with them in any initiative it might come up with. They however complained that the course had too much crammed into it. They felt that there should have been less papers, to allow for more population media productions and discussions. They noted that, in most of the days, they were finishing their productions at 7 p.m.

PARTICIPANTS

- | | |
|---------------------|-------------|
| 1. Miss. J. Musyoka | - Mombasa |
| 2. F.W. Ndegwa | - Kwale |
| 3. D. Ethangata | - Baringo |
| 4. S.M. Ogada | - Kitui |
| 5. K. Marangu | - Embu |
| 6. J.W. Ndungah | - Kisumu |
| 7. C.K. Mmasi | - S. Nyanza |
| 8. J. Nyaribo | - Kisumu |
| 9. N. Ng'anga | - Nairobi |
| 10. M. Muindi | - NCPD |
| 11. P. Wangira | - JICA |

SPEECH BY MR. M. BAQUER NAMAZI
UNICEF REPRESENTATIVE, KENYA

ON

THE OPENING OF KIMC COURSE IN
POPULATION MANAGEMENT
24 JULY 1989 AT 9.00 A.M

The Director of Information, Mr. Musandu,
The Principal of KIMC, Mr. Osiako
Distinguished colleagues, Ladies and Gentlemen

We feel extremely pleased to be with you here today at the official opening of this first Population Communication Management Course at the Kenya Institute of Mass Communication. It is indeed a pleasure for the United Nations Childrens Fund to have this opportunity to participate in a serious gathering of this nature and to exchange ideas once again with those of you charged with the demanding responsibilities of information work at district level. UNICEF's support for this course reflects our commitment to strengthening our working partnership with you as part of our second five-year programme of collaboration with the Government of Kenya on programmes for child survival and development. This is a time for us to ask ourselves questions and challenge old approaches to communication. It is a time to evolve new strategies for reaching the vast majority of people who still today, despite revolutionary advances in communications technology, remain out of reach, or if reached, still unconvinced of the value to them of new ideas on how they can improve their own and their children's chances for survival and development.

Globally, and in Kenya, UNICEF supports government programmes for child survival and development. The GOK/UNICEF programme of collaboration is now in its second phase, coinciding with the 6th National Development Plan through which we are working at macro-economic, national programme includes support for a host of projects under the umbrella of Primary Health Care in the areas of immunization, diarrhoeal disease control, nutrition, growth monitoring, maternal health, control of sexually transmitted diseases including AIDS, and family planning and population. Other national programme support is to basic education which includes pre-school and early childhood care and development health education in primary schools and functional literacy for adults. Women-in-Development is another concern nationally, as is social planning and institutional capacity building. All national programmes are integrated and when applied in a district, constitute what we call the area-based programmes for child survival and development. The 1989/93 plan of operation includes Kwale, Baringo, Kitui, South Nyanza, Embu and Kisumu districts, and Nairobi, Kisumu and Mombasa municipalities. Our target population, defined as those groups most at risk, is approximately five million people, or about 25% of the total Kenyan population.

Underlying all of our programmes is the need for community participation and social mobilization. UNICEF's work in developing countries since the 1950s has been, and continues each year to be, a learning experience for us in terms of that most vulnerable groups at community level, that is, those at greatest risk of dying or being disabled from preventable causes. And here I am talking not only about the availability of health services that will benefit children and their families, but also of the acceptability of those services to the people. I'm talking about creating demand for something new and different. But before any of that is possible, there must be a change in some of the most personal and intimate aspects of thinking about our bodies and our personal behaviour: what we eat, how we clean ourselves, even how we sleep. Let us not for a moment forget the sensitivity of these subjects and really, who are we as communicators, as social workers, community development officers, even as doctors to tell others what to do in their homes? On the other hand, our approach must be, not to tell, not to dictate - experience has shown that it just doesn't work - but instead, to discuss, to listen, to first understand and appreciate other's attitudes and behaviour and the reasons for them. Then, through identification of problems and aspirations, we can put words and pictures to the desired goals and come up with messages that will effectively touch the hearts and minds of our target audience and eventually lead to changes in behaviour.

A senior communication expert from Sri Lanka who worked for many years with UNICEF throughout the developing world, visited our office last year before his retirement and made a striking remark which many of us have never forgotten. He was talking of the great difficulty and challenge of changing health behaviour and he reviewed with us, some of the earnest efforts on the part of medical and media experts alike, to persuade people to accept and adopt new knowledge and technologies to improve the lives of their children. He was also discussing the same very difficult topic you will be focussing on here, population and messages to convince parents to limit the size of their families. "What I have learned," he said, "after many false starts, was that when all is said and done, family planning is a matter of the heart, not of the uterus. Until a mother feels the real value to herself and to her surviving children of a smaller family, all the family planning devices and practice and arguments in the world won't make a bit of difference. And, needless to say, but sometimes overlooked, her husband has to have a change of heart, too.

Here is our common challenge then, for you and us and all our partners in development programmes. We want to enlighten parents and school children, too -- we want to empower them with the tools of knowledge about the services available today in Kenya and about the action they can take even at home to improve their health, and hence their potential for a fuller life. Our challenge is to reach the hearts and minds of parents, with the facts that can improve their lives, and to introduce and present those facts, in a way they will understand and accept.

To do this more effectively than we have managed to do in the past, I believe we need to do much more, to encourage real dialogue with the recipients of our messages in a two-way process of communication. We already enjoy effective dialogue with our colleagues in government at the planning stages of all our programmes for child survival and development. And in the implementation stage of supporting, for example, immunization programmes and early childhood education, or women's income-generating projects or water and sanitation programmes, there is healthy dialogue at national and district levels. But when it comes to real communication, two-way communication with the recipients of our messages -- with those, in fact, most in need of the services and the knowledge -- we still have a long way to go. I would like to suggest to you today, that during the course ahead, you consider the dynamic, two-way aspect of communication -- the participatory interactive process that is necessary in any debate. For, it is often a debate we are engaging in, is it not? Although the other partner may maintain polite silence, in her or his mind he or she is always weighing what we say against habit, custom, and what mother used to do. We are all victims of this mental process when challenged, and I dare say our first response is to disbelieve, to doubt, or to regard with suspicion any new ideas being preached.

If we keep more firmly in mind the two-way dimension of communication, we may find that we are not able to design our posters or our written messages from our desks alone, or from theoretical approaches stemming from our individual educational backgrounds. Indeed, the packaged, globally-designed messages we may receive from organizations like UNICEF or WHO or UNFPA can at best be only a pre outline of a design we must colour in, and even dramatically change, to suit the habits and ideas prevailing in our districts.

One of the objectives of your course states that it should give participants "an appreciation of the human dimension of the population question to appreciate the special skills needed to communicate these effectively at the grassroots level. And a key "special skill". I venture to suggest, is to listen more to the people we are communicating with and encourage them to speak out their doubts and fears before we present our messages. Unless we truly understand their perception of the situation and unless they feel we care about their attitudes, we'll never touch their hearts with our messages. I believe my colleagues in the Ministries of Health, Education and Culture and Social Services would agree that this is the biggest single challenge we have in our programme work for children, whether we are talking about sustaining immunization programmes, diarrhoeal disease control, preventive measures against malaria, monitoring growth and enhancing nutrition levels, reducing the spread of AIDS, encouraging parents to bring forward their disabled children for rehabilitation, or spacing child births.

In addition to your role as communications with the people at all levels in your districts, I would also like to highlight here your equally important role as participants in the development process itself, for as you identify problems and understand attitudes at community level, you are ideally placed to communicate these to those of us who are less closely in touch with the people. A key dimension of UNICEF's area-based programmes is feedback from the participants and the receivers, and just as a two-way flow of ideas between you and the recipients of your messages is vital, so, too, is the flow of ideas between you and the government departments and agencies who try to measure the impact of their programmes and modify where necessary. Your contribution is essential in order for the rest of us to design programmes that are truly district-specific and responsive to local needs.

And finally, I would like to challenge you today to consider more effective channels of communication at district level. Once appropriate messages are designed, how can we widen our distributions that more people can receive those messages? You are all working at the district level where you can communicate, not only through the conventional media, but also through other institutions like local administration, KANU, religious bodies, teachers, women's groups and NGOs active in a number of our communities. And let's not forget school children either. Stories based around health messages can often reach mothers fasterst on the tongues of their own children.

I have been talking quite a bit here about two-way communication, about real dialogue, about designing and disseminating information that will have impact, that will move and convince people and help change behaviour. Not an easy talk, but a possible one. It is our hope that we can start this process with you, by making you as concerned as we are during this course about the problems, and as excited as we still are -- despite the obstacles -- to the absolutely realizable solutions which are within our reach today.

Thank you.

8. IEC車図面等 (平成元年度供与機材)

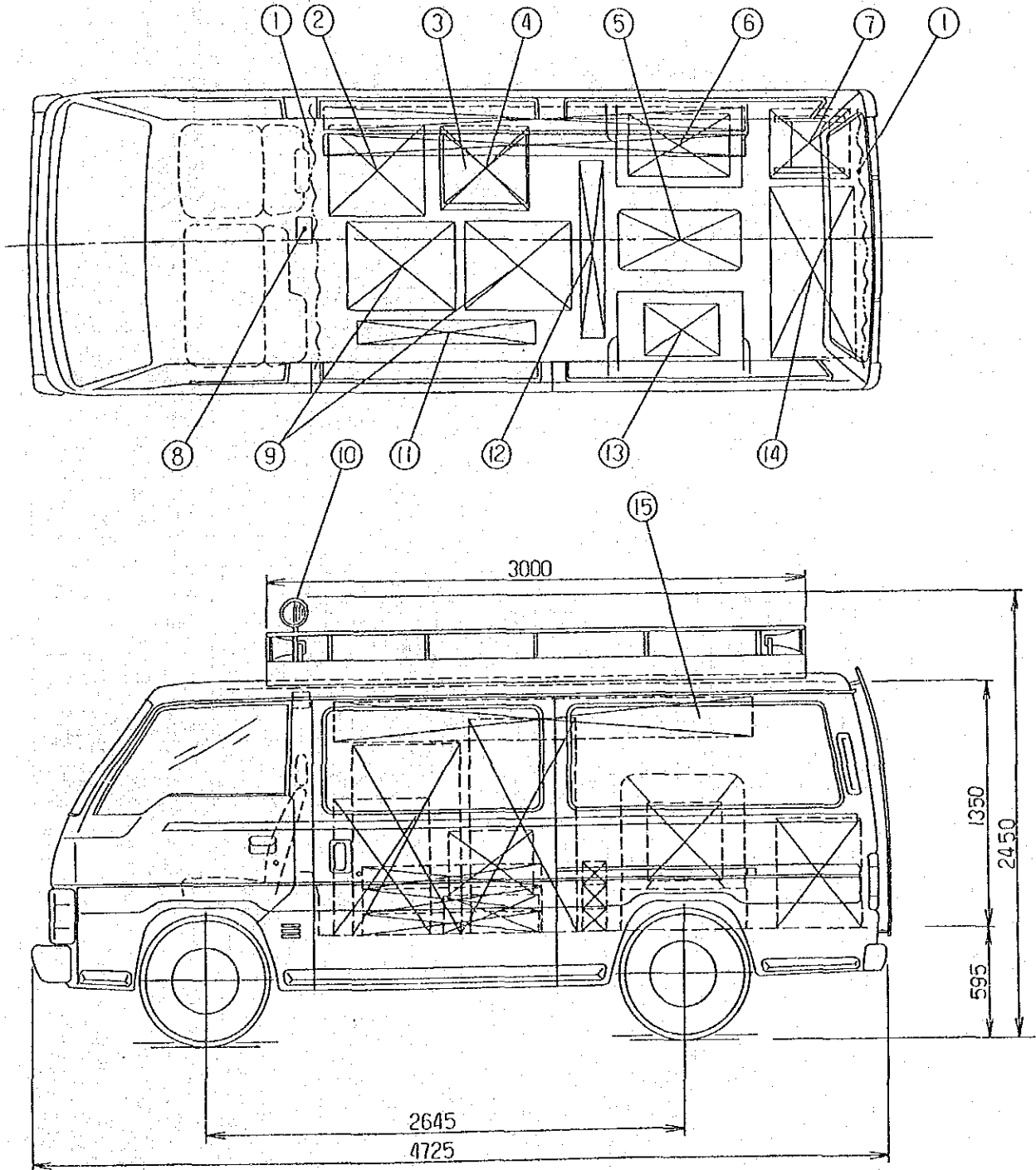

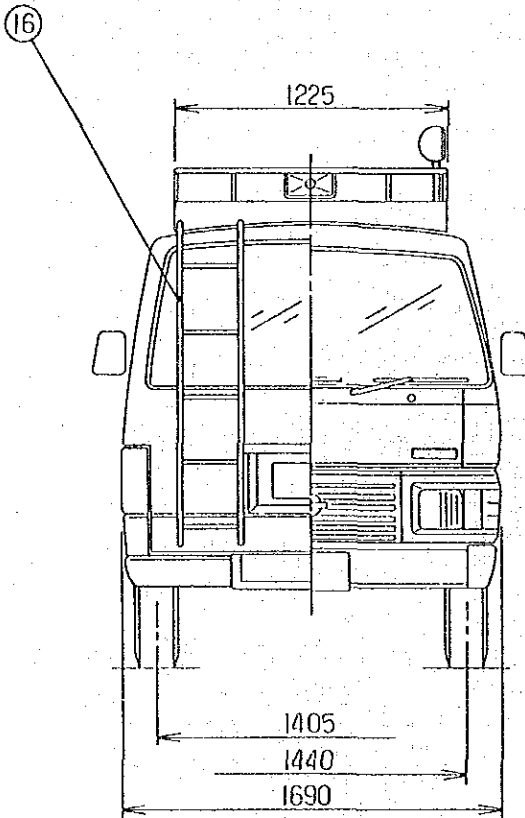
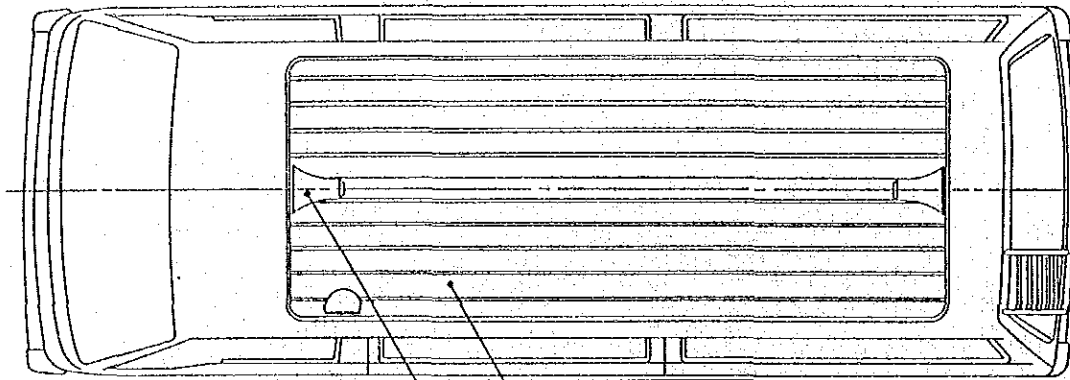

18	ROOF DECK	1	1225 x 3000
17	ROOF SPEAKER	2	
16	LADDER	1	
15	FLAT SCREEN	2	
14	ENGINE GENERATOR	1	50HZ 5KVA
13	16MM FILM SOUND PROJECTOR	1	
12	MICROPHONE STAND	2	
11	SPEAKER STAND	4	
10	ROOF LAMP	1	55W
9	PROJECTOR WAGON	2	S.M. SIZE
8	MIXER & POWER AMPLIFIER	1	
7	CABLE REEL	1	
6	35MM SLIDE PROJECTOR	1	
5	COLOR VIDEO PROJECTOR	1	
4	VIDEO TAPE RECORDER	1	
3	COLOR VIDEO MONITOR	1	
2	SPEAKER SYSTEM	1	POWR ANP = 1 SPEAKER = 4
1	CURTAIN	2	
NO,	DESCRIPTION	QTY	REMARKS

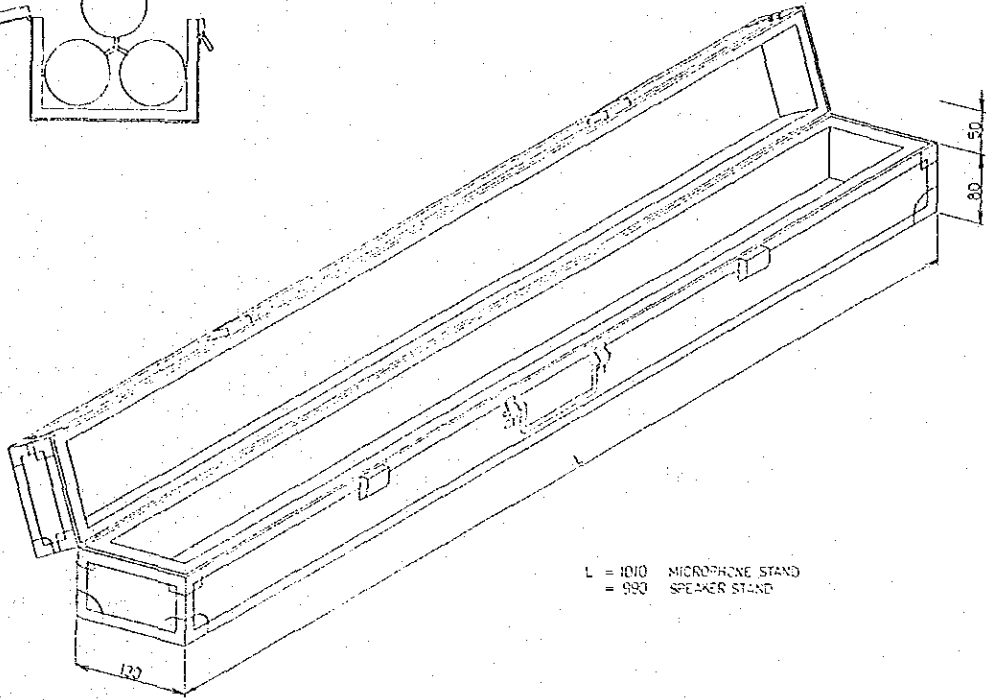
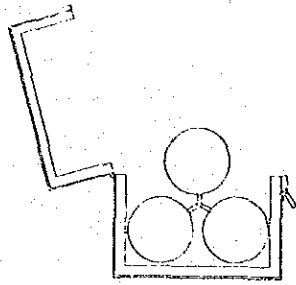

L = 1010 MICROPHONE STAND
 = 990 SPEAKER STAND

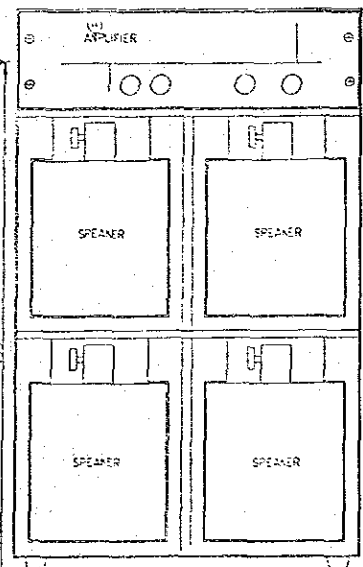
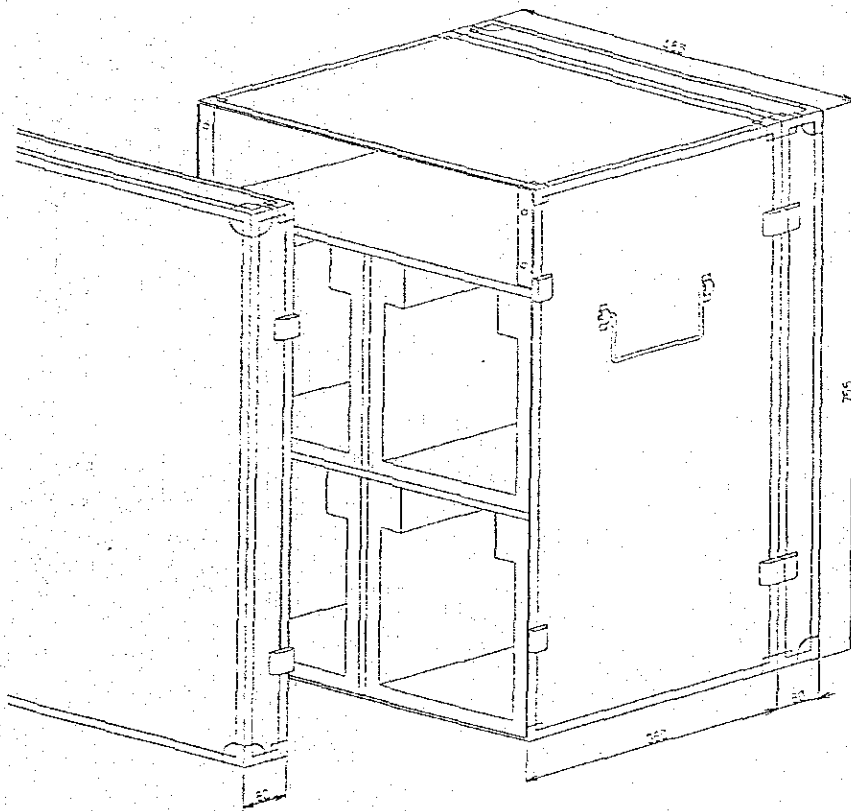

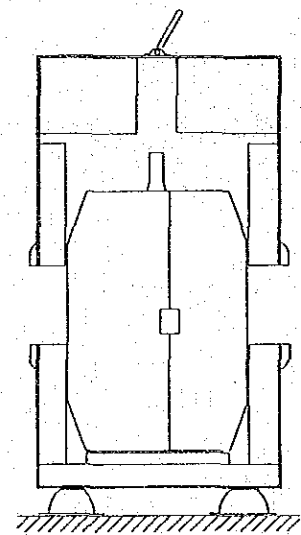
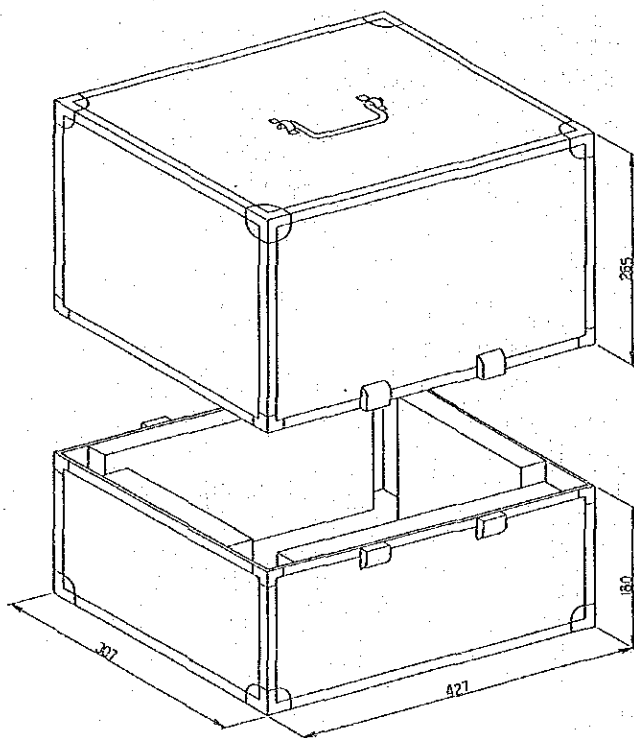
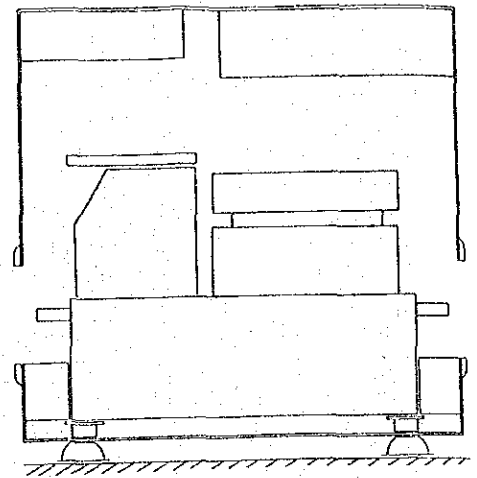
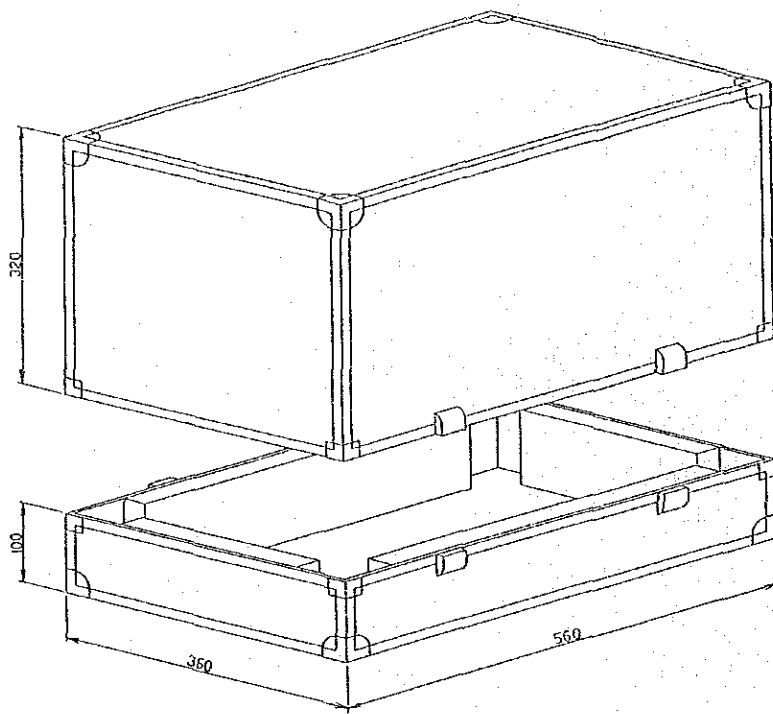

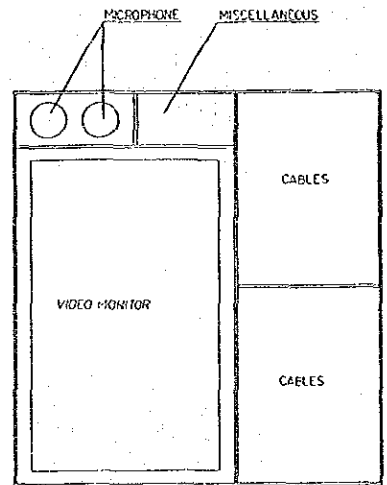
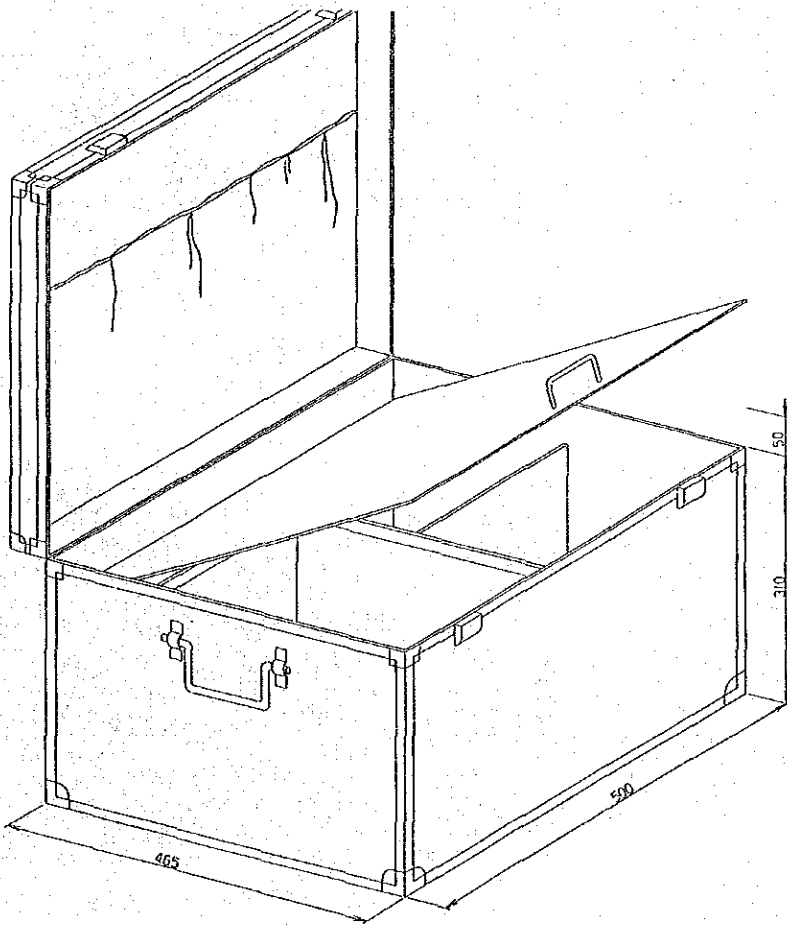
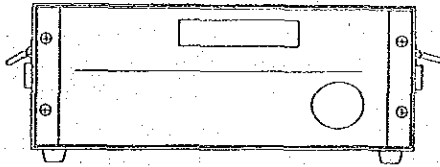
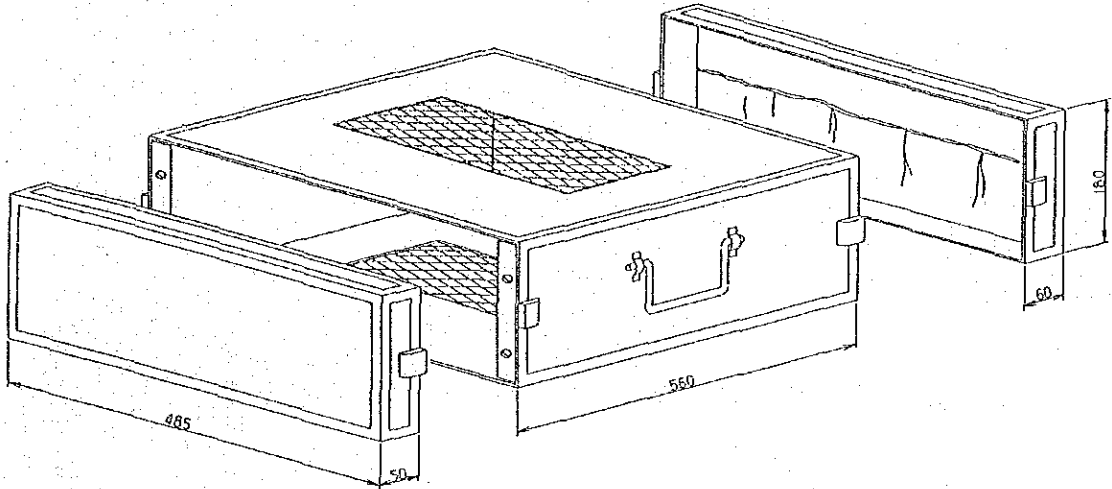

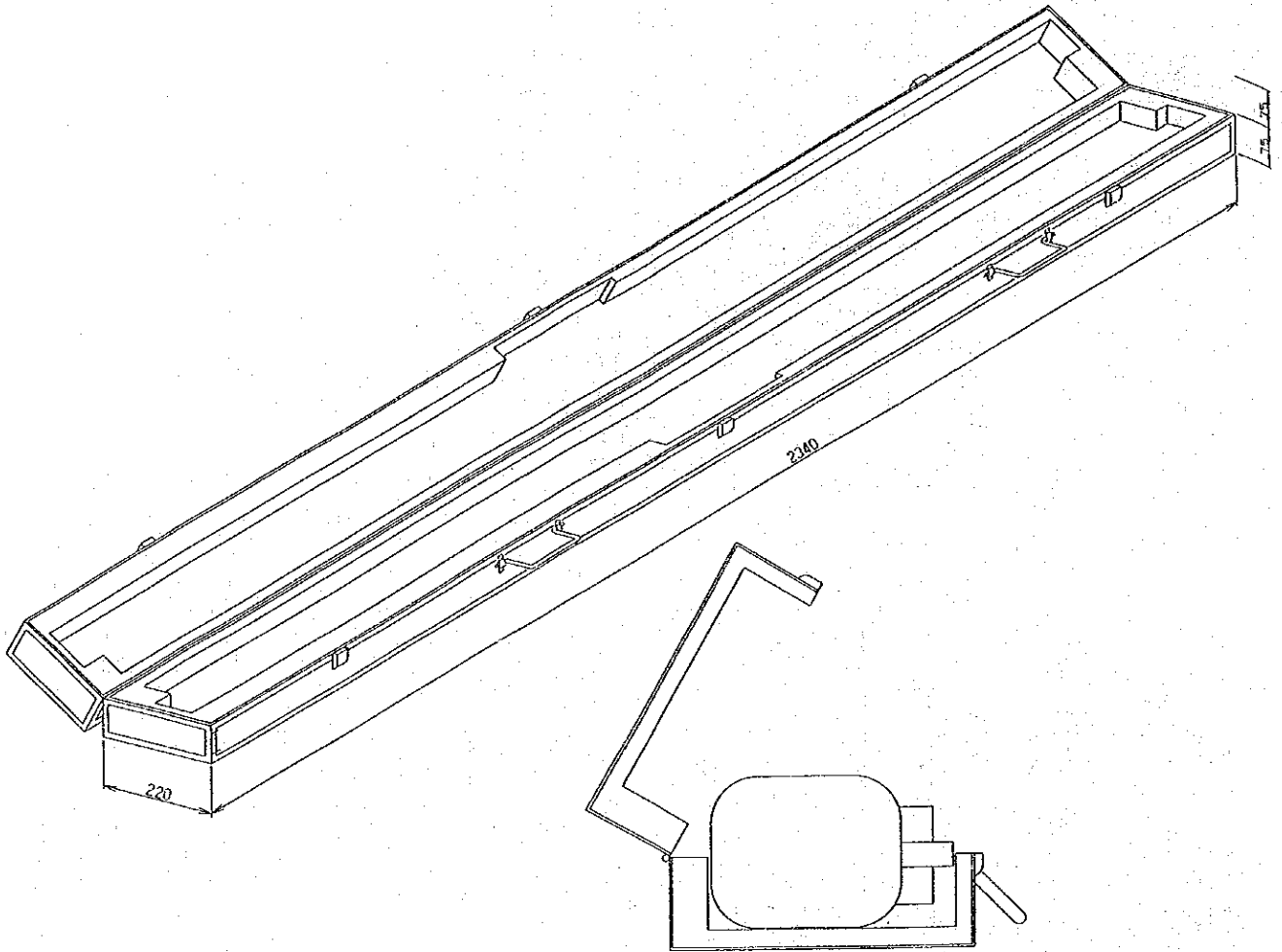

EC 車



照明およびスピーカーをルーフデッキに設置（照明は取りはずせる。）



リアウインドー部分にラダー取り付け

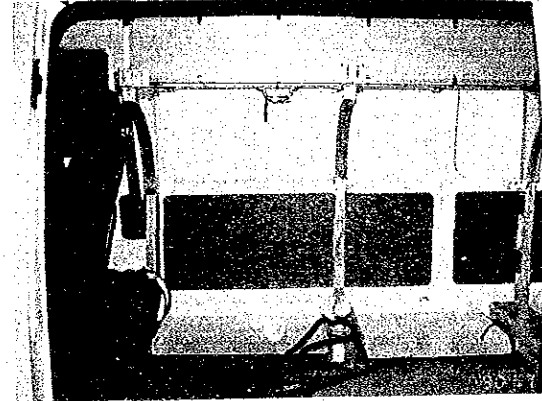

車 内

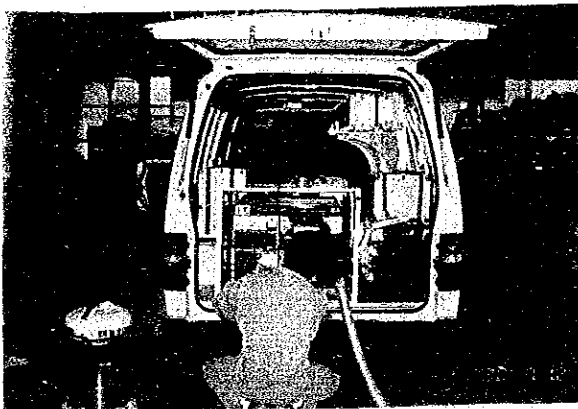

ジェネレーターは車内に固定した。

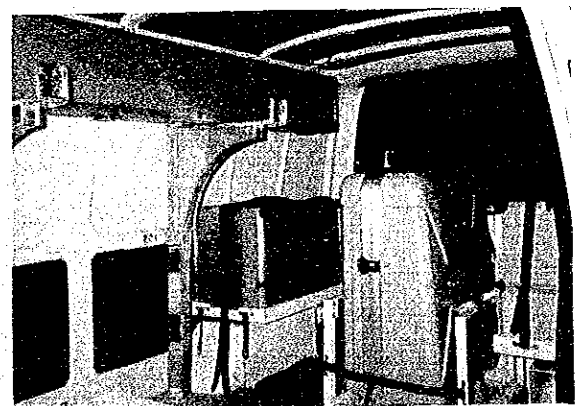

各機材をバンドで固定する。

IE 車の搭載機材

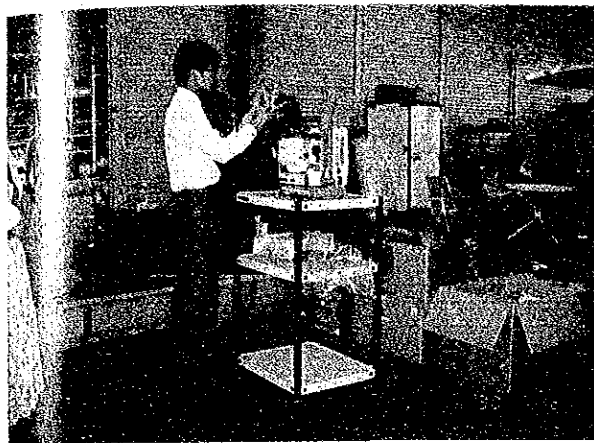

16 mm 映写器



スクリーン

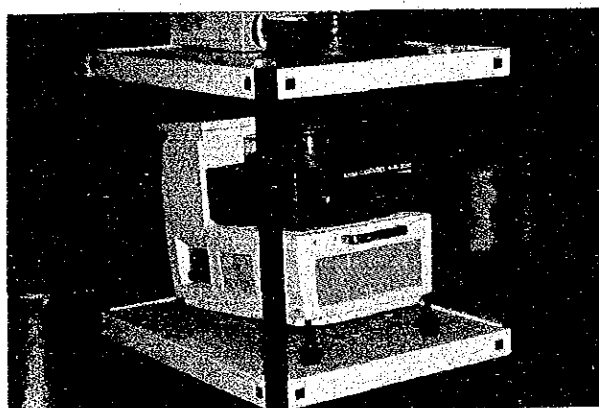

35 mm スライドプロジェクター



ビデオモニター、ビデオプロジェクター
ビデオテープレコーダ



ビデオモニター、ビデオプロジェクター、
ビデオテープレコーダ



REPUBLIC OF KENYA

Population Policy Guidelines

Sessional Paper No. 4 of 1984

OFFICE OF THE VICE-PRESIDENT AND MINISTRY
OF HOME AFFAIRS

National Council For Population and
Development

Population Policy Guidelines

SESSIONAL PAPER No. 4 OF 1984

CONTENTS

1. PREAMBLE
1.1. Summary of Past Activities in Population Matters	1-4	
2. THE ESTABLISHMENT OF THE COUNCIL	4-5	
3. THE POPULATION PROBLEM	5	
3.1. The Past and Current Population Situation	5-7	
3.2. The Social Cultural Factors	7-9	
3.3. Effects of Rapid Population Growth on Social and Economic Development	9	
3.3.1. Population and Land	9	
3.3.2. Increasing Dependency Burden	9-10	
3.3.3. Labour Force Growth	10	
3.3.4. Basic Need Services	10	
3.3.5. Education	10-11	
3.3.6. Health	11	
3.3.7. Housing	11-12	
3.3.8. Food	12-13	
4. PRIORITIES AND STRATEGIES	13	
4.1. Documentation and Evaluation of Population Activities and Agencies	14	
4.2. Research	14-15	
4.3. Population Education	15-16	
4.4. Service Delivery Systems	16	
5. POPULATION POLICY GOALS	16	
5.1. Demographic Goals	17	
5.2. Education Goals	17	
5.3. Clinical Services Goals	17-18	
6. CURRENT AND FUTURE POPULATION ACTIVITIES	18	
6.1. Ministry of Health	18-20	
6.2. Ministry of Finance and Planning	20	
6.3. Kenya Catholic Secretariat	20-21	
6.4. National Christian Council of Kenya	21	
6.5. Protestant Churches Medical Association	21	
6.6. Salvation Army	21-22	
6.7. Family Planning Association of Kenya	22	
6.8. Maendeleo Ya Wanawake Organization	22	

CONTENTS—(Contd.)

6.9. Office of the President	22-23
6.10. Ministry of Education, Science and Technology	23-24
6.11. Ministry of Information and Broadcasting	25
6.12. Ministry of Agriculture and Livestock Development	25
6.13. Ministry of Culture and Social Services	25-26
6.14. Ministry of Labour	26
6.15. Ministry of Co-operative Development	26
6.16. Ministry of Water Development	26-27
6.17. Ministry of Environment and Natural Resources	27
6.18. Ministry of Local Government	27
6.19. Ministry of Lands and Settlement	27
6.20. Ministry of Works, Housing and Physical Planning	27
6.21. Ministry of Transport and Communications	28
6.22. Ministry of Energy and Regional Development	28
6.23. National Council for Science and Technology	28
6.24. Office of the Attorney-General	28
6.25. University of Nairobi, Moi University and Kenyatta University College	28-29
6.26. Other Religious Denominations	29
6.27. Other Organizations	29
6.28. Research, Evaluation, Documentation and Information Dissemination	29-30
6.29. Kenya African National Union	30
7. POPULATION POLICY GUIDELINES—AREA OF FOCUS	30
7.1. The Role of Leaders	30-31
7.2. The Role of Education	31
7.3. The Clinic Services	31-32
7.4. The Role of Mass Media	33
7.5. Institutional Framework	33
APPENDICES	34-39

NATIONAL COUNCIL FOR POPULATION AND POPULATION POLICY GUIDELINES

DEVELOPMENT

1. Preamble:

Kenya's 4th Development Plan (1979-1983) states under the Population Policy (p. 61 para 2.156) that: "In Kenya decisions on family size rest with parents. These decisions taken together determine the rate of population growth in the nation. While the Government is concerned about the rapid rate of population growth in Kenya, it is also convinced that as these concerns come to be understood in terms of effects on family welfare and quality of life, parents will adjust their decisions in favour of smaller families". The current Development Plan 1984-1988 states further: "Since the rate of population growth is mainly determined by decisions taken by parents on family size, during this Plan period the Government, in co-operation with Non-Government Organizations, will intensify its programme of informing and educating actual and potential parents regarding the benefits of smaller family sizes particularly since the fertility of less educated women is found to be higher. Family planning services will be made available mainly in the rural areas, by increasing the number of health facilities offering family planning services and also the number of trained personnel to provide these services".

Before the above policy statements were formulated, many activities had taken place in the field of population awareness which culminated in the creation of the National Council for Population and Development (NCPD) in 1982. It is important to understand the background to the population issues in Kenya—at least since independence. The following summary is relevant.

1. *Summary of Past Activities in Population Matters*.—The concern of the Government of Kenya as regards the high

population growth rate goes back to 1962, when the census revealed a population size of 8.6 million persons and an inter-censal growth rate of 3.3 per cent per year. In early 1960s, a group of private Kenyan individuals had started Family Planning Association of Kenya to help those Kenyans who needed the FP service. The Sessional Paper Number 10 of 1965 titled *African Socialism and its Application to Planning in Kenya* which was a Government statement on Kenya's National Goals and her philosophy of development, gave an overall strategy for development. The general theme running through the paper was: the need to plan and control the use of resources for optimum benefit to all Kenyans. The concern about the rate of population growth and its impact on resources and the rate of development was noted.

The concern about the high rate of population growth and its effect on economic development prompted the Kenya Government in 1966 to invite a Population Council Advisory Mission to study the situation and make recommendations. Partly prompted by the Mission's report, the National Family Planning Programme was officially begun in 1967. Family planning was integrated with maternal child health, and the Ministry of Health was given the responsibility for implementing the programme. Acceptance of family planning services were to be wholly voluntary, and individual customs and values family size and the spacing of children.

Due to the lack of an effective health infrastructure and lack of trained personnel in family planning, the Ministry of Health depended on private organizations like International Planned Parenthood Federation (IPPF), Family Planning Association of Kenya (FPAK) and expatriate staff to carry out family planning work.

The 1969 census results confirmed earlier findings about high fertility. On the basis of this information, the Government decided to launch a family planning five-year (1975-1979) programme, which was to serve as the basis for the expansion and integration of services, and to provide operational target

against which to measure achievement. The specific goals of the programme were to help reduce the high annual rate of natural increase of population from 3.3 per cent (in 1975) to 3.0 per cent (in 1979) and to improve the health of both mothers and children under the age of five years. The programme had the following initial responsibilities:

- (a) To establish National Family Welfare Centre with a technical support of four divisions,
- (b) To establish 400 MCH/FP daily-service delivery points and part-time services rendered by 17 mobile teams at some 190 clinics,
- (c) To provide in-service courses for nurses in family planning, and
- (d) To intensify information and education activities through 817 Family Health Field Educators (to be trained).

A related health objective was to recruit 640,000 new family planning acceptors, and thereby to avert some 150,000 births.

The programme made considerable progress in information and education activities. Between 1975-79, the MCH performance was very encouraging. It is estimated that the programme covered about 72 per cent of the pregnant women and 19 per cent of children between ages 0-5 during the plan period. Also by the end of 1979 the MCH programme had built up an infrastructure for effective delivery of the services.

However, the family planning component had limited success. In predicting a decline in the population growth rate from 3.3 per cent (in 1975) to 3.0 per cent (by 1979), the five-year plan had assumed a decline in birth rate from 50 to 47 per thousand and a death rate of 17 per thousand throughout the plan period. Neither of these two assumptions materialized. The 1979 census yielded an estimated crude birth rate of 52 per thousand and a reduction in the crude death rate to about 14 per thousand. Thus, instead of a decline in the population growth rate, a significant increase occurred that raised the rate to about 3.8 per cent in 1979.

In part, these shortfalls can be explained by the assumptions made in setting the targets. It is clear that at the time of the preparation of the Plan the Government's commitment to strengthen Family Planning Programme was overestimated. A second important point is that the Plan concentrated heavily on the supply side of family planning instead of putting greater emphasis on programmes aimed at changing family size norms. Thirdly, the programme relied excessively on the Ministry of Health as the vehicle to achieve its objectives hence an opportunity was lost to tap the resources of other Government agencies and Non-Government Organizations.

It was with the realization of the need to improve on the above mentioned weaknesses that the Government of Kenya approved the establishment of the National Council for Population and Development in 1982. The Council is now expected to co-ordinate the activities of the Government Ministries and Non-Governmental Organizations involved in the Integrated Rural Health/Family Planning Programme.

2. The Establishment of the Council:

Kenya's population is among the fastest growing in the world. Its annual growth rate, currently estimated at 3.8 per cent, places considerable constraints on the social and economic development goals. Some of the effects of this population growth rate have already manifested themselves into social problems such as high and growing dependency burden, unemployment, unplanned parenthood and increasing demand on basic services such as health, education, nutrition and shelter. Over the last two decades, these problems have increasingly become the key concern of the Government.

Despite this concern and the considerable achievements made by the Government in health improvement and the general provision of other basic need services, past efforts have not satisfactorily dealt with problems emanating from a high population growth rate.

In a renewed effort in 1982 the Government established the National Council for Population and Development. The Council was set up to formulate population policies and

strategies, and to co-ordinate population oriented activities aimed at reducing Kenya's population growth rate (see Council's Terms of Reference in Appendix I). This document maps out specific priority areas and recommendations to facilitate the achievement of the Council's goals.

3. The Population Problem:

3.1. *The Past and Current Population Situation.*—The 1979 census indicated that Kenya's population had reached 15.3 million with an annual growth rate of about 3.8 per cent. The earlier censuses had indicated that the population was growing rapidly both in absolute numbers and in annual rate of growth. In 1969, for instance, the population was 10.9 million with an annual growth rate of 3.3 per cent. As can be seen from the table below the economy of Kenya is not growing fast enough to keep up with the rate of the population growth.

REAL RATES OF GNP GROWTH (%)*

	1979	1980	1981	1982	1983	Average
Plan (1979—83) ¹	4.5	7.0	6.5	6.7	6.9	6.3
Revised (1980)	3.5	5.8	5.8	5.9	6.0	5.4
Revised (1982)	4.2	3.0	3.0	4.8	4.8	4.3

Source: Sessional Paper No. 4 of 1982

Development Prospects and Policies—P. 5 Government of Kenya.

The lag between the economic growth and population growth therefore implies that the economy increasingly faces problems accruing to a fast growing population.

Of the three processes by which population changes, fertility and mortality are the most important. Inter-country migration is not an important factor in Kenya's population change, but internal migration is an important factor of regional population changes. The impact of non-African Kenyan population, e.g., Asians and Europeans, is minimal from a demographic point of view, (although their role in the limited

international migration is of some significance especially in the loss of technically trained workforce).

Recent estimates on fertility indicate that the average number of children per woman is about 7.9 as compared to a corresponding figure of 7.6 in 1969, giving an increase of 3.9 per cent between the two periods. Fertility is highest among young women aged between 20 and 34.

Kenya has different marriage laws, i.e. Muslim, Customary, Christian and Hindu. The age of marriage under these different laws and customs differ. However, on the average, Kenya women marry at the age of 18 years but this varies by the standard of education and area of residence. Women with post-primary education tend to marry at the age of 23.5 years, as compared to those with no education who marry at the age of 16.5 years on the average. Women residing in urban areas marry at age 19.2 years on the average, whereas rural women marry at 17.8 years. Twenty per-cent of all married women have a pre-marital birth.

Kenya men marry at older ages than women on the average. It has been shown that about 60 per cent of all first marriages, men are about 10 years older than their wives; about 18 per cent of marriages involve men who are more than 20 years older than their spouses¹. Contraceptive usage among Kenya women is low. It is estimated that only 5.8 per cent of women are currently using modern contraceptives. An additional 5 per cent utilize traditional birth spacing methods. The contraceptive use rate among women aged 30 and over is 14 per cent as compared to 4 per cent among women aged under 19 years.

Sixty-eight per cent (68%) of the fecund women indicate they would like to have a child in addition to the ones they have. Seventeen per cent (17%) indicate they do not want another child and the rest are undecided. It is only among women who have already had 9 or more children where the percentage of women who do not expect another birth exceeds the proportion of those who want an additional child.¹

¹Kenya Fertility Survey Vol. 1977/78 page 107.

¹See Kenya Fertility Survey 1977/78 Vol. 1, page 72 for data on women and page 75 for data on men.

Decline in mortality has been one of the major factors responsible for the current high rate of population growth. The estimated crude death rate (CDR) at 14 per 1,000 in 1979 shows a considerable decline from the 1948 figure of 25 per 1,000 population. This decline has resulted in a rise of life expectancy at birth from a figure of 35 years in 1948 to 55 years in 1979. Despite the past declines, mortality levels are still high relative to targeted levels. With improvement in health and the rise in the standards of living, mortality is expected to decline further.

Although migration is not an important determinant of the national population, it is an important determinant of internal population movements, i.e. rural-urban and rural-rural migration. As a result of natural increase and the influence the migrants from rural to urban areas, the urban population increased from about 1.1 million in 1969 to 2.2 million people in 1979. This gives an annual urban population growth rate of about 7.2 per cent.

The evidence represented by the demographic facts discussed in this section, indicate that the major population component that will determine Kenya's population growth rate in future is fertility. Future efforts to lower population growth rate will centre on fertility.

3.2. *The Social Cultural Factors*.—Traditionally, the family was the main reproductive, economic and socialization unit. Within the African context, these functions were founded on a wider kinship social network beyond the immediate family. The family and the community socialized on the values, morals and customs, that formed the basis for their continued functioning as a society. The family also instituted a division of labour based on gender roles. Children were trained to take on specific roles and responsibilities that ensured procreation and survival of society. Procreation and survival were ensured through the institution of marriage, both polygamous and monogamous. Marriage was geared towards achievement of large family sizes, necessary for meeting economic, social and psychological needs of the family.

On the whole, there were several factors which led to small families per woman, for example, high mortality rates among infants and children. In order to ensure proper spacing and child survival, many African societies were practising abstinence from intercourse, prolonged breast feeding and sending the wife away from her husband until the child was at least 3 to 4 years. For non-married, pre-marital sexual intercourse was almost always prohibited.

In order to socialize both men and women into marriage, procreation and other adult roles, individual achievement through rites of passage was emphasized. Men graduated through age groups from herdsboys to community elders while women received parental coaching on motherhood and household roles from both their immediate family and society. As a consequence, high ages at marriages were achieved by both sexes; women also achieved high age at first birth.

As a result of social and economic changes the socializing role of the immediate family and the community has been weakened by the encroachment of institutions such as schools, churches, media and factors such as urbanization, migration and pre-marital births.

Large families were preferred to small families. Preferences for male offsprings tended to reinforce the large family norm since families continued procreation so long as a male child was not delivered. A strong preference for sons was largely due to inheritance rights and carrying on the family name. Women were generally seen as marrying off to other families and excluded from inheritance and eventually severing rights of ownership of resources of their family of origin. However, women were valued as a bride price for their male siblings and as a link in extending family ties through marriages.

Through socialization, family life education was taught to children and young people by both parents and grandparents, peers and society. This centred on awareness about physical changes occurring during individual's growth to maturity, parenthood roles, and responsibility to society.

In modern times, the family continues to be the salient institution for the socialization of the young. However, new institutions such as the school, the church, and the mass media have taken over most of the traditional roles of the family and introduced new values and patterns of behaviour to present-day societies. In view of the wide range of population related problems being experienced by both the youth and adults, strengthening some of the traditional value systems and modifying formal and non-formal educational institutions to address socialization problems occurring at both the family and societal levels is of major importance.

3.3. Effects of Rapid Population Growth on Social and Economic Development.—Four major areas characterize the effects of high rates of population growth at the national level; increasing pressure on land high dependency burden; rapid labour force growth and rising demand for basic services.

3.3.1. Population and land.—Kenya's land space is 582,646 square kilometres of which only 17.5 per cent is cultivable at the moment. The national population density in 1979 was 27 people per square kilometre. The arable land density at 87 persons per square kilometre, rose to corresponding figures of 110 and 154 in 1969 and 1979, respectively. These figures indicate excessive and increasing pressure on land, manifested in farm fragmentation, land degradation through soil erosion and unplanned settlement in marginal lands, which has contributed to a slower growth of agricultural output.

3.3.2. Increasing Dependency Burden.—Kenya's economically active population (i.e. those age 15-59) number 7.2 million, out of a national population of 15.3 million people in 1979. This leaves the rest as the dependent population, (i.e. those aged under 15 and over 60 years). As a result, there are 113 dependants for every 100 economically active people. This ratio could be much higher since the economically active population is not all gainfully employed. With rising population growth rates, the implication is that a large share of individual household and

public resources must increasingly be devoted to the needs of the dependants and hence retard gains in standards of living at the family and national levels.

3.3.3. Labour Force Growth.—One of the consequences of a high population growth has been an increase in the working age population. The labour force consisting of 85 per cent of the population aged 15 to 59 years is estimated to have risen from 3.3 million in 1960 to 6.1 million workers in 1979. This labour force is estimated to reach 7.5 million by 1984 and to 8.9 million by 1988, under the current population growth rate. In 1979 the modern economy could only absorb 15.9 per cent of the total labour force.¹ The rest of the labour force found employment in traditional agricultural and informal sectors, 4 million people who were employed in the informal sectors could be classified as "absolutely poor". In the last decade, Kenya's Gross Domestic Product grew at a rate of 6.5 per cent per annum, and continued to grow at a rate of 4.5 per cent in the eighties. Under the current rates of population growth the Gross Domestic Product could be expected to grow at slower pace, thus reducing further the labour absorptive capacity of the economy which would result in an even greater unemployment.

3.3.4. Basic Need Services.—The rapid rate of population growth has led to an increased demand for the provision of basic need services, particularly education, health, food and housing.

3.3.5. Education.—Currently, education consumes about 30 per cent of the national budget, of which 65 per cent goes to the provision of basic education. Due to the rapid increase of the school age population, the demand for basic education services has risen. In 1981, it had, for example been expected that the school age population would not exceed 3.5 million but it exceeded the 4.1 million mark, a figure that is expected to rise to 4.3

Source: Calculated from the employment data obtained from Statistical Digest, Vol. XXI—No. 3., supplement, and 1979 census.

million in 1984, and reach 5.5 million in 1988. Demand for higher education and training has also increased beyond the nation's educational institutions' capacity. This has led to high attrition rates without creating suitable alternatives to redress the problem.

3.3.6. Health.—The Government supports about 1,182 health institutions and runs about 555 family planning service delivery points. The church missions support 379 health facilities, with 44 family planning service delivery points, and private enterprises (excluding private medical practitioners) support 132 health facilities with very few family planning service delivery points.¹

Despite considerable improvement in both the provision and delivery of health services, further improvements are constrained by a high rate of population growth. The health provision and delivery system is still characterized by a shortage of both medical personnel and service delivery points, disparities in the service provision and financial limitations. At the present time, the doctor-population ratio is one doctor for about 10,000 people, and one nurse for every 2,500 people. A continued rise in population growth rate, would mean the ratio could either rise or fall due to availability or unavailability of resources necessary to provide adequate trained medical personnel and services.

A continued high rate of population growth could also entail deterioration in current health services leading to limitations in expansion.

3.3.7. Housing.—The rapid rate of population growth at the national level has resulted in an equally rapid urban population expansion mainly from rural-urban migration. The current annual rate of growth of the urban population (7.2 per cent) has led to constraints in the provision of housing and the development of unplanned settlements.

If the present rate of urban population growth continues, the demand for housing and other services will exceed the ability of the local authorities to cope with the problem. It will also entail deterioration in maintenance of both the current services and the environment.

There is also a need to improve housing and environmental sanitation in the rural areas especially in squatter schemes, in irrigation schemes, in rural market centres, and in unplanned settlements in marginal lands.

3.3.8. Food.—Kenya's "food policy" hinges on two general objectives; first, the production of sufficient food to ensure provision of adequate nutrition for her population, and secondly, to produce enough food surplus to guarantee some food export to earn foreign exchange, and at the same time supplement family incomes at the household level.

The above objectives have been formulated as a result of escalating nutrition related problems such as lack of protein among infants and children and acute nutritional deficiencies, especially in the semi-arid areas of the country, among the low income families in both the rural and urban areas; and in large farm areas which are heavily cash-cropped, at the expense of food crops.

Part of the reasoning behind the food-related problems is the high rate of population growth that continues to frustrate efficient production of food and the government effort to sufficiently meet the nation's food requirements, including food distribution in the country.¹

There are close similarities between population related problems at the national level and those that are experienced by families at the household level. At the national level the concern is to meet the basic resource needs of the population, while at the household level, the concern is to meet the basic needs of the family members; these

¹Kenya Gazette Notice No. 3211 "Health Institutions in Kenya" of October 29, 1982.

two differ only in magnitude. At the household level, pressure on the available resources has mounted during the last decade.

Current and projected population growth rates for Kenya are likely to intensify the burden at both the national and the household levels. Since both the national and the household have to continue providing basic needs for the respective members, national policies to address high population growth rates at the national level should have parallel decisions at the household level to adopt small family norms and consequently small families. This pressure at the family level has manifested itself in the following problem. Increasing difficulty in meeting day-to-day basic household needs such as provision of adequate diet, health and education. This is a problem expected to be acute in large than in small family households.

Deterioration in the health of the mothers resulting from close birth intervals is another concern. This ultimately leads to low economic productivity and diminished attention for siblings. The problem of unplanned parenthood where young mothers after conception and delivery are unable to provide for themselves and their children, and increasingly become dependent on already overstretched family resources. The teenage parents, who are on the increase, generally lack parental and other skills including those which they can utilize in remunerative jobs, that can allow them to set up and maintain independent households.

The problems of inheritance are increasing among some families due to claims by large numbers of siblings on land and other fixed family resources.

4. Priorities and Strategies:

An urgent need has been recognized to provide all relevant audiences in Kenya with information about what rapid population growth implies for the welfare of individuals, families

and the opinion in which family planning can be freely discussed, freely practised without adverse social pressure and fully supported through the provision of relevant services and education. Many agencies have been trying to motivate the public to accept family planning albeit in an unco-ordinated manner.

In recognition of the need for sustained information and education in support of family planning and other population activities in the country the National Council for Population and Development has been created to act as an umbrella organization in supporting, co-ordinating and strengthening the IEC programmes and activities of the participating agencies. To achieve the objectives the Council will adopt several strategies detailed below:

4.1. *Documentation and Evaluation of Population Activities and Agencies.*—Currently, there are several Ministries, Non-Governmental Organizations (NGOs) and individuals carrying out research and programmes in population and related activities. The activities of these agencies and programmes have not been pooled into a document from which the assumptions and policies under which they operate can be discussed. In order to plan future activities in the area of population and national development and integrate the various agencies into programmes aimed at addressing population problems, the evaluation and documentation of existing policy and project activities is a necessity.

In addition to the evaluation of existing agency policies and programmes, it is necessary to have an assessment of government Ministries and NGOs capacity and capabilities to take on added responsibilities through assignments from NCPD.

4.2. *Research.*—Research helps development. In the context of population matters results of social and demographic research would assist the functions of the NCPD. The following are the research priorities considered necessary with a view to finding out:—

(i) Adolescents fertility,

(ii) The relationship between the status of women, their participation in the labour force and how this affects fertility,

(iii) The cost and the value of children to various groups of parents,

(iv) The influence of household decision-making process on reproductive goals,

(v) The impact of labour migration from rural areas on fertility and its impact on resources,

(vi) The effect of specific government policies (e.g. on land adjudication) on the household fertility decisions,

(vii) The influence of specific institutions (e.g. religion and education) on fertility,

(viii) The factors and problems related to the use and non-use of all forms of contraceptives,

(ix) The extent and problems related to infertility, and sub-fertility, and

(x) The extent of abortion and its consequences in health and in social-psychological areas.

4.3. *Population Education*.—Population education, as an area of study, is relatively new in population studies. Population education, however has been acclaimed as an educational response to population and other related problems. As such this type of education can be introduced as family life education, sex education, family planning, birth control, etc. to various groups while aiming at the consequences of the rapid growth of population to the development. Education has been found to be an important factor in matters of family formation and other population processes. It is accepted that learning takes place from as early as infancy and continues

throughout the life cycle. Thus, there is need to explore what is learned at different stages of an individual's life.

Family size orientation of young people, for example, is an outcome of their learning from the family, peers, the school, the church, the mass media, in addition to other sources through which learning takes place. There is need, therefore, for research to find out "when" and "what" kinds of information the young people get from the various teaching agents, and ways in which these agents could be utilized to bring about the desired population changes. It is thought that various population education concepts could be introduced in various subjects such as mathematics, religion, civics, geography, home economics, etc. and teachers could be trained in how to teach the population subject at various levels.

4.4. *Service Delivery System*.—Currently, family planning services are being delivered through government health institutions, private hospitals, Family Planning Association's Clinics, private medical practitioners and some church-related health institutions. Given the limited number of service delivery points and the number of people qualified to provide contraceptive services including counselling and following-up exercises, there is a likely danger of over motivation of few family planning clients without ensuring the ease of availability of the services.

In view of this, it is recommended that priority be given to the whole area of provision of quality services through all possible outlets in the country. Community based distribution of contraceptives is a new method which should be encouraged and training and supervision of the distributors be carried out by the Ministry of Health in collaboration with other service-providing agencies.

5. Population Policy Goals:

In view of the problems reviewed above, the following goals to guide policy and programme planning are suggested:—

5.1. Demographic Goals:

- (i) To reduce population growth rate from the current 3.8 per cent to 3.3 per cent by 1988 (see Appendix 2),
- (ii) To encourage Kenyans to have a small family,
- (iii) To reduce fertility level, that sustains the high rate of population growth and at the same time assist those couples, as well as individuals who desire but are unable to have children,
- (iv) To reduce mortality further particularly the infant and child mortality, because such reductions would ultimately lead to lowering the fertility,
- (v) To reduce rural-urban and rural-to-rural migration which help to create the unplanned settlements in marginal lands and to help ease the pressure on basic need services in both the rural and urban areas,
- (vi) To motivate Kenya males to adopt and practice family planning.

5.2. Education Goals:

- (i) To improve the status of women through equal access and opportunities in higher education, training and remunerative employment,
- (ii) To improve general education attainment levels for both males and females and enhance the educational institutions capacity to provide relevant skills for the youth, and
- (iii) To provide the youth with information and education concerning population matters.

5.3. Clinical Services Goals:

- (i) To ensure availability of contraceptives services for those women and men who are ready for and need them,
- (ii) To ensure adequate counselling, examination and a follow-up of the contraceptive users,

- (iii) To train, retrain and supervise health and other contraceptive workers in provision of contraceptive services, and
- (iv) To be vigilant about the type and quality of contraceptives being provided in the service delivery points.

6. Current and Future Population Activities:

As stated earlier, several agencies have been involved in population and family planning activities for several years. The Council will strengthen such activities. As a first step, the Council has approved funds for 15 projects which are being implemented by six NGOs and two Government Ministries. A summary of these projects to be undertaken by each of the agencies and future activities are as follows:

6.1. Ministry of Health

The Council has approved funds for the following activities to be undertaken by this Ministry:

- (a) Production and distribution of a newsletter aimed at motivating Ministry's staff and others,
- (b) Production of mass media materials aimed at giving details of local family planning services,
- (c) Strengthening family planning clinics and providing extensive education through production of core materials e.g., flip charts, posters and workshops, specifically for the Ministry's staff, and
- (d) Mass media support for family planning inter-personal communication through local campaigns to publicize opening of new services delivery points and dispel misconceptions on family planning.

In addition, the Divisions of Health Education Unit, the Integrated Rural Health Project, the Administration Support Unit and the National Family Welfare Centre should play a central role in carrying out the following recommendation:

- (i) *Training.*—Population education should be integrated into the existing curriculum, at all levels of training of medical and paramedical personnel.

(ii) *Maternal Child Health and Family Planning (MCH/FP).*—The Ministry has plans to strengthen the programme aimed at improving the health of the mother and the child by establishing more rural health facilities and expanding the training of health personnel. The aim should be to ensure that such services are available to those who need them.

(iii) *Research and Evaluation.*—The Ministry hopes to undertake a drop-out study of family planning acceptors of MCH/FP. In addition the Ministry would evaluate its on-going activities particularly those related to family planning e.g., the impact of training of Family Planning Field Educators (FPFEs), low contraceptive adoption problem and service delivery programmes. Another important area of research should be to strengthen the Ministry's capability to collect data on births and deaths in order to give it the ability to relate provision of health and related services to mortality and fertility.

(iv) *Production of Educational Materials.*—The Health Education Division is currently involved in production of health educational materials in addition to organizing seminars. Such materials would be reoriented to include specific population messages emphasizing the relationship between health and other related components to population factors. In the production of population related materials, the Division would liaise with the relevant participating agencies in educational material production services. The Unit would also strengthen community based dissemination of the population related information.

(v) *Provision of Information and Family Planning Services.*—The Ministry would expand its ability to incorporate population related information at all the service delivery points, mobile units and the primary health care projects to cater for more adolescent and men. The Ministry would also encourage and supervise the community based distribution of contraceptives, including the training of the distributors.

Since there will be several service delivery points both public and private, the Council recommends that a uniform charge for contraceptives be established.

The Ministry should examine possibilities and implication of getting the required contraceptives duty-free in order to enhance easy access to both the users and the implementing agencies.

6.2. *Ministry of Finance and Planning.*—The Council has approved funds for the establishment of a documentation centre within Rural Services Co-ordination and Training Unit (RSCTU) in the Ministry. This centre will be responsible for the collection, processing, storage and dissemination of information to various participating agencies. In collecting and disseminating the information, RSCTU should liaise with the Council to ensure that the agencies receive relevant information.

The RSCTU through its field training programme (i.e. Training District Development Teams), should also encourage utilization of population data for effective planning at the district level.

Since the Ministry is responsible for co-ordination and formulation of the national development plans including the relevant national strategies, policies and programmes this will assist other Ministries/Departments in the formulation of development plans that would facilitate the inclusion of population activities in their programmes.

The Central Bureau of Statistics, a Department of the same Ministry co-ordinates all statistical work within the Government. It undertakes the production of Economic Surveys and Reports; National Sample Surveys, Population Census (including inter-censal surveys) and Demographic Statistical Reports. CBS is expected to continue giving the same services.

6.3. *Kenya Catholic Secretariat (KCS).*—The Council has provided funds to enable the Secretariat to promote a

better understanding of the Christian marriage, the dignity of married persons, the natural methods of family planning and the meaning and protection of human life.

In order for this organization to be more effective, the Council thinks that this organization should broaden its view of the population problem, to facilitate the teaching of population education including such topics as sexuality. The Kenya Catholic Secretariat should mobilize their member churches to motivate the public in matters related to the family and society.

6.4. *National Christian Council of Kenya (NCCCK)*.—The Council is funding activities aimed at providing family life education to adults and youth who are in and out of school. To make these activities more effective the National Christian Council of Kenya should organize and expand the contents of their messages to include other population related issues such as relationship between population and development and how this relationship affects their target groups. The NCCCK should mobilize their member churches to assist in the motivation of the public in matters related to the family and society.

6.5. *Protestant Churches Medical Association (PCMA)*.—The Council is funding activities of this organization which aim at providing population education to youth, both in and out of school, to eventually reduce incidences of pregnancies among the youth.

The Council is of the opinion that the organization should broaden the population information through more utilization of their clinics. These clinics should also be utilized more in the provision of family planning services, training and population education.

6.6. *Salvation Army (SA)*.—The Council has approved funds for a project to teach young people the importance of family planning.

The Council recommends that such activities should include a stronger population education component to enable the youth to understand the relationship between population growth and development and the role of the church in ensuring that while the people's lives' are not endangered by the high rate of population growth there are serious consequences to the nation as a whole.

6.7. *Family Planning Association of Kenya (FPAK)*.—The Council is funding five projects to be undertaken by this organization: two staff development projects, material production and distribution, seminar for private medical practitioners and evaluation of the youth programmes.

The Council recommends that the population education component should be broadened to include more information on the relationship between population and development and service delivery points should be utilized as one of the channels for providing such information.

6.8. *Maendeleo ya Wanawake Organization (MYWO)*.—The Council is funding activities by this organization aimed at providing family planning information to Maendeleo ya Wanawake Women groups in the five districts of Eastern Province: Kitui, Machakos, Embu, Meru and Isiolo.

The Council hopes that the members of this organization will be utilized more to reach more rural families with population related messages. This organization should also devise methods of approaching the women problems from a family point of view rather than separate individual. The organization should also play a vital role in male motivation.

6.9. *Office of the President*.—There are several Government Ministries, NGOs and religious bodies which could play key roles in assisting the Council achieve the goals. Some of the agencies are known to have population-related activities although details of such activities are not fully

known. In this context, through the Directorate of Personnel Management (DPM) the Kenya Institute of Administration, should incorporate and co-ordinate the population education with the training activities of personnel from both the Government and other participating agencies.

The Office of the President should encourage the use of the National Youth Service as a motivation medium for population attitude change.

Through the Provincial Administration the District Development Committees at the local level should assist in orienting the local leaders in population issues, and how to incorporate these into their development projects.

6.10. *The Ministry of Education, Science and Technology.*— The traditional socialization functions of the nuclear family has largely shifted to institutions such as the school, the church, the media, etc. In the traditional society the individual, right from the infancy to adulthood, was socialized and trained by the family and the community. The parent's opportunity to socialize the child today is mainly during early infancy and to somewhat reduced duration, during early childhood.

The Ministry of Education, Science and Technology is in charge of pre-primary, primary and all post-primary education including tertiary institutions such as the University and teachers training colleges. As such the Ministry has an important role to play in the education and socialization of Kenya's youth.

The schooling period is a line of growth both physically, socially and psychologically and it is at this stage that the youth needs guidance in all aspects of life. There is no doubt that the Kenya youth should be aware of the importance and problems or implications of rapid population growth in the country. Provided with the information on how population changes and the measures which an individual, the family and the community can take to slow the high rate of population growth, the youth will

no doubt be more aware about population growth and will be inclined to do something about it. In view of this the following points are commended.

- (a) Integration of certain study units of population education in existing courses at all levels of schooling emphasizing population change processes (i.e. fertility, mortality and migration), and the consequences of such changes to the individual, community and the nation; the implications of unplanned parenthood for the families and the youthful parents themselves. The population education should also aim at reinforcing the youths to appreciate a small family and what this means for both national and individual development.
- (b) The teacher training curriculum in particular should incorporate a strong population education section that will enable the teachers to get acquainted with relevant population knowledge and enable them to offer required courses at the various levels of schooling.
- (c) In developing population education content for integration into the existing curricular, deliberate effort should be made to ensure that this is reflected in examinations along with other subjects.
- (d) In order to ensure the consistency of what is taught and learned in schools, parents should be motivated through parent teacher association (PTA) and board of governors to follow-up their children's education and socialization aspects both at home and in school.
- (e) The Ministry should ensure that all other institutions (e.g. Polytechnics, Institutes of Science and Technology, Technical Colleges and other training institutions, University, etc.) undertake to incorporate population education in their syllabi.
- (f) It is recommended that Kenya National Union of Teachers use its structures and facilities and opportunities to infuse population education among

teachers. The organization should also run in-service courses and seminars to teachers dealing specifically on population matters.

6.11. *Ministry of Information and Broadcasting.*—This Ministry should make people aware of the population programmes and other activities as well as related problems by putting captions at strategic times to highlight the NCPD activities, produce and/or serialize programmes on population and related activities through discussions, conferences, interviews and plays/acts. The print media and other media forms would also be useful.

The Ministry should broadcast population related activities for both out-of-school youth and adults in both national and vernacular languages.

6.12. *Ministry of Agriculture and Livestock Development.*—The Ministry, through its extension workers and training programmes, should infuse population education activities in the activities of extension workers and the curriculum of training programmes in order to equip extension and other personnel with population education and relevant skills sufficient to enable them to relate population problems to rural development activities.

6.13. *Ministry of Culture and Social Services.*—Certain Departments of this Ministry should help NCPD in various ways. For instance, the Family Life and Community Development programmes should integrate and develop population programmes oriented to men and women. The Department of Community Development in particular could be of great assistance to NCPD in following up the Community affairs at the locational and divisional levels where Community Development Assistants (CDA) could be used as one of the agents for Community Based Distribution of Contraceptives (CBDC). The Department of Adult Education should be encouraged to include population and family planning topics in their literacy programmes. The Department of Youth should be encouraged to include in their training

information concerning population and development and should urge youth to discuss the issue of population as is related to them and the environment.

The Cultural Division, through drama and dances, should be encouraged to stage plays concerning the family, the youth, the aged, etc. and drawing the relevant material from the traditions existing in society. These material for drama and plays should also reflect the reality as it is today.

6.14. *Ministry of Labour.*—The Ministry should orient its own staff on the relationship between labour and rapid population growth, and at the same time aim at creating awareness among workers on the same problem, as well as introducing population education and family health services. The Ministry should strengthen its programmes of training by including population and family life education for its staff and trainees. In addition, the Ministry of Labour, through its occupational health services at the plant or industry level, should include information on provision of family planning services. This Ministry should get to the workers through the Central Organization of Trade Unions which should rally its membership to introduce population and family life education into programmes targeted at workers education.

6.15. *Ministry of Co-operative Development.*—This Ministry has a co-operative education division as well as a mandate to co-ordinate and oversee the functioning of co-operatives in the rural sector. Under its training umbrella, it should modify the co-operative curriculum to acquaint its workers with population issues and how it is related to rural development problems to which the co-operative movements are directed. The content should be sufficiently developed to enable the co-operative office personnel to include population information into the working framework of the various co-operatives, and to help the members realize how benefits accruing into participation in co-operative are related to the size of their families and community.

6.16. *Ministry of Water Development.*—This Ministry can demonstrate through population education programmes the relationship between the deficiency of resources such as fuel wood, water and the rapidly growing population. The Ministry should also develop programmes to demonstrate the relationship between clean water and population increase, using the water projects in rural areas.

6.17. *Ministry of Environment and Natural Resources.*—The Ministry should take initiative to establish programmes to educate people about environmental deterioration and depletion of natural resources (e.g. forest resources), as a direct result of excessive population settling in marginal areas. Population and environmental education should be developed and taught in all training programmes.

6.18. *Ministry of Local Government.*—This Ministry should concentrate its efforts to the urban, local and county council's population activities within the existing social work, health and community development by utilizing the existing administrative set-up.

6.19. *Ministry of Lands and Settlement.*—In the settlement programmes, the Ministry of Lands and Settlement should devise ways of incorporating population oriented activities in all their training programmes. The activities of the Ministry in relation to settlement programmes should include an assessment of the effects of these settlements on population growth, migration and the impact of the newly settled population on the environment.

6.20. *Ministry of Works, Housing and Physical Planning.*—The activities of this Ministry should be confined to the urban areas. It should aim at developing programmes that demonstrate the relationship between population and diminishing capacity for local authorities to meet housing services.

The local councils should take part in developing rural projects that could discourage rural-urban migration, the main population process by which urban population

grows. Through multi-purpose centres in estates, the Ministry should develop population education programmes to reach the tenants.

6.21. *Ministry of Transport and Communications.*—This Ministry can develop programmes aimed at demonstrating to the public the relationship between rapid rates of population increase and the deterioration of commuter services, and rising fatalities on the roads.

6.22. *Ministry of Energy and Regional Development.*—This Ministry should oversee the incorporation of population education programmes into the plans and programmes of the regional development authorities.

6.23. *National Council for Science and Technology.*—This Council should facilitate greater participation of women in the nation's labour force, as a strategy to lower fertility levels by encouraging careers rather than familial goals.

The Council can also support certain medical programmes aimed at alleviating infertility and infant and child mortality.

6.24. *Office of the Attorney-General.*—The NCPD will need information on births, deaths, and marriages from the Office of the Registrar-General. Since laws affect population in a different manner, the Office of the Attorney-General should be consulted by the Council from time to time in order to ensure that there is no conflict between various population policies and the law.

6.25. *University of Nairobi, Moi University and Kenyatta University College.*—The Council recognizes the skills and capabilities existing at both the University of Nairobi, Moi University and Kenyatta University College. The University provides training, research and consultancy services to the Government and NGOs. Under these broad areas; faculties and institutes could submit to the Council suggestions on what role they can play in the implementation of the NCPD programmes. However, the Populations Studies and Research Institute at University of Nairobi is already developing research

and training programmes which anticipate the Council's future needs.

6.26. *Other Religious Denominations*.—There are many faiths of various denominations in Kenya. The Council, should invite them to motivate their followers in the matters related to the family and society. The Council could also consider funding some of their projects which are related to the Council's activities. In addition each church as an entity, should be encouraged to discuss with its congregation matters affecting the family and the community as they are related to the development.

6.27. *Other Organizations*.—There are many other organizations in Kenya which, because of their constant contracts with their members should be invited by the Council to suggest how they could be of assistance to the nation in the important task of educating and informing their members and the public about family planning.

Organizations such as the Kenya Nurses Association, the Kenya Medical Association, the YMCA, YWCA, Boy Scouts, Girl Guides, Red Cross Society, the Agricultural Society of Kenya, Mother's Union, Women's Guild and statutory organizations, such as the Lake Basin Development Authority, Tana and Athi Rivers Development Authority, the National Irrigation Board and many others can be requested to help especially with regard to motivation, education and information in matters related to population and family planning. If they play their role, their contribution to the Council's activities would be great.

6.28. *Research, Evaluation, Documentation and Information Dissemination*.—In future programming, the Council recommends that all relevant Ministries and NGOs should furnish the Council with an inventory of planned programmes and activities. Such information should, as much as possible, conform to the following criteria:

- (i) The content and message in information, education and communication.

- (ii) The extent of coverage and the target groups.

- (iii) How the various projects are monitored and evaluated and the impact of the programmes, and

- (iv) Forward information on the training and production of education and other materials.

The Council should consider the desirability of:

- (i) Centralized training for all field educators from participating agencies in order to ensure message consistency,

- (ii) Centralized training of trainers including material design and production, and

- (iii) In addition to the above, there is also need to design and develop messages and materials at the community levels so as to ensure relevance.

To facilitate the NCPD to utilize the material from the Ministries and NGOs, the NCPD should establish and develop a documentation centre, that will enable the Council to co-ordinate the population related and other activities of the participating agencies.

6.29. *Kenya African National Union (KANU)*.—The Council welcomes the direct involvement of the ruling party, KANU, in providing information and education on population matters as well as supporting the policies and programmes of the Council.

POPULATION POLICY GUIDELINES

7. Area of Focus:

7.1. *The Role of Leaders:*

- (a) The time has come when all leaders in this country should provide effective leadership in all matters of population and family planning with a view to reducing the population growth rate.

(b) The leaders at all levels will be involved in guiding, organizing and integrating the population and development programmes at their respective levels.

(c) The National Council for Population and Development will undertake the training and development of leadership in population and family planning work in order to support the technical services.

(d) The Government machinery for rural development will in future be based on the "District Focus". For this reason, all the leaders at the local level would be involved in population and family planning work through their local development committees. These matters should be integrated with other issues discussed and implemented at the district level.

7.2. *The Role of Education.*—It is now recognized that traditional methods and values have been eroded and that the responsibility of the parents has, to a large extent, been passed on to the teacher, who is expected to teach family life education in the school. Consequently, emphasis will be made on the following:

(a) the school curriculum must be strengthened and should aim at different age groups consistent with their biological development and morality.

(b) the education should be used to shape the attitudes of young people towards population and family life education and the related problems of rapid population growth and adolescent pregnancy which is an emerging serious problem associated with many deaths and suffering.

(c) Moral and ethical teaching of our youth will be intensified. In this connection, there is need for teachers, parents and officials of government and non-governmental agencies to co-operate closely in family life and population education activities.

7.3. *The Clinical Services:*

(a) The traditional methods of family planning are disappearing fast and for the country to achieve significant impact in

slowing down the rate of population growth, this country will have to increasingly rely on modern scientific methods coupled with appropriate knowledge in information and education.

(b) While it is appreciated that the family planning services are expanding, there is need for constant vigilance and improvement in the quality of management, personnel and facilities.

(c) There will be more emphasis on motivation and involvement of men in family planning because the emphasis has been mainly on women in the past.

(d) The provision of comprehensive medical services in all areas as an integral part of development will be improved to ensure survival of children in order to allay parental fears and therefore encourage the adoption of small family sizes.

(e) Certain ethical considerations should be borne in mind by all those who are expected to deal with family planning in Kenya. In particular the following points are relevant.

(i) No individual should be coerced to practise any method of family planning inconsistent with such an individual's moral, philosophical, or religious beliefs.

(ii) Family planning activities should be conducted in a manner that safeguards the rights, health and welfare of all individuals who take part in family planning programmes.

(iii) Induced abortions as a method of family planning is contrary to the wishes of the Government of Kenya. No special fees or incentives of any kind should be used to women to coerce or motivate them to have abortions.

(iv) All forms of surgical sterilization must be voluntary after the clients have been given all the relevant information. A written consent in a language a client understands and speaks must be signed by each client before a surgical contraception is done.

7.4. *The Role of Mass Media.*—The mass media has an important role to play in information and population education and will therefore be used to the maximum in providing population information and mobilizing the community.

7.5. *Institutional Framework:*

- (a) The Government will endeavour to fund the population activities in this country and will involve all the relevant ministries and agencies at all levels.
- (b) The role of NGO's will be strengthened and the necessary financial support will be provided to them with a view to complementing Government in promotion of population/ family planning activities.

APPENDIX I
THE NATIONAL COUNCIL FOR POPULATION
AND DEVELOPMENT
TERMS OF REFERENCE

1. To determine priorities in the fields of family planning and population development activities in Kenya, in relation to the social and economic policies of the Government.
2. To advise the Government on a national population policy including general planning and application of available financial resources.
3. To advise the Government on the scope and direction of all family planning and population development activities in Kenya.
4. To plan, supervise and co-ordinate an inter-agency multi-media information and education programme aimed at spreading family planning knowledge and practice and the improvement of maternal and child health in Kenya.
5. To promote public understanding and acceptance of the concept of family planning and a small family size.
6. To promote research into social, cultural and economic aspects of population planning and development.
7. To receive, evaluate and programme selected proposals and suggestions from the Government, agencies and other organizations, which contribute to the realization of the Council's objectives.
8. To promote research into contraceptive technology and encourage innovative approaches to family planning in Kenya, including the application of natural methods.
9. To liaise with donors and participate in negotiations for the funding of the projects in the programme.
10. To co-ordinate and control the receipt and disbursement of all funds required to finance the Council's activities.
11. To provide technical and other support services to the participating agencies in the carrying out of the programme activities.
12. To advise the Government on the annual budgeting requirements of the Council covering each year's proposed activities.

ESTIMATES OF CONTRACEPTIVE ACCEPTORS AND USERS REQUIRED TO ACHIEVE POPULATION GROWTH RATE

GROWTH RATE

One of the demographic goals of the Council will be to reduce population growth rate from 3.8 per cent per annum in 1984 to 3.3 per cent per annum in 1988. The purpose of this section is to estimate the level of contraceptive use needed to achieve this goal, the number of births to be averted and the contraceptive acceptors needed to avert them.

First the married female population which will be in the reproductive ages (i.e. 15-44 years) in each year of the period and in each age group was projected (see Table 1). This projection used the 1979 census as the base and assumed a continued female mortality decline between 1979 and 1988, so that the expectation of life at birth increases from 55.4 years in 1979 to 59.6 in 1988.

13. To set up a monitoring and evaluation system for all activities in the programme.

14. To liaise with both local and international organizations engaged in population development activities.

15. To co-opt or otherwise hire the services of experts or consultants in various fields to work with or for the Council, Executive Committee or Secretariat in the execution of any particular task.

16. With the approval of the Minister to undertake any other activities likely to assist in the achievement of the Council's objectives and any other functions as requested by the Government.

TABLE 1.—MARRIED FEMALE POPULATION IN THE REPRODUCTIVE AGES (15-44)
1984-1988

Age	1984	1985	1986	1987	1988
15-19	285,162	296,331	307,571	318,874	330,277
20-24	635,231	653,904	671,712	689,637	707,676
25-29	598,434	629,371	660,273	691,127	721,959
30-34	476,852	499,335	521,803	544,244	566,663
35-39	365,276	384,921	403,541	422,130	440,692
40-44	272,243	285,351	298,466	311,582	324,702

The expected number of births during each year of this period were obtained next (see Table 3) using the projected female population and the 1979 age specific marital fertility rates (see Table 2).

To avert births so as to achieve the population growth rate of 3.3 per cent per annum, the number of desired births in each year of the period is obtained first. Since the number of births depend

on fertility, it is necessary to find the fertility level corresponding to the above growth rate. This was obtained by using the stable population model and the assumed mortality level for the females. A crude birth rate of 43.8 per 1,000 for the female population was estimated to correspond to the female population growth rate of 3.4 per cent per annum, which corresponds to a population growth rate of 3.3 per cent since the female population growth rate is higher because of the lower mortality. Assuming a linear decline of the crude birth rate, the desired crude birth rate in each year of the period (1984-1988) was obtained as shown on Table 3. The desired crude birth rate was then utilized to find the number of desired births and hence the number of births which needs to be averted. (see Table 3).

TABLE 2—FEMALE MARITAL FERTILITY RATES

Age	ASMFR*	Proportions Married
15-19	0.661	27.1
20-24	0.477	71.1
25-29	0.440	84.6
30-34	0.360	86.4
35-39	0.309	86.0
40-44	0.127	82.8

* Age Specific Marital Fertility Rate.

TABLE 3—EXPECTED BIRTHS, DESIRED BIRTHS, BIRTHS TO BE AVERTED AND THE FEMALE CRUDE BIRTH RATE TARGET

Year	Expected Births	Desired Births	Births to be Averted	Female Crude Birth Rate
1984	1,089,491	985,196	104,295	51.8
1985	1,135,032	986,447	148,584	49.8
1986	1,180,510	985,800	194,710	47.8
1987	1,225,958	980,465	245,493	45.8
1988	1,316,681	1,003,531	313,150	43.8

The number of acceptors* needed were estimated by assuming the continuation rates estimated for the 1969-1979 period. From these rates and adjusting for contraceptive use wasted due to infertility after birth, the average effective use, per acceptor in each of the age groups was obtained. Applying the fertility rates on the effective use, the births averted by each acceptor were then obtained. In a given year the prevention of births is achieved by on-going users of acceptors of previous years and those in that particular year. Using this fact, the number of acceptors required to achieve the target births prevention was estimated for each year. (see Table 4).

To estimate the number of acceptors by age group and contraceptive methods the 1979 age distribution of acceptors by method were assumed. The number of acceptors of the different methods were obtained by assuming that the proportion of each of the methods accepted in 1979 will be maintained during the period (1984-1988).

TABLE 4—ACCEPTORS BY AGE GROUPS

Age	1984	1985	1986	1987
15-19	23,174	18,495	21,981	25,691
20-24	62,416	85,798	99,337	112,012
25-29	64,306	89,671	104,460	119,812
30-34	48,375	66,700	76,445	84,642
35-39	35,941	49,642	57,174	63,435
40-44	12,719	17,628	20,565	23,274
TOTAL	237,130	327,934	379,961	428,865

TABLE 5—ACCEPTORS BY CONTRACEPTIVE METHODS

Method/Year	Pill	IUD	Injection	Otherst	Total
1984	159,867	44,556	13,569	19,138	237,130
1985	221,132	61,619	18,702	26,480	327,934
1986	256,369	71,369	21,528	30,695	379,961
1987	289,788	80,544	23,924	34,609	428,865

* Women who accept a family planning method.

† Includes methods of family planning such as condoms, sterilization, etc.

The number of users summarized in Table 6 are obtained by accumulating all previous acceptors who are still in the programme. These were calculated by assuming the 1965-1979 continuation rates.

TABLE 6—NUMBER OF USERS BY AGE GROUPS

Age	1984	1985	1986	1987	1988
15-19	7,258	8,873	11,889	14,685	15,479
20-24	40,828	50,307	66,260	70,554	84,931
25-29	63,442	80,028	106,244	131,553	143,562
30-34	60,034	77,481	102,839	128,340	143,604
35-39	45,476	58,481	77,834	97,833	111,196
40-44	21,934	29,751	40,299	51,148	58,486
TOTAL	238,972	304,913	405,360	504,086	557,259

If the population growth rate is reduced to 3.3 per cent per annum in 1988, fertility would be reduced substantially from 7.9 live births to 6.0 live births.

JICA