

付属資料12-15 ATC装置の設備方

① ATC投入区間の設備

ATCの自動投入方式においては、少なくとも本線に関係する入換信号機に対して、その外方に「ATC投入区間」を設ける。当線区では、車両基地から出区する線路の始端の入換信号機の外方一定区間（約130m）をATC投入区間とし、以下のとおり設備する。



注：この区間に車両が進入するとATC信号コードを受信し、ベルが鳴動しATCは自動的に投入される。0, 信号の場合は、ブレーキも動作する。

② ATC解放区間の設備

ATC投入区間の同一箇所付近に「ATC解放区間」を設け、自動投入方式においてもATC非設備区間の運転を可能なものとする。ATC解放区間は、車両が進入し停止した時点で無信号コードとする設備とする。

車上では、ベルが鳴動し非常ブレーキが動作することにより、乗務員は、ATC切換スイッチを扱うことができ、これを「切位置」とすることによって非設備区間の運転が可能となる。



③ 着発線の設備

駅の着発線は、基本的には進行定位により列車の着発を行うこととなるが、出発進路が定位の場合には、列車が進入し停止した時点で進行を指示する信号コード(25, 45又は80信号)は、停止信号コード(0, 信号)に変更される設備とする。

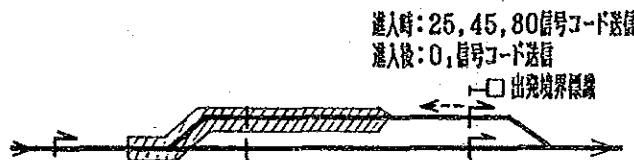

④ 折返線の設備

駅の折返線は、列車進入時には進行を現示する信号コード(25, 45信号等)を送信し、列車が進入し停止した時点で停止信号コードに変更される。同様に、後方からも停止信号コード(0, 信号)が送信される設備とする。

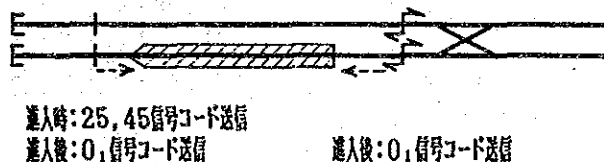

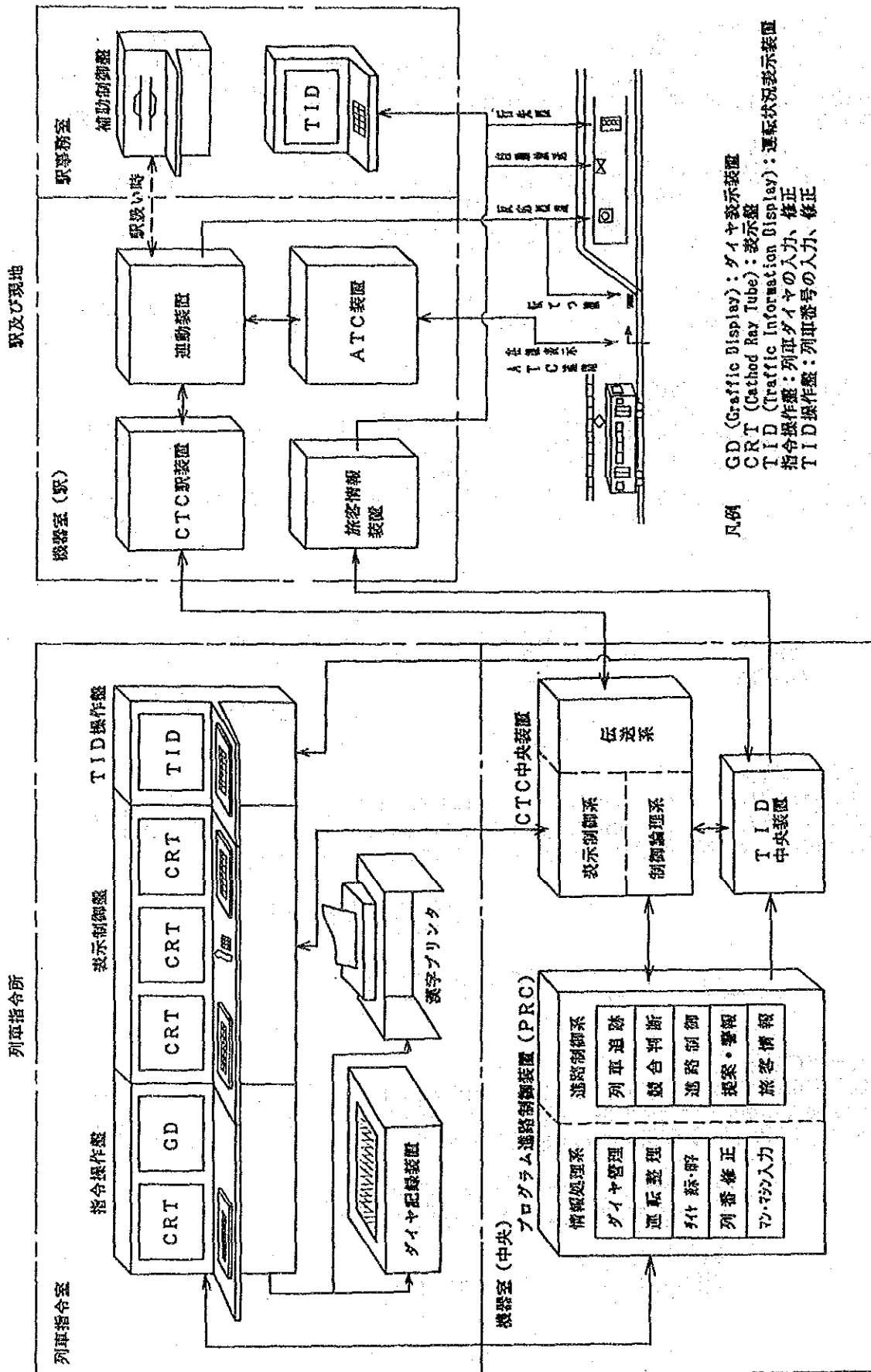

付図 12-16-1 輸送管理装置概略図

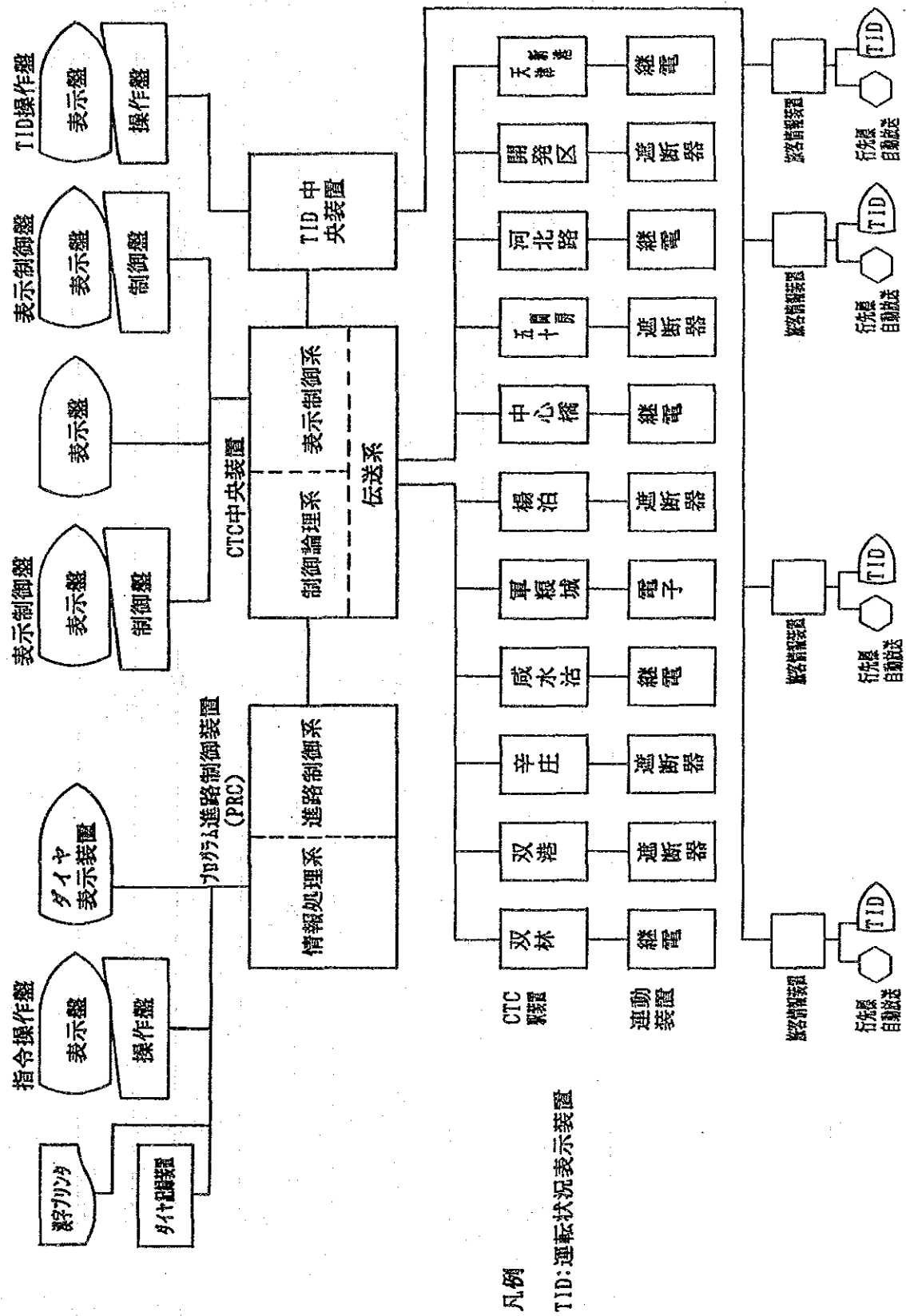

凡例
TID: 運転状況表示装置

付図12-16-2 輸送管理装置機器構成図

付属資料12-17 双林・天津新港間通信設備計画図



凡例

- : 終局
- : 中継

伝送路

通信ケーブル
(0.9mmφ:50線)

指令電話 (列車)

指令電話 (電気)

区間電話
聯区
交換

交換電話

沿線電話

- : 終局(電)
- : 中継(電)

- : 終局電話
- : 中継電話
- : 交換電話
- ◇: 沿線電話
- △: 終局電話
- ▽: 中継電話

電話回線

- : CTC中継
- : 交換
- : 終局電話(電)
- SS: 交換
- △: 終局電話(中央)
- ▽: 中継電話(電)

CTC

変電所

列車無線

模写電燈

時計

旅客情報

- ⊕: 終局電話
- ⊖: 中継電話
- : 交換
- : 終局電話

制御回線

付属資料12-18 通話方式の比較

項目	方式	複信式	半複信式	単信式
概要図				
		凡例 □: 基地局側 □: 移動局側 ▷: スピーカ M: マイク SW: 押しボタン		
取り扱い		◎簡単 双方向同時に送受話ができる。	○慣れを要す A: 複信式と同じ。 B: ボタンを押しながら送話。受話は、ボタンを戻す。	×複雑 A、B交互にボタンを押しながら送話、受話はボタンを戻す。
周波数		2波 (f_1 及び f_2)	2波 (f_1 及び f_2)	1波 (f_1)
電波の出方		通話時は、双方同時に電波を送信している。	A: 常時電波を送信している。 B: 送話時のみ電波を送信。	送話時のみ電波を送信。

第 1 3 章

管理運営計画

付属資料

付属資料13-1 駅要員、乗務員の算定

(1) 駅要員の算定

① 出札窓口数

出札窓口数は、次式による。

$$N = \frac{n}{110 \times T} \times \alpha$$

ただし、

N : 所要窓口数
 n : 発売換算枚数 ($n = \frac{P}{3} \times \beta$)

β : 換算枚数で、電車区間は 0.6 とする。

P : 乗車人員 ($2P/3$ は、定期券等を使用するものとする。)

T : 有効時間帯 (4時~22時の 18 時間とする。)

α : 予備率 (1.5 とする。)

なお、定期券等の発売窓口を別に 1 箇所設ける。 ($2P/3$ に対応するもの。)

② 改札口数

改札口数は、次式による。

ピーク時の乗降人員と旅客の通過速度から算定する。

$$N' = \frac{1}{T} \left(\frac{n_1}{P_1} + \frac{n_2}{P_2} \right) + A$$

ただし、

N' : 所要改札窓口数

T : 3,600 秒

n_1 : ピーク 1 時間の乗車人員

n_2 : 降車人員 ($n_1 = n_2$)

P_1 : 乗車客の単位時間当たり通過人員 (0.7 人/秒)

P_2 : 降車客の (1.0 人/秒)

A : 予備の改札窓口数 (1 箇所とする。)

③ 駅の職員数

駅職員の勤務形態は、日勤又は 2 交替勤務 (中国の例による。) とし、駅長を除き 2 交替勤務を主体とする。

出面数は、駅長、主任を除き出札、改札口数 (改札口の予備は除く。) の 3 割増し (代務、案内等の要員) とする。

1 出面に対する所要定員数は、次により係数を 3.2 とする。

$$\text{係数} = \frac{\text{年間必要業務時間 (19 時間 } \times \text{ 365 日)}}{\text{1 人年間勤務時間 (8 時間 } \times \text{ 270 日)}} = 3.2$$

注. 19 時間は、営業時間に前後 30 分を加えたもの。

270 日は、次による。

$$365 - (52 + 7 + 26 + 10) = 270 \text{ 日}$$

日曜日 祝日 土曜日 0.5 日
日とはもの

(2) 乗務員の算定

乗務員数の算定は、次式による。

$$\text{所要の乗務員数} = \frac{\text{1日の総労働時間}}{\text{1人当たり1日の勤務時間}} \times \text{予備率 (1.4)}$$

1日の総労働時間は、電車列車、回送列車の運転時分及び折返しのための待時分、便乗時分、入出区時の準備時分の総計である。

なお、予備率は、次による。

$$\text{予備率} = \frac{365}{260} \approx 1.4$$

注. 1人1年間の勤務日数は、260日とする。

$$365 - (\underset{\text{日曜日}}{52} + \underset{\text{祝日}}{7} + \underset{\text{土曜日を0.5日としたもの}}{26} + \underset{\text{休日}}{10} + \underset{\text{訓練日}}{10}) = 260 \text{ 日}$$

付属資料13-2 駅業務量、駅要員の算定表

付属資料13-2 駅業務量、駅要員の算定表

年次	項目	駅名	双 林 線	双 津 線	辛 庄 線	咸 水 沽 線	軍 糧 城 線	楊 泊 線	中 心 樓 線	(五 十 間 房 線)	河 北 路 線	合 計	
1986	乗車人員 (人/日) -7- E-71線		32,825	2,655	3,215	20,082	4,283	7,199	11,305	-	29,254	110,808	
			6,236	504	610	3,306	814	1,368	2,148		5,558		
	出札窓口数	5+0	1	1	3+0	1+0	1	1+1	2+0		4+0	営業一室員	
	改札窓口数	4+1	1+1	1+1	3+1	1+1	1+1	1+1	2+1		4+1		
駅 主 任 其 他 の 駅 要 員	駅長		1	1	1	1	1	1	1		1	4 - 4	
	主任	2	1	1	2	2	1	1	1	2	2		
	其他	3	3	3	9	4	4	4	7	12	39		
	其他	13	3	3	9	4	4	4	7	12	55		179
合 計		49	13	13	37	21	16	27		46	222		
2000	乗車人員 (人/日) -7- E-71線		34,255	11,378	18,886	20,887	3,689	7,767	11,843	2,505	29,938	168,552	
			6,508	2,162	3,588	3,965	701	1,476	2,250	476	5,668		486
	出札窓口数	5+0	2+0	3+0	3+0	1+0	1	1+1	2+0	1	5+0	営業一室員	
	改札窓口数	4+1	2+1	3+1	3+1	1+1	1+1	1+1	2+1	1+1	4+1		
駅 主 任 其 他 の 駅 要 員	駅長	1	1	1	1	1	1	1	1		1	9 - 9	
	主任	3	1	1	2	2	1	1	1	2	2		
	其他	13	7	9	9	5	4	4	7	10	34		55
	其他	13	7	9	9	5	4	4	7	10	34		268
合 計		53	27	33	37	24	16	27	13	48	332		
2015	乗車人員 (人/日) -7- E-71線		42,789	16,984	27,818	29,077	5,228	9,985	15,411	3,689	39,337	226,450	
			8,130	3,217	5,285	5,525	993	1,893	2,928	701	7,474		545
	出札窓口数	6+0	3+0	4+0	4+0	1+0	2	1+1	2+0	1	6+0	営業一室員	
	改札窓口数	6+1	2+1	4+1	4+1	1+1	1+1	1+1	2+1	1+1	5+0		
駅 主 任 其 他 の 駅 要 員	駅長	1	1	1	1	1	1	1	1		1	9 - 9	
	主任	3	1	1	2	2	1	1	1	2	2		
	其他	17	8	12	12	5	4	4	7	13	34		58
	其他	17	8	12	12	5	4	4	7	13	34		322
合 計		65	30	43	46	24	16	27	13	59	389		

注1. 駅長は、乗車客10,000人以上の駅に配置する。
 注2. 駅要員は、出札窓口数と改札窓口数の3割を交替等の要員とする。
 注3. 駅名欄の○印は、主要駅を、SWは場内、出発進路を持つ無運動物を示す。
 注4. 出札窓口数欄の○印は、定期券等の発行窓口を示す。

付属資料13-3 乗務員数の算定表

付属資料13-3 乗務員数の算定表

項目	年次	1989	2000	2015	備考
区間(区間番号)		双林 ~ 河北路 (38.7)	双林 ~ 天津新港 (49.55)	双林 ~ 天津新港 (49.55)	
必要列車快速		18 X 30' = 540'	43 X 39.5' = 1,700'	33 X 39.5' = 1,300'	
勤務運転各停		132 X 35' = 4,620'	110 X 45.5' = 5,010' 30 X 36' = 1,080'	118 X 45.5' = 5,370' 20 X 36' = 720'	
時分		*1 550'	1,230'	1,010'	回送列車は、月率1行とする。
計		5,710分	9,020分	8,400分	
折返時分(折返時分)		*2 2,140分	2,010分	2,310分	
(A) 便乗時分		(150/5) X 35' 1,050分	(183/4) X 45' 2,070分	(171/4) X 45' 1,840分	1人仕立は15-4本の厚(回送列車)とする。
準備時分(準備時分)		(150/5 + 3) X 90' 2,970分	(183/4 + 4) X 90' 4,500分	(171/4 + 4) X 90' 4,230分	+3-4は、案内仕立である。 準備時分は、出庫時:50分、入庫時:40分とする。
A 合計		11,870分 (7輛)	17,600分 (7輛)	16,880分 (7輛)	
B 乗務員の勤務時分 (A/B)		420分	420分	420分	
C 必要な乗務員数 (A/B)		(11,870/420 + 3) X 365/260 45人	(17,600/420 + 4) X 365/260 65人	(16,880/420 + 4) X 365/260 与 65人	+3-4は、出庫予定である。 260日は、乗務員の中間換日数である。

*2 : 双林、河北路及び中間駅における折返時分の総計。

*1 (1986) : 20X18' + 16X12' = 550'
 (2000) : 43X18' + 2X12' + 10X22' + 17X12' + 1X10' = 1,230'
 (2015) : 37X18' + 7X22' + 16X12' = 1,010'

付属資料13-4 (1) 要員計画表(非現業)

年次			1986			2000			2015			備 考	
部 課	部課長	係	長主任	課 員	要員計	主任増	課員増	要員計	主任増	課員増	要員計		
所長等 機 務	所長室	主任	4	3	7	-	-	7	-	-	7		
	機 務	機務	3	5	8			8			8		
		庶務 庶務 原生	1 1 1	2 2 2	3 3 3	-	1	4	-	1	5		
	計			6	12	17	-	1	18	-	1	19	
	經 理	庶務	2	3	5		1	6		1	7		
		経理 會計	1 1	6 6	7 6	-	1 1	7 7	-	2 2	9 9		
	計			4	13	17	-	3	20	-	5	25	
	人 事	庶務	2	3	5		1	6		1	7		
		職員 労働 保健	1 1 1	5 2 2	6 3 3	-	2	8 3 3	-	2 1	10 4 3		
	計			5	12	17	-	3	20	-	4	24	
企 画	企画	2	3	5			5			5			
	技術 技術	1 1	3 5	4 6	-		4 6	-		4 6			
計			4	11	15	-	-	15	-	-	15	ソフト面 ハード面	
安全管理	庶務	2	2	4			4			4			
	保安 公安	1 1	4 3	5 4	-	1 1	6 5	-	1 2	7 7			
計			4	9	13	-	2	15	-	3	18		
教 育	庶務	2	2	4			4			4			
	企画 指導	1 1	2 4	3 5	-	1	3 6	-	1	3 7			
計			4	8	12	-	1	13	-	1	14		
資 材	庶務	2	2	4			4			4			
	計画 資材	1 1	3 5	4 6	-	1	4 7	-	1	4 8			
計			4	10	14	-	1	15	-	1	16		
小 計			34	78	112	-	11	123	-	15	138		
運 輸	营 業	庶務	2	3	5			5			5		
		営業 制度 販売 駅務	1 1 2 1	3 3 2 2	4 4 4 3	-	1 1	4 4	-	1 2	4 6		
	計			7	13	20	-	2	22	-	3	25	
運 転	庶務	2	3	5			5			5			
	運用 列車 指令長	1 1 1	3 5 8	4 6 9	-	1 1	6 7 9	-	1	8 9			
計			6	19	24	-	2	26	-	1	27	指令員：2X4	
小 計			12	32	44	-	4	48	-	4	52		
工 務	車 両	庶務	3	3	6			6			6		
		技術 運用 検査 資材	1 1 1 1	3 3 2	4 4 3	-	1 1 1	4 5 4	-	1 1 1	6 6 5		
	計			7	14	21	-	3	24	-	3	27	
施 設	庶務	2	3	5			5			5			
	施設 建築 機械 資材	1 1 1 1	3 5 2 2	4 6 3 2	-	1 1	4 4	-	1 2	4 2			
計			7	16	23	-	3	26	-	-	26		
電 気	庶務	2	3	5			5			5			
	技術 変電 電車 信号 通信 資材 電気 指令	1 1 1 1 1	3 2 3 3 2	4 3 4 4 3	-	1 1 1 1	4 4 5 4 4	-	1 1 1	4 4 4			
計			7	20	27	-	4	31	-	-	31		
小 計			21	50	71	-	10	81	-	3	84		
非 現 業 合 計			67	160	227	-	25	252	-	22	274	対全体：20%	

付屬資料 13-5 管理運営費 原單位

	人件費 (円)				物件費 (円)				備考		
	日本 (民鉄)		天津地下鉄		天津地下鉄		津塘快速鉄道 (案)				
	A 係数	B 係数	B/A	A 係数	B 係数	B/A	C 係数	C/A		C ÷ 36	
G 管理運営費	1 一般管理費 /人・年	723 千円/全額			290 千円/全額	18 千円/全額	1/16	36 千円/全額	1/8	1,000 千円/全額	
	2 給送管理費 /	6,890 千円/全額			1,000 千円/全額			0.2 千円/全額	1/5	0,005 千円/全額	
	3 保守管理費 /	7,730 千円/全額			2,717 千円/全額			27 千円/全額	1/10	750 千円/全額	
	4 運輸費 /	4,180 千円/全額			3,500 千円/全額	0.63 千円/全額	1/6	0.9 千円/全額	1/4	0.025 千円/全額	
	5 運転費 (経費) (動力費)	11,990 千円/全額			1,040 千円/全額	8.3 千円/全額	1/6	0.2 千円/全額	1/5	0.005 千円/全額	日本: 2円/kwh 21/4.2=5
	6 線路保守費 /	5,950 千円/全額			25.9 千円/全額	1.63 千円/全額	1/16	3.2 千円/全額	1/8	0.09 千円/全額	
	7 電路保守費	5,660 千円/全額			10.9 千円/全額	2.63 千円/全額	1/4	2.9 千円/全額	1/4	0.08 千円/全額	
	8 車両保守費	5,700 千円/全額			22.0 千円/全額	2.59 千円/全額	1/8	5.5 千円/全額	1/4	0.15 千円/全額	
	9 合計	4,824 千円/人・年	1,700 千円/人・年	79/1							

付属資料13-6 管理運営費積算表

(単位：千元/年)

項目	年次	1996		2000		2015	
A	営業キロ (km)	38.7		49.55		49.55	
B	列車キロ (千km)	2,376		3,749		3,493	
C	車両キロ (千km)	9,505		14,994		20,958	
D	車両数 (両)	56		84		120	
E	1 総務管理要員	112		123		138	
	2 輸送管理要員	44		48		52	
	3 保守管理要員	71		81		84	
	4 運輸関係要員	333		465		524	
	5 乗務員 (運転士)	45		65		65	
	6 線路保守要員	104		127		127	
	7 電路保守要員	106		130		130	
	8 車両保守要員	191		236		270	
	9 合計 (人)	1,008		1,275		1,390	
F	輸送人員 (人/年)	40,445		61,522		82,654	
G	1 一般管理費	人件費	物件費	人件費	物件費	人件費	物件費
	2 輸送管理費		1,006.0		1,275.0		1,390.0
	3 保守管理費		202.2		307.6		413.3
	4 運輸費		53.3		60.8		63.0
	5 運輸費		1,011.1		1,538.0		2,066.4
	6 動力費		47.5		75.0		104.8
	7 線路保守費		3,057.8		4,607.5		6,058.7
	8 電路保守費		855.4		1,349.5		1,886.3
	9 車両保守費		760.4		1,199.5		1,676.7
	10 合計 (千元)		1,425.7		2,249.1		3,143.8
		1,710.2	8,419.4	2,167.5	12,662.0	2,363.0	16,803.0
	管理運営費合計 (千元)	10,129.6		14,829.5		19,166.0	

注1. 人件費は、1,700 元/人・年とする。(天津地下鉄の実績)

注2. 電力量は、次による。1996: 28,360Mwh 2000: 39,720Mwh 2015: 52,230Mwh

**第 1 4 章 投資規模及び投資工程
付属資料**

付属資料 1 4 - 1 主要単価一覧表

(単位：元)

工事種類	単位	積算単価	外貨比率	内貨の内訳		備考
				労務費	その他	
1) 用地			0	0%	100%	
用地取得 1	㎡ ²	15				農地
家屋移転 1	戸	200				農地 一戸建
用地取得 2	㎡ ²	100				市街地
家屋移転 2	㎡ ²	1,000				市街地 工場 倉庫
家屋移転 3	㎡ ²	2,000				市街地 集合住宅
借地	㎡ ²	4				一時使用
2) 路盤			0			
複線盛土	㎡	873		60%	40%	複線 h = 2m
土留付盛土 1	㎡	6,890		30	70%	単線 h = 3m
土留付盛土 2	㎡	7,640		30	70%	複線 h = 3m
土留付切取	㎡	6,880		30	70%	複線 h = 3m
3) 橋梁			0			
桁式高架橋 (場所打杭)	㎡	11,160		10	90%	一般複線 PC桁 L=20m h=8m 杭 L=12m
桁式高架橋 (場所打杭)	㎡	12,300		10		一般複線 PC桁 L=30m h=8m 杭 L=20m
ラーメン式高架橋 (既成杭)	㎡	10,960		10		複線 柱高 h= 8m 杭 L=10m
ラーメン式高架橋 (既成杭)	㎡	14,030		10		複線 柱高 h= 8m 杭 L=20m
P C 連続桁 (ケーソン)	㎡	55,710		10		ダイヤダーク PC桁 L=4×65m
広場	㎡ ²	30		10		
4) 建築			0			
橋上駅舎	㎡ ²	1,710		10%	90%	駅舎く体
駅舎内装	㎡ ²	800		10		
駅舎付帯設備	㎡ ²	160		10		
乗降場上家	㎡ ²	550		10		
管理棟	㎡ ²	1,500		10		
検修棟	㎡ ²	750		10		
倉庫	㎡ ²	700		10		
技術区棟	㎡ ²	1,000		10		
集合住宅	㎡ ²	750		10		

工事種類	単位	積算単価	外貨比率	内貨の内訳		備考
				労務費	その他	
5) 軌道			0			
50 kg	m	340		2%	98%	単線 碎石道床
43 kg	m	280		2		単線 碎石道床
50 kg 分岐器						
18#片	組	31,000		2		
12#片	組	21,000		2		
12#sc	組	120,000		2		
43 kg 分岐器						
9#片	組	16,000		2		
9#sc	組	89,000		2		
12#sc	組	114,000		2		
6) 電化						
a) 変電設備						双林SS
受電設備	1 式	486,000	0	1%	99%	
変成器設備	1 式	4,932,000	69%	1	99	
き電設備	1 式	5,931,000	93	3	97	
配電設備	1 式	422,000	0	1	99	
被遠制御設備	1 式	375,000	93	4	96	
建物	1 棟	240,000	0	10	90	(150㎡)
b) 電車線路設備						本線関係
支持物	複線					
km当り	km当り	122,400	0	5	95	
き電線	//	376,200	1	1	99	
電車線	//	240,100	0	2	98	
c) 電力設備						本線関係
配電線	複線					
km当り	km当り	119,200	0	3	97	
駅電力設備	駅	169,000	0	1	99	
7) 信号・通信						
a) 信号						
入換信号機	基	195	0	10%	90%	
継電連動装置	組	155,560	0	10		転てつ機：4組
継電連動装置	組	311,110	0	10		転てつ機：8組
継電連動装置	組	466,670	0	10		転てつ機：12組
電気転てつ機	組	3,890	0	10		
信号ケーブル	m	41	0	10		各種
電子連動装置	組	2,333,400	95	100	0%	
列車集中制御装置	組	3,837,500	95	100		中央
列車集中制御装置	組	195,830	95	100		駅
A F 軌道回路	ヶ所	205,840	99	100		
自動進路制御装置	組	10,291,670	95	100		
運転状況表示装置	組	1,152,780	95	100		中央
運転状況表示装置	組	41,670	95	100		駅

工事種類	単位	積算単価	外貨比率	内貨の内訳		備考
				労務費	その他	
b)通信						
搬送端局装置	組	56,250	0	2%	98%	PCM
中継装置	組	10,060	0	2		PCM
指令電話装置	組	6,250	0	2		親装置
指令電話機	個	840	0	3	97%	
交換電話機	個	250	0	3		
区間電話機	個	170	0	3		
沿線電話機	個	8,140	98	100		
通信ケーブル	m	60	0	2	98%	
電子交換機	組	304,700	0	2		容量：400CH
列車無線装置	組	3,916,670	95	100		中央
列車無線装置	組	236,110	95	100		基地局
列車無線装置	個	27,780	95	100		移動局
8) 機械 (車両基地)						
車両自動洗浄装置		70,000	0%	10%	90%	
在姿車輪転削盤		1,000,000	0	10	90	15 t
天井走行クレーン		330,000	0	10	90	
車輪旋盤		550,000	0	10	90	
輪軸旋盤		290,000	0	10	90	
車輪中ぐり盤		100,000	0	10	90	
車両床下機器						
気吹集じん装置		1,000,000	95	100		
ATC試験装置		3,330,000	97	100		
制御装置試験装置		3,330,000	97	100		
列車無線装置		830,000	90	100		
電車試験装置		2,780,000	97	100		
9) 車両	両					
Tc		2,960,000	100%	0%	0%	制御付随車 第一期
M ₁		4,380,000	100	0	0	中間電動車 第一期
M ₂		4,550,000	100	0	0	中間電動車 第一期
Tc		1,670,000	30		100	制御付随車 第二期以降
M ₁		3,150,000	63		100	中間電動車 第二期以降
M ₂		3,230,000	61		100	中間電動車 第二期以降
T		1,320,000	0		100	中間付随車 第二期以降

付属資料 1 4 - 2 日中高架橋単価試算比較表
 (1) 日本の高架橋単価
 (L = 30 m 材工一式)

単位	数量	単価	金額	1m当り単価	備考
コンクリート	270	円	千円	千円	鉄筋コンクリート工
型	960	72,500	19,575	652	躯体 210kg/m ² 85,000円/m ²
鉄	36				基礎 67kg/m ² 35,000円/m ²
根	163	3,700	603		杭打工 円/本
コンクリート杭	72	48,000	4,872		材料費 29,300
小計			25,050		工費 18,600
諸経費	20		5,010		
合計			30,060	千円 1,000	= 27.778元

(2) 中国の高架橋単価
 (L = 30 m 材工一式)

単位	数量	単価	金額	1m当り単価	備考
コンクリート	270	196元	52,920元	11,9520 /30m =3984	日本単価 /中国単価
型	960				4.5倍
鉄	36	1,850	66,600		6倍
根	163	1,67	27,22		1.1倍
コンクリート杭	72	1,650	118,800		
小計			241,042		
諸経費	24		57,850		
合計			298,892	元 9963	2.7倍

高架部標準断面図

L = 3 + 3 x 8 + 3 = 30m

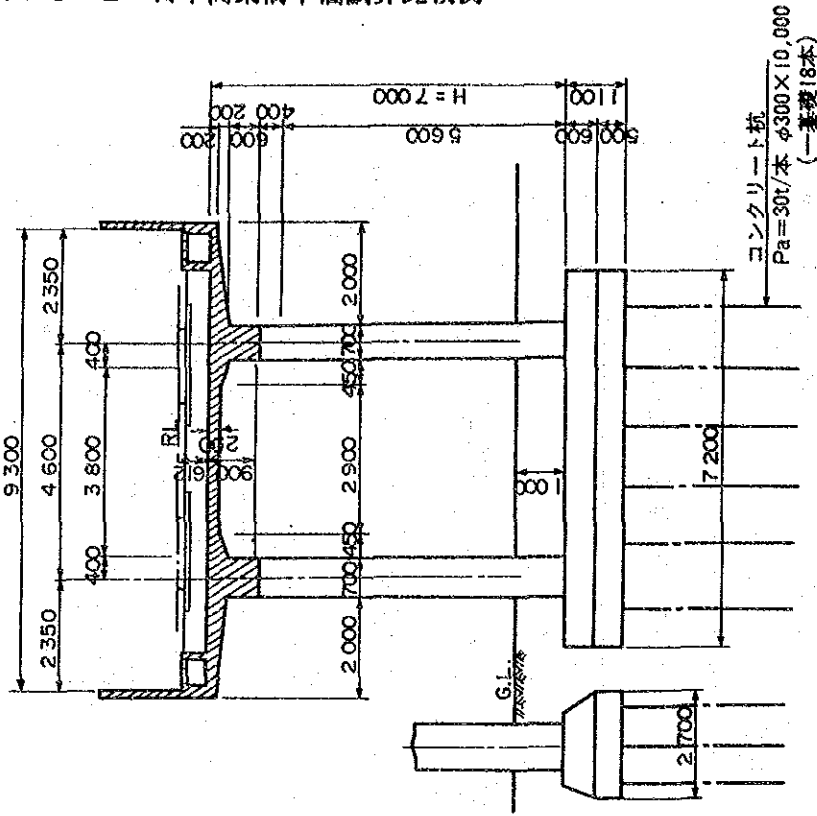

付屬資料 14-3 外貨一覽表

(第一期)

(單位 萬元)

項目	內容	數量	外資額			備考	
			材料	機器	合計		
電力 変電所	変成機設備	4ヶ所		1,186	1,186	変圧器を除く 直流機器	
	き電設備	4		2,281	2,281		
	被遠隔制御装置	4 "		139	139		
	遠隔制御装置	1 "		399	399		
	直流避雷	159ヶ		18	18		
電車線路	合計			4,023	4,023		
信号通信 信号設備	電子連動装置	1組		222	222	中央装置 駅装置 中央装置 駅装置 中央装置 基地局 移動局	
	列車集中制御装置	1		364	364		
	列車集中制御装置	9		167	167		
	運転状況表示装置	1		109	109		
	運転状況表示装置	3		12	12		
	A F軌道回路	260ヶ所		5,301	5,301		
	列車無線装置	1組		372	372		
	同	5		112	112		
	同	28		74	74		
	沿線電話機	31個		26	26		
	旅客情報設備	1式		68	68		
	合計			6,827	6,827		
機械	電車試験装置	1式		270	270		
	床下機器気吹き集塵装置	1		95	95		
	A T C試験装置	1		323	323		
	制御装置試験装置	1		323	323		
	電気指令ブレーキ試験装置	1		75	75		
	弁類試験装置	1		90	90		
	列車無線試験装置	1		75	75		
	その他			259	259		
		合計			1,510		1,510

項目	内容	数量	外資額			備考
			材料	機器	合計	
その他	養成費等		124		124	上記迄の1%
予備費			1,248		1,248	上記迄の10%
車両	制御付随車	28両		8,288	8,288	
	中間電動車	28		12,502	12,502	
	合計	56		20,790	20,790	
総係費			1,726		1,726	上記迄の5%
総計			3,098	33,150	36,248	

(第二期)

項目	内容	数量	外資額			備考
			材料	機器	合計	
信号通信 信号設備	列車集中制 御装置	2組		38	38	駅装置
	運転状況表 示装置	1		4	4	
軌道回路	自動進路制 御装置	1		978	978	駅装置
	A F 軌道回 路	57ヶ所		1,162	1,162	
通信設備	列車無線装 置	1組		23	23	基地局 移動局
	同	14		37	37	
	沿線電話機	9個		8	8	
	旅客情報設 備	1式		21	21	
	合計			2,271	2,271	
その他	養成費等		23		23	上記迄の1%
予備費			229		229	上記迄の10%
車両	制御付随車	14両		630	630	半額分、残り の半額は内貨 充当
	中間電動車	14		2,772	2,772	
	合計	28		3,402	3,402	
総係費			296		296	上記迄の5%
総計			548	5,673	6,221	

2000年以 降の車両 費	中間電動車	18両		3,564	3,564	半額分、残り の半額と付随 車は内貨充当
---------------------	-------	-----	--	-------	-------	----------------------------

付屬資料14-4 建設工事費年区分表

付屬資料14-4 建設工事費年区分表

(單位：萬元)

第一期

金額 項目	1991年		1992年		1993年		1994年		1995年		合計	
	內貨	外貨	內貨	外貨	內貨	外貨	內貨	外貨	內貨	外貨	內貨	外貨
用地	2,002	0	8,009	0							10,011	0
土木	1,421	0	5,682	0	17,994	0	22,255	0			47,352	0
建築					1,505	0	1,914	0	1,140	0	4,559	0
軌道					208	0	1,912	0	1,356	0	3,476	0
電力					99	80	1,688	1,368	3,177	2,575	4,964	4,023
信号通信					19	137	323	2,321	607	4,369	949	6,827
機械									642	1,510	642	1,510
その他									719	124	719	124
計①												
予備費	346		1,383	22	2,002	372	2,837	854	699	7,267	1,248	20,790
車両費						1,485						
合計①												
総係費	190		761	12	1,101	279	1,561	1,435	384	3,997	1,726	36,248
合計②	3,993		15,972	253	23,126	5,862	32,771	30,133	8,074	83,936	36,248	120,184
総計	3,993		15,972	23,379	38,633	38,207	120,184					

金額 項目	1996年		1997年		1998年		1999年		合計		2000年		2003年	
	内貨	外貨	内貨	外貨	内貨	外貨	内貨	外貨	内貨	外貨	内貨	外貨	内貨	外貨
土木			6,337		7,745	0			14,082	0				
建築					377	0	566	0	943	0				
軌道					281	0	523	0	804	0				
電力					571	0	1,060	0	1,630	0				
信号通信					118	795	219	1,476	337	2,271				
機械									0	0				
その他							178	23	178	23				
計①														
予備費			640		918	80	239	149	1,797	229				
車両費	1,944	1,944			1,458	1,458			3,402	3,402	2,241	1,782	2,241	1,782
合計①														
総係費	97	97	352		578	117	132	82	1,159	296				
合計②	2,041	2,041	7,392		12,136	2,458	2,763	1,722	24,332	6,221				
総計	4,082	4,082	7,392		14,594	14,594	4,485	4,485	30,553	30,553	4,023	4,023	4,023	4,023

第 1 5 章 經濟・財務分析
付屬資料

付属資料15-1 時間評価値の設定

時間評価値の設定において使用した月平均労働時間及び非労働時間調整値の算出方法を以下に示す。

(1) 月平均労働時間の算出方法

$$\begin{aligned} \text{月平均労働時間} &= \frac{[365 \text{ 日} - 7 \text{ 日 (記念日)} - 52 \text{ (日曜日)}] \times 8 \text{ 時間/日}}{12 \text{ ヶ月}} \\ &= 204 \text{ 時間} \end{aligned}$$

(2) 非労働時間調整値の算出方法

$$\text{非労働時間調整値} = \text{勤労時間比} + [1 - \text{勤労時間比}] \times 1/3$$

a) 勤労時間比

$$\text{勤労時間比} = \frac{1 \text{ 週間の純粋労働時間}(47.07)}{1 \text{ 週間の活動時間}(84)} = 0.56$$

b) 1 週間の純粋労働時間

$$\text{1 週間の純粋労働時間} = \frac{48 \text{ 時間} \times (365 \text{ 日} - 7 \text{ 日})}{365 \text{ 日}} = 47.07$$

c) 1 週間の活動時間

1日の半分は活動しているものとする。

$$1 \text{ 週間の活動時間} = 12 \text{ 時間/日} \times 7 \text{ 日} = 84 \text{ 時間}$$

$$\therefore \text{非労働時間調整値} = 0.56 + (1 - 0.56) \times 1/3 = 0.7$$

(3) 時間評価値

上記の結果により、乗客1人当たりの時間価値は、以下のとおりである。

$$\text{時間価値} = \frac{102.65 \text{ 元}}{204 \text{ 時間}} \times 0.7 = 0.352 \text{ 元/時間} \cdot \text{人}$$

付表 15-2-1 標準ケース

	1991	1992	1993	1994	1995	1996	1997	1998	1999	2000	2001	2002	2003	2004	2005	2006	2007	2008	2009	2010	2011	2012	2013	2014	2015	2016	2017	2018	2019	2020
INVESTMENT DIFF	4117	16470	23149	38194	29227	3582	7013	13561	-5139	4006	-144	-150	3911	-1310	-95	-150	-95	-150	-10131	-462	-402	-462	-1980	-7110	-390	-246	-246	-246	-3200	-246
WITH	4117	16470	23149	38194	37997	3893	7319	13873	2645	4006	0	0	4006	0	0	0	0	0	0	0	0	0	0	0	0	0	0	0	0	0
LAND ACQUISITION	2202	8810	0	0	0	0	0	0	0	0	0	0	0	0	0	0	0	0	0	0	0	0	0	0	0	0	0	0	0	0
CIVIL WORK	1719	6876	21679	28691	2746	0	6971	9245	0	0	0	0	0	0	0	0	0	0	0	0	0	0	0	0	0	0	0	0	0	0
MACHINERY	0	0	0	0	2367	0	0	0	0	0	0	0	0	0	0	0	0	0	0	0	0	0	0	0	0	0	0	0	0	0
ELECTRIFICATION	0	0	197	3362	6328	0	0	628	1166	0	0	0	0	0	0	0	0	0	0	0	0	0	0	0	0	0	0	0	0	0
SIGNALS & TELECOM	0	0	171	2908	5473	0	0	628	1166	0	0	0	0	0	0	0	0	0	0	0	0	0	0	0	0	0	0	0	0	0
ROLLING STOCK	0	0	0	1485	19305	3893	0	2847	0	4006	0	0	4006	0	0	0	0	0	0	0	0	0	0	0	0	0	0	0	0	0
EDUCATION & TRAINING ETC.	0	0	0	0	933	0	0	0	197	0	0	0	0	0	0	0	0	0	0	0	0	0	0	0	0	0	0	0	0	0
OTHERS	196	784	1102	1748	845	0	348	525	116	0	0	0	0	0	0	0	0	0	0	0	0	0	0	0	0	0	0	0	0	0
SALVAGE VALUE (-)	0	0	0	0	0	0	0	0	0	0	0	0	0	0	0	0	0	0	0	0	0	0	0	0	0	0	0	0	0	56841
WITHOUT	0	0	0	0	8770	311	306	311	7784	0	144	150	95	1310	95	150	95	150	10131	462	402	462	1980	7110	390	246	246	246	3200	246
ROAD VEHICLES	0	0	0	0	2784	311	306	311	1835	0	144	150	95	150	95	150	95	150	2880	462	402	462	1980	0	390	246	246	246	246	246
BUS	0	0	0	0	5987	0	0	0	5949	0	0	0	0	1161	0	0	0	0	7251	0	0	0	0	7110	0	0	0	0	2954	0
OTHERS	0	0	0	0	0	0	0	0	0	0	0	0	0	0	0	0	0	0	0	0	0	0	0	0	0	0	0	0	0	0
SALVAGE VALUE (-)	0	0	0	0	0	0	0	0	0	0	0	0	0	0	0	0	0	0	0	0	0	0	0	0	0	0	0	0	0	33502
OPE & MAINTENANCE COST DIFF	0	0	0	0	0	-1758	-1894	-2025	-2160	-3323	-3295	-3371	-3455	-3494	-3576	-3617	-3698	-3741	-3821	-3863	-3946	-3987	-4068	-4145	-4116	-4268	-4309	-4391	-4433	-4514
WITH	0	0	0	0	0	1013	1107	1201	1295	1483	1511	1540	1569	1598	1627	1656	1685	1714	1743	1772	1800	1829	1858	1887	1916	1945	1974	2003	2032	2061
PERSONNEL COST	0	0	0	0	0	171	180	189	198	216	218	219	220	221	223	224	225	227	228	229	231	232	233	234	236	237	238	240	241	242
ENERGY COST	0	0	0	0	0	305	336	367	398	460	470	480	489	499	509	518	528	538	548	557	567	577	586	596	605	615	625	634	644	654
MAINTENANCE COST	0	0	0	0	0	537	591	645	699	807	823	841	860	878	895	914	932	949	967	986	1002	1020	1039	1057	1075	1093	1111	1129	1147	1165
WITHOUT	0	0	0	0	0	2771	3001	3226	3455	4806	4806	4911	5022	5092	5203	5273	5383	5455	5564	5635	5746	5816	5926	6032	6032	6213	6283	6394	6465	6575
PERSONNEL COST	0	0	0	0	0	993	1105	1214	1325	1981	1981	2032	2086	2120	2174	2208	2261	2296	2349	2384	2437	2471	2525	2576	2576	2664	2698	2752	2786	2840
ENERGY COST	0	0	0	0	0	911	1013	1113	1215	1816	1816	1863	1912	1944	1993	2024	2073	2105	2154	2185	2235	2266	2315	2362	2362	2443	2474	2523	2555	2604
MAINTENANCE COST	0	0	0	0	0	867	883	899	915	1009	1009	1016	1024	1028	1036	1041	1049	1054	1061	1066	1074	1079	1086	1094	1094	1106	1111	1119	1124	1131
TIME SAVING BENEFIT	0	0	0	0	0	5758	6589	7419	8250	9490	9676	9863	10049	10236	10422	10609	10795	10981	11168	11354	11541	11727	11914	12100	12287	12473	12676	12879	13082	13284
NET FLOW	-4117	-16470	-23149	-38194	-29227	3934	1470	-4117	15849	8807	15115	13384	9591	15040	14093	14376	14588	14872	25120	15679	15889	16176	17962	23355	16793	16987	17231	17516	20715	18044
NET PV AT EIRR	-4117	-15363	-20141	-30995	-22123	2777	967	-2529	8908	4706	6537	6222	4159	6084	5317	5059	4788	4553	7174	4176	3948	3749	3883	4709	3158	2980	2819	2673	2949	2396
EIRR %	7.21	7.21	7.21	7.21	7.21	7.21	7.21	7.21	7.21	7.21	7.21	7.21	7.21	7.21	7.21	7.21	7.21	7.21	7.21	7.21	7.21	7.21	7.21	7.21	7.21	7.21	7.21	7.21	7.21	7.21

付表 15-2-2 感度分析ケース 1

	1991	1992	1993	1994	1995	1996	1997	1998	1999	2000	2001	2002	2003	2004	2005	2006	2007	2008	2009	2010	2011	2012	2013	2014	2015	2016	2017	2018	2019	2020
INVESTMENT DIFF	4117	16470	23149	38194	29227	3582	7013	13561	-5139	4006	-144	-150	3911	-1310	-95	-150	-95	-150	-10131	-462	-402	-462	-1980	-7110	-390	-246	-246	-246	-3200	-246
WITH	4117	16470	23149	38194	37997	3893	7319	13873	2645	4006	0	0	4006	0	0	0	0	0	0	0	0	0	0	0	0	0	0	0	0	0
LAND ACQUISITION	2202	8810	0	0	0	0	0	0	0	0	0	0	0	0	0	0	0	0	0	0	0	0	0	0	0	0	0	0	0	0
CIVIL WORK	1719	6876	21679	28691	2746	0	6971	9245	0	0	0	0	0	0	0	0	0	0	0	0	0	0	0	0	0	0	0	0	0	0
MACHINERY	0	0	0	0	2367	0	0	0	0	0	0	0	0	0	0	0	0	0	0	0	0	0	0	0	0	0	0	0	0	0
ELECTRIFICATION	0	0	197	3362	6328	0	0	628	1166	0	0	0	0	0	0	0	0	0	0	0	0	0	0	0	0	0	0	0	0	0
SIGNALS & TELECOM	0	0	171	2908	5473	0	0	628	1166	0	0	0	0	0	0	0	0	0	0	0	0	0	0	0	0	0	0	0	0	0
ROLLING STOCK	0	0	0	1485	19305	3893	0	2847	0	4006	0	0	4006	0	0	0	0	0	0	0	0	0	0	0	0	0	0	0	0	0
EDUCATION & TRAINING ETC.	0	0	0	0	933	0	0	0	197	0	0	0	0	0	0	0	0	0	0	0	0	0	0	0	0	0	0	0	0	0
OTHERS	196	784	1102	1748	845	0	348	525	116	0	0	0	0	0	0	0	0	0	0	0	0	0	0	0	0	0	0	0	0	0
SALVAGE VALUE (-)	0	0	0	0	0	0	0	0	0	0	0	0	0	0	0	0	0	0	0	0	0	0	0	0	0	0	0	0	0	56841
WITHOUT	0	0	0	0	8770	311	306	311	7784	0	144	150	95	1310	95	150	95	150	10131	462	402	462	1980	7110	390	246	246	246	3200	246
ROAD VEHICLES	0	0	0	0	2784	311	306	311	1835	0	144	150	95	150	95	150	95	150	2880	462	402	462	1980	0	390	246	246	246	246	246
BUS	0	0	0	0	5987	0	0	0	5949	0	0	0	0	1161	0	0	0	0	7251	0	0	0	0	7110	0	0	0	0	2954	0
OTHERS	0	0	0	0	0	0	0	0	0	0	0	0	0	0	0	0	0	0	0	0	0	0	0	0	0	0	0	0	0	0
SALVAGE VALUE (-)	0	0	0	0	0	0	0	0	0	0	0	0	0	0	0	0	0	0	0	0	0	0	0	0	0	0	0	0	0	32986
OPE & MAINTENANCE COST DIFF	0	0	0	0	0	-1758	-1894	-2025	-2160	-3323	-3295	-3371	-3455	-3494	-3576	-3617	-3698	-3741	-3821	-3863	-3946	-3987	-4068	-4145	-4116	-4268	-4309	-4391	-4433	-4514
WITH	0	0	0	0	0	1013	1107	1201	1295	1483	1511	1540	1569	1598	1627	1656	1685	1714	1743	1772	1800	1829	1858	1887	1916	1945	1974	2003	2032	2061
PERSONNEL COST	0	0	0	0	0	171	180	189	198	216	218	219	220	221	223	224	225	227	228	229	231	232	233	234	236	237	238	240	241	242
ENERGY COST	0	0	0	0	0	305	336	367	398	460	470	480	489	499	509	518	528	538	548	557	567	577	586							

付表15-2-3 感度分析ケース2

	1991	1992	1993	1994	1995	1996	1997	1998	1999	2000	2001	2002	2003	2004	2005	2006	2007	2008	2009	2010	2011	2012	2013	2014	2015	2016	2017	2018	2019	2020				
INVESTMENT DIFF	4523	18098	25438	41824	31076	3582	7738	14651	-4877	4006	-144	-150	3911	-1310	-95	-150	-95	-150	-10131	-462	-402	-462	-1980	-7110	-390	-246	-246	-246	-3200	-246				
WITH	4523	18098	25438	41824	39847	3893	8043	14962	2907	4006	0	0	4006	0	0	0	0	0	0	0	0	0	0	0	0	0	0	0	0	0	0			
LAND ACQUISITION	2419	9881	0	0	0	0	0	0	0	0	0	0	0	0	0	0	0	0	0	0	0	0	0	0	0	0	0	0	0	0	0			
CIVIL WORK	1889	7556	23823	31529	3018	0	7660	10159	0	0	0	0	0	0	0	0	0	0	0	0	0	0	0	0	0	0	0	0	0	0	0	0		
MACHINERY	0	0	0	2601	0	0	0	0	0	0	0	0	0	0	0	0	0	0	0	0	0	0	0	0	0	0	0	0	0	0	0	0		
ELECTRIFICATION	0	0	216	3695	6954	0	0	690	1281	0	0	0	0	0	0	0	0	0	0	0	0	0	0	0	0	0	0	0	0	0	0	0	0	
SIGNALS & TELECOM	0	0	188	3196	6014	0	0	690	1281	0	0	0	0	0	0	0	0	0	0	0	0	0	0	0	0	0	0	0	0	0	0	0	0	0
ROLLING STOCK	0	0	0	1485	19305	3893	0	2847	0	4006	0	0	4006	0	0	0	0	0	0	0	0	0	0	0	0	0	0	0	0	0	0	0	0	0
EDUCATION & TRAINING ETC.	0	0	0	0	1026	0	0	0	216	0	0	0	0	0	0	0	0	0	0	0	0	0	0	0	0	0	0	0	0	0	0	0	0	0
OTHERS	216	861	1211	1920	929	0	383	576	128	0	0	0	0	0	0	0	0	0	0	0	0	0	0	0	0	0	0	0	0	0	0	0	0	0
SALVAGE VALUE (-)	0	0	0	0	0	0	0	0	0	0	0	0	0	0	0	0	0	0	0	0	0	0	0	0	0	0	0	0	0	0	0	0	56841	0
WITHOUT	0	0	0	0	8770	311	306	311	7784	0	144	150	95	1310	95	150	95	150	10131	462	402	462	1980	7110	390	246	246	246	3200	246	0	0	0	
ROAD VEHICLES BUS	0	0	0	0	2784	311	306	311	1835	0	144	150	95	150	95	150	95	150	2880	462	402	462	1980	0	390	246	246	246	246	246	246	246	246	246
OTHERS	0	0	0	0	5987	0	0	0	5949	0	0	0	0	1161	0	0	0	0	7251	0	0	0	0	7110	0	0	0	0	0	0	0	0	2954	0
SALVAGE VALUE (-)	0	0	0	0	0	0	0	0	0	0	0	0	0	0	0	0	0	0	0	0	0	0	0	0	0	0	0	0	0	0	0	0	33502	0
OPE & MAINTENANCE COST DIFF	0	0	0	0	0	-1758	-1894	-2025	-2160	-3323	-3295	-3371	-3453	-3494	-3576	-3617	-3698	-3741	-3821	-3863	-3946	-3987	-4068	-4145	-4116	-4268	-4309	-4391	-4433	-4514				
WITH	0	0	0	0	0	1013	1107	1201	1295	1483	1511	1540	1569	1598	1627	1656	1685	1714	1743	1772	1800	1829	1858	1887	1916	1945	1974	2003	2032	2061				
PERSONNEL COST	0	0	0	0	0	171	180	189	198	216	218	219	220	221	223	224	225	227	228	229	231	232	233	234	236	237	238	240	241	242				
ENERGY COST	0	0	0	0	0	305	336	367	398	460	470	480	489	499	509	518	528	538	548	557	567	577	586	596	605	615	625	634	644	654				
MAINTENANCE COST	0	0	0	0	0	537	591	645	699	807	823	841	860	878	895	914	932	949	967	986	1002	1020	1039	1057	1075	1093	1111	1129	1147	1165				
WITHOUT	0	0	0	0	0	2771	3001	3226	3455	4806	4806	4911	5022	5092	5203	5273	5383	5455	5564	5635	5746	5816	5926	6032	6032	6213	6283	6394	6465	6575				
PERSONNEL COST	0	0	0	0	0	993	1105	1214	1325	1981	1981	2032	2086	2120	2174	2208	2261	2296	2349	2384	2437	2471	2525	2576	2576	2664	2698	2752	2786	2840				
ENERGY COST	0	0	0	0	0	911	1013	1113	1215	1816	1816	1863	1912	1944	1993	2024	2073	2105	2154	2185	2235	2266	2315	2362	2362	2443	2474	2523	2555	2604				
MAINTENANCE COST	0	0	0	0	0	867	883	899	915	1009	1009	1016	1024	1028	1036	1041	1049	1054	1061	1066	1074	1079	1086	1094	1094	1106	1111	1119	1124	1131				
TIME SAVING BENEFIT	0	0	0	0	0	6334	7240	8161	9075	10439	10644	10849	11054	11259	11464	11669	11875	12080	12285	12490	12695	12900	13105	13310	13516	13721	13944	14167	14390	14613				
NET FLOW	-4523	-18098	-25438	-41824	-31076	4510	1404	-4465	16112	9756	14083	14370	10596	16063	15135	15436	15668	15971	26237	16815	17043	17349	19153	24565	18022	18235	18449	18804	22023	19373				
NET PV AT EIRR	-4523	-16775	-21854	-33303	-22936	3085	890	-2624	8776	4925	6589	6232	4259	5985	5227	4940	4648	4391	6687	3972	3731	3521	3602	4282	2912	2731	2568	2419	2626	2141				
EIRR %	7.89	7.89	7.89	7.89	7.89	7.89	7.89	7.89	7.89	7.89	7.89	7.89	7.89	7.89	7.89	7.89	7.89	7.89	7.89	7.89	7.89	7.89	7.89	7.89	7.89	7.89	7.89	7.89	7.89	7.89	7.89	7.89	7.89	7.89

付表15-2-4 感度分析ケース3

	1991	1992	1993	1994	1995	1996	1997	1998	1999	2000	2001	2002	2003	2004	2005	2006	2007	2008	2009	2010	2011	2012	2013	2014	2015	2016	2017	2018	2019	2020					
INVESTMENT DIFF	4523	18098	25438	41824	31076	3582	7738	14651	-4877	4006	-144	-150	3911	-1310	-95	-150	-95	-150	-10131	-462	-402	-462	-1980	-7110	-390	-246	-246	-246	-3200	-246					
WITH	4523	18098	25438	41824	39847	3893	8043	14962	2907	4006	0	0	4006	0	0	0	0	0	0	0	0	0	0	0	0	0	0	0	0	0	0	0	0		
LAND ACQUISITION	2419	9881	0	0	0	0	0	0	0	0	0	0	0	0	0	0	0	0	0	0	0	0	0	0	0	0	0	0	0	0	0	0	0		
CIVIL WORK	1889	7556	23823	31529	3018	0	7660	10159	0	0	0	0	0	0	0	0	0	0	0	0	0	0	0	0	0	0	0	0	0	0	0	0	0	0	
MACHINERY	0	0	0	2601	0	0	0	0	0	0	0	0	0	0	0	0	0	0	0	0	0	0	0	0	0	0	0	0	0	0	0	0	0	0	
ELECTRIFICATION	0	0	216	3695	6954	0	0	690	1281	0	0	0	0	0	0	0	0	0	0	0	0	0	0	0	0	0	0	0	0	0	0	0	0	0	0
SIGNALS & TELECOM	0	0	188	3196	6014	0	0	690	1281	0	0	0	0	0	0	0	0	0	0	0	0	0	0	0	0	0	0	0	0	0	0	0	0	0	0
ROLLING STOCK	0	0	0	1485	19305	3893	0	2847	0	4006	0	0	4006	0	0	0	0	0	0	0	0	0	0	0	0	0	0	0	0	0	0	0	0	0	0
EDUCATION & TRAINING ETC.	0	0	0	0	1026	0	0	0	216	0	0	0	0	0	0	0	0	0	0	0	0	0	0	0	0	0	0	0	0	0	0	0	0	0	
OTHERS	216	861	1211	1920	929	0	383	576	128	0	0	0	0	0	0	0	0	0	0	0	0	0	0	0	0	0	0	0	0	0	0	0	0	0	
SALVAGE VALUE (-)	0	0	0	0	0	0	0	0	0	0	0	0	0	0	0	0	0	0	0	0	0	0	0	0	0	0	0	0	0	0	0	0	0	57620	0
WITHOUT	0	0	0	0	8770	311	306	311	7784	0	144	150	95	1310	95	150	95	150	10131	462	402	462	1980	7110	390	246	246								

付表15-2-5 感度分析ケース4

	1991	1992	1993	1994	1995	1996	1997	1998	1999	2000	2001	2002	2003	2004	2005	2006	2007	2008	2009	2010	2011	2012	2013	2014	2015	2016	2017	2018	2019	2020
INVESTMENT DIFF	4523	18098	25438	41824	31076	3582	7738	14651	-4877	4006	-144	-150	3911	-1310	-95	-150	-95	-150	-10131	-462	-402	-462	-1980	-7110	-390	-246	-246	246	-3200	-246
WITH	4523	18098	25438	41824	39847	3893	8043	14962	2907	4006	0	0	4006	0	0	0	0	0	0	0	0	0	0	0	0	0	0	0	0	0
LAND ACQUISITION	2419	9681	0	0	0	0	0	0	0	0	0	0	0	0	0	0	0	0	0	0	0	0	0	0	0	0	0	0	0	0
CIVIL WORK	1889	7556	23823	31529	3018	0	7660	10159	0	0	0	0	0	0	0	0	0	0	0	0	0	0	0	0	0	0	0	0	0	0
MACHINERY	0	0	0	0	2601	0	0	0	0	0	0	0	0	0	0	0	0	0	0	0	0	0	0	0	0	0	0	0	0	0
ELECTRIFICATION	0	0	216	3695	6954	0	0	690	1281	0	0	0	0	0	0	0	0	0	0	0	0	0	0	0	0	0	0	0	0	0
SIGNALS & TELECOM	0	0	188	3196	6014	0	0	690	1281	0	0	0	0	0	0	0	0	0	0	0	0	0	0	0	0	0	0	0	0	0
ROLLING STOCK	0	0	0	1485	19305	3893	0	2847	0	4006	0	0	4006	0	0	0	0	0	0	0	0	0	0	0	0	0	0	0	0	0
EDUCATION & TRAINING ETC.	0	0	0	0	1026	0	0	0	216	0	0	0	0	0	0	0	0	0	0	0	0	0	0	0	0	0	0	0	0	0
OTHERS	215	861	1211	1920	929	0	383	576	128	0	0	0	0	0	0	0	0	0	0	0	0	0	0	0	0	0	0	0	0	0
SALVAGE VALUE (-)	0	0	0	0	0	0	0	0	0	0	0	0	0	0	0	0	0	0	0	0	0	0	0	0	0	0	0	0	0	56841
WITHOUT	0	0	0	0	8770	311	306	311	7784	0	144	150	95	1310	95	150	95	150	10131	462	402	462	1980	7110	390	246	246	246	3200	246
ROAD VEHICLES BUS	0	0	0	0	2784	311	306	311	1835	0	144	150	95	150	95	150	95	150	2880	462	402	462	1980	0	390	246	246	246	246	246
OTHERS	0	0	0	0	5987	0	0	0	5949	0	0	0	0	1161	0	0	0	0	7251	0	0	0	0	7110	0	0	0	0	2954	0
SALVAGE VALUE (-)	0	0	0	0	0	0	0	0	0	0	0	0	0	0	0	0	0	0	0	0	0	0	0	0	0	0	0	0	0	32502
OPER & MAINTENANCE COST DIFF	0	0	0	0	0	-1758	-1894	-2025	-2160	-3323	-3295	-3371	-3453	-3494	-3576	-3617	-3698	-3741	-3821	-3863	-3946	-3987	-4068	-4145	-4116	-4268	-4309	-4391	-4433	-4514
WITH	0	0	0	0	0	1013	1107	1201	1295	1483	1511	1540	1569	1598	1627	1656	1685	1714	1743	1772	1800	1829	1858	1887	1916	1945	1974	2003	2032	2061
PERSONNEL COST	0	0	0	0	0	171	180	189	196	216	218	219	220	221	223	224	225	227	228	229	231	232	233	234	235	237	238	240	241	242
ENERGY COST	0	0	0	0	0	305	336	367	398	460	470	480	489	499	509	518	528	538	548	557	567	577	586	596	605	615	625	634	644	654
MAINTENANCE COST	0	0	0	0	0	537	591	645	699	807	823	841	860	878	895	914	932	949	967	986	1002	1020	1039	1057	1075	1093	1111	1129	1147	1165
WITHOUT	0	0	0	0	0	2771	3001	3226	3455	4806	4806	4911	5022	5092	5203	5273	5383	5455	5564	5635	5746	5816	5926	6032	6032	6213	6283	6394	6465	6575
PERSONNEL COST	0	0	0	0	0	993	1105	1214	1325	1981	1981	2032	2086	2120	2174	2208	2261	2296	2349	2384	2437	2471	2525	2576	2576	2664	2698	2752	2786	2840
ENERGY COST	0	0	0	0	0	911	1013	1113	1215	1816	1816	1863	1912	1944	1993	2024	2073	2105	2154	2185	2235	2266	2315	2362	2443	2474	2523	2555	2604	2654
MAINTENANCE COST	0	0	0	0	0	867	883	899	915	1009	1009	1016	1024	1028	1036	1041	1049	1054	1061	1066	1074	1079	1086	1094	1094	1106	1111	1119	1124	1131
TIME SAVING BENEFIT	0	0	0	0	0	6334	7248	8161	9075	10439	10644	10849	11054	11259	11464	11669	11875	12080	12285	12490	12695	12900	13105	13310	13516	13721	13944	14167	14390	14613
NET FLOW	-4523	-18098	-25438	-41824	-31076	4510	1404	-4465	16112	9756	14083	14370	10596	16063	15135	15436	15668	15971	26237	16815	17043	17349	19153	24565	18022	19235	13499	18804	22023	19373
NET PV AT EIRR	-4523	-16839	-22021	-33686	-23288	3144	910	-2695	9047	5094	6845	6498	4458	6288	5513	5231	4940	4685	7161	4270	4027	3814	3917	4674	3191	3004	2835	2681	2922	2391
EIRR %	7.48	7.48	7.48	7.48	7.48	7.48	7.48	7.48	7.48	7.48	7.48	7.48	7.48	7.48	7.48	7.48	7.48	7.48	7.48	7.48	7.48	7.48	7.48	7.48	7.48	7.48	7.48	7.48	7.48	7.48

付表15-2-6 感度分析ケース5

	1991	1992	1993	1994	1995	1996	1997	1998	1999	2000	2001	2002	2003	2004	2005	2006	2007	2008	2009	2010	2011	2012	2013	2014	2015	2016	2017	2018	2019	2020	
INVESTMENT DIFF	4523	18098	25438	41824	31076	3582	7738	14651	-4877	4006	-144	-150	3911	-1310	-95	-150	-95	-150	-10131	-462	-402	-462	-1980	-7110	-390	-246	-246	246	-3200	-246	
WITH	4523	18098	25438	41824	39847	3893	8043	14962	2907	4006	0	0	4006	0	0	0	0	0	0	0	0	0	0	0	0	0	0	0	0	0	0
LAND ACQUISITION	2419	9681	0	0	0	0	0	0	0	0	0	0	0	0	0	0	0	0	0	0	0	0	0	0	0	0	0	0	0	0	
CIVIL WORK	1889	7556	23823	31529	3018	0	7660	10159	0	0	0	0	0	0	0	0	0	0	0	0	0	0	0	0	0	0	0	0	0	0	
MACHINERY	0	0	0	0	2601	0	0	0	0	0	0	0	0	0	0	0	0	0	0	0	0	0	0	0	0	0	0	0	0	0	
ELECTRIFICATION	0	0	216	3695	6954	0	0	690	1281	0	0	0	0	0	0	0	0	0	0	0	0	0	0	0	0	0	0	0	0	0	
SIGNALS & TELECOM	0	0	188	3196	6014	0	0	690	1281	0	0	0	0	0	0	0	0	0	0	0	0	0	0	0	0	0	0	0	0	0	
ROLLING STOCK	0	0	0	1485	19305	3893	0	2847	0	4006	0	0	4006	0	0	0	0	0	0	0	0	0	0	0	0	0	0	0	0	0	
EDUCATION & TRAINING ETC.	0	0	0	0	1026	0	0	0	216	0	0	0	0	0	0	0	0	0	0	0	0	0	0	0	0	0	0	0	0	0	
OTHERS	215	861	1211	1920	929	0	383	576	128	0	0	0	0	0	0	0	0	0	0	0	0	0	0	0	0	0	0	0	0	0	
SALVAGE VALUE (-)	0	0	0	0	0	0	0	0	0	0	0	0	0	0	0	0	0	0	0	0	0	0	0	0	0	0	0	0	0	57620	
WITHOUT	0	0	0	0	8770	311	306	311	7784	0	144	150	95	1310	95	150	95	150	10131	462	402	462	1980	7110	390	246	246	246	3200	246	
ROAD VEHICLES BUS	0	0	0	0	2784	311	306	311	1835	0	144	150	95	150	95	150	95	150	2880	462	402	462	1980	0	390	246	246	246	246	246	
OTHERS	0	0	0	0	5987	0	0	0	5949	0	0	0	0	1161	0	0	0	0	7251	0	0	0	0	7110	0	0	0	0	2954	0	
SALVAGE VALUE (-)	0	0	0	0	0	0	0	0	0	0	0	0	0	0	0	0	0	0	0	0	0	0	0	0	0	0	0	0	0	32986	
OPER & MAINTENANCE COST DIFF	0	0	0	0	0	-1758	-1894	-2025	-2160	-3323	-3295	-3371	-3453	-3494	-3576	-3617	-3698	-3741	-3821	-3863	-3946	-3987	-4068	-4145	-4116	-4268	-4309	-4391	-4433	-4514	
WITH	0	0	0	0	0	1013	1107	1201	1295	1483	1511	1540	1569	1598	1627	1656	1685	1714	1743	1772	1800	1829	1858	1887	1916	1945	1974	2003	2032	2061	
PERSONNEL COST	0	0	0	0	0	171	180	189	196	216	218	219	220	221	223	224	225	227	228	229	231	232	233	234	235	237	238	240	241	242	
ENERGY COST	0	0	0	0	0	305	336	367	398	460	470	480	489	499	509	518	528	538	548	557	567	577	586	596	605	615	625	634	644	654	
MAINTENANCE COST	0	0	0	0	0	537	591	645	699	807	823	841	860	878	895	914	932	949	967	986	1002	1020	1039	1057	1075	1093	1111	1129	1147	1165	
WITHOUT	0	0	0	0	0	2771	3001	3226	3455	4806	4806	4911																			

(UNIT : 10000 YUAN)

Table with 28 columns (1991-2020, TOTAL) and multiple rows for Profit & Loss Statement, Investment Total, Finance Program, and Cash Flow Statement. Rows include 10000 PERSON-KM PER YEAR, OPERATING PROFIT, OPERATING REVENUE, OPERATING EXPENSE, and various cost categories.

.. FINANCIAL ANALYSIS FOR THE TIANJIN - TANGGU RAILWAY PROJECT ..
 (UNIT : 10000 YUAN)

付表15-3-3 感度分析ケース2

	1991	1992	1993	1994	1995	1996	1997	1998	1999	2000	2001	2002	2003	2004	2005	2006	2007	2008	2009	2010	2011	2012	2013	2014	2015	2016	2017	2018	2019	2020	TOTAL				
10000 PERSON-KM PER YEAR	0	0	0	0	0	115729	132422	149116	165800	190719	194468	198214	201961	205709	209456	213204	216951	220699	224447	228194	231942	235690	239437	243184	246932	246932	246932	246932	246932	246932	520930				
PROFIT & LOSS STATEMENT																																			
OPERATING PROFIT	0	0	0	0	0	338	1020	1544	2234	2361	3883	4835	3976	4128	4588	4740	4893	5085	5238	5390	5543	5635	5848	6008	6153	6860	6860	6860	6860	6860	6860	117001			
OPERATING REVENUE	0	0	0	0	0	5786	6821	7456	8290	9536	9723	9911	10099	10285	10473	10660	10848	11035	11222	11410	11597	11784	11972	12159	12347	12347	12347	12347	12347	12347	264947				
OPERATING EXPENSE	0	0	0	0	0	5263	5380	5673	5790	6668	5528	5557	5790	5827	5549	5578	5607	5595	5624	5653	5682	5711	5740	5769	5798	5090	5090	5090	5090	5090	139441				
PERSONNEL COST	0	0	0	0	0	171	182	194	205	217	218	219	221	222	223	225	226	227	228	230	231	232	234	235	236	236	236	236	236	236	5550				
COST OF SUPPLIES	0	0	0	0	0	842	948	1054	1160	1266	1294	1321	1349	1377	1404	1432	1459	1487	1515	1542	1570	1597	1625	1653	1680	1680	1680	1680	1680	1680	36977				
GENERAL ADMINIST. COST	0	0	0	0	0	101	107	114	121	128	128	129	130	131	131	132	133	134	134	135	136	137	137	138	139	139	139	139	139	139	3270				
TRANSPORT ADMIN. COST	0	0	0	0	0	20	23	25	28	31	31	32	33	34	34	35	36	36	37	38	39	39	40	41	41	41	41	41	41	880					
MAINTENANCE ADMIN. COST	0	0	0	0	0	5	6	6	6	6	6	6	6	6	6	6	6	6	6	6	6	6	6	6	6	6	6	6	6	153					
TRANSPORT COST	0	0	0	0	0	101	114	127	141	154	157	161	164	168	171	175	178	182	186	189	193	196	200	203	207	207	207	207	207	4400					
OPERATING COST	0	0	0	0	0	311	350	389	429	468	478	488	498	508	518	527	537	547	557	567	577	587	597	606	616	616	616	616	616	13237					
- ELECTRIC POWER COST	0	0	0	0	0	306	345	383	422	461	478	488	498	499	509	519	528	538	548	557	567	577	587	596	606	606	606	606	606	13018					
- OTHER OPERATING COST	0	0	0	0	0	5	5	6	7	7	8	8	8	8	8	8	8	8	8	9	9	10	10	10	10	10	10	10	10	219					
TRACK MAINTENANCE COST	0	0	0	0	0	86	98	110	123	135	139	142	148	149	153	156	160	164	167	171	174	178	181	185	189	189	189	189	189	3948					
ELECTRIC FACILITY MAINT.	0	0	0	0	0	76	87	98	109	120	123	126	129	133	136	139	142	145	149	152	155	158	161	164	168	168	168	168	168	3509					
ROLLING STOCK MAINT.	0	0	0	0	0	143	163	184	204	225	231	237	243	249	255	261	267	273	279	285	291	296	302	308	314	314	314	314	314	6580					
DEPRECIATION	0	0	0	0	0	4250	4250	4425	4425	5385	4016	4016	4229	4229	3921	3921	3921	3881	3881	3881	3881	3881	3881	3881	3881	3881	3881	3881	3881	97906					
SALES TAX ETC.	0	0	0	0	0	186	213	239	266	306	312	318	324	338	336	342	340	354	368	366	372	378	384	390	396	396	396	396	396	8505					
INTEREST	0	0	0	0	0	0	0	0	0	0	0	0	945	897	850	802	754	855	800	744	689	634	624	567	509	451	393	336	278	220	11348				
NET PROFIT	0	0	0	0	0	338	1020	1544	2234	2361	3883	4835	3930	3231	3738	3939	4139	4230	4438	4646	4954	5062	5223	5433	5644	6409	6467	6525	6582	6640	105653				
INVESTMENT TOTAL																																			
FOREIGN TOTAL	0	0	251	5820	30177	2041	0	2449	1731	1871	0	0	1871	0	0	0	0	0	0	0	0	0	0	0	1678	0	0	0	1213	8465	0	1458	0	1782	60813
LOCAL TOTAL	3953	15813	23149	32447	8826	2041	7319	12033	2939	2353	0	0	2353	0	0	0	0	0	0	0	0	0	0	388	0	0	0	121	10150	0	1458	0	2241	127403	
LAND ACQUISITION	2202	8010	0	0	0	0	0	0	0	0	0	0	0	0	0	0	0	0	0	0	0	0	0	0	0	0	0	0	0	0	0	0	0	11012	
CIVIL WORK	1563	8250	21670	20691	2745	0	6971	9244	1197	0	0	0	0	0	0	0	0	0	0	0	0	0	0	0	0	0	0	0	0	0	0	0	0	78339	
MACHINERY	0	0	0	0	2367	0	0	0	0	0	0	0	0	0	0	0	0	0	0	0	0	0	0	0	0	2367	0	0	0	0	0	0	0	4734	
ELECTRIFICATION	0	0	190	3361	6327	0	0	628	1166	0	0	0	0	0	0	0	0	0	0	0	0	0	0	0	0	2640	0	0	0	0	0	0	0	14319	
SIGNALS & TELECOM.	0	0	171	2908	5474	0	0	1004	1863	0	0	0	0	0	0	0	0	0	0	0	0	2066	0	0	1410	0	0	0	0	0	0	0	0	14896	
ROLLING STOCK	0	0	0	1405	19305	3888	0	2916	0	4023	0	0	4023	0	0	0	0	0	0	0	0	0	0	0	0	13608	0	2916	0	4023	56187				
EDUCATION & TRAINING ETC.	0	0	0	0	927	0	0	0	221	0	0	0	0	0	0	0	0	0	0	0	0	0	0	0	0	0	0	0	0	0	0	0	1148		
OTHERS	188	753	1102	1822	1857	194	349	690	222	201	0	0	201	0	0	0	0	0	0	0	0	0	0	0	0	0	0	0	0	0	0	0	7580		
SALVAGE VALUE (-)	0	0	0	0	0	0	0	0	0	0	0	0	0	0	0	0	0	0	0	0	0	0	0	0	0	0	0	0	0	0	0	0	70330	70330	
FINANCE PROGRAM																																			
FINANCE IN FOREIGN CCY.																																			
BORROWING	0	0	251	5820	30177	2041	0	2449	1731	1871	0	0	1871	0	0	0	0	0	0	0	0	0	0	0	0	0	0	0	0	0	0	0	0	46211	
REPAYMENT	0	0	0	0	0	0	0	0	0	0	0	0	1914	1914	1914	1914	1914	2217	2217	2217	2217	2217	2311	2311	2311	2311	2311	2311	2311	2311	2311	2311	39141		
LOAN BALANCE	0	0	251	6871	36248	38289	38289	40738	42468	44339	44339	44339	44296	42382	40467	38553	36638	34421	32204	29987	27770	25553	23243	20932	18622	16311	14001	11690	9380	7069	0	0			
INTEREST	0	0	0	0	0	0	0	0	0	0	0	945	897	850	802	754	855	800	744	689	634	624	567	509	451	393	336	278	220	11348	0	0			
INT. DURING CONSTRUCTION	0	0	0	0	0	0	0	0	0	0	0	0	0	0	0	0	0	0	0	0	0	0	0	0	0	0	0	0	0	0	0	0	0		
FINANCE IN LOCAL CURRENCY																																			
EQUITY CONTRIBUTION	3953	15813	22898	32447	8826	2041	7319	12033	2939	2353	0	0	2353	0	0	0	0	0	0	0	0	0	0	0	0	0	0	0	0	0	0	0	0	112975	
EQUITY BALANCE	3953	19766	42664	75111	83937	85978	93208	105331	108269	110622	110622	110622	112975	112975	112975	112975	112975	112975	112975	112975	112975	112975	112975	112975	112975	112975	112975	112975	112975	112975	112975	112975	112975		
CASH FLOW STATEMENT																																			
NET CASH FLOW	0	0	0	0	0	4588	5278	5968	6659	7747	7899	8052	5345	5545	5745	5945	6146	5894	6102	6310	4452	6726	6794	7004	5805	-11343	7330	4472	7445	73810	205717				
CUMULATIVE NET CASH FLOW	0	0	0	0	0	4588	9866	15834	22493	30240	38139	46191	51536	57080	62826	68771	74917	80811	86913	93223	97675	104401	111195	118199	124003	112661	119990	124462	131907	205717	0	0			
CASH IN																																			
OPERATING PROFIT	0	0	0	0	0	338	1020	1544	2234	2361	3883	4835	3976	4128	4588	4740	4893	5085	5238	5390	5543	5695	5848	6008	6153	6860	6860	6860	6860	6860	6860	117001			
DEPRECIATION	0	0	0	0	0	4250	4250	4425	4425	5385	4016	4016	4229	4229	3921	3921	3921	3881	3881	3881	3881	3881	3881	3881	3881	3881	3881	3881	3881	3881	3881	3881	97906		
BORROWING	0	0	251	5820	30177	2041	0	2449	1731	1871	0	0	1871	0	0	0	0	0	0	0	0	0	0	0	0	1678	0	0	0	0	0	0	0	46211	
EQUITY CONTRIBUTION	3953	15813	22898	32447	8826	2041	7319	12033	2939	2353	0	0	2353	0	0	0	0	0	0	0	0	0	0	0	0	0	0	0	0	0	0	0	0	112975	
CASH OUT																																			
INVESTMENT	3953	15813	23149	32447	39003	4082	7319	14481	4669	4224	0	0	4224	0	0	0	0	0	0	0	2066	0	0	0	1410	18615	0</								

(UNIT : 10000 YUAN)

	1991	1992	1993	1994	1995	1996	1997	1998	1999	2000	2001	2002	2003	2004	2005	2006	2007	2008	2009	2010	2011	2012	2013	2014	2015	2016	2017	2018	2019	2020	TOTAL										
10000 PERSON-KM PER YEAR	0	0	0	0	0	105200	120303	135559	150735	173300	176787	180194	183601	187008	190415	193822	197229	200635	204042	207449	210856	214263	217670	221077	224484	224484	224484	224484	224484	224484	4017216										
PROFIT & LOSS STATEMENT																																									
OPERATING PROFIT	0	0	0	0	0	80	697	1139	1756	1839	3242	3378	3302	3438	3857	3993	4129	4305	4441	4577	4713	4849	4985	5121	5257	5391	5391	5391	5391	5391	5391	5391	5391	5391	5391	5391	5391	98856			
OPERATING REVENUE	0	0	0	0	0	5200	6019	6778	7537	8669	8839	9010	9180	9350	9521	9691	9861	10032	10202	10372	10543	10713	10883	11054	11224	11224	11224	11224	11224	11224	11224	11224	11224	11224	11224	11224	11224	11224	240861		
OPERATING EXPENSE	0	0	0	0	0	5011	5129	5421	5539	6551	5313	5342	5583	5612	5358	5387	5416	5405	5433	5462	5491	5520	5549	5578	5607	4913	4913	4913	4913	4913	4913	4913	4913	4913	4913	4913	4913	134274			
PERSONNEL COST	0	0	0	0	0	171	182	194	205	217	218	219	221	222	223	225	226	227	228	230	231	232	234	235	236	236	236	236	236	236	236	236	236	236	236	236	236	236	236	5559	
COST OF SUPPLIES	0	0	0	0	0	842	940	1054	1160	1266	1294	1321	1349	1377	1404	1432	1459	1487	1515	1542	1570	1597	1625	1653	1680	1680	1680	1680	1680	1680	1680	1680	1680	1680	1680	1680	1680	1680	1680	35977	
GENERAL ADMINIST. COST	0	0	0	0	0	101	107	114	121	128	129	130	131	131	132	133	134	134	134	135	136	137	137	138	139	139	139	139	139	139	139	139	139	139	139	139	139	139	139	3270	
TRANSPORT ADMIN. COST	0	0	0	0	0	20	23	25	28	31	31	32	33	34	34	35	36	36	37	38	39	39	40	41	41	41	41	41	41	41	41	41	41	41	41	41	41	41	880		
MAINTENANCE ADMIN. COST	0	0	0	0	0	5	6	6	6	6	6	6	6	6	6	6	6	6	6	6	6	6	6	6	6	6	6	6	6	6	6	6	6	6	6	6	6	6	153		
TRANSPORT COST	0	0	0	0	0	101	114	127	141	154	157	161	164	168	171	175	178	182	186	189	193	196	200	203	207	207	207	207	207	207	207	207	207	207	207	207	207	207	4400		
OPERATING COST	0	0	0	0	0	311	350	389	429	460	470	488	498	508	518	527	537	547	557	567	577	587	597	606	616	616	616	616	616	616	616	616	616	616	616	616	616	616	616	13237	
- ELECTRIC POWER COST	0	0	0	0	0	306	345	383	422	461	470	488	498	499	509	519	520	530	548	557	567	577	587	596	606	606	606	606	606	606	606	606	606	606	606	606	606	606	606	13018	
- OTHER OPERATING COST	0	0	0	0	0	5	5	6	7	7	8	8	8	8	8	9	9	9	9	9	10	10	10	10	10	10	10	10	10	10	10	10	10	10	10	10	10	10	219		
TRACK MAINTENANCE COST	0	0	0	0	0	86	90	110	123	135	139	142	146	149	153	156	160	164	167	171	174	178	181	185	189	189	189	189	189	189	189	189	189	189	189	189	189	189	3948		
ELECTRIC FACILITY MAINT.	0	0	0	0	0	76	87	98	109	120	123	126	129	133	136	139	142	145	149	152	155	158	161	164	168	168	168	168	168	168	168	168	168	168	168	168	168	168	3508		
ROLLING STOCK MAINT.	0	0	0	0	0	143	163	184	204	225	231	237	243	249	255	261	267	273	279	285	291	296	302	308	314	314	314	314	314	314	314	314	314	314	314	314	314	314	6580		
DEPRECIATION	0	0	0	0	0	3998	3998	4173	4173	5068	3801	3801	4014	4014	3731	3731	3731	3698	3698	3698	3698	3698	3698	3698	3698	2997	2997	2997	2997	2997	2997	2997	2997	2997	2997	2997	2997	2997	92738		
SALES TAX ETC.	0	0	0	0	0	169	193	218	242	278	284	289	295	300	306	311	317	322	327	333	338	344	349	355	360	360	360	360	360	360	360	360	360	360	360	360	360	360	7732		
INTEREST	0	0	0	0	0	0	0	0	0	0	0	913	867	820	774	728	682	636	590	544	498	452	406	360	314	268	222	176	130	84	38	2	0	0	0	0	0	10862			
NET PROFIT	0	0	0	0	0	80	697	1139	1756	1839	3242	3378	2389	2571	3037	3219	3401	3498	3669	3859	4048	4238	4431	4624	4817	5010	5203	5396	5589	5782	5975	6168	6361	6554	6747	6940	7133	7326	7519	7712	87893
INVESTMENT TOTAL																																									
FOREIGN TOTAL	3594	14375	21044	34930	37300	4082	6654	13443	4245	4224	0	0	4224	0	0	0	0	0	0	0	0	0	0	0	1282	18180	0	2916	0	4023	176375										
LOCAL TOTAL	0	0	220	5433	29277	2041	0	2365	1573	1871	0	0	1871	0	0	0	0	0	0	0	0	0	0	0	1108	8314	0	1458	0	1782	58047										
LAND ACQUISITION	2002	8009	0	0	0	0	0	0	0	0	0	0	0	0	0	0	0	0	0	0	0	0	0	0	0	0	0	0	0	0	0	0	0	0	0	0	0	10011			
CIVIL WORK	1421	5682	19707	20002	2496	0	6337	8404	1008	0	0	0	0	0	0	0	0	0	0	0	0	0	0	0	0	0	0	0	0	0	0	0	0	0	0	0	0	71217			
MACHINERY	0	0	0	0	0	0	0	0	0	0	0	0	0	0	0	0	0	0	0	0	0	0	0	0	0	0	2152	0	0	0	0	0	0	0	0	0	0	4304			
ELECTRIFICATION	0	0	100	3056	5752	0	0	571	1060	0	0	0	0	0	0	0	0	0	0	0	0	0	0	0	0	0	0	2400	0	0	0	0	0	0	0	0	0	13017			
SIGNALS & TELECOM.	0	0	156	2644	4976	0	0	912	1694	0	0	0	0	0	0	0	0	0	0	0	0	0	0	0	1282	0	0	0	0	0	0	0	0	0	0	0	0	0	13542		
ROLLING STOCK	0	0	0	1405	19305	30888	0	2916	0	4023	0	4023	0	0	0	0	0	0	0	0	0	0	0	0	0	13608	0	2916	0	4023	56107										
EDUCATION & TRAINING ETC.	0	0	0	0	843	0	0	0	201	0	0	0	0	0	0	0	0	0	0	0	0	0	0	0	0	0	0	0	0	0	0	0	0	0	0	0	0	1044			
OTHERS	171	605	1002	1603	1776	194	317	640	202	201	0	0	201	0	0	0	0	0	0	0	0	0	0	0	0	0	0	0	0	0	0	0	0	0	0	0	0	7053			
SALVAGE VALUE (-)	0	0	0	0	0	0	0	0	0	0	0	0	0	0	0	0	0	0	0	0	0	0	0	0	0	0	0	0	0	0	0	0	0	0	0	0	0	65473			
FINANCE PROGRAM																																									
FINANCE IN FOREIGN CCY.																																									
BORROWING	0	0	220	5433	29277	2041	0	2365	1573	1871	0	0	1871	0	0	0	0	0	0	0	0	0	0	0	0	0	0	0	0	0	0	0	0	0	0	0	0	0	44659		
REPAYMENT	0	0	0	0	0	0	0	0	0	0	0	0	1849	1849	1849	1849	1849	2139	2139	2139	2139	2139	2139	2233	2233	2233	2233	2233	2233	2233	2233	2233	2233	2233	2233	2233	2233	37805			
LOAN BALANCE	0	0	228	5661	34937	36978	36978	39344	40917	42788	42788	42810	40961	39112	37263	35414	33275	31136	28996	26857	24717	22484	20252	18019	15786	13553	11320	9087	6854	4621	2388	213	0	0	0	0	10962				
INTEREST	0	0	0	0	0	0	0	0	0	0	0	913	867	820	774	728	682	636	590	544	498	452	406	360	314	268	222	176	130	84	38	2	0	0	0	0	10862				
INT. DURING CONSTRUCTION	0	0	0	0	0	0	0	0	0	0	0	0	0	0	0	0	0	0	0	0	0	0	0	0	0	0	0	0	0	0	0	0	0	0	0	0	0	0			
FINANCE IN LOCAL CURRENCY																																									
EQUITY CONTRIBUTION	3594	14375	20816	29497	8023	2041	6654	11078	2671	2353	0	0	2353	0	0	0	0	0	0	0	0	0	0	0	0	0	0	0	0	0	0	0	0	0	0	0	0	0	103457		
EQUITY BALANCE	3594	17969	38786	68283	76307	78348	85002	96000	98751	101104	101104	103457	103457	103457	103457	103457	103457	103457	103457	103457	103457	103457	103457	103457	103457	103457	103457	103457	103457	103457	103457	103457	103457	103457	103457	103457	103457	103457	103457		
CASH FLOW STATEMENT																																									
NET CASH FLOW	0	0	0	0	0	4079	4695	5312	5929	6908	7044	7180	4554	4736	4918	5100	5283	5031	5220	5418																					

FINANCIAL ANALYSIS FOR THE TIANJIN - TANGGU RAILWAY PROJECT

付表15-3-6 感度分析ケース5

(UNIT : 10000 YUAN)

	1991	1992	1993	1994	1995	1996	1997	1998	1999	2000	2001	2002	2003	2004	2005	2006	2007	2008	2009	2010	2011	2012	2013	2014	2015	2016	2017	2018	2019	2020	2021	2022	TOTAL
10000 PERSON-KM PER YEAR	0	0	0	0	0	94607	109345	122003	135661	150042	159100	182175	185241	168307	171373	174440	177506	180572	183638	186704	189771	192837	195903	198969	202035	202035	202035	202035	202035	202035	435404		
PROFIT & LOSS STATEMENT																																	
OPERATING PROFIT	0	0	0	0	0	-788	-215	-20	523	366	1957	2076	1993	2103	2554	2673	2793	2953	3072	3192	3311	3431	3550	3669	3789	4511	4511	4511	4511	4511	4511	65533	
OPERATING REVENUE	0	0	0	0	0	4734	5417	6100	6783	7466	7955	8109	8262	8415	8569	8722	8875	9029	9182	9335	9489	9642	9795	9948	10102	10102	10102	10102	10102	10102	216775		
OPERATING EXPENSE	0	0	0	0	0	5515	5632	5925	6042	7100	5743	5772	6013	6042	5740	5769	5797	5786	5815	5844	5873	5902	5931	5960	5989	5267	5267	5267	5267	5267	5267	144609	
PERSONNEL COST	0	0	0	0	0	171	182	194	205	217	218	219	221	222	223	225	226	227	228	230	231	232	234	235	236	236	236	236	236	236	236	5559	
COST OF SUPPLIES	0	0	0	0	0	842	948	1054	1160	1266	1294	1321	1349	1377	1404	1432	1459	1487	1515	1542	1570	1597	1625	1653	1680	1680	1680	1680	1680	1680	1680	35977	
GENERAL ADMINIST. COST	0	0	0	0	0	101	107	114	121	128	128	129	130	131	132	133	134	134	135	136	137	137	138	139	139	139	139	139	139	139	139	139	3278
TRANSPORT ADMIN. COST	0	0	0	0	0	20	23	25	29	31	31	32	33	34	34	35	36	36	37	38	39	39	40	41	41	41	41	41	41	41	41	900	
MAINTENANCE ADMIN. COST	0	0	0	0	0	5	6	6	6	6	6	6	6	6	6	6	6	6	6	6	6	6	6	6	6	6	6	6	6	6	6	153	
TRANSPORT COST	0	0	0	0	0	101	114	127	141	154	157	161	164	168	171	175	178	182	186	189	193	196	200	203	207	207	207	207	207	207	207	4408	
OPERATING COST	0	0	0	0	0	311	350	389	429	468	478	488	498	508	518	527	537	547	557	567	577	587	597	606	616	616	616	616	616	616	616	13237	
- ELECTRIC POWER COST	0	0	0	0	0	306	345	383	422	461	470	480	490	499	509	519	528	536	548	557	567	577	587	596	606	606	606	606	606	606	606	13818	
- OTHER OPERATING COST	0	0	0	0	0	5	5	8	7	7	8	8	8	8	8	8	9	9	9	9	9	10	10	10	10	10	10	10	10	10	10	219	
TRACK MAINTENANCE COST	0	0	0	0	0	86	98	110	123	135	139	142	146	149	153	156	160	164	167	171	174	178	181	185	189	189	189	189	189	189	189	3948	
ELECTRIC FACILITY MAINT.	0	0	0	0	0	78	87	98	109	120	123	126	129	133	138	139	142	145	149	152	155	158	161	164	168	168	168	168	168	168	168	3589	
ROLLING STOCK MAINT.	0	0	0	0	0	143	163	184	204	225	231	237	243	249	255	261	267	273	279	285	291	296	302	308	314	314	314	314	314	314	314	6588	
DEPRECIATION	0	0	0	0	0	4582	4582	4677	4677	5703	4232	4232	4444	4444	4112	4112	4112	4072	4072	4072	4072	4072	4072	4072	4072	3350	3350	3350	3350	3350	3350	183073	
SALES TAX ETC.	0	0	0	0	0	0	0	196	210	250	255	260	265	270	275	280	285	290	295	300	305	310	314	319	324	324	324	324	324	324	324	6633	
INTEREST	0	0	0	0	0	0	0	0	0	0	0	978	928	879	829	780	805	828	771	713	658	645	585	525	466	406	346	287	227	11733			
NET PROFIT	0	0	0	0	0	-788	-215	-20	523	366	1957	2076	1993	2103	2554	2673	2793	2953	3072	3192	3311	3431	3550	3669	3789	4511	4511	4511	4511	4511	4511	53800	
INVESTMENT TOTAL																																	
FOREIGN TOTAL	0	0	273	6207	31078	2041	0	2532	1888	1871	0	0	1871	0	0	0	0	0	0	0	0	0	0	0	0	0	0	0	0	0	0	0	0
LOCAL TOTAL	4313	17251	24980	35397	9628	2041	7985	12987	3286	2353	0	0	2353	0	0	0	0	0	0	0	0	0	0	0	0	0	0	0	0	0	0	0	0
LAND ACQUISITION	2483	9610	0	0	0	0	0	0	0	0	0	0	0	0	0	0	0	0	0	0	0	0	0	0	0	0	0	0	0	0	0	0	12813
CIVIL WORK	1705	6819	23648	31299	2995	0	7605	18095	1306	0	0	0	0	0	0	0	0	0	0	0	0	0	0	0	0	0	0	0	0	0	0	0	85468
MACHINERY	0	0	0	0	2582	0	0	0	0	0	0	0	0	0	0	0	0	0	0	0	0	0	0	0	0	0	0	0	0	0	0	0	5165
ELECTRIFICATION	0	0	216	3667	8902	0	0	685	1272	0	0	0	0	0	0	0	0	0	0	0	0	0	0	0	0	0	0	0	0	0	0	0	15821
SIGNALS & TELECOM.	0	0	187	3172	5972	0	0	1095	2033	0	0	0	0	0	0	0	0	0	0	0	0	0	0	0	0	0	0	0	0	0	0	0	18258
ROLLING STOCK	0	0	0	1485	19385	3889	0	2916	0	4023	0	0	4023	0	0	0	0	0	0	0	0	0	0	0	0	0	0	0	0	0	0	0	56187
EDUCATION & TRAINING ETC.	0	0	0	0	1012	0	0	0	241	0	0	0	0	0	0	0	0	0	0	0	0	0	0	0	0	0	0	0	0	0	0	0	1253
OTHERS	205	821	1283	1981	1938	194	380	739	243	201	0	0	201	0	0	0	0	0	0	0	0	0	0	0	0	0	0	0	0	0	0	0	8187
SALVAGE VALUE (-)	0	0	0	0	0	0	0	0	0	0	0	0	0	0	0	0	0	0	0	0	0	0	0	0	0	0	0	0	0	0	0	0	75186
FINANCE PROGRAM																																	
FINANCE IN FOREIGN CCY.																																	
BORROWING	0	0	273	6207	31078	2041	0	2532	1888	1871	0	0	1871	0	0	0	0	0	0	0	0	0	0	0	0	0	0	0	0	0	0	0	47762
REPAYMENT	0	0	0	0	0	0	0	0	0	0	0	0	1980	1980	1980	1980	1980	2295	2295	2295	2295	2295	2388	2388	2388	2388	2388	2388	2388	2388	2388	2388	48478
LOAN BALANCE	0	0	273	6481	37559	39800	39800	42132	44020	45891	45891	45891	45782	43882	41822	39842	37862	35568	33273	30978	28684	26389	24001	21613	19225	16837	14449	12081	9673	7285	0	0	
INTEREST	0	0	0	0	0	0	0	0	0	0	0	0	978	928	879	829	780	805	828	771	713	658	645	585	525	466	406	346	287	227	11733		
INT. DURING CONSTRUCTION	0	0	0	0	0	0	0	0	0	0	0	0	0	0	0	0	0	0	0	0	0	0	0	0	0	0	0	0	0	0	0	0	0
FINANCE IN LOCAL CURRENCY																																	
EQUITY CONTRIBUTION	4313	17251	24980	35397	9628	2041	7985	12987	3286	2353	0	0	2353	0	0	0	0	0	0	0	0	0	0	0	0	0	0	0	0	0	0	0	122493
EQUITY BALANCE	4313	21563	46543	81940	91568	93609	101594	114581	117787	120140	120140	122493	122493	122493	122493	122493	122493	122493	122493	122493	122493	122493	122493	122493	122493	122493	122493	122493	122493	122493	122493	122493	
CASH FLOW STATEMENT																																	
NET CASH FLOW	0	0	0	0	0	3721	4287	4656	5288	6089	6188	6388	3470	3639	3888	3978	4145	3845	4021	4198	2121	4552	4589	4768	3418	-14863	5067	2211	5186	76409	161781		
CUMULATIVE NET CASH FLOW	0	0	0	0	0	3721	8008	12665	17864	23933	30121	36429	39899	43537	47345	51321	55487	59311	63233	67531	69652	74204	78793	83561	86971	72908	77975	88186	85372	161781			
CASH IN	4313	17251	25253	41604	40706	7804	12272	20178	10294	10293	6188	6388	10851	6547	6666	8786	6985	7025	7144	7264	7383	7502	7622	7741	7861	7861	7861	7861	7861	7861	7861	338862	
OPERATING PROFIT	0	0	0	0	0	-788	-215	-20	523	366	1957	2076	1993	2103	2554	2673	2793	2953	3072	3192	3311	3431	3550	3669	3789	4511	4511	4511	4511	4511	4511	65533	
DEPRECIATION	0	0	0	0	0	4582	4582	4677	4677	5703	4232	4232	4444	4444	4112	4112	4112	4072	4072	4072	4072	4072	4072	4072	4072	3350	3350	3350	3350	3350	3350	183073	
BORROWING	0	0	273	6207	31078	2041	0	2532	1888	1871	0	0	1871	0	0	0	0	0	0	0	0	0	0	0	0	0	0	0	0	0	0	0	47762
EQUITY CONTRIBUTION	4313	17251	24980	35397	9628	2041	7985	12987	3286	2353	0	0	2353	0																			

	1991	1992	1993	1994	1995	1996	1997	1998	1999	2000	2001	2002	2003	2004	2005	2006	2007	2008	2009	2010	2011	2012	2013	2014	2015	2016	2017	2018	2019	2020	TOTAL	
10000 PERSON-KM PER YEAR	0	0	0	0	0	105209	120393	135559	150735	173390	176767	180134	183601	187008	190415	193822	197229	200635	204042	207449	210856	214263	217670	221077	224484	224484	224484	224484	224484	224484	4817216	
PROFIT & LOSS STATEMENT																																
OPERATING PROFIT	0	0	0	0	0	-3	446	888	1504	1522	3027	3163	3087	3223	3666	3802	3938	4114	4250	4386	4522	4658	4794	4930	5066	5174	5174	5174	5174	5174	93857	
OPERATING REVENUE	0	0	0	0	0	5268	6019	6778	7537	8669	8839	9010	9180	9350	9521	9691	9861	10032	10202	10372	10543	10713	10883	11054	11224	11224	11224	11224	11224	11224	240861	
OPERATING EXPENSE	0	0	0	0	0	5263	5380	5673	5790	6868	5528	5557	5798	5827	5549	5578	5607	5595	5624	5653	5682	5711	5740	5769	5798	5827	5856	5885	5914	5943	5972	139441
PERSONNEL COST	0	0	0	0	0	171	182	194	205	217	218	219	221	222	223	225	226	227	228	230	231	232	234	235	236	236	236	236	236	236	236	5559
COST OF SUPPLIES	0	0	0	0	0	842	948	1054	1160	1266	1294	1321	1349	1377	1404	1432	1459	1487	1515	1542	1570	1597	1625	1653	1680	1680	1680	1680	1680	1680	1680	35977
GENERAL ADMINIST. COST	0	0	0	0	0	101	107	114	121	128	128	129	130	131	131	132	133	134	134	135	136	137	137	138	139	139	139	139	139	139	139	3270
TRANSPORT ADMIN. COST	0	0	0	0	0	20	23	25	28	31	31	32	33	34	34	35	36	36	37	38	39	39	40	41	41	41	41	41	41	41	41	880
MAINTENANCE ADMIN. COST	0	0	0	0	0	5	6	6	6	6	6	6	6	6	6	6	6	6	6	6	6	6	6	6	6	6	6	6	6	6	6	153
TRANSPORT COST	0	0	0	0	0	101	114	127	141	154	157	161	164	168	171	175	178	182	186	189	193	196	200	203	207	207	207	207	207	207	4480	
OPERATING COST	0	0	0	0	0	311	350	389	429	468	478	489	498	508	518	527	537	547	557	567	577	587	597	606	616	616	616	616	616	616	616	13237
- ELECTRIC POWER COST	0	0	0	0	0	306	345	383	422	461	470	480	490	499	509	519	528	538	548	557	567	577	587	596	606	606	606	606	606	606	606	13018
- OTHER OPERATING COST	0	0	0	0	0	5	5	6	7	7	8	8	8	8	8	8	8	8	8	8	8	9	9	10	10	10	10	10	10	10	10	219
TRACK MAINTENANCE COST	0	0	0	0	0	86	98	110	123	135	139	142	146	149	153	156	160	164	167	171	174	178	181	185	189	189	189	189	189	189	3948	
ELECTRIC FACILITY MAINT.	0	0	0	0	0	76	87	98	109	120	123	126	129	133	136	139	142	145	149	152	155	158	161	164	168	168	168	168	168	168	3509	
ROLLING STOCK MAINT.	0	0	0	0	0	143	163	184	204	225	231	237	243	249	255	261	267	273	279	285	291	296	302	308	314	314	314	314	314	314	6580	
DEPRECIATION	0	0	0	0	0	4250	4250	4425	4425	5385	4016	4016	4229	4229	3921	3921	3921	3881	3881	3881	3881	3881	3881	3881	3881	3881	3881	3881	3881	3881	7563	
SALES TAX ETC.	0	0	0	0	0	193	218	242	278	284	289	295	300	306	311	317	322	327	333	338	344	349	355	360	360	360	360	360	360	360	7563	
INTEREST	0	0	0	0	0	985	985	1046	1089	1136	1136	1136	1170	1121	1072	1023	973	922	866	809	752	695	638	579	519	460	401	342	283	224	20361	
NET PROFIT	0	0	0	0	0	-987	-539	-158	415	386	1891	2827	1917	2102	2594	2780	2965	3192	3385	3578	3770	3963	4157	4352	4547	5314	5373	5432	5491	5550	73495	
INVESTMENT TOTAL																																
FOREIGN TOTAL	0	0	251	5820	38177	2041	0	2449	1731	1871	0	0	1871	0	0	0	0	0	0	0	0	0	0	0	1219	8485	0	1458	0	1782	60813	
LOCAL TOTAL	3953	15813	22898	32447	8826	2041	7319	12033	2939	2353	0	0	2353	0	0	0	0	0	0	0	0	0	0	0	191	10150	0	1458	0	2241	127403	
LAND ACQUISITION	2282	8810	0	0	0	0	0	0	0	0	0	0	0	0	0	0	0	0	0	0	0	0	0	0	0	0	0	0	0	0	11012	
CIVIL WORK	1563	6250	21678	28691	2745	0	6971	9244	1197	0	0	0	0	0	0	0	0	0	0	0	0	0	0	0	0	0	0	0	0	0	78339	
MACHINERY	0	0	0	0	0	0	0	0	0	0	0	0	0	0	0	0	0	0	0	0	0	0	0	0	0	0	0	0	0	0	4734	
ELECTRIFICATION	0	0	198	3361	6327	0	0	628	1166	0	0	0	0	0	0	0	0	0	0	0	0	0	0	0	0	0	0	0	0	0	14319	
SIGNALS & TELECON.	0	0	171	2908	5474	0	0	1004	1863	0	0	0	0	0	0	0	0	0	0	0	0	0	0	0	0	0	0	0	0	0	14896	
ROLLING STOCK	0	0	0	1485	19305	3888	0	2916	0	4023	0	0	4023	0	0	0	0	0	0	0	0	0	0	0	0	13608	0	2916	0	4023	56187	
EDUCATION & TRAINING ETC.	0	0	0	0	927	0	0	0	221	0	0	0	0	0	0	0	0	0	0	0	0	0	0	0	0	0	0	0	0	0	1148	
OTHERS	188	753	1102	1822	1857	194	349	698	222	201	0	0	201	0	0	0	0	0	0	0	0	0	0	0	0	0	0	0	0	0	7580	
SALVAGE VALUE (-)	0	0	0	0	0	0	0	0	0	0	0	0	0	0	0	0	0	0	0	0	0	0	0	0	0	0	0	0	0	0	70330	
FINANCE PROGRAM																																
FINANCE IN FOREIGN CCY.																																
BORROWING	0	0	257	5976	31111	2041	0	2449	1731	1871	0	0	1871	0	0	0	0	0	0	0	0	0	0	0	0	0	0	0	0	0	47306	
REPAYMENT	0	0	0	0	0	0	0	0	0	0	0	0	1969	1969	1969	1969	1969	2272	2272	2272	2272	2272	2365	2365	2365	2365	2365	2365	2365	2365	40128	
LOAN BALANCE	0	0	257	6233	37344	39385	39385	41834	43564	45435	45435	45337	43368	41399	39422	37460	35188	32917	30645	28373	26101	23736	21371	19005	16648	14275	11989	9544	7179	0		
INTEREST	0	0	0	0	0	985	985	1046	1089	1136	1136	1170	1121	1072	1023	973	922	866	809	752	695	638	579	519	460	401	342	283	224	20361		
INT. DURING CONSTRUCTION	0	0	6	156	934	0	0	0	0	0	0	0	0	0	0	0	0	0	0	0	0	0	0	0	0	0	0	0	0	0	1096	
FINANCE IN LOCAL CURRENCY																																
EQUITY CONTRIBUTION	3953	15813	22898	32447	8826	2041	7319	12033	2939	2353	0	0	2353	0	0	0	0	0	0	0	0	0	0	0	0	0	0	0	0	0	112975	
EQUITY BALANCE	3953	19766	42664	75111	83937	85978	93298	105331	108269	110622	110622	112975	112975	112975	112975	112975	112975	112975	112975	112975	112975	112975	112975	112975	112975	112975	112975	112975	112975	112975	112975	
CASH FLOW STATEMENT																																
NET CASH FLOW	0	0	0	0	0	3263	3711	4267	4840	5772	5908	6044	4176	4361	4547	4732	4917	4801	4994	5187	5373	5573	5672	5867	4653	-12493	6181	3324	6299	72665	172574	
CUMULATIVE NET CASH FLOW	0	0	0	0	0	3263	6974	11240	16081	21852	27760	33804	37988	42342	46888	51620	56537	61338	66332	71519	74633	80406	86078	91945	96598	84105	90286	93610	99989	172574		
CASH IN	3953	15813	23155	38423	39937	8330	12015	19794	18599	11132	7844	7180	11540	7452	7588	7724	7860	7996	8132	8267	8403	8539	8675	8811	8947	8947	8947	8947	8947	8947	352044	
OPERATING PROFIT	0	0	0	0	0	-3	446	888	1504	1522	3027	3163	3087	3223	3666	3802	3938	4114	4250	4386	4522	4658	4794	4930	5066	5174	5174	5174	5174	93857		
DEPRECIATION	0	0	0	0	0	4250	4250	4425	4425	5385	4016	4016	4229	4229	3921	3921	3921	3881	3881	3881	3881	3881	3881	3881	3881	3881	3881	3881	3881	3881	7563	
BORROWING	0	0	257	5976	31111	2041	0	2449	1731	1871	0	0	1871	0	0	0	0	0	0	0	0	0	0	0	0	0	0	0	0	0	47306	
EQUITY CONTRIBUTION	3953	15813	22898	32447	8826	2041	7319	12033	2939	2353	0	0	2353	0	0	0	0	0	0	0	0	0	0	0	0	0	0	0	0	0	112975	
CASH OUT	3953	15813	23155	38423	39937	5067	8304	15527	5758	5360	1136	113																				

(UNIT : 10000 YUAN)

	1991	1992	1993	1994	1995	1996	1997	1998	1999	2000	2001	2002	2003	2004	2005	2006	2007	2008	2009	2010	2011	2012	2013	2014	2015	2016	2017	2018	2019	2020	TOTAL	
10000 PERSON-KM PER YEAR	0	0	0	0	0	105208	120303	135559	150735	173380	178787	188194	193881	187808	190415	193822	197229	200635	204042	207449	210856	214263	217670	221077	224484	224484	224484	224484	224484	4817216		
PROFIT & LOSS STATEMENT																																
OPERATING PROFIT	0	0	0	0	0	-3	446	888	1504	1522	3027	3163	3087	3223	3666	3802	3938	4114	4250	4386	4522	4658	4794	4930	5066	5774	5774	5774	5774	5774	93857	
OPERATING REVENUE	0	0	0	0	0	5260	6019	6778	7537	8669	8039	9010	9180	9350	9521	9691	9861	10032	10202	10372	10543	10713	10883	11054	11224	11224	11224	11224	11224	240861		
OPERATING EXPENSE	0	0	0	0	0	5263	5380	5873	5790	6868	5528	5557	5798	5827	5549	5578	5607	5595	5624	5653	5682	5711	5740	5769	5798	5890	5890	5890	5890	5890	139441	
PERSONNEL COST	0	0	0	0	0	171	192	194	205	217	218	219	221	222	223	225	226	227	228	230	231	232	234	235	236	236	236	236	236	236	5559	
COST OF SUPPLIES	0	0	0	0	0	842	948	1054	1160	1266	1294	1321	1349	1377	1404	1432	1459	1487	1515	1542	1570	1597	1625	1653	1680	1680	1680	1680	1680	1680	35977	
GENERAL ADMINIST. COST	0	0	0	0	0	101	107	114	121	128	128	129	130	131	131	132	133	134	134	135	136	137	137	138	139	139	139	139	139	139	3270	
TRANSPORT ADMIN. COST	0	0	0	0	0	20	23	25	28	31	31	32	33	34	34	35	36	36	37	38	39	39	40	41	41	41	41	41	41	41	880	
MAINTENANCE ADMIN. COST	0	0	0	0	0	5	6	6	6	6	6	6	6	6	6	6	6	6	6	6	6	6	6	6	6	6	6	6	6	6	153	
TRANSPORT COST	0	0	0	0	0	101	114	127	141	154	157	161	164	168	171	175	178	182	186	189	193	196	200	203	207	207	207	207	207	207	4400	
OPERATING COST	0	0	0	0	0	311	350	389	429	468	478	488	498	508	518	527	537	547	557	567	577	587	597	606	616	616	616	616	616	616	13237	
- ELECTRIC POWER COST	0	0	0	0	0	306	345	383	422	461	470	480	490	499	509	519	528	538	548	557	567	577	587	596	606	606	606	606	606	606	13018	
- OTHER OPERATING COST	0	0	0	0	0	5	5	6	7	7	8	8	8	8	8	9	9	9	9	9	9	10	10	10	10	10	10	10	10	10	219	
TRACK MAINTENANCE COST	0	0	0	0	0	86	98	110	123	135	139	142	146	149	153	156	160	164	167	171	174	178	181	185	189	189	189	189	189	189	3948	
ELECTRIC FACILITY MAINT.	0	0	0	0	0	76	87	98	109	120	123	126	129	133	138	139	142	145	149	152	155	158	161	164	168	168	168	168	168	168	3589	
ROLLING STOCK MAINT.	0	0	0	0	0	143	163	184	204	225	231	237	243	249	255	261	267	273	279	285	291	296	302	308	314	314	314	314	314	314	6580	
DEPRECIATION	0	0	0	0	0	4250	4250	4425	4425	5385	4016	4016	4229	4229	3921	3921	3921	3881	3881	3881	3881	3881	3881	3881	3881	3881	3881	3881	3881	3881	97986	
SALES TAX ETC.	0	0	0	0	0	0	193	218	242	278	284	289	295	300	308	311	317	322	327	333	338	344	349	355	360	360	360	360	360	360	7563	
INTEREST	0	0	0	0	0	0	0	0	0	2014	1912	1818	1708	1686	1584	1899	1772	1645	1518	1391	1264	1218	1079	948	817	686	555	424	294	26856		
NET PROFIT	0	0	0	0	0	-3	446	888	1504	1522	1813	1251	1277	1515	2060	2298	2039	2342	2605	2868	3132	3395	3585	3852	4118	4957	5088	5219	5349	5480	87801	
INVESTMENT TOTAL																																
	3953	15813	23149	38267	39003	4082	7319	14481	4669	4224	0	0	4224	0	0	0	0	0	0	0	0	0	0	0	1410	18615	0	2916	0	4023	188215	
FOREIGN TOTAL	0	0	251	5828	38177	2041	0	2449	1731	1871	0	0	1871	0	0	0	0	0	0	0	0	0	0	0	1219	8465	0	1458	0	1782	60813	
LOCAL TOTAL	3953	15813	22898	32447	8826	2841	7319	12033	2939	2353	0	0	2353	0	0	0	0	0	0	0	0	0	0	0	191	10150	0	1458	0	2241	127403	
LAND ACQUISITION	2202	8810	0	0	0	0	0	0	0	0	0	0	0	0	0	0	0	0	0	0	0	0	0	0	0	0	0	0	0	0	11012	
CIVIL WORK	1563	6258	21678	28691	2745	0	6971	9244	1197	0	0	0	0	0	0	0	0	0	0	0	0	0	0	0	0	0	0	0	0	0	78339	
MACHINERY	0	0	0	0	0	0	0	0	0	0	0	0	0	0	0	0	0	0	0	0	0	0	0	0	0	0	0	0	0	0	4734	
ELECTRIFICATION	0	0	198	3361	6327	0	0	829	1166	0	0	0	0	0	0	0	0	0	0	0	0	0	0	0	0	0	0	0	0	0	14319	
SIGNALS & TELECOM.	0	0	171	2908	5474	0	0	1904	1863	0	0	0	0	0	0	0	0	0	0	0	0	0	0	0	0	0	0	0	0	0	14896	
ROLLING STOCK	0	0	0	1485	19385	3888	0	2916	0	4823	0	0	4823	0	0	0	0	0	0	0	0	0	0	0	0	0	0	0	0	0	56187	
EDUCATION & TRAINING ETC.	0	0	0	0	927	0	0	0	221	0	0	0	0	0	0	0	0	0	0	0	0	0	0	0	0	0	0	0	0	0	1148	
OTHERS	188	753	1182	1822	1857	194	349	690	222	281	0	0	281	0	0	0	0	0	0	0	0	0	0	0	0	0	0	0	0	0	7588	
SALVAGE VALUE (-)	0	0	0	0	0	0	0	0	0	0	0	0	0	0	0	0	0	0	0	0	0	0	0	0	0	0	0	0	0	0	78330	78330
FINANCE PROGRAM																																
FINANCE IN FOREIGN CCY.																																
BORROWING	2629	10517	14328	24367	26879	2858	4608	9439	3140	2957	0	0	2957	0	0	0	0	0	0	0	0	0	0	0	0	0	0	0	0	0	184679	
REPAYMENT	0	0	0	0	0	0	0	0	0	0	4878	4079	4079	4079	4079	4079	4079	5086	5086	5086	5086	5086	5086	5234	5234	5234	5234	5234	5234	5234	96861	
LOAN BALANCE	2629	13147	27474	51841	78720	81578	86186	95625	98765	181722	97643	93564	92442	88363	84284	88205	75119	70833	64947	59861	54775	49689	44455	39221	33987	28753	23519	18285	13851	7817		
INTEREST	0	0	0	0	0	0	0	0	0	0	2014	1912	1818	1708	1686	1584	1899	1772	1645	1518	1391	1264	1218	1079	948	817	686	555	424	294	26856	
INT. DURING CONSTRUCTION	0	0	0	0	0	0	0	0	0	0	0	0	0	0	0	0	0	0	0	0	0	0	0	0	0	0	0	0	0	0	0	0
FINANCE IN LOCAL CURRENCY																																
EQUITY CONTRIBUTION	1324	5296	8021	13908	12124	1225	2712	5042	1529	1267	0	0	1267	0	0	0	0	0	0	0	0	0	0	0	0	0	0	0	0	0	54507	
EQUITY BALANCE	1324	6628	15441	29341	41465	42698	45481	50444	51973	53248	53248	54587	54587	54587	54587	54587	54587	54587	54587	54587	54587	54587	54587	54587	54587	54587	54587	54587	54587	54587	54587	
CASH FLOW STATEMENT																																
NET CASH FLOW	0	0	0	0	0	4247	4695	5312	5929	6908	951	1189	1427	1665	1903	2141	874	1137	1400	1663	-148	2190	2232	2499	1356	-15718	3827	242	3289	69726	110145	
CUMULATIVE NET CASH FLOW	0	0	0	0	0	4247	8943	14255	20185	27092	28043	29232	38659	32324	34227	36367	37241	38378	39779	41442	41303	43492	45724	48223	49579	33868	36888	37138	40419	110145		
CASH IN	3953	15813	23149	38267	39003	8338	12015	19794	10599	11132	7844	7188	11548	7452	7588	7724	7860	7996	8132	8267	8403	8539	8675	8811	8947	8947	8947	8947	8947	8947	350948	
OPERATING PROFIT	0	0	0	0	0	-3	446	888	1504	1522	3027	3163	3087	3223	3666	3802	3938	4114	4250	4386	4522	4658	4794	4930	5066	5774	5774	5774	5774	5774	93857	
DEPRECIATION	0	0	0	0	0	4250	4250	4425	4425	5385	4016	4016	4229	4229	3921	3921	3921	3881	3881	3881	3881	3881	3881	3881	3881	3881	3881	3881	3881	3881	97986	
BORROWING	2629	10517	14328	24367	26879	2858	4608	9439	3140	2957	0	0	2957	0	0	0	0	0	0	0	0	0	0	0	0	0	0	0	0	0	184679	
EQUITY CONTRIBUTION	1324	5296	8021	13908	12124	1225	2712	5042	1529	1267	0	0	1267	0	0	0	0															

JICA