

The embankment work of roads shall maintain the adequate water content in the materials so as to keep the workability and the compaction effect.

The temporary drainage may be needed in order to not impound the rain water into the on-going work site, especially in the farm pond area.

The irrigation and drainage canal works consist of 2 major works of earth excavations and concretings. The excavation works will be carried out mainly by manpower because of small sectional areas for the excavation. While, the concreting will be made by a small mixer at the field, and the handling and placing will be carried out by using carts.

6.2 Implementation Time Schedule

Period of the dry season is from April to September at the project site. In order to begin land levelling works from April, procedures of contract and preparatory/temporary works are expected to be finished until the end of March during the rainy season. Implementation schedule of the works is proposed, keeping the above in mind, in this section described as follows:

The project implementation will start on February 10, 1991 and the construction works will enter into a contract with the contractor on the end of February. An actual construction period will be 175 days from March 10 to August 31.

A supervising expert dispatched by the JICA will engage his services for the project for 203 days from February 10 to August 31.

Detailed time schedules are shown in the following table:

IMPLEMENTATION TIME SCHEDULE

Work Items	1991							Note
	Feb.	Mar.	Apr.	May.	Jun.	Jul.	Aug.	
I. Preparatory Works								
1.1 Contracts	■							
Scheduled Date of Contract		△						
II. Construction Works								157 days
1. Preparatory/Temporary Works		△						
2. Land Levelling			■	■	■			
3. Link Road				■	■	■		
3.1 Sub-base				▨	▨			
3.2 Pavings						▨	▨	
4. Irrigation/Drainage System				■	■	■	■	
4.1 Farm Pond				▨	▨			
4.2 Irrigation Canal					▨	▨		
4.3 Drainage Canal					▨	▨	▨	
5. Soil Conservation Test Field					■	■	■	
6. Irrigation Test Field						■	■	
6.1 Paddy Field						▨	▨	
6.2 Upland						▨	▨	
7. Tractor Test Field					■	■		
8. Tractor Test Road				■		■		
8.1 Sub-base				▨				
8.1 Pavings						▨		
9. Final Inspections/Clearings							■	
III. Supervising Expert	■	■	■	■	■	■	■	203 days

APPENDIXES

Appendix A. Contract Documents

1. Contract Agreement (Draft)
2. Conditions of Contract (Draft)
3. General Specification (Draft)
4. Technical Specification (Draft)
5. Drawings

1. Contract Agreement (Draft)

CONTRACT AGREEMENT
FOR
CONSTRUCTION OF MODEL INFRASTRUCTURE IMPROVEMENT WORKS
ON
THE ACADEMIC DEVELOPMENT OF THE
GRADUATE PROGRAM AT THE FACULTY OF
AGRICULTURAL ENGINEERING
AND TECHNOLOGY,
INSTITUT PERTANIAN BOGOR
IN
INDONESIA

INDONESIA OFFICE
JAPAN INTERNATIONAL COOPERATION AGENCY

CONTRACT AGREEMENT

The Contract Agreement (hereinafter, together with all the Appendices attached hereto and forming an integral part hereof, referred to "the Agreement") executed on the (day) of (month) , 1991 at the JICA INDONESIA Office between Japan International Cooperation Agency, INDONESIA Office by Mr. Yasuo KITANO titled Resident Representative as its authorized representative of JICA INDONESIA Office, hereinafter referred to as "the JICA" of one part, and (Company's name) (address) represented by Mr. (Representative's name) , hereinafter referred to as "the Contractor" of the other part.

Both parties mutually agree with under the terms of this Contract as follows:

Article 1 Purpose of Agreement and Contract Price

The JICA agrees to employ the Contractor and the Contractor agrees to perform the Works for the construction of the Model Infrastructure Improvement Works for the Academic Development of the Graduate Program at the Faculty of Agricultural Engineering and Technology, Institut Pertanian Bogor in the Republic of Indonesia, hereinafter referred to as "the Works", for the total amount of _____ Indonesia Rupiahs (in letter _____ thousand Indonesia Rupiahs), hereinafter referred to as "the Contract Price".

Article 2 Scope of Works

The Contractor shall:

- (1) perform the Work under the supervision of the JICA's Expert authorized to act on behalf of the JICA, hereinafter referred to as "the Expert", in accordance with this Agreement, Conditions of Contract, General Specification, Technical Specification and Drawings;
- (2) prepare working drawings, shop drawings, construction schedule, other technical documents and reports required by the Expert;

- (3) be responsible for construction means, methods, techniques sequence and procedure, and for safety precautions and programs in connection with the Works, which shall all be in accordance with the current relevant regulations and laws of the Republic of Indonesia, and also for his failure to carry out the Works;
- (4) carry out any modification, amendment, change of alteration to the Works as inspected by the Expert to comply with any current regulations or laws in force in Indonesia without any cost to the JICA.

Article 3 Contract Documents

The following documents shall be deemed to form and to read as a part of this Agreement, namely:

- (1) Drawings
- (2) Conditions of Contract
- (3) General Specification
- (4) Technical Specification
- (5) Bill of Quantities

Article 4 Payment

The JICA agrees to effect payments for the Works to the Contractor in the following manner:

- (1) Advance Payment, to be effected upon the bringing of equipment and materials required for the Works and properly stored at the job site by the Contractor and of value estimated by the Expert.

_____ Indonesia Rupiahs () which corresponds to Forty (40) per cent of the Contract Price shall be paid upon signing of this Contract.

- (2) Final Payment, to be effected upon the satisfactory completion of the Works by the Contractor and accepted by the Expert.

The remainder of _____ Indonesia Rupiahs () which corresponds to Sixty (60) per cent of the Contract Price, shall be paid after issue of the Final Certificate by the JICA for payment to the Contractor. Payment under (2) shall be effected within ten (10) days after the respective acceptance of the Works by the Expert.

In cases of the payment being delayed owing to a cause or causes attributable to the Employer, the Contractor may request the Employer to pay interest on arrears of payment at one percent (1%) over the bank rate.

Article 5 Time of Commencement and Completion

The Contractor agrees to commence the Works at the site within ten (10) days from the date of signing of this Contract (commencement date) and the Contractor agrees to satisfactorily complete the Works within () days (completion time) from the date hereof which will become due on (completion date).

Article 6 Delays

If the Contractor fails to commence the Works by the above commencement date, or should in the course of the construction any event occur which may reasonably cause the JICA to believe that the Contractor will not be able to complete the Works on the completion date, or should the Contractor fail to complete the works by the completion date, or should the Contractor fail to meet any of the Contract requirements, the JICA shall have the right to terminate this Contract by giving written notice to the Contractor.

However, in case that the Contractor fails to complete the Works by the completion date, or to meet any of the Contract requirements, the Contractor shall inform the JICA of this by a letter as soon as possible, and if the Expert judges that the Contractor has the ability for completion of the Works within reasonably extended period, the Contractor may be permitted by the JICA to continue the Works beyond the completion date but within the extended time.

In this case, the sum referred to in Article 8 will not be collected.

Article 7 Compensation

If the JICA or a third Party sustains any losses as direct or indirect damages caused by the Contractor's failure, the Contractor shall compensate the JICA or a third Party for such losses. Both the JICA and the Contractor agree that it is essential to complete the Work in time.

Article 8 The JICA Right for Default

The JICA has the sole and absolute right to decide whether to terminate the Contract, to claim the compensation for the damage as stated in Article 7. The expense due to the JICA exercising its right under this article shall be retained and deducted from any money due to the Contractor but yet unpaid. If the total amount of the loss is larger than the above mentioned, the Contractor agrees that the JICA has the right to retain the construction equipment, materials and supplies etc. of the Contractor and demand payment of the balance from such equipment etc. or proceeds of sale thereof.

In cases where the Contractor fails to fulfil his obligations under this Contract, the JICA may rescind the whole or part of the Contract. In such a case, the JICA may collect from the Contractor a sum as a penalty of ten percent (10%) of the amount which is equivalent to the rescinded. In cases where the damages caused on the JICA, on account of the non-fulfilment of Contract by the Contractor, exceed the sum referred to in the preceding paragraph, the JICA may further demand the Contractor to pay the excess.

In cases other than provided for in the said clause where the Contractor fails to fulfil his obligations, or in cases where the fulfilment of obligations by the Contractor is regarded to be difficult, the JICA may ask a third Party to fulfil, at the cost of the Contractor, the whole or part of the obligations of the Contractor. Even if liability of the Contractor exceeds the contract sum referred to in Article 1 in consequent of this, the Contractor shall not raise any objection to it.

In cases other than provided for in the said clause where the Contractor fails to complete the construction at his own responsibility within the period referred to in Article 5, the Contractor shall be liable, within a period fixed by the JICA, to pay the Employer per week of delay a sum equivalent to 0.1 percent (0.1%) of the contract sum referred to in Article 1.

Article 9 Discrepancies among the Contract Documents and Process of the Works

The Contractor shall carry out the Works in accordance with the Drawings and Specifications referred to in Article 3. If, prior to or during the course of the Works, any discrepancies are found in the Drawings and/or the Technical Specifications etc. attached to this Contract, the Contractor shall follow the ruling given by the Expert at no additional cost to the JICA.

In cases where it is necessary for the Contractor to carry out such work as is not mentioned therein for the purpose of promoting the present construction or for reasons of established practices, the Contractor shall carry out the said work under the direction of the Expert. In cases where the Contractor finds any doubt in the plans of construction, the Contractor shall ask the Expert for the necessary directions before commencing the work on that part for which there exists some doubt.

The Expert must provide such information and details within seven (7) days of the written request from the Contractor.

Article 10 Inspection and Delivery of the Works

The Expert, appointed by the JICA, is entitled to do all things that the JICA may do so. The Expert shall control and supervise the Works and the Contractor shall promptly furnish all necessary facilities for proper inspections of the Works in accordance with the request of the Expert.

At any moment the Expert can request the Contractor to stop the Works, if necessary and the Contractor shall have no claim on the JICA for extension of the completion time due to such suspension of the Works under this Article.

Upon completion of the entire Works, the Contractor shall request the Expert carry out a final inspection, and the Expert shall promptly inspect the Works in the presence of the Contractor.

If the Work fails to pass the inspection, the Contractor shall undertake repair or reconstruction work in accordance with the instruction of the Expert within the time of completion and shall have the said work reinspected by the Expert. After the Expert certifies the Works to have been complete, the Contractor shall hand over the Works immediately to the JICA.

Article 11 Materials

As to materials for the Works, the Contractor shall use only those inspected and approved by the Expert. In cases where any defective work has been done as a result of such use of materials which have not been inspected by the Expert, or of disobedience to the direction of the Expert, the Contractor shall be liable to change the materials or repair the Work at his own responsibility. The Works shall be carried out in accordance with the proper technique, and durability shall be the principal aim as regards to the Works.

Article 12 Workmen

As to the labors, foremen or engineers to be hired by the Contractor for the Works, the Contractor shall assume the responsibility as entrepreneur or employer, as provided for by laws and regulations in the Republic of Indonesia.

Article 13 Project Manager

The Contractor shall appoint a project manager at his own expense for the supervision of the Works performance, who shall be authorized to act on behalf of the Contractor, and the instructions given to him shall be deemed as given to the Contractor. Such project manager shall be a well English speaking person and accepted by the JICA, who shall stay at the job site all the time and shall not leave without obtaining the prior approval of the Expert. If the Contractor replaces the project manager, the Contractor shall obtain the prior approval from the JICA in writing.

Article 14 Replacement of Workmen

The Expert may request the Contractor to remove any of the Contractor's labors, foremen or engineers if it appears to the Expert that such labor, foreman or engineer is incompetent for his job or is not suitable or is not capable of handling his workmen or staff, and the Contractor shall promptly replace any such labor, foreman or engineer. No extra cost or claim for extension of time will be allowed because of such replacement.

Article 15 Sub-Contractor

The Contractor shall not sublet or assign any portion of the Works under his contract without obtaining the prior approval of the JICA who has the sole right to decide which portion of the Works may be sublet or assigned to the Sub-Contractor. However, the Contractor shall be fully responsible for the Works done by the Sub-Contractor.

Article 16 Construction Method and Temporary Works

The construction method including implementation schedule and plan of the temporary works such as installation of temporary facilities, offices, ware houses, construction roads, electric wiring, etc. shall be submitted by the Contractor and approval by the Expert.

Should the cost of the above temporary works be estimated in the unit cost of each work items of Bill of Quantities in this Contract, and the Contractor is not entitled to claim any amount of charges for the temporary works.

Article 17 Change of Construction Drawings and Submission of Necessary Documents

In cases where the JICA feels it is necessary to discontinue the Works owing to unavoidable circumstances, or to alter the plan of construction, the JICA may request the Contractor to calculate, on the basis of the unit prices as detailed in the priced Bill of Quantities, as to increase or decrease in the sum of construction resulting from the suspension or alteration of the Works, and the Contractor shall comply with the request. When the JICA orders such a suspension or alteration, depending on the statement of the above mentioned calculation, the Contractor shall submit a written consent by the date appointed by the JICA.

Where work cannot be properly measured and valued on the basis of the unit price in the Bill of Quantities, the Contractor will be allowed to calculate on the basis of the daywork rates which shall be approved by the JICA before their application.

Article 18 Price Adjustment

In the case of the costs of materials rising sharply as a result of the fluctuation in the market prices due to an unexpected change in the economic conditions, a reasonable adjustment of

the contract sum or the unit prices in the Bill of Quantities will be made through negotiations between the JICA and the Contractor.

In a case where a loss such as may render it unreasonable for the contract sum referred to in Article 1, is inflicted upon the Contractor by virtue of the JICA's failure to provide the information and details referred to in Article 9 or to obtain the necessary approvals under the local bye-laws, then a reasonable adjustment of the above mentioned sum will be made on the basis of the detailed claim submitted by the Contractor.

Article 19 Damage Caused by Natural Calamity, etc.

In cases where serious damages occur in the completed part of the work, or the materials, tools, etc., already carried into the site, the Contractor shall promptly inform the JICA of the circumstances. If such damages are caused by a natural calamity, an earthquake, a flood, a civil war, a war, an epidemic, or a general/trade strike, riot or other unavoidable reasons, for the occurrence of which no responsibility can be attributed to either the JICA or the Contractor, and it is admitted that the Contractor has paid the care of good administrator to avoid the occurrence of such damages, the JICA shall be liable for the amount of the damages which shall be fixed through negotiations between the JICA and the Contractor.

Article 20 Notice

All notices required by this Contract shall be effective only at the time of receipt thereof, and only when received by the parties concerned at the following address:

The JICA INDONESIA OFFICE _____

The Contractor _____

All notices required by the terms of this Contract shall be made in writing in English Language, and delivered by registered mail or hand delivery.

Article 21 Rectification of the Defective Construction

For a further period of one (1) year after satisfactory completion and final acceptance of the Works by the JICA; whether completed by the Contractor or by the new Contractor in case of termination of Contract under Article 5, and damage to the Works which is caused by the Contractor's fault, either because of defective workmanship or the use of inferior materials or any other cause, shall be made good as necessary by the Contractor to the satisfaction of the JICA at no extra cost.

In case of the termination of the Contract, the JICA may decide which part of the Works should come under the Contractor's responsibility, and requests the Contractor to make good of the damaged Works.

Should the Contractor fail to do so within period specified after receipt of written request to do so from the JICA, the JICA shall have the right to employ another Contractor to carry out such work and the Contractor agrees to bear all expenses incurred.

Article 22 Settlement of Disputes

If any dispute or difference of any kind between the JICA or the Expert and the Contractor whatsoever arising out of or relating to the Contract, or the execution of the Works, whether during the progress of the Works or after their completion and whether before or after the termination, abandonment or breach of the Contract, it shall be settled by mutual agreement.

If it should not be possible to reach mutual agreement between the JICA and the Contractor on such dispute, then it shall be referred to an Arbitrator or Arbitrators acceptable to both the JICA and the Contractor, and the decision of this Arbitrator or Arbitrators shall be binding on both the JICA and the Contractor.

This Contract is executed in duplicate of the same tenor, one of the original copy to be kept by the JICA and the other original copy to be kept by the Contractor. Both the JICA and the Contractor have set their signatures and affixed the seals thereto in the presence of the witnesses.

The JICA

Mr.
Resident Representative
INDONESIA OFFICE
Japan International Cooperation Agency

The CONTRACTOR

Date:

2. Conditions of Contract (Draft)

CONDITIONS OF CONTRACT
FOR
CONSTRUCTION OF MODEL INFRASTRUCTURE IMPROVEMENT WORKS
ON
THE ACADEMIC DEVELOPMENT OF THE
GRADUATE PROGRAM AT THE FACULTY OF
AGRICULTURAL ENGINEERING
AND TECHNOLOGY,
INSTITUT PERTANIAN BOGOR
IN
INDONESIA

INDONESIA OFFICE

JAPAN INTERNATIONAL COOPERATION AGENCY

1. Objectives

The JICA, Japan International Cooperation Agency, wants to carry out the Model Infrastructure Improvement Works for the Academic Development of the Graduate Program at the Faculty of Agricultural Engineering and Technology, Institut Pertanian Bogor in the Republic of Indonesia.

2. Work Schedule

The Contractor shall submit to the JICA for this approval of the detailed work schedule for performing the construction works within seven (7) days after signing by both parties of this agreement.

3. Operation of Work

To control the construction works, a project manager belonging to the Contractor is required to stay at the construction office. If the project manager does not stay at the office without appropriate reason, the JICA reserves the right to stop the Works or part of the Works instantly and the Contractor is required to be responsible for any damage from this neglect.

4. Progress Report

Progress reports shall be submitted to the Expert by the Contractor every month. If there is any delay of the Works from agreed schedule, the Contractor shall submit the modified work schedule to the Expert to justify for such a delay so as to achieve the originally set target.

5. Acceptance of Completed Works

Upon receipt of the written request from the Contractor, the Expert will check the Works actually performed in the site. If everything is satisfactorily completed, the JICA will accept that part of the Works within seven (7) days after the receipt of the request. If there are any inconsistency and shortcomings in the Works presented by the Contractor, the JICA will reserve the right not to accept the Works. During the improvement of the Works, it will be regarded that the Works have not been accepted. After completion of the improvement works, the Contractor shall request the Expert to inspect it again. If the improvement works

are satisfactorily completed, the JICA will accept the Works within seven (7) days after the receipt of the request.

However, the acceptance does not necessarily mean the discontinuation of the responsibility of the Contractor for possible damages of that part of the Works. The complete acceptance takes place only when all the Works have been completed and accepted.

6. Increase or Decrease of Unit Price

In the event of remarkable fluctuation in the costs of labor, materials, equipment, etc., the adjustment of unit prices may be made based on the escalation factors through negotiations between the JICA and the Contractor. However, no adjustment will be made in case of the delay of the construction works due to the fault of the Contractor.

7. General Text

The construction works shall be proceeded in accordance with the Drawings and Specifications in every respect. In case, however, the Expert adds to or revises the original Drawings and/or Specifications in order to attain further engineering perfection, the Contractor is required to proceed with the construction in accordance with the added or revised drawings and/or specifications without any objections.

8. Alignment, Levelling and Site-Plan Setting

The Expert is to inform the Contractor of the bench mark which gives the base elevation to be used for the construction. The succeeding steps shall be the duty of the Contractor. The Contractor shall set and determine the alignment and elevation in accordance with the Drawings in the construction area and ask for the inspection of the Expert prior to the commencement of the construction. The Contractor is required to preserve all the pegs that indicate the alignment and elevation in a good condition throughout the construction period. In cases where the Expert requests, the Contractor shall conduct checking survey and submit the results to the Expert as soon as possible.

3. General Specification (Draft)

GENERAL SPECIFICATION
FOR
CONSTRUCTION OF MODEL INFRASTRUCTURE IMPROVEMENT WORKS
ON
THE ACADEMIC DEVELOPMENT OF THE
GRADUATE PROGRAM AT THE FACULTY OF
AGRICULTURAL ENGINEERING
AND TECHNOLOGY,
INSTITUT PERTANIAN BOGOR
IN
INDONESIA

INDONESIA OFFICE

JAPAN INTERNATIONAL COOPERATION AGENCY

1. General Description

In the Academic Development of the Graduate Program, it is urgently necessary to prepare an experimental farm that serve for the activities carried out at the Faculty of Agricultural Engineering and Technology, Institut Pertanian Bogor.

Therefore, the Japan International Cooperation Agency (JICA) intends to construct link road, test fields, irrigation and drainage system, test road and other facilities in the experimental farm under the Model Infrastructure Improvement Works for the Academic Development of the Graduate Program at the Faculty of Agricultural Engineering and Technology, Institut Pertanian Bogor in the Republic of Indonesia.

The Works provided for in this Contract are:

- land levelling
- the installation of the irrigation and drainage system including a farm pond, irrigation canal, drainage canal and the related facilities
- the construction of link road, farm road and tractor test road
- the construction of soil conservation test field, irrigation test field and tractor test field

2. Scope of Contract

- (1) The Contractor shall, except as otherwise provided for in the Contract, furnish all labor, material, Constructional Plant, Temporary Works and other necessities for the construction of the Works. The Contractor shall execute, complete and maintain the Works in strict accordance with the Specifications and Drawings or as directed by the Expert.
- (2) The several documents forming the Contract are to be taken as mutually explanatory of one another, but in case of ambiguities or discrepancies the same shall be explained and adjusted by the Expert, who shall thereupon issue to the Contractor instructions.
- (3) Unless it is legally or physically impossible, the Contractor shall execute and complete the Works and remedy any defects therein in accordance with the Contract to the satisfaction of the Expert. The Contractor shall comply with and adhere strictly to the Contract or not, touching and concerning the Works. And any other incidental works

shall be completed by the Contract under the Expert's instruction even if it is not pointed out in the Specifications.

- (4) The Expert shall have authority to issue to the Contractor, from time to time, such supplemental Drawings and instructions as shall be necessary for the purpose of the proper and adequate execution and completion of the Works and remedying of any defects therein. The Contractor shall carry out and be bound by the same.
- (5) In case that a better measures should be found out in order to execute the Works, the Contractor can plan and submit to the Expert, for approval.
- (6) The Works to be carried out under the Contract will include the followings.
 - (a) The construction and maintenance of any temporary facilities and access roads required by the Contractor for the execution of the permanent works.
 - (b) The construction of link road, test fields, test road, irrigation and drainage system and other related facilities.

- Land levelling	2.5 ha
- Link Road (Asphalt Pave.)	454 m
- Farm Road (Gravel)	100 m
- Farm Pond	1,000 m ³ in Capacity
- Irrigation Canal	96 m
- Drainage Canal	1,571 m
- Soil Conservation Test Field	1,940 m ²
- Irrigation Test Field (Paddy Field)	3,000 m ²
- Irrigation Test Field (Upland)	2,700 m ²
- Tractor Test Field (Upland)	3,010 m ²
- Tractor Test Road (Conc. Pave.)	150 m
- Tractor Test Road (Gravel)	150 m
- Tractor Test Road (Earth)	150 m
- Other Related Facilities (including two pump stations)	

3. Ambiguity of Design, Adverse Physical Obstructions or Conditions

The Contractor shall forthwith give notice to the Expert and take instructions from the Expert in the following cases:

- (1) In case that there are discrepancies of contents among the documents.
- (2) In case that the documents shall not be clear.
- (3) In case that the documents shall not be corresponded to the site.
- (4) In case that during the execution of the Works the Contractor encounters physical obstructions or conditions, other than climatic conditions on the site, which obstructions or conditions is not foreseeable by the experienced contractor.

4. Small Variations

The Expert shall make any variation of the form, quality or quantity of the Works or any part thereof that may, in this opinion, be necessary and for that purpose, or if for any other reason it shall be appreciated, he shall have authority to instruct the Contractor to do and the Contractor shall do any of the following:

- a. increase or decrease the quantity of any work included in the Contract,
- b. change the character or quality or kind of any such work,
- c. change the levels, lines, position, and dimensions of any part of the Work,
- d. change any specified sequence or timing of construction of any part of the Works.

In this case, the Contract cost shall not be changed.

5. Design Changes

The Contractor shall not make any variations without an instruction of the Expert. However, in case that the Contractor should be requested to make any large variation or execute additional work of any kind necessary for the completion of the Works, the Contractor will submit a statement showing the description and quantity of all materials to the Expert for his letter of approval, and then will execute such works.

In case that the Contractor should be instructed on the Site without the letter of approval, the Contractor will deliver to the Expert a priced statement of the labor and materials used within ten (10) days after the Expert's instruction. The unit cost will be the same at the time of the Contract.

6. Setting Out

The Contractor shall be entirely responsible for the accurate setting out of the Works from the information supplied on the Drawings and the instructions given by the Expert.

7. Drawings

The attached drawings accompany and form a part of Specifications. During the progress of the Works, additional drawings will be issued by the Expert as necessity arises to supplement, supersede or further set forth details shown on the Drawings hereto attached and additional drawings shall thereupon become a part of Specifications.

8. Statutory Obligations

The Contractor shall comply with all statutory obligations and the regulations of any Government or local authority, public service or official body relating to the execution of the Works, both on and off the site.

9. Notices, Fees and Charges

The Contractor shall give all notices and pay all fees and charges required by any local authority, public service, statutory or official body.

10. Expenses included in the Contract Cost

The cost of the following works are included in the Contract Cost:

- (1) Expenses for the execution and for the inspection or test of materials
- (2) Expenses for the temporary works
- (3) Expenses for the removal of obstruction
- (4) Expenses for the temporary services

11. Expenses not included in the Contract Cost

The following expenses shall be borne by the JICA.

- (1) Expenses for the removal of large size obstruction which lays under the ground and is not foreseeable.
- (2) Expenses for the handing over ceremony. However, the Contractor shall cooperate to arrange the ceremony with the JICA.

12. Construction Program

Within seven (7) days after the award of the Contract, the Contractor shall submit to the Expert for his approval, a construction program in bar chart form or otherwise, as may be required by the Expert, showing in detail his proposed schedule of operation and providing for the orderly completion of the Work by the dates specified in the Contract. The Expert's estimate of the construction time schedule delivered is to be used only for consideration by the Contractor and does not relieve the Contractor from preparing and submitting his own time bar construction schedule.

The submission to and approval by the Expert of such program shall not relieve the Contractor from any of his duties of responsibilities under the Contract.

13. Patents Rights

The Contractor shall save harmless and indemnify the JICA from and against all claims and proceedings for or on account of infringement of any patent rights, design trademark or name or other protected rights in respect of any Contractor's Equipment, materials or Plant used for or in connection with or for incorporation in the Works and from and against all damages, costs, charges and expenses whatsoever in respect thereof or in relation thereto, except where such infringement results from compliance with the design or specification provided by the Expert.

14. Prevention of Accident, Nuisance, Damage or Loss

- (1) The Contractor shall take all precautions necessary to ensure the safety of all persons engaged upon or visiting the Works, and observe strictly the safety regulations of Government and/or local authorities.

- (2) The Contractor shall take all precautions necessary to prevent loss or damage by fire to the Works or to adjacent property.
- (3) The Contractor shall comply with any statutory requirements relating to control of noise levels on the Site.
- (4) The Contractor shall take all precautions necessary to prevent nuisance from water, smoke, dust, rubbish and other causes.
- (5) The Contractor shall obtain permission in writing from the owner of the adjoining property if requiring to erect scaffolding on or otherwise use the adjoining property, and pay any charges in connection therewith, shall clear away and make good on completion or when directed by the adjoining owner.
- (6) The Contractor shall notify all service authorities of proposed works before commencing site operations. So far as reasonable ascertain the location of services or confirm that none exists in the vicinity of the Works, and shall not interfere with the operation of services without the consent of the service authority. If any damage results to public or private services, the Contractor shall notify the Expert and owner(s) immediately and pay all costs of reinstatement.
- (7) The Contractor shall keep the approaches to the Site clear of mud and debris and ensure that no damage is caused to public or private roads and footpaths, and bear the costs of any necessary reinstatement or making good.
- (8) The Contractor shall protect and preserve all trees and shrubs except those directed by the Expert to be removed.
- (9) The Contractor shall protect existing buildings, fences, gates, walls, cables and other features on the Site which are to remain in position during the excavation of the Works.
- (10) The Contractor shall take all necessary precautions to prevent damage to the adjoining property. Any damage occurring must be made good to the satisfaction of the Expert and/or owner(s) of the adjoining property at the Contractor's expense.

- (11) The Contractor shall report promptly to the expert all accidents involving the death of or serious injury to any person, on the site or resulting from the Contractor's operation.

15. Progress

(1) Program

The Contractor shall prepare and agree with the Expert a construction program within one week after the award of the Contract in approved form for the whole of the Works, including the works of sub-contractors and other work concurrent with the Contract immediately. And he submit one copy to the Expert, one copy to the JICA, and retain another in the site office. Submission of program will not relieve the Contractor of his obligations to apply in writing for instructions as required by the Conditions of the Contract, and receipt of program by the Expert will neither affect the Contract completion date nor relieve the Contractor of his responsibility to complete the Works by that date.

(2) Progress Report

The Contractor shall record daily progress on the copy of the construction program kept in the site office. He shall update or redraft if any circumstances arise which affect the progress of the Works, and shall submit three (3) copies of a monthly progress report with the revised construction program in a form acceptable to the Expert on the Works during the preceding month, before the ten (10) days of each month or at any time designated by the Expert. The report shall show but not be limited to:

- (a) the total percentage of progress as of the end of the report period and the percentage of each type of work progress for each structure during the preceding month,
- (b) the list of activities scheduled to be in progress or actually in progress during the report period with the Contractor's actual forecast start and/or completion date for each activity,
- (c) the list of works done, and labours and equipment used during the report period,
- (d) the list of the equipment and materials supplied by the Employer and used during the report period,

- (e) the list of activities scheduled to be started within one (1) month with forecast starting dates, and
- (f) photographs set out in Clause 15 (4) hereof.

(3) Site Meeting

From time to time during the execution of the Contract, the Expert is empowered to call meetings on the site, as he deems necessary for the purpose of control of the Contract. The Contractor shall hold a site meeting as required by the Expert, and inform sub-contractors when their presence is required. The Expert will take and distribute the minutes of meetings.

(4) Photographs

The Contractor shall, if so required, furnish photographs of the Works to the Expert in progress at the site directed by the Expert throughout the Contract period. The photographs to be furnished to the Supervisor shall be attached with monthly progress report specified in Clause 15 (2) and shall be in three (3) copies and suitably inscribed. The negatives of the photographs shall be the property of the JICA and no prints from these negatives may be supplied to any person or persons without the approval of the Expert. The cost of such photographs shall not be paid separately and shall be deemed to be included in the rates for the various items in the Bill of Quantities.

16. Contractor's Offices, Stores and Workshops

The Contractor shall provide, maintain and remove when directed, such temporary buildings as Contractor's offices, workshops and adequately fenced store compounds as are necessary for the execution of the Works.

Not less than 14 days before constructing such buildings, the Contractor shall submit site plans and general particulars to the Expert for his approval.

17. Assistance to the Expert

The Contractor shall render all necessary assistance to the Expert and shall provide as required pegs, poles, straight edges, stagings, moulds, templates, profiles and all other requisites to be used for checking and measuring the Works.

18. Water and Power Supply

The Contractor shall provide, operate, maintain and remove when directed upon completion of the Works, an adequate supply of water and electricity to his office, workshops and places of Work on the Site.

19. Subcontracting

The Contractor shall not subcontract the whole of the Works. Except where otherwise provided by the Contract, the Contractor shall not subcontract any part of the Works without the prior consent of the Expert. Any such consent shall not relieve the Contractor from any liability or obligation under the Contract and he shall be responsible for the acts, defaults and neglects of any Subcontractor, his agents, servants or workmen.

20. Material and Standard

The Contractor shall inform the Expert of the names of the persons or firms from whom he desires to obtain any materials, ironwork, pipes, manufactured articles or other things which are to be supplied by him for use in the Works and, except as regards trifling and unimportant matters, no order shall be placed except with the sanction of the Expert. The Contractor shall keep the Expert fully advised of the orders and delivery dates of materials. Delivery shall be made sufficiently in advance to enable to further samples to be taken and tested, if required.

All materials and equipment to be furnished under the Contract shall be new and shall conform to the authorized standard for materials and tests in Indonesia. Other national or international standard may be accepted provided the requirements therein are, in the opinion of the Expert, equivalent to the current issue of the said standards.

If the Contract Documents conflict in any way with any or all of the above standards or codes, the Contract Documents shall have precedence and shall govern.

21. Measurement and Payment

(1) Excavation

Measurement for excavation will be made for the net volume in cubic meters of earth excavated from the natural ground surface to the lines and grade shown on the

Drawings or as directed by the Expert. Payment for excavation measured as above shall be at the Rate entered in the Bill of Quantities, which shall include the cost of excavation, trimming of side slopes, draining, earth slip or slide prevention; laying out, constructing and maintaining catch-water drains in good order during the works; hauling and disposal of the excavated material; backfilling for structures, except if it is already covered under other items in the Bill of Quantities; removal of materials in earth slips or slides, including the costs of all materials, labour, depreciation of equipment and all else necessary therefor and incidental thereto.

(2) Backfill for Structure

Measurement for backfill for structures shall be made for the net volume of filled materials measured in cubic meters after compacting and trimming of the slope as shown on the Drawings or as directed by the Expert.

Payment for backfilling of the structures measured as above shall be made at the Contract Rate per cubic meter in the Bill of Quantities, which Contract Rate for backfilling shall include the cost of supplying suitable material, placing by hand tools or machines, mixing, harrowing (if required), spreading, trimming, watering and compacting, and the cost of all other works connected therewith. The Contract Rate shall apply whatever the source of the material.

(3) Concrete

Measurement of concrete for payment shall be made only to the neat lines of the structures as shown on the Drawings or as established by the Expert. In measuring concrete for payment, the volume of all cavities, depressions and openings shall be deducted. Payment for concrete in any concrete measured as above shall be made at the Rates in the Bill of Quantities for:

Payment of concrete in the various parts of the Work shall be made at the Rates per cubic meter in the Bill of Quantities. The Rate shall include the cost for excavation, cost of all labour and materials, depreciation of equipment required in the construction, handling of cement, and the cost for concrete form of furnishing all labour, equipment and materials, erecting and removing the forms, depreciation of the forms, scaffoldings, backfilling and also the cost of all other necessary works connected therewith.

(4) Plastering and Cement Mortar

Measurement of plastering and cement mortar for payment shall be made for the net volume in cubic meter of cement mortar shown on the Drawings or as directed by the Expert. Payment for plastering measured as above shall be at the Rate entered in the Bill of Quantities, which shall include the cost for plastering of all labour and materials except cement, depreciation of tools and equipment, and other necessary works.

(5) Reinforcing Bar

Measurement for payment for furnishing and placing reinforcing bars shall be made only of the weight of the bars placed actually in the concrete in accordance with the Drawings or as directed by the Expert. Payment for furnishing and placing of reinforcing bars shall be made at the Rate per unit weight in the Bill of Quantities, which shall include the cost of furnishing and attaching wire ties and metal supports, if used, and of delivering, unloading, hauling, storing, sorting, cutting, bending, cleaning, placing, and securing the maintaining in position all reinforcing bars, as shown on the Drawings or as directed by the Expert.

(6) Land Levelling

The measurement of land levelling for payment shall be made for only the area where the land levelling has been done in accordance with the Expert's direction at Site. The payment shall be made at the Rate provided in the Bill of Quantities, which shall include the cost of tools, labour and materials necessary for completing the works under this item including excavation, handling and hauling the excavated materials, placing and spreading in fill, smoothing and finishing the ground surface within the allowance to satisfy the Expert, and other incidental items of the Work. No extra payment shall be made for the extra volumes due to shrinkage, swelling, losses or compaction of soil, increasing or decreasing of volume to cause repairment or additional works.

(7) Compaction and Pavement of Road

Measurement for the compaction and pavement of road shall be made for only the area as shown on the Drawings or as directed by the Expert. The payment shall be made at the Rate provided in the Bill of Quantities, which shall include the cost of equipment, tools, labour and materials necessary for completing the Works under this item including excavation, handling and hauling the excavated materials, placing and

spreading in fill, smoothing and finishing the road surface within the allowance to satisfy the Expert, and other incidental items of the Works.

(8) Others

Measurement for payment for each of the items other than the items specifically mentioned above shall be made on the basis of the respective units indicated in the Bill of Quantities. The respective Contract Rate shall include the cost of furnishing all labour, materials, Constructional Plant, plant and appliance, and the performance of all work necessary to complete the Works intended to be covered under the items, including minor works not mentioned but normally deemed to form a part of the Works.

22. Submission of Document

The Contractor shall submit all important documents from or to any Government authority, local authority, public service, and official body relating to the execution of the Works attaching with the inventory to the JICA through the Expert at the Time for Completion.

23. Work at Completion

Upon the issue of any Handing-Over Certificate the Contractor shall clear away and remove from that part of the Site to which such Handing-Over Certificate relates all Contractor's equipment, surplus material, rubbish and temporary works of every kind, and leave such part of the Site and Works clean and in a workmanship condition to the satisfaction of the Expert.

The Contractor shall attend the Handing-Over inspection, and shall arrange with the Expert for joints inspection. The Contractor shall cooperate with the Expert in order to submit the documents concerned and necessary matters to the JICA.

24. Defects Liability

In any defect, shrinkage or other fault in the Works appears at any time prior to the end of the Defect Liability Period, the JICA may instruct the Contractor to search under the directions of the JICA for the cause thereof. If such defect, shrinkage or other fault is one for which the Contractor is liable, the cost of the work carried out in searching as aforesaid shall be borne by the Contractor and he shall in such case remedy such defect at his cost.

4. Technical Specification (Draft)

TECHNICAL SPECIFICATION
FOR
CONSTRUCTION OF MODEL INFRASTRUCTURE IMPROVEMENT WORKS
ON
THE ACADEMIC DEVELOPMENT OF THE
GRADUATE PROGRAM AT THE FACULTY OF
AGRICULTURAL ENGINEERING
AND TECHNOLOGY,
INSTITUT PERTANIAN BOGOR
IN
INDONESIA

INDONESIA OFFICE

JAPAN INTERNATIONAL COOPERATION AGENCY

GENERAL

1. No interruption or disturbance to the research activities at the Faculty of Agricultural Engineering and Technology, Institut Pertanian Bogor.
2. No use of the site for any purpose other than carrying out the Works.
3. The Contractor shall, with due care and diligence, execute and complete the Works and remedy any defects therein accordance with the provisions of the Contract. The Contractor shall provide all supervision, labor, materials, Plant, Contractor's Equipment and all other things, whether of a temporary or permanent nature, required in and for such design, execution, completion and remedying of any defects, so far as the necessary for providing the same is specified in or is reasonably to be inferred from the Contract.
4. The Contractor shall take full responsibility for the adequacy, stability and safety of all Site operations and the methods of construction. Provided that the Contractor shall not be responsible for the design or specification of the Works.

A. EARTHWORKS

A.01 Excavation - General

All excavation shall be carried out to the lines and levels shown on the Drawings or to such lines and levels as the Expert may direct. The Contractor shall trim all permanent excavation to the levels and dimensions shown on the Drawings.

Before commencing excavation, the Contractor shall survey and take a level over the entire area in which excavation is to be carried out. The surface level as determined shall be subject to the Expert's Approval, and measurement of excavation shall be based upon the approved surface level.

When any excavation has been taken out and trimmed, the Expert shall be informed accordingly so that he may inspect the completed excavation, and no excavation shall be filled in, covered with concrete or paved with asphalt until it is inspected and the Contractor is authorized to proceed with the Works.

If from any cause whatsoever excavation other than for concrete work are carried out beyond their true line and level other than at the direction of the Expert, the Contractor shall at his own cost make good to the required line and level with the approved material and in such a manner as the Expert may direct.

If from any cause whatsoever excavation for concrete works are carried out beyond their true line and level other than at the direction of the Expert, the Contractor shall at his own cost fill in to the required line and level with concrete similar in grade to that intended to be used in the true excavation unless otherwise directed.

A.02 Excavation for Structures

Excavation for foundation works shall be carried out in a safe manner and to the lines and levels shown on the Drawings or to such lines and levels as may be approved by the Expert. Firm foundations are to be achieved by moistening and tamping if necessary.

A.03 Excavation for Open Ditches

Excavation for Open Ditches shall be made in accordance with Clause A.01 hereof, and excavation is to be executed in such a manner as shown on the Drawings or as directed by the Expert.

A.04 Backfilling and Banking - General

No excavation for foundation works shall be backfilled before they are inspected by the Expert. Backfilling shall, unless otherwise specified, be carried out with the approved materials and shall be well compacted in accordance with the Drawings to the satisfaction of the Expert. Topsoil, vegetation or other organic material shall be excluded from backfilling material.

A.05 Banking for Farm Pond

A farm pond shall be banked up with the approved materials after the completion of land levelling as directed by the Expert. Banking shall be carried out in accordance with Clause A.04 hereof. Banking is to be executed in such a manner as to deposit the approved materials and to be completely compacted without any damage to adjacent structures, to the satisfaction to the Expert.

A.06 Fill Adjacent to Structures

Filling materials adjacent to structures shall be placed in such a manner as will ensure that they can be satisfactorily compacted without damage to the structures. Compaction adjacent to all structures shall be carried out by hand or by a suitable hand operated plant.

Unless otherwise specified, no filling materials shall be placed and no compaction shall be permitted adjacent to concrete for fourteen (14) days after the placing of the concrete.

Compaction of backfilling materials placed above buried concrete, however, mature, shall not be permitted to be carried out with vibrating rollers within 0.5 meter vertically of the surface of the concrete, except with the prior approval of the Expert.

A.07 Land Levelling

The land levelling shall include the supply of all labourers, materials and tools, excavating, hauling and filling the excavated soils, planning and finishing the ground surface, and other incidental operations pertaining to land levelling works as directed by the Expert.

The land levelling operation shall generally include the followings:

- (1) Cut of high places, haulage, fill in low places in each land levelling plot to adjust the inclinations and levels in each plot as directed by the Expert.
- (2) Cut, haulage, heaping of suitable materials for construction extracted from land levelling plot as directed by the Expert.
- (3) Planning and finishing to remove any difference in levels and to obtain a surface totally smooth and inclined to the satisfaction of the Expert.

B. CONCRETE WORKS

B.01 Cement

The Cement to be used and bought throughout the Works by the Contractor shall be ordinary Portland Cement and shall be inspected by the Expert before commencing the Works. The Portland Cement shall comply with the requirements of Indonesian Standard or its equivalent.

B.02 Storage of Cement on the Works

Immediately after the cement is handed over to the Contractor, it shall be stored in a dry, weathertight, properly ventilated structure, to adequately prevention of absorption of moisture. The Contractor's method of handling and storing cement shall be subject to the approval of the Expert.

B.03 Concrete Aggregate

All concrete aggregates are to be obtained from sources approved by the Expert. They shall be free from earth, clay, chalk, lime, loam, soft clayey shale or decomposed stone, vegetable and organic matter and other impurities. The stone shall be hard and dense.

B.04 Coarse Aggregate

The nominal sizes of the coarse aggregate in structural concrete shall be 38 millimeters, except where otherwise specified. The coarse aggregate as far as practicable, shall conform to the grading requirements.

B.05 Fine Aggregate

Grading of the fine aggregate as delivered to the mixer, as far as practicable, shall conform to the requirements.

B.06 Storage of Aggregates

Provision shall be made on the site for the separate storage of fine and coarse aggregate, as well as of each size of coarse aggregate, in such a manner as to avoid the contamination of concrete by foreign material and to prevent segregation and excessive breakage; stockpiles shall be provided with suitable drainage facilities to ensure, as far as practicable, that the aggregate delivered to the batching equipment shall have the uniform and stable moisture content directed by the Expert. Aggregate shall, during hot weather, be covered to protect them from the direct rays of the sun.

B.07 Mixing Water

Water from mixing concrete, mortar, and rendering shall be subject to the approval of the Expert. It shall be clean, fresh and free from oil, acid, alkali, sugar and vegetable substances, and it shall, be free of organic or inorganic matters in solution or suspension in such amount that it may impair their strength, appearance of durability.

B.08 Concrete Mixer

Concrete shall consist of cement, graded aggregates and water thoroughly mixed and compacted to provide strengths as detailed below:

Type of Concrete Mix	Maximum Size of Aggregate	Specified Compressive Strength at 28 Days
1 : 2 : 4	38 mm	225 kg/cm ²
1 : 3 : 6	38 mm	175 kg/cm ²

The type of concrete mixing is indicated by the volumetric proportion of cement, fine aggregate and coarse aggregate. The mix proportion shown in the table above are given as a guide to the mixing ordinarily needed to achieve the specified strength and shall not relieve the Contractor of the responsibility to obtain the specified strength.

B.09 Batching

Aggregate and cement may be proportioned by volume in the accurately calibrated gauge boxes unless otherwise directed by the Expert.

B.10 Mixing Concrete by Machine

The materials for concrete shall be mixed in an approved mechanical mixer. The mixing time for each batch shall not be less than the minimum mixing time, shall not exceed three (3) times the minimum time, and shall be constant for a series of batches of concrete for a particular structure.

The mixer shall not be loaded beyond their rated capacity, nor shall they be operated at a speed in excess of that recommended by the manufacturer. They shall produce a concrete of uniform consistency and appearance, at a continuous rate approved by the Expert.

All mixing equipment shall be clean before commencing mixing, and shall be kept free from set concrete.

B.11 Mixing Concrete by Hand

Where it is not possible to employ a mixing machine and approval is obtained from the Expert, concrete shall be mixed by hand, as near as practicable to the site where it is to be deposited. Clean mixing bankers or platforms having sufficient areas for the proper execution of the Work shall be provided. The platforms if constructed of timber shall consist of plants closely jointed so as to avoid the loss of any grout or liquid from the wet concrete. The whole of the aggregate and cement shall be turned over on the banker in a dry state at least twice. The water shall then be added gradually through a rose head, after which the materials shall again be entirely turned over in a wet state at least three (3) times before leaving the banker.

B.12 Protection of Concrete in Unfavorable Weather

No concreting will be allowed in the open during storms or heavy rains. All concreting materials and plant are to be adequately protected against the effects of heavy storms and strong winds.

B.13 No Partially Set Material to be Used

All concrete and mortar must be placed and compacted within 30 minutes of its being mixed; no partially set material shall be used in the Work.

B.14 Concrete Depositing

The arrangements for placing concrete are to be such that in all cases the material may be conveniently handled and placed in the required position as directed by the Expert without re-handling or segregation. Wherever possible concrete is to be deposited from bottom opening skips and in all cases shall be deposited in layers of such depth that each layer can be easily incorporated with the layer below with the use of internal vibrators or by spading, slicing, and ramming. Concrete shall not be delivered by shoot or dropped from barrows or otherwise handled through a height greater than 1.5 meters except with the approval of the Expert who may order the concrete to be dropped on to a banker and to be turned over by hand before being placed.

The area on which any concrete is to be deposited must be made and maintained free from standing water during concrete placing unless otherwise approved. Running water crossing or entering such areas must be brought under control before concreting proceeds.

Concrete in reinforced concrete works shall be deposited in small quantities in a plastic state with a water cement ratio to give the specified strength. The depositing of concrete in individual member shall be continued without stoppage up to an approval pre-arranged construction joint or until the member is completed and shall be finished off in such manner that the junction of members shall be monolithic unless otherwise specified.

B.15 Compaction of Concrete

Concrete shall, during placing, be compacted by vibrators or any other compaction tools of approved type. Compaction shall continue until the concrete being placed shall be judged to be compacted by the appearance of a blistering and even surface except for slight irregularities where the coarse aggregate break through. All air shall this time be expelled.

B.16 Curing and Protection

The Contractor shall take adequate measures to ensure that concrete is cured. These shall include overing concrete with burlap matting or other effective means which shall be kept damp continuously for a minimum period of three (3) days after casting or for such other time as the Expert may direct. After removal of this covering, the concrete shall then be sprayed with water for a minimum period of a further seven (7) days. Other methods of preventing the water of hydration in the concrete from evaporating may be used with the approval of the Expert.

All concrete liable to be affected by running water or wave action shall be adequately protected from damage during the setting period and all temporary protective works shall be erected to the satisfaction of the Expert.

B.17 Embedded Items

Before placing concrete, care shall be taken to determine that all embedded items are securely fastened in place as shown on the Drawings or as otherwise directed. All embedded items shall be thoroughly clean and free from oil and other foreign matters such as loose coatings of rust, paint, scale, mortar, etc. The embedding of wood in concrete shall be prohibited unless specifically authorized.

Any concrete flumes or other materials embedded in structures under the Contract, as construction expedients, shall conform to the above requirements and upon completion of their use, shall be backfilled with concrete at no extra cost to the Employer.

B.18 Formwork

Forms shall be used, wherever necessary, to confine the concrete and shape it to the required lines. All exposed concrete surface having slopes steeper than 1:1 shall be formed, unless otherwise directed or approved by the Expert.

Forms shall be simple; they shall be rigidly constructed of approved materials and shall be braced and strutted to withstand the pressure resulting from placing and vibrating the concrete, constructional loads, wind and other forces without appreciable deformation.

The surface of the forms to be in contact with concrete shall be free from adhering foreign matter, projecting nails and the like, grooves, splits or other defects. Shutting boards shall be carefully jointed and so arranged as to be able to swell under the influence of humidity of the concrete, without causing any deformation to the forms. Interstices shall be properly filled with glazier's putty and the water-proofing of the forms shall be sufficient to prevent escape of cement resulting from excess of water in concrete. However, paper tamping shall not be used unless otherwise approved by the Expert.

A non-staining commercial mineral oil or other approved materials shall be applied to the faces of the forms before concreting to prevent adherence to the concrete. Care must be exercised to prevent the material applied to the faces of the forms from coming in contact with the reinforcement, but if this should inadvertently occur, the reinforcement must be cleaned.

When forms have been built and have been prepared ready for concreting, they will be inspected by the Expert and no concrete shall be placed until the forms are approved by him. In order to avoid delays in obtaining approval, the Contractor shall inform the Expert, at least 24 hours in advance, of his intention to have the forms ready for inspection.

The Contractor shall take full responsibility that the proper time has elapsed for concrete to attain sufficient strength before forms are removed. Nevertheless, the forms shall not be struck without the prior approval of the Expert, and in any case at least three (3) days shall elapse before forms are struck.

Connections shall be so formed as to permit the easy removal of the forms without hammering, etc., and without the necessity of levering against the surface of the concrete.

B.19 Reinforcing Bar

Reinforcing bar for concrete shall be deformed not-rolled milled steel bars complying with Indonesian Standard, or its equivalent, and shall be recommended to the Contractor by the Expert as required.

The Contractor's method of handling and storing reinforcing bar shall be subject to the approval of the Expert.

B.20 Placing of Reinforcing Bar

The number, size, form and position of all reinforcing steel bars, fabric, ties, links, stirrups and other parts of the reinforcement are to be placed in exact accordance with the Drawings and kept in the correct position in the forms without displacement during the process of vibrating, tamping and ramming concrete in place. The Contractor shall provide all necessary distance pieces and space bars at his own cost to maintain reinforcement in the correct position. Any ties, links or stirrups connecting the bars shall be tightened so that the bars are properly braced, the inside of their curved parts shall be in actual contact with the bars around which they are intended to fit. Bars shall be bound together with the best black annealed mild steel wire which is subject to the Expert's approval, and the binding shall be twisted tight with proper pliers. The free ends of the binding wire shall be bend inwards.

The Contractor shall provide, at his own cost and to the approval of the Expert, working drawings of all reinforcement accompanied by bending schedules and copies of the orders placed for bars.

Before any steel reinforcement is embedded in the concrete any scale, loose rust, oil, grease or other deleterious matter shall be removed. Partially set concrete which may be adhering to the exposed bars during concrete placing shall likewise be removed.

When reinforcement bar has been placed and is ready for concreting, it will be inspected by the Expert and no concrete shall be placed until reinforcement has been approved by him. The Contractor shall inform the Expert at least 24 hours in advance of his intention to have reinforcement ready for inspection.

The minimum concrete cover of reinforcement bar measured from the outside of the bar shall be 3 centimeters.

C. ROADWAY WORKS

C.01 Subgrade

(1) General

The subgrade shall be that part of the work which is prepared for the support of the subbase or, if there is no subbase, the base of the pavement structure. It shall extend to the full width of the roadbed including the shoulders as shown on the Drawings. Any organic material shall not remain on any road subgrade.

(2) Execution of Work

Culverts, drain pipes and any other minor structures below the subgrade level, including the fully compacted backfill over them, if necessary to within 30 cm of the subgrade, shall be completed before work is begun on the subgrade. Ditches, drains, outlets for drainage, and catch basins for culverts shall be in such operative condition as to ensure prompt and effective drainage and to avoid damage to the subgrade by surface water.

No work shall be started on the preparation of the subgrade before the prior work herein described have been approved by the Expert.

All layers of subgrade shall be compacted to at least 90 percent of the maximum dry density as determined according to JIS A-1211, CBR Test unless otherwise directed by the Expert. Rollers of approved size and type, accepted by the Expert, shall be used for compaction, and the moisture content shall be properly adjusted to obtain the dry density specified above.

All completed portions of the subgrade shall be protected against drying out and cracking, and any damage resulting from default of the Contractor shall be repaired as directed by the Expert.

The Contractor shall be responsible for all the consequences of traffic being admitted to the subgrade, and he may prohibit such traffic if he has provided a detour or is operating half-width construction.

The Contractor shall repair all ruts or ridges occasioned by his own traffic or that of others by reshaping and compacting them with rollers of the size and type necessary

for such repair. He shall limit the amount of subgrade preparation to an area that can be maintained with the equipment available.

The Contractor shall arrange for subgrade preparation and subbase or base placing to follow each other closely. The subgrade, when prepared rapidly in relation to the laying of the subbase, is liable to deteriorate, and in such case the Contractor shall repair, reroll, or recompact the subgrade as may be necessary to restore it to the state specified herein.

C.02 Base Course

(1) Sub-base Course

Sub-base material shall consist of a natural or artificial mixture of hard, durable particles of coarse aggregate and soil binder. The material shall be free from soft or decomposed particles and excess clay, and shall be uniformly graded so that it can be compacted into a hard dense mass. Sub-base course aggregates shall conform to the following gradings:

Nominal Size (mm)	Percent Passing by Weight
40	90 - 100
20	60 - 85
5	45 - 65
2	30 - 50
0.5	10 - 25
0.074	5 - 15

Sub-base materials shall be placed and compacted in layers. Each layer shall be compacted to not less than 95 % maximum dry density or such other percentage as may be determined by the Expert as a result of tests. In addition the corrected CBR of the sub-base shall not be less than 20 % as determined by JIS A-1211. The water content at the time of compaction shall be the optimum water content as determined by the above test or as directed by the Expert. The finished surface shall not deviate more than 3 cm from the designated elevation, and the completed thickness of the sub-base course shall be within plus or minus 10 % of the designated thickness.

(2) Base Course

Base course material shall consist of mixtures of gravel and crushed gravel and/or rock fragments of uniform specific gravity with silt and clay conforming to the following requirements, or of stone for hand pitched bases hereinafter specified:

Nominal Size (mm)	Percent Passing by Weight
40	100
20	60 - 100
10	50 - 90
5	35 - 75
2	25 - 60
0.5	15 - 30
0.2	6 - 20
0.074	3 - 8

Stone for hand pitched bases shall be of selected stones, roughly with prismoidal shape having one dimension of at least 100 mm. Smaller stones will be necessary to fill the interstices between the larger stones.

The Contractor may use either of the above crushed stone bases or hand packed stone basis as directed by the Expert.

Compaction and finishing works shall conform to the provision in Clause C.02 (1) except for the corrected CBR of the base being not less than 60 % as determined by JIS A-1211.

Prior to the placing of the base course, the Contractor shall furnish his detailed schedule, method and equipment to be used for bituminous surfacing works for the Expert's approval.

C.03 Asphalt Pavement of Surface Course

(1) Bituminous Prime Coat

Prior to the placing of the bituminous material, the finished surface of the base course shall be completed in accordance with the provisions specified in Clause C.02 (2). Immediately after completion of rolling, all loose dirt and other objectionable material shall be removed from the surface of the base course and the surface shall be cleaned. The surface shall be sprayed with the bituminous materials for the prime cost, which shall conform to medium curing cutback asphalt (MC-30, AASHO M82 or equivalent) or straight run asphalt of penetration grade of 80 - 100, and shall be approved by the Expert.

In general the bituminous material shall be applied at a rate of 1.25 to 1.75 l/m² as directed by the Expert. The distributor shall be so designed, equipped, maintained, and operated that bituminous material may be applied uniformly on the road surface at an even temperature.

Traffic shall not be permitted on the prime coated surface until the bituminous material has penetrated and dried and in the opinion of the Expert, will not pick up under traffic, provided that if it becomes necessary to permit traffic prior to that time, but in no case sooner than 12 hours after the application of bituminous material, 'blotter' material shall be applied as directed by the Expert and traffic shall be permitted to use the road so treated.

(2) Aggregates

Aggregates for the various designations of surface treatment shall be crushed gravel or crushed stone, and shall meet the requirement for gradings.

Crushed gravel, crushed stone, or crushed slag shall consist of clean, tough, durable fragments free from dirt or other objectionable matter.

(3) Bituminous Materials

Bituminous materials shall be of the type and grade as directed by the Expert, and shall conform to the requirements of the straight run asphalt having a penetration grade of 80 - 100, or as directed by the Expert.

(4) Execution of Work

The contractor shall maintain the prime coated surface for a minimum of five days before covering it with the surfacing or next course, unless a shorter period is approved by the Expert. Prior to application of the surfacing or next course, any surface breaks shall be patched and all excessive 'blotter' material, dirt, and other objectionable materials shall be removed by seeping.

Prior to placing the first layer of surface treatment, loose dirt and other objectionable material shall be removed from the existing surface. If so directed by the Expert, the surface shall be cleaned with a broom or blower upon the Expert's approval.

Bituminous surface treatment shall be applied using quantities as specified on the Drawings, or as directed by the Expert. Each spreading of aggregate shall immediately follow application of bituminous material, except where the first spreading is required to be placed directly on the previously bituminized surface.

Bituminous material shall be so applied that uniform distribution is obtained at all points. Application temperature shall be within the range of 140 °C to 160 °C, or as directed by the Expert.

Spreading and shaping of each layer of aggregate for all designations of surface treatment shall be done with the approved aggregate spreading equipment.

Following spreading and smoothing, each layer of aggregate shall be rolled as directed. The final layer of treatment shall be alternately broom dragged and rolled thoroughly until the surface is fully compacted and bonded to full width.

C.04 Cement Concrete Pavement of Surface Course

(1) Material

This work shall consist of constructing a pavement of portland cement concrete on a prepared base in accordance with the Specifications and the Drawings.

a. Portland Cement

Portland cement shall conform to the requirements mentioned in Clause B.01.

b. Fine Aggregate

Fine aggregate shall conform to the requirements mentioned in "Concrete Works".

c. Coarse Aggregate

The coarse aggregate shall conform to the requirements mentioned in Clause B.04.

d. Combined Aggregate

The aggregate shall unless otherwise ordered by the Expert be combined in proportions to produce a mixture within the grading limits for combined aggregates shown below.

Grading of Combined Aggregates

US Standard Sieve mm	alternative	Percent passing by Weight
75	(3")	-
63	(2-1/2")	-
50	(2")	100
37.5	(1-1/2")	80-100
25	(1")	50-86
19	(3/4")	45-75
9.5	(3/8")	38-55
4.75	(No.4)	30-45
2.36	(No.8)	23-38
1.18	(No.16)	17-33
0.600	(No.30)	10-22
0.300	(No.50)	4-10
0.150	(No.100)	1-3
0.075	(No.200A)	0-2

e. Storage of Cement and Aggregate

The storage of materials shall comply with the requirement mentioned in Clauses B.02 and B.06.

f. Water

The water shall conform to the requirements mentioned in Clause B.07.

(2) Execution of Work

The execution of work of the concrete pavement shall conform to the requirements mentioned in Clause B "Concrete Works".

One line of Tractor Test Road shall be paved with cement concrete with a required thickness as shown on the Drawings or as directed by the Expert.

D. STONE WORKS

D. 01 General

This Clause covers the stone works for slope protection such as wet masonry and dry masonry as shown on the Drawings or as directed by the Expert.

D.02 Wet Masonry

(1) Material

The stone for wet masonry to be used and brought throughout the Works by the Contractor shall be natural cobblestone taken from the deposit of a river or the quarry, and shall be inspected by the Expert before commencing the Works. Its shape shall be an irregular cube having sufficient strength and durability required, and the minimum size shall not be less than 20 cm unless otherwise shown on the Drawings or directed by the Expert. The Contractor shall show the type, strength, size of material, sample and source of material to the Expert for approval.

(2) Execution of Work

The Contractor shall construct the wet masonry for elsewhere as shown on the Drawings or as directed by the Expert.

The wet masonry shall be constructed on the compacted foundation as shown on the Drawing or as directed by the Expert.

The cobblestone shall be hand-placed with uncoursed close joint to the lines and grades as shown on the Drawings or as directed by the Expert.

The cobblestone shall be placed with 1 : 3 cement mortar after having the joint thoroughly moistened. The spaces between the stones and the surface joint shall be directed by the Expert. The expansion joints with elastic joint filler, 10 mm in thickness, shall be provided at intervals of 20 m in the base and top concrete and along the partition wall concrete.

After concreting of the wet cobble masonry, it shall be cured with water for more than 10 days as approved by the Expert.

Weepholes with polyvinyl chloride (PVC) pipes with a diameter of 5 cm and filter shall be provided as directed by the Expert.

D.03 Slope Protection of Farm Pond and Dry Masonry

(1) The stone for dry masonry to be used and brought throughout the Works by the Contractor shall be of the same quality and size as stipulated in Clause D.02 above, and shall be inspected by the Expert before commencing the Works. Meanwhile the stone for slope protection of farm pond shall be as shown on the Drawings or as directed by the Expert.

(2) Execution of Work

The Contractor shall construct the slope protection of the farm pond or elsewhere, as shown on the Drawings or as directed by the Expert.

The dry masonry shall be constructed on the compacted stone bedding as shown on the Drawings or as directed by the Expert.

The rubble stone shall be hand-placed with uncoursed close joint with the filling gravel as shown on the Drawings or as directed by the Expert. The spaces behind the stones shall be filled with backfilling gravel, normally 30 cm in thickness. The base and top concrete shall be provided with expansion joints with electric joint filler, normally at 20 m intervals unless otherwise directed by the Expert.

(3) Others

The Contractor shall submit to the Expert for approval the layout and drawings of slope protection of farm pond as well as the stability analysis based on the shearing test, etc.

5. Drawings

DRAWING LIST

DRAWING NO.	DRAWING TITLE
1.	GENERAL PLAN
2.	LAND LEVELLING
3.	LINK ROAD VERTICAL SECTION OF LINK ROAD : A AND LINK ROAD : B
4.	LINK ROAD AND TRACTOR TEST ROAD VERTICAL SECTION OF LINK ROAD : C AND TRACTOR TEST ROAD : D
5.	LINK ROAD, TRACTOR TEST ROAD AND FARM ROAD TYPICAL SECTION
6.	IRRIGATION AND DRAINAGE SYSTEM FARM POND
7.	IRRIGATION AND DRAINAGE SYSTEM TYPICAL SECTION OF IRRIGATION AND DRAINAGE CANAL, CROSSING OF LINK ROAD AND CROSSING OF FARM ROAD
8.	SOIL CONSERVATION TEST FIELD



To Campus

To Leuwiliang

To Leuwiliang

To Leuwiliang

To Leuwiliang

To Leuwiliang

To Leuwiliang

To Leuwiliang

To Leuwiliang

To Leuwiliang

To Leuwiliang

To Leuwiliang

To Leuwiliang

To Leuwiliang

To Leuwiliang

To Leuwiliang

To Leuwiliang

To Leuwiliang

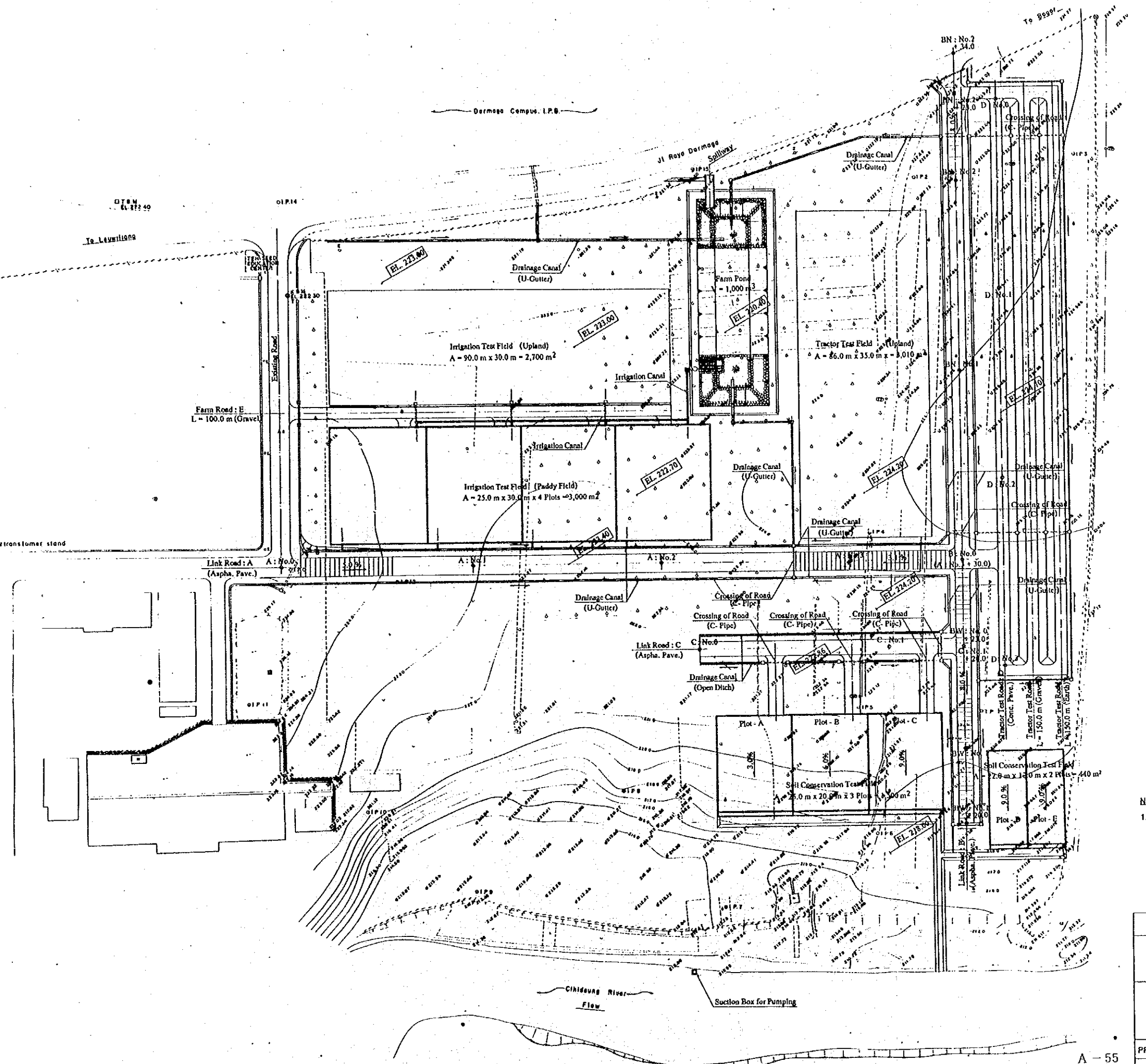

Note
 1. Locations of facilities are subject to change by the Expert.

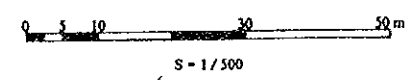

JAPAN INTERNATIONAL COOPERATION AGENCY	
THE MODEL INFRASTRUCTURE IMPROVEMENT WORKS FOR ACADEMIC DEVELOPMENT OF THE GRADUATE PROGRAM THE FACULTY OF AGRICULTURAL ENGINEERING AND TECHNOLOGY INSTITUT PERTANAHAN BOGOR	
GENERAL PLAN	
PREPARED BY	DRAWING NO.
CHECKED BY	1

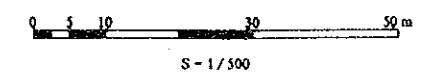
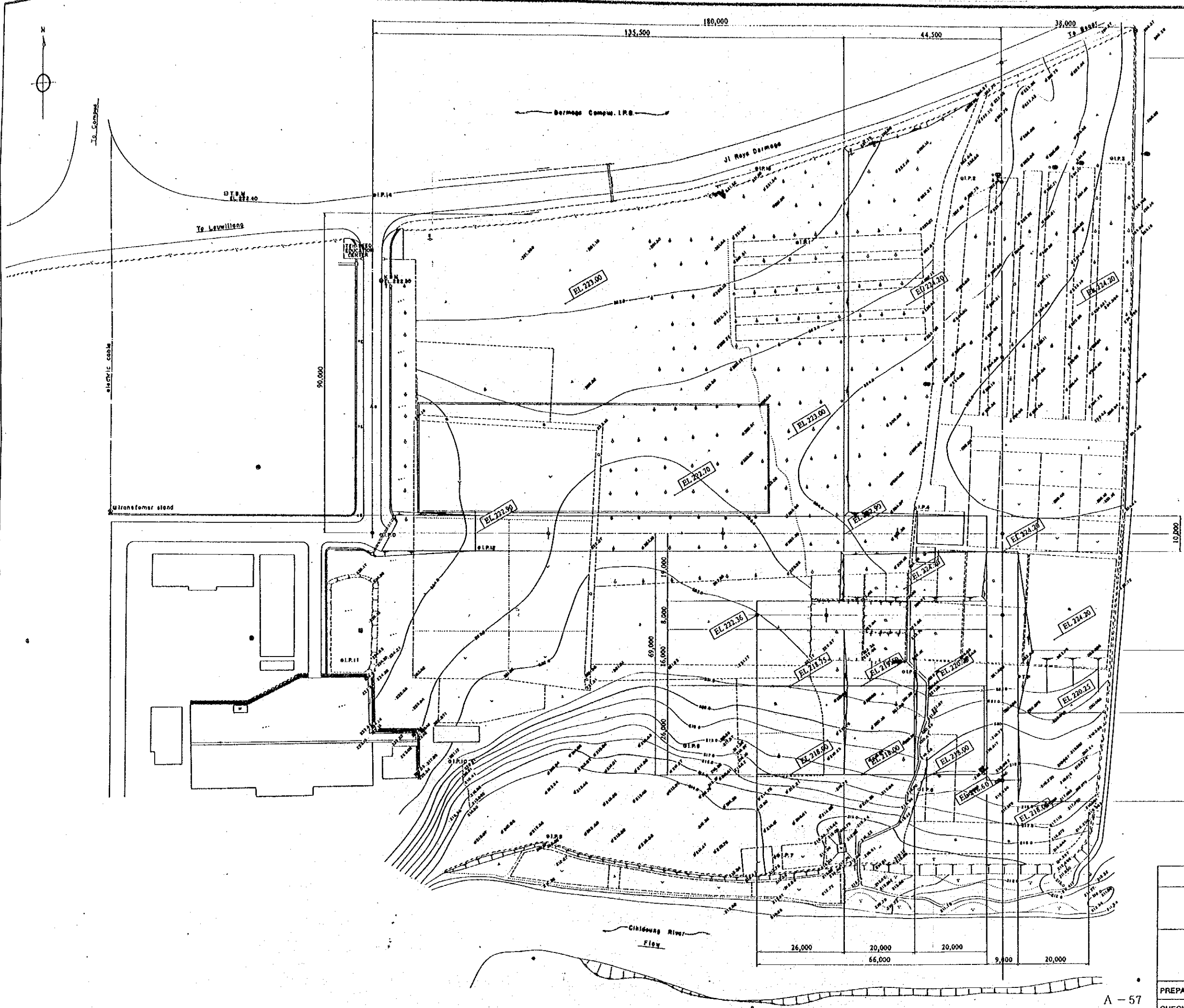

JAPAN INTERNATIONAL COOPERATION AGENCY	
THE MODEL INFRASTRUCTURE IMPROVEMENT WORKS FOR ACADEMIC DEVELOPMENT OF THE GRADUATE PROGRAM THE FACULTY OF AGRICULTURAL ENGINEERING AND TECHNOLOGY INSTITUT PERTANIAN BOGOR	
LAND LEVELLING	
PREPARED BY	DRAWING NO.
CHECKED BY	2

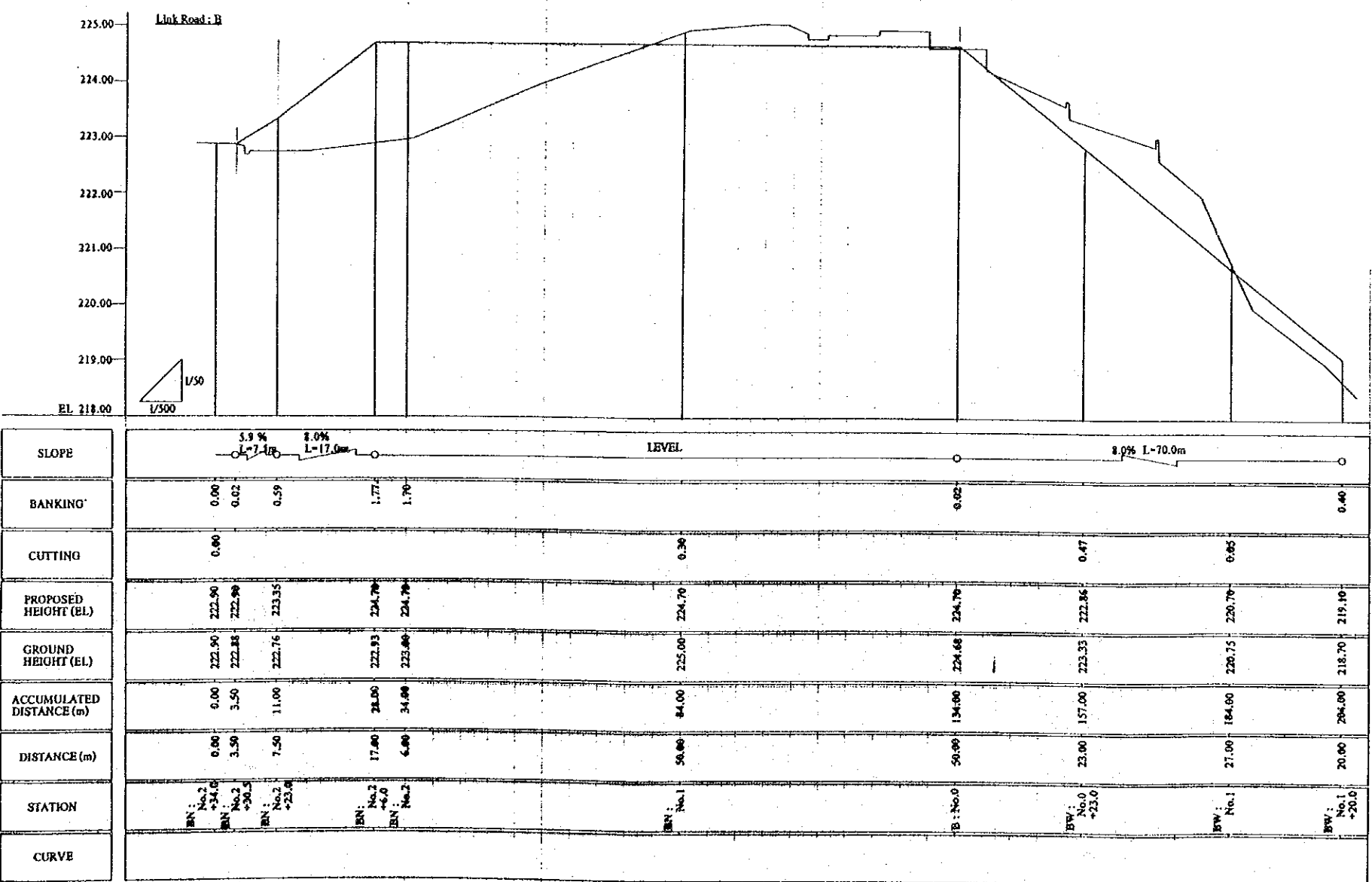
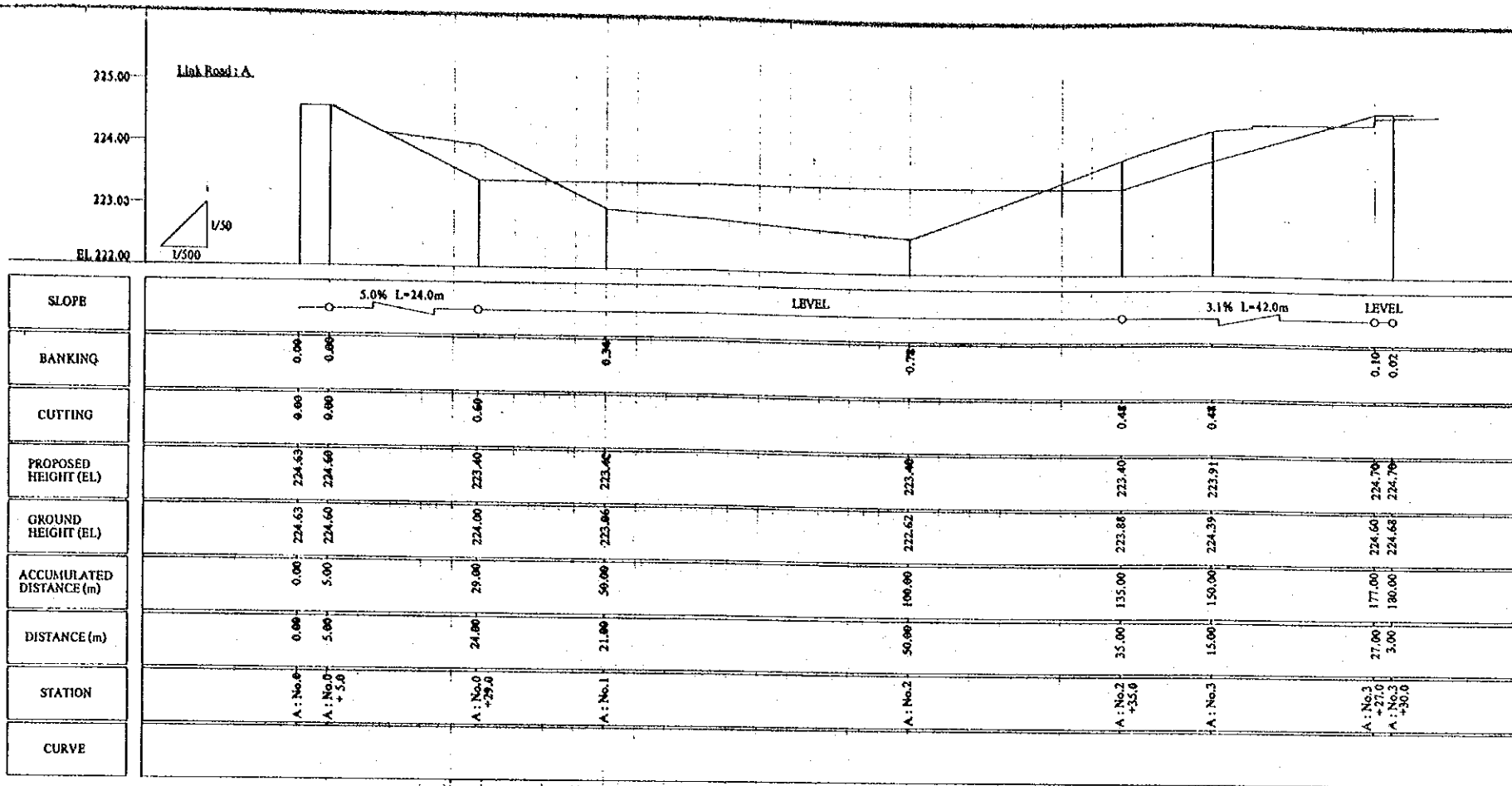

Note
1. Final elevation and inclination of the Road are subject to change according to the land levelling works.

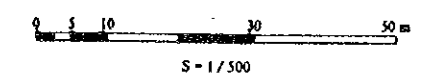

JAPAN INTERNATIONAL COOPERATION AGENCY

THE MODEL INFRASTRUCTURE IMPROVEMENT WORKS FOR ACADEMIC DEVELOPMENT OF THE GRADUATE PROGRAM THE FACULTY OF AGRICULTURAL ENGINEERING AND TECHNOLOGY INSTITUT PERTANIAN BOGOR

LINK ROAD VERTICAL SECTION OF LINK ROAD: A AND LINK ROAD: B

PREPARED BY _____ DRAWING NO. 3

CHECKED BY _____

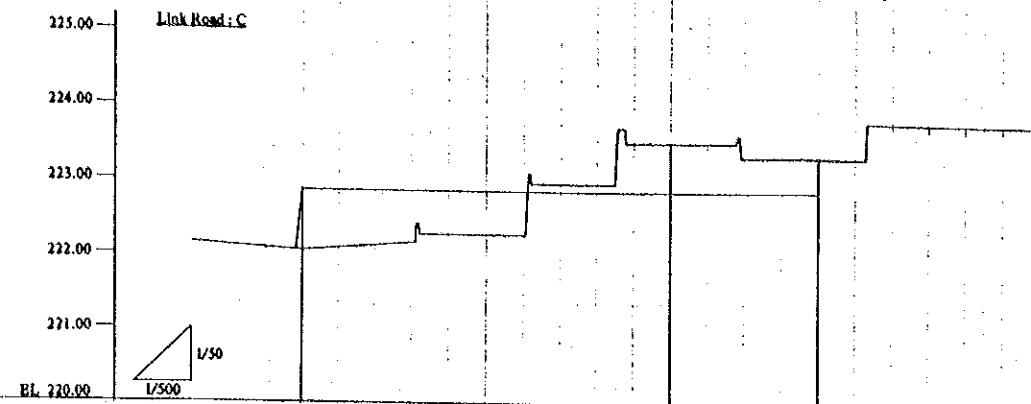

SLOPE	LEVEL		
BANKING	0.81		
CUTTING		0.64	0.47
PROPOSED HEIGHT (EL)	222.86	222.86	222.86
GROUND HEIGHT (EL)	222.05	223.50	223.33
ACCUMULATED DISTANCE (m)	0.00	50.00	70.00
DISTANCE (m)	0.00	50.00	20.00
STATION	C : No.0	C : No.1	C : No.1 +20.0
CURVE			

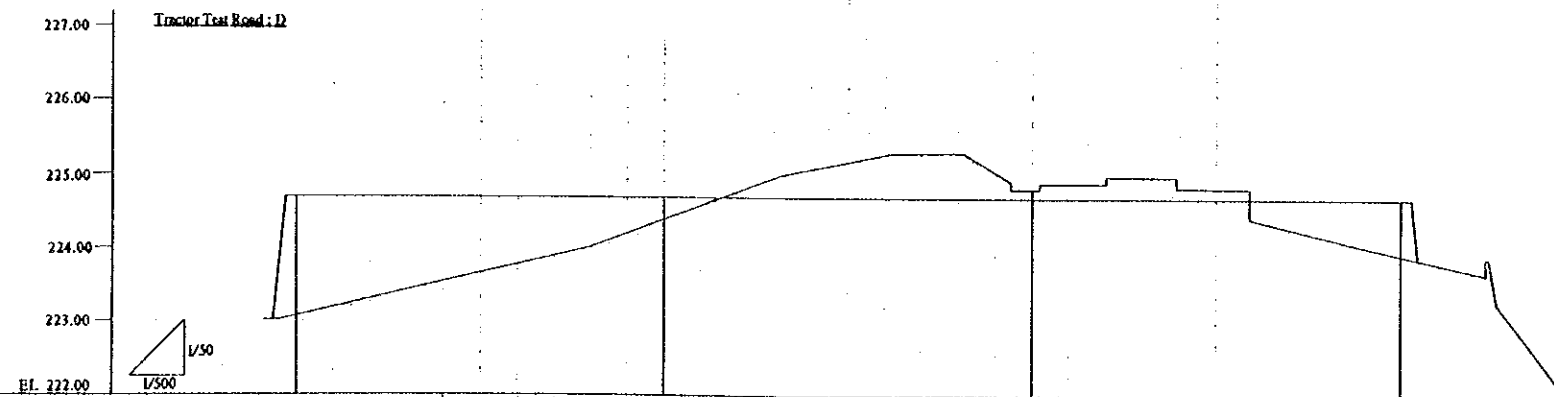

SLOPE	LEVEL			
BANKING	1.65	0.51		0.75
CUTTING			0.11	
PROPOSED HEIGHT (EL)	224.70	224.70	224.70	224.70
GROUND HEIGHT (EL)	223.05	224.39	224.81	223.95
ACCUMULATED DISTANCE (m)	0.00	50.00	100.00	150.00
DISTANCE (m)	0.00	50.00	50.00	50.00
STATION	D : No.0	D : No.1	D : No.2	D : No.3
CURVE				

Notes

1. Final elevation and inclination of the Road are subject to change according to the land levelling works.
2. Design figures of the Tractor Test Road : D are applied to other Tractor Test Roads.

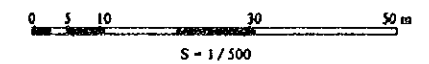

JAPAN INTERNATIONAL COOPERATION AGENCY	
THE MODEL INFRASTRUCTURE IMPROVEMENT WORKS FOR ACADEMIC DEVELOPMENT OF THE GRADUATE PROGRAM THE FACULTY OF AGRICULTURAL ENGINEERING AND TECHNOLOGY INSTITUT PERTANAHAN BOGOR	
LINK ROAD AND TRACTOR TEST ROAD VERTICAL SECTION OF LINK ROAD : C AND TRACTOR TEST ROAD : D	
PREPARED BY	DRAWING NO. 4
CHECKED BY	

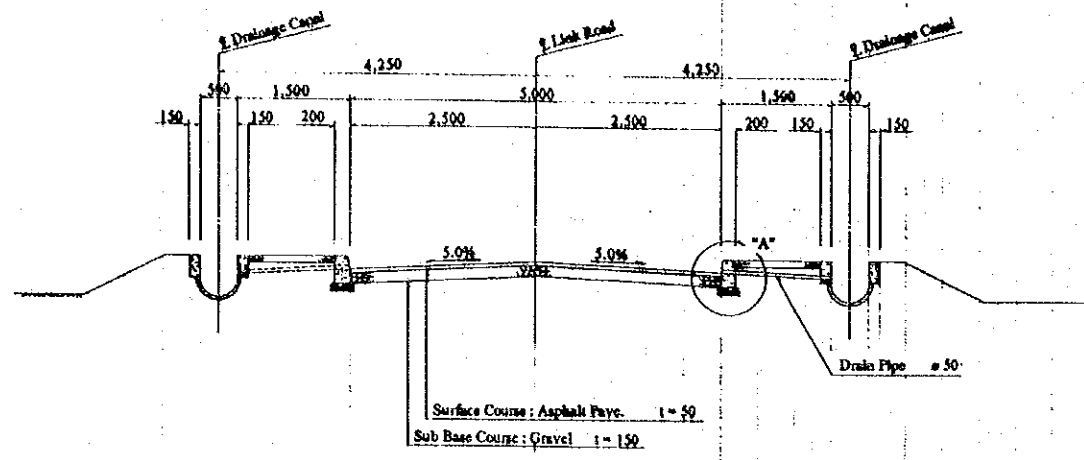

LINK ROAD : A
(FOR ASPHALT PAVE.)

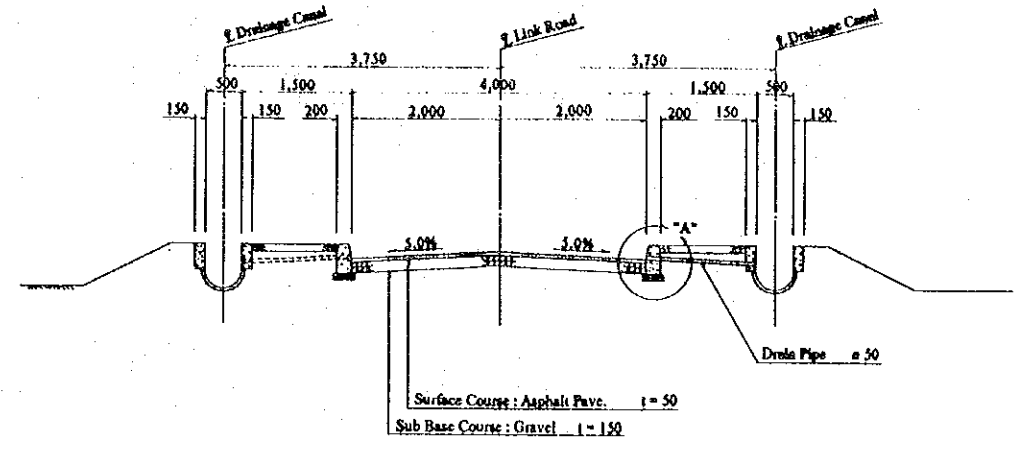

LINK ROAD : B & C
(FOR ASPHALT PAVE.)

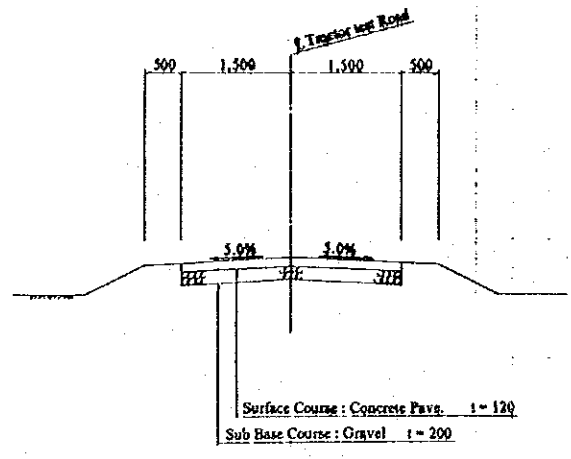

TRACTOR TEST ROAD : D
(FOR ASPHALT PAVE.)

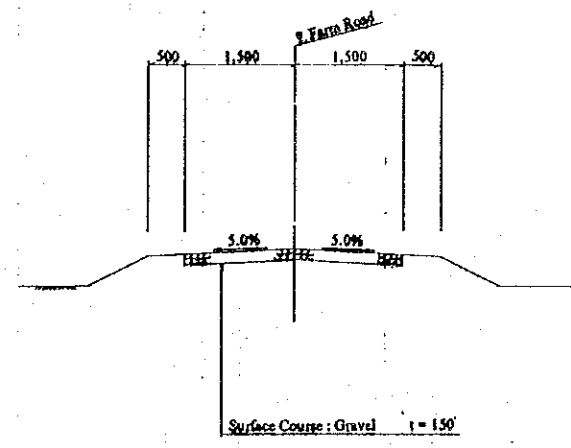

TRACTOR TEST ROAD & FARM ROAD : E
(FOR GRAVEL)

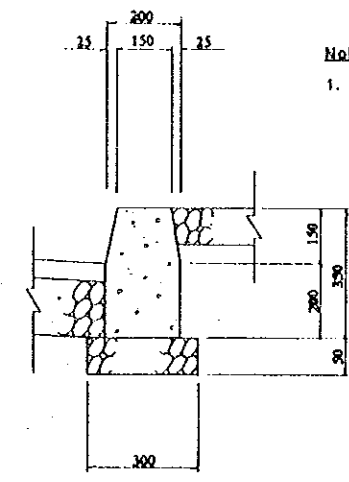

DETAIL : A
CURB

Note
1. The details are subject to change and directions by the Experts.

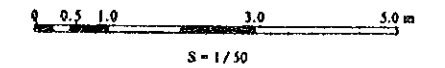

JAPAN INTERNATIONAL COOPERATION AGENCY	
THE MODEL INFRASTRUCTURE IMPROVEMENT WORKS FOR ACADEMIC DEVELOPMENT OF THE GRADUATE PROGRAM THE FACULTY OF AGRICULTURAL ENGINEERING AND TECHNOLOGY INSTITUT PERTANAHAN BOGOR	
LINK ROAD, TRACTOR TEST ROAD AND FARM ROAD TYPICAL SECTION	
PREPARED BY	DRAWING NO.
CHECKED BY	5

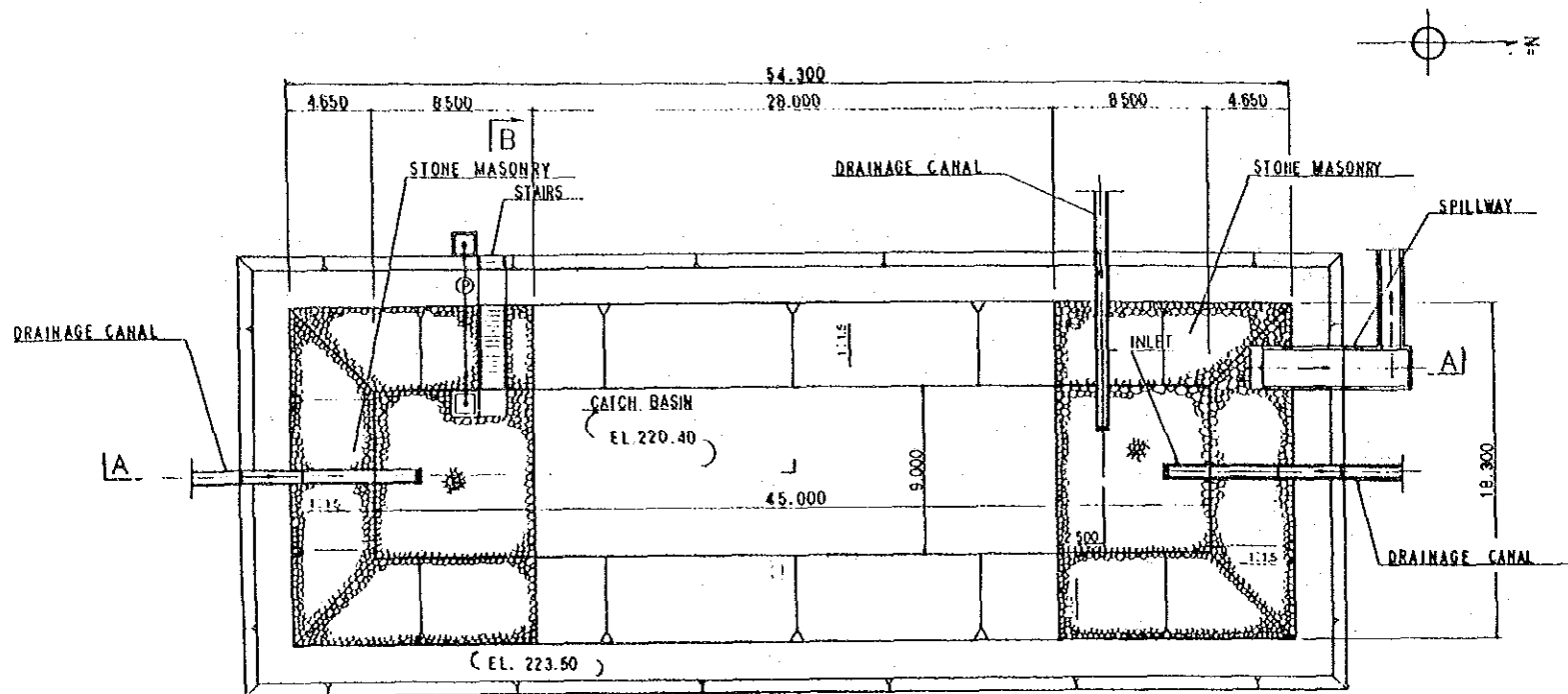

PLAN S=1/200

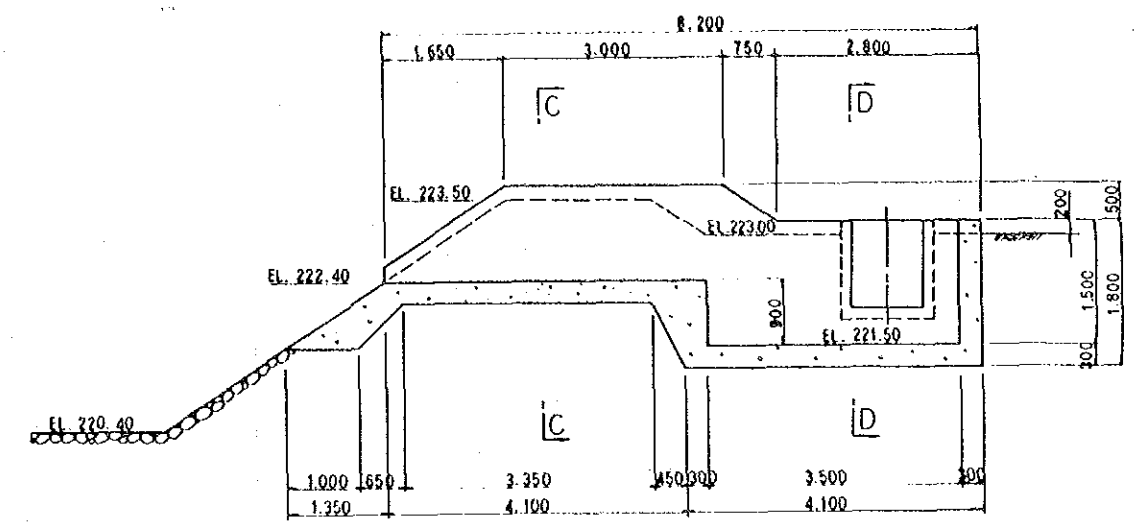

SPILLWAY S=1/10

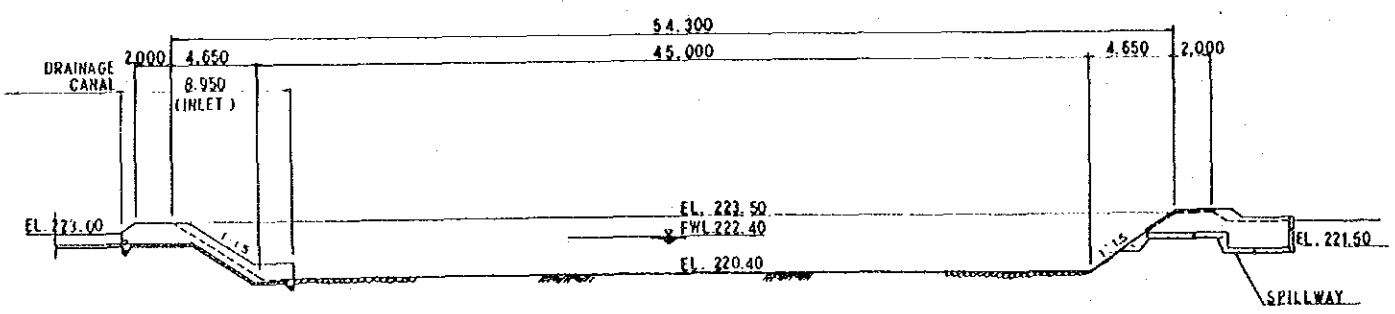

SECTION A-A

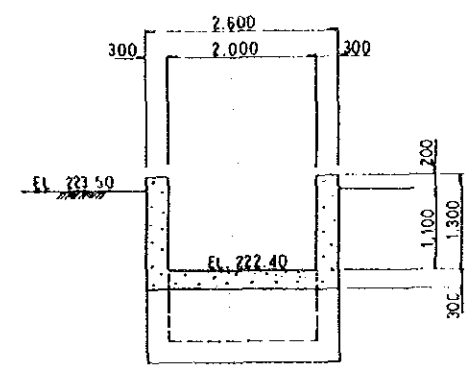

SECTION C-C

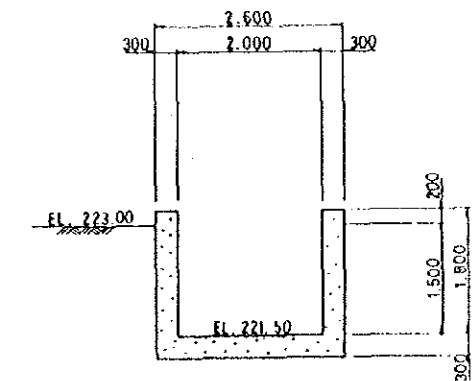

SECTION D-D

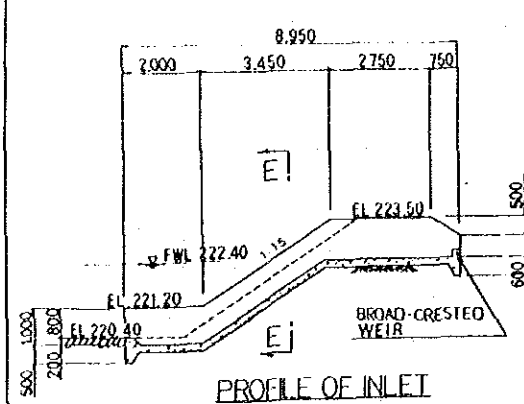

PROFILE OF INLET

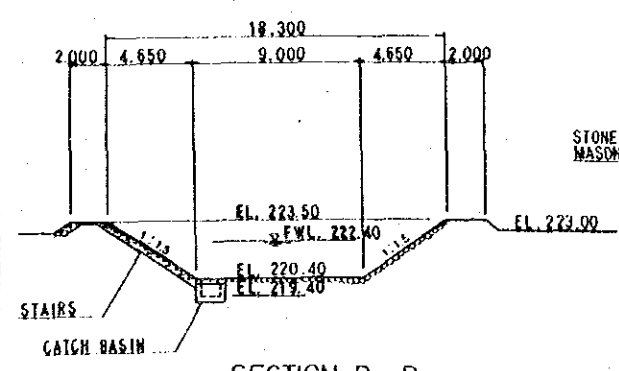

SECTION B-B

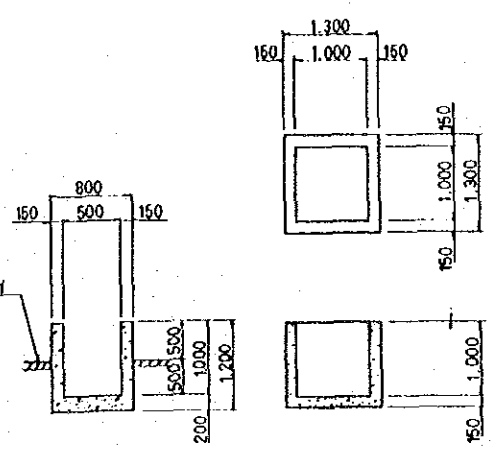

SECTION E-E

CATCH BASIN S=1/50

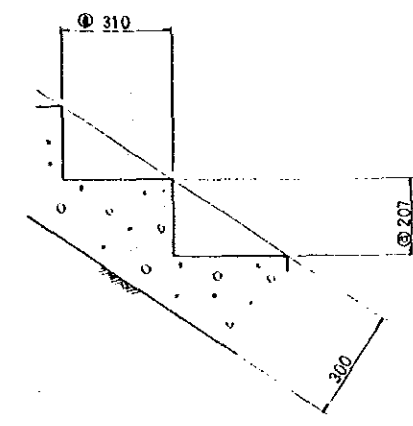

STAIRS S=1/10

Notes

1. Locations and details of facilities are subject to change and directions by the Expert.
2. Final elevations of facilities are subject to change according to the land levelling works.

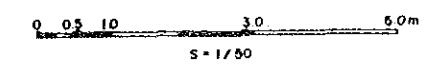
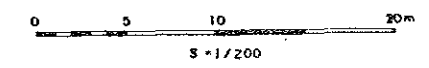

JAPAN INTERNATIONAL COOPERATION AGENCY	
THE MODEL INFRASTRUCTURE IMPROVEMENT WORKS FOR ACADEMIC DEVELOPMENT OF THE GRADUATE PROGRAM THE FACULTY OF AGRICULTURAL ENGINEERING AND TECHNOLOGY INSTITUT PERTANIAN BOGOR	
IRRIGATION AND DRAINAGE SYSTEM FARM POND	
PREPARED BY	DRAWING NO.
CHECKED BY	6

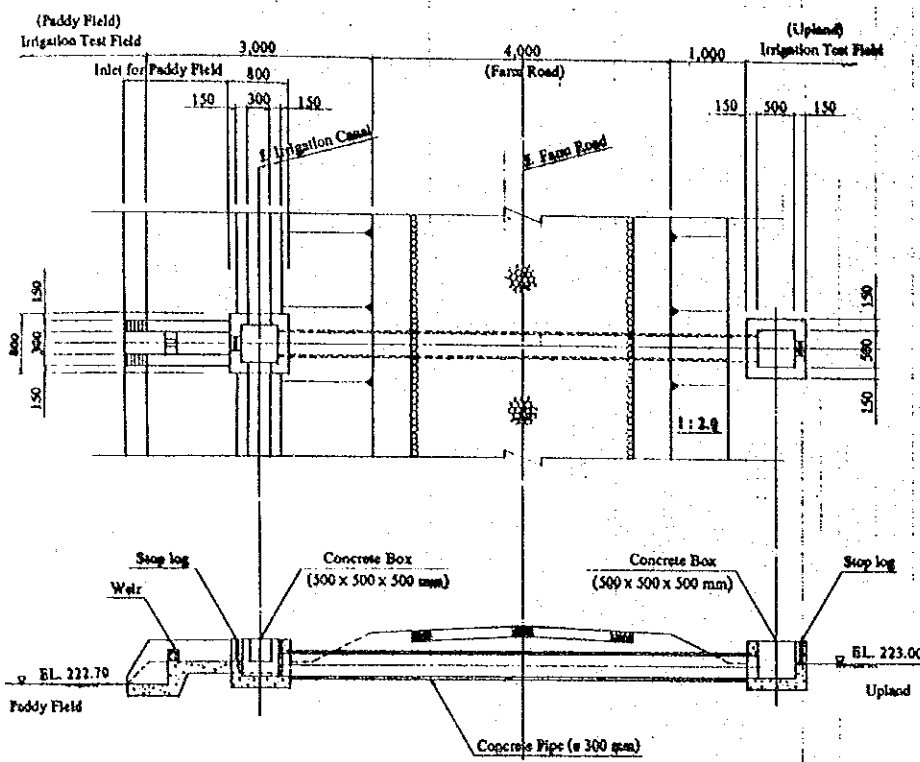

CROSSING OF FARM ROAD

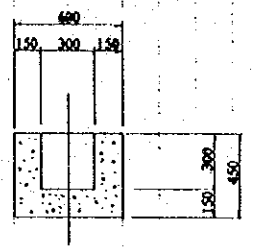

TYPICAL SECTION OF IRRIGATION CANAL

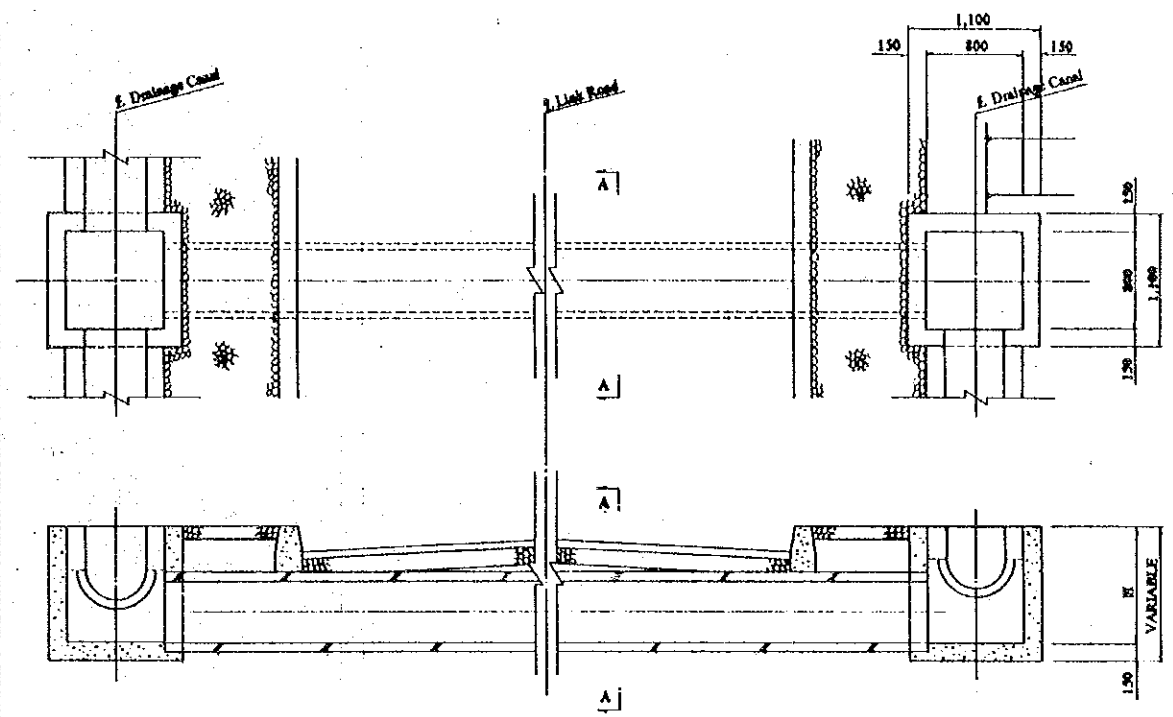

CROSSING OF LINK ROAD

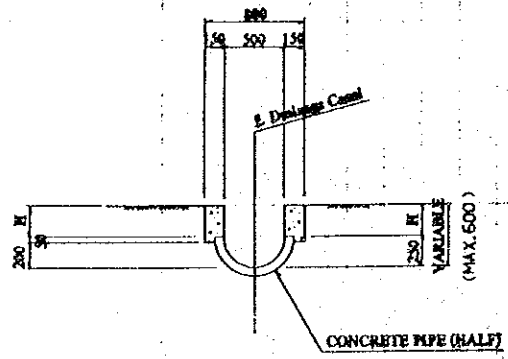

TYPICAL SECTION (U - GUTTER)

DRAINAGE CANAL

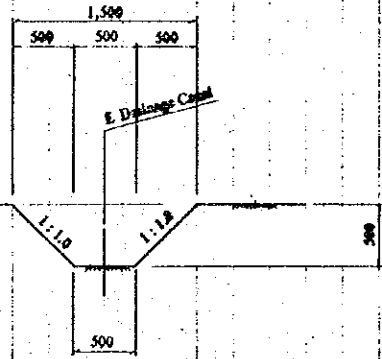

TYPICAL SECTION (OPEN DITCH)

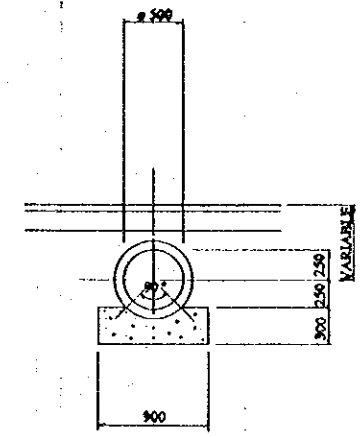

SECTION A-A (CONCRETE PIPE)

- Notes**
1. The details and elevations of facilities are subject to change and directions by the Expert.
 2. Elevation and canal slope of irrigation and drainage canal shall be given by the Expert with consideration of their functions.

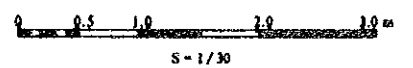

JAPAN INTERNATIONAL COOPERATION AGENCY	
THE MODEL INFRASTRUCTURE IMPROVEMENT WORKS FOR ACADEMIC DEVELOPMENT OF THE GRADUATE PROGRAM THE FACULTY OF AGRICULTURAL ENGINEERING AND TECHNOLOGY INSTITUT PERTANAHAN BOGOR	
IRRIGATION AND DRAINAGE SYSTEM	
TYPICAL SECTION OF IRRIGATION AND DRAINAGE CANAL, CROSSING OF LINK ROAD AND CROSSING OF FARM ROAD	
PREPARED BY	DRAWING NO.
CHECKED BY	7

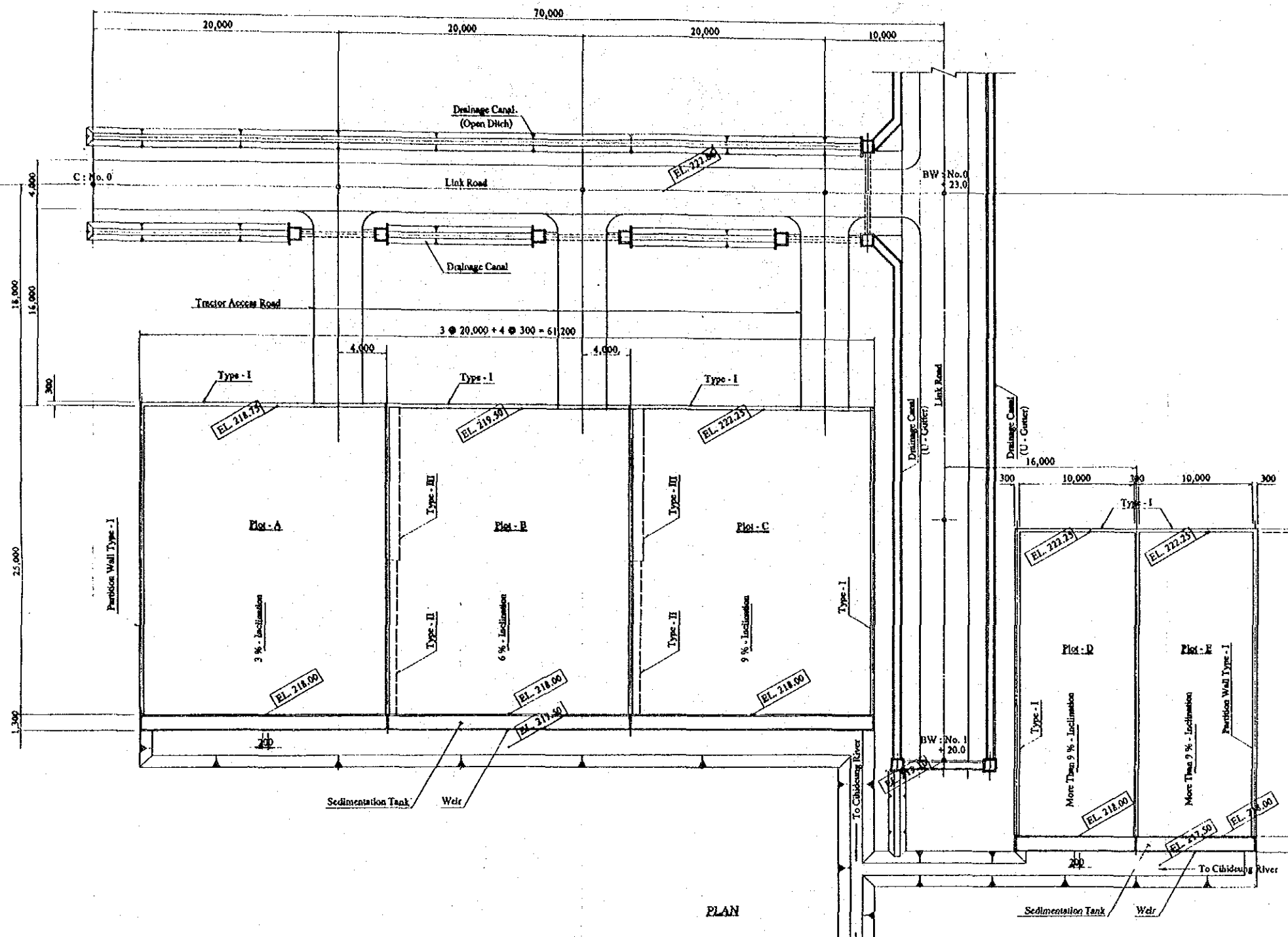

PLAN

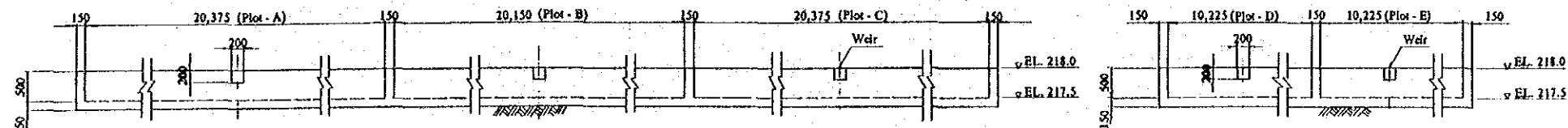

PROFILE OF SEDIMENTATION TANK

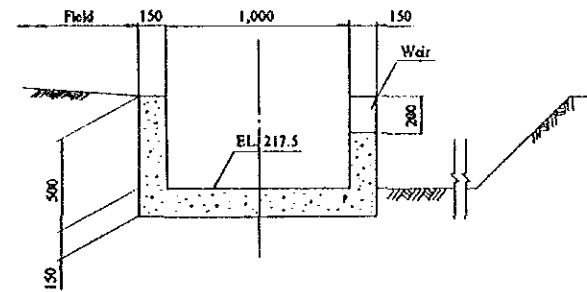
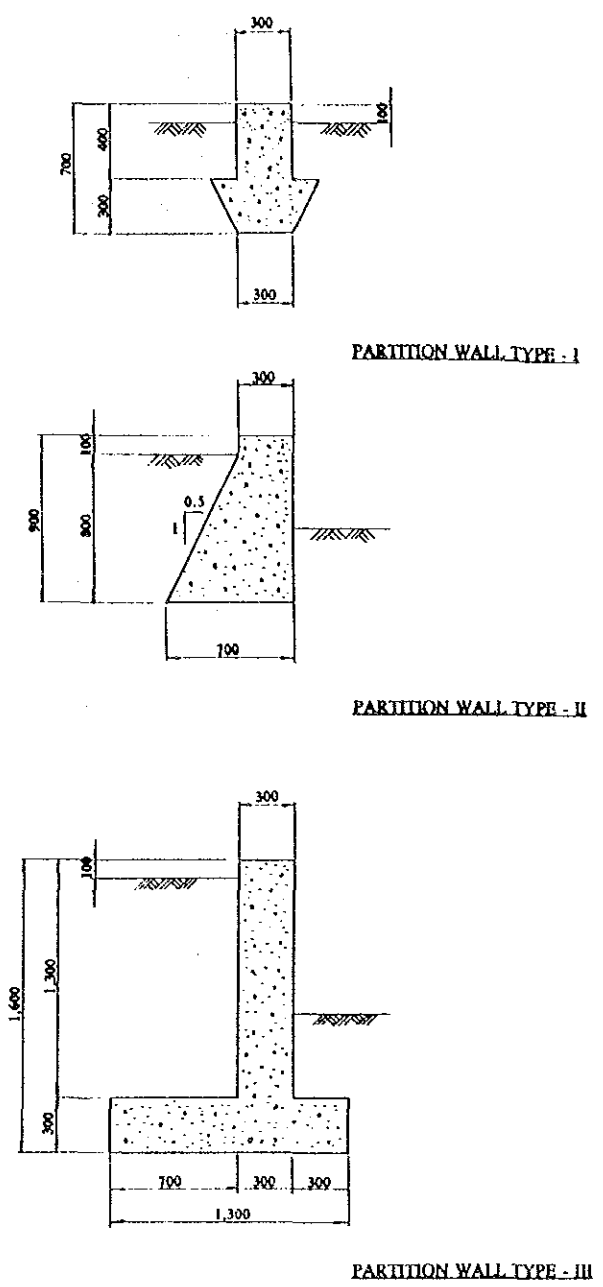

TYPICAL CROSS SECTION OF SEDIMENTATION TANK

- Notes**
- Final elevations of facilities are subject to change according to the land levelling works.
 - The details of facilities are subject to change and directions by the Expert.

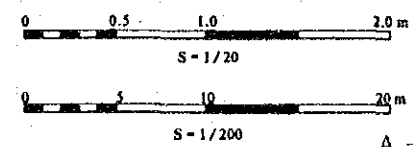

JAPAN INTERNATIONAL COOPERATION AGENCY	
THE MODEL INFRASTRUCTURE IMPROVEMENT WORKS FOR ACADEMIC DEVELOPMENT OF THE GRADUATE PROGRAM THE FACULTY OF AGRICULTURAL ENGINEERING AND TECHNOLOGY INSTITUT PERTANAHAN BOGOR	
SOIL CONSERVATION TEST FIELD	
PREPARED BY	DRAWING NO.
CHECKED BY	8

Appendix B. General Data on the Detailed Design Survey

1. Members of the Team
2. Work Schedule in Indonesia
3. Members List for Persons Concerned
4. Team Leader's Letter
5. Progress Report
6. Reporting on the Progress Report
7. Information on the Seed Technology Center

1. Members of the Team

<u>Assignment</u>	<u>Name</u>	<u>Present Position</u>
Team Leader	Prof. Hiroyasu SHIMURA	Professor, Faculty of Agriculture, University of Tokyo
Experimental Farm Planner	Mr. Masaharu MATSUI	Adviser, Nippon Giken Incorporation
Facilities Designer	Mr. Hirohiko NOZOE	Section Chief, 2nd Design Div., Technical Affairs Dept., Nippon Giken Incorporation
Coordinator	Ms. Sachiko MISUMI	Staff, Technical Cooperation Div., Agricultural Development Cooperation Dept., JICA

2. Work Schedule in Indonesia

<u>No.</u>	<u>Date/Period</u>	<u>Description</u>
1.	Jan. 7 (S)	- JICA Team arrived at Jakarta by GA 873
2.	8 (M)	- Courtesy call on Embassy of Japan, JICA
3.	9 (T)	- Courtesy call on Directorate General of Higher Education, Ministry of Education & Culture - Courtesy call on Rector of IPB, Deans of Graduate School and Fakultas Teknologi Pertanian (FATETA) - Site investigation of Experimental Farm
4.	10 (W)	- Discussion on the Basic Concept for MIIW Project with JICA Experts and Counterparts
5.	11 (T)	- Team discussion for MIIW Project - Participation to presentation on General Aspects of Water Management in Indonesia
6.	12 (F)	- Discussion on establishing Basic Plan
7.	13 (S)	- Site investigation and arrangement of surveying
8.	14 (S)	- Documentation of Basic Plan
9.	15 (M)	- Final discussion and agreement on Basic Plan with IPB Staff
10.	16 (T)	- Submitting the letter of Team Leader at Directorate of Higher Education, Commencement of topo-survey
11.	17 (W)	- Data collection and topo-survey with IPB Staff
14.	to 20 (S)	Idem
15.	21 (S)	- Data arrangement, topo-survey
16.	22 (M)	- Data collection at IHE Bandung, river survey
17.	23 (T)	- Data collection at Bogor PU, river survey
18.	24 (W)	- Submitting letter to IPB, investigation of irrigation system, river survey
19.	25 (T)	- Submitting letter to Bogor PU, topo-survey
20.	26 (F)	- Data collection at Darmaga BMG, topo-survey
21.	27 (S)	- Data collection at IHE Bandung, topo-survey
22.	28 (S)	- Data arrangement
23.	29 (M)	- Data collection at Darmaga BMG, topo-survey
24.	30 (T)	- Data collection at Bogor PU, topo-survey
25.	31 (W)	- Study of data, topo-survey
26.	Feb. 1 (T)	- Site investigation, Data collection, topo-survey
27.	2 (F)	- Data collection at Jakarta, topo-survey
28.	3 (S)	- Data collection at Bandung, topo-survey
29.	4 (S)	- Data arrangement

<u>No.</u>	<u>Date/Period</u>	<u>Description</u>
30.	5 (M)	- Data collection at Bandung, topo-survey
31.	6 (T)	- Data collection, river survey
32.	7 (W)	- Data collection at Bogor PLN, drawing of counter map, writing of Progress Report
33.	8 (T)	- Preparation of progress report, completion of topo-survey
34.	9 (F)	- Reporting and discussion on Progress Report
35.	10 (S)	- Closing working office at Darmaga Campus
36.	11 (S)	- Moving to Jakarta
37.	12 (M)	- Reporting to JICA and Embassy of Japan
38.	13 (T)	- Preparation to leave, additional data collection
39.	14 (W)	- Preparation to leave, leaving Jakarta by GA 872 (23:00)
40.	15 (T)	- Arriving at Narita (8:00)

3. Members List for Persons Concerned

3.1 IPB Staff in relation to the MIIW Project

- Prof. Dr. Sitanala Arsyad : Reactor
- Prof. Dr. Sadan Widarmana : Vice Reactor I
- Prof. Dr. Edi Guhardja : Dean of G.S.
- Dr. Kamaruddin Abdullah : Executive Secretary ADAET
- Dr. M. Aman Wirakartakusuma : Dean of FATETA
- Dr. Atjeng M. Syarief : Head Department of Agricultural Engineering
- Prof. Dr. Soerjono S. : Fac. of Forestry
- Dr. Naik Sinukaban : Fac. of Agriculture, Secretary of the Planning Board
- Dr. Moeljamo Djoyomartono : Head of Planning Study of Agricultural Engineering of the G.S.
- Dr. Soedodo Hardjoamidjoyo : Coordinator of MIIW Project
- Dr. Soleh Salahudin : Dean of Fac. of Agriculture
- Ir. Januar Jarwadi : Assistant Coordinator of MIIW Project
- Ir. Aris Priyanto MAE : Head of Soil & Water Engg. Lab.
- Ir. Frans Yusuf Daywin MSAE : Head of Farm Machinery, Lab.
- Dr. Ir. Tinneke Mandang : Coordinator JICA - DGHE/IPB Project
- Dr. Azron Dhalhar : Staff of Soil & Water Engg. Lab.
- Dr. Hadi K. Purwadaria : Head of Food & Agricultural Product Processing Engg., Lab.
- Ir. Gardjito MSc : Head of Farm Structure Lab.

3.2 JICA Experts

- Prof. Dr. Mikio Sato : Team Leader, Postharvest
- Dr. Yasuyuki Sagara : Food and Agricultural Engineering
- Dr. Seiji Sudo : Soil and Water Engineering
- Dr. Yasumasa Koga : Postharvest Technology
- Dr. Katsumi Fujii : Agricultural Engineering
- Dr. Koji Kito : Agricultural Engineering
- Dr. Kazunori Kato : Agricultural Engineering
- Mr. Kanko Yamashita : Coordinator

3.3 Government Officials

a. Indonesia

- Prof. Dr. Sukadji Ranuwihardjo : Director General of Higher Education and Culture
- Ir. Soelastri Djennoedin : Director, Institute of Hydraulic Engineering, Ministry of Public Works
- Ir. Sadeli Wiramiharja : Director of West Java Provincial Public Works
- Ir. Widodo Harjadi : Head of Water Resources, Bogor Branch Office, West Java Provincial Public Works
- Mr. B.J. Riyanto : Head of Climatological Station, Darmaga
- Mr. Hudri : Head of Planning, PLN Bogor Office

b. Japan

- Mr. Shinichi OTA : First Secretary for Education & Culture, Embassy of Japan
- Mr. Goichiro YUKAWA : First Secretary for Agriculture, Embassy of Japan
- Mr. Yasuo KITANO : Resident Representative, JICA Indonesia Office
- Mr. Toru TAGUCHI : Deputy Resident Representative, JICA Indonesia Office
- Mr. Kazuhiro YONEDA : Assistant Resident Representative, JICA Indonesia Office

4. Team Leader's Letter

JAPAN INTERNATIONAL COOPERATION AGENCY
(JICA)
DETAILED DESIGN SURVEY TEAM
FOR
THE MODEL INFRASTRUCTURE IMPROVEMENT WORKS
FOR
THE ACADEMIC DEVELOPMENT OF THE GRADUATE PROGRAM
AT THE FACULTY OF AGRICULTURAL ENGINEERING AND TECHNOLOGY
INSTITUT PERTANIAN BOGOR

January 16, 1990

Prof. Dr. Sukadji Ranuwihardjo
Director General
Directorate General of Higher Education
Ministry of Education and Culture

Dear Sir,

Re: The Model Infrastructure Improvement Works for the Academic Development of the Graduate Program at the Faculty of Agricultural Engineering and Technology, IPB.

The Detailed Design Survey Team (hereinafter referred to as "the Team") has been organized by the Japan International Cooperation Agency (JICA) for the purpose of formulating the detailed plan of the Model Infrastructure Improvement Works for the Academic Development of the Graduate Program at the Faculty of Agricultural Engineering and Technology (ADAET), I.P.B..

The Team has so far, made a series of site reconnaissances and discussions with I.P.B. staff concerned in order to determine the location and contents of the experimental farm. As the result, we would like to submit to you the basic plan for the detailed design on the experimental farm which has been agreed upon by both I.P.B. staff and the Team as the attached papers.

Two team members, Mr. MATSUI and Mr. NOZOE, will proceed with I.P.B. staff to conduct further field surveys and investigations at the site up to 14 February, 1990 in Indonesia and make the detailed design on the basis of the result of those surveys in Japan. After the completion of the detailed design and assessment of its cost estimated by JICA, you will be informed of its result through the Embassy of Japan.

For the timely commencement of the construction of the experimental farm, we would like to ask you to take the necessary formalities in due consultation with the Embassy of Japan.

Lastly, we would like to express our appreciation for the kind cooperation of you and I.P.B. staff during our stay in Indonesia.

Sincerely Yours,

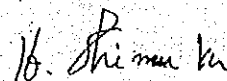

Prof. Dr. Hiroyasu SHIMURA
Team Leader
Detailed Design Survey Team
Japan International
Cooperation Agency

CC

1. I.P.B.
2. Embassy of Japan
3. JICA

ATTACHMENT

-Basic Plan-

1. Objective

The objective of the Team is to survey and design the experimental farm to be constructed by the Japanese Government based upon the Record of Discussions, Article IV signed between both Governments on December 24, 1987.

The experimental farm will be composed of fields for Agro-civil Engineering Tests and Farm Machinery Tests, which involves the construction of link roads and irrigation and drainage system etc..

The experimental farm, therefore, will be a core for activities of the technical cooperation, through the various activities mentioned in the Master Plan. (Referred to Annex 1 to this Attachment).

In light of the above, the Team conducted the surveys on the selected site, conditions of access road and water source and had preliminary discussions on the design of the experimental farm.

Consequently, the Team and I.P.B. staff had agreed on the priority of components of the experimental farm from the view point of their necessities. The detailed design will be finalized with due consideration of available budget.

2. Location and Scale

(1) The location of the experimental farm was selected at the proposed MI-(II) site in LEUWIKOPO, DARMAGA CAMPUS, I.P.B. as shown in Figs 1 and 2.

(2) The area of the experimental farm is about 2.5ha.
The experimental farm will include the following facilities listed in the order of priority.

- 1) Link roads,
- 2) Irrigation and drainage system,
- 3) Soil conservation test fields,
- 4) Irrigation test fields consist of
 - a. measurement plot
 - b. paddy field
 - c. upland fields,
- 5) Tractor test field,
- 6) Tractor test roads, and
- 7) Workshop and workstation.

3. Components of Experimental Farm

The experimental farm consists of the following facilities.

(1) Link roads

Link roads inside the experimental farm will be designed on the basis of topographic condition with consideration of the location of the experimental fields and pump station. The roads will be paved by asphalt as the existing entrance road or gravel.

(2) Irrigation and drainage system

The irrigation system consists of a pump station, a pipe line system, a farm pond, pumps and irrigation canals.

Irrigation water will be taken from the Cihideung river nearby the experimental farm. The irrigation water requires to be lifted about 20 m up to the farm pond. The size and location of the farm pond will be decided after preparation of the topographic map. Four side slopes of the farm pond will be protected by the permanent materials such as concrete or masonry. The bottom of the pond will be made of earth lining, if required.

Irrigation canals will be connected from pumps which will be installed at adequate sides along the farm pond to each irrigation test fields.

Also necessary water measurement devices will be provided in the irrigation system.

The drainage canal system will be designed on the topographic map which will be prepared by the Team. The drainage canal will be constructed with concrete and some discharge measurement devices will be provided at the necessary sites for the water balance study of the irrigation test fields.

(3) Soil conservation test fields

The soil conservation test fields consist of 4 kinds of field with dimensions as follows:

- a. 20 m width and 25 m slope length with from 0 to 3 % slope, one unit.
- b. 20 m width and 25 m slope length with from 3 to 8 % slope, one unit.
- c. 20 m width and 25 m slope length with more than 8 % slope, one unit.
- d. 10 m width and 22 m slope length with 9 % slope, two units.

The above fields will be provided with sediment and water measurement open channels and sand boxes, respectively.

The fields will be separated by the partition wall made by a permanent structure.

Slope formation will be done during the construction work. Soil moving work for experiments shall be done by I.P.B.

(4) Irrigation test fields

Irrigation test fields consist of 3 kinds of field with dimensions as follows:

- a. Measurement plot (concrete box with an observation pit) :
concrete box with 10 m width, 25 m length, 1.5 m depth;
observation pit with 10 m width, 5 m length, 3.0 m depth
one unit, respectively
- b. Paddy field : 30 m width, 100 m length, one unit with 4 inlets and outlets.
- c. Upland fields : 30 m width, 40 m and 50 m length, two units.

(5) Tractor test field

Tractor test field will be 35 m width and 80 m effective running length with 3 m head land at both ends.

(6) Tractor test roads

Tractor test roads will have three kinds of road, that is of concrete pavement, gravel metaling and earth road. If the budget is not sufficient, the priority of construction is concrete, gravel and earth in that order.

The design load of each test roads will be 8-ton tractor in total weight and the effective width is 4 m, total length is 150 m and the interval of the test road is 2 m, in parallel.

(7) Workshop and work station

In case the budget is not sufficient, only the land leveling of the site and drainage canals will be arranged.

4. Others

- (1) The Indonesian side should provide the land for the experimental farm, remove or clear the plants on the site, and safe-guard installed bench marks.
- (2) The Indonesian side will secure the right to get water from the river (about 10 litre/sec) and I.P.B. will act as a coordination body to coordinate concerned authorities.
- (3) The farm should be managed and maintained by I.P.B. after construction (ref. Annex-1 to this Attachment) and the necessary equipment, such as precise measurements for observation of the phenomena in the "measurement plot", should be installed as soon as possible.
- (4) The tentative schedule and procedure for the construction work of experimental farm is shown in table-1.
It is desirable that the construction work should be carried out during the dry season.

Bogor, January 15, 1990

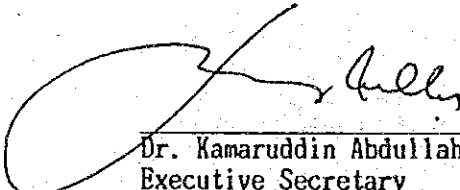

Dr. Kamaruddin Abdullah
Executive Secretary
ADAET Project-I.P.B.

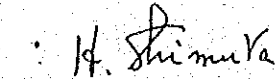

Prof. Dr. Hiroyasu SHIMURA
Team Leader
Detailed Design Survey Team,
JICA

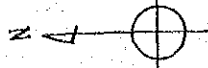

Darmaga Campus, I.P.B.

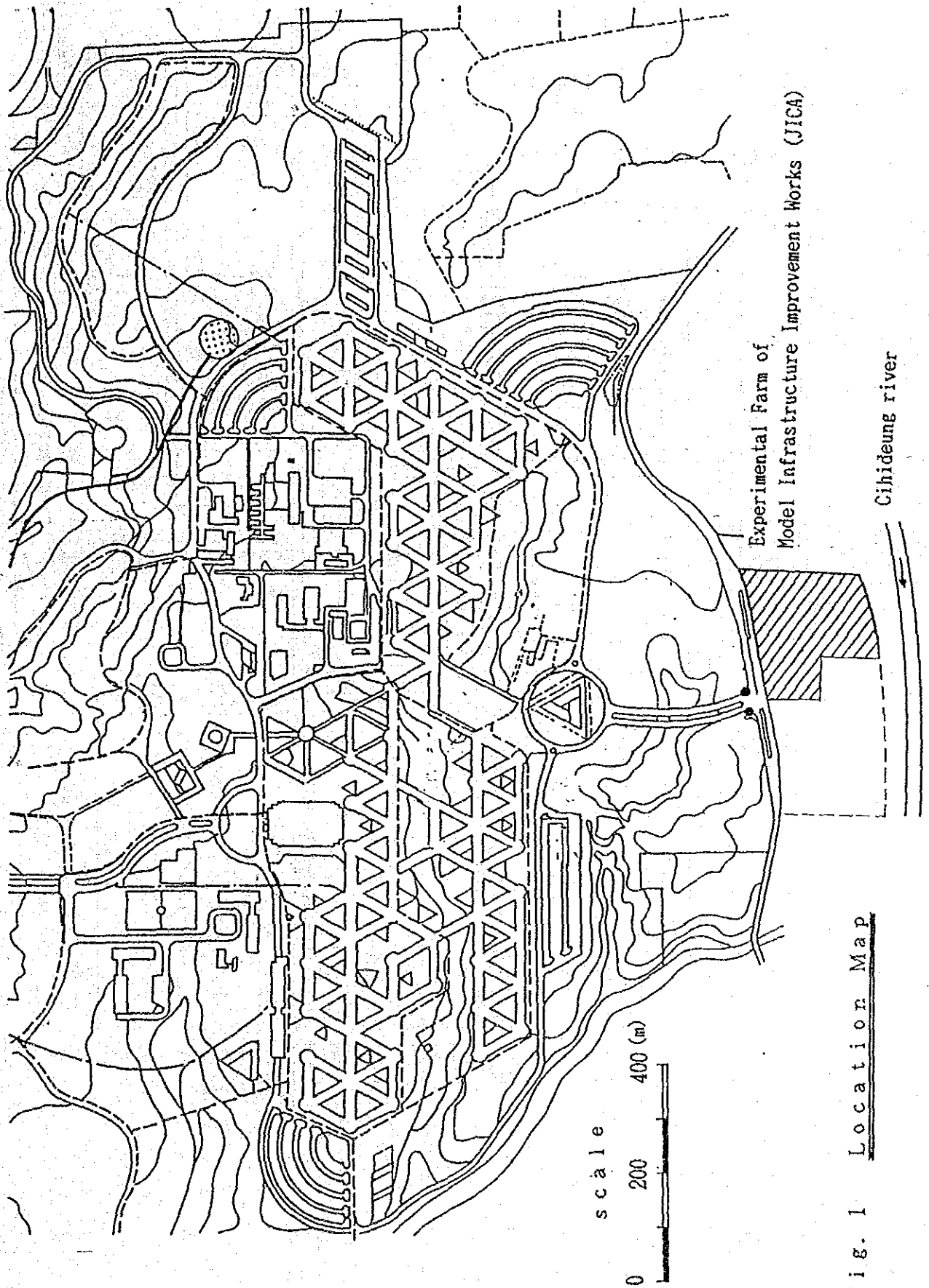

Fig. 1 Location Map

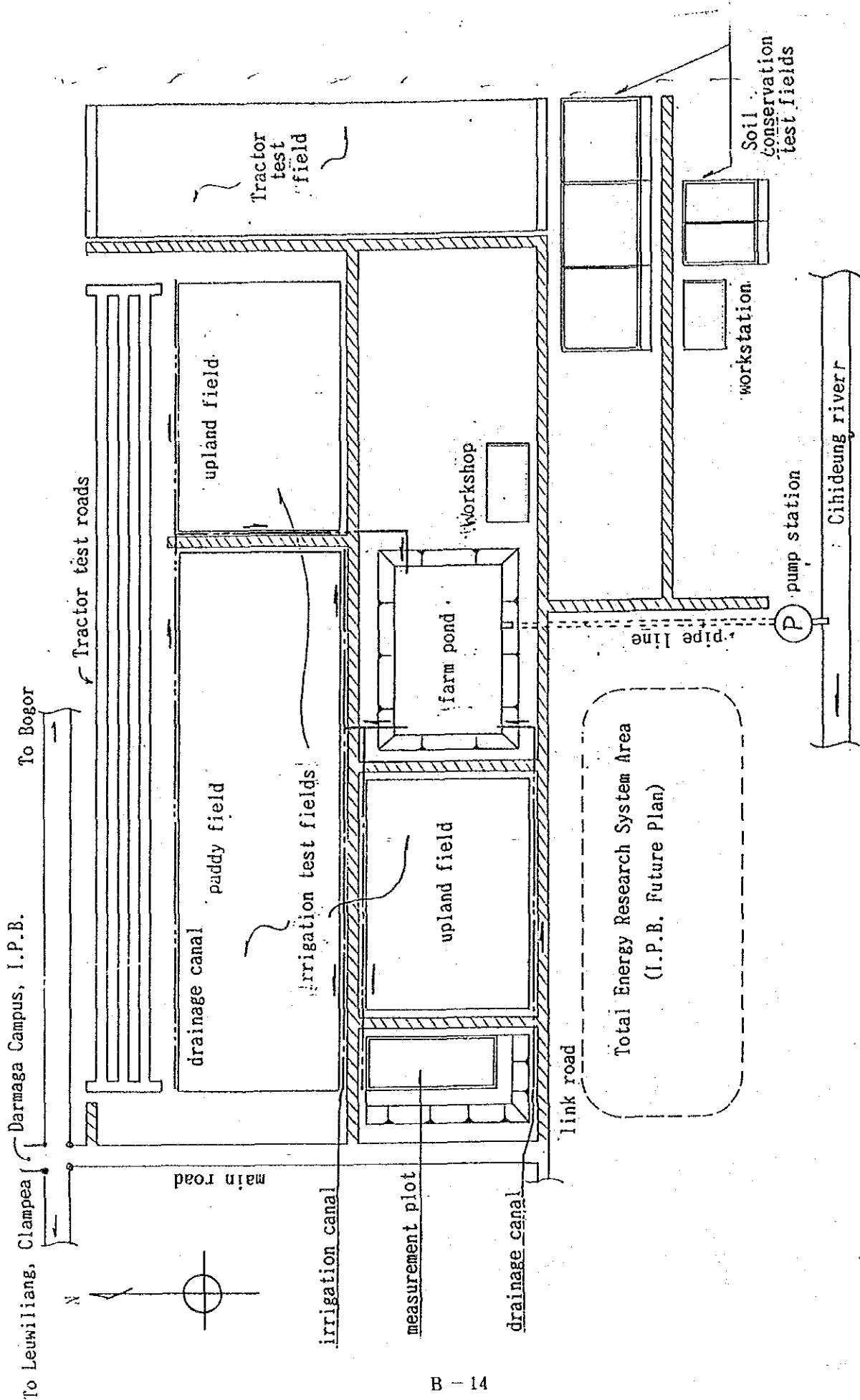

Fig. 2 Tentative Layout of Basic Plan (No scale)

OUTLINE OF THE TENTATIVE SCHEDULE
ON
THE MODEL INFRASTRUCTURE IMPROVEMENT WORK

	<u>Japanese side</u>	<u>Indonesian side</u>
1990 Jan.	Detailed design survey from Jan.7 to Feb.14	To provide land for the experimental farm
Feb.		
Mar.	Detailed design work in Japan	
Apr.	Submission of final report ----->	
		Request of construction work for the experimental farm
May.	←----- JICA HDQ	(to JICA Indonesia) and Submission of A1 form for expert(s)
Jun.		
Jul.		
Aug.		Exchange of Note of Verbal
Sep.		
Oct.	Dispatch of supervising expert(s) Remittance of budget Contract for construction	
Nov.	Start of construction work	

1. Utilization of the constructed Model Infrastructure :

As mentioned in the proposal by IPB. The main purpose of establishing a M.I. is to provide IPB with an intermediate to modern farm practice system and facilities. It is also aimed to serve as a Demonstation farm for Agricultural Engineering and Technology, as well as for :

- research facilities
- course work facilities

This M.I. is also serve as field facilities for Joint Research of ADAET Project, in wich there are 10 major topics, 4 (four) of they are closely connected/related and can make use of the M.I facilities. These four major topics of the Joint Research mentioned above are namely :

- Topics A : Optimum Utilization of Agricultural Machinery and Farm for Crop Production.
- Topic C : Labour Science and Farm-Work Science.
- Topic G : Efficient use of Irrigation in Indonesia.
- Topic H : Evaluation of Optimum Physical Condition on Farm.

2. (1) The Organization Chart for the M.I. is (proposed) as follows :

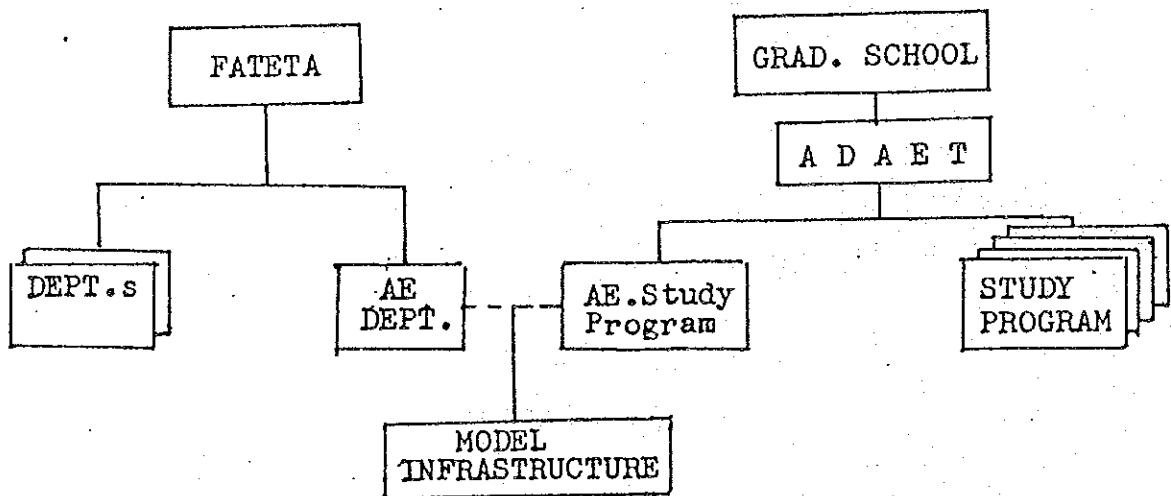

(2) Maintenance Budget (proposed) : Rp. 25 millions

(3) Manager (tentative) : Dr. Soedodo Hardjoamidjojo, MSc

5. Progress Report

PROGRESS REPORT
OF
DETAILED DESIGN SURVEY
ON
THE MODEL INFRASTRUCTURE
IMPROVEMENT WORKS
FOR
ACADEMIC DEVELOPMENT OF THE
GRADUATE PROGRAM
THE FACULTY OF AGRICULTURAL
ENGINEERING AND TECHNOLOGY
INSTITUT PERTANIAN BOGOR

February, 1990

JICA DETAILED DESIGN
SURVEY TEAM



JICA - DGHE/IPB PROJECT : JTA-9a(132)

Academic Development of the Graduate Program
The Faculty of Agricultural Engineering and Technology
Bogor Agricultural University
(Institut Pertanian Bogor)



Mailing Address :

JICA-DGHE/IPB Project
The Graduate School - IPB
P.O. Box 8, Bogor Timur,
INDONESIA

Bogor Office :

Fakultas Pascasarjana IPB
Jl. Raya Pajajaran, Bogor
Phone : (0251) 28837

Darmaga Office :

FATETA-IPB, Kampus Darmaga
Phone : (0251) 21810

9 February 1990

Prof. Dr. Sitanala Arsyad
Rector,
Institut Pertanian Bogor

Subject : Submitting of Progress Report

Dear Sir,

We are very pleased to submit herewith the Progress Report of the Detailed Design Survey on the Model Infrastructure Improvement Works for Academic Development of the Graduate Program, The Faculty of Agricultural Engineering and Technology, Institut Pertanian Bogor at the end of the field survey in Indonesia.

The field survey of the JICA Team was commenced here on 7th January, 1990, and in spite of the heavy rainy season it has been progressed very well in receiving kind assistances and valuable cooperation of IPB Staff and JICA Experts assigned at the JICA - DGHE/IPB Project. After completion of the survey the JICA Team will leave to Japan on 14th February, 1990.

We will further study the collected data in detail and engage in the Detailed Design Work for one month period in Japan. The submission of the Final Report to the Government of Indonesia is expected in April 1990.

We would like to express our heartfelt thanks to you and all the staff who have cooperated and assisted us during stay in Indonesia.

Very Truly Yours,

cc

1. Directorate General of High Education
Jakarta.
2. Embassy of Japan, Jakarta.
3. JICA, Jakarta.

Masaharu MATSUI
Experimental Farm Planner
JICA Detailed Design Survey Team
for Model Infrastructure Improvement
Works, IPB.

CONTENTS

1. General	1
2. Works Performed	1
a. Data Collection	2
b. Topographic Survey	4
3. Major Findings	5
a. Land Preparation by I.P.B.	5
b. Water Source	6
c. Electric Power	6
4. Future Schedule	7
a. Final Layout of Basic Plan	7
b. Preparation Of Final Report	...	7

ANNEX

- Annex A Members List of Detailed Design Survey Team (refer to Appendix B. 1)
- Annex B Itinerary of the Survey (refer to Appendix B. 2)
- Annex C Letter of the JICA Team Leader
 - C-1 Questionnaire
 - C-2 Basic Plan (refer to Appendix B. 4)
- Annex D Letters issued by the JICA Mission
 - D-1 Questionnaire on Existing Seed Experimental Farm, IPB, Darmaga
 - D-2 Information on Irrigation System nearby Darmaga Kampus IPB.
- Annex E Issued letters by IPB
 - E-1 Introduction letter to Institute of Hydraulic Engineering, Bandung.
 - E-2 Introduction letter to Department of Public Works, Bogor.
 - E-3 Introduction letter to Meteorological Station, Bogor.
- Annex F List of IPB Staff, JICA Experts and Government Officials who assisted the Detailed Design Survey Team. (refer to Appendix B. 3)

1. General

In response to the request from the Government of Indonesia, the Detailed Design Survey Team (hereinafter referred to as "the Team") has been organized by the Japan International Cooperation Agency (JICA) and dispatched to Indonesia on 7th January, 1990 for the purpose of formulating the detailed plan of the Model Infrastructure Improvement Works for the Academic Development of the Graduate Program at the Faculty of Agricultural Engineering and Technology, IPB. (hereinafter referred to as "the MIIW Project")

The Team has made a series of site reconnaissance and discussion with IPB staff concerned in order to determine the location and contents of the experimental farm of the MIIW Project. Resulty, the Basic Plan for the Detailed design on the experimental farm has been agreed upon by both IPB staff and the Team as given in Annex C - 2.

After establishing the Basic Plan for the MIIW Project, Prof. Dr. Hiroyasu SHIMURA (Team Leader) and Ms. Sachiko MISUMI (Coordinator) left Jakarta on 17th and 19th January, 1990, respectively.

Two Team members, Mr. MATSUI and Mr. NOZOE and one their assistant, Topographic surveyor of Nippon Giken Inc. Mr. UEDA were engaged in the remained field survey works such as site investigation, data collection and topographic survey etc. up to the end of the field survey period (8th February, 1990). After the explanation and discussion on the field survey result at IPB on the 9th February, 1990, the Team will leave Jakarta on 14th February 1990.

2. Works Performed

a. Data Collection

During the survey period the Team made much effort to collect the effective data and information for further study of the MIIW Project.

The team issued the letter of questionnaire to IPB for supply of necessary data and available information on such items as meteorological, hydrological, geological and soil conditions covering the MIIW Project area and also design criteria of the experimental farm structures on 10th January, 1990 as given in Annex C - 1.

In reply to the questionnaire, the following data have been supplied through IPB Staff :

- (1) Meteorological Data at the Klimatologi Darmaga, Bogor
6° 30' LS, 106° 45' BT, EL 249 m for 13 years (1977 through 1989)
 - (a) Daily data of Air temperature, Rainfall, Humidity, Radiation, Pan Evaporation, Pressure, and Wind velocity
 - (b) Hourly rainfall for 5 years (1985 through 1989)
- (2) Geological Map of Jawa and Madura with scale 1 : 500.000
(one copy of West Jawa Area),
- (3) Topographic Maps of 1/50.000, one copy each of no. 4323 III
Leuwiliang, no. 4323 II Bogor no. 4322 IV Gunung Salak,
no. 4322 I Tjitjiung,
- (4) One copy of Soil data prepared by Dr. Sudo at Kebun Percobaan Darmaga IV,
- (5) A Hand book for new comers to Bogor,
- (6) Kotamadya Bogor Dalam Angka Tahun 1988,
- (7) Kabupaten Bogor Dalam Angka 1988,
- (8) Reply on the utilization of the constructed facilities in connection

with research subjects,

- (9) Reply on Operation & Maintenance Plan of the Constructed Facilities,
- (10) Outline and demension of the experimental farm plot,
- (11) Master Plan Edition 1988, IPB (English),
- (12) Fact and Figures the Graduate School IPB (1975 - 1984),
- (13) Graduate School Programs 1988 - 1990,
- (14) IPB Darmaga Campus Development Project,
- (15) Jurursan Mekanisasi Pertanian Fakultas Teknologi Pertanian IPB 1989,
- (16) Outline of JICA - DGHE/IPB Project JTA - 9a (132) (Japanese)

The Team issued the letter to the Executive Secretary of IPB-JICA Project for additional questionnaire concerning to the Existing Seed Experimental Farm, Darmaga, IPB on 24th January, 1990 as given in Annex D - 1. Reply on the questionnaire is expected to receive on 9th February, 1990.

The Team has contacted to the Head of Water Resources of the Bogor Branch office, West Jawa Provincial Public Work with the introduction letter of IPB as given in Annex E - 2 and the Team's questionnaire as given in Annex D - 2.

Resulty, information of the existing irrigation systems (Cihideung, Cianyar, Cisunar, Ciherang) have been collected. Also, hydrological information at the Cihideung weir was collected.

The Team visited the Institute of Hydraulic Engineering (IHE) to collect the observed hydrological data of the Cihideung river with introduction letter of IPB as given in Annex E - 1.

However, it is not available because it is not included in the hydrological observation network of IHE.

The Team visited the West Java Provincial Public Works and collected the data on basic prices of construction materials and labor wages in Bogor, Cianjur and Sukabumi area in 1989.

The following data collected at the Book Shop of the Ministry of Public Works, Jakarta.

- (1) Manual Pemeriksaan Bahan Jalan
- (2) Daftar Harga Satuan Pekerjaan (unit price) di Indonesia (1989/1990)
- (3) Patokan Harga Satuan Pekerjaan Bidang Pemborongan Pemerintah DKI Jakarta, October 1989.

Soil sample at the test pit in the proposed experimental farm area was taken up and the test of soil physical characteristics determination was made at the laboratory of the Department of Agricultural Engineering, IPB. Data were obtained on 3rd February, 1990.

b. Topographic Survey

The preparation of the detailed topographic map with contour line of one meter is one of the important objectives of our field survey of the experimental farm. So that the Team concentrated his efforts to carry out the topographic survey within a given period. Overcoming heavy rain weather condition the topographic survey was completed on

time. Tentative drawing of the contour map has been examined by using an assumed elevation of the temporary bench mark. Afterward, the established bench mark for the construction of the Darmaga Campus Area, was found at the end corner of the entrance road, therefore, our temporary benchmark was connected to the Darmaga bench mark by leveling survey.

Now we are looking for the accurate elevation of the bench mark for the construction of the Darmaga Campus Area.

River survey of the Cihideung river which is running along the foot of the proposed experimental farm hill was carried out for some extent. Those results will be used for the determination of the location of the irrigation pump station.

3. Major Findings

a. Land preparation by IPB

The proposed area of the experimental farm is now fully utilized by the Politechnical Horticultural Course of IPB, and many Coconut Trees more than 150 and other grafting trees are growing on the land. Also small buildings are constructed.

The official agreement inside IPB to convert the land use to the experimental farm of the agricultural engineering IPB shall be made and the land shall be secured for the implementation of the MIIW Project. It is requisite condition to receive a grant aid of the Government of Japan. No compensation cost of the site is included in the Project cost of the grant aid program of Japan.

b. Water Source

It has been considered that the irrigation water source of the experimental farm shall be depending on the Cihideung river at the foot of the experimental farm hill. About 10 liters per second of the Cihideung river water may be required to lift from a pump station.

It is suggested that IPB should ask to the Governor of the West Java Province the permission of water right to take the Cihideung river water.

With the documents after completion of the Final Report such request shall be made in consultation with the head of water resources, Bogor branch office, West Java Provincial Public Works.

c. Electric Power

It was found that the transformer with capacity of 160 KVA and 66 KVA panel meter have been installed at the western corner of the seed farm.

As for electric power supply to the experimental farm of agricultural engineering, those facilities may be co-used. If the demand of the electricity of the MIIW Project is estimated to be less than $160-66=94$ KVA in total, the additional installation of one panel meter and the concerned transmission line from the existing transformer may be economic.

Those electric works shall be undertaken by PLN, therefore, the further investigation by PLN Staff shall be invited after completion of the Final Report

4. Future Schedule

a. Final layout of Basic Plan

The tentative layout of the basic plan has been presented in the letter of the Team Leader as given in Annex C - 2.

It will be studied more deep on the newly prepared topographic counter map and finalized for location of each component of the experimental farm, in Japan.

b. Preparation of Final Report

All the collected data and information will be studied for one month period in Japan and the Final Report including tender documents will be submitted through JICA to the Government of Japan in April, 1990.

10 January 1990

Dr. Kamaruddin Abdullah
Vice Dean I of Doctor Program

We would like to submit our questionnaire for Detailed Design work of the Model Infrastructure of IPB as attached papers.

Your kind arrangement on the questionnaire will be much appreciated.

Sincerely Yours,



Dr. Hiroyasu SHIMURA,
JICA mission leader.

QUESTIONNAIRE

A. DATA COLLECTION

1. Daily rainfall data of the following observation station for at least past 20 yrs.
 1. Bogor empang 6 36's 106 47'E 240 m
 2. Atangsanjaya/Bogor 6 38's 106 54'E
 3. IPB
2. Hourly rainfall data of the above stations for available period.
3. Meteorological data at least 10 years.
 1. Daily air temperature
 2. Relative humidity
 3. Wind Velocity
 4. Duration of sunshine
 5. evapotranspiration
4. Hydrological data.
 1. Observation records of water stage and discharge (Cihideung river).
 2. Water quality (ex. Electric conductivity).
5. Geological data (Project site).
 1. Geological information.
 2. Historic record of earthquakes.
6. Soil (Project site)
 1. Soil classification.
 2. Soil property.
 3. California Bearing Ratio (C.B.R. Value).
 4. Dutch corn value.
 5. Permeability soil depth.
 6. Effective soil depth.
 7. Water holding capacity.
7. General information of Bogor city
8. Topographic map covering IPB area and catchment area of Cihideung river with scale of 1 : 25,000 or 1 : 50,000.

B. QUESTIONNAIRE

1. Explanation on the utilization of the constructed facilities in connection with research subjects.

2. Operation and maintenance plan of the constructed facilities.
 - (1) Organization chart.
 - (2) Budget.
 - (3) Manager

3. Design criteria
 - (1) Experimental plots for irrigation and drainage.
 - i. Crop.
 - ii. Irrigation method.
 - iii. Water requirement.
 - iv. Water Source.
 - v. Irrigation and drainage system.
 - vi. Plot size.

 - (2) Soil conservation and erosion test plots.
 - i. Plot size and structural requirements.
 - ii. Soil property and slope in the plot.
 - iii. Measurement system of erosion.

 - (3) Test road for tractors.
 - i. Width, Length, and Slope.

 - (4) Building for irrigation and erosion laboratory.
 - i. Size.
 - ii. Structural material.

 - (5) Road networks.
 - i. Width.
 - ii. Structure.

 - (6) Building for agricultural machine.
 - i. Size.
 - ii. Structure.

 - (7) Cost information
 - i. Unit cost (Material cost and Wage).
 - ii. Latest construction cost of the similar works by local contractor.

 - (8) Farm Power requirement.



ANNEX D-1 JICA - DGHE/IPB PROJECT : JTA-9a(132)

Academic Development of the Graduate Program
The Faculty of Agricultural Engineering and Technology
Bogor Agricultural University
(Institut Pertanian Bogor)



Mailing Address :

JICA-DGHE/IPB Project
The Graduate School - IPB
P.O. Box 8, Bogor Timur,
INDONESIA

Bogor Office :

Fakultas Pascasarjana IPB
Jl. Raya Pajajaran, Bogor
Phone : (0251) 28837

Darmaga Office :

FATETA-IPB, Kampus Darmaga
Phone : (0251) 21810

January, 24. 1990

Dr. Kamaruddin A.
Executive Secretary of
IPB - JICA Project

Subject : Questionnaire on Existing Seed
Experimental Farm, Darmaga, IPB.

Dear Dr. Kamaruddin A.

We would like to request you to supply the following information on the Existing Seed Experimental Farm, Darmaga, IPB for our study on the Model infrastructure Improvement Works which will be implemented at the East side of the the Seed Experimental Farm :

1. Size of the Farm and Boundary of the farm, if available drawings of the plan of the facilities.
2. Objectives of the Farm
3. Management, organization and budget of the Farm
4. Provided facilities
 - a. Electricity (Voltage, current, capacity, unit price, etc)
 - b. Water supply (Depth. of well, pump capacity, size and length of pipe line)
 - c. Designed Drawings, Specification and Construction cost of Road, Farm, and Buildings
 - d. Physical Feature of Soils of the Farm
 - a. Top Soil
 - b. Sub Soil
 - c. Foundation (Soil analysis data obtained from well digging)
5. Information on the present land use of the Proposed Model Infrastructure Improvement Works Area
 - a. Management by Polytechnical Agriculture Course
 - b. Present land use plan and Existing soil data and crops
 - c. Agreement inside IPB on the conversion of the area to the future Agriculture Engineering Experiment Farm



JICA - DGHE/IPB PROJECT : JTA-9a(132)

Academic Development of the Graduate Program
The Faculty of Agricultural Engineering and Technology
Bogor Agricultural University
(Institut Pertanian Bogor)



Mailing Address :

JICA-DGHE/IPB Project
The Graduate School - IPB
P.O. Box 8, Bogor Timur,
INDONESIA

Bogor Office :

Fakultas Pascasarjana IPB
Jl. Raya Pajajaran, Bogor
Phone : (0251) 28837

Darmaga Office :

FATETA-IPB, Kampus Darmaga
Phone : (0251) 21810

d. Others, if any

Your kind arrangement of the above within one week will be highly appreciated.

Very Truly Yours

Masaharu MATSUI

Detailed Design Survey Team
for MIIW of IPB.



terima,
24/1/90



JICA - DGHE/IPB PROJECT : JTA-9a(132)

Academic Development of the Graduate Program
The Faculty of Agricultural Engineering and Technology
Bogor Agricultural University
(Institut Pertanian Bogor)



Mailing Address :

JICA-DGHE/IPB Project
The Graduate School - IPB
P.O. Box 8, Bogor Timur,
INDONESIA

Bogor Office :

Fakultas Pascasarjana IPB
Jl. Raya Pajajaran, Bogor
Phone : (0251) 28837

Darmaga Office :

FATETA-IPB, Kampus Darmaga
Phone : (0251) 21810

January, 25, 1990

Ir. Widodo
Head of Water Resources
Bogor Branch Office
West Java Public Works

Subject : Information on Irrigation System
nearby Darmaga Kampus, IPB.

Dear Sir,

We would like to ask your kindness to supply the following information for our study on the Model Infrastructure Improvement Works of the Agricultural Experiment Farm which will be implemented by a grant aid of the Government of Japan in the Fiscal year of 1990 :

1. Irrigation systems of which water resources are depending on the Cihideung in the upstream and downstream seed experimental farm of Darmaga Kampus, IPB.
 - a. Location of head works and irrigation canals shown on a map
 - b. Irrigation block area with scheme drawing
 - c. Structure of the head works
 - 1) Type, width, length, height, designed flood in m³/sec and over flow depth of diversion dam
 - 2) Intake Capacity
 - d. Structure of Pump
 - 1) Type and size of pump
 - 2) Capacity
 - 3) Power required
 - e. Irrigation Canals (Dimension and length of Main and Secondary Canals and their capacity)
 - f. Constructed Time of the System
 - g. Construction Cost of the System
 - h. Operation and Maintenance Cost of the System
2. Irrigation System of the Sawah Baru on the Cibenteng by which Experimental Farm of IPB are being irrigated :
 - a. Location of headwork and irrigation canals shown on a map
 - b. Irrigation block area with scheme drawing
 - c. Structure of the head works
 - 1) Type, width, length, height, designed flood in m³/sec and over flow depth of diversion dam
 - 2) Intake Capacity
 - d. Irrigation Canals (Dimension and length including flow capacity of main and secondary canals)
 - e. Construction Time of the System
 - f. Construction Cost of the System
 - g. Operation and Maintenance Cost of the System
 - h. Decided Capacity to the Existing Experimental Farm of Darmaga Kampus IPB for irrigation water distribution.



JICA - DGHE/IPB PROJECT: JTA-9a(132)

Academic Development of the Graduate Program
The Faculty of Agricultural Engineering and Technology
Bogor Agricultural University
(Institut Pertanian Bogor)



Mailing Address :
JICA-DGHE/IPB Project
The Graduate School - IPB
P.O. Box 8, Bogor Timur,
INDONESIA

Bogor Office :
Fakultas Pascasarjana IPB
Jl. Raya Pajajaran, Bogor
Phone : (0251) 28837

Darmaga Office :
FATETA-IPB, Kampus Darmaga
Phone : (0251) 21810

3. Catchment area and its vegetation feature and Runoff and sediment records of Cihideung, Cibenteng, and Cisadane by DPU or IHE, Bandung.
4. Daily rainfall records in or nearby Bogor Area
5. Copies of Topographic map with scale of 1/10000, 1/50000, 1/25000, if any.
6. Basic prices and unit prices of earth works, masonry works, concrete works, etc. of the Construction of civil engineering works for reference to estimate construction cost.
7. Compensation Price of trees and crops for DPU Construct works

Your kind arrangement on the above matters within one week will be highly appreciated.

Very Truly Yours

Masaharu MATSUI
Detailed Design Survey Team
for MIIW of IPB.



ANNEX E-1

DEPARTEMEN PENDIDIKAN DAN KEBUDAYAAN
FAKULTAS PASCASARJANA
INSTITUT PERTANIAN BOGOR

Jalan Raya Pajajaran, Bogor 16144 Telp. 28837/26881

Bila menjawab Surat ini sebutkan Tanggal dan Nomor

19 JAN 1990

No. : 303/PT 89. H. PPSIPN/90

Lampiran :

Hal : KUESTIONER

Kepada : Yth. Kepala

IHE, PU

di Bandung

Dalam rangka pengumpulan data untuk pembuatan lapangan Percobaan IPB di Darmaga bersama ini kami mohonkan agar dapat diberikan data yang berhubungan dengan instansi Saudara seperti tercantum dalam kuestioner terlampir.

Atas kerjasamanya diucapkan terima kasih.



Dekan I:

Dr. Hamaruddin Abdullah

130 676 733



ANNEX E-2

DEPARTEMEN PENDIDIKAN DAN KEBUDAYAAN
FAKULTAS PASCASARJANA
INSTITUT PERTANIAN BOGOR

Jalan Raya Pajajaran, Bogor 16144 Telp. 28837/26881

Bila menjawab Surat ini sebutkan Tanggal dan Nomornya.

19 JAN 1990

No. : 303/PT39-HS.FPSIP/W/90

Lampiran :

Hal : KUESTIONER

Kepada : Yth. Kepala
Kantor Departemen Pekerjaan Umum
Cabang Bogor
di
Bogor

Dalam rangka pengumpulan data untuk pembuatan lapangan Percobaan IPB di Darmaga bersama ini kami mohonkan agar dapat diberikan data yang berhubungan dengan instansi Saudara seperti tercantum dalam kuestioner terlampir.

Atas kerjasamanya diucapkan terima kasih.

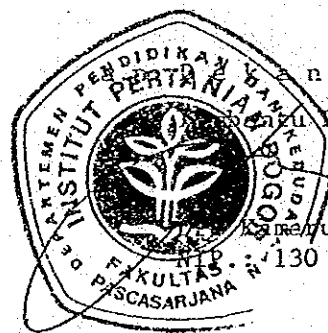

Dekan I

Samududin Abdullah

NIP. 130 676 733



DEPARTEMEN PENDIDIKAN DAN KEBUDAYAAN
ANNEX E -3 **FAKULTAS PASCASARJANA**
INSTITUT PERTANIAN BOGOR
Jalan Raya Pajajaran, Bogor 16144 Telp. 28837/26881

Bila menjawab Surat ini sebutkan Tanggal dan Nomornya

19 JAN 1990

No. : 303/PTB9.15.FPSIP/90

Lampiran :

Hal : KUESTIONER

Kepada : Yth. Kepala
Stasiun Cuaca
di
Bogor

Dalam rangka pengumpulan data untuk pembuatan lapangan Percobaan IPB di Darmaga bersama ini kami mohonkan agar dapat diberikan data yang berhubungan dengan instansi Saudara seperti tercantum dalam kuestioner terlampir.

Atas kerjasamanya diucapkan terima kasih.



Dekan I:

Dr. Hamaruddin Abdullah

130 676 733

6. Reporting on the Progress Report



JICA - DGHE/IPB PROJECT ; JTA-9a(132)

Academic Development of the Graduate Program
The Faculty of Agricultural Engineering and Technology
Bogor Agricultural University
(Institut Pertanian Bogor)



Mailing Address :

JICA-DGHE/IPB Project
The Graduate School - IPB
P.O. Box 8, Bogor Timur,
INDONESIA

Bogor Office :

Fakultas Pascasarjana IPB
Jl. Raya Pajajaran, Bogor
Phone : (0251) 28837

Darmaga Office :

FATETA-IPB, Kampus Darmaga
Phone : (0251) 21810

10. February, 1990

Dr. Kamaruddin A.
Executive Secretary of
JICA - IPB Project

through

Dr. Soedodo Hardjoamidjoyo
Coordinator MIIW Project

Subject : Progress Report on the MIIW Project

Dear Dr. Kamaruddin A.

We are very pleased to inform you that we have submitted thirty copies of the Progress Report to the coordinator of the MIIW Project, Dr. Soedodo H. at the meeting room of the Darmaga Campus on 9th February, 1990 for distribution to the IPB Staff and JICA Experts concerned to the MIIW Project.

In the meeting, we also disclosed our idea on the modification of the tentative layout of the Basic Plan based on the newly prepared topographic maps by us for discussion and exchange of views. As the result, the idea was accepted in principle by all attendants.

We, however, will further study the idea more detail in Japan and decide final layout with approval of our Team Leader :
Prof. Dr. Hiroyasu SHIMURA.

At the end of the meeting we are requested from IPB Staff that one copy of the draft map in which the idea is shown shall be granted for their further consideration and reference

So we enclosed herewith the following materials for your use :

1. Two progress reports
2. Two draft maps on which our idea is shown
3. One draft map on which site photographs are patched, and
4. Two draft maps on which the boundary of energy system development area is shown

We would like to express our gratitude to you for your kind

arrangement and assistance given to us during our stay in Indonesia.

Very truly yours,



Masaharu MATSUI

Experimental Farm Planner

JICA Detailed Design

Survey Team for Model

Infrastructure Improvement

Works, IPB.

Acknowledged

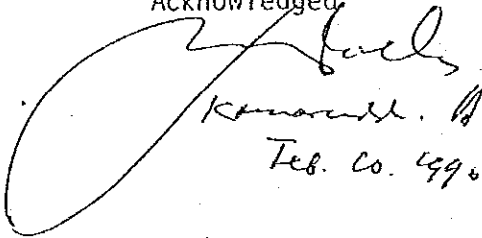

Komandi. A
Feb. 20. 1994

7. Information on the Seed Technology Center

To:

Bogor, March 24, 1990.

Mr. Masaharu MATSUI
Adviser,
NIPPON GIKEN INCORPORATION
JAPAN.

Dear Mr. Matsui,

Enclosed you will find some brief information on Seed Technology Center, IPB, the Center that is located in Leuwikopo, Darmaga, Bogor.

I am very sorry that this information was very late from our last meetings. It is also very unfortunate that the information was not as complete as we expected. This is because the Center was financed by the Ministry of Agriculture, not by the Ministry of Education and Culture/IPB.

Anyway, I hope that this will not be an obstacle for our Model Infrastructure Project. I hope to hearing from you about the progress of the Project very soon.

Sincerely yours,

Soedodo Hardjoamidjojo
FATETA IPB, P.O.Box 122
Bogor, Indonesia.

INFORMATION ON SEED TECHNOLOGY CENTER

1. Objectives of the center:

- Education
- Research
- Seed Industry : jointly cooperated with the surrounding farmers

2. Management : the center is managed by The Department of Agronomy, Faculty of Agriculture, IPB in Seed Industry Teaching Program. The Organization structure is attached.

3. Budget : the yearly budget for the Center is composed of two parts, i.e. :

- a. for maintenance in the amount of Rp.6 000 000,-
- b. for education in the amount of Rp.2 000 000,-

(these budgets do not include electricity and research).

4. Facilities :

- a. Electricity: - 220 Volt, 3 phase, 60 KVA supplied by State Electricity Company (PLN)
- 2 units, 25 KVA/unit generator set
- b. Water supply: - pumped from 4 wells, 15 m depth,
4 electric pump units, 500 W/unit.

5. Present Land Use: the present Land Use of the area proposed for the Model Infrastructure are:

- a. part that is managed by Polytechnics Agricultural Course (PLPT), planted with Coconut and Coffea;
- b. part that is managed by Seed Technology Center, planted with low land vegetatable crops.

6. Use of the area for Model Infrastructure : The Rector of IPB has orally agreed that the area mentioned above can be used for Agricultural Engineering Experimental Farm / Model Infrastructure Works Area, but the written agreement is still under process.

7. Size and Boundary of the farm : attached.

8. Designed drawings and Specification : not available.

ORGANIZATION STRUCTURE OF SEED TECHNOLOGY
CENTRE

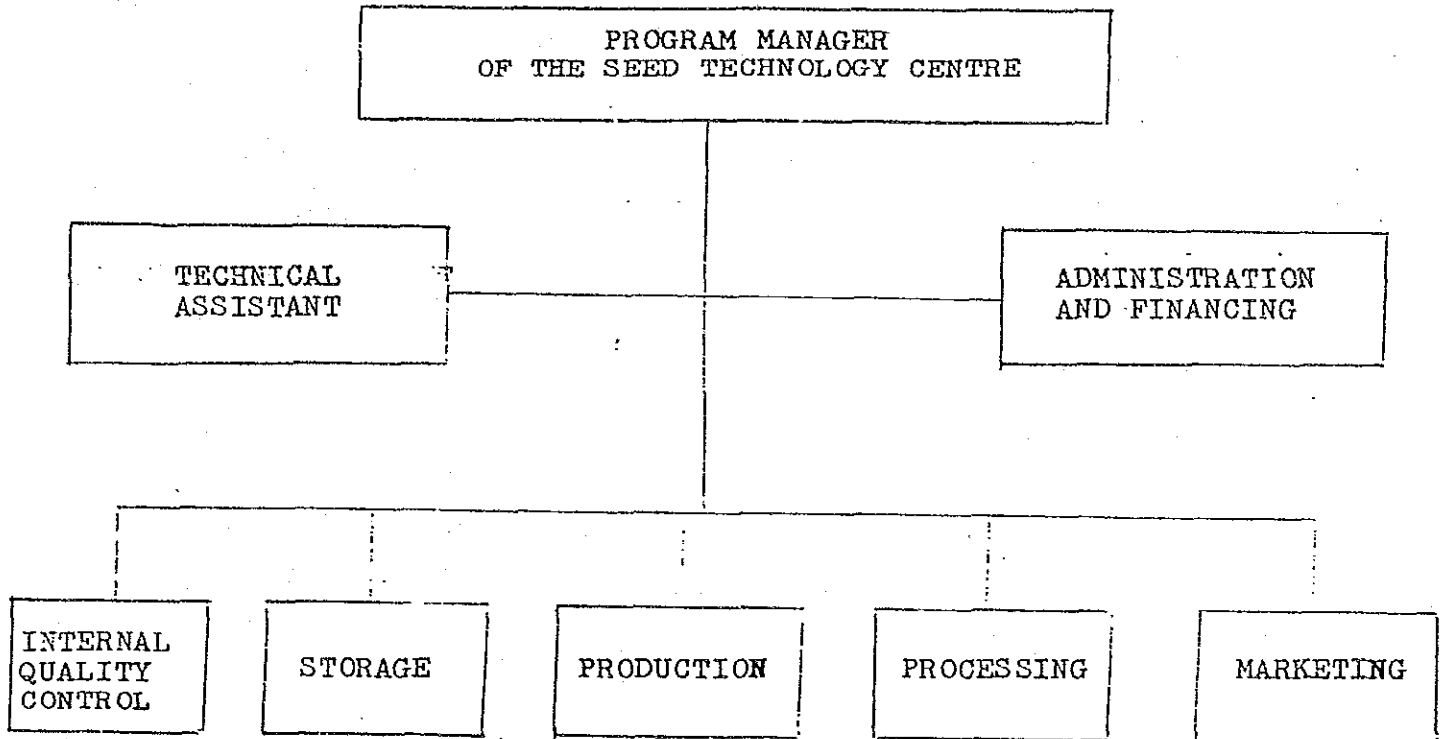

THE SEED TECHNOLOGY CENTRE

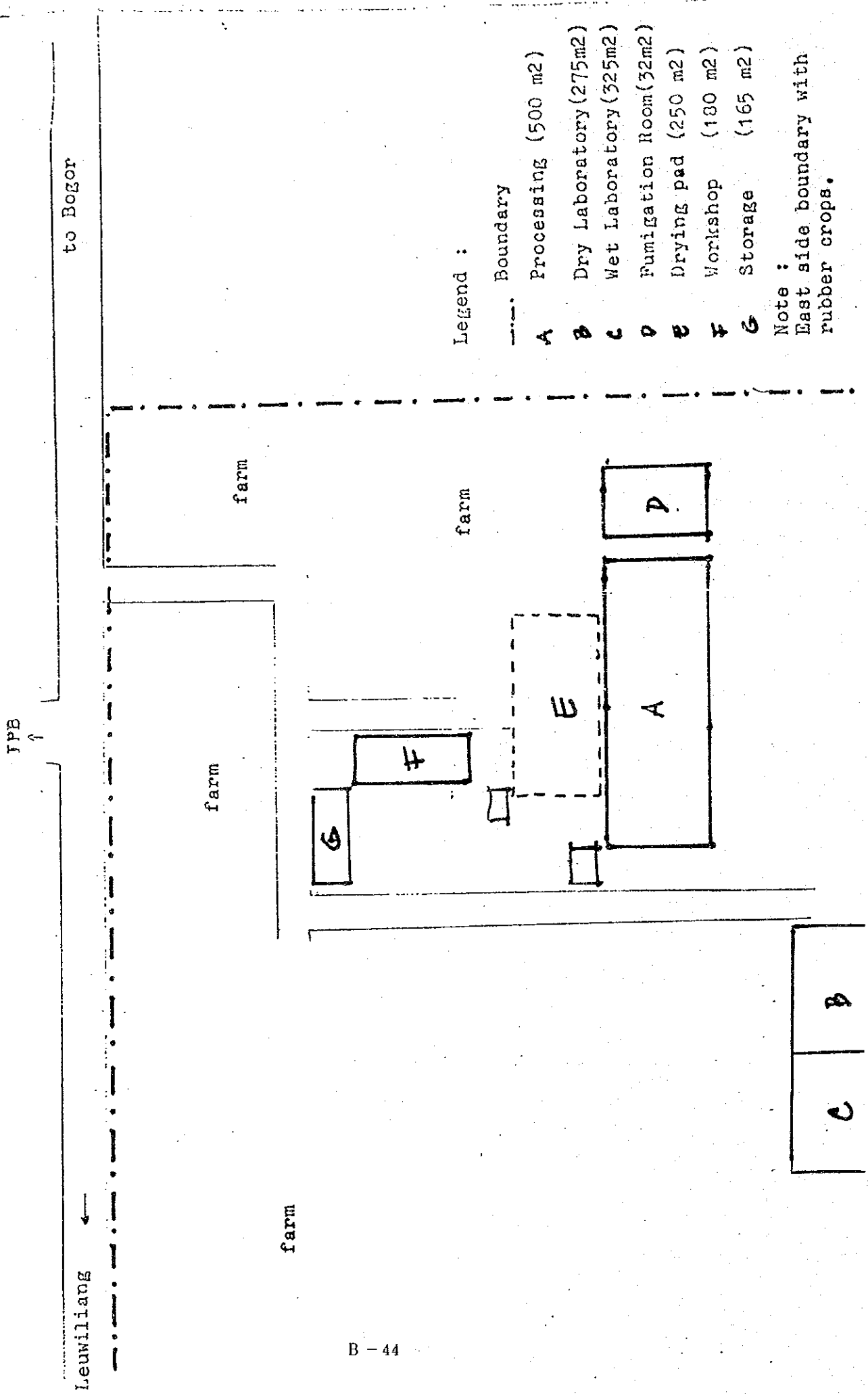

Legend :

- Boundary
- A Processing (500 m²)
- B Dry Laboratory (275m²)
- C Wet Laboratory (325m²)
- D Fumigation Room (32m²)
- E Drying pad (250 m²)
- F Workshop (180 m²)
- G Storage (165 m²)

Note :
East side boundary with rubber crops.

Appendix 3:

THE COST OF SEED TECHNOLOGY CENTER

1. Building construction	Rp. 200 450 000,-
2. Equipment	Rp. 57 350 000,-
3. Scholarships	Rp. 82 500 000,-
4. Training	Rp. 185 885 000,-
5. Consultants	US\$. 250 000,-
6. Miscellaneous	Rp. 20 000 000,-

Managed by PLPT
(Polytechnical Agriculture Course)

Crops : - Coconut
 - Coffee

Managed by
Seed Technology Centre
(for low land vege-
table crops)

Crops : - Longbeam
 - Water spinach
 - Spinach
 - Chilli
 - Tomatto
 - Sesami

East boundary of the seed centre
by rubber crops.

Cihideung rivers

JICA