

PLANE (A-LINE IRRIGATION CANAL) SCALE . A

PLANE (B-LINE IRRIGATION CANAL) SCALE . A

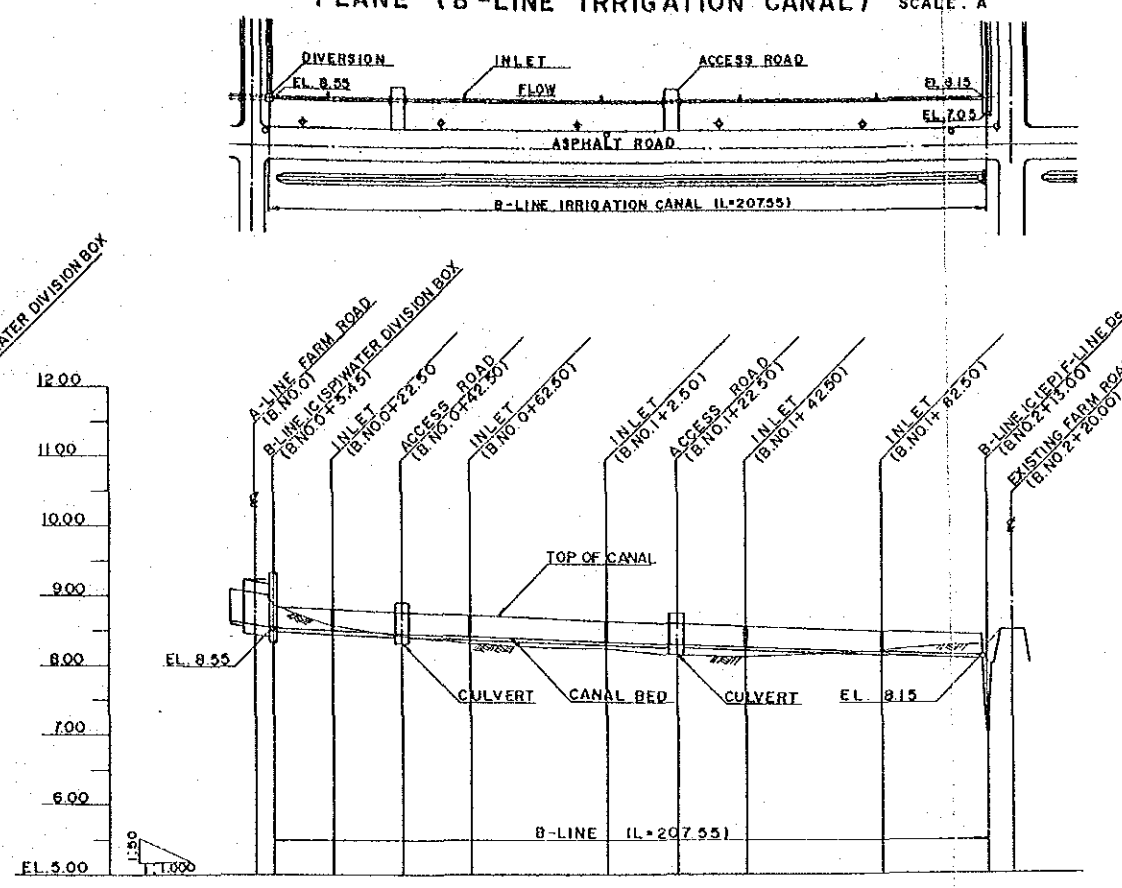
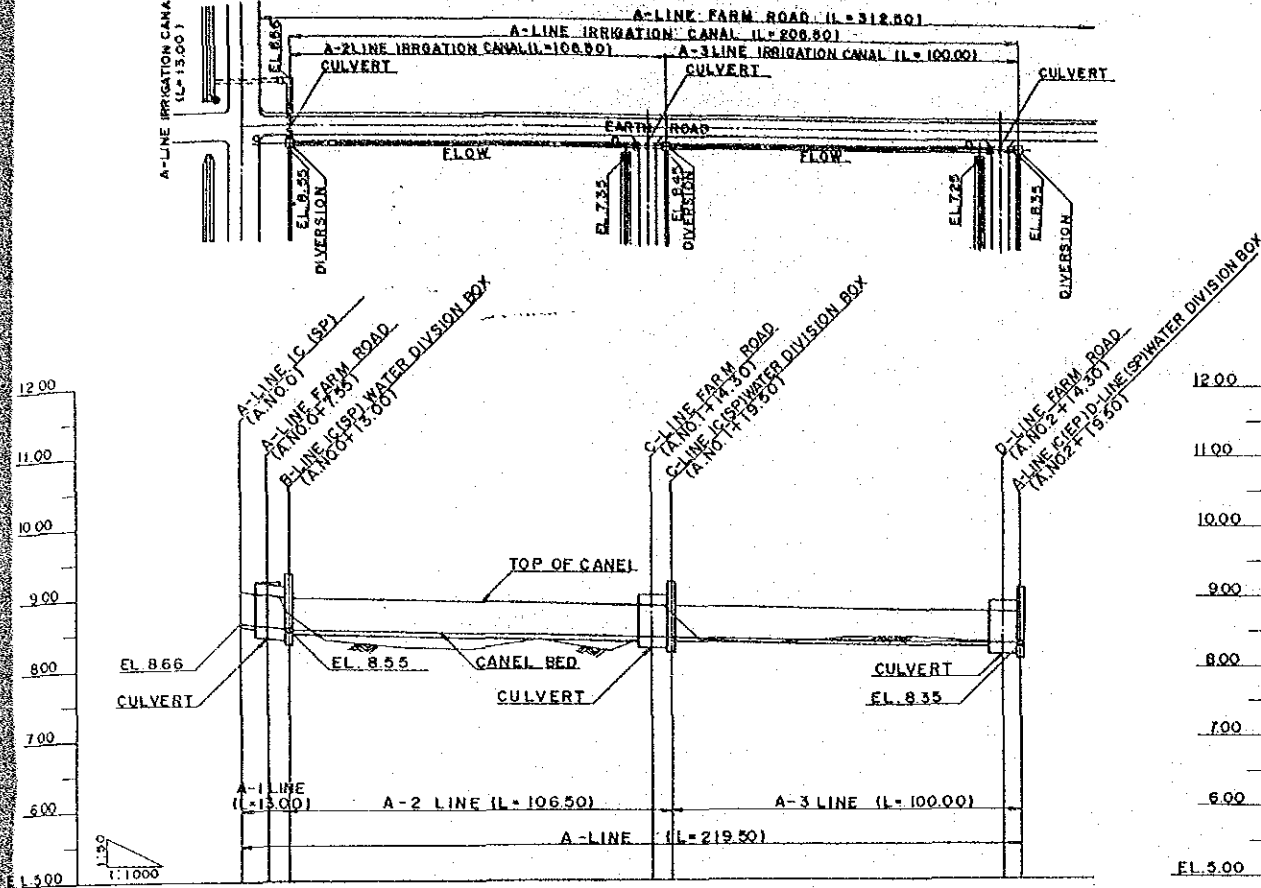

ELEVATION	SLOPE	
	6.62	6.35
WATER SURFACE		
WATER DEPTH		
CANAL BED	8.65	8.35
GROUND ELEVATION	9.10	8.40
DESIGN DISCHARGE		
ACCUMULATED DISTANCE	0.00	100.00
DISTANCE	0.00	80.50
STATION	+4.15	+13.30
CURVE		

ELEVATION	SLOPE	
	6.55	6.13
WATER SURFACE		
WATER DEPTH		
CANAL BED	8.59	8.18
GROUND ELEVATION	9.04	8.32
DESIGN DISCHARGE		
ACCUMULATED DISTANCE	0.00	177.05
DISTANCE	0.00	140.00
STATION	+5.45	+13.00
CURVE		

NOTE
 1. ALL DIMENSIONS ARE SHOWN IN METERS UNLESS OTHERWISE INDICATED
 2. ABBREVIATION AND SYMBOL
 E : CENTER LINE
 EL : ELEVATION

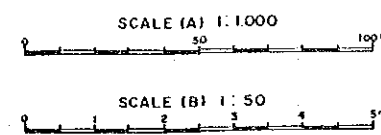

A-LINE IRRIGATION CANAL CROSS SECTION SCALE . B

B-LINE IRRIGATION CANAL CROSS SECTION SCALE . B

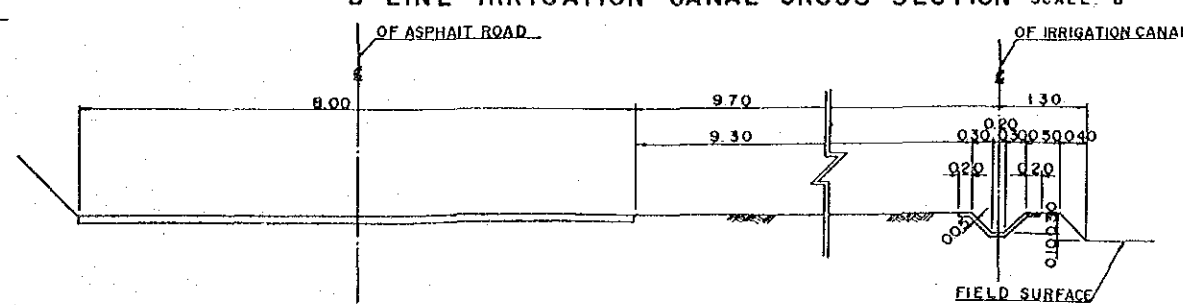
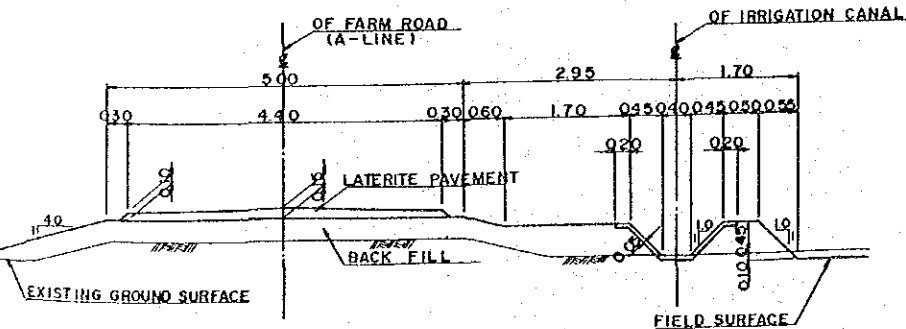

JAPAN INTERNATIONAL COOPERATION AGENCY
 THE DETAIL DESIGN SURVEY FOR THE STRENGTHENING RESEARCH ACTIVITIES PHASE-II PROJECT AT KASETSART UNIVERSITY

VARIETY COLLECTION PLOT
 IRRIGATION CANAL-1 (A-LINE) (B-LINE)

PREPARED BY _____ DRAWING NO. 16
 CHECKED NO. _____

PLANE (C-LINE IRRIGATION CANAL) SCALE. A

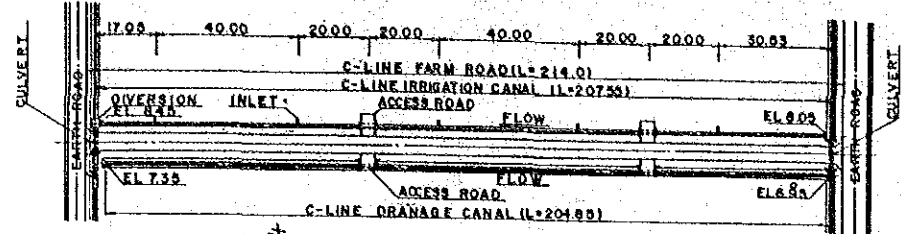

PLANE (D-LINE IRRIGATION CANAL) SCALE. A

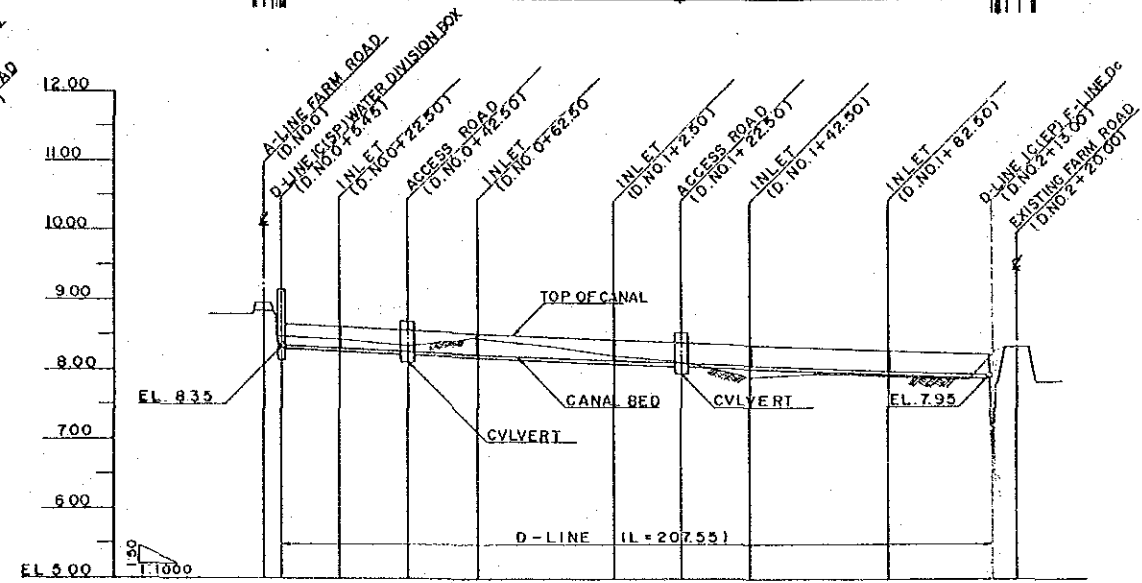
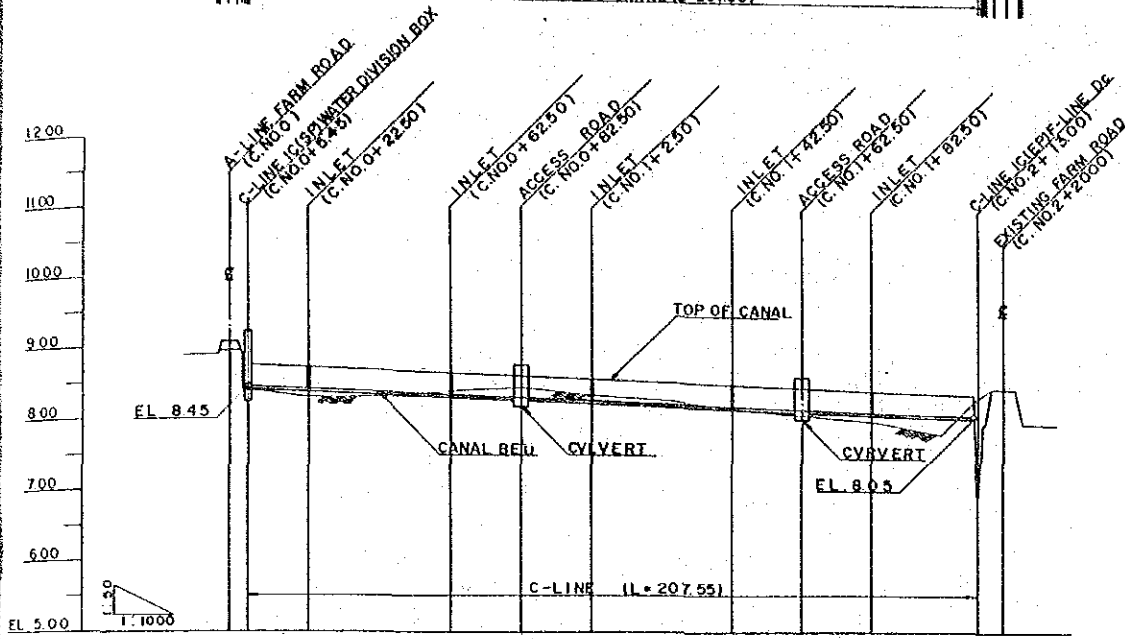
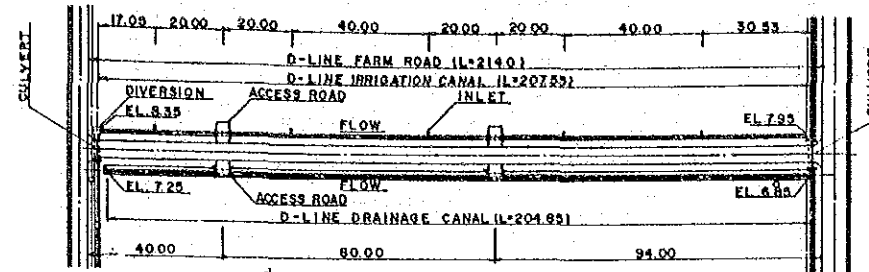

SLOPE
ELEVATION
WATER SURFACE
WATER DEPTH
CANAL BED
GROUND ELEVATION
DESIGN DISCHARGE
ACCUMULATED DISTANCE
DISTANCE
STATION
CURVE

SLOPE		0.33									
ELEVATION		300									
WATER SURFACE											
WATER DEPTH											
CANAL BED		8.45	8.42	8.34	8.30	8.26	8.19	8.15	8.11	8.08	8.05
GROUND ELEVATION		8.90	8.40	8.31	8.39	8.46	8.30	8.25	8.25	8.18	8.15
DESIGN DISCHARGE											
ACCUMULATED DISTANCE		-5.45	0.00	17.05	17.05	17.05	17.05	17.05	17.05	17.05	17.05
DISTANCE		0.00	5.45	17.05	17.05	17.05	17.05	17.05	17.05	17.05	17.05
STATION		C.NO.0 +5.45	+22.50	+40.00	+62.50	+82.50	+102.50	+122.50	+142.50	+162.50	+182.50
CURVE											

SLOPE
ELEVATION
WATER SURFACE
WATER DEPTH
CANAL BED
GROUND ELEVATION
DESIGN DISCHARGE
ACCUMULATED DISTANCE
DISTANCE
STATION
CURVE

SLOPE		0.33									
ELEVATION		300									
WATER SURFACE											
WATER DEPTH											
CANAL BED		8.35	8.32	8.28	8.24	8.17	8.16	8.13	8.09	8.01	7.98
GROUND ELEVATION		8.60	8.47	8.44	8.35	8.47	8.24	8.14	7.90	7.96	7.93
DESIGN DISCHARGE											
ACCUMULATED DISTANCE		-5.45	0.00	17.05	37.05	57.05	94.35	97.05	117.05	137.05	194.35
DISTANCE		0.00	5.45	17.05	20.00	20.00	37.05	2.50	20.00	20.00	17.05
STATION		D.NO.0 +5.45	+22.50	+42.50	+62.50	+82.50	+120.00	+122.50	+142.50	+162.50	+182.50
CURVE											

C, D-LINE IRRIGATION CANAL CROSS SECTION SCALE. B

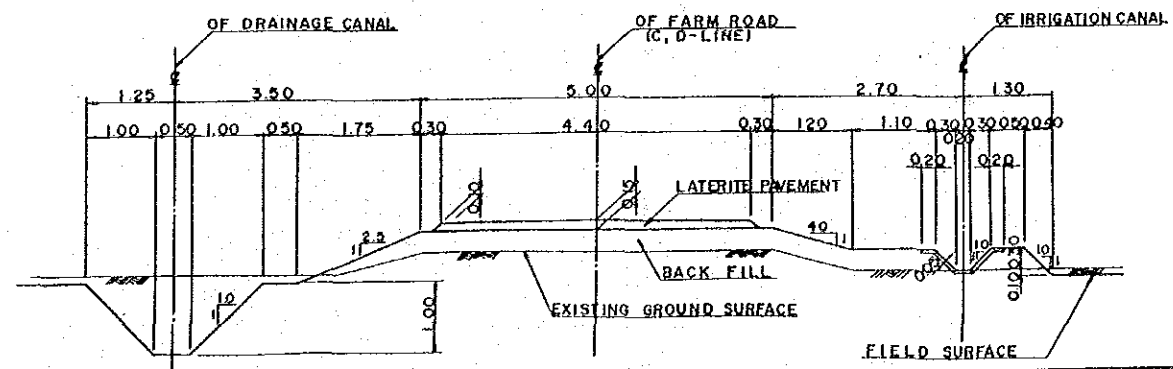

NOTE
1. ALL DIMENSIONS ARE SHOWN IN METERS UNLESS OTHERWISE INDICATED
2. ABBREVIATION AND SYMBOL
Z : CENTER LINE
EL : ELEVATION

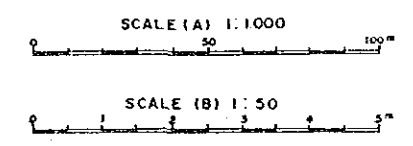

JAPAN INTERNATIONAL COOPERATION AGENCY
THE DETAIL DESIGN SURVEY FOR THE STRENGTHENING RESEARCH ACTIVITIES PHASE II PROJECT AT KASETSART UNIVERSITY

VARIETY COLLECTION PLOT
IRRIGATION CANAL-2 (C-LINE) (D-LINE)

PREPARED BY _____ DRAWING NO. 17
CHECKED NO. _____

PLANE (C-LINE DRAINAGE CANAL) SCALE. A

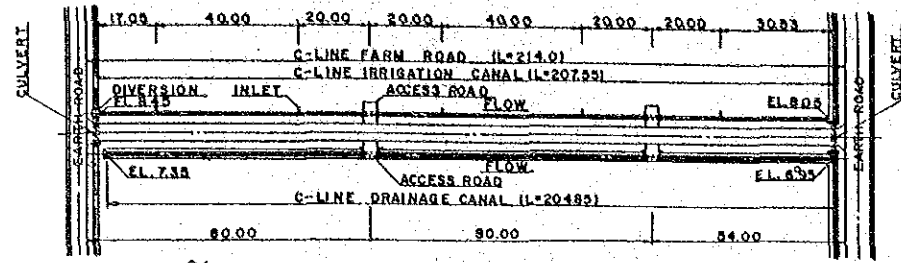

PLANE (D-LINE DRAINAGE CANAL) SCALE. A

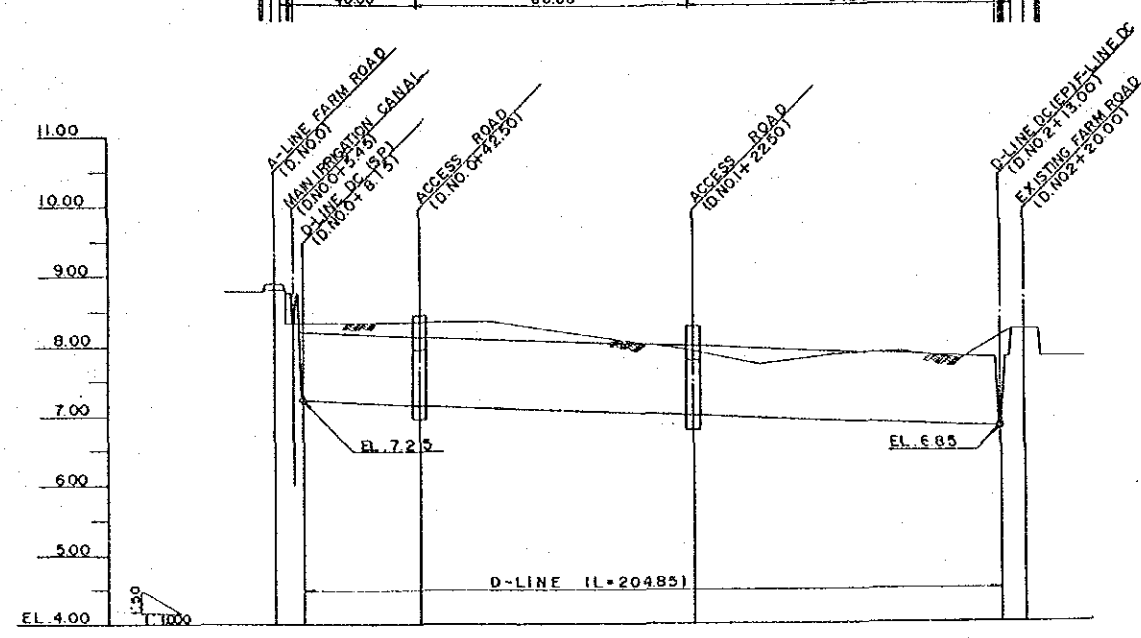
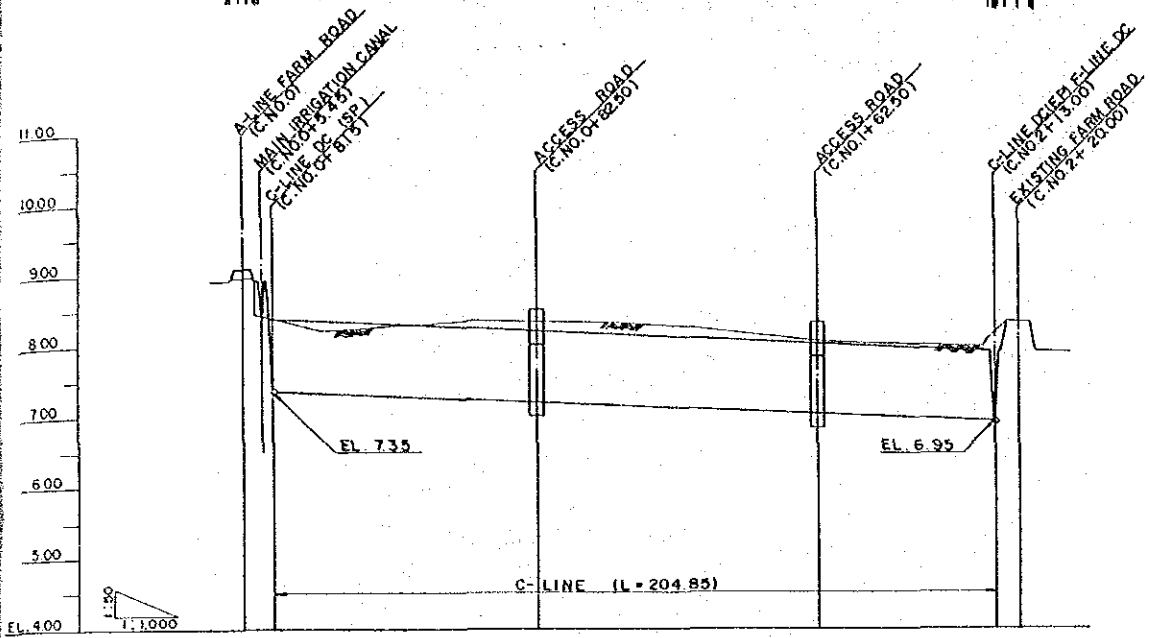
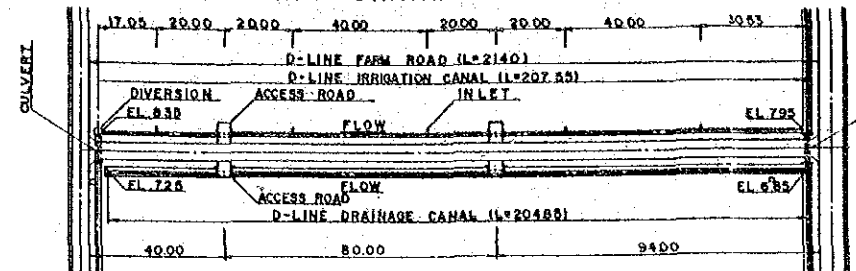

SLOPE	ELEVATION									
	500									
WATER SURFACE										
WATER DEPTH										
CANAL BED	7.35	7.21	7.17	7.05	6.98	6.95	6.85	6.85	6.85	6.85
GROUND ELEVATION	8.90	8.41	8.33	8.34	8.04	7.89	8.30	8.35	8.35	8.35
DESIGN DISCHARGE										
ACCUMULATED DISTANCE	-8.15	0.00	74.35	91.85	154.35	161.85	204.85	204.85	204.85	204.85
DISTANCE	0.00	8.15	74.35	17.50	6.250	37.50	13.00	7.00	7.00	7.00
STATION	C.NO.0	+8.15	+82.50	C.NO.1	+62.50	+62.50	C.NO.2	+13.00	+20.00	+20.00
CURVE										

SLOPE	ELEVATION									
	500									
WATER SURFACE										
WATER DEPTH										
CANAL BED	7.25	7.18	7.07	7.03	6.88	6.85	6.85	6.85	6.85	6.85
GROUND ELEVATION	8.80	8.39	8.38	8.11	7.85	8.20	8.20	8.20	8.20	8.20
DESIGN DISCHARGE										
ACCUMULATED DISTANCE	-8.15	0.00	34.35	91.85	114.35	191.85	204.85	204.85	204.85	204.85
DISTANCE	0.00	8.15	34.35	17.50	22.50	77.50	13.00	7.00	7.00	7.00
STATION	D.NO.0	+8.15	+42.50	D.NO.1	+22.50	+22.50	D.NO.2	+13.00	+20.00	+20.00
CURVE										

C, D-LINE DRAINAGE CANAL CROSS SECTION SCALE. B

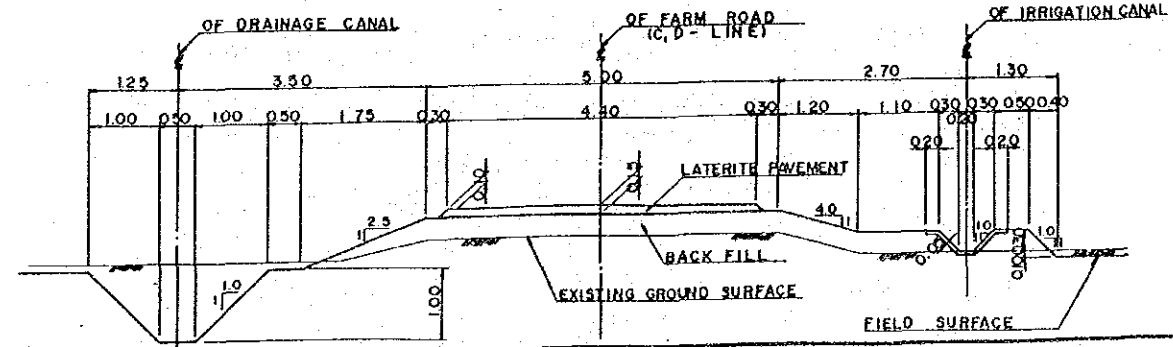

NOTE
 1. ALL DIMENSIONS ARE SHOWN IN METERS UNLESS OTHERWISE INDICATED
 2. ABBREVIATION AND SYMBOL
 E : CENTER LINE
 EL : ELEVATION

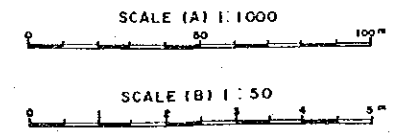

JAPAN INTERNATIONAL COOPERATION AGENCY
 THE DETAIL DESIGN SURVEY FOR THE STRENGTHENING RESEARCH ACTIVITIES PHASE B PROJECT AT VASATSLET UNIVERSITY

VARIETY COLLECTION PLOT
 DRAINAGE CANAL-I (C-LINE) (D-LINE)

PREPARED BY _____ DRAWING NO. 18
 CHECKED NO. _____

PLANE (E-LINE DRAINAGE CANAL) SCALE. A

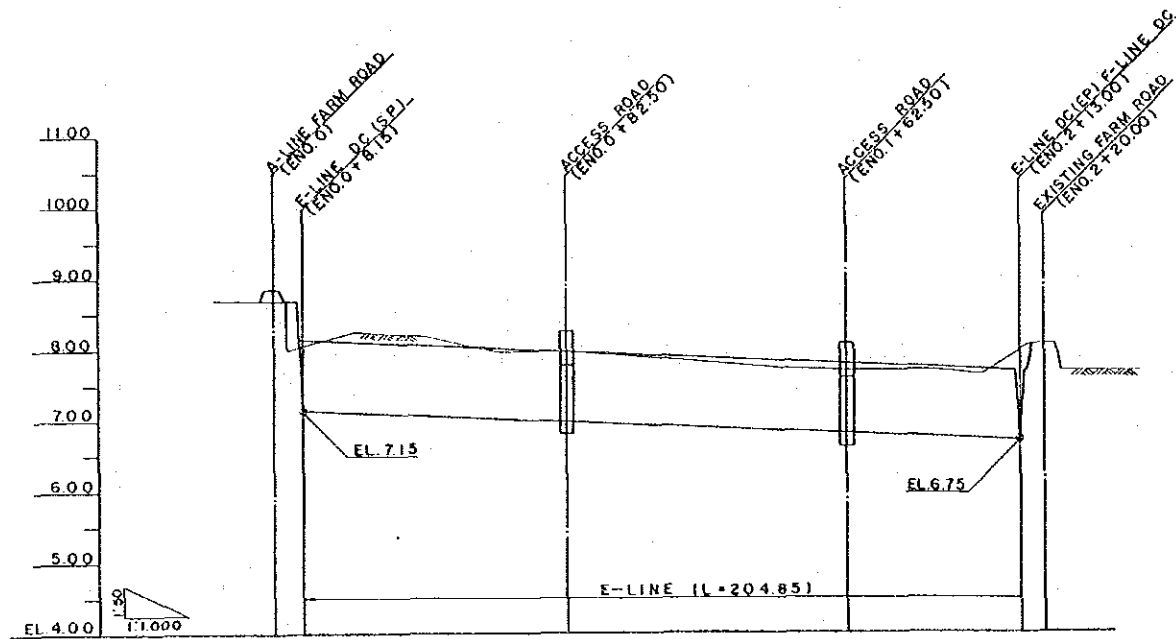
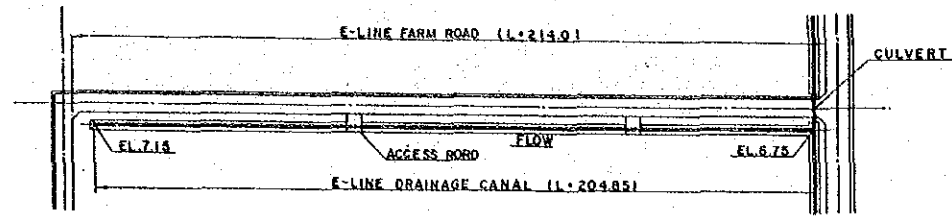

ELEVATION	SLOPE		7.15		6.75	
	WATER SURFACE	WATER DEPTH	7.15	7.01	6.97	6.85
CANAL BED	7.15		7.01	6.97	6.85	6.78
GROUND ELEVATION	8.70	8.01	8.00	7.93	7.77	7.72
DESIGN DISCHARGE						
ACCUMULATED DISTANCE	0.00	8.15	74.35	91.85	154.35	191.85
DISTANCE	0.00	8.15	74.35	17.50	62.50	37.50
STATION	END. 0	+8.15	+82.50	END. 1	+17.50	+62.50
CURVE						

E-LINE DRAINAGE CROSS SECTION SCALE. B

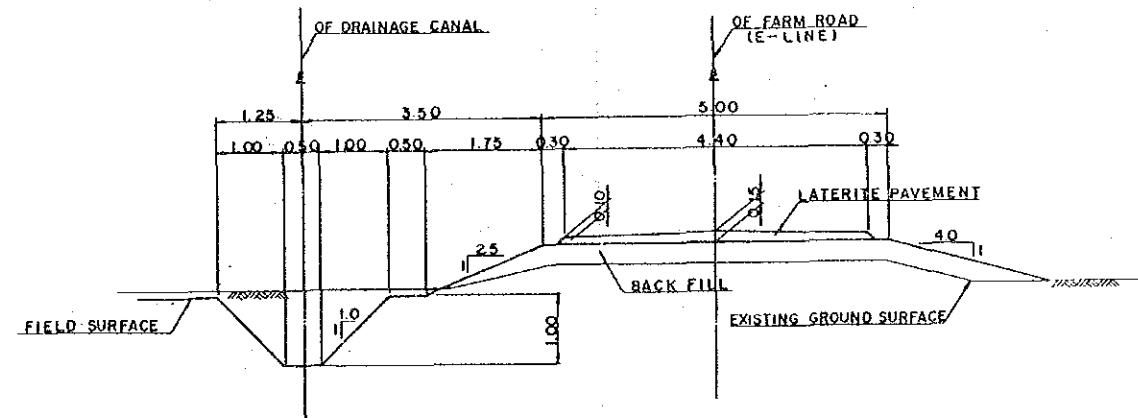

- NOTE
- ALL DIMENSIONS ARE SHOWN IN METERS UNLESS OTHERWISE INDICATED
 - ABBREVIATION AND SYMBOL
 E : CENTER LINE
 EL : ELEVATION

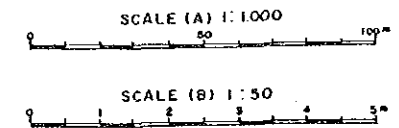

JAPAN INTERNATIONAL COOPERATION AGENCY
 THE DETAIL DESIGN SURVEY FOR THE STRENGTHENING
 RESEARCH ACTIVITIES PHASE 2 PROJECT
 AT KASETSART UNIVERSITY

VARIETY COLLECTION PLOT
 DRAINAGE CANAL-2 (E-LINE)

PREPARED BY _____ DRAWING NO. _____
 CHECKED BY _____ 19

PLANE (C-LINE FARM ROAD) SCALE A

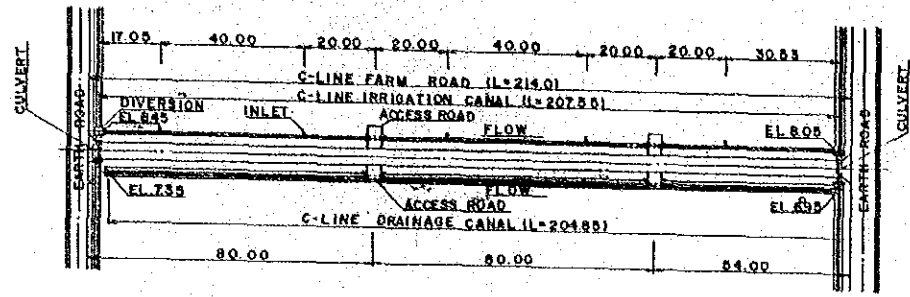

PLANE (D-LINE FARM ROAD) SCALE A

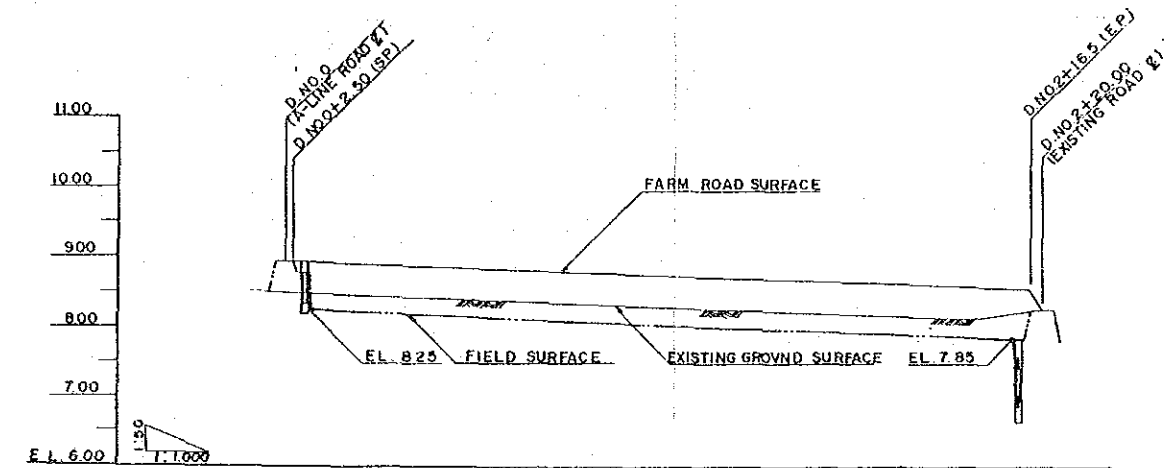
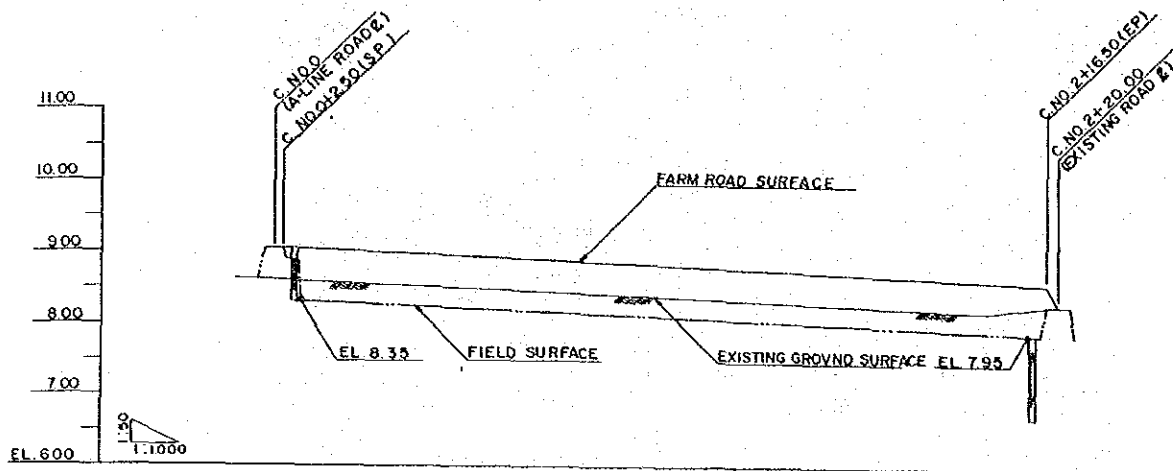
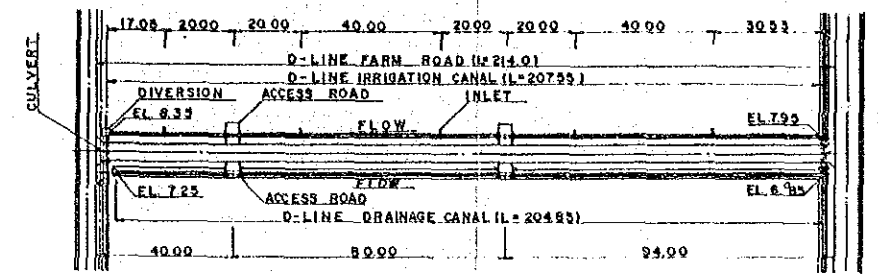

SLOPE	1:500	
EMBANKMENT	8.05	8.66
EXCAVATION	8.65	8.41
GROUND ELEVATION	8.60	8.21
ACCUMULATED DISTANCE	2.50	197.50
DISTANCE	0.00	100.00
STATION	0+00	100+00
CURVE		

SLOPE	1:500	
EMBANKMENT	8.25	8.55
EXCAVATION	8.55	8.11
GROUND ELEVATION	8.50	8.11
ACCUMULATED DISTANCE	0.00	197.50
DISTANCE	0.00	100.00
STATION	0+00	100+00
CURVE		

C, D-LINE FARM ROAD CROSS SECTION SCALE B

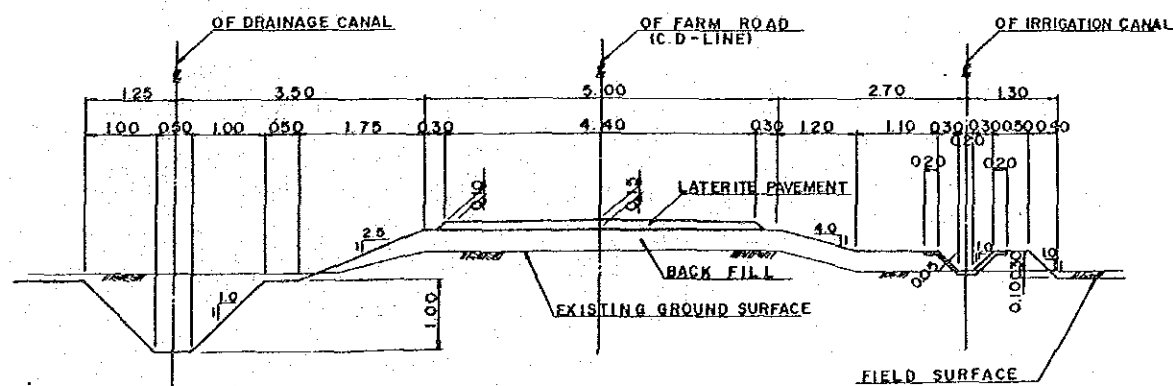

- NOTE
- ALL DIMENSIONS ARE SHOWN IN METERS UNLESS OTHERWISE INDICATED
 - ABBREVIATION AND SYMBOL
 2 : CENTER LINE
 EL : ELEVATION

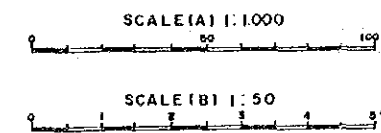

JAPAN INTERNATIONAL COOPERATION AGENCY
 THE DETAIL DESIGN SURVEY FOR THE STRENGTHENING
 RESEARCH ACTIVITIES PHASE, II PROJECT
 AT KASETSART UNIVERSITY

VARIETY COLLECTION PLOT
 FARM ROAD-2 (C-LINE)
 (D-LINE)

PREPARED BY _____ DRAWING NO. 22
 CHECKED NO. _____

PLANE OF ACCESS ROAD SCALE. A

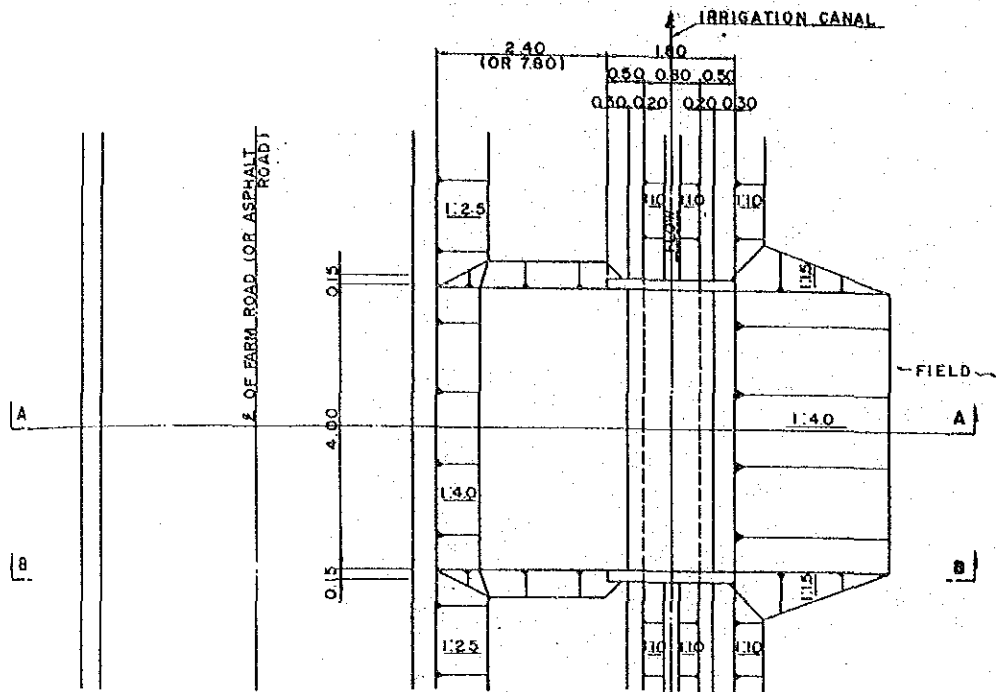

SECTION A - A SCALE. A

PLANE OF ACCESS ROAD SCALE. A

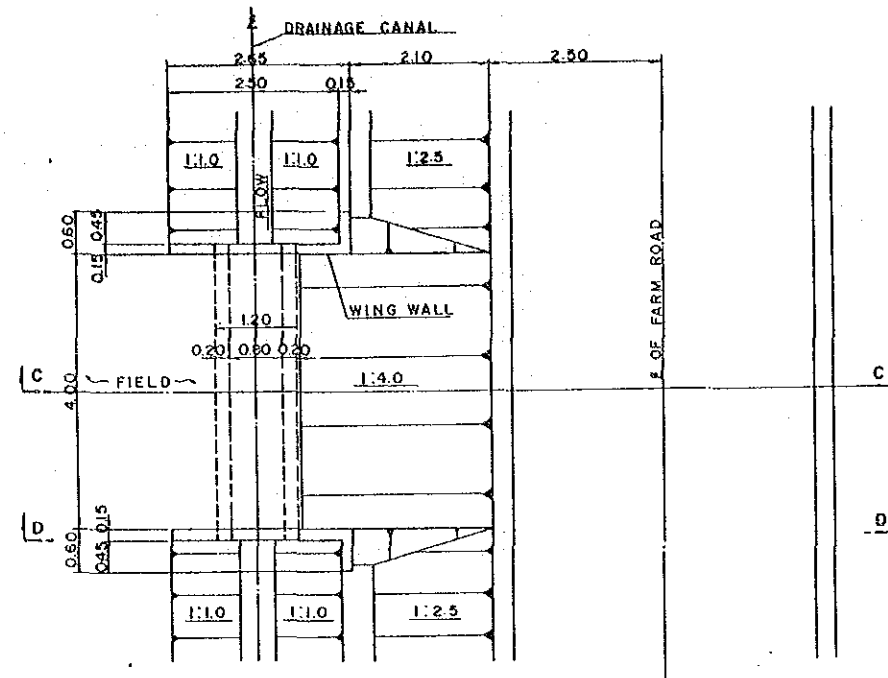

SECTION C - C SCALE. A

ACCESS ROAD CENTER LINE

IRRIGATION CANAL		DRAINAGE CANAL	
D-LINE C-LINE-B-LINE	ENO. 0 + 42.500	E-LINE D-LINE-C-LINE	CNO. 0 + 82.500
	ENO. 1 + 22.500		CNO. 1 + 62.500
	CNO. 0 + 82.500		DNO. 0 + 42.500
	CNO. 1 + 62.500		DNO. 1 + 22.500
	DNO. 0 + 42.500		ENO. 0 + 82.500
	DNO. 1 + 22.500		ENO. 1 + 62.500

PLANE OF INLET SCALE. B

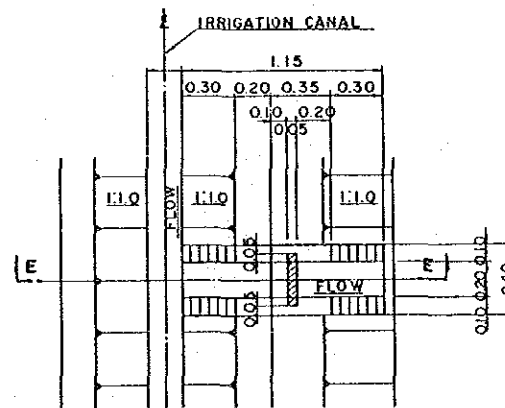

SECTION E - E SCALE. B

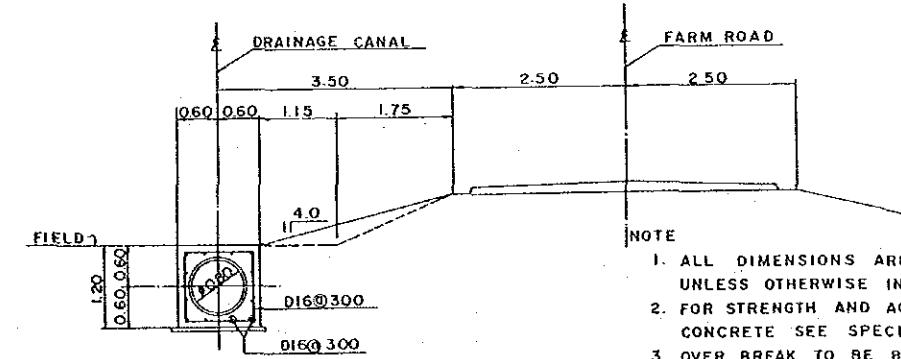

SECTION D - D SCALE. A

- NOTE
1. ALL DIMENSIONS ARE SHOWN IN METERS UNLESS OTHERWISE INDICATED
 2. FOR STRENGTH AND AGGREGATE SIZE OF CONCRETE SEE SPECIFICATIONS
 3. OVER BREAK TO BE BACKFILLED WITH CONCRETE AS DIRECTED BY THE INSPECTOR
 4. WHERE CONCRETE IS POURED DIRECTLY THE SURFACE SHALL BE CLEAN AND FREE OF ALL LOOSE MATERIAL THAT WOULD BE HARMFUL TO BONDING ACTION
 5. ABBREVIATION AND SYMBOL
 SYM : SYMMETRY
 E : CENTER LINE
 EL : ELEVATION

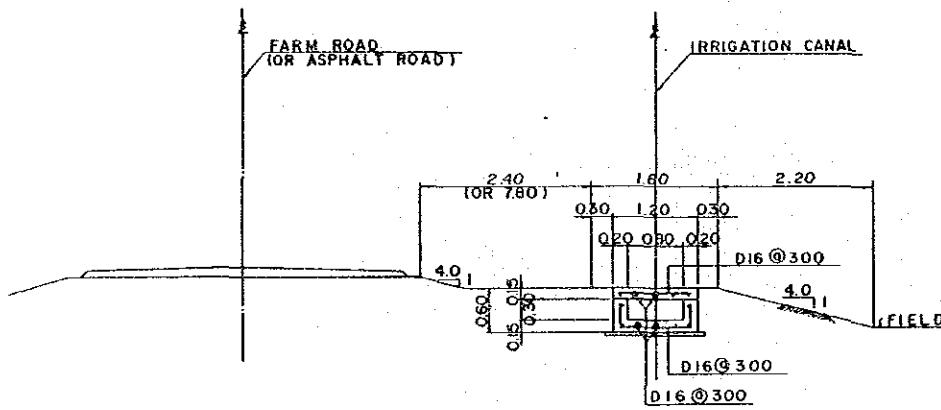
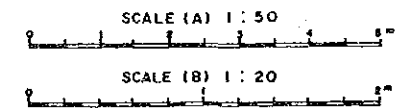

SECTION B - B SCALE. A

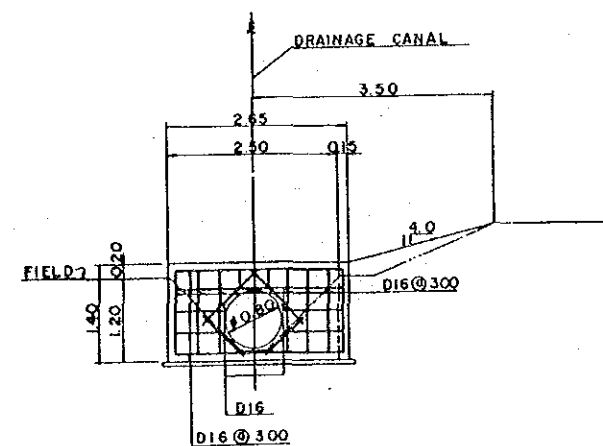
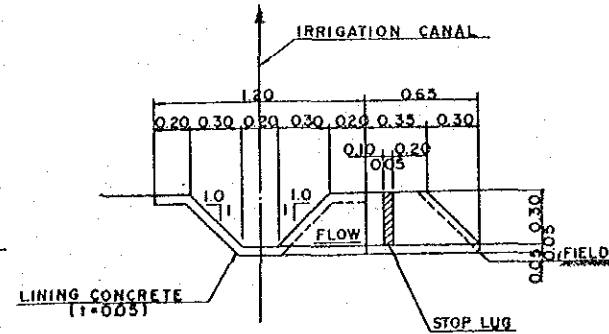
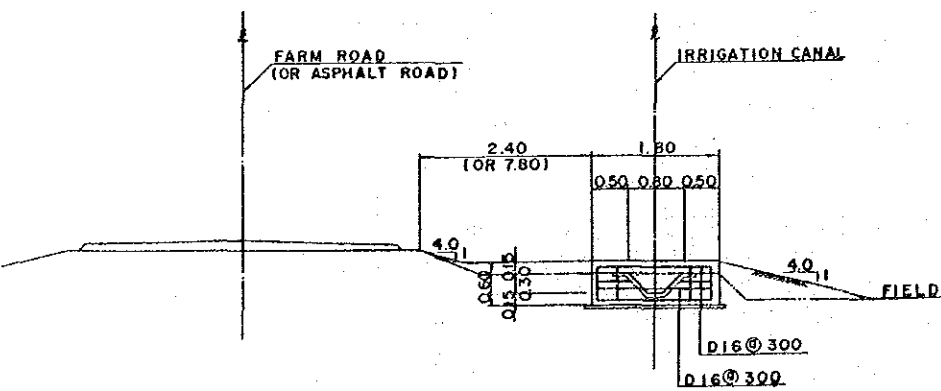

JAPAN INTERNATIONAL COOPERATION AGENCY
 THE DETAIL DESIGN SURVEY FOR THE STRENGTHENING
 RESEARCH ACTIVITIES PHASE II PROJECT
 AT EASATSART UNIVERSITY

VARIETY COLLECTION PLOT
 RELATED STRUCTURE-1

PREPARED BY _____ DRAWING NO. 23
 CHECKED BY _____

PLANE OF CULVERT SCALE. A

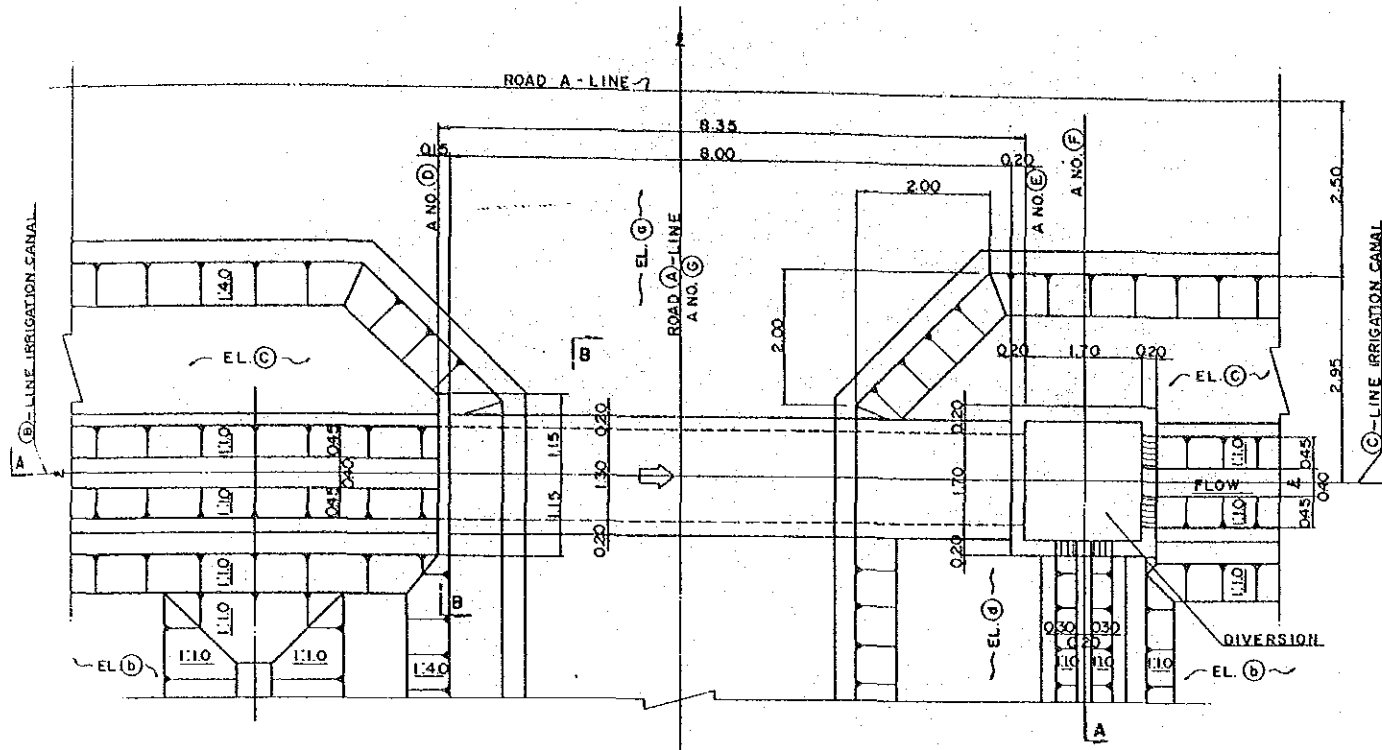

SECTION A - A SCALE. A

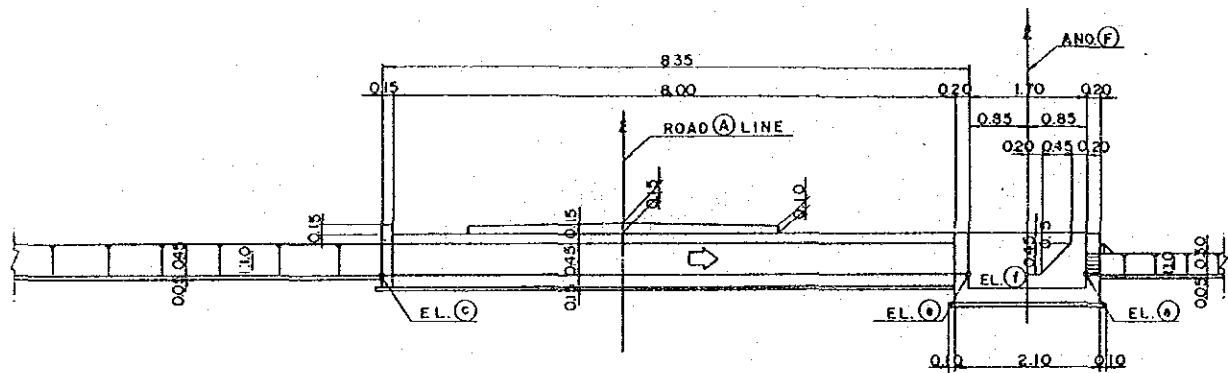

SECTION B - B SCALE. A

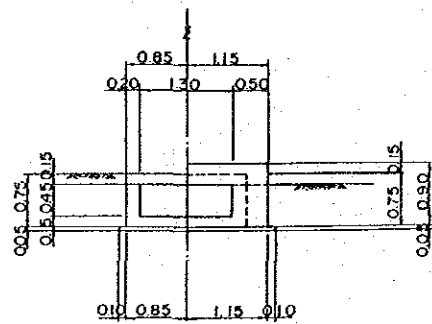

MEASURE RISE					
(A)	(C)	(D)	(E)	(F)	(G)
(A)	C	D	(E)	9.50	9.40
(B)	A-2	A-3	(D)	8.35	8.25
(C)	A-3	—	(C)	8.90	8.80
(D)	1+10.30	2+10.30	(D)	8.75	8.65
(E)	1+18.65	2+18.65	(E)	8.45	8.35
(F)	1+19.5	2+19.5	(F)	8.25	8.15
(G)	1+14.3	2+14.3	(G)		

PLANE OF CULVERT SCALE. A

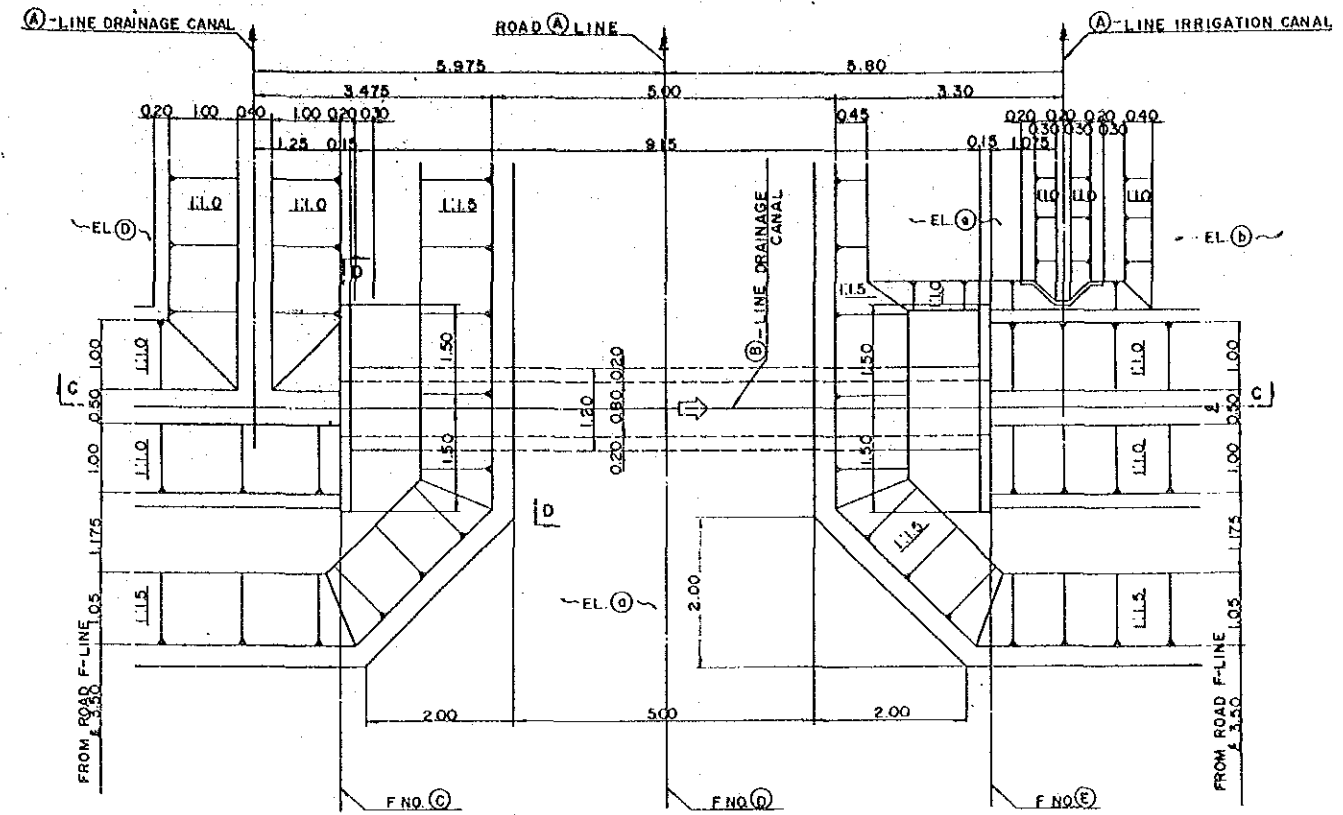

SECTION C - C SCALE. A

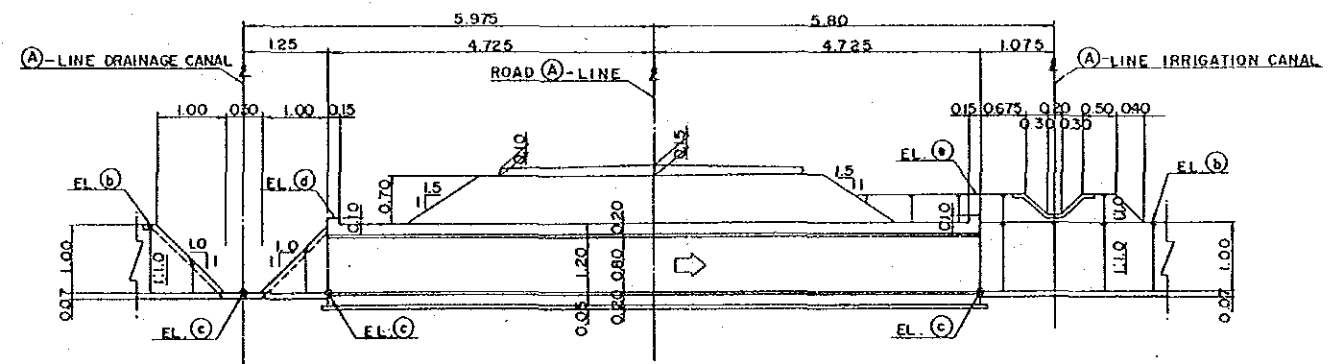

SECTION D - D SCALE. A

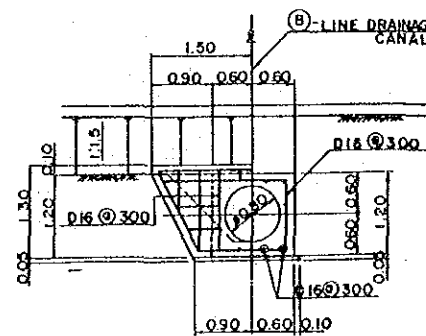

NOTE

1. ALL DIMENSIONS ARE SHOWN IN METERS UNLESS OTHERWISE INDICATED.
2. FOR STRENGTH AND AGGREGATE SIZE OF CONCRETE SEE SPECIFICATIONS.
3. OVER BREAK TO BE BACKFILLED WITH CONCRETE AS DIRECTED BY THE INSPECTOR.
4. WHERE CONCRETE IS POURED DIRECTLY THE SURFACE SHALL BE CLEAN AND FREE OF ALL LOOSE MATERIAL THAT WOULD BE HARMFUL TO BONDING ACTION.
5. ABBREVIATION AND SYMBOL
 SYM : SYMMETRY
 & : CENTER LINE
 EL : ELEVATION

MEASURE RISE							
(A)	(C)	(D)	(E)	(F)	(G)	(H)	(I)
(A)	C	D	(E)	(F)	(G)	(H)	(I)
(B)	F-2	F-3	F-4	(B)	7.95	7.85	7.75
(C)	1+10.275	2+10.275	3+10.275	(C)	8.95	6.85	6.75
(D)	1+15.000	2+15.000	3+15.000	(D)	8.05	7.95	7.85
(E)	1+19.725	2+19.725	3+19.725	(E)	8.35	8.25	8.15

SCALE (A) 1 : 50

JAPAN INTERNATIONAL COOPERATION AGENCY
 THE DETAIL DESIGN SURVEY FOR THE STRENGTHENING
 RESEARCH ACTIVITIES PHASE B PROJECT
 AT KASETSART UNIVERSITY

VARIETY COLLECTION PLOT
 RELATED STRUCTURE - 2

PREPARED BY
 CHECKED NO.
 DRAWING NO.
 24

PLAN OF CULVERT SCALE. A

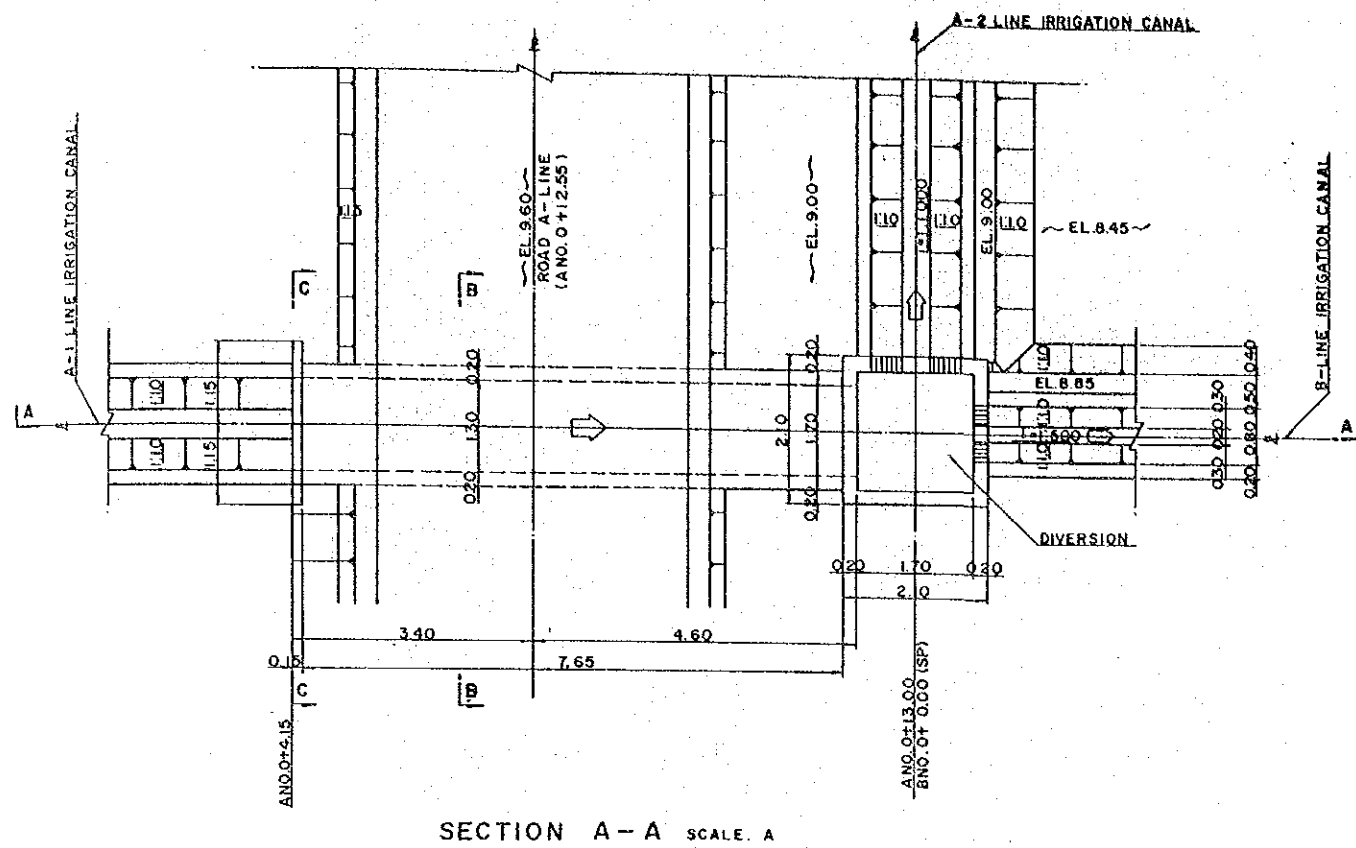

PLAN OF DIVERSION SCALE. A SECTION D-D SCALE. A SECTION E-E SCALE. A

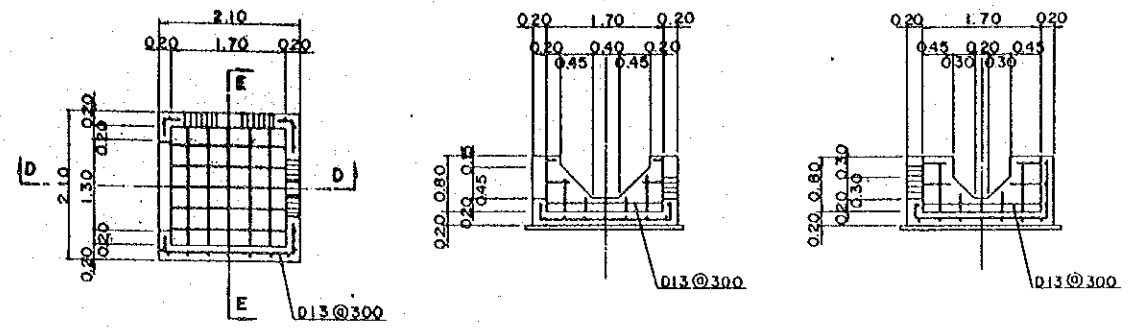

SECTION A-A SCALE. A

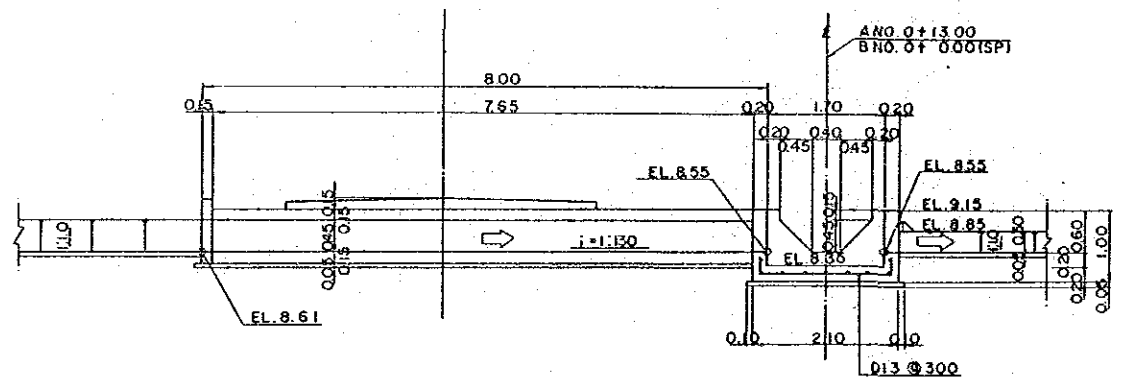

SECTION B-B SCALE. A

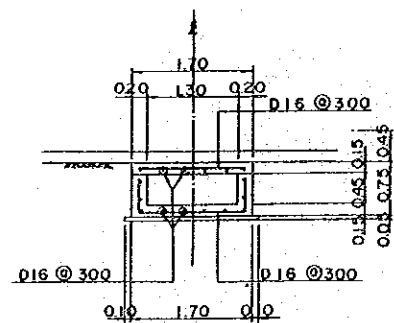

SECTION C-C SCALE. A

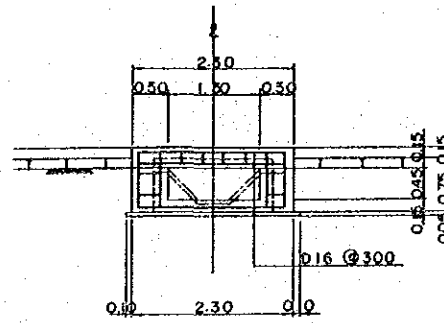

NOTE

1. ALL DIMENSIONS ARE SHOWN IN METERS UNLESS OTHERWISE INDICATED
2. FOR STRENGTH AND AGGREGATE SIZE OF CONCRETE SEE SPECIFICATIONS
3. OVER BREAK TO BE BACKFILLED WITH CONCRETE AS DIRECTED BY THE INSPECTOR
4. WHERE CONCRETE IS POURED DIRECTLY THE SURFACE SHALL BE CLEAN AND FREE OF ALL LOOSE MATERIAL THAT WOULD BE HARMFUL TO BONDING ACTION
5. ABBREVIATION AND SYMBOL
 SYM : SYMMETRY
 E : CENTER LINE
 EL : ELEVATION



JAPAN INTERNATIONAL COOPERATION AGENCY
 THE DETAIL DESIGN SURVEY FOR THE STRENGTHENING
 RESEARCH ACTIVITIES PHASE II PROJECT
 AT KASETSART UNIVERSITY

VARIETY COLLECTION PLOT
 RELATED STRUCTURE-3

PREPARED BY _____ DRAWING NO. 25
 CHECKED NO. _____

CHAPTER 7 BID DOCUMENTS

BID DOCUMENTS

FOR

CONSTRUCTION OF MODEL INFRASTRUCTURE IMPROVEMENT WORK

ON

STRENGTHENING RESEARCH ACTIVITIES

PHASE II PROJECT

AT

KASETSART UNIVERSITY

KAMPHAENGAEN CAMPUS

BANGKOK OFFICE

JAPAN INTERNATIONAL COOPERATION AGENCY

C O N T E N T S

- * Invitation for Bids
- * Instruction to Bidders
- * Terms and Condition of this Contract
- * Pledge Agreement
- * Contract
- * Technical Specifications
- * Proposal

JAPAN INTERNATIONAL COOPERATION AGENCY

BANGKOK OFFICE

INVITATION TO BID NO. _____

The Japan International Cooperation Agency, Bangkok Office hereby invites sealed written bids for the Construction of Model Infrastructure on the Strengthening Reserch Activities Phase II Project in Kasetsart University Kamphaengsaen Campus (hereinafter referred to as "the Project") which is situated in. The project has a total area of about 11.0 ha.

This Contract will include, among others, the following;

1. Terms and Conditions of this Contract
2. Pledge Agreement
3. Technical Specification
4. Bill of Quantities
5. Drawings

Bids shall be addressed to _____ Resident Representative, Japan International Cooperation Agency, Bangkok Office, 1674 / 1, New Petchburi Road, Bangkok 10310, Thailand, and marked "Sealed Proposal, K.U.Phase II P. Model Infrastructure".

The date for the opening of bids will be held at _____ o'clock p.m. (a.m.), _____ Standard Time on _____ (month) _____ (day) _____, 1989 at the JICA, Bangkok Office.

(Name)

Resident Representative of JICA
Bangkok Office

INSTRUCTION TO BIDDERS

IB-01 PREPARATION OF BIDS

All bids shall be submitted in an original and three (3) copies on or before the hour and date fixed for receipt of bids, in accordance with the Invitation for Bids, and shall conform to the following requirements;

- a) One copy of proposal shall be marked "original". The original and copies of bids shall be submitted in its entirety with all blanks in the proposal properly filled in.
- b) Bids prices shall be written in words as well as in figures. In case of discrepancy between the words and figures, the price in words shall prevail.
- c) The proposal must be signed by the Bidder with his usual signature and shall show his full business address.

IB-02 BASIS ON WHICH BIDS ARE REQUESTED

The form of the Contract to be awarded is on fixed unit Price basis of payment to the Contractor, as specifically set forth in these Contract Documents. Bids are requested on the above basis and a proposal which is on any other basis will not be considered.

Quotation of prices shall be made in Thai Baht and the Contractor shall be paid in Local Currency.

IB-03 BID SECURITY

The original, but not the copies of each bid, shall be accompanied by a proposal bond in an amount equivalent to (10) % of the total bid price in the form of cash or certified check, as a guarantee that the successful bidder will, within ten (10) days from receipt of the notice of award, enter into Contract with the Japan International Cooperation Agency, Bangkok Office, and complete faithful performance of the work specified in these Contract Documents. In case the successful bidder fails for any reason to execute such contract within the stipulated time, the bid security shall be

forfeited to the Japan International Cooperation Agency, Bangkok Office, as liquidated damages.

The bid securities will be returned without interest after the successful bidder has signed the Contract.

IB-04 DELIVERY OF BIDS

Bids shall be directly delivered to JICA Bangkok Office,
_____ on or before the hour and date set
for the opening of bids.

IB-05 WITHDRAWAL OF BIDS

A bidder will be allowed to withdraw his bid prior to the time set for the opening of bids if he communicate his purpose in writing to the Japan International Cooperation Agency, Bangkok Office, and his bid shall be returned to him unopened. No bid can be withdrawn for any reason whatsoever after the opening of bids has been made.

IB-06 BIDDER'S RESPONSIBILITY

The bidders shall be responsible for having taken steps to carefully examine all of the Contract Documents and also to have fully informed themselves as to all conditions, local and otherwise, affecting the carrying out of the Contract Works. Failure to do so will be at the Bidder's risk.

IB-07 DATA TO BE SUBMITTED WITH PROPOSAL

All proposal shall contain the following documents:

- a) A construction schedule showing the detailed proposal plan of operation and construction of each main item in the Bill of Quantities from start to completion of the Contract work. The schedule shall be in a bar chart form with weeks shown as the least unit of time and each main item on a separate horizontal line. The schedule shall also show expected monthly accomplishment and financial requirements based on the Bill of Quantities.
- b) A list of equipment proposed to be used for the performance of the Contract Work. This list shall specifically enumerate the number, type and capacity.

IB-08 INTERPRETATION OF CONTRACT DOCUMENTS

If the prospective Bidder is in doubt as to the true meaning of any part of the Contract Documents, the Bidder may submit to the Japan International Cooperation Agency, Bangkok Office, a written request for interpretation allowing sufficient time for a reply to reach him before submission of his bid. Any interpretation of the proposed documents will be made only be a Supplemental Notice duly issued.

IB-09 PRE-BIDDING CONFERENCE

A pre-bidding conference will be scheduled on (month) (day) , 1989 at (hour) o'clock p.m./a.m.) at (place) . Attendance for Contractors is desirable but not mandatory.

IB-10 COMPARISON OF BIDS

In making its selection, the Japan International Cooperation Agency, Bangkok Office will not be bound to award a Contract to the bidder submitting the Bid with the lowest indicated cost, but will take into consideration the bid prices, unbalanced bids, guaranteed completion time and other relevant consideration.

IB-11 AWARD OF CONTRACT

Bids will be opened in the presence of the Bidders who may desire to attend such opening by the Japan International Cooperation Agency, Bangkok Office, at (hour) o'clock p.m./a.m.) () Standard Time On (month) (day) , 1989.

Promptly after the opening of the bids the Japan International Cooperation Agency, Bangkok Office will undertake a detailed study and appraisal of the proposal submitted. The Contract will be awarded to the Bidder whose proposal is considered to be the most advantageous to the Japan International Cooperation Agency, Bangkok office. The Japan International Cooperation Agency, Bangkok Office reserves the right to reject any and all bids received.

IB-12 BID DOCUMENTS

Bid documents shall include the following:

- a) Invitation for Bids
- b) Instruction to Bidders
- c) Terms and conditions of this Contract
- d) Pledge Agreement
- e) Contract
- f) Technical Specification
- g) Proposal
- h) Bill of Quantities
- i) Drawings

TERMS AND CONDITIONS OF THIS CONTRACT

Section 1 General Information

1.1 Objective

According to the Record of Discussion signed Apr. 16, 1987, technical cooperation concerning The Strengthening Research Activities Phase II Project in Kasetsart University, Kamphaengsaen Campus (hereinafter referred to as "the Project") will be carried out.

The objective of the Works are to construct the testing field which is necessary for the Project.

1.2 Location of the site

The job site is located at Kasetsart University, Kamphaengsaen Campus (K.U.K.C.), Nakon Pathom, 73140.

1.3 Collaboration

Accordingly the objective of the technical cooperation, the counterpart agency of the JICA is executing several experiments around the job site. Prior to or during the course of the Works, the Contractor shall make the good relation with the K.U.K.C. for the satisfactory implementation of the Works as to secure full collaboration. Should it happen that the relation between the K.U.K.C. and the Contractor is disturbed, the Contractor shall inform the Inspection Committee who will conciliate the both parties.

Section 2 Submission of Notices

2.1 Work schedule

The Contractor shall submit the Work Schedule in following items before the commencement of the Works at the job site. If the Contractor intends to change the Works at the job site. If the Contractor intends to change the Work schedule, the approval from the Inspection Committee shall be obtained prior to the modification of the schedule.

1. Preparation of facilities and transportation of equipment etc. to the job site
2. Land shape adjustment and land levelling
3. Irrigation canal
4. Drainage canal
5. Farm road
6. Concrete level
7. Net house
8. Clearing away

Also the Contractor shall submit the machineries scheme including the numbers, and kind of machineries and using period of them.

2.2 Notices

The JICA and the Contractor shall submit the notices to each other, as necessary, in accordance with Article in this Contract within reasonable time except that special articles are provided Terms and Conditions of this Contract.

Section 3 Field Test and Inspection

The field tests in accordance with the Technical Specification and the demands from the Inspection Committee shall be the responsibility for the Contractor. The charges for such field test shall be included in the total amount of the construction cost, and the Contractor is not entitled to claim any amount of the field test charges.

Section 4 Modification of Plan

In case the JICA estimate the cost for the modification in accordance with Article, and if there are two portions, one for the increase and the other for the decrease of the construction cost resulting from such modification, the JICA shall have the right to offset them in the payment and pay or claim the difference between the increase and decrease of the construction cost as the case may be.

Section 5 Release from the Works

After the final acceptance of the Works by the JICA, the Contractor shall remove its own temporary facilities, warehouses, construction roads, electric wiring, surplus material, debris and so forth which were provided by the Contractor within 10 (ten) days. Upon approval of the Inspection Committee for the removal of the abovementioned facilities etc., the Contractor will be released from its responsibility of the Works but remains responsible under 1 (one) year guarantee of the Works as specified in Article in this Contract.

Section 6 General Obligations of the Contractor

6.1 Temporary office and residence

In case the Contractor intends to build the temporary office, residence and so forth, the Contractor shall submit the plan to the Inspection Committee for approval at least 10 (ten) days in advance of the commencement of the Works.

The Contractor is required to always keep the buildings and facilities in good condition and to make proper drainage and sanitary system. Should the Contractor build them outside of the job site, the Contractor shall arrange with the owner of the such land and at its own expense.

6.2 Fuel storage

In area of temporary office and residence, the fuel tank capacity shall not exceed 1,000 liters and shall be far away from the housing area.

Fuel storage and transportation shall be done with care and shall have a good system of fire prevention. If storage licence is required, the Contractor shall arrange for obtaining it.

6.3 Other facilities

All necessary facilities for the Works and the Contractor's convenience shall be provided and maintained in good condition by the Contractor.

Section 7 General Text

The Contractor shall implement the Works in accordance with the Contract Documents in broad sense such as the Contractor in narrow sense, Terms and

Conditions of this Contract, Technical Specification. Should the events occur that the both parties can not reach agreement on the interpretation of the above-mentioned Contract Documents in broad sense, both parties shall negotiate with sincerity and good faith for settlement of any disagreement, failing which the decision of the JICA shall prevail.

PLEDGE AGREEMENT

TO JAPAN INTERNATIONAL COOPERATION AGENCY, Date _____
Bangkok Office

We _____, the Contractor hereby agree that all equipment, materials and supplies brought to the job site under this Contract made with the JICA dated on _____, shall be pledged by us with the JICA as security for our execution of Works, and shall not be removed at any time without prior approval of the JICA in writing.

We further agree that should there be any loss or damage to pledged equipment, materials and supplies kept at the job site, the JICA shall bear no responsibility whatsoever for such loss or damage.

CONTRACT

FOR

CONSTRUCTION OF MODEL INFRASTRUCTURE IMPROVEMENT WORK

ON

STRENGTHENING RESEARCH ACTIVITIES

PHASE II PROJECT

AT

KASETSART UNIVERSITY

KAMPHAENSAEN CAMPUS

BANGKOK OFFICE

JAPAN INTERNATIONAL COOPERATION AGENCY

CONTRACT

CONSTRUCTION OF MODEL INFRASTRUCTURE
ON THE STRENGTHENING RESEARCH ACTIVITIES
PHASE II PROJECT

IN

KASETSART UNIVERSITY KAMPHAENGAEN CAMPUS

This Contract is executed on the _____ day of _____
at the JICA Bangkok Office between _____

_____ Japan International Cooperation Agency, Bangkok Office by _____
_____ Title _____ as its
authorized representative of the JICA Bangkok Office, hereinafter referred to as "the
JICA" of the one part, and _____
whose office is situated at _____
_____ Tel. _____ Represented by _____
Nationality _____ Title _____
_____ hereinafter referred to as "the Contractor", of the other part.

Both parties mutually agree under the terms of this Contract as follows:-

Article 1 Purpose of agreement and Contract Price

The JICA agrees to employ the Contractor and the Contractor agrees to perform
the Works for the construction of Model Infrastructure on the Strengthening Research
Activities Phase II Project in Kasetsart University Kamphaengsaen Campus For the
total amount of _____ Baht (_____ Baht), hereinafter
referred to as "Contract Price".

The following documents shall form integral part of this Contract:-

Terms and conditions of this contract

Pledge agreement

Technical specification

Bill of Quantities

Drawings

Article 2 Performance Bond

As a security for the faithful performance of the Works under this Contract, the Contractor has on the execution of this Contract deposited a performance bond with the JICA in lieu thereof a Bank Guarantee issued by the The Bank of bearing the number _____ and dated _____ in the amount of _____ Baht (_____ Baht) which represents five (5) percent of the Contract Price, the name of the issuing bank and the form of the bank guarantee are to be approved by the JICA.

The JICA will return the Performance Bond in cash or the Bank Guarantee to the Contractor as the case may be at the end of the twelve (12) months after final acceptance of the Works by the JICA as stipulated in Article 15 of this Contract, provided that the completed Works shall not show any defect or damage caused through the fault of the Contractor, or through the fault of any new Contractor in the case of termination of Contract by the JICA under article 4.

Should the Contractor be in default, the JICA shall have the right to demand payment from all or any part of the Performance Bond. In addition, the Contractor shall remain liable for the full loss sustained by the JICA.

Article 3 Payment

The JICA agrees to effect payments for the Works to the Contractor in the following manner:-

- a. Advance Payment, to be effected upon the bringing of equipment and materials required for the Works and properly stored at the job site by the Contractor and of value estimated by the Inspection Committee.

Baht (baht) which corresponds to Thirty (30) percent of the Contract Price shall be paid upon signing of this Contract.

- b. Interim Payment, to be effected according to the progress of the Works satisfactorily executed by the Contractor and accepted by the Inspection Committee.

Baht (baht) which corresponds to Forty (40) percent of the Contract Price shall be requested for payment at

- c. Final Payment, to be effected upon the satisfactory completion of the Works by the Contractor and accepted by the Inspection committee.

The remainder of Baht (Baht) which corresponds to Thirty (30) percent of the Contract Price, shall be paid after the Final Certificate by the JICA for payment to the Contractor.

Payment under (b) and (c) shall be effected within the (10) days after the respective acceptance of the Works by the Inspection Committee.

Taxes payable by the Contractor, if any, shall be deducted at source by the JICA on each payment.

It is expressly understood that payments by the JICA do not mean acceptance responsibilities under this Contract.

Article 4 Completion Time

The Contractor agrees to commence the Works at the site within ten (10) days from the date of signing of this Contract (commencement date) and the Contractor agrees to satisfactorily complete the Works within _____ days (completion

time) from the date hereof which will become due on _____
(completion date).

If the Contractor fails to commence the Works by the above commencement date, or should in the course of the construction any event occur which may reasonably cause the JICA to believe that the Contractor will not be able to complete the Works on the completion date, or should the Contractor fail to complete the Works by the completion date, or should the Contractor fail to meet any of the Contract requirement, the JICA shall have the right to terminate this Contract by giving written notice to the Contractor.

However, in case that the Contractor fails to complete the Works by the completion date, or to meet any of the Contract requirement, if the Inspection Committee thinks that the Contractor has the ability for completion of the Works within reasonably extended period, the Contractor may be permitted by the JICA to continue the Works beyond the completion date but within the extended time.

Article 5 Penalty

In case that the Contractor is in default as mentioned in Article 4, the Contractor agrees to be responsible to the JICA as follows:-

5.1 In case of the termination by the default of commencement for the Works, the Contractor shall pay a penalty of _____ Baht (_____ Baht) per day counting from the commencement date until the new Contract is completely executed with a new Contractor for this Works, the period of which is included the time spent for finding the new Contractor and executing the new Contract etc.

5.2 In case the JICA thinks that the Contractor will not be able to complete the Works within the completion time and thereby terminates this Contract, the Contractor shall pay a penalty of _____ Baht (_____ Baht) per day counting the number of days in the same manner as prescribed in 5.1 above. However, the JICA may reduce such number of days according to the ratio between the completed Works and the total Works as may be decided by the Inspection committee.

5.3 In case the Contractor fails to complete the Works by the completion date or to meet any Contract requirement, the Contractor shall pay a penalty of _____ Baht

(Baht) per day counting from the date following the completion date until the Works satisfactorily completed and accepted by the Inspection Committee.

Article 6 Compensation

If the JICA sustains any losses as direct or indirect damages caused by the Contractor's failure, the Contractor shall compensate the JICA for such losses. The parties agree that time is essential for the completion of the Works.

Article 7 The JICA's right for default

The JICA has the sole and absolute right to decide whether to terminate the Contract, to impose only the penalty on the Contractor to claim the compensation for the damage as stated in Article 5 or Article 6. The money due to the JICA exercising its right under this article shall be retained and deducted from any money due to the Contractor but yet unpaid, including from the performance bond. If the total amount of the loss is larger than the money above-mentioned, the Contractor agrees that the JICA has the right to retain the construction equipment, materials and supplies etc. and demand payment of the balance from such equipment etc. or proceeds of sale thereof.

Article 8 Contractor's responsibility on termination of this Contract

After the contract has been terminated in accordance with the foregoing Article 4, the JICA shall have the right to employ another Contractor (hereinafter referred to as "New Contractor") to carry on the remaining parts of the Works, and the payment for the Contractor that fail to complete the work shall be made out of the necessary Contract price for the remaining Works. Should the remaining amount after payment of the advance and interim payment from the Contract price, be insufficient to effect payment to the new Contractor, the difference between such remaining amount and actual cost estimated by the JICA for the satisfactory completion Works carried out by the new Contractor, shall be deemed as direct loss sustained by the JICA, and the Contractor shall pay such difference to the JICA within ten (10) days from the date of request by the JICA, failing which interest at the rate of eighteen (18) percent per annum shall be charged thereon.

Article 9 Inspection Committee

The Inspection committee, authorized to act on behalf of the JICA will be appointed by the JICA and the Inspection Committee is entitled to do all things that the JICA may do so. The Inspection Committee shall control and supervise the Works all the times whether it is in the preparation or implementation of the Works and the Contractor shall promptly furnish all necessary facilities for proper inspections of the Works in accordance with the Inspection Committee's request. At any moment the Inspection Committee can request the Contractor to stop the Works, if necessary and the Contractor shall have no claim on the JICA for extension of the completion time due to such suspension of the Works under this Article.

The inspection will not be deemed as the acceptance of the Works, and the Contractor shall not be relieved from his responsibility to meet the Contract requirements by the fact that the Inspection Committee exercise their duties. Should it be found that the Works have not been satisfactorily performed in the faithful manner, the Contractor shall correct any part of the Works indicated by the Inspection Committee within the period specified by the Inspection Committee.

Article 10 Prohibition for the equipment removal

Should the Contractor fail to complete the Works during the completion time or the Inspection Committee thinks that the Contractor will not be able to satisfactorily complete the Works, any equipment and materials brought to the site for use on the Works shall not be removed without the prior approval of the Inspection Committee in writing.

Article 11 Rectification of the defective construction

For a further period of One (1) year after satisfactory completion and final acceptance of the Works by the JICA, whether completed by the Contractor or by the new Contractor in case of termination of Contract under article 4, any damage to the Works which is caused by the Contractor's fault, either because of defective workmanship or the use of inferior materials or any other cause, shall be made good as necessary by the Contractor to the satisfaction of the JICA at no extra cost.

In case of the termination of the Contract, the JICA may decide which part of the Works should come under the Contractor's responsibility, and requests the Contractor to make good of the damaged Works. Should the Contractor fail to do so within period specified after receipt of written request to do so from the JICA, the JICA shall have the right to employ another Contractor to carry out such work and the Contractor agrees to bear all expenses incurred.

Article 12 Discrepancies among the Contract Documents

If, prior to or during the course of the Works, any discrepancies are found in the drawings and/or the Technical Specifications etc. attached to this Contract, the Contractor shall follow the ruling given by the Inspection Committee at no additional cost to the JICA.

Article 13 Construction Method and Temporary Works

The construction method including implementation schedule and plan of the temporary works such as installation of temporary facilities, offices, ware houses, construction roads, electric wiring, etc. shall be submitted by the Contractor and approved by the Inspection Committee at least 10 (ten) days in advance of the commencement of the Works.

Should the cost of the above temporary works be estimated in the unit cost of each work items of Bill of Quantities in this Contract, the Contractor is not entitled to claim any amount of charges for the temporary works.

Article 14 Modification of Plant

If the Inspection Committee finds it necessary to make modification of construction design and/or materials and so forth during the course of construction, the JICA has the right to order the modification of the Works to the Contractor, and such order shall be made in writing from the Inspection Committee to the Contractor.

The JICA agrees to adjust upwards or downwards the necessary expense for such modification to the Contractor, which will be estimated by unit price in the Bill of Quantities of this Contract in case of modification of quantities of construction works.

In the case of additional works which are not quoted by unit price in the Bill of Quantities of this Contract, the Inspection Committee will make estimation thereof and the JICA will pay to the Contractor for such additional works accordingly. But if the Contractor does not agree to such estimation, the Contractor is then entitled to negotiate with the JICA. Also the extension of the completion time due to the modification shall be given by the JICA who shall have the sole right to decide the number of days of such extension.

Article 15 Acceptance of the Works

When the entire Works have been completed, the Contractor shall submit the invoice in written form indicating the Work actually completed to the Inspection Committee. If there are compliance with drawings or Technical Specifications, the JICA shall accept the Works as the final acceptance of satisfactory completion Works within ten (10) days after the receipt of the written form and it shall be deemed that the final acceptance has been made on such date of the receipt of the written form.

On the other hand, should non-compliance with drawings or Technical Specifications or defects be found in the Works executed by the Contractor, the Inspection Committee will have the right not to accept the Works and to order the rectification of the Works. If the required period for the rectification of the Works is beyond the completion date, the Contractor shall not be relieved from its responsibility to pay the penalty as stipulated under clause 5.3, and after the completion of rectification of the Works, then the final acceptance will be made in the same manner as described in the first paragraph of this Article.

During the course of construction, whether in the completion time or of extended time specified in the last paragraph of Article 4, the JICA has the right to accept a part of the Works already completed in the written form which shall be considered as a part of final acceptance. However, both parties shall negotiate with each other for the maintenance and usage of the accepted part of the Works, and the Contractor is not entitled to request the extension of the completion time due to any interruption caused by the use of such accepted Works by Kasetsart University, the JICA, the Inspection Committee or the officers of Thai Government authorities, or any delay in repairing such accepted Works.

Article 16 Construction Engineer

The Contractor shall appoint a construction engineer at his own expense for the supervision of the Works performance, who shall be authorized to act on behalf of the Contractor, and the instructions given to him shall be deemed as given to the Contractor. Such construction engineer shall be a well English-speaking person and accepted by the JICA, who shall stay at the job site all the time and shall not leave without obtaining the prior approval of the Inspection Committee. If the Contractor replaces the construction engineer, the Contractor shall obtain the prior approval from the Inspection Committee in writing.

Article 17 Replacement of Labour, Engineer and Foreman

The Inspection Committee may request the Contractor to remove any of the Contractor's labours, foremen or engineers if it appears to the Inspection Committee that such labour, foreman or engineer is incompetent for his job or is not suitable or is not capable of handling his workmen or staff, and the Contractor shall promptly replace any such labour, foreman or engineer. No extra cost or claim for extension of time will be allowed because of such replacement.

Article 18 Sub-Contractor

The Contractor shall not sub-contract or assign any portion of the Works under this Contract without obtaining the prior approval of the JICA who has the sole right to decide which portion of the Works may be sub-contracted or assigned to the Sub-Contractor. However, the Contractor shall be fully responsible for the Works done by the Sub-Contractor.

Article 19 Notice

All notices required by this Contract shall be effective only at the time of receipt thereof, and only when received by the parties concerned at following address:-

The JICA Bangkok Office, 1674/1 New Petchburi
Road, Bangkok 10310

The Contractor

All Notices required by the terms of this Contract shall be made in writing in English Language, and delivered by registered mail or hand delivery.

Article 20 Dispute

In the event of any dispute arising from the interpretation and performance of the terms of this Contract, both parties agree to make the best attempt with sincerity and in good faith to negotiate and amicably settle such dispute, failing which the parties agree to refer such dispute to arbitration under Thai Commercial Arbitration Rules and Regulation, Bangkok, by 2 arbitrators, each of which is to be appointed by each party. If either party fails to appoint its arbitrator within seven (7) days or should the arbitrators fail, within fifteen (15) days after their appointment, to agree upon the decision of the dispute or no decision is reached on the appointment of an umpire, then the dispute shall be brought before the Court of Thailand for decision under the laws and procedures of the Kingdom of Thailand.

This Contract is executed in duplicate of the same tenor, one of the original copy to be kept by JICA and the other original copy to be kept by the Contractor. Both the JICA and the Contractor have set their signatures and affixed the seals thereto in the presence of the witnesses.

JICA

Mr. _____, Director, Bangkok Office,
Japan International Cooperation Agency.

Contractor

Witness

Witness

TECHNICAL SPECIFICATIONS

FOR

CONSTRUCTION OF MODEL INFRASTRUCTURE IMPROVEMENT WORK

on

STRENGTHENING RESEARCH ACTIVITIES

PHASE II PROJECT

AT

KASETSART UNIVERSITY

KAMPHAENSAEN CAMPUS

BANGKOK OFFICE

JAPAN INTERNATIONAL COOPERATION AGENCY

TS-1

TECHNICAL SPECIFICATIONS

PART 1 SPECIAL PROVISION

1-01 The Contractor shall exercise utmost care so that his construction operations will not damage any existing structure except such structures as specified to be dismantled, or will not cause the disturbances not only on the operation of the Kasetsart University (the University) but also on the cultivation land of the other project. Any damages on the such existing structure or facilities shall be made good by the Contractor at his expense.

1-02 If it is necessary in the prosecution of the work to interrupt or obstruct the drainage of the surface, the flow of artificial drains and the flow of irrigation canal, the Contractor shall provide for the same during the progress of the work in such a way that no damage shall result to either public or private interest. For any neglect to provide for either natural or artificial irrigation or drainage which he may interrupted, he shall be held liable for all damages which may result therefrom during the progress of the work.

1-03 The Contractor is expected to visit the location of the work and make his own estimate of the facilities needed for the work. In the successful execution of the contract, the Contractor is expected to familiarize himself with local conditions, availability of labor, transportation facilities, uncertainties of weather, and other contingencies. From investigations, made at site, it is believed that topographical conditions are approximately shown on the drawings, but the nature of the materials and the depth of satisfactory foundations, are not guaranteed. It is expressly understood that JICA will not be responsible for any deduction, interpretation, or conclusions made by the Contractor. JICA does not guarantee that other materials will not be encountered or that the proportions of the several materials will not vary from those indicated by the drawings.

1-04 Elevation referred to the datum plane are to be determined from bench marks established by JICA or the Inspection Committee at the site of the work.

1-05 The Inspection Committee will establish the necessary survey monuments and bench marks at convenient points in the area covered by this contract for use of the Contractor in laying the lines and grades required for the proper conduct and execution of the work. All stakes, bench marks, etc., placed by the Inspection Committee in

laying out the work, shall be carefully guarded and preserved by the Contractor, and in such case stakes or marks are misplaced or rendered useless through the carelessness or negligence of the Contractor or his agents, employees or workmen, they will be replaced by the Inspection Committee at the expense of the Contractor.

1-06 The Contractor shall execute the work to the lines and grades given by the drawings and/or the Inspection Committee. The Contractor shall, at his own expense, furnish all stakes, templates, patterns, platforms and labor that may be required in setting or laying out any part of the work.

PART 2 GENERAL CONSTRUCTION FACILITIES

2-01 SCOPE

This part covers the construction and/or maintenance of access roads, setting up of Contractor's camp facilities, providing camp security and the disposition of the Contractor's various facilities at the end of the contract.

2.02 ROADS

(a) The Contractor shall improve, repair and widen, if necessary, existing roads to satisfactorily meet his haulage requirements. he shall also construct all other roads within the construction area which he deems necessary in the prosecution of his work. The improving, widening and maintaining of existing roads and constructing and maintaining new roads shall be made without cost to JICA, and same shall be made on the responsibility of the Contractor during and up to the completion of all construction work under the contract.

2-03 CONTRACTOR'S CAMP FACILITIES

(a) If the Contractor deems necessary, he shall grade his camp site; construct his office, employees' housing, warehouses, machine and repair shops, fuel storage tanks; and provide such other facilities that the Contractor deems necessary for maintaining health, peace and order in the camp and work area.

(b) The location, construction, operation and maintenance of such camps and facilities within the areas of the University Campus shall be subject to the approval of the Inspection Committee. At least ten (10) calender days prior to the date on which the Contractor desires to begin to work in feature of camp construction, the Contractor

shall submit for the approval of the Inspection Committee drawings and specifications, in sufficient detail to permit determination of suitability of the construction in compliance with these specifications, and no camp construction of any kind shall be undertaken until such drawings and specifications have been approved by the Inspection Committee.

2-04 CAMP SECURITY

The Contractor shall provide his own security force to the extent that he deems necessary for maintaining peace and order in the camps and work areas and to safeguard materials and equipment.

2-05 DISPOSITION OF CAMP AND CONSTRUCTION FACILITIES

After the completion of the work covered by the Contract, the entire camp of the Contractor, including its water supply system, quarters, warehouses, shops and other facilities therein; and all other temporary installations at work areas shall be removed by the Contractor and the site shall be cleaned.

2-06 PAYMENT

There will be no separate payment for complying with the requirements of this part. The expenses incurred by the Contractor shall be included in the item of Common Temporary Works as indicated in the Priced Bill of Quantity.

PART 3 CARE OF WATER DURING CONSTRUCTION

3-01 SCOPE

In accordance with specifications contained in this part, the Contractor shall care the water during construction so that construction work can be performed in areas free from water. Care of water during construction shall include provision for drainage and pumping system for dewatering the foundation areas and the construction of temporary bulkheads necessary for the protection of construction operations from encroachment by water.

3-02 DRAINAGE AND PUMPING

The Contractor shall be responsible for dewatering the foundation areas so that work may be carried on in a suitable dry condition, draining and/or pumping all water during the process of construction until its completion. The Contractor shall construct drainage ditches, holes, or culverts; furnish, operate, and maintain at his own expense all necessary pumps, to keep all work areas in amply dry condition, and prior to final acceptance of the work by the Contracting Officer, the Contractor shall remove, fill or plug all temporary drainage structures and pumping equipments at his expense.

3-03 PAYMENT

No separate payment shall be made for the care of water during construction. But the cost of furnishing, constructing, operating, maintaining, and removal of temporary drainage structures, canals, and pumping system necessary to keep construction operations free from water shall be included in item of Common Temporary Works as indicated in the Priced Bill of Quantity.

PART 4 OPEN EXCAVATION AND FOUNDATION PREPARATION

4-01 SCOPE

In accordance with the Specifications, contained in this part, and as shown on the drawings, or otherwise directed by the Inspection Committee, the Contractor shall perform all required open excavation and foundation preparation pertinent to the construction of land levelling, farm road, irrigation canal, drainage canal, and other construction work where open excavations are to be made.

4-02 OPEN EXCAVATION

(a) General

Open excavation under these Specifications consists of the removal, hauling, dumping, and satisfactory disposal of all materials from required excavations for farm road, irrigation and drainage canals and miscellaneous excavations for other structures included under this contract. Open excavation shall be performed to the lines and grades shown on the drawings or established by the Inspection Committee. The Inspection Committee may modify slopes of excavation to fit conditions encountered during construction. Such changes or modifications shall not be considered by the

Contractor as a basis for additional compensation over and above the unit prices bid. All necessary precautions shall be taken to preserve the ground outside the specified lines and grades in the soundest possible condition.

(b) Foundation in Loose Material

When the surfaces of excavation upon or against which concrete or embankment fill is to be placed consist of loose material, the said loose materials shall be removed or replaced with suitable materials and compacted in a manner satisfactory to the Inspection Committee. The cost of removing the loose materials shall be paid for under the pertinent bid items for open excavation. The cost for the replacement with suitable materials and the compaction of the same shall be paid for under the pertinent bid items for fill.

4-03 DISPOSITION OF EXCAVATED MATERIALS

(a) Spoil Areas

The Contractor shall submit for the approval of the Inspection Committee locations, areas, drawings and other necessary specifications of spoil area which the Contractor proposes to use for the work under this Contract, and any kind of disposition shall not be undertaken before obtaining the said approval. Excavated material not suitable for fill or otherwise not needed shall be wasted in approved spoil area. Spoil piles shall be constructed to the stable slopes of the material being wasted. Any spoil pile exceeding two (2) meters in height shall not be performed. Spoil material shall be spread and graded so that surface drainage will not be concentrated and will not create and/or accelerate undesirable erosion in spoil areas.

4-04 DEMOLITION, REMOVAL, AND DISMANTLING

When specified in the drawing or the Inspection Committee, existing concrete structures, such as concrete masses, stones, etc., shall be demolished and disposed of accordingly.

4-05 FOUNDATION PREPARATION

(a) Fill on Earth

All horizontal and sloped earth surfaces, upon which embankment material is to be placed or other foundation surfaces whose locations are specifically indicated by the Inspection Committee, shall consist of undisturbed or compacted material and shall be

clean, damp, free from standing or running water and free from organic matter; and shall be suitable as a foundation for the material to be placed upon them.

(b) Concrete

All horizontal and sloped earth surfaces upon which concrete is to be placed shall be undisturbed or of approved compaction, clean and damp, free from standing or running water, and shall be otherwise suitable as a foundation for the concrete to be placed upon them.

4-06 MEASUREMENT FOR PAYMENT

(a) Open Excavation

A survey of the areas to be excavated shall be made by the Contractor prior to the commencement of the work under this contract, and all measurements of excavation shall be based on this survey without regard to any change that may occur during the prosecution of the work. All such surveys shall be the subject to check and approval by the Inspection Committee. Volumes will be computed and shall be the amount between the original ground determined by the survey and the slopes, lines and grades shown on the drawings or established by the Inspection Committee.

(b) Foundation Preparation]

No separate payment will be made for all foundation preparation specified under Paragraph 4-05, (a). The entire cost of foundation preparation for 4-05 (a), shall be included in the unit price for the pertinent item of embankment or fill in the Bill of Quantity. The cost of foundation preparation specified under Paragraph 4-05 (b), shall be paid for under the pertinent item shown in the Bill of Quantity, and the measurement shall be made by the acceptable method to the Inspection Committee.

(c) Demolition, Removal and Dismantling

Demolition, removal and dismantling work will be measured by the acceptable method to the Inspection Committee and paid for under the items shown in the Bill of Quantity.

PART 5 FILL AND BACKFILL

5-01 SCOPE

In accordance with the specifications contained in this part and as shown in the drawings or otherwise directed by the Inspection Committee the Contractor shall furnish and place the earth fill for land levelling, farm road embankment and for irrigation and drainage canal embankment; backfill for related structures. Any work of fill and backfill shall not be commenced without prior approval of the Inspection Committee. The slope of the embankment shall be finished to the designed gradient by providing fixed rules.

5-02 BACKFILL

Backfill, as used herein, is defined as refill for structures. The materials used for backfill for structures shall be free from roots, stones of more than five (5) centimeters in diameter, and other objectionable materials and subject to the approval of the Inspection Committee. Backfill materials shall be placed in layers, each layer being not more than twenty (20) centimeters thick before compaction, thoroughly compacted by means of power tampers or by other means of approved by the Inspection Committee.

5-03 FILL

(a) Lines and Grades

The fills shall be constructed to the lines, grades and cross sections indicated on the drawings, unless otherwise directed by the Inspection Committee. The Inspection Committee may increase or decrease the slopes of the fill or make such other change in the design as may be deemed necessary to produce a stable structure. Change in quantities of materials, resulting from prescribed changes in section, shall not make cause for claims for increased unit prices. Generally, a tolerance of plus or minus 0.05 meter from the slope lines and grades shown on the drawings will be allowed in the finished surfaces of the embankments except that the tolerances shall not be continuous over an area greater than twenty (20) square meters.

(b) Conduct of the Work

1. The Contractor shall maintain and protect the fills in a satisfactory condition at all times until final completion and acceptance of all work under the Contract. Any approved fill material which is rendered unsuitable after being placed in

the fills shall be replaced by the Contractor and no additional payment will be made there. The Contractor shall excavate and remove from the fills any material which the Inspection Committee considers objectionable and shall also dispose of such material and refill the excavated as directed, all at no additional cost to JICA. The Contractor may be required to remove at his own expense any fill material placed outside of prescribed slope lines.

2. When the excavation of suitable fill material from required excavation and approved borrow sources progresses at a faster rate than placement in the fills, such excavated materials may be stockpiled at approved locations until use is authorized. No separate payment will be made for stockpiling or reloading and hauling of this material to its place in the fills and all costs in connection therewith shall be included in the applicable contract unit price for the fill materials.

5-04 MATERIALS

(a) Sources

The Contractor shall submit for the approval of the Inspection Committee locations, areas, drawings and other necessary specifications of borrow areas which the Contractor proposes to use for obtaining fill material. Materials for fills shall be secured from required excavations and from the borrow areas as approved. There is no guarantee that all the materials in any borrow area will be suitable for use in the fills and the Contractor shall move or modify his operations to avoid unsuitable material. The Contractor shall maintain and operate sufficient excavating and hauling equipment so that an adequate amount of fill material from all sources is available as required. Operations in borrow areas shall not be on danger roads, building, or structures. Borrow areas shall be graded to provide drainage from all parts of the excavated areas. When operations in a borrow area have terminated, the area shall be dressed to a neat and orderly appearance, as approved by the Inspection Committee. Any additional material needed shall be obtained from sources approved by the Inspection Committee.

(b) Suitability

Materials containing brush, roots, sod or other perishable material will not be considered suitable for fills. The suitability of the materials shall be subject to the approval of the Inspection Committee.

5-05 PLACEMENT

(a) General

No fill material shall be placed on any part of the fill foundations until such areas have been inspected and approved by the Inspection Committee and until after completion of foundation preparation as specified in PART 4. The gradation and distribution of materials shall be such that the fills will be free from lense, pockets, and streaks.

(b) Earth Fill

The fill material shall be dumped and spread in horizontal layers having an uncompacted thickness of not over 20 cm. When material is spread, chunks larger than 10 cm in size shall be broken down by approved means or removed.

5-06 COMPACTION

(a) General

After a layer of fill material has been dumped and spread, it shall be compacted by hand operated mechanical tampers or by other compaction machine approved by the Inspection Committee, to a density more than 85 percent of the maximum dry density of the material or to a density specified by the Inspection Committee.

(b) Fill on or against Culverts and Concrete Structure

No fill shall be placed on or against concrete surface before a period of fourteen days has elapsed after placing the concrete. Before passage of hauling equipment over the top of culverts or other structures will be permitted, the depth of fill over the concrete shall be sufficient to permit such passage without harmful stresses or vibrations in the structure. Fill placed around and over culverts or other structures shall be compacted by hand operated mechanical tampers or by man power to a density equal to that specified for the other earth fill.

5-07 ADDITIONAL COMPACTION

If, in the opinion of the Inspection Committee, the desired compaction of portion of the embankment is not secured, additional compaction operation shall be made over the surface area of such designated portion until the desired compaction has been obtained, without additional cost to JICA.

5-08 QUALITY CONTROL

If it is required, tests, for moisture content and density, all necessary tests will be made by the Inspection Committee, and from these tests, corrections, adjustments, and modifications of methods, materials, and moisture contents may be made in order to secure satisfactory density of the fill materials. The Contractor shall provide necessary unskilled labor in obtaining and preserving samples.

5-09 MEASUREMENT FOR PAYMENT

(1) Fill

(a) Measurement

Measurement for payment of fill will be calculated on the number of cubic meters of material placed between the foundation lines as determined on the basis on drawings or a survey made after completion of the excavation and foundation preparation and the lines, grades and slopes shown on the drawings. No allowance will be made for foundation or embankment settlement.

(b) Payment

Payment shall constitute full compensation for all work in connection with the excavation from borrow areas including clearing, grubbing and stripping of borrow areas, hauling, stock-piling, rehandling, foundation preparation, placing, spreading, sprinkling, drying, breaking up, compacting, removal of objectionable material, and all other work required for the construction, protection and maintenance of the fills. No adjustment in payment will be made for substitution of materials and for additional compaction

(2) Backfill

Measurement for payment of backfill shall be calculated on the number of cubic meters of materials placed among the original ground line, or designated line of backfill and the structure and the neat pay lines of excavation shown in the drawings. Payment will be made on the unit price bid per cubic meter of backfill.

PART 6 LAND CONSOLIDATION

6-01 SCOPE

The land consolidation involves such kinds of construction works as earth works, and concrete works in connection with the construction of land shape adjustment, land levelling, farm road, irrigation and drainage canals and appurtenant structure. It is considered: that earth works for the land consolidation such as open excavation, foundation preparation and earth fill shall be performed by the Contractor in accordance with the Specification indicated in PART 4 and PART 5 and concrete works for the land consolidation such as pavement and placing of concrete shall be carried out by the Contractor based on the Specification described in PART 6 and PART 7. Under the circumstances stated above, the Specifications contained in this part shall prescribe the rules and matters, for which special attention shall be taken by the Contractor from the view-point of the execution for each of the construction work on the land consolidation.

6-02 GENERAL

(a) Preparation of Construction

Prior to the commencement of construction works for the land consolidation, an attention shall be taken on interception of the excess rain water drained from the outside area of the experimental field so that the excess rain water will not flow into the area of the experimental field and then the construction works for the land consolidation shall be executed under a dry condition that the surface water on the experimental field has almost been eliminated from the ground.

(b) Procedure of Construction Work

The construction works for the land consolidation should commence fundamentally from the work of land levelling including land shape adjustment firstly and continue in due course with the work of farm road, drainage canal and irrigation canal.

6-03 LAND SHAPE ADJUSTMENT AND LAND LEVELLING

(a) Land Levelling

The construction of land levelling including land shape adjustment shall be prosecuted by taking the following procedure, as a standard type of the construction for land levelling;

Cut and earth fill - Land shape adjustment - Land levelling

(b) Elimination of Pebbles, Stumps and Others

Gravels, pebbles, stumps, roots and the other organic materials, those are obstructive substances for the cultivation of the land shall be disposed either by burying them into the ground up to a depth, under which the land cultivation would not be affected by them or by carrying them out to the spoil areas.

(c) Exclusion of Water Accumulated

In the case that there are water accumulated in the depression and are water stayed in the existing drainage channel, the Contractor shall be responsible for dewatering the depression as well as the existing drainage channel so that the earth fill for both the depression and the existing drainage channel may be carried out in a suitably dry condition, draining all water during the process of the construction until its completion.

(d) Cut and Earth Fill of Land

The earth materials necessary for embankment of the lower land in elevation shall be provided with those excavated from the higher land in elevation within the experimental field. For formulating the levelling, the elevation of each plot in the experimental field after a completion of the land levelling, has been decided by taking such a way as the volume of earth materials necessary for the embankment would have well-balanced, as a whole, with those excavated.

(e) Prevention for Settlement of Embankment

The special care shall be taken on the embankment works for such areas as a settlement of the embankment would be anticipated even a little after a completion of the work, in order to keep a settlement of the embankment as small as possible. The Contractor shall be liable to pay attention on the embankment works for the depression as well as for the area where the height of embankment would be comparatively high.

(f) Erection of Foot Path

The foot path shall be constructed with well compaction of earth fill materials to the lines, grades and cross sections indicated on the drawings, unless otherwise directed by the Inspection Committee.

(g) Final Arrangement of Land

The arrangement of land for each plot in the experimental field shall be finalized to the lines and grades shown in the drawings so as to not disturb the cultivation of the experimental field.

6-04 FARM ROAD

(a) The farm road shall be constructed by using earth materials graded well from fine particle to coarse particle and be completed by compaction with hand operated mechanical tampers after a layer of fill material has been dumped and spread.

(b) The surface of farm road shall be finalized by constructing middle portion of the road higher in height than each side of the road, of which the cross sectional gradient is shown in the drawings.

(c) During the period of construction for farm road, the Contractor will always pay attention on drainage of rain water to prevent the surface of road from becoming muddy.

6-05 IRRIGATION AND DRAINAGE CANALS

(a) The embankment along the irrigation canal and the drainage canal shall be constructed by using earth materials not containing previous particles such as sands and pebbles and by taking compaction of the earth materials for each lay of the embankment in order to prevent seepage through the cross section of the embankment, and shall be completed to the lines, grades and the designed shape indicated on the drawings, unless otherwise directed by the Inspection Committee.

(b) The turn-outs shall be erected at the locations shown in the drawings, unless otherwise directed by the Inspection Committee.

PART 7 CONCRETE WORKS

7-01 SCOPE

In accordance with the Specifications contained herein and as shown on the detail drawings or otherwise directed, the Contractor shall -

- (a) Furnish all materials, and manufacture, transport, place, finish, protect and cure concrete;
- (b) Furnish, construct, erect and dismantle forms;
- (c) Construct expansion and contraction joints and furnish and place waterstops, joint fillers, and sealing compound, if required; and
- (d) Prepare, clean, cut, bend and place steel reinforcement.

7-02 CEMENT

(a) General

Cement for mortar and concrete work shall be Portland Cement which conforms to the requirements of the Standard Specifications for Portland Cement (A.S.T.M. Designation C150-69).

(b) Storage

Cement shall be stored in a dry, weather tight and properly ventilated warehouse with adequate provisions for the prevention of absorption of moisture. All storage facilities shall be subject to approval and shall be such as to permit easy access for inspection and identification. Cement which has been stored for more than one month or which is suspected to be damp shall not be used unless otherwise approved by the Inspection Committee.

7-03 FINE AGGREGATE

(a) Composition

Fine aggregate shall be natural sand not including organic matter and other foreign substances.

(b) Quality

Fine aggregate shall consist of hard, tough, durable, uncoated particles. The shape of the particles shall be generally rounded or cubical and reasonably free from flat or elongated pieces. The fine aggregate shall conform to the following specific requirements:

1. Grading - Fine aggregate shall be well graded from fine to coarse and the gradation shall conform to the following requirements as delivered to the mixers:

<u>Sieve Designation</u>	<u>Cumulative Percentage</u>
<u>U.S. Std. Square Mesh</u>	<u>by Weight Passing</u>
No. 4	95 - 100
No. 16	60 - 75
No. 100	2 - 10

In addition to the grading limits shown above, the fineness modules shall be in the range from 2.30 to 3.00.

(c) Storage

Fine aggregate shall be stored in such a manner as to avoid the inclusion of any foreign material in the concrete. Sufficient live storage shall be maintained at all times to permit continuous placement of concrete at the rate specified.

7-04 COARSE AGGREGATE

(a) Composition

Coarse aggregate shall consist of gravel, crushed gravel or rock, or a combination of gravel and crushed gravel or rock.

(b) Quality and Grading

1. Quality - Coarse aggregate shall consist of hard, tough, durable, clean and uncoated particles. All foreign materials and dust shall be removed by adequate processing. The particle shape of the smallest size of crushed coarse aggregate shall be generally rounded or cubical, and the coarse aggregate shall be reasonably free from flat and elongated particles in all sizes.

2. Grading - The coarse aggregate shall be well graded from fine to coarse. The grading of the aggregate as delivered to the mixer shall be as follows:

Sieve Designation <u>U.S. Std. Square Mesh</u>	Per Cent by Wt. Passing Individual Sieves <u>3/4" Max.</u>
1 "	100
3/4 "	90 - 100
3/8 "	20 - 50

3. Size - Unless otherwise directed, the maximum sizes of coarse aggregate to be used in the various parts of the work shall be 3/4 inch.
4. Storage - Storage of coarse aggregates shall be as that specified in Paragraph 7-03 (c) for fine aggregates.

7-05 AGGREGATE SAMPLES

Samples of the aggregate shall be furnished at a point designated by the Inspection Committee for his approval at least ten (10) days in advance of the time when the placing of concrete is expected to begin.

7-06 WATER

Water used in mixing concrete shall be fresh, clean and free from injurious amount of oil, acid, alkali, salts, or organic matter.

7-07 PROPORTIONING OF CONCRETE

(a) The Contractor shall design the mix proportion for every class of concrete placing for the approval of the Inspection Committee. The Contractor shall carry out the mix test in case of being requested by the Inspection Committee. The test is to be made at the expense of the Contractor.

(b) The compressive strength of the age of 28 days shall be as follows and desirable mix proportion is also indicated.

<u>Class</u>	<u>Minimum 28 days Compressive strength</u>	<u>Mixing proportion by volume cement: fine aggregates: coarse aggregates</u>
A (Reinforced concrete)	210 kg/cm ²	1 : 2 : 3
B (Plain concrete)	160 kg/cm ²	1 : 2 : 4
C (Concrete layer)	135 kg/cm ²	1 : 3 : 4

Other proportions for mixed design may be indicated by the Inspection Committee at the site of work, if it is necessary.

7-08 MIXING

(a) Equipment

Concrete shall be mixed by portable concrete mixer unless otherwise approved by the Inspection Committee.

(b) Measurement

The measurement of every ingredient of concrete shall be made in weight. Nevertheless, the measurement in volume is admitted subject to the approval of the Inspection Committee.

(c) Mixing Time and Method

The mixing time of concrete shall be more than two (2) minutes and less than five minutes. Over mixing, requiring the introduction of additional water to preserve the required consistency, will not be permitted. The mixer shall be completely emptied before receiving the materials for the succeeding batch and shall be kept clean and washed out after stopping work at the end of each shift.

On commencing work, the first batch shall contain sufficient excess of cement, sand and water to coat the inside of the drum to avoid the reduction of the required mortar content of the mix.

7-09 CONVEYING

(a) General

Concrete shall be conveying from mixer for forms, as rapidly as practicable, by methods which will prevent segregation or loss of ingredients. There shall be no vertical drop greater than 1.5 meters except where suitable equipment is provided to prevent segregation and where specifically authorized. Belt conveyors, chutes or other similar equipment in which the concrete is delivered to the structure in a thin, continuously exposed flow, will not be permitted except for very limited or isolated sections of the work. Such equipment shall be arranged to prevent objectionable segregation.

7-10 PLACING

(a) Approval

Approval of the Inspection Committee shall be obtained before starting any concrete pour.

(b) General

Concrete shall be worked into the corners and angles of the forms and around all reinforcement and embedded items without permitting the material to segregate. Not more than three (3) cubic meters shall be deposited in one pile for compaction. Free water shall be collected in depressions away from the forms and removed by bailing prior to placement of additional concrete. All concrete placing equipment and methods shall be subject to approval.

(c) Cooling of Aggregates

The aggregate shall be cooled by wetting if it is drier than the condition known as saturated, surface dry.

(d) Concrete on Earth Foundation

All concrete shall be placed upon clean, damp surface free from standing or running water. Prior to placing concrete, the earth foundation shall be satisfactorily compacted in accordance with approved methods.

(e) Concrete on Other Concrete

Surface upon or against which concrete is to be placed shall be clean, free from oil, standing or running water, mud, drummy rock, objectionable coatings, debris, and loose, semidetached or unsound fragments. To insure a firm and tight bond between fresh concrete and other concrete, concrete surfaces, wherever necessary, shall be chipped or roughened as directed by the Inspection Committee. All surfaces shall be wetted thoroughly to keep them in a completely moist condition before placing concrete. All approximately horizontal surfaces shall be covered with a layer of mortar of the same cement-sand ration as used in the concrete mix before the concrete is placed.

7-11 FORMS

(a) General

Forms shall be used, wherever necessary, to confine the concrete and shape it to the required lines, or insure against contamination of the concrete. Forms shall have sufficient strength to withstand the pressure resulting from placement and vibration of the concrete, and shall be maintained rigidly in correct position. Forms shall be sufficiently tight to prevent loss of mortar from the concrete. Forms for exposed surfaces against which backfill is not to be placed shall be lined with a form grade plywood or sheet steel. Steel panel forms may also be used.

(b) Cleaning and Oiling of Forms

At the time concrete is placed in the forms, the surfaces of the forms shall be free from incrustations of mortar, grout, or other foreign material that would contaminate the concrete or interfere with the fulfillment of the Specifications' requirements relative to the finish of formed surfaces. Before concrete is placed, the surfaces of the forms shall be oiled with a commercial form oil that will effectively prevent sticking and will not stain the concrete surfaces.

(c) Removal of Forms

Forms shall be removed as soon as practicable in order to avoid delay in curing and to make possible earliest practicable repair of surface imperfections, but in no case shall they be removed before approval. Any needed repair or treatment shall be performed at once, and shall be followed immediately by the specified curing. Forms shall be removed with care so as to avoid injury to the concrete, and any concrete so damaged shall be repaired.

7-12 CURING AND PROTECTION

(a) General

All concrete shall be moist cured for a period of not less than seven (7) consecutive days by an approved method or combination of methods applicable to local conditions, except that the curing period may be reduced to three days for concrete made with high-early-strength cement. The Contractor shall have all equipment needed for adequate curing and protection of the concrete on hand and ready to install before actual concrete placement begins.

(b) Water Curing

Concrete shall be kept wet by covering with an approved, watersaturated material or by a system of perforated pipes or mechanical sprinklers or by any other approved method which will keep all surfaces continuously (not periodically) wet. Water for curing shall be generally clean and free from any element which might cause objectionable staining or discoloration of the concrete.

7-13 REPAIR OF CONCRETE

Repair of imperfections in formed concrete shall be completed within twenty four (24) hours after removal of forms at no additional cost to JICA. Forms shall be neatly removed from exposed surfaces. Concrete that is damaged or honeycombed must be removed to sound concrete and replaced with drypack, mortar, or concrete as hereinafter specified. Where large bulges and abrupt irregularities protrude, the protrusions shall be reduced by bush-hammering and grinding. Drypack filling shall be used for holes left by the removal of fasteners from the ends of form tie rods.

7-14 DAYPACK MORTAR

Drypack shall consist of a mixture (by dry volume or weight) of one (1) part cement to 2-1/2 parts of sand conforming to Paragraph 7-03, Fine Aggregate, except that in gradation, 100% shall pass a No.16 sieve. Only enough water shall be used to produce a mortar which, when used, shall stick together on being molded into a ball by a slight pressure of the hands, and shall not extrude water but will leave the hands damp.

7-15 STEEL REINFORCEMENT

(a) General

The Contractor will furnish all steel reinforcement in accordance with the drawings and these specifications. The Contractor shall prepare, clean, cut, bend and place all reinforcements, as shown on the detail drawings or as otherwise directed. The Contractor shall furnish all chains, supports and ties. All reinforcement shall be reasonably free from loose, flaky rust and scale, and free from oil, grease and other coating which might destroy or reduce its bond with concrete.

(b) Relationship of Reinforcement to Concrete Surfaces

The distance from the edge of the main reinforcement to the concrete surface shall be 5 cm except such portions as shown in the drawings. The concrete covering the stirrups, spacer bars, and similar secondary reinforcement may be reduced by the diameter of such bars, unless otherwise indicated.

(c) Lapping

Lapping length at joints of the reinforcing bar shall be at least thirty times of the diameter of bar and shall be bound by steel wire.

(d) Supports

All reinforcements shall be secured in place by use of metal or concrete supports, spacers or ties. Such supports shall be of sufficient strength to maintain the reinforcement in place throughout the concreting operation. The supports shall be used in such a manner that they will not be exposed or contribute in any way to the discoloration or deterioration of the concrete.

7-16 MEASUREMENT FOR PAYMENT

(a) Concrete

1. Measurement for payment for plain or reinforced concrete, will be based on the volume of concrete in place within the lines and grades shown on the drawings.
2. No deduction will be made for rounded or bevelled edges, or space occupied by metal work, or embedded items such as supports, spacers or ties. The cost of construction joint treatment with the attendant loss of material shall be included in the unit price bid per cubic meter of concrete.
3. Payment at the unit prices bid shall constitute full payment for all costs for concrete work. The costs of any dewatering required to maintain dry conditions during the pouring of concrete, furnishing materials, and installing and removing formwork, shall be included in the unit cost.

(b) Steel Reinforcement

Measurement for payment for furnishing, preparing bar cleaning, cutting, bending, and placing steel reinforcement by the Contractor will be based on the number of kilograms placed in accordance with the detail drawings or as otherwise directed. Payment will be made for steel in laps as shown on the drawings; where bars are welded, payment will be made as if they were lapped. Payment will not be made for steel in laps or used which are solely for the convenience of the Contractor. Payment will be made at the unit price bid for steel reinforcement. No separate payment will be made for steel reinforcement supports, and the cost thereof shall be included in the unit price bid.

PART 8 OTHER RELATED CONSTRUCTION WORKS

8-01 GENERAL

The land consolidation works for the experimental field include under this contract construction works for appurtenant structure besides main construction works such as the construction of land shape adjustment, land levelling, farm road and irrigation and drainage canals.

The said appurtenant structures comprise, diversion facilities, turn-outs, culverts, etc.

The majority of the appurtenant structures shall be concrete structure, which shall be constructed by means of the combination of earth work and concrete work. It means that the Specification indicated in the PART 4, 5 and 7 shall be adaptable for the construction of the appurtenant structure.

From the view-point stated above, the Specification contained in this part describes only size, shape, features and quantity with respect to each of the appurtenant structures.

8-02 DIVERSION FACILITY AND TURN-OUT

(a) The diversion facility shall be made of concrete with one meter in width and one meter in length and be constructed having wooden weir plate each at different locations as it seen the drawings.

(b) Turn-out shall be installed with concrete at the location designated on the drawings.

8-03 CULVERT

(a) The culvert shall be provided with concrete structure on the both irrigation canal and drainage canal at the place wherever both the canals meet with farm road. The section and length of the culvert is different as is seen in the drawings.

PROPOSAL

To: Mr.
The Resident Representative
Japan International Cooperation Agency, Bangkok Office
c/o Embassy of Japan

P-01 BILL OF QUANTITIES AND BID PRICES

The undersigned Bidder having carefully examined in their entirety the Contract Documents for the Construction of Model Infrastructure on the Strengthening Research Activities Phase II Project, hereby offers and proposes to perform all of the construction and services, to furnish all equipments, materials, supplies, labor and other items described in the Contract Documents, all for the unit or lump sum prices stated in words and figures in the following Quantities:

- Bill of Quantities to be attached herein -

P-02 GUARANTEE OF COMPLETION

The undersigned Bidder guarantee to effect the commencement, prosecution and completion of the Contract Works.

P-03 BID SECURITY

I hereby certify that all statements herein are made on behalf of

_____ ; Dated this _____ day of _____
1985.

Title _____

Firm's Address _____

WITNESS

Appendix

I. TABLE LIST

No.	TITLE
1	MONTHLY MEAN AIR TEMP (AVERAGE)
2	MONTHLY MEAN HUMIDITY (AVERAGE)
3	MONTHLY MEAN WIND VELOCITY
4	AVERAGE MEAN MONTHLY RAINFALL DISTRIBUTION
5	TOTAL DURATION OF SUNSHINE
6	BOREHOLE WATER LEVEL
7	SOIL TEST
8	PUMPING TEST
9	CALCULATION OF EVAPOTRANSPIRATION
10	KC VALUES RICE
11	KC VALUES FOR FIELD AND VEGETABLE CROPS
12	HYDRAULIC DESIGN OF IRRIGATION CANAL
13	HYDRAULIC DESIGN (PADDY FIELD)
14	" (BREEDING PROGRAM PLOT)
15	" (VARIETY COLLECTION PLOT)
16	PROBABLE RAINFALL
17	WORK CAPACITY
18	CONSTRUCTION SCHEDULE

Table 1 Monthly Mean Air Temp (Average)

	(°c)										
	Jan	Feb	Mar	Apr	May	Jun	Jul	Aug	Sep	Oct	Nov
1973	25.0	28.2	29.7	32.1	30.2	29.3	28.7	28.4	27.8	26.7	24.1
1974	23.4	25.6	28.0	28.8	28.5	28.2	28.2	27.7	27.4	26.8	25.1
1975	24.5	26.7	29.4	30.4	28.6	27.7	27.4	27.4	26.9	26.5	24.6
1976	21.1	25.9	27.8	29.9	27.9	28.4	28.3	28.1	27.8	27.2	24.4
1977	25.1	25.2	27.5	29.8	29.1	29.5	28.6	28.4	28.1	27.4	24.5
1978	25.7	26.7	30.2	30.6	29.3	28.7	28.1	27.6	27.6	26.2	24.6
1979	26.0	27.6	29.7	30.2	30.2	28.9	28.8	28.3	27.8	26.0	23.8
1980	24.1	26.7	29.6	31.7	31.4	29.9	29.1	28.8	28.0	26.8	25.8
1981	23.1	26.8	29.1	30.3	30.0	28.2	28.7	28.0	28.1	27.6	25.7
1982	23.2	28.0	29.6	29.4	29.9	28.4	28.3	27.6	27.5	27.3	26.9
1983	23.1	27.5	29.4	31.7	31.1	29.8	29.5	28.5	28.2	27.4	24.2
1984	23.7	27.2	28.7	30.6	29.9	28.5	28.7	29.2	28.1	26.8	25.8
1985	25.5	28.7	30.0	31.1	29.8	28.8	28.0	28.7	28.0	27.4	26.5
1986	22.9	27.1	28.6	30.7	29.4	29.0	28.3	28.8	28.6	27.7	25.9
1987	24.6	26.6	28.5	30.5	30.3	29.5	29.5	29.1	28.3	27.7	27.3
Mean	24.1	27.0	29.1	30.5	29.7	28.9	28.5	28.3	27.9	27.0	25.3

Table 2 Monthly Mean Humidity (Average)

	(%)											
	Jan	Feb	Mar	Apr	May	Jun	Jul	Aug	Sep	Oct	Nov	Dec
1973	66	64	66	62	69	76	74	74	77	79	77	66
1974	64	63	67	73	76	74	71	75	76	79	77	73
1975	76	68	64	63	72	71	70	74	79	78	79	71
1976	67	68	66	63	74	67	69	76	77	76	79	72
1977	70	68	68	68	72	70	73	72	76	76	72	67
1978	68	68	59	62	70	73	75	76	74	77	74	70
1979	67	64	61	64	66	69	67	69	75	71	68	67
1980	67	64	63	65	66	75	73	74	73	78	73	68
1981	65	62	61	65	68	72	69	70	73	71	79	67
1982	59	62	62	65	69	73	71	82	75	73	71	66
1983	63	63	60	63	68	73	75	78	79	83	79	73
1984	73	73	69	66	70	75	75	73	76	77	75	71
1985	69	67	66	65	76	77	78	79	79	80	80	71
1986	67	67	62	69	74	76	78	78	77	80	74	72
1987	67	69	68	69	74	71	68	72	78	80	83	74
Mean	67	66	64	66	71	73	72	75	76	77	76	70

Table 3

Monthly Mean Wind Velocity

(m/sec)

	Jan	Feb	Mar	Apr	May	Jun	Jul	Aug	Sep	Oct	Nov
1973	1	1	2	2	1	2	2	2	1	2	2
1974	2	2	2	2	2	3	3	2	1	1	3
1975	2	2	2	3	2	2	2	2	1	1	3
1976	2	2	2	2	2	3	2	2	2	2	3
1977	2	2	3	2	2	2	2	3	2	2	2
1978	2	2	3	2	2	2	2	2	2	2	2
1979	1	2	3	2	3	2	2	2	1	2	3
1980	1	2	2	2	2	1	2	2	2	1	2
1981	1	1	2	2	2	1	2	2	1	2	2
1982	1	2	2	2	2	1	2	2	1	1	1
1983	2	3	3	3	2	2	2	2	1	1	2
1984	1	2	2	2	2	2	1	2	1	1	2
1985	1	2	2	2	1	1	2	2	1	1	1
1986	1	1	2	1	2	1	1	1	1	1	1
1987	1	1	2	1	1	1	2	1	1	1	1
Mean	1	2	2	2	2	2	2	2	1	1	2

Table 4 AVERAGE MEAN MONTHLY RAINFALL DISTRIBUTION

	JAN	FEB	MAR	APR	MAY	JUN	JUL	AUG	SEP	OCT	NOV	DEC	TOTAL
1973	0	0	33.2	9.5	173.5	156.6	161.7	106.9	178.8	261.7	73.3	1.0	1,156.2
1974	0	0	30.9	173.8	43.1	122.6	172.8	119.4	322.3	320.9	48.2	1.1	1,355.1
1975	60.9	-	0.1	5.0	166.3	153.7	68.3	99.8	243.0	272.7	60.6	18.7	1,149.1
1976	0	64.0	2.5	14.5	199.8	66.8	76.4	237.7	235.6	154.8	88.8	0	1,140.9
1977	0	0	11.5	110.5	156.0	106.4	108.0	80.3	200.3	140.4	11.3	0.6	925.3
1978	9.8	26.7	0.5	101.1	208.1	165.0	266.0	40.2	271.1	87.6	6.1	0	1,132.2
1979	0	15.4	0	136.3	69.2	96.0	73.4	29.6	306.1	52.1	22.6	0	800.7
1980	0	1.8	2.2	0	63.8	207.7	70.3	147.4	157.7	342.7	16.4	0	1,010.0
1981	0	3.2	1.5	53.1	147.8	82.0	157.3	113.1	256.1	48.1	244.3	-	1,106.5
1982	0	0	14.9	114.3	125.5	117.9	80.4	80.3	213.2	170.3	8.5	5.1	930.4
1983	-	0.0	0.3	0.0	64.7	75.4	279.1	175.1	276.3	380.6	144.9	11.5	1,407.9
1984	-	8.7	19.2	20.9	117.6	40.9	70.2	46.6	120.2	107.3	8.7	0.1	560.4
1985	0.3	6.0	1.5	88.4	136.4	48.8	175.8	89.3	241.0	103.3	104.7	0.0	995.5
1986	0.0	0.0	5.0	40.3	141.4	117.9	151.9	179.8	288.6	301.5	36.4	14.0	1,276.8
1987	0.0	0.3	1.4	87.3	21.5	18.4	5.2	80.1	136.9	270.9	213.8	0.0	835.8
TOTAL	71.0	126.1	124.7	955.0	1834.7	1576.1	1916.8	1625.6	3447.2	3014.9	1088.6	52.1	15,832.8
MEAN													

Table 5

Total Duration of Sunshine

(hours)

	Jan	Feb	Mar	Apr	May	Jun	Jul	Aug	Sep	Oct	Nov	Dec	T
1973	288.7	261.4	224.1	270.9	227.6	167.8	139.2	138.2	144.4	208.0	184.2	276.0	253
1974	252.2	234.0	251.1	211.3	175.1	148.8	186.2	141.6	188.9	181.9	213.6	235.5	247
1975	160.2	230.7	238.7	241.0	177.1	110.8	188.1	93.0	127.0	178.9	238.7	238.9	227
1976	281.3	234.7	242.6	255.4	165.1	211.4	138.3	136.6	196.1	187.9	231.0	256.2	253
1977	237.9	222.0	224.5	261.9	231.9	217.3	128.0	146.6	143.0	240.1	251.4	269.2	257
1978	219.7	176.1	280.8	267.3	210.3	165.9	147.4	84.1	130.9	201.2	240.9	276.2	240
1979	265.4	231.9	284.1	238.7	227.8	139.7	197.9	119.5	143.7	260.7	278.9	271.2	268
1980	259.3	257.4	252.2	255.0	241.0	128.6	163.0	180.0	127.3	177.6	205.4	272.8	251
1981	262.6	209.8	278.9	244.2	214.0	94.0	138.0	126.0	142.0	191.0	142.0	233.0	227
1982	272.0	242.0	255.0	256.0	218.0	103.0	144.0	74.0	119.0	211.0	245.0	244.0	238
1983	258.0	249.0	255.0	243.0	240.0	189.0	208.0	156.0	173.0	154.0	185.0	239.0	254
1984	243.0	236.0	275.0	227.0	218.0	130.0	195.0	125.0	145.0	187.0	239.0	252.0	247
1985	250.0	240.0	270.0	230.0	204.0	80.0	126.0	127.0	124.0	166.0	215.0	285.0	231
1986	271.0	243.0	271.0	242.0	192.0	167.0	145.0	152.0	182.0	182.0	256.0	251.0	255
1987	266.0	244.0	262.0	269.0	254.0	172.0	191.0	186.0	152.0	199.0	163.0	250.0	260
Mean	252.5	234.1	257.7	232.5	213.1	148.4	162.3	132.4	149.2	195.1	219.3	256.7	246

Table.6 BOREHOLE WATER LEVEL

DATE	Point A	Point B
8/22	-1.75 (m)	-1.75 (m)
23	-1.71	-1.72
24	-1.71	-1.72
25	-1.69	-1.71
26	-1.69	-1.71
30	-1.68	-1.70
mean	-1.71	-1.72

Table.7 Soil Test

NAME	R E S U L T																															
1. SPECIFIC GRAVITY TEST	Specific Gravity (15°C) = 2.65																															
2. LIQUID LIMIT TEST PLASTIC LIMIT TEST	Liquid Limit Plastic Limit Plasticity Index	W _L = 10.74 % W _P = 4.22 % I _P = 6.52 %																														
3. GRADATION ANALYSIS	<table border="1"> <tr> <td data-bbox="756 1218 1043 1391">PROPORTION</td> <td data-bbox="756 987 1043 1218">4.76mm <</td> <td data-bbox="756 815 1043 987">0.0 %</td> <td data-bbox="756 418 1043 815">MAXIMUM DIAMETER</td> <td data-bbox="756 244 1043 418">4.76 mm</td> </tr> <tr> <td></td> <td data-bbox="810 987 991 1218">4.76~2.00 mm</td> <td data-bbox="810 815 991 987">0.094%</td> <td data-bbox="810 418 991 815">60% DIAMETER</td> <td data-bbox="810 244 991 418">0.12 mm</td> </tr> <tr> <td></td> <td data-bbox="865 987 965 1218">2.00~0.42 mm</td> <td data-bbox="865 815 965 987">5.44 %</td> <td data-bbox="865 418 965 815">30% DIAMETER</td> <td data-bbox="865 244 965 418">0.065 mm</td> </tr> <tr> <td></td> <td data-bbox="919 987 987 1218">0.42~0.074 mm</td> <td data-bbox="919 815 987 987">58.19 %</td> <td data-bbox="919 418 987 815">10% DIAMETER</td> <td data-bbox="919 244 987 418">0.015 mm</td> </tr> <tr> <td></td> <td data-bbox="957 987 991 1218">0.074 ~0.005mm</td> <td data-bbox="957 815 991 987">31.48 %</td> <td data-bbox="957 418 991 815">COEFFICIENT OF UNIFORMITY</td> <td data-bbox="957 244 991 418">4.33 mm</td> </tr> <tr> <td></td> <td data-bbox="1007 987 1043 1218">0.005mm ></td> <td data-bbox="1007 815 1043 987">4.8 %</td> <td data-bbox="1007 418 1043 815">COEFFICIENT OF CURVATURE</td> <td data-bbox="1007 244 1043 418">2.35 mm</td> </tr> </table>		PROPORTION	4.76mm <	0.0 %	MAXIMUM DIAMETER	4.76 mm		4.76~2.00 mm	0.094%	60% DIAMETER	0.12 mm		2.00~0.42 mm	5.44 %	30% DIAMETER	0.065 mm		0.42~0.074 mm	58.19 %	10% DIAMETER	0.015 mm		0.074 ~0.005mm	31.48 %	COEFFICIENT OF UNIFORMITY	4.33 mm		0.005mm >	4.8 %	COEFFICIENT OF CURVATURE	2.35 mm
PROPORTION	4.76mm <	0.0 %	MAXIMUM DIAMETER	4.76 mm																												
	4.76~2.00 mm	0.094%	60% DIAMETER	0.12 mm																												
	2.00~0.42 mm	5.44 %	30% DIAMETER	0.065 mm																												
	0.42~0.074 mm	58.19 %	10% DIAMETER	0.015 mm																												
	0.074 ~0.005mm	31.48 %	COEFFICIENT OF UNIFORMITY	4.33 mm																												
	0.005mm >	4.8 %	COEFFICIENT OF CURVATURE	2.35 mm																												
4. PERMEABILITY TEST	Mean Value of k ₁₅ = 4.1 × 10 ⁻⁵ cm/sec																															

Table. 8 PUMPING TEST (By Ground Water Division)

No.	DEPTH m	DIAMETER AND LENGTH m	SLEEVE PIPE POSITION m	GROUND WATER LEVEL m	PUMPING WATER m	WATER DROP m	POSSIBLE PUMPING WATER m ³ /sec
MD 107	129	0.2 92.0	55.5-58.5 66.0-69.0 87.0-90.0	7.1	0.553	35.1	0.379
ME 1	180	0.2 92.0	33.0-36.0 69.0-75.0 84.0-90.0	4.4	0.962	15.1	1.514

Table. 10

kc Values for Rice

	Planting	Harvest	First & Second Month	Mid-season	Last 4 weeks
<u>Humid Asia</u>	Jun-Jul	Nov-Dec			
Wet season (monsoon)		"			
light to mod. wind			1.1	1.05	.95
strong wind			1.15	1.1	1.0
dry season ^{1/}	Dec-Jan	mid-May			
light to mod. wind			1.1	1.25	1.0
strong wind			1.15	1.35	1.05

^{1/} Only when RHmin > 70%, kc values for wet season are to be used.

Table. 11

kc Values for Field and Vegetable Crops

	Humidity	RHmin > 70%		RHmin < 20%	
		0-5	5-8	0-5	5-8
Corn (sweet) (maize)	<u>Crop stage</u>				
	Mid-season	1.05	1.1	1.15	1.2
	at harvest or maturity	0.95	1.0	1.05	1.1
Tomato	mid-season	1.05	1.1	1.2	1.25
	at harvest or maturity	0.6	0.6	0.65	0.65
Sugarcane	planting to 0.25 full canopy	.55	.6	.4	.45
	0.25-0.5 full canopy	.8	.85	.75	.8
	0.5-0.75 full canopy	.9	.95	.95	1.0
	0.75 to full canopy	1.0	1.1	1.1	1.2
	peak use	1.05	1.15	1.25	1.3
	early senescence	.8	.85	.95	1.05
	ripening	.6	.65	.7	.75

HYDRAULIC DESIGN OF IRRIGATION CANAL

Table. 12

C A N A L	DESIGN WATER REQUIREMENT MAXIMUM WATER REQUIREMENT	CANAL SLOPE	CANAL TYPE	BASE WIDTH	WATER DEPTH	VELOCITY	FREEBOARD	SIDE WALL HEIGHT	REMARKS
Breeding Program Plot	61.0 (ℓ/s)	1/2,000	CONCRETE LINING (TRAPEZIUM)	0.20 m	0.30 m	0.41 m/s	0.12 m	0.45 m	
Variety Collection Plot	111.0	1/1,000	CONCRETE LINING (TRAPEZIUM)	0.40	0.27	0.62	0.14	0.45	Main canal
	37.0	1/500	CONCRETE LINING (TRAPEZIUM)	0.20	0.17	0.59	0.12	0.30	Lateral canal
Paddy Field	28.8	1/2,000	CONCRETE LINING (TRAPEZIUM)	0.25	0.19	0.34	0.12	0.40	
	91.8			0.25	0.34	0.46	0.05		

注) H > WATER REQUIREMENT HEIGHT

H > MAXIMUM WATER REQUIREMENT + 0.05

Table.13 HYDRAULIC DESIGN (Paddy Field)

VARIOUS HEAD LOSSES	AREA OF FLOW A_i (m ²)	HEAD LOSS COEFFICIENT		REMARKS
		f_i	$\frac{f_i}{A_i^2}$	
1				
2	INFLOW (ϕ 400)	0.126	0.500	31.25
3	FRICITION	"	$124.5 \times (0.014)^2 \times 4.80 / (0.40)^{4/3}$	24.81
4	OUTFLOW	"	1.000	62.50
5				
6	INFLOW (ϕ 400)	0.126	0.500	31.25
7	FRICITION	"	$124.5 \times (0.014)^2 \times 2.60 / (0.40)^{4/3}$	13.44
8	OUTFLOW	"	1.000	62.50
9				
10				Q=0.0918m ³ /s VARIOUS
11				HEAD LOSS H=0.10(m)
12				INLET DEPTH EL7.59
13				
14				
15				
16				
17				
18				
19				
20				

$$K = \frac{1}{\sqrt{\sum (\frac{f_i}{A_i^2})}} = \frac{1}{\sqrt{225.75}} = 0.067 \quad \therefore Q = K \sqrt{2gH} = 0.067 \sqrt{19.6H} = 0.297 \sqrt{H}$$

Table.14 HYDRAULIC DESIGN (Breeding Program Plot)

VARIOUS HEAD LOSSES	AREA OF FLOW A_i (m^2)	A_i^2	HEAD LOSS COEFFICIENT		REMARKS
			CALCULATION OF HEAD LOSS	f_i	
1					
2 INFLOW ($\phi 400$)	0.126	0.016		0.500	31.25
3 FRICTION	"	"	$124.5 \times (0.014)^2 \times 20.5 / (0.40)^{4/3}$	1.697	106.06
4 OUTFLOW	"	"		1.000	62.50
5					
6 INFLOW ($\phi 400$)	0.126	0.016		0.500	31.25
7 FRICTION	"	"	$124.5 \times (0.014)^2 \times 12.0 / (0.40)^{4/3}$	0.994	62.13
8 OUTFLOW	"	"		1.000	62.50
9					
10 INFLOW ($\phi 400$)	0.126	0.016		0.500	31.25
11 FRICTION	"	"	$124.5 \times (0.014)^2 \times 12.55 / (0.40)^{4/3}$	1.039	64.94
12 OUTFLOW	"	"		1.000	62.50
13					
14 INFLOW ($\phi 400$)	0.126	0.016		0.500	31.25
15 FRICTION	"	"	$124.5 \times (0.014)^2 \times 1.60 / (0.40)^{4/3}$	0.132	8.25
16 OUTFLOW	"	"		1.000	62.50
17					
18					Q-0.061 m^3/s VARIOUS
19					HEAD LOSS H-0.12(m)
20					INLET DEPTH EL9.77

$$K = \frac{1}{\sqrt{\sum (C_i / A_i^2)}} = \frac{1}{\sqrt{616.38}} = 0.040 \quad \therefore Q = K \sqrt{2EH} = 0.040 \sqrt{19.76H} = 0.177 \sqrt{H}$$

Table.1.5 HYDRAULIC DESIGN (Variety Collection Plot)

VARIOUS HEAD LOSSES	AREA OF FLOW A_i (m^2)	A_i^2	HEAD LOSS COEFFICIENT		$\frac{f_i}{A_i^2}$	REMARKS
			HEAD LOSS COEFFICIENT	f_i		
1	(m^2)					
2 INFLOW ($\phi 400$)	0.126	0.016		0.500	31.25	
3 FRICTION	"	"	$124.5 \times (0.014)^2 \times 20.00 / (0.40)^{4/3}$	1.656	108.50	
4 OUTFLOW	"	"		1.000	62.50	
5						
6						Q-0.111 m^3/s VARIOUS
7						HEAD LOSS H-0.12(m)
8						INLET DEPTH EL9.05
9						
10						
11						
12						
13						
14						
15						
16						
17						
18						
19						
20						

$$K = \frac{1}{\sqrt{\sum (f_i/A_i^2)}} = \frac{1}{\sqrt{197.25}} = 0.071 \quad \therefore Q = K \sqrt{2gH} = 0.071 \sqrt{19.6H} = 0.314 \sqrt{H}$$

Table 16 PROBABLE RAINFALL

PROBABLE YEAR	RAIN FALL
1 / 2	80 mm/day
1 / 5	98
1 / 10	110
1 / 20	120

Table. 17

WORK CAPACITY

WORK	CONS.	CALUCULATION	WORK CAPACITY
EXCAVATION BY MANPOWER	10 M	$1.0 \text{ m}^3 + 0.4 \text{ M/day} \times 10 \text{ M}$	25m ³ /day
EXCAVATION BY BULL-DOZER	1 U	_____	Top soil 259m ³ /day Others 302.4m ³ /day
EXCAVATION BY BACK-HOW SHOVEL	1 U	_____	183.4m ³ /day
COMPACTING BY MANPOWER	10 M	$10\text{m}^3 \div 2.8 \text{ M/day} \times 10 \text{ M}$	35m ³ /day
COMPACTING BY COMPACTOR	5 M	$10\text{m}^3 \div 1.6 \text{ M/day} \times 5 \text{ M}$	31.3m ³ /day
COMPACTING BY VIBRATION ROLLER	1 U	_____	137.1m ³ /day
SMOOTHING OF FACE	5 M	$10\text{m}^3 \div 0.2 \text{ M/day} \times 5 \text{ M}$	250m ³ /day
SPREADING	1 U	_____	Top soil 523.3m ³ /day Others 582.1m ³ /day
LINING CONCRETE	—	_____	1 SPAN = 6m/day
WOODEN FORM	—	_____	1 SPAN = 6m/day
CONCRETE PLACING	—	_____	1.5 m ³ /day
H A U L I N G	—	_____	201.6 m ³ /day

TABLE. 18 CONSTRUCTION SCHEDULE

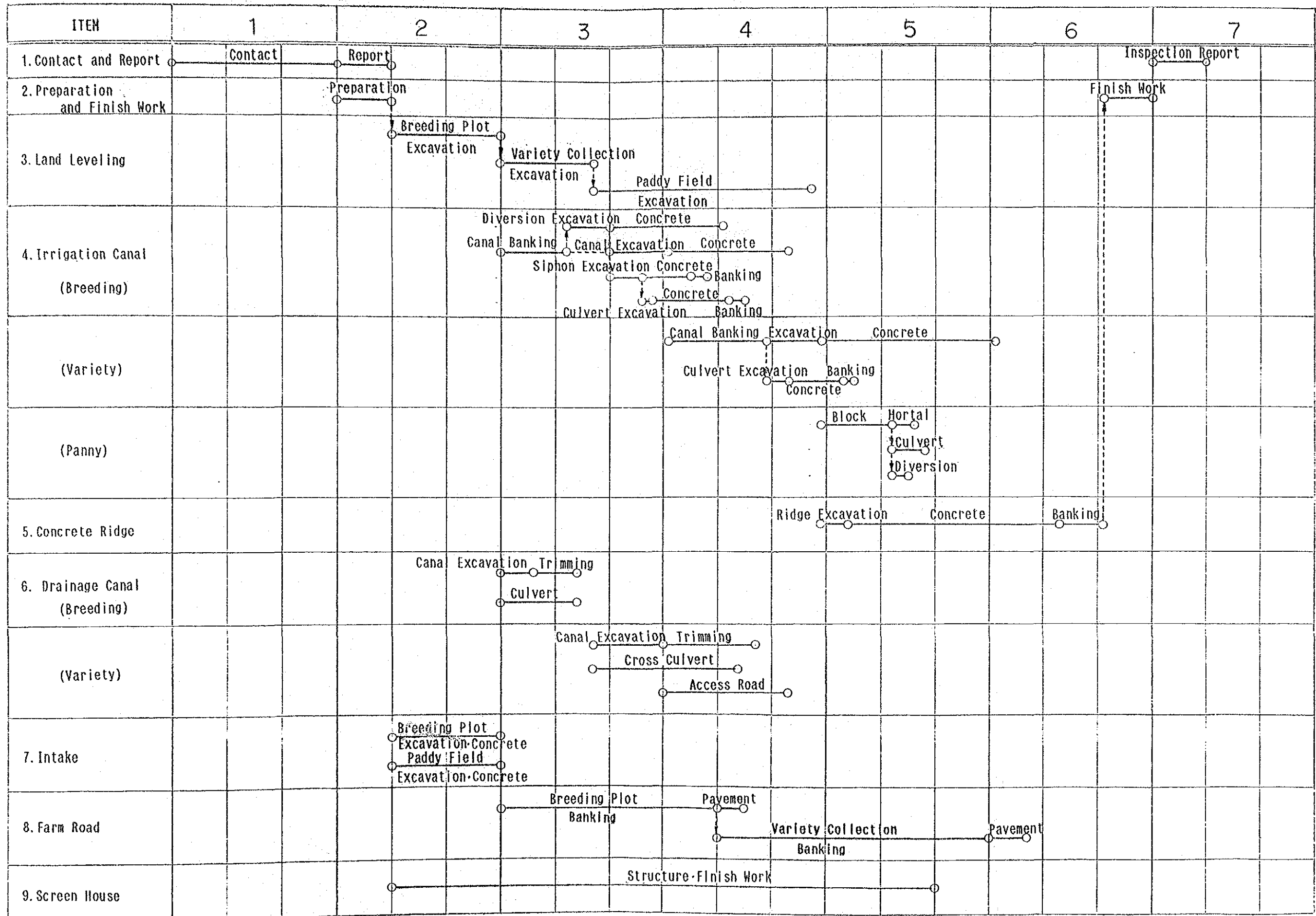

II. FIGURES LIST

No.	T I T L E
1	LOCATION MAP
2	LOCALITY MAP OF THE OUTCROPS
3	MONTHLY MEAN WIND VELOCITY
4	TOTAL DURATION OF SUNSHINE
5	MONTHLY MEAN AIR TEMP
6	MONTHLY MEAN HUMIDITY
7	AVERAGE MEAN MONTHLY RAINFALL DISTRIBUTION
8	MONTHLY MEAN EVAPORATION
9	LOCATION OF SAMPLING FOR THE WATER QUALITY AND SOIL TEST
1 0	WATER QUALITY CLASSIFICATION
1 1	IRRIGATION AND DRAINAGE CANAL NETWORKS
1 2	LOCATION OF RID CANAL
1 3	LOCATION OF FARM POND
1 4	CONSOLIDATION PROJECT AREA
1 5	WORKING EFFICIENCY AND LENGTH OF RUN OF EIELD LOTS
1 6	PLANE OF STUDY AREA
1 7	IRRIGATION PLANS
1 8	PROBABILITY ANALISIS
1 9	DRAINAGE PLANS
2 0	DRAINAGE CANAL STANDARD CROSS SECTION
2 1	FARN ROAD STANDARD CROSS SECTION

FIG. 1 LOCATION MAP

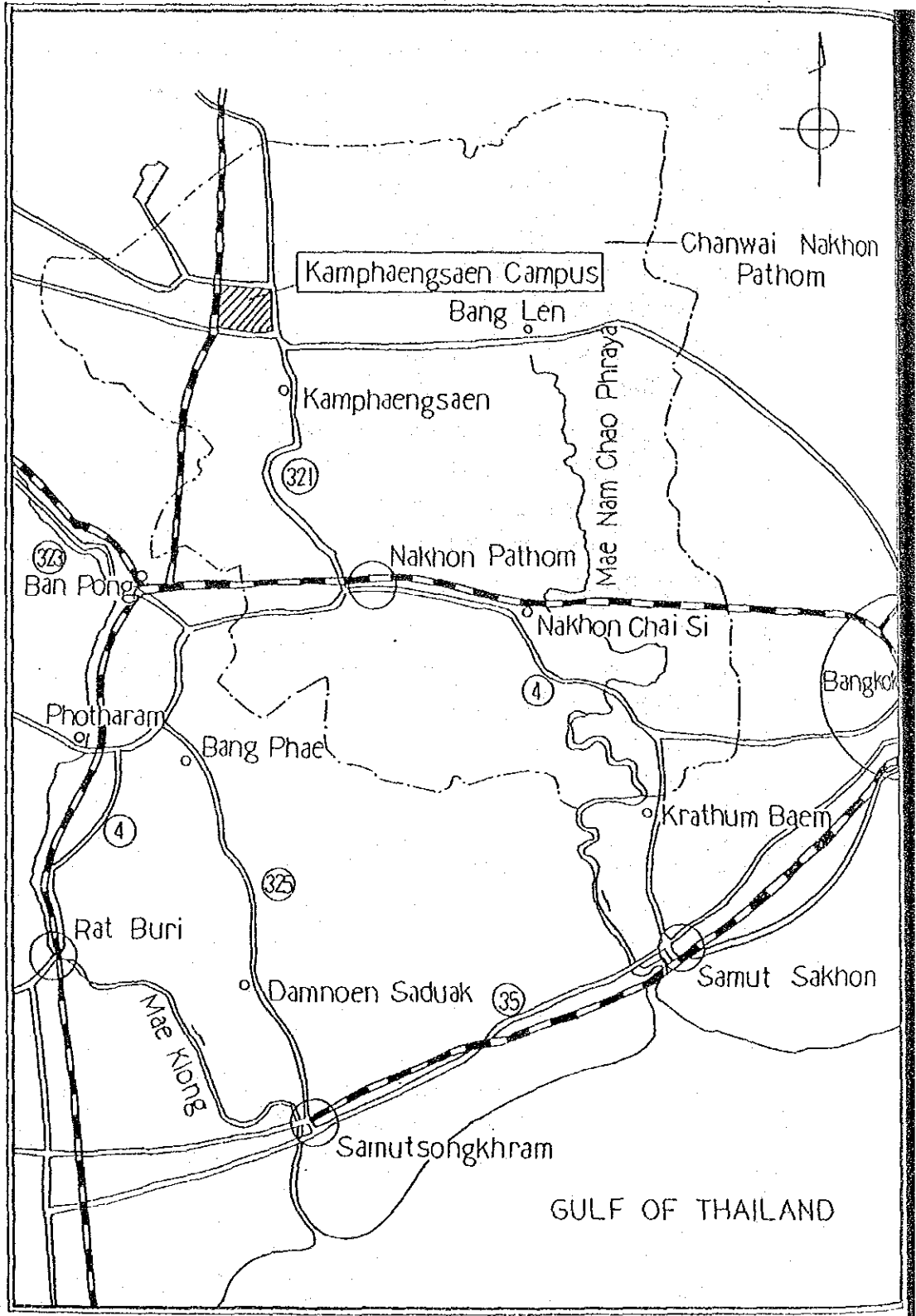
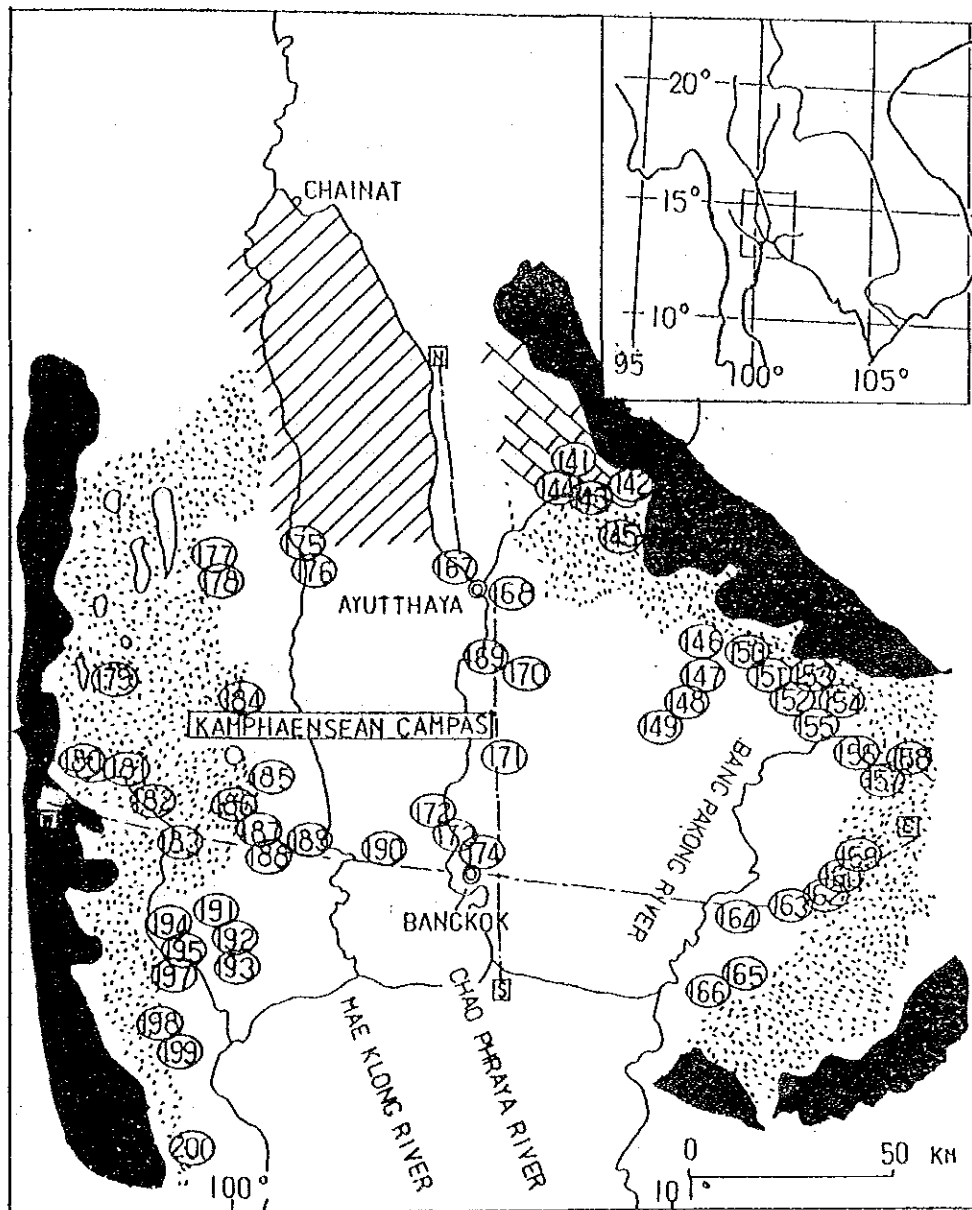

FIG. 2 LOCALITY MAP OF THE OUTCROPS



- RECENT DELTA
 - OLD DELTA
 - FAN COMPLEX AREA
 - CALCAREOUS AREA
 - PRE-QUATERNARY AREA
- N
S
- W
E
- CROSS-SECTIONS

FIG 3 MONTHLY MEAN WIND VELOCITY

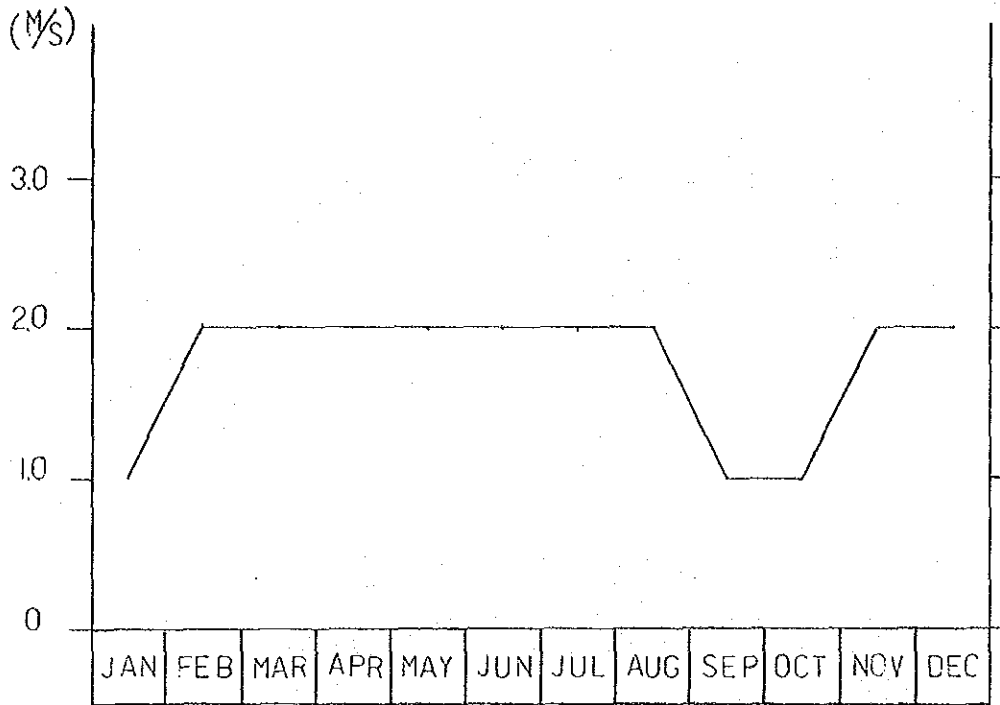

FIG 4 TOTAL DURATION OF SUNSHINE

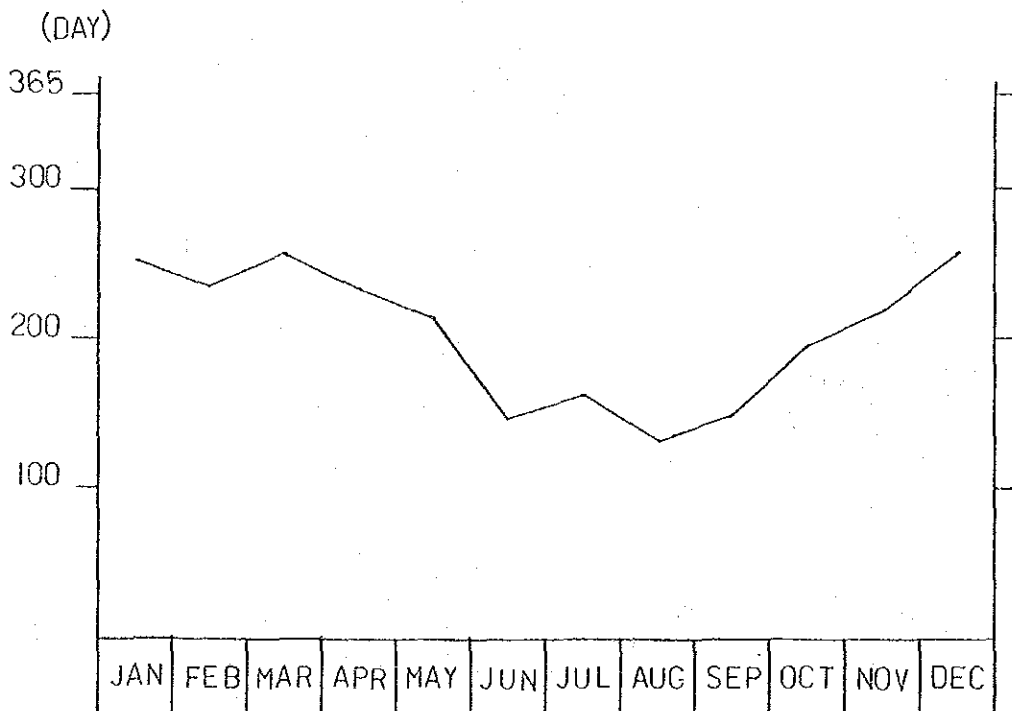

FIG. 5 MONTHLY MEAN AIR TEMP. (°C) (DATA: 1973-1987)

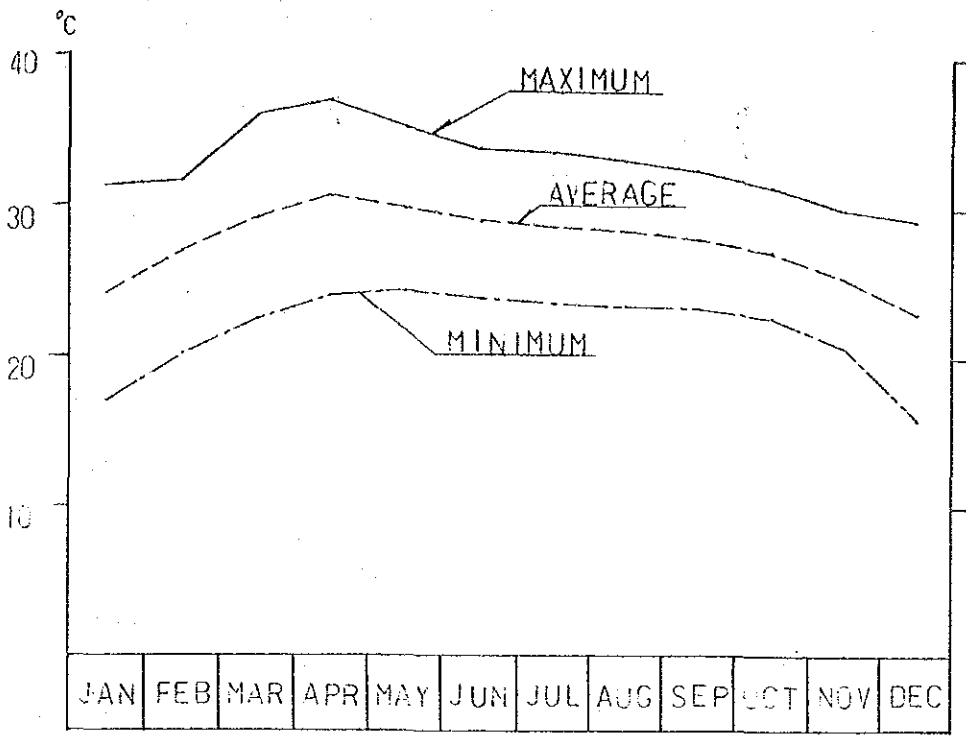

FIG. 6 MONTHLY MEAN HUMIDITY (DATA: 1973-1987)

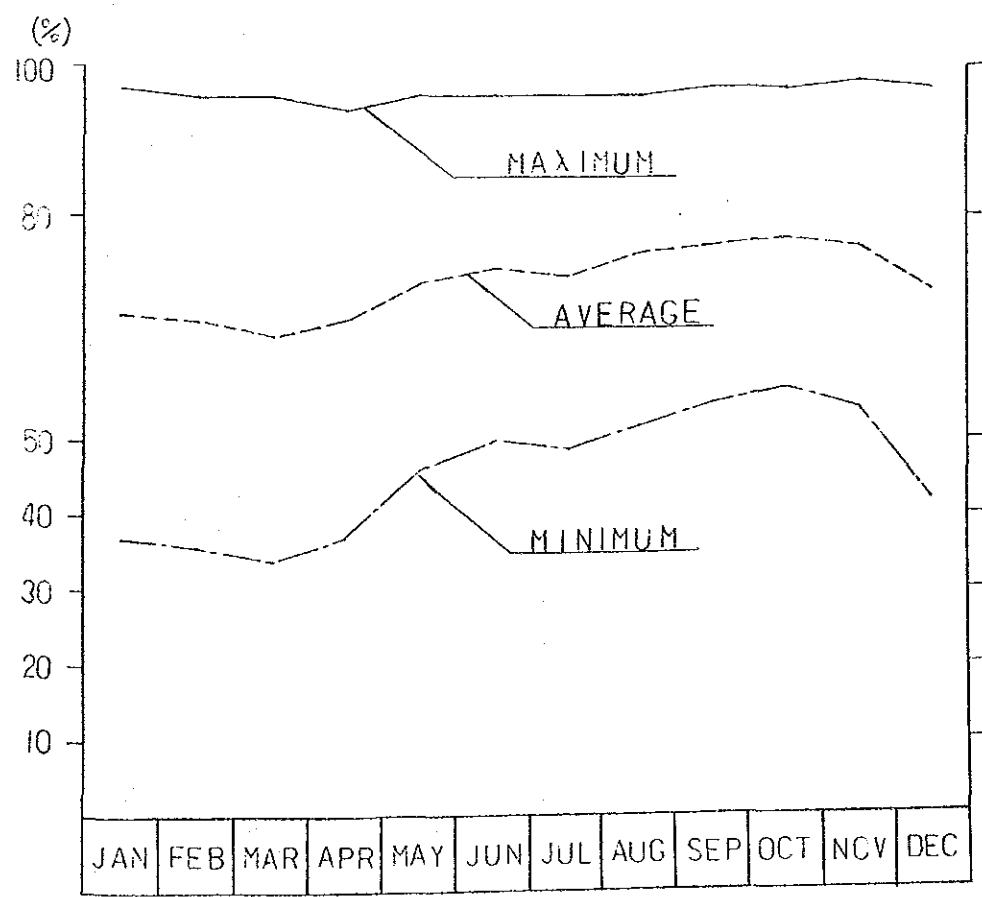

FIG 7 AVERAGE MEAN MONTHLY RAINFALL DISTRIBUTION

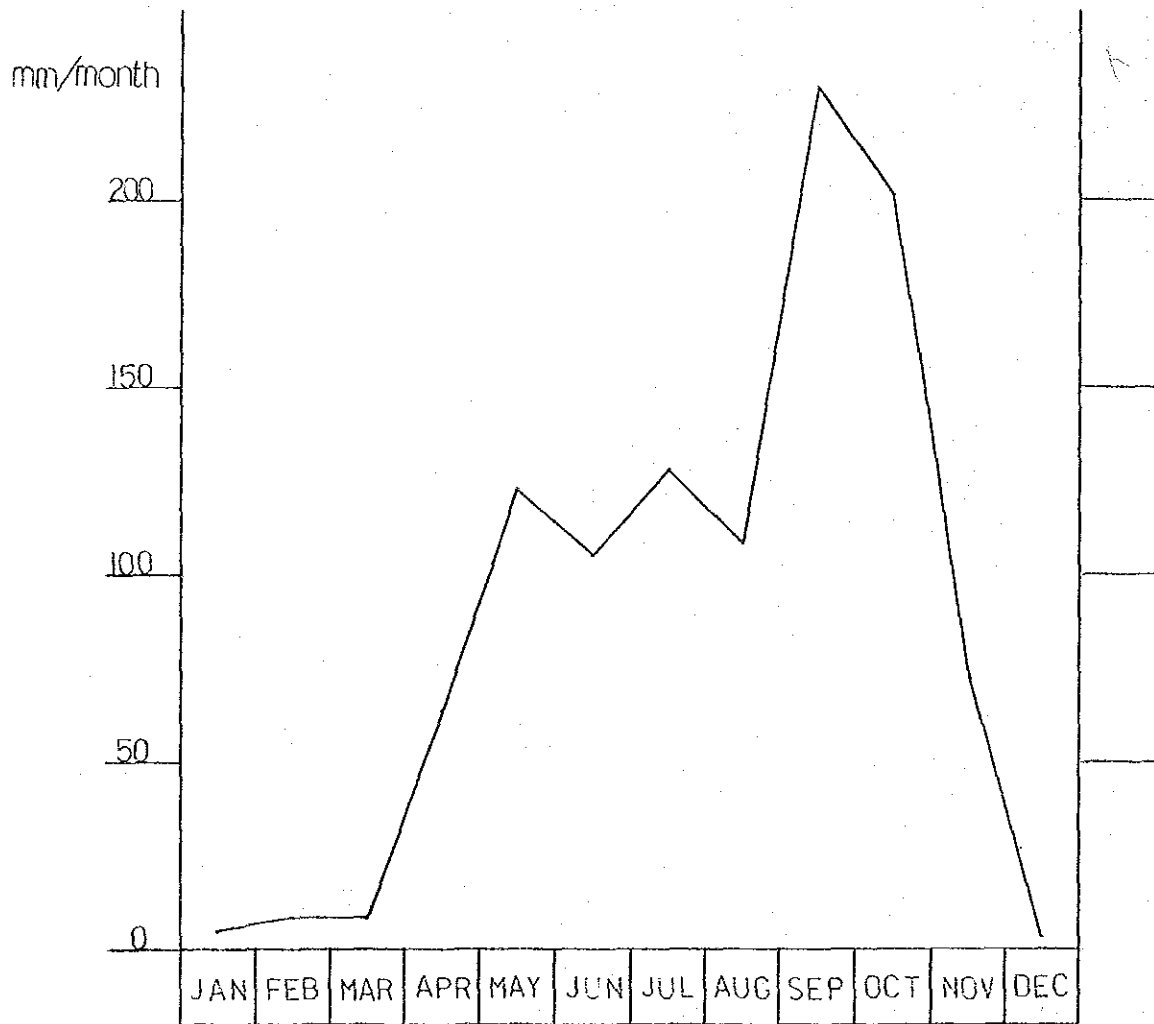
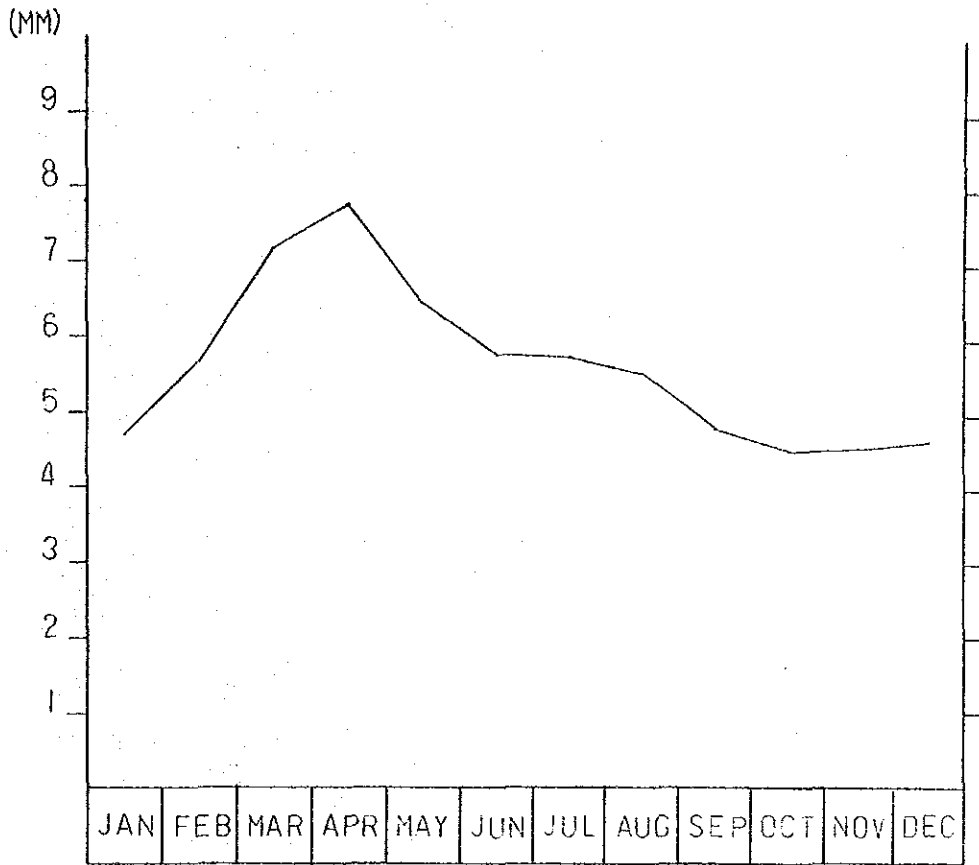

FIG 8 MONTHLY MEAN EVAPORATION



water quality test : NO.1~NO.8

soil test : A~C

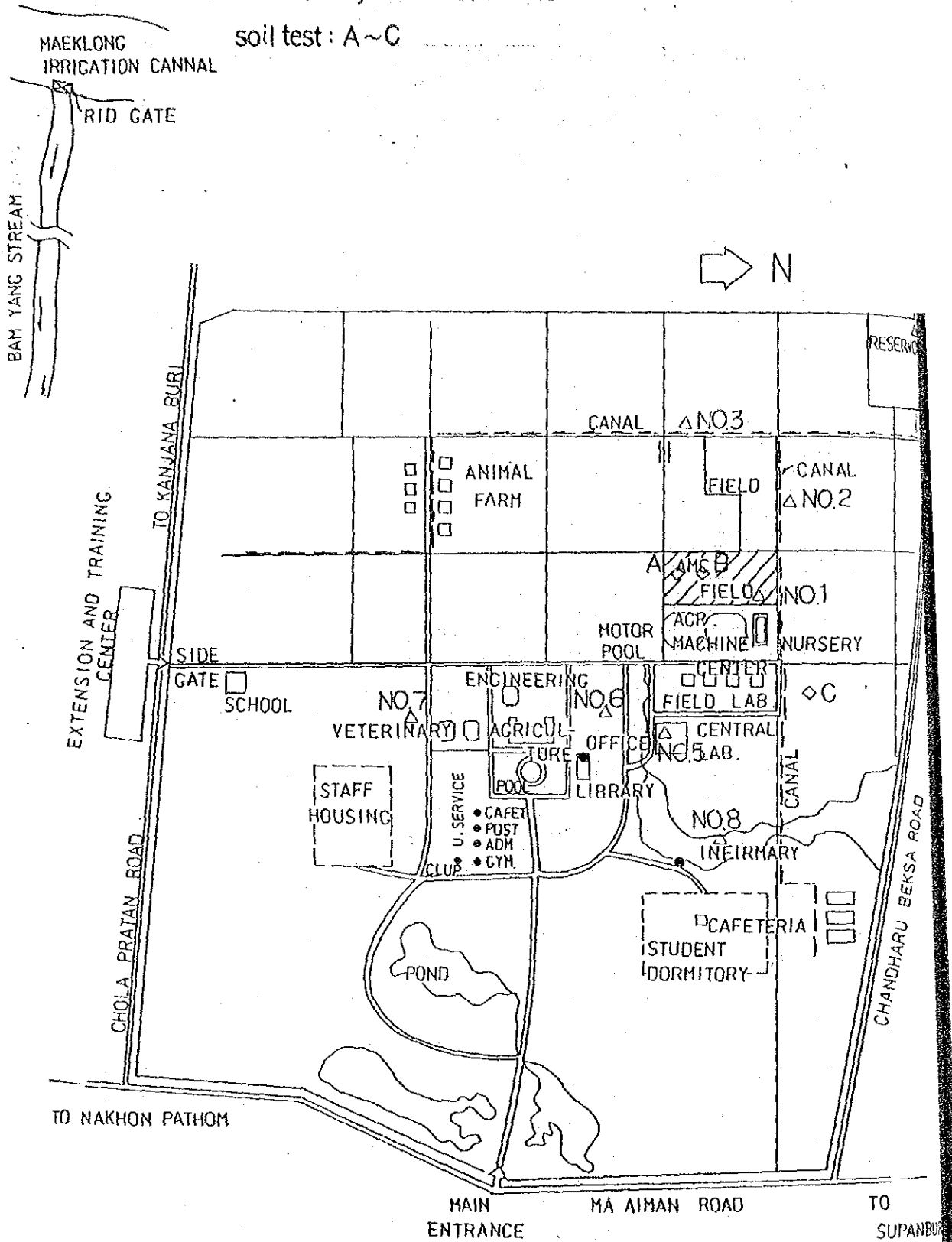
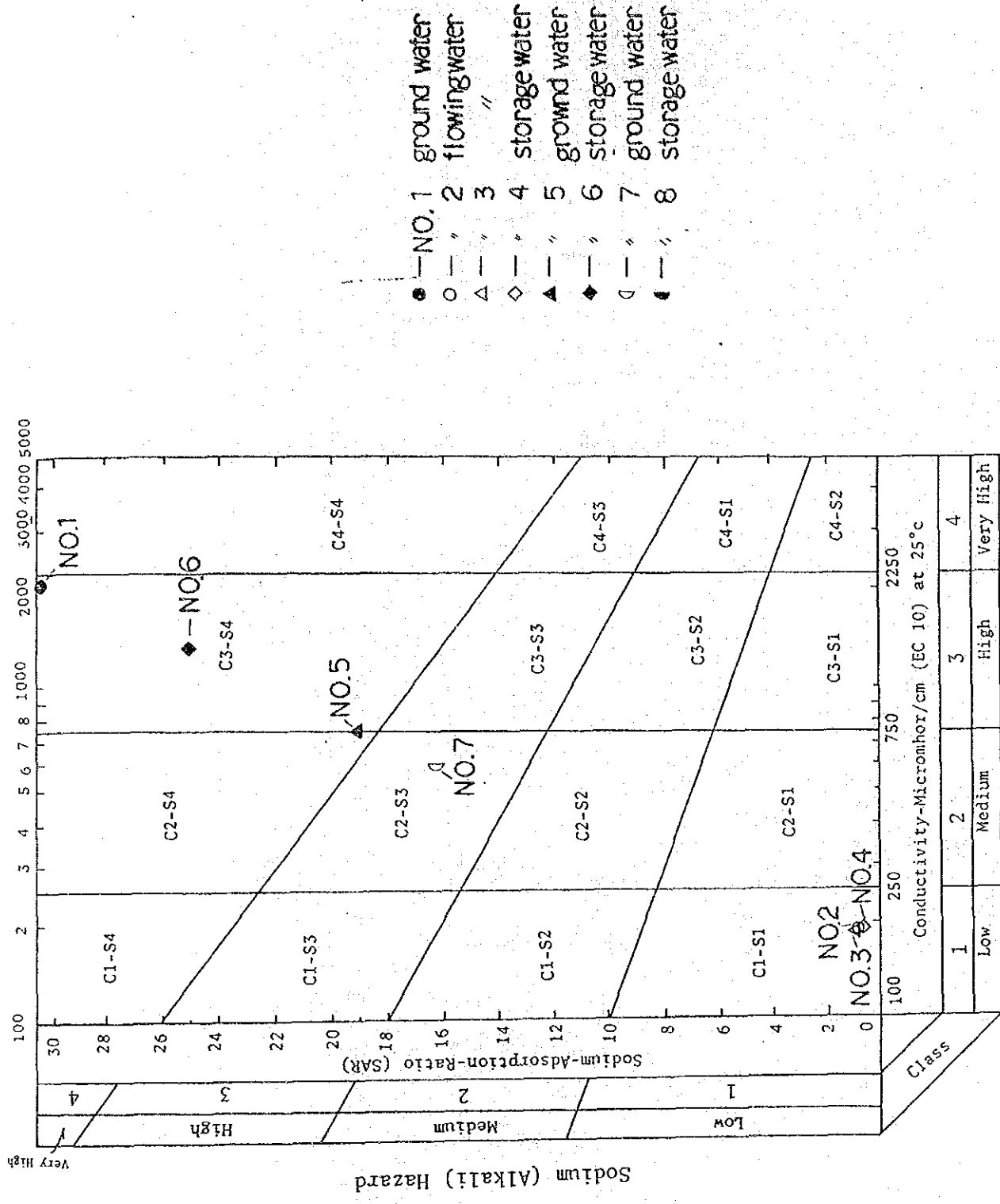

FIG. 9 LOCATION OF SAMPLING FOR THE WATERQUALITY AND SOIL

FIG. 10 WATER QUALITY CLASSIFICATION - NO. 8



Class	Conductivity-Micromhos/cm (EC 10) at 25°C			
	1 Low	2 Medium	3 High	4 Very High
S1	<p>Low sodium water can be used for irrigation in almost all soils with little danger of the development of harmful levels of exchangeable sodium. However, sodium sensitive crops such as stonefruit trees and avocados may accumulate injurious concentrations of sodium.</p>			
S2	<p>Medium water will present an appreciable sodium hazard in fine textured soils having high cation exchange capacity, especially under low leaching conditions unless gypsum is present in the soil. This water may be used on coarse textured or organic soils with good permeability.</p>			
S3	<p>High sodium water may produce harmful levels of exchangeable sodium in most soils, and will require special soils management; good drainage, high leaching, and organic matter conditions. Gypsiferous soils may not develop harmful levels of exchangeable sodium from such water. Chemical amendments may be required for replacement of exchangeable sodium, except that amendments may not be feasible in the case of water of very high salinity.</p>			
S4	<p>Very high sodium water is generally unsatisfactory for irrigation purposes, except at low and perhaps medium salinity where the solution of calcium from the soil or used of gypsum or other amendments may make the use of these waters feasible.</p>			
C1	<p>Low salinity water can be used for irrigation with most crops on most soils with little likelihood that soil salinity will develop. Some leaching is required but this occurs under normal irrigation practices, except in soils of extremely low permeability.</p>			
C2	<p>Medium salinity water can be used if a moderate amount of leaching occurs. Plants with moderate salt tolerance can be grown in most cases without special practices for salinity control.</p>			
C3	<p>High salinity water cannot be used on soils with restricted drainage, even with adequate drainage. Special treatment for salinity control may be required, and plants with good salt tolerance should be selected.</p>			
C4	<p>Very high salinity water is not suitable for irrigation under ordinary conditions, but may be used occasionally under very special circumstances. The soils must be permeable, drainage condition must be adequate, irrigation water must be applied in excess to provide considerable leaching and very salt-tolerance crops should be selected.</p>			

Fig.11 Irrigation And Drainage Canal Networks

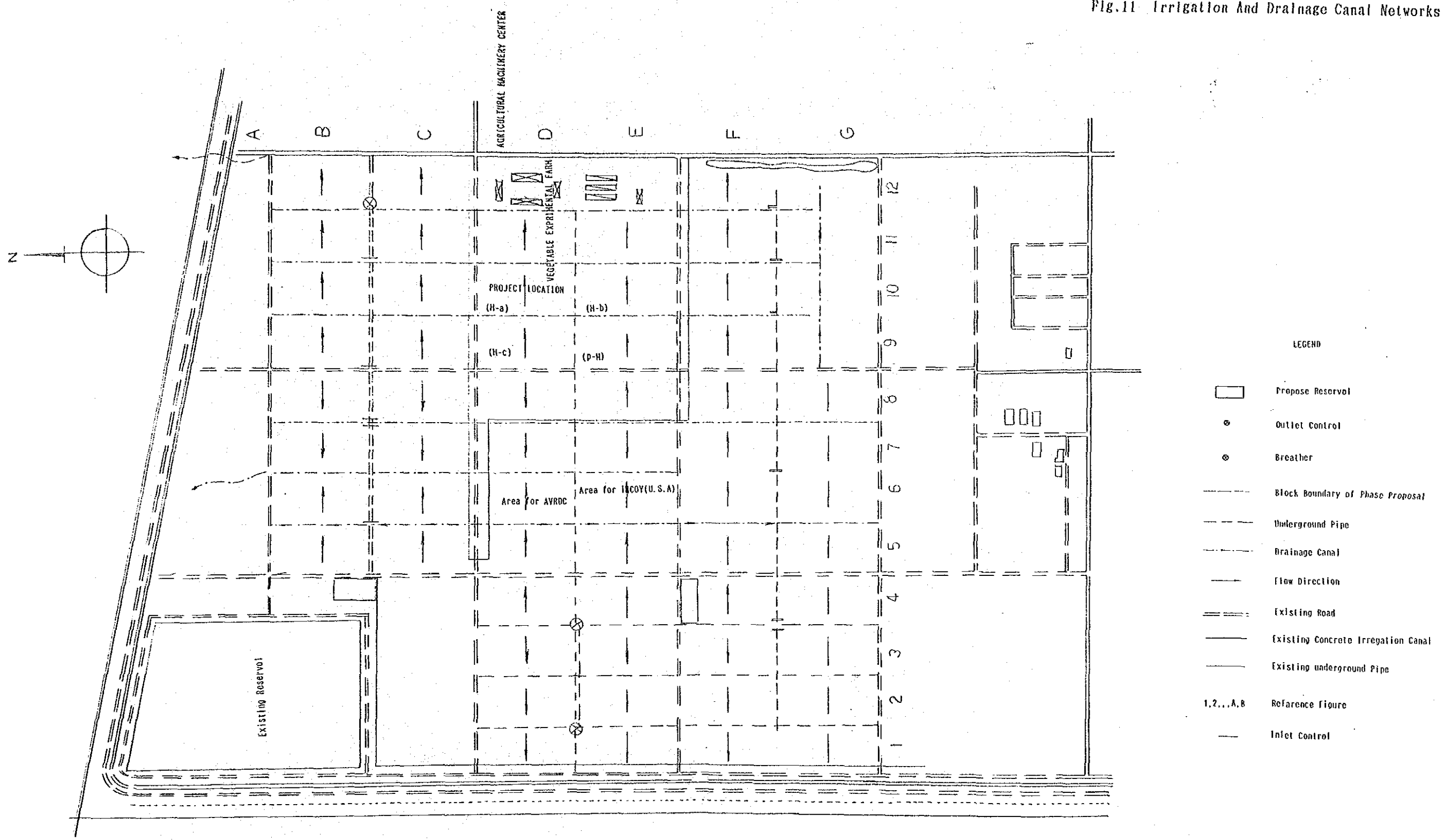

- LEGEND
- Propose Reserrol
 - Outlet Control
 - Breather
 - Block Boundary of Phase Proposal
 - Underground Pipe
 - Drainage Canal
 - flow Direction
 - Existing Road
 - Existing Concrete Irrigation Canal
 - Existing underground Pipe
 - 1,2...A,B Reference figure
 - Inlet Control

