

PART 7 ASPHALT PAVEMENT

7-01 SCOPE

In accordance with the specifications contained in this Part, and as shown on the drawings or as otherwise directed, the Contractor shall furnish all plant, labor, equipment and materials, and perform all operations in connection with construction of the asphalt pavement.

7-02 BASE COURSE

(a) Sub-base Course

Sub-base material shall consist of a natural or artificial mixture of hard, durable particles of coarse aggregate and soil binder. The material shall be free from soft or decomposed particles and excess clay, and shall be uniformly graded so that it can be compacted into a hard dense mass. Sub-base course aggregates shall conform to the following gradings.

Nominal Size (mm)	Percent Passing by Weight
40	90 - 100
20	60 - 85
5	45 - 65
2	30 - 50
0.5	10 - 25
0.074	5 - 15

Sub-base materials shall be placed and compacted in layers. Each layer shall be compacted to not less than 95% maximum dry density or such other percentage as may be determined by the Engineer as a result of tests. In addition the corrected CBR of the sub-base shall not be less than 20% as determined by JIS A-1211. The water content at the time of compaction shall be the optimum water content as determined by the above test or as directed by the Engineer. The finished surface shall not deviate more than 3 cm from the designated elevation, and the completed thickness of the sub-base course shall be within plus or minus 10% of the designated thickness.

(b) Base Course

Base course material shall consist of mixtures of gravel and crushed gravel and/or rock fragments of uniform specific gravity with silt and clay conforming to the following requirements, or of stone for hand pitched bases hereinafter specified.

Nominal Size (mm)	Percent Passing by Weight
40	100
20	60 - 100
10	50 - 90
5	35 - 75
2	25 - 60
0.5	15 - 30
0.2	6 - 20
0.074	3 - 8

Stone for hand pitched bases shall be of selected stones, roughly with prismatic shape having one dimension of at least 100 mm. Smaller stones will be necessary to fill the interstices between the larger stones.

The Contractor may use either of the above crushed stone bases or hand packed stone basis as directed by the Engineer.

Compaction and finishing works shall conform to the provision in Clause 7-02 (a) except for the corrected CBR of the base being not less than 60% as determined by JIS A-1211.

Prior to the placing of the base course, the Contractor shall furnish his detailed schedule, method and equipment to be used for bituminous surfacing works for the Engineer's approval.

#### 7-03 ASPHALT

##### (a) Bituminous Prime Coat

Prior to the placing of the bituminous material, the finished surface of the base course shall be completed in accordance with the provisions specified in Clause 7-02 (b). Immediately after completion of rolling, all loose dirt and other objectionable material shall be removed from the surface of the base course and the surface shall be cleaned. The surface shall be sprayed with the bituminous materials for the prime coat, which shall conform to medium curing cutback asphalt (MC-30, AASHO M82 or equivalent) or straight run asphalt of penetration grade of 80-100, and shall be approved by the Engineer.

In general the bituminous material shall be applied at a rate of 1.25 to 1.75 l/m<sup>2</sup> as directed by the Engineer. The distributor shall be so designed, equipped, maintained, and operated that bituminous material may be applied uniformly on the road surface at an even temperature.

Traffic shall not be permitted on the prime coated surface until the bituminous material has penetrated and dried and in the opinion of the Engineer, will not pick up under traffic, provided that if it becomes necessary to permit traffic prior to that time, but in no

case sooner than 12 hours after the application of bituminous material, 'blotter' material shall be applied as directed by the Engineer and traffic shall be permitted to use the road so treated.

(b) Aggregates

Aggregates for the various designations of surface treatment shall be crushed gravel or crushed stone, and shall meet the requirement for gradings.

Crushed gravel, crushed stone, or crushed slag shall consist of clean, tough, durable fragments free from dirt or other objectionable matter.

(c) Bituminous Materials

Bituminous materials shall be of the type and grade as directed by the Engineer, and shall conform to the requirements of the straight run asphalt having a penetration grade of 80-100, or as directed by the Engineer.

(d) Construction

The Contractor shall maintain the prime coated surface for a minimum of five days before covering it with the surfacing or next course, unless a shorter period is approved by the Engineer. Prior to application of the surfacing or next course, any surface breaks shall be patched and all excessive 'blotter' material, dirt, and other objectionable materials shall be removed by sweeping.

Prior to placing the first layer of surface treatment, loose dirt and other objectionable material shall be removed from the existing surface. If so directed by the Engineer, the surface shall be cleaned with a broom or blower upon the Engineer's approval.

Bituminous surface treatment shall be applied using quantities as specified on the Drawings, or as directed by the Engineer. Each spreading of aggregate shall immediately follow application of bituminous material, except where the first spreading is required to be placed directly on the previously bituminized surface.

Bituminous material shall be so applied that uniform distribution is obtained at all points. Application temperature shall be within the range of 140°C to 160°C, or as directed by the Engineer.

Spreading and shaping of each layer of aggregate for all designations of surface treatment shall be done with the approved aggregate spreading equipment.

Following spreading and smoothing, each layer of aggregate shall be rolled as directed. The final layer of treatment shall be alternately broom dragged and rolled thoroughly until the surface is fully compacted and bonded to full width.

Payment for asphalt pavement shall be made at the unit prices per square meter of the asphalted area. The unit prices shall be deemed to cover the costs of furnishing all labor, materials and equipment necessary to complete the asphalt pavement work, and of coating, mixing asphalt with aggregate, hauling placing and compacting the placed layer, and also the costs of other works connected therewith. The cost for construction of the base course in asphalt pavement of road shall be included in the unit price.

## PART 8 STONE MASONRY WORK

### 8-01 SCOPE

In accordance with specifications contained in this Part, and as shown on the drawings or as otherwise directed, the Contractor shall furnish all plant, labor, equipment and materials, and perform all operations in connection with the construction of stone masonry.

### 8-02 MATERIAL

#### (a) General

Samples of stone proposed for use as provided herein shall be submitted to the Engineer for approval prior to delivery of any such material to the site of work. Unless otherwise specified, all samples shall be obtained by the Contractor and delivered at his expense to a point designated by the Engineer at least 20 days in advance of the time when the placing of the material is expected to begin.

#### (2) Sand for Mortar

Sand for mortar shall conform to the requirements for PART 9 relative to fine aggregate for concrete.

### 8-03 FOUNDATION PREPARATION

Areas on which stone work is to be done shall be prepared in accordance with the requirements of PART 4. Where such areas are excavated below the designed line for foundation, they shall be brought to grade by filling with gravel or other materials approved by the Engineer and well compacted, and no additional payment will be made for foundation preparation and any materials thus required.

In the same manner, when such areas are above the designed line for the foundation, the said areas shall be brought to grade and the foundation similarly prepared without additional payment.

### 8-04 STONE MASONRY

#### (a) General

Stone masonry shall be placed at the locations indicated on the drawings or otherwise directed. Mortar, sand and stone shall conform to the applicable requirements of clause 8-02 as to applicable requirements of PART 9. The stone shall be kept free from dirt, oil, or any other injurious material which may prevent proper adhesion of the mortar. Individual stones shall have a thickness of not less than 10 centimeters.

#### (2) Construction

Mortar shall be one (1) part cement and three (3) parts sand in volume unless otherwise provided. All shaping or dressing of stone shall be done before the stone is laid, and so dressing or hammering which will loosen the stone will be permitted after it is placed. Each stone shall be cleaned and moistened with water before being

set. All stones shall be well bedded in freshly-made mortar. After completion, if any stone is moved or the joint broken, the stone shall be removed, the mortar shall be thoroughly cleaned from the bed and joints, and the stone reset in fresh mortar.

8-05 MEASUREMENT FOR PAYMENT

Measurement for payment for stone masonry will be based on the number of cubic meters acceptably placed as computed from the neat lines and grades indicated on the drawings or as directed in the field.

## PART 9 CONCRETE WORK

### 9-01 Scope

In accordance with the specifications contained herein and as shown on the detail drawings or otherwise directed, the Contractor shall:

- (a) Furnish all materials, and manufacture, transport, place, finish, protect and cure concrete;
- (b) Furnish, construct, erect and dismantle forms;
- (c) Construct expansion and contraction joints and furnish and place waterstops, joint fillers, and dealing compound, if required; and,
- (d) Prepare, clean, cut, bend and place steel reinforcement.

### 9-02 CEMENT

#### (a) General

Cement for mortar and concrete work shall be Portland Cement which conforms to the requirements of the Standard Specifications for Portland Cement (A.S.T.M. Designated C150-69).

#### (b) Storage

Cement shall be stored in a dry, weather tight and properly ventilated warehouse with adequate provisions for the prevention of absorption of moisture. All storage facilities shall be subject to approval and shall be such as to permit easy access for inspection and identification. Cement which has been stored for more than one month or which is suspected of being damp shall not be used unless otherwise approved by the Engineer.

### 9-03 FINE AGGREGATE

#### (a) Composition

Fine aggregate shall be natural sand not including organic matter and other foreign substances.

#### (b) Quality

Fine aggregate shall consist of hard, tough, durable, uncoated particles. The shape of the particles shall be generally rounded or cubical and reasonably free from flat or elongated pieces. The fine aggregate shall conform to the following specific requirements:

1. Grading - Fine aggregate shall be well graded from fine to coarse and the gradation shall conform to the following requirements as delivered to the mixtures:

Sieve Designation U.S. Std. Square Mesh	Cumulative Percentage by Weight Passing
No. 4	95 - 100
No. 16	60 - 75
No. 100	2 - 10

In addition to the grading limits shown above, the best modulus shall be in the range from 2.30 to 3.0.

(c) Storage

Fine aggregate shall be stored in such a manner as to avoid the inclusion of any foreign material in the concrete. Sufficient live storage shall be maintained at all times to permit continuous placement of concrete at the rate specified.

9-04 COARSE AGGREGATE

(a) Composition

Coarse aggregate shall consist of gravel, crushed gravel or rock, or a combination of gravel and crushed gravel or rock.

(b) Quality and Grading

1. Quality - Coarse aggregate shall consist of hard, tough, durable, clean and uncoated particles. All foreign materials and dust shall be removed by adequate processing. The particle shape of the smallest size of crushed coarse aggregate shall be generally rounded or cubical, and the coarse aggregate shall be reasonably free from flat and elongated particles in all sizes.
2. Grading - The coarse aggregate shall be well graded from fine to coarse. The grading of the aggregate as delivered to the mixer shall be as follows:

Sieve Designation U.S. Std. Sq. Mesh	Per Cent by Wt. Passing Individual Sieves 3/4" Max.
1"	100
3/4"	90 - 100
3/8"	20 - 55

3. Size - Unless otherwise directed, the maximum sizes of coarse aggregate to be used in the various parts of the work shall be 3/4 inch.
4. Storage - Storage of coarse aggregates shall be as that specified in paragraph 8-03 (c) for fine aggregates.



9-05 AGGREGATE SAMPLES

Samples of the aggregate shall be furnished at a point designated by the Engineer for his approval at least ten (10) days in advance of the time when the placing of concrete is expected to begin.

9-06 WATER

Water used in mixing concrete shall be fresh, clean and free from injurious amount of oil, acid, alkali, salts, or organic matter.

9-07 PROPORTIONING OF CONCRETE

- (a) The Contractor shall design the mix proportion for every class of concrete placing for the approval of the Engineer. The Contractor shall carry out the mix test in case being requested by the Engineer. The test is to be made at the expense of the Contractor.
- (b) The compressive strength of the age of 28 days shall be as follows for the desirable mix proportion indicated.

Class	Minimum 28 days Compressive Strength	Mixing proportion by volume cement : fine aggregates : coarse aggregates
A (Reinforced Concrete)	160 kg/cm <sup>2</sup>	1 : 3 : 6
B (Plain Concrete)	160 kg/cm <sup>2</sup>	1 : 3 : 6
C (Concrete Layer)	135 kg/cm <sup>2</sup>	1 : 4 : 8

Other proportions for mixed design if necessary may be indicated by the Engineer at the site of work.

9-08 MIXING

(a) Equipment

Concrete shall be mixed by portable concrete mixer unless otherwise approved by the Engineer.

(b) Measurement

The measurement of every ingredient of concrete shall be made by weight. Nevertheless, measurement by volume may be admitted subject to the approval of the Engineer.

(c) Mixing Time and Method

The mixing time of concrete shall be more than two (2) minutes and less than five minutes. Over mixing, requiring the introduction of additional water to preserve the required consistency, will not be permitted. The mixer shall be completely emptied before receiving the materials for the succeeding batch and shall be kept clean and washed out after stopping work at the end of each shift.

On commencing work, the first batch shall contain sufficient excess of cement, sand and water to coat the inside of the drum to avoid a reduction in the required mortar content of the mix.

9-09 CONVEYING

(a) General

Concrete shall be conveyed from mixer to forms, as rapidly as practicable, by methods which will prevent segregation or loss of ingredients. There shall be no vertical drop greater than 1.5 meters except where suitable equipment is provided to prevent segregation and where specifically authorized. Belt conveyors, chutes or other similar equipment in which the concrete is delivered to the structure in a thin, continuously exposed flow, will not be permitted except for very limited or isolated sections of the work. Such equipment shall be arranged to prevent objectionable segregation.

9-10 PLACING

(a) Approval

Approval of the Engineer shall be obtained before starting any concrete pour.

(b) General

Concrete shall be worked into the corners and angles of the forms and around all reinforcement and embedded items without permitting the material to segregate. Not more than three (3) cubic meters shall be deposited in one pile for compaction. Free water shall be collected in depressions away from the forms and removed by bailing prior to placement of additional concrete. All concrete placing equipment and methods shall be subject to approval.

(c) Cooling of Aggregates

The aggregate shall be cooled by wetting if it is drier than the condition known as saturated, surface dry.

(d) Concrete on Earth Foundation

All concrete shall be placed upon clean, damp surfaces free from standing or running water. Prior to placing concrete, the earth foundation shall be satisfactorily compacted in accordance with approved methods.

(e) Concrete on Other Concrete

The surface upon or against which concrete is to be placed shall be clean, free from oil, standing or running water, mud, rock, objectionable coatings, debris, and loose, semi-detached or unsound fragments. To insure a firm and tight bond between fresh concrete and other concrete, concrete surfaces, where necessary shall be chipped or roughened as directed by the Engineer. All surfaces shall be wetted thoroughly to keep them in a completely moist condition before placing concrete. All approximately horizontal surfaces shall be covered with a layer of mortar of the same-sand ratio as used in the concrete mix before the concrete is placed.

(f) Consolidation of Concrete

Concrete shall be placed and consolidated with the aid of mechanical vibrating equipment or of hand-spading and tamping. In no case shall vibrators be used to transport concrete inside the forms. In placing concrete through reinforcement, care shall be taken that no segregation of the coarse aggregate occurs.

9-11 FORMS

(a) General

Forms shall be used, wherever necessary, to confine the concrete and shape it to the required lines, or insure against contamination of the concrete. Forms shall have sufficient strength to withstand the pressure resulting from placement and vibration of the concrete, and shall be maintained rigidly in correct position. Forms shall be sufficiently tight to prevent loss of mortar from the concrete. Forms for exposed surfaces against which backfill is not to be placed shall be lined with a form grade plywood or sheet steel.

(b) Cleaning and Oiling of Forms

At the time concrete is placed in the forms, the surfaces of the forms shall be free from incrustations of mortar, grout, or other foreign material that would contaminate the concrete or interfere with the fulfillment of the Specifications' requirements relative to the finish of formed surfaces. Before concrete is placed, the surfaces of the forms shall be oiled with a commercial form oil that will effectively prevent sticking and will not stain the concrete surfaces.

(c) Removal of Forms

Forms shall be removed as soon as practicable in order to avoid delay in curing and to make possible the earliest practicable repair of surface imperfections, but in no case shall they be removed before approval. Any needed repair or treatment shall be performed at once, and shall be followed immediately by the specified curing. Forms shall be removed with care so as to avoid injury to the concrete, and any concrete so damaged shall be repaired.

9-12 CURING AND PROTECTION

(a) General

All concrete shall be moist cured for a period of not less than seven (7) consecutive days by an approved method or combination of methods applicable to local conditions, except that the curing period may be reduced to three days for concrete made with high-early-strength cement. The Contractor shall have all equipment needed for adequate curing and protection of the concrete on hand and ready to install before actual concrete placement begins.

(b) Water Curing

Concrete shall be kept wet by covering with an approved, water-saturated material or by a system of perforated pipes or mechanical sprinklers or by any other approved method which will keep all surfaces continuously (not periodically) wet. Water for curing shall

be generally clean and free from any element which might cause objectionable staining or discoloration of the concrete.

#### 9-13 REPAIR OF CONCRETE

Repair of imperfections in formed concrete shall be completed within twenty four (24) hours after removal of forms at no additional cost to JICA. Fins shall be neatly removed from exposed surfaces. Concrete that is damaged or honeycombed must be removed to sound concrete and replaced with drypack, mortar, or concrete as hereinafter specified. Where large bulges and abrupt irregularities protrude, the protrusions shall be reduced by bush-hammering and grinding. Drypack filling shall be used for holes left by the removal of fasteners from the ends of form tie rods.

#### 9-14 STEEL REINFORCEMENT

##### (a) General

The Contractor shall furnish deformed steel bar in accordance with the drawings and these specifications. The Contractor shall prepare, clean, cut, bend and place all reinforcements, as shown on the detail drawings or as otherwise directed. The Contractor shall furnish all chains, supports and ties. All reinforcement shall be reasonably free from loose, flaky rust and scale, and free from oil, grease and other coating which might destroy or reduce its bond with concrete.

##### (b) Relationship of Reinforcement to Concrete Surfaces

The distance from the edge of the main reinforcement to the concrete surface shall be 5 cm except such portion as shown in the drawings. The concrete covering for stirrups, spacer bars, and similar secondary reinforcement may be reduced by the diameter of such bars, unless otherwise indicated.

##### (c) Lapping

Lapping length at joints of the reinforcing bar shall be at least thirty times of the diameter of bar and shall be bound by steel wire.

##### (d) Supports

All reinforcements shall be secured in place by use of metal or concrete supports, spacers or ties. Such supports shall be of sufficient strength to maintain the reinforcement in place throughout the concreting operation. The supports shall be used in such a manner that they will not be exposed or contribute in any way to the discoloration or deterioration of the concrete.

#### 9-15 MEASUREMENT FOR PAYMENT

##### (a) Concrete

1. Measurement for payment for plain or reinforced concrete, will be based on the volume of concrete in place within the lines and grades shown on the drawings.
2. No deduction will be made for rounded or bevelled edges, or space occupied by metal work, or embedded items such as supports, spacers or ties. The cost of construction joint

treatment with the attendant loss of material shall be included in the unit price bid per cubic meter of concrete.

3. Payment at the unit prices bid shall constitute full payment for all costs for concrete work. The costs of any dewatering required to maintain dry conditions during the pouring of concrete, furnishing materials, and installing and removing such materials, shall be included in the item of Temporary Works as indicated in the Bill of Quantities.

(c) **Steel Reinforcement**

Measurement for payment for furnishing, preparing, bar cleaning, cutting, bending, and placing steel reinforcement by the Contractor will be based on the number of kilograms placed in accordance with the detailed drawings or as otherwise directed. Payment will be made for steel in laps as shown on the drawings; where bars are welded, payment will be made as if they were lapped. Payment will not be made for steel in laps or used which are solely for the convenience of the Contractor. Payment will be made at the unit price bid for steel reinforcement. No separate payment will be made for steel reinforcement supports, and the cost thereof shall be included in the unit price bid.

## PART 10 PIPE WORKS FOR IRRIGATION PIPELINE

### 10-01 GENERAL

PVC pipe will comply with AZ (8 kg/cm<sup>2</sup>) as shown on the Drawings. Fittings of pipes will comply with JIS K 6743 (Rigid Polyvinyl Chloride Pipe Fitting for Water Works) for solvent welding sockets (TS joint).

The installation of irrigation pipelines shall be carried out in accordance with the details shown on the Drawings and the instructions given by the Engineer.

### 10-02 PIPE BEDDING

The Contractor shall lay pipes not less than 100 centimeters below the ground surface as shown on the Drawings or as directed by the Engineer. The bedding material of sand below the pipes shall be placed in accordance with the Drawings and shall be well compacted to the satisfaction of the Engineer.

### 10-03 PIPE JOINTING

Before the pipes are jointed together, the Contractor shall inspect for any damage to the pipes and clean the inside and outside parts of the pipe ends and the joints as directed by the Engineer. If a TS joint is used, adhesive shall be applied to the pipe to be carefully inserted into the TS joint and held for 30 to 50 seconds.

### 10-04 EXCAVATION AND BACKFILLING

Excavation and backfill of trenches shall be carried out in accordance with PART 4 and 5, respectively.

### 10-05 INSTALLATION OF APPURTENANCE

The Contractor shall install appurtenances such as hydrants under the instruction of the Engineer.

### 10-06 FIELD TESTING

Before backfilling trenches, all pipelines and their appurtenance shall be tested at the Site to ensure proper water tightness. Field tests shall be performed by the Contractor under the direction of the Engineer. The Contractor shall prepare all necessary instrument required by the Engineer for the proper testing of pipelines.

The maximum allowable quantity of leakage per one (1) centimeter of diameter and one (1) kilometer of length shall be 100 liter/day in the pipeline.

Defects found from the above-mentioned tests shall be investigated and shall be repaired immediately at the expense of the Contractor.

10-07 MEASUREMENT FOR PAVEMENT

Measurement for payment of PVC pipes and appurtenances shall be made for the length in linear meters from end-to-end of pipes in place and no allowance will be made for lap at joints. Payment for furnishing and installing PVC pipes and appurtenances shall be made at the unit prices per linear meter for respective diameter. Unit prices shall include all costs of furnishing, transporting, jointing, perforating and placing the PVC pipes and appurtenances as described above, including the cost of all labor, materials and equipment.

## PART 11 TUBEWELL AND PUMPING EQUIPMENT

### 11-01 GENERAL

The Work to be performed under the provisions of this Part shall consist of construction of tubewell including supply of all necessary equipment and materials, drilling, electric logging, installation of casing pipe and screens, gravel packing, pumping tests, delivery and installation of deep well submersible motor pump, check and sluice valves, distribution pipeline to the existing reservoir tank, delivery and installation of booster pump, pressure tank, check and sluice valves, control facilities and all necessary to complete the Work specified hereinafter or directed by the Engineer.

### 11-02 TUBEWELL CONSTRUCTION

#### 11-02-1 Scope of Work

The tubewell shall consist of casing pipe and screen enveloped with sieved gravel sunk into vertical drilled hole. The standard design of the tubewell to be constructed under this Part is shown on the Drawings, but subject to the modification in accordance with the results of electric logging pumping tests specified in Clause 11-02-2 and 11-02-6 thereof.

The Contractor shall perform the Work as specified in this Part and in accordance with the requirements set out as follows:

- (a) In accordance with the specifications contained in this Part and as shown on the detail drawings, the Contractor shall furnish plant, labor, equipment, and materials, and perform all operation in connection with the deep well required as the suction hole for a submersible motor pump.
- (b) The exact location, depth and diameter of the hole shall be decided based on the results obtained from an electric prospecting survey which shall be executed by the Contractor.
- (c) Additional instructions in the form of additional drawings or written or verbal instructions, may be given during the progress of the work and such will not be considered to be extra work within the meaning of the specifications.

#### 11-02-2 Method of Carrying Out the Works

Prior to the commencement of the Work, the Contractor shall submit to the Engineer for approval a statement describing the methods to be employed in the Work, the type and capacity of the main rigs, and materials which the Contractor intends to supply and use for the Work, in conformity with the provisions specified hereinafter. But the approval of the Engineer shall not relieve the Contractor of his obligation to complete the Work.

##### (a) Conductor Pipe Setting

Prior to drilling work, the conductor pipe shall be set vertically to a suitable depth to prevent the collapse of the surface soil and to accommodate mud water circulation.



(b) Method of Drilling Work

The Contractor shall drill a vertical hole 300 mm (12 inches) in nominal diameter for the tubewell. The tubewell, to the depth of 200 m, shall be drilled by ordinary rotary method or by percussion method at the Contractor's option.

(c) Reaming and Washing

Once the hole is opened to the depth of 200 m, the Contractor shall make a reaming run with a full gauge bit and/or hole opener to take out all obstructions before the installation of the casing and screening. Cutting slimes shall be removed by circulating drilling fluid, operating the pump at full capacity in the case of ordinary rotary drilling, or using a sand bailer carefully in the case of the percussion method, until the sand bailer shall reach the bottom of the drilled hole smoothly without any obstruction.

(d) Electrical Logging

Electrical logging shall be made prior to the installation of the casing and screening. Resistivity and the spontaneous potential of the formation shall be measured to decide the screen position. The Contractor shall set the apparatus properly and sink the probe into the drilled hole and perform the logging under the direct supervision of the Contractor's hydrogeologist. The screen position shall be designated by the Contractor's hydrogeologist and approved by the Engineer immediately after the interpretation.

11-02-3 Casing Pipes and Screens

The materials of the steel pipe for casing and slotted pipe shall conform to the standard and tests of JIS or equivalent. The wall thickness of the 200 mm (8 inch) steel pipe shall not be less than 4.7 mm (3/16 inch). The screen shall be double galvanized or stainless wire wrapped type 200 mm (8 inch) screens with 0.5 mm slots. The assembly of casing pipes and screens shall be connected tightly with couplings or electrical welding.

11-02-4 Installation of Casing Pipes and Screens

The Contractor shall install the assembly of the casing pipe and screen specified in Clause 11-02-3 thereof in the drilled hole. The screen shall be installed correctly to fit the aquifer, immediately after interpretation of the results of the electrical logging specified in Clause 11-02-2. The assembly of casing pipe and screen of the tubewell shall be centralized through the drilled hole with centralizers at approximately every 20 m. Installation of the assembly of the casing pipe and screen shall not be commenced before packing gravel to be used is stored at the work site.

11-02-5 Gravel Packing

The annular space between the assembly of casing pipe and screen and the wall of drilled hole shall be filled with gravel, which shall be clean, washed durable gravel composed of well rounded quartzitic or andesitic particles. Gravel to be used shall be of a natural gradation ranging between the strict size limits of 4 mm and 8 mm in diameter. Gravel shall contain no limestone or other calciferous materials, no organic materials such as wood fragments and no lignite. Crushed rock or angular particles shall not be utilized as part of the gravel envelopes. The gravel envelope shall be a continuous medium completely filling the annular space between

the assembly of casing pipe and screen and the wall of the drilled hole. If the gravel surface sinks during development and the pump test, additional gravel shall be placed in the annular space.

#### 11-02-6 Continuous Pumping Test

The Contractor shall carry out a continuous pumping test under a constant pumping discharge at the rate designated by the Engineer for 72 hours at the tubewell. The discharge rate shall be measured by the Contractor at any time requested by the Engineer. Meantime, the drawdown of water level in the tubewell, if any, will be measured by the Engineer. If the pumping is discontinued by mechanical trouble or insufficient supply of fuels or lubricant within 72 hours, the Contractor shall resume the continuous pumping test after more than 6 hours idle time under the direction of the Engineer. Such pumping hours, not satisfying the test, shall not be compensated to the Contractor.

#### 11-02-7 Well Cap and Foundation

Upon satisfactory completion of the tubewell, a concrete foundation shall be made in conformity to the Drawings. The tubewell shall have a cap with a lock to prevent the entrance of foreign matter into the well and to be suitable for periodical water level observation before the installation of pumping equipment.

#### 11-03 DEEP WELL SUBMERSIBLE PUMP EQUIPMENT

##### 11-03-1 General

The Contractor shall supply and install one (1) set of deep well submersible motor pump with valves, steel riser and PVC pressure pipes and accessories specified hereinafter, in the drilled borehole as specified in Clause 11-02.

##### 11-03-2 Design Conditions

The pumping equipment shall be designed in accordance with the following conditions, but subject to modification in accordance with the interpretation of the results of the electrical logging specified in Clause 11-02-2 and pump tests in Clause 11-02-6. The Contractor shall design and provide for the Engineer's approval the all design drawings, and catalogs on the basis of the results of the interpretation of electric logging specified in Clause 11-02-1 and 11-02-2.

- (a) Type of pump : Deep well submersible motor pump
- (b) Discharge capacity per unit at rated design discharge : 330 l/min
- (c) Rated design head : 80 m
- (d) type of motor : Vertical shaft canned submersible motor

### 11-03-3 General Requirements

The pump equipment shall conform to the following requirements:

(a) Pump

The water pumps shall be deep well submersible pump. All sections of the pump and motor shall rigidly connected to maintain correct alignment of all parts. The impeller of the pump shall be made of bronze castings or approved material and main shaft shall be made of corrosion resistant material or approved material. Special attention shall be given to the pumps and motor entering the water or other foreign materials. The motor cables shall be water proof.

(b) Valves

Adequate valves shall be provided for the pump equipment. A check valve shall be provided at outlet side of pump to stop return flow when the pump stopped. The check valve shall be of a flap type and shall withstand the expected internal water pressure. The valve body shall be made of cast iron and the sealing surfaces of the valve shall be accurately machined for a complete water seal when the valve is closed.

A hand operated sluice valve shall be provided for the function of a discharge valve. The sluice valve shall be of a gate valve type and shall withstand the expected internal water pressure. The valve body shall be made of cast iron and the contact surface of seal parts shall be accurately machined for an efficient water seal when the valve is closed. Connection of the valves and pipes shall be made by flanged coupling.

(c) Pipes

Adequate sizes of pipes shall be provided for the pump equipment. The pipes shall be steel pipes for ordinary piping or equivalent and PVC pressure pipe from the outlet of the tubewell foundation to the existing reservoir tank shown on the Drawings, and shall withstand the expected internal water pressure.

(d) Control of submersible pump

The pump shall be automatically started and stopped by means of water level detecting devices provided in the existing reservoir water tank and the tubewell to be constructed in accordance with the provisions of Clause 11-02. When the water level in the existing reservoir water tank becomes lower than the designated operation water level shown in the drawings, the pump shall be capable of starting automatically. When the water level in the tubewell become lower than the designated water level determined by the interpretation of the test result specified in Clause 11-02-6 and/or when the water level in the existing reservoir water tank become higher than the designated high water level, as shown in the Drawings. The pump shall be capable of stopping automatically. Manual starting and stopping of the submersible motor pumps shall also be made from the control panel by the change over of a selecting switch.

The Contractor shall provide the panel, water level detecting devices, wiring materials and other apparatus required for the above pump control in accordance with the provisions of Clause 11-05.

#### 11-03-4 Accessories

The following accessories shall be provided for the pump equipment:

- Anchor bolts and nuts
- Floor plates and frames
- Pressure gauges or compound gauges
- Shaft couplings
- Air valves for deep well pump
- Gantry for maintenance of pump
- Other all necessary accessories and piping

#### 11-04 BOOSTER PUMP EQUIPMENT

##### 11-04-1 General

The Contractor shall supply and install one (1) set of booster pump with motor, valves, base, pressure tank, piping and accessories.

##### 11-04-2 Design Conditions

The booster pump equipment shall be designed in accordance with the following conditions.

The Contractor shall design and provide all design drawings and catalogs for the Engineers approval.

##### (a) Layout of Pump Equipment

The general arrangement of the booster pump equipment is as referred in the Drawings.

##### (b) Type of Pump

Horizontal shaft, single suction volute pump

##### (c) Discharge of Pump

500 l/min

##### (d) Quantity of Pump Set

One (1) set

##### (e) Electric Source

380 V, 3 phase, 4 wires, 50 Hz system

(f) Pressure Tank

The pressure tank and accessories shall be capable of withstanding the designed internal pressure, external loads and other loads.

11-04-3 General Requirements

The pump equipment shall conform to the following requirements. As for the valves and pipes, the provisions shown in Clause 11-03-3 shall be referred to.

(a) Pump

The pump shall be capable of operating safely and satisfactorily under any water levels and conditions. Adequate provision shall be made for the convenience of handling all parts of pumps and electric equipment during assembly or disassembly.

The pump and motor shall be coupled directly by a flexible coupling and be mounted on the common steel base which shall be fixed firmly on the operation stage by the anchor bolts and nuts.

The suction pipe of the pump with its foot valve shall be of the flange connection type, supported securely on steel anchor material and/or concrete saddles.

The motor shall be of a horizontal shaft, high starting torque, low starting current, squirrel cage induction type, drip-proof for indoor service - two (2) pole construction.

The motors shall have Class E or F insulation in JEC Standard and continuous rating at 40°C ambient temperature. Motor lead insulation shall be Class E or F and cable terminal boxes shall be provided preferably with stud-type connectors.

(b) Control of booster pump equipment

The pump shall be capable of operating and controlling automatically with the pressure control device on the pressure tank made of steel and with the control panel located in the booster pump room to feed water for the experimental farm. When the pressure in the pressure tank becomes lower than 2.4 kgf/cm<sup>2</sup>, the pump shall be capable of starting automatically.

The pump shall be capable of starting under the fully primed condition, for which initial priming is to be done by hand.

The pump shall be capable of stopping automatically when the water level in the existing reservoir tank becomes lower than the low water level and/or the pressure in the pressure tank becomes higher than 3.5 kgf/cm<sup>2</sup>. The pump shall not be started under the said water level condition.

## 11-05 CONTROL AND ELECTRICAL FACILITIES

### 11-05-1 Switch Box

Switch box shall be an indoor, wall-mounted, dust-proof type. Color for outside finish shall be the same of the existing panels in the Laboratory and Testing. The moulded case circuit breaker (MCCB) to be mounted inside the switch box shall be for motor circuit use.

### 11-05-2 Power Cable

Power cable shall be of 600 V four-core copper, 50 sq.mm, polyvinyl chloride (PVC) insulated, steel tape or wire armored, polyvinyl chloride (PVC) sheathed type with suitable cable ends.

The power cable shall conform to standard Perusahaan Umum Listrik Negara (SPLN) 43-2, 1981.

### 11-05-3 Pump Control Panel

One (1) pump control panel shall be supplied and installed in the booster pump room for operating both the deep well submersible and booster pumps. The pump control panel shall be outdoor, weather-proof, dust-proof and self-supporting type. The pump control panel shall be provided with "ON" and "OFF" push button switches and "AUTO" - "MANUAL" operation change over switch for both the deep well submersible and booster pumps.

The booster pump shall be capable of automatic start/stop operation under "AUTO" operation mode.

The pump control panel shall have the following functions:

- (1) Open-phase protection of pump motor
- (2) Protection for inching of pump motor

The moulded case circuit breakers to be mounted inside the pump control panel shall be for motor circuit use and shall have overcurrent and under-voltage tripping mechanisms.

The pump control panel shall be provided complete with potential transformers, current transformers, instruments, indicating lamps, contactors, switches, terminal blocks, wiring and other miscellaneous devices as required for proper operation of both the submersible deep well and booster pumps.

The color for the outside finish coat shall be subject to the Employer's approval.

### 11-05-4 Power Cable Laying

Power cable laying work shall be carried out in accordance with relevant drawings. In the Laboratory and Testing, the power cable shall be laid in steel conduit pipe beside the existing cable. The steel conduit pipe shall be painted the same color as the existing conduit pipes.

## PART 12 AUXILIARY FACILITIES

### 12-01 SCOPE

In accordance with the Specifications and as shown on the drawings or otherwise directed by the Engineer, the Contractor shall furnish labor, equipment and materials and perform all operations in connection with the construction of buildings, including earthworks, grading for the houses foundation, concrete works, construction of columns, walls, roof, windows, doors, finishings, electrical facilities, water supply and drainage facilities and other related works and facilities.

### 12-02 MATERIALS

All materials used in the building works shall be subject to the Engineer's approval. The Contractor shall submit to the Engineer, samples of the said materials prior to commencement of these works for his approval.

### 12-03 BRICK WORKS

Local products can be used and all bricks shall be laid after applying mortar. Mortar shall be prepared in the same way as for plastering. It shall be applied firmly to raked out and well wetted joints with a pointing trowel and well pressed in. All superfluous mortar shall be removed with a trowel.

External surfaces shall be finished with weather struck pointing and internal surfaces given flush pointing.

### 12-04 ROOFING

The construction method shall conform to Indonesian specifications.

### 12-05 JOINERY WORKS

Wooden doors and windows shall be manufactured in Indonesia from local timber.

Articles of buildings hardware shall be of approved type and well finished. Samples shall be submitted to the Engineer for approval before use. Screws shall be of the same metal as the main article.

All articles shall be fixed in a secure and efficient manner. Articles damaged during fixing shall be removed and newly fixed at the Contractor's expense. The surface of joinery where defective shall be made good.

Glass shall be 3 millimeters sheet glass of good quality, free from specks, bubbles, and other defects. Sheet glass shall be plain and clear. The glass panes shall be fixed either with wood beads or shall be bedded in oil putty, sprigged, firmly back puttied and finished to a chamfer. Rabbets shall be painted one coat of oil paint before glazing. Each pane shall be truly square.

### 12-06 PAINTING

Painting shall not be carried out to exterior surfaces in wet weather. All surfaces must be thoroughly dry before applying paint. Painting shall not

be carried out in windy weather as the paint is likely to be smeared by dust.

Contents of drums or tins shall be stirred well before using. When more than one coat is required to be done, each coat shall vary slightly in shade and shall be accepted by the Engineer before the next coat is started. Each coat should be thoroughly dry before succeeding coat is applied.

All brushes, tools, pots, etc. used in carrying out the work shall be clean and free from foreign matter and shall be thoroughly cleaned out before being used for different type of material. Paint shall be applied with proper paint brushes of good quality.

In using proprietary brands of paint, the materials shall be mixed, prepared and applied strictly in accordance with manufacturer's instructions.

#### 12-07 ELECTRICAL AND WATER SUPPLY AND DRAINAGE WORKS

All electrical works and water supply and drainage works shall be as shown on the drawings and Indonesian standard specifications or directed by the Engineer.



## 第六章 図 面

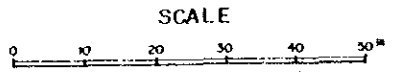
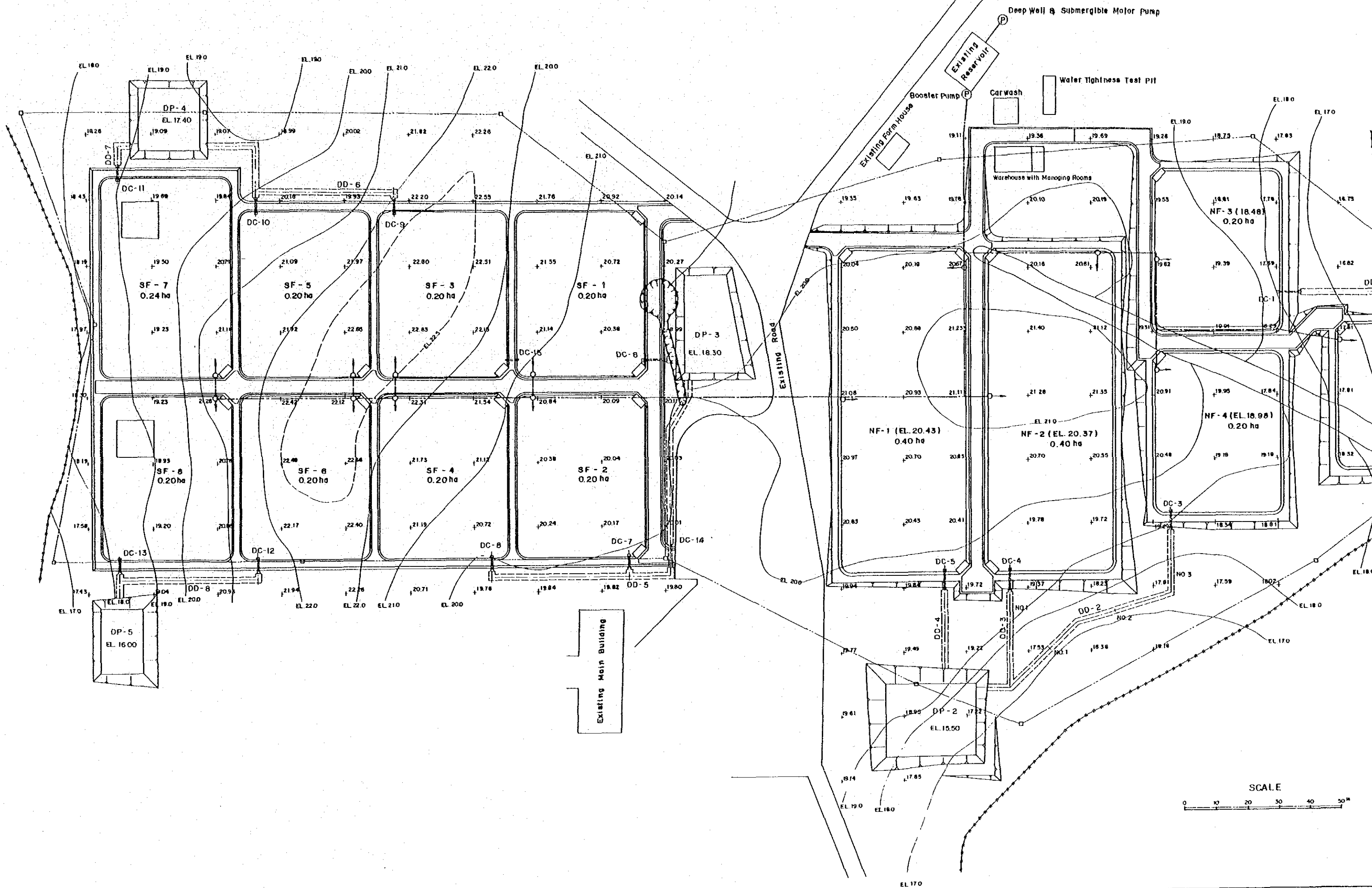

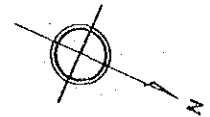
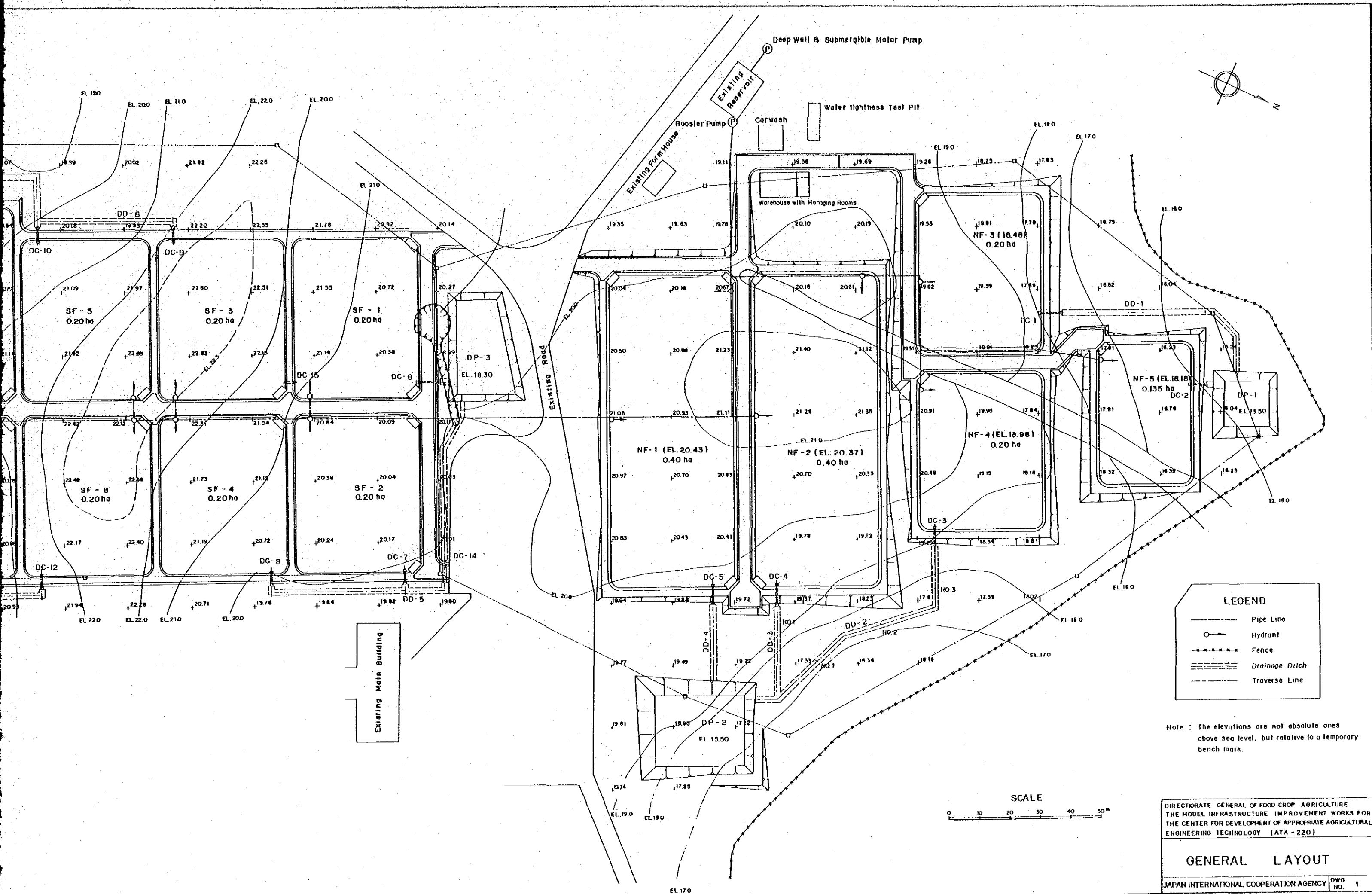

**LEGEND**

- Pipe Line
- Hydrant
- Fence
- Drainage Ditch
- Traverse Line

Note : The elevations are not absolute ones above sea level, but relative to a temporary bench mark.

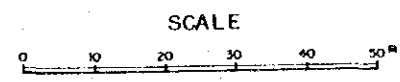

DIRECTORATE GENERAL OF FOOD CROP AGRICULTURE  
 THE MODEL INFRASTRUCTURE IMPROVEMENT WORKS FOR  
 THE CENTER FOR DEVELOPMENT OF APPROPRIATE AGRICULTURAL  
 ENGINEERING TECHNOLOGY (ATA - 220)

**GENERAL LAYOUT**

JAPAN INTERNATIONAL COOPERATION AGENCY DWG. NO. 1

**MR**

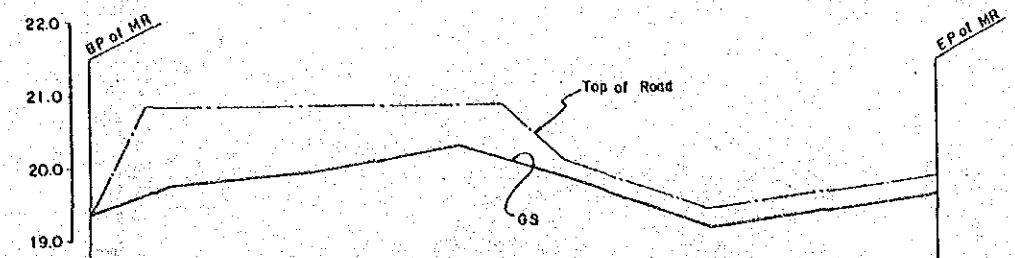

ORIGINAL GROUND SURFACE ELEVATION	19.35	19.64	19.75	19.93	20.29	20.19	20.11	19.84	19.15	19.16	19.40	19.64
TOP OF ROAD	19.35	20.85	20.85	20.0	20.0	20.85	20.85	20.09	19.40	19.16	19.65	19.89
DISTANCE	0	7.5	30	200	200	3.5	25	90	200	1.0	16.5	150
REDUCED DISTANCE	0	7.5	10.5	30.5	50.5	54.0	56.5	65.5	85.5	86.5	103.0	118.0
CURVE	90°											

**SR-1**

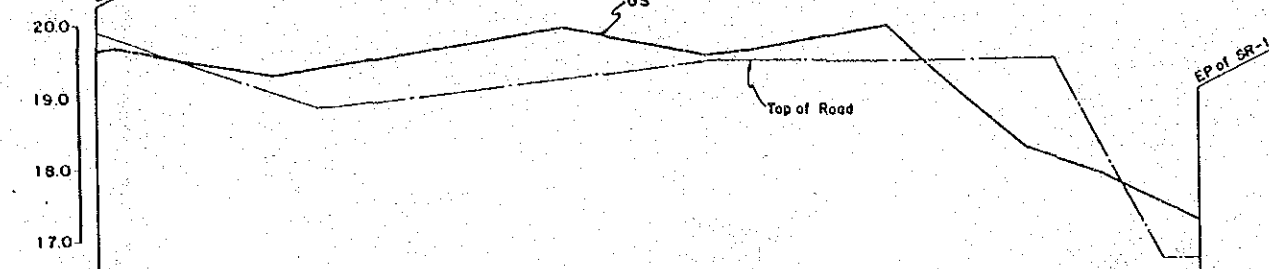

ORIGINAL GROUND SURFACE ELEVATION	19.64	19.67	19.33	19.31	19.42	19.45	19.59	19.92	18.21	18.07	18.03	17.85	17.68	17.40	17.25	17.15	
TOP OF ROAD	19.89	19.72	19.12	19.09	18.85	18.85	18.98	19.21	19.45	19.45	19.26	19.85	17.66	16.65	16.65	16.65	
DISTANCE	0	5.0	17.5	1.0	7.0	2.0	11.0	200	200	4.0	1.0	5.0	3.5	5.5	30	20	
REDUCED DISTANCE	0	5.0	22.5	23.5	30.5	32.5	43.5	63.5	83.5	87.5	89.5	109.5	129.5	134.5	139.5	143.0	148.5
CURVE	90°												45°		45°		

**SR-2**

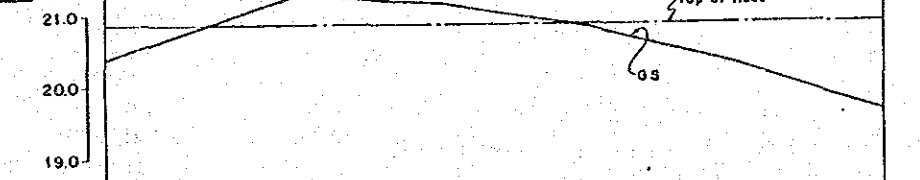

ORIGINAL GROUND SURFACE ELEVATION	20.38	20.58	21.26	21.14	20.81	20.30	19.66	
TOP OF ROAD	20.85	20.85	20.85	20.85	20.85	20.85	20.85	
DISTANCE	0	6.0	200	200	200	200	20	
REDUCED DISTANCE	0	6.0	260	460	660	860	1060	
CURVE	90°							

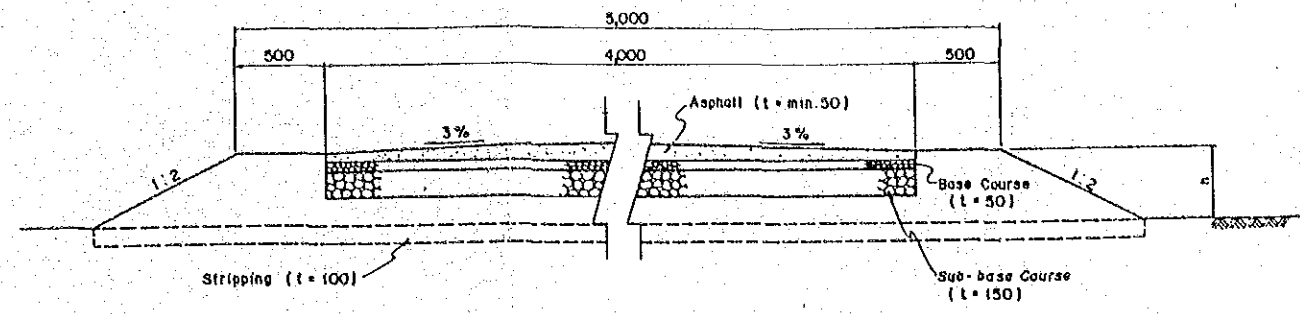

TYPICAL CROSS SECTION OF MAIN ROAD

h = approx. 400 for field  
250 for others

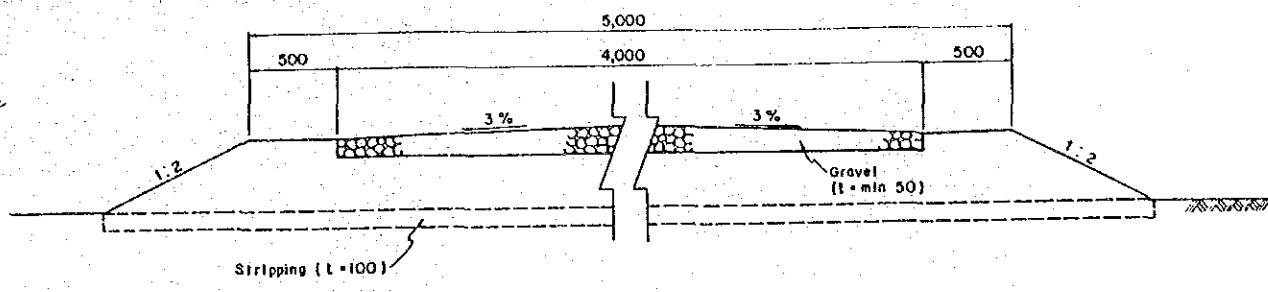
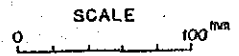

TYPICAL CROSS SECTION OF SECONDARY ROAD

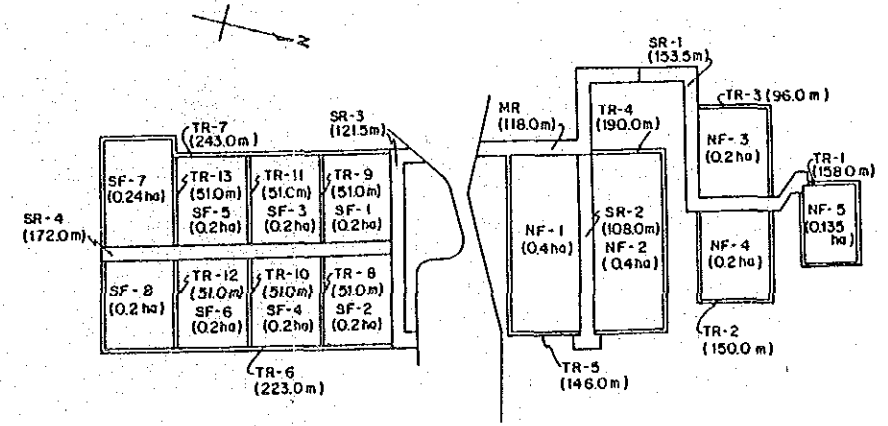
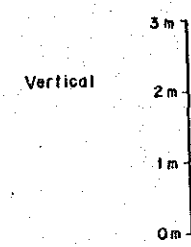
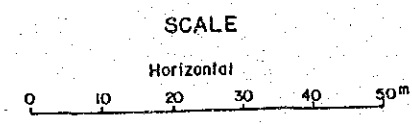

DIRECTORATE GENERAL OF FOOD CROP AGRICULTURE  
THE MODEL INFRASTRUCTURE IMPROVEMENT WORKS FOR  
THE CENTER FOR DEVELOPMENT OF APPROPRIATE AGRICULTURAL  
ENGINEERING TECHNOLOGY (ATA - 220)

**FARM ROAD (1/4)**

JAPAN INTERNATIONAL COOPERATION AGENCY DWG. NO. 2

SR-3

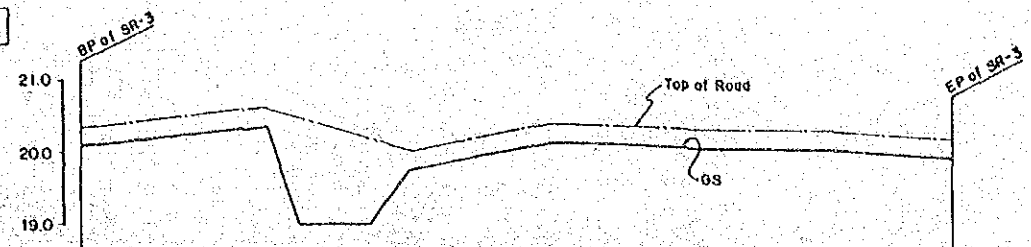

ORIGINAL GROUND SURFACE ELEVATION	20.11	20.16	20.15	20.35	19.00	19.00	19.75	20.11	20.04	19.95	19.92	19.89
TOP OF ROAD	20.36	20.41	20.44	20.60	20.47	20.17	20.00	20.36	20.29	20.20	20.17	20.14
DISTANCE	0	5.0	3.5	17.0	4.5	10.0	5.5	20.0	20.0	9.5	3.5	3.0
REDUCED DISTANCE	0	5.0	8.5	25.5	30.0	40.0	45.5	65.5	85.5	95.0	108.5	111.5
CURVE	90°						90°					

TR-1

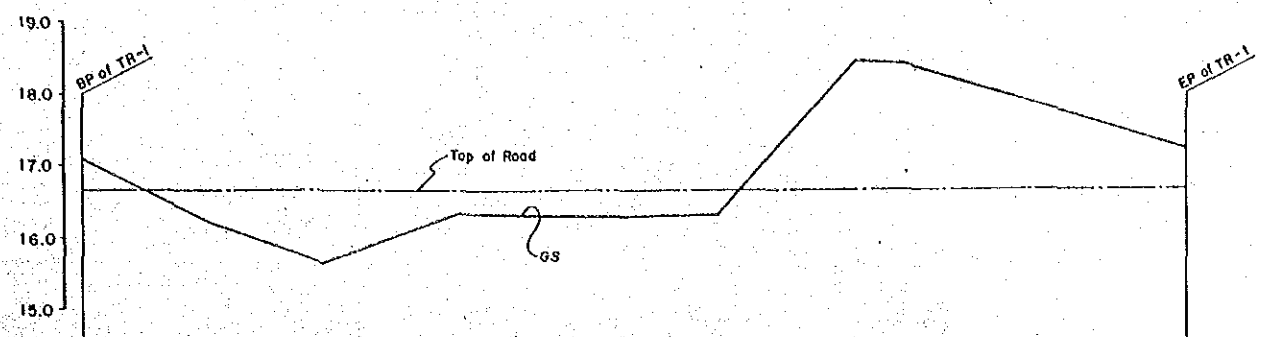

ORIGINAL GROUND SURFACE ELEVATION	17.11	16.19	15.78	16.33	16.29	16.29	16.30	18.45	18.44	18.41	17.81	17.21
TOP OF ROAD	16.65	16.65	16.65	16.65	16.65	16.65	16.65	16.65	16.65	16.65	16.65	16.65
DISTANCE	0	180	120	40	200	200	50	120	200	200	200	200
REDUCED DISTANCE	0	180	300	340	540	740	790	910	1110	1130	1180	1380
CURVE	90°			90°			90°					

SR-4



ORIGINAL GROUND SURFACE ELEVATION	20.11	20.14	20.89	21.65	22.40	22.71	22.33	21.25	19.25	18.34
TOP OF ROAD	20.36	20.39	21.14	21.90	22.65	22.96	22.56	21.50	19.48	18.60
DISTANCE	0	140	200	200	200	200	200	200	180	180
REDUCED DISTANCE	0	140	340	540	740	940	1140	1340	1540	1720
CURVE										

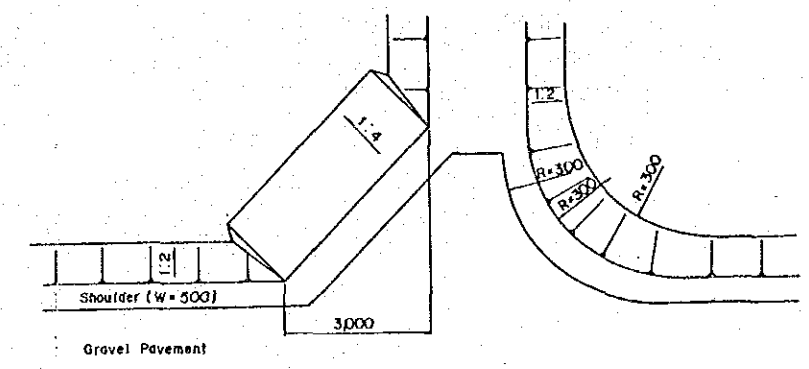

DETAIL OF ENTRANCE

TR-2

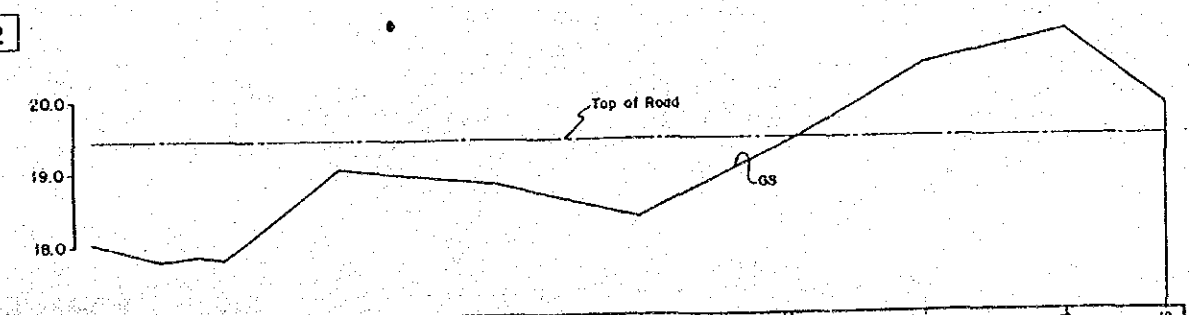

ORIGINAL GROUND SURFACE ELEVATION	18.05	17.80	17.84	17.80	19.05	18.86	18.83	18.39	19.35	19.41	20.46	20.93	19.86
TOP OF ROAD	19.45	19.45	19.45	19.45	19.45	19.45	19.45	19.45	19.45	19.45	19.45	19.45	19.45
DISTANCE	0	9.5	4.5	4.0	16.0	19.0	3.0	20.0	19.0	20.0	20.0	14.0	14.0
REDUCED DISTANCE	0	9.5	14.0	18.0	34.0	53.0	56.0	76.0	95.0	115.0	135.0	149.0	163.0
CURVE	90°						90°						

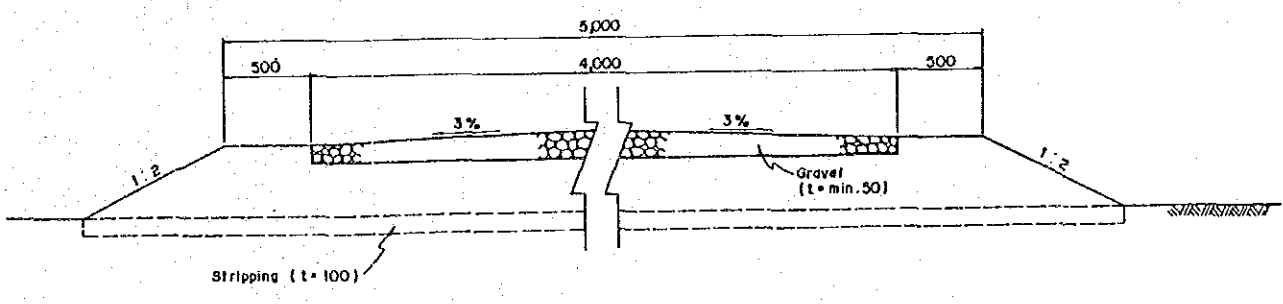

TYPICAL CROSS SECTION OF SECONDARY ROAD

DIRECTORATE GENERAL OF FOOD CROP AGRICULTURE  
 THE MODEL INFRASTRUCTURE IMPROVEMENT WORKS FOR  
 THE CENTER FOR DEVELOPMENT OF APPROPRIATE AGRICULTURAL  
 ENGINEERING TECHNOLOGY (ATA - 220)

FARM ROAD (2/4)

JAPAN INTERNATIONAL COOPERATION AGENCY DWG. NO. 3



TR-7

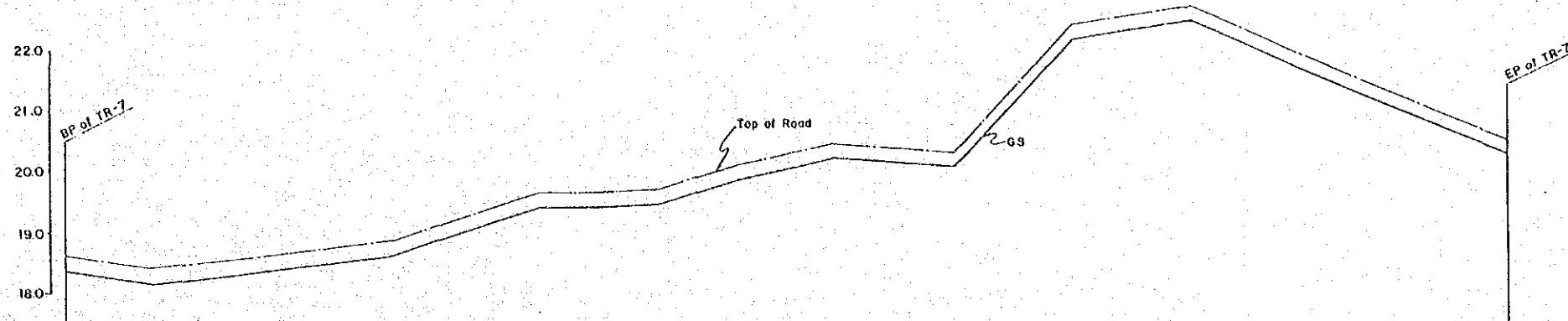

ORIGINAL GROUND SURFACE ELEVATION	18.36	18.16	18.39	18.62	18.89	19.45	19.53	19.77	19.94	19.98	20.27	20.13	22.26	22.35	21.74	20.90	20.34
TOP OF ROAD	18.61	18.41	18.64	18.87	19.14	19.70	19.78	19.96	20.19	20.23	20.52	20.38	22.51	22.60	21.99	21.15	20.59
DISTANCE	0	14.0	20.0	20.0	8.0	17.0	20.0	6.0	8.0	2.0	14.0	20.0	20.0	20.0	20.0	20.0	14.0
REDUCED DISTANCE	0	14.0	34.0	54.0	62.0	79.0	99.0	105.0	113.0	115.0	129.0	149.0	169.0	189.0	209.0	229.0	243.0
CURVE	----- ----- ----- ----- ----- ----- ----- ----- ----- ----- ----- ----- ----- ----- ----- ----- -----																

TR-8

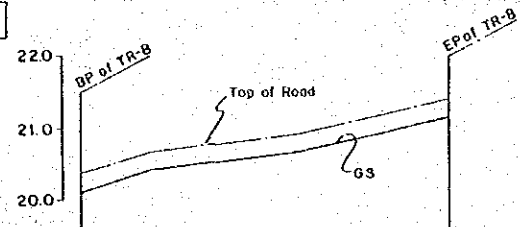

ORIGINAL GROUND SURFACE ELEVATION	20.12	20.43	20.68	21.12	21.14
TOP OF ROAD	20.37	20.68	20.95	21.37	21.39
DISTANCE	0	100	200	200	10
REDUCED DISTANCE	0	100	300	500	510
CURVE	----- ----- ----- ----- -----				

TR-9

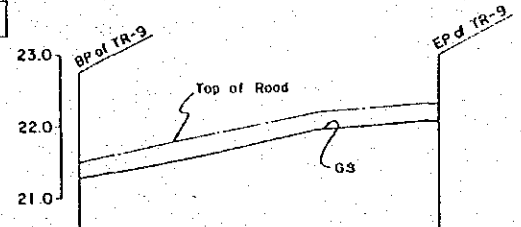

ORIGINAL GROUND SURFACE ELEVATION	21.25	21.54	21.93	22.06
TOP OF ROAD	21.50	21.79	22.18	22.31
DISTANCE	0	140	200	170
REDUCED DISTANCE	0	140	340	510
CURVE	----- ----- ----- -----			

TR-10

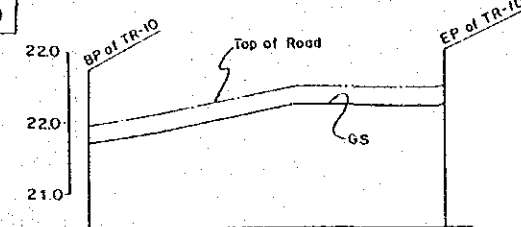

ORIGINAL GROUND SURFACE ELEVATION	21.71	21.86	22.24	22.51	22.54
TOP OF ROAD	21.96	22.11	22.49	22.68	22.71
DISTANCE	0	100	200	200	10
REDUCED DISTANCE	0	100	300	500	510
CURVE	----- ----- ----- ----- -----				

TR-11

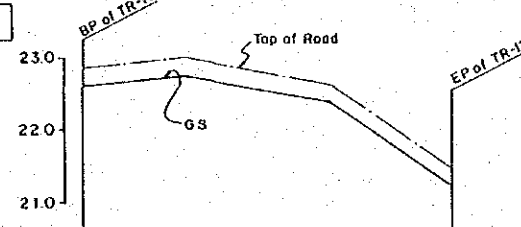

ORIGINAL GROUND SURFACE ELEVATION	22.60	22.73	22.34	21.16
TOP OF ROAD	22.85	22.96	22.99	21.41
DISTANCE	0	140	200	170
REDUCED DISTANCE	0	140	340	510
CURVE	----- ----- ----- -----			

TR-12

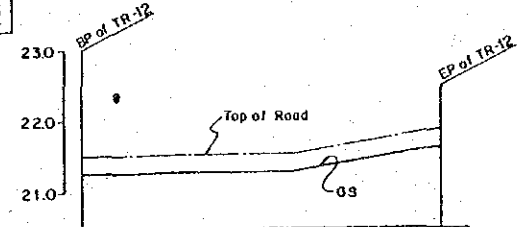

ORIGINAL GROUND SURFACE ELEVATION	21.25	21.27	21.29	21.62	21.81
TOP OF ROAD	21.50	21.52	21.54	21.87	21.89
DISTANCE	0	100	200	200	10
REDUCED DISTANCE	0	100	300	500	510
CURVE	----- ----- ----- ----- -----				

TR-13

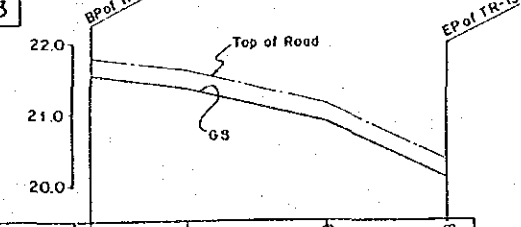

ORIGINAL GROUND SURFACE ELEVATION	21.54	21.33	20.86	20.06
TOP OF ROAD	21.79	21.60	21.13	20.33
DISTANCE	0	140	200	170
REDUCED DISTANCE	0	140	340	510
CURVE	----- ----- ----- -----			

DIRECTORATE GENERAL OF FOOD CROP AGRICULTURE  
THE MODEL INFRASTRUCTURE IMPROVEMENT WORKS FOR  
THE CENTER FOR DEVELOPMENT OF APPROPRIATE AGRICULTURAL  
ENGINEERING TECHNOLOGY (ATA-220)

FARM ROAD (4/4)

JAPAN INTERNATIONAL COOPERATION AGENCY DWG. NO. 5



TS TEE	φ100 x φ100	-1
TS VALVE SOCKET	φ100	-2
MALLEABLE TEE	φ100 x φ80	-1
MALLEABLE REDUCER	φ100 x φ80	-1
MALLEABLE REDUCER	φ80 x φ65	-1
MALLEABLE REDUCER	φ65 x φ50	-1
MALLEABLE BEND	φ50 x 90°	-1
MALLEABLE NIPPLE	φ50	-1
STEEL PIPE	φ80 x 1000	-1
HYDRANT VALVE	φ65	-1
HYDRANT VALVE BOX TYPE B		-1

TS VALVE SOCKET	φ100	-1
MALLEABLE REDUCER	φ100 x φ80	-1
MALLEABLE REDUCER	φ80 x φ65	-1
MALLEABLE REDUCER	φ65 x φ50	-1
MALLEABLE BEND	φ50 x 90°	-1
MALLEABLE NIPPLE	φ50	-1
MALLEABLE NIPPLE	φ65	-1
STEEL PIPE	φ80 x 1000	-1

TS BEND	φ100 x 90°	-1
TS VALVE SOCKET	φ100	-2
MALLEABLE TEE	φ100 x φ80	-1
MALLEABLE REDUCER	φ80 x φ65	-1
MALLEABLE REDUCER	φ65 x φ50	-1
MALLEABLE NIPPLE	φ50	-1
STEEL PIPE	φ80 x 1000	-1
HYDRANT VALVE	φ65	-1
HYDRANT VALVE BOX TYPE B		-1

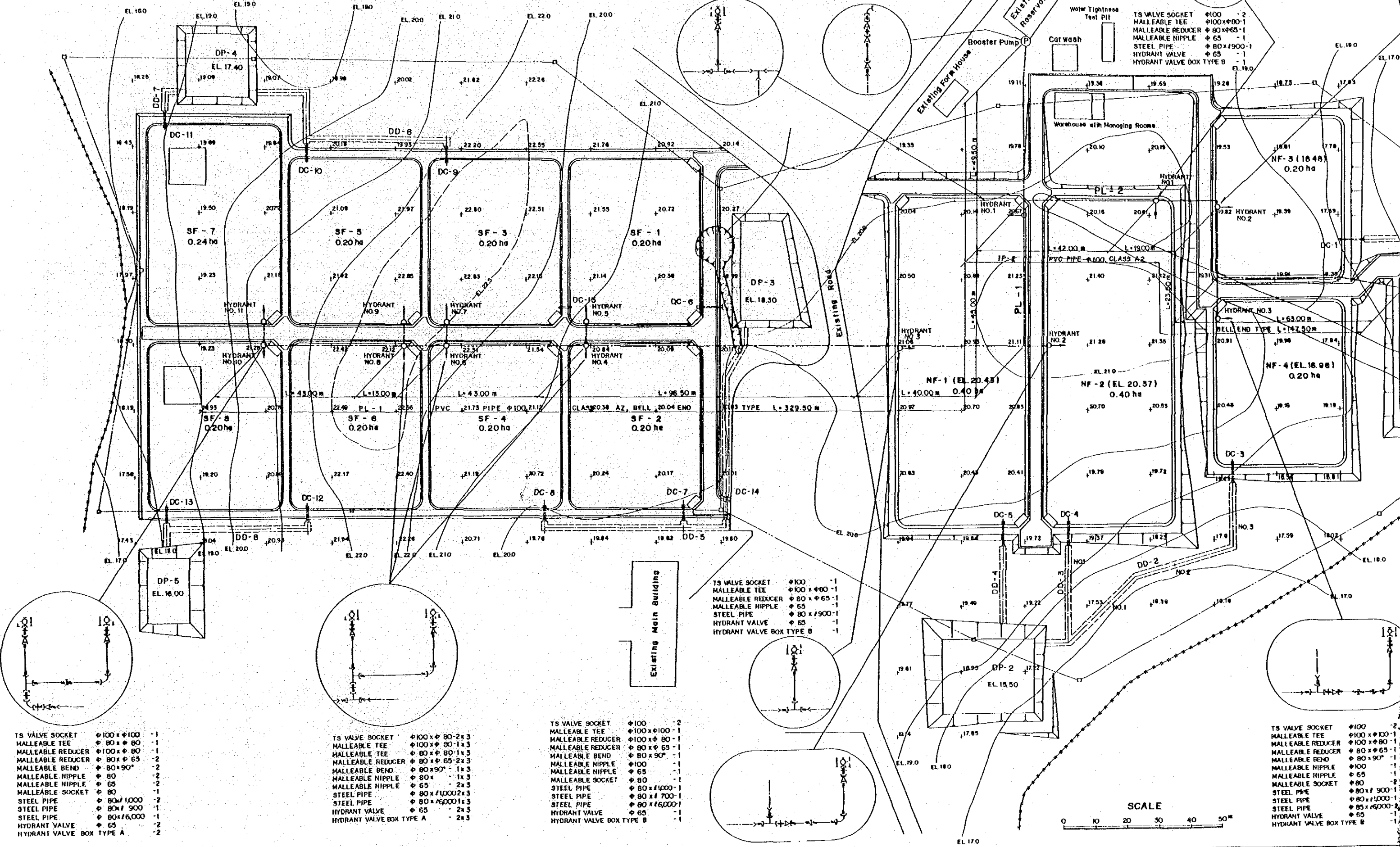

TS VALVE SOCKET	φ100 x φ100	-1
MALLEABLE TEE	φ80 x φ80	-1
MALLEABLE REDUCER	φ100 x φ80	-1
MALLEABLE REDUCER	φ80 x φ65	-2
MALLEABLE BEND	φ80 x 90°	-2
MALLEABLE NIPPLE	φ80	-2
MALLEABLE NIPPLE	φ65	-2
MALLEABLE SOCKET	φ80	-1
STEEL PIPE	φ80 x 1000	-2
STEEL PIPE	φ80 x 900	-1
STEEL PIPE	φ80 x 600	-1
HYDRANT VALVE	φ65	-2
HYDRANT VALVE BOX TYPE A		-2

TS VALVE SOCKET	φ100 x φ80	-2 x 3
MALLEABLE TEE	φ100 x φ80	-1 x 3
MALLEABLE TEE	φ80 x φ80	-1 x 3
MALLEABLE REDUCER	φ80 x φ65	-2 x 3
MALLEABLE BEND	φ80 x 90°	-1 x 3
MALLEABLE NIPPLE	φ80	-1 x 3
MALLEABLE NIPPLE	φ65	-2 x 3
STEEL PIPE	φ80 x 1000	-2 x 3
STEEL PIPE	φ80 x 900	-1 x 3
STEEL PIPE	φ80 x 600	-1 x 3
HYDRANT VALVE	φ65	-2 x 3
HYDRANT VALVE BOX TYPE A		-2 x 3

TS VALVE SOCKET	φ100	-2
MALLEABLE TEE	φ100 x φ100	-1
MALLEABLE REDUCER	φ100 x φ80	-1
MALLEABLE REDUCER	φ80 x φ65	-1
MALLEABLE BEND	φ80 x 90°	-1
MALLEABLE NIPPLE	φ100	-1
MALLEABLE NIPPLE	φ65	-1
MALLEABLE SOCKET	φ80	-1
STEEL PIPE	φ80 x 1000	-1
STEEL PIPE	φ80 x 700	-1
STEEL PIPE	φ80 x 600	-1
HYDRANT VALVE	φ65	-1
HYDRANT VALVE BOX TYPE B		-1

TS VALVE SOCKET	φ100	-2
MALLEABLE TEE	φ100 x φ100	-1
MALLEABLE REDUCER	φ100 x φ80	-1
MALLEABLE REDUCER	φ80 x φ65	-1
MALLEABLE BEND	φ80 x 90°	-1
MALLEABLE NIPPLE	φ100	-1
MALLEABLE NIPPLE	φ65	-1
MALLEABLE SOCKET	φ80	-1
STEEL PIPE	φ80 x 1000	-1
STEEL PIPE	φ80 x 700	-1
STEEL PIPE	φ80 x 600	-1
HYDRANT VALVE	φ65	-1
HYDRANT VALVE BOX TYPE B		-1

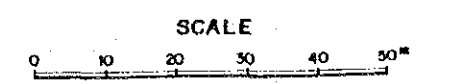



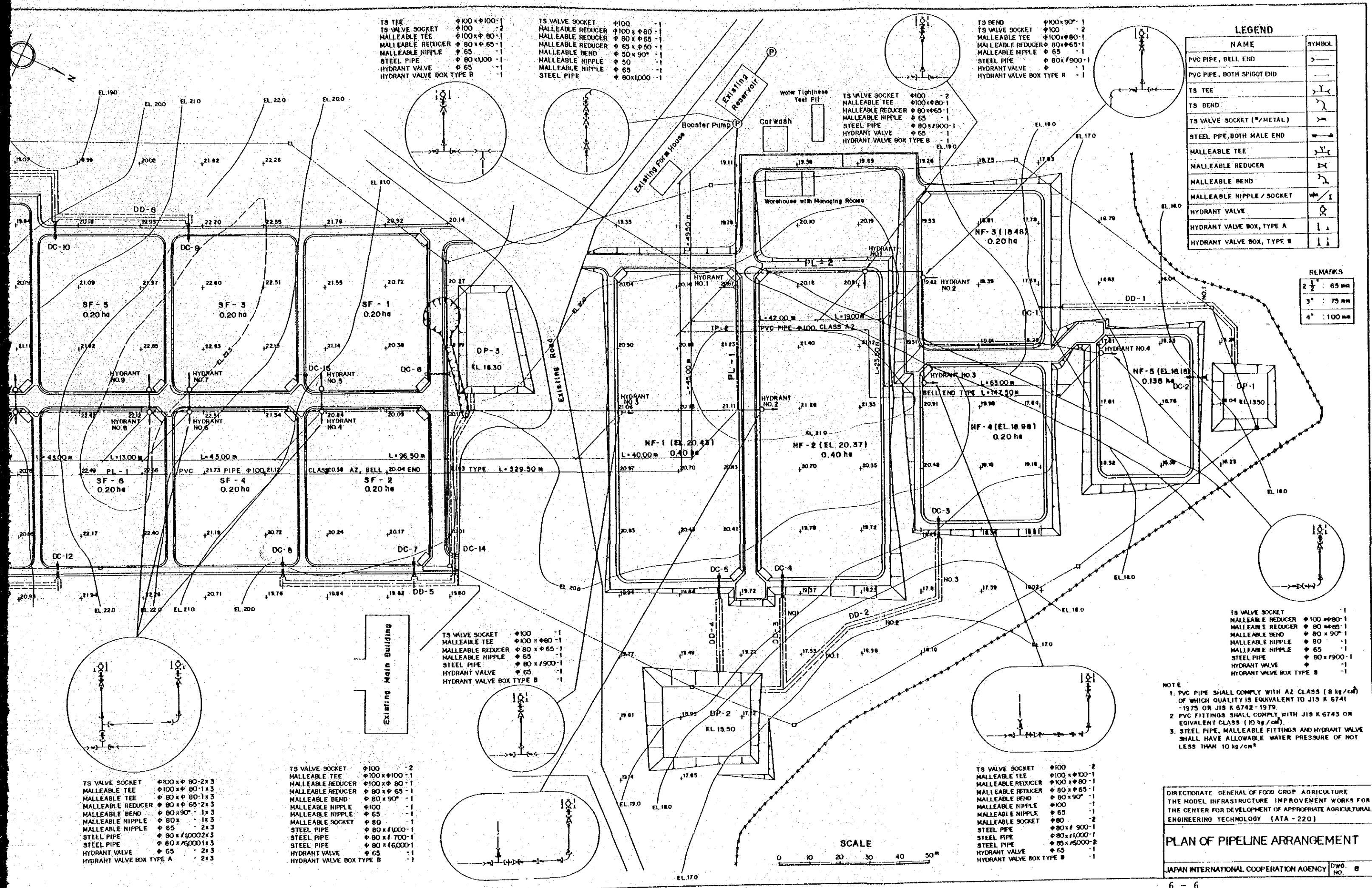

TS TEE	φ100 x φ100-1	-1
TS VALVE SOCKET	φ100	-2
MALLEABLE TEE	φ100 x φ80-1	-1
MALLEABLE REDUCER	φ80 x φ65-1	-1
MALLEABLE NIPPLE	φ65	-1
STEEL PIPE	φ80 x φ1000-1	-1
HYDRANT VALVE	φ65	-1
HYDRANT VALVE BOX TYPE B		-1

TS BEND	φ100 x 90°-1	-1
TS VALVE SOCKET	φ100	-2
MALLEABLE TEE	φ100 x φ80-1	-1
MALLEABLE REDUCER	φ80 x φ65-1	-1
MALLEABLE NIPPLE	φ65	-1
STEEL PIPE	φ80 x φ900-1	-1
HYDRANT VALVE	φ65	-1
HYDRANT VALVE BOX TYPE B		-1

LEGEND	
NAME	SYMBOL
PVC PIPE, BELL END	—
PVC PIPE, BOTH SPIGOT END	—
TS TEE	⊥
TS BEND	∩
TS VALVE SOCKET (1/2" METAL)	⊕
STEEL PIPE, BOTH MALE END	—
MALLEABLE TEE	⊥
MALLEABLE REDUCER	⊥
MALLEABLE BEND	∩
MALLEABLE NIPPLE / SOCKET	⊥
HYDRANT VALVE	⊕
HYDRANT VALVE BOX, TYPE A	⊕
HYDRANT VALVE BOX, TYPE B	⊕

REMARKS	
2 1/2"	: 65 mm
3"	: 75 mm
4"	: 100 mm

TS VALVE SOCKET	φ100	-1
MALLEABLE TEE	φ100 x φ80-1	-1
MALLEABLE REDUCER	φ80 x φ65-1	-1
MALLEABLE BEND	φ80 x 90°-1	-1
MALLEABLE NIPPLE	φ65	-1
STEEL PIPE	φ80 x φ900-1	-1
HYDRANT VALVE	φ65	-1
HYDRANT VALVE BOX TYPE B		-1

TS VALVE SOCKET	φ100	-1
MALLEABLE REDUCER	φ100 x φ80-1	-1
MALLEABLE REDUCER	φ80 x φ65-1	-1
MALLEABLE BEND	φ80 x 90°-1	-1
MALLEABLE NIPPLE	φ80	-1
MALLEABLE NIPPLE	φ65	-1
STEEL PIPE	φ80 x φ900-1	-1
HYDRANT VALVE	φ65	-1
HYDRANT VALVE BOX TYPE B		-1

NOTE  
 1. PVC PIPE SHALL COMPLY WITH AZ CLASS (8 kg/cm<sup>2</sup>) OF WHICH QUALITY IS EQUIVALENT TO JIS K 6741-1975 OR JIS K 6742-1979.  
 2. PVC FITTINGS SHALL COMPLY WITH JIS K 6743 OR EQUIVALENT CLASS (10 kg/cm<sup>2</sup>).  
 3. STEEL PIPE, MALLEABLE FITTINGS AND HYDRANT VALVE SHALL HAVE ALLOWABLE WATER PRESSURE OF NOT LESS THAN 10 kg/cm<sup>2</sup>.

TS VALVE SOCKET	φ100 x φ80-2 x 3	-1
MALLEABLE TEE	φ100 x φ80-1 x 3	-1
MALLEABLE TEE	φ80 x φ80-1 x 3	-1
MALLEABLE REDUCER	φ80 x φ65-2 x 3	-1
MALLEABLE BEND	φ80 x 90°-1 x 3	-1
MALLEABLE NIPPLE	φ80 x -1 x 3	-1
MALLEABLE NIPPLE	φ65 -2 x 3	-1
STEEL PIPE	φ80 x φ1000-2 x 3	-1
STEEL PIPE	φ80 x φ900-1 x 3	-1
HYDRANT VALVE	φ65 -2 x 3	-1
HYDRANT VALVE BOX TYPE A	-2 x 3	-1

TS VALVE SOCKET	φ100	-2
MALLEABLE TEE	φ100 x φ100-1	-1
MALLEABLE REDUCER	φ100 x φ80-1	-1
MALLEABLE REDUCER	φ80 x φ65-1	-1
MALLEABLE BEND	φ80 x 90°-1	-1
MALLEABLE NIPPLE	φ100	-1
MALLEABLE NIPPLE	φ65	-1
MALLEABLE SOCKET	φ80	-1
STEEL PIPE	φ80 x φ1000-1	-1
STEEL PIPE	φ80 x φ700-1	-1
STEEL PIPE	φ80 x φ600-1	-1
HYDRANT VALVE	φ65	-1
HYDRANT VALVE BOX TYPE B		-1

TS VALVE SOCKET	φ100	-2
MALLEABLE TEE	φ100 x φ100-1	-1
MALLEABLE REDUCER	φ100 x φ80-1	-1
MALLEABLE REDUCER	φ80 x φ65-1	-1
MALLEABLE BEND	φ80 x 90°-1	-1
MALLEABLE NIPPLE	φ100	-1
MALLEABLE NIPPLE	φ65	-1
MALLEABLE SOCKET	φ80	-2
STEEL PIPE	φ80 x φ900-1	-1
STEEL PIPE	φ80 x φ1000-1	-1
STEEL PIPE	φ80 x φ600-2	-1
HYDRANT VALVE	φ65	-1
HYDRANT VALVE BOX TYPE B		-1

DIRECTORATE GENERAL OF FOOD CROP AGRICULTURE  
 THE MODEL INFRASTRUCTURE IMPROVEMENT WORKS FOR  
 THE CENTER FOR DEVELOPMENT OF APPROPRIATE AGRICULTURAL  
 ENGINEERING TECHNOLOGY (ATA-220)

PLAN OF PIPELINE ARRANGEMENT

JAPAN INTERNATIONAL COOPERATION AGENCY Dwg. NO. 6

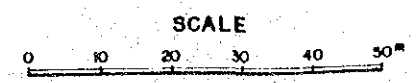

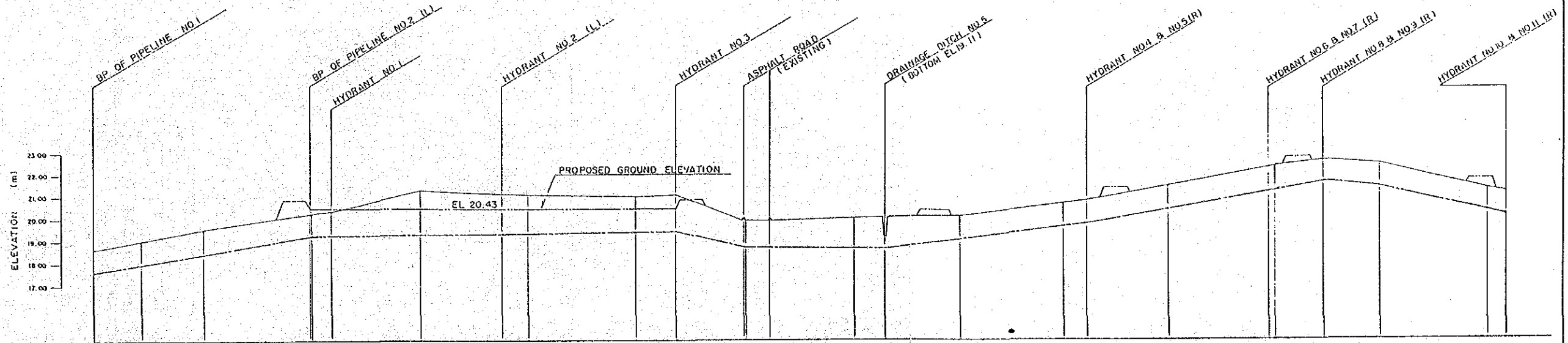

PIPE CENTER ELEVATION L: DISTANCE, I: GRADIENT	L: 49.50 m I: 3.23%		L: 84.50 m I: 0.24%		L: 15.50 m I: 4.52%		L: 32.50 m I: 0.31%		L: 48.50 m I: 2.47%		L: 56.00 m I: 3.39%		L: 13.50 m I: 1.49%		L: 22.50 m I: 4.41%											
	ORIGINAL GROUND SURFACE ELEVATION	18.50	19.00	19.50	20.20	20.20	21.11	21.05	21.00	21.06	19.95	19.95	20.00	20.70	20.85	22.45	22.70	22.55	21.40	21.25						
REDUCED DISTANCE	0.00	11.00	25.00	45.50	50.00	64.00	75.00	84.00	100.00	125.00	134.00	159.50	175.00	182.00	195.50	207.00	225.50	250.00	265.00	269.50	272.00	285.00	307.50	329.50	352.00	
DISTANCE	0.00	11.00	14.00	24.00	24.00	4.00	21.00	19.00	6.00	25.00	9.00	15.50	19.50	7.00	18.00	25.00	5.50	19.50	23.50	11.50	13.50	25.00	4.50	29.50	34.00	
STATION	B.P.	+11.00	NO. 1	+18.50	+10.75	+4.50	NO. 3	+19.00	NO. 4	+9.00	NO. 5	+5.50	NO. 6	+7.00	NO. 8	+5.50	NO. 10	+11.50	NO. 11	+23.50	+11.50	NO. 12	NO. 13	+4.50	NO. 14	+22.00
HORIZONTAL ANGLE	IA = 5°13'										IA = 90°00'															

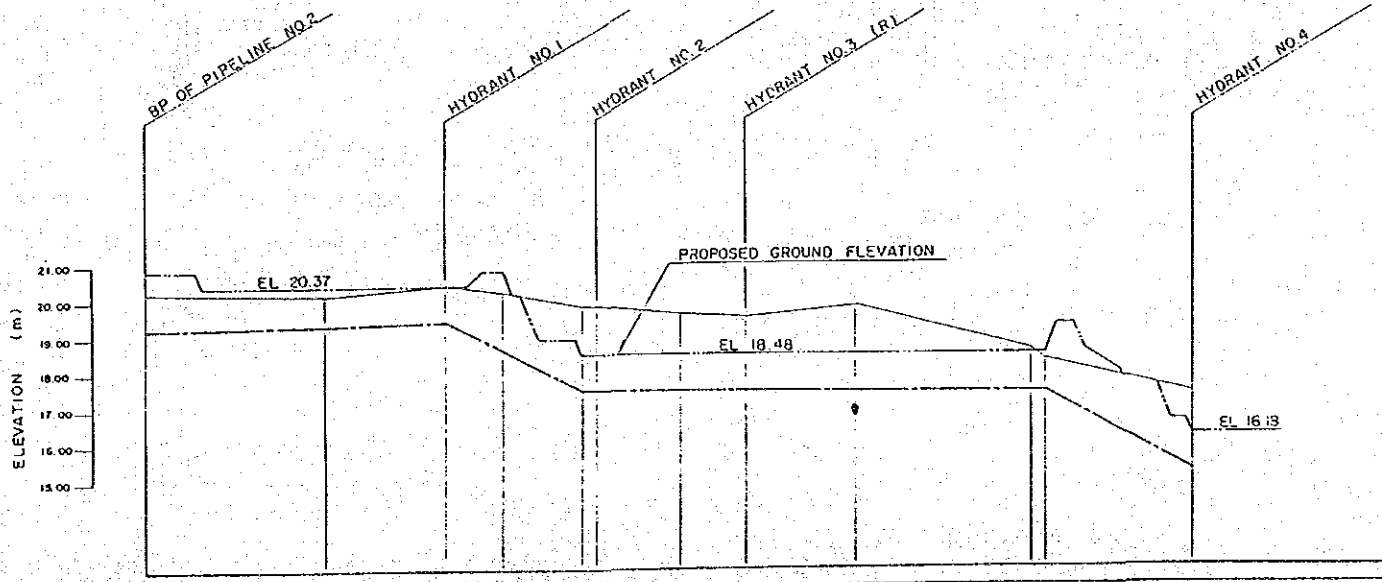

PIPE CENTER ELEVATION L: DISTANCE, I: GRADIENT	L: 42.00 m I: 0.48%		L: 12.00 m I: 10.0%		L: 66.00 m I: 0.15%		L: 20.50 m I: 10.73%					
	ORIGINAL GROUND SURFACE ELEVATION	20.20	20.15	20.40	20.20	19.50	19.50	18.50	18.30	17.35		
REDUCED DISTANCE	0.00	23.00	42.00	50.00	61.00	63.00	85.00	105.50	126.00			
DISTANCE	0.00	23.00	17.00	8.00	11.00	12.00	9.50	15.50	25.00	27.00	20.50	
STATION	B.P.	NO. 1	+17.00	NO. 2	+11.00	+13.00	NO. 3	+9.50	NO. 4	+2.00	NO. 5	+22.50
HORIZONTAL ANGLE	IA = 90°00'										IA = 11°19'	

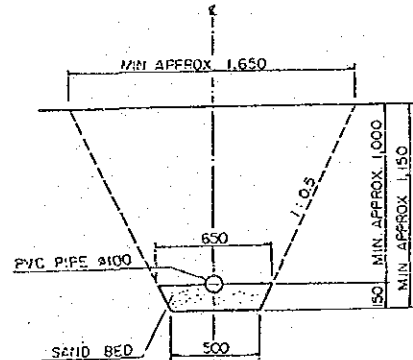

TYPICAL CROSS SECTION

DESIGN DISCHARGE  $Q = 500 \text{ l/min. (0.3 l/sec)}$   
 DESIGN VELOCITY  $v = 1.06 \text{ m/sec}$   
 PIPE CLASS PVC PIPE,  $8 \text{ kg/cm}^2$  (CLASS AZ)  
 PIPE NOMINAL DIAMETER  $\phi 100 \text{ mm}$

DIRECTORATE GENERAL OF FOOD CROP AGRICULTURE  
 THE MODEL INFRASTRUCTURE IMPROVEMENT WORKS FOR  
 THE CENTER FOR DEVELOPMENT OF APPROPRIATE AGRICULTURAL  
 ENGINEERING TECHNOLOGY (ATA-220)

**PIPELINE PROFILE**

JAPAN INTERNATIONAL COOPERATION AGENCY 7

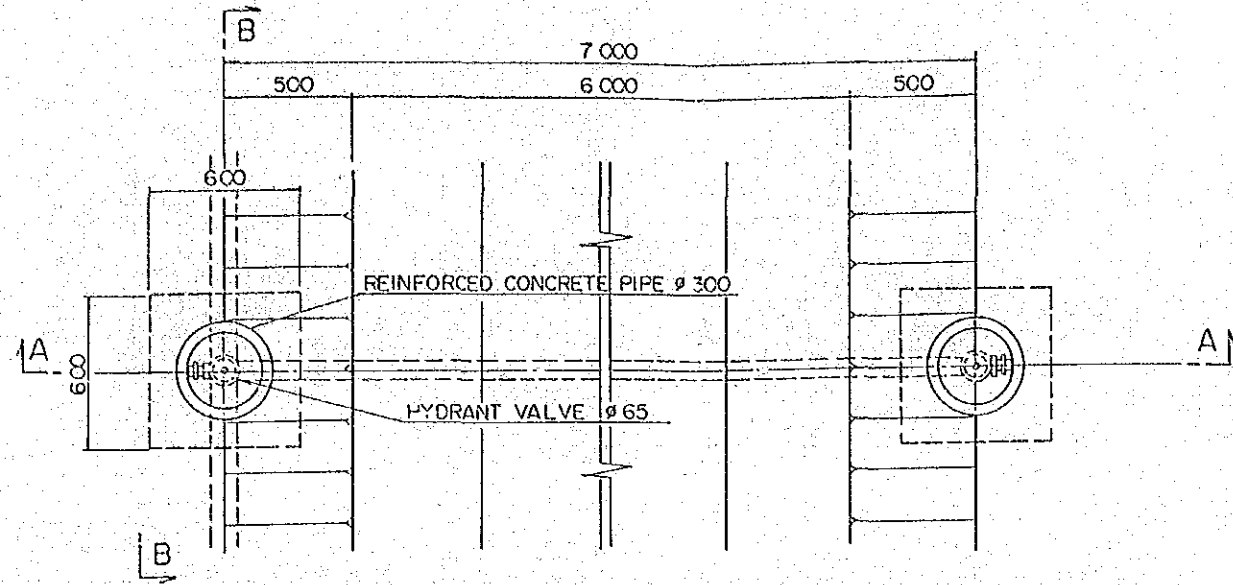

PLAN

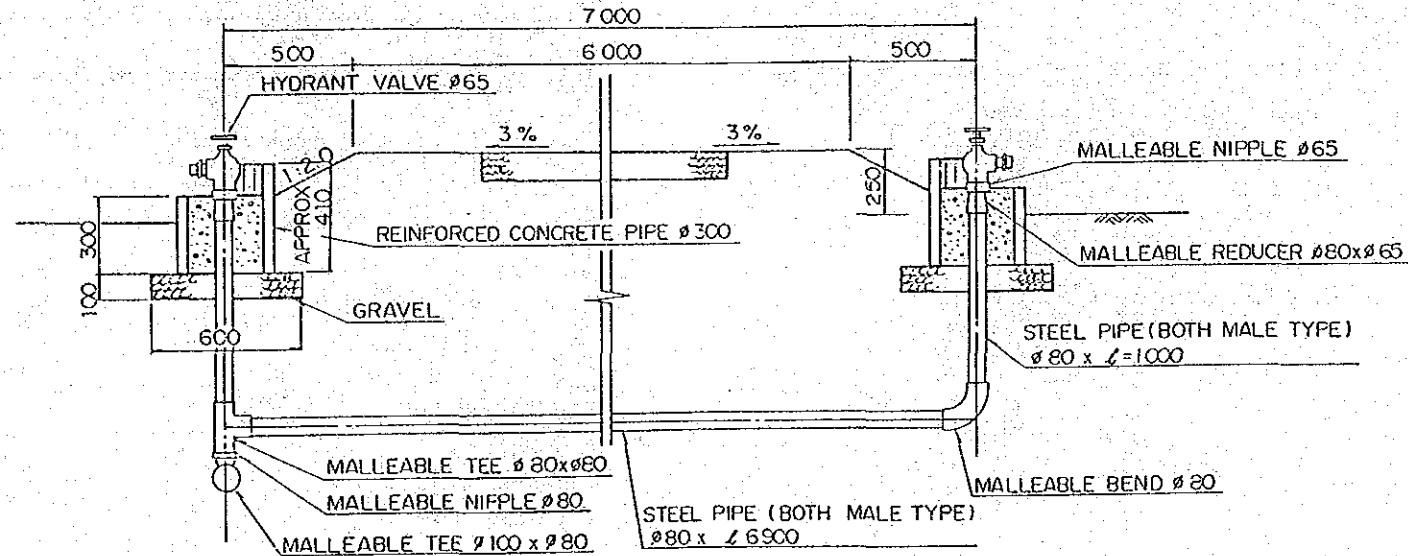

SECTION A - A

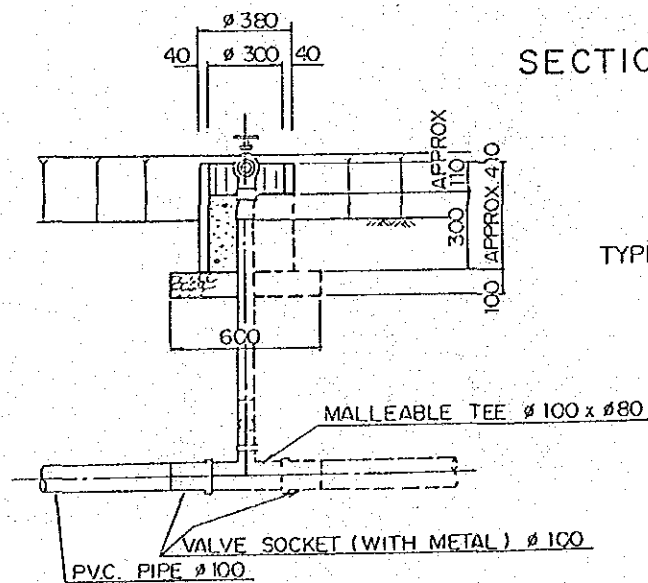

SECTION B - B

TYPICAL HYDRANT BOX FOR GRADIENT FIELD (TYPE A)

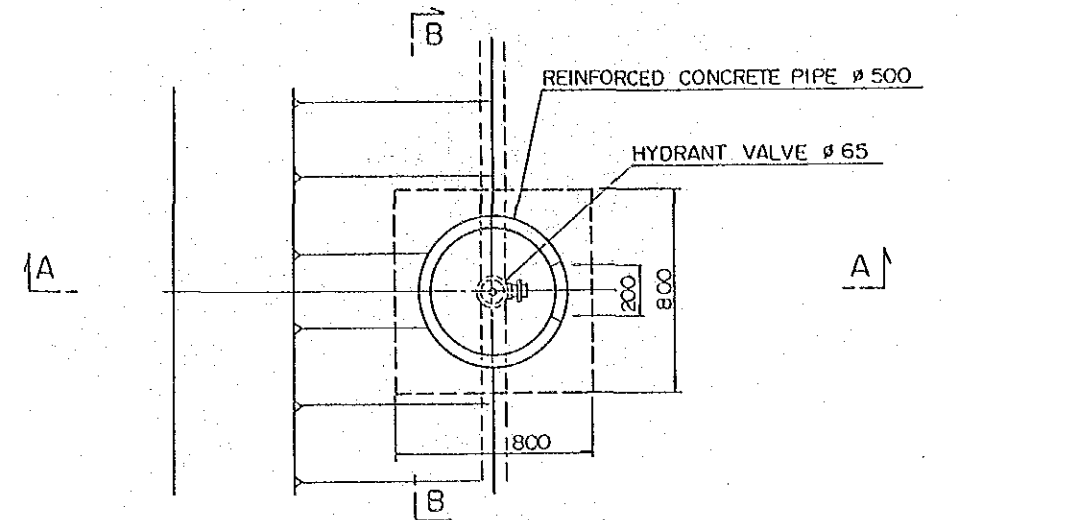

PLAN

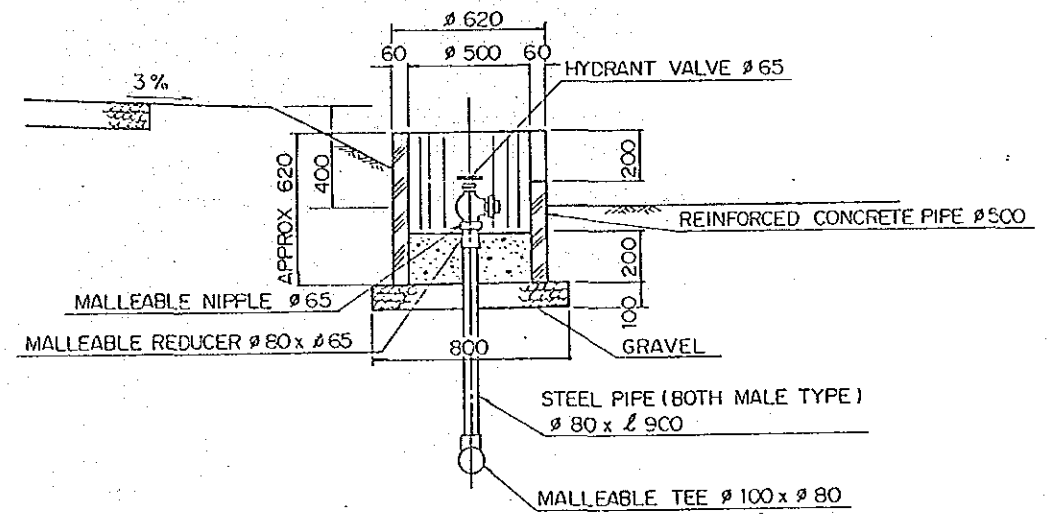

SECTION A - A

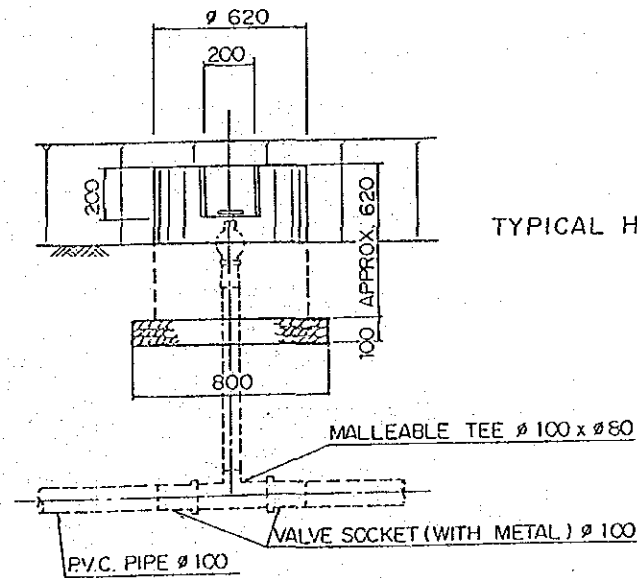

SECTION B - B

TYPICAL HYDRANT BOX FOR LEVELLED FIELD (TYPE B)

DIRECTORATE GENERAL OF FOOD CROP AGRICULTURE  
THE MODEL INFRASTRUCTURE IMPROVEMENT WORKS FOR  
THE CENTER FOR DEVELOPMENT OF APPROPRIATE AGRICULTURAL  
ENGINEERING TECHNOLOGY (ATA-220)

HYDRANT

JAPAN INTERNATIONAL COOPERATION AGENCY DWG. No. 8

DRAINAGE DITCH NO.1

DRAINAGE DITCH NO.2

DRAINAGE DITCH NO.3

DRAINAGE DITCH NO.4

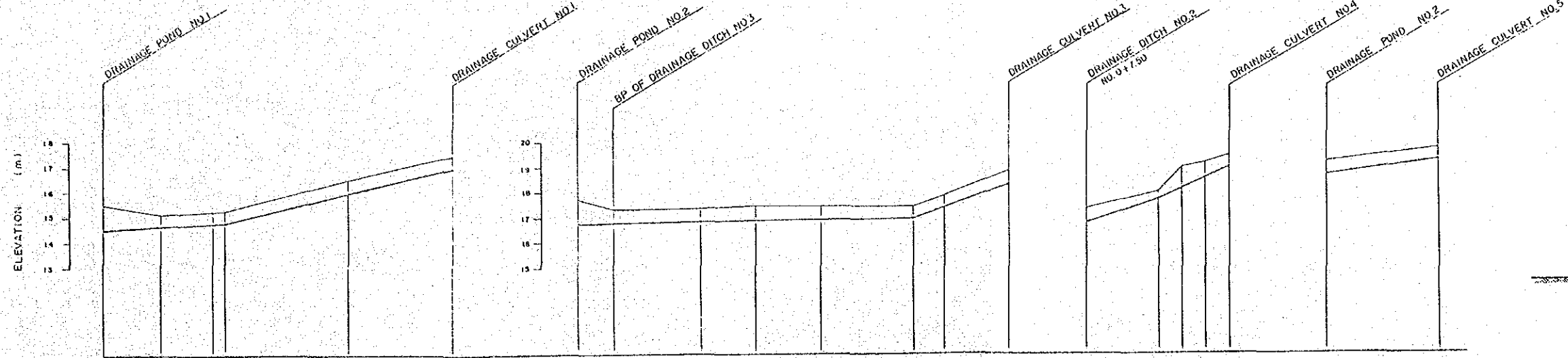

DITCH BOTTOM ELEVATION SLOPE L DISTANCE / GRADIENT	14.50 L: 15.00m 1: 1.00%		14.75 L: 17.00m 1: 1.19%		16.70 L: 58.78m 1: 0.29%		16.50 L: 19.72m 1: 1.10%		16.75 L: 15.00m 1: 0.53%		17.25 L: 15.00m 1: 0.57%		18.00 L: 24.00m 1: 2.50%		18.30	
GROUND SURFACE ELEVATION	15.50	15.10	15.20	15.25	16.50	17.50	17.30	17.40	17.40	17.80	18.50	17.30	18.00	19.20	19.50	19.60
REDUCED DISTANCE	0.00	12.00	22.61	25.00	50.00	72.00	0.00	7.50	17.30	25.00	36.50	50.00	17.40	68.78	75.00	88.50
DISTANCE	0.00	12.00	10.61	2.35	25.00	22.00	0.00	7.50	17.30	11.50	13.50	18.78	6.25	13.50	0.00	0.00
STATION	B.P.	+2.00	+22.61	NO.1	NO.2	+22.00	B.F.	+7.50	NO.1	+11.50	NO.2	+18.78	NO.3	+13.50	B.P.	+15.00
HORIZONTAL ANGLE	IA+45-00-00				IA+43-36-10				IA+27-24-49				IA+73-48-39			

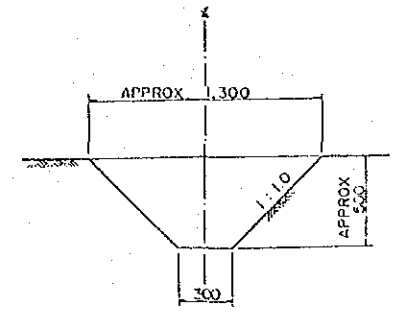

TYPICAL CROSS SECTION

DRAINAGE DITCH NO.5

DRAINAGE DITCH NO.6

DRAINAGE DITCH NO.7

DRAINAGE DITCH NO.8

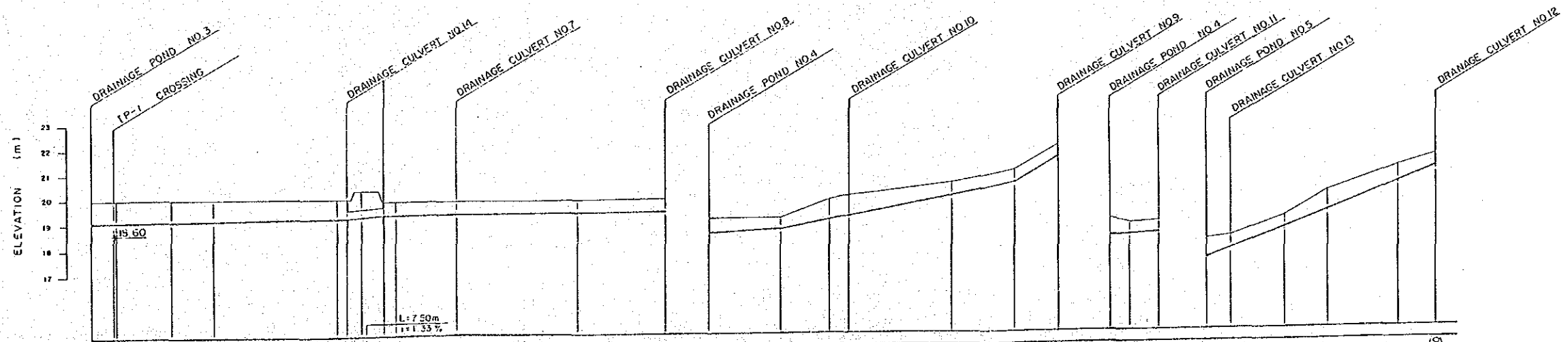

DITCH BOTTOM ELEVATION SLOPE L DISTANCE / GRADIENT	19.10 L: 52.00m 1: 0.19%		19.20 L: 7.50m 1: 1.33%		19.50 L: 59.50m 1: 0.17%		18.50 L: 15.00m 1: 0.67%		18.50 L: 48.00m 1: 3.96%		18.30 L: 15.00m 1: 1.17%		18.30 L: 15.00m 1: 1.00%		18.30 L: 48.00m 1: 7.50%		20.30		
GROUND SURFACE ELEVATION	20.00	20.00	20.00	20.00	19.92	19.95	20.30	20.30	19.85	19.10	19.80	20.00	20.00	19.00	18.80	18.20	20.00	21.40	
REDUCED DISTANCE	0.00	4.50	16.50	25.00	25.00	32.50	55.00	59.50	62.00	75.00	100.00	118.00	118.00	0.00	15.00	25.00	29.00	20.00	
DISTANCE	0.00	4.50	16.50	8.50	25.00	3.00	4.50	2.50	82.00	13.00	25.00	25.00	4.00	6.00	10.00	0.00	5.00	23.00	
STATION	B.P.	+1.50	+16.50	NO.1	NO.2	+12.00	+5.00	+9.50	+12.00	NO.3	NO.4	+18.00	B.P.	+15.00	NO.1	+4.00	+10.00	B.P.	+5.00
HORIZONTAL ANGLE	IA+29-35-31				IA+30-00-00				IA+90-00-00				IA+30-00-00						

DIRECTOR GENERAL OF FOOD CROP AGRICULTURE  
THE MODEL INFRASTRUCTURE IMPROVEMENT WORKS FOR  
THE CENTER FOR DEVELOPMENT OF APPROPRIATE AGRICULTURAL  
ENGINEERING TECHNOLOGY (ATA-220)

DRAINAGE DITCH

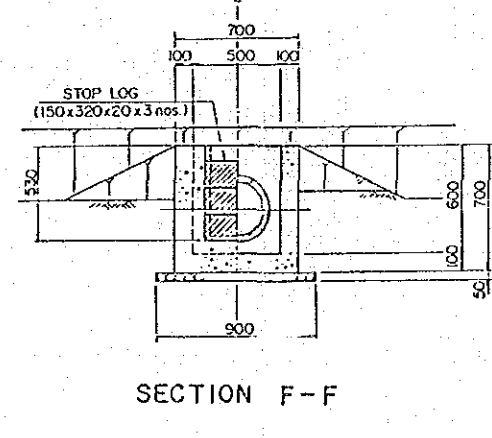
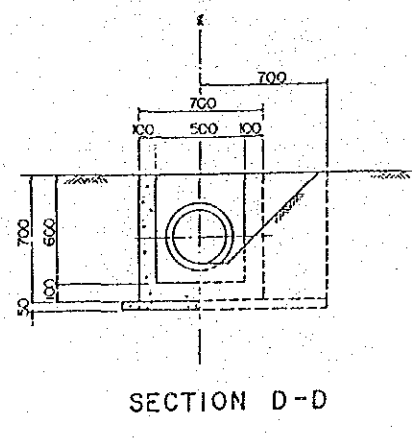
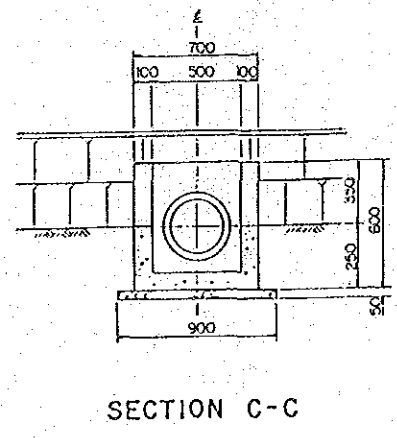
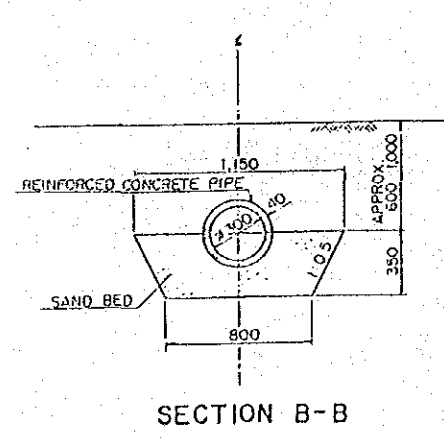
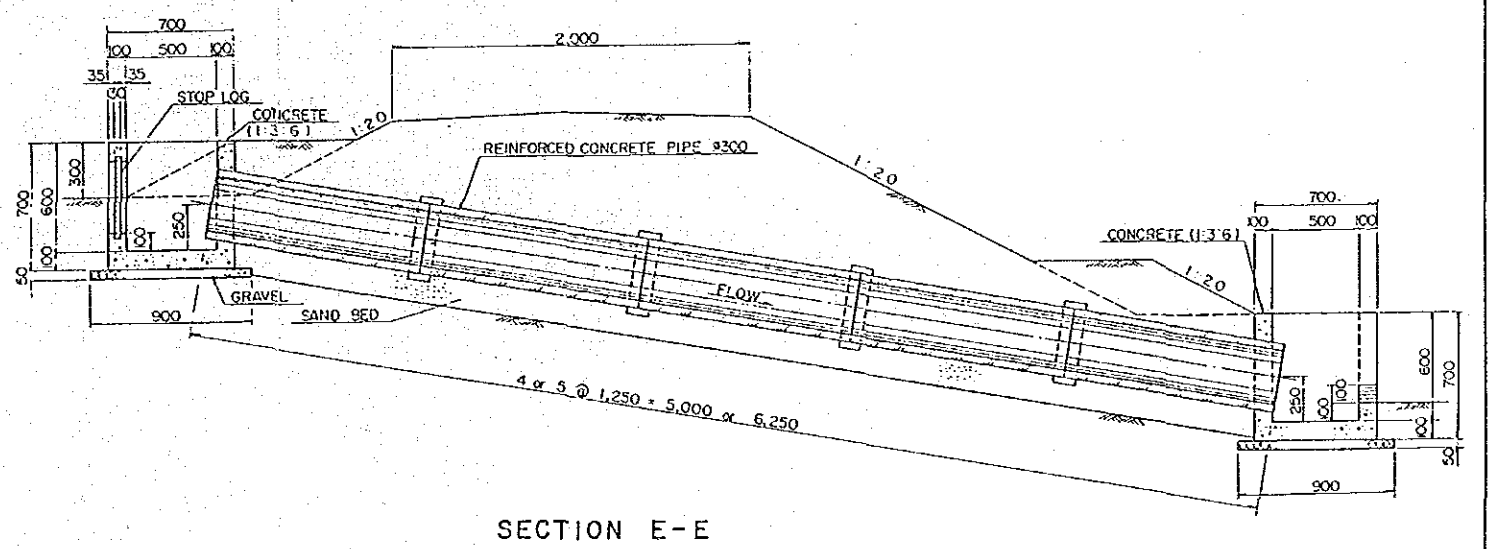
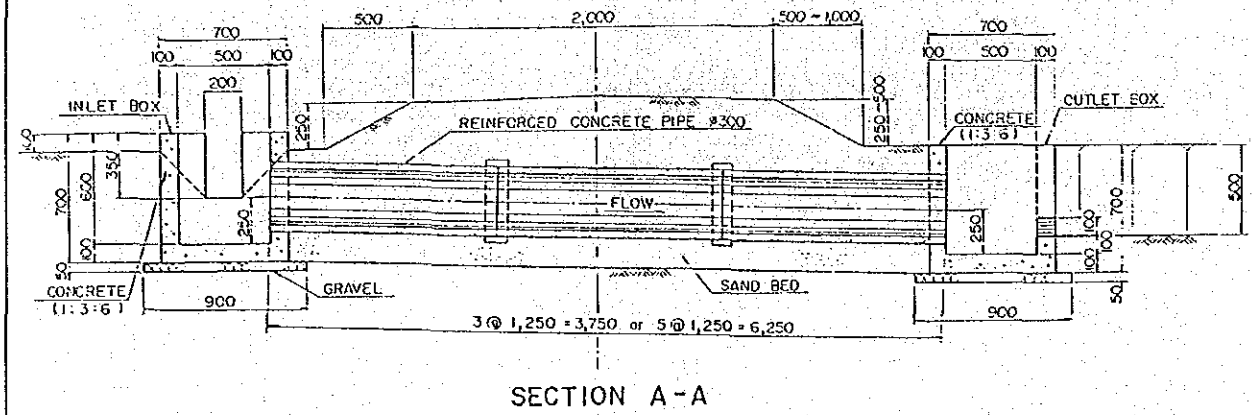
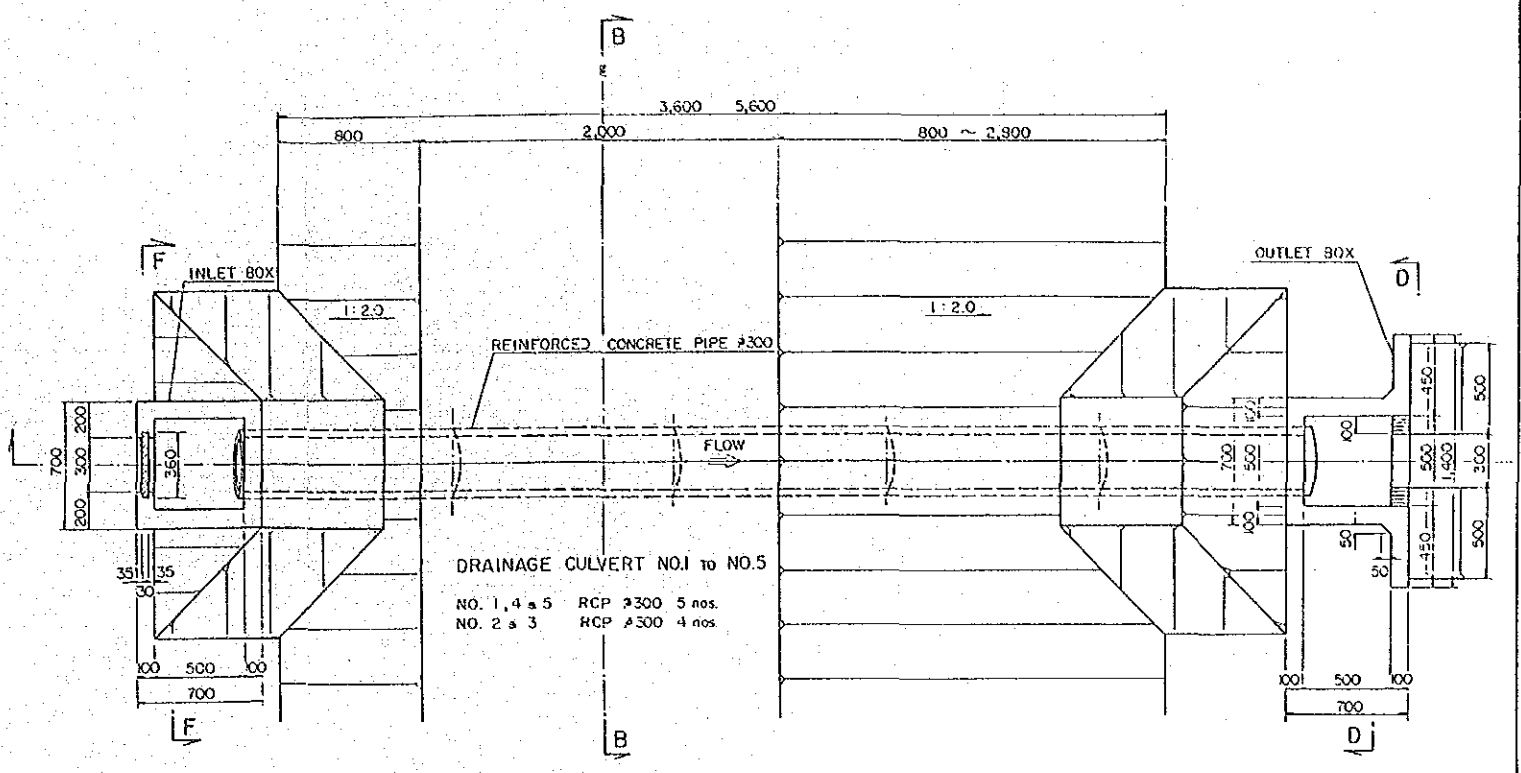
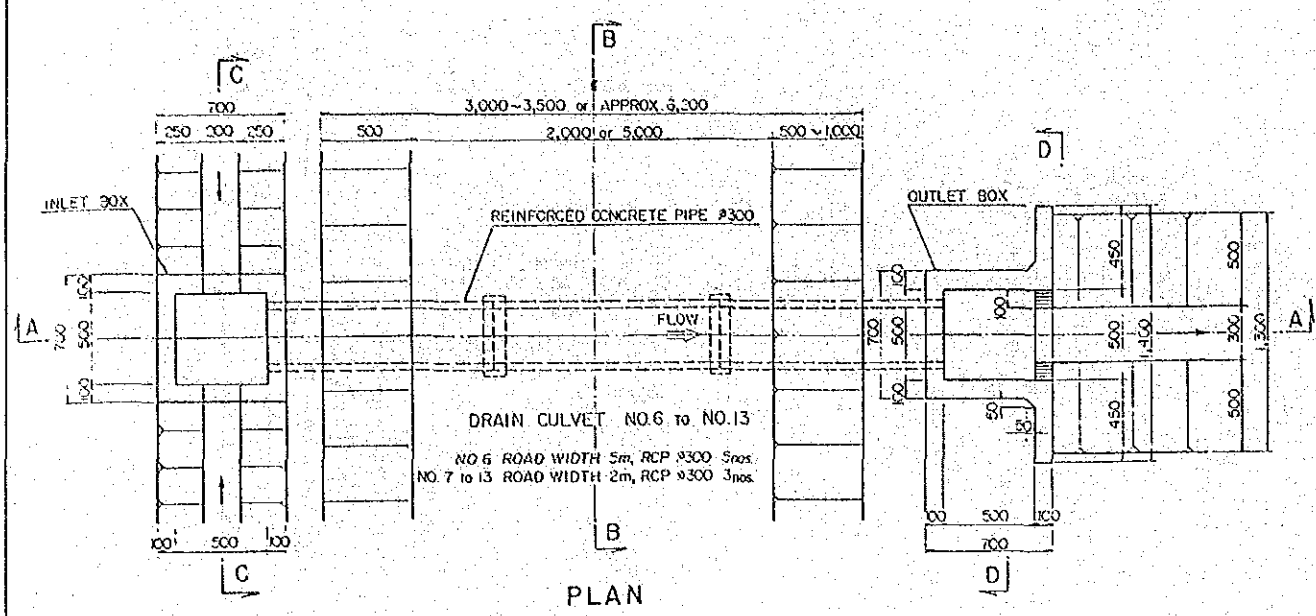

DIRECTORATE GENERAL OF FOOD CROP AGRICULTURE  
 THE MODEL INFRASTRUCTURE IMPROVEMENT WORKS FOR  
 THE CENTER FOR DEVELOPMENT OF APPROPRIATE AGRICULTURAL  
 ENGINEERING TECHNOLOGY (ATA-220)

**DRAINAGE CULVERT (1/2)**

JAPAN INTERNATIONAL COOPERATION AGENCY DWG. NO. 10

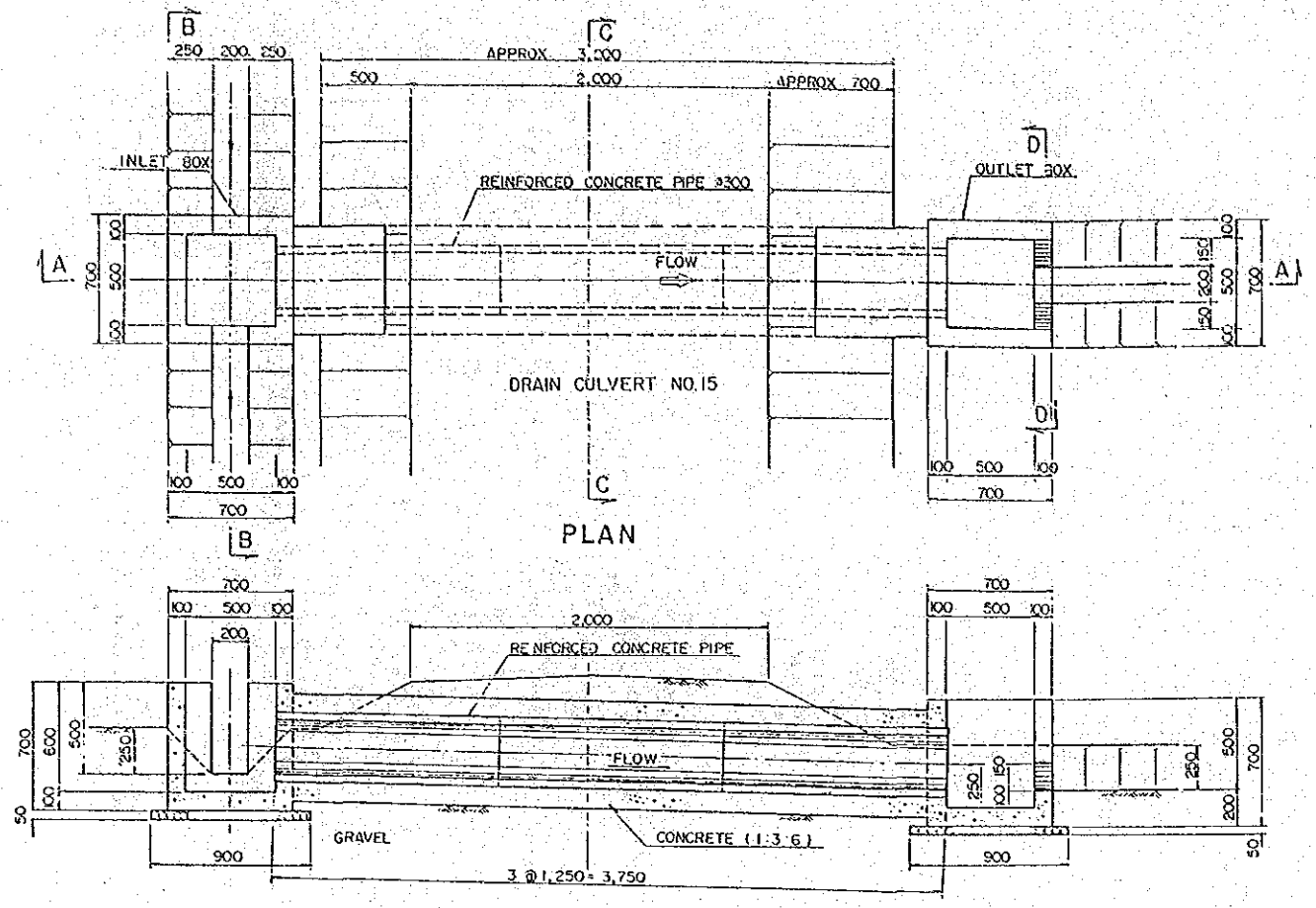

PLAN

SECTION A-A

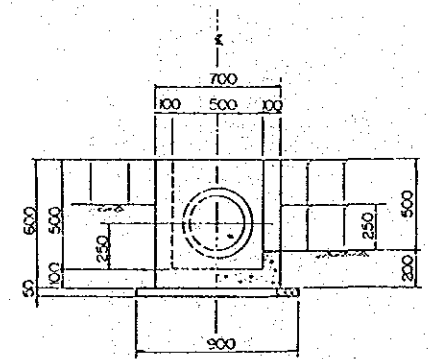

SECTION B-B

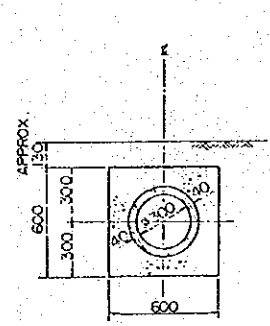

SECTION C-C

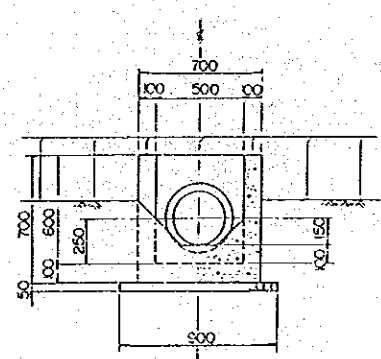

SECTION D-D

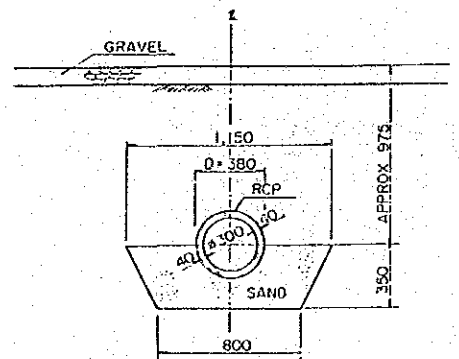

SECTION F-F

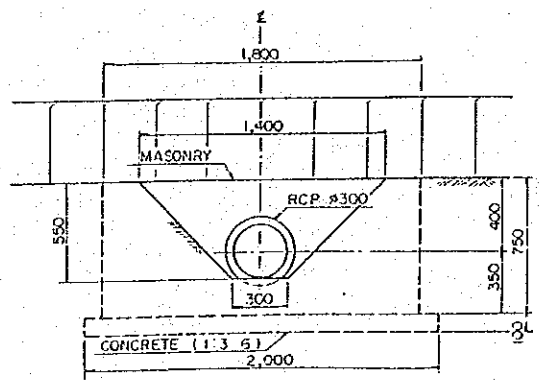

SECTION G-G

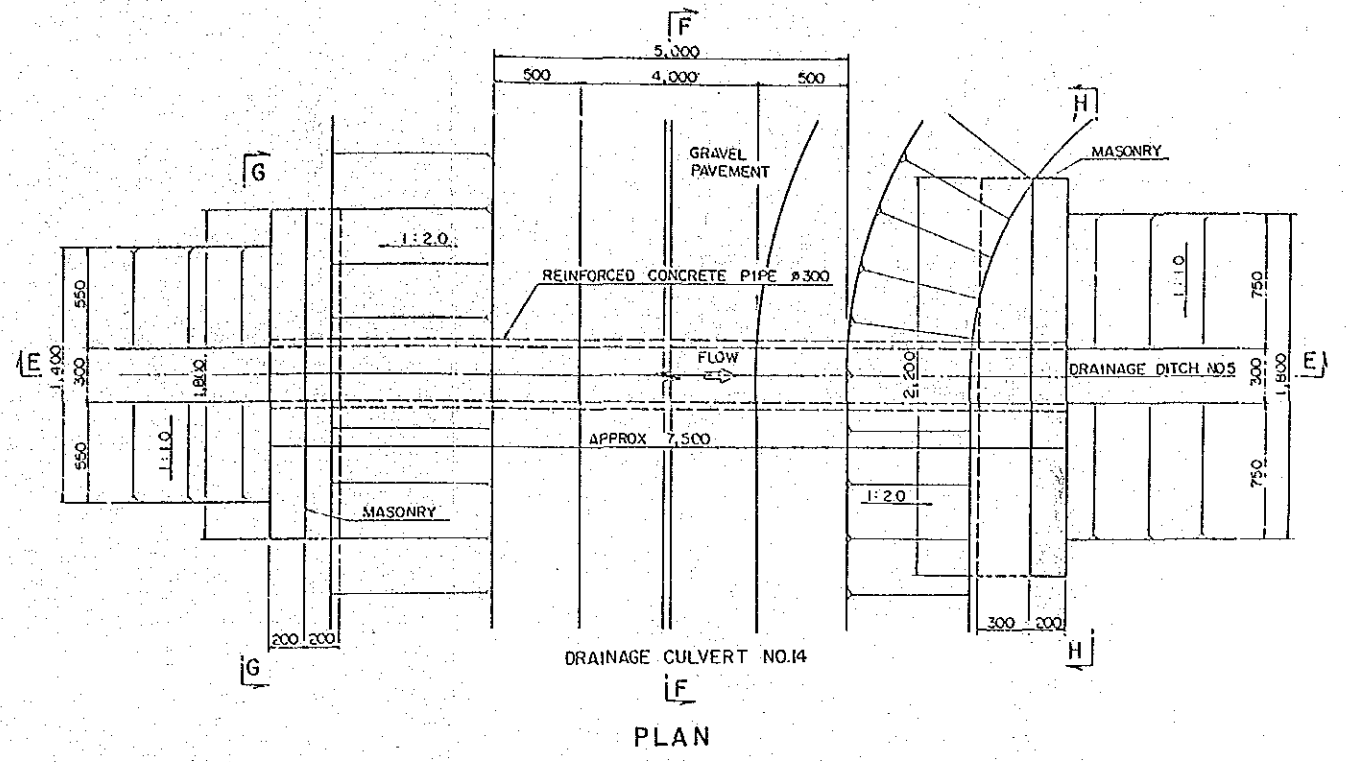

PLAN

SECTION E-E

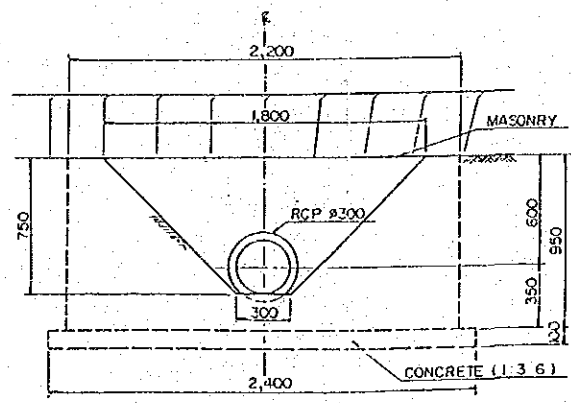

SECTION H-H

DIRECTORATE GENERAL OF FOOD CROP AGRICULTURE  
 THE MODEL INFRASTRUCTURE IMPROVEMENT WORKS FOR  
 THE CENTER FOR DEVELOPMENT OF APPROPRIATE AGRICULTURAL  
 ENGINEERING TECHNOLOGY (ATA-320)

**DRAINAGE CULVERT (2/2)**

JAPAN INTERNATIONAL COOPERATION AGENCY / DMG / 11



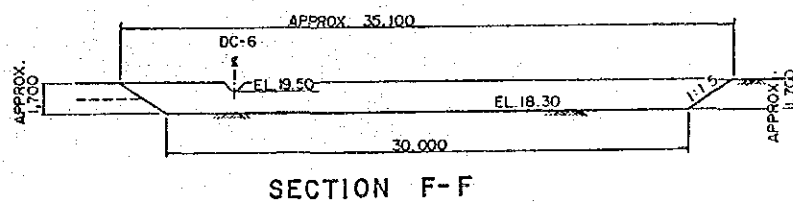
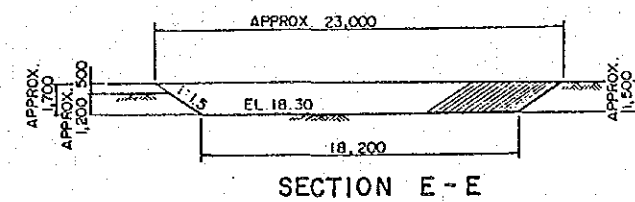
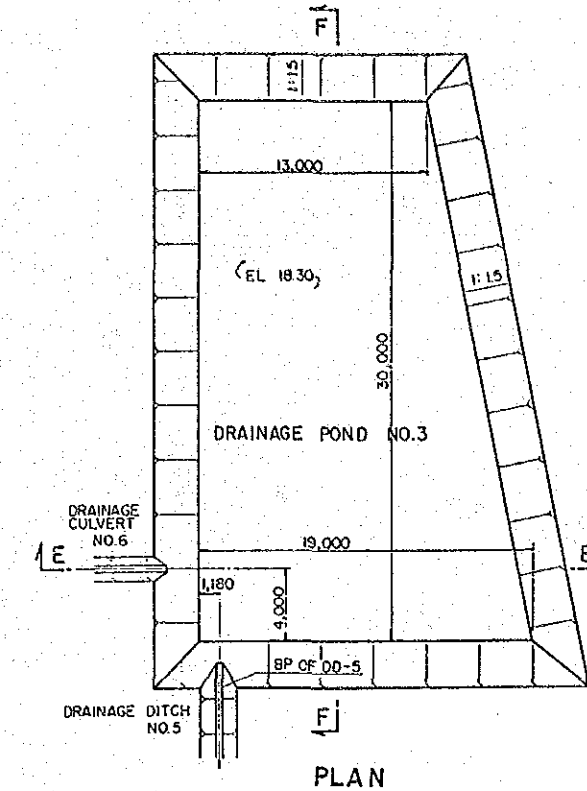
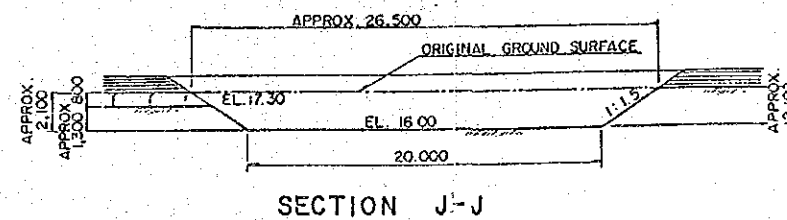
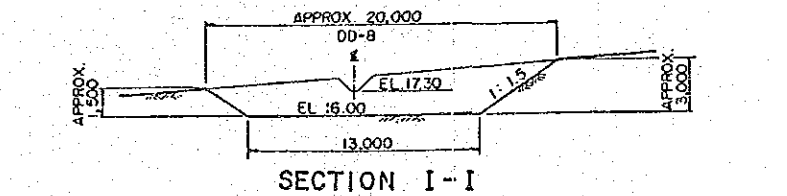
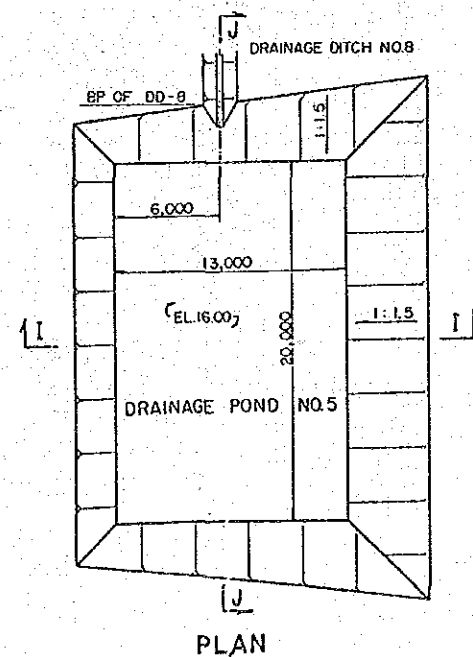
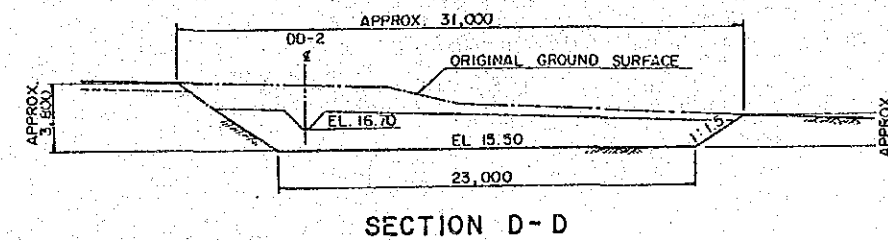
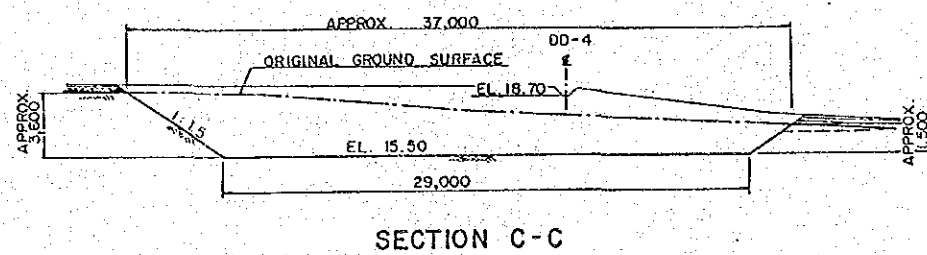
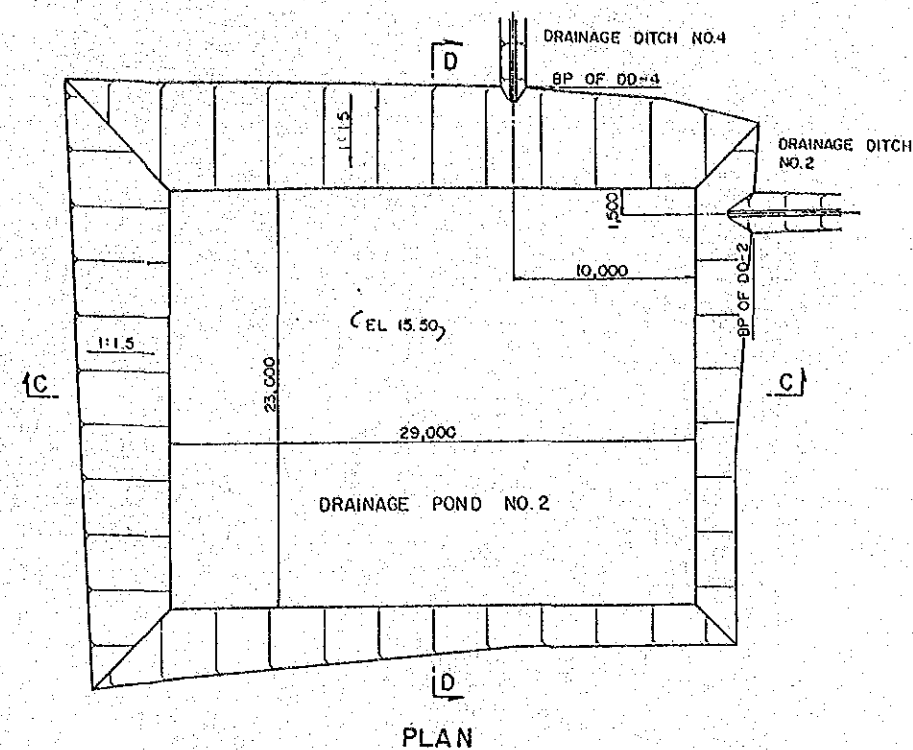
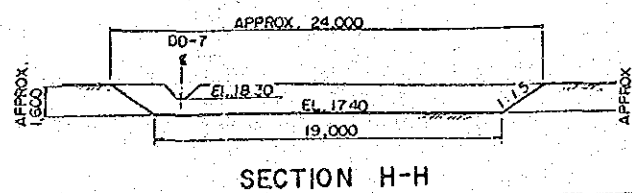
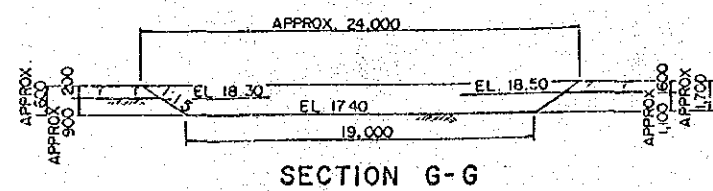
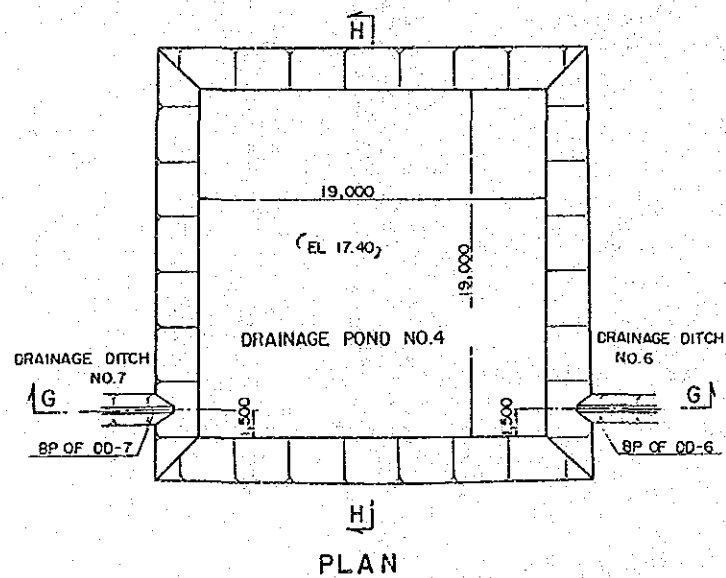
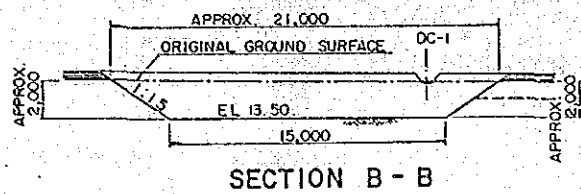
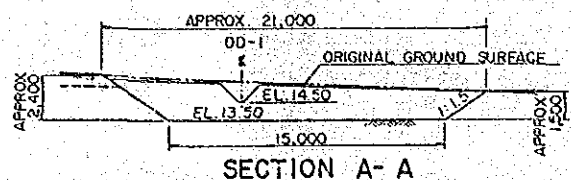
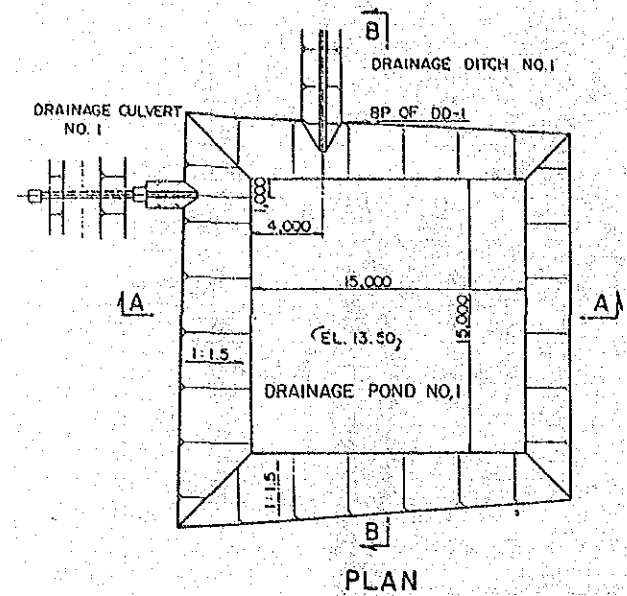

DIRECTORATE GENERAL OF FOOD CROP AGRICULTURE  
THE MODEL INFRASTRUCTURE IMPROVEMENT WORKS FOR  
THE CENTER FOR DEVELOPMENT OF APPROPRIATE AGRICULTURAL  
ENGINEERING TECHNOLOGY (ATA-220)

**DRAINAGE POND**

JAPAN INTERNATIONAL COOPERATION AGENCY  
110 12

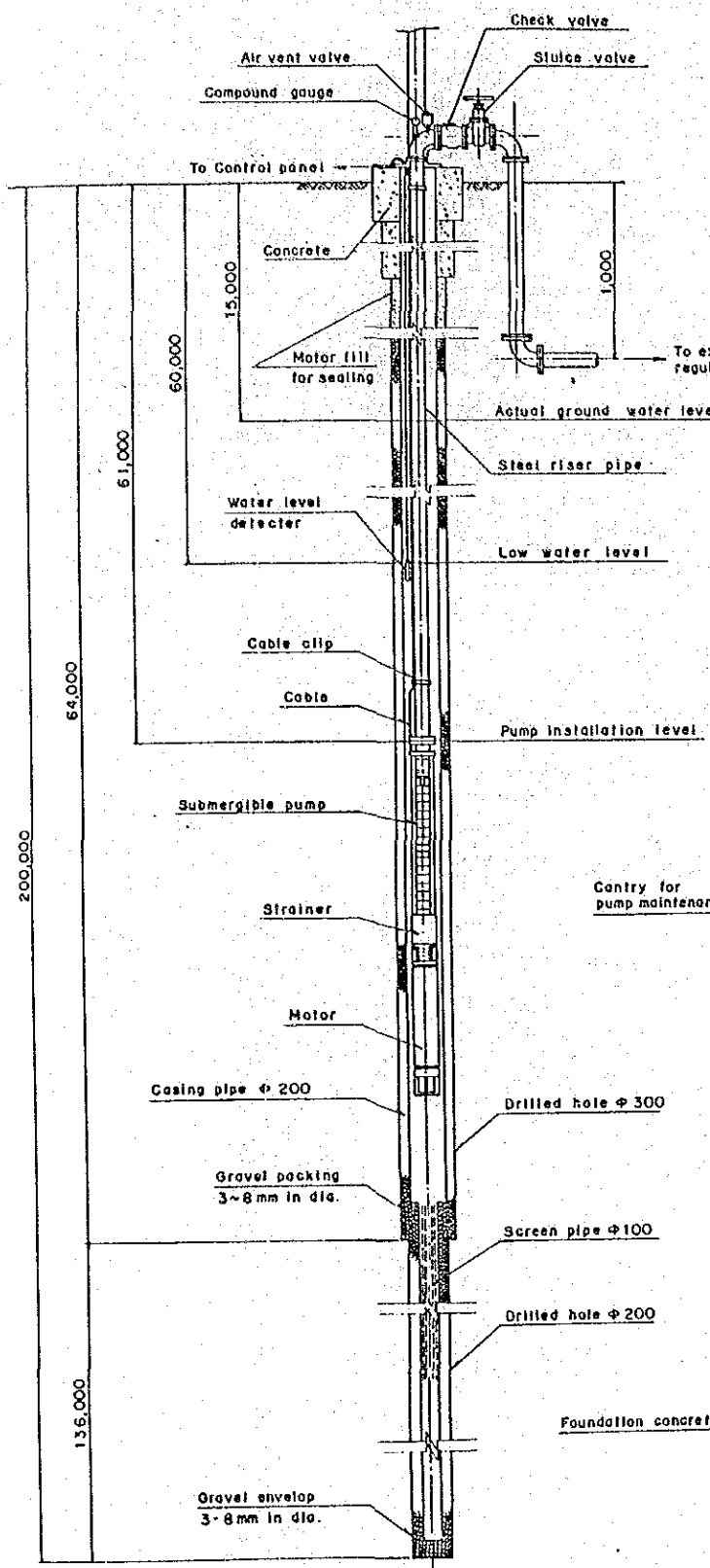

SECTION A-A  
SCALE A

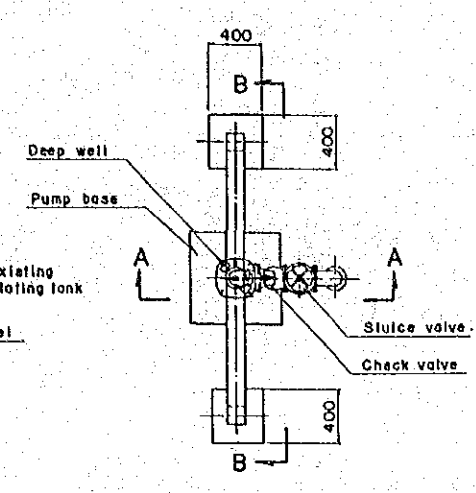

PLAN OF SUBMERGIBLE PUMP  
SCALE A

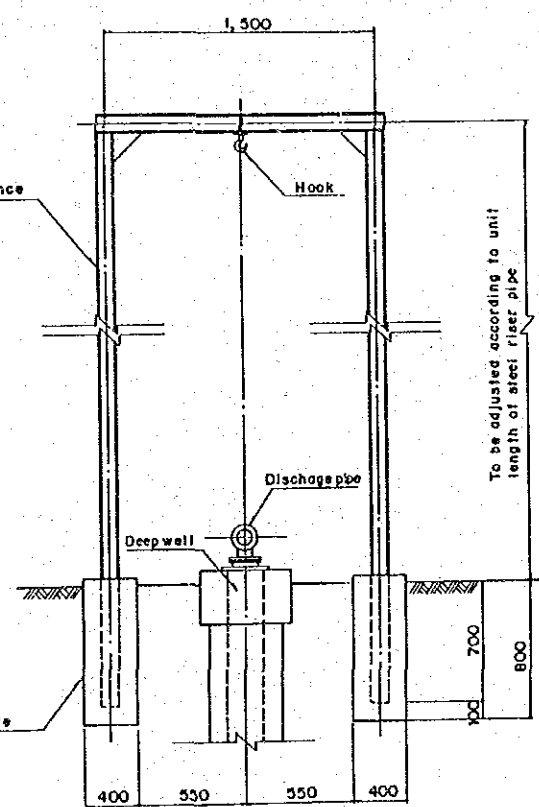

SECTION B-B  
SCALE A

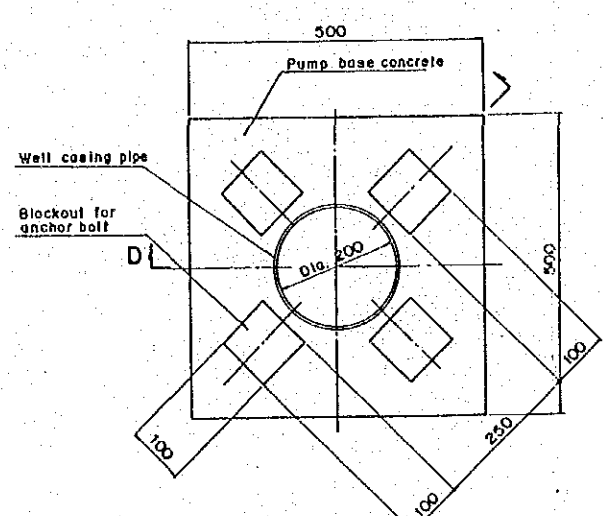

PLAN OF PUMP BASE  
SCALE B

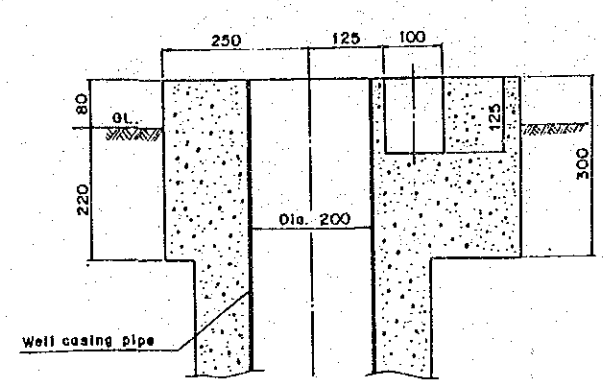

SECTION D-D  
SCALE B

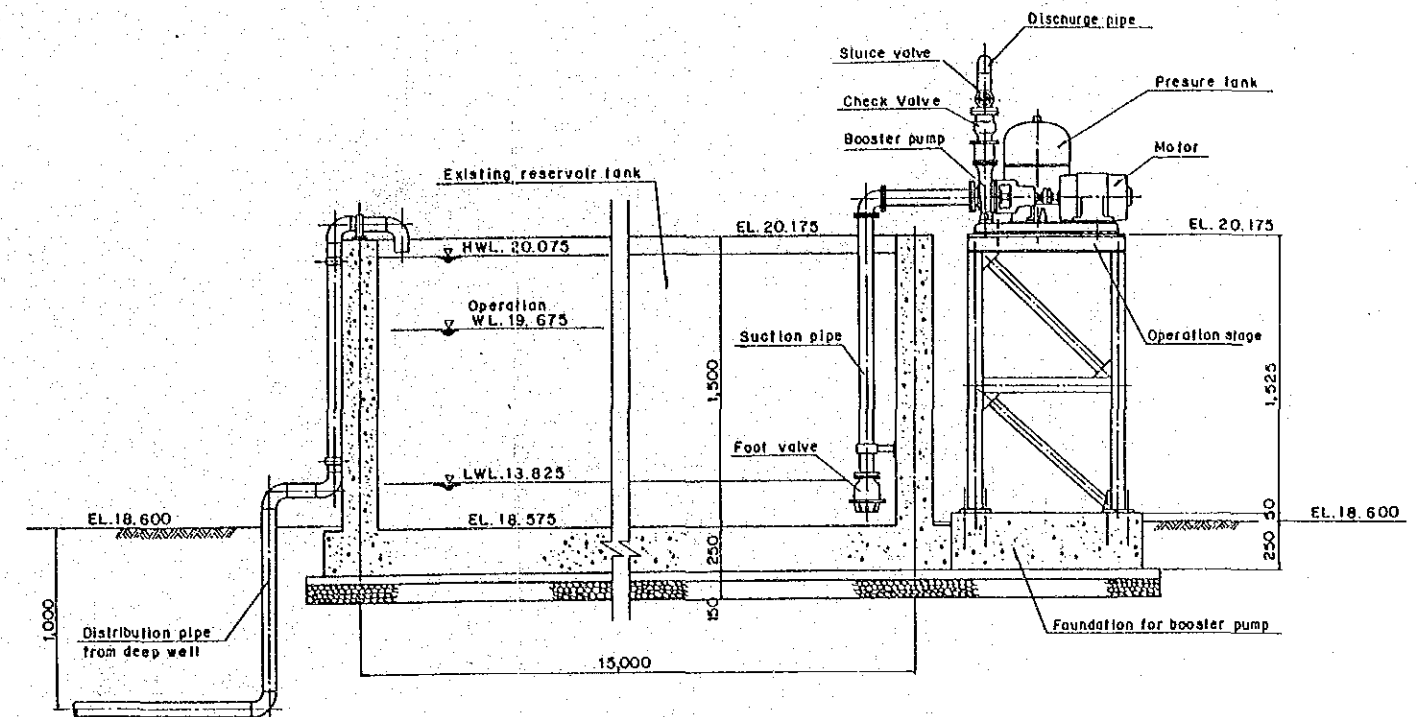

VIEW C-C  
SCALE C

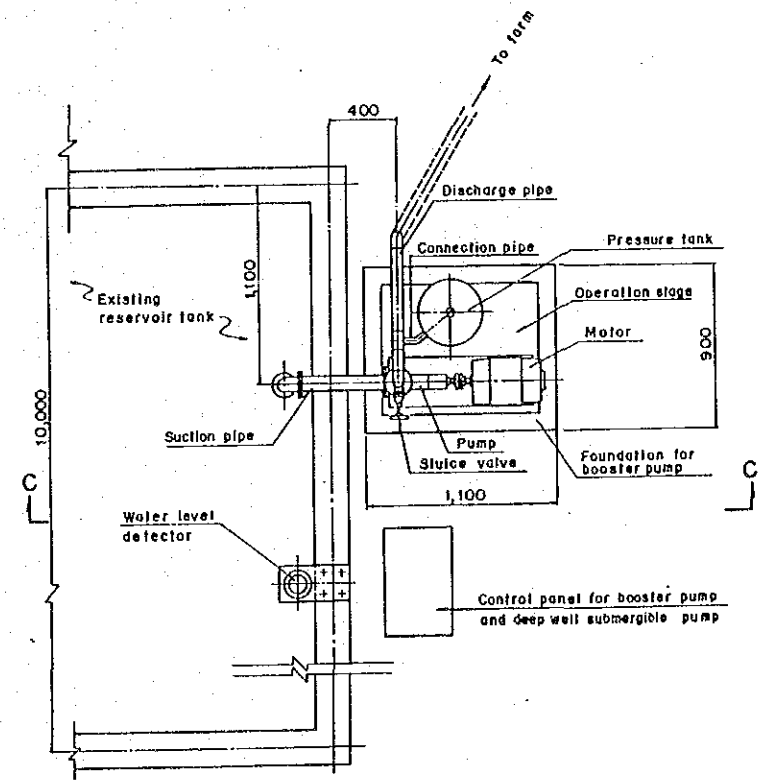

PLAN OF BOOSTER PUMP  
SCALE A

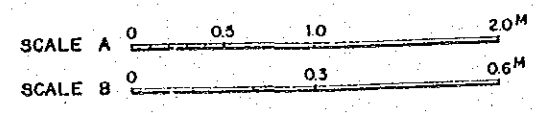

DIRECTORATE GENERAL OF FOOD CROP AGRICULTURE  
THE MODEL INFRASTRUCTURE IMPROVEMENT WORKS FOR  
THE CENTER FOR DEVELOPMENT OF APPROPRIATE AGRICULTURAL  
ENGINEERING TECHNOLOGY (ATA - 220)

**DEEP WELL & PUMPS**

JAPAN INTERNATIONAL COOPERATION AGENCY DWG. NO. 13



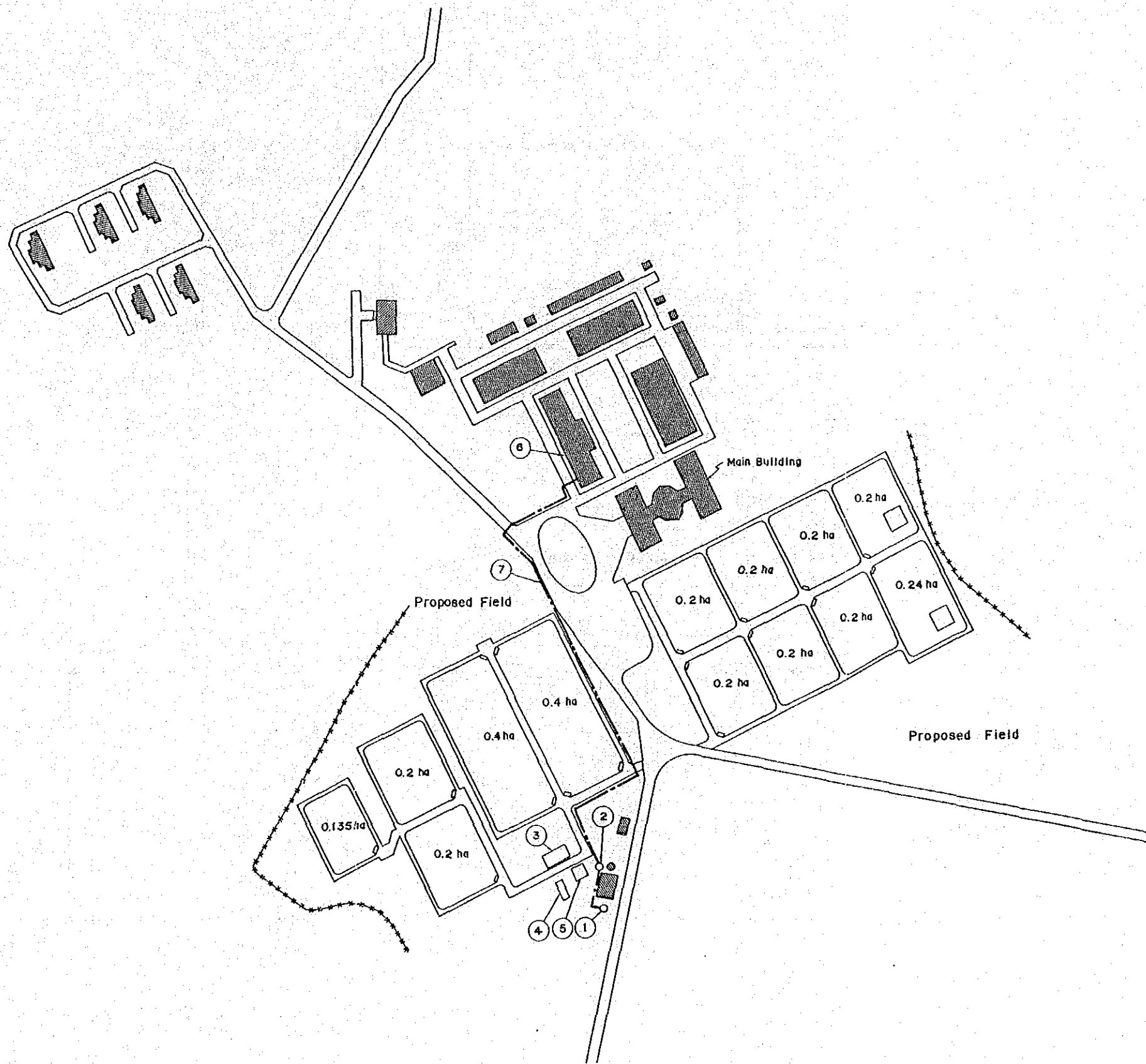

**LEGEND**

- \*\*\*\*\* Fence (Boundary of the Center)
- Existing Structures
- ① Proposed Deep Well & Pump
- ② Proposed Booster Pump
- ③ Proposed Warehouse
- ④ Proposed Water Tightness Test Pit
- ⑤ Proposed Carwash
- ⑥ Laboratory and Testing
- ⑦ Proposed Route of Underground Power Cable

DIRECTORATE GENERAL OF FOOD CROP AGRICULTURE  
 THE MODEL INFRASTRUCTURE IMPROVEMENT WORKS FOR  
 THE CENTER FOR DEVELOPMENT OF APPROPRIATE AGRICULTURAL  
 ENGINEERING TECHNOLOGY (ATA - 220)

**ROUTE OF POWER CABLE  
(1/3)**

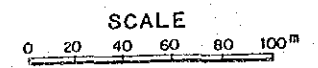

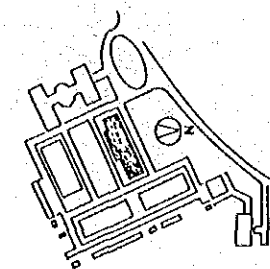
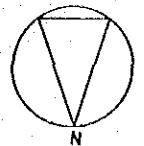

KEY PLAN

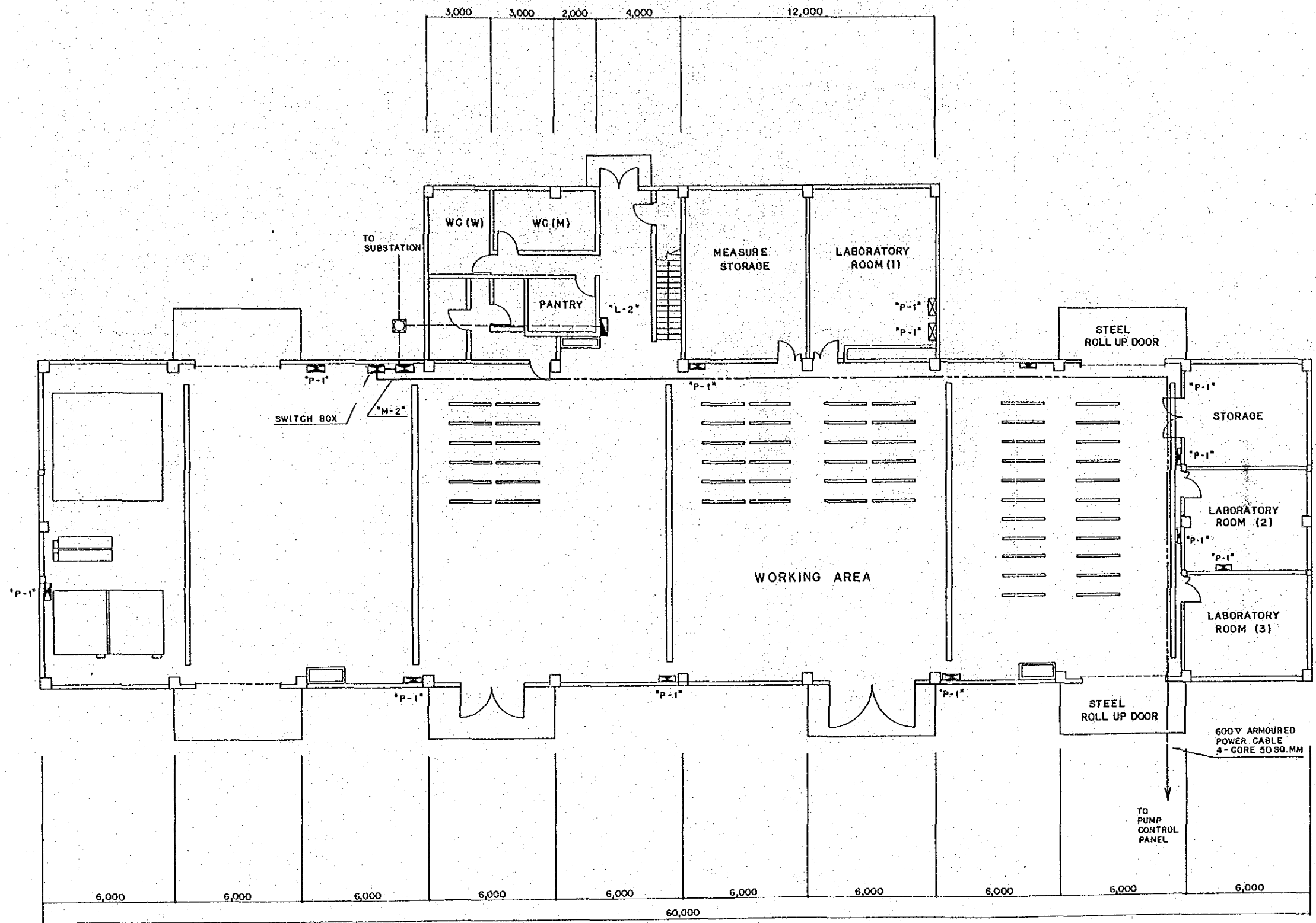

FIRST FLOOR PLAN

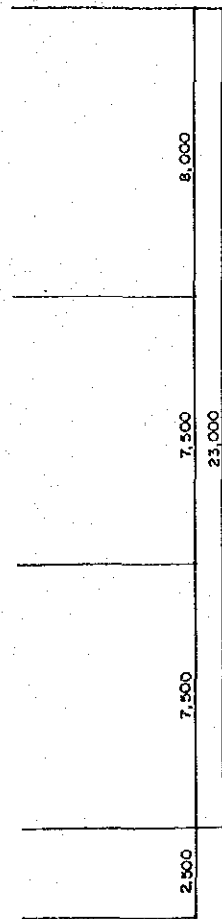

- NOTES
- 1) IN LABORATORY & TESTING, 600V XLPE ARMoured POWER CABLE SHALL BE LAID WITH STEEL PIPE ALONG WITH THE EXISTING CABLE.
  - 2) AT OUTSIDE, THE CABLE SHALL BE BURIED ACCORDING TO RELEVANT DRAWING.

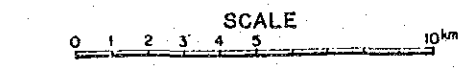

DIRECTORATE GENERAL OF FOOD CROP AGRICULTURE  
 THE MODEL INFRASTRUCTURE IMPROVEMENT WORKS FOR  
 THE CENTER FOR DEVELOPMENT OF APPROPRIATE AGRICULTURAL  
 ENGINEERING TECHNOLOGY (ATA - 220)

**ROUTE OF POWER CABLE  
 (2/3)**

JAPAN INTERNATIONAL COOPERATION AGENCY | DWO. NO. 15

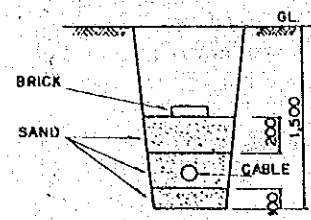

SECTION A

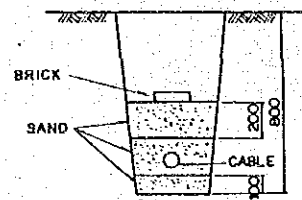

SECTION B

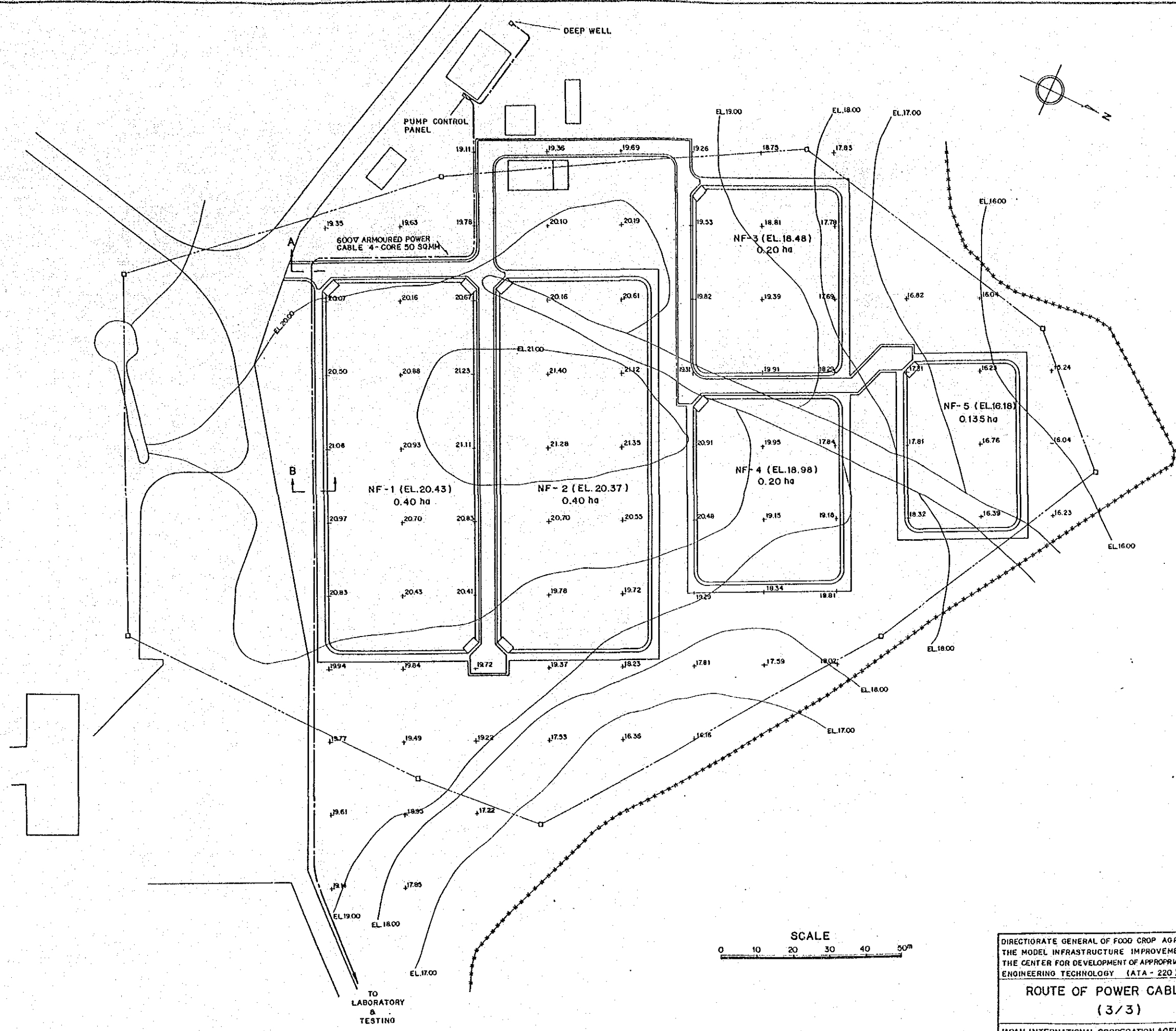

TO  
LABORATORY  
&  
TESTING

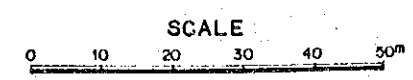

DIRECTORATE GENERAL OF FOOD CROP AGRICULTURE  
THE MODEL INFRASTRUCTURE IMPROVEMENT WORKS FOR  
THE CENTER FOR DEVELOPMENT OF APPROPRIATE AGRICULTURAL  
ENGINEERING TECHNOLOGY (ATA - 220)

**ROUTE OF POWER CABLE  
(3/3)**

JAPAN INTERNATIONAL COOPERATION AGENCY DWG. NO. 18



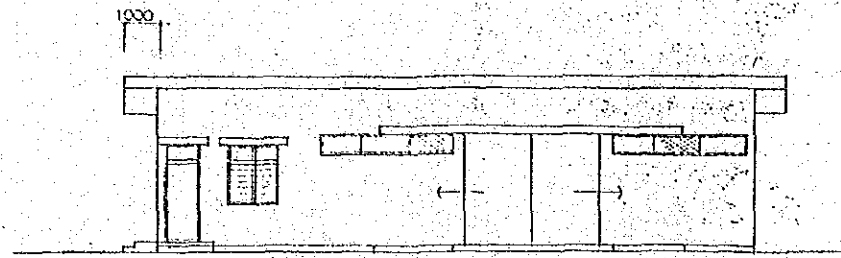

FRONT ELEVATION

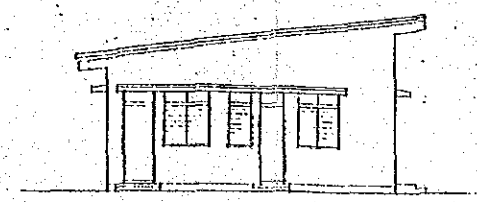

SIDE ELEVATION

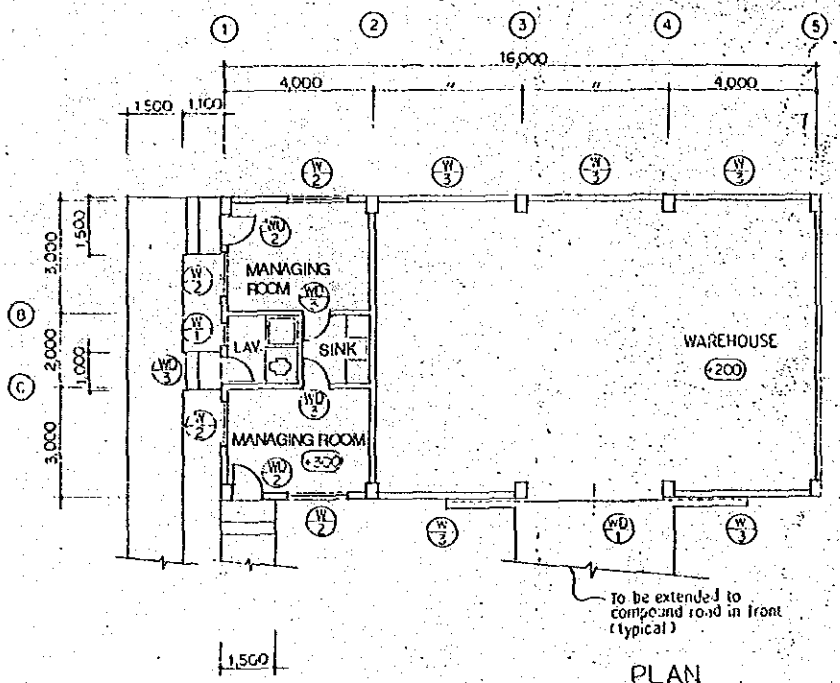

PLAN

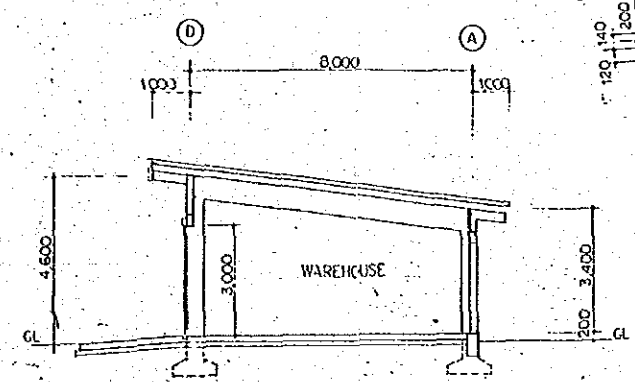
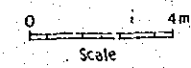

SECTION

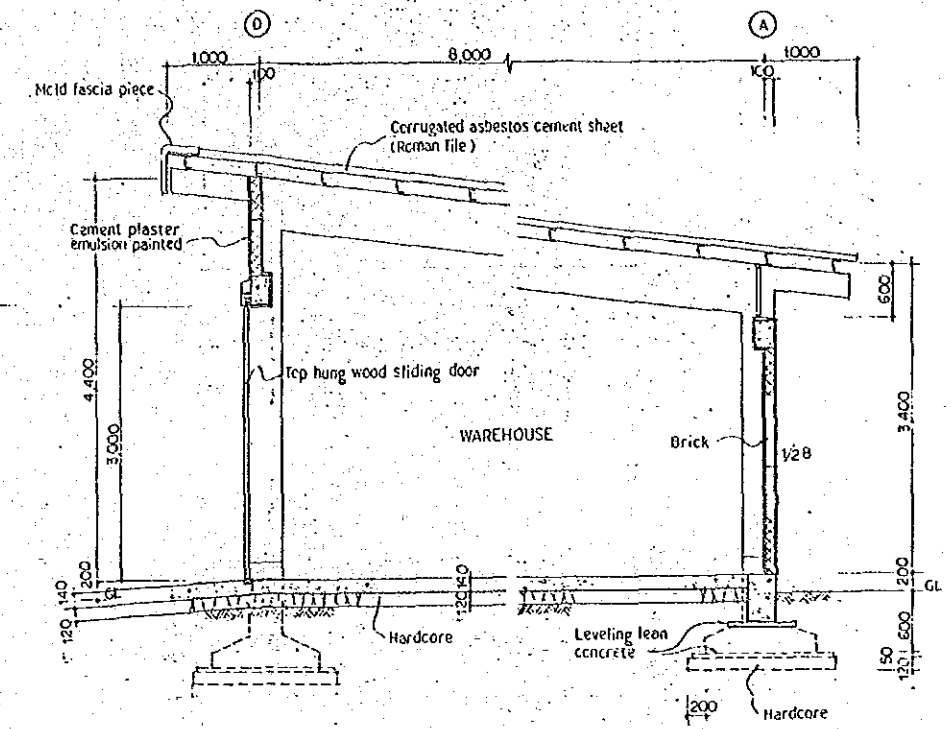

SECTION DETAIL

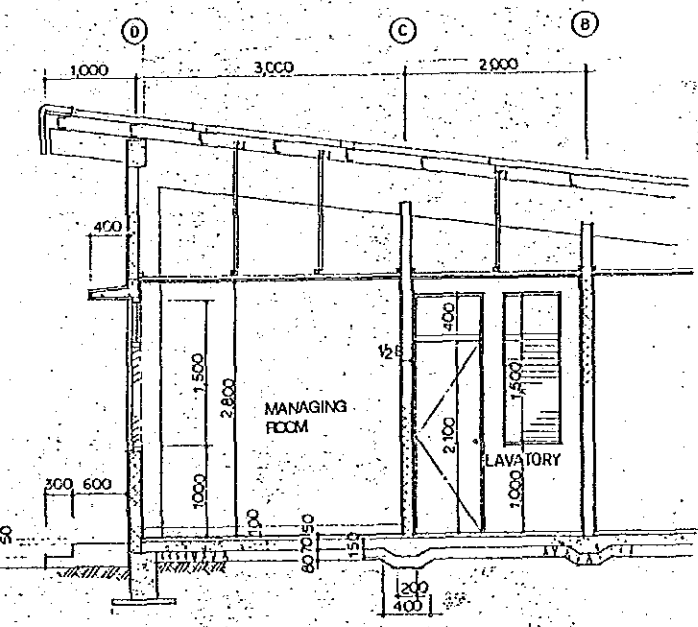

SECTION DETAIL

INTERIOR FINISHES

	FLOOR	BASE	WALL	CEILING
MANAGING ROOM	Concrete metal troweled	Cement plaster	Cement plaster	Roof structure exposed
OFFICE	Cement tile	Cement plaster, painted	Cement plaster, painted	Plywood 5mm thick, painted
LAVATORY	Cement screed		Do.	Do.
SINK	Cement tile	Cement plaster, painted	Do.	Do.

DOOR & WINDOW

WD 1	WD 2	WD 3	W 1	W 2	W 3
Top-hung wood sliding door, top & bottom tracks & wheels, door stops, door handles, pad lock, oil painted.	Wood swing door w/ glazed transom, door closer, lever handle, cylinder lock, oil painted.	Wood swing door w/ glazed transom, lever handle, door stop, oil painted, lavatory latch to LAVATORY.	Jalousie window w/ fixed transom in steel frame, oil painted.	Same as W-1	Steel grille w/ expanded metal, oil painted.

DIRECTORATE GENERAL OF FOOD CROP AGRICULTURE  
 THE MODEL INFRASTRUCTURE IMPROVEMENT WORKS FOR  
 THE CENTER FOR DEVELOPMENT OF APPROPRIATE AGRICULTURAL  
 ENGINEERING TECHNOLOGY (ATA - 220)

WAREHOUSE

JAPAN INTERNATIONAL COOPERATION AGENCY DWG NO. 18

WAREHOUSE

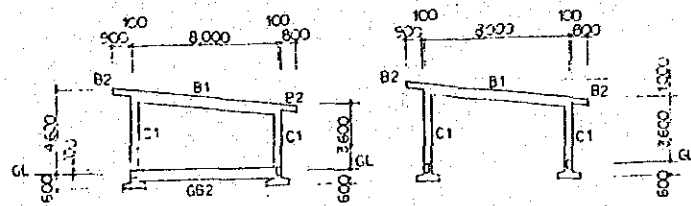
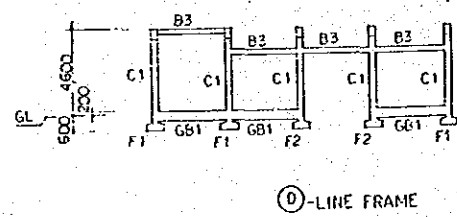
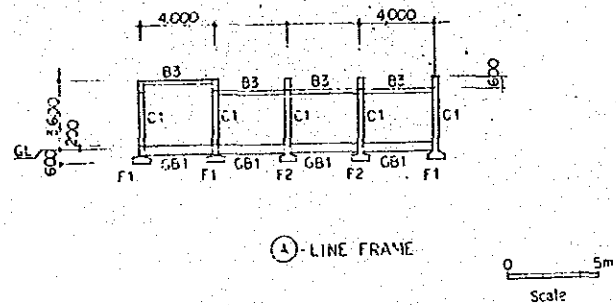
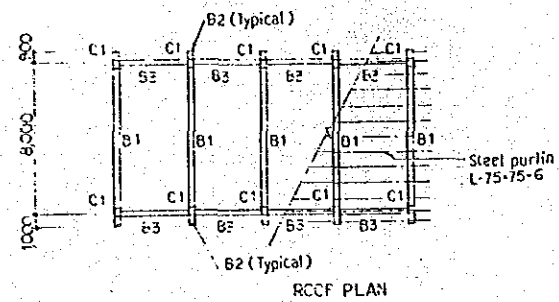
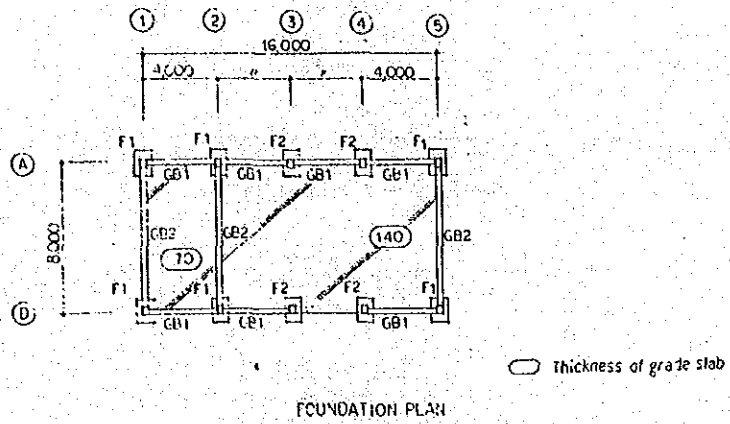

B1		B2	B3	GRADE SLAB (140)
END	CENTER	END & TIP	END & CENTER	GRADE SLAB (70)
				Reinforcing not needed
GB1		GB2		CANOPY
END	CENTER	END	CENTER	
C1	F1 (F2)			
TOP & BOTTOM				

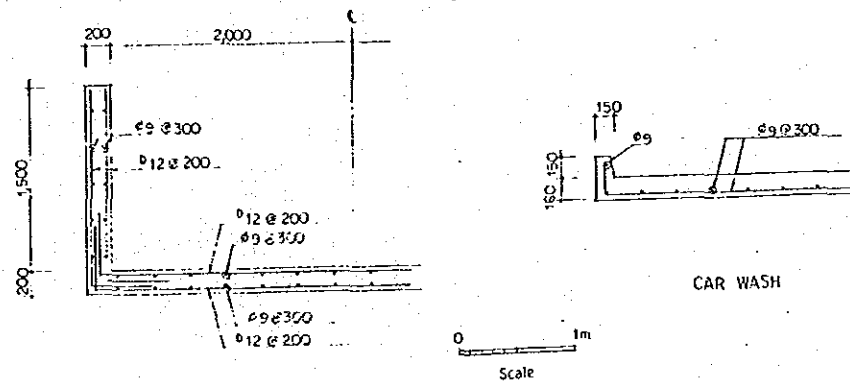

WATERTIGHTNESS TEST PIT  
 Reinforcement for both wall and floor in sloped portion shall be reduced proportionate to depth.

DIRECTORATE GENERAL OF FOOD CROP AGRICULTURE  
 THE MODEL INFRASTRUCTURE IMPROVEMENT WORKS FOR  
 THE CENTER FOR DEVELOPMENT OF APPROPRIATE AGRICULTURAL  
 ENGINEERING TECHNOLOGY (ATA-220)

REINFORCEMENT  
 FOR WAREHOUSE

JAPAN INTERNATIONAL COOPERATION AGENCY DWG NO. 19

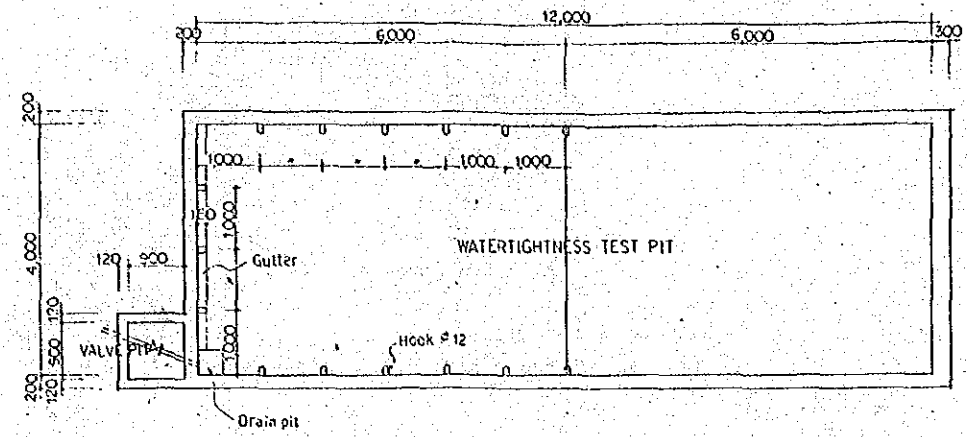

PLAN

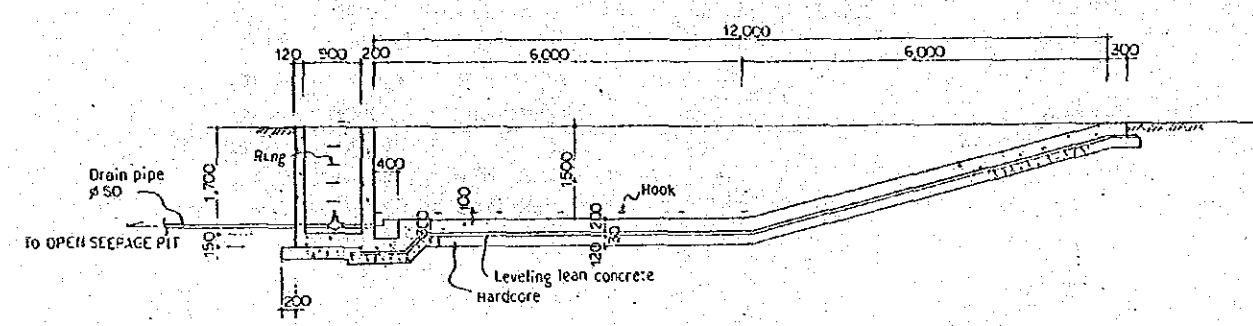
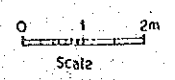

SECTION

WATERTIGHTNESS TEST PIT

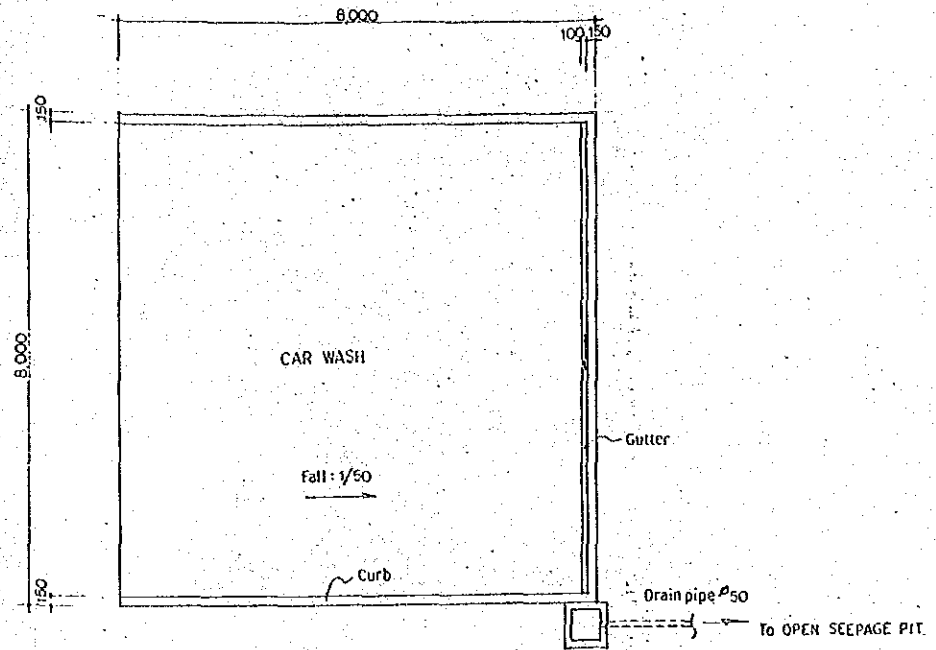

PLAN

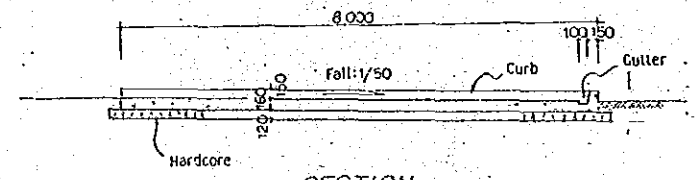
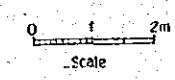

SECTION

CAR WASH

DIRECTORATE GENERAL OF FOOD CROP AGRICULTURE  
 THE MODEL INFRASTRUCTURE IMPROVEMENT WORKS FOR  
 THE CENTER FOR DEVELOPMENT OF APPROPRIATE AGRICULTURAL  
 ENGINEERING TECHNOLOGY (ATA-220)

**WATER TIGHTNESS TEST PIT  
 AND CARWASH**

JAPAN INTERNATIONAL COOPERATION AGENCY DWG NO. 20