

Annex IX 給水塔規模の検討

Annex IX 給水塔規模の検討

(1) 配水量の時間的变化

バングラデシュ国における配水量の時間的变化に関する資料がないので、日本の資料をもとに推定する。

(a) 各戸給水の時間的变化

バングラデシュ国では、日本とは生活環境、習慣が異なるため現在の日本の時間的变化をそのまま使用することは困難である。生活環境については、電気洗濯機、水洗便所、風呂等が主な違いである。これらの違いを修正するため、これらの普及率の低かった昭和30年頃(1955年)の資料を使用する。次図は日平均給水量を1.0とした時の各時間ごとの給水状況である。

Fig. A-9-1 各戸給水の時間別給水状況

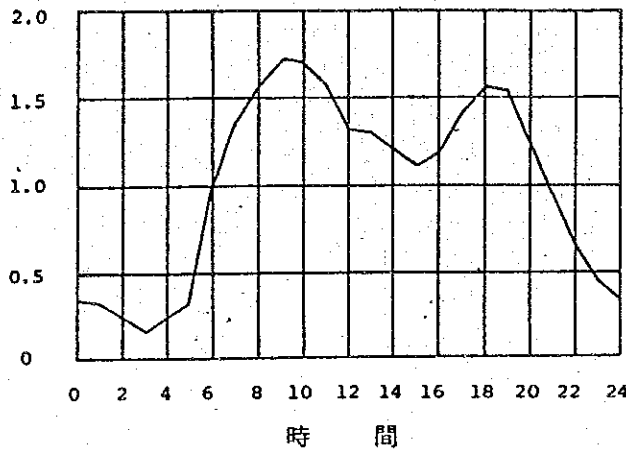

(b) 公共水栓の時間的变化

公共水栓の形態は、戦後の一時期には存在したが、現在は存在していないので資料がなく、推定によることとする。

水使用の内訳の一例は次のとおりである。

Drinking, cooking, dish washing, house cleaning	10.5 ℓ/人・日
Laundrying	5.0 "
Ablutions	17.5 "
Hand flash	2.5 "
Others	4.0 "
Total	39.5 "

これらのうち、洗濯は水栓場所で行なわれ、その他は各戸に水を運搬して使用されると考えられる。また、食事及び食器洗い等の水は食事の1～2時間前に汲み置きされると考えられる。

従って、各戸給水に比較して朝のピークは少なくなるとともに、朝夕のピークは1～2時間早くなる。夜間は汲み置きの水が使われるため、水栓からはほとんど使われなくなる。なお、計算にあたっては安全側とするため、朝夕の時間最大は同じとした。

Fig. A-9-2 公共水栓の時間別給水状況

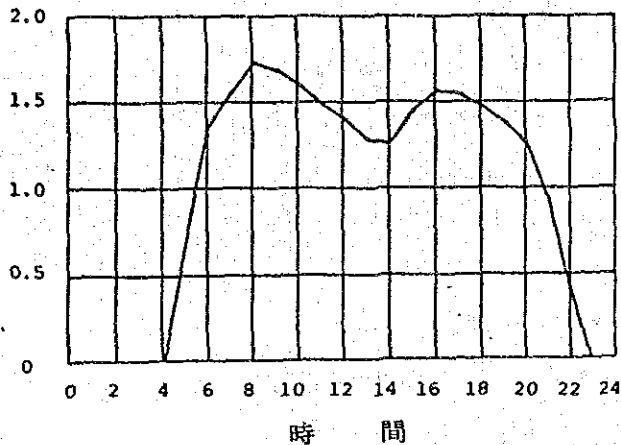

(2) 配水量の時間的变化の想定における時間最大給水量と日最大給水量の比の確認
 バングラデシュ国における時間最大比に関する資料はないので、日本の資料をもとに推定する。

(a) 各戸給水の場合

給水対象人口と時間最大比の関係は次図のようになる。

Fig. A-9-3 給水対象人口と時間最大比の関係

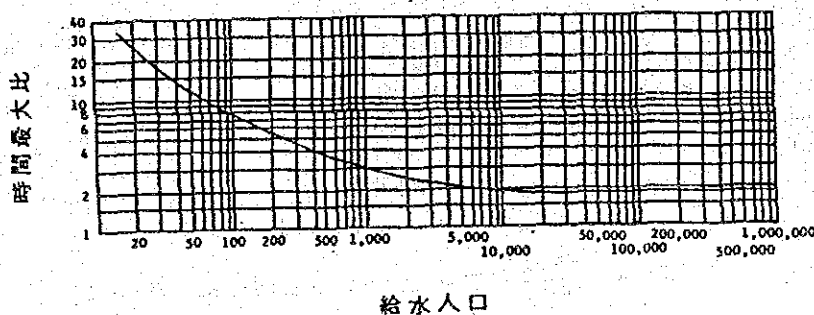

時間最大比(α)は次のようにして求める。

- ① Fig. A-9-3 から求めた α について、時間最大給水量 Q_H を求める。

$$Q_H = \alpha \times \frac{q_0}{24} \times P$$

- ② 一方、同時開栓水量 Q_1 を求める。

$$Q_1 = q_1 \times N^{0.475}$$

- ③ (a) $Q_H \leq Q_1$ の場合は Q_H を時間最大給水量とする。

- (b) $Q_H > Q_1$ の場合は Q_1 を時間最大給水量とする。

ここに P : 計画給水人口(人)

q_0 : 1人1日最大給水量 (ℓ /人・日)

q_1 : 水栓1栓使用量 (ℓ /分、 17ℓ /分、 $\phi 13 \text{mm}$ の場合)

N : 総水栓数

最大人口の Narayanganj Town の場合について時間最大給水量の計算を行なう。

- ① Fig. A-9-3 より $\alpha \doteq 1.7$ となる。

$$Q_H = 1.7 \times 113.7 \ell/\text{人} \cdot \text{日} \times 470,000 \text{人} \times 0.5 = 31,544 \ell/\text{分}$$

- ② $Q_1 = 17 \ell/\text{分} \times \left(\frac{470,000}{2 \times 11} \right)^{0.475} = 1,938 \ell/\text{分}$

Q_1 との差が大きすぎる。これは、バングラデシュ国の場合は、1家族当りの人数が平均11人と多く、また、各戸給水も単栓であるため、日本の例は当てはまらないものと判断される。

これらのことから、 Q_H は時間最大比から求めた方がよいと思われる。

- (b) 公共水栓の場合

公共水栓の場合も時間最大比から求めるものとする。

- (c) 総給水量の時間最大比

配水量の時間的変化をもとに、総給水量の時間最大比を求めると Table A-9-1 のとおり $\alpha' = 1.71$ となる。これは Fig. A-9-3 より求めた $\alpha = 1.7$ に近似となるので(1)で検討した配水量分布を用いることとする。

Table A-9-1 総給水量の時間最大比 (1人当り)

Hour	House connection		Public post		Total
	Ratio	Water Volume (x 90 l)	Ratio	Water Volume (x 34 l)	
0	0.33	37.5	0	0	37.5
1	0.24	27.3	0	0	27.3
2	0.19	21.6	0	0	21.6
3	0.14	15.9	0	0	15.9
4	0.12	13.6	0	0	13.6
5	0.31	35.2	0.70	23.80	59.0
6	0.98	111.4	1.33	45.22	156.6
7	1.33	151.2	1.54	52.36	203.6
8	1.57	178.5	1.72	58.48	237.0
9	1.72	195.5	1.68	57.12	252.6
10	1.69	192.2	1.60	54.40	246.6
11	1.56	177.4	1.49	50.66	228.1
12	1.34	152.4	1.40	47.60	200.0
13	1.29	146.7	1.28	43.52	190.2
14	1.22	138.7	1.26	42.84	181.5
15	1.10	125.1	1.45	49.30	174.4
16	1.17	133.0	1.56	53.04	186.0
17	1.39	158.0	1.54	52.36	210.4
18	1.56	177.4	1.50	51.00	228.4
19	1.54	175.1	1.40	47.60	222.7
20	1.25	142.1	1.25	42.50	184.6
21	0.91	103.5	0.91	30.94	134.4
22	0.62	70.5	0.39	13.26	83.8
23	0.43	48.9	0	0	48.9
Average	1.00	113.7	1.00	34.00	147.7

$$\text{Hourly maximum ratio } \alpha' = \frac{211.92}{124.00} = 1.71$$

(3) 給水塔容量の検討

前項までの数値をもとに、計画1日最大給水量の20%の容量で24時間給水可能か否かを計画年次1990年と施設完成予定時1989年の2ケースについて検討を行なう。

計画年次1990年については運転時間を7時～22時と6時～21時の2ケースで1989年については、運転時間7時～22時でいずれも15時間運転とする。

計算結果 (Table A-9-3～9-5) を整理して表示すると次表のようになる。

Table A-9-2 計算結果

条 件		結 果
1990年	給水塔容量 20% 運 転 時 間 15時間 (7～22時)	断水あり。午前7時の運転開始前に僅かに、貯水量が不足する(処理水量の0.4分分である)
	給水塔容量 20% 運 転 時 間 15時間 (6～21時)	断水なし。午前6時の運転開始前にもなお僅かではあるが貯水量が残存する。(処理水量の0.2分分である)
1989年	給水塔容量 20% 運 転 時 間 15時間 (7～22時)	断水なし。午前7時の運転開始前にもなお処理水量の6.7分分の貯水量が残存する。

(4) 給水塔容量の決定

給水塔容量を日給水量の20%で、運転時間を15時間とした上記検討の結果、1989年の場合は完全に24時間給水が可能であり、計画年次1990年においてもほとんど24時間給水が可能である。また1991年以降についても運転時間を増すことによつて24時間給水が可能である。従つて給水塔容量は日給水量の20%とする。

Table A-9-3 給水塔容量の検討

NAME OF CITY: Narayananj
 POPULATION SUPPLIED: 1990
 RESERVOIR QUANTITY: 20%
 OPERATION HOUR FROM: 7 TO 22

HR	RATIO	HOUSE	RATIO	PUBLIC	UNKNOWN	TOTAL	SUPPLY	TANK
0	0.33	37.5	0.00	0	63.3	100.8	0	652.7
1	0.24	27.5	0.00	0	63.3	90.6	0	562.1
2	0.19	21.6	0.00	0	63.3	84.9	0	477.2
3	0.14	15.9	0.00	0	63.3	79.2	0	398.0
4	0.12	13.6	0.00	0	63.3	76.9	0	321.1
5	0.31	35.2	0.70	23.8	63.3	122.3	0	198.8
6	0.98	111.4	1.33	45.2	63.3	219.9	0	-21.1 (0.4 minute)
7	1.33	151.2	1.54	52.4	63.3	266.9	337.6	70.7
8	1.57	178.5	1.72	58.5	63.3	300.3	337.6	108.0
9	1.72	195.5	1.68	57.1	63.3	315.9	337.6	129.7
10	1.69	192.2	1.60	54.4	63.3	309.9	337.6	157.4
11	1.56	177.4	1.49	50.7	63.3	291.4	337.6	203.6
12	1.36	152.4	1.40	47.6	63.3	263.3	337.6	277.9
13	1.29	146.7	1.28	43.5	63.3	253.5	337.6	362.0
14	1.22	138.7	1.26	42.8	63.3	244.8	337.6	454.8
15	1.10	125.1	1.45	49.3	63.3	237.7	337.6	554.7
16	1.17	133.0	1.56	53.0	63.3	249.3	337.6	643.0
17	1.39	158.0	1.54	52.4	63.3	273.7	337.6	706.9
18	1.56	177.4	1.50	51.0	63.3	271.7	337.6	772.8
19	1.54	175.1	1.40	47.6	63.3	286.0	337.6	824.4
20	1.25	142.1	1.25	42.5	63.3	247.9	337.6	914.1
21	0.91	103.5	0.91	30.9	63.3	197.7	337.6	1,054.0 - 1,012.8
22	0.62	70.5	0.39	13.3	63.3	147.1	0	865.7
23	0.43	48.9	0.00	0	63.3	112.2	0	753.5
TOTAL	24.00	2,728.8	24.00	816.0	1,519.2	5,064.0		

Table A-9-4 給水塔容量の検討

NAME OF CITY: Narayanganj
 POPULATION SUPPLIED: 1990
 RESERVOIR QUANTITY: 20%
 OPERATION HOUR FROM: 6 TO 21

HR	RATIO	HOUSE	RATIO	PUBLIC	UNKNOWN	TOTAL	SUPPLY	TANK
0	0.33	37.5	0.00	0	63.3	100.8	0	455.0
1	0.24	27.5	0.00	0	63.3	90.6	0	364.4
2	0.19	21.6	0.00	0	63.3	84.9	0	279.5
3	0.14	15.9	0.00	0	63.3	79.2	0	200.3
4	0.12	13.6	0.00	0	63.3	76.9	0	123.4
5	0.31	35.2	0.70	23.8	63.3	122.3	0	1.1 (0.2 minute)
6	0.98	111.4	1.33	45.2	63.3	219.9	337.6	117.7
7	1.33	151.2	1.54	52.4	63.3	266.9	337.6	188.4
8	1.57	178.5	1.72	58.5	63.3	300.3	337.6	225.7
9	1.72	195.5	1.68	57.1	63.3	315.9	337.6	247.4
10	1.69	192.2	1.60	54.4	63.3	309.9	337.6	275.1
11	1.56	177.4	1.49	50.7	63.3	291.4	337.6	321.3
12	1.34	152.4	1.40	47.6	63.3	263.3	337.6	395.6
13	1.29	146.7	1.28	43.5	63.3	253.5	337.6	479.7
14	1.22	138.7	1.26	42.8	63.3	244.8	337.6	572.5
15	1.10	125.1	1.45	49.3	63.3	237.7	337.6	672.4
16	1.17	133.0	1.56	53.0	63.3	249.3	337.6	760.7
17	1.39	158.0	1.54	52.4	63.3	273.7	337.6	824.6
18	1.56	177.4	1.50	51.0	63.3	271.7	337.6	890.5
19	1.54	175.1	1.40	47.6	63.3	286.0	337.6	942.1
20	1.25	142.1	1.25	42.5	63.3	247.9	337.6	1,031.8 - 1,012.8
21	0.91	103.5	0.91	30.9	63.3	197.7	0	815.1
22	0.62	70.5	0.39	13.3	63.3	147.1	0	668.0
23	0.43	48.9	0.00	0	63.3	112.2	0	555.8
TOTAL	24.00	2,728.8	24.00	816.0	1,519.2			

Table A-9-5 給水塔容量の検討

NAME OF CITY: Narayanganj
 POPULATION SUPPLIED: 1989 (1990 x 94.3%)
 RESERVOIR QUANTITY: 20%
 OPERATION HOUR FROM: 7 TO 22

HR	RATIO	HOUSE	RATIO	PUBLIC	UNKNOWN	TOTAL	SUPPLY	TANK (1,012.8)
0	0.33		0.00	0		95.1	0	673.2
1	0.24		0.00	0		85.4	0	587.8
2	0.19		0.00	0		80.1	0	507.7
3	0.14		0.00	0		74.7	0	433.0
4	0.12		0.00	0		72.5	0	360.5
5	0.31		0.70			115.3	0	245.2
6	0.98		1.33			207.4	0	37.8 (6.7 minutes)
7	1.33		1.54			251.7	337.6	
8	1.57		1.72			283.2	337.6	
9	1.72		1.68			297.9	337.6	
10	1.69		1.60			292.2	337.6	
11	1.56		1.49			274.8	337.6	
12	1.34		1.40			248.3	337.6	
13	1.29		1.28			239.1	337.6	
14	1.22		1.26			230.8	337.6	
15	1.10		1.45			224.1	337.6	
16	1.17		1.56			235.1	337.6	
17	1.39		1.54			258.1	337.6	
18	1.56		1.50			256.2	337.6	
19	1.54		1.40			269.7	337.6	
20	1.25		1.25			233.8	337.6	
21	0.91		0.91			186.4	337.6	
22	0.62		0.39			138.7	0	874.1
23	0.43		0.00			105.8	0	768.3
TOTAL	24.00		24.00					- 1,012.8

DRAWINGS

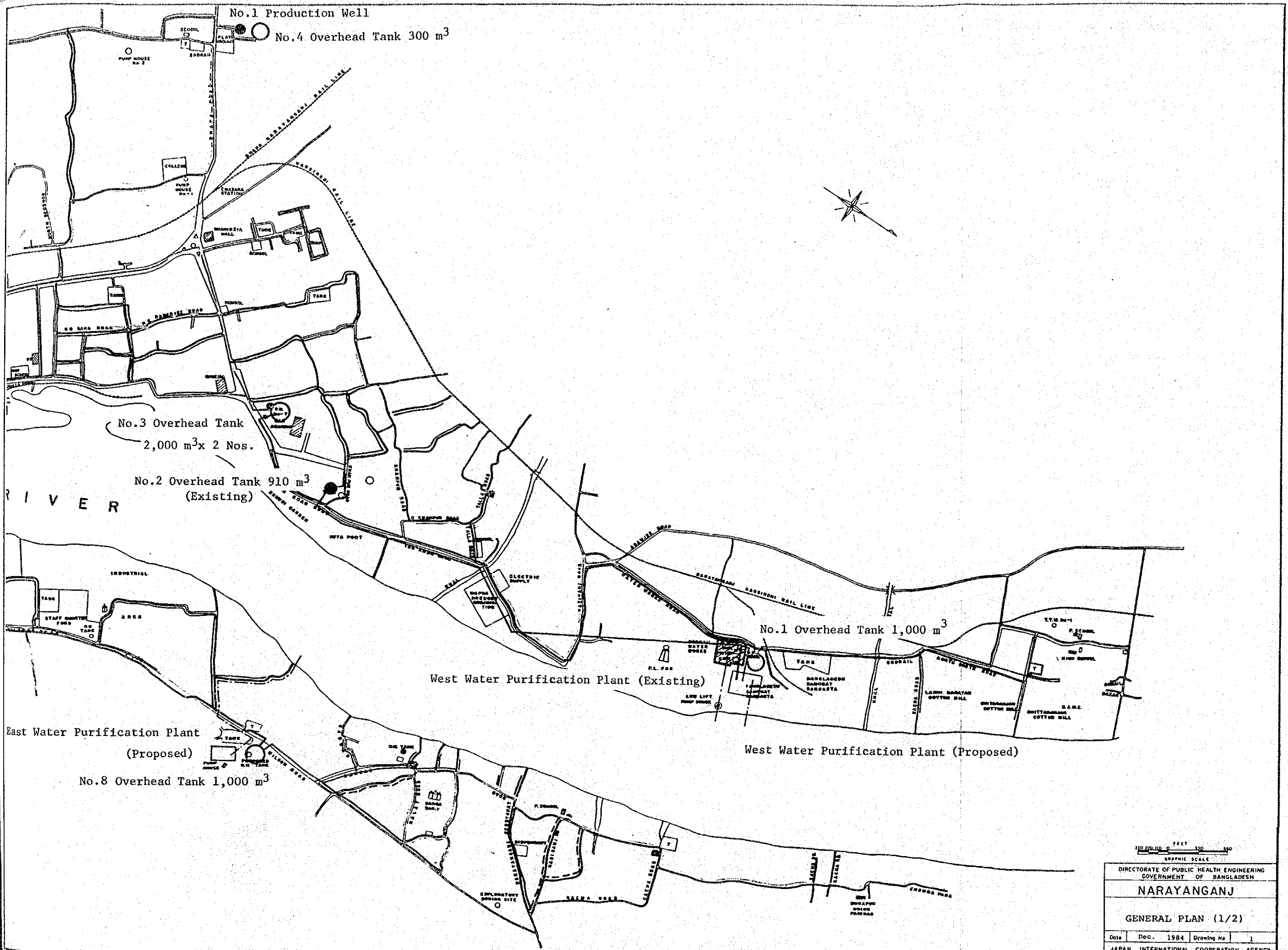

310 270 110 0 330 540	
GRAPHIC SCALE	
DIRECTORATE OF PUBLIC HEALTH ENGINEERING GOVERNMENT OF BANGLADESH	
NARAYANGANJ	
GENERAL PLAN (1/2)	
Date	Dec. 1984
Drawing No	1
JAPAN INTERNATIONAL COOPERATION AGENCY	

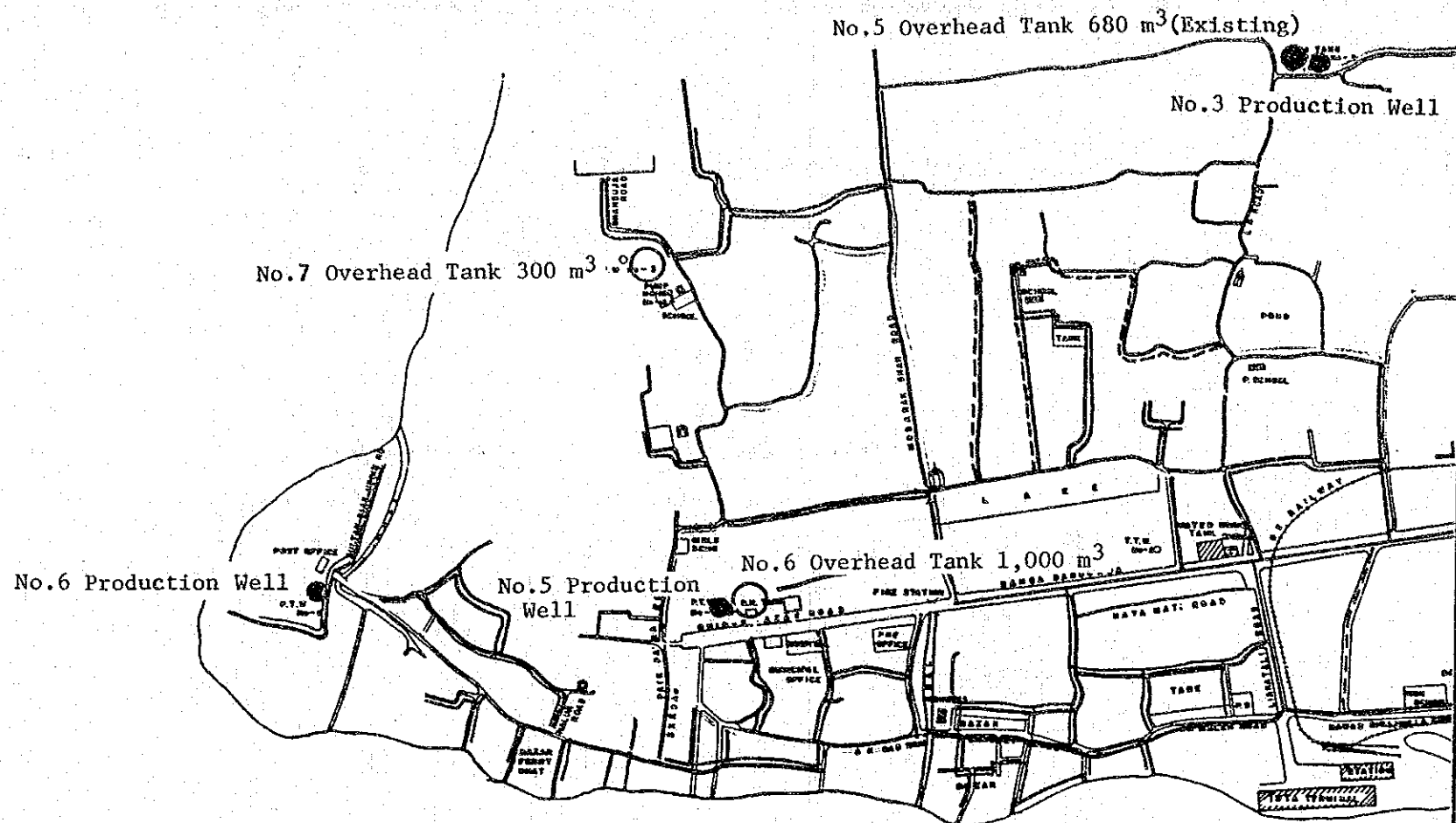

S I T A L A K H Y A R I

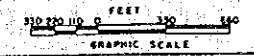
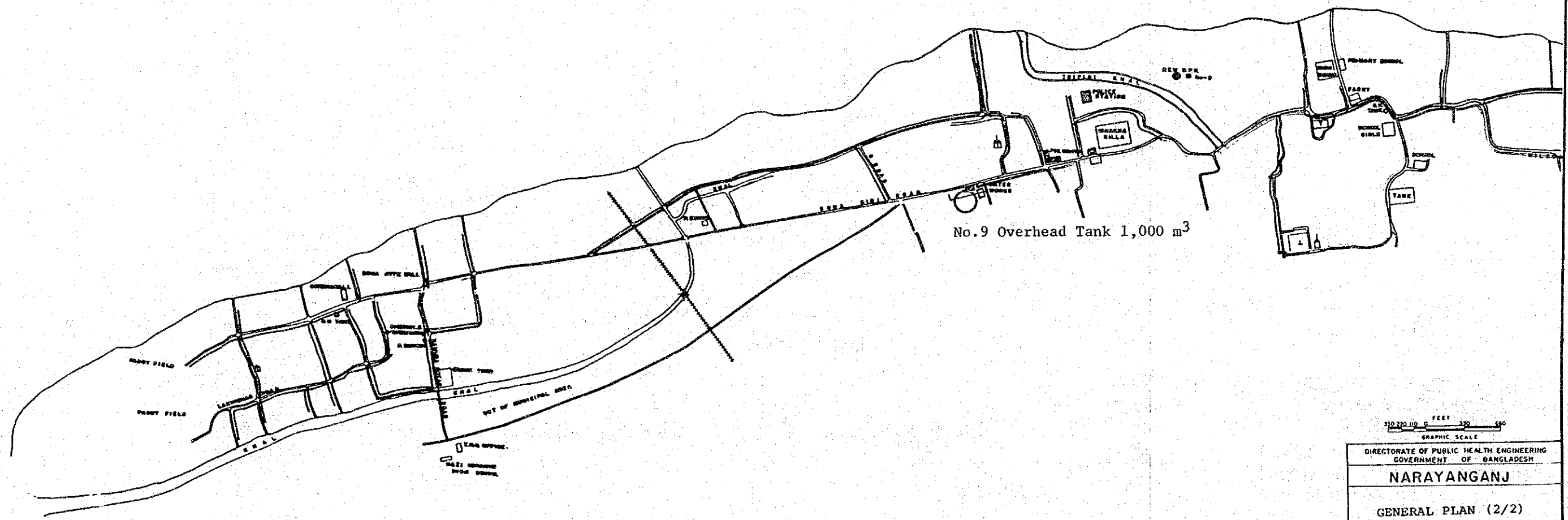

DIRECTORATE OF PUBLIC HEALTH ENGINEERING GOVERNMENT OF BANGLADESH			
NARAYANGANJ			
GENERAL PLAN (2/2)			
Date	Dec. 1984	Drawing No.	2
JAPAN INTERNATIONAL COOPERATION AGENCY			

GENERAL PLAN SCALE 1/300

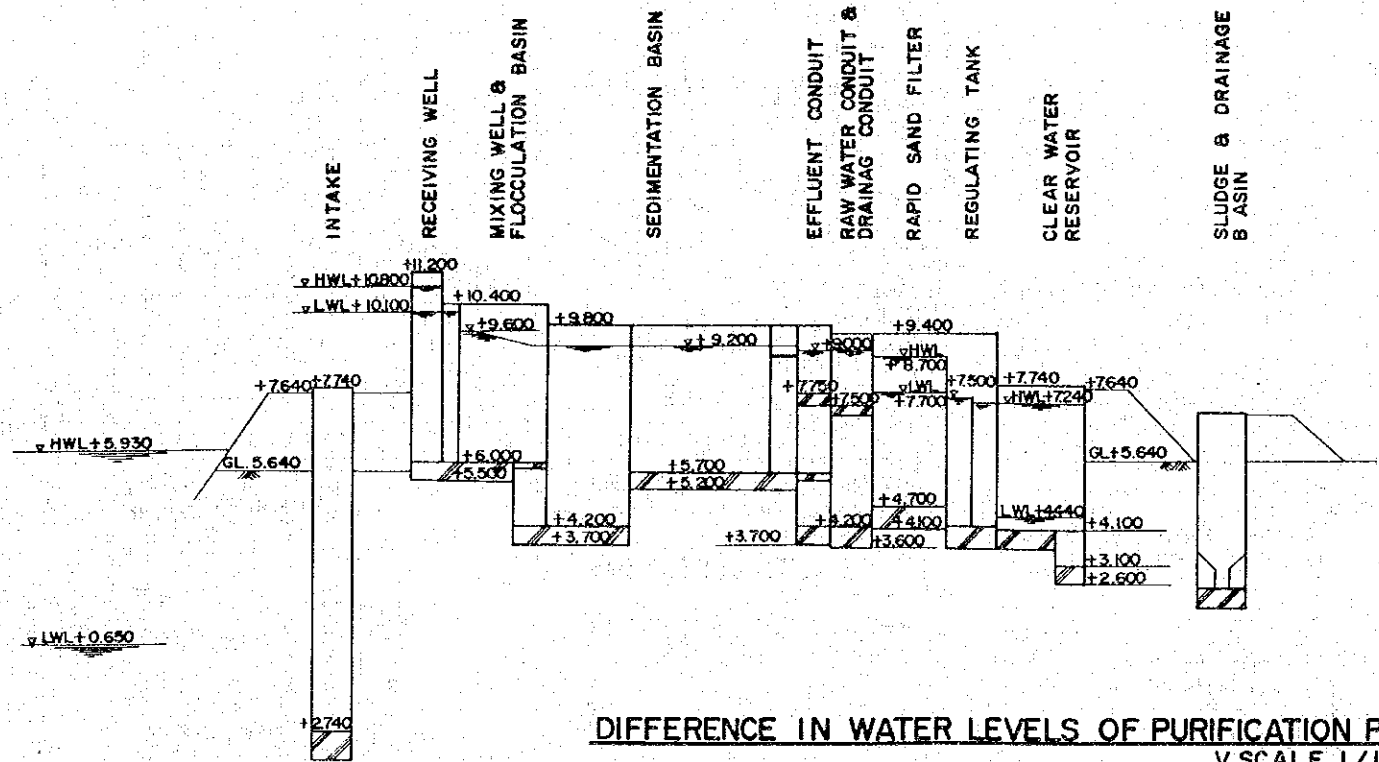
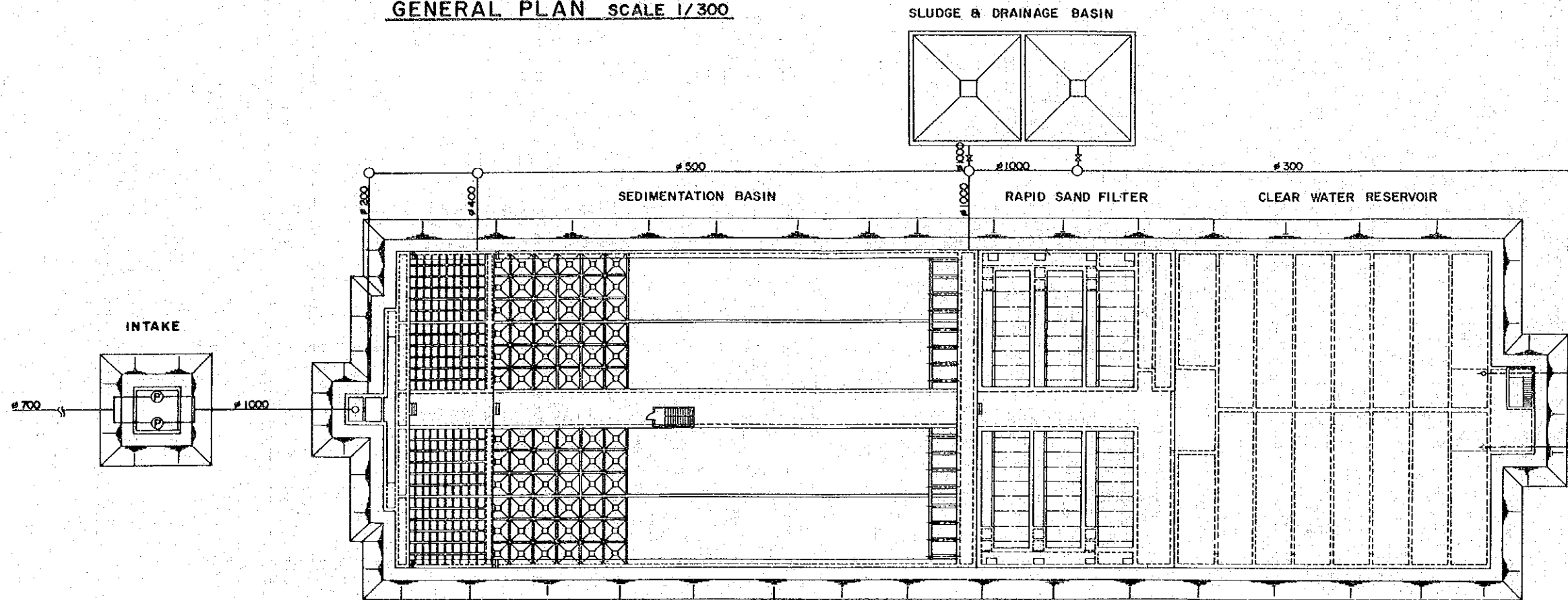

DIFFERENCE IN WATER LEVELS OF PURIFICATION PLANT
V. SCALE 1/100

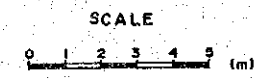
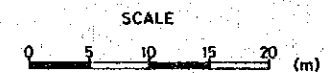

DIRECTORATE OF PUBLIC HEALTH ENGINEERING GOVERNMENT OF BANGLADESH			
NARAYANGANJ			
WEST PURIFICATION PLANT			
GENERAL PLAN AND DIFFERENCE IN WATER LEVELS			
Date	Dec. 1984	Drawing No	3
JAPAN INTERNATIONAL COOPERATION AGENCY			

PLAN

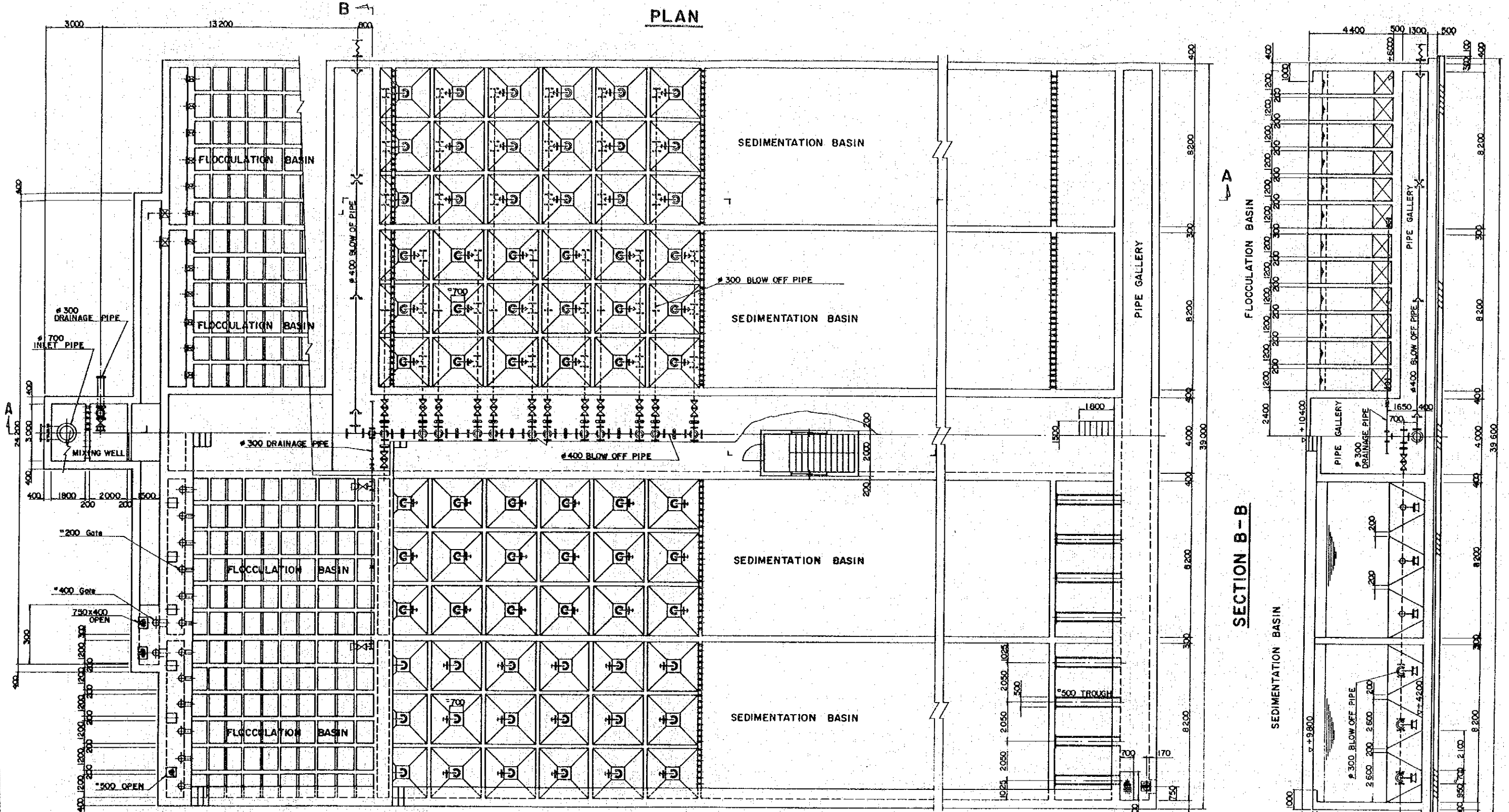

SECTION B-B

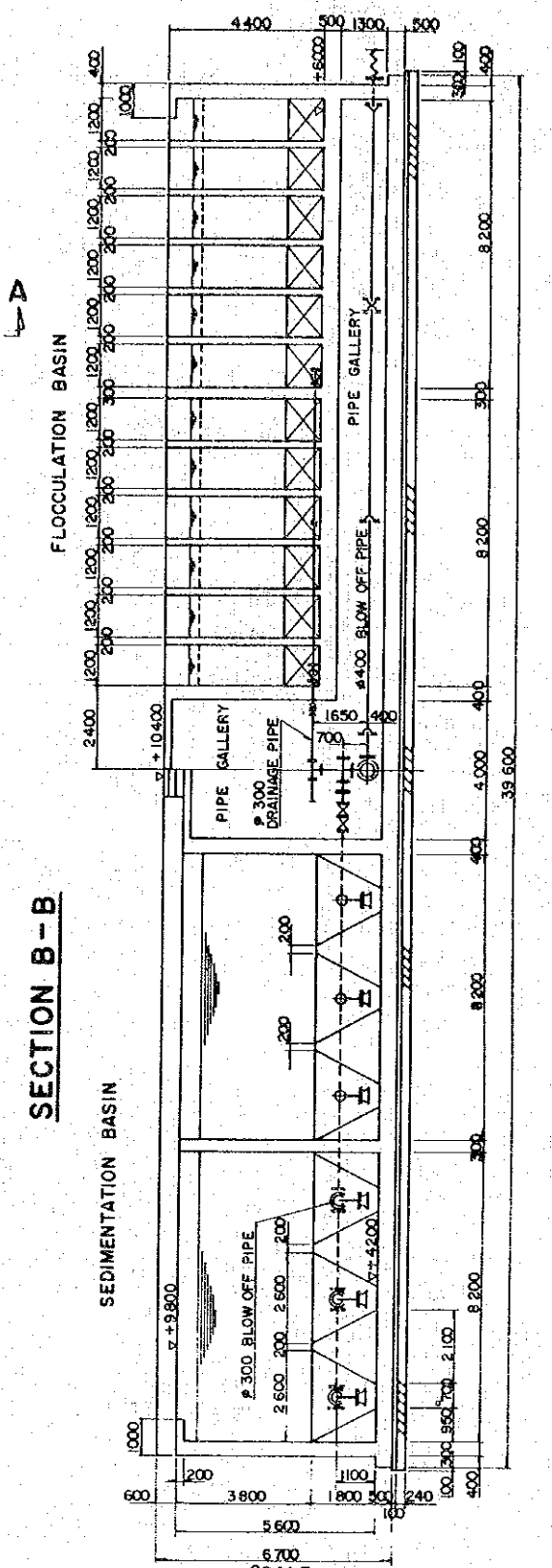

SECTION A-A

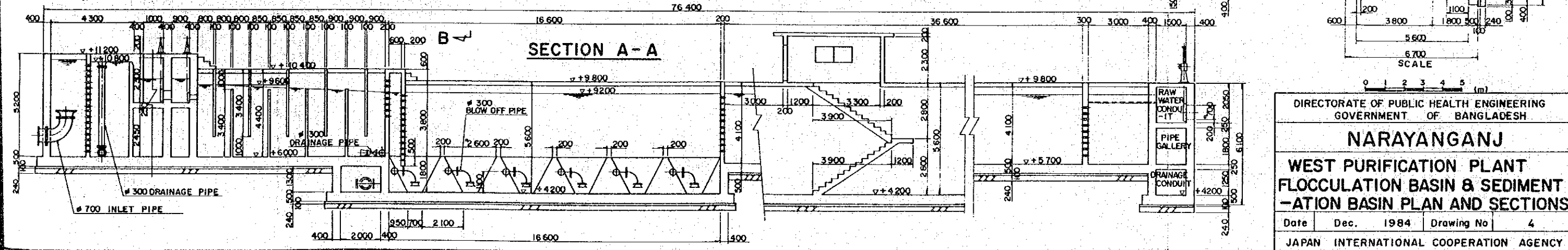

DIRECTORATE OF PUBLIC HEALTH ENGINEERING GOVERNMENT OF BANGLADESH			
NARAYANGANJ			
WEST PURIFICATION PLANT FLOCCULATION BASIN & SEDIMENTATION BASIN PLAN AND SECTIONS			
Date	Dec. 1984	Drawing No	4
JAPAN INTERNATIONAL COOPERATION AGENCY			

PLAN

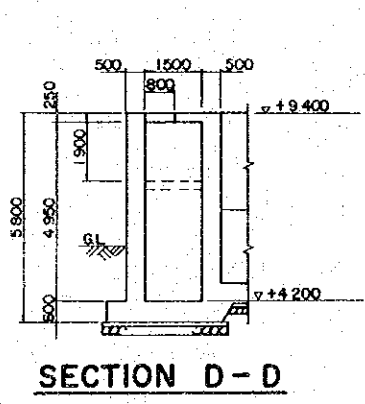
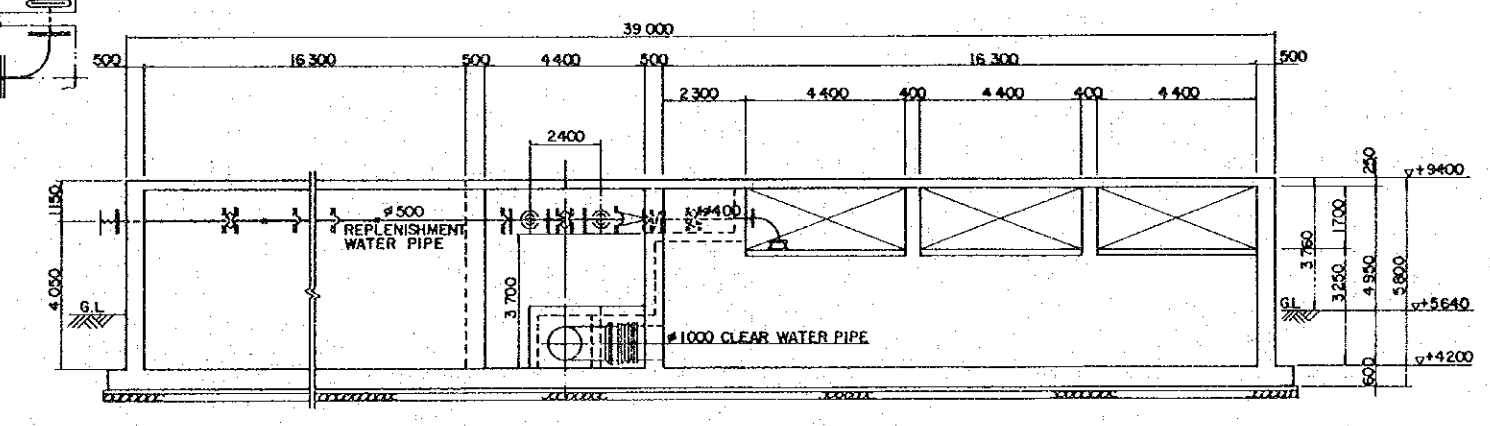
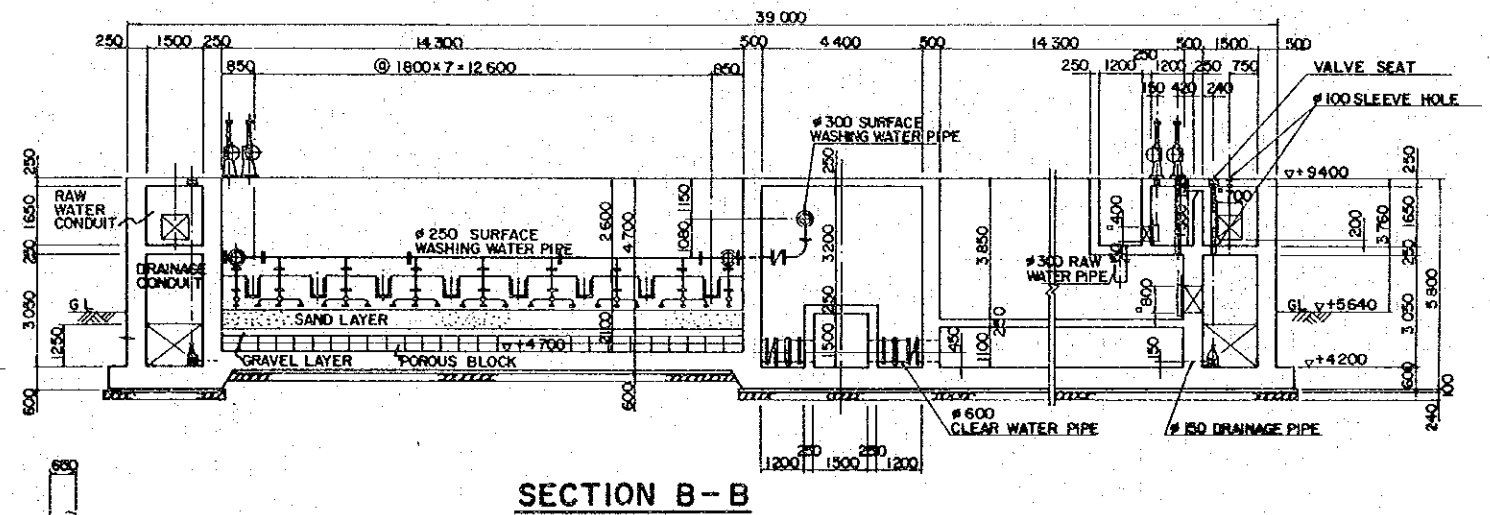
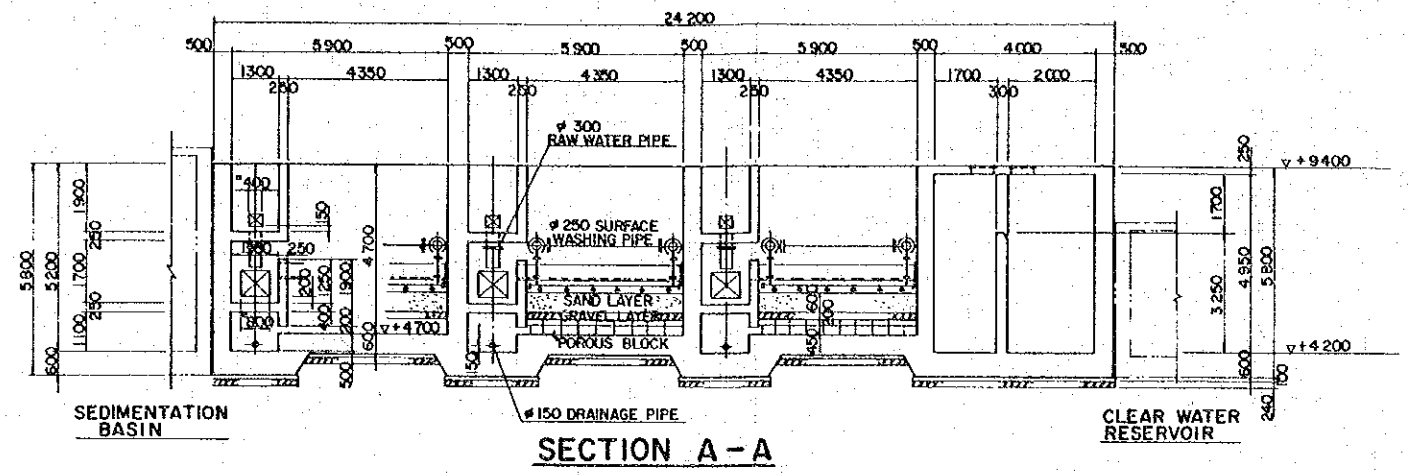
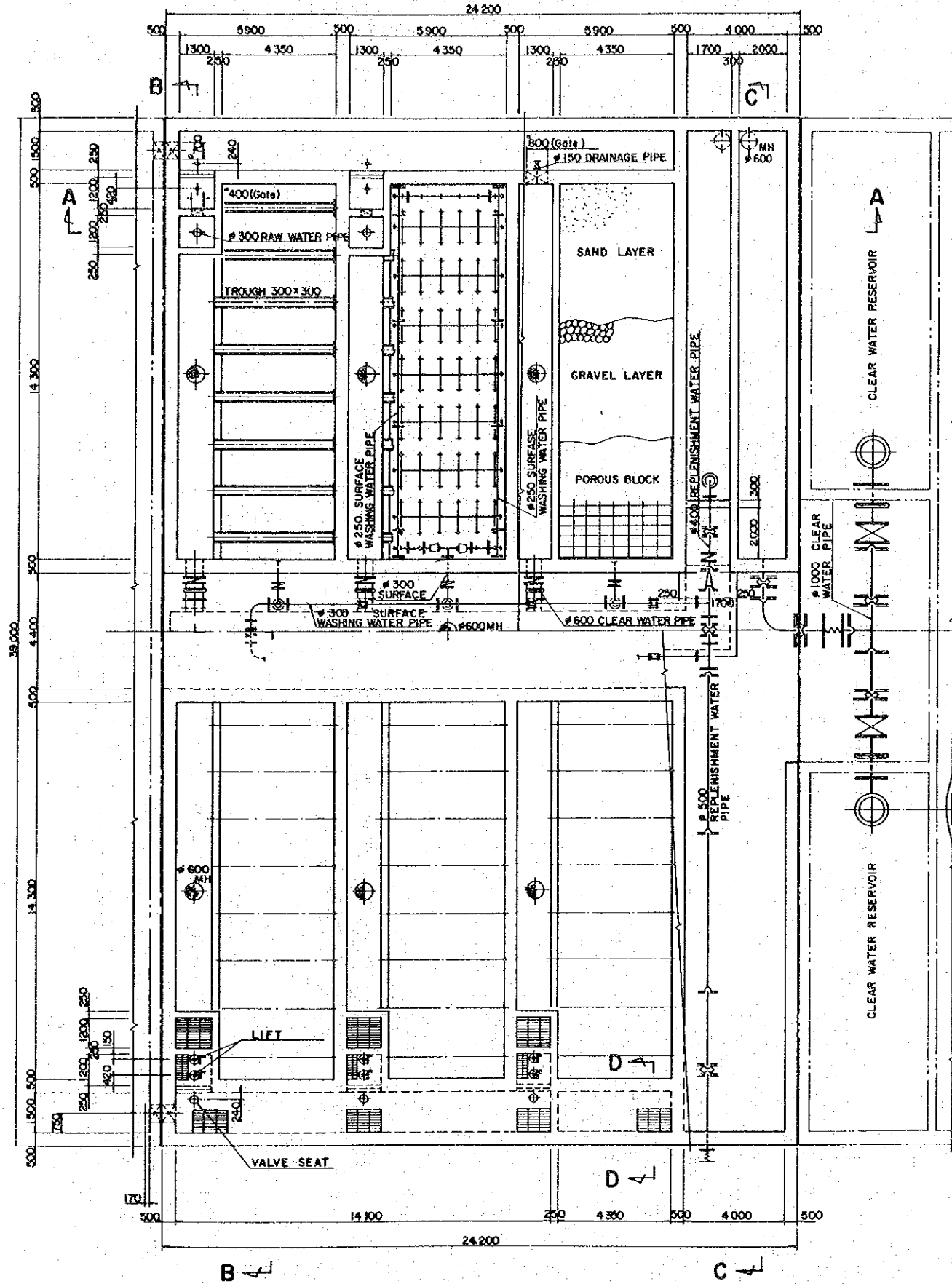

SECTION A - A

SECTION B - B

SECTION C - C

SECTION D - D

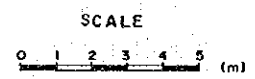

DIRECTORATE OF PUBLIC HEALTH ENGINEERING GOVERNMENT OF BANGLADESH			
NARAYANGANJ			
WEST PURIFICATION PLANT RAPID SAND FILTER PLAN AND SECTIONS			
Date	Dec. 1984	Drawing No	5
JAPAN INTERNATIONAL COOPERATION AGENCY			

PLAN

B

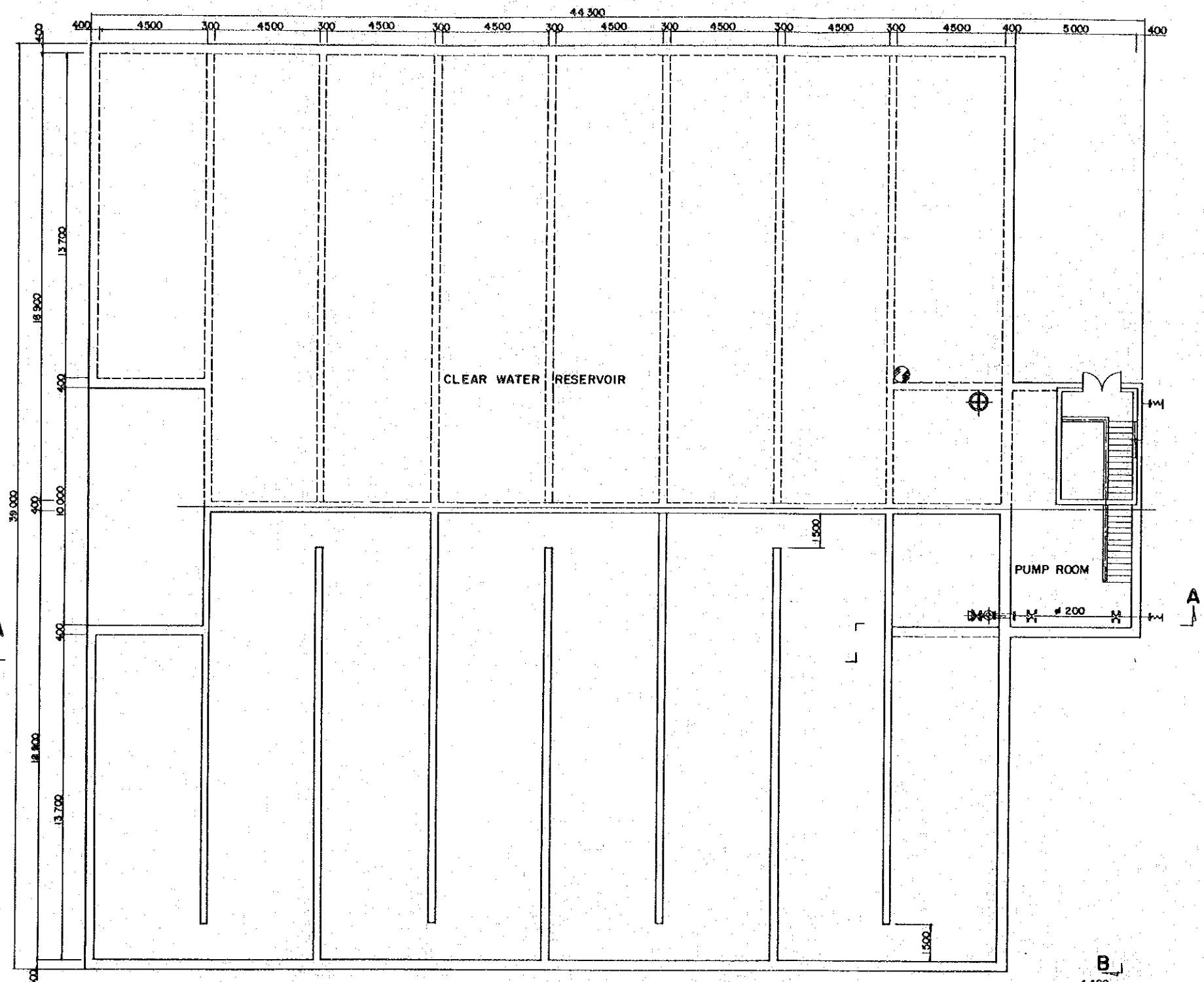

SECTION A-A

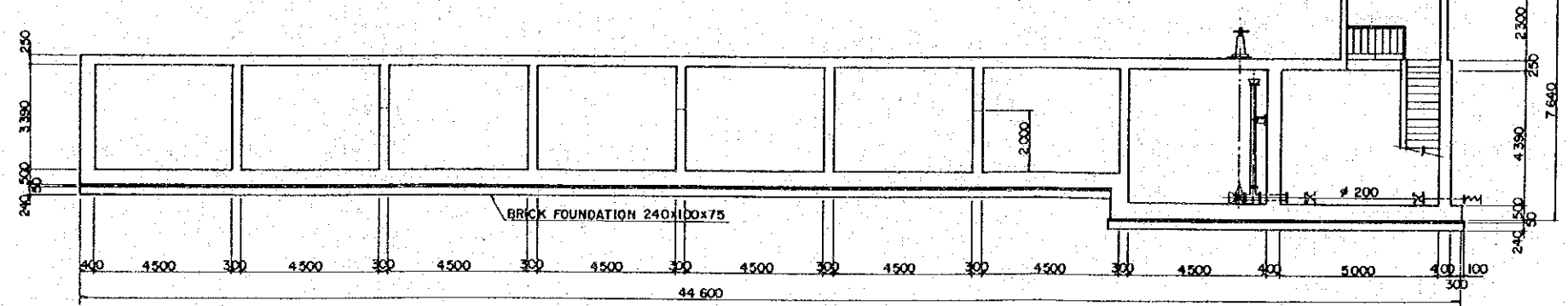

SECTION B-B

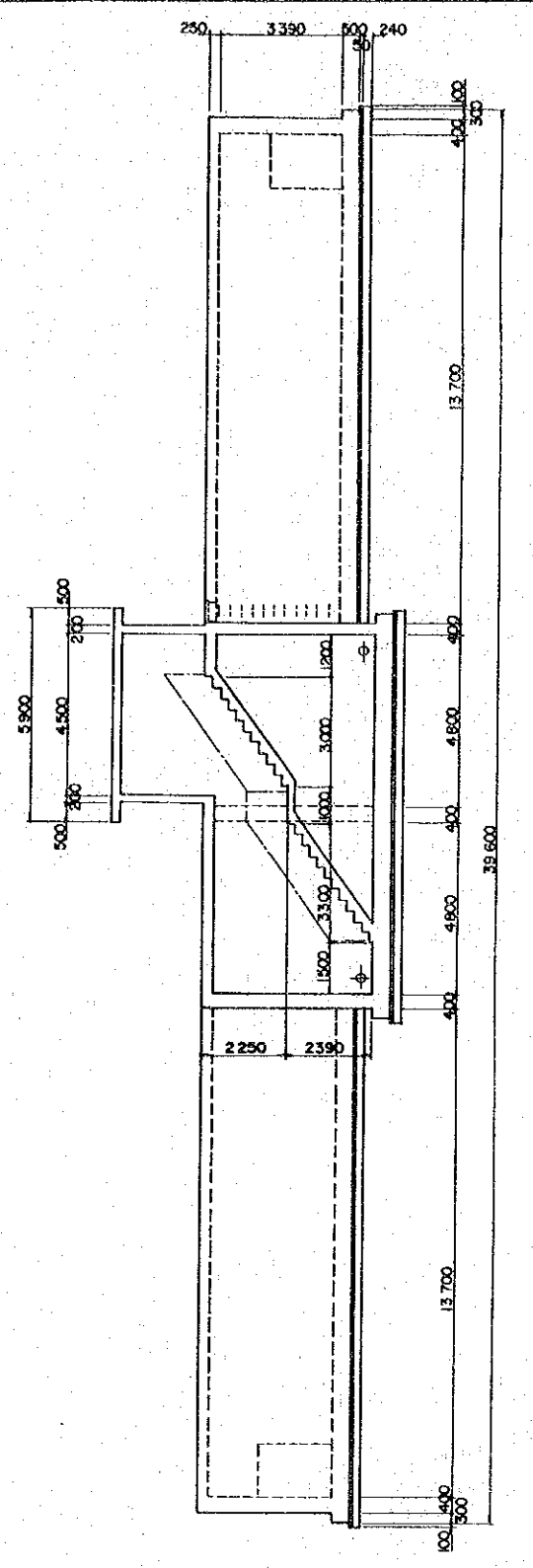

DIRECTORATE OF PUBLIC HEALTH ENGINEERING GOVERNMENT OF BANGLADESH			
NARAYANGANJ			
WEST PURIFICATION PLANT CLEAR WATER RESERVOIR PLAN AND SECTIONS			
Date	Dec. 1984	Drawing No	6
JAPAN INTERNATIONAL COOPERATION AGENCY			

PLAN

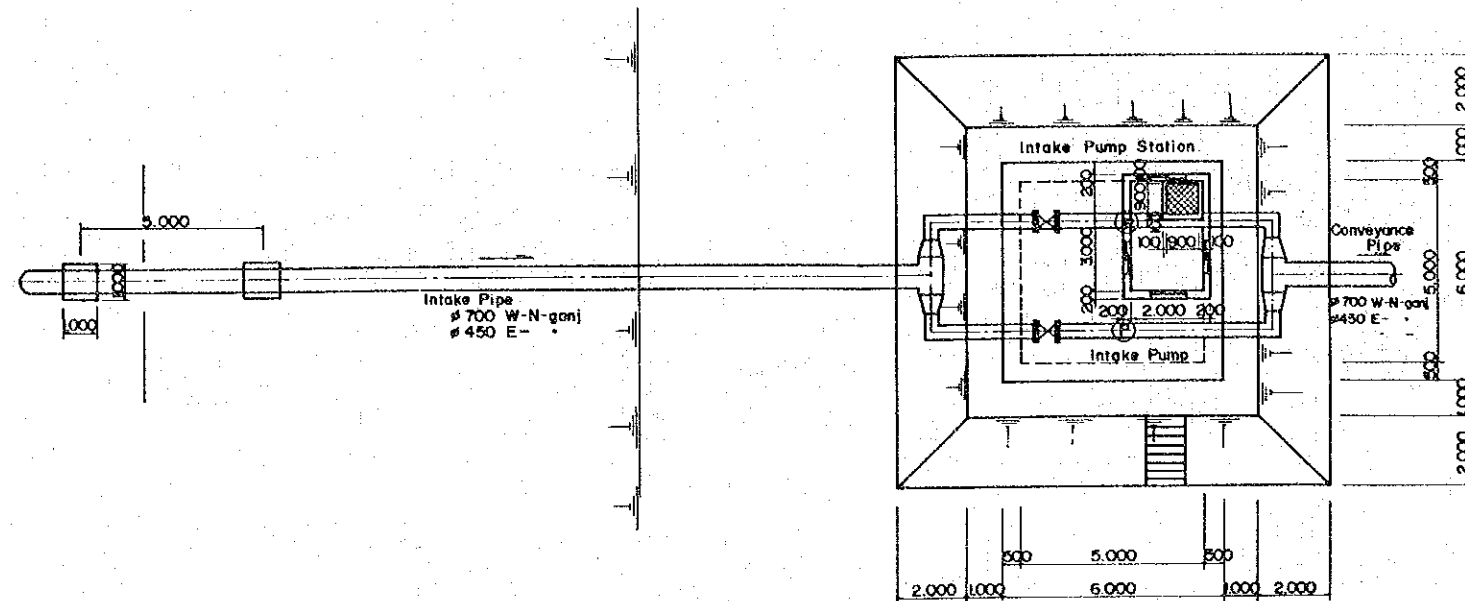

CROSS SECTION

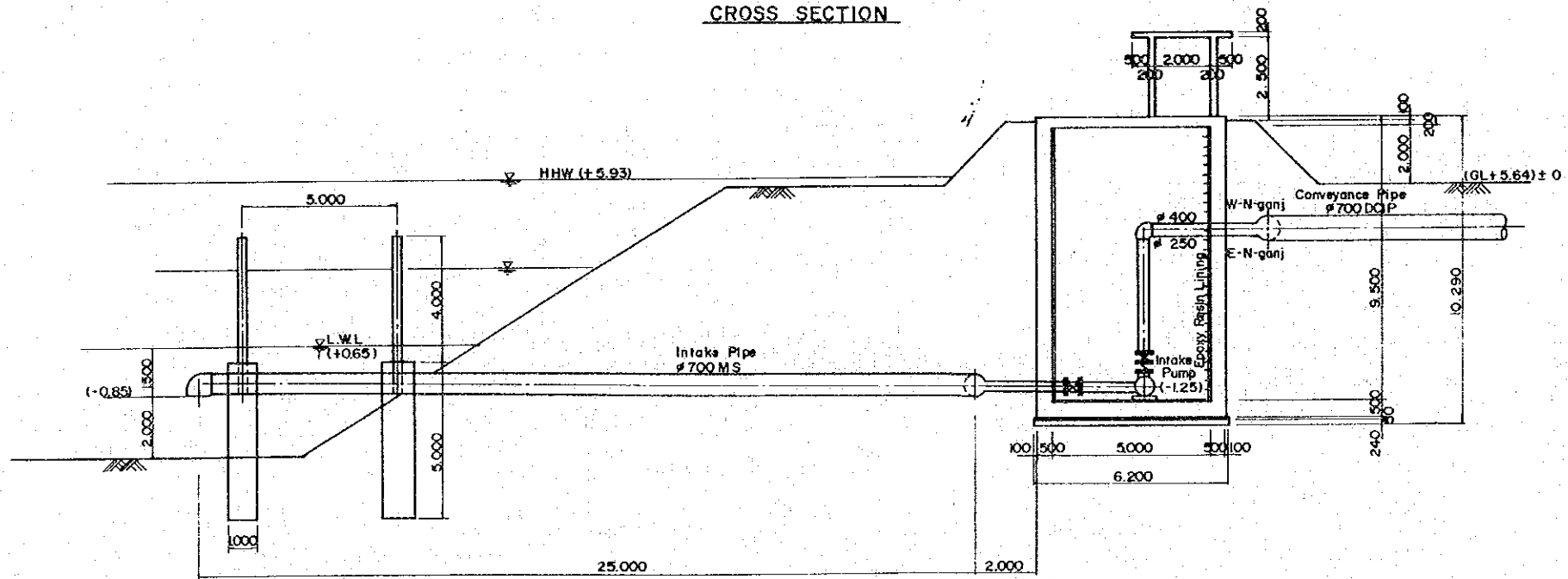

DIRECTORATE OF PUBLIC HEALTH ENGINEERING GOVERNMENT OF BANGLADESH			
NARAYANGANJ			
WEST & EAST PURIFICATION PLANT INTAKE FACILITIES			
Date	Dec. 1984	Drawing No.	7, 13
JAPAN INTERNATIONAL COOPERATION AGENCY			

PLAN

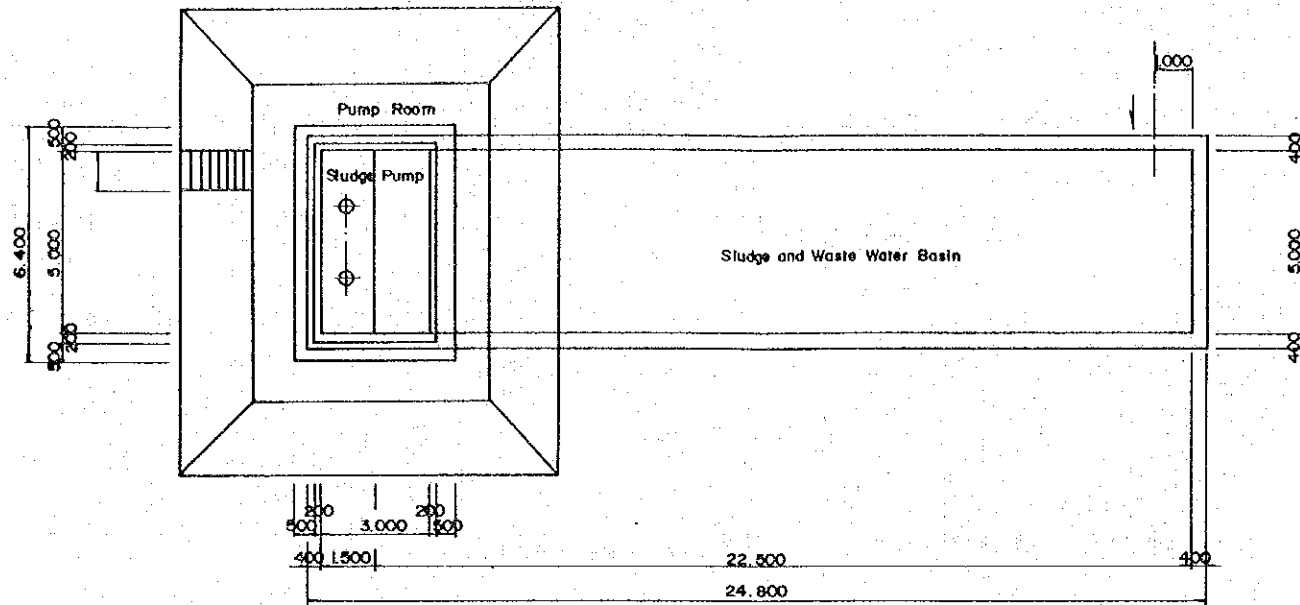

CROSS SECTION

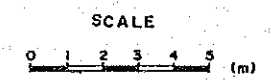
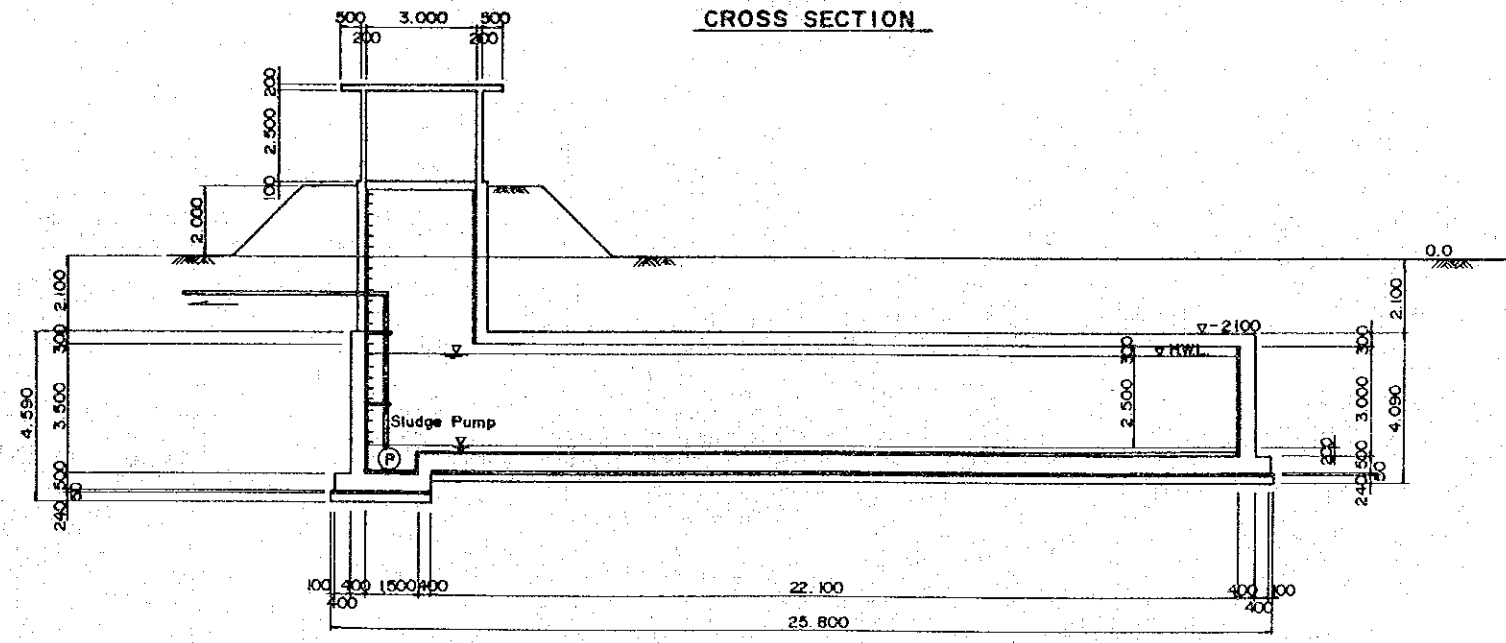

DIRECTORATE OF PUBLIC HEALTH ENGINEERING GOVERNMENT OF BANGLADESH			
NARAYANGANJ			
WEST PURIFICATION PLANT SLUDGE AND WASHING WATER BASIN			
Date	Dec. 1984	Drawing No.	8
JAPAN INTERNATIONAL COOPERATION AGENCY			

GENERAL PLAN SCALE 1/300

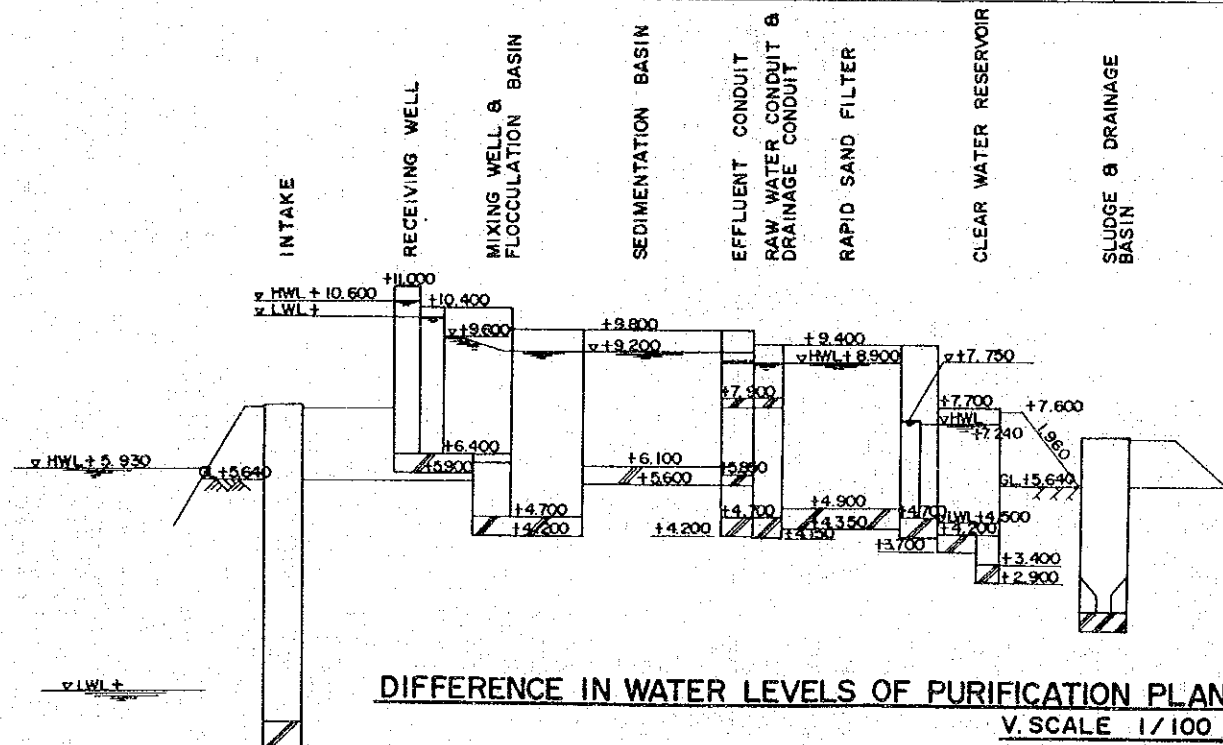
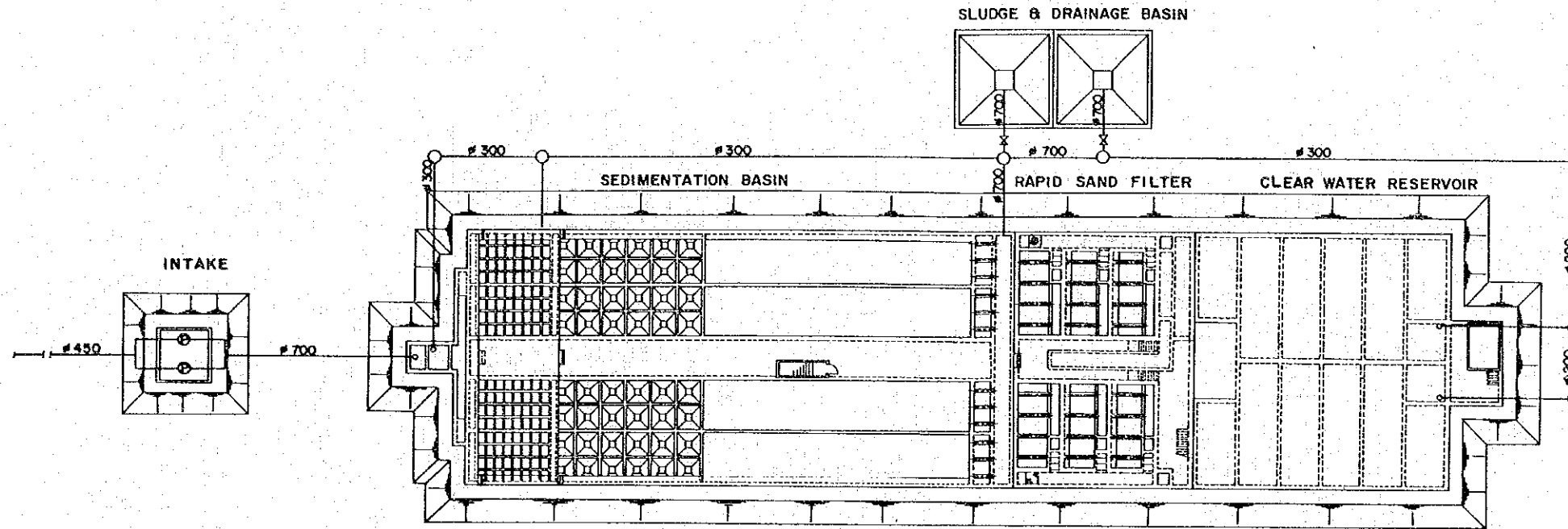

SCALE
0 1 2 3 4 5 (m)

SCALE
0 5 10 15 20 (m)

DIRECTORATE OF PUBLIC HEALTH ENGINEERING GOVERNMENT OF BANGLADESH			
NARAYANGANJ			
EAST PURIFICATION PLANT GENERAL PLAN AND DIFFERENCE IN WATER LEVELS			
Date	Dec. 1984	Drawing No	9
JAPAN INTERNATIONAL COOPERATION AGENCY			

PLAN

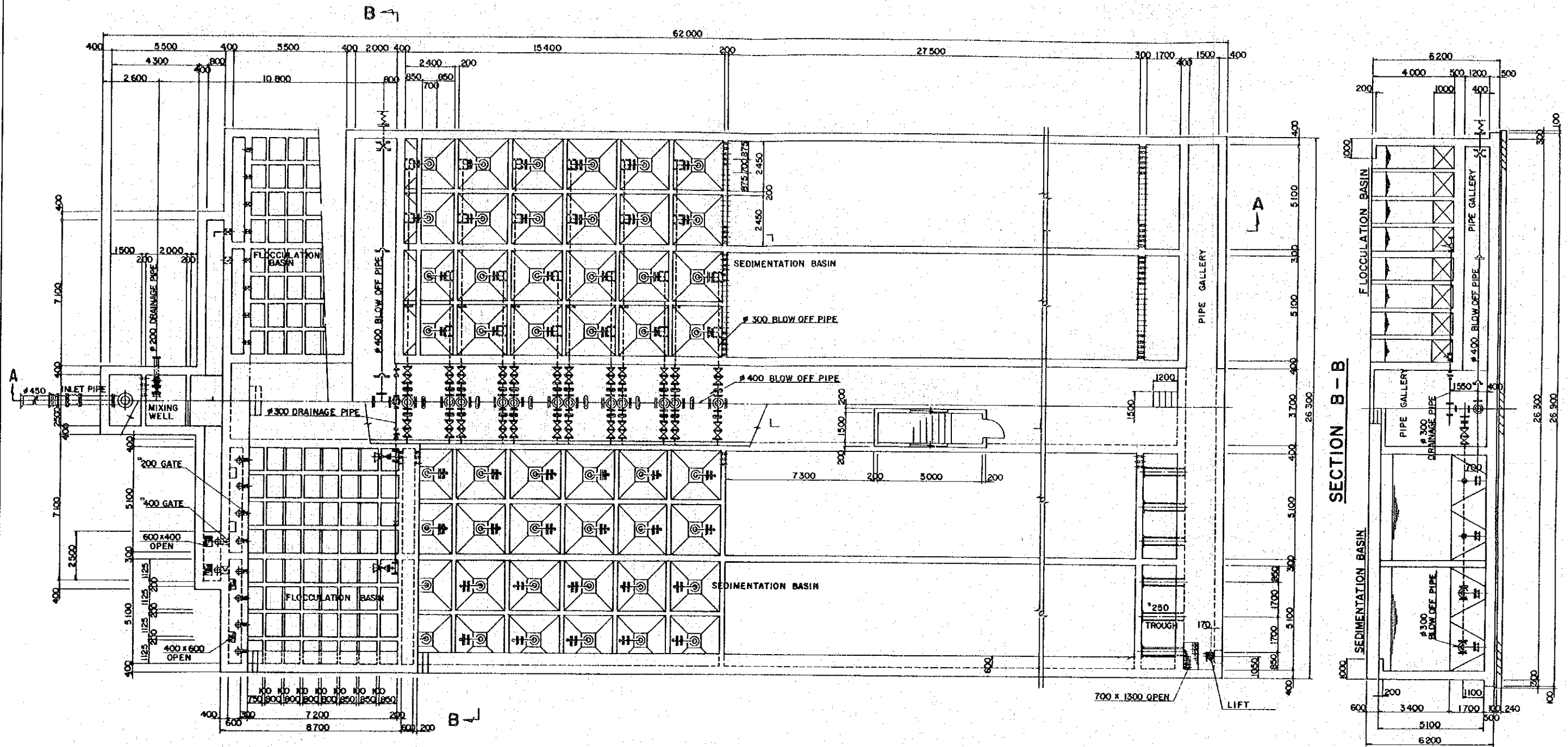

SECTION A-A

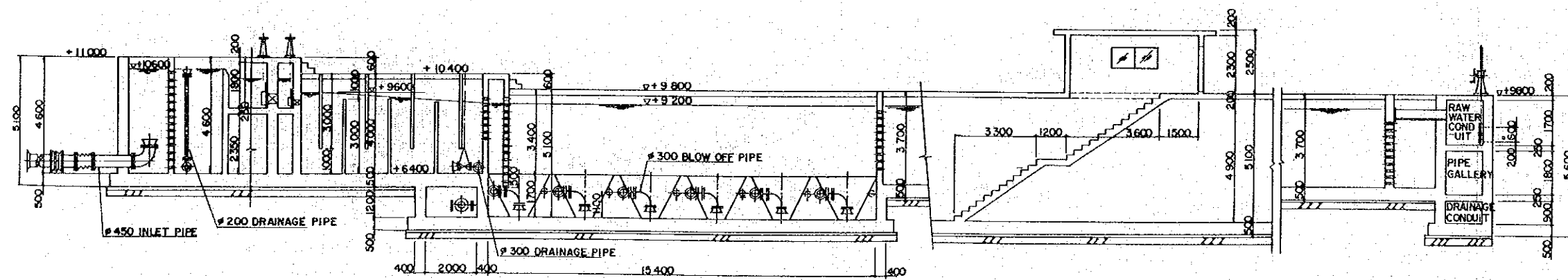

SECTION B-B

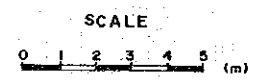
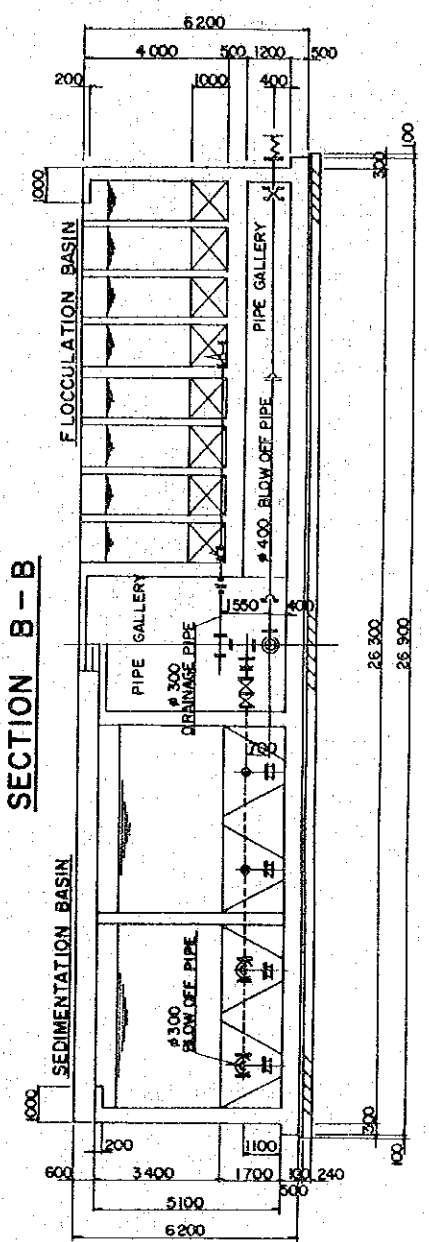

DIRECTORATE OF PUBLIC HEALTH ENGINEERING
GOVERNMENT OF BANGLADESH

NARAYANGANJ

**EAST PURIFICATION PLANT
FLOCCULATION BASIN & SEDIMENTATION BASIN PLAN & SECTIONS**

Date	Dec. 1984	Drawing No	10
------	-----------	------------	----

JAPAN INTERNATIONAL COOPERATION AGENCY

PLAN

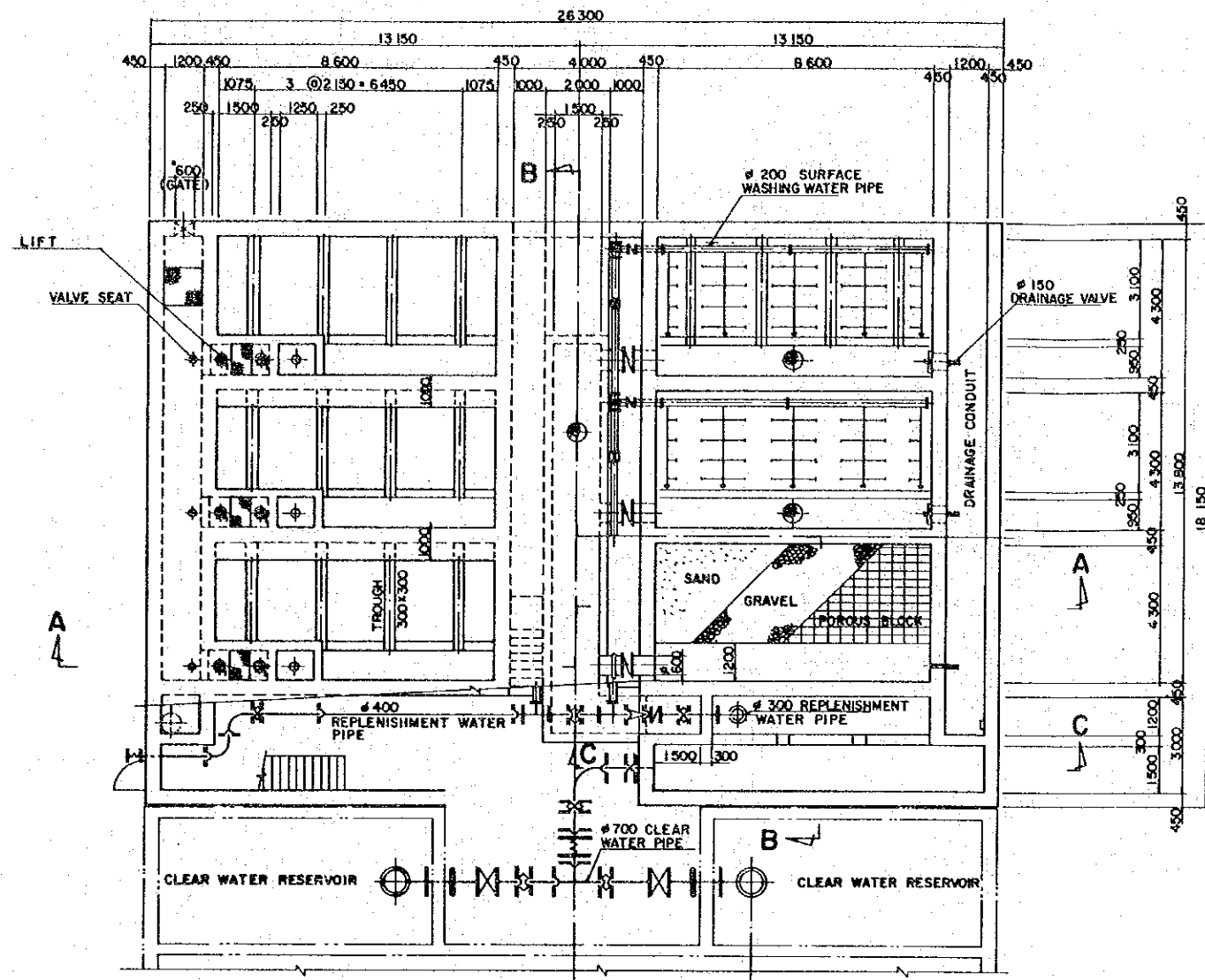

SECTION A-A

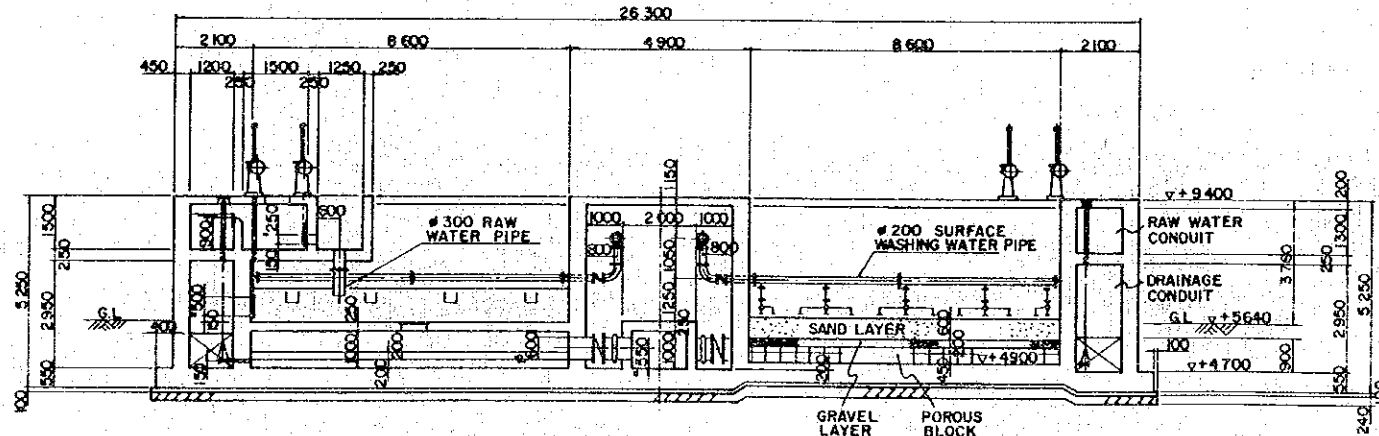

S = 1/100

SECTION B-B

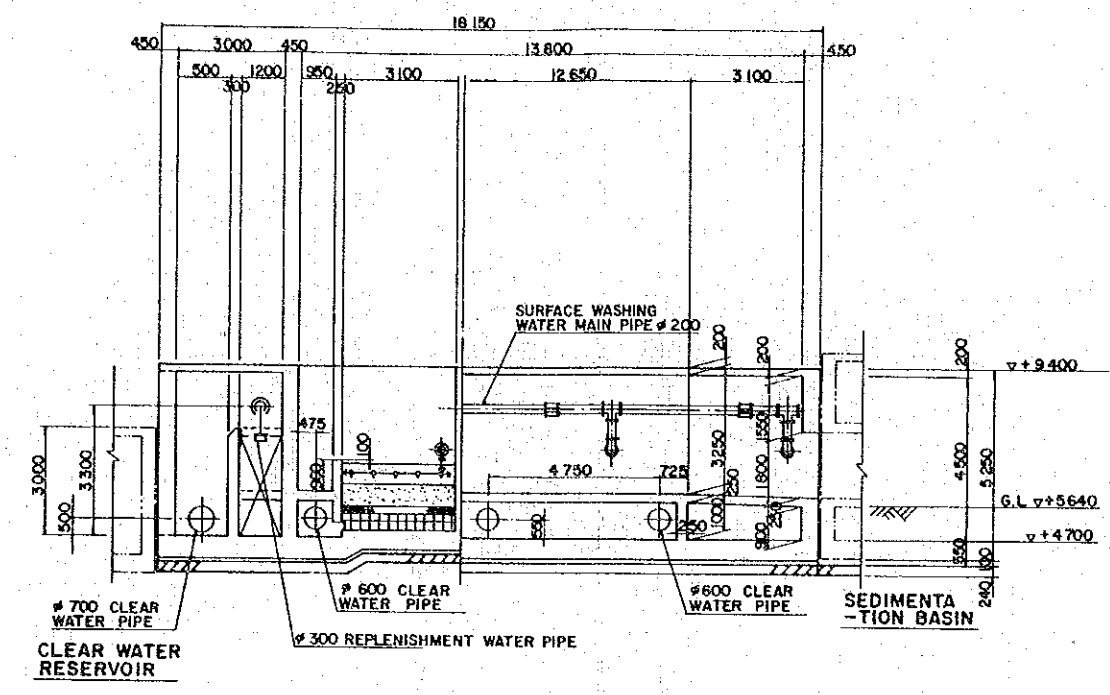

SECTION C-C

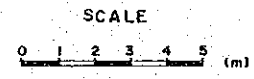
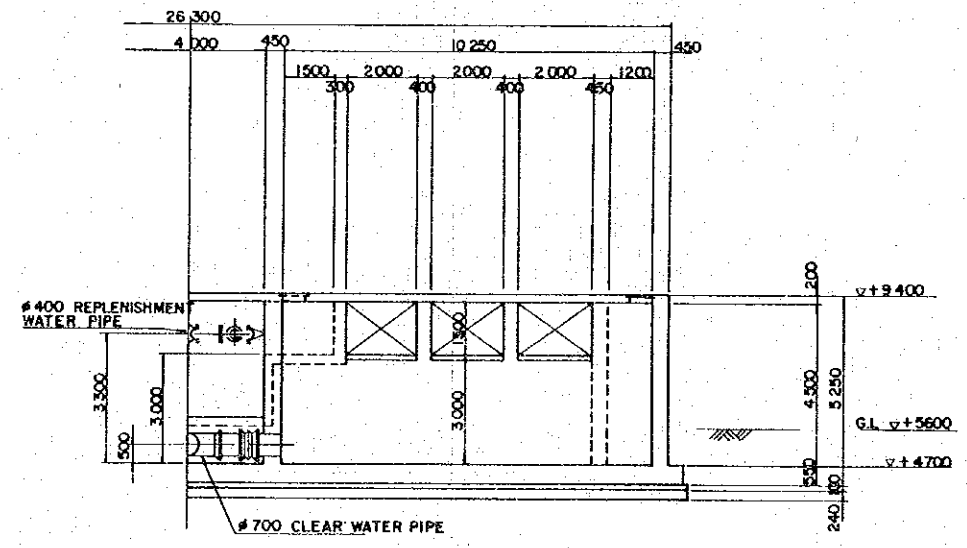

DIRECTORATE OF PUBLIC HEALTH ENGINEERING
GOVERNMENT OF BANGLADESH

NARAYANGANJ

**EAST PURIFICATION PLANT
RAPID SAND FILTER
PLAN AND SECTIONS**

Date	Dec. 1984	Drawing No	11
------	-----------	------------	----

JAPAN INTERNATIONAL COOPERATION AGENCY

PLAN

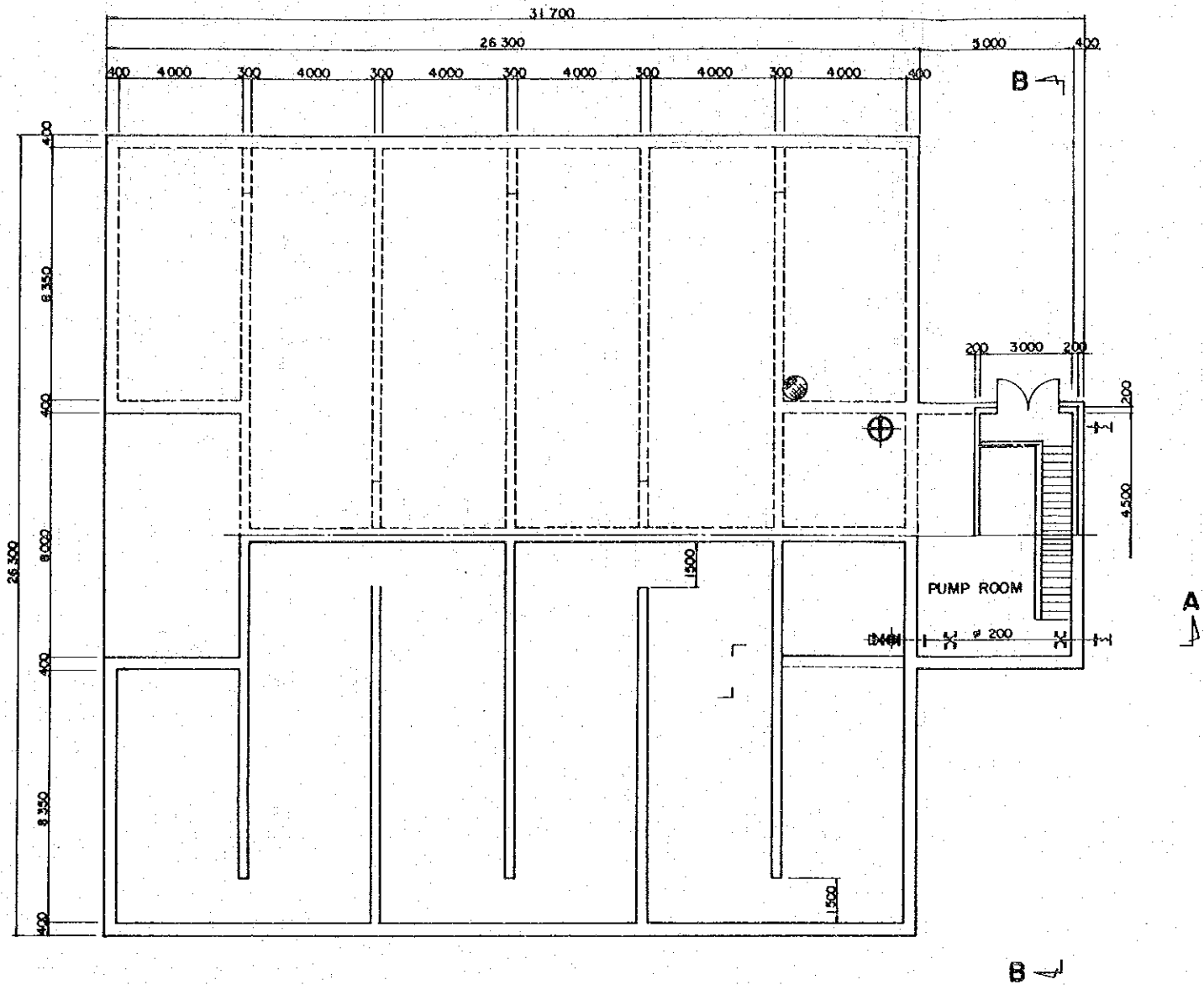

SECTION A-A

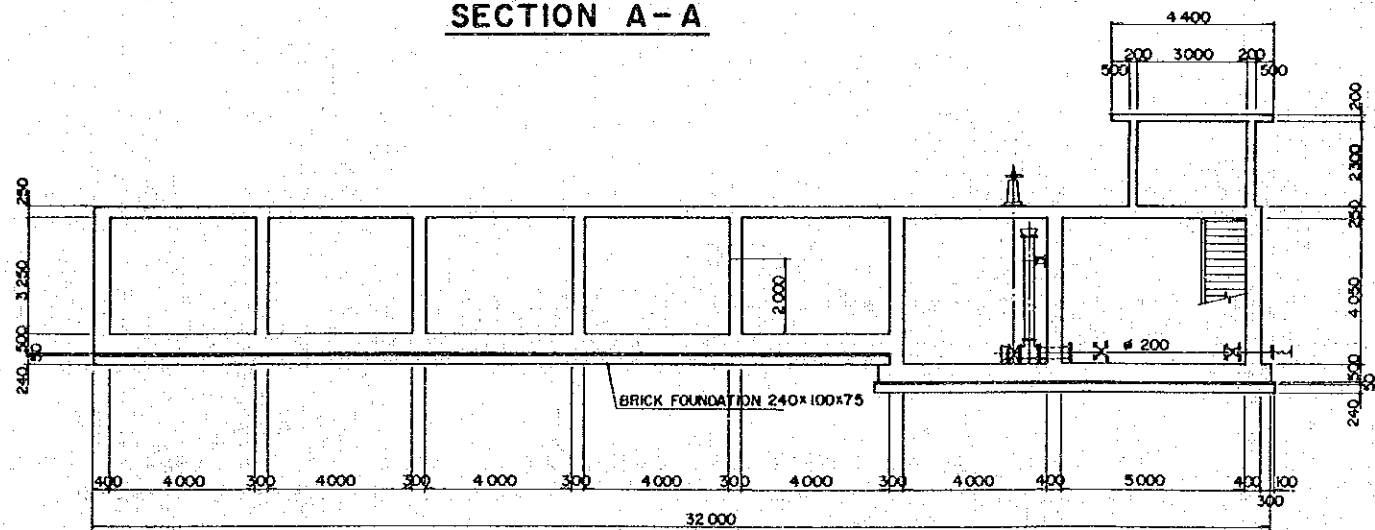

SECTION B-B

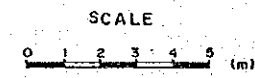
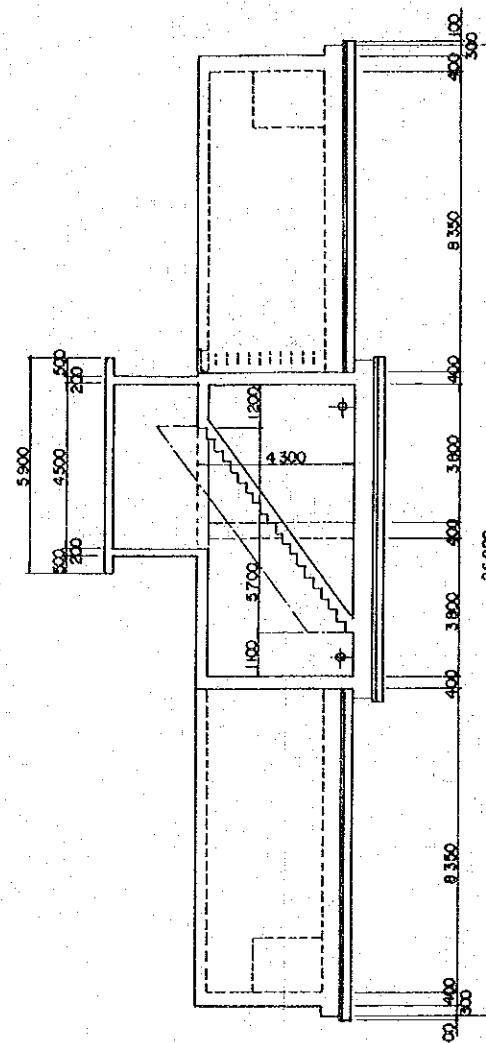

DIRECTORATE OF PUBLIC HEALTH ENGINEERING GOVERNMENT OF BANGLADESH			
NARAYANGANJ			
EAST PURIFICATION PLANT CLEAR WATER RESERVOIR PLAN AND SECTIONS			
Date	Dec. 1984	Drawing No	12
JAPAN INTERNATIONAL COOPERATION AGENCY			

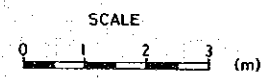
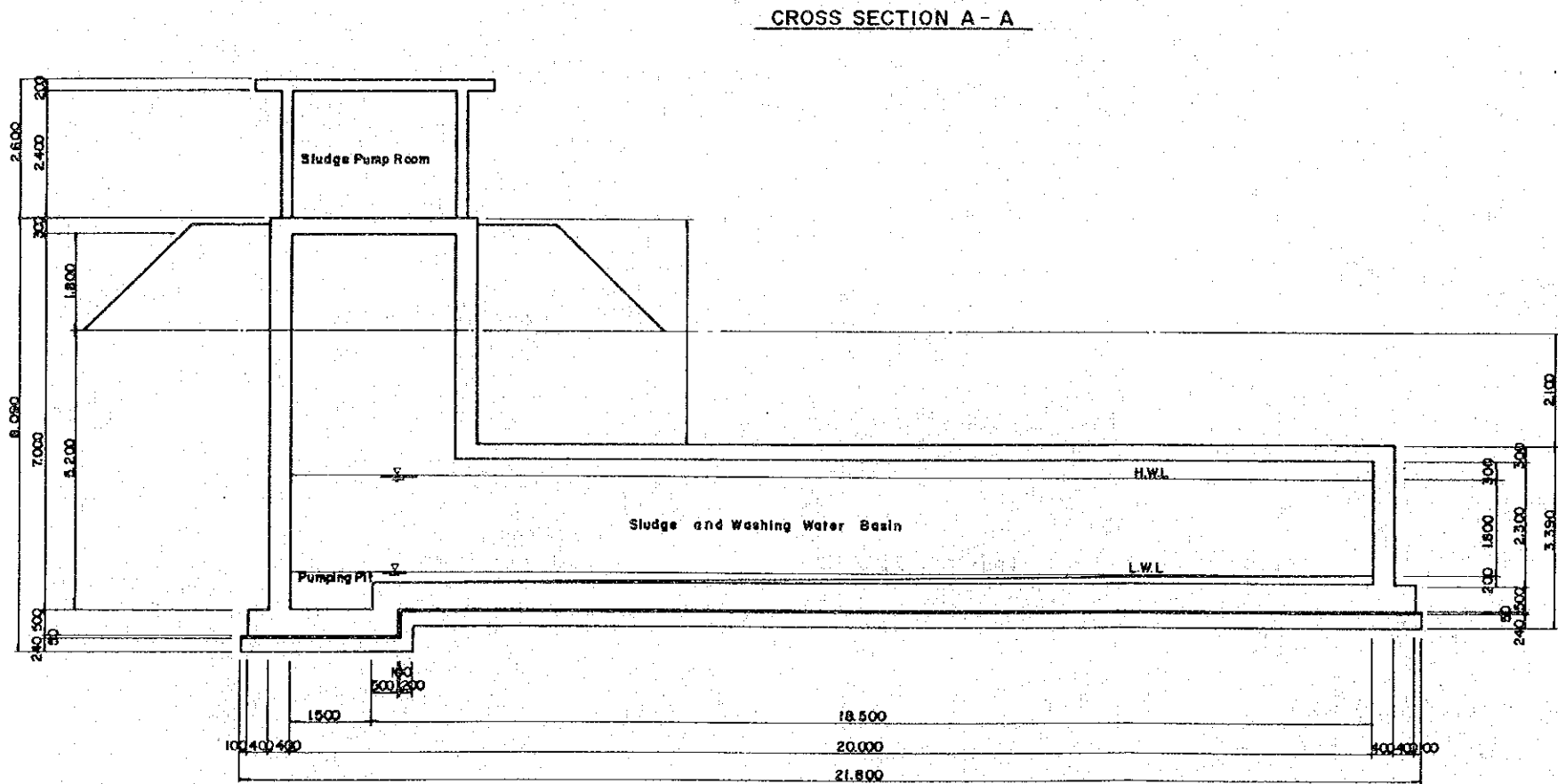
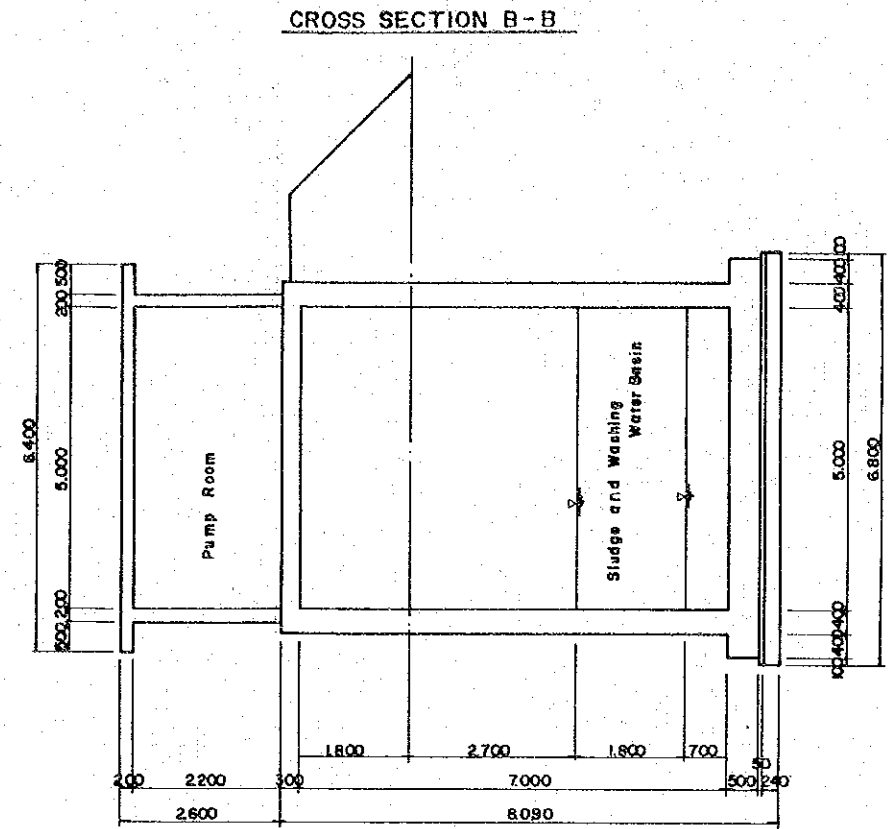
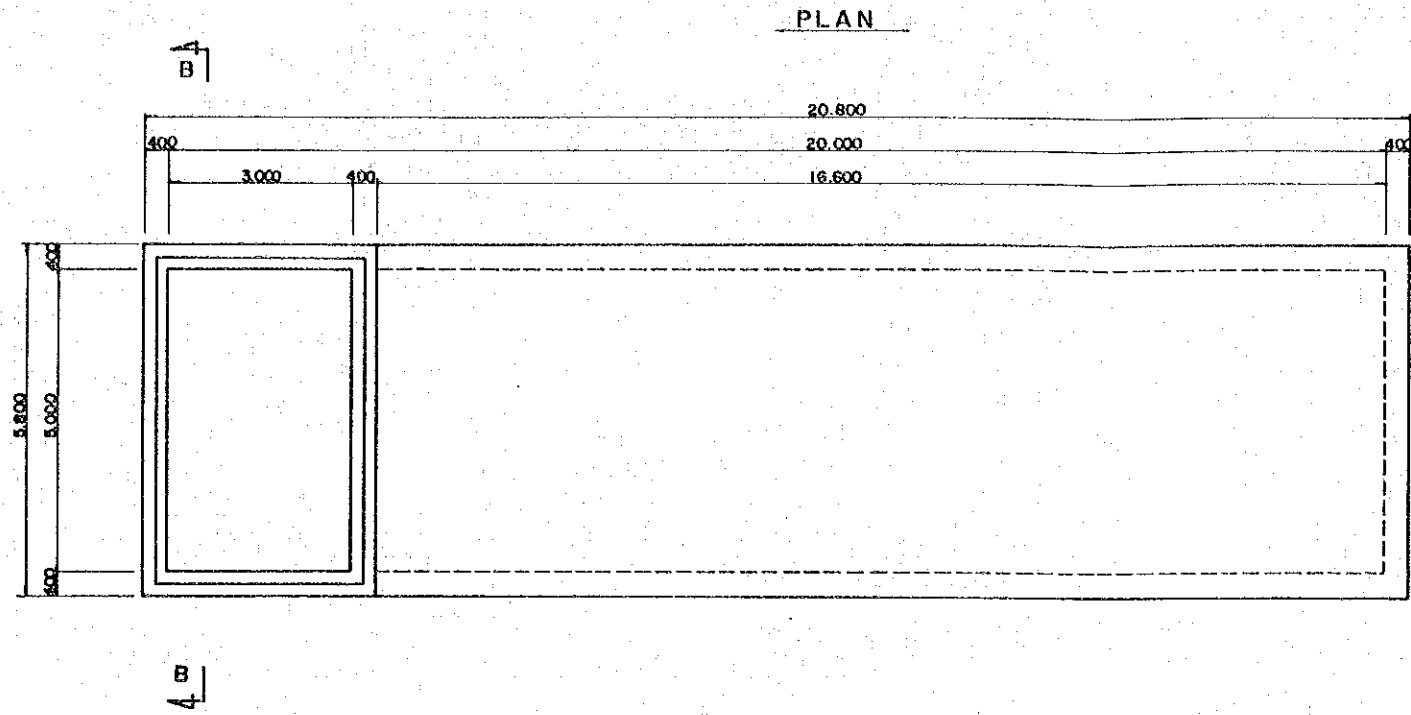

DIRECTORATE OF PUBLIC HEALTH ENGINEERING GOVERNMENT OF BANGLADESH			
NARAYANGANJ			
EAST PURIFICATION PLANT SLUDGE, WASHING WATER BASIN			
Date	Dec. 1984	Drawing No.	14
JAPAN INTERNATIONAL COOPERATION AGENCY			

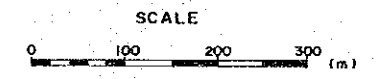
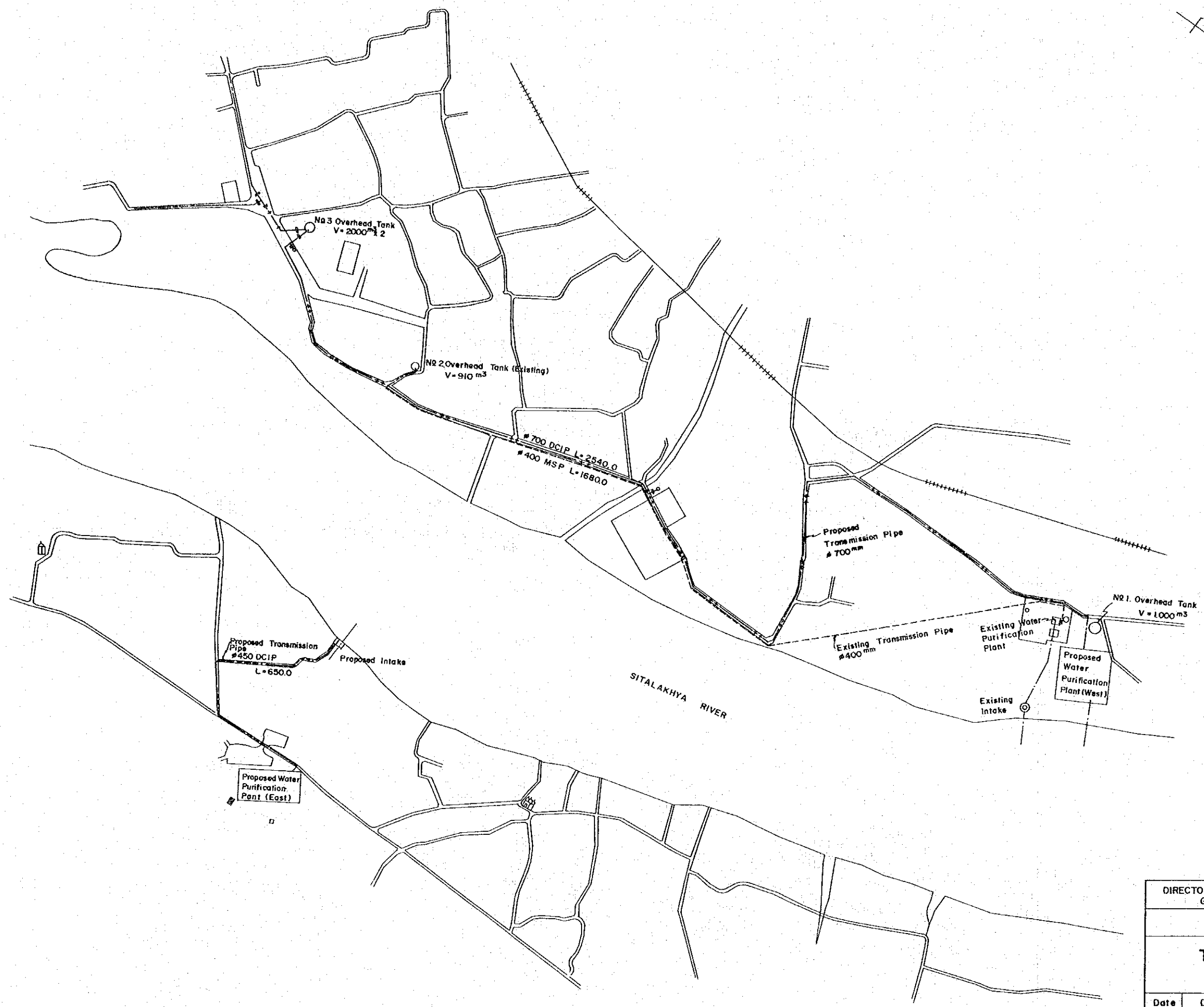
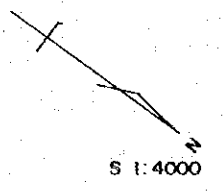

DIRECTORATE OF PUBLIC HEALTH ENGINEERING GOVERNMENT OF BANGLADESH			
NARAYANGANJ			
TRANSMISSION PIPES PLAN			
Date	Dec. 1984	Drawing No	15
JAPAN INTERNATIONAL COOPERATION AGENCY			

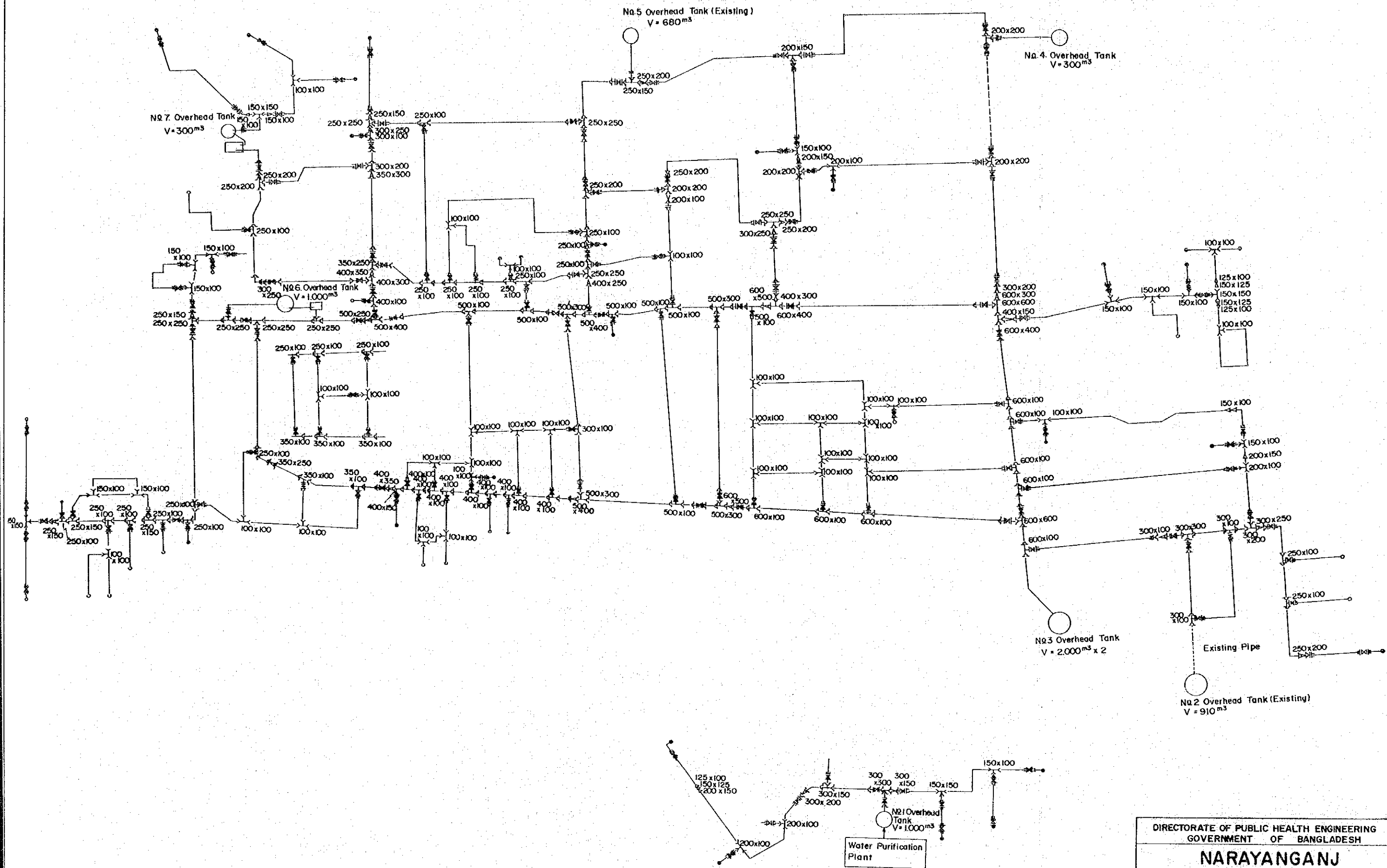

DIRECTORATE OF PUBLIC HEALTH ENGINEERING GOVERNMENT OF BANGLADESH			
NARAYANGANJ			
DISTRIBUTION PIPES DETAILED PLAN (I)			
(West Town)			
Date	Dec. 1984	Drawing No	16
JAPAN INTERNATIONAL COOPERATION AGENCY			

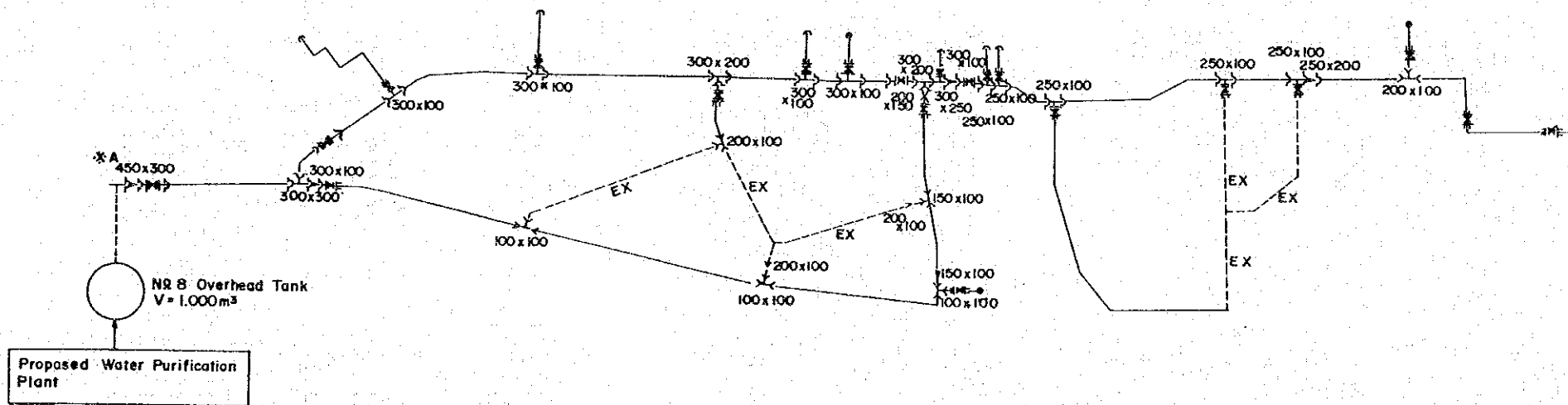
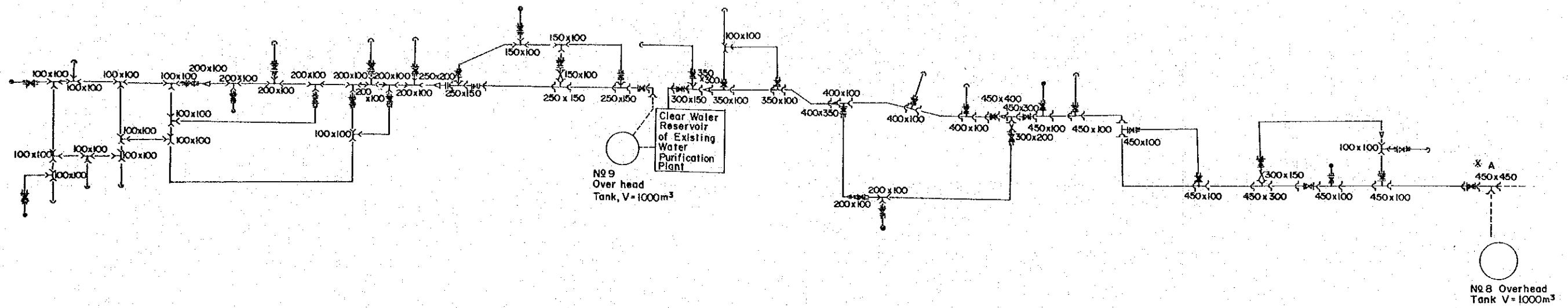

DIRECTORATE OF PUBLIC HEALTH ENGINEERING GOVERNMENT OF BANGLADESH			
NARAYANGANJ			
DISTRIBUTION PIPES DETAILED PLAN (2) (West Town)			
Date	Dec. 1984	Drawing No	17
JAPAN INTERNATIONAL COOPERATION AGENCY			

ROAD CROSSING

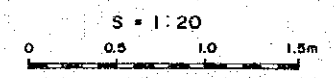
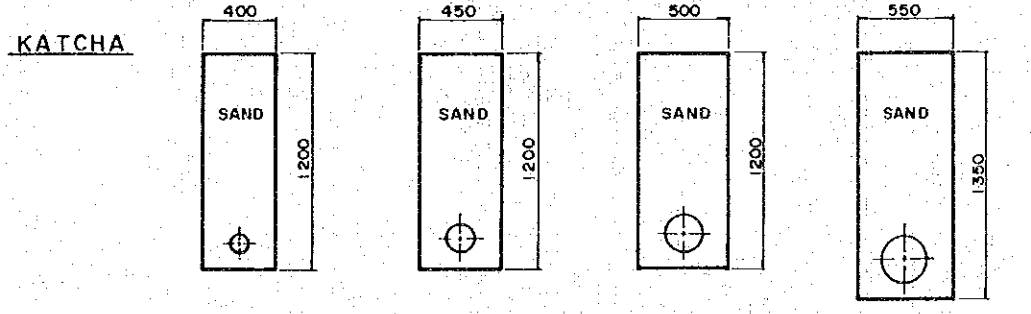
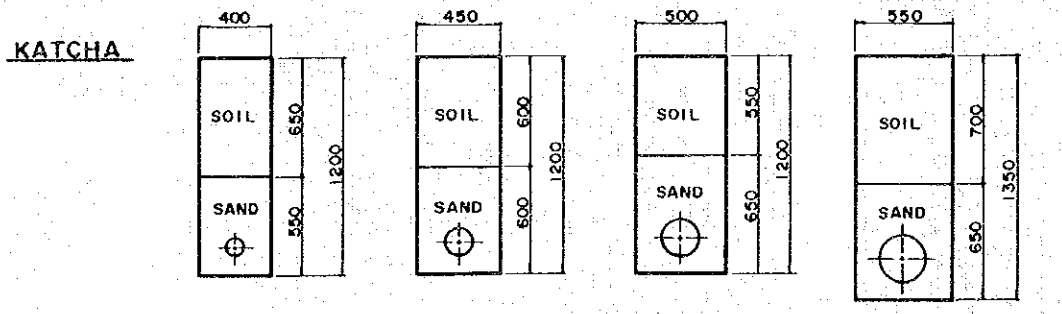
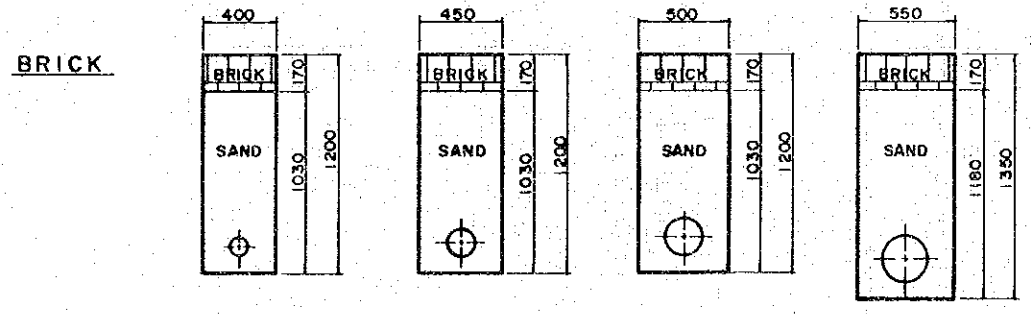
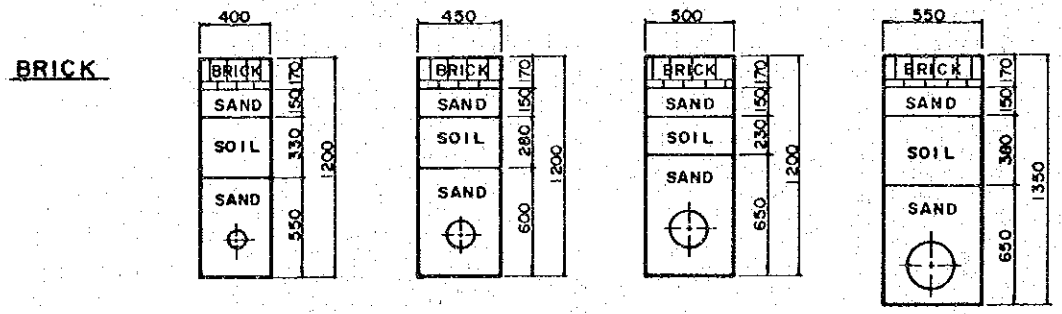
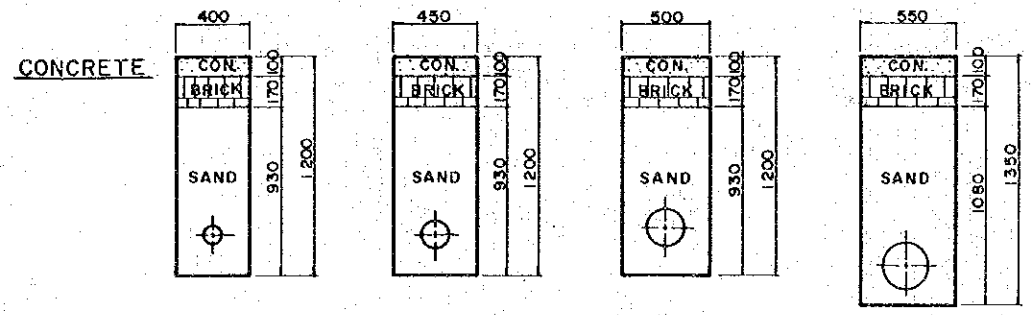
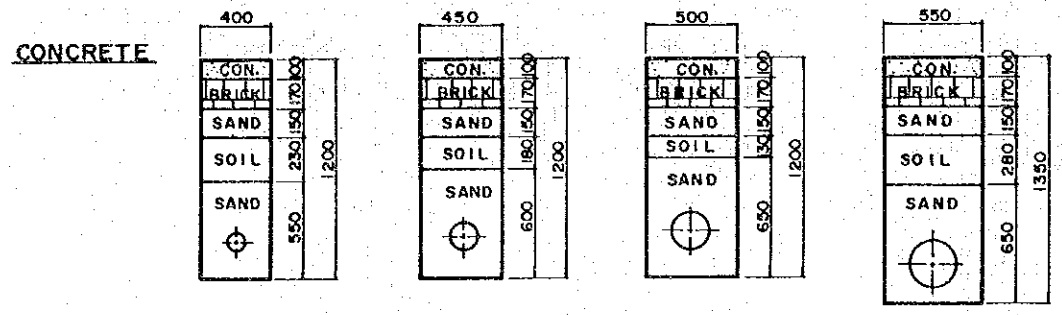
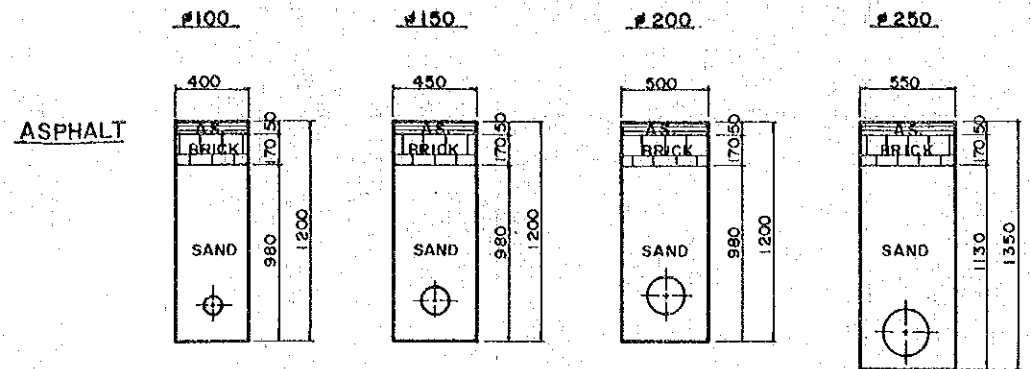
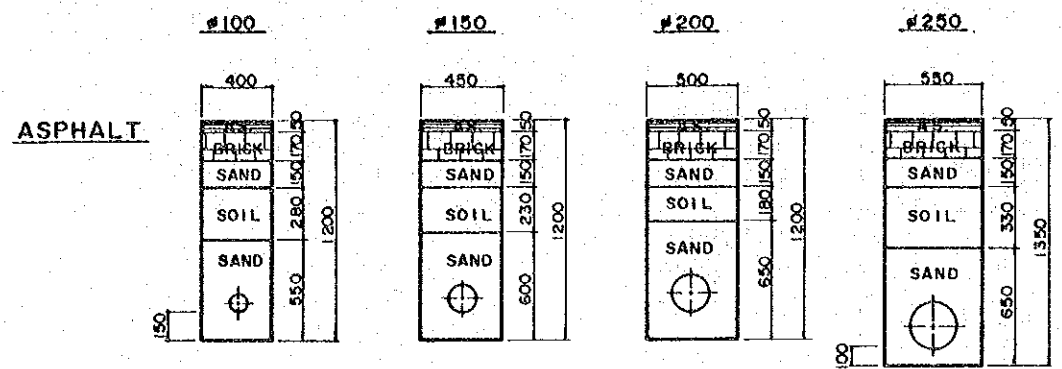

ROAD CROSSING

ASPHALT

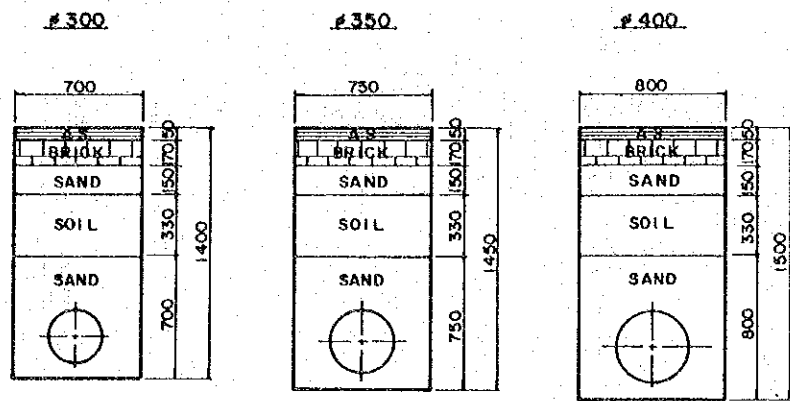

ASPHALT

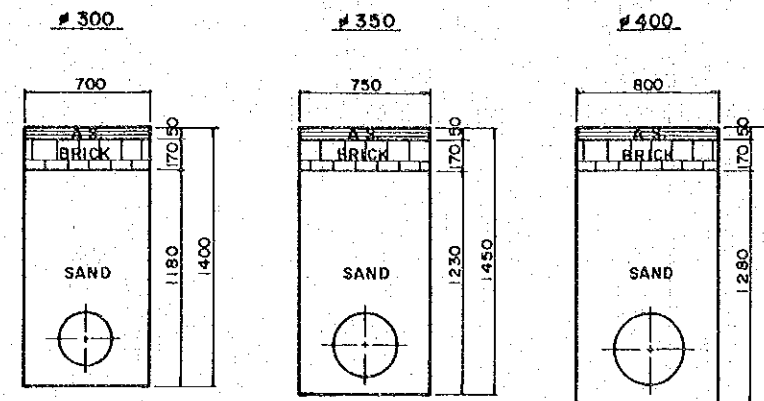

CONCRETE

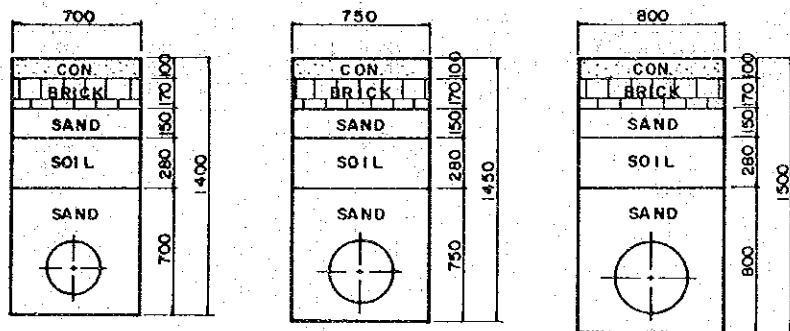

CONCRETE

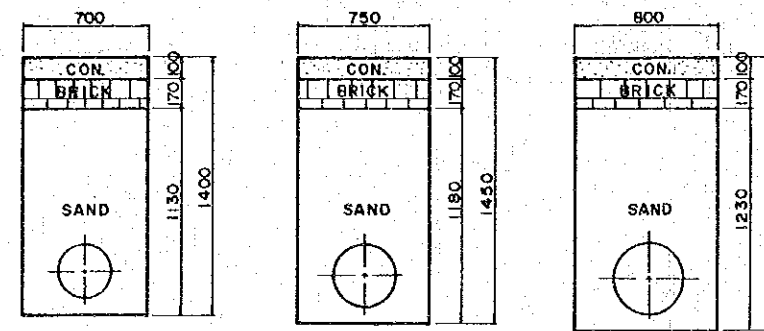

BRICK

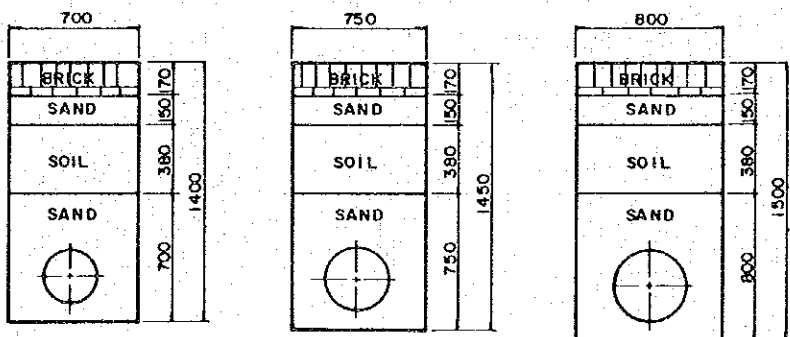

BRICK

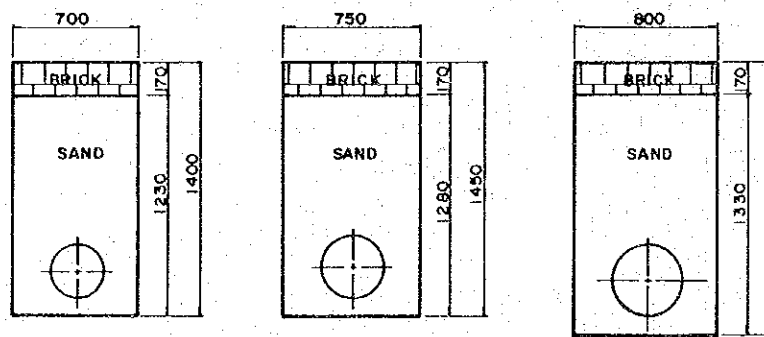

KATCHA

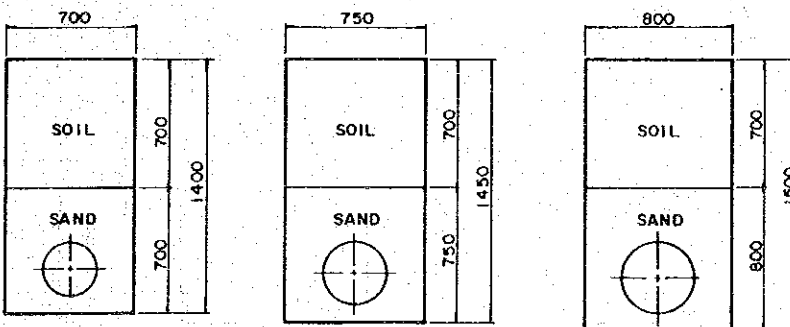

KATCHA

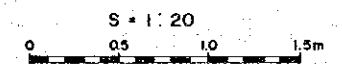
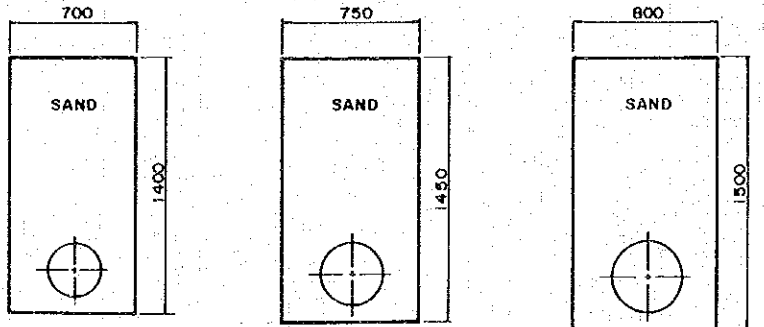

DIRECTORATE OF PUBLIC HEALTH ENGINEERING
GOVERNMENT OF BANGLADESH

LAYING DISTRIBUTION PIPE (2/3)
EXCAVATION AND REFILLING

Date Dec. 1984 Drawing No. 19
JAPAN INTERNATIONAL COOPERATION AGENCY

ROAD CROSSING

ASPHALT

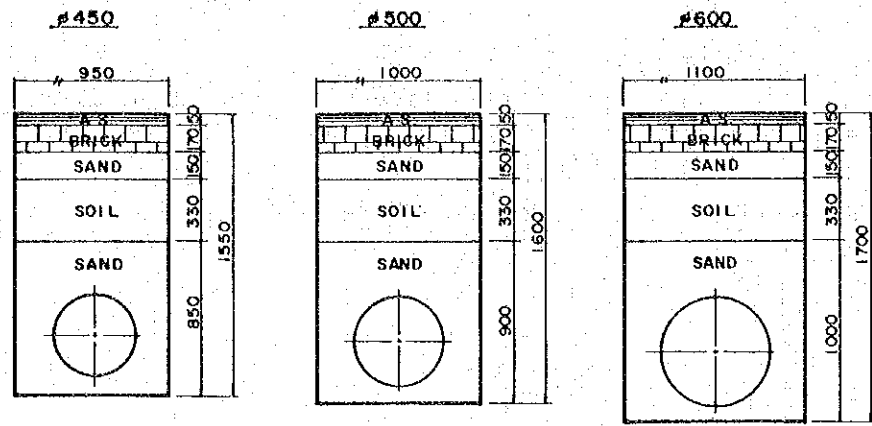

ASPHALT

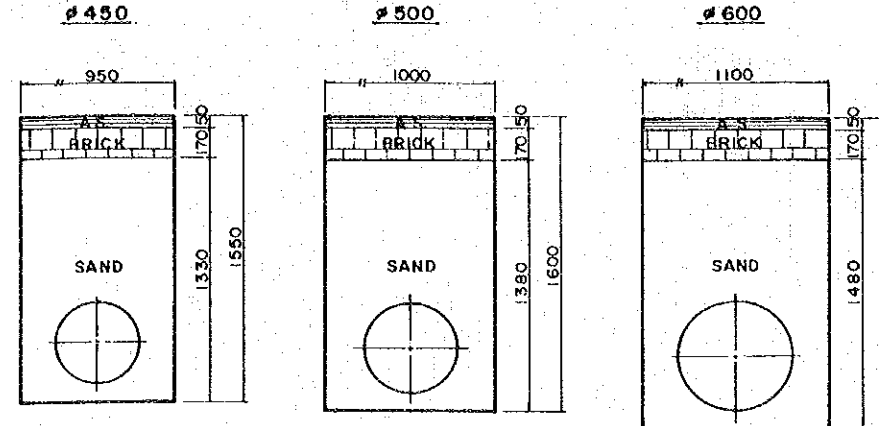

CONCRETE

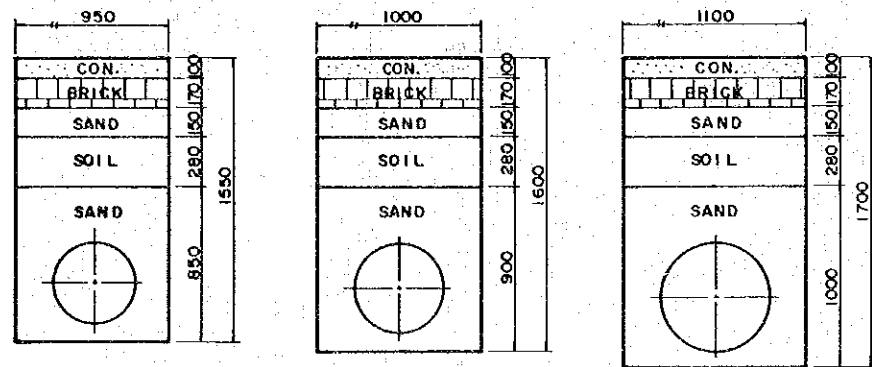

CONCRETE

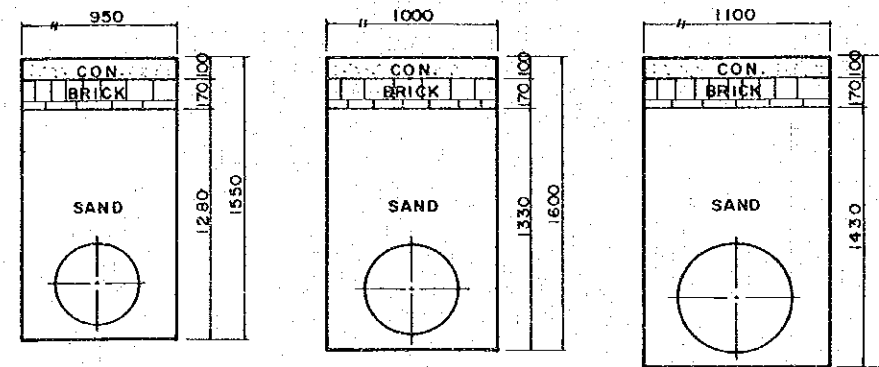

BRICK

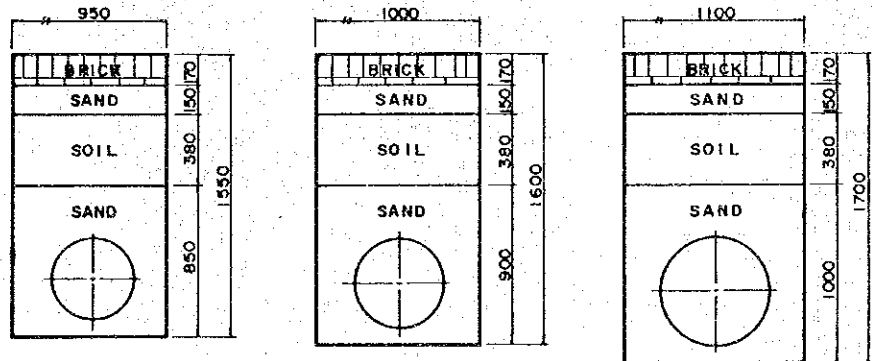

BRICK

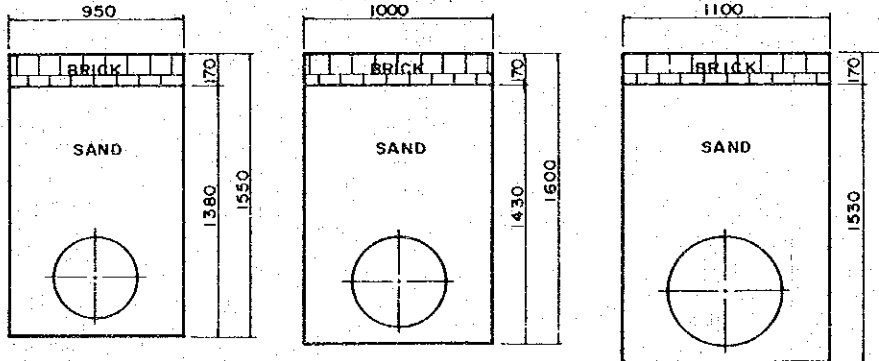

KATCHA

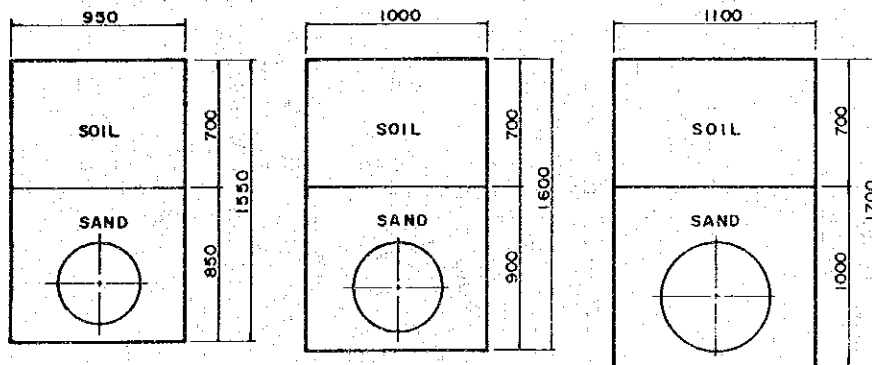

KATCHA

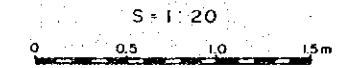
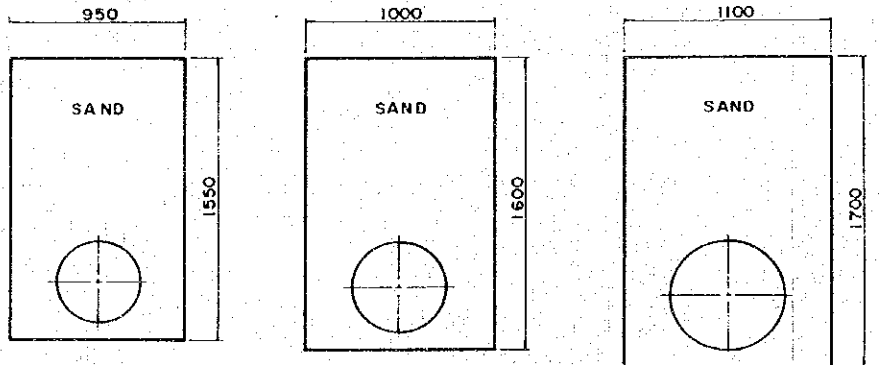

DIRECTORATE OF PUBLIC HEALTH ENGINEERING
GOVERNMENT OF BANGLADESH

LAYING DISTRIBUTION PIPE (3/3)
EXCAVATION AND REFILLING

Date Dec. 1984 Drawing No. 20
JAPAN INTERNATIONAL COOPERATION AGENCY

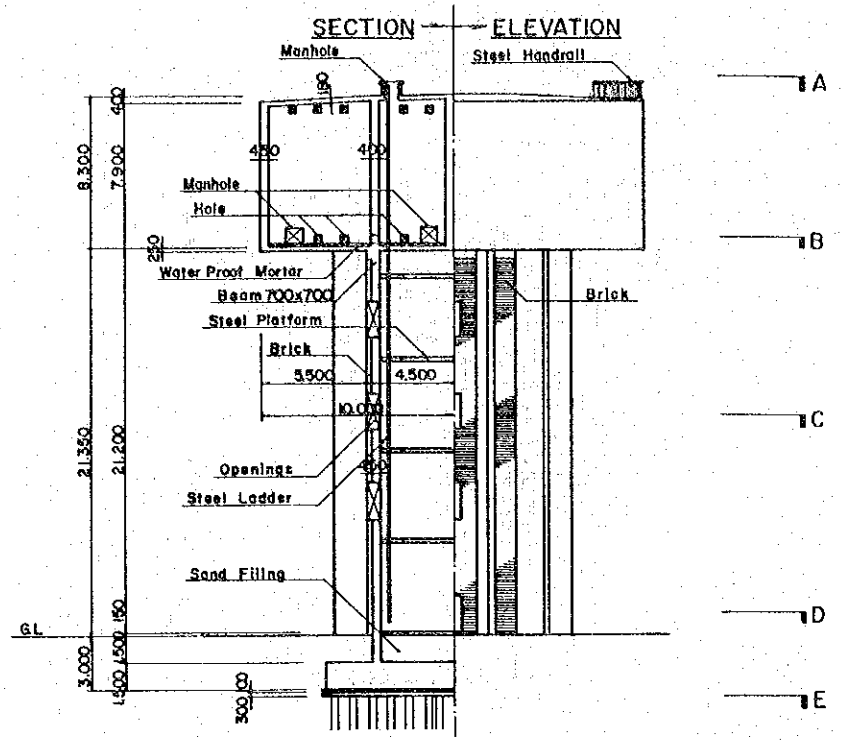

A - SECTION

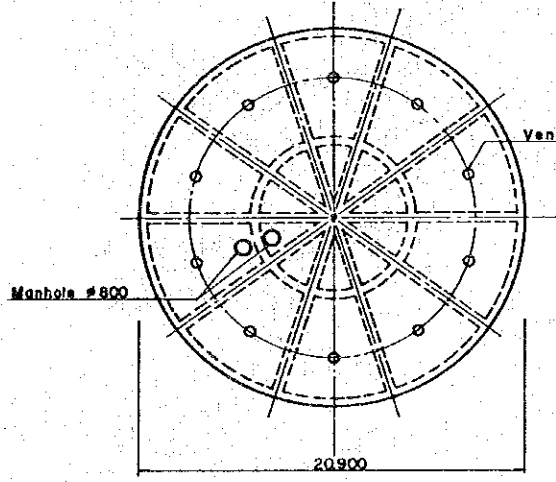

B - SECTION

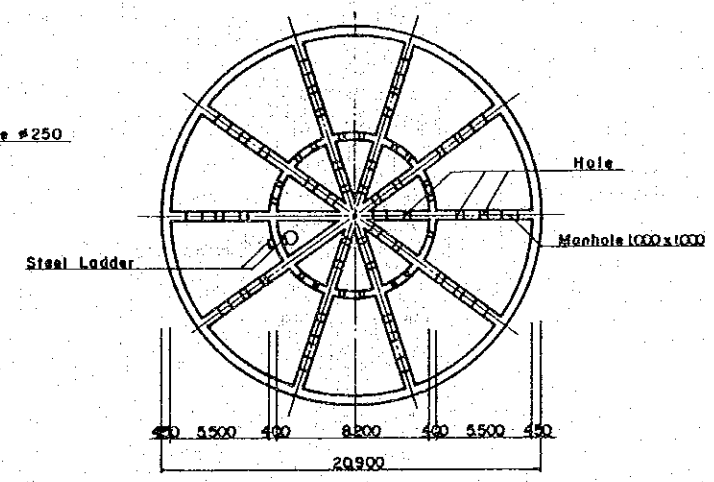

C - SECTION

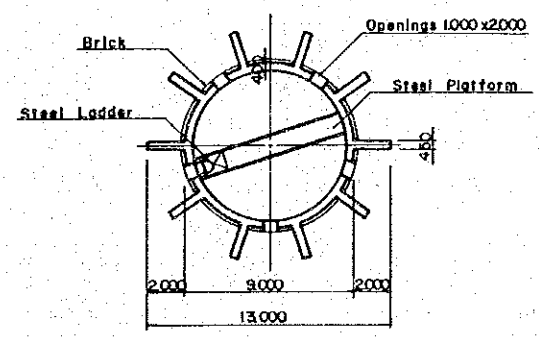

D - SECTION

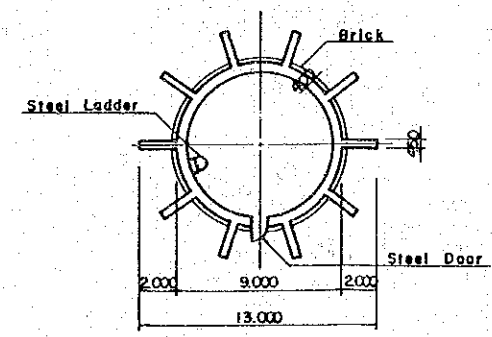

E - SECTION

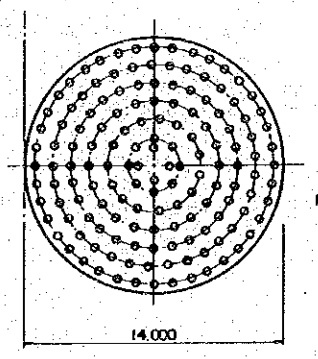

Pile: 148Nos.-400#(40T/P)
L=16,000 m

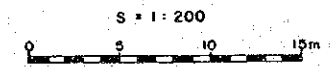

DIRECTORATE OF PUBLIC HEALTH ENGINEERING GOVERNMENT OF BANGLADESH			
NARAYANGANJ			
OVERHEAD TANK (2,000m³) SECTION AND ELEVATION			
Date	Dec. 1984	Drawing No.	21
JAPAN INTERNATIONAL COOPERATION AGENCY			

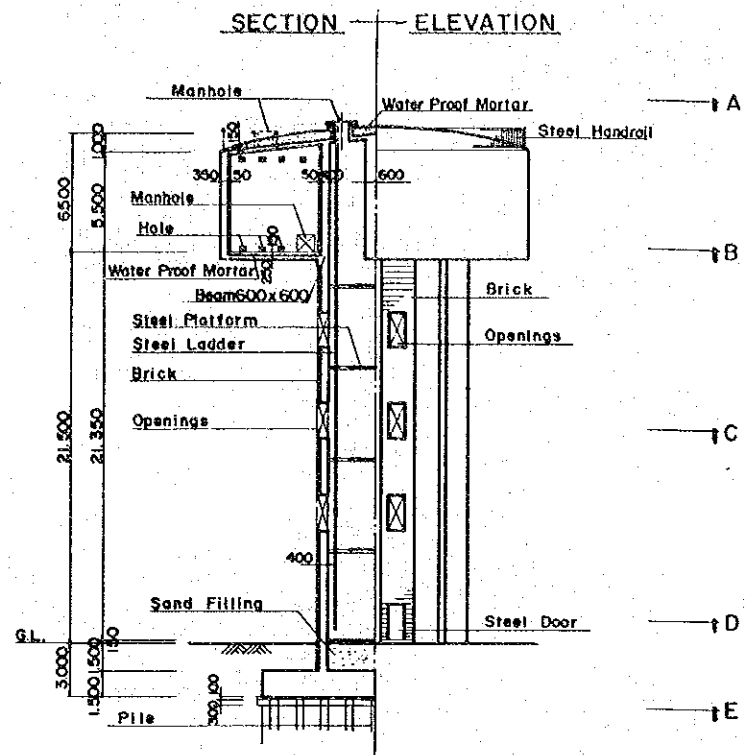

A - SECTION

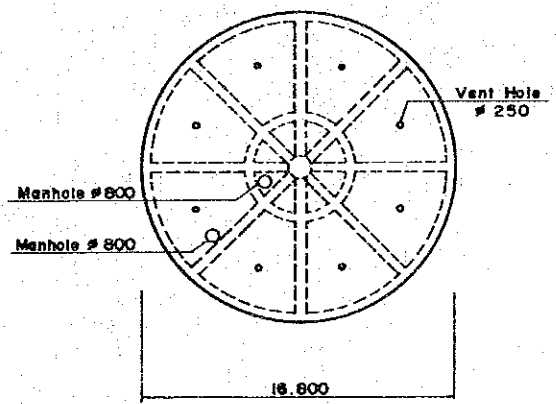

B - SECTION

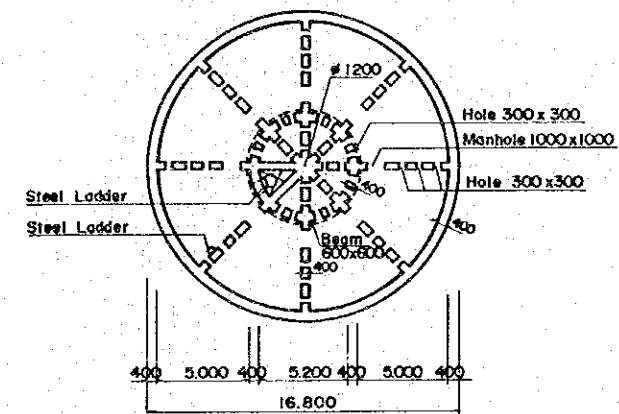

C - SECTION

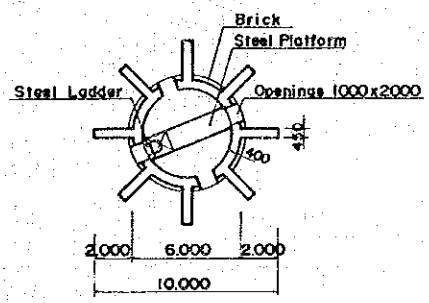

D - SECTION

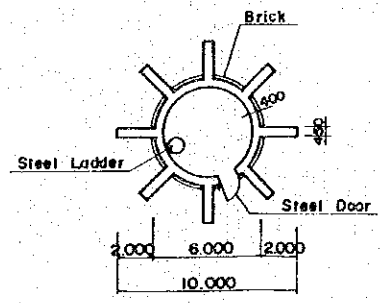

E - SECTION

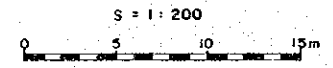
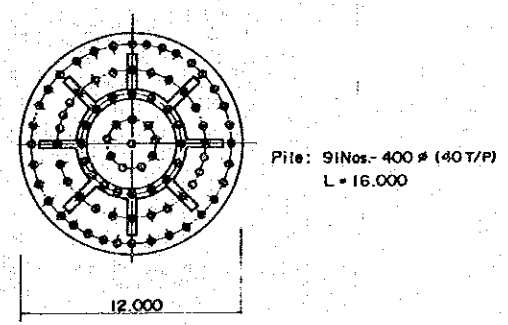

DIRECTORATE OF PUBLIC HEALTH ENGINEERING GOVERNMENT OF BANGLADESH			
NARAYANGANJ			
OVERHEAD TANK (1,000m³) SECTION AND ELEVATION			
Date	Dec. 1984	Drawing No.	22
JAPAN INTERNATIONAL COOPERATION AGENCY			

200m³ OVERHEAD TANK

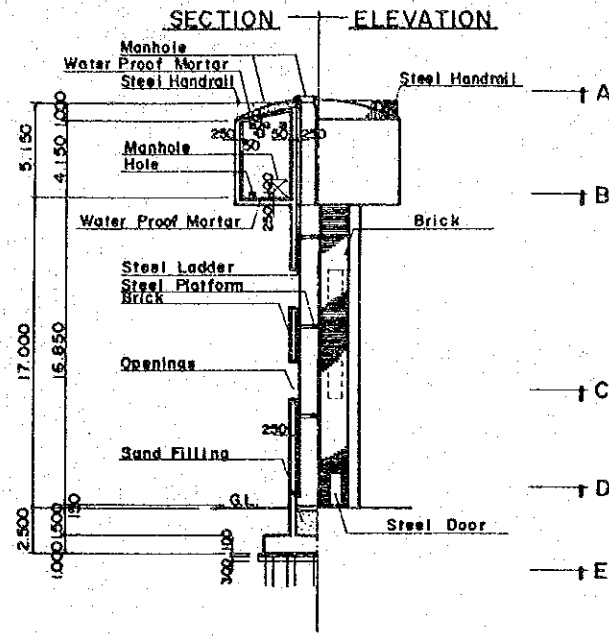

A-SECTION

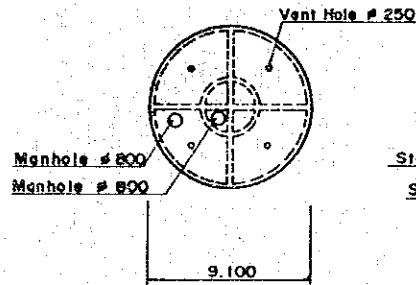

B-SECTION

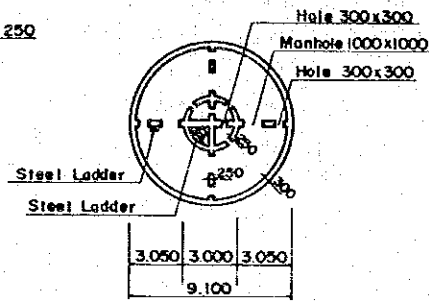

C-SECTION

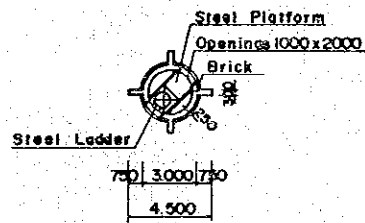

D-SECTION

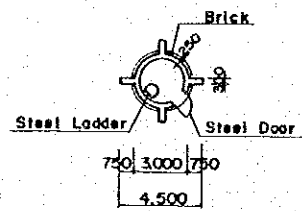

E-SECTION

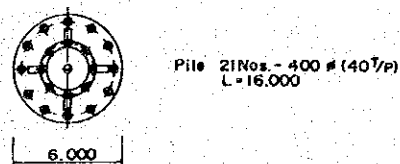

300m³ OVERHEAD TANK

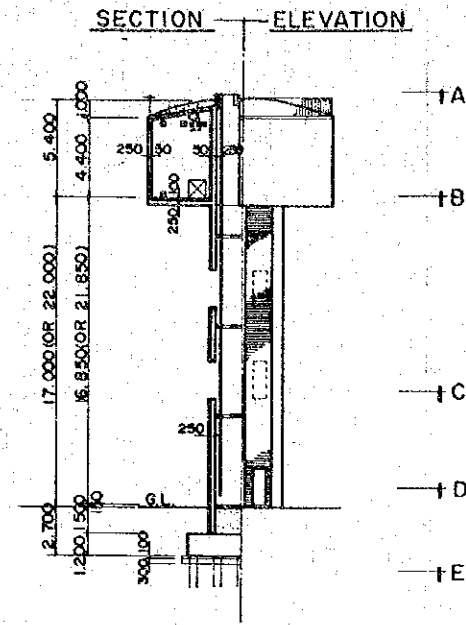

A-SECTION



B-SECTION

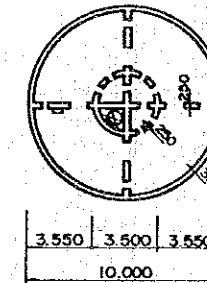

C-SECTION

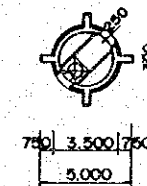

D-SECTION

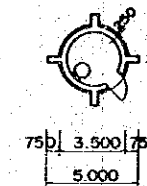

E-SECTION

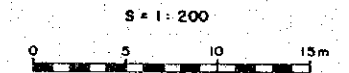
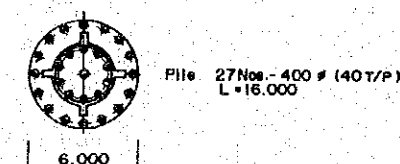

DIRECTORATE OF PUBLIC HEALTH ENGINEERING
GOVERNMENT OF BANGLADESH

OVERHEAD TANK (200m³, 300m³)
SECTION AND ELEVATION

Date	Dec. 1984	Drawing No.	23
JAPAN INTERNATIONAL COOPERATION AGENCY			

S 1:2000



SCALE
0 50 100 150 (m)

DIRECTORATE OF PUBLIC HEALTH ENGINEERING
GOVERNMENT OF BANGLADESH

NARAYANGANJ
RESERVOIRS OF NO 6 & NO 7
OVERHEAD TANK
LOCATION

Date	Dec. 1984	Drawing No	24
JAPAN INTERNATIONAL COOPERATION AGENCY			

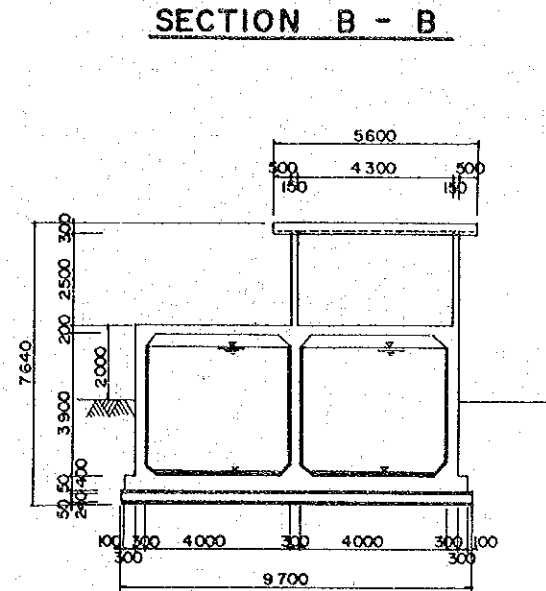
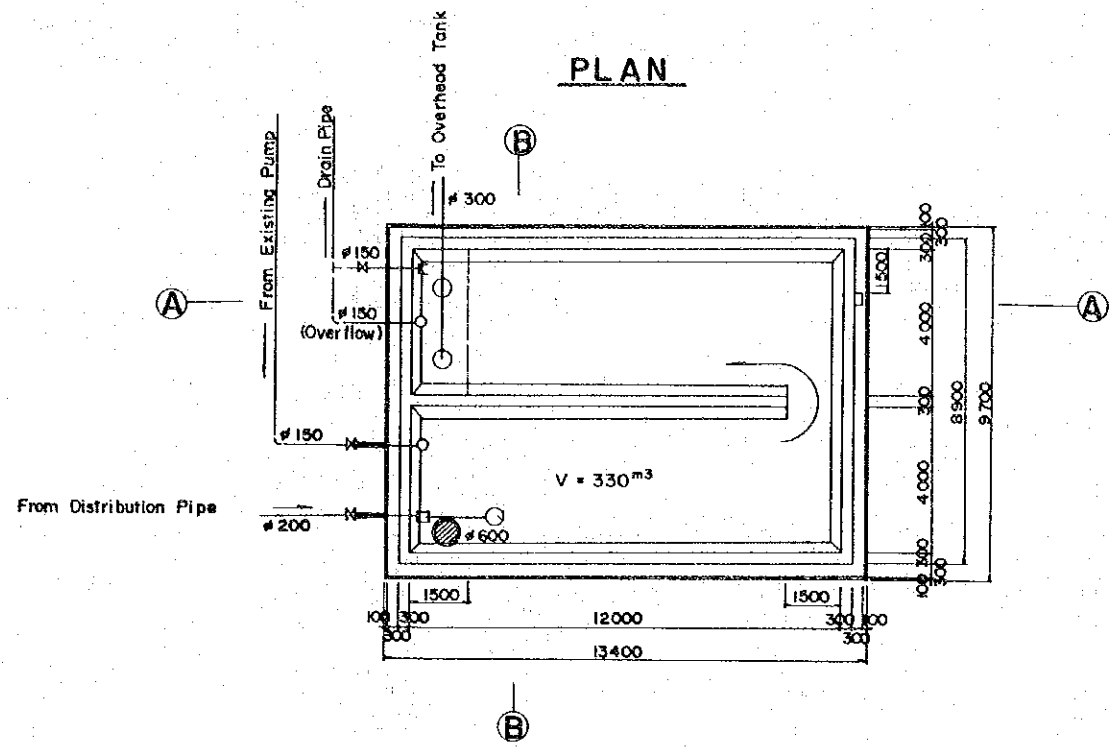

PLAN OF PUMP HOUSE SCALE 0 0.5 1.0 1.5 (m)

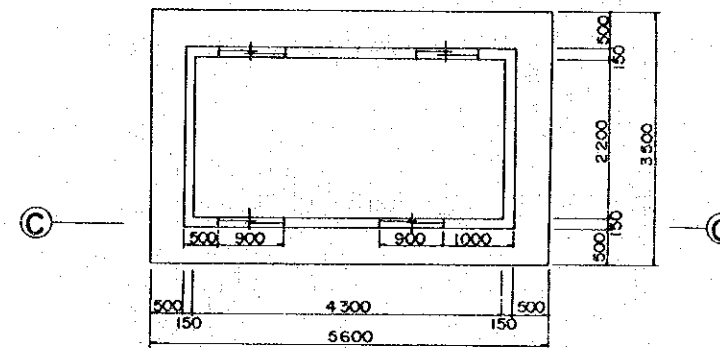

SECTION C - C SCALE 0 0.5 1.0 1.5 (m)

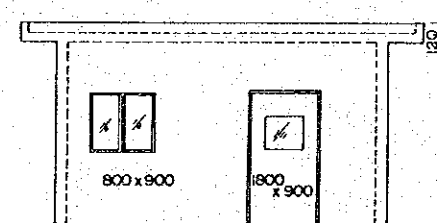

SECTION A - A

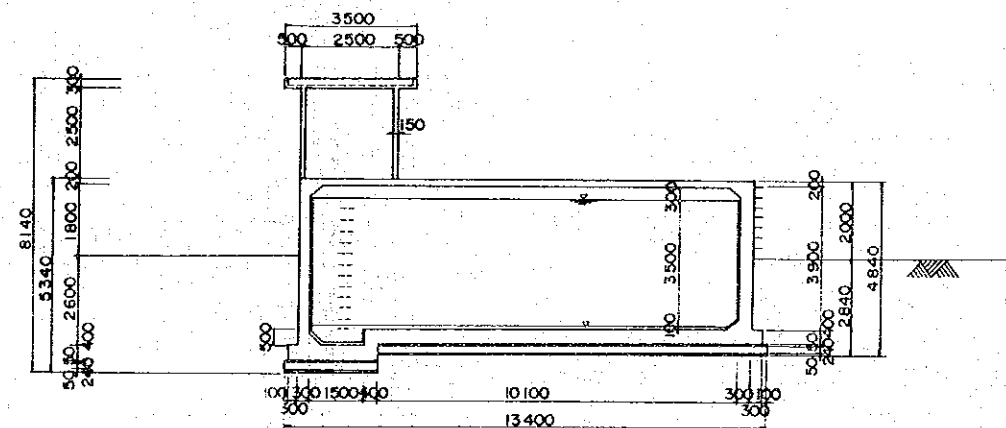

SCALE 0 1 2 3 4 5 (m)

DIRECTORATE OF PUBLIC HEALTH ENGINEERING GOVERNMENT OF BANGLADESH			
NARAYANGANJ			
RESERVOIR OF NO 6 OVERHEAD TANK PLAN AND SECTIONS			
Date	Dec. 1984	Drawing No	25
JAPAN INTERNATIONAL COOPERATION AGENCY			

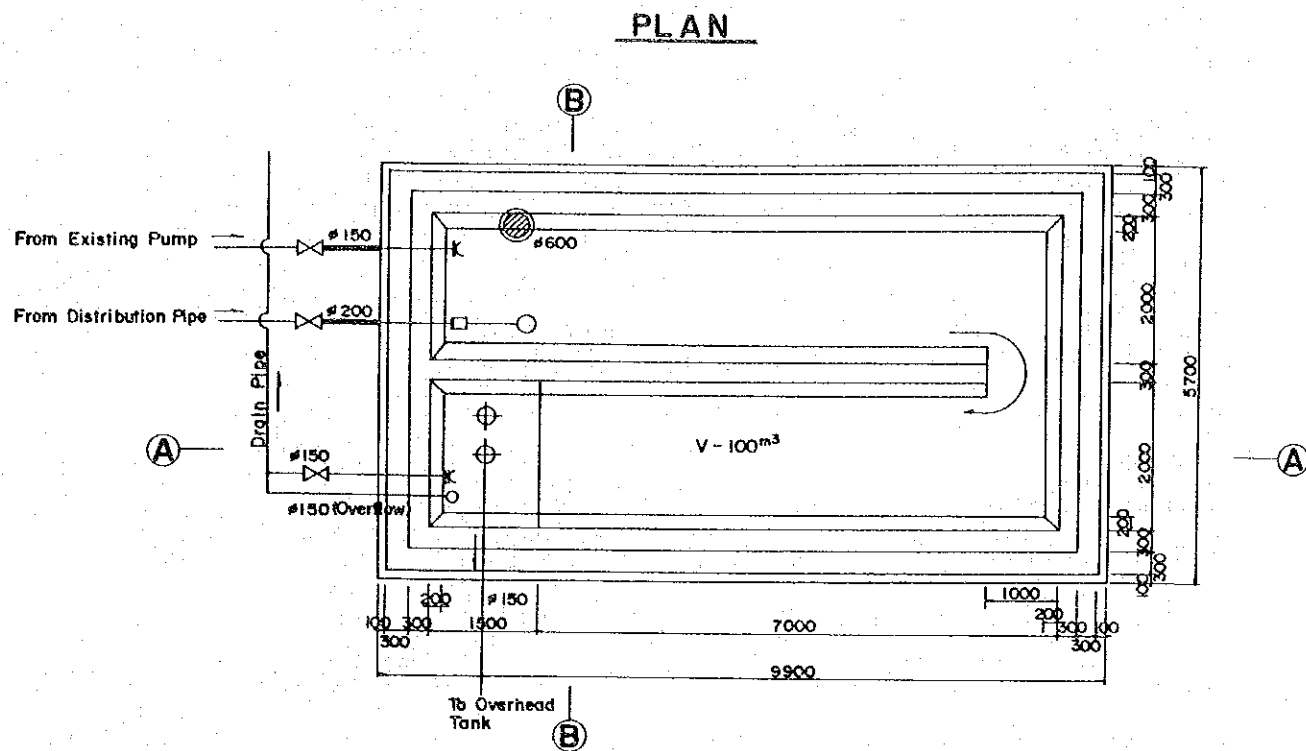

SECTION B - B

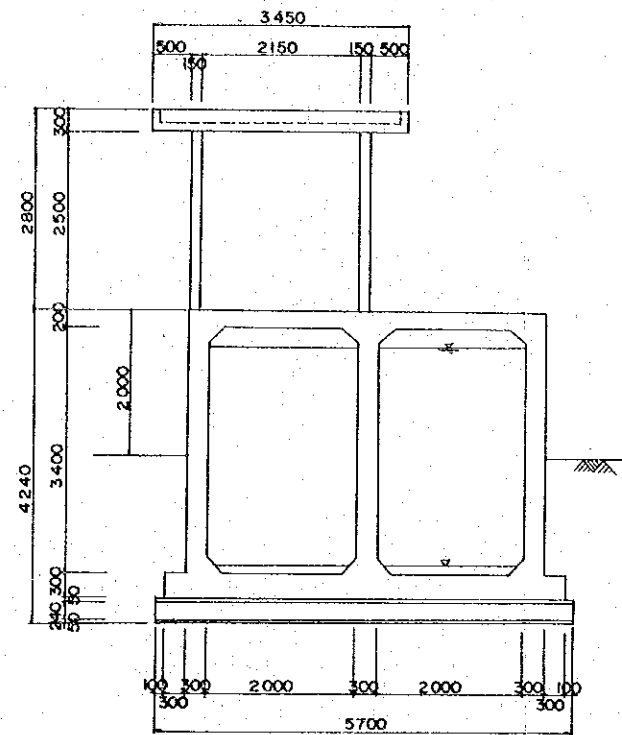

SECTION A - A

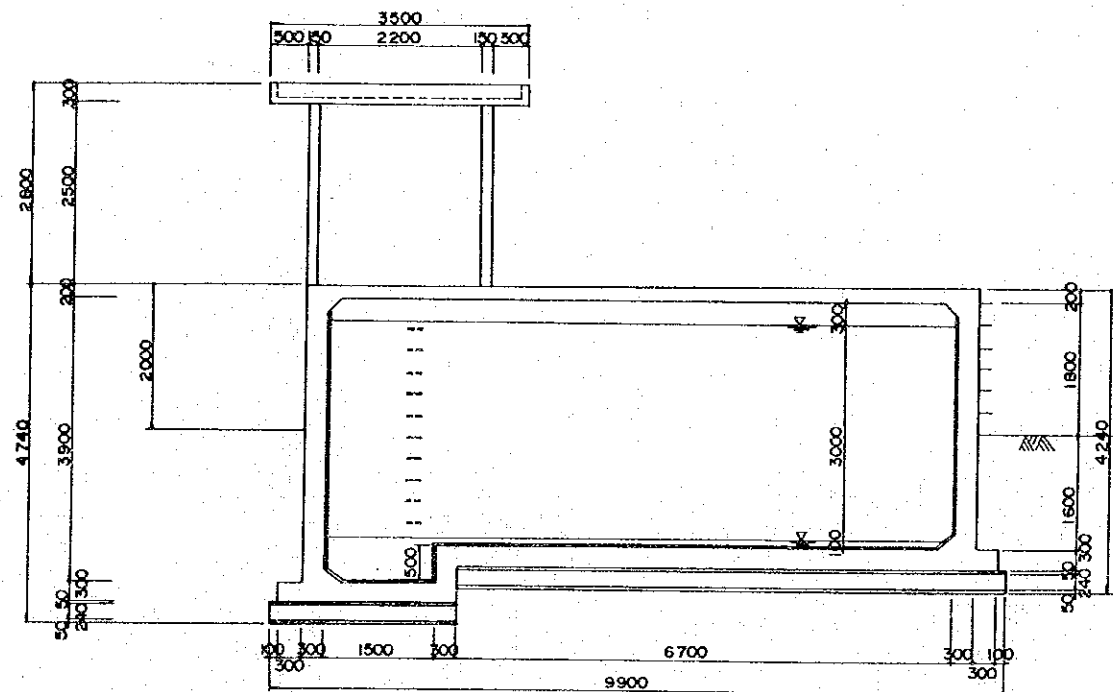

PLAN OF PUMP HOUSE

SCALE 0 0.5 1.0 1.5 (m)

SECTION C - C

SCALE 0 0.5 1.0 1.5 (m)

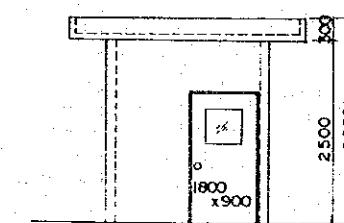
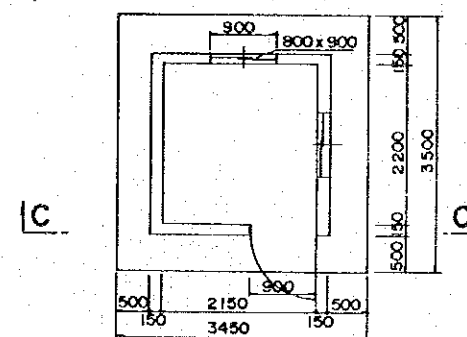

SCALE 0 1 2 3 4 5 (m)

DIRECTORATE OF PUBLIC HEALTH ENGINEERING GOVERNMENT OF BANGLADESH			
NARAYANGANJ			
RESERVOIR OF NO 7 OVERHEAD TANK PLAN AND SECTIONS			
Date	Dec. 1984	Drawing No	26
JAPAN INTERNATIONAL COOPERATION AGENCY			

JICA