

フィリピン共和国

地方道路橋梁建設計画(フェーズI)

基本設計調査報告書

(図面編)

昭和63年1月

国際協力事業団

118
61.5
GRS

無計三

88-9

フィリピン共和国

地方道路橋梁建設計画(フェーズⅠ)

基本設計調査報告書

(図面編)

JICA LIBRARY



1041349[0]

昭和63年1月

国際協力事業団

国際協力事業団	
受入 月日 '88. 2. 24	118
登録No. 17207	61.5
	GRS

目 次

図面タイトル	図面番号
要請橋梁位置図 -----	1
全要請橋梁名 -----	2
フェーズⅠ対象橋梁名 -----	3
フェーズⅠ対象橋梁一般図 -----	4～27
鋼材詳細図 -----	28～31

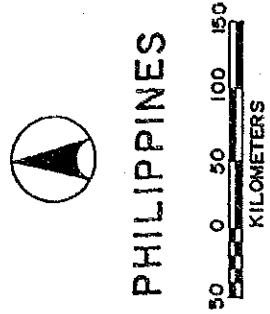

PHILIPPINES

要請橋梁位置図
SALINTANG CHANNEL

- フェーズI 橋梁
- ⊙ フェーズII 候補橋
- データなし、または早期架け替えの必要なし

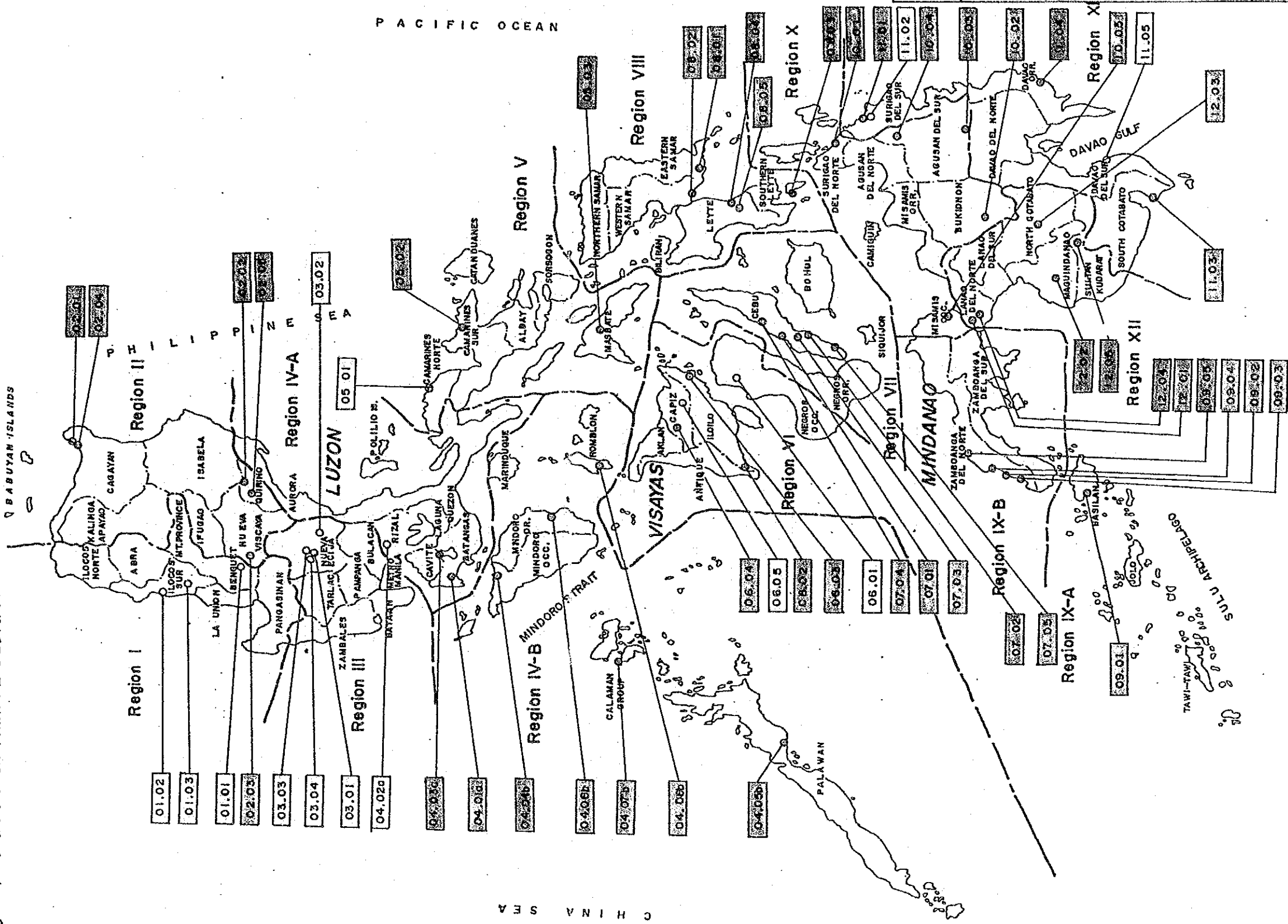

C H I N A S E A

BRIDGE NO.	NAME OF PROPOSED BRIDGES	SHEET NO.
		2/31

全要請橋梁名

番号	橋番号	橋名	位置	番号	橋番号	橋名	位置
1	01.01	ELLET BRIDGE	Km. 327+500, GUREL-BOKOD-KABAYAN-BUGUAS ROAD BOKOD-KABAYAN BOUNDARY, BENGUET	30	07.02	CAMPACAS BRIDGE	Km. 97+600, DALAGUETE-MANTALONGON ROAD DALAGUETE, CEBU
2	01.02	BIMMILOG BRIDGE	Km. 376+658, NARVACAN-SULVEC PORT ROAD TURCO, NARVACAN, ILOCOS SUR	31	07.03	CAMPANGA BRIDGE	Km. 63+500, CARCAR-BARILI-MANTAYUPAN ROAD BARILI, CEBU
3	01.03	MALAYA BRIDGE	Km. 376+570, TAGUDIN-CERVANTES ROAD CERVANTES, ILOCOS SUR	32	07.04	CAMACHILES BRIDGE	Km. 49+800, TOLEDO-TABUELAN-SAN REMEGIO ROAD TALAVERA, TOLEDO CITY
4	02.01	STA. CRUZ BRIDGE	Km. 640+747, DUGO-SAN VICENTE ROAD STA. ANA, CAGAYAN	33	07.05	LAGNASON BRIDGE	Km. 115+200, ANATALIO BACALSO AVENUE LAGUNDE, OSLOB, CEBU
5	02.02	DUMADATA BRIDGE	Km. 339+770, CORDON-DIFFUN-MADELLA-AURORA ROAD MANGANDINGAY, CABARROGUS, QUIRINO	34	08.01	PORAY BRIDGE	Km. 1043+798, JCT. BUENAVISTA-LAWA-AN ROAD PARINA, BALANGIGA, E. SAMAR
6	02.03	BAAN BRIDGE # 2	Km. 246+171, NUEVA VISCAYA-BENQUET ROAD BAAN, KAYAPA, NUEVA VIZCAYA	35	08.02	IBA BRIDGE	Km. 914+800, BASEY-MAGALLANES ROAD IBA, BASEY, SAMAR
7	02.04	DIORA BRIDGE	Km. 634+195, DUGO-SAN VICENTE ROAD STA. ANA, CAGAYAN	36	08.03	HABAY BRIDGE	Km. 1075+440, LILOAN-SAN FRANCISCO ROAD HABAY, SAN FRANCISCO, S. LEYTE
8	02.05	DIDUYON BRIDGE	Km. 374+060, CORDON-DIFFUN-MADELLA-AURORA ROAD MADELLA, QUIRINO	37	08.04	TALISAYAN RIVER CROSSING	Km. 66+440, LAPAZ-JAVIER-BITO ROAD TALISAYAN, JAVIER, LEYTE
9	03.01	SEGUM BRIDGE	Km. 153+798, JCT. TABLANG-GABALDON-QUEZON BOUNDARY ROAD PINTO, GABALDON, NUEVA ECIIJA	38	08.05	PINUCAWAN BRIDGE	Km. 68+280, LAPAZ-JAVIER-BITO ROAD JAVIER, LEYTE
10	03.02	CALABASA BRIDGE	Km. 157+269, JCT. TABLANG-GABALDON-QUEZON BOUNDARY ROAD CALABASA, GABALDON, NUEVA ECIIJA	39	09.01	BATUNGAL BRIDGE	Km. 26+440, ISABELA-MALUSO ROAD MALUSO, BASILAN
11	03.03	MALINAO BRIDGE	Km. 166+631, JCT. TABLANG-GABALDON-QUEZON BOUNDARY ROAD MALINAO, GABALDON, NUEVA ECIIJA	40	09.02	MANGOP BRIDGE	Km. 439+740, SINDANGAN-LILOY ROAD ZAMBOANGA DEL NORTE
12	03.04	ASAN BRIDGE	Km. 166+295, JCT. TABLANG-GABALDON-QUEZON BOUNDARY ROAD GABALDON, NUEVA ECIIJA	41	09.03	CANAWAN BRIDGE	Km. 449+740, SINDANGAN-LILOY ROAD ZAMBOANGA DEL NORTE
13	04.01a	BINAMBANG BRIDGE	Km. 107+540, BALAYAN-BALIBAGO-CALATAGAN ROAD CALOCCAN, BALAYAN, BATANGAS	42	09.04	PIANGON BRIDGE	Km. 337+380, DIPOLOG-SINDANGAN NATIONAL ROAD SINDANGAN, ZAMBOANGA DEL NORTE
14	04.02a	MANGO BRIDGE	Km. 26+700, SAN MATEO-RODRIGUEZ (MONTALBAN) ROAD RODRIGUEZ, RIZAL	43	09.05	PATUNAN BRIDGE	Km. 375+090, DIPOLOG-SINDANGAN ROAD MANUKAN, ZAMBOANGA DEL NORTE
15	04.03a	LEVISTE II BRIDGE	Km. 92+430, TALISAY-LAUREL-AGONCILLO ROAD LAUREL, BATANGAS	44	10.01	HAYANGABON I BRIDGE	Km. 1202+585, SURIGAO-DAVAO COASTAL ROAD HAYANGABON, CLAYER, SURIGAO DEL NORTE
16	04.04b	LUMANG BAYAN BRIDGE	Km. 34+954, MAMBURAO-NORTH PUERTO GALERA ROAD ORELAN, ABRA DE ILOG, MINDORO OCCIDENTAL	45	10.02	MARADUGAO BRIDGE	Km. 1608+942, MARADUSAO-CAMP KIBARITAN ROAD KALILANGAN, BUKIDNON
17	04.05b	OLANGOAN BRIDGE	Km. 74+524, PUERTO PRINCESA NORTH ROAD CONCEPCION, PUERTO PRINCESA CITY, PALAWAN	46	10.03	MAUNDO BRIDGE	Km. 1386+957, PULANG LUPA-PATROCINTO ROAD STA. JOSEFA, AGUSAN DEL SUR
18	04.06b	BONGABON BRIDGE	Km. 122+720, CALAPAN SOUTH-BULALACAO-SAN JOSE ROAD BONGABON, ORIENTAL MINDORO	47	10.04	STA. IRENE BRIDGE	Km. 1282+110, BAYUGAN-KALAITAN-TANDAG ROAD STA. IRENE, AGUSAN DEL SUR
19	04.07b	DIPULAO BRIDGE	Km. 2+706, CORON-BUSUANGA NATIONAL ROAD CORON, PALAWAN	48	10.05	MALUBOG BRIDGE	Km. 185+760, LABUYO-TANGUB-SILANGA ROAD BARANGAY 4, TANGUB CITY
20	04.08b	COGON BRIDGE	Km. 64+974, ODIONGAN (TULAY)-LOOC ROAD LOOC, ROMBLON	49	11.01	LAMBUNAO BRIDGE	Km. 1267+027, SURIGAO SUR-DAVAO COASTAL ROAD LANUZA, SURIGAO DEL SUR
21	05.01	DAGUIT BRIDGE	Km. 312+848, MANILA SOUTH ROAD DAGUIT, LABO, CAMARINES NORTE	50	11.02	BALIBADON BRIDGE # 3	Km. 1296+814, SURIGAO SUR-DAVAO COASTAL ROAD BALIBADON, CORTES, SURIGAO DEL SUR
22	05.02	PATITINAN BRIDGE	Km. 499+200, SAGHAY-TIWI-ALBAY BDRY. ROAD PATITINAN, SAGANAY, CAMARINES SUR	51	11.03	CALABANIT BRIDGE	Km. 1716+083, DAVAO DEL SUR-SOUTH COTABATO COASTAL ROAD GLAN, SOUTH COTABATO
23	05.03	NARANGASAN I BRIDGE	Km. 31+145, JCT. TAWAD-BALUD ROAD MLAGROS, MASBATE	52	11.04	MANAY BRIDGE	Km. 1643+783, DAVAO ORIENTAL-SURIGAO DEL SUR NATIONAL ROAD MANAY, DAVAO ORIENTAL
24	06.01	TALUS BRIDGE	Km. 41+150, MURCIA-DON SALVADOR-CALATRAVA ROAD MURCIA, NEGROS OCCIDENTAL	53	11.05	CULAMAN I BRIDGE	Km. 1650+758, DAVAO DEL SUR-SOUTH COTABATO COASTAL ROAD (HALALAG- DON MARCELINO-JOSE ABAD SANTOS SECTION), CULAMAN, MALITA, DAVAO DEL SUR
25	06.02	CATAAN BRIDGE	Km. 65+930, TIOLAS-SINOGBUHAN ROAD SAN JOAQUIN, ILOILO	54	12.01	PIKINIT BRIDGE	Km. 136+936, DOBLESTON-TUKURAN ROAD CAROMATAN, LANAO DEL NORTE
26	06.03	IYANG BRIDGE	Km. 109+962, CONCEPCION-SAN DIONISIO NATIONAL ROAD CONCEPCION, ILOILO	55	12.02	DURUGAO BRIDGE	Km. 216+498, AWANG-UPI-LEBEK ROAD DURUGAO, SOUTH UPI, MAGUINDANAO
27	06.04	GUINTAS BRIDGE	Km. 106+500, TAPAZ-JAMINDAN ROAD JAMINDAN, CAPIZ	56	12.03	UPIAN BRIDGE	Km. 239+002, COTABATO-BUKIONON ROAD KIMADZIL, CARMEN, NORTH COTABATO
28	06.05	TUMALALUD BRIDGE	Km. 104+400, JCT. NATIONAL ROAD-SAN RAFAEL ROAD TUMALALUD, DUMARAO, CAPIZ	57	12.04	DANGOLAN BRIDGE	Km. 133+983, DOBLESTON-TUKURAN ROAD CAROMATAN, LANAO DEL NORTE
29	07.01	BANBAN BRIDGE	Km. 61+100, PINAMUNGAHAN-ALOGUINSAN-MANTALONGON ROAD PINAMUNGAHAN, CEBU	58	12.05	SAPAKAN BRIDGE	Km. 211+530, DJULAWAN-MARBEL ROAD SAPAKAN, MAGUINDANAO

フェーズ I 対象橋梁名

番号	橋番号	橋名	位置	番号	橋番号	橋名	位置
1	02.03	BAAN BRIDGE	Km.246+171, Nueva Vizcaya-Bengual Road Baan, Kayapa, Nueva Vizcaya	13	08.05	PINUCAWAN BRIDGE	Km.68+280, La Paz-Javler-Bito Road Javler, Leyte
2	02.04	DIORA BRIDGE	Km.634+195, Dugo-San Vicente Road Sta. Ana, Cagayan	14	09.01	BATUNGAL BRIDGE	Km.26+440, Isabela-Maluso Road Maluso, Basilan
3	04.07b	DIPULAO BRIDGE	Km.2+706, Coron-Busuanga National Road Coron, Palawan	15	09.02	MANGOP BRIDGE	Km.439+740, Sindangan-Liloy Road Zamboanga del Norte
4	04.08b	COGON BRIDGE	Km.64+974, Odlongan(Tulay)-Looc Road Looc, Romblon	16	09.03	CANAWAN BRIDGE	Km.449+740, Sindangan-Liloy Road Zamboanga del Norte
5	05.02	PATITINAN BRIDGE	Km.499+200, Sagnay-Tiwi-Alboy B Patitinan, Sagayan, Camarines Sur	17	09.04	PIANGON BRIDGE	Km.337+380, Dipolog-Sindangan National Road Sindangan, Zamboanga del Norte
6	06.02	CATAAN BRIDGE	Km.65+930, Titas-Sinogbuan Road San Joaquin, Iloilo	18	10.02	MARADUGAO BRIDGE	Km.1608+942, Maradugao - Camp Kibaritan Road Kalilangan.
7	06.04	GUINTAS BRIDGE	Km.106+500, Tapaz-Jamindan Road Jamindan, Capiz	19	10.03	MAUNDO BRIDGE	Km.1386+957, Pulang Lupa - Patrocinto Road Sta. Josefa, Agusan del Sur
8	07.03	CAMPANGA BRIDGE	Km.63+500, Carcar-Barili-Mantayupan Road Barili, Cebu	20	10.04	STA. IRENE BRIDGE	Km.1282+110, Bayugan-Kalaitan-Tandag Road Sta. Irene, Agusan del Sur
9	07.04	CAMACHILES BRIDGE	Km.49+800, Toledo-Tabuelan-San Remigio Road Talavera, Toledo City	21	10.05	MALUBOG BRIDGE	Km.185+760, Labuyo-Tangub-Sitanga-Road Barangay 4, Tangub City
10	07.05	LAGNASON BRIDGE	Km.115+200, Anatolio Bacalso Avenue Lagunda, Ostob, Cebu	22	11.01	LAMBUNAO BRIDGE	Km.1267+027, Surigao Sur-Davao Coastal Road Lanuz, Surigao del Sur
11	08.01	PORAY BRIDGE	Km.1043+798, Jct. Buenavista-Lawa-an Road Parina, Balangiga, Eastern Samar	23	11.03	CALABANIT BRIDGE	Km.1716+083, Davao del Sur - South Cotabato Coastal Road, Glan, South Cotabato
12	08.02	IBA BRIDGE	Km.914+800, Basey-Magallanes Road Iba, Basey, Samar	24	12.03	UPIAN BRIDGE	Km.239+002, Cotabato-Bukidnon Road Klmdzil, Carmen, North Cotabato

BASIC DESIGN STUDY ON THE PROJECT FOR CONSTRUCTING BRIDGES ALONG RURAL ROADS (PHASE I)		
BRIDGE NO.	BAAN BRIDGE # 2	SHEET NO
02-03	Km. 246 + 171	4/31

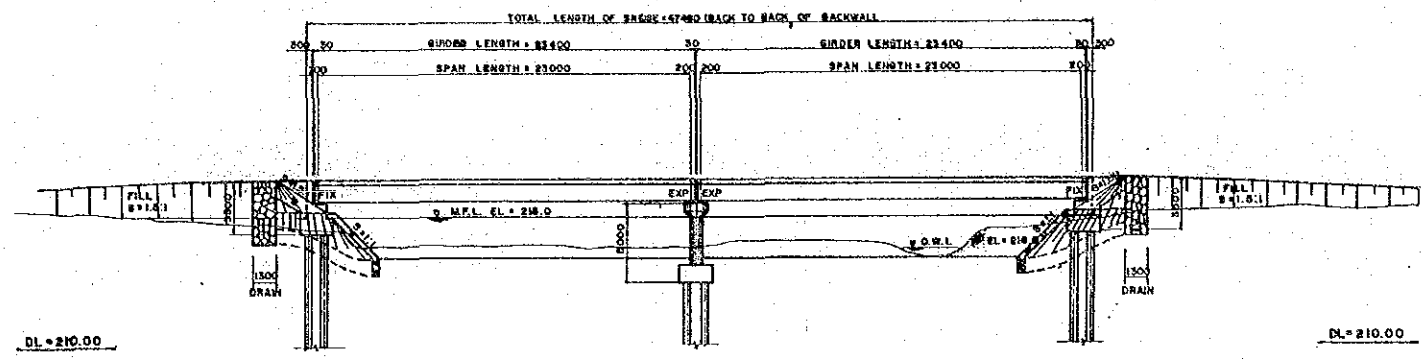

GENERAL ELEVATION
SCALE: 1:200

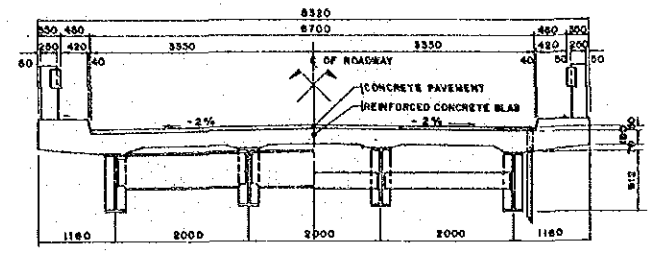

SUPERSTRUCTURE CROSS SECTION
SCALE: 1:50

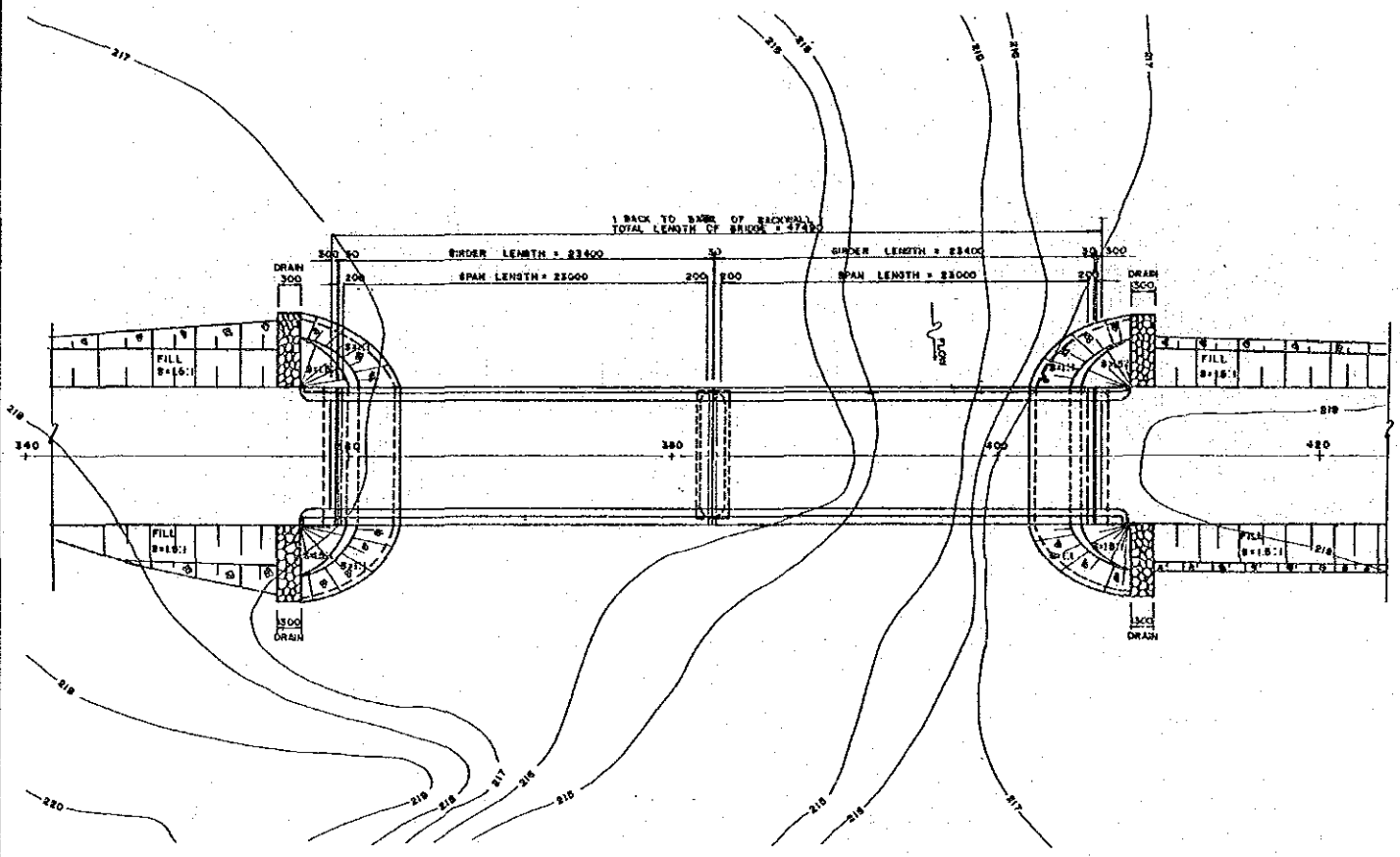

GENERAL PLAN
SCALE: 1:200

DRAWINGS
All dimensions are expressed in millimeter unless otherwise shown in the plans.
All elevations are in meters.

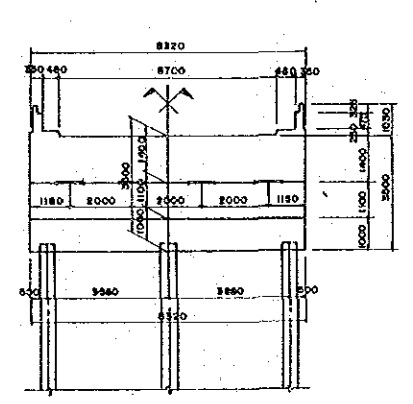

ABUTMENT

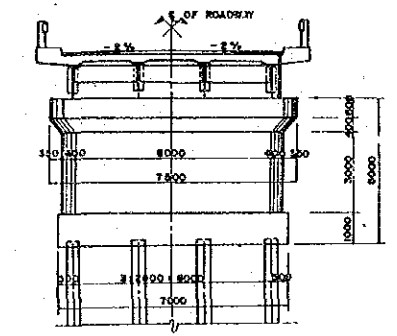

PIER

SUBSTRUCTURE CROSS SECTION
SCALE: 1:100

GENERAL NOTES

- Location of bridge should be determined by the Department of Public Works and Highways (DPWH).
- Structural dimensions of superstructures should not be amended.
- Types and dimensions of substructures shall be justified according to the detailed design of substructures prepared by DPWH.
- Vertical clearance between the M.F.L. and the bottom of the girders of the superstructure shall be not less than 1.0 meter (Carrying no big debris).
- DESIGN SPECIFICATION
AASHTO Standard Specifications for Highway Bridges (13th Edition 1983)
- DESIGN LOAD

Dead Load: Concrete	23.54 KN/m ³
Fill Material	17.46 KN/m ³
Concrete Pavement	23.54 KN/m ³
Live Load: Roadway Live Load	HS 20-44 (HS-18)
Sidewalk Live Load	2.875 KN/m ²

Temperature Change:
Rise +10°, Fall -10°
Earthquake Load:
C = 0.12 with Reference to Relevant AASHTO Provisions and Applicable Code.
Other Loads: In accordance with 1983 AASHTO Specification.

- MATERIALS

Steel for Superstructure:
Steel shall be Specified by JIS (Japanese Industrial Standard).

Concrete:
Concrete for Superstructure $f'_c = 29.4$ MPa
Concrete for Substructure $f'_c = 20.7$ MPa

Others:
Other Materials shall conform to ASTM

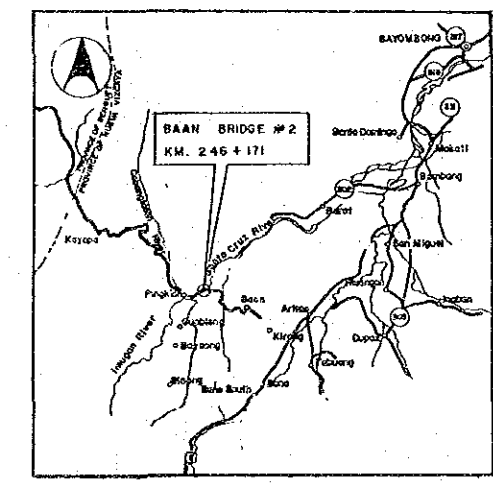

VICINITY MAP

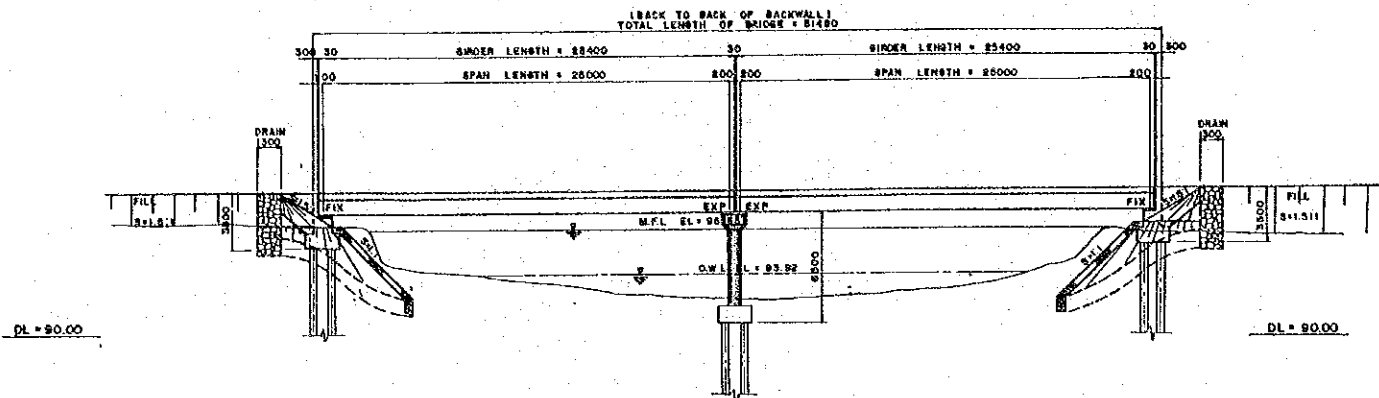

GENERAL ELEVATION
SCALE: 1:200

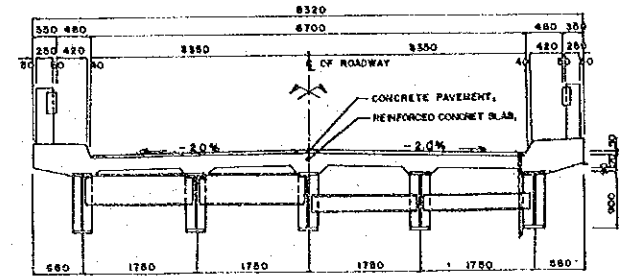

SUPERSTRUCTURE CROSS SECTION
SCALE: 1:50

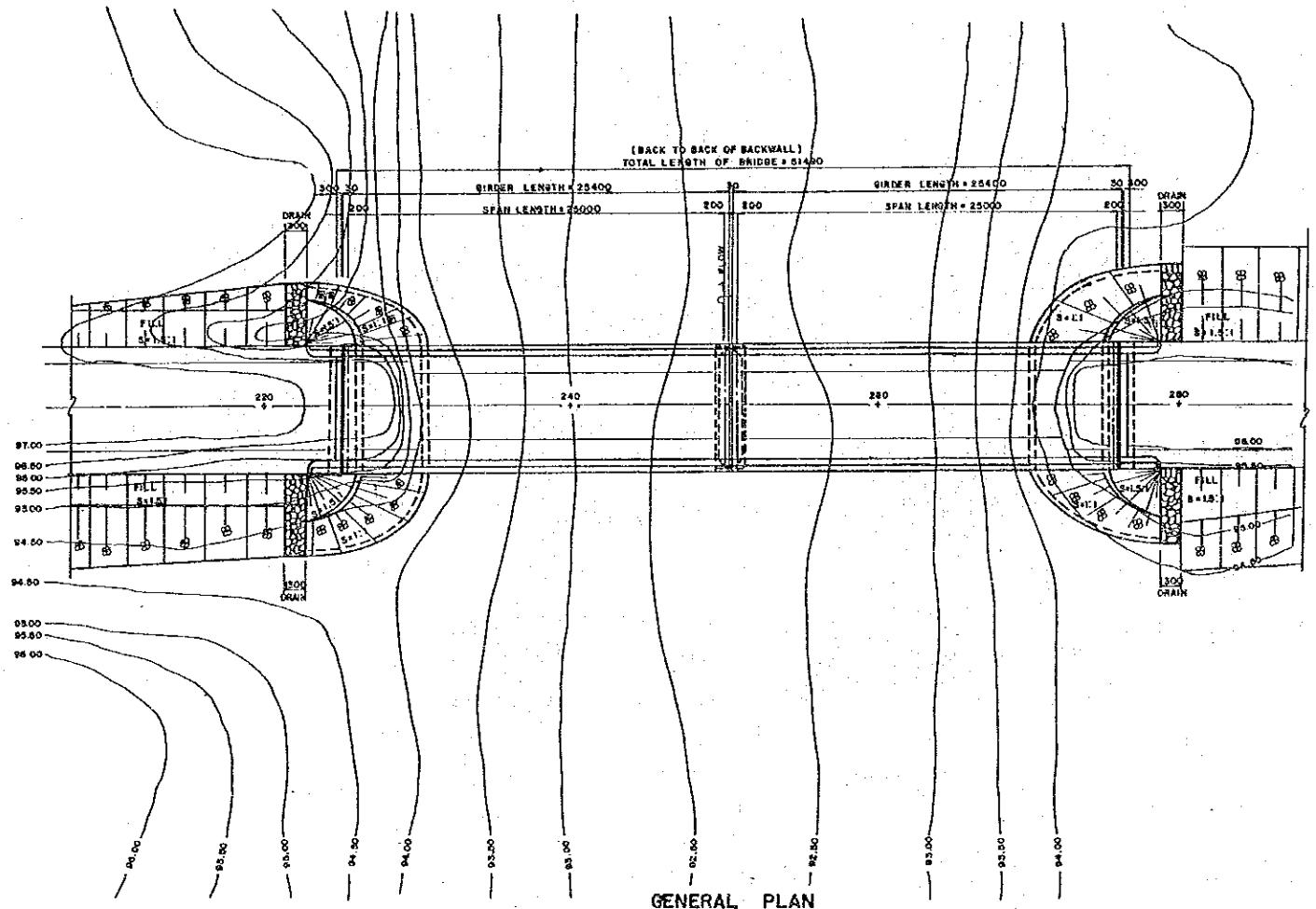

GENERAL PLAN
SCALE: 1:200

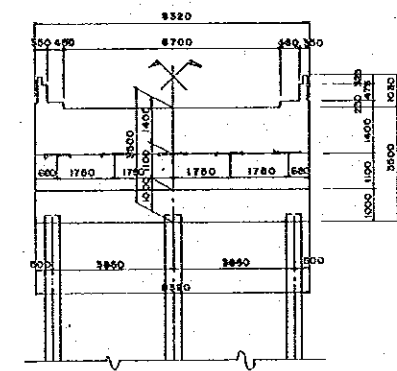

ABUTMENT

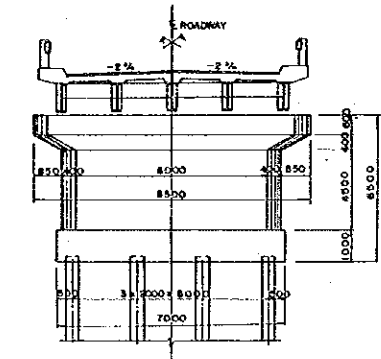

PIER

SUBSTRUCTURE CROSS SECTION
SCALE: 1:100

GENERAL NOTES

1. Location of bridge should be determined by the Department of Public Works and Highways (DPWH).
2. Structural dimensions of superstructure should not be amended.
3. Types and dimensions of substructures shall be justified according to the detailed design of substructures prepared by DPWH.
4. Vertical clearance between the M.F.L. and the bottom of the girders of the superstructure shall be not less than 1.0 meter (Carrying no big debris).
5. DESIGN SPECIFICATION
AASHTO Standard Specifications for Highway Bridges (13th Edition 1983)
6. DESIGN LOAD

Dead Load:	Concrete	23.54 KN/m ³
	FJI Materials	17.66 KN/m ³
	Concrete Pavement	23.54 KN/m ³
Live Load:	Roadway Live Load	HS 20-44 (MS-10)
	Sidewalk Live Load	2.873 KN/m ²
Temperature	Change:	Rise +10°, Fall -10°
Earthquake	Load:	C = 0.12 with Reference to Relevant AASHTO Provisions and Applicable Code.
Other Loads:		In accordance with 1983 AASHTO Specification.
7. MATERIALS
Steel for Superstructures:
Steel shall be Specified by JIS (Japanese Industrial Standard).
Concrete: Concrete for Superstructure $f_c' = 29.4$ MPa
Concrete for Substructures $f_c' = 20.7$ MPa
Others: Other Materials shall conform to ASTM

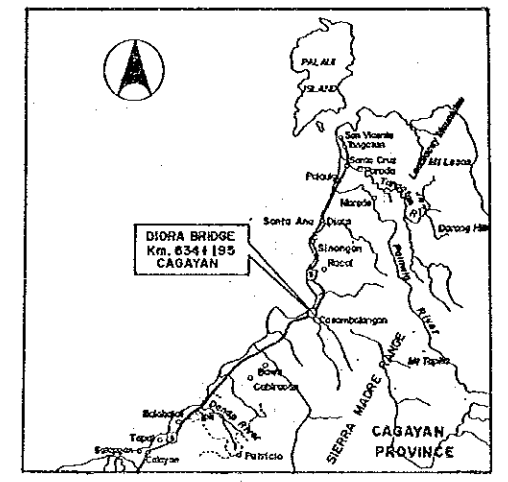

VICINITY MAP

DRAWINGS
All dimensions are express in millimeter unless otherwise shown in the plans.
All elevations are in meters.

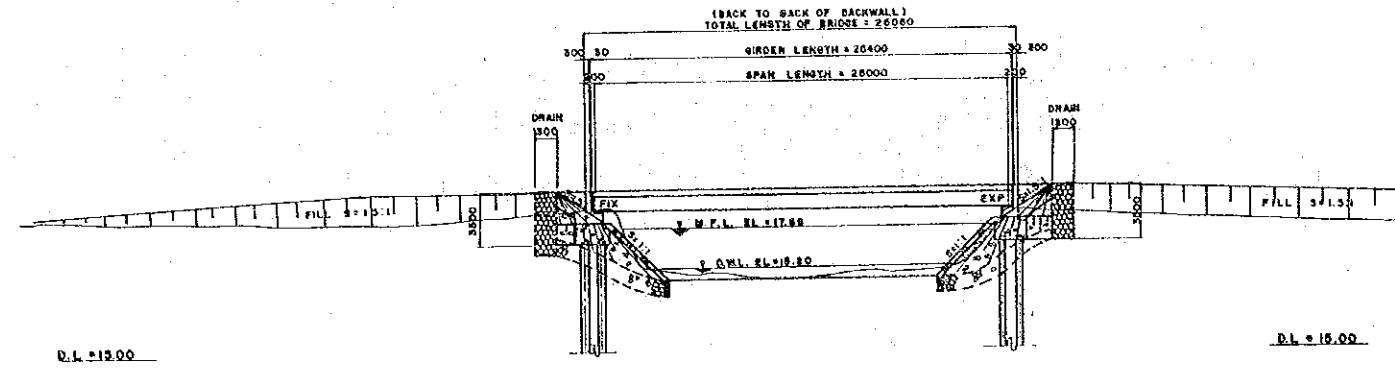

GENERAL ELEVATION
SCALE: 1:200

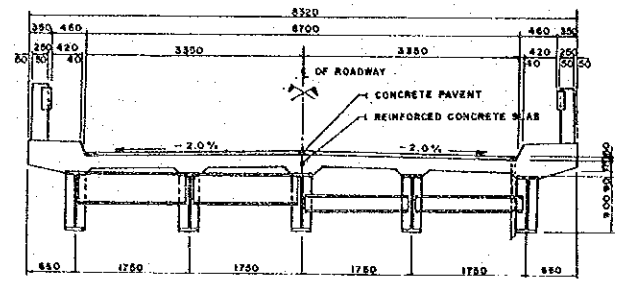

SUPERSTRUCTURE CROSS SECTION
SCALE: 1:50

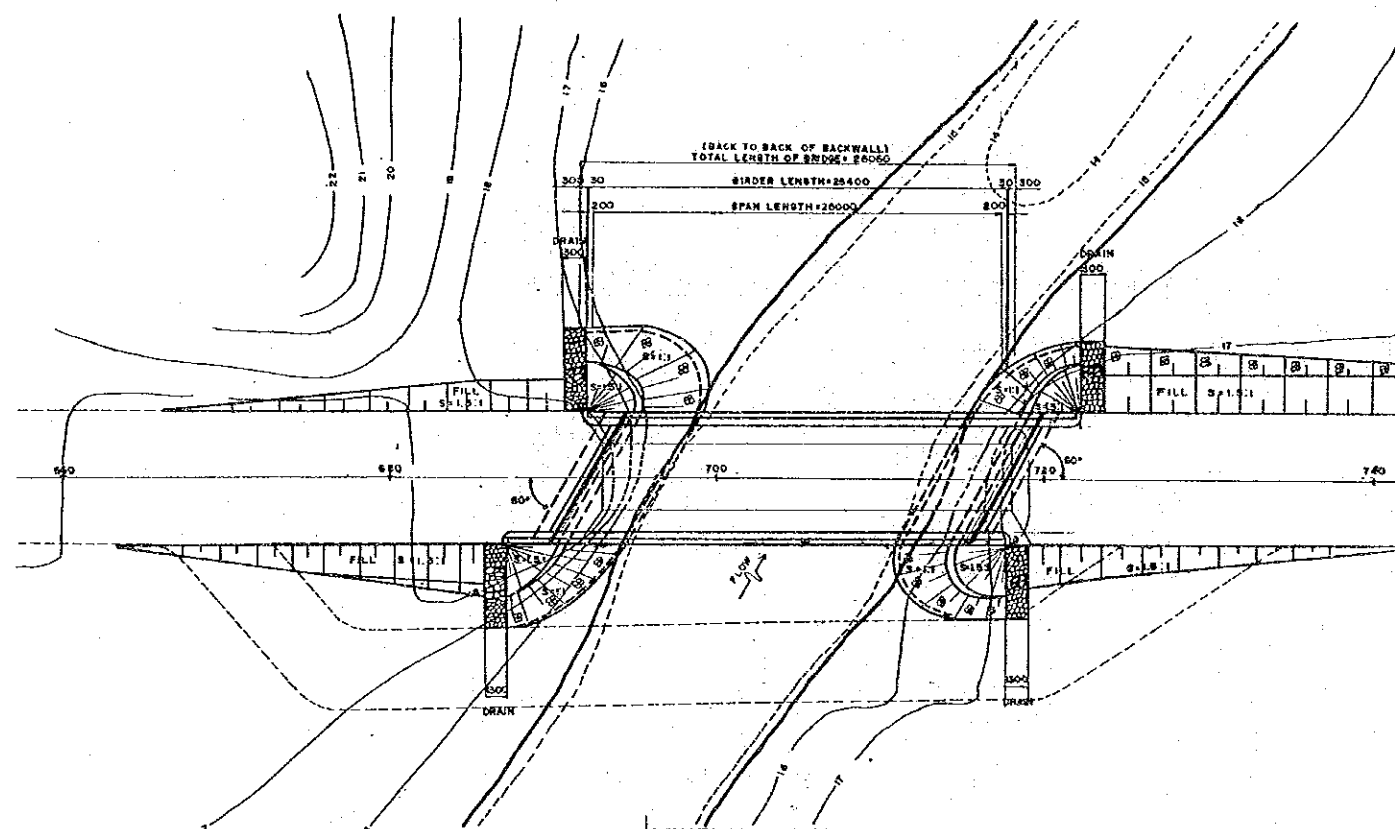

GENERAL PLAN
SCALE: 1:200

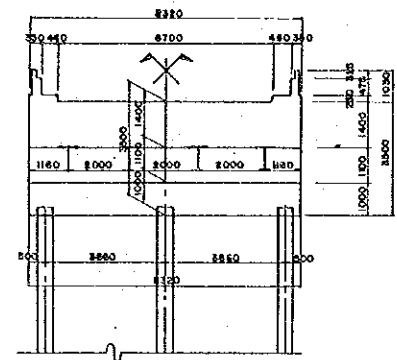

SUBSTRUCTURE CROSS SECTION
SCALE: 1:100

GENERAL NOTES

1. Location of bridge should be determined by the Department of Public Works and Highways (DPWH).
2. Structural dimensions of superstructures should not be amended.
3. Types and dimensions of substructures shall be justified according to the detailed design of substructures prepared by DPWH.
4. Vertical clearance between the M.F.L. and the bottom of the girders of the superstructure shall be not less than 1.0 meter (Carrying no big debris).
5. DESIGN SPECIFICATION
AASHTO Standard Specifications for Highway Bridges (13th Edition 1983)
6. DESIGN LOAD

Dead Load:	Concrete	23.54 KN/m ³
	Fill Materials	17.60 KN/m ³
	Concrete Pavement	23.54 KN/m ³
Live Load:	Roadway Live Load	HS 20-44 (MS-18)
	Sidewalk Live Load	2.873 KN/m ²

Temperature Change:
Rise +10°, Fall -10°

Earthquake Load:
C=0.12 with Reference to Relevant AASHTO Provisions and Applicable Code.

Other Loads: In accordance with 1993 AASHTO Specification.
7. MATERIALS

Steel for Superstructure:
Steel shall be Specified by JIS (Japanese Industrial Standard).

Concrete:
Concrete for Superstructure: $f_c = 29.4 \text{ MPa}$
Concrete for Substructure: $f_c = 20.7 \text{ MPa}$

Others:
Other Materials shall conform to ASTM

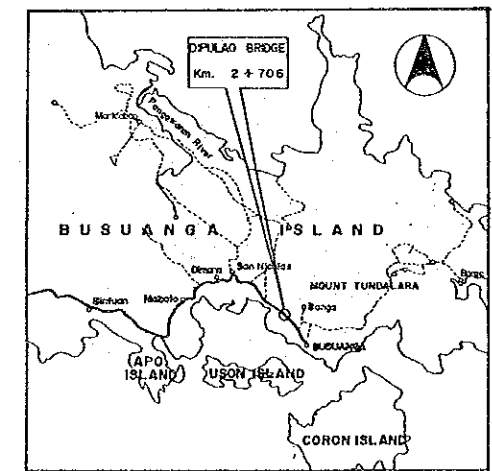

VICINITY MAP

DRAWINGS
All Dimensions are express in millimeter unless otherwise show in the plans
All Elevations are in meters.

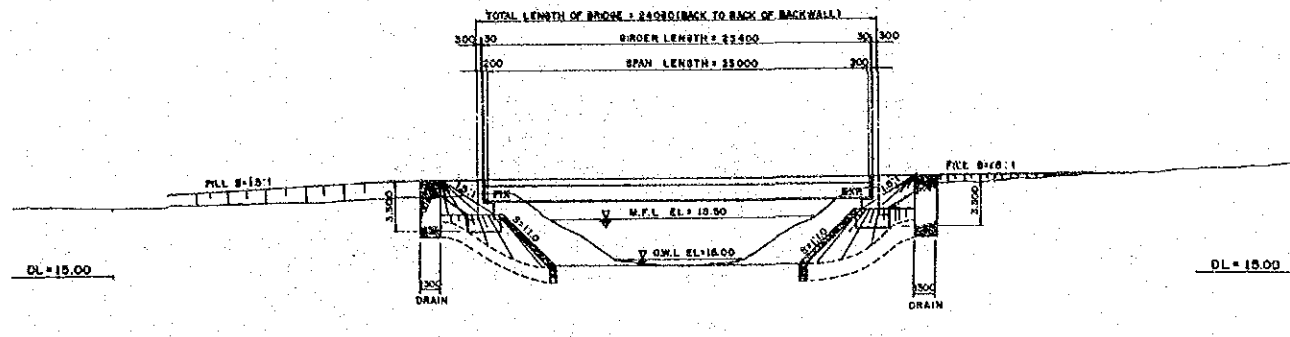

GENERAL ELEVATION
SCALE: 1:200

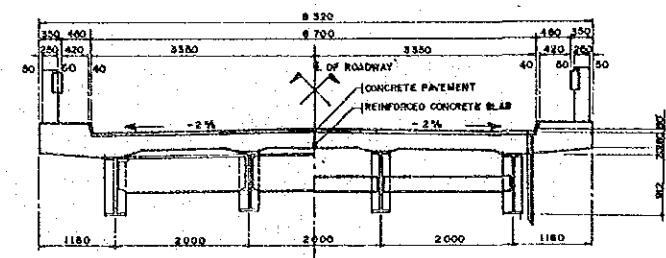

SUPERSTRUCTURE CROSS SECTION
SCALE: 1:50

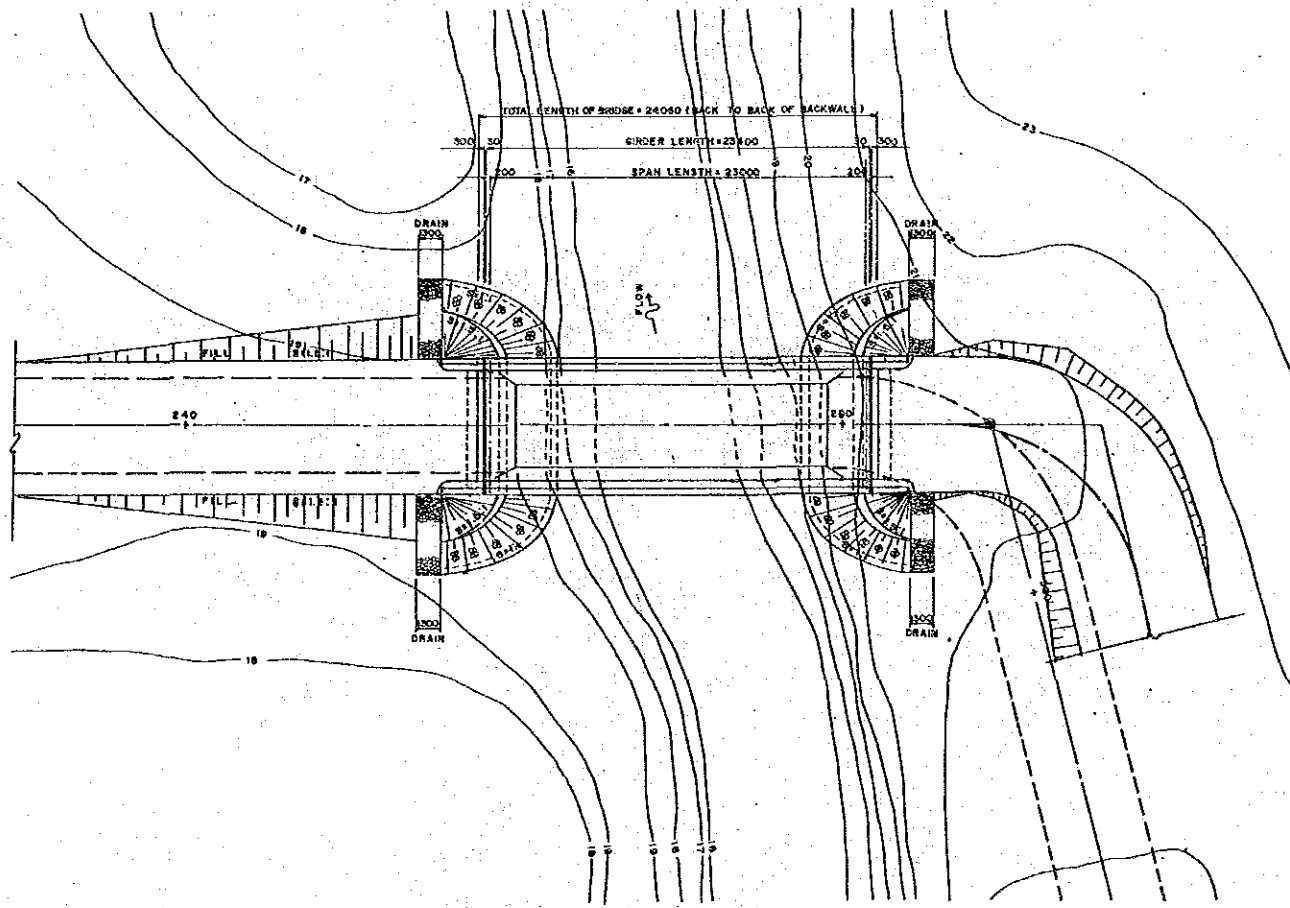

GENERAL PLAN
SCALE: 1:200

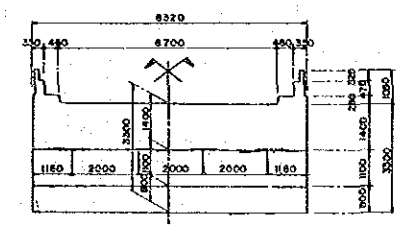

SUBSTRUCTURE CROSS SECTION
SCALE: 1:100

GENERAL NOTES

1. Location of bridge should be determined by the Department of Public Works and Highways (DPWH).
2. Structural dimensions of superstructures should not be amended.
3. Types and dimensions of substructures shall be justified according to the detailed design of substructures prepared by DPWH.
4. Vertical clearance between the M.F.L. and the bottom of the girders of the superstructure shall be not less than 1.0 meter (Carrying no big debris).
5. DESIGN SPECIFICATION
AASHTO Standard Specifications for Highway Bridges (13th Edition 1993)
6. DESIGN LOAD

Dead Load:	Concrete	23.54 KN/m ³
	Fill Materials	17.56 KN/m ³
	Concrete Pavement	23.54 KN/m ³
Live Load:	Roadway Live Load	HS 20-44 (MS 18)
	Sidewalk Live Load	2.875 KN/m ²
- Temperature Change:
Rise +10°, Fall -10°
- Earthquake Load:
C = 0.12 with Reference to Relevant AASHTO Provisions and Applicable Code
- Other Loads: in accordance with 1993 AASHTO Specification.
7. MATERIALS

Steel for Superstructure:	Steel shall be Specified by JIS (Japanese Industrial Standard).
Concrete:	Concrete for Superstructure $f_c = 29.4 \text{ MPa}$
	Concrete for Substructure $f_c = 20.7 \text{ MPa}$
Others:	Other Materials shall conform to ASTM.

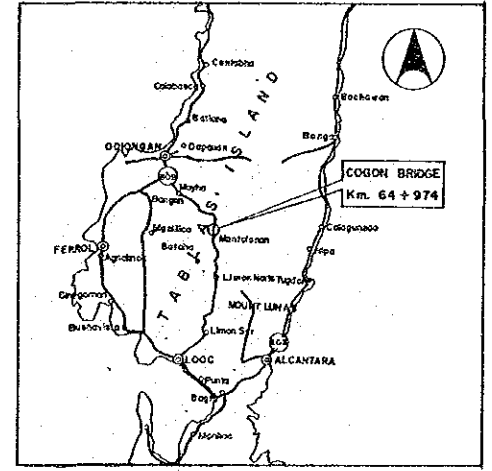

VICINITY MAP

DRAWINGS
All Dimensions are express in millimeter unless otherwise shown in the plans.
All Elevations are in meters.

BASIC DESIGN STUDY ON THE PROJECT FOR CONSTRUCTING BRIDGES ALONG RURAL ROADS (PHASE I)		
BRIDGE NO. 05-02	PATITINAN BRIDGE Km. 499+200	SHEET NO. 8/31

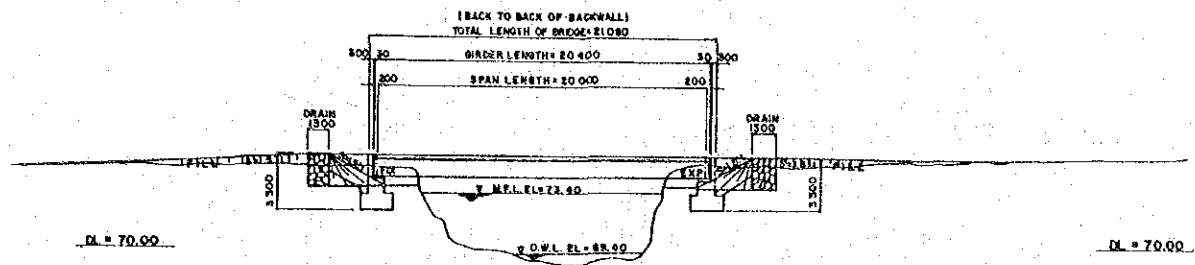

GENERAL ELEVATION
SCALE: 1:200

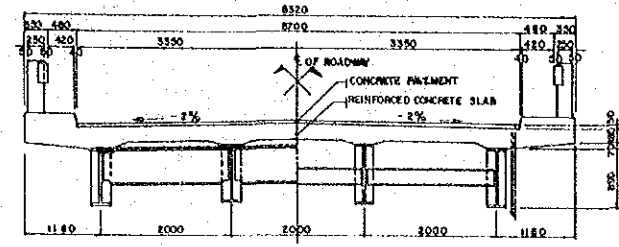

SUPERSTRUCTURE CROSS SECTION
SCALE: 1:50

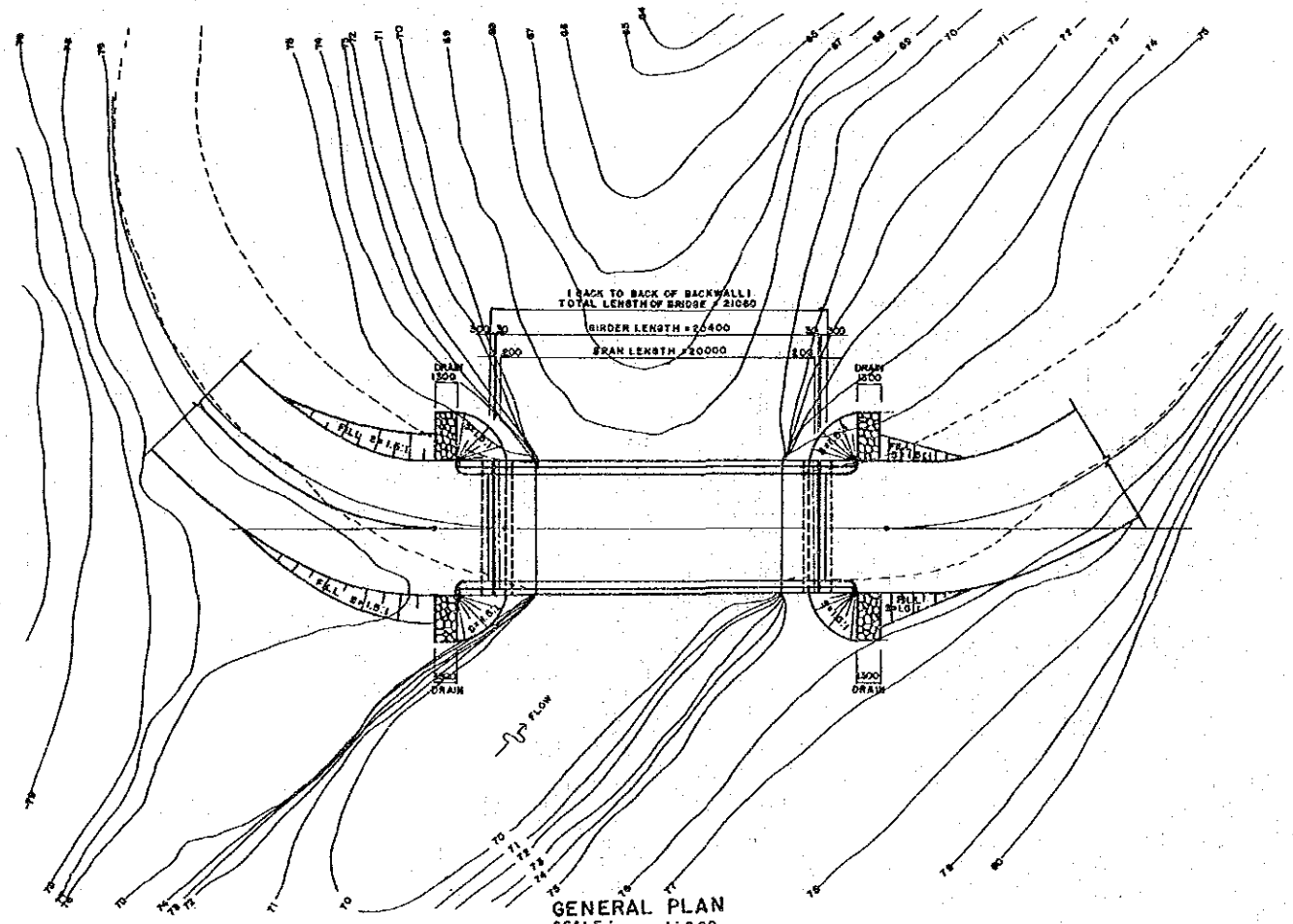

GENERAL PLAN
SCALE: 1:200

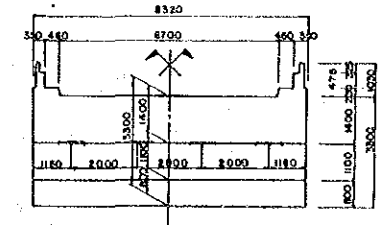

SUBSTRUCTURE CROSS SECTION
SCALE: 1:100

GENERAL NOTES

- Location of bridge should be determined by the Department of Public Works and Highways (DPWH).
- Structural dimensions of superstructures should not be amended.
- Types and dimensions of substructures shall be justified according to the detailed design of substructures prepared by DPWH.
- Vertical clearance between the M.F.L. and the bottom of the girders of the superstructure shall be not less than 10 meter (Carrying no big debris).
- DESIGN SPECIFICATION
AASHTO Standard Specifications for Highway Bridges (13th Edition 1983)
- DESIGN LOAD

Dead Load:	Concrete	23.54 KN/m ³
	Fill Material	17.06 KN/m ³
	Concrete Pavement	23.54 KN/m ³
Live Load:	Roadway Live Load	HS 20-44 (MS-18)
	Slowway Live Load	2.875 KN/m ²
Temperature Change:		Rise +10°, Fall -10°
Earthquake Load:		C=0.12 with Reference to Relevant AASHTO Provisions and Applicable Code
Other Loads:		In accordance with 1983 AASHTO Specification.
- MATERIALS

Steel for Superstructure:	Steel shall be Specified by JIS (Japanese Industrial Standard).
Concrete:	Concrete for Superstructure f _c '=29.4 MPa Concrete for Substructure f _c '=20.7 MPa
Others:	Other Materials shall conformed to ASTM

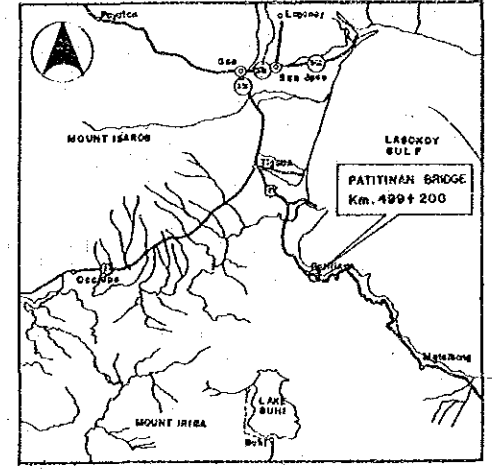

VICINITY MAP

DRAWINGS
 All Dimensions are express in millimeter unless otherwise shown in the plans.
 All Elevations are in meters.

BASIC DESIGN STUDY ON THE PROJECT
FOR CONSTRUCTING BRIDGES ALONG RURAL ROADS (PHASE I)

BRIDGE NO.	CATAAN BRIDGE	SHEET NO.
06-02	Km. 65 + 930	9/31

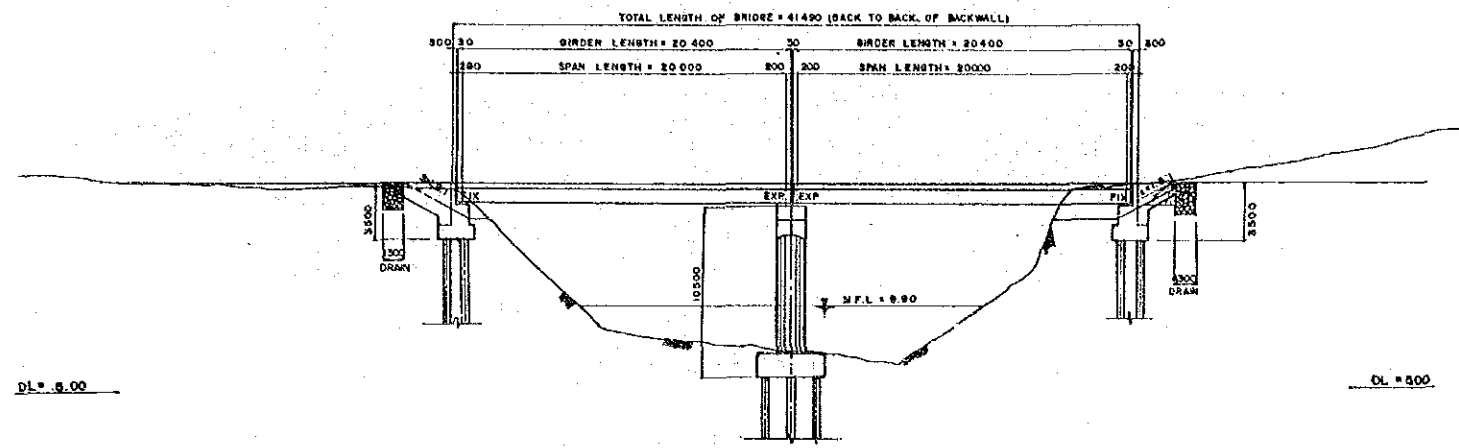

GENERAL ELEVATION
SCALE: 1:200

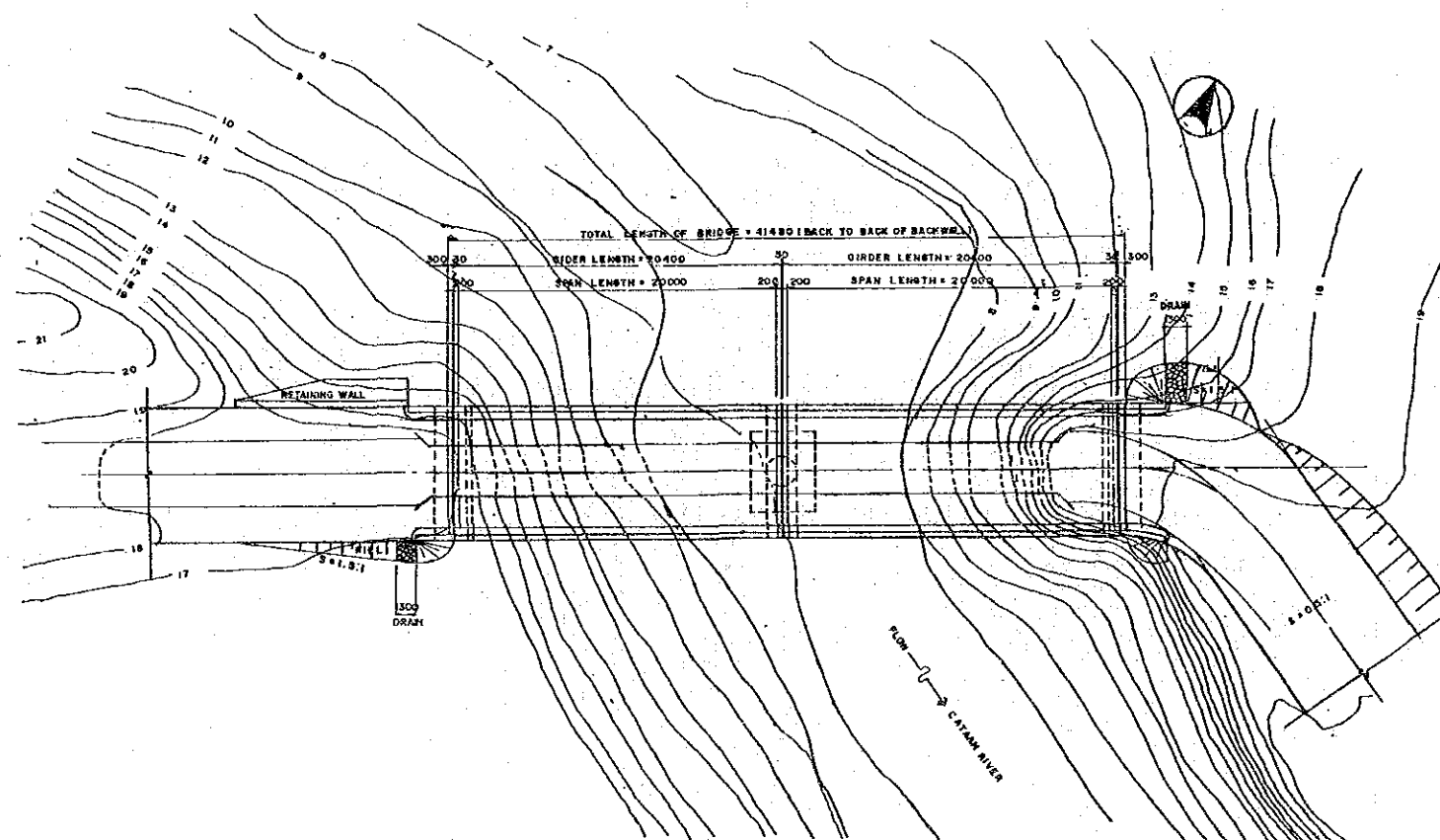

GENERAL PLAN
SCALE: 1:200

DRAWINGS
All Dimensions are express in millimeter unless otherwise shown in the plans.
All Elevations are in meters.

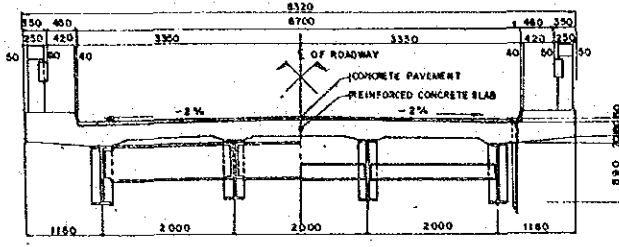

SUPERSTRUCTURE CROSS SECTION
SCALE: 1:50

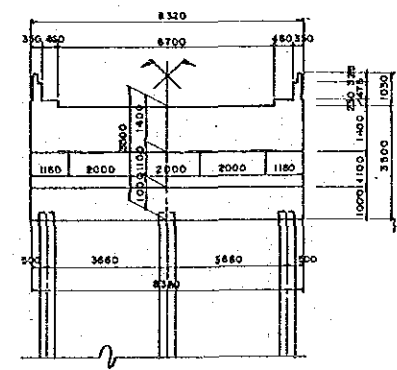

ABUTMENT

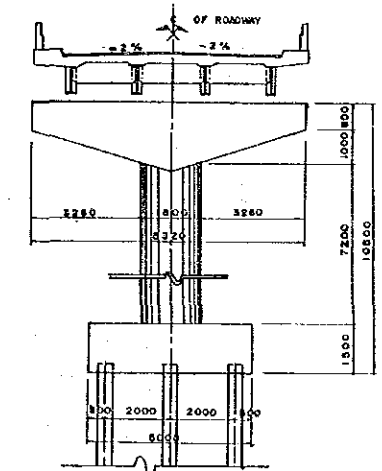

PIER

SUBSTRUCTURE CROSS SECTION
SCALE: 1:100

GENERAL NOTES

- Location of bridge should be determined by the Department of Public Works and Highways (DPWH).
- Structural dimensions of superstructures should not be amended.
- Type and dimensions of substructures shall be justified according to the detailed design of substructures prepared by DPWH.
- Vertical clearance between the M.F.L. and the bottom of the girders of the superstructure shall be not less than 1.0 meter (Carrying no big debris).
- DESIGN SPECIFICATION
AASHTO Standard Specifications for Highway Bridges (13th Edition 1983)
- DESIGN LOAD

Dead Load:	Concrete	23.54 KN/m ³
	Fill Materials	17.66 KN/m ³
	Concrete Pavement	23.54 KN/m ³
Live Load:	Roadway Live Load	HS20-44 (MS-18)
	Sidewalk Live Load	2.873 KN/m ²
Temperature Change:	Rise +10°, Fall -10°	
Earthquake Load:	C = D.12 with Reference to Relevant AASHTO Provisions and Applicable Code.	
Other Loads:	In accordance with 1983 AASHTO Specification.	
- MATERIALS

Steel for Superstructure:	Steel shall be Specified by JIS (Japanese Industrial Standard).
Concrete:	Concrete for Superstructure f _c ' = 29.4 MPa
	Concrete for Substructure f _c ' = 20.7 MPa
Others:	Other Materials shall conform to ASTM

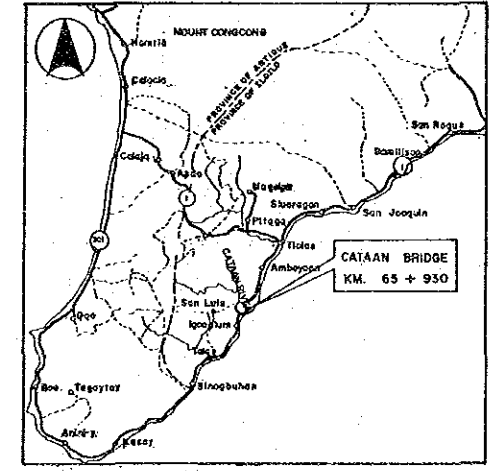

VICINITY MAP

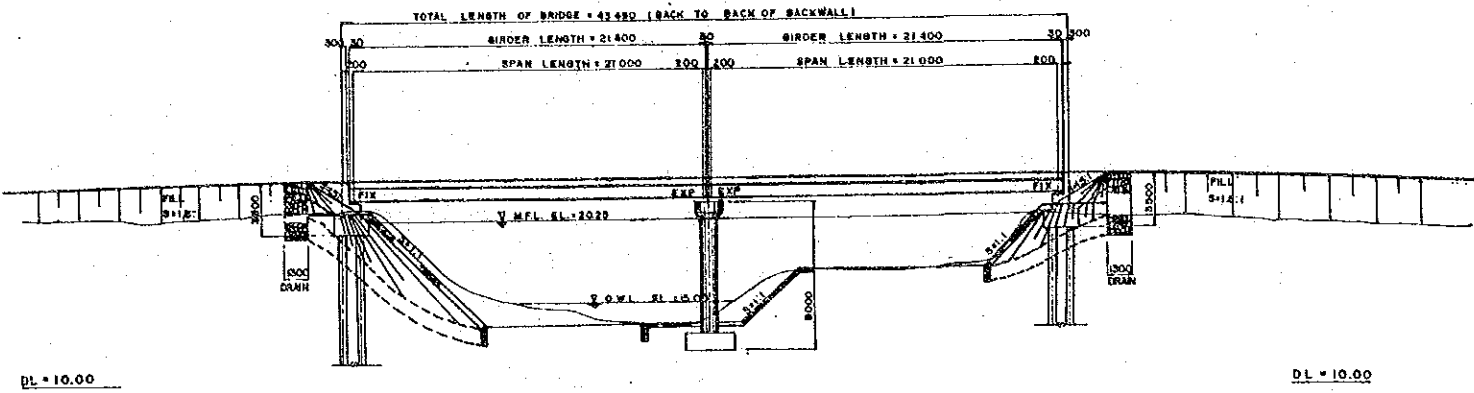

GENERAL ELEVATION
SCALE 1:200

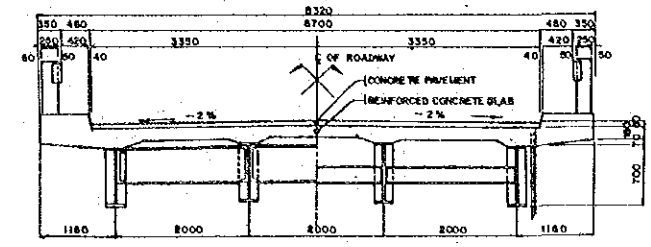

SUPERSTRUCTURE CROSS SECTION
SCALE 1:50

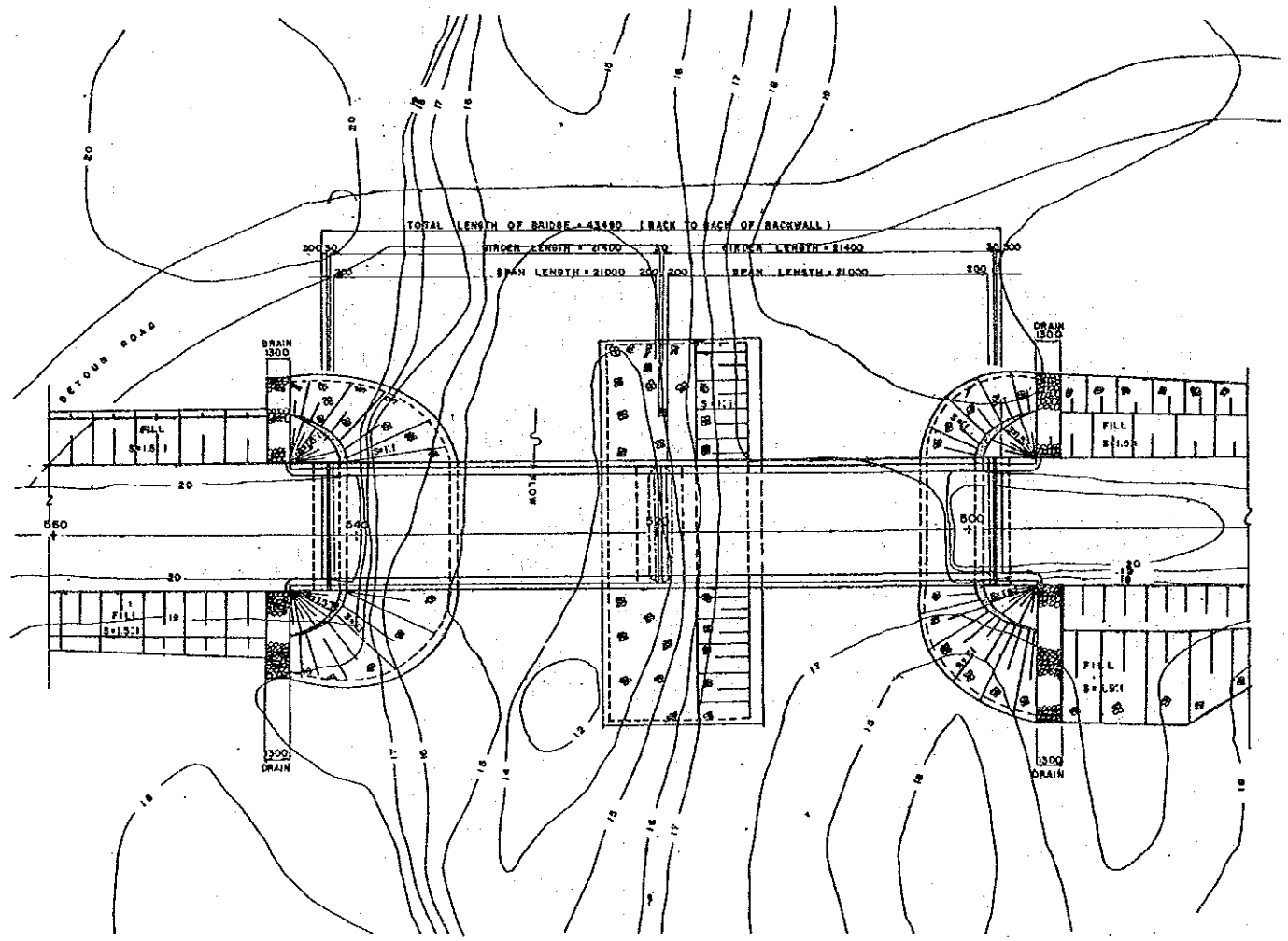

GENERAL PLAN
SCALE 1:200

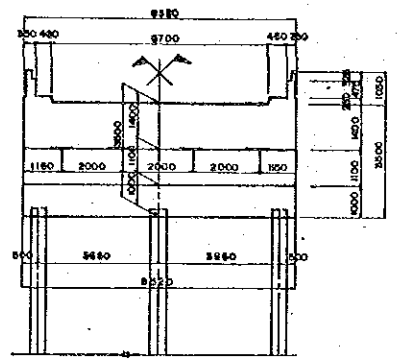

ABUTMENT

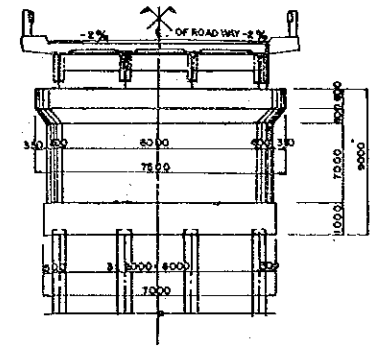

PIER

SUBSTRUCTURE CROSS SECTION
SCALE 1:100

GENERAL NOTES

1. Location of bridge should be determined by the Department of Public Works and Highways (DPWH).
2. Structural dimensions of superstructures should not be amended.
3. Types and dimensions of substructures shall be justified according to the detailed design of substructures prepared by DPWH.
4. Vertical clearance between the M.F.L. and the bottom of the girders of the superstructure shall be not less than 1.0 meter (Carrying no big debris).
5. DESIGN SPECIFICATION
AASHTO Standard Specifications for Highway Bridges (13th Edition 1983)
6. DESIGN LOAD

Dead Load:	Concrete	23.64 KN/m ³
	Fill Materials	17.66 KN/m ³
	Concrete Pavement	23.54 KN/m ³
Live Load:	Roadway Live Load	HS 20-44 (MS-18)
	Sidewalk Live Load	2.875 KN/m ²
- Temperature Change:
Rise +10°, Fall -10°
- Earthquake Load:
C = 0.12 with Reference to Relevant AASHTO Provisions and Applicable Code.
- Other Loads: In accordance with 1983 AASHTO Specification.
7. MATERIALS
Steel for Superstructure:
Steel shall be Specified by JIS (Japanese Industrial Standard).
- Concrete:
Concrete for Superstructure: f_c = 29.4 MPa
Concrete for Substructure: f_c = 20.7 MPa
- Others: Other Materials shall conformed to ASTM

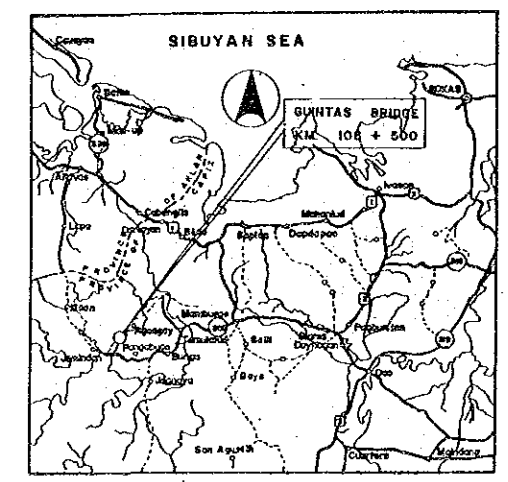

VICINITY MAP

DRAWINGS.
All Dimensions are express in millimeter unless otherwise shown in the plans.
All Elevations are in meters.

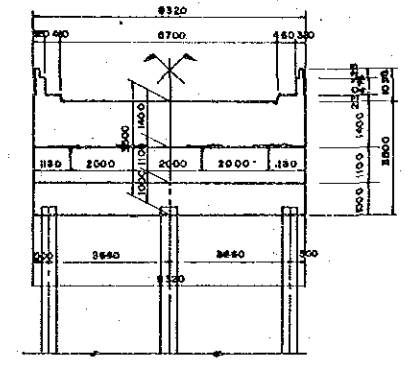
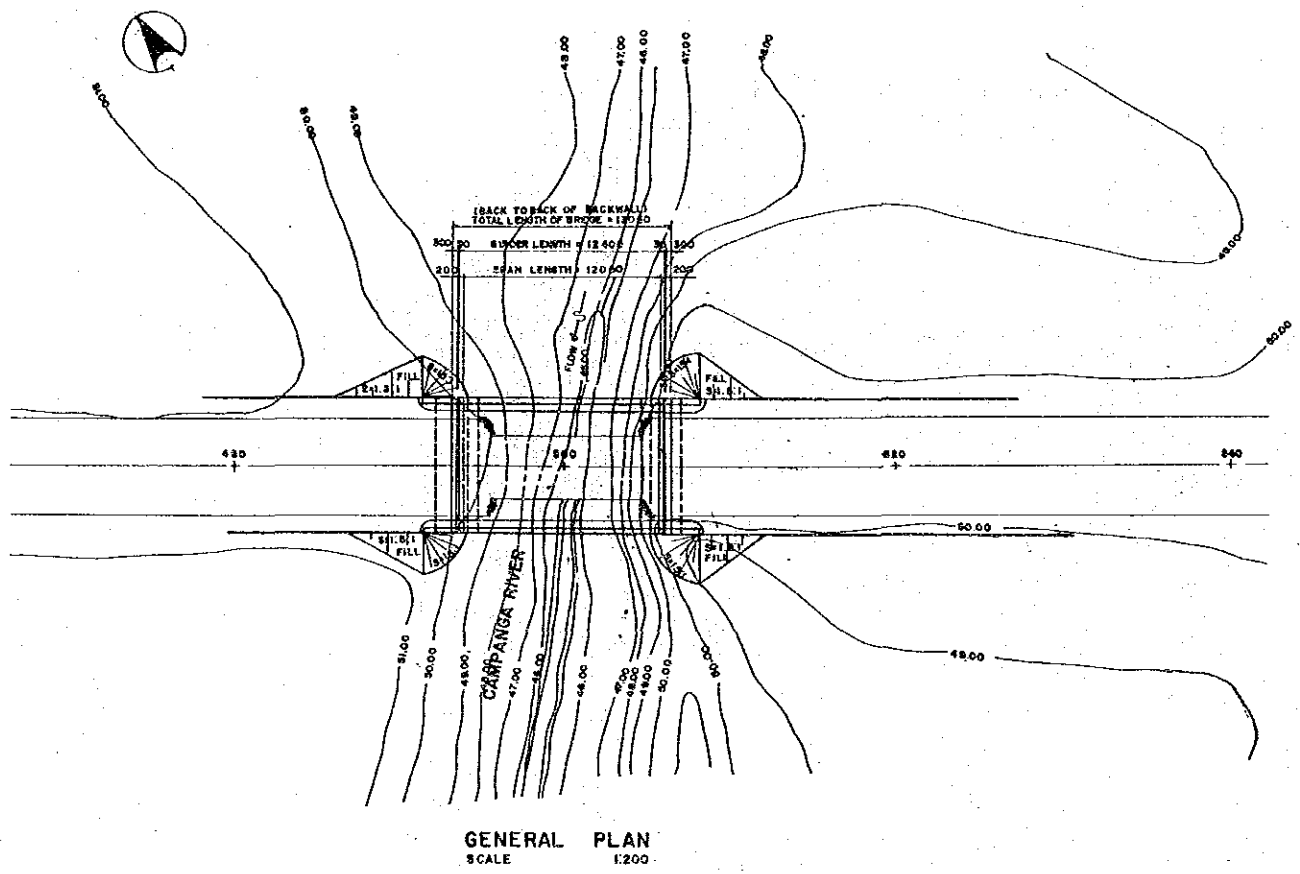
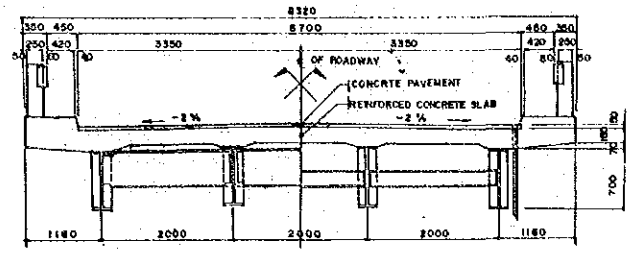
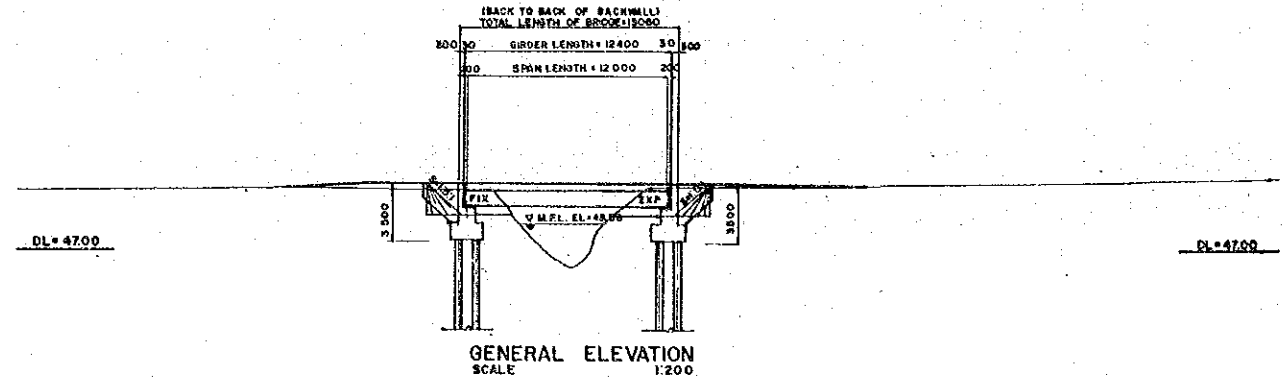

GENERAL NOTES

1. Location of bridge should be determined by the Department of Public Works and Highways (DPWH).
2. Structural dimensions of superstructures should not be amended.
3. Types and dimensions of substructures shall be justified according to the detailed design of substructures prepared by DPWH.
4. Vertical clearance between the M.F.L. and the bottom of the girders of the superstructure shall be not less than 1.0 meter (Carrying no big debris).
5. DESIGN SPECIFICATION
AASHTO Standard Specifications for Highway Bridges (13th Edition 1993).
6. DESIGN LOAD

Dead Load:	Concrete	25.54 KN/m ³
	Fill Materials	17.66 KN/m ³
	Concrete Pavement	25.54 KN/m ³
Live Load:	Roadway Live Load	HS 20-44 (MS-18)
	Sidewalk Live Load	2.875 KN/m ²

Temperature Change:
Rise +10°, Fall -10°

Earthquake Load:
C = 0.12 with Reference to Relevant AASHTO Provisions and Applicable Code.

Other Loads: in accordance with 1993 AASHTO Specification.
7. MATERIALS

Steel for Superstructure:	Steel shall be Specified by JIS (Japanese Industrial Standard).
Concrete:	Concrete for Superstructure: $f_c = 28.4 \text{ MPa}$ Concrete for Substructure: $f_c = 20.7 \text{ MPa}$
Others:	Other Materials shall conform to ASTM

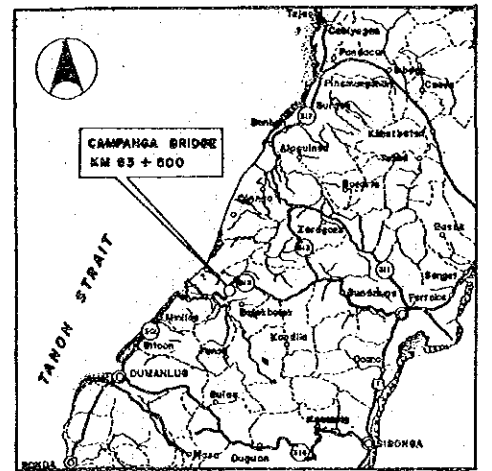

DRAWINGS
All Dimensions are expressed in millimeter unless otherwise shown in the plans.
All Elevations are in meters.

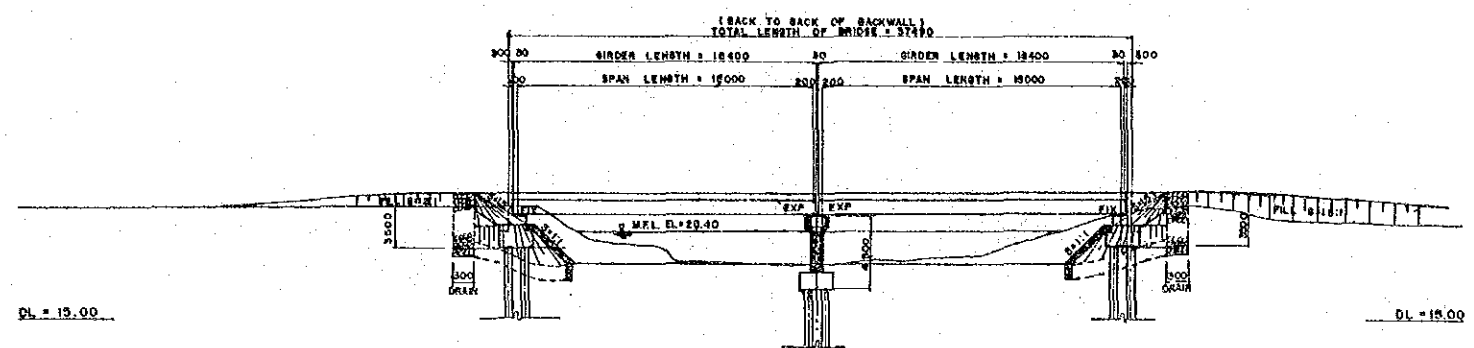

GENERAL ELEVATION
SCALE: 1:200

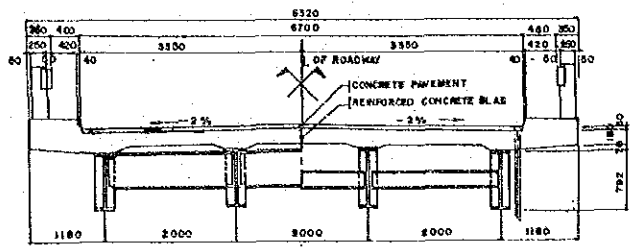

SUPERSTRUCTURE CROSS SECTION
SCALE: 1:50

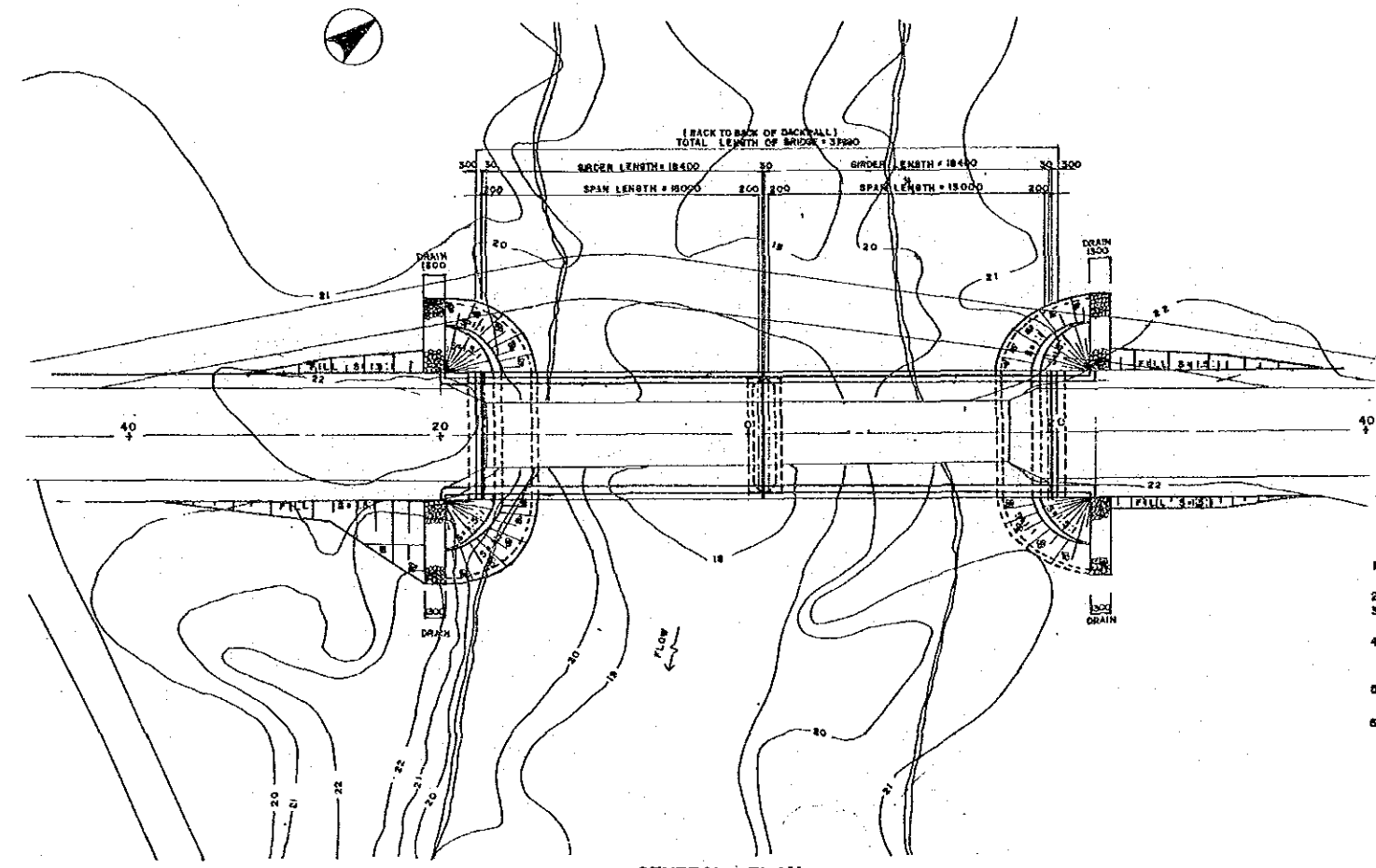

GENERAL PLAN
SCALE: 1:200

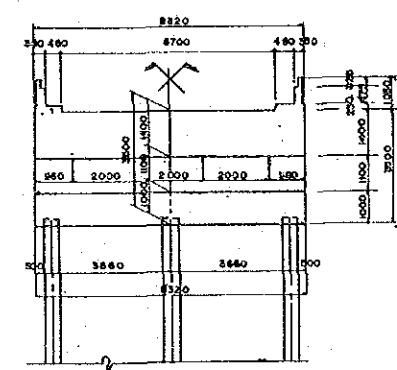

ABUTMENT

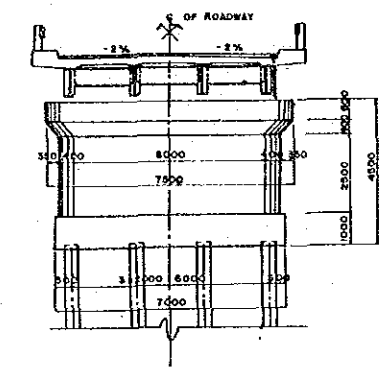

PIER

SUBSTRUCTURE CROSS SECTION
SCALE: 1:100

GENERAL NOTES

1. Location of bridge should be determined by the Department of Public Works and Highways (DPWH).
2. Structural dimensions of superstructures should not be amended.
3. Types and dimensions of substructures shall be justified according to the detailed design of substructures prepared by DPWH.
4. Vertical clearance between the M.F.L. and the bottom of the girders of the superstructure shall be not less than 1.0 meter (Carrying no big debris).
5. DESIGN SPECIFICATION
AASHTO Standard Specifications for Highway Bridges (13th Edition 1983)
6. DESIGN LOAD

Dead Load:	Concrete	23.54 KN/m ³
	Fill Material	17.66 KN/m ³
	Concrete Pavement	23.94 KN/m ³
Live Load:	Roadway Live Load	HS 20-44 (MS-18)
	Sidewalk Live Load	2.973 KN/m ²

Temperature Change:
Rise +10°, Fall -10°

Earthquake Load:
C = 0.12 with Reference to Relevant AASHTO Provisions and Applicable Code

Other Loads: in accordance with 1983 AASHTO Specification.
7. MATERIALS
Steel for Superstructure:
Steel shall be specified by JIS (Japanese Industrial Standard).
- Concrete:
Concrete for Superstructure $f_c = 29.4$ MPa
Concrete for Substructure $f_c = 20.7$ MPa
- Others:
Other Materials shall conform to ASTM

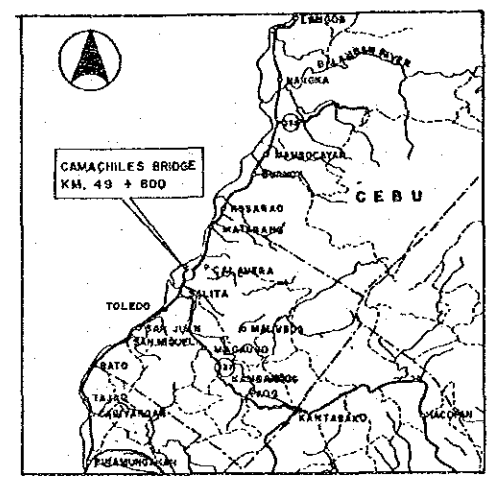

VICINITY MAP

DRAWINGS
All Dimensions are express in millimeter unless otherwise shown in the plans.
All Elevations are in metre.

BASIC DESIGN STUDY ON THE PROJECT
FOR CONSTRUCTING BRIDGES ALONG RURAL ROADS (PHASE I)

BRIDGE NO. 07-05	LAGNASON BRIDGE Km. 115 + 200	SHEET NO. 13/31
---------------------	----------------------------------	--------------------

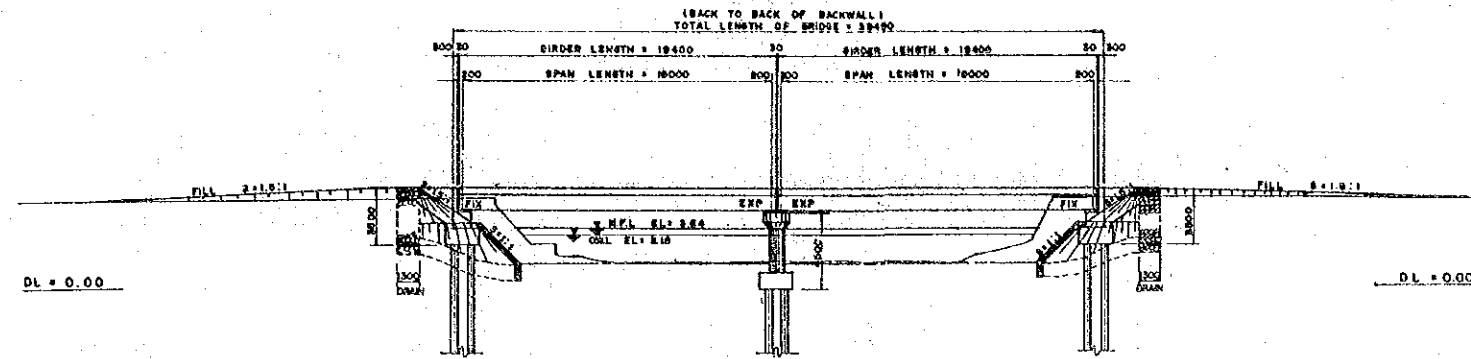

GENERAL ELEVATION
SCALE 1:200

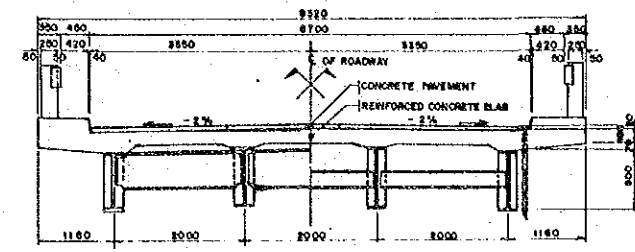

SUPERSTRUCTURE CROSS SECTION
SCALE 1:50

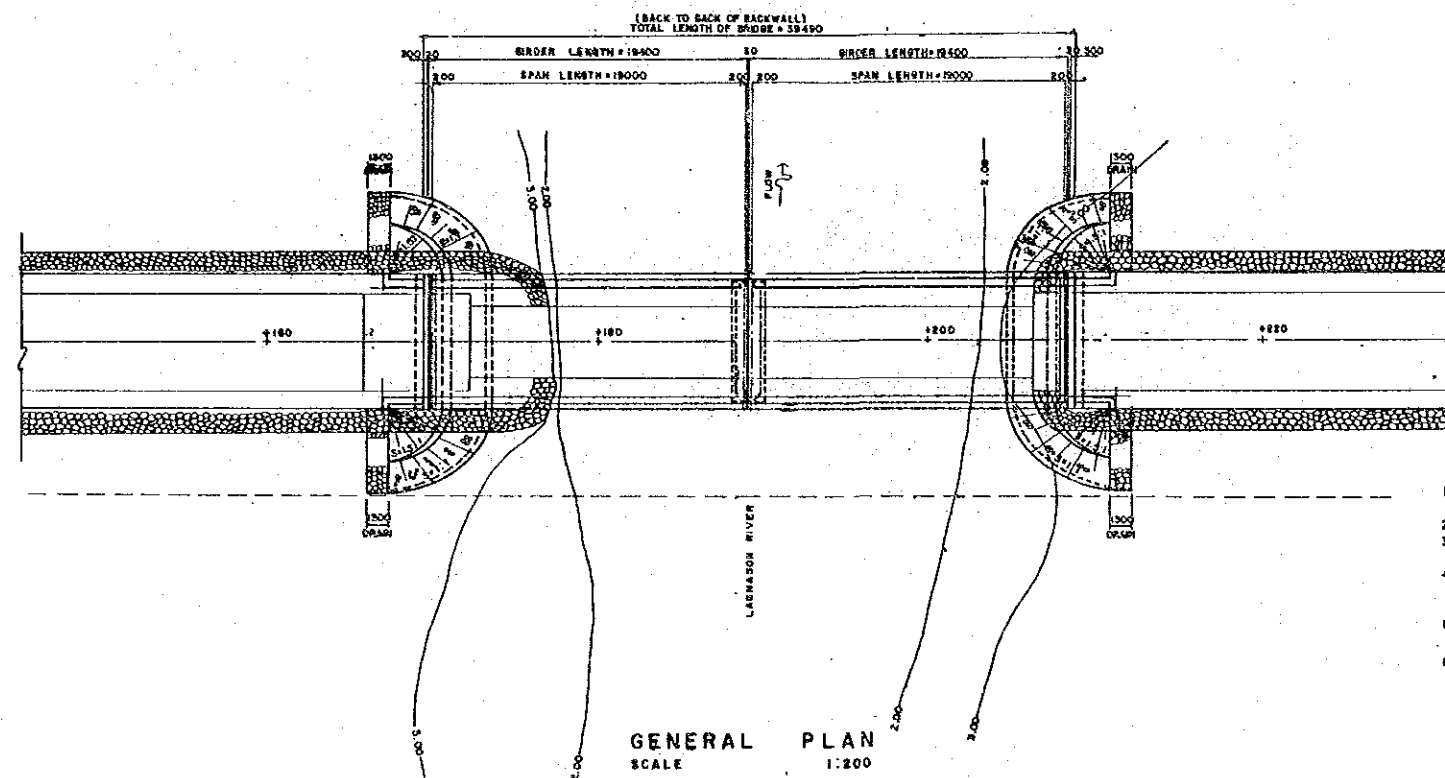

GENERAL PLAN
SCALE 1:200

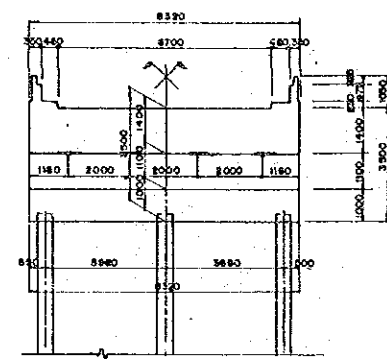

ABUTMENT

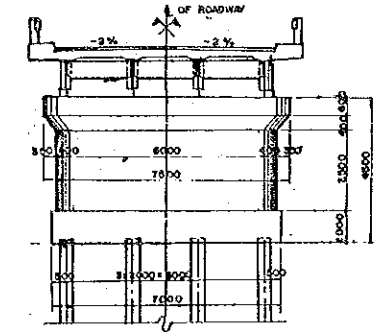

PIER

SUBSTRUCTURE CROSS SECTION
SCALE 1:100

GENERAL NOTES

- Location of bridge should be determined by the Department of Public Works and Highways (DPWH).
- Structural dimensions of superstructures should not be amended.
- Types and dimensions of substructures shall be justified according to the detailed design of substructures prepared by DPWH.
- Vertical clearance between the M.F.L. and the bottom of the girders of the superstructure shall be not less than 1.0 meter (Carrying no big debris).
- DESIGN SPECIFICATION
AASHTO Standard Specifications for Highway Bridges (13th Edition 1985)
- DESIGN LOAD

Dead Load:	Concrete	23.54 KN/m ³
	Fill Materials	17.68 KN/m ³
	Concrete Pavement	23.54 KN/m ³
Live Load:	Roadway Live Load	H.S. 20-44 (MS-1B)
	Sidewalk Live Load	2.875 KN/m ²
- TEMPERATURE CHANGE: Rise +10°, Fall -10°
- EARTHQUAKE LOAD: C = 0.12 with Reference to Relevant AASHTO Provisions and Applicable Codes
- OTHER LOADS: In accordance with 1985 AASHTO Specification.
- MATERIALS

Steel for Superstructure:	Steel shall be specified by JIS (Japanese Industrial Standard).
Concrete:	Concrete for Superstructure f _c ' = 29.4 MPa
	Concrete for Substructure f _c ' = 20.7 MPa
Others:	Other Materials shall conform to ASTM

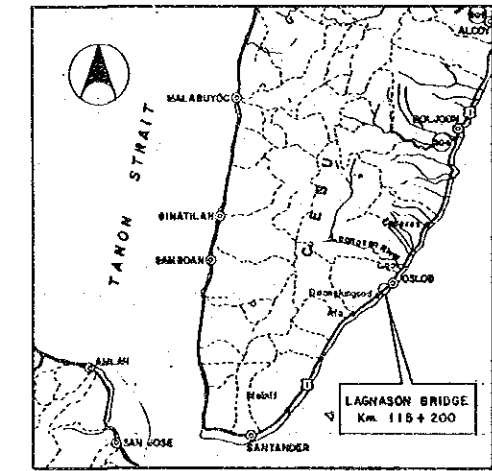

VICINITY MAP

DRAWINGS
All Dimensions are expressed in millimeter unless otherwise shown in the plans.
All Elevations are in meters.

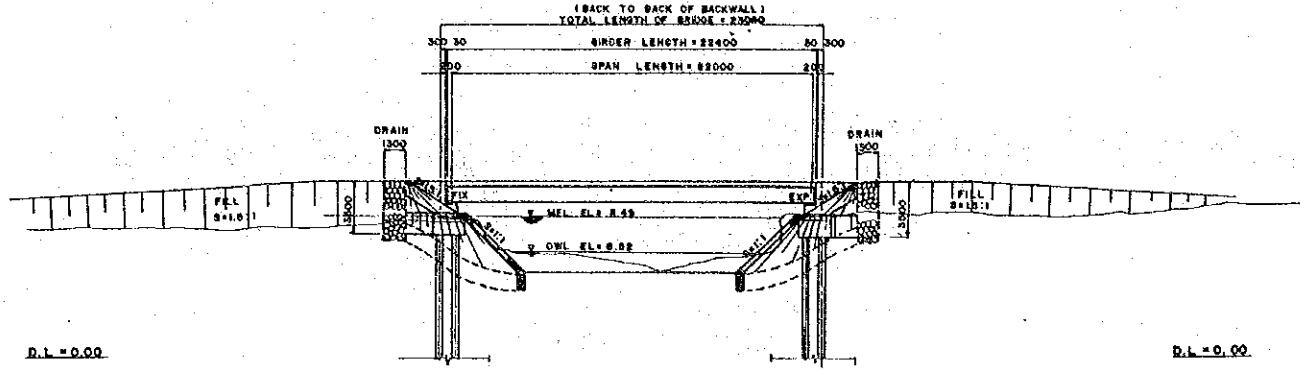

GENERAL ELEVATION
SCALE: 1:200

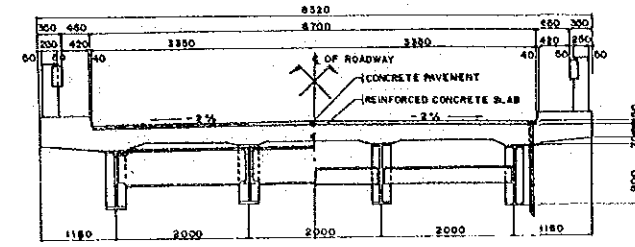

SUPERSTRUCTURE CROSS SECTION
SCALE: 1:50

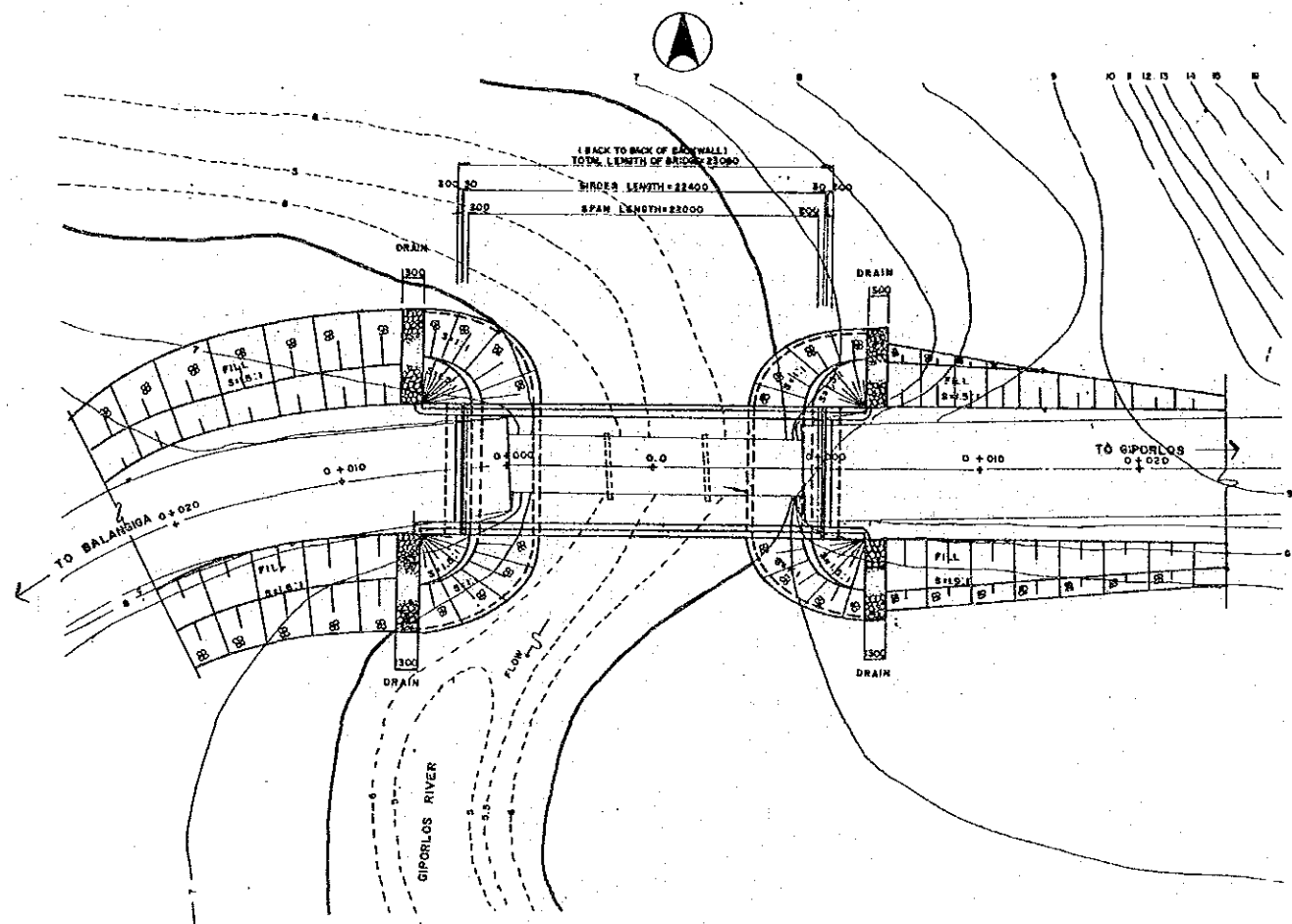

GENERAL PLAN
SCALE: 1:200

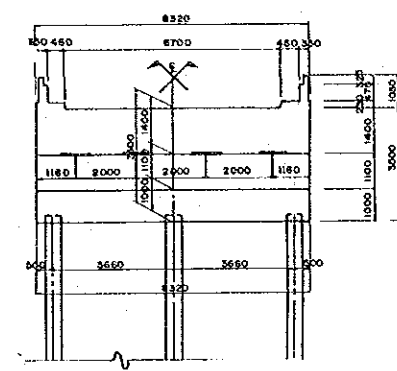

SUBSTRUCTURE CROSS SECTION
SCALE: 1:100

GENERAL NOTES

1. Location of bridges should be determined by the Department of Public Works and Highways (DPWH).
2. Structural dimensions of superstructures should not be amended.
3. Types and dimensions of substructures shall be justified according to the detailed design of substructures prepared by DPWH.
4. Vertical clearance between the M.F.L. and the bottom of the girders of the superstructure shall be not less than 1.0 meter (Carrying no big debris).
5. DESIGN SPECIFICATION
AASHTO Standard Specifications for Highway Bridges (13th Edition 1983)
6. DESIGN LOAD

Dead Load: Concrete	23.54 KN/m ²
Fill Materials	17.66 KN/m ²
Concrete Pavement	23.54 KN/m ²
Live Load: Roadway Live Load	HS20-44 (MS-M)
Sidewalk Live Load	2.873 KN/m ²
Temperature Change:	Rise +10°, Fall -10°
Earthquake Load:	C=0.12 with Reference to Relevant AASHTO Provisions and Applicable Code.
Other Loads:	In accordance with 1983 AASHTO Specification.
7. MATERIALS

Steel for Superstructure:	Steel shall be Specified by JIS (Japanese Industrial Standard).
Concrete:	Concrete for Superstructure f _c ' = 29.4 MPa Concrete for Substructure f _c ' = 20.7 MPa
Others:	Other Materials shall conformed to ASTM

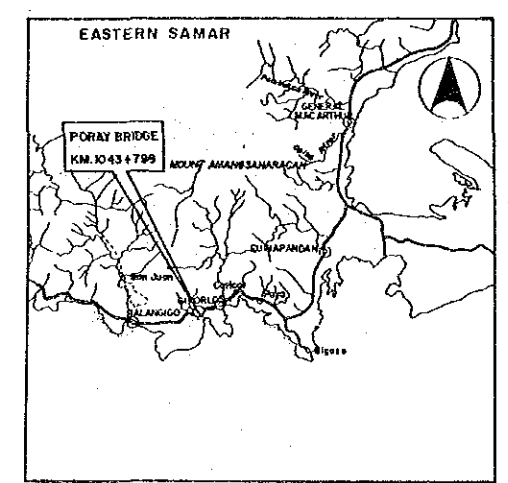

DRAWINGS
All Dimensions are express in millimeter unless otherwise shown in the plans.
All Elevations are in meters.

BASIC DESIGN STUDY ON THE PROJECT
FOR CONSTRUCTING BRIDGES ALONG RURAL ROADS (PHASE I)

BRIDGE NO.	IBA BRIDGE Km. 914 + 800	SHEET NO.
08-02		15/31

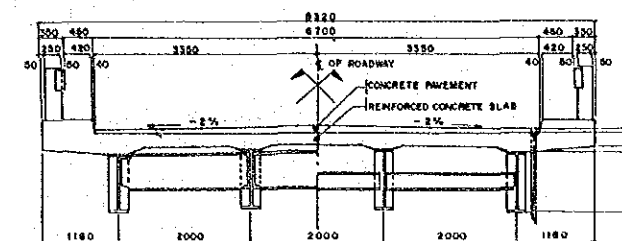
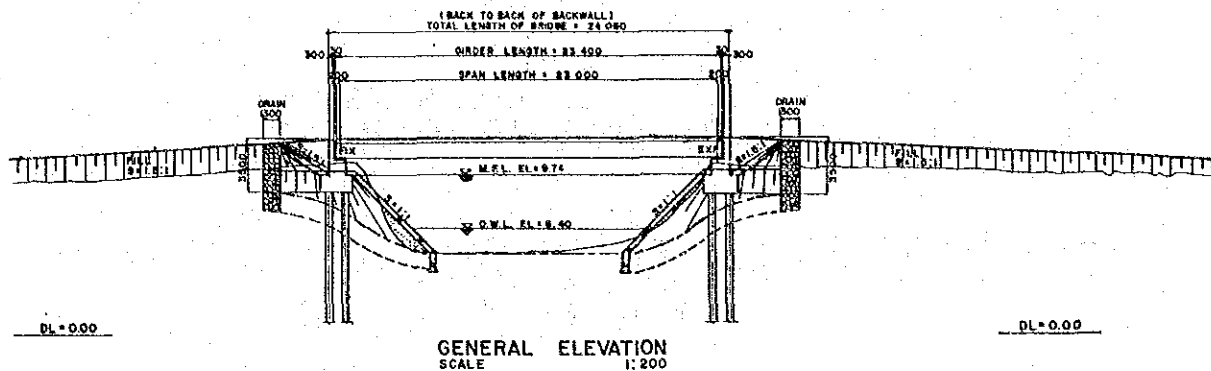

SUPERSTRUCTURE CROSS SECTION
SCALE: 1:60

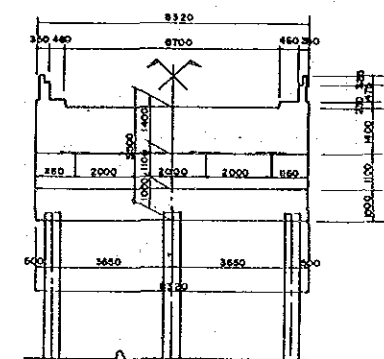
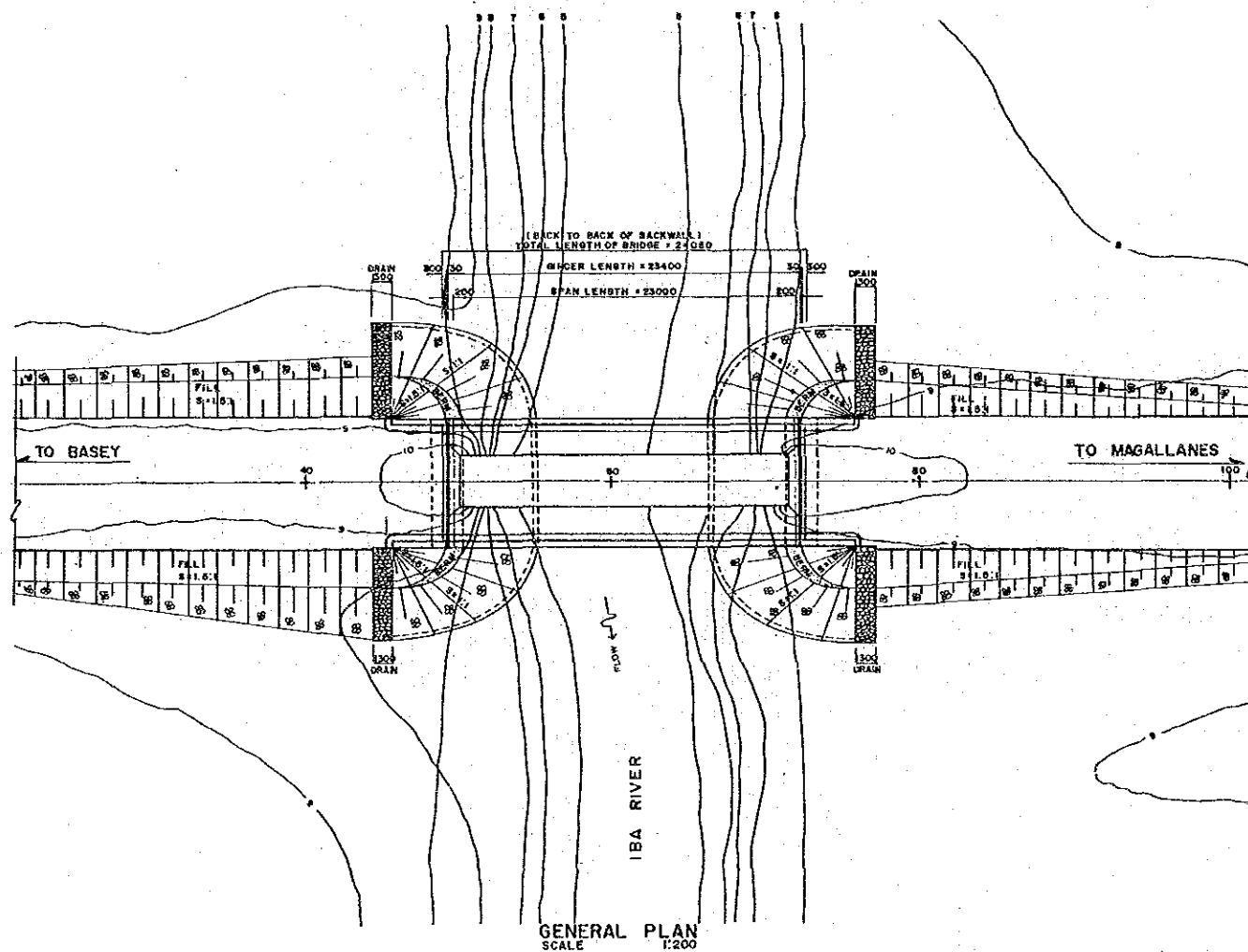

SUBSTRUCTURE CROSS SECTION
SCALE 1:100

GENERAL NOTES

- Location of bridge should be determined by the Department of Public Works and Highways (DPWH).
- Structural dimensions of superstructures should not be amended.
- Types and dimensions of substructures shall be justified according to the detailed design of substructures prepared by DPWH.
- Vertical clearance between the M.F.L. and the bottom of the girders of the superstructure shall be not less than 1.0 meter (Carrying no big debris).
- DESIGN SPECIFICATION
AASHTO Standard Specifications for Highway Bridges (13th Edition 1993)
- DESIGN LOAD

Dead Load:	Concrete	23.54 KN/m ³
	FIB Materials	17.66 KN/m ³
	Concrete Pavement	23.54 KN/m ³
Live Load:	Roadway Live Load	HS20-44 (HS-18)
	Sidewalk Live Load	2.673 KN/m ²

Temperature Change:
Rise +10°, Fall -10°

Earthquake Load:
C = 0.12 with Reference to Relevant AASHTO Provisions and Applicable Code.

Other Loads: in accordance with 1983 AASHTO Specification.
- MATERIALS

Steel for Superstructure:	Steel shall be Specified by JIS (Japanese Industrial Standard).
Concrete:	Concrete for Superstructure f _c ' = 29.4 MPa Concrete for Substructure f _c ' = 20.7 MPa Other Materials shall conform to ASTM

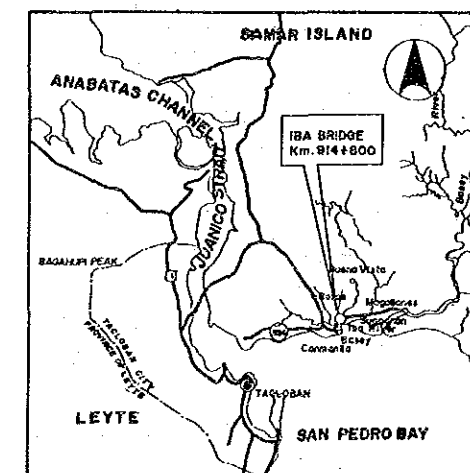

VICINITY MAP

DRAWINGS:
All Dimensions are express in millimeter unless otherwise shown in the plans.
All Elevations are in meters.

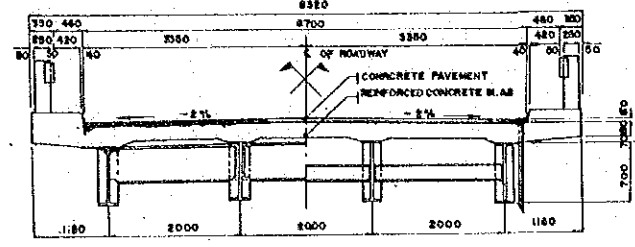
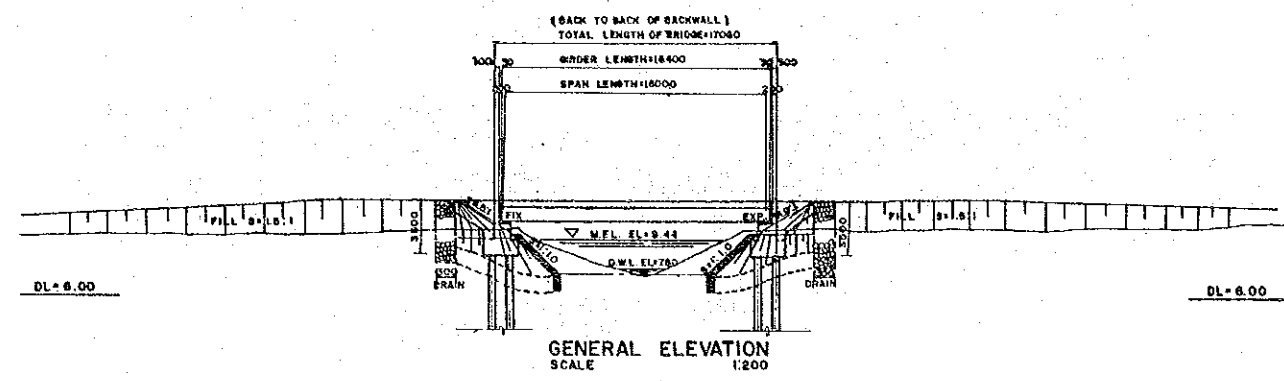

SUPERSTRUCTURE CROSS SECTION
SCALE: 1:50

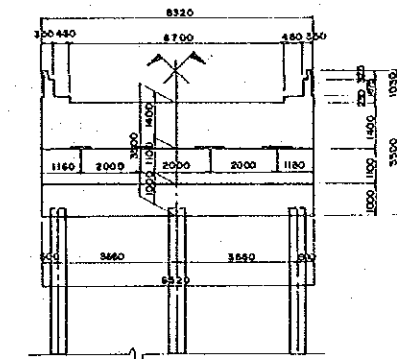
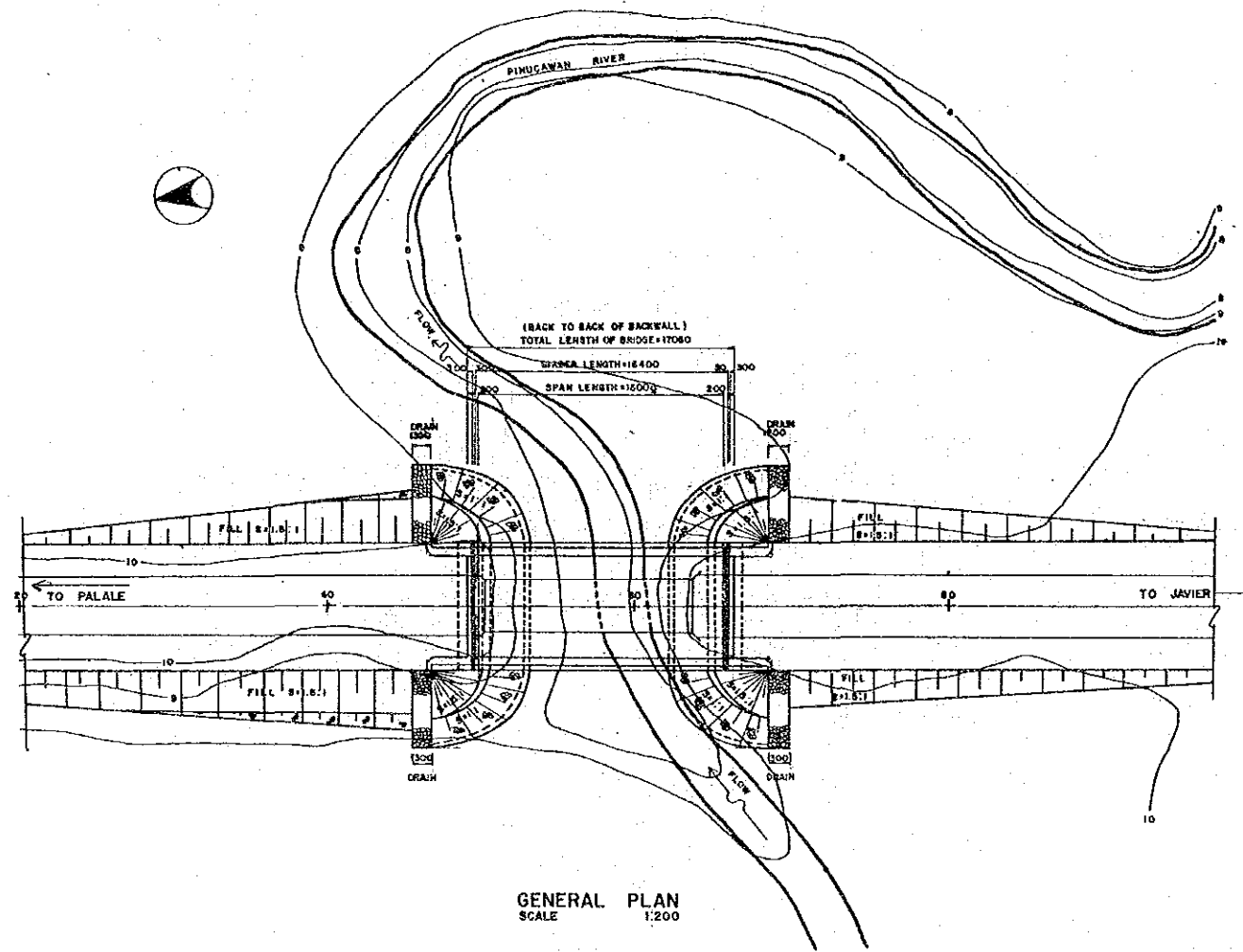

SUBSTRUCTURE CROSS SECTION
SCALE: 1:100

GENERAL NOTES

1. Location of bridge should be determined by the Department of Public Works and Highways (DPWH).
2. Structural dimensions of superstructures should not be amended.
3. Types and dimensions of substructures shall be justified according to the detailed design of substructures prepared by DPWH.
4. Vertical clearance between the M.F.L. and the bottom of the girders of the superstructure shall be not less than 1.0 meter (Carrying no big debris).
5. DESIGN SPECIFICATION
AASHTO Standard Specifications for Highway Bridges (15th Edition 1983)
6. DESIGN LOAD

Dead Load:	Concrete	25.54 KN/m ³
	FIR Materials	17.66 KN/m ³
	Concrete Pavement	23.04 KN/m ³
Live Load:	Roadway Live Load	HS 20-44 (MS-18)
	Sidewalk Live Load	2.875 KN/m ²

Temperature Change:
Rise +10°, Fall -10°

Earthquake Load:
C = 0.12 with Reference to Relevant AASHTO Provisions and Applicable Code.

Other Loads: In accordance with 1983 AASHTO Specification.
7. MATERIALS

Steel for Superstructure:	Steel shall be Specified by JIS (Japanese Industrial Standard)
Concrete:	Concrete for Superstructure f _c ' = 29.4 MPa Concrete for Substructure f _c ' = 20.7 MPa
Others:	Other Materials shall conform to ASTM

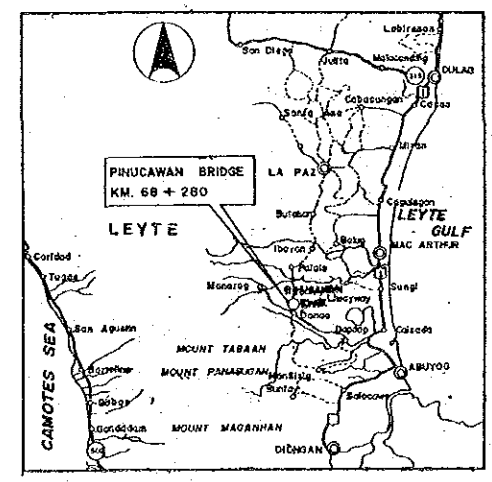

DRAWINGS
All Dimensions are expressed in millimeter unless otherwise shown in the plans.
All Elevations are in meters.

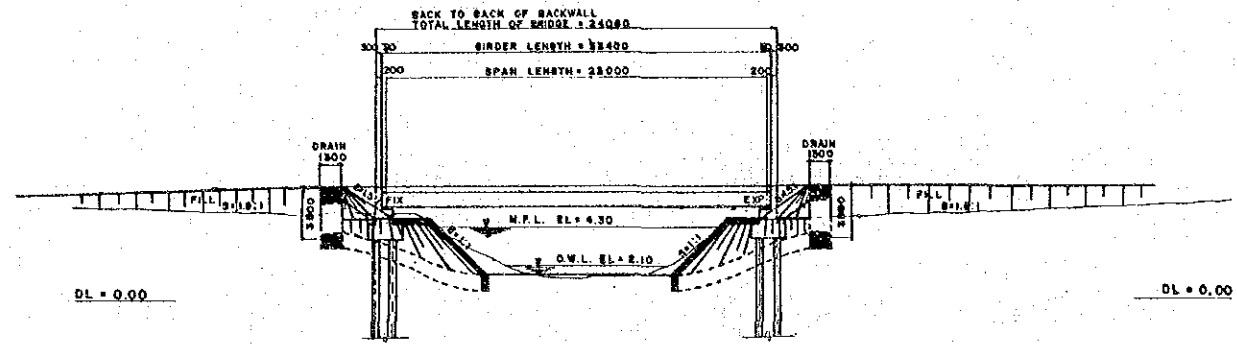

GENERAL ELEVATION
SCALE: 1:200

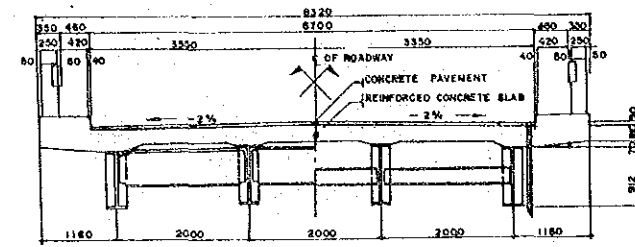

SUPERSTRUCTURE CROSS SECTION
SCALE: 1:50

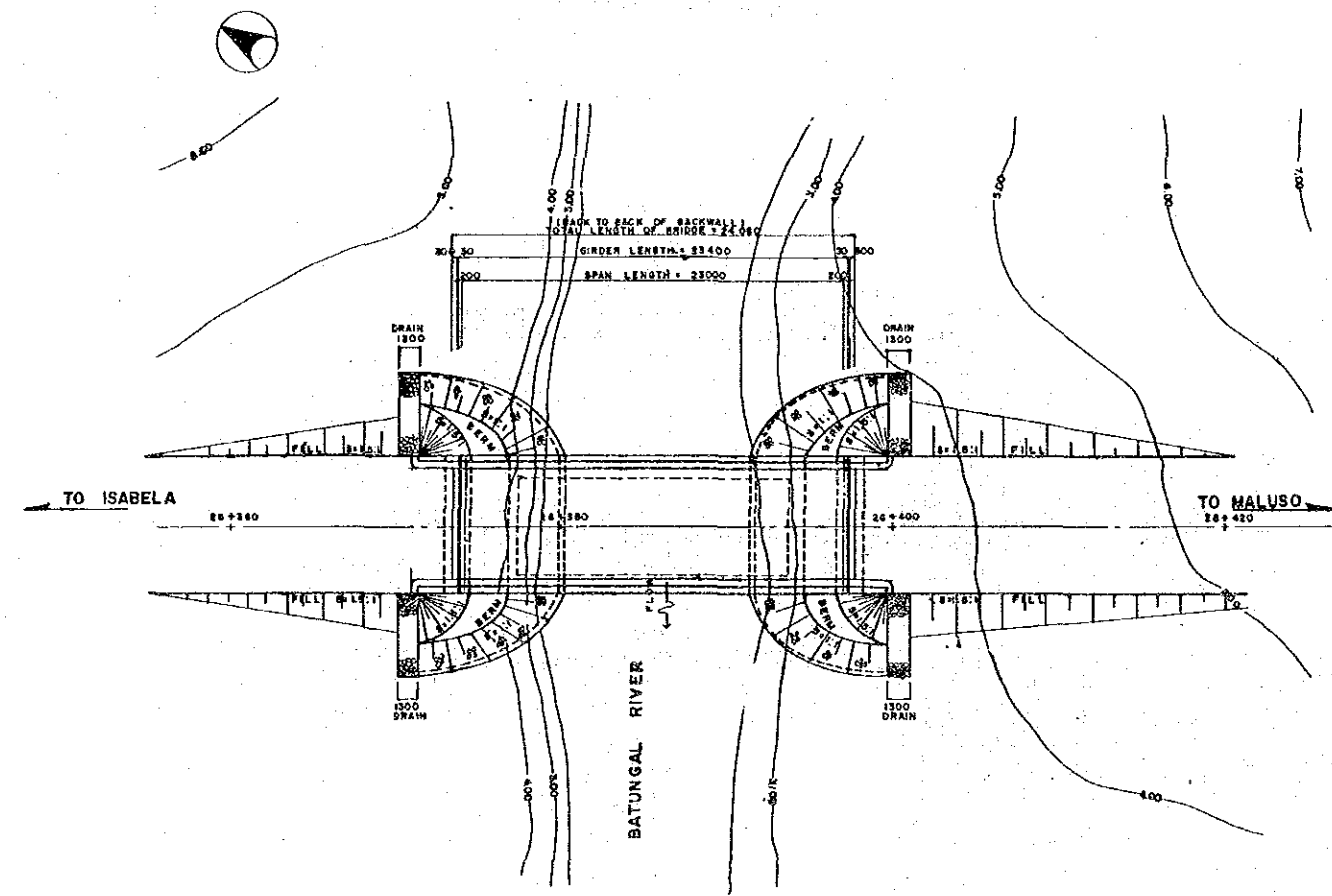

GENERAL PLAN
SCALE: 1:200

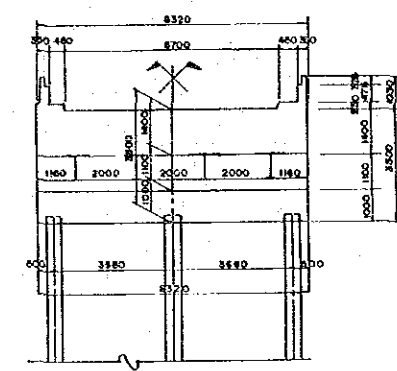

SUBSTRUCTURE CROSS SECTION
SCALE: 1:100

GENERAL NOTES

1. Location of bridge should be determined by the Department of Public Works and Highways (DPWH).
2. Structural dimensions of superstructures should not be amended.
3. Types and dimensions of substructures shall be justified according to the detailed design of substructures prepared by DPWH.
4. Vertical clearance between the M.F.L. and the bottom of the girders of the superstructure shall be not less than 1.0 meter (Carrying no big debris).
5. DESIGN SPECIFICATION
AASHTO Standard Specifications for Highway Bridges (13th Edition 1963)
6. DESIGN LOAD

Dead Load:	Concrete	23.84 KN/m ³
	Fill Material	17.88 KN/m ³
	Concrete Pavement	23.84 KN/m ³
Live Load:	Roadway Live Load	HS 20-44 (HS-19)
	Sidewalk Live Load	9.875 KN/m
Temperature Change:	Rise	+10°
	Fall	-10°
Earthquake Load:		C = 0.12 with Reference to Relevant AASHTO Provisions and Applicable Code
Other Loads:		In accordance with 1983 AASHTO Specification
7. MATERIALS

Steel for Superstructure	Steel shall be specified by JIS (Japanese Industrial Standard).
Concrete:	Concrete for Superstructure $f_c = 29.4 \text{ MPa}$
	Concrete for Substructure $f_c = 20.7 \text{ MPa}$
Others:	Other Materials shall conform to ASTM

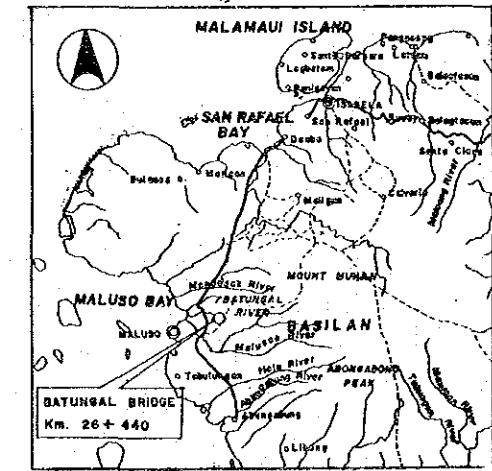

VICINITY MAP

DRAWINGS
All Dimensions are expressed in millimeter unless otherwise shown in the plans
All Elevations are in meters.

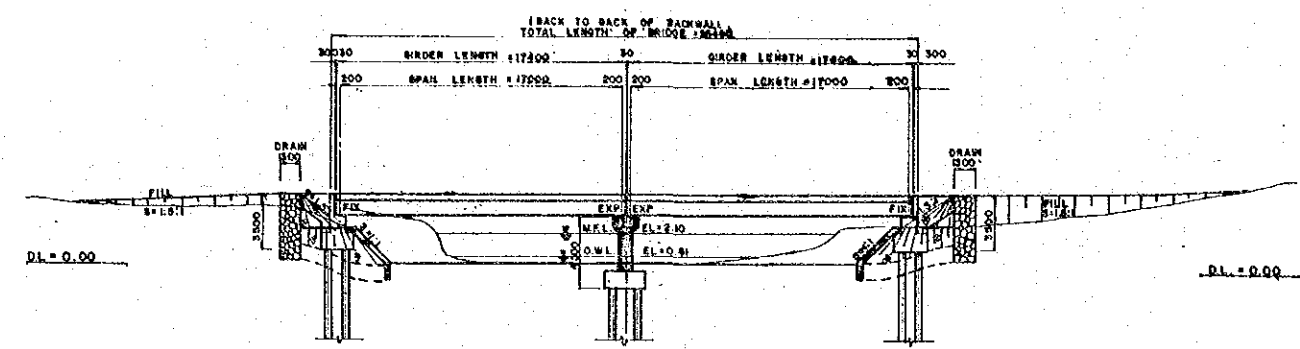

GENERAL ELEVATION
SCALE 1:200

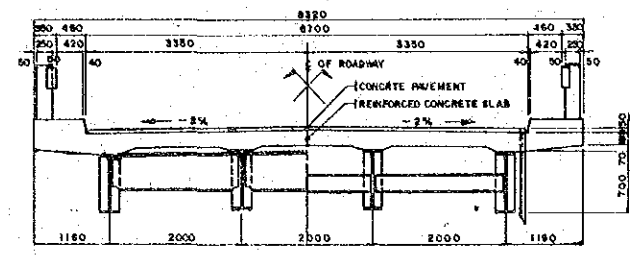

SUPERSTRUCTURE CROSS SECTION
SCALE 1:50

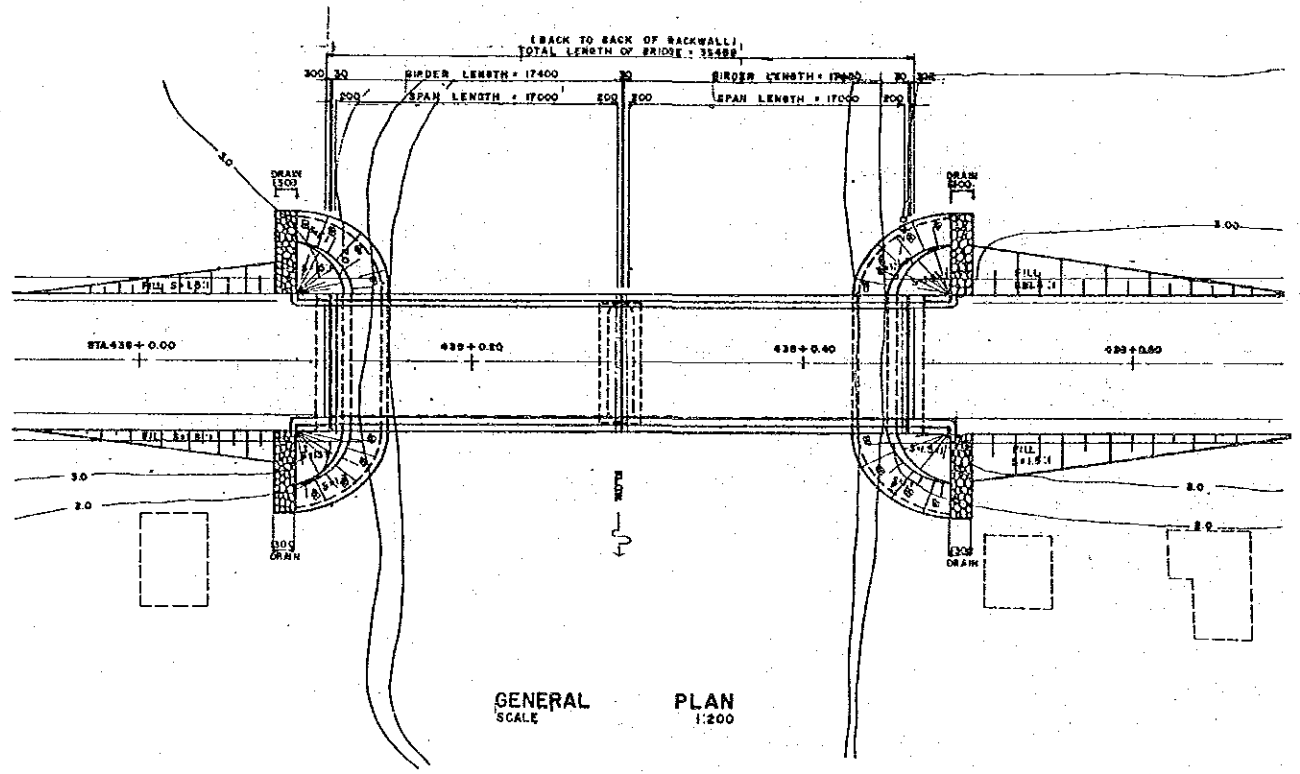

GENERAL PLAN
SCALE 1:200

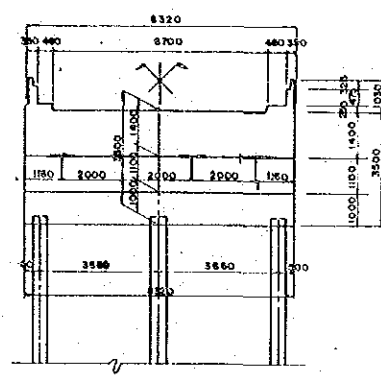

ABUTMENT

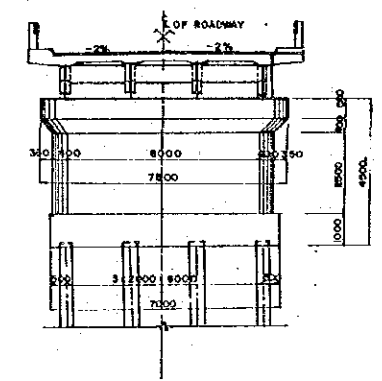

PIER

SUBSTRUCTURE CROSS SECTION
SCALE 1:100

GENERAL NOTES

1. Location of bridge should be determined by the Department of Public Works and Highway (DPWH).
2. Structural dimensions of superstructures should not be amended.
3. Types and dimensions of substructures shall be justified according to the detailed design of substructures prepared by DPWH.
4. Vertical clearance between the M.F.L. and the bottom of the girders of the superstructure shall be not less than 1.0 meter (Carrying no big debris).
5. DESIGN SPECIFICATION
AASHTO Standard Specifications for Highway Bridges (18th Edition 1983)
6. DESIGN LOAD

Dead Load: Concrete	23.54 KN/m ³
Fill Materials	17.66 KN/m ³
Concrete Pavement	23.54 KN/m ³
Live Load: Roadway Live Load	HS 20-44 (MS-18)
Sidewalk Live Load	2.873 KN/m ²
7. MATERIALS

Steel for Superstructure:	Steel shall be Specified by JIS (Japanese Industrial Standard).
Concrete:	Concrete for Superstructure f _c ' = 28.4 MPa
	Concrete for Substructure f _c ' = 20.7 MPa
Others:	Other Materials shall conform to ASTM

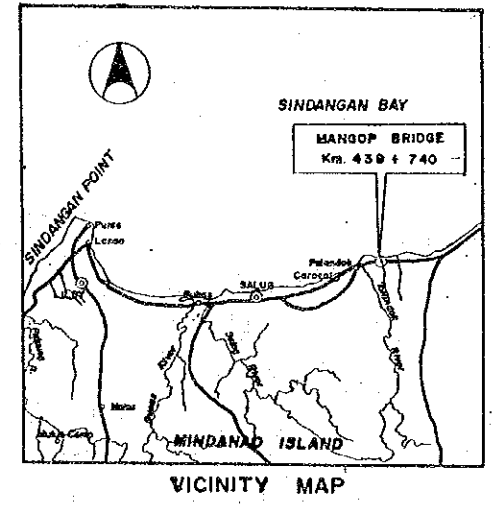

VICINITY MAP

DRAWINGS
All Dimensions are express in millimeter unless otherwise shown in the plans.
All Elevations are in meters.

BASIC DESIGN STUDY ON THE PROJECT
FOR CONSTRUCTING BRIDGES ALONG RURAL ROADS (PHASE I)

BRIDGE NO.	CANAWAN BRIDGE Km. 449 + 740	SHEET NO.
09-03		19/31

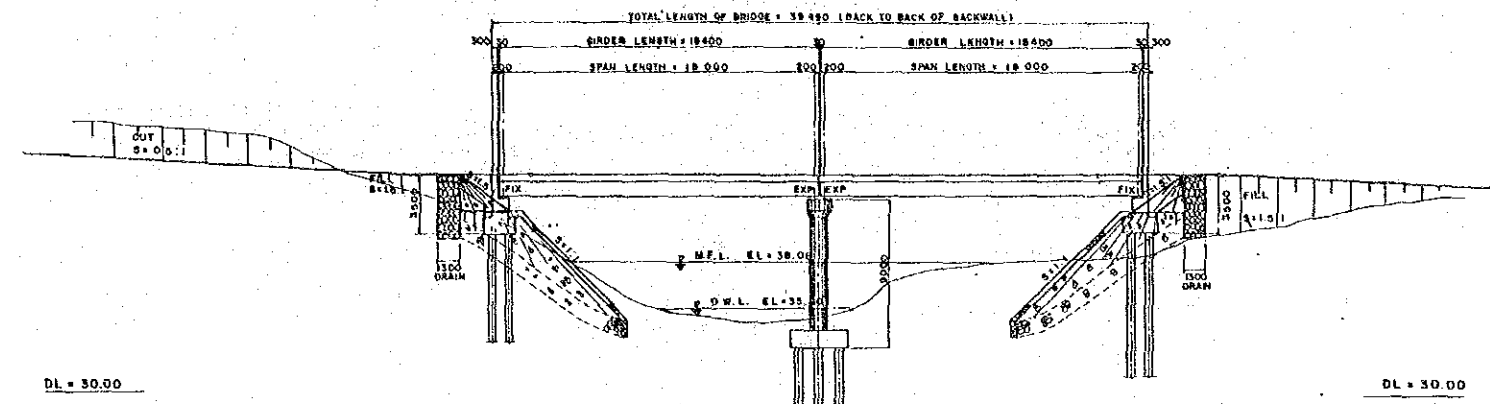

DL = 30.00

DL = 30.00

GENERAL ELEVATION
SCALE: 1:200

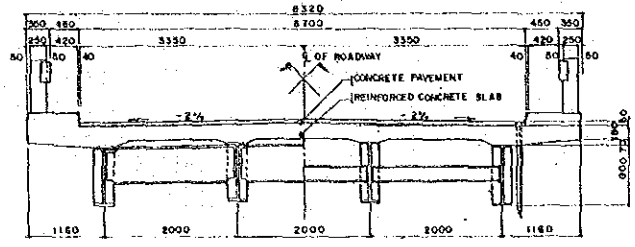

SUPERSTRUCTURE CROSS SECTION
SCALE: 1:50

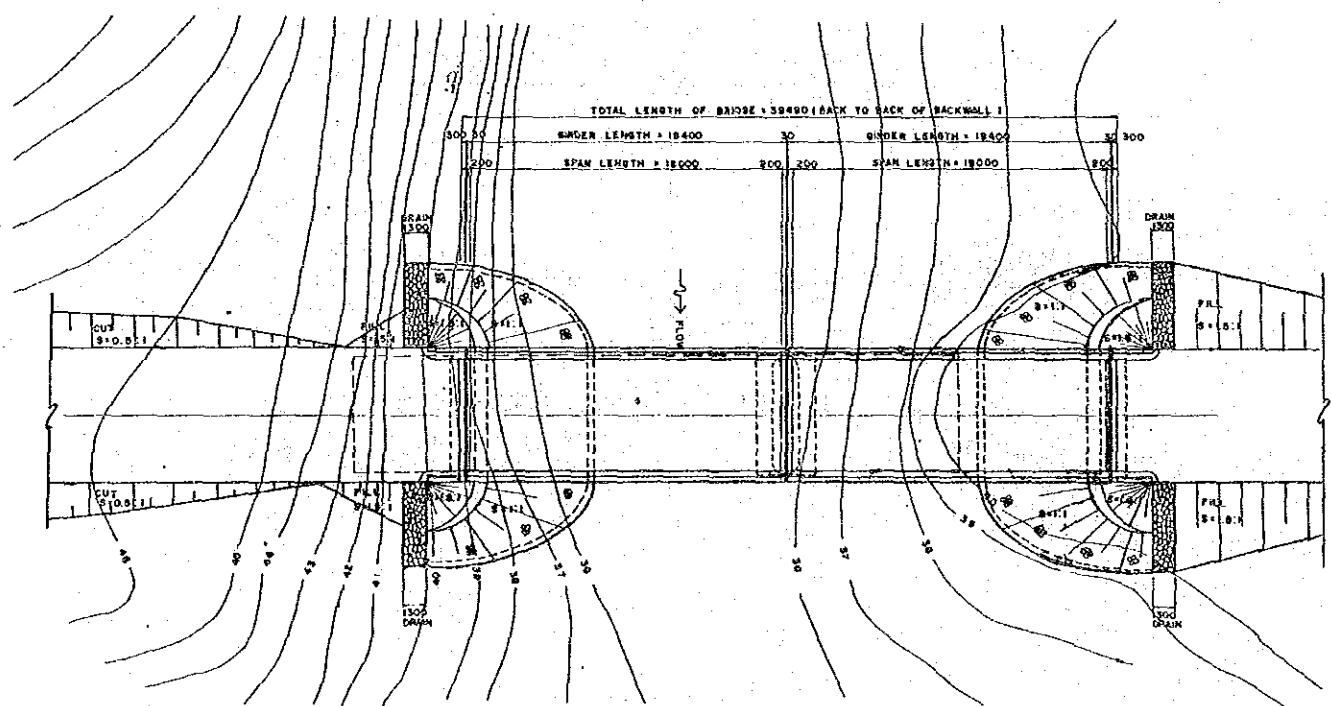

GENERAL PLAN
SCALE: 1:200

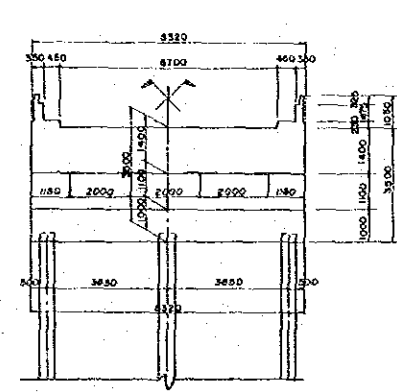

ABUTMENT

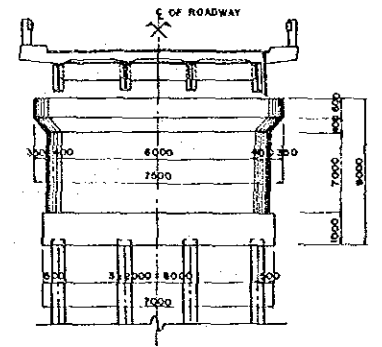

PIER

SUBSTRUCTURE CROSS SECTION
SCALE: 1:100

GENERAL NOTES

- Location of bridge should be determined by the Department of Public Works and Highways (DPWH).
- Structural dimensions of superstructures should not be amended.
- Type and dimensions of substructures shall be justified according to the detailed design of substructures prepared by DPWH.
- Vertical clearance between the M.F.L. and the bottom of the girders of the superstructure shall be not less than 1.0 meter. (Carrying no big debris).
- DESIGN SPECIFICATION
AASHTO Standard Specifications for Highway Bridges (13th Edition 1983)
- DESIGN LOAD

Dead Load:	Concrete	23.54 KN/m
	Fill Materials	17.66 KN/m
	Concrete Pavement	23.54 KN/m
Live Load:	Roadway Live Load	HS20-44 (MS-18)
	Sidewalk Live Load	2,873 XN/m

Temperature Change:
Rise +10°, Fall -10°

Earthquake Load:
C=0.12 with Reference to Relevant AASHTO Provisions and Applicable Code.

Other Loads: In accordance with 1983 AASHTO Specification.
- MATERIALS

Steel for Superstructure:
Steel shall be Specified by JIS (Japanese Industrial Standard).

Concrete:
Concrete for Superstructure $f_c = 20.4$ MPa
Concrete for Substructure $f_c = 20.7$ MPa
Others: Other Materials shall conformed to ASTM

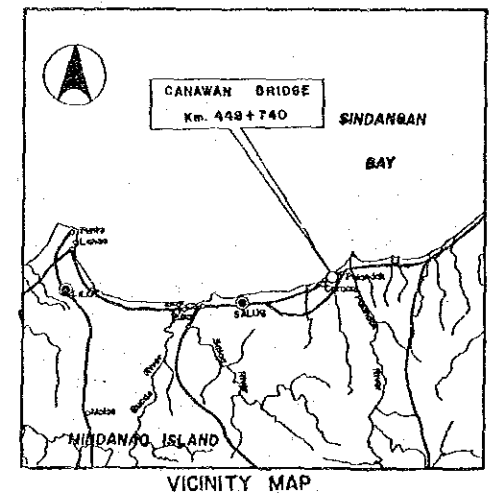

VICINITY MAP

DRAWINGS
All Dimensions are expressed in millimeter unless otherwise shown in the plans.
All Elevations are in meters.

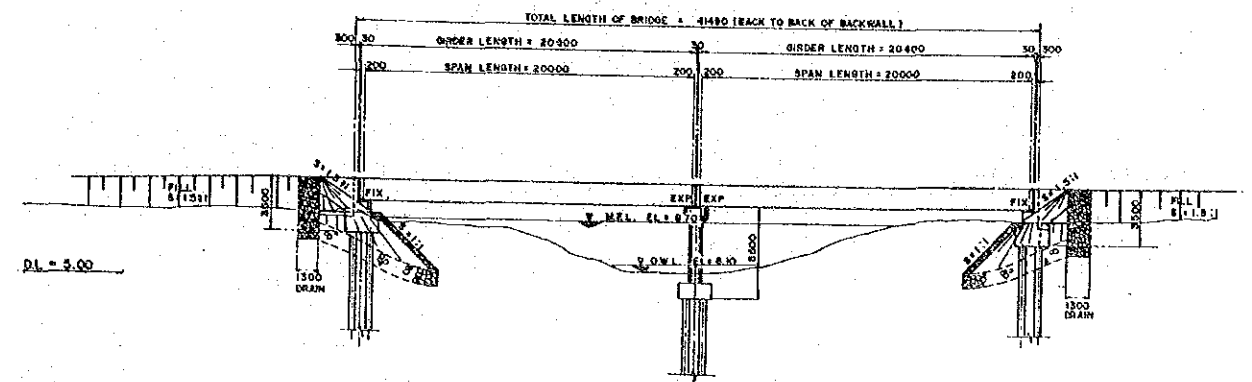

GENERAL ELEVATION
SCALE: 1:200

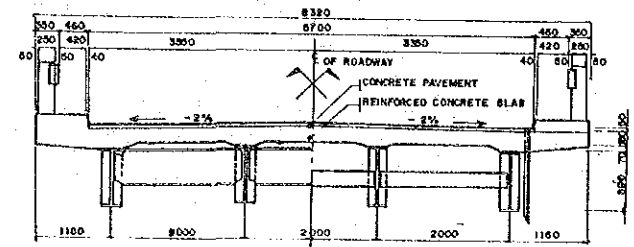

SUPERSTRUCTURE CROSS SECTION
SCALE: 1:50

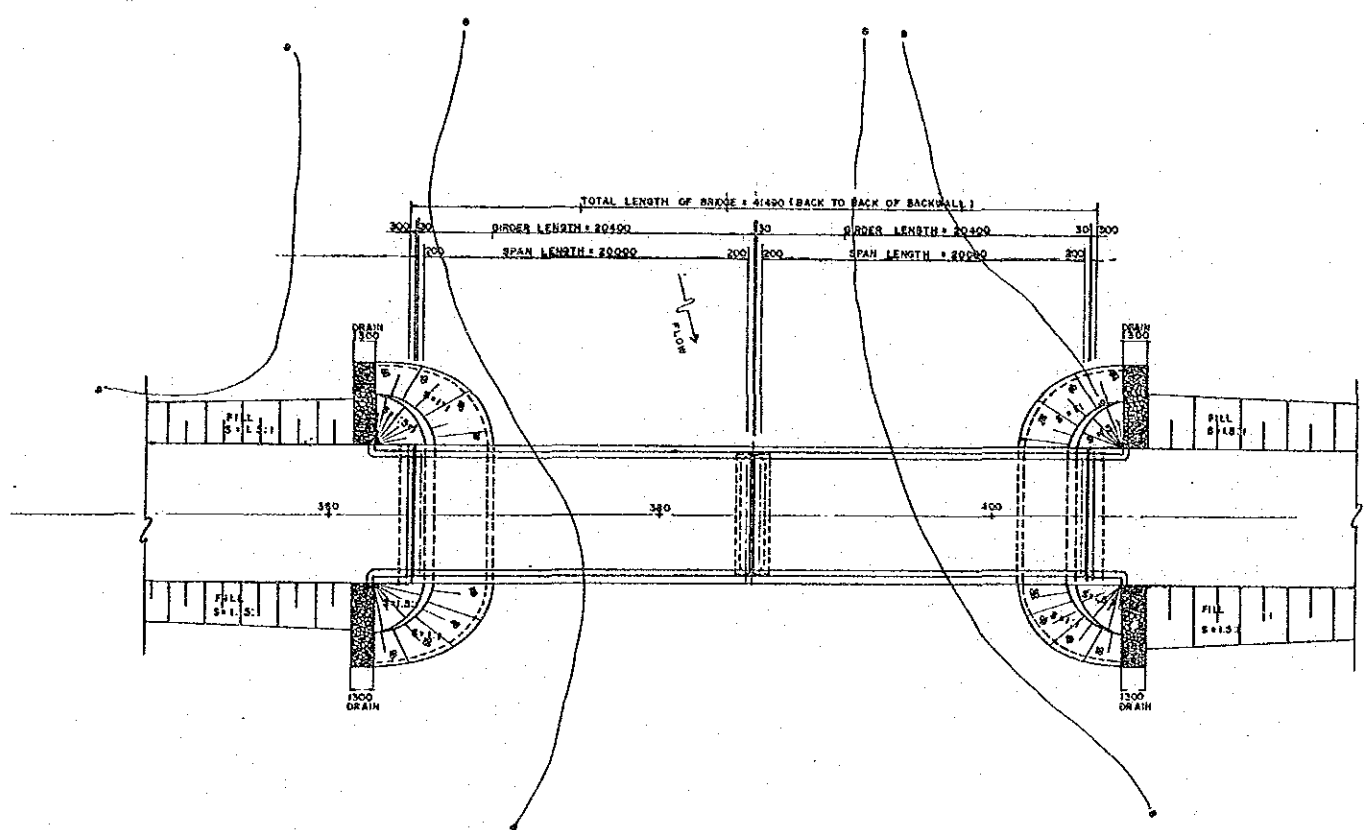

GENERAL PLAN
SCALE: 1:200

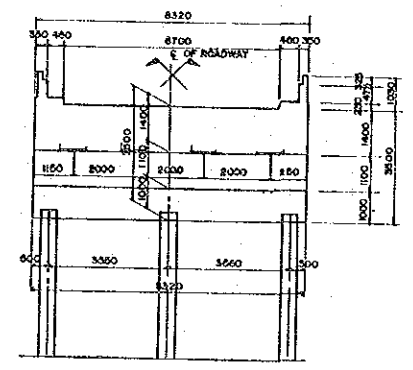

ABUTMENT

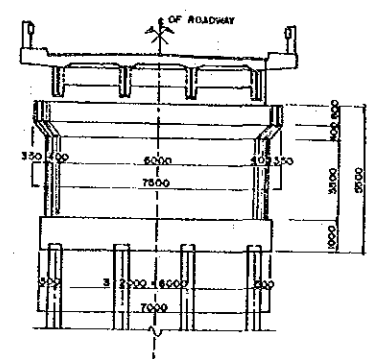

PIER

SUBSTRUCTURE CROSS SECTION
SCALE: 1:100

GENERAL NOTES

1. Location of bridge should be determined by the Department of Public Works and Highways (DPWH).
2. Structural dimensions of superstructures should not be amended.
3. Types and dimensions of substructures shall be justified according to the detailed design of substructures prepared by DPWH.
4. Vertical clearance between the M.F.L. and the bottom of the girder of the superstructure shall be not less than 1.0 meter (Carrying no big debris).
5. DESIGN SPECIFICATION
AASHTO Standard Specifications for Highway Bridges (15th Edition 1993)
6. DESIGN LOAD

Dead Load:	Concrete	23.54 KN/m ³
	Fill Materials	17.66 KN/m ³
	Concrete Pavement	23.54 KN/m ³
Live Load:	Roadway Live Load	HS20-44 (MS-18)
	Sidewalk Live Load	2.875 KN/m ²
Temperature Change:		Rise +10°, Fall -10°
Earthquake Load:		C = 0.12 with Reference to Relevant AASHTO Provisions and Applicable Code
Other Loads:		In accordance with 1993 AASHTO Specification.
7. MATERIALS
Steel for Superstructure:
Steel shall be Specified by JIS (Japanese Industrial Standard).
Concrete:
Concrete for Superstructure $f'_c = 29.4$ MPa
Concrete for Substructures $f'_c = 20.7$ MPa
Others:
Other Materials shall conform to ASTM

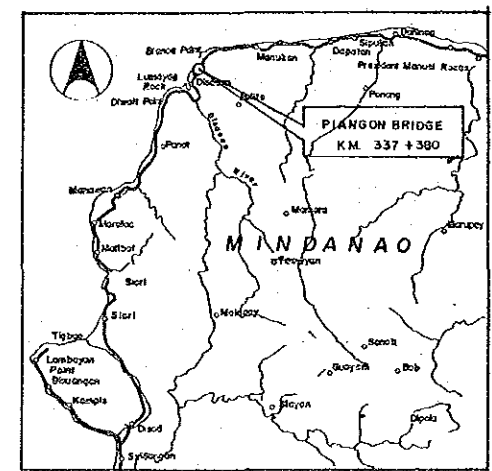

VICINITY MAP

DRAWINGS
All dimensions are expressed in millimeter unless otherwise shown in the plans.
All elevations are in meters.

BASIC DESIGN STUDY ON THE PROJECT FOR CONSTRUCTING BRIDGES ALONG RURAL ROADS (PHASE I)		
BRIDGE NO. 10-02	MARADUGAO BRIDGE Km. 1608 + 942	SHEET NO. 21/31

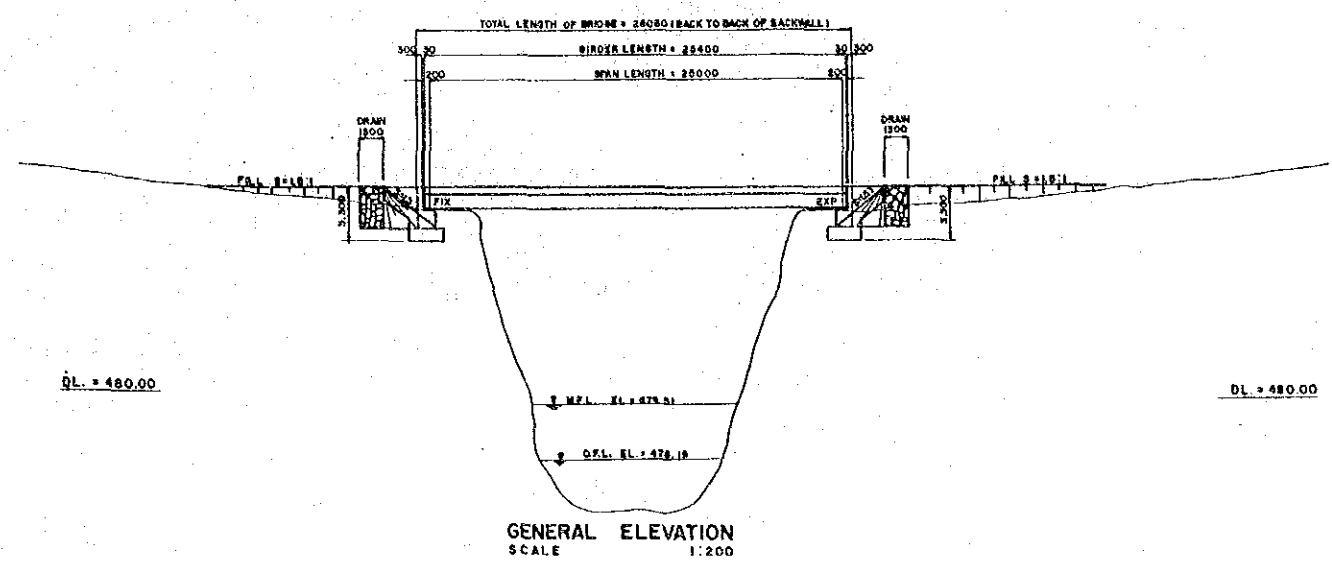

GENERAL ELEVATION
SCALE 1:200

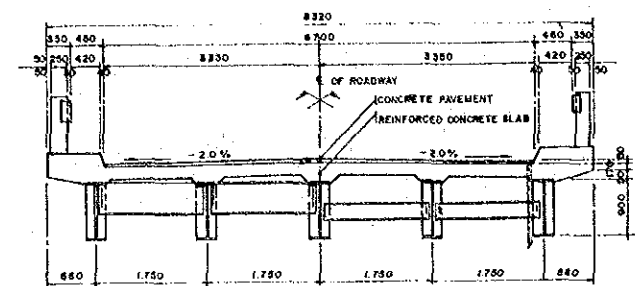

SUPERSTRUCTURE CROSS SECTION
SCALE 1:50

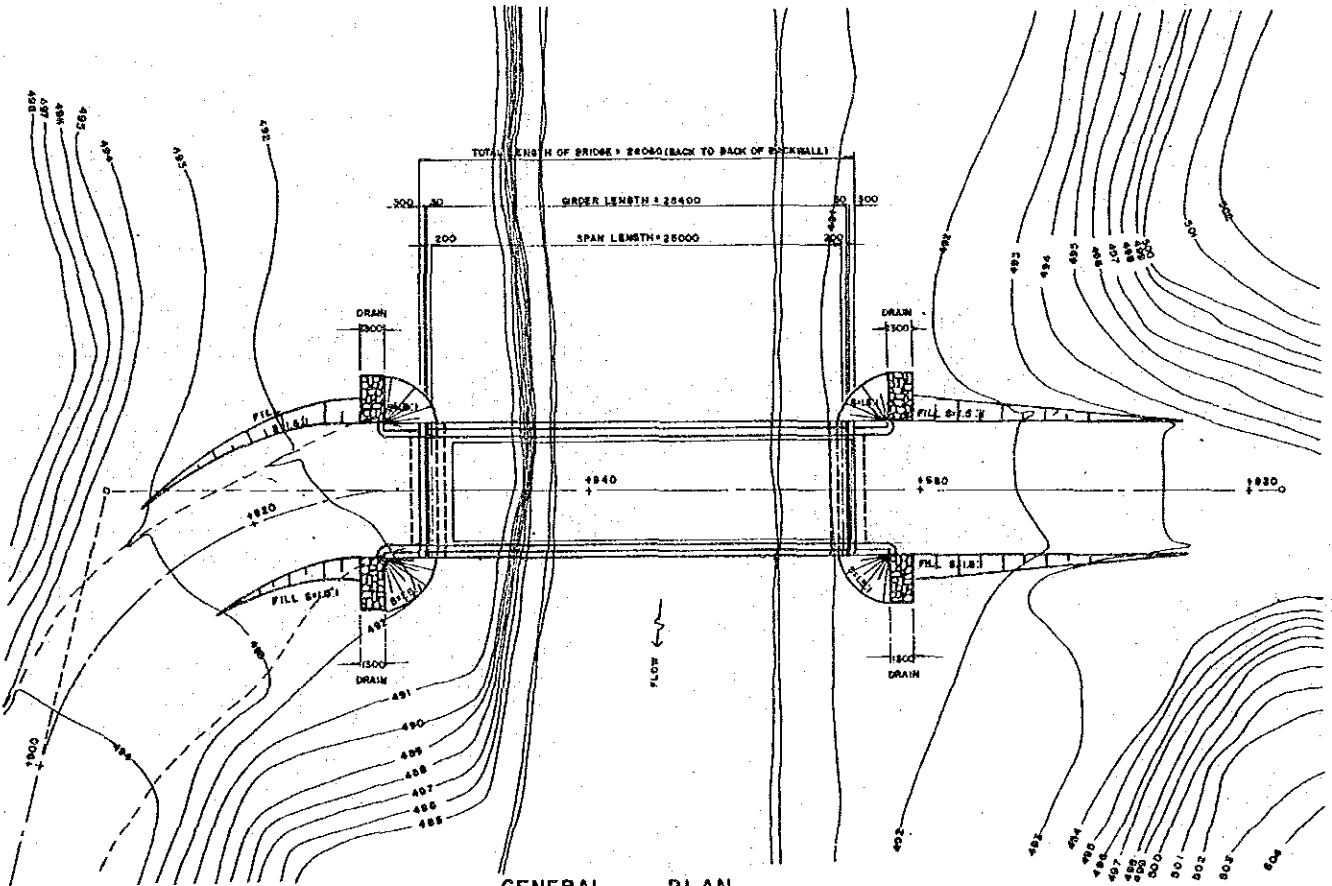

GENERAL PLAN
SCALE 1:200

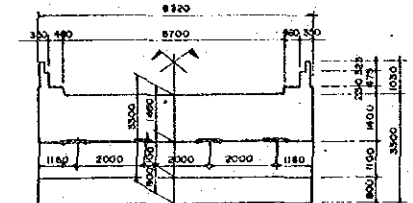

SUBSTRUCTURE CROSS SECTION
SCALE 1:100

GENERAL NOTES

1. Location of bridge should be determined by the Department of Public Works and Highways (DPWH).
2. Structural dimensions of superstructures should not be amended.
3. Types and dimensions of substructures shall be justified according to the detailed design of substructures prepared by DPWH.
4. Vertical clearance between the M.F.L. and the bottom of the girders of the superstructure shall be not less than 1.0 meter (Carrying no Hg debris).
5. DESIGN SPECIFICATION
AASHTO Standard Specifications for Highway Bridges (13th Edition 1963)
6. DESIGN LOAD

Dead Load:	Concrete	23.84 KN/m ³
	F18 Materials	17.66 KN/m ³
	Concrete Pavement	23.84 KN/m ³
Live Load:	Roadway Live Load	HS 20-44 (MS-18)
	Slowway Live Load	2.873 KN/m ²
Temperature Change:		Rise +10°, Fall -10°
Earthquake Load:		C = 0.12 with Reference to Relevant AASHTO Provisions and Applicable Code.

 Other Loads: in accordance with 1993 AASHTO Specification.
7. MATERIALS

Steel for Superstructure:	Steel shall be Specified by JIS (Japanese Industrial Standard).
Concrete:	Concrete for Superstructure f _c = 29.4 MPa Concrete for Substructure f _c = 20.7 MPa
Other:	Other Materials shall conform to ASTM

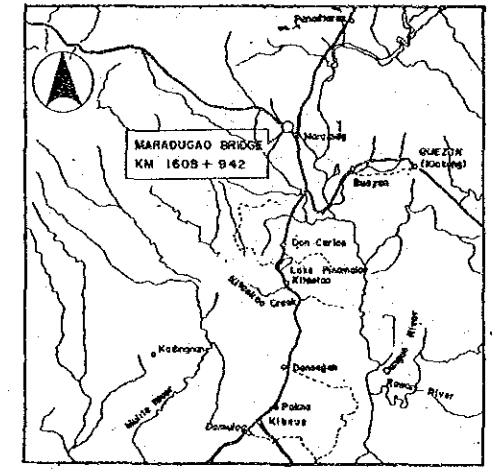

VICINITY MAP

DRAWINGS
All Dimensions are express in millimeter unless otherwise shown in the plans.
All Elevations are in meters.

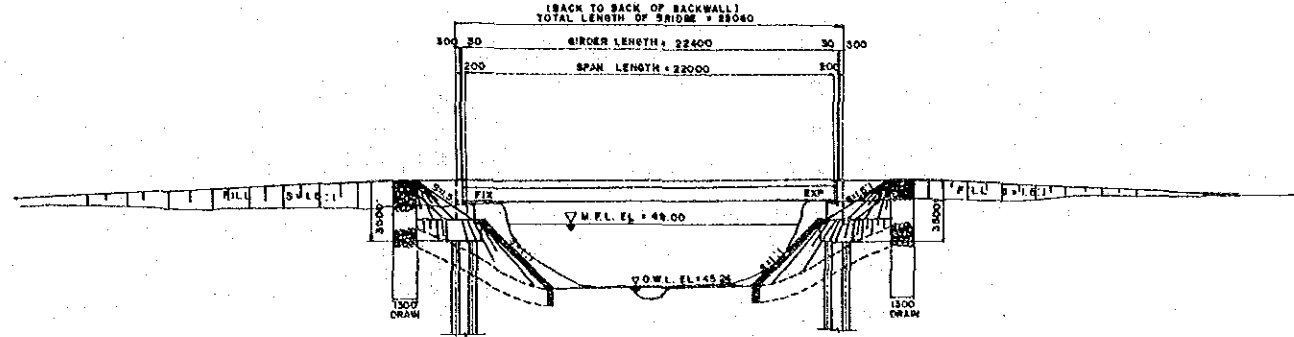

DL=40.00

GENERAL ELEVATION
SCALE 1:200

DL=40.00

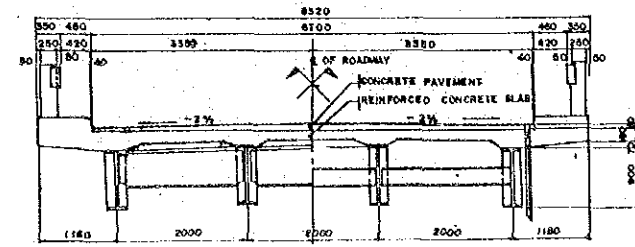

SUPERSTRUCTURE CROSS SECTION
SCALE 1:50

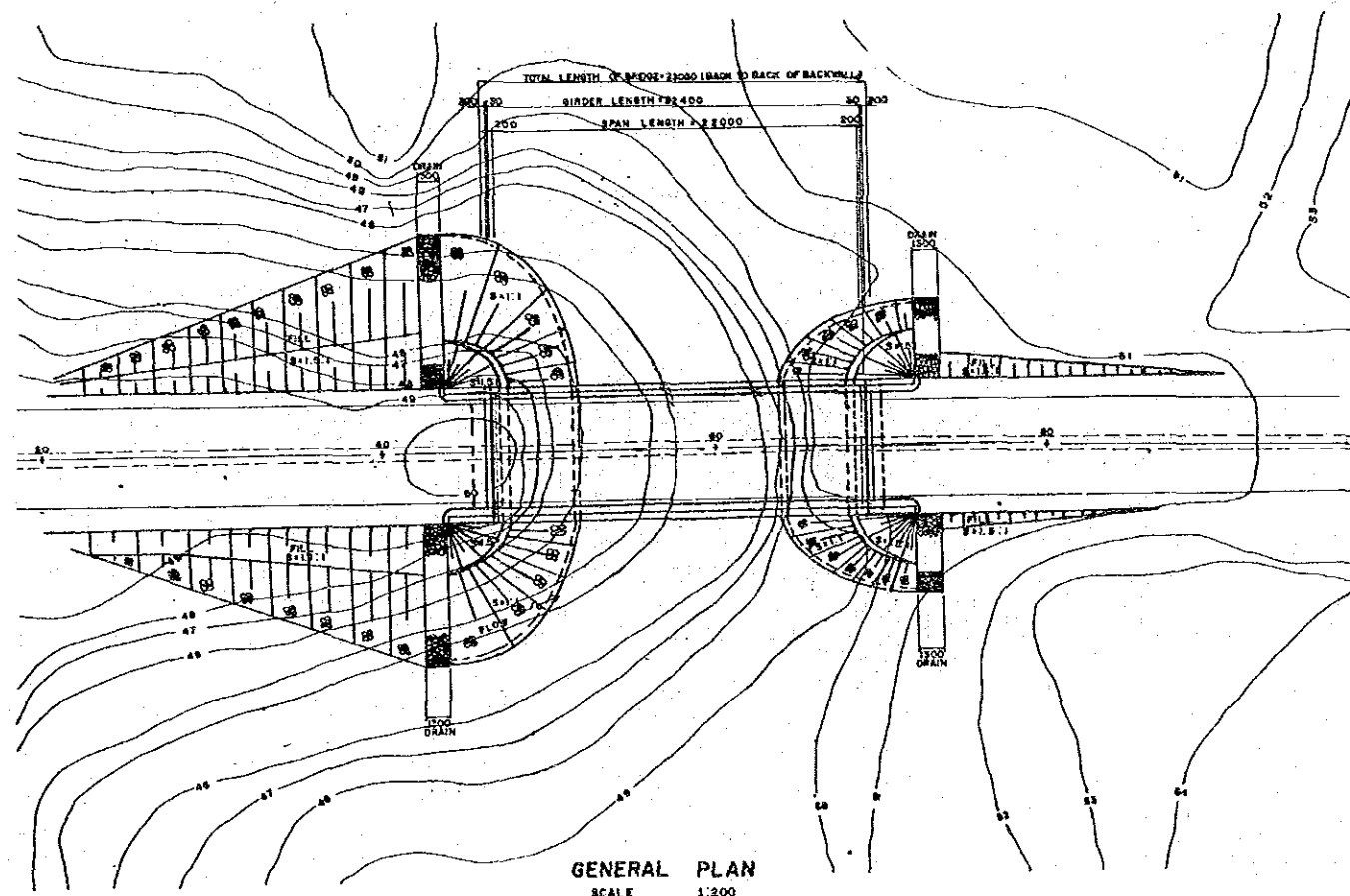

GENERAL PLAN
SCALE 1:200

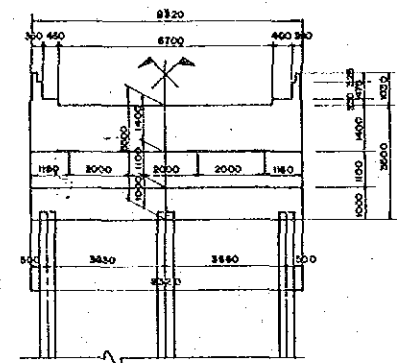

SUBSTRUCTURE CROSS SECTION
SCALE 1:100

GENERAL NOTES

1. Location of bridge should be determined by the Department of Public Works and Highways (DPWH).
2. Structural dimensions of superstructures should not be amended.
3. Types and dimensions of substructures shall be justified according to the detailed design of substructures prepared by DPWH.
4. Vertical clearance between the M.F.L. and the bottom of the girders of the superstructure shall be not less than 1.0 meter (Carrying no big debris).
5. DESIGN SPECIFICATION
AASHTO Standard Specifications for Highway Bridges (13th Edition 1985)
6. DESIGN LOAD

Dead Load:	Concrete	23.54 KN/m ³
	Fill Materials	17.63 KN/m ³
	Concrete Pavement	23.54 KN/m ³
Live Load:	Roadway Live Load	HS20-44 (MS-18)
	SideWalk Live Load	2.675 KN/m ²
- Temperature Change: Rise +10°, Fall -10°
- Earthquake Load: C=0.12 with Reference to Relevant AASHTO Provisions and Applicable Code.
- Other Loads: In accordance with 1985 AASHTO Specification
7. MATERIALS

Steel for Superstructure	Steel shall be Specified by JIS (Japanese Industrial Standard)
Concrete	Concrete for Superstructure f _c = 29.4 MPa Concrete for Substructure f _c = 20.7 MPa
Others:	Other Materials shall conform to ASTM

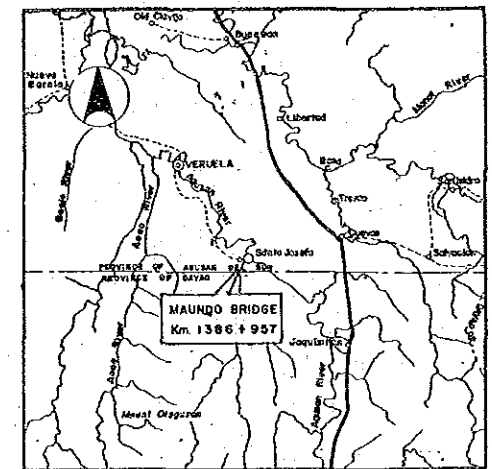

VICINITY MAP

DRAWINGS
All dimensions are expressed in millimeter unless otherwise shown in the plans.
All Elevations are in meters.

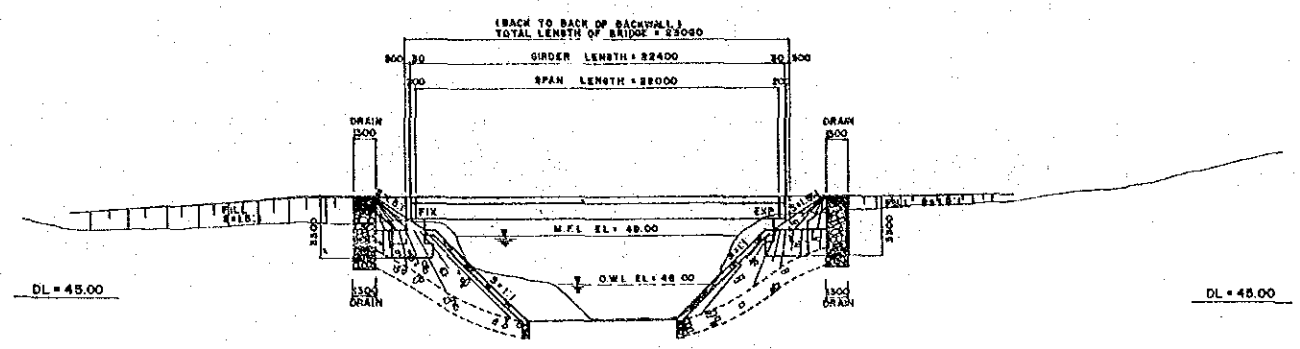

GENERAL ELEVATION
SCALE 1:200

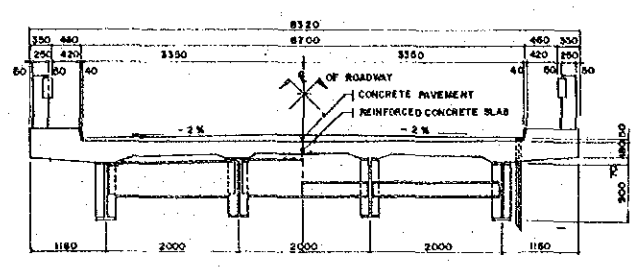

SUPERSTRUCTURE CROSS SECTION
SCALE: 1:50

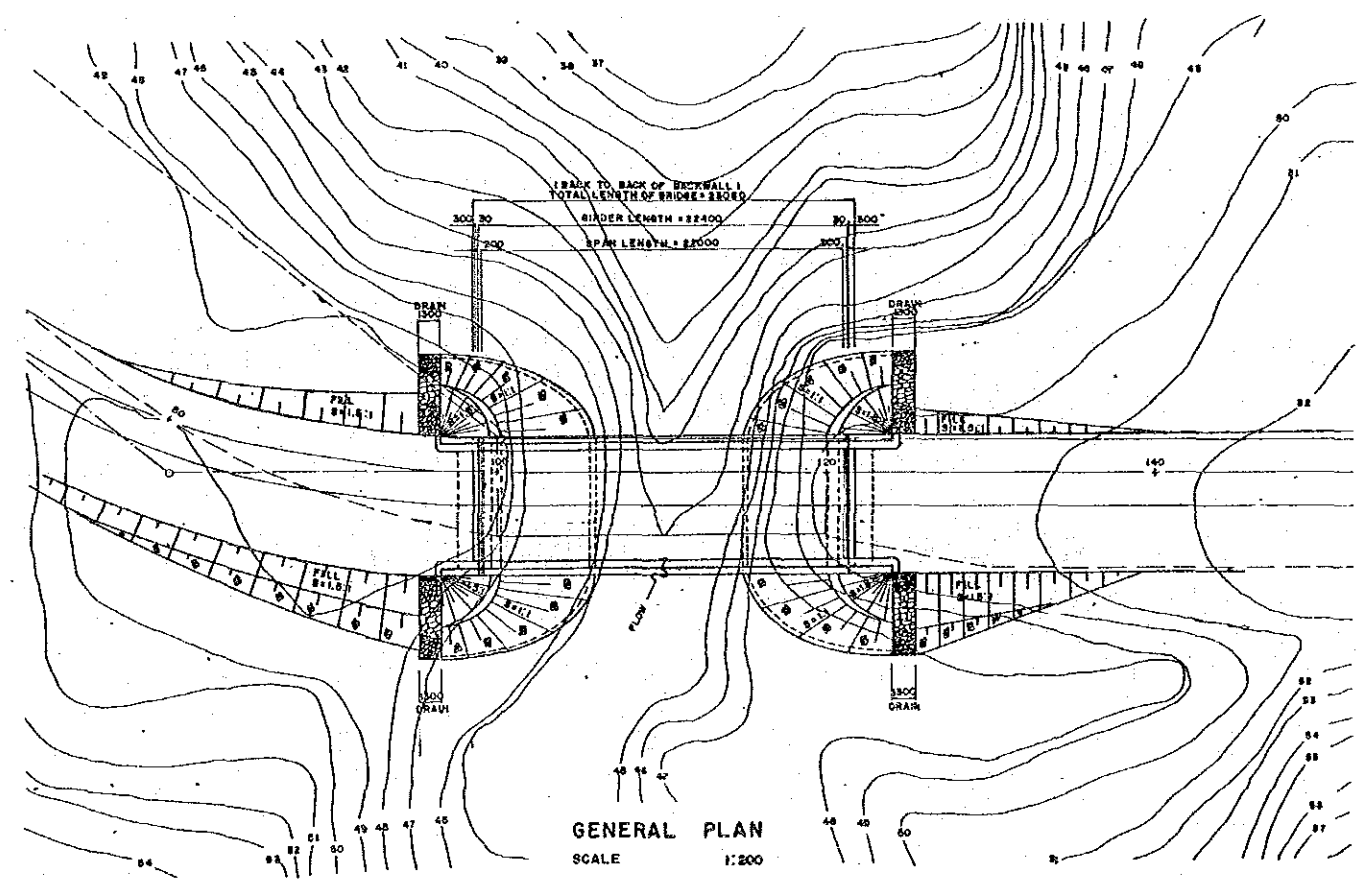

GENERAL PLAN
SCALE 1:200

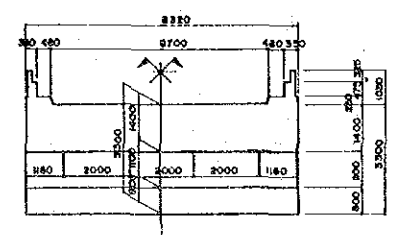

SUBSTRUCTURE CROSS SECTION
SCALE: 1:100

GENERAL NOTES

1. Location of bridge should be determined by the Department of Public Works and Highways (DPWH).
2. Structural dimensions of superstructures should not be amended.
3. Types and dimensions of substructures shall be justified according to the detailed design of substructures prepared by DPWH.
4. Vertical clearance between the M.F.L. and the bottom of the girders of the superstructure shall be not less than 4.0 meter (Carrying no big details).
5. DESIGN SPECIFICATION
AASHTO Standard Specifications for Highway Bridges (15th Edition 1993)
6. DESIGN LOAD

Dead Load:	Concrete	23.54 KN/m ³
	Fill Materials	17.65 KN/m ³
	Concrete Pavement	23.54 KN/m ³
Live Load:	Roadway Live Load	HSE0-44 (MS-10)
	Sidewalk Live Load	2.673 KN/m ²

Temperature Change:
Rise +10°, Fall -10°

Earthquake Load:
C = 0.12 with Reference to Relevant AASHTO Provisions and Applicable Code.

Other Loads: in accordance with 1993 AASHTO Specification.
7. MATERIALS

Steel for Superstructure:
Steel shall be Specified by JIS (Japanese Industrial Standard).

Concrete:
Concrete for Superstructure f_c = 29.4 MPa
Concrete for Substructure f_c = 20.7 MPa

Others:
Other Materials shall conform to ASTM

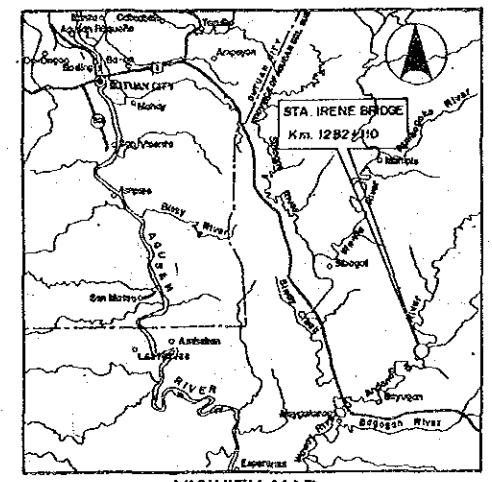

DRAWINGS
All Dimensions are expressed in millimeter unless otherwise shown in the plans.
All Elevations are in meters.

BASIC DESIGN STUDY ON THE PROJECT
FOR CONSTRUCTING BRIDGES ALONG RURAL ROADS (PHASE I)

BRIDGE NO. 10-05	MALUBOG BRIDGE Km. 185+760	SHEET NO. 24/31
---------------------	-------------------------------	--------------------

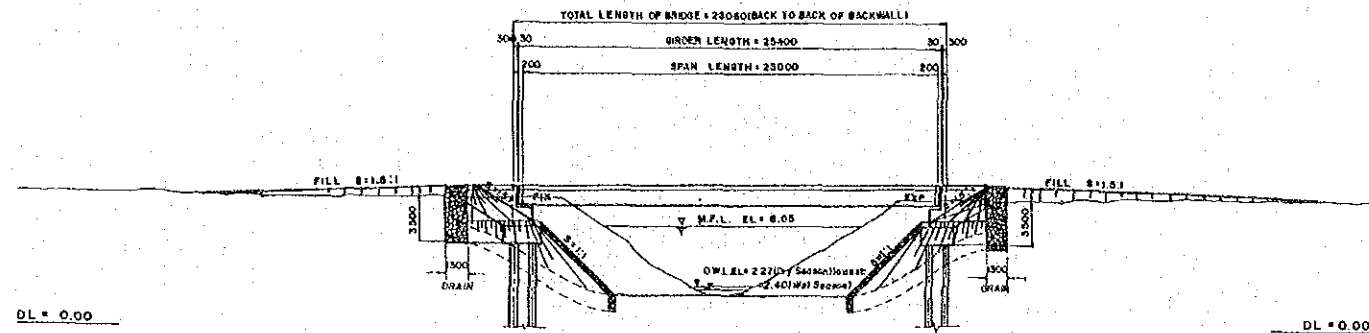

GENERAL ELEVATION
SCALE 1:200

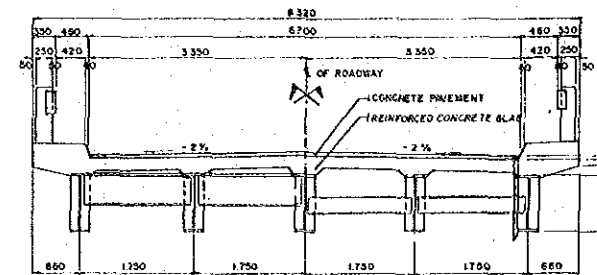

SUPERSTRUCTURE CROSS SECTION
SCALE 1:50

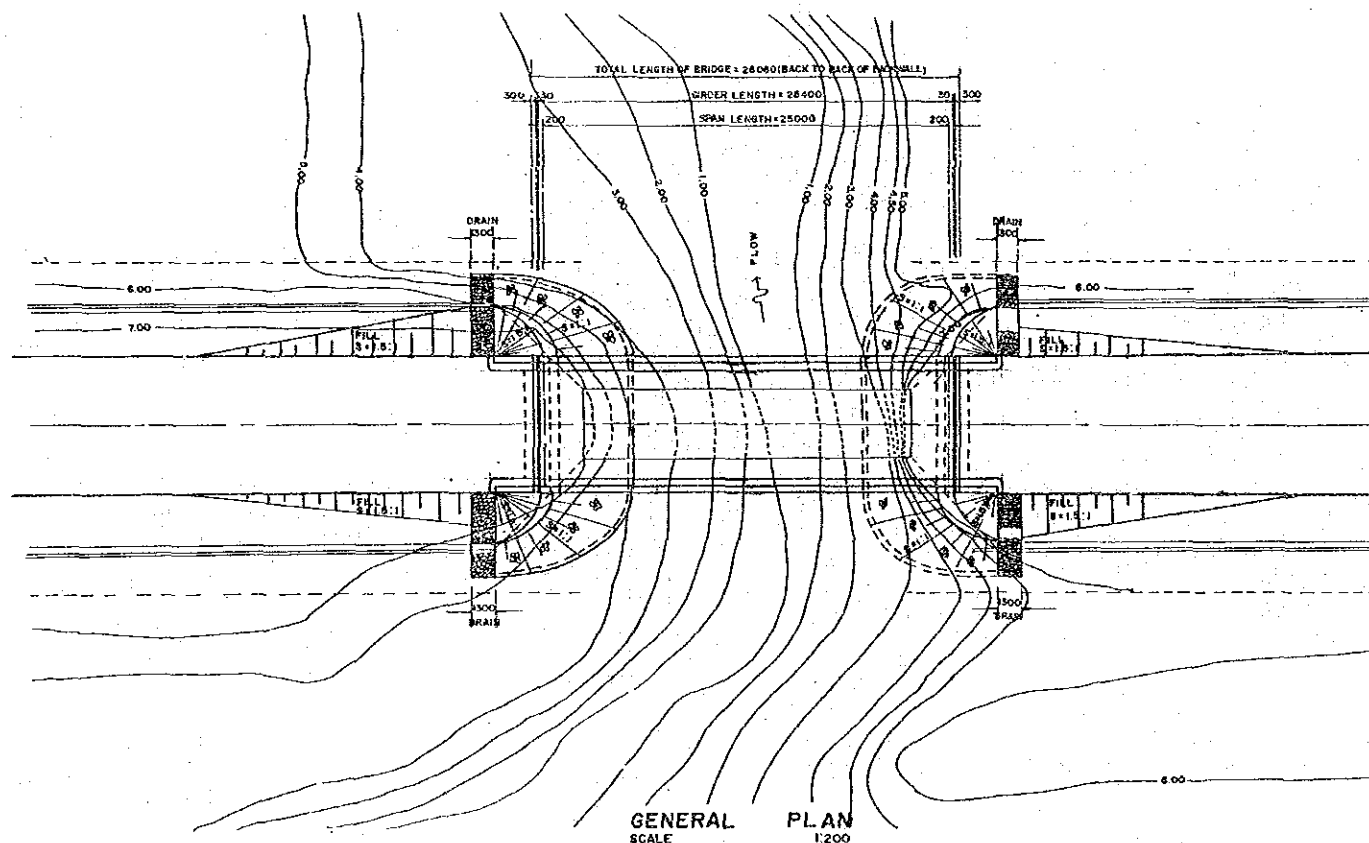

GENERAL PLAN
SCALE 1:200

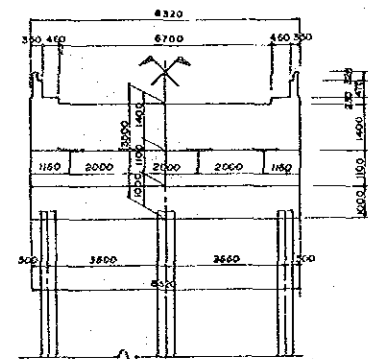

SUBSTRUCTURE CROSS SECTION
SCALE 1:100

GENERAL NOTES

- Location of bridge should be determined by the Department of Public Works and Highways (DPWH).
- Structural dimensions of superstructures should not be amended.
- Types and dimensions of substructures shall be justified according to the detailed design of substructures prepared by DPWH.
- Vertical clearance between the M.F.L. and the bottom of the girders of the superstructure shall be not less than 1.0 meter (Carrying no big debris).
- DESIGN SPECIFICATION
AASHTO Standard Specifications for Highway Bridges (13th Edition 1983)
- DESIGN LOAD:

Dead Load:	Concrete	23.54 KN/m ³
	Fill Materials	17.68 KN/m ³
	Concrete Pavement	25.04 KN/m ³
Live Load:	Roadway Live Load	HS 20-44 (MS-10)
	Sidewalk Live Load	2.873 KN/m ²

Temperature Change:
Rise +10°, Fall -10°
Earthquake Load:
C=0.12 with Reference to Relevant AASHTO Provisions and Applicable Code.
Other Loads: In accordance with 1983 AASHTO Specification
- MATERIALS

Steel for Superstructure:
Steel shall be Specified by JIS (Japanese Industrial Standard).

Concrete:
Concrete for Superstructure f_c'= 29.4 MPa
Concrete for Substructure f_c'= 20.7 MPa
Other Materials shall conform to ASTM

DRAWINGS
All Dimensions are express in millimeter unless otherwise shown in the plans.
All Elevations are in meters.

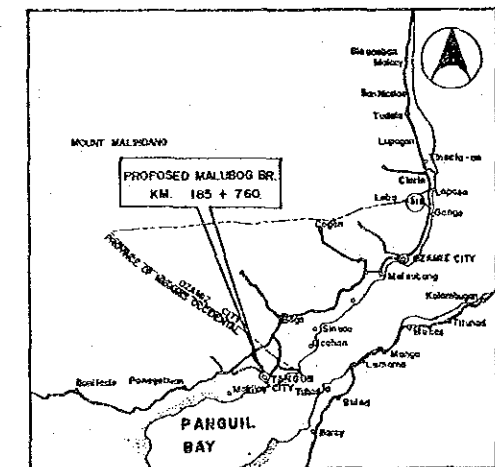

VICINITY MAP

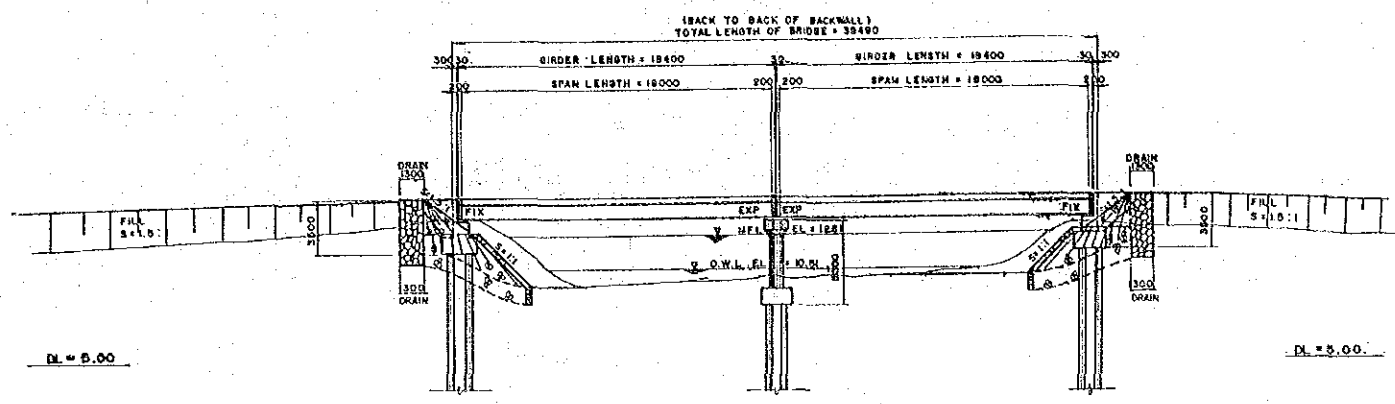

GENERAL ELEVATION
SCALE 1:200

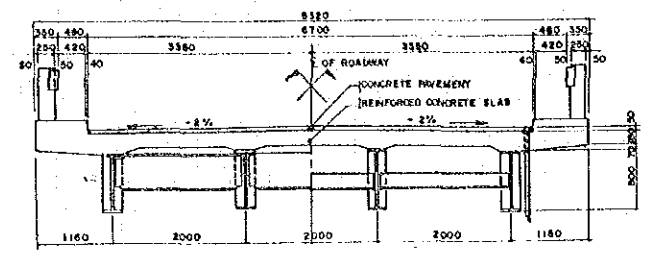

SUPERSTRUCTURE CROSS SECTION
SCALE 1:50

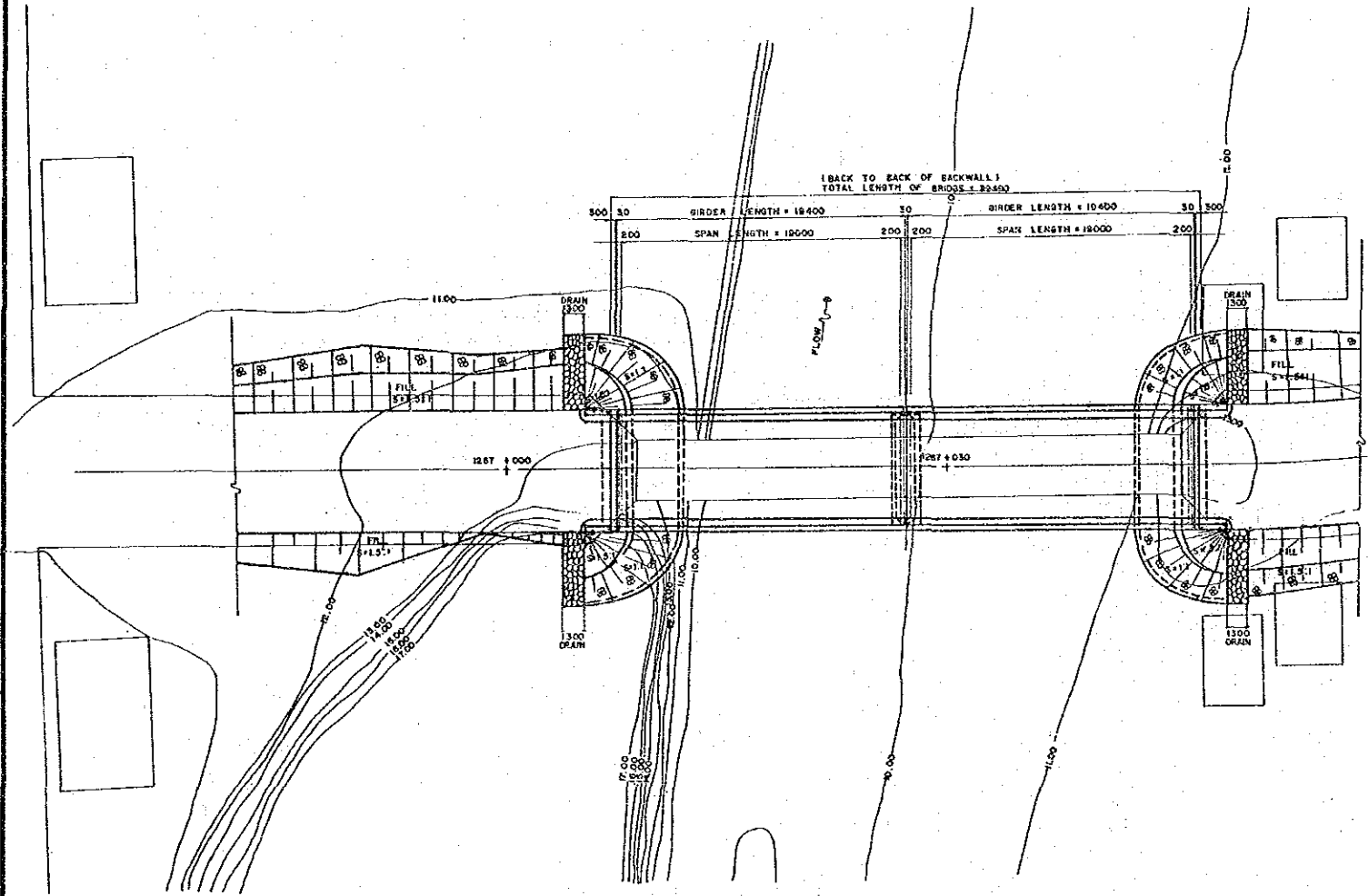

GENERAL PLAN
SCALE 1:200

DRAWINGS
All dimensions are expressed in millimeter unless otherwise shown in the plans.
All Elevations are in meters.

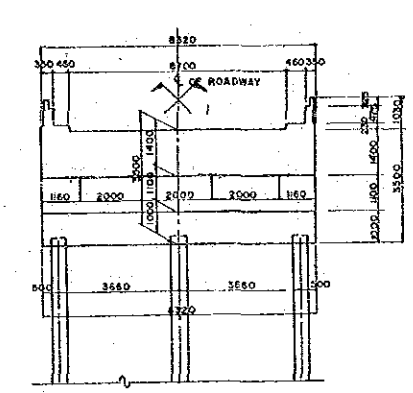

ABUTMENT

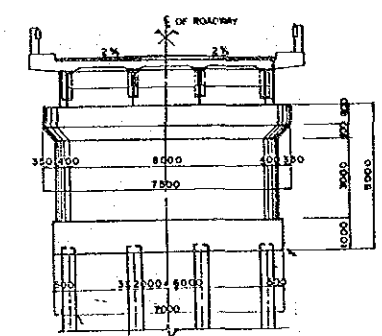

PIER

SUBSTRUCTURE CROSS SECTION
SCALE 1:100

GENERAL NOTES

1. Location of bridge should be determined by the Department of Public Works and Highways (DPWH).
2. Structural dimensions of superstructures should not be amended.
3. Types and dimensions of substructures shall be justified according to the detailed design of substructures prepared by DPWH.
4. Vertical clearance between the M.F.L. and the bottom of the girders of the superstructure shall be not less than 1.0 meter (Carrying no big debris).
5. DESIGN SPECIFICATION
AASHTO Standard Specifications for Highway Bridges (13th Edition 1985)
6. DESIGN LOAD

Dead Load: Concrete	23.54 KN/m ³
Fill Materials	17.56 KN/m ³
Concrete Pavement	23.54 KN/m ³
Live Load: Roadway Live Load	HS 20-44 (MS-18)
Sidewalk Live Load	2.873 KN/m ²

Temperature Change: Rise +10°, Fall -10°
 Earthquake Load: C = 0.12 with Reference to relevant AASHTO Provisions and Applicable Code
 Other Loads: In accordance with 1985 AASHTO Specification.
7. MATERIALS
 Steel for Superstructure: Steel shall be specified by JIS (Japanese Industrial Standard).
 Concrete: Concrete for Superstructure f_c' = 29.4 MPa
 Concrete for Substructure f_c' = 20.7 MPa
 Others: Other Materials shall conform to ASTM

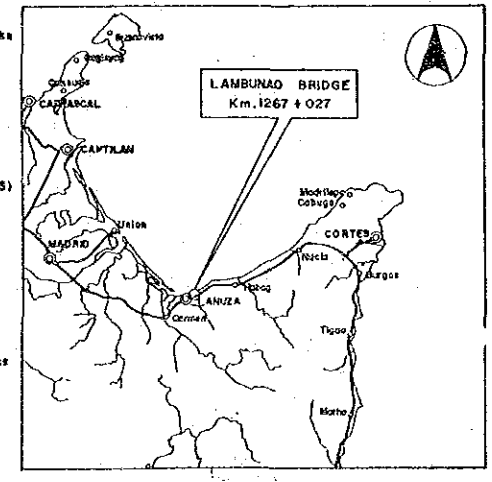

VICINITY MAP

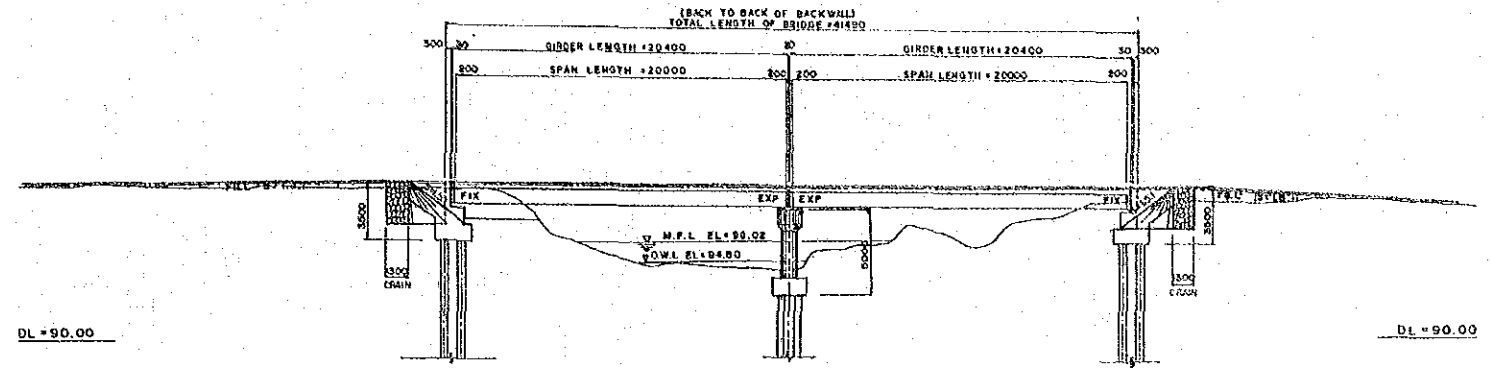

GENERAL ELEVATION
SCALE: 1:200

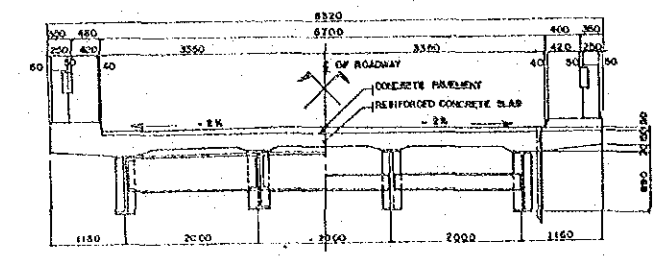

SUPERSTRUCTURE CROSS SECTION
SCALE: 1:50

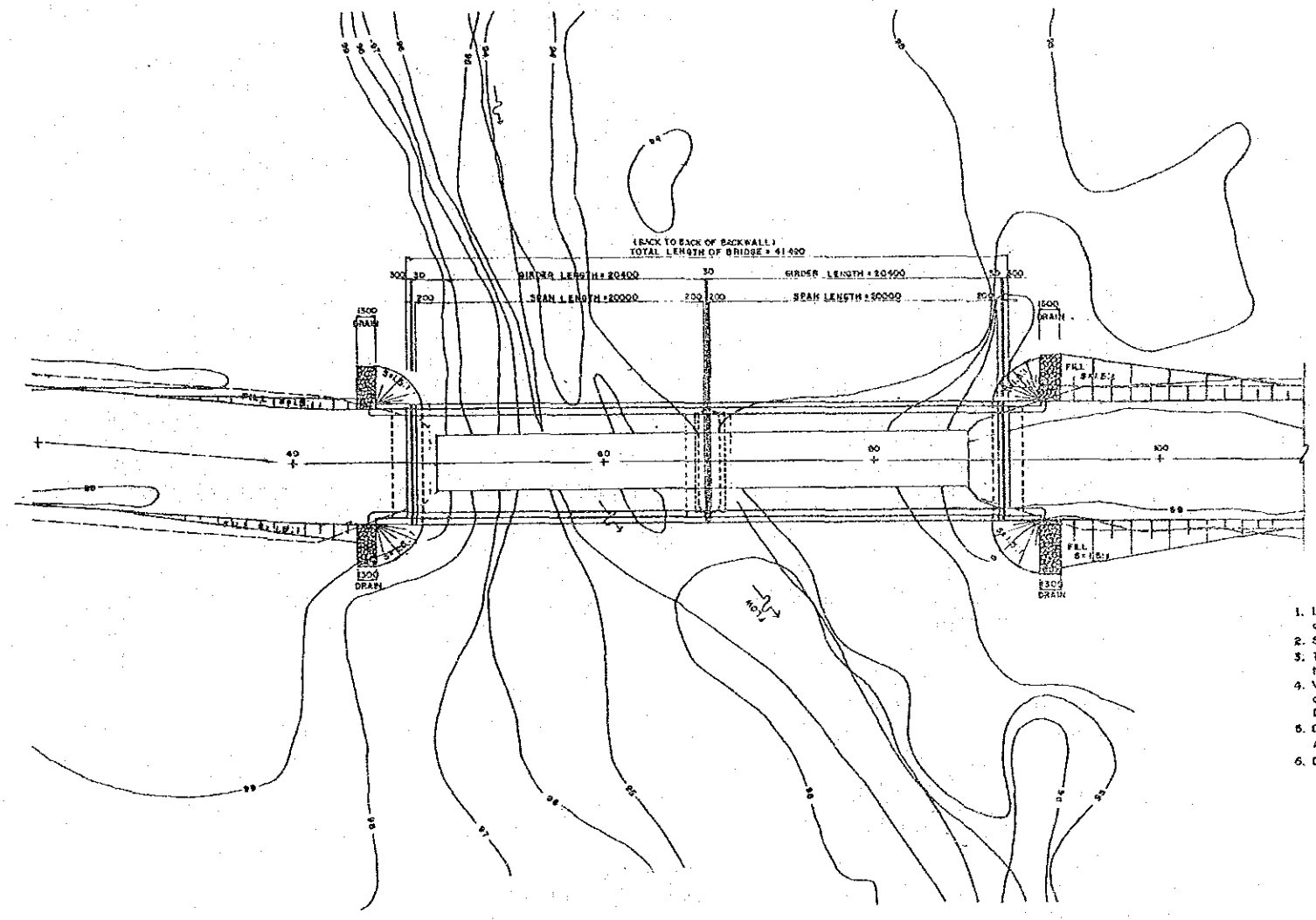

GENERAL PLAN
SCALE: 1:200

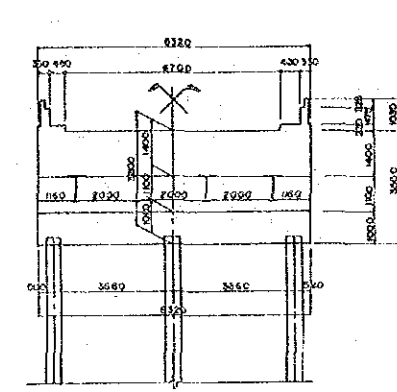

ABUTMENT

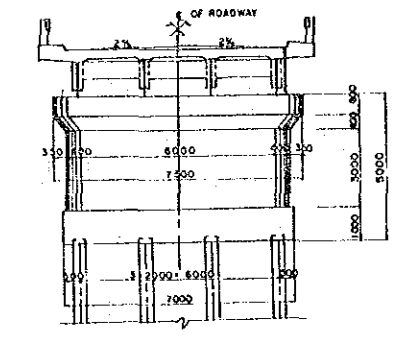

PIER

SUBSTRUCTURE CROSS SECTION
SCALE: 1:100

GENERAL NOTES

1. Location of bridge should be determined by the Department of Public Works and Highways (DPWH).
2. Structural dimensions of superstructures should not be amended.
3. Types and dimensions of substructures shall be justified according to the detailed design of substructures prepared by DPWH.
4. Vertical clearance between the M.F.L. and the bottom of the girders of the superstructure shall be not less than 1.0 meter (Carrying no big debris).
5. DESIGN SPECIFICATION
AASHTO Standard Specifications for Highway Bridges (13th Edition 1983)
6. DESIGN LOAD

Dead Load:	Concrete	23.54 KN/m ³
	FIN Materials	17.66 KN/m ³
	Concrete Pavement	23.84 KN/m ³
Live Load:	Roadway Live Load	HS 20-44 (MS-10)
	Skewalk Live Load	2.073 KN/m ²
Temperature Change:	Rise +10°, Fall -10°	
Earthquake Load:	C = 0.12 with Reference to Relevant AASHTO Provisions and Applicable Code.	
Other Loads:	In accordance with 1983 AASHTO Specification	
7. MATERIALS

Steel for Superstructure:	Steel shall be Specified by JIS (Japanese Industrial Standard).
Concrete:	Concrete for Superstructure f _c ' = 28.4 MPa Concrete for Substructure f _c ' = 20.7 MPa
Others:	Other Materials shall conform to ASTM

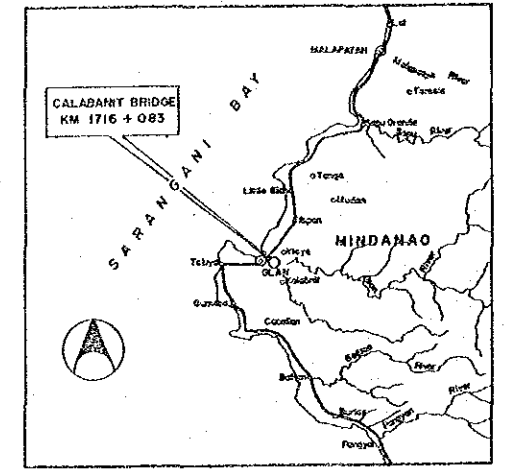

VICINITY MAP

DRAWINGS
All Dimensions are express in millimeter unless otherwise shown in the plans.
All Elevations are in meters.

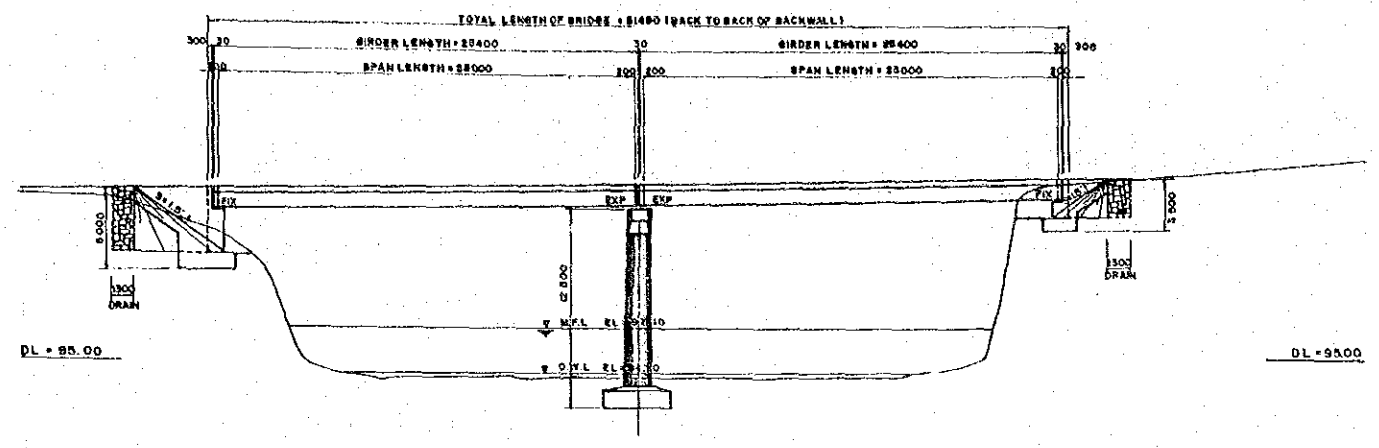

GENERAL ELEVATION
SCALE: 1:200

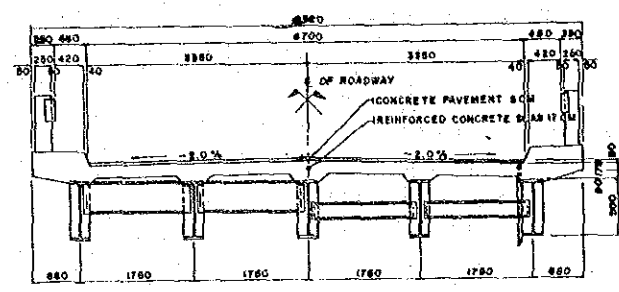

SUPERSTRUCTURE CROSS SECTION
SCALE: 1:50

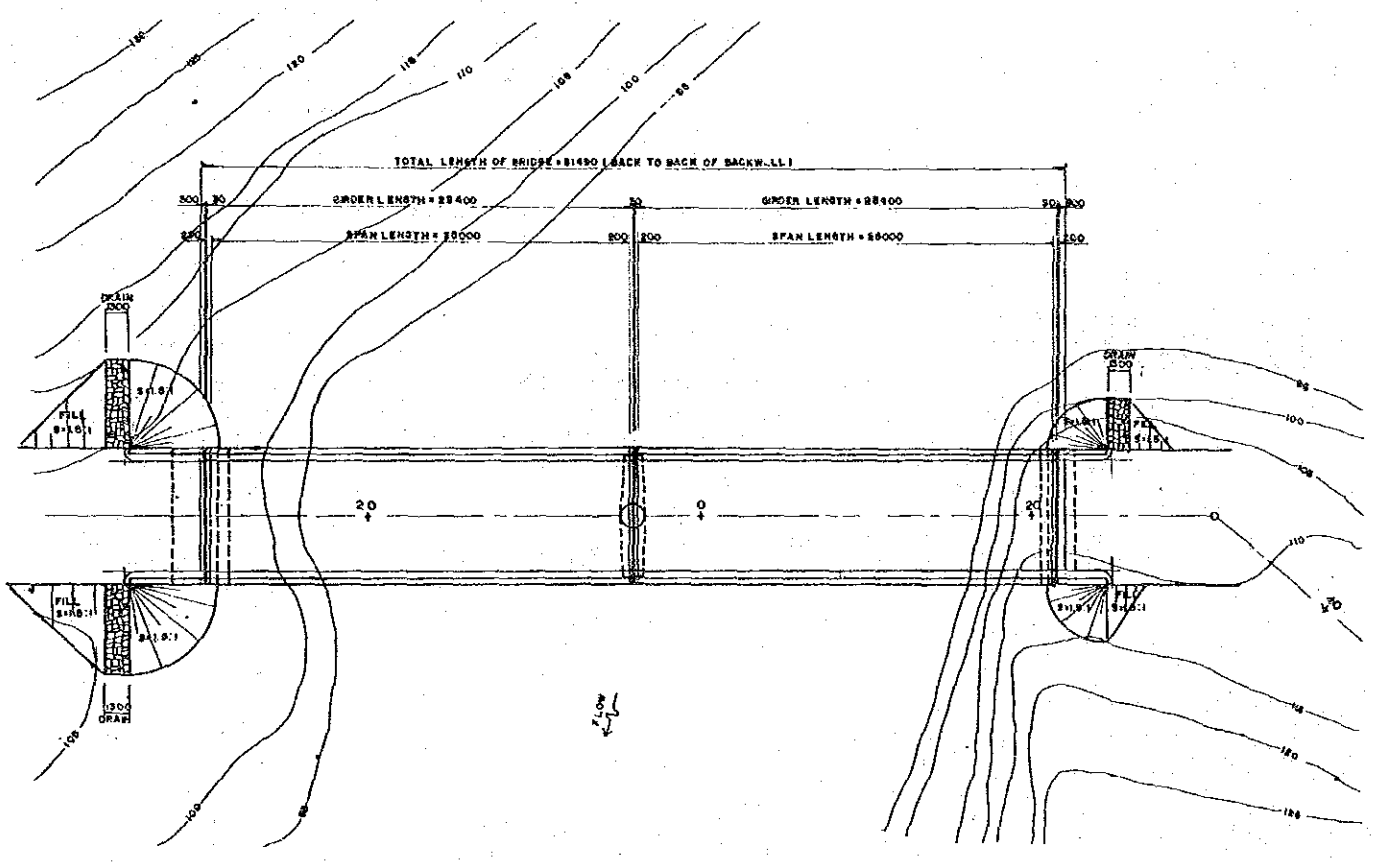

GENERAL PLAN
SCALE: 1:200

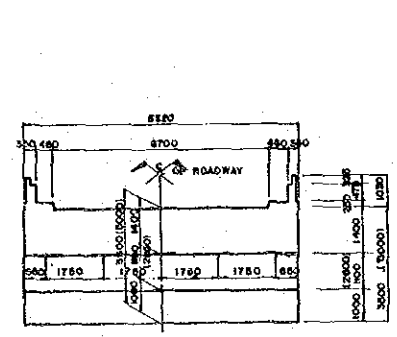

ABUTMENT

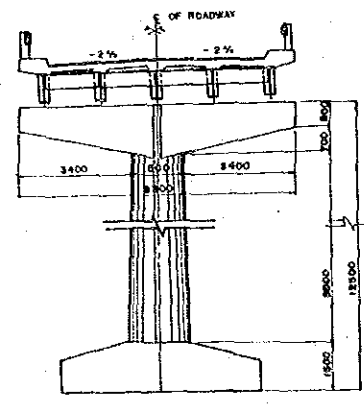

PIER

SUBSTRUCTURE CROSS SECTION
SCALE: 1:100

GENERAL NOTES

1. Location of bridge should be determined by the Department of Public Works and Highways (DPWH).
2. Structural dimensions of superstructures should not be amended.
3. Types and dimensions of substructures shall be justified according to the detailed design of substructures prepared by DPWH.
4. Vertical clearance between the N.F.L. and the bottom of the girders of the superstructure shall be not less than 1.0 meter (Carrying no big debris).
5. DESIGN SPECIFICATION
AASHTO Standard Specifications for Highway Bridges (18th Edition 1993)
6. DESIGN LOAD

Dead Load: Concrete	23.84 KN/m ³
Fill Materials	17.86 KN/m ³
Concrete Pavement	23.54 KN/m ³
Live Load: Roadway Live Load	HS20-44 (MS-18)
Sidewalk Live Load	2.973 KN/m ²
Temperature Change:	Rise +10° Fall -10°
Earthquake Load:	C=0.12 with Reference to Relevant AASHTO Provisions and Applicable Code.
Other Loads:	In accordance with 1988 AASHTO Specification.
7. MATERIALS

Steel for Superstructures:	Steel shall be Specified by AISI (American Industrial Standard).
Concrete:	Concrete for Superstructure f _c ' = 29.4 MPa
	Concrete for Substructure f _c ' = 20.7 MPa
Others:	Other Materials shall conform to ASTM

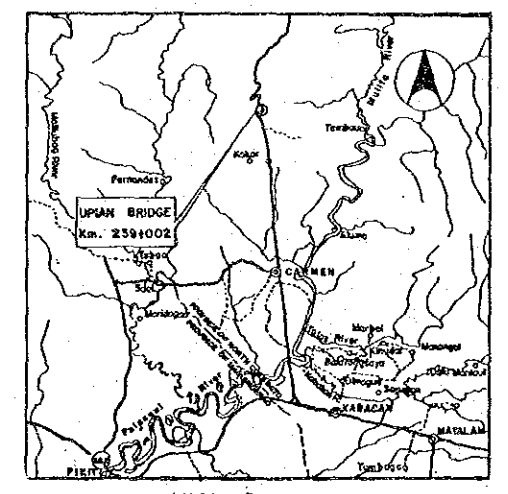

VICINITY MAP

DRAWINGS
All Dimensions are express in millimeter unless otherwise shown in the plans.
All Elevations are in meters

BASIC STRUCTURAL PLAN OF BRIDGES

BASIC DESIGN STUDY ON THE PROJECT
FOR CONSTRUCTING BRIDGES ALONG RURAL ROADS (PHASE I)

BRIDGE NO.	BASIC STRUCTURAL PLAN OF BRIDGES	SHEET NO.
ALL BRIDGES		28/31

GENERAL ELEVATION (SPAN L = 12m)
SCALE 1:100

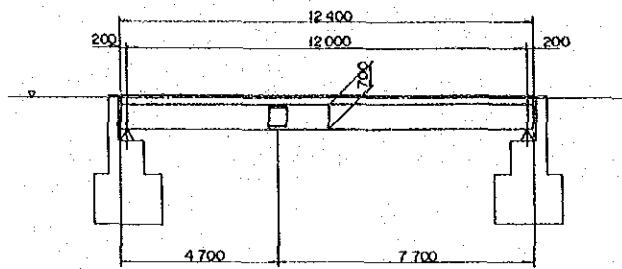

GENERAL PLAN (SPAN L = 12m)
SCALE 1:100

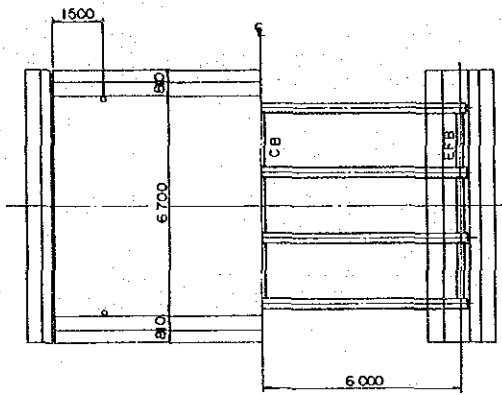

SUPERSTRUCTURE CROSS SECTION
SCALE 1:100

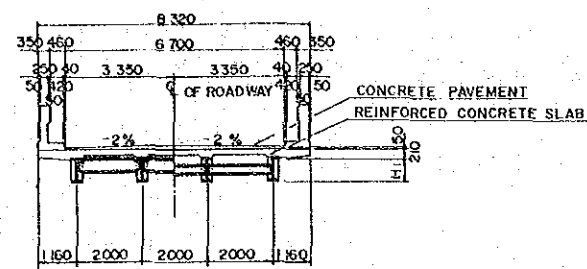

JOINT OF GIRDER (SMA 50)
SCALE 1:20

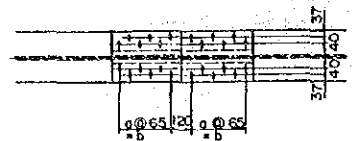

z-HTB, M22 x m (F10TW)

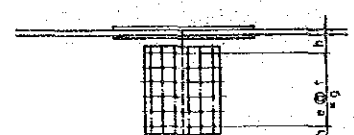

n-HTB, M22 x o (F10TW)

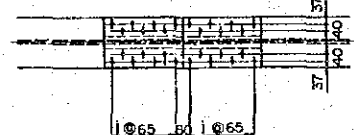

p-HTB, M22 x q (F10TW)

Quantity of Steel Member

Ordinary Steel		Weathering Steel	
Bridge No.	Name	Bridge No.	Name
02.03	Baan Bridge	02.04	Diora Bridge
06.04	Gultas Bridge	04.07b	Dipulas Bridge
08.05	Phuewanon Bridge	04.08b	Cogon Bridge
10.02	Maradugas Bridge	05.02	Pattinon Bridge
10.03	Maundo Bridge	06.02	Cataan Bridge
10.04	Sta. Irene Bridge	07.03	Camponga Bridge
12.03	Upion Bridge	07.04	Camachiles Bridge
		07.05	Lagnason Bridge
		08.01	Peray Bridge
		08.02	Iba Bridge
		09.01	Batungal Bridge
		09.02	Mangop Bridge
		09.03	Canawan Bridge
		09.04	Piangon Bridge
		10.05	Malubog Bridge
		11.01	Lambunao Bridge
		11.03	Calabanit Bridge

Dimension of Girder

GIRDER SIZE	a	b	c	d	e	f	g	h	j	k	l	m	n	o	p	q	r	s	t	u
H-700	5	325	2	150	5	90	450	125	6	390	24	90	36	75	28	95	10	12	12	16
H-792	5	325	2	150	6	90	540	126	5	325	24	85	42	75	24	90	10	12	12	16
H-800	6	390	2	150	6	90	540	130	6	390	28	90	42	75	28	100	10	14	14	19
H-890	5	325	3	225	8	80	640	125	6	390	24	85	72	75	28	95	10	12	12	16
H-900	6	390	3	225	8	80	640	130	7	455	28	95	72	75	32	105	12	14	14	22
H-912	8	520	3	225	8	80	640	136	9	585	36	115	72	80	40	120	14	19	19	25

GENERAL ELEVATION (SPAN L = 16.17.18.19.20.21.22.23m)
SCALE 1:100

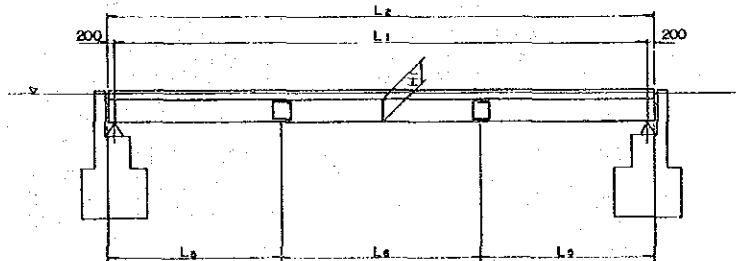

GENERAL PLAN (SPAN L = 16.17.18.19.20.21.22.23m)
SCALE 1:100

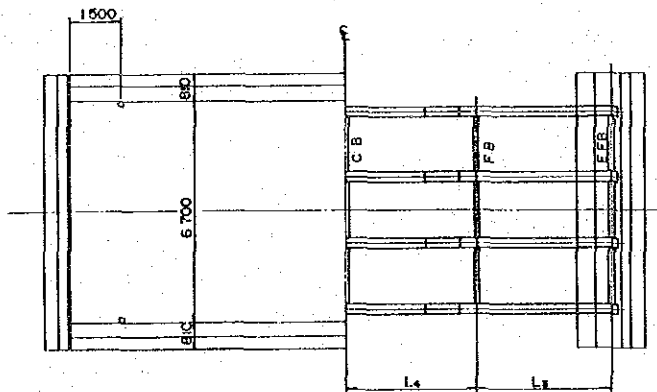

Cross Beam Spacing

SPAN (L ₁)	L ₂	L ₃	L ₄	L ₅	L ₆	H ₁
16 000	16 400	4 000	4 000	5 000	6 000	7 00
17 000	17 400	4 000	4 500	5 000	7 000	7 00
18 000	18 400	4 500	4 500	5 300	7 400	7 92
19 000	19 400	4 500	5 000	5 500	8 000	8 00
20 000	20 400	5 000	5 000	6 000	8 000	8 90
21 000	21 400	5 000	5 500	6 500	8 000	9 00
22 000	22 400	5 500	5 500	6 800	8 400	9 00
23 000	23 400	5 500	6 000	7 500	8 000	9 12

SECTION OF MAIN GIRDER (SMA 50)
SCALE 1:20

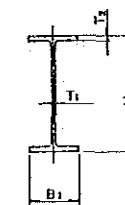

SPAN	H ₁	B ₁	T ₁	T ₂
12 m				
16 m	700	300	13	24
17 m				
18 m	792	300	14	22
19 m	800	300	14	26
20 m	890	299	15	23
21 m	900	300	16	28
22 m				
23 m	912	302	18	34

BRIDGE NO.		SHEET NO.
ALL BRIDGES	DETAILS OF MAIN GIRDERS	29/31

DETAILS OF MAIN GIRDER SCALE 1:30

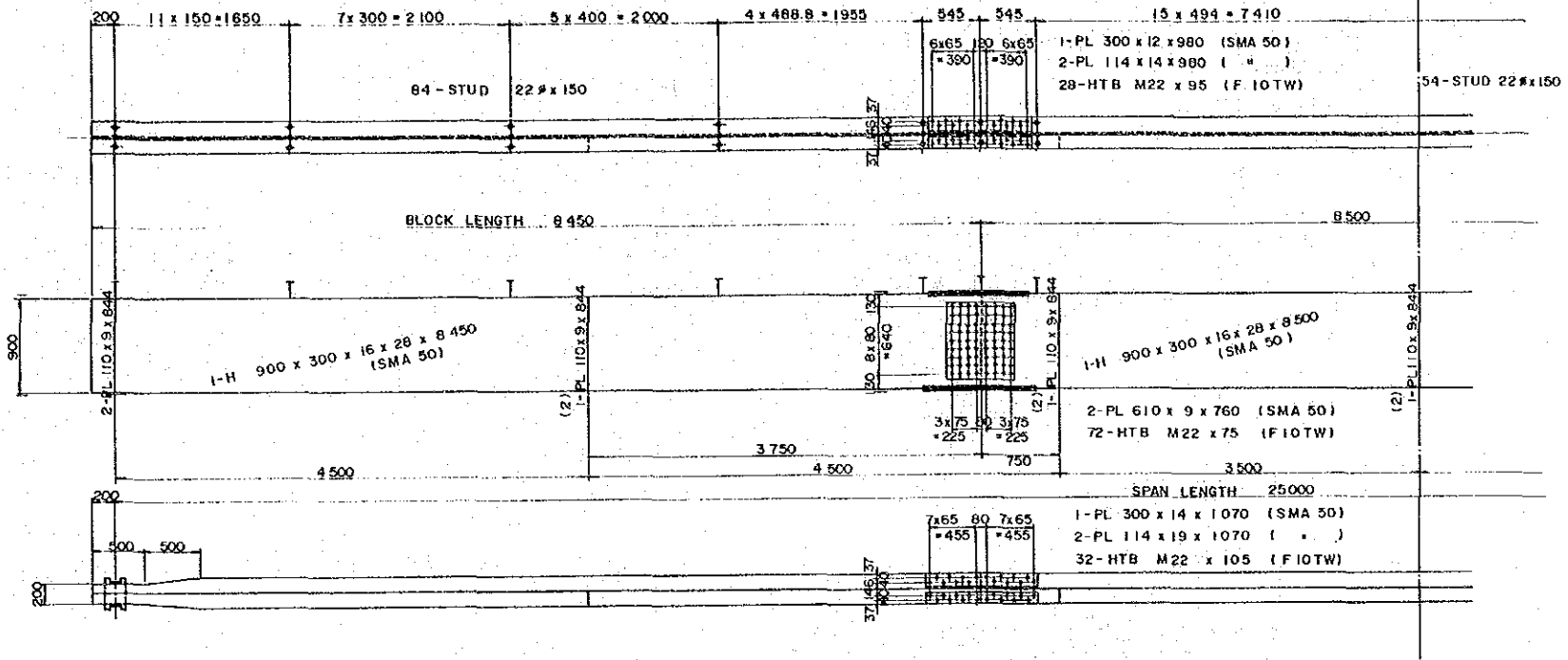

DETAIL OF STUD SCALE 1:10

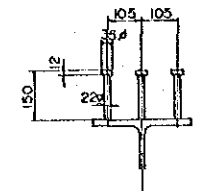

DETAIL OF SOLEPLATE SCALE 1:10

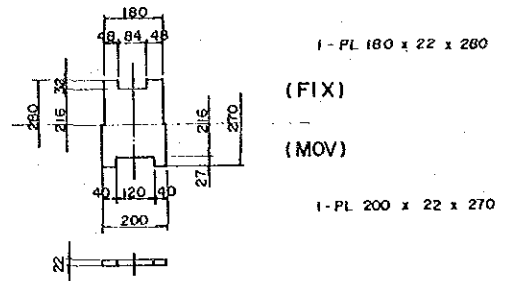

CROSS BEAM SCALE 1:30

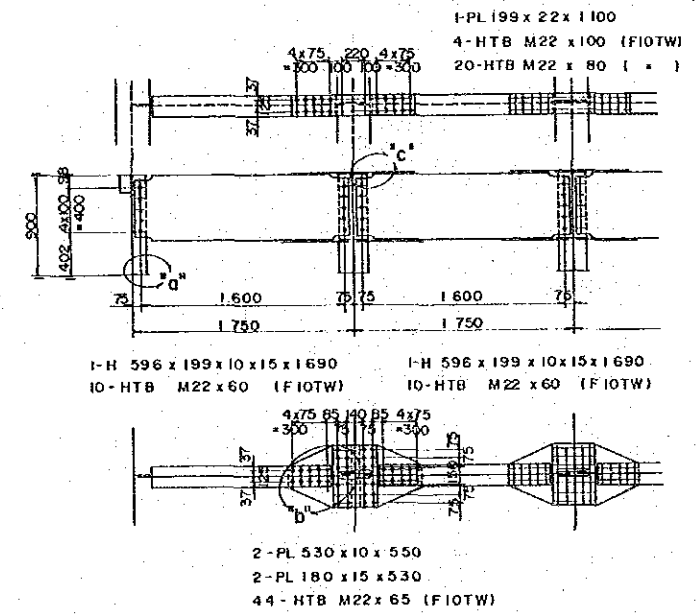

END FLOOR BEAM SCALE 1:30

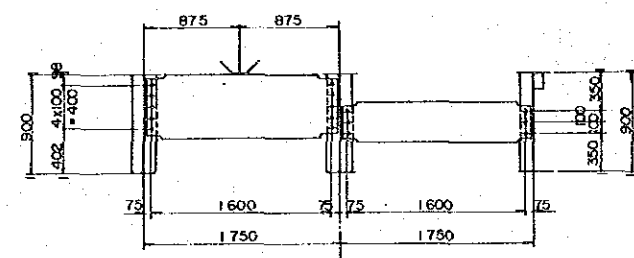

FLOOR BEAM SCALE 1:30

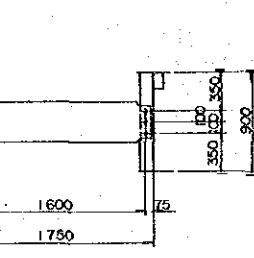

MARKING DIAGRAM

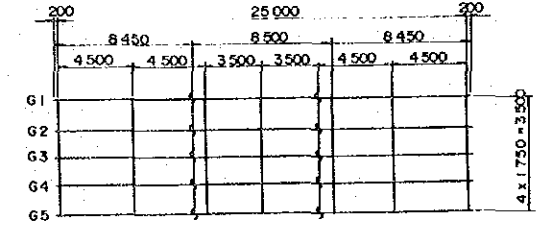

DETAIL OF SLAB ANCHER SCALE 1:10

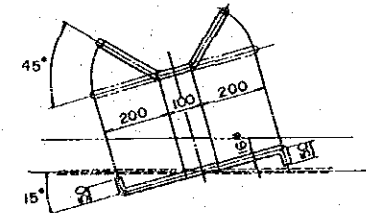

DETAIL OF "a"

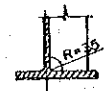

DETAIL OF "b"

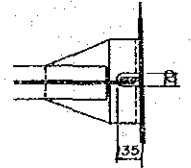

DETAIL OF "c"

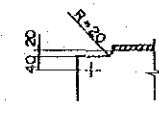

NOTE
1. MATERIAL STANDARD NOT DESCRIBED
HEREIN IS JIS G3114 SMA 41

DETAILS OF CROSS BEAMS

BASIC DESIGN STUDY ON THE PROJECT FOR CONSTRUCTING BRIDGES ALONG RURAL ROADS (PHASE I)		
BRIDGE NO.	DETAILS OF CROSS BEAMS	SHEET NO.
ALL BRIDGES		30/31

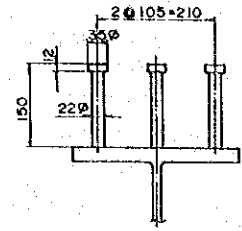

STUD BOLT ARRANGEMENT

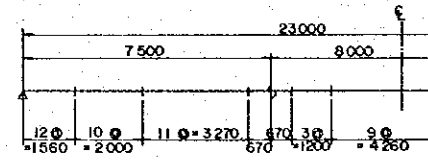
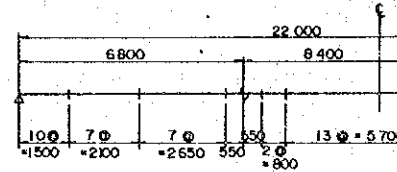
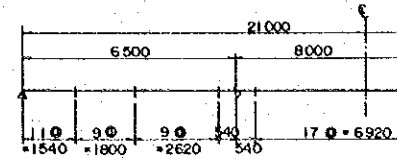
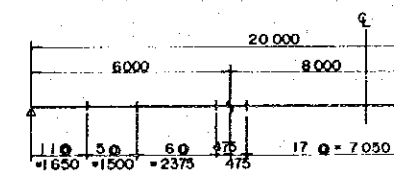
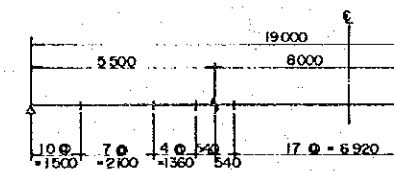
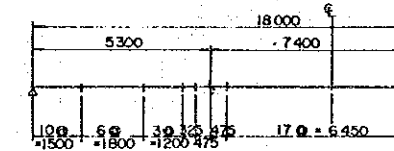
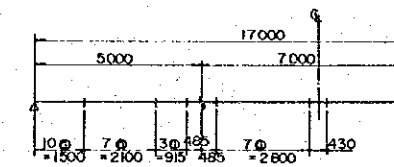
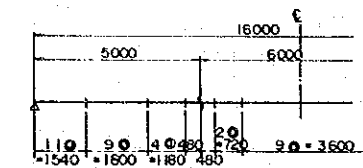
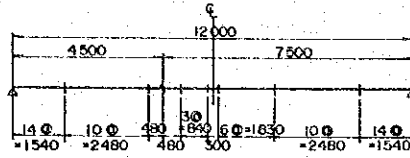

DETAIL OF SOLE PLATE (SMA41)
SCALE 1:10

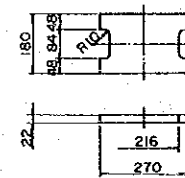

FIX TYPE

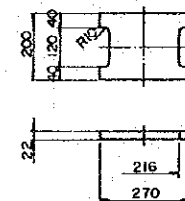

MOVE TYPE

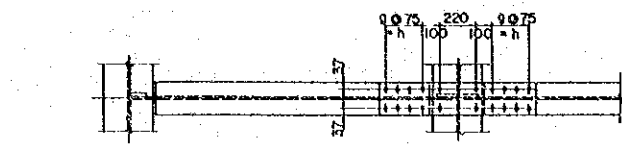

16 - HTB. M22 x 1 (FIOTW)
(12)
4 - HTB. M22 x 1 ()
1 - R. 200 (199) x k x f (SMA 41)

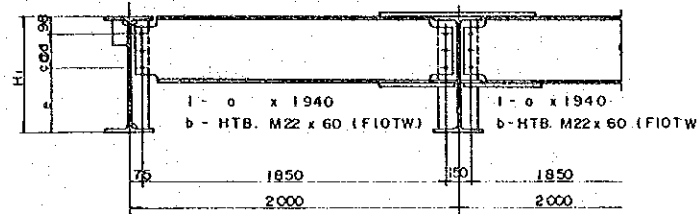

DETAIL OF CROSS BEAM
SCALE 1:20

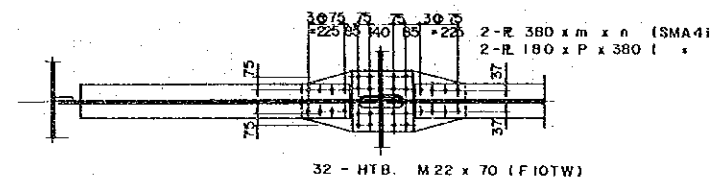

32 - HTB. M22 x 70 (FIOTW)

DETAIL OF END FLOOR BEAM
SCALE 1:20

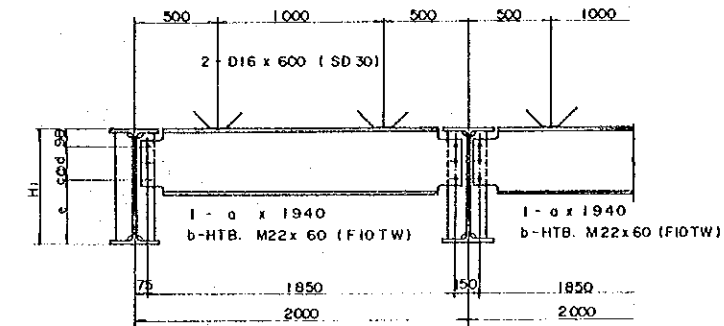

DETAIL OF FLOOR BEAM
SCALE 1:20

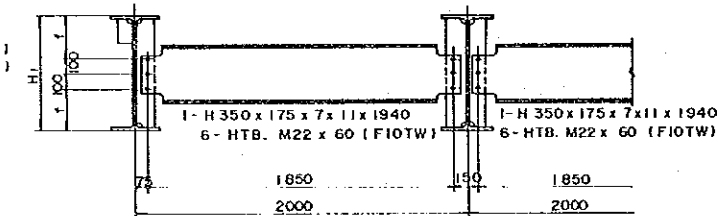

SPAN	a	b	c	d	e	f	g	h	i	j	k	l	m	n	p	q	H
12 m					402	250											700
16 m	H - 400 x 200 x 8 x 13	3	3	80	402	250	2	150	70	80	14	800	9	400	13	65	700
17 m					402	250											700
18 m					294	296											792
19 m					302	300											800
20 m	H - 596 x 199 x 10 x 15	5	4	100	392	345	3	225	75	95	19	950	14	475	15	70	890
21 m					402	350											900
22 m					402	350											900
23 m					414	356											912

DETAIL OF STIFFNER
SCALE 1:20

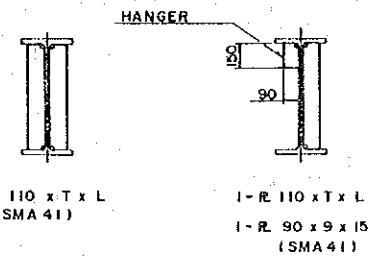

GIRDER SIZE	NO FLOOR BEAM		
	T	T	L
H - 700	9	9	652
H - 792	9	9	748
H - 800	9	9	748
H - 890	9	9	844
H - 900	12	9	844
H - 912	12	9	844

DRAIN

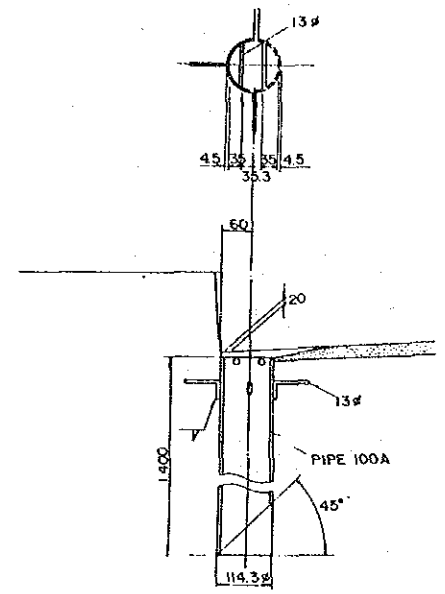

GUARD RAIL

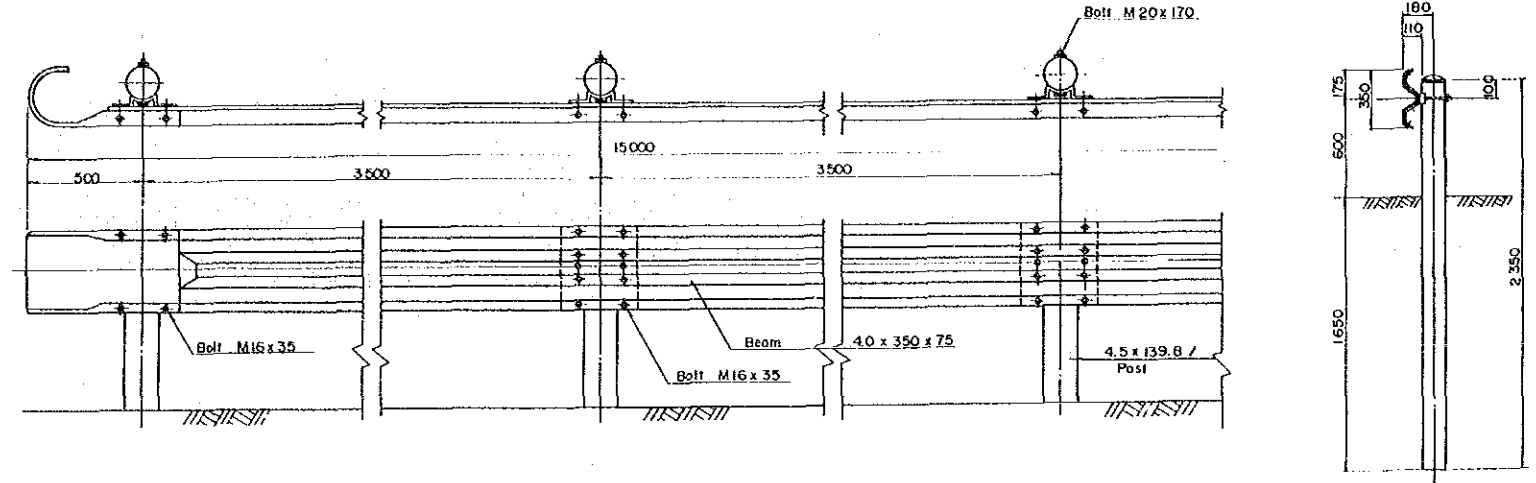

SHOES

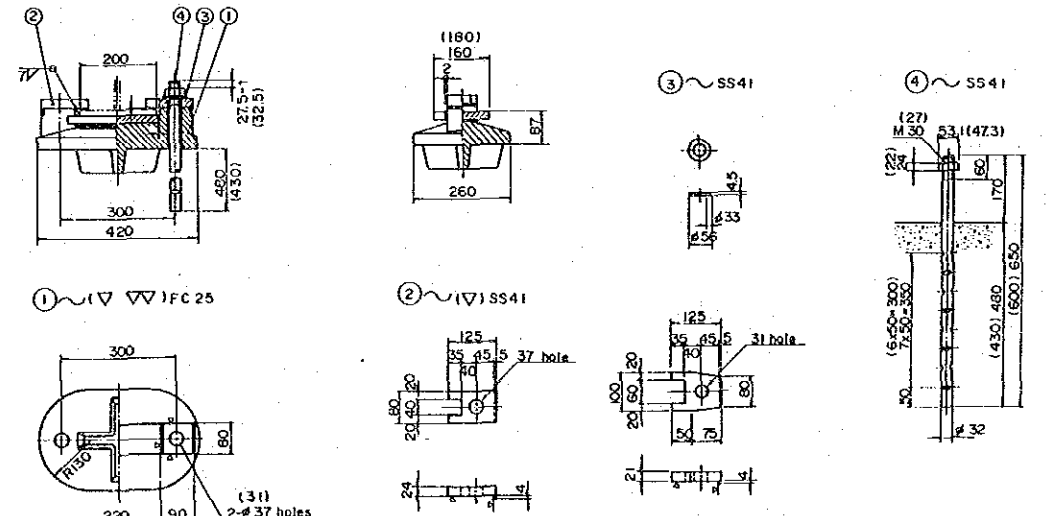

FIX

(MOV)

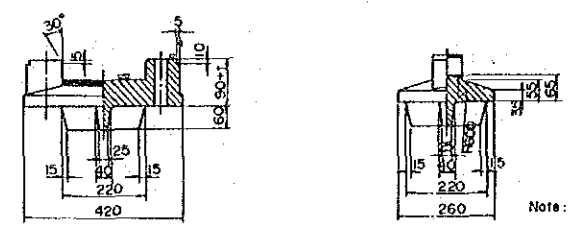

L	t
12 ~ 17	24
18	22
19	26
20	23
21, 22, 25	28
23	34

Note: Dimensions of movable bearing are shown in ().

MARKING

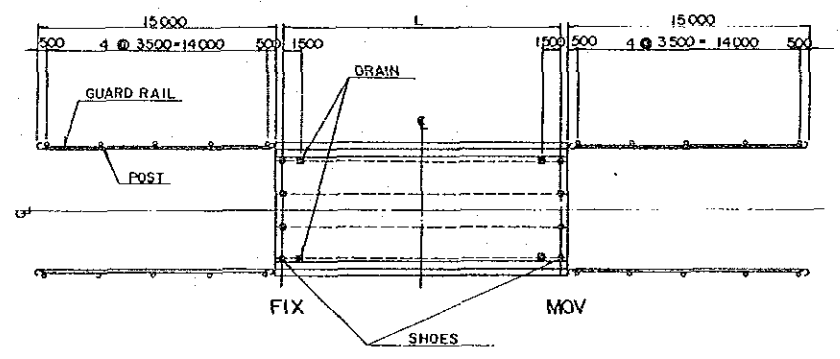

JICA