

REPUBLIC OF PARAGUAY

**CONSTRUCTION PROJECT
OF
MICROWAVE NETWORK**

Vol. III

PART IV ANNEX

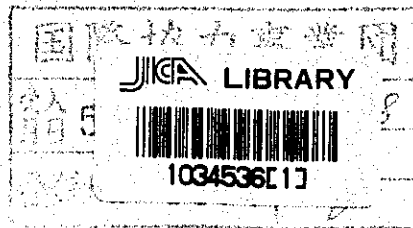

This report is one of the following three volumes:

- Volume I Planning Report
- Volume II Detailed Design
- Volume III Tender Document and
Technical Specification
 - Part I General Instructions for Tender
 - Part II Contractual Terms and Conditions
 - Part III Technical Specifications for Supply
and Installations of Communication
Equipment
 - Part IV Annex

国際協力事業団

受入 月日 '84. 9. 20	708
登録No. 08214	64.7
	KE

LIST OF FIGURES

Fig. 1-1	Map of Microwave Route	1
Fig. 1-2	Microwave System Configuration	2
	Abbreviation for Fig. 1-2	2
Fig. 2-1	Path Profile (Asuncion-Paraguari)	3
Fig. 2-2	Path Profile (Paraguari-Valle Apua)	4
Fig. 2-3	Path Profile (Valle Apua-Caapucu)	4
Fig. 2-4	Path Profile (Caapucu-S.J. Bautista)	5
Fig. 2-5	Path Profile (S.J. Bautista-Estero Camba)	6
Fig. 2-6	Path Profile (Estero Camba-Pilar)	7
Fig. 2-7	Path Profile (Pilar-Paso de Patria)	8
Fig. 2-8	Path Profile (Paraguari-Cnel. Oviedo)	9
Fig. 2-9	Path Profile (Cnel. Oviedo-Caaguazu)	10
Fig. 2-10	Path Profile (Caaguazu-Guyraungua)	11
Fig. 2-11	Path Profile (Guyraungua-Colonia Yguazu)	12
Fig. 2-12	Path Profile (Colonia Yguazu-Stroessner)	13
Fig. 2-13	Schematic Diagram of Terminal Station (Asuncion)	14
Fig. 2-14	Schematic Diagram of Terminal Station (Paraguari)	15
Fig. 2-15	Schematic Diagram of Terminal Station	16
	(Cnel. Oviedo, S. Juan Bautista)	17
Fig. 2-16	Schematic Diagram of Terminal Station (Pto. Pte. Stroessner)	17
Fig. 2-17	Schematic Diagram of Terminal Station (Pilar)	18
Fig. 2-18	Schematic Diagram of Repeater Station (Paso de Patria)	18
Fig. 2-19	Schematic Diagram of Repeater Station (Except Paso de Patria)	19
Fig. 2-20	Abbreviation	19
Fig. 2-21	Supervisory and Control System	20
Fig. 3-1	Channel Layout	21
Fig. 3-2	Channel Layout	22
Fig. 3-3	Typical Carrier Multiplex System Block Diagram	23

Fig. 6-1	Power Supply System-I (Commerical Power is Available)	25
Fig. 6-2	Power Supply System-II (Commercial Power is Unavailable)	...	25
Fig. 6-3	Power Supply System-III (Commercial Power is Unavailable)	...	26
Fig. 9-1	Conceptional Figure of the Tower with Antenna	28
Fig. 9-2	Conceptional Figure of the Tower with Antenna	28

LIST OF TABLES

Table 3-1	Number of Circuits	23
Table 4-1	Toll Cable System	24
Table 7-1	Measuring Equipment	27

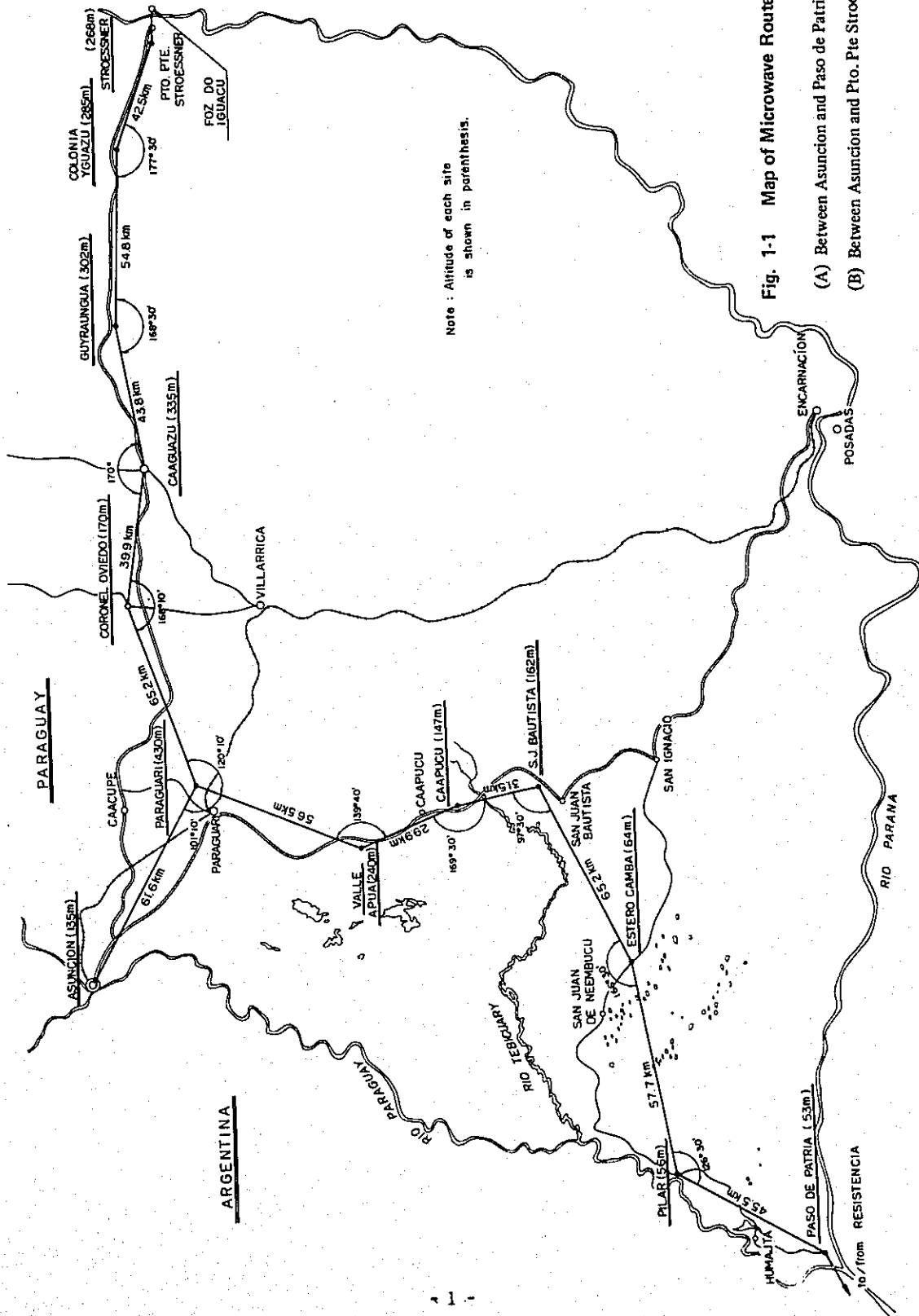

Fig. 1-1 Map of Microwave Route

(A) Between Asuncion and Paso de Patria

(B) Between Asuncion and Pto. Pte Stroessner

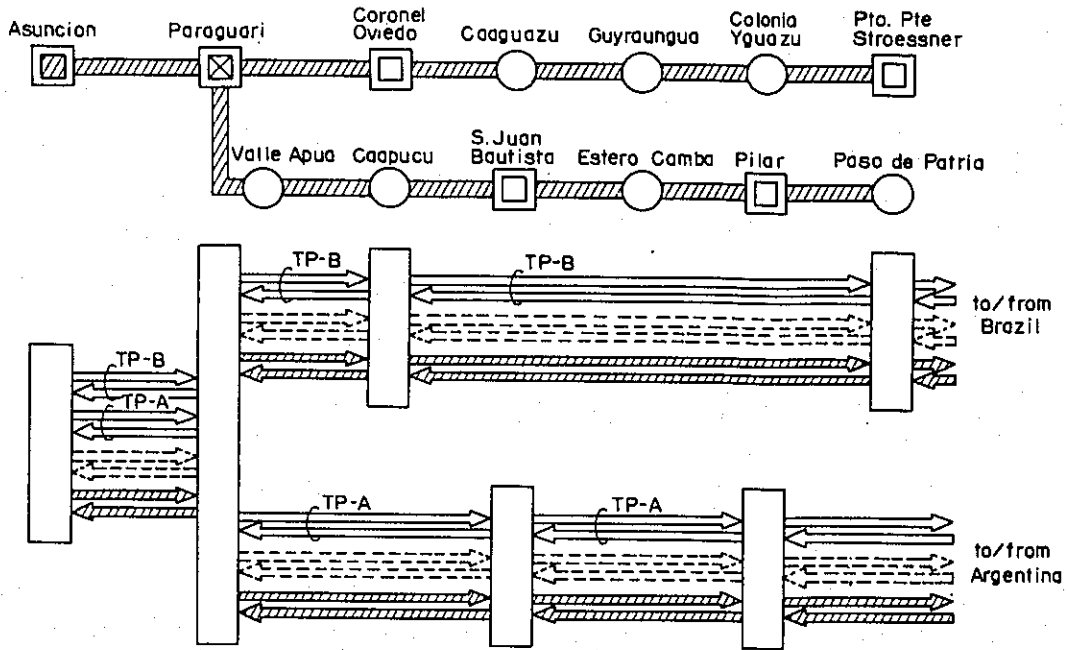









Fig. 1-2 Microwave System Configuration

-  Terminal Station
-  Back-to-Back Terminal Station
-  Back-to-Back Terminal Station With A Branching Radio Route
-  Through Repeater Station
-  TP 960CH Transmission System
TP-A and TP-B mean the telephone transmission systems between Asuncion and Argentina, between Asuncion and Brazil, respectively.
-  TV Transmission System (Future)
-  Stand-by System

Abbreviation for Fig. 1-2

Fig. 2-1 PATH PROFILE

(K=4/3)

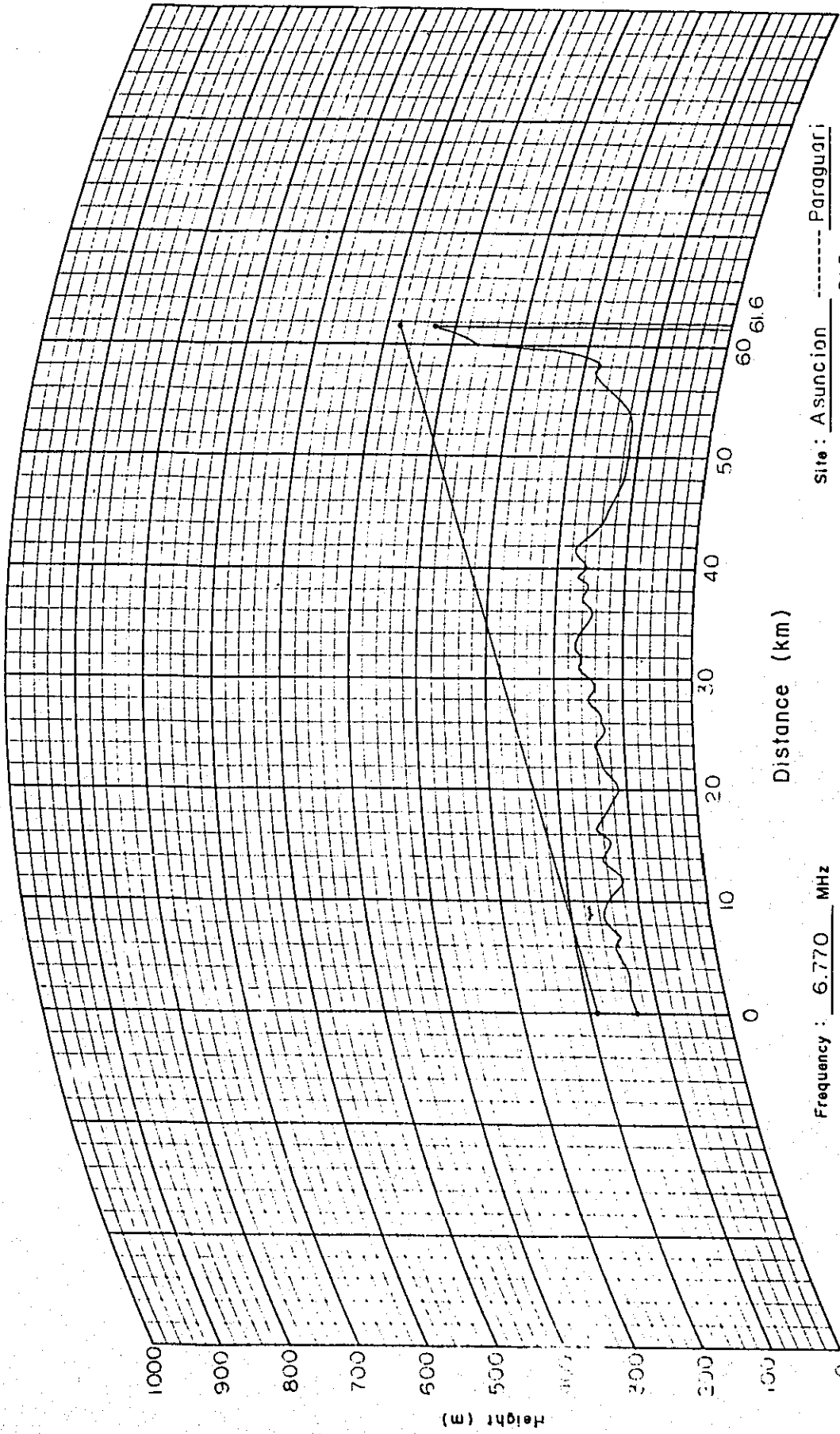

Frequency : 6.770 MHz

Site : Asuncion ----- Paraguari

Full Scale 120 km

Height : 135 m 61.6 km 430 m

Antenna Height : 55 m 50 m

Fig. 2-2 PATH PROFILE

(K=4/3)

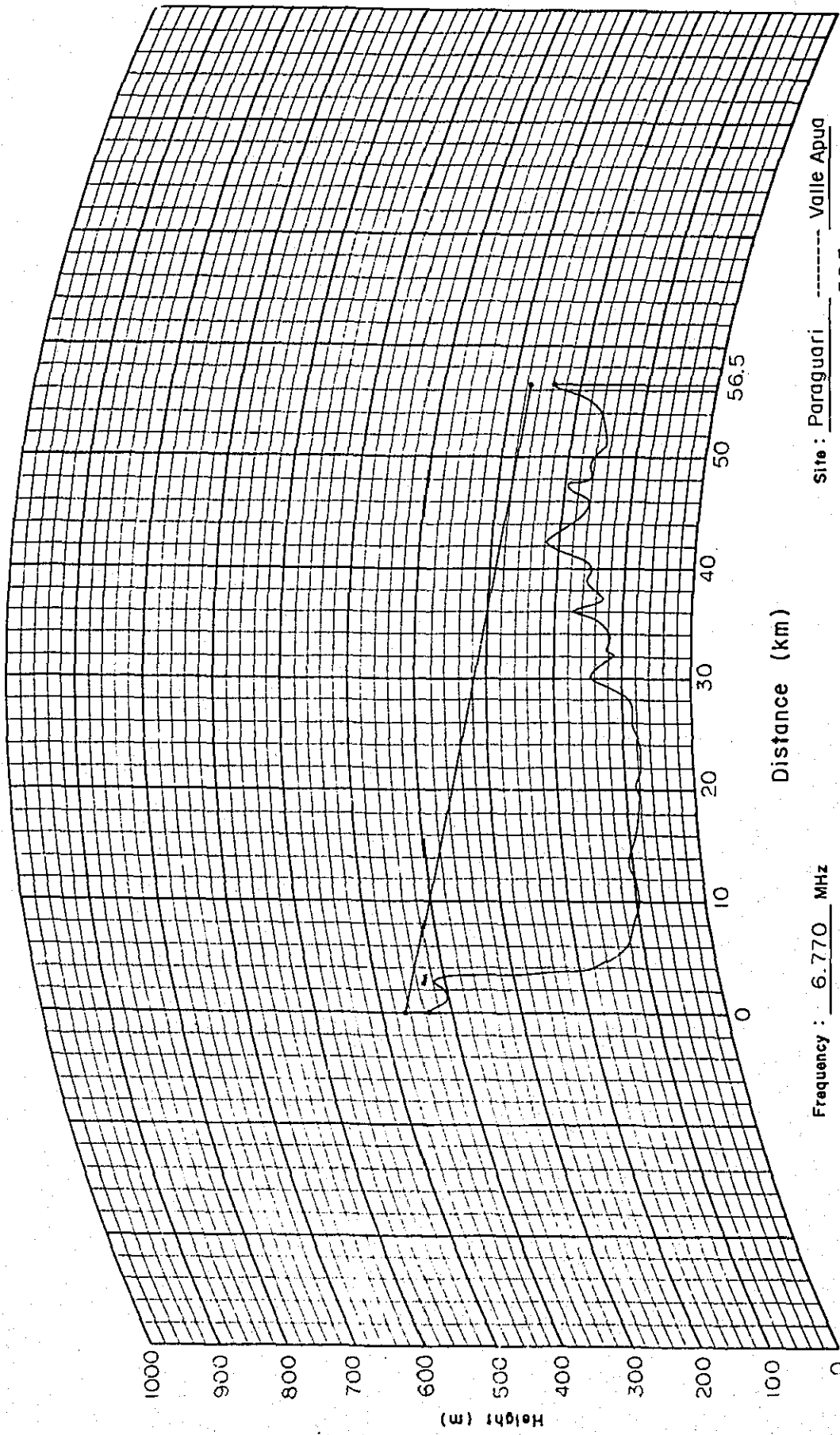

Frequency : 6.770 MHz

Distance (km)

Site : Paraguari ----- Valle Apua

Full Scale 120 km

Height : 430 m 56.5 km 240 m

Antenna : 35 m 35 m

Fig. 2-3 PATH PROFILE

(K=4/3)

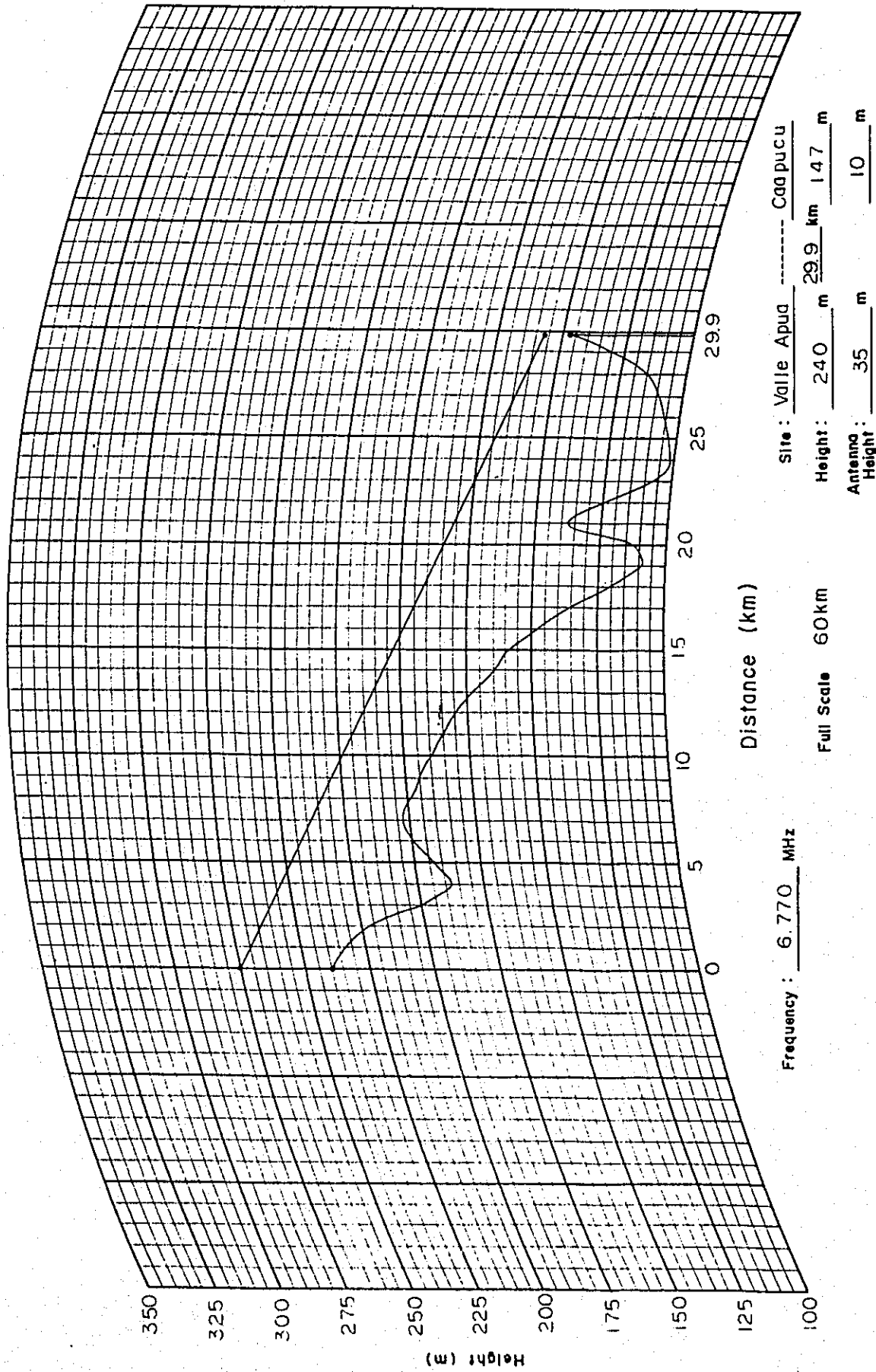

Fig. 24 PATH PROFILE

(K=4/3)

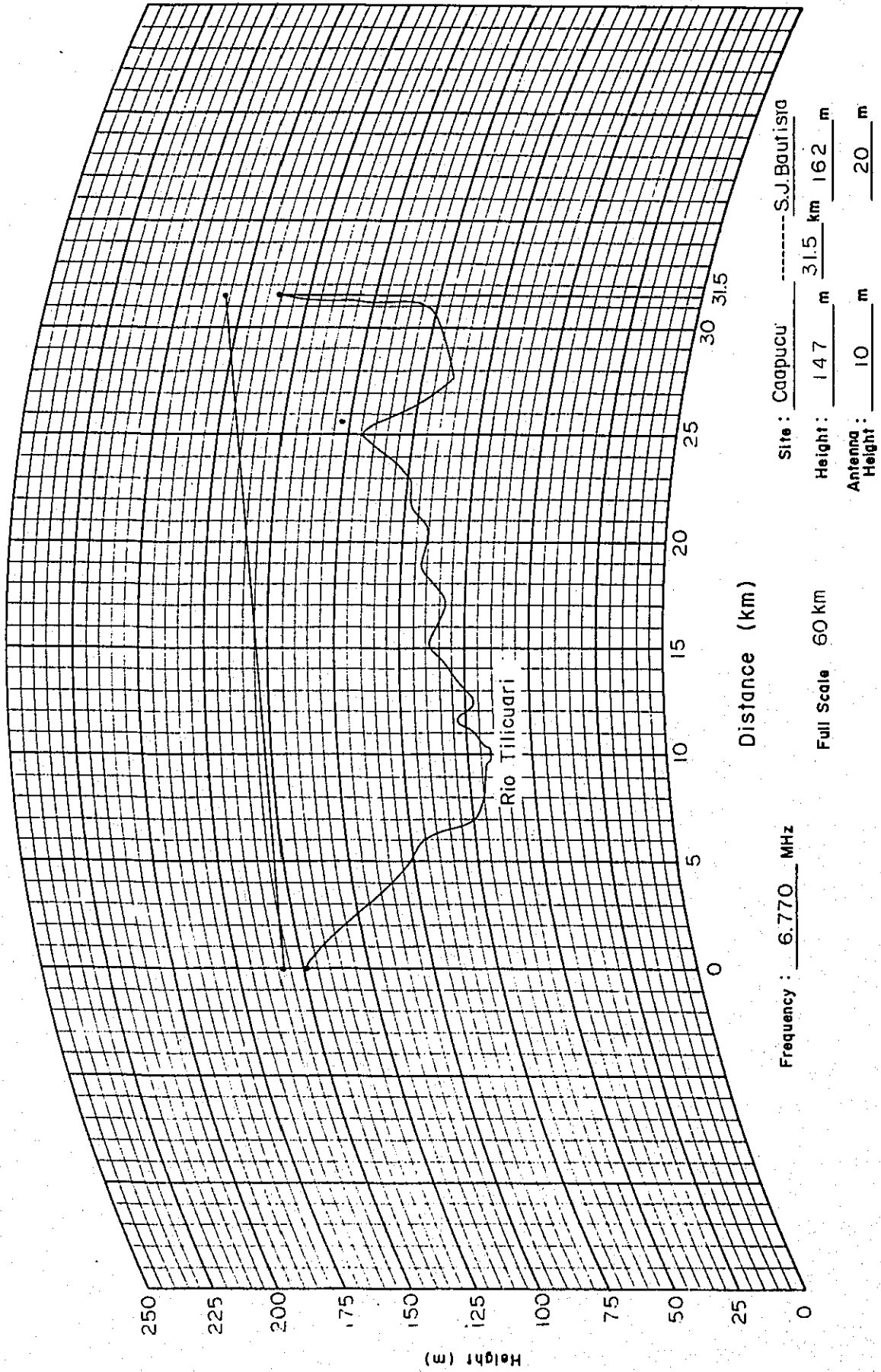
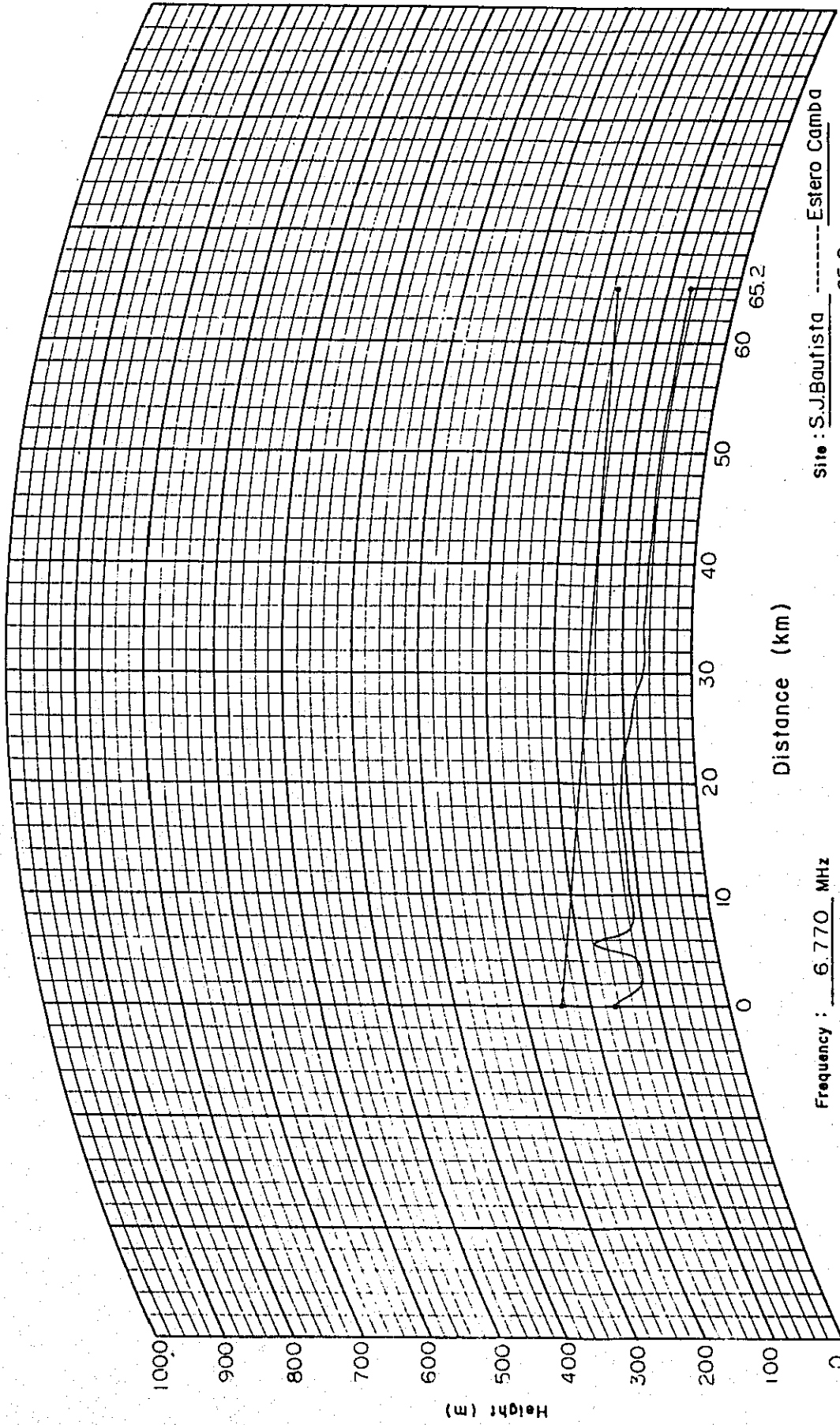

Fig. 2-5 PATH PROFILE

(K=4/3)



Frequency : 6.770 MHz

Site : S.J.Bautista ----- Estero Camba

Height : 162 m 65.2 km 64 m

Antenna : 80 m 110 m

Full Scale 120 km

Fig. 2-6 PATH PROFILE

(K=4/3)

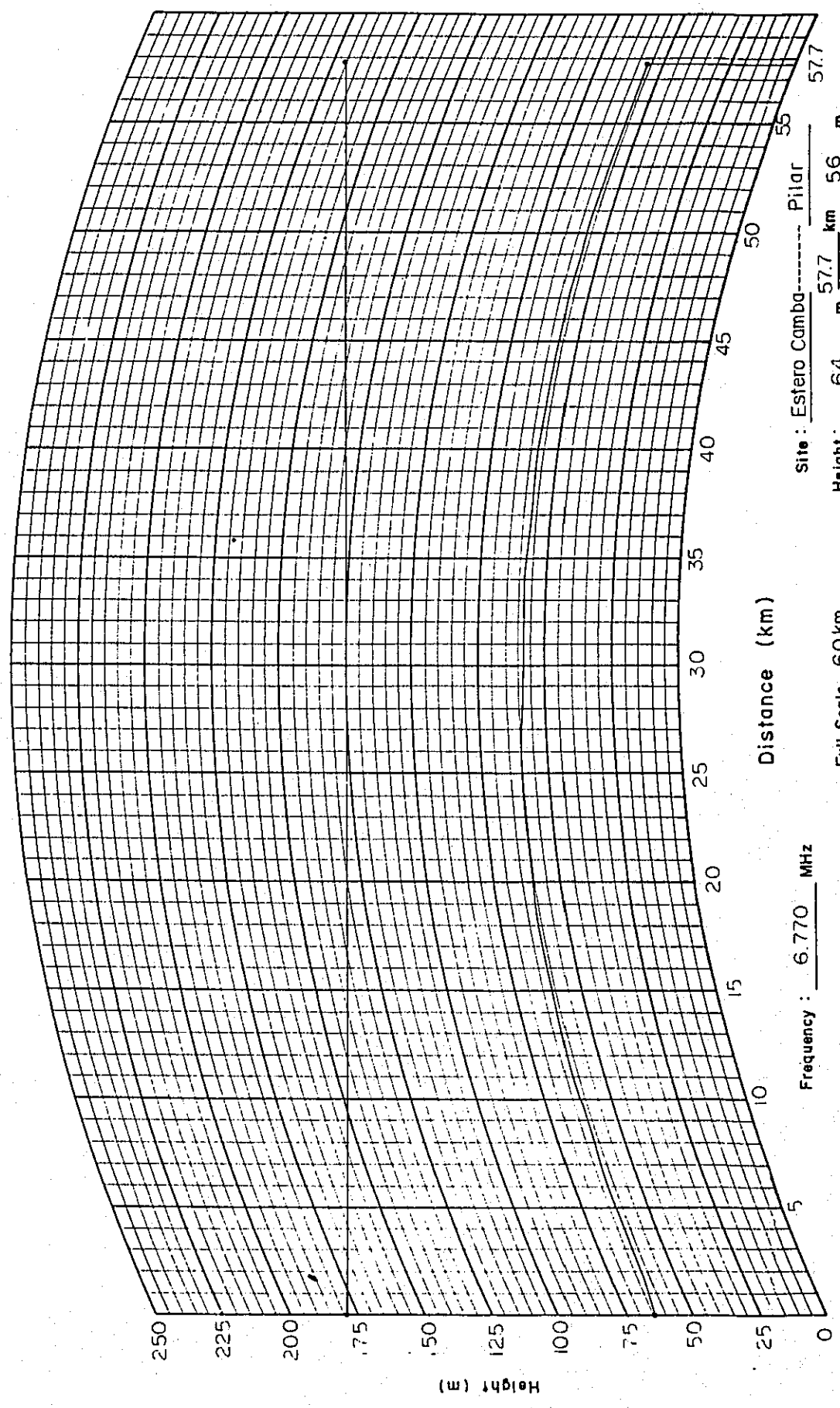

Site : Estero Camba----- Pillar 57.7
Height : 64 m 57.7 km 56 m
Antenna : 115 m 115 m
Height : 115 m 115 m

Frequency : 6.770 MHz
Full Scale 60 km

Fig. 2-7 PATH PROFILE

(K=4/3)

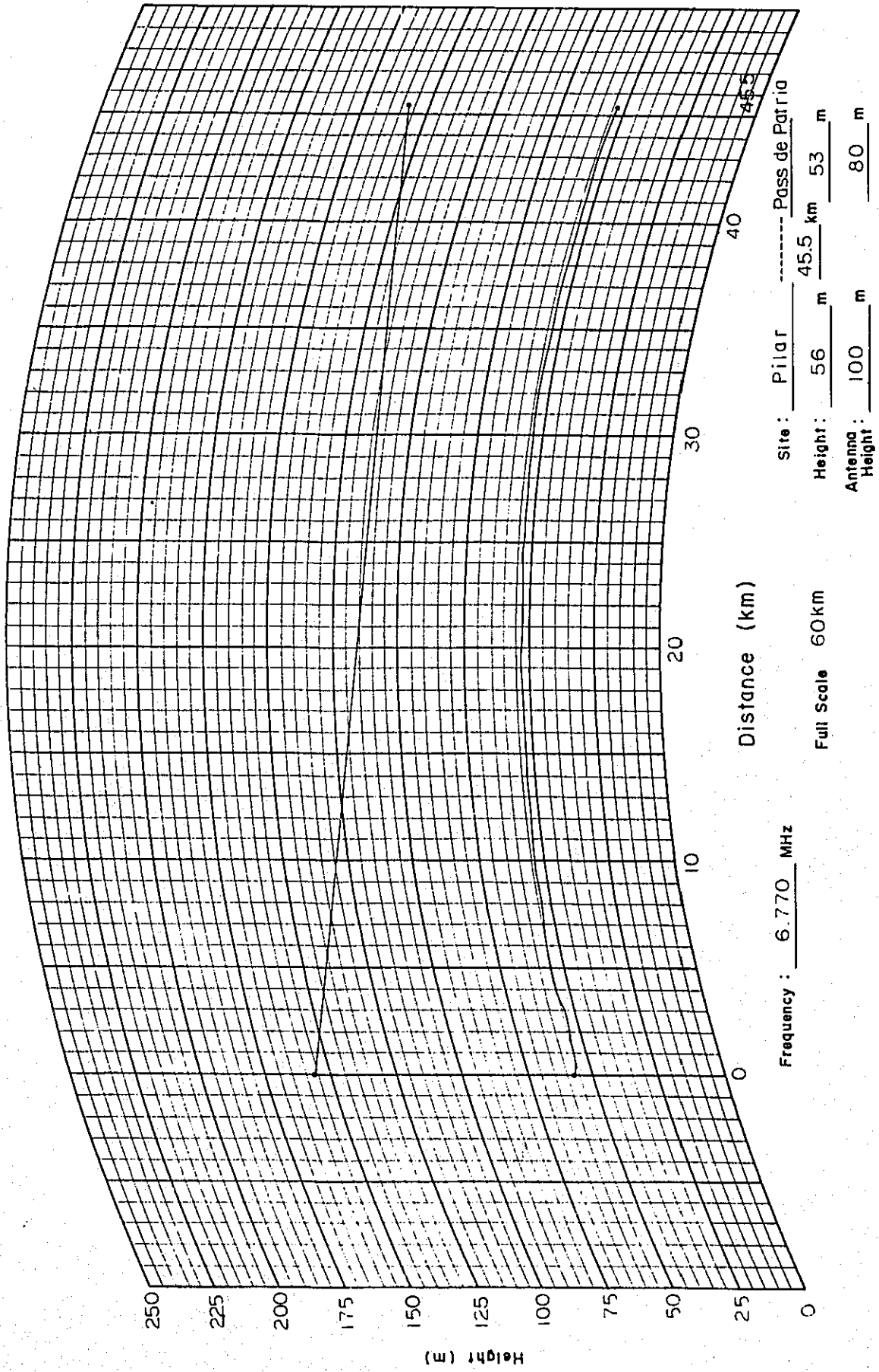
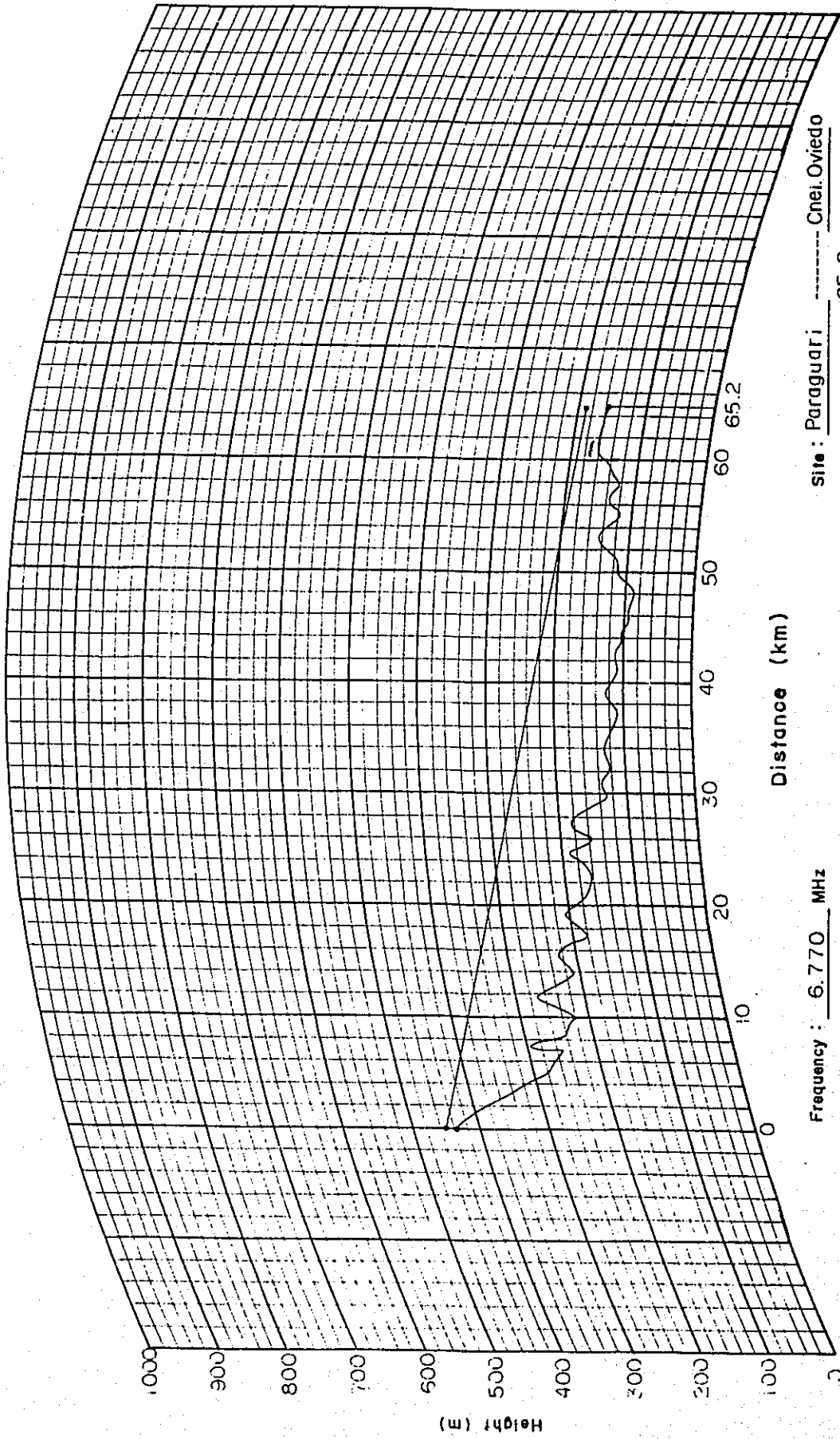

Fig. 2-8 PATH PROFILE

(K=4/3)



Frequency : 6.770 MHz
site : Paraguari ----- Cnei.Oviedo
Height : 430 m 65.2 km 160 m
Antenna : 25 m 30 m
Full Scale 120 km

Fig. 2-9 PATH PROFILE

(K=4/3)

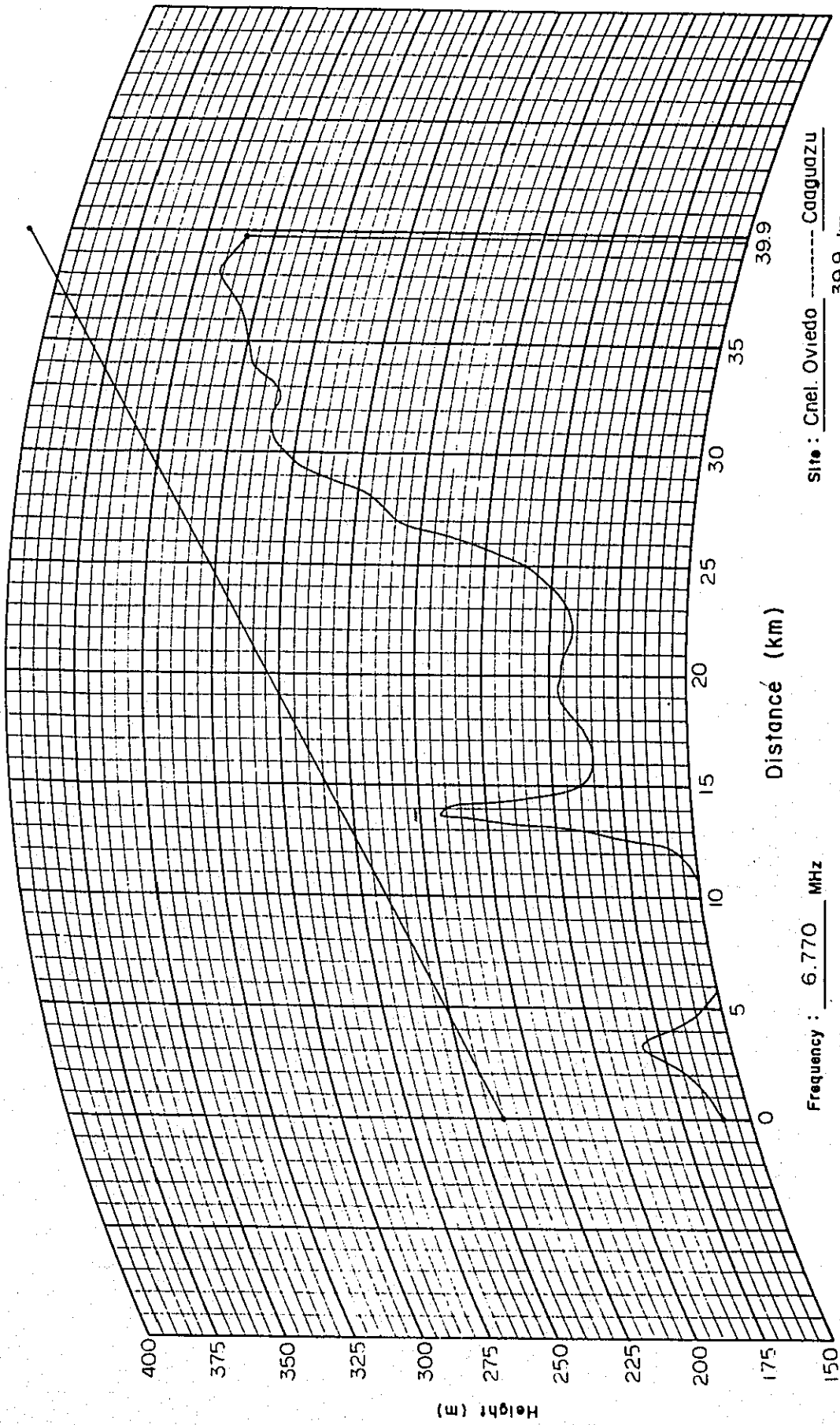

Frequency : 6.770 MHz

Site : Cnel. Oviedo ----- Caaguazú

Full Scale 60 km

Height : 160 m 39.9 km 335 m

Antenna Height : 80 m 80 m

Fig. 2-10 PATH PROFILE

(K=4/3)

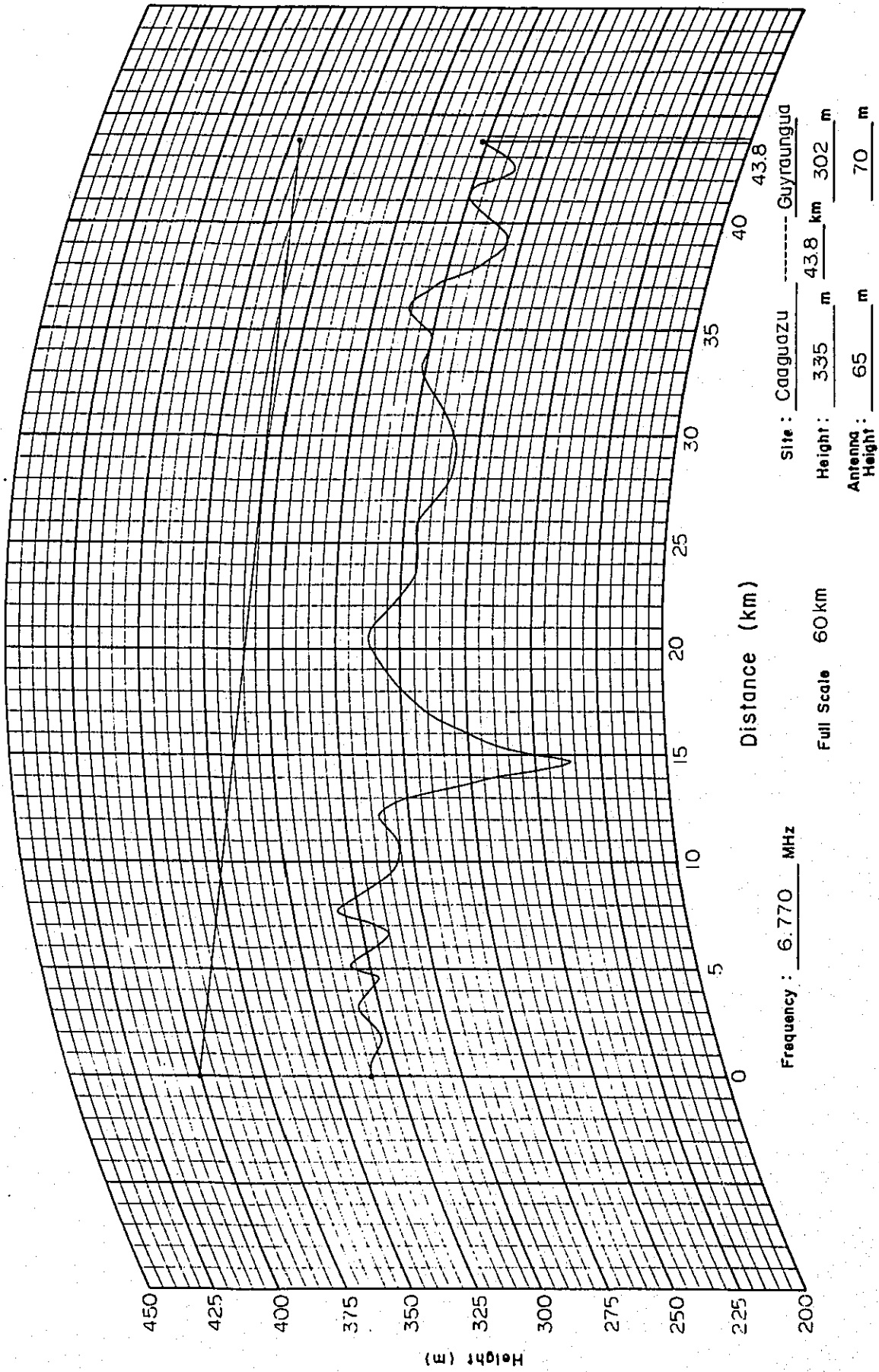
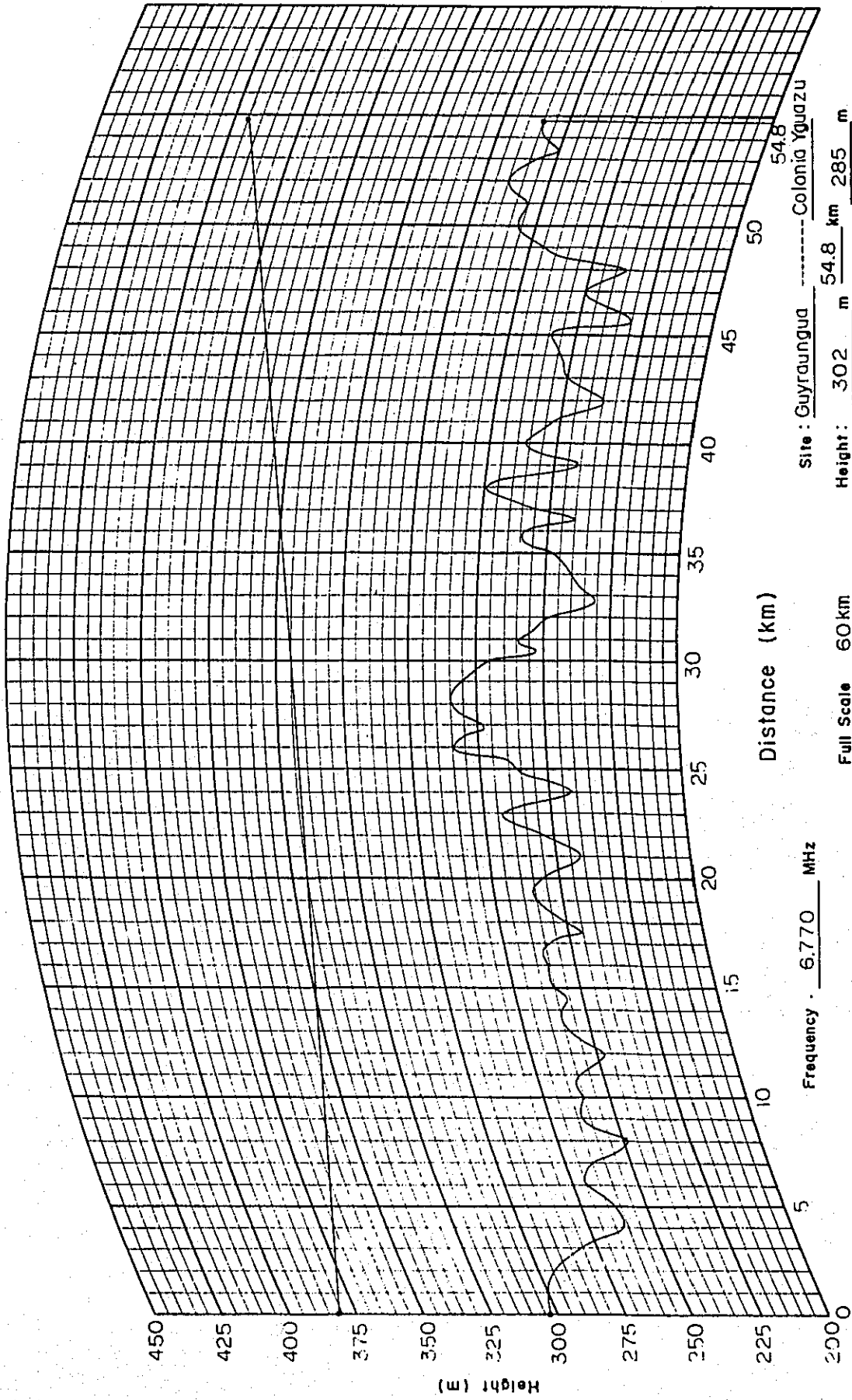

Fig. 2-11 PATH PROFILE

(K=4/3)



Site : Guyraungua ----- Colonia Yguazu
Height : 302 m 54.8 km 285 m
Antenna Height : 80 m 110 m

Frequency : 6.770 MHz

Full Scale 60 km

Fig. 2-12 PATH PROFILE

(K=4/3)

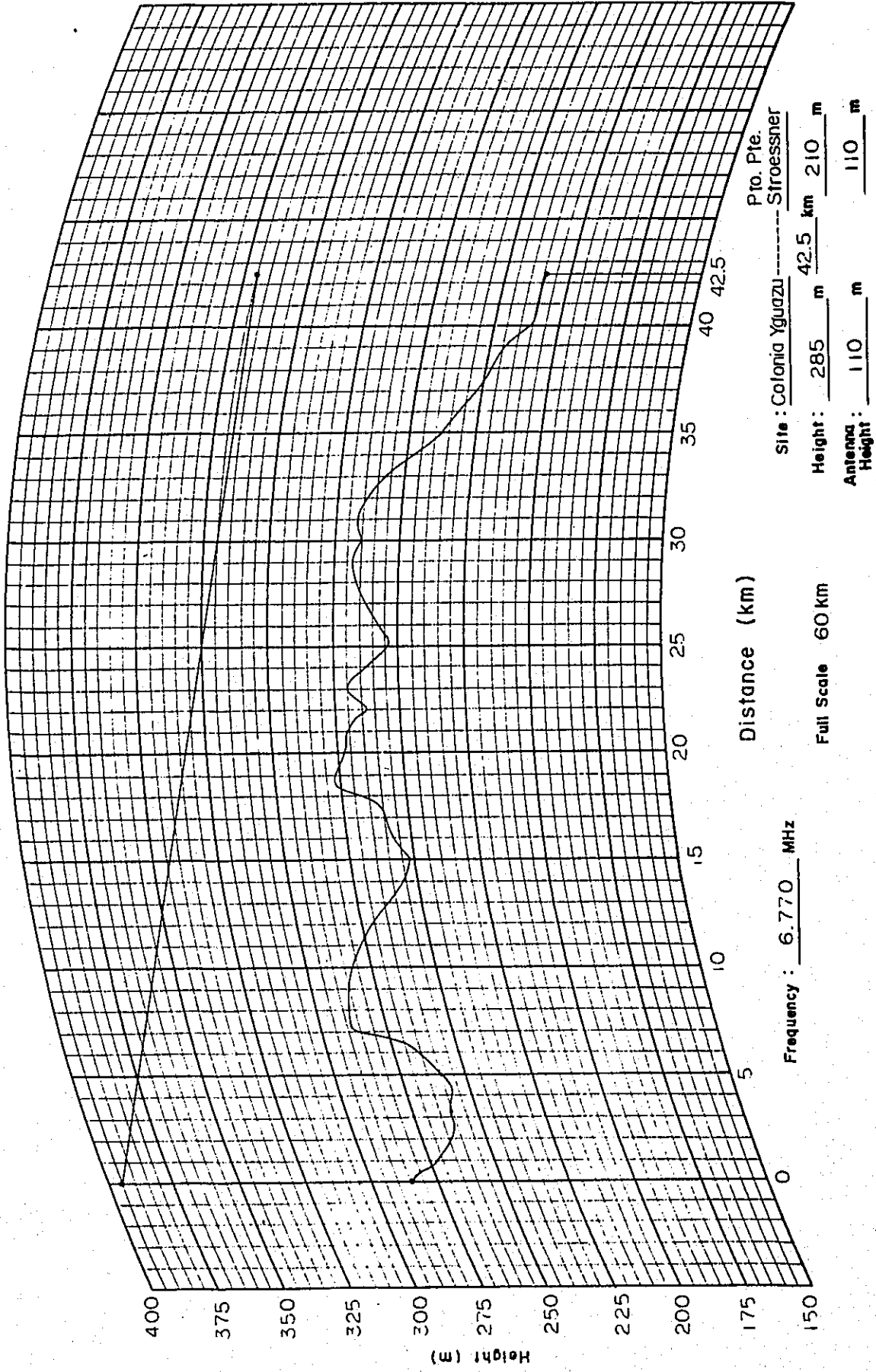

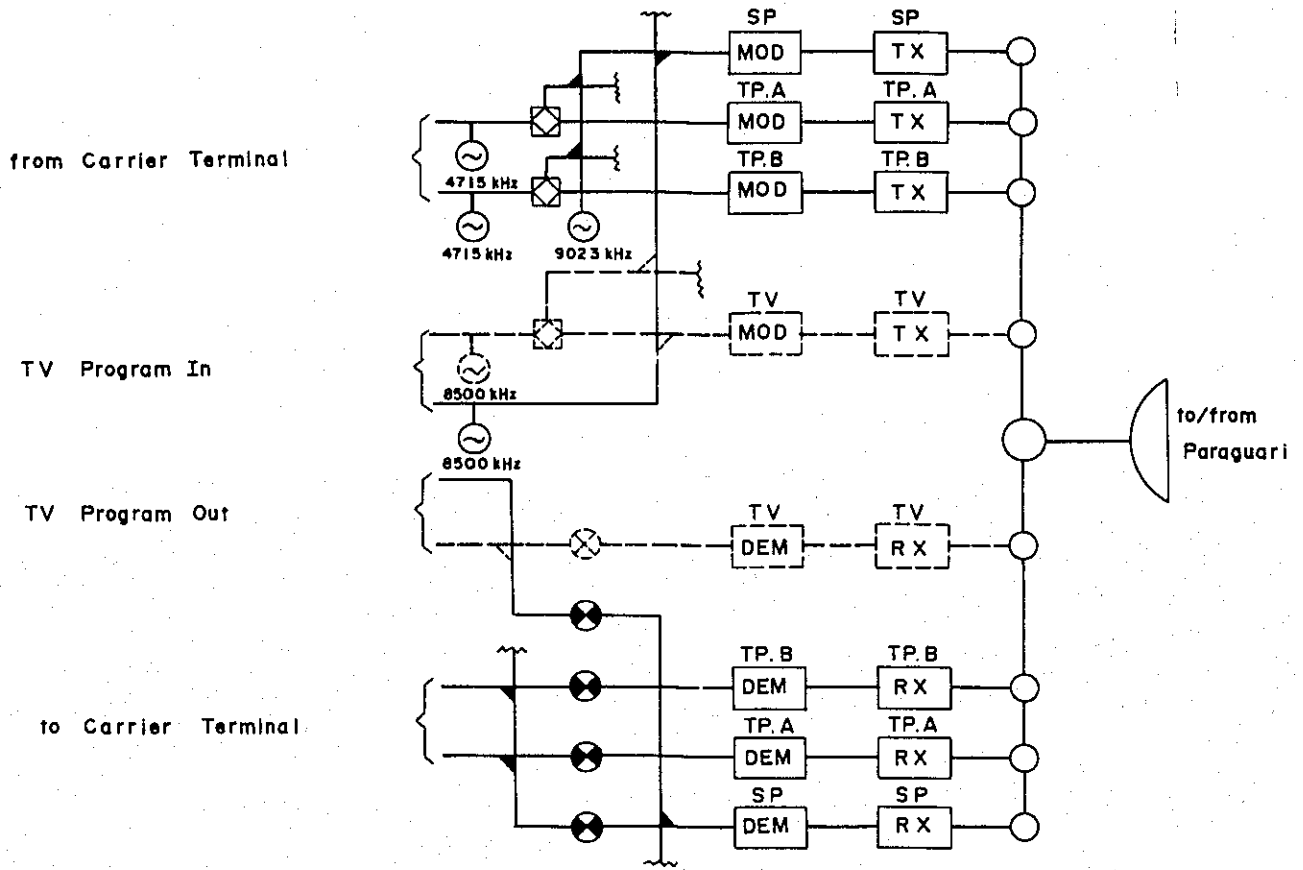

Fig. 2-13 Schematic Diagram of Terminal Station (Asuncion)

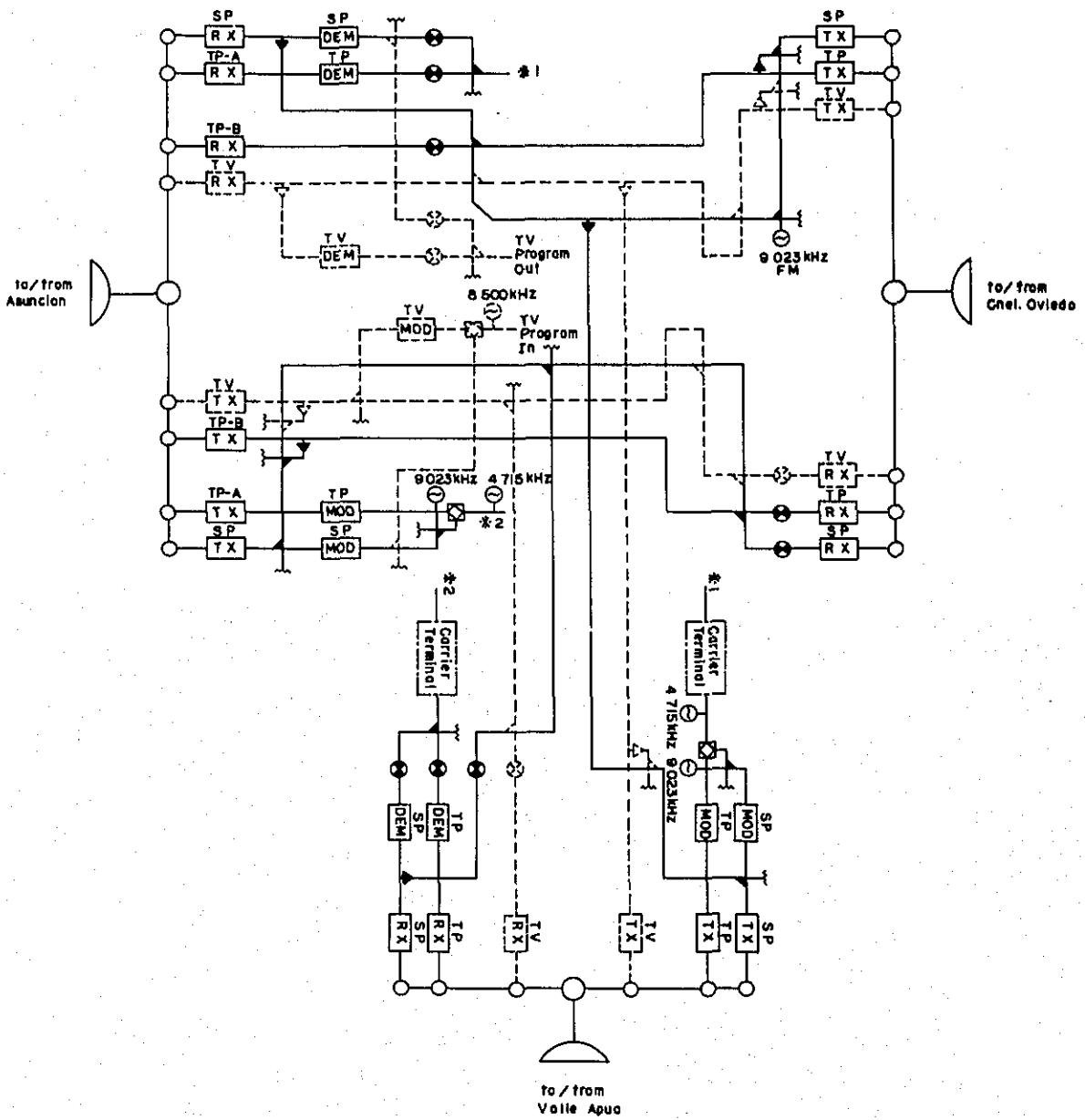

Fig. 2-14 Schematic Diagram of Terminal Station (Paraguari)

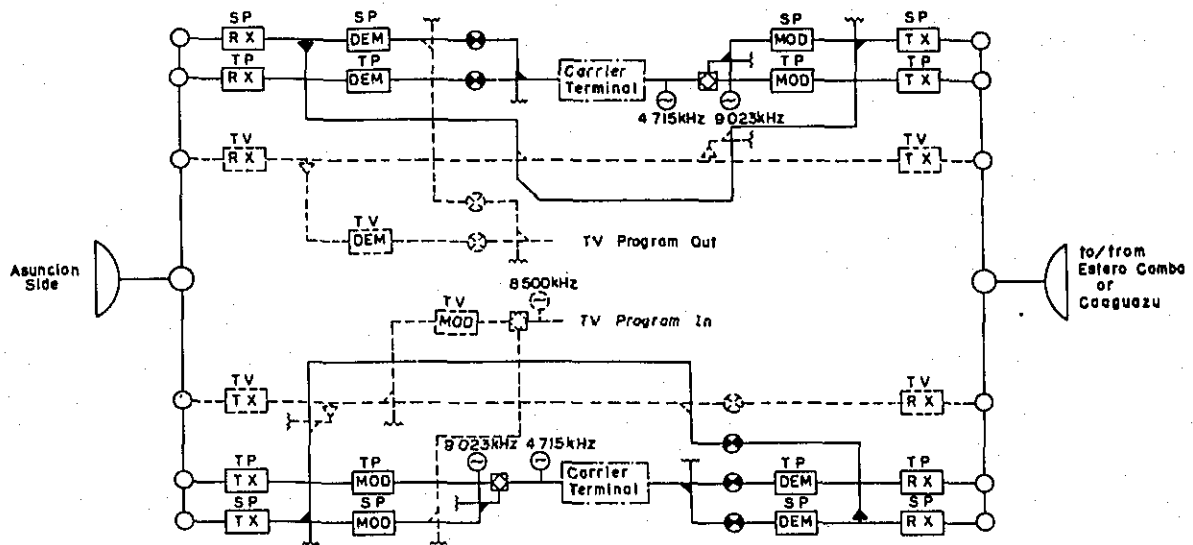

Fig. 2-15 Schematic Diagram of Terminal Station (Cnel. Oviedo, S. Juan Bautista) sta)

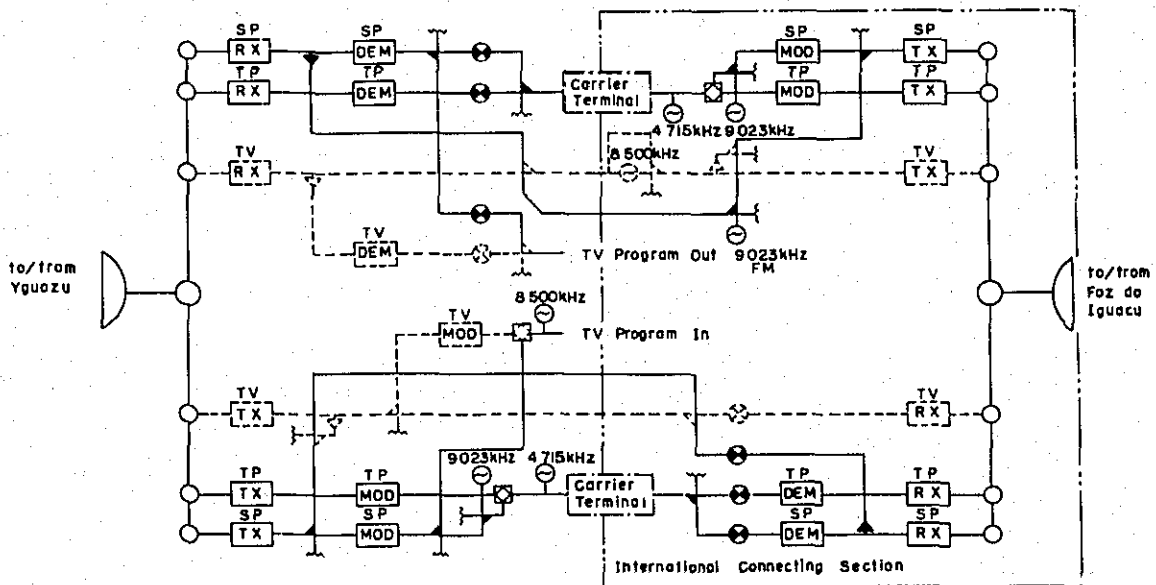

Fig. 2-16 Schematic Diagram of Terminal Station (Pro. Pte. Stroessner)

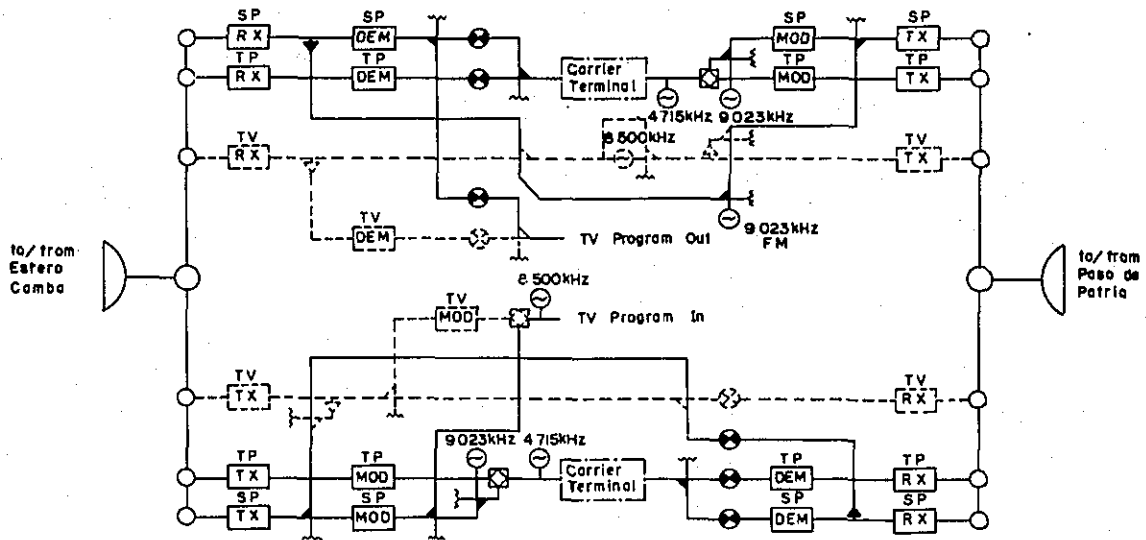

Fig. 2-17 Schematic Diagram of Terminal Station (Pilar)

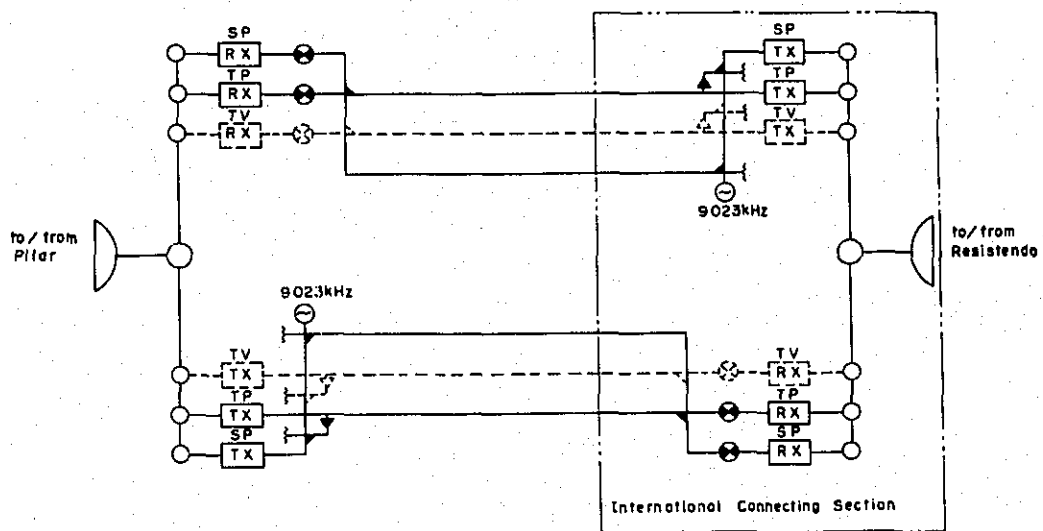

Fig. 2-18 Schematic Diagram of Repeater Station (Paso de Patria)

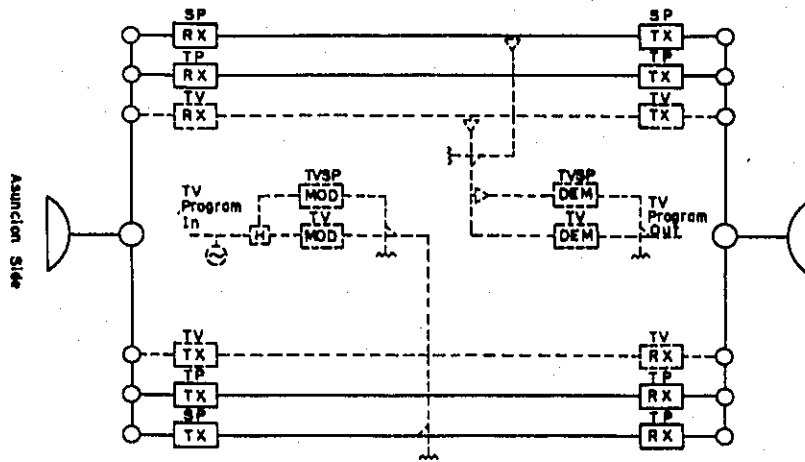

Fig. 2-19 Schematic Diagram of Repeater Station (Except Paso de Patrial)

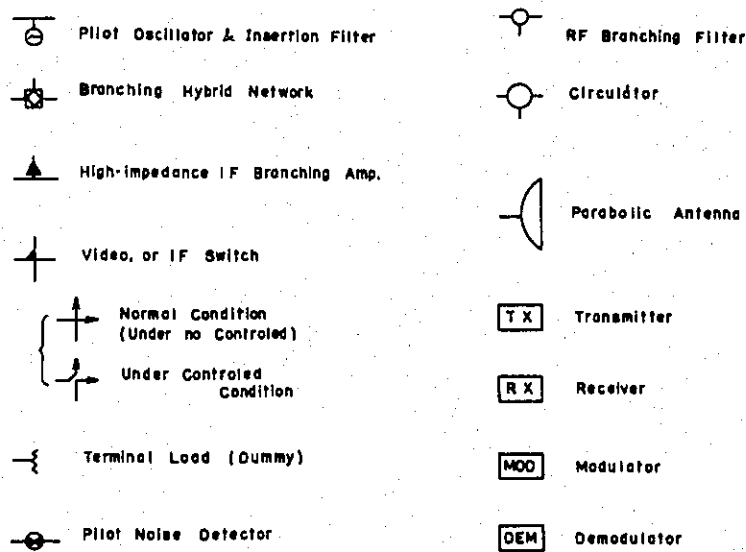

Fig. 2-20 Abbreviation

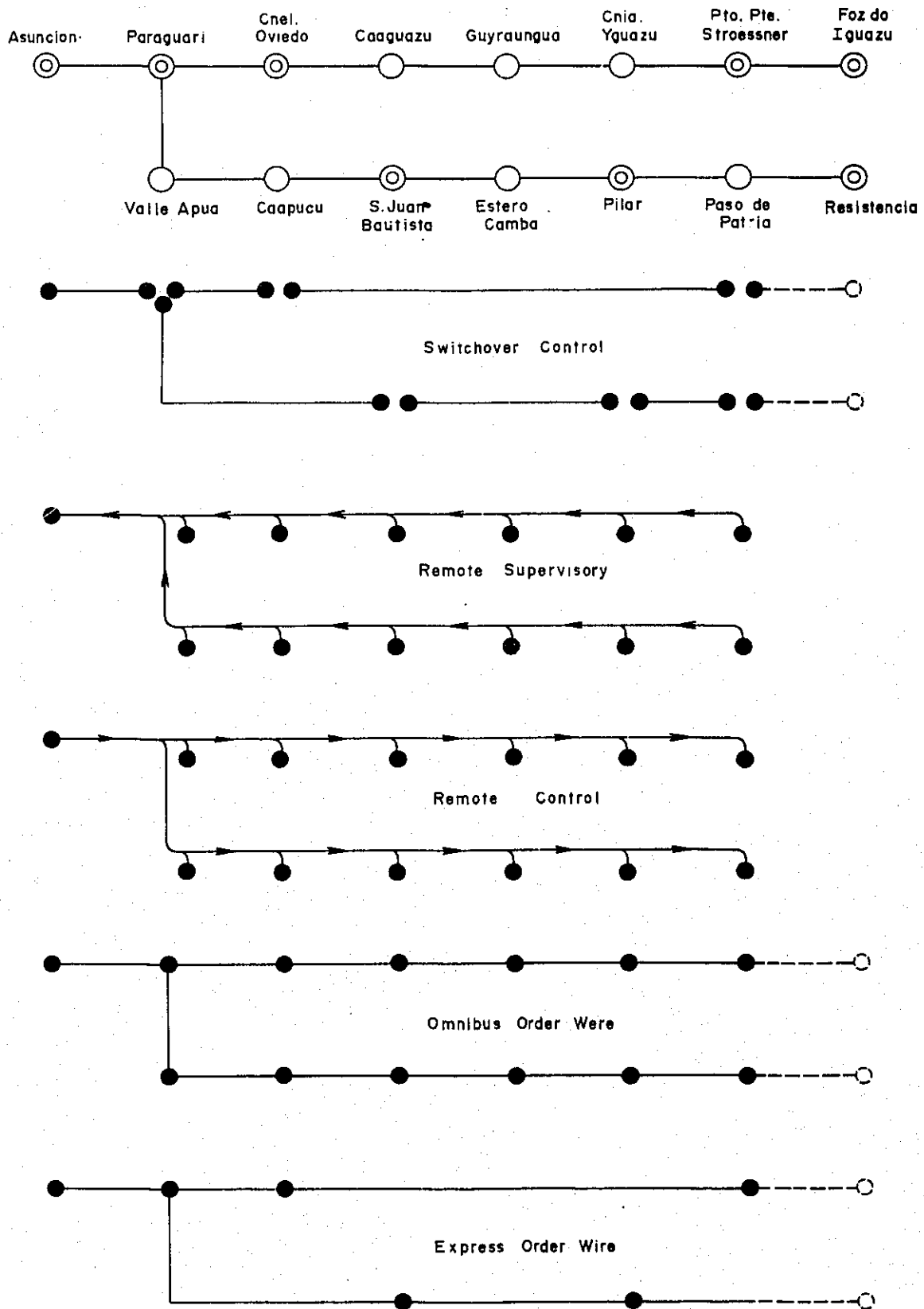

Fig. 2-21 Supervisory and Control System

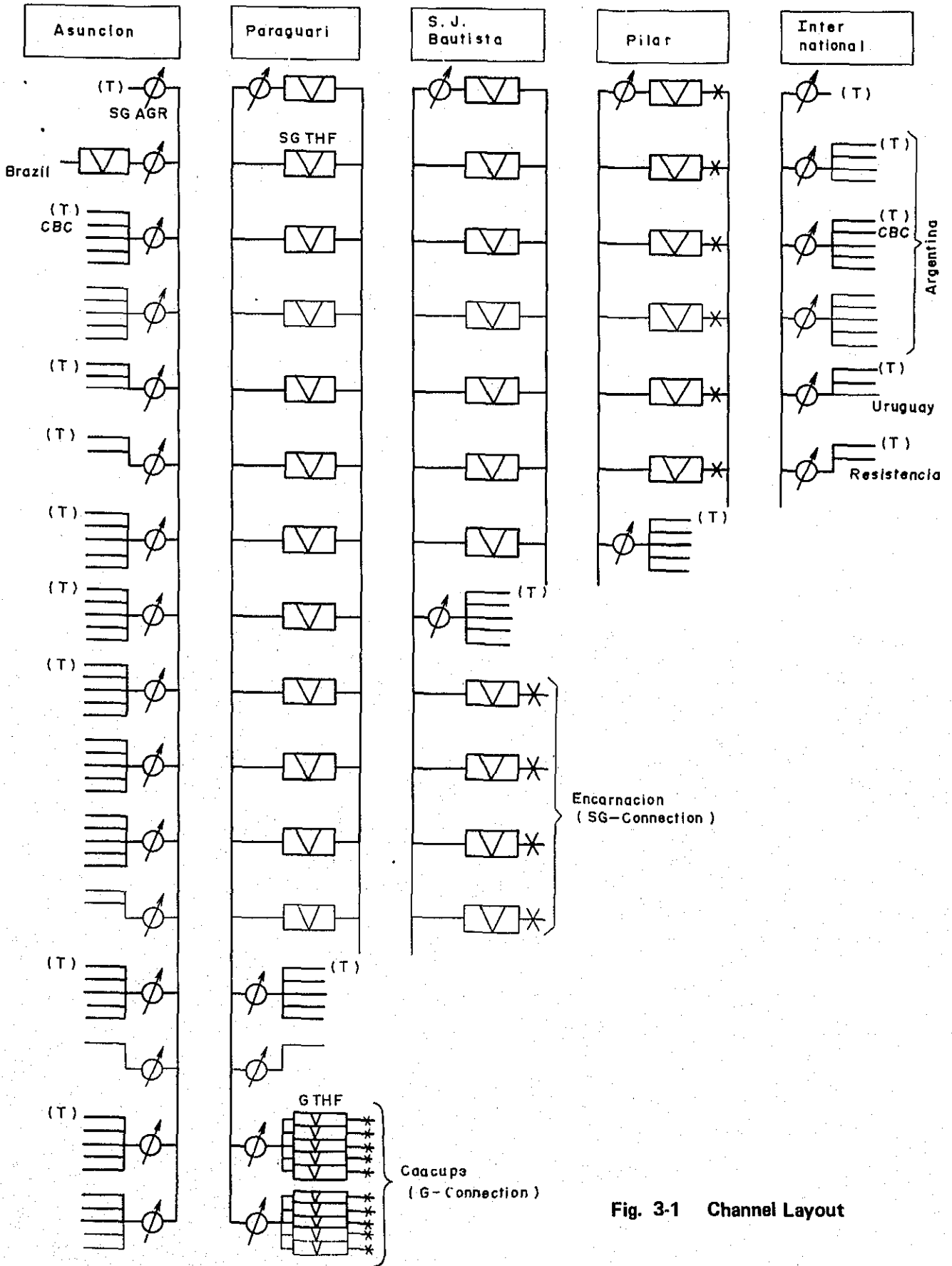
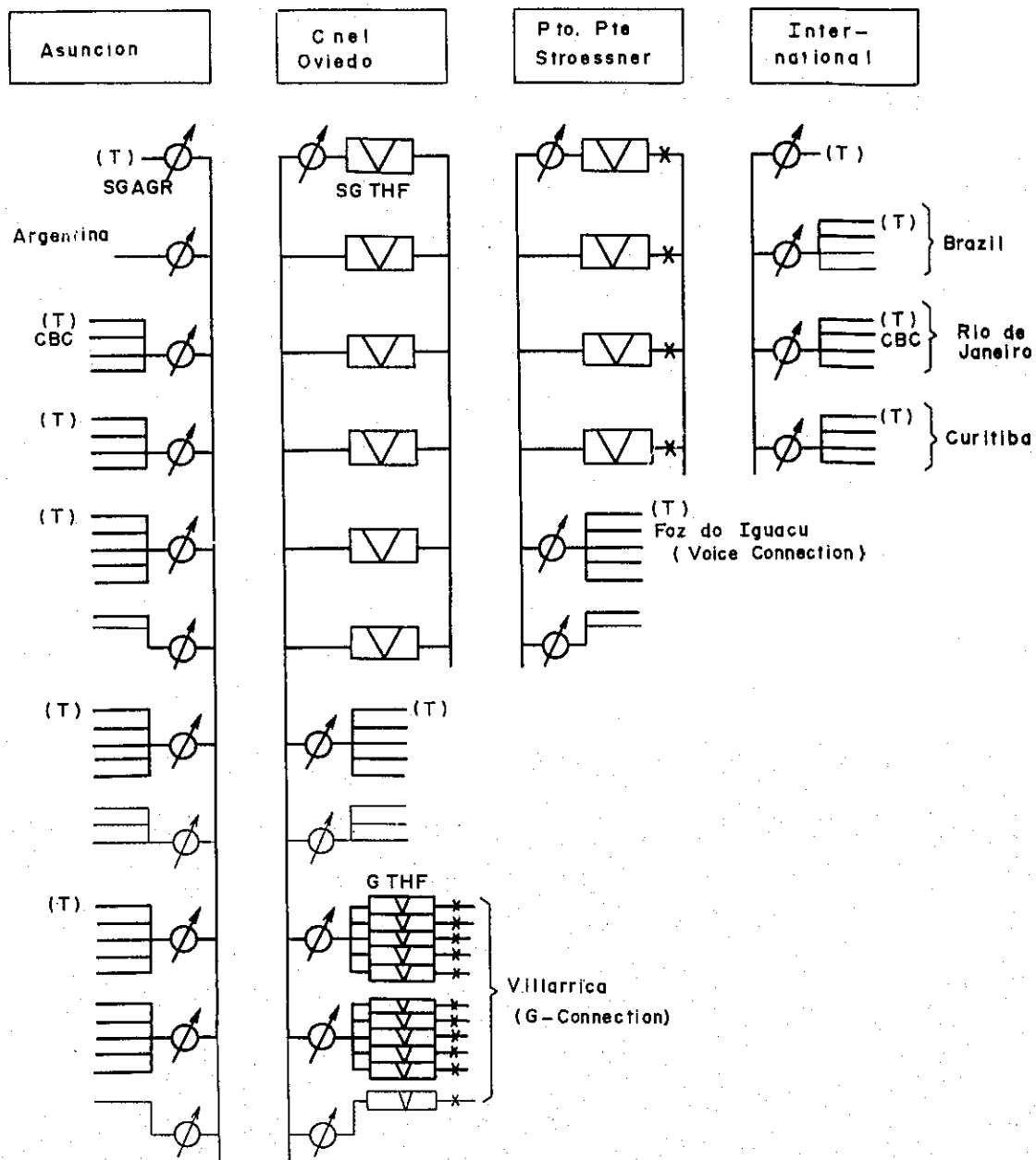

Fig. 3-1 Channel Layout



Note ;

1. Thick line means circuits in 1980
Thin line means circuits in 1990

2. SG ; Super-Group Translating Equipment
SG THF ; Super-Group Through Filter Equipment
SG AGR ; Super-Group Automatic Gain Regulator Equipment (at Receiving Side)
G ; Group Translating Equipment

G THF ; Group Through Filter Equipment

3. (T) ; SG or G for Spare and Test

4. * ; This mark shows the boundary of this project.

Fig. 3-2 Channel Layout

Table 3-1 Number of Circuits

	1980						1990			
	Telephone			Telegraph	CBC	Total	Telephone	Telegraph	CBC	Total
	R/D	Dialing	Total							
Argentina - Brazil	8		8			8	25			25
Asuncion - Argentina	28		28	15 (1)	1 (3)	32	93	33 (2)	1 (3)	98
Asuncion - Uruguay	5		5	5 (1)		6	12	10 (1)		13
Asuncion - Resistencia	4		4			4	5			5
Asuncion - Paraguari	2	41	43	1 (1)		44	54	3 (1)		55
Asuncion - Caacupe	3	78	81	2 (1)		82	104	4 (1)		105
Asuncion - S. J. Bautista	2	38	40	2 (1)		41	47	4 (1)		48
Asuncion - Encarnacion	5	155	160	4 (1)		161	183	7 (1)		184
Asuncion - Pilar	2	38	40	1 (1)		41	47	7 (1)		48
Total	59	350	409	30 (7)	1 (3)	419	570	68 (8)	1 (3)	581
Argentina - Brazil	8		8			8	25			25
Asuncion - Rio de Janeiro	13		13	10 (1)	1 (3)	17	16	16 (1)	1 (3)	20
Asuncion - Curitiba	25		25			25	32			32
Asuncion - Foz do Iguacu	2		2			2	3			3
Asuncion - Coronel Oviedo	2	41	43	2 (1)		44	74	3 (1)		75
Asuncion - Villarrica	3	96	99	3 (1)		100	114	7 (1)		115
Asuncion - P. P. Stroessner	2	41	43	2 (1)		44	50	3 (1)		51
Total	55	178	233	17 (4)	1 (3)	240	314	29 (4)	1 (3)	321

Note: This table does not include Spare Channel.

The values in parenthesis are converted into Telephone - Channels]]

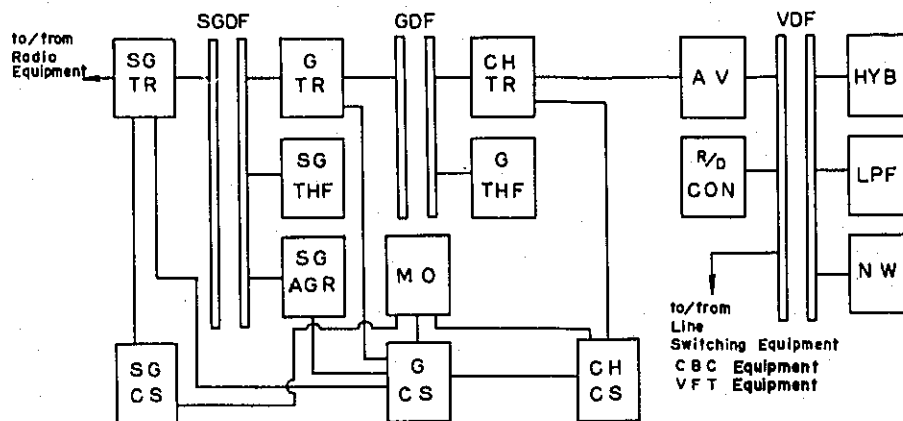

Legend;

- | | |
|------------------------------------------------|---------------------------------------------|
| 1. SG. TR ; Super-Group Translating Equipment | 9. GDF ; Group Distribution Frame |
| 2. SG. CS ; SG. Carrier Supply Equipment | 10. CH.TR; Channel Translating Equipment |
| 3. SG. AGR; SG. Automatic Gain Regulating Equ. | 11. CH.CS; Channel Carrier Supply Equipment |
| 4. SG. THF; SG. Through Filter | 12. HYB ; 2W/W Translating Equipment |
| 5. SG. DF; SG. Distribution Frame | 13. R/D REP; R/D Converter Equipment |
| 6. G TR ; Group Translating Equipment | 14. LPF ; Low Pass Filter |
| 7. G CS ; Group Carrier Supply Equipment | 15. AV ; Variable Attenuator |
| 8. G THF; Group Through Filter | 16. NW ; Network |
| | 17. VDF ; Voice Distribution Frame |
| | 18. MO ; Master Oscillator |

Fig. 3-3. Typical Carrier Multiplex System Block Diagram

Table 4-1 Toll Cable System

Section	Approx. Distance	Type of Cable	Diameter of Conductor	Number of Pairs	Loaded or Non-loaded	Type of Construction
Paraguari R. T. S. ~ Paraguari T. O.	11 km	PEF-P	0.9 mm	150	Loaded	Aerial
S. J. Bautista R. T. S. ~ S. J. Bautista T. O.	11 km	PEF-P	0.9 mm	100	Loaded	Aerial
Cnel. Oviedo R. T. S. ~ Cnel. Oviedo. T. O.	1.5 km	PEF-P	0.65 mm	150	Non-loaded	Aerial
P. P. Stroessner R. T. S. ~ P. P. Stroessner. T. O.	2.0 km	PEF-P	0.65 mm	150	Non-loaded	Aerial

Note: R. T. S. : Radio Terminal Station

T. O. : Telephone Office

PEF-P: Formed Polyethylene Insulated-Polyethylene Sheath Cable

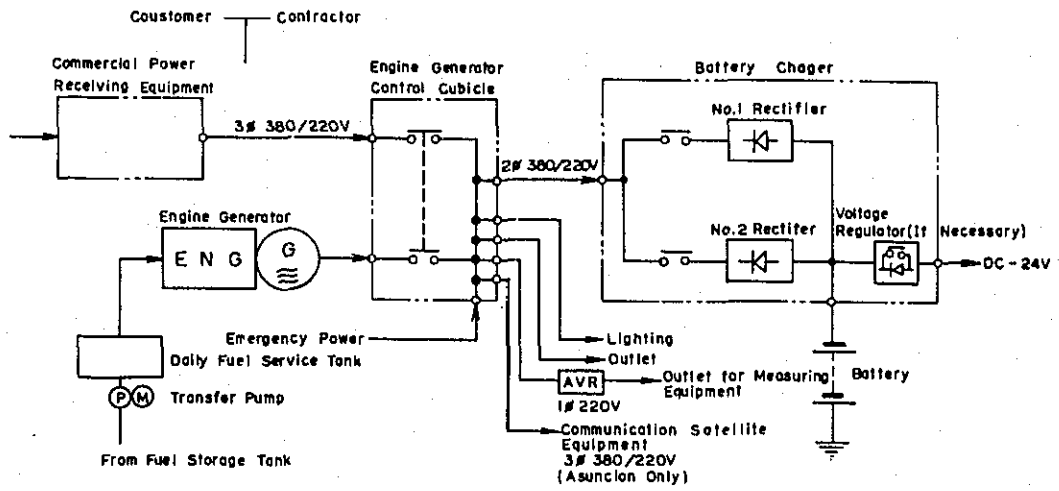

Fig. 6-1 Power Supply System-I (Commercial Power is Available)

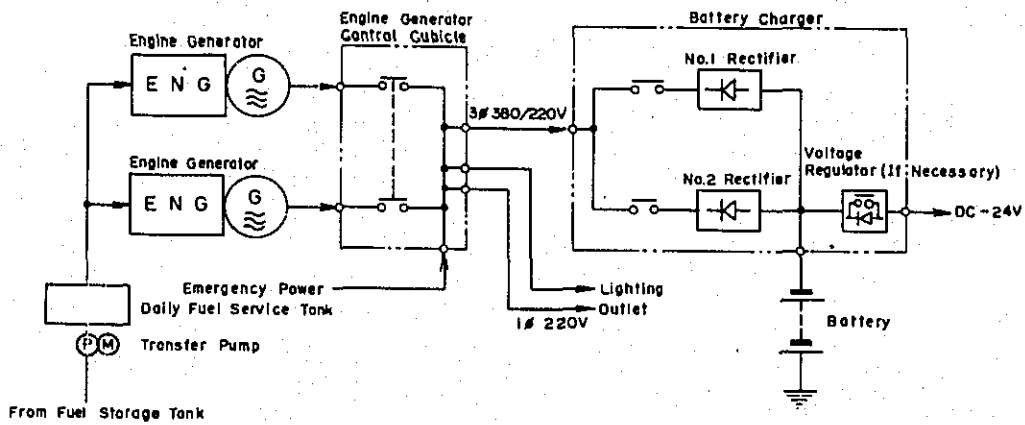

Fig. 6-2 Power Supply System-II (Commercial Power is Unavailable)

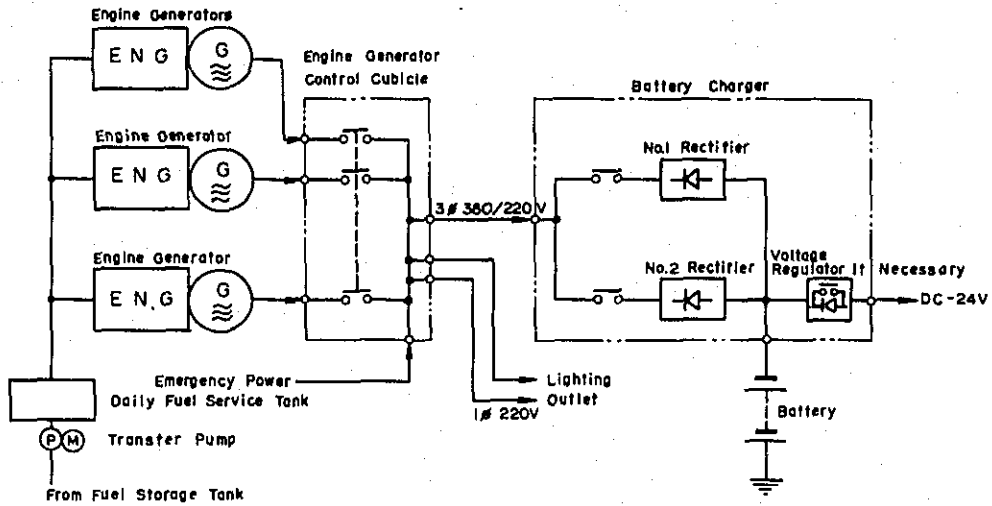

Fig. 6-3 Power Supply System- III (Commercial Power is Unavailable)

Table 7-1 Measuring Equipment

	Asuncion	Paraguari	Valle Apua	Capuciu	San Juan Bautista	Estero Camba	Pilar	Paso de Patria	Cnel. Oviedo	Caaguazu	Guyraangua	Colonia Yguazu	Pro. Pre. Schroesner	Training Center
MULT M	1	1	1	1	1	1	1	1	1	1	1	1	1	1
TESTER	1	1	1	1	1	1	1	1	1	1	1	1	1	1
MEG	1	1	1	1	1	1	1	1	1	1	1	1	1	1
HV	1	1	1	1	1	1	1	1	1	1	1	1	1	1
OSCILLO	1	1	1	1	1	1	1	1	1	1	1	1	1	1
REC	1	1	1	1	1	1	1	1	1	1	1	1	1	1
BSG	1	1	1	1	1	1	1	1	1	1	1	1	1	1
BLM	1	1	1	1	1	1	1	1	1	1	1	1	1	1
NM	1	1	1	1	1	1	1	1	1	1	1	1	1	1
TVSG	1	1	1	1	1	1	1	1	1	1	1	1	1	1
TVM	1	1	1	1	1	1	1	1	1	1	1	1	1	1
LIN	1	1	1	1	1	1	1	1	1	1	1	1	1	1
DELAY	1	1	1	1	1	1	1	1	1	1	1	1	1	1
AMP	1	1	1	1	1	1	1	1	1	1	1	1	1	1
DEV	1	1	1	1	1	1	1	1	1	1	1	1	1	1
RFM	1	1	1	1	1	1	1	1	1	1	1	1	1	1
RFBM	1	1	1	1	1	1	1	1	1	1	1	1	1	1
IFSG	1	1	1	1	1	1	1	1	1	1	1	1	1	1
IFLM	1	1	1	1	1	1	1	1	1	1	1	1	1	1
REP	1	1	1	1	1	1	1	1	1	1	1	1	1	1
SC	1	1	1	1	1	1	1	1	1	1	1	1	1	1
MM	1	1	1	1	1	1	1	1	1	1	1	1	1	1
CSG	1	1	1	1	1	1	1	1	1	1	1	1	1	1
ASG	1	1	1	1	1	1	1	1	1	1	1	1	1	1
CLM	1	1	1	1	1	1	1	1	1	1	1	1	1	1
ALM	1	1	1	1	1	1	1	1	1	1	1	1	1	1
SLM	1	1	1	1	1	1	1	1	1	1	1	1	1	1
PSO	1	1	1	1	1	1	1	1	1	1	1	1	1	1
IS	1	1	1	1	1	1	1	1	1	1	1	1	1	1
VTM	2	2	2	2	2	2	2	2	2	2	2	2	2	2
TDM	2	2	2	2	2	2	2	2	2	2	2	2	2	2
Portable 3V Voltmeter	1	1	1	1	1	1	1	1	1	1	1	1	1	1
Syringe Hydrometer	1	1	1	1	1	1	1	1	1	1	1	1	1	1
Battery Thermometer	1	1	1	1	1	1	1	1	1	1	1	1	1	1
Tachometer	1	1	1	1	1	1	1	1	1	1	1	1	1	1

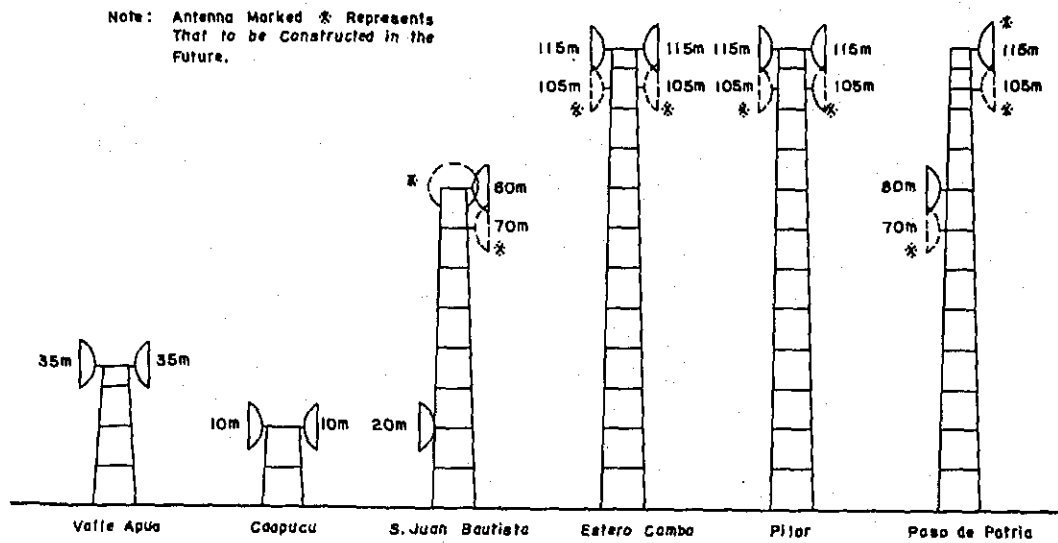

Fig. 9-1 Conceptual Figure of the Tower with Antenna

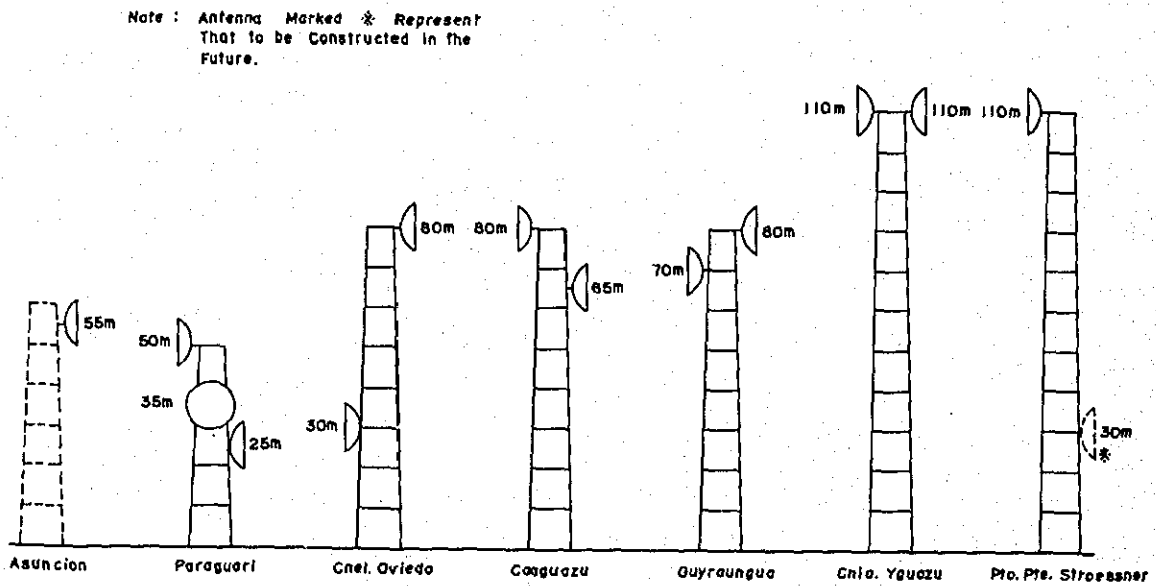

Fig. 9-2 Conceptual Figure of the Tower with Antenna