

REPUBLIC OF INDONESIA  
MINISTRY OF COMMUNICATIONS  
DIRECTORATE GENERAL OF LAND TRANSPORT  
AND INLAND WATERWAYS

**TENDER DOCUMENTS  
FOR  
NEW RAILWAY LINE FOR CENGKARENG AIRPORT  
CONSTRUCTION PROJECT**

**PACKAGE I CIVIL AND ARCHITECTURAL WORK**

PART F DRAWINGS

2 of 3

AUGUST 1984

**JAPAN INTERNATIONAL COOPERATION AGENCY  
(JICA)**

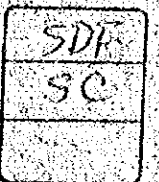
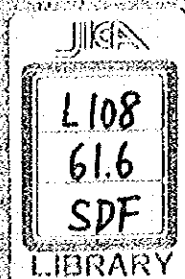

116

JICA LIBRARY  
103433903

REPUBLIC OF INDONESIA  
MINISTRY OF COMMUNICATIONS  
DIRECTORATE GENERAL OF LAND TRANSPORT  
AND INLAND WATERWAYS

**TENDER DOCUMENTS  
FOR  
NEW RAILWAY LINE FOR CENGKARENG AIRPORT  
CONSTRUCTION PROJECT**

**PACKAGE I CIVIL AND ARCHITECTURAL WORK**

PART F DRAWINGS

2 of 3

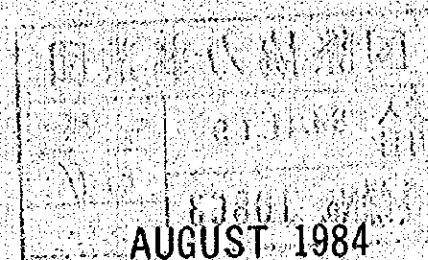

**JAPAN INTERNATIONAL COOPERATION AGENCY  
(JICA)**

REPUBLIC OF INDONESIA  
MINISTRY OF COMMUNICATIONS  
DIRECTORATE GENERAL OF LAND TRANSPORT  
AND INLAND WATERWAYS

TENDER DOCUMENTS  
FOR  
NEW RAILWAY LINE FOR CENKABENGA AIRPORT  
CONSTRUCTION PROJECT

PACKAGE 1 CIVIL AND ARCHITECTURAL WORK  
PART 1 DRAWINGS

8 of 8

国際協力事業団	
受入 月日 '84.11.19	L108
登録No. 10863	61.6
	SDF

引取品

JAPAN INTERNATIONAL COOPERATION AGENCY

(A01)

## INDEX OF DRAWING

DWG. No.	TITLE	DWG. No.	TITLE
CS-001	BRIDGE B01 GENERAL VIEW	CS-032	P.C. GIRDER PC04 REINF. BAR SCHEDULE
002	BRIDGE B02 GENERAL VIEW	033	P.C. GIRDER PC05 GENERAL VIEW
003	BRIDGE B03 GENERAL VIEW (SHEET 1 OF 2)	034	P.C. GIRDER PC06 GENERAL VIEW
004	— DO — (SHEET 2 OF 2)	035	— DO — P.C. CABLE AND REINF. BAR ARRANGEMENT OF MAIN BEAM
005	BRIDGE B04 GENERAL VIEW	036	— DO — P.C. CABLE AND REINF. BAR ARRANGEMENT OF LATERAL JOINT
006	BRIDGE B05 GENERAL VIEW (SHEET 1 OF 3)	037	— DO — REINF. BAR SCHEDULE
007	— DO — (SHEET 2 OF 3)	038	P.C. GIRDER PC13 GENERAL VIEW
008	— DO — (SHEET 3 OF 3)	039	P.C. GIRDER PC15 GENERAL VIEW
009	BRIDGE B06 GENERAL VIEW	040	— DO — P.C. CABLE AND REINF. BAR ARRANGEMENT OF MAIN BEAM
010	BRIDGE B07 GENERAL VIEW	041	— DO — P.C. CABLE AND REINF. BAR ARRANGEMENT OF LATERAL JOINT
011	BRIDGE B08 GENERAL VIEW (SHEET 1 OF 2)	042	— DO — REINF. BAR SCHEDULE
012	— DO — (SHEET 2 OF 2)	043	P.C. GIRDER PC17 GENERAL VIEW
013	BRIDGE B09 GENERAL VIEW	044	P.C. GIRDER PC24 GENERAL VIEW
014	BRIDGE B10 GENERAL VIEW	045	P.C. GIRDER PC28 GENERAL VIEW
015	BRIDGE B11 GENERAL VIEW	046	— DO — P.C. CABLE AND REINF. BAR ARRANGEMENT OF MAIN BEAM
016	BRIDGE B12 GENERAL VIEW (SHEET 1 OF 2)	047	— DO — P.C. CABLE AND REINF. BAR ARRANGEMENT OF LATERAL JOINT
017	— DO — (SHEET 2 OF 2)	048	— DO — REINF. BAR SCHEDULE
018	BRIDGE B13 GENERAL VIEW	049	P.C. GIRDER PC29 GENERAL VIEW
019	BRIDGE B14 GENERAL VIEW (SHEET 1 OF 2)	050	— DO — P.C. CABLE AND REINF. BAR ARRANGEMENT OF MAIN BEAM
020	— DO — (SHEET 2 OF 2)	051	— DO — P.C. CABLE AND REINF. BAR ARRANGEMENT OF LATERAL JOINT
021	P.C. GIRDER PC01 GENERAL VIEW	052	— DO — REINF. BAR SCHEDULE
022	— DO — P.C. CABLE AND REINF. BAR ARRANGEMENT OF MAIN BEAM	053	P.C. GIRDER PC33 GENERAL VIEW
023	— DO — P.C. CABLE AND REINF. BAR ARRANGEMENT OF LATERAL JOINT	054	P.C. GIRDER PC34 GENERAL VIEW
024	— DO — REINF. BAR SCHEDULE	055	P.C. GIRDER PC39 GENERAL VIEW
025	P.C. GIRDER PC02 GENERAL VIEW	056	P.C. GIRDER PC40 GENERAL VIEW
026	— DO — P.C. CABLE AND REINF. BAR ARRANGEMENT OF MAIN BEAM	057	— DO — P.C. CABLE AND REINF. BAR ARRANGEMENT OF MAIN BEAM
027	— DO — P.C. CABLE AND REINF. BAR ARRANGEMENT OF LATERAL JOINT	058	— DO — P.C. CABLE AND REINF. BAR ARRANGEMENT OF LATERAL JOINT
028	— DO — REINF. BAR SCHEDULE	059	— DO — BENDING DIAGRAM
029	P.C. GIRDER PC04 GENERAL VIEW	060	— DO — REINF. BAR SCHEDULE
030	— DO — P.C. CABLE AND REINF. BAR ARRANGEMENT OF MAIN BEAM	061	P.C. GIRDER PC41 GENERAL VIEW
031	— DO — P.C. CABLE AND REINF. BAR ARRANGEMENT OF LATERAL JOINT	062	P.C. GIRDER PC42 GENERAL VIEW (SHEET 1 OF 2)

## INDEX OF DRAWING

DWG. No.	TITLE	DWG. No.	TITLE
CS-063	P.C. GIRDER PC42 GENERAL VIEW (SHEET 2 OF 2)	CS-092-2	PIER P18 BAR ARRANGEMENT (SHEET 2 OF 2)
064	DO P.C. CABLE AND REINF. BAR ARRANGEMENT OF MAIN BEAM	093	PIER P19 GENERAL VIEW
065	DO P.C. CABLE AND REINF. BAR ARRANGEMENT OF LATERAL JOINT (SHEET 1 OF 2)	094	PIER P20 GENERAL VIEW
066	DO (SHEET 2 OF 2)	095	PIER P20 BAR ARRANGEMENT (SHEET 1 OF 3)
067	DO REINF. BAR SCHEDULE	095-1	DO (SHEET 2 OF 3)
068	DETAIL OF BRIDGE BEARINGS FOR P.C. GIRDERS	095-2	DO (SHEET 3 OF 3)
069	SUPPORTING BEAM OF CATENARY POLE	096	PIER P21 GENERAL VIEW
070	P.C. GIRDER PC35 SLAB FOR APPARATUS CASE	097	PIER P22 GENERAL VIEW
071	P.C. GIRDER MATERIAL LIST (SHEET 1 OF 2)	098	PIER P24 GENERAL VIEW
072	DO (SHEET 2 OF 2)	098-1	PIER P24 BAR ARRANGEMENT (SHEET 1 OF 4)
073	PIER P01, P02 GENERAL VIEW	098-2	DO (SHEET 2 OF 4)
074	PIER P01 BAR ARRANGEMENT (SHEET 1 OF 3)	098-3	DO (SHEET 3 OF 4)
075	DO (SHEET 2 OF 3)	098-4	DO (SHEET 4 OF 4)
076	DO (SHEET 3 OF 3)	099	PIER P23, P25 GENERAL VIEW
077	PIER P04, P37 GENERAL VIEW	100	PIER P25 BAR ARRANGEMENT (SHEET 1 OF 2)
078	PIER P05 GENERAL VIEW	101	DO (SHEET 2 OF 2)
079	PIER P06, P07 GENERAL VIEW	102	PIER P26 GENERAL VIEW
080	PIER P06 BAR ARRANGEMENT (SHEET 1 OF 3)	103	PIER P27~P29, P38, P39 GENERAL VIEW
081	DO (SHEET 2 OF 3)	104	PIER P27 BAR ARRANGEMENT (SHEET 1 OF 2)
082	DO (SHEET 3 OF 3)	105	DO (SHEET 2 OF 2)
083	PIER P08, P09 GENERAL VIEW	106	PIER P03, P30, P33, P34 GENERAL VIEW
084	PIER P10, P11 GENERAL VIEW	107	PIER P30 BAR ARRANGEMENT (SHEET 1 OF 3)
085	PIER P12 GENERAL VIEW	108	DO (SHEET 2 OF 3)
086	PIER P12 BAR ARRANGEMENT (SHEET 1 OF 2)	109	DO (SHEET 3 OF 3)
087	DO (SHEET 2 OF 2)	110	PIER P31, P32 GENERAL VIEW
088	PIER P13, P35 GENERAL VIEW	111	PIER P40, P41 GENERAL VIEW
089	PIER P14, P15, P36 GENERAL VIEW (SHEET 2 OF 3)	112	PIER P40 BAR ARRANGEMENT (SHEET 1 OF 3)
090	PIER P16, P43~P46 GENERAL VIEW (SHEET 3 OF 3)	113	DO (SHEET 2 OF 3)
091	PIER P17 GENERAL VIEW	114	DO (SHEET 3 OF 3)
092	PIER P18 GENERAL VIEW (SHEET 1 OF 3)	115	PIER P42 GENERAL VIEW
092-1	PIER P18 BAR ARRANGEMENT (SHEET 1 OF 2)	116	PIER P47 GENERAL VIEW

## INDEX OF DRAWING

DWG. No.	TITLE	DWG. No.	TITLE
CS-117	PIER P48 GENERAL VIEW	CS-148	U SHAPED RETAINING WALL U1 BAR ARRANGEMENT (SHEET 3 OF 3)
118	PIER P48 BAR ARRANGEMENT (SHEET 1 OF 3)	149	VIADUCT VO08, VO10, VO17, VO47, VO85 GENERAL VIEW (SHEET 1 OF 2)
119	DO (SHEET 2 OF 3)	150	DO (SHEET 2 OF 2)
120	DO (SHEET 3 OF 3)	151	VIADUCT VO47 BAR ARRANGEMENT (SHEET 1 OF 7)
121	PIER P49 GENERAL VIEW	152	DO (SHEET 2 OF 7)
122	PIER P49 BAR ARRANGEMENT (SHEET 1 OF 3)	153	DO (SHEET 3 OF 7)
123	DO (SHEET 2 OF 3)	154	DO (SHEET 4 OF 7)
124	DO (SHEET 3 OF 3)	155	DO (SHEET 5 OF 7)
125	PIER P50 GENERAL VIEW	156	DO (SHEET 6 OF 7)
126	PIER P51 GENERAL VIEW	157	DO (SHEET 7 OF 7)
127	PIER P51 BAR ARRANGEMENT (SHEET 1 OF 3)	158	VIADUCT VO02, VO03, VO24~VO26, VO48, VO49, VO80~VO84, VO99, V100, V121, V122 GENERAL VIEW (SHEET 1 OF 2)
128	DO (SHEET 2 OF 3)	159	DO (SHEET 2 OF 2)
129	DO (SHEET 3 OF 3)	160	VIADUCT VO48 BAR ARRANGEMENT (SHEET 1 OF 5)
130	DETAIL OF BEARING BASE (SHEET 1 OF 2)	161	DO (SHEET 2 OF 5)
131	DO (SHEET 2 OF 2)	162	DO (SHEET 3 OF 5)
132	ABUTMENT Ab01, Ab02 GENERAL VIEW	163	DO (SHEET 4 OF 5)
133	ABUTMENT Ab02 BAR ARRANGEMENT (SHEET 1 OF 3)	164	DO (SHEET 5 OF 5)
134	DO (SHEET 2 OF 3)	165	VIADUCT VO01, VO27, VO98, V101 GENERAL VIEW (SHEET 1 OF 2)
135	DO (SHEET 3 OF 3)	166	DO (SHEET 2 OF 2)
136	ABUTMENT Ab03 GENERAL VIEW	167	VIADUCT VO11, VO13, VO14, V111, V112 GENERAL VIEW (SHEET 1 OF 2)
137	ABUTMENT Ab04 GENERAL VIEW	168	DO (SHEET 2 OF 2)
138	ABUTMENT Ab04 BAR ARRANGEMENT (SHEET 1 OF 3)	169	VIADUCT VO04~VO06, VO09, VO15, VO16, VO23, VO29, VO30, VO37~VO45, VO50~VO70, V123~V125 GENERAL VIEW (SHEET 1 OF 3)
139	DO (SHEET 2 OF 3)	170	DO (SHEET 2 OF 3)
140	DO (SHEET 3 OF 3)	171	DO (SHEET 3 OF 3)
141	ABUTMENT Ab05 GENERAL VIEW	172	VIADUCT VO12, VO19~VO22, VO31~VO36, VO71, VO72, VO75~VO79, V126 GENERAL VIEW (SHEET 1 OF 3)
142	ABUTMENT Ab05 BAR ARRANGEMENT (SHEET 1 OF 3)	173	DO (SHEET 2 OF 3)
143	DO (SHEET 2 OF 3)	174	DO (SHEET 3 OF 3)
144	DO (SHEET 3 OF 3)	175	VIADUCT V103~V110, V113~V120 GENERAL VIEW (SHEET 1 OF 3)
145	U SHAPED RETAINING WALL U1 GENERAL VIEW	176	DO (SHEET 2 OF 3)
146	U SHAPED RETAINING WALL U1 BAR ARRANGEMENT (SHEET 1 OF 3)	177	DO (SHEET 3 OF 3)
147	DO (SHEET 2 OF 3)	178	VIADUCT VO07, VO28, VO46, V102 GENERAL VIEW (SHEET 1 OF 2)

## INDEX OF DRAWING

DWG. No.	TITLE	DWG. No.	TITLE
CS-179	VIADUCT V007, V028, V046, V102 GENERAL VIEW (SHEET 2 OF 2)	CS-210	VIADUCT V095 GENERAL VIEW
180	VIADUCT V018, V073, V074 GENERAL VIEW (SHEET 1 OF 2)	211	VIADUCT V096 GENERAL VIEW (SHEET 1 OF 2)
181	— DO — (SHEET 2 OF 2)	212	— DO — (SHEET 2 OF 2)
182	VIADUCT SLAB FOR APPARATUS CASE	213	VIADUCT V097 GENERAL VIEW (SHEET 1 OF 2)
183	SUPPORTING BEAM OF CATENARY POLE (SHEET 1 OF 2)	214	— DO — (SHEET 2 OF 2)
184	— DO — (SHEET 2 OF 2)	215	R.C. GIRDER RC16 GENERAL VIEW
185	R.C. GIRDER RC01~RC04, RC08~RC15, RC27~RC29, RC33, RC34, RC121 GENERAL VIEW (SHEET 1 OF 2)	216	R.C. GIRDER RC17~RC23 GENERAL VIEW
186	— DO — (SHEET 2 OF 2)	217	R.C. GIRDER RC17 BAR ARRANGEMENT (SHEET 1 OF 2)
187	R.C. GIRDER RC01 BAR ARRANGEMENT (SHEET 1 OF 3)	218	— DO — (SHEET 2 OF 2)
188	— DO — (SHEET 2 OF 3)	219	R.C. GIRDER RC24 GENERAL VIEW
189	— DO — (SHEET 3 OF 3)	220	R.C. GIRDER RC25 GENERAL VIEW
190	R.C. GIRDER RC05~RC07, RC14, RC30~RC32 GENERAL VIEW (SHEET 1 OF 2)	221	R.C. GIRDER RC26 GENERAL VIEW
191	— DO — (SHEET 2 OF 2)	222	VIADUCT SLAB FOR APPARATUS CASE
192	VIADUCT V086 GENERAL VIEW	223	SUPPORTING BEAM OF CATENARY POLE (SHEET 1 OF 2)
193	VIADUCT V087 GENERAL VIEW	224	— DO — (SHEET 2 OF 2)
194	VIADUCT V088, V089 GENERAL VIEW		
195	VIADUCT V089 BAR ARRANGEMENT (SHEET 1 OF 7)		
196	— DO — (SHEET 2 OF 7)		
197	— DO — (SHEET 3 OF 7)		
198	— DO — (SHEET 4 OF 7)		
199	— DO — (SHEET 5 OF 7)		
200	— DO — (SHEET 6 OF 7)		
201	— DO — (SHEET 7 OF 7)		
202	VIADUCT V090~V094 GENERAL VIEW (SHEET 1 OF 2)		
203	— DO — (SHEET 2 OF 2)		
204	VIADUCT V094 BAR ARRANGEMENT (SHEET 1 OF 6)		
205	— DO — (SHEET 2 OF 6)		
206	— DO — (SHEET 3 OF 6)		
207	— DO — (SHEET 4 OF 6)		
208	— DO — (SHEET 5 OF 6)		
209	— DO — (SHEET 6 OF 6)		



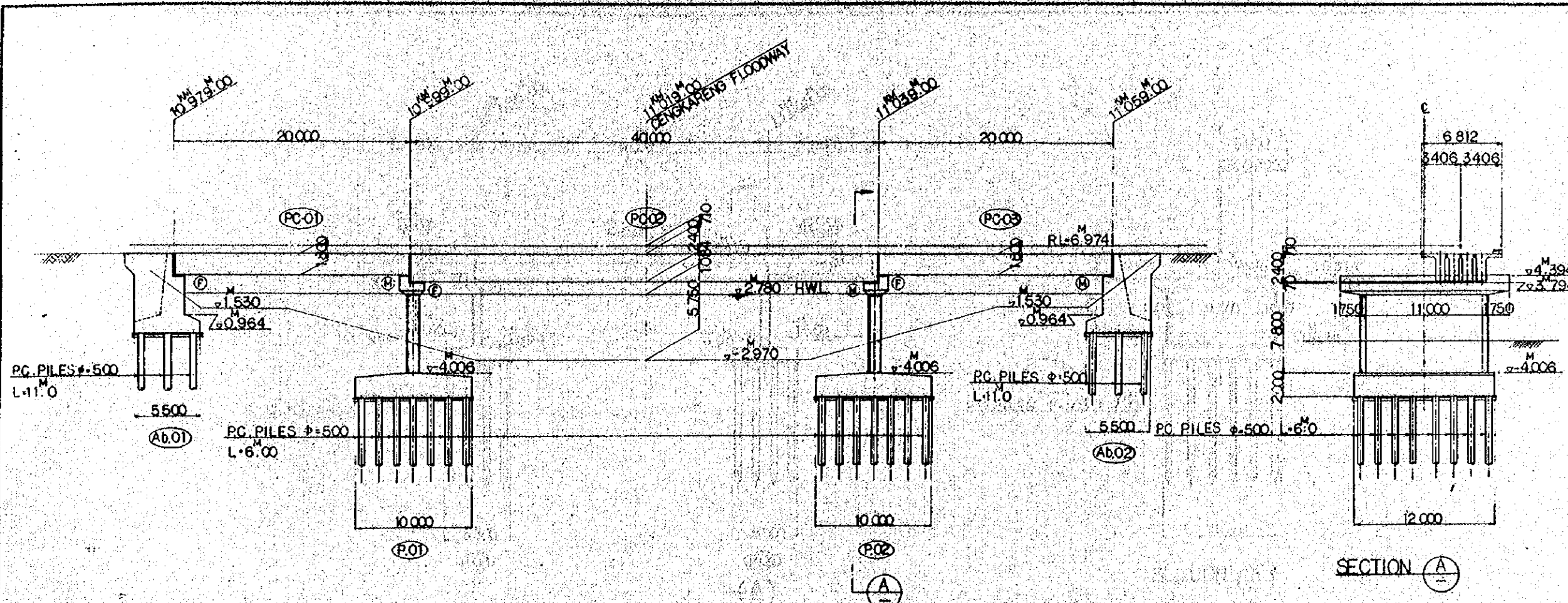

LONGITUDINAL SECTION

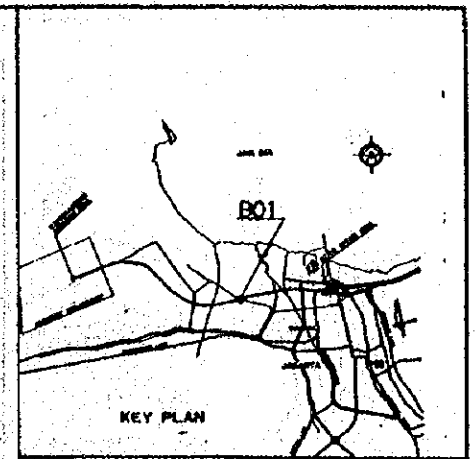

KEY PLAN

NOTES:

1. ALL DIMENSIONS ARE SHOWN IN MILLIMETERS UNLESS OTHERWISE INDICATED
2. REFERENCE DRAWING FOR GENERAL VIEW: CS-021, CS-025, CS-132, CS-073.

3. CODE:

- ⊕ --- FIXED BEARING
- ⊗ --- EXPANSION BEARING

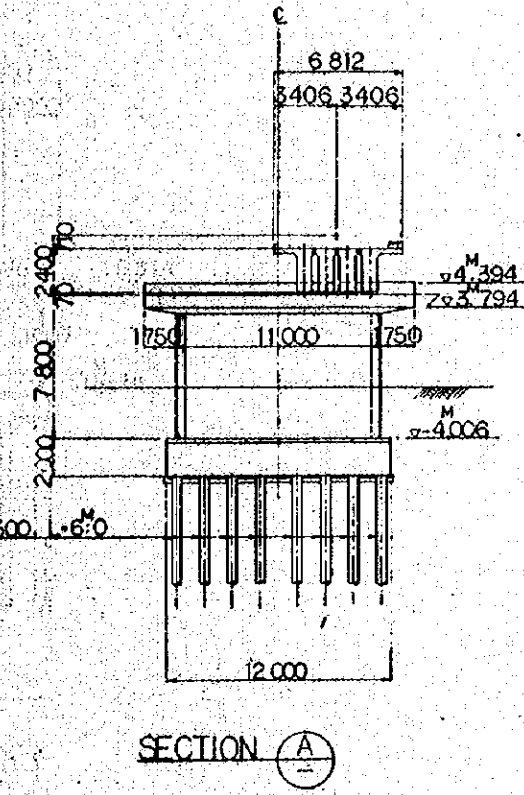

SECTION A-A

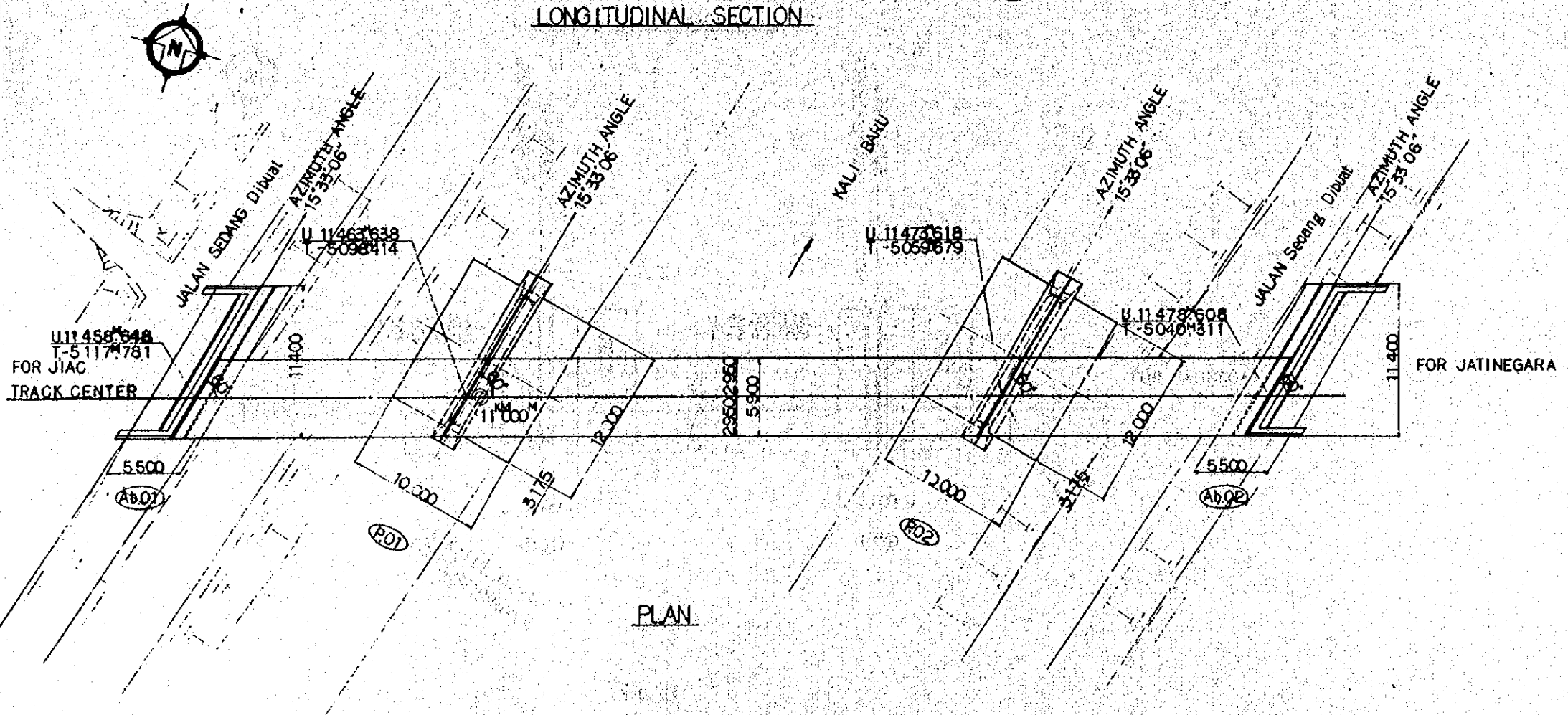

PLAN

REPUBLIC OF INDONESIA MINISTRY OF COMMUNICATIONS DIRECTORATE GENERAL OF LAND TRANSPORT AND INLAND WATERWAYS						
NEW RAILWAY LINE FOR CENKARENG AIRPORT CONSTRUCTION PROJECT						
JAPAN INTERNATIONAL COOPERATION AGENCY (JICA)						
B	1 AUG '84	M.Y.	M.Y.	K.A.	K.M.	A.K.
A	15 FEB '84	M.Y.	M.Y.	K.A.	K.M.	A.K.
REVISIONS	DATE	DESIGNED	DRAWN	CHECKED	REVIEWED	APPROVED
<b>BRIDGE B01</b> <b>GENERAL VIEW</b>						
PACKAGE: I CIVIL AND ARCHITECTURAL WORK						
SCALE: 1:200		DRAWING NO: CS-001				

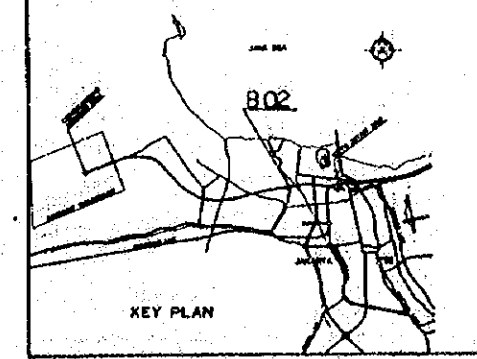
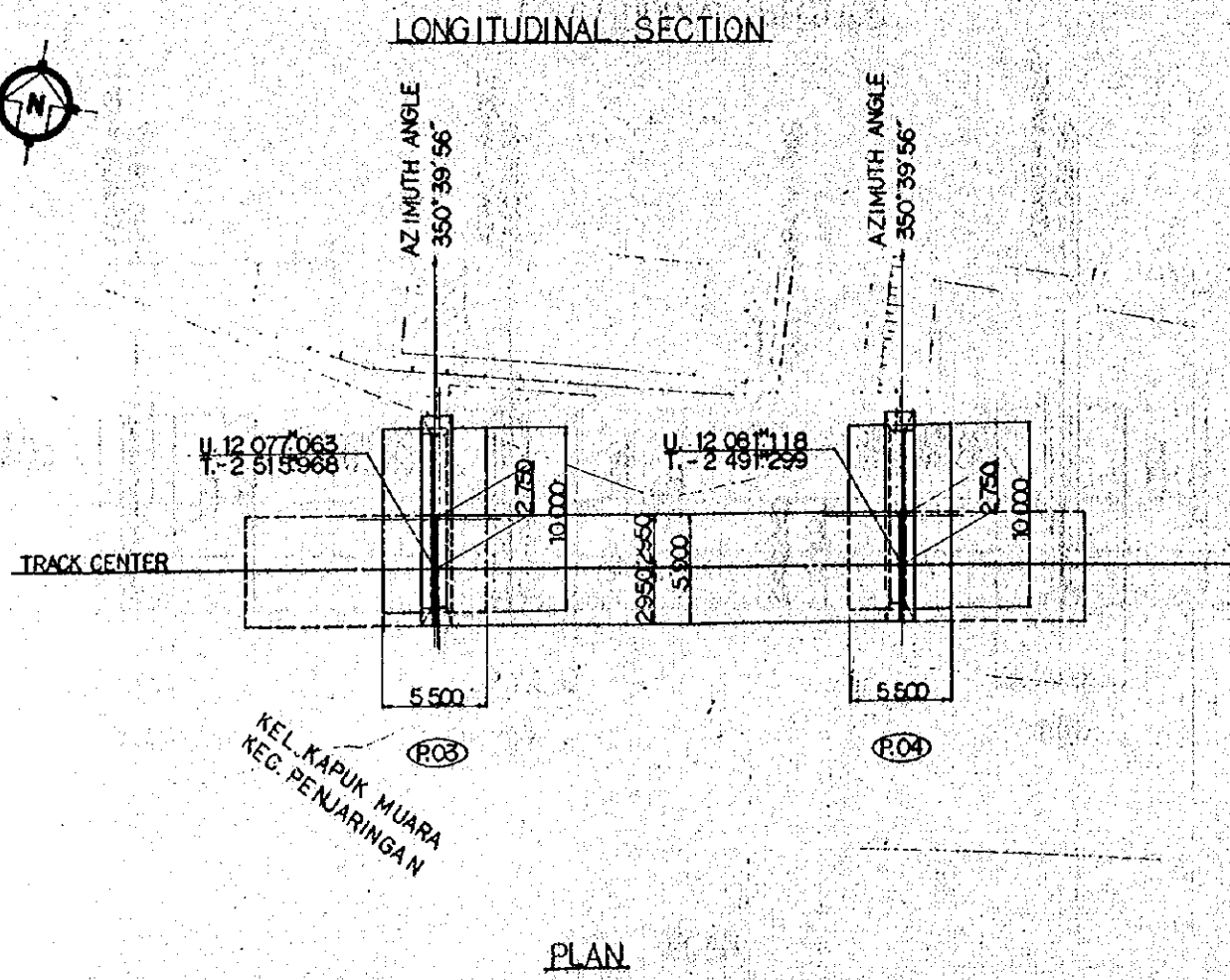
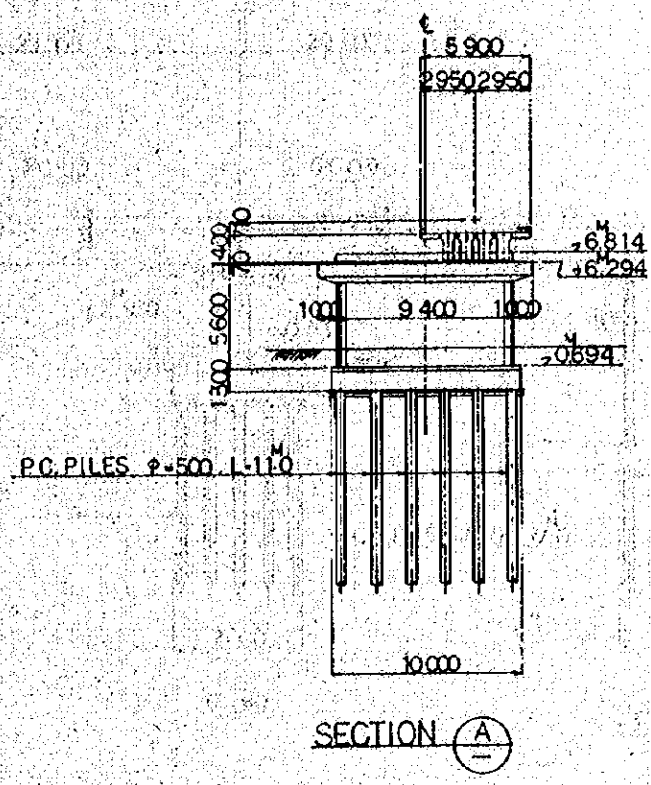
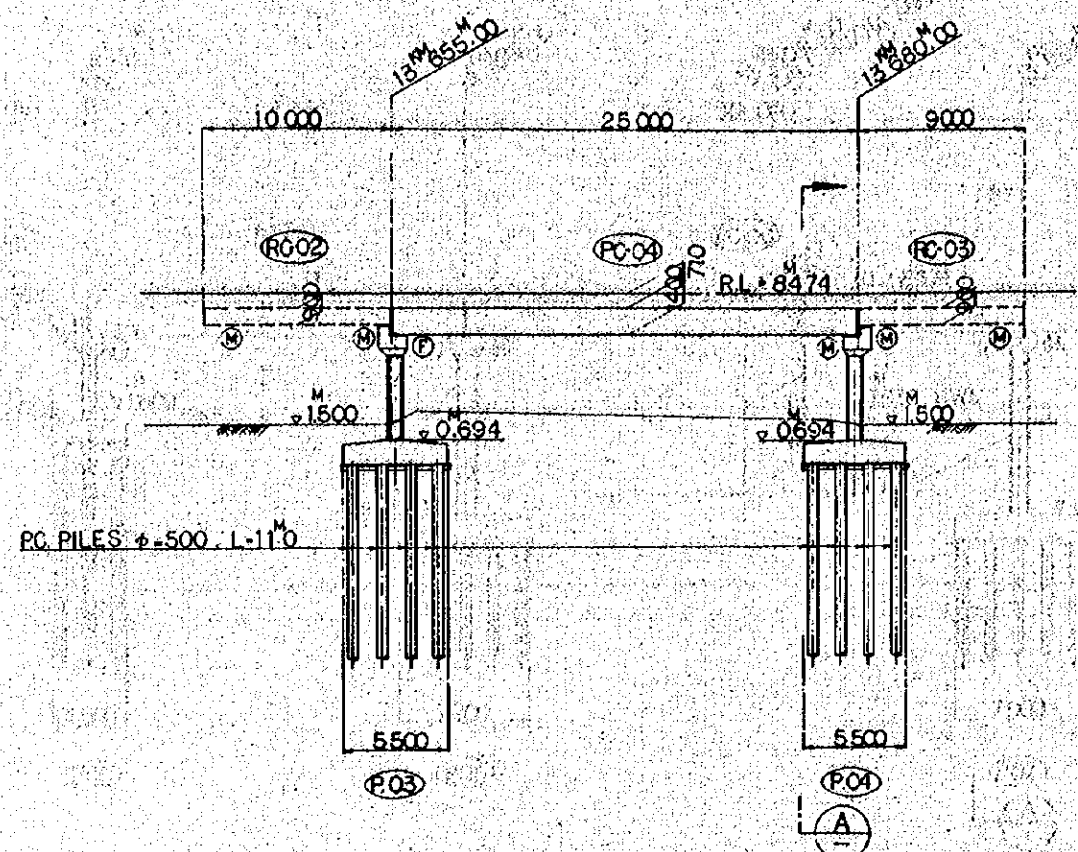

- NOTES:
1. ALL DIMENSIONS ARE SHOWN IN MILLIMETERS UNLESS OTHERWISE INDICATED
  2. REFERENCE DRAWING FOR GENERAL VIEW: CS-185,CS-029,CS-106,CS-077.
  3. CODE:
    - ⊕-----FIXED BEARING
    - ⊙-----EXPANSION BEARING

REPUBLIC OF INDONESIA						
MINISTRY OF COMMUNICATIONS						
DIRECTORATE GENERAL OF LAND TRANSPORT AND INLAND WATERWAYS						
NEW RAILWAY LINE FOR CENGKARENG AIRPORT CONSTRUCTION PROJECT						
JAPAN INTERNATIONAL COOPERATION AGENCY (JICA)						
B	1AUG'84	LLY	m.y	K.S	K.M	m.k
A	15FEB'84	M.Y	m.y	K.S	K.M	m.k
REVISIONS	DATE	DESIGNED	DRAWN	CHECKED	REVIEWED	SUBMITTED
BRIDGE B02						
GENERAL VIEW						
PACKAGE: 1 CIVIL AND ARCHITECTURAL WORK						
SCALE: 1:200		DRAWING NO: CS-002				

FOR JIAC

FOR JATINEGARA

KEL. KAPUK MUARA  
KEC. PENJARINGAN

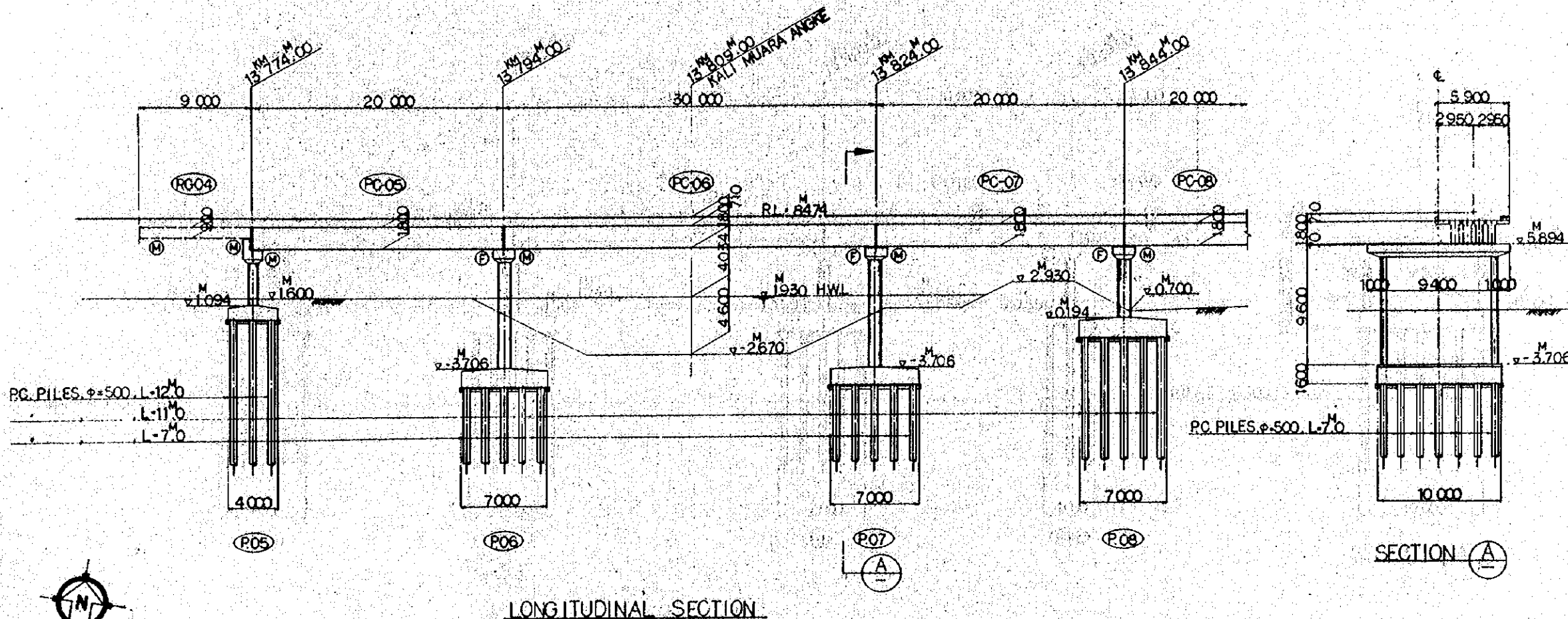

SECTION A

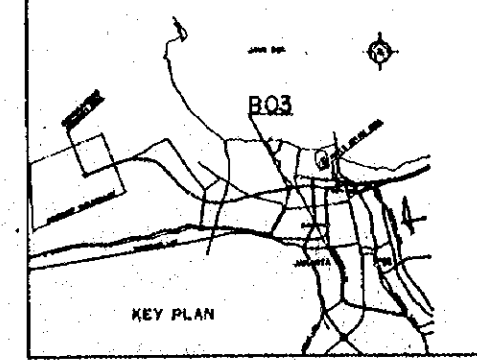

- NOTES:
1. ALL DIMENSIONS ARE SHOWN IN MILLIMETERS UNLESS OTHERWISE INDICATED
  2. REFERENCE DRAWING FOR GENERAL VIEW: CS-185, CS-033, CS-034, CS-078, CS-079, CS-083.
  3. CODE:
    - ⊕----- FIXED BEARING
    - ⊗----- EXPANSION BEARING



LONGITUDINAL SECTION

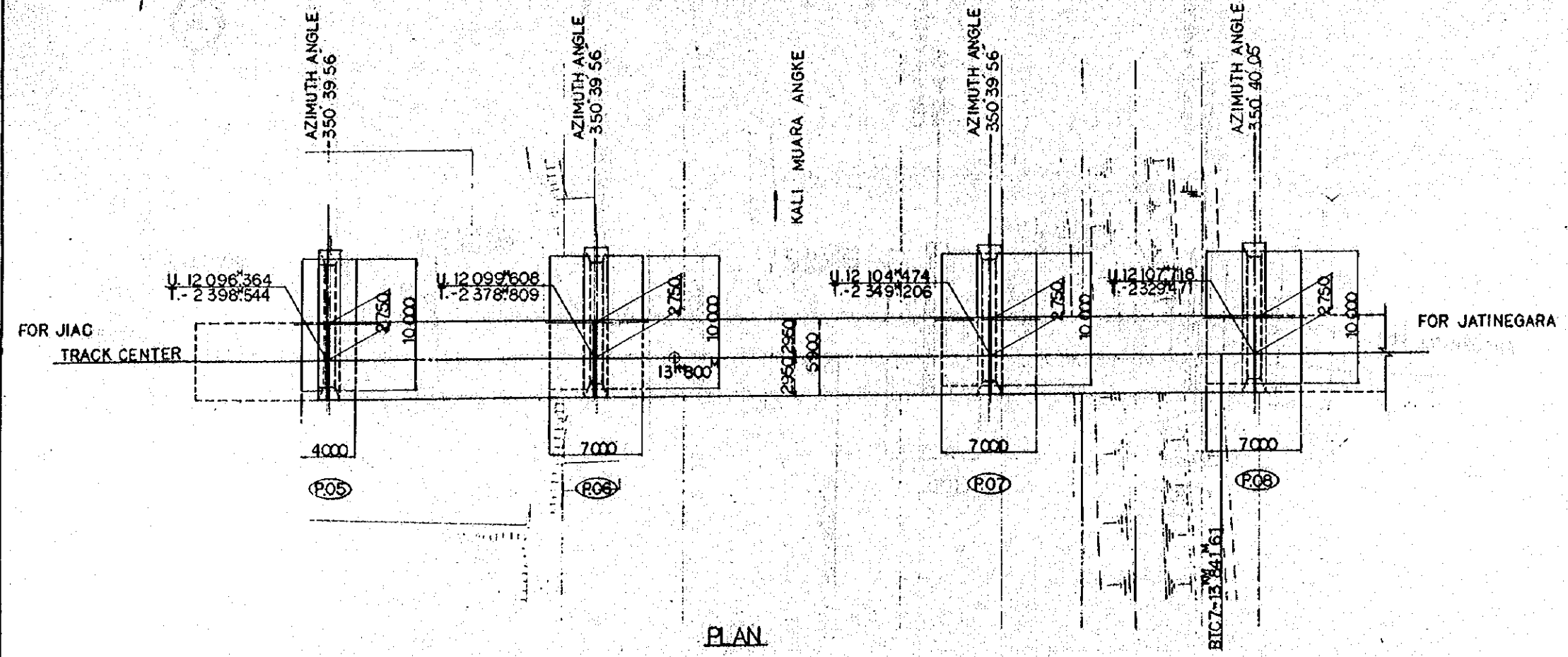

PLAN

REPUBLIC OF INDONESIA MINISTRY OF COMMUNICATIONS DIRECTORATE GENERAL OF LAND TRANSPORT AND INLAND WATERWAYS						
NEW RAILWAY LINE FOR CENGKARENG AIRPORT CONSTRUCTION PROJECT						
JAPAN INTERNATIONAL COOPERATION AGENCY (JICA)						
B	1 AUG '84	NY	m-y	KA	UM	me
A	15 FEB '84	NY	n-y	KA	UM	me
REVISOR	DATE	DESIGNED	DRAWN	CHECKED	REVIEWED	SUBMITTED
BRIDGE B03 GENERAL VIEW (SHEET 1 OF 2)						
PACKAGE: I CIVIL AND ARCHITECTURAL WORK						
SCALE: 1:200		DRAWING NO: CS-003				

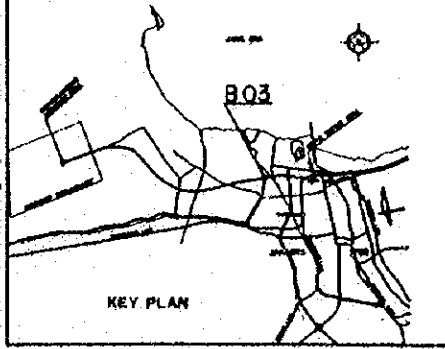
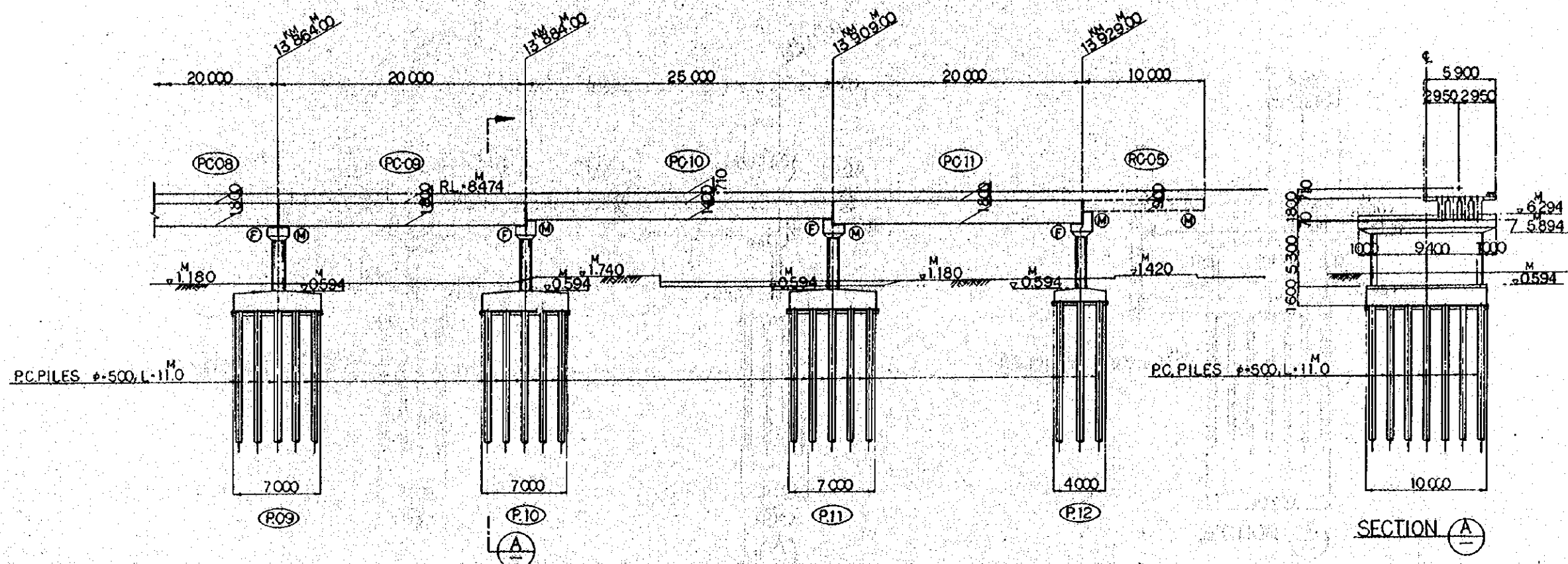

- NOTES:
- ALL DIMENSIONS ARE SHOWN IN MILLIMETERS UNLESS OTHERWISE INDICATED
  - REFERENCE DRAWING FOR GENERAL VIEW: CS-033, CS-029, CS-190, CS-083, CS-084, CS-085
  - CODE:
    - ⊕ --- FIXED BEARING
    - ⊙ --- EXPANSION BEARING

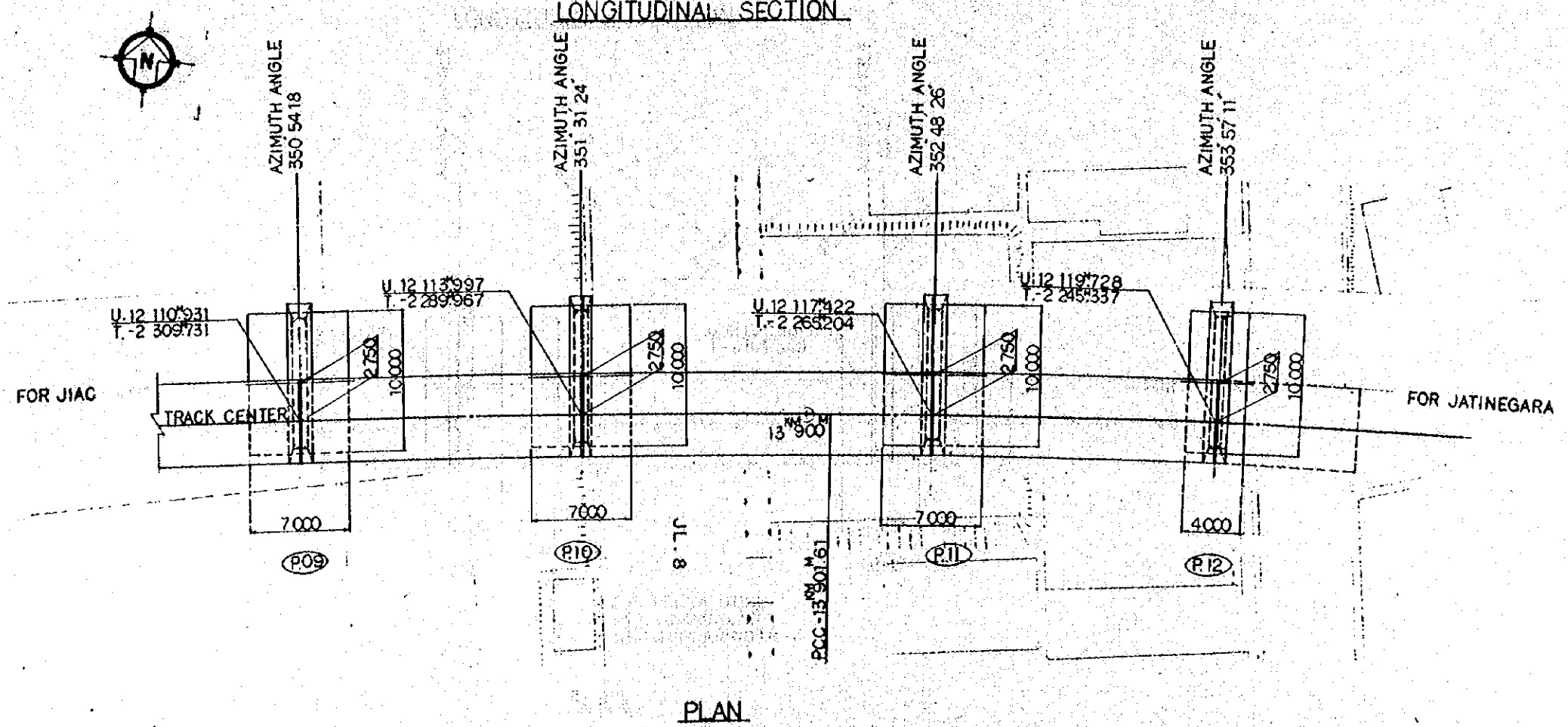

REPUBLIC OF INDONESIA MINISTRY OF COMMUNICATIONS DIRECTORATE GENERAL OF LAND TRANSPORT AND INLAND WATERWAYS						
NEW RAILWAY LINE FOR CENKARENG AIRPORT CONSTRUCTION PROJECT						
JAPAN INTERNATIONAL COOPERATION AGENCY (JICA)						
REVISIONS	DATE	DESIGNED	DRAWN	CHECKED	REVIEWED	SUBMITTED
B	1 AUG 94	MY	MY	KR	K.M	M.K
A	15 FEB 94	MY	MY	KR	K.M	M.K
BRIDGE B03 GENERAL VIEW (SHEET 2 OF 2)						
PACKAGE: I CIVIL AND ARCHITECTURAL WORK						
SCALE: 1:200		DRAWING NO: CS-004				

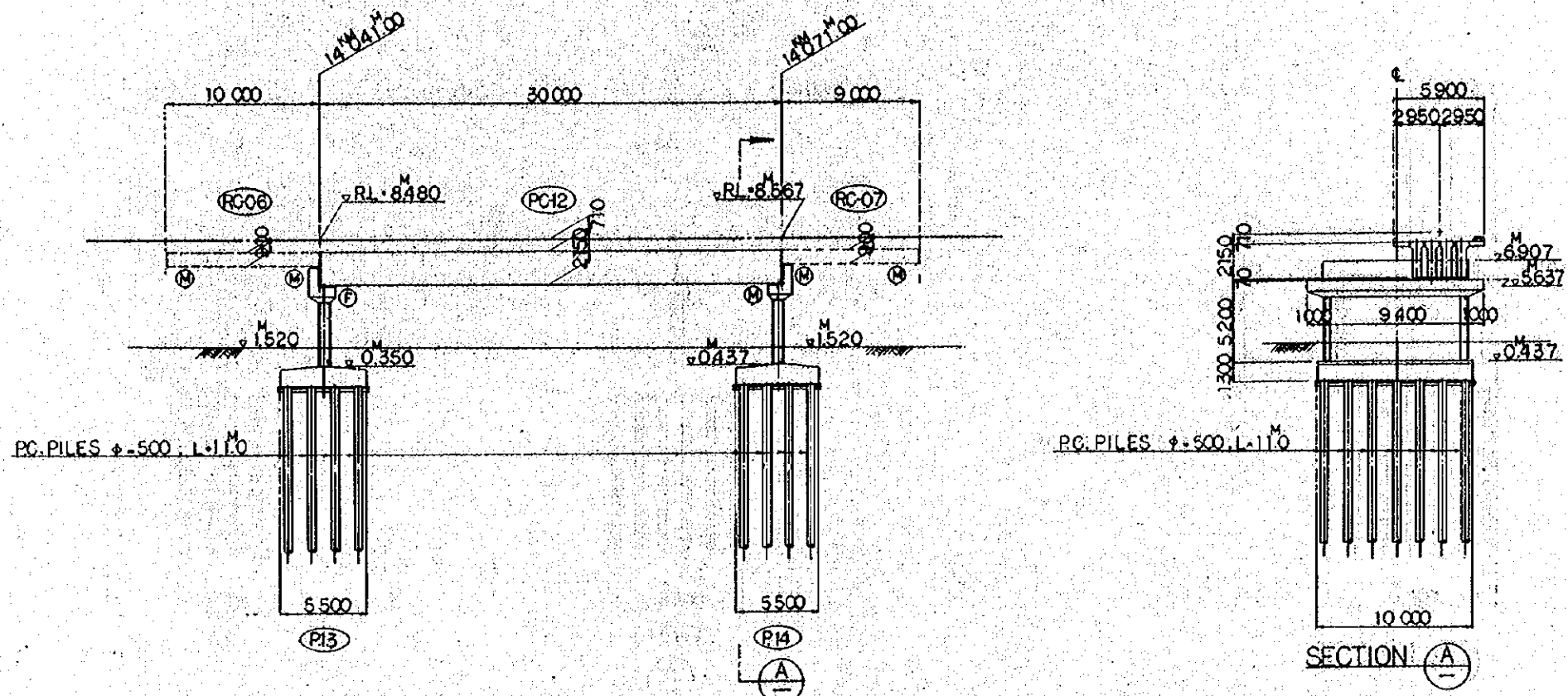

LONGITUDINAL SECTION

SECTION A

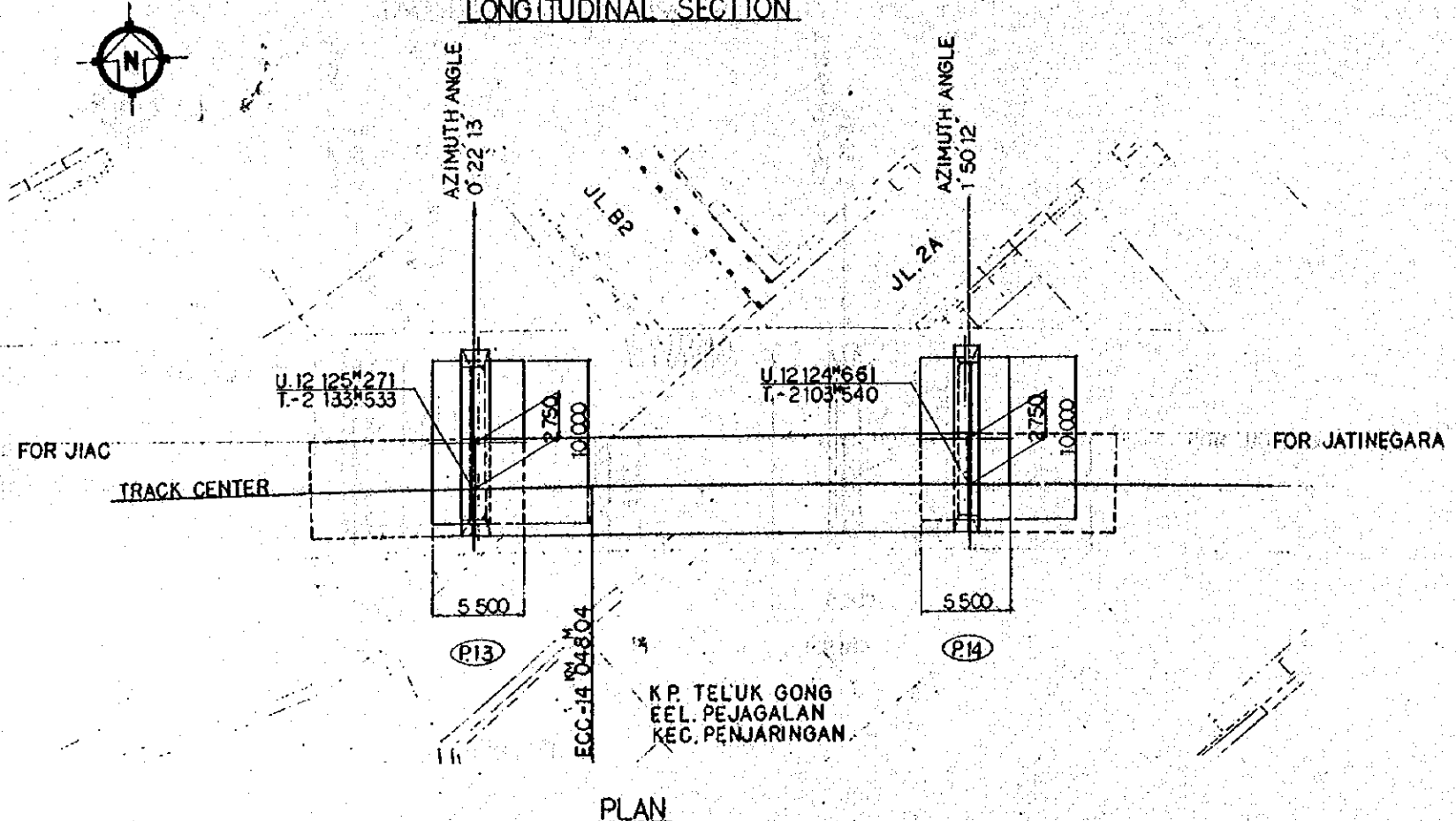

PLAN

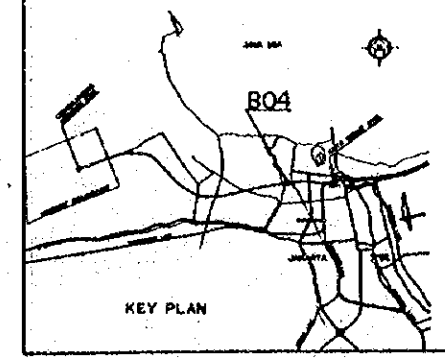

- NOTES:
1. ALL DIMENSIONS ARE SHOWN IN MILLIMETERS UNLESS OTHERWISE INDICATED
  2. REFERENCE DRAWING FOR GENERAL VIEW: CS-190, CS-038, CS-100, CS-088, CS-089
  3. CODE:
    - ⊕---FIXED BEARING
    - ⊗---EXPANSION BEARING

REPUBLIC OF INDONESIA MINISTRY OF COMMUNICATIONS DIRECTORATE GENERAL OF LAND TRANSPORT AND INLAND WATERWAYS						
NEW RAILWAY LINE FOR CENGKARENG AIRPORT CONSTRUCTION PROJECT						
JAPAN INTERNATIONAL COOPERATION AGENCY (JICA)						
REVISIONS	DATE	DRAWN	CHECKED	EXTENDED	SUBMITTED	
B	1 AUG 84	Y.Y	m.y	K.A	K.M	M.K
A	15 FEB 84	Y.Y	m.y	K.A	K.M	M.K
<b>BRIDGE B04</b> <b>GENERAL VIEW</b>						
PACKAGE: I CIVIL AND ARCHITECTURAL WORK						
SCALE: 1:200		DRAWING NO: CS-005				

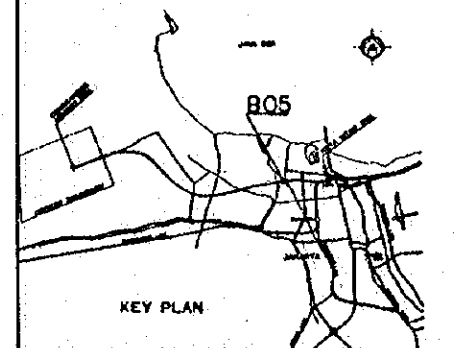
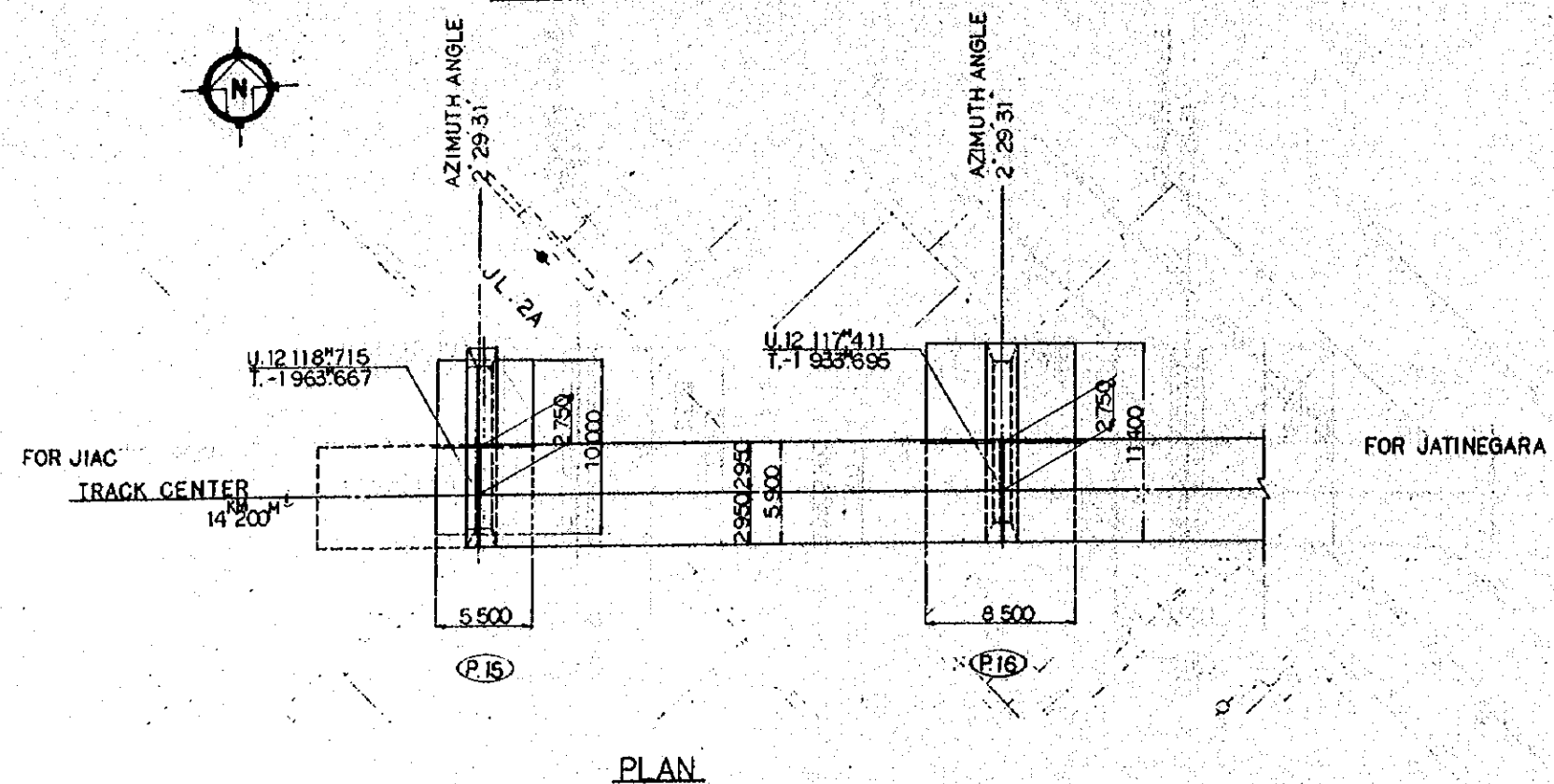
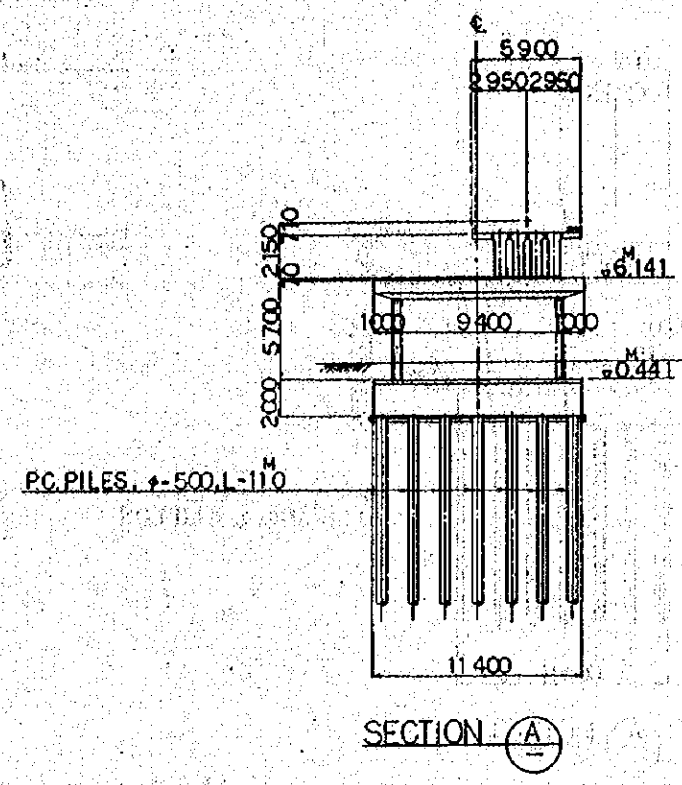
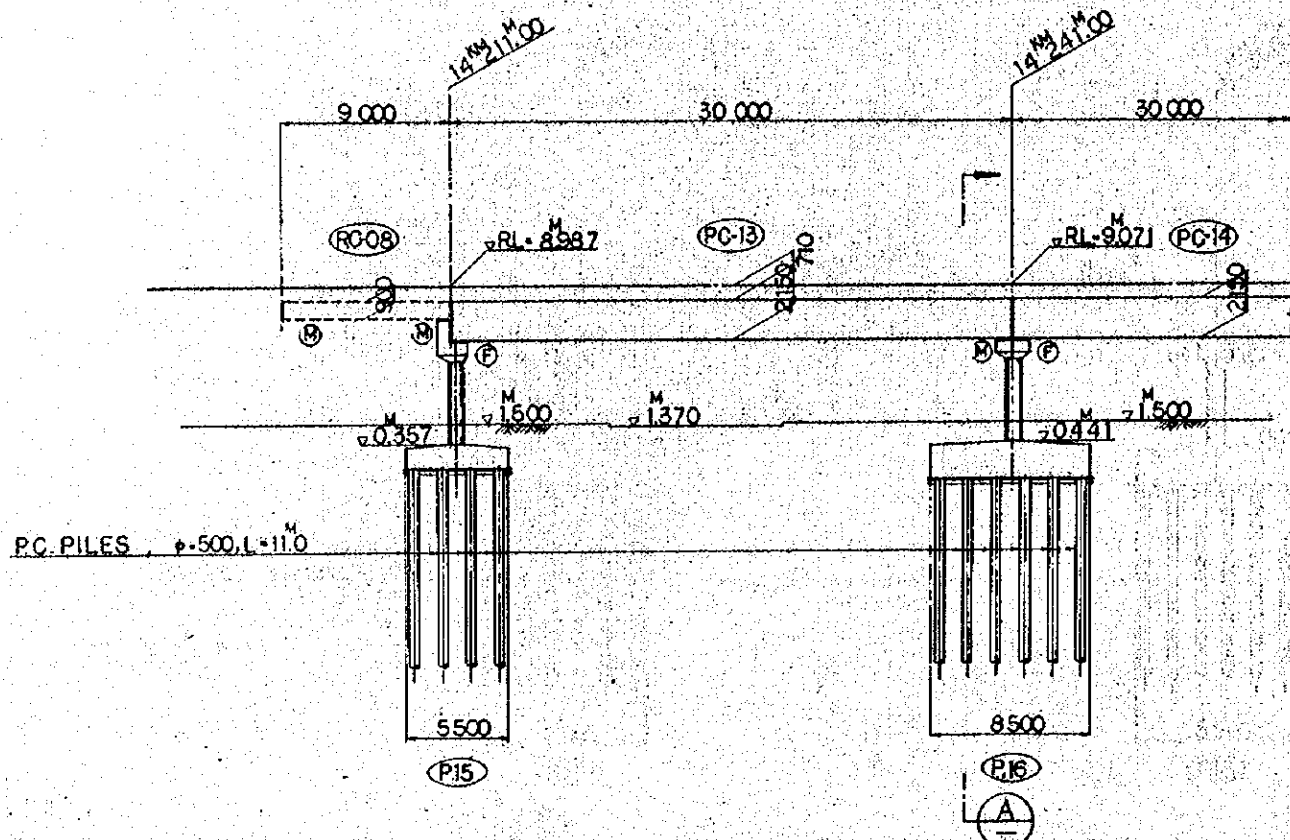

- NOTES:
1. ALL DIMENSIONS ARE SHOWN IN MILLIMETERS UNLESS OTHERWISE INDICATED
  2. REFERENCE DRAWING FOR GENERAL VIEW: CS-185, CS038, CS089, CS-090
  3. CODE:
    - ⊕---- FIXED BEARING
    - ⊗---- EXPANSION BEARING

REPUBLIC OF INDONESIA MINISTRY OF COMMUNICATIONS DIRECTORATE GENERAL OF LAND TRANSPORT AND INLAND WATERWAYS						
NEW RAILWAY LINE FOR CENKARENG AIRPORT CONSTRUCTION PROJECT						
JAPAN INTERNATIONAL COOPERATION AGENCY (JICA)						
B	1 AUG '84	M.Y.	M.Y.	K.A.	K.M.	M.M.
A	16 FEB '84	M.Y.	M.Y.	K.A.	K.M.	M.M.
REVISIONS	DATE	DESIGNED	DRAWN	CHECKED	REVIEWED	SUBMITTED
BRIDGE B05 GENERAL VIEW (SHEET 1 OF 3)						
PACKAGE: I CIVIL AND ARCHITECTURAL WORK						
SCALE	DRAWING NO.					
1:200	CS-006					

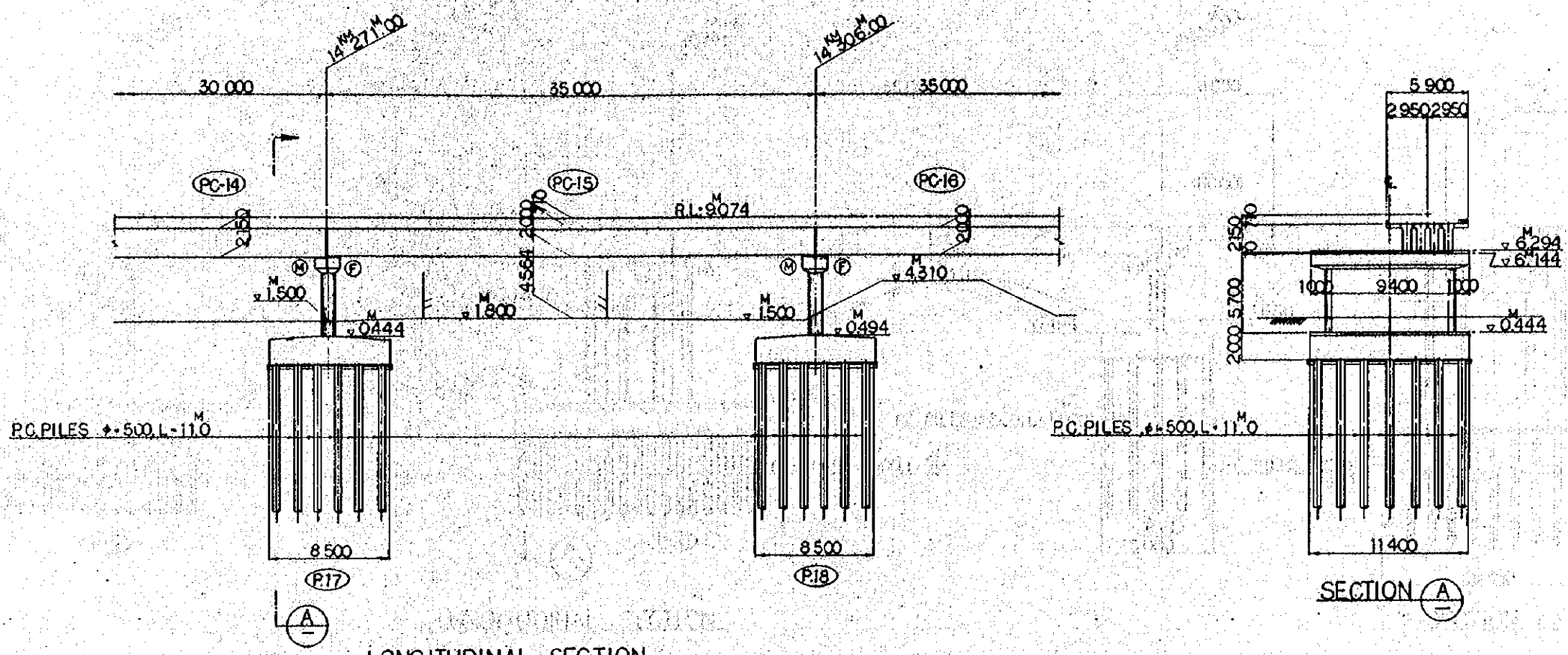

LONGITUDINAL SECTION

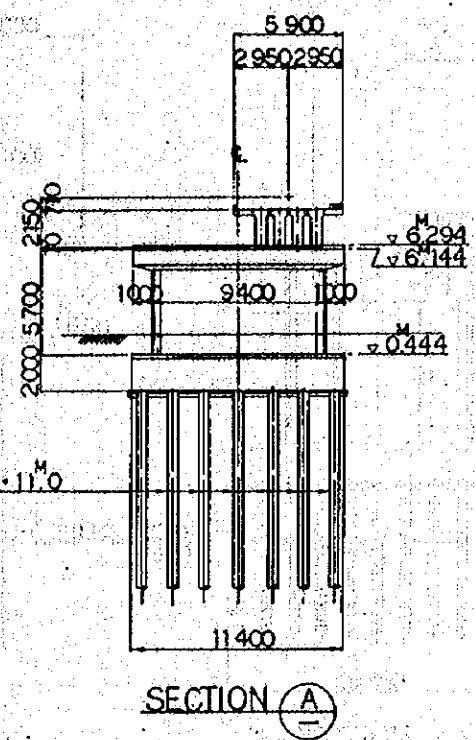

SECTION A

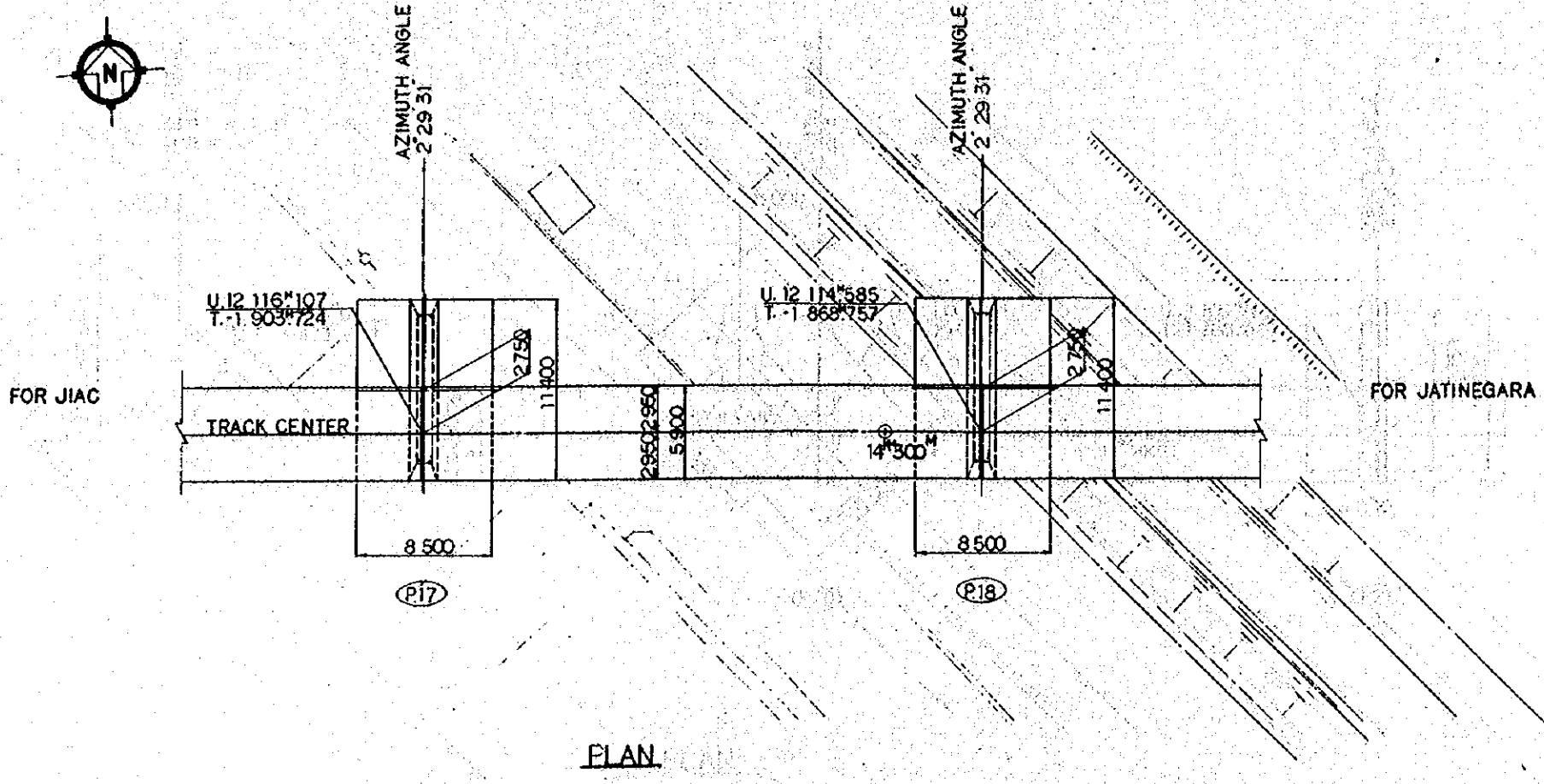

PLAN

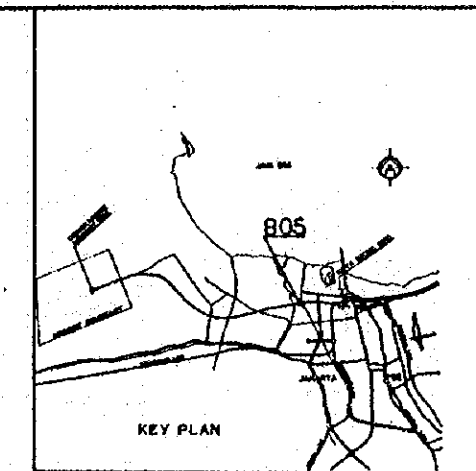

- NOTES:
1. ALL DIMENSIONS ARE SHOWN IN MILLIMETERS UNLESS OTHERWISE INDICATED
  2. REFERENCE DRAWING FOR GENERAL VIEW: CS038.CS039.CS091. CS092
  3. CODE:  
 (F) --- FIXED BEARING  
 (E) --- EXPANSION BEARING

REPUBLIC OF INDONESIA MINISTRY OF COMMUNICATIONS DIRECTORATE GENERAL OF LAND TRANSPORT AND INLAND WATERWAYS						
NEW RAILWAY LINE FOR CENGKARENG AIRPORT CONSTRUCTION PROJECT						
JAPAN INTERNATIONAL COOPERATION AGENCY (JICA)						
REVISIONS	DATE	DESIGNED	DRAWN	CHECKED	REVIEWED	SUBMITTED
B	1 AUG '84	M.Y.	M.Y.	K.A.	K.M.	M.K.
A	15 FEB '84	M.Y.	M.Y.	K.A.	K.M.	M.K.
BRIDGE B05 GENERAL VIEW (SHEET 2 OF 3)						
PACKAGE: I CIVIL AND ARCHITECTURAL WORK						
SCALE: 1:200		DRAWING NO: CS-007				

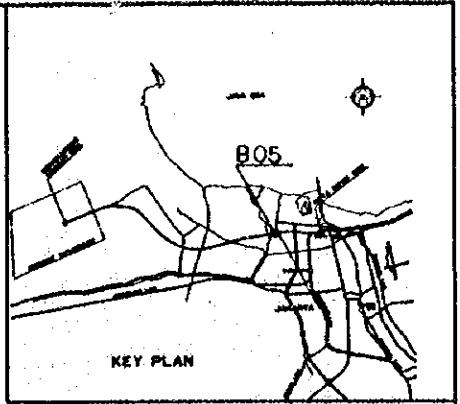
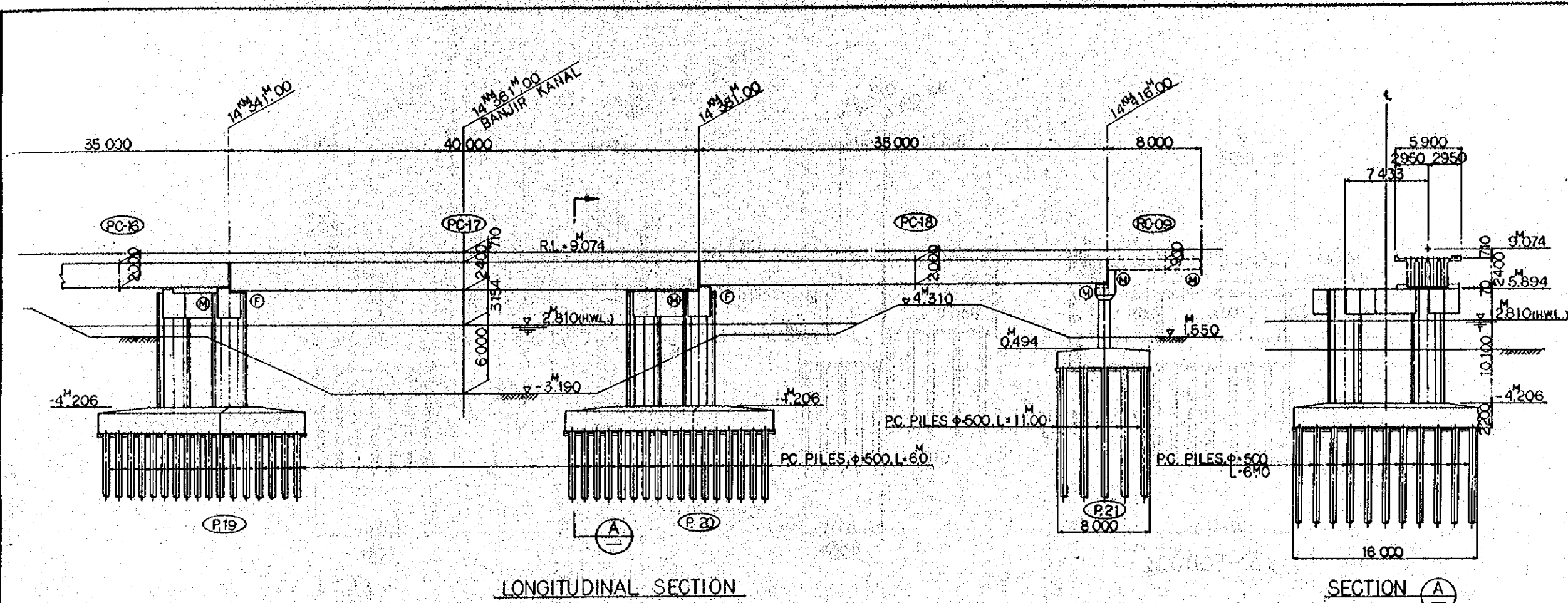

- NOTES:
- ALL DIMENSIONS ARE SHOWN IN MILLIMETERS UNLESS OTHERWISE INDICATED
  - REFERENCE DRAWING FOR GENERAL VIEW: CS-039, CS-043, CS-185, CS-093, CS-094, CS-096
  - CODE:
    - ⊕----FIXED BEARING
    - ⊗----EXPANSION BEARING

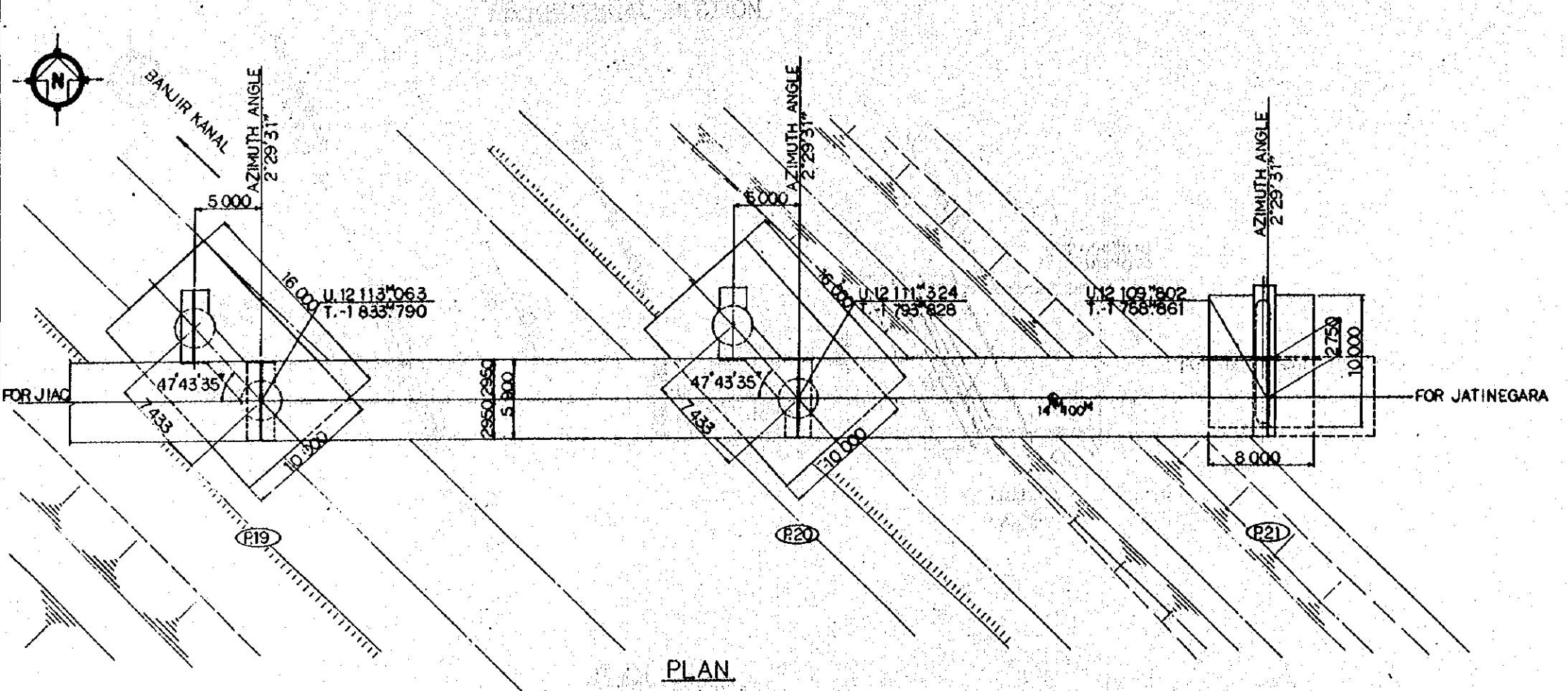

REPUBLIC OF INDONESIA MINISTRY OF COMMUNICATIONS DIRECTORATE GENERAL OF LAND TRANSPORT AND INLAND WATERWAYS					
NEW RAILWAY LINE FOR CENKARENG AIRPORT CONSTRUCTION PROJECT					
JAPAN INTERNATIONAL COOPERATION AGENCY (JICA)					
A	1 AUG. 84	DESIGNED	CHECKED	REVIEWED	SUBMITTED
REVISIONS	DATE	DESIGNED	CHECKED	REVIEWED	SUBMITTED
<b>BRIDGE 805</b> <b>GENERAL VIEW</b> <b>(SHEET 3 OF 3)</b>					
PACKAGE: 1 CIVIL AND ARCHITECTURAL WORK					
SCALE: 1:200		DRAWING NO: CS-008			



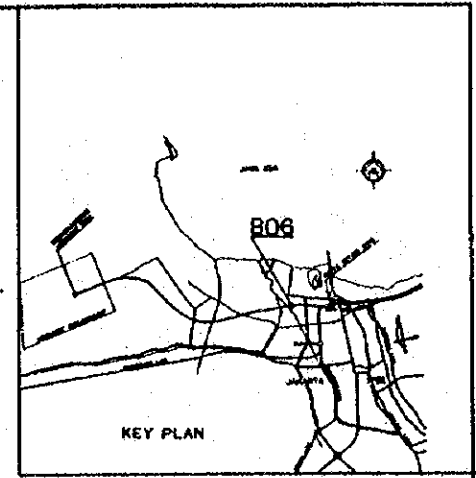

- NOTES:
1. ALL DIMENSIONS ARE SHOWN IN MILLIMETERS UNLESS OTHERWISE INDICATED
  2. REFERENCE DRAWING FOR GENERAL VIEW: CS-185, CS-025, CS-097, CS-137, CS-145.
  3. CODE :
    - ⊙ --- FIXED BEARING
    - ⊕ --- EXPANSION BEARING

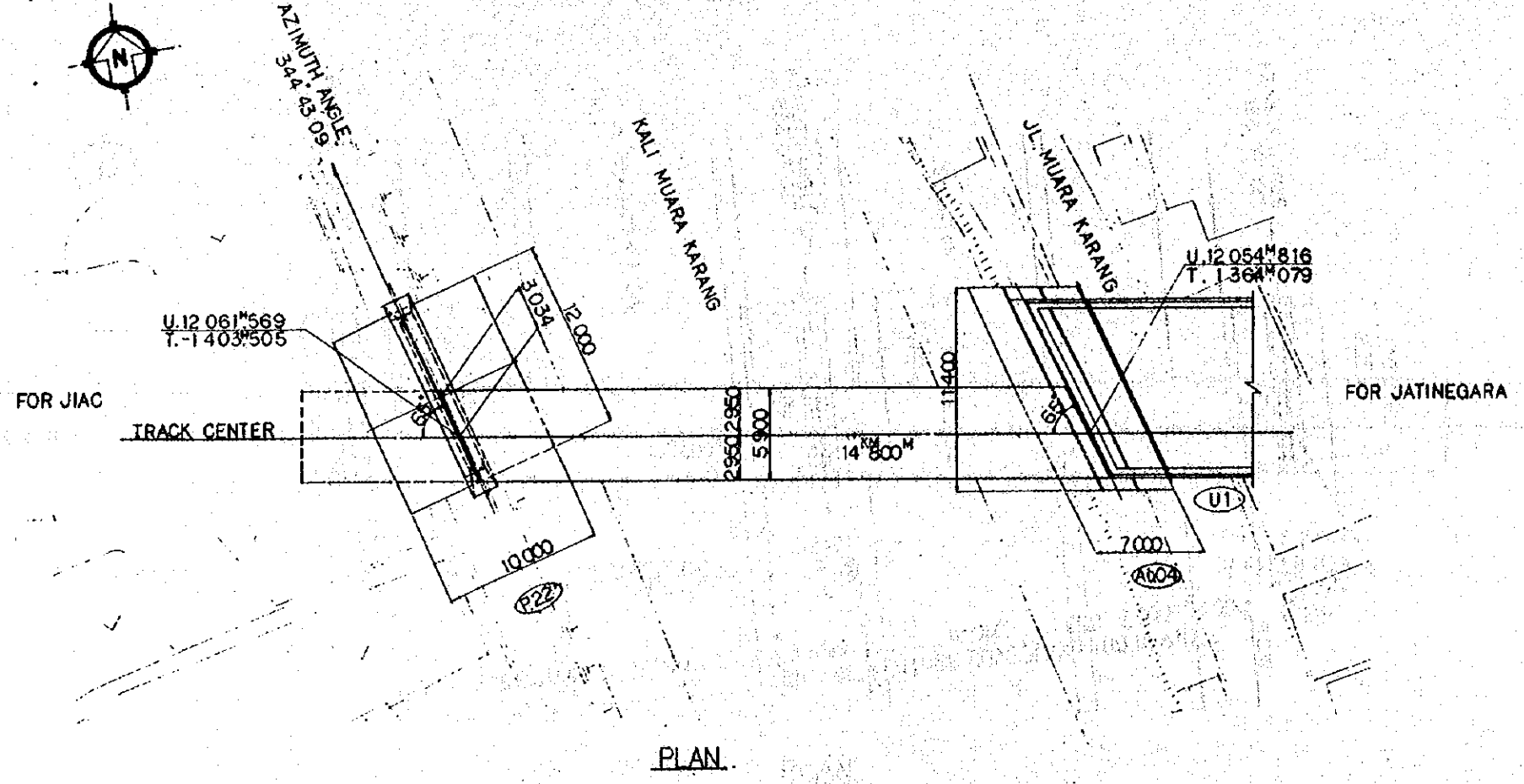
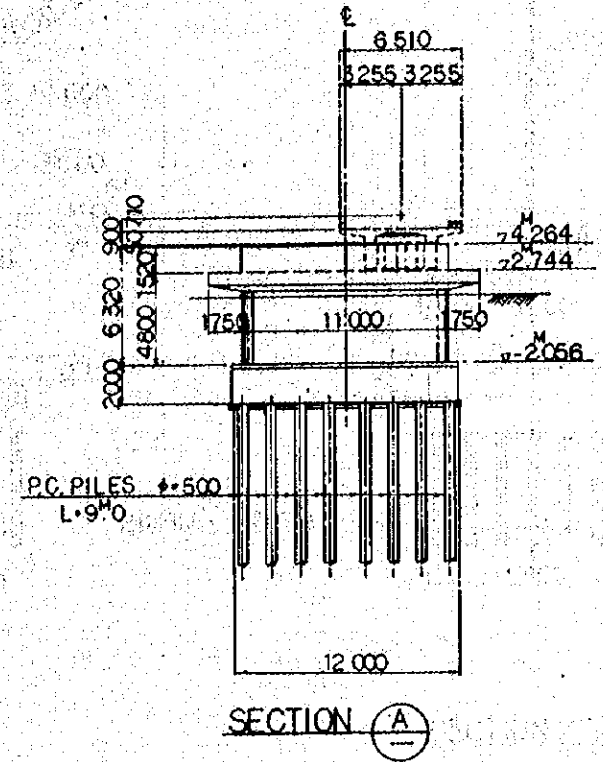
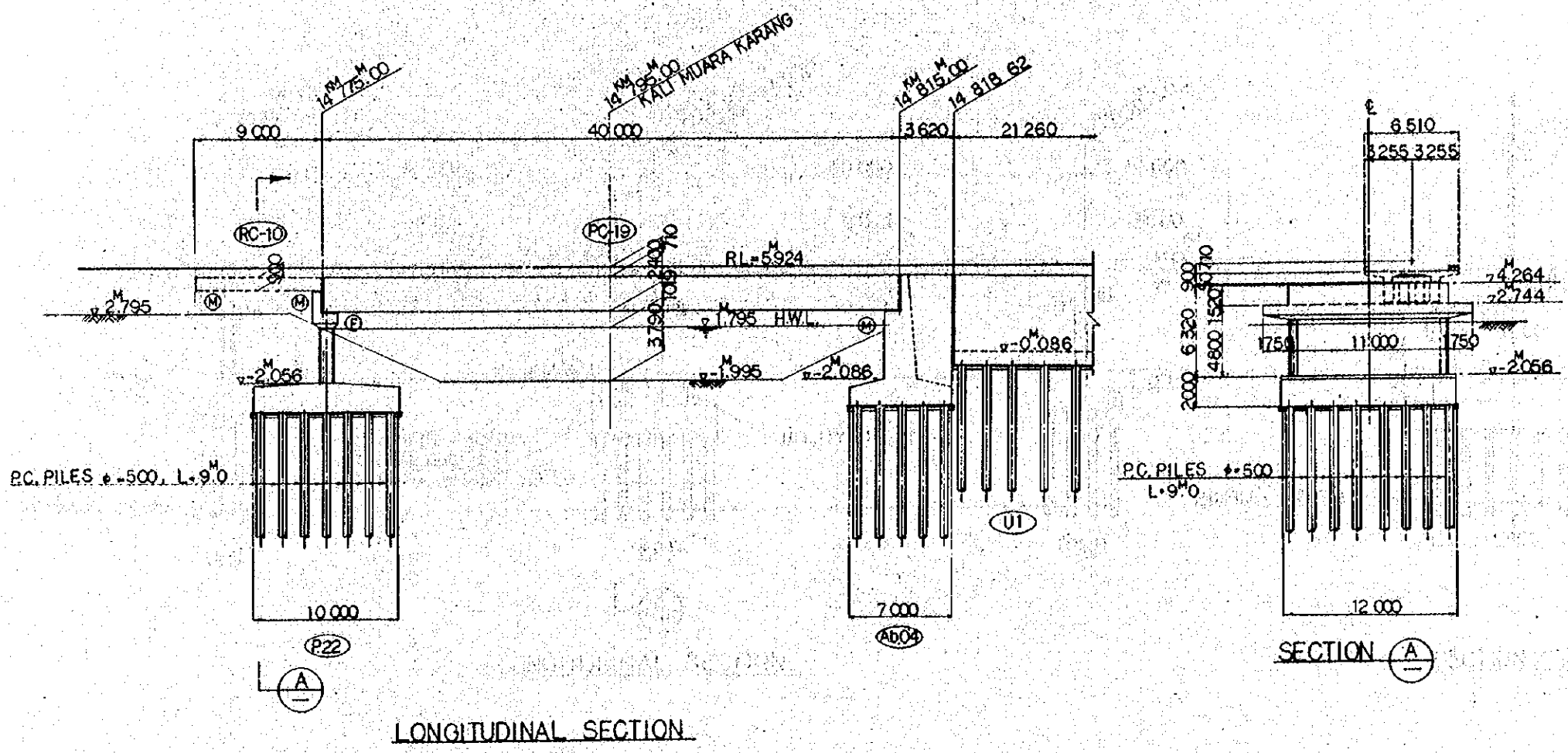

REPUBLIC OF INDONESIA MINISTRY OF COMMUNICATIONS DIRECTORATE GENERAL OF LAND TRANSPORT AND INLAND WATERWAYS						
NEW RAILWAY LINE FOR CENGKARENG AIRPORT CONSTRUCTION PROJECT						
JAPAN INTERNATIONAL COOPERATION AGENCY (JICA)						
B	1 AUG. 84	M.Y.	M.Y.	K.A.	K.M.	M.K.
A	15 FEB. 84	M.Y.	M.Y.	K.A.	K.M.	M.K.
REVISIONS	DATE	DESIGNED	CHECKED	APPROVED	REVISED	SUBMITTED
BRIDGE B06 GENERAL VIEW						
PACKAGE: I CIVIL AND ARCHITECTURAL WORK						
SCALE: 1:200		DRAWING NO: CS-009				

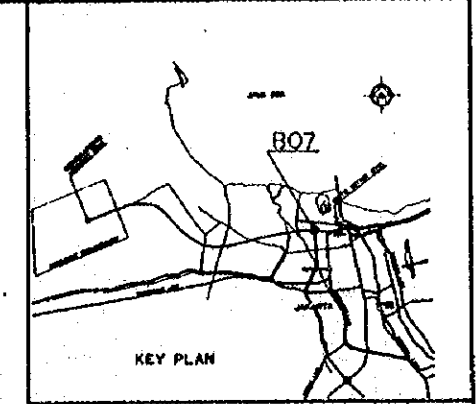
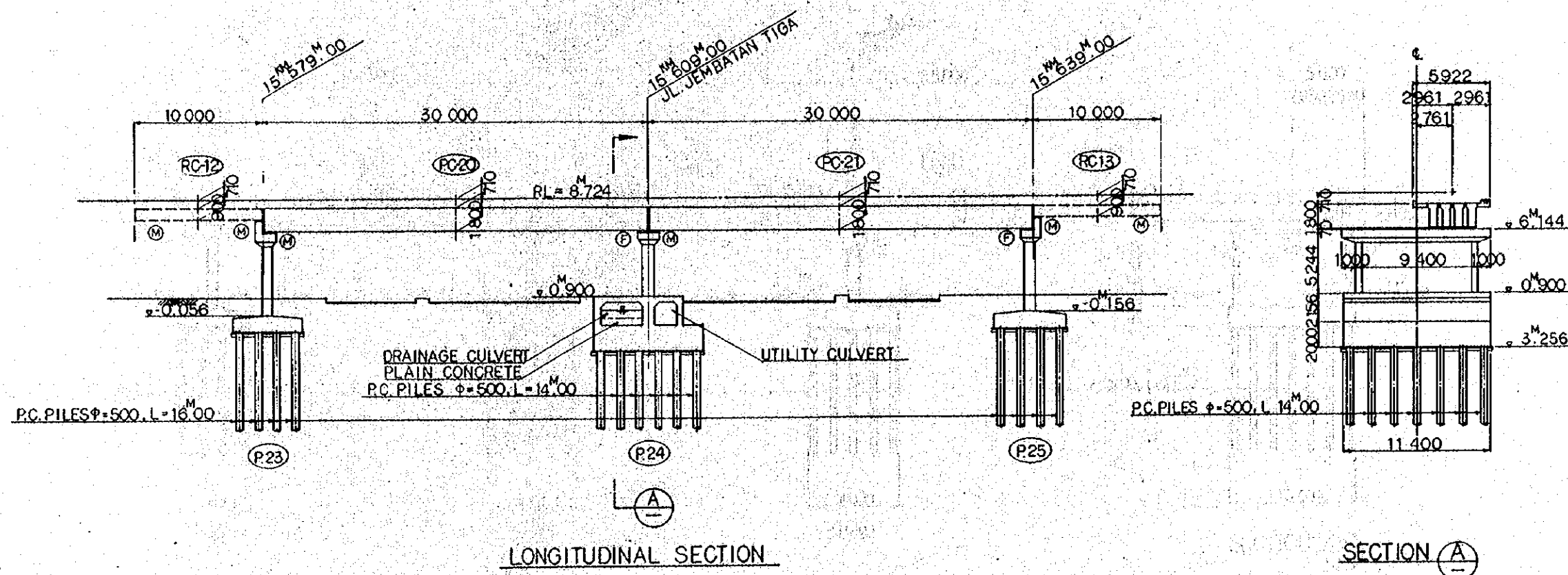

- NOTES:
1. ALL DIMENSIONS ARE SHOWN IN MILLIMETERS UNLESS OTHERWISE INDICATED.
  2. REFERENCE DRAWING FOR GENERAL VIEW: CS-185, CS-034, CS-98, CS-099.
  3. DESIGN OF DRAINAGE/UTILITY CULVERT AS SHOWN ARE SUBJECT TO MODIFICATION IN CONNECTION WITH ROAD WIDENING PLAN.
  4. CODE :  
 (F)----- FIXED BEARING  
 (M)----- EXPANSION BEARING

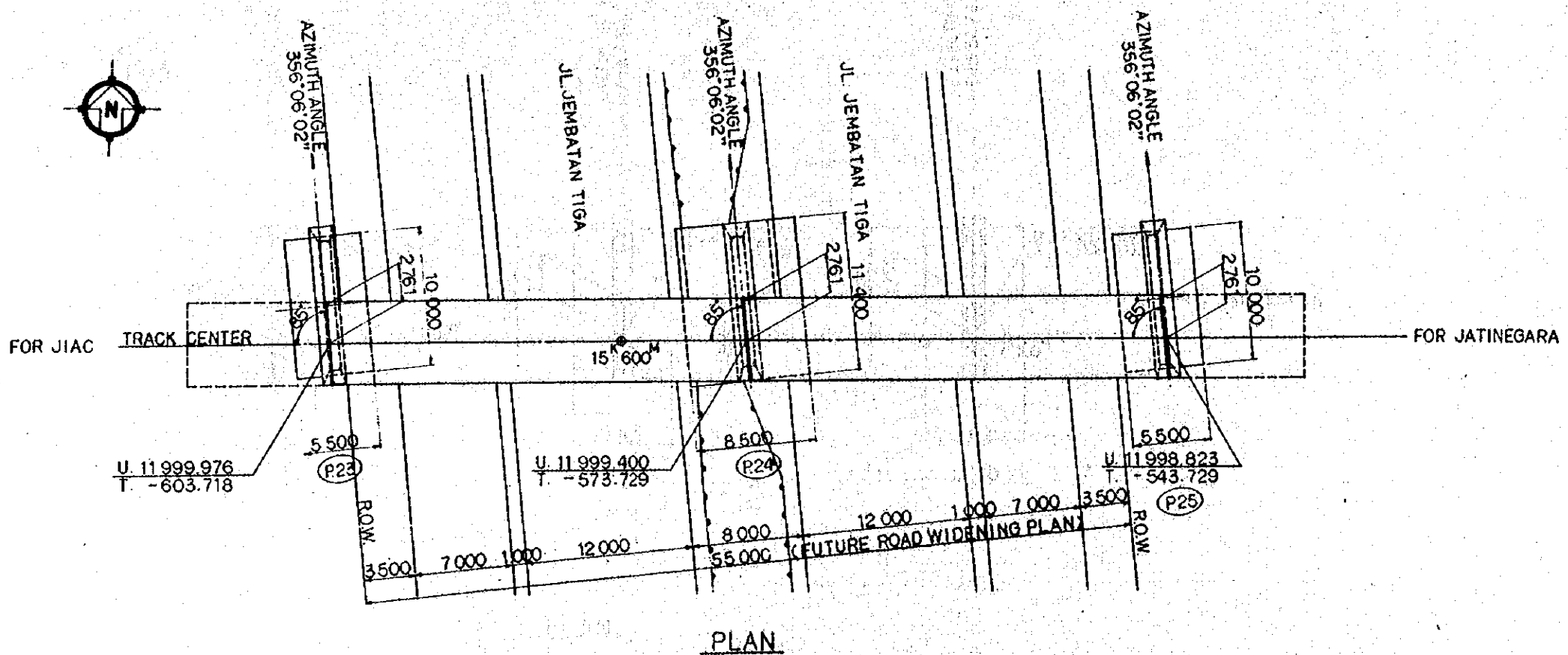

REPUBLIC OF INDONESIA MINISTRY OF COMMUNICATIONS DIRECTORATE GENERAL OF LAND TRANSPORT AND INLAND WATERWAYS						
NEW RAILWAY LINE FOR CENKARENG AIRPORT CONSTRUCTION PROJECT						
JAPAN INTERNATIONAL COOPERATION AGENCY (JICA)						
REVISIONS	DATE	DESIGNED	DRAWN	CHECKED	REVIEWED	SUBMITTED
A	1AUG'84	ny	m.y	KA	UM	rk
<b>BRIDGE B07</b> <b>GENERAL VIEW</b>						
PACKAGE: I CIVIL AND ARCHITECTURAL WORK						
SCALE: 1:200		DRAWING NO: CS-010				

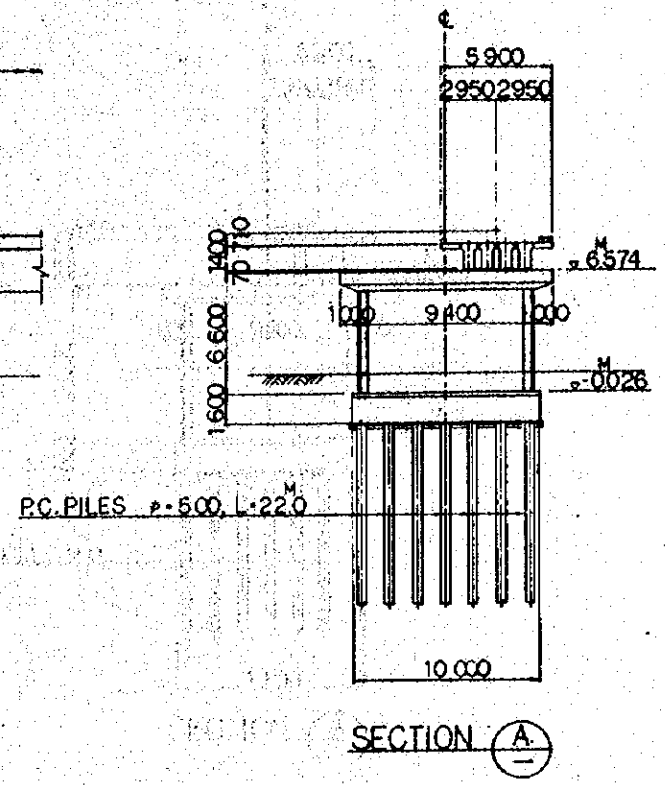
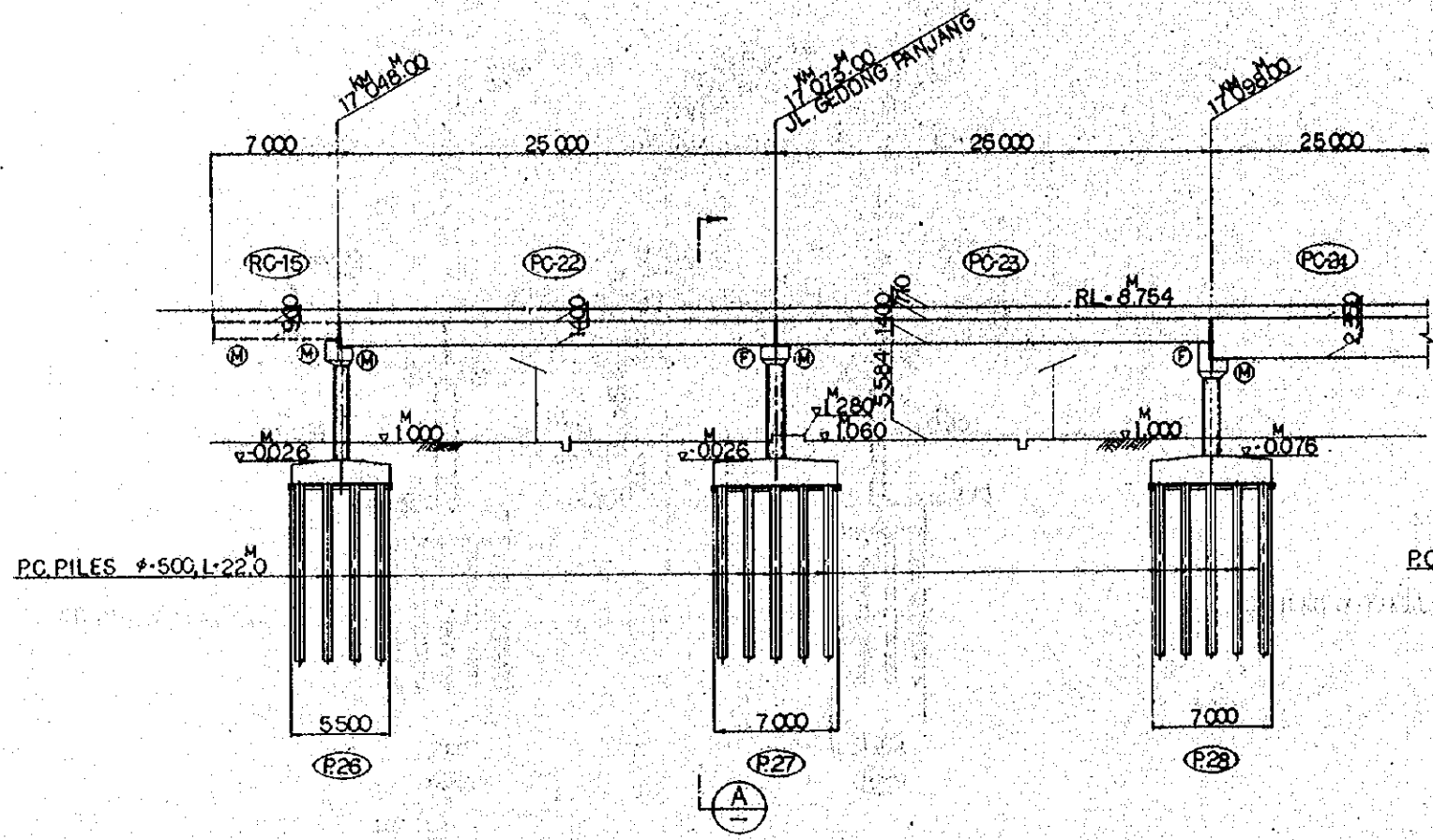

LONGITUDINAL SECTION

SECTION (A)

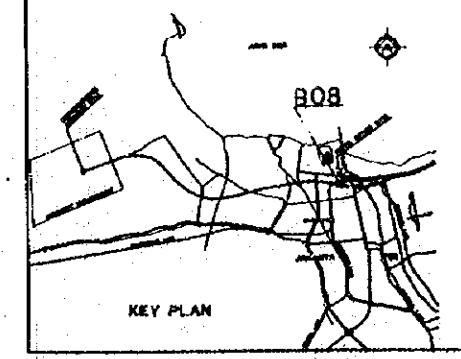

- NOTES:
- ALL DIMENSIONS ARE SHOWN IN MILLIMETERS UNLESS OTHERWISE INDICATED
  - REFERENCE DRAWING FOR GENERAL VIEW: CS185, CS029, CS044, CS102, CS103.
  - CODE:
    - ⊕---- FIXED BEARING
    - ⊙---- EXPANSION BEARING

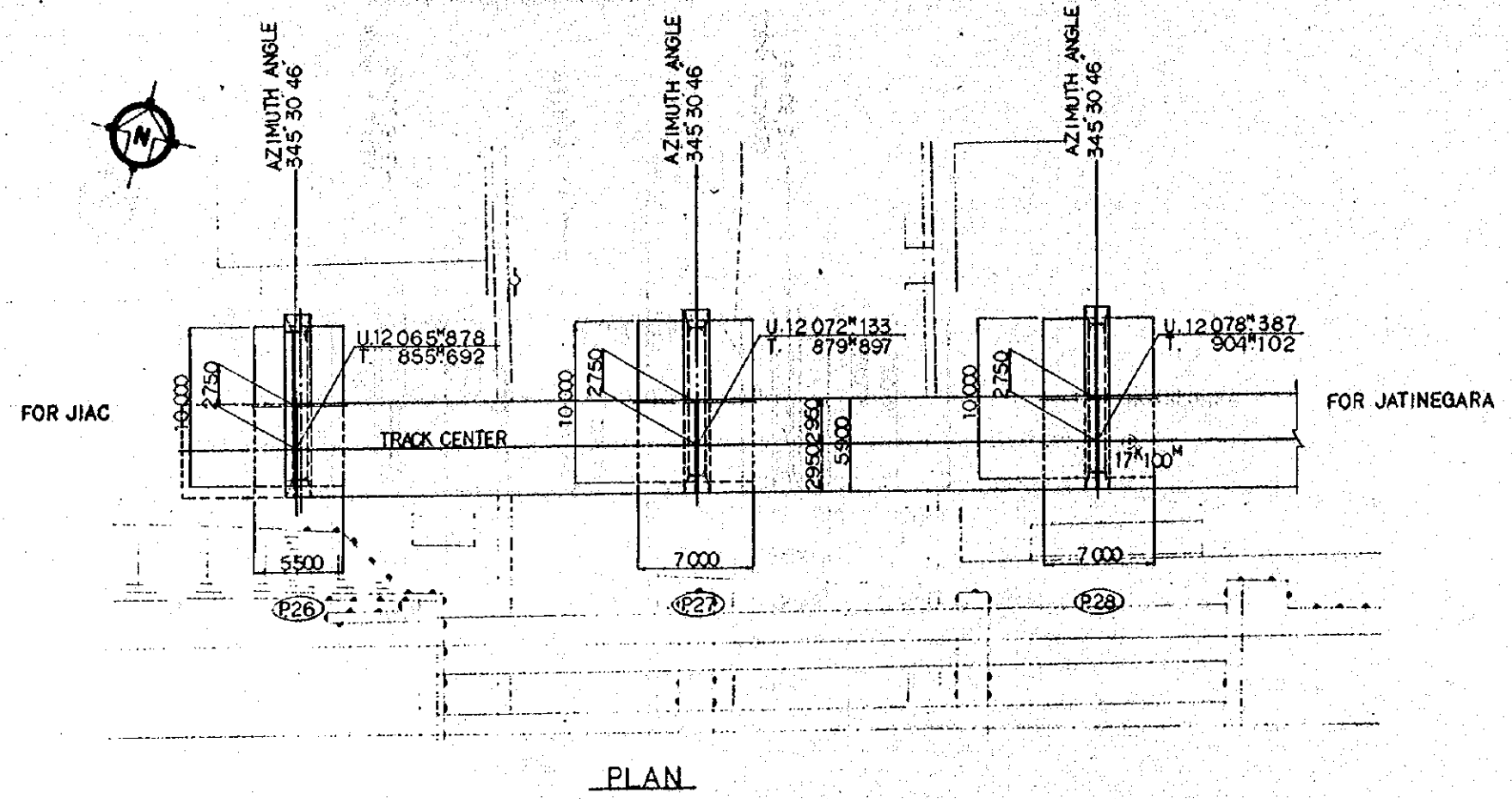

PLAN

REPUBLIC OF INDONESIA MINISTRY OF COMMUNICATIONS DIRECTORATE GENERAL OF LAND TRANSPORT AND INLAND WATERWAYS						
NEW RAILWAY LINE FOR CENGKARENG AIRPORT CONSTRUCTION PROJECT						
JAPAN INTERNATIONAL COOPERATION AGENCY (JICA)						
B	1 AUG. '84	REV.	REV.	REV.	REV.	REV.
A	15 FEB. '84	REV.	REV.	REV.	REV.	REV.
REVISIONS	DATE	DESIGNED	DRAWN	CHECKED	REVIEWED	SUBMITTED
BRIDGE B08 GENERAL VIEW (SHEET 1 OF 2)						
PACKAGE: I CIVIL AND ARCHITECTURAL WORK						
SCALE: 1:200		DRAWING NO: CS-011				

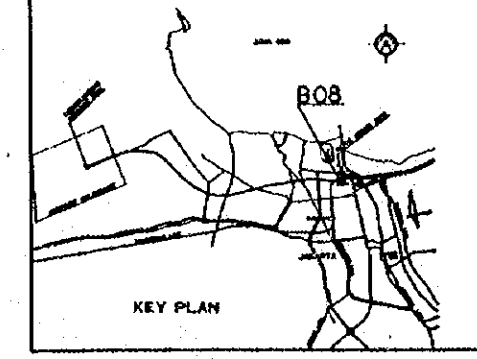
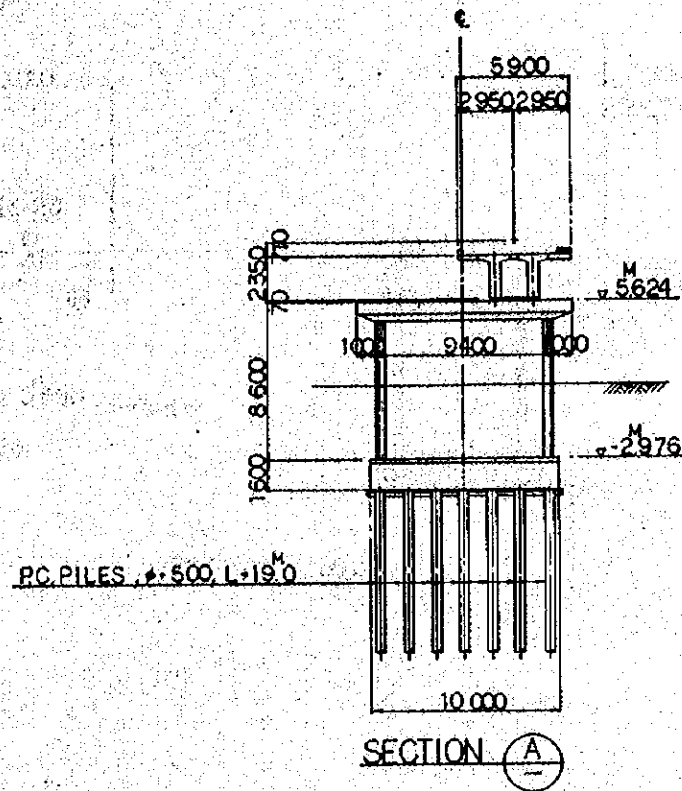
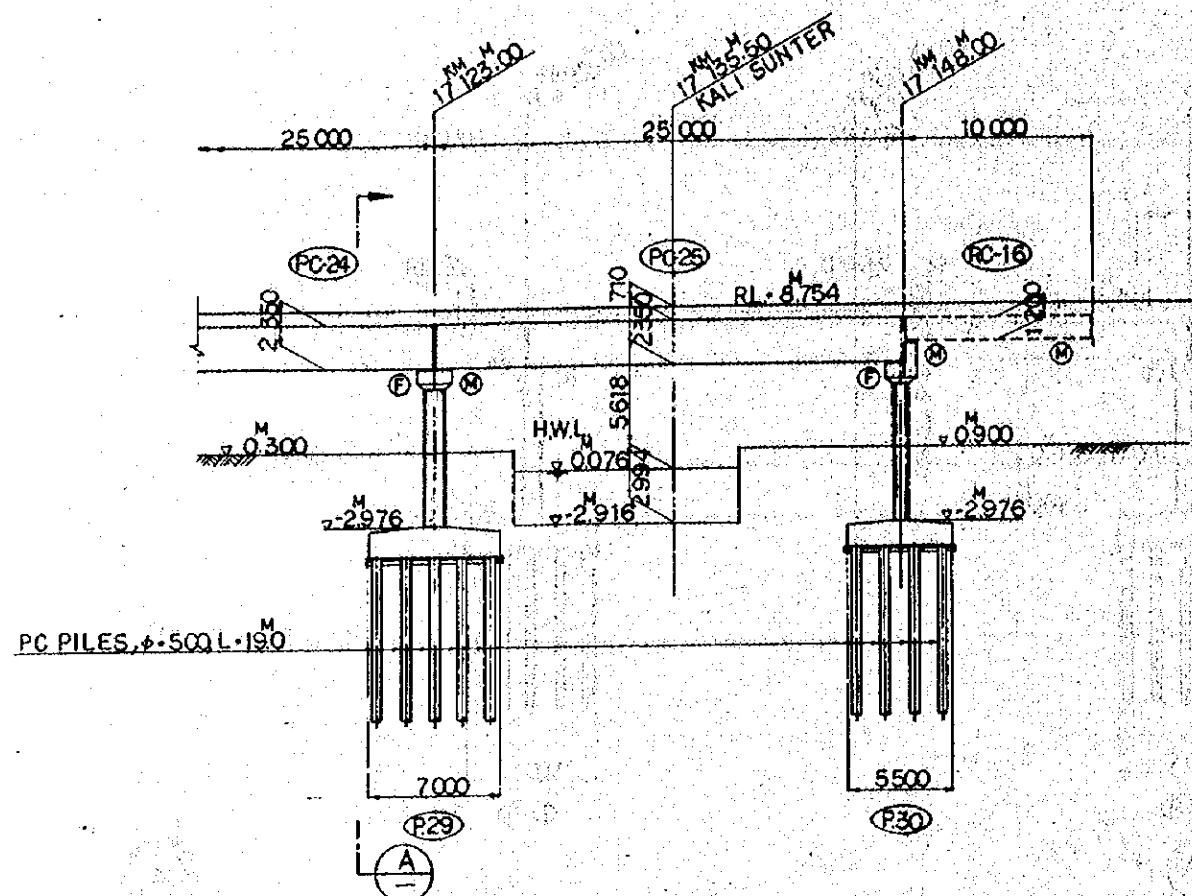

- NOTES:
1. ALL DIMENSIONS ARE SHOWN IN MILLIMETERS UNLESS OTHERWISE INDICATED
  2. REFERENCE DRAWING FOR GENERAL VIEW: CS044, CS215, CS103, CS106.
  3. CODE:
    - ⊕---FIXED BEARING
    - ⊗---EXPANSION BEARING

LONGITUDINAL SECTION

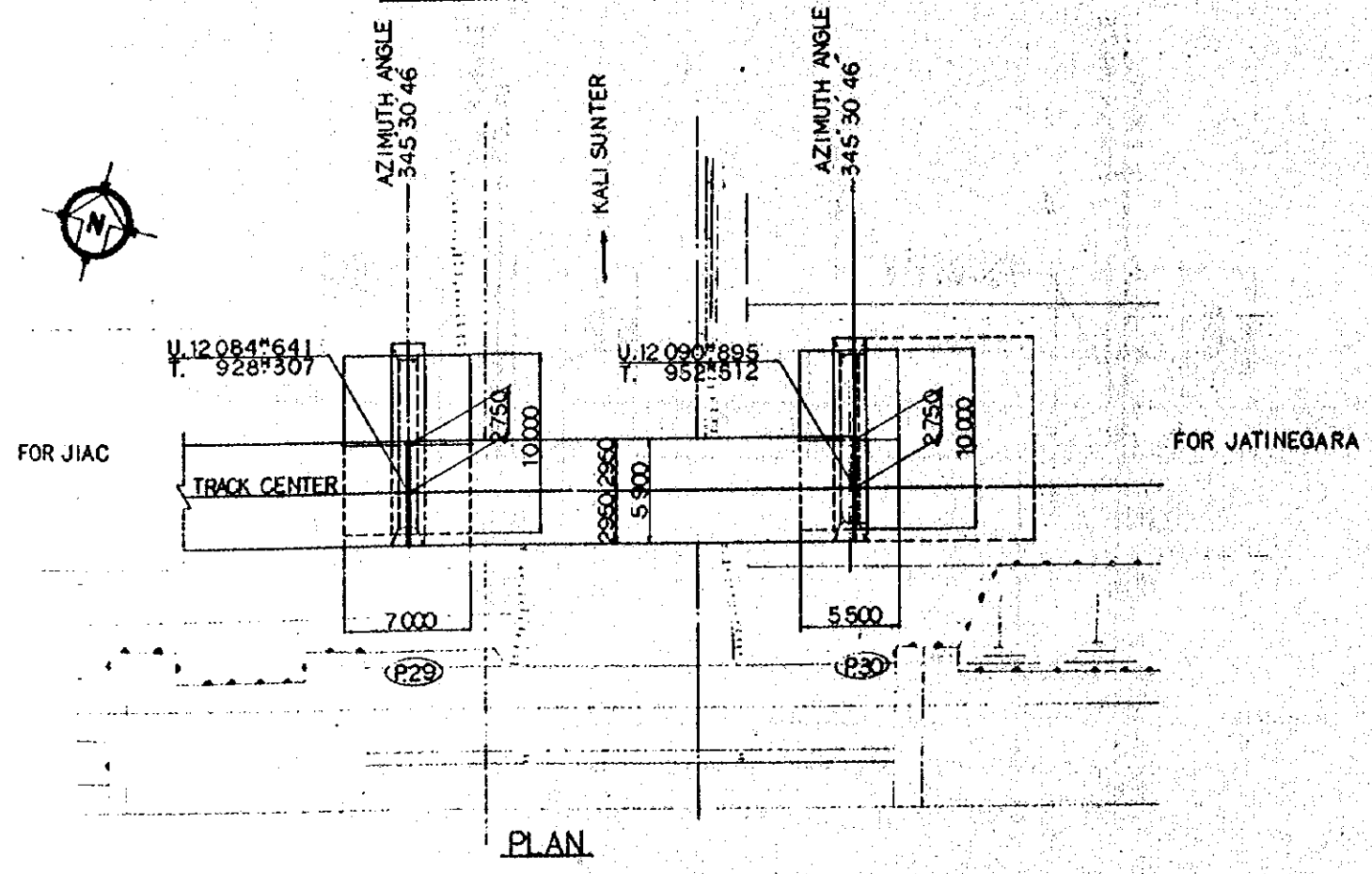

PLAN

REPUBLIC OF INDONESIA MINISTRY OF COMMUNICATIONS DIRECTORATE GENERAL OF LAND TRANSPORT AND INLAND WATERWAYS					
NEW RAILWAY LINE FOR CENGKARENG AIRPORT CONSTRUCTION PROJECT					
JAPAN INTERNATIONAL COOPERATION AGENCY (JICA)					
B	1 AUG. 84	MY	m.y	K.A.	K.V. m.K.
A	15 FEB. 84	MY	m.y	K.A.	K.V. m.K.
REVISION	DATE	DESIGNED	DRAWN	CHECKED	REVIEWED
BRIDGE B08 GENERAL VIEW (SHEET 2 OF 2)					
PACKAGE: I CIVIL AND ARCHITECTURAL WORK					
SCALE: 1:200		DRAWING NO: CS-012			

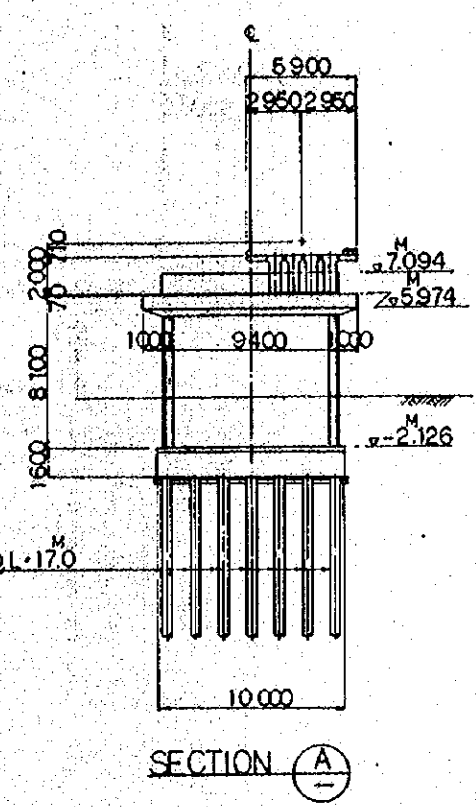
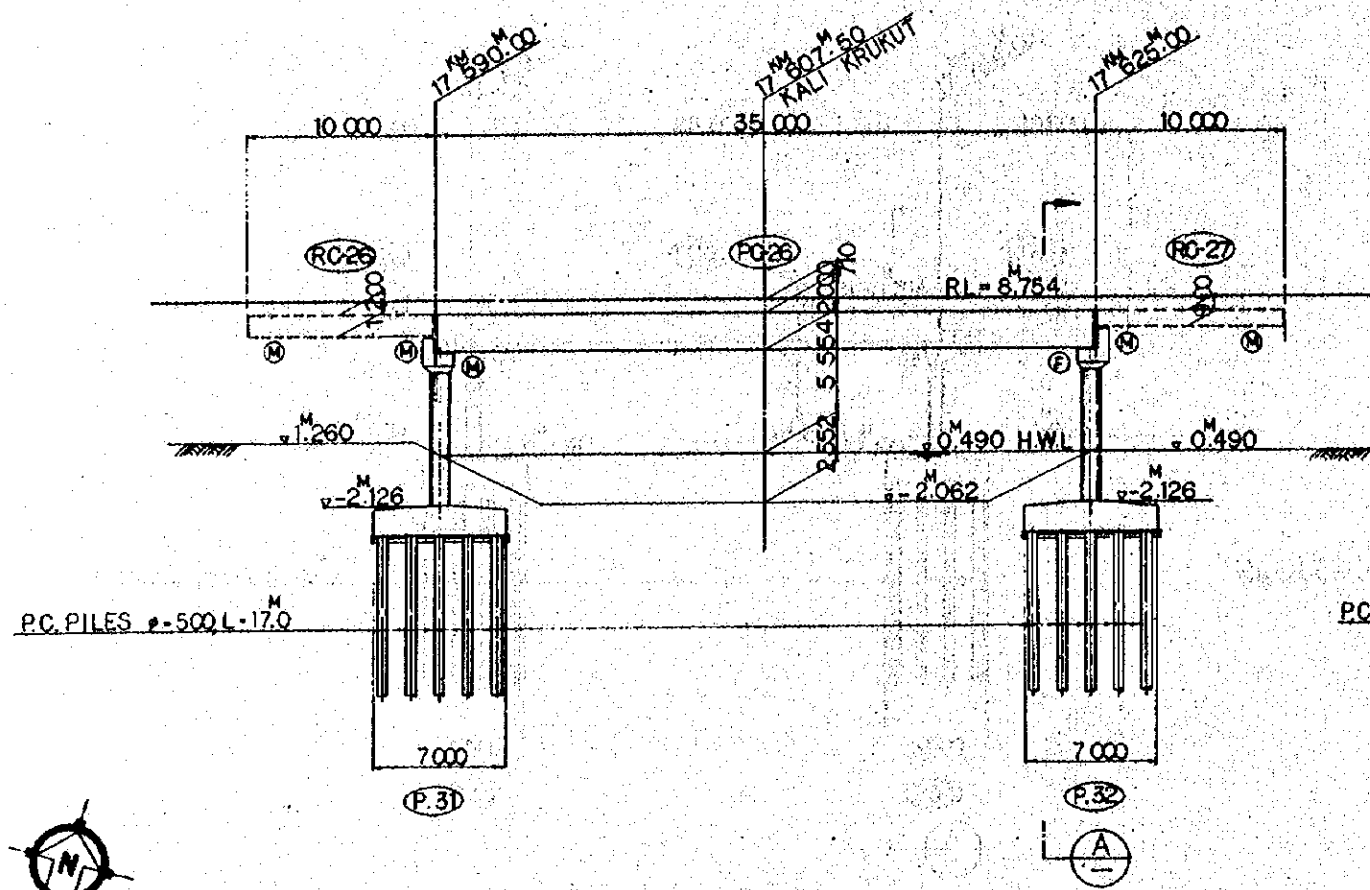

LONGITUDINAL SECTION

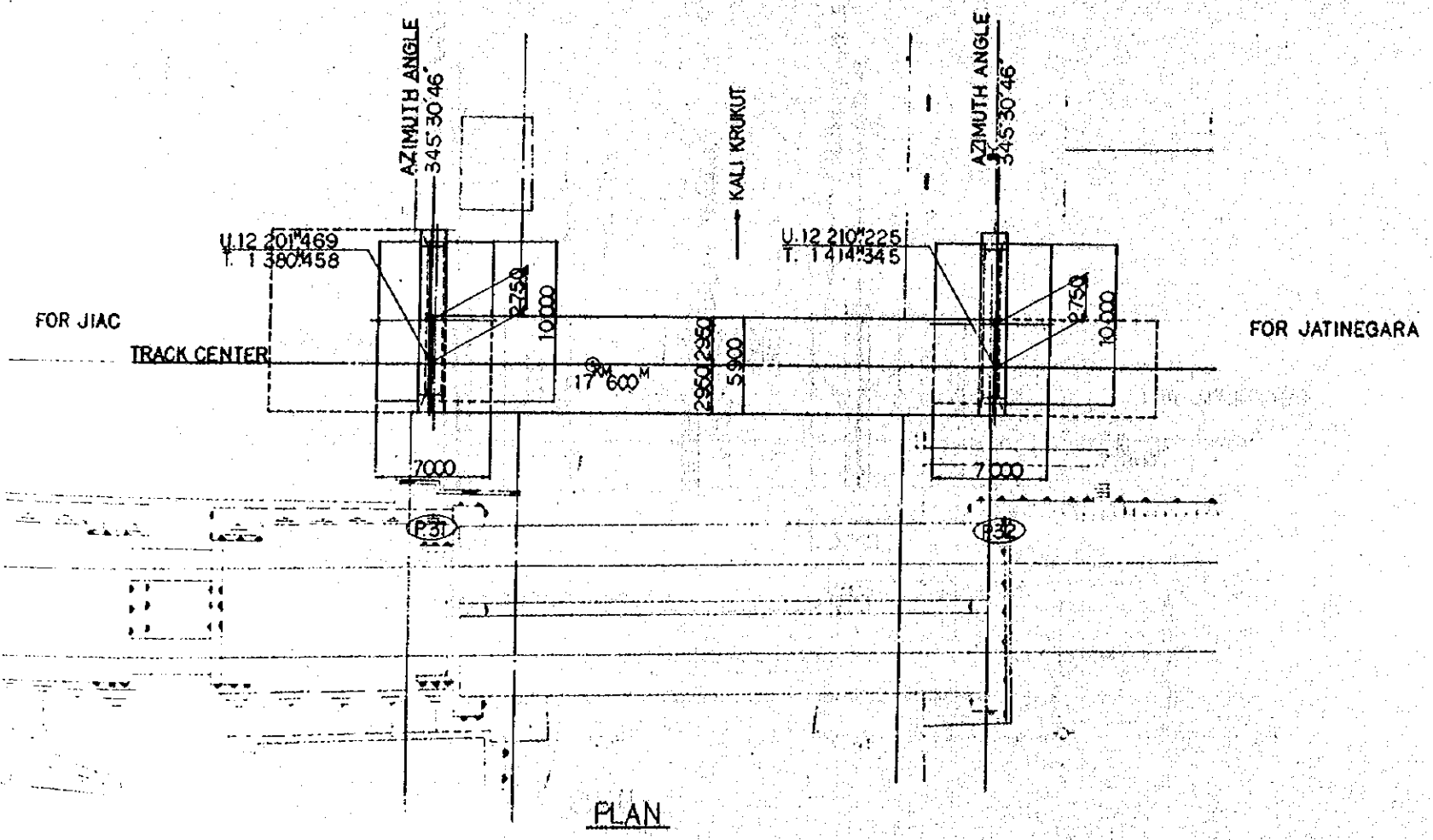

PLAN

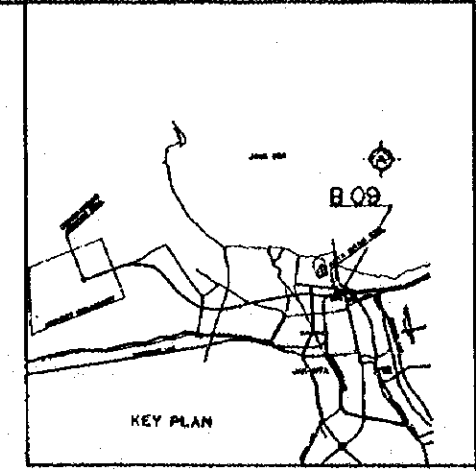

- NOTES:
1. ALL DIMENSIONS ARE SHOWN IN MILLIMETERS UNLESS OTHERWISE INDICATED
  2. REFERENCE DRAWING FOR GENERAL VIEW: CS185, CS039, CS029, CS-110
  3. CODE:
    - ⊕---- FIXED BEARING
    - ⊙---- EXPANSION BEARING

REPUBLIC OF INDONESIA MINISTRY OF COMMUNICATIONS DIRECTORATE GENERAL OF LAND TRANSPORT AND INLAND WATERWAYS						
NEW RAILWAY LINE FOR CENGKARENG AIRPORT CONSTRUCTION PROJECT						
JAPAN INTERNATIONAL COOPERATION AGENCY (JICA)						
B	1 AUG 84	NY	MY	KA	KM	MK
A	15 FEB 84	NY	MY	KA	KM	MK
REVISION	DATE	DESIGNED	DRAWN	CHECKED	REVIEWED	SUBMITTED
<b>BRIDGE B09</b> <b>GENERAL VIEW</b>						
PACKAGE: I CIVIL AND ARCHITECTURAL WORK						
SCALE: 1:200		DRAWING NO: CS-013				

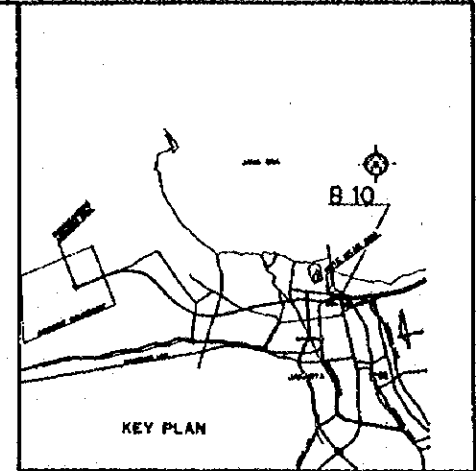

- NOTES:
1. ALL DIMENSIONS ARE SHOWN IN MILLIMETERS UNLESS OTHERWISE INDICATED
  2. REFERENCE DRAWING FOR GENERAL VIEW: CS-185, CS029, CS106
  3. CODE:
    - ⊕---FIXED BEARING
    - ⊙---EXPANSION BEARING

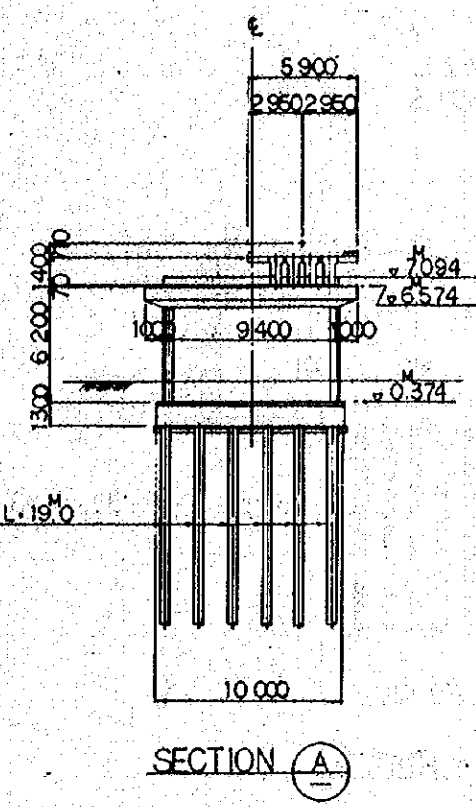
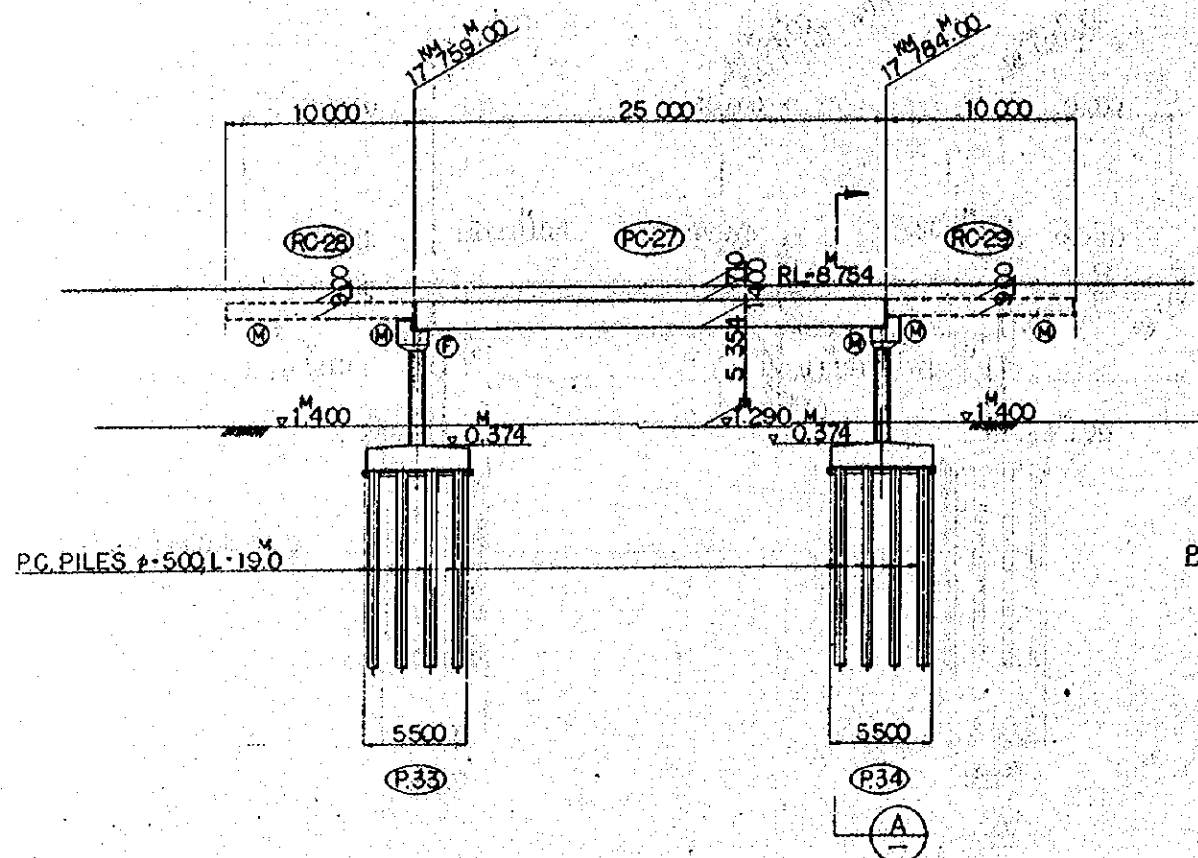

LONGITUDINAL SECTION

SECTION A

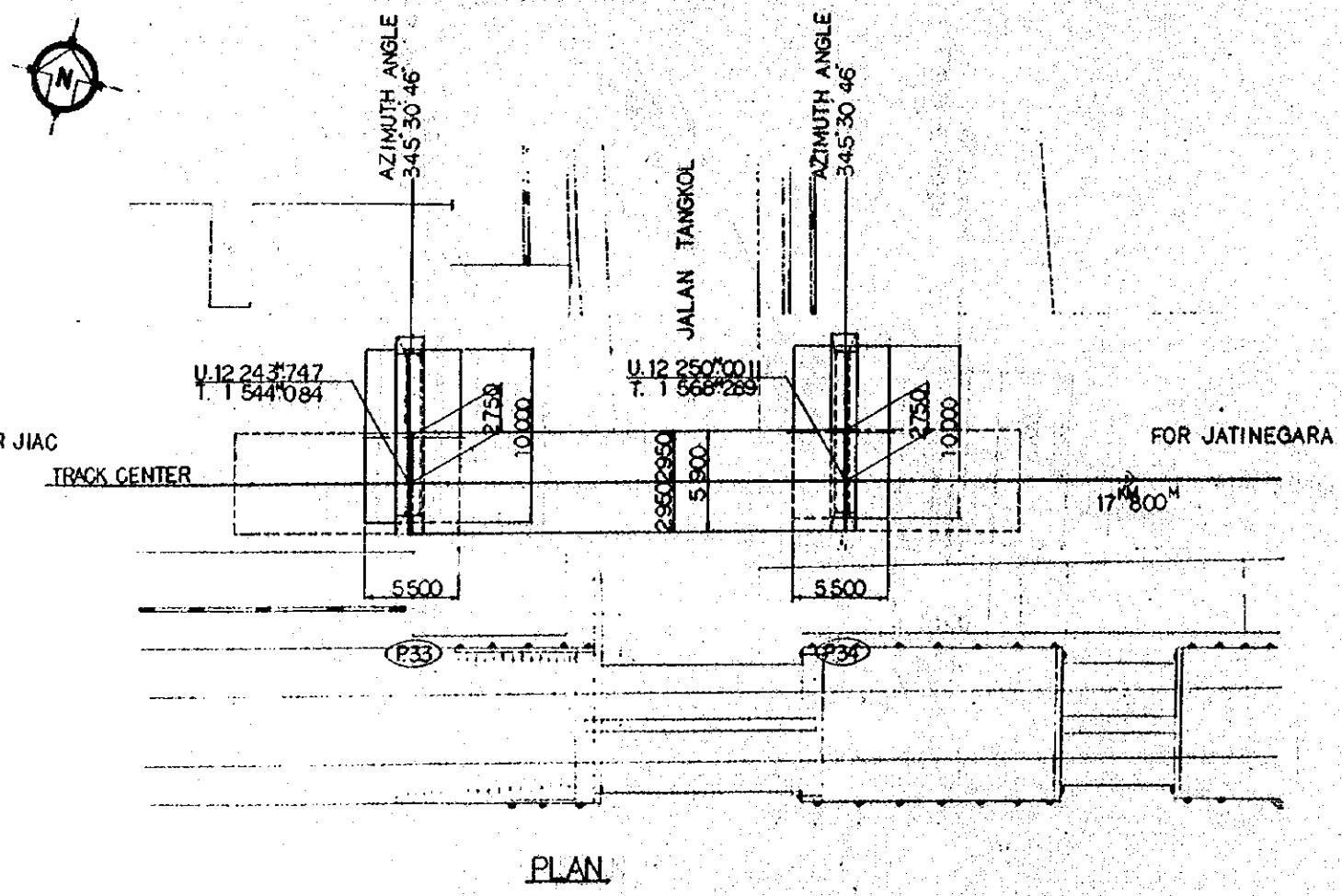

PLAN

REPUBLIC OF INDONESIA MINISTRY OF COMMUNICATIONS DIRECTORATE GENERAL OF LAND TRANSPORT AND INLAND WATERWAYS					
NEW RAILWAY LINE FOR GENGKARENG AIRPORT CONSTRUCTION PROJECT					
JAPAN INTERNATIONAL COOPERATION AGENCY (JICA)					
B	1 AUG '84	RY	m.y.	K.A.	K.M.
A	15 FEB '84	RY	m.y.	K.A.	K.M.
REVISIONS	DATE	DESIGNED	DRAWN	CHECKED	APPROVED
BRIDGE B10 GENERAL VIEW					
PACKAGE: I CIVIL AND ARCHITECTURAL WORK					
SCALE: 1:200		DRAWING NO: CS-014			

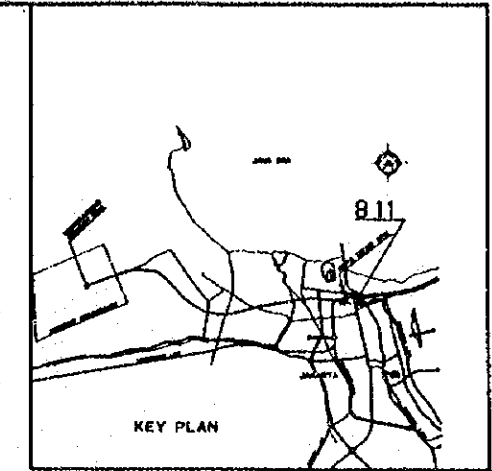
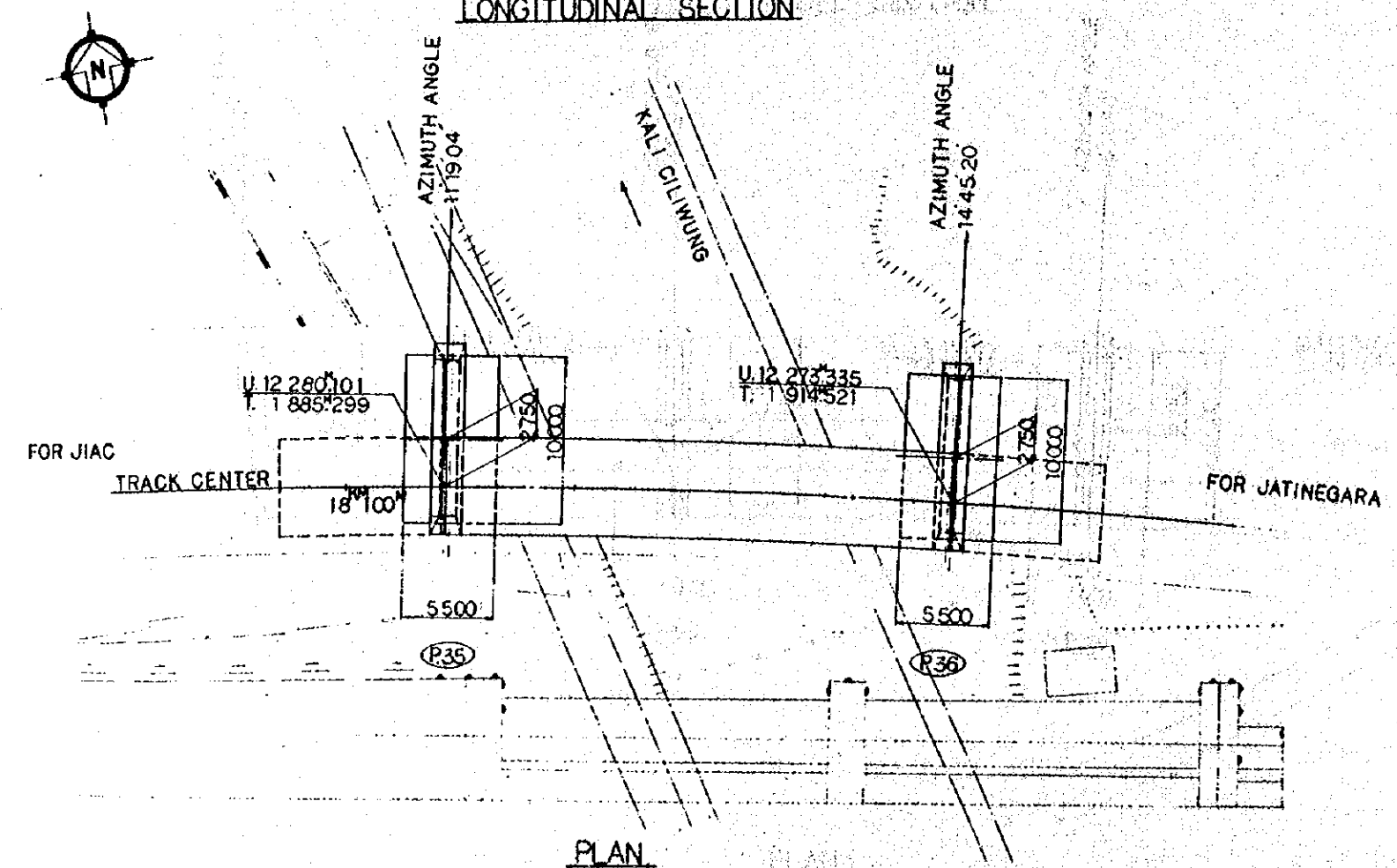
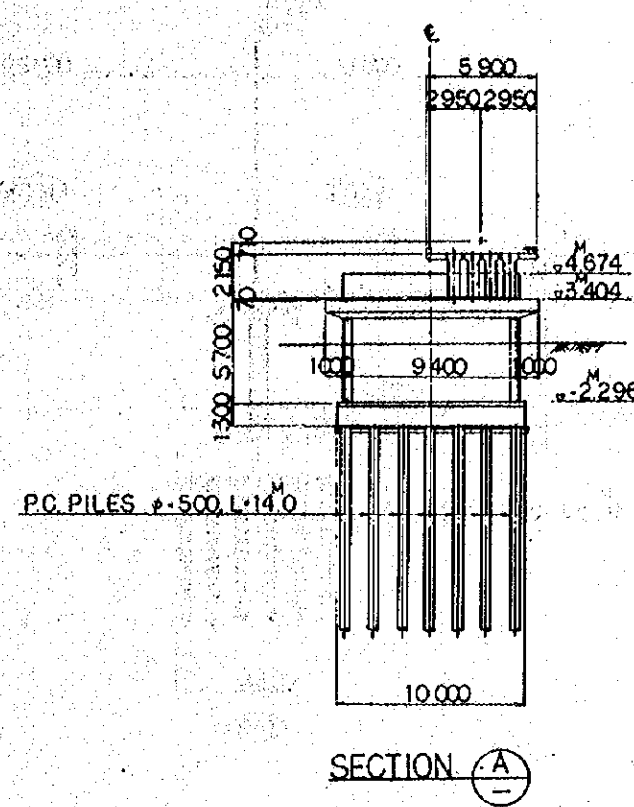
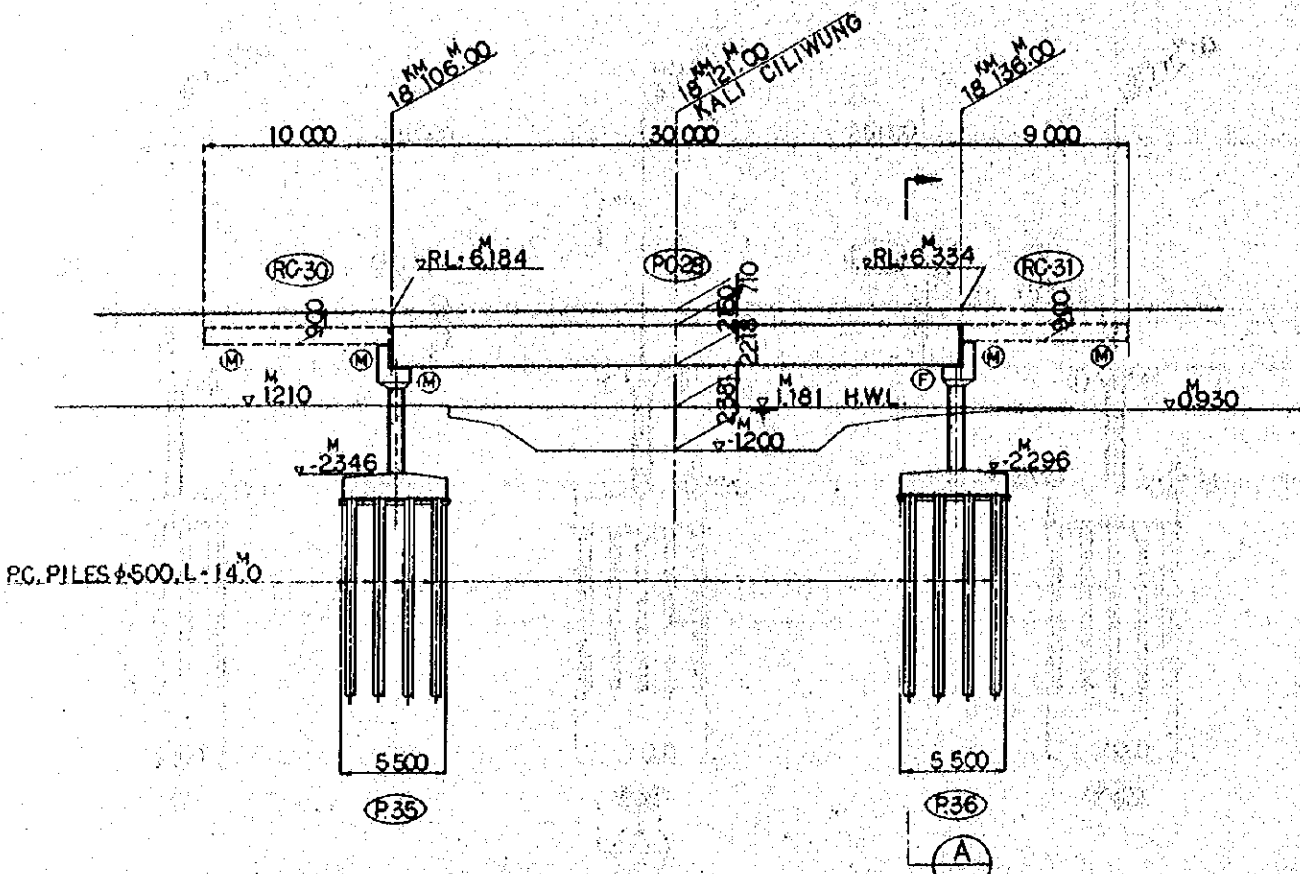

- NOTES:
1. ALL DIMENSIONS ARE SHOWN IN MILLIMETERS UNLESS OTHERWISE INDICATED
  2. REFERENCE DRAWING FOR GENERAL VIEW: CS-190, CS-045, CS-088, CS-089
  3. CODE:
    - ⊕ --- FIXED BEARING
    - ⊗ --- EXPANSION BEARING

REPUBLIC OF INDONESIA MINISTRY OF COMMUNICATIONS DIRECTORATE GENERAL OF LAND TRANSPORT AND INLAND WATERWAYS					
NEW RAILWAY LINE FOR CEMKARENG AIRPORT CONSTRUCTION PROJECT					
JAPAN INTERNATIONAL COOPERATION AGENCY (JICA)					
B	1 AUG. 84	M.Y.	M.Y.	K.A.	K.M. M.K.
A	15 FEB. 84	M.Y.	M.Y.	K.A.	K.M. M.K.
REVISIONS	DATE	DESIGNED	DRAWN	CHECKED	REVIEWED
<b>BRIDGE B11</b> <b>GENERAL VIEW</b>					
PACKAGE: I CIVIL AND ARCHITECTURAL WORK					
SCALE: 1:200		DRAWING NO: CS-015			

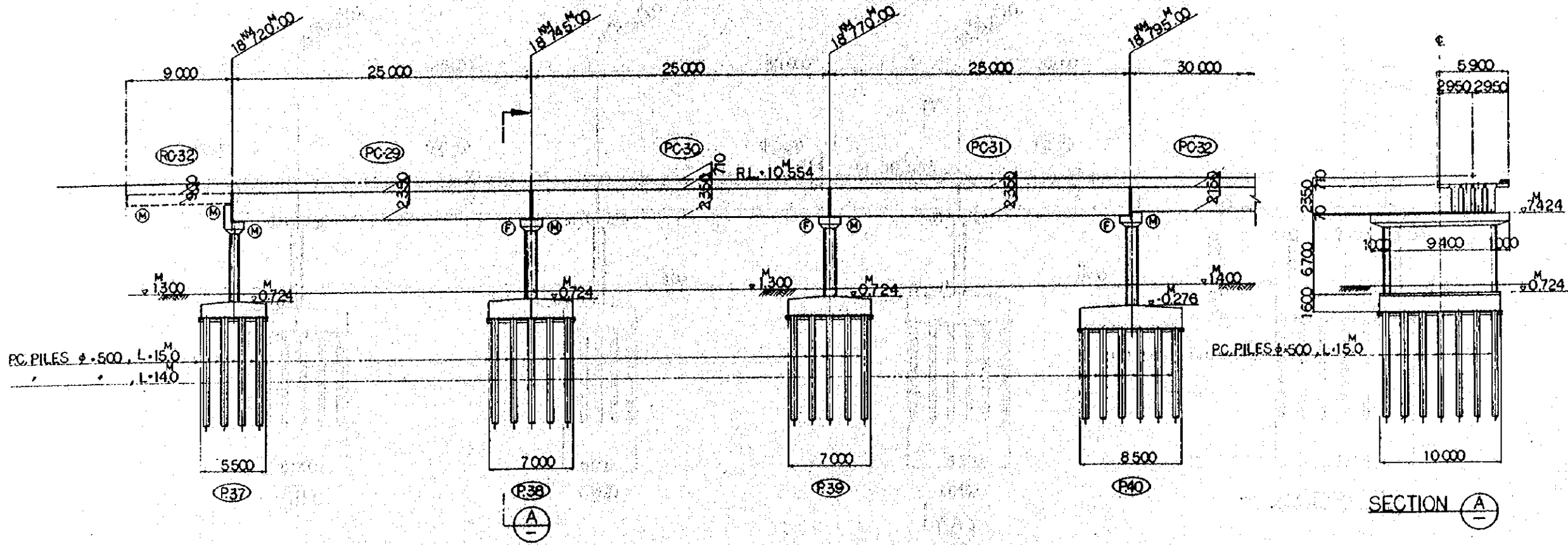

LONGITUDINAL SECTION

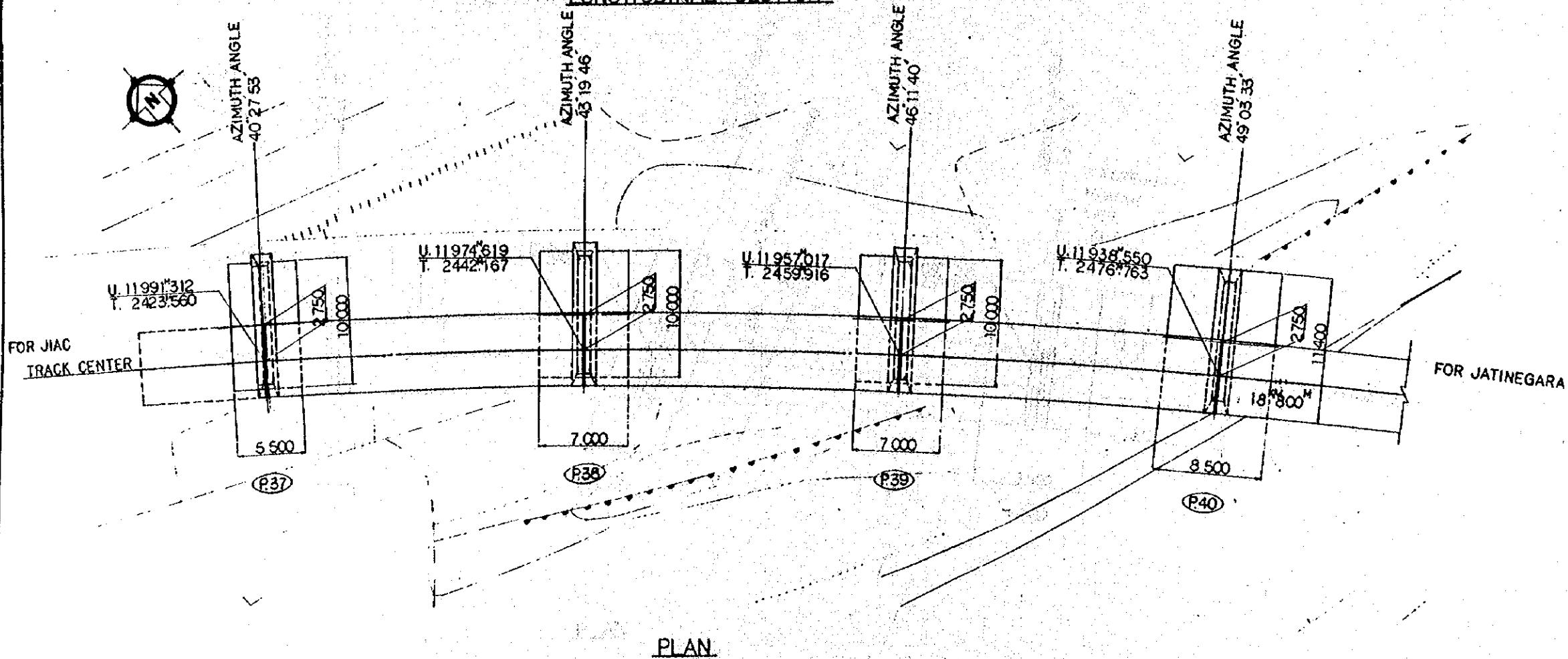

PLAN

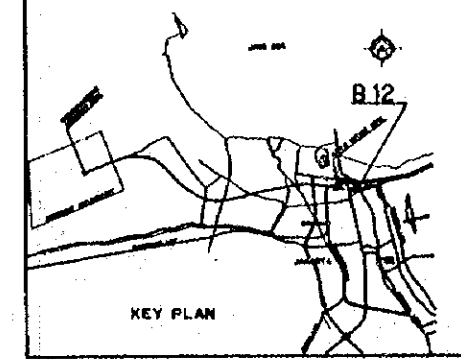

- NOTES:
1. ALL DIMENSIONS ARE SHOWN IN MILLIMETERS UNLESS OTHERWISE INDICATED
  2. REFERENCE DRAWING FOR GENERAL VIEW: CS190, CS049, CS045, CS077, CS103, CS111.
  3. CODE:
    - ⊙ --- FIXED BEARING
    - ⊗ --- EXPANSION BEARING

REPUBLIC OF INDONESIA MINISTRY OF COMMUNICATIONS DIRECTORATE GENERAL OF LAND TRANSPORT AND INLAND WATERWAYS						
NEW RAILWAY LINE FOR CENKARENG AIRPORT CONSTRUCTION PROJECT						
JAPAN INTERNATIONAL COOPERATION AGENCY (JICA)						
B	1 AUG '84	NY	my	KA	GM	AK
A	15 FEB '84	NY	my	KA	GM	AK
REVISION	DATE	DRAWN	CHECKED	REVIEWED	SUBMITTED	
BRIDGE B12 GENERAL VIEW (SHEET 1 OF 2)						
PACKAGE: I CIVIL AND ARCHITECTURAL WORK						
SCALE: 1:200		DRAWING NO: CS-016				



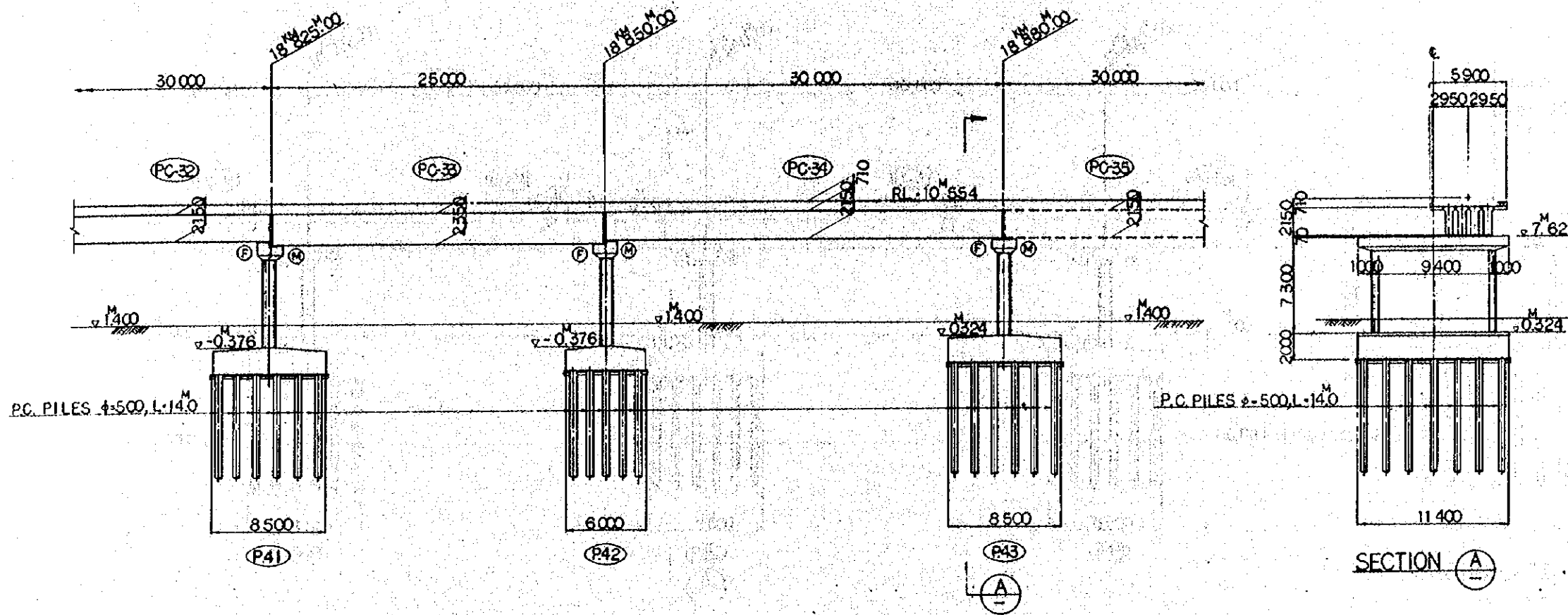

LONGITUDINAL SECTION

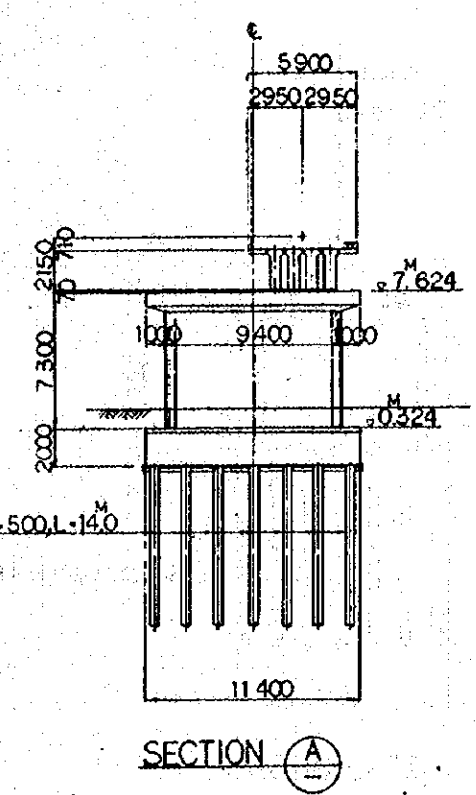

SECTION A

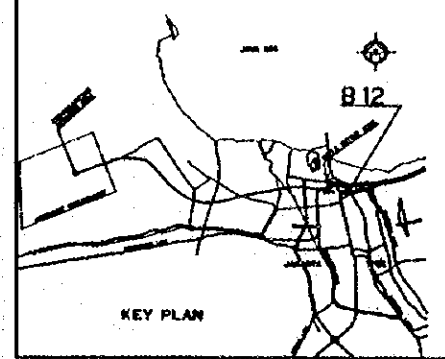

- NOTES:
1. ALL DIMENSIONS ARE SHOWN IN MILLIMETERS UNLESS OTHERWISE INDICATED
  2. REFERENCE DRAWING FOR GENERAL VIEW: CS045, CS053, CS054, CS111, CS115, CS090.

3. CODE:
- ⊙ --- FIXED BEARING
  - ⊕ --- EXPANSION BEARING

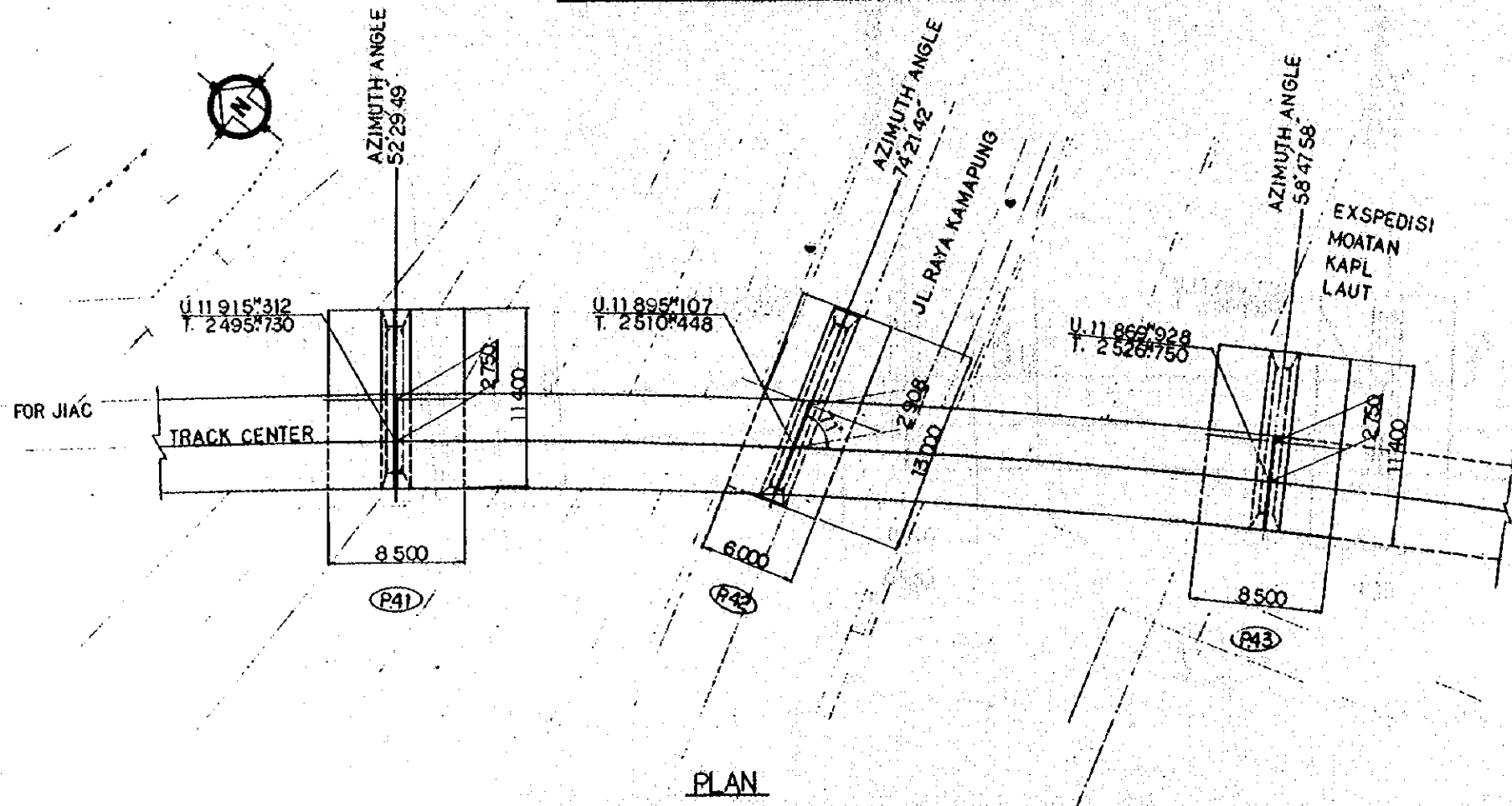

PLAN

REPUBLIC OF INDONESIA MINISTRY OF COMMUNICATIONS DIRECTORATE GENERAL OF LAND TRANSPORT AND INLAND WATERWAYS						
NEW RAILWAY LINE FOR CENKARENS AIRPORT CONSTRUCTION PROJECT						
JAPAN INTERNATIONAL COOPERATION AGENCY (JICA)						
B	1 AUG '84	M.Y.	M.Y.	K.A.	K.M.	M.K.
A	15 FEB '84	M.Y.	M.Y.	K.A.	K.M.	M.K.
REVISIONS	DATE	DESIGNED	CHECKED	REVIEWED	APPROVED	
BRIDGE B12 GENERAL VIEW (SHEET 2 OF 2)						
PACKAGE: I CIVIL AND ARCHITECTURAL WORK						
SCALE: 1:200		DRAWING NO: CS-017				

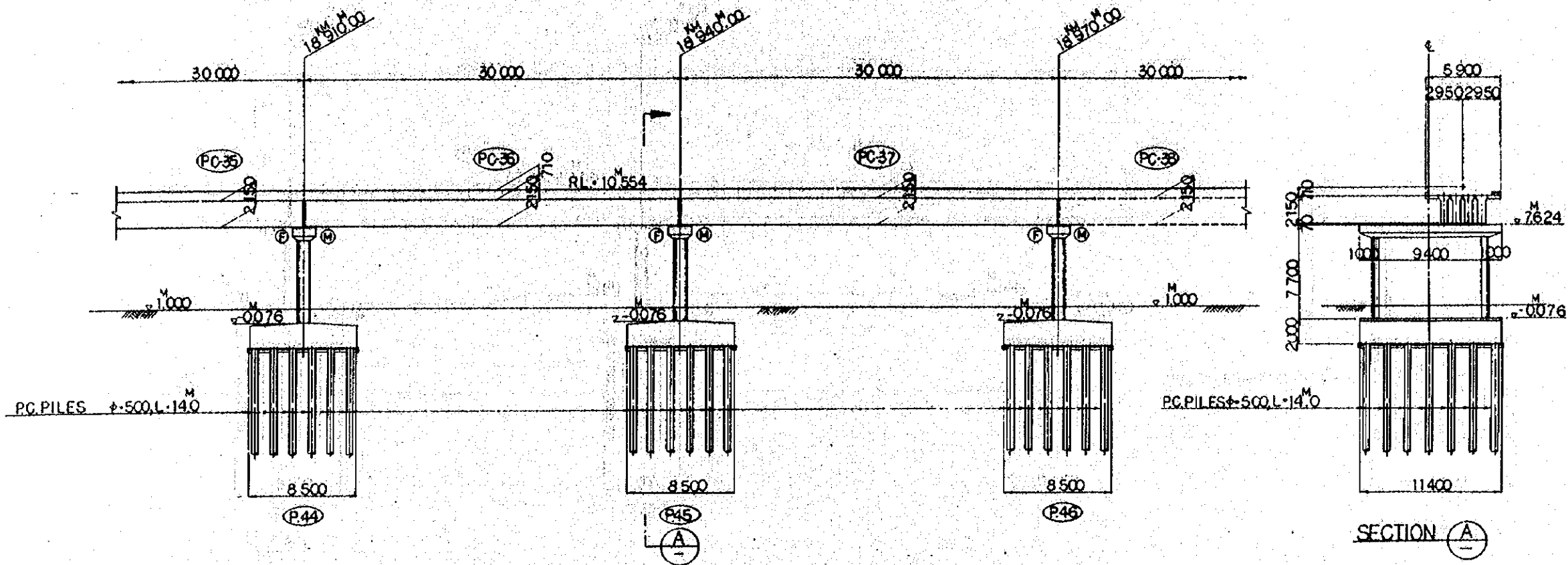

LONGITUDINAL SECTION

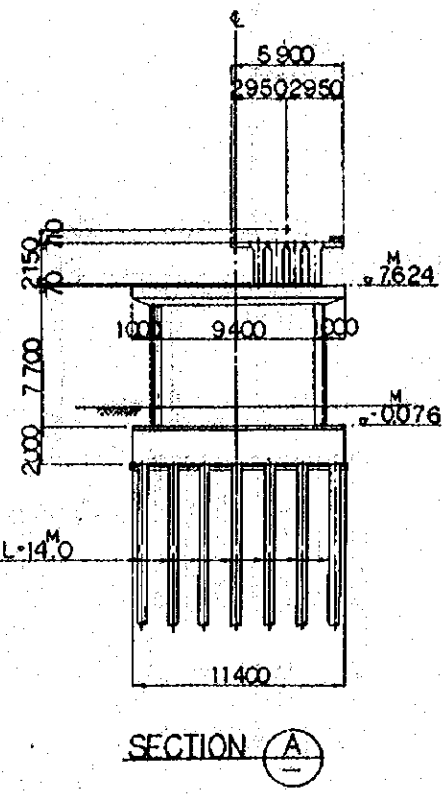

SECTION A

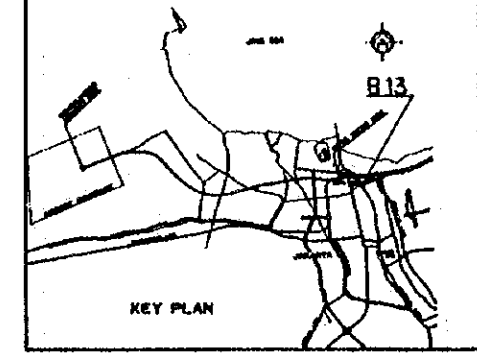

- NOTES:
1. ALL DIMENSIONS ARE SHOWN IN MILLIMETERS UNLESS OTHERWISE INDICATED
  2. REFERENCE DRAWING FOR GENERAL VIEW: CS045.CS090.
  3. CODE :
    - ⊕---- FIXED BEARING
    - ⊕---- EXPANSION BEARING

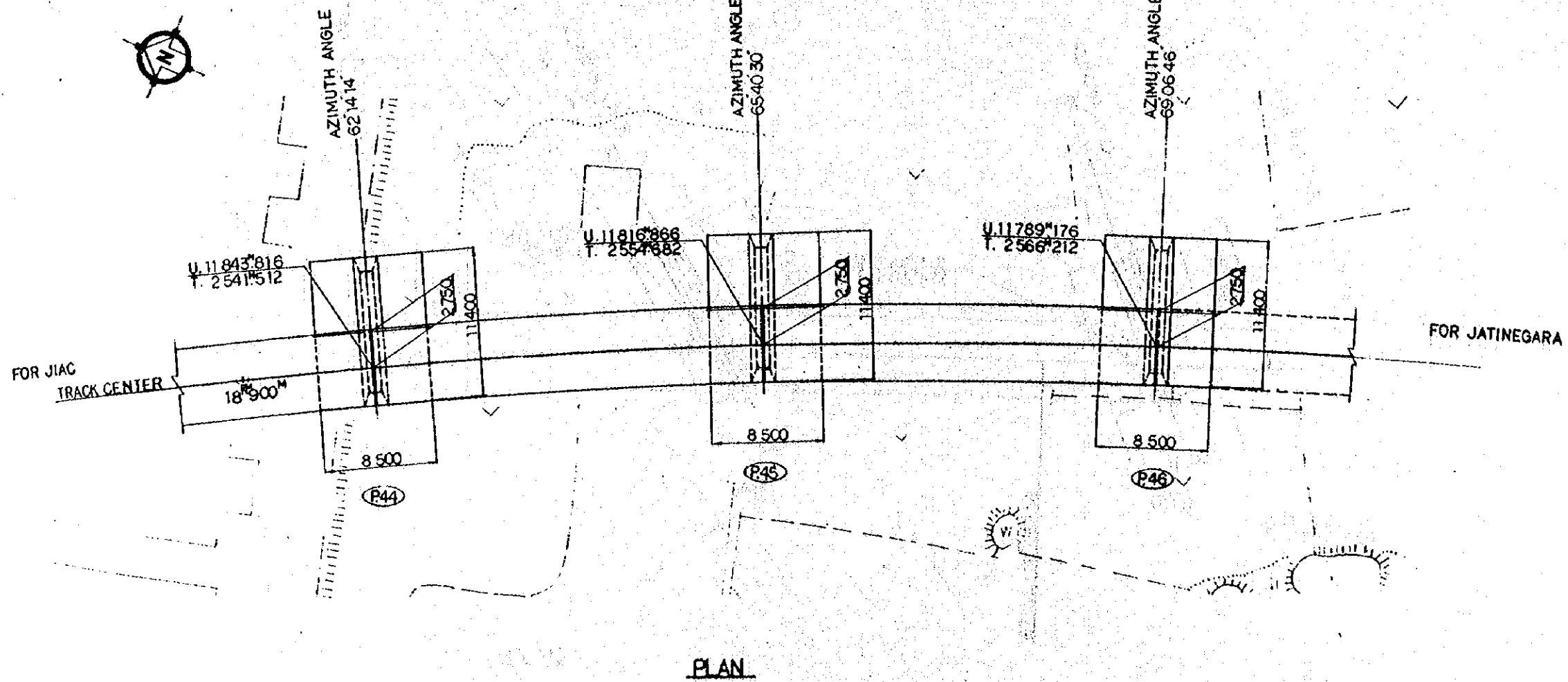

PLAN

REPUBLIC OF INDONESIA MINISTRY OF COMMUNICATIONS DIRECTORATE GENERAL OF LAND TRANSPORT AND INLAND WATERWAYS					
NEW RAILWAY LINE FOR CENKARENG AIRPORT CONSTRUCTION PROJECT					
JAPAN INTERNATIONAL COOPERATION AGENCY (JICA)					
B	1AUG.'84	NY	M.Y	K.A	M.K
A	15 FEB.'84	NY	M.Y	K.A	M.K
REVISIONS	DATE	DESIGNED	CHECKED	REVIEWED	APPROVED
<b>BRIDGE B13</b> <b>GENERAL VIEW</b>					
PACKAGE: I CIVIL AND ARCHITECTURAL WORK					
SCALE: 1:200		DRAWING NO: CS-018			

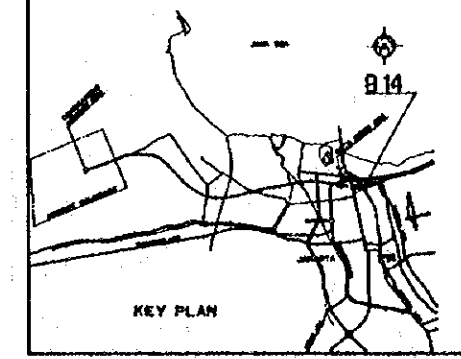
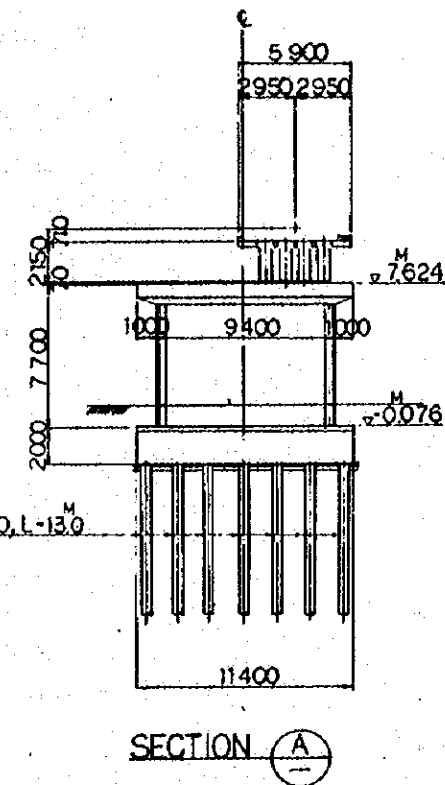
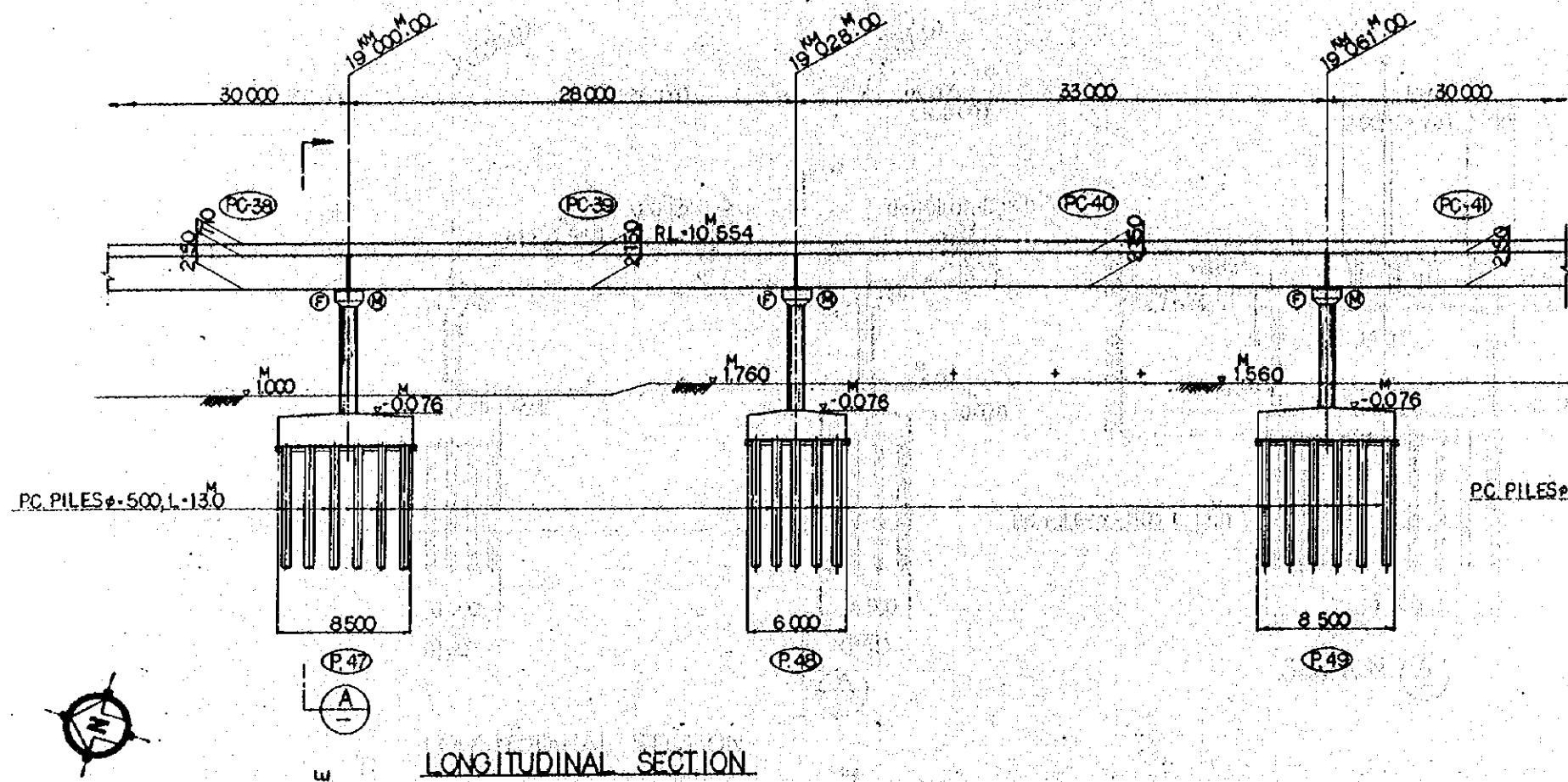

- NOTES:
1. ALL DIMENSIONS ARE SHOWN IN MILLIMETERS UNLESS OTHERWISE INDICATED
  2. REFERENCE DRAWING FOR GENERAL VIEW: CS-045, CS-055, CS-056, CS-061, CS-116, CS-117, CS-121.
  3. CODE:
    - ⊕ --- FIXED BEARING
    - ⊗ --- EXPANSION BEARING

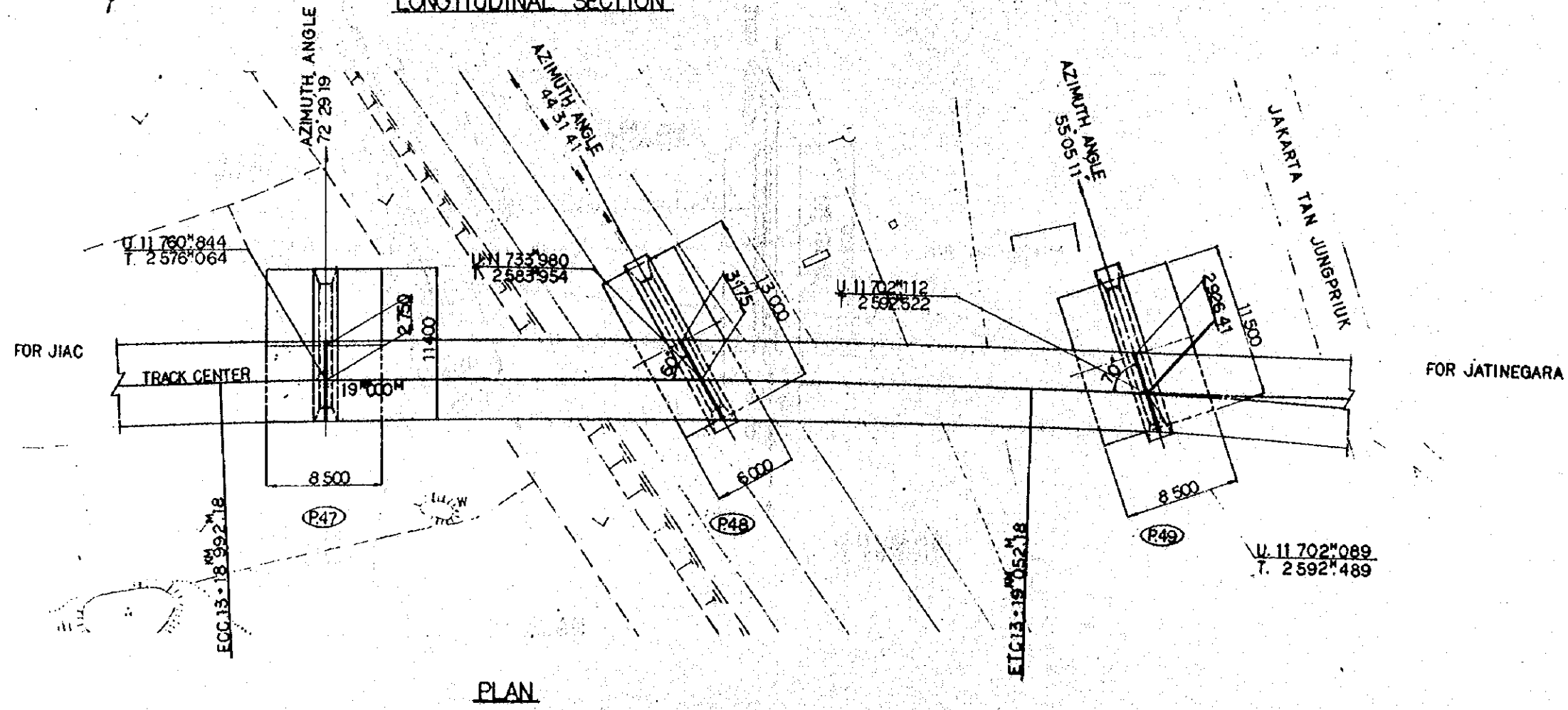

REPUBLIC OF INDONESIA MINISTRY OF COMMUNICATIONS DIRECTORATE GENERAL OF LAND TRANSPORT AND INLAND WATERWAYS					
NEW RAILWAY LINE FOR GEMKARENG AIRPORT CONSTRUCTION PROJECT					
JAPAN INTERNATIONAL COOPERATION AGENCY (JICA)					
B	1 AUG '84	HY	MY	KY	KM
A	15 FEB '84	HY	MY	KY	KM
REVISIONS	DATE	DESIGNED	CHECKED	APPROVED	SUBMITTED
BRIDGE B14 GENERAL VIEW (SHEET 1 OF 2)					
PACKAGE: I CIVIL AND ARCHITECTURAL WORK					
SCALE: 1:200		DRAWING NO: CS-019			

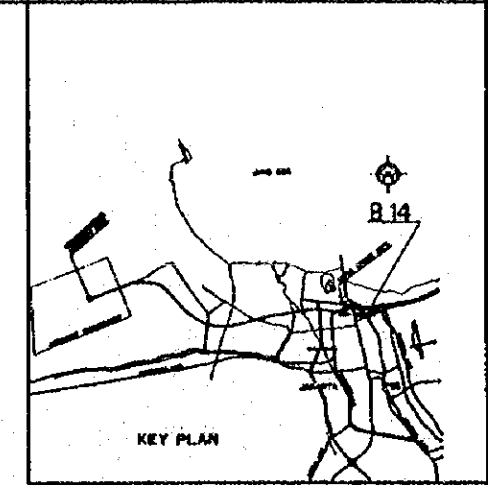
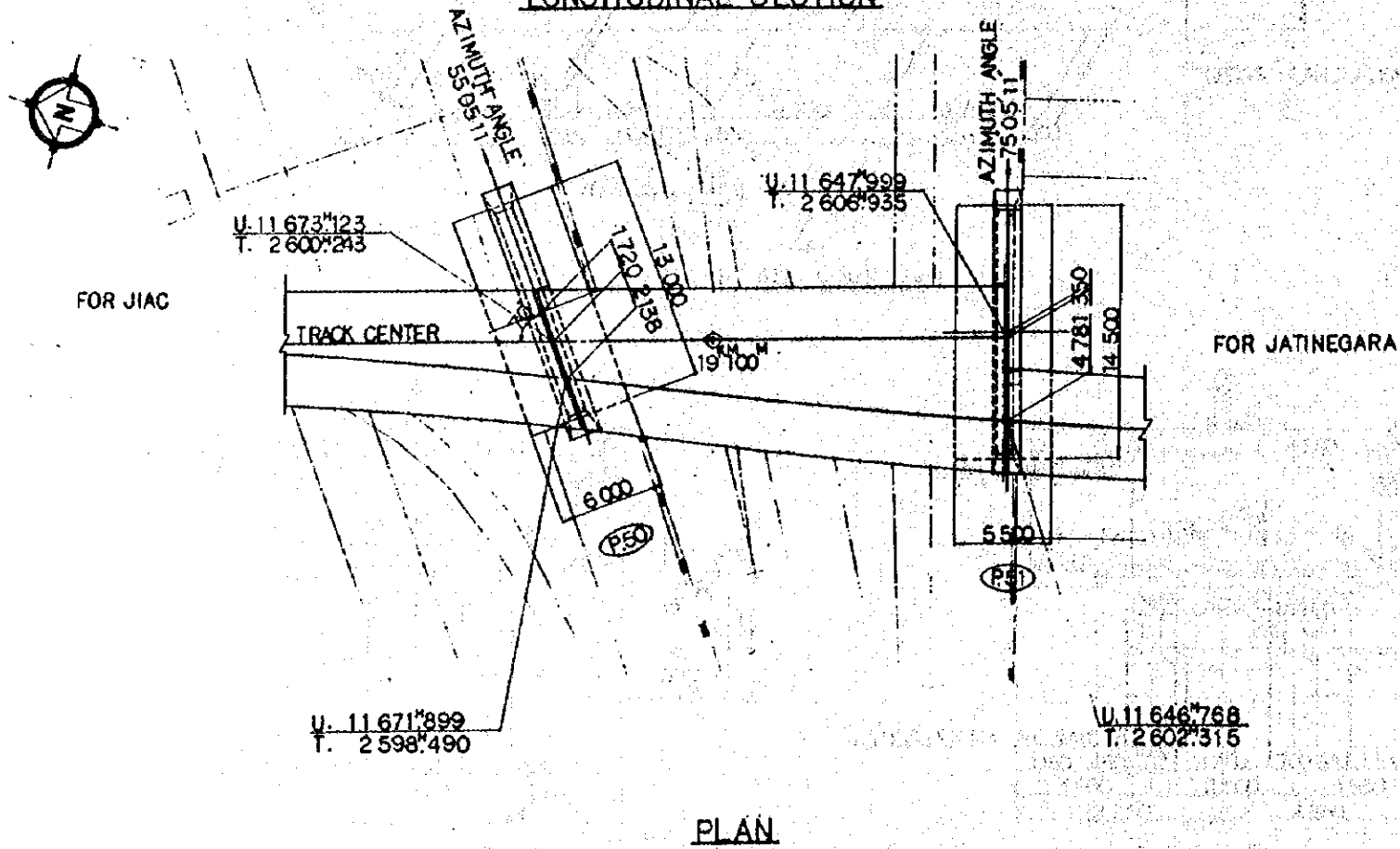
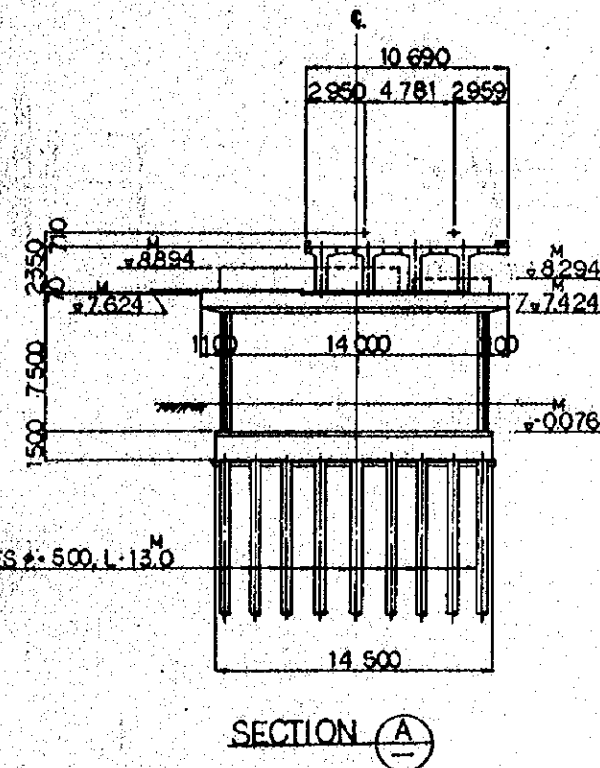
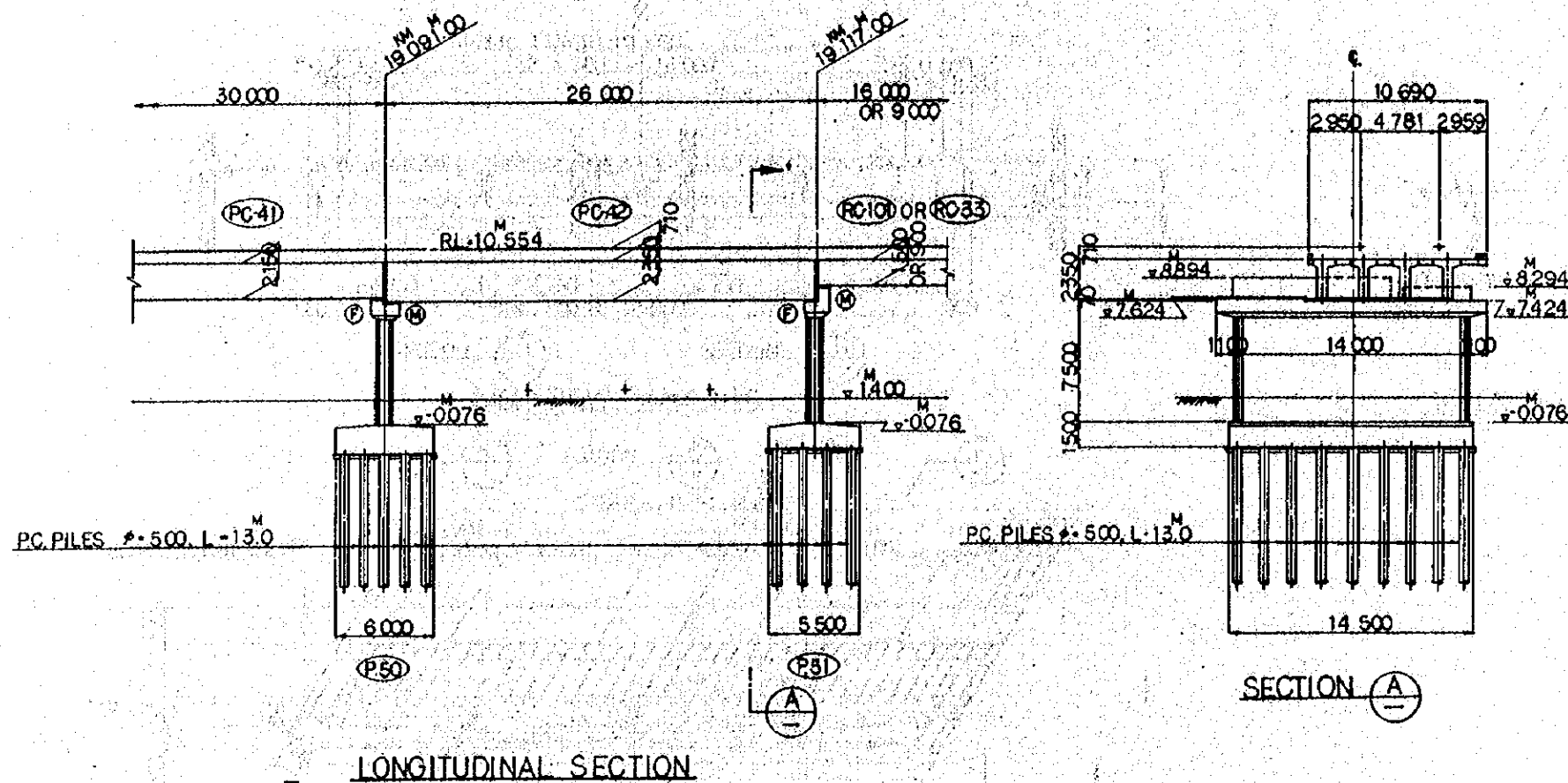

NOTES:

1. ALL DIMENSIONS ARE SHOWN IN MILLIMETERS UNLESS OTHERWISE INDICATED
2. REFERENCE DRAWING FOR GENERAL VIEW: CS-061, CS-062, CS-185, CS-275, CS-426, CS-126.

a. CODE:

- ⊖---FIXED BEARING
- ⊕---EXPANSION BEARING

REPUBLIC OF INDONESIA MINISTRY OF COMMUNICATIONS DIRECTORATE GENERAL OF LAND TRANSPORT AND INLAND WATERWAYS						
NEW RAILWAY LINE FOR CENKARENG AIRPORT CONSTRUCTION PROJECT						
JAPAN INTERNATIONAL COOPERATION AGENCY (JICA)						
B	1 AUG'84	REV	REV	REV	REV	REV
A	15 FEB.84	REV	REV	REV	REV	REV
REVISIONS	DATE	BY	CHECKED	DESIGNED	APPROVED	REVISIONS
<b>BRIDGE B14</b> <b>GENERAL VIEW</b> <b>(SHEET 2 OF 2)</b>						
PROJECT: I CIVIL AND ARCHITECTURAL WORK						
SCALE 1:200		DRAWING NO. CS-020				

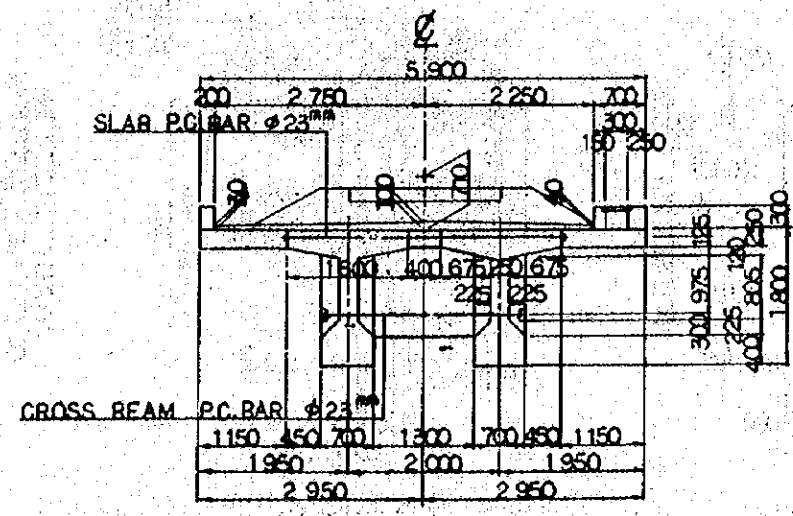
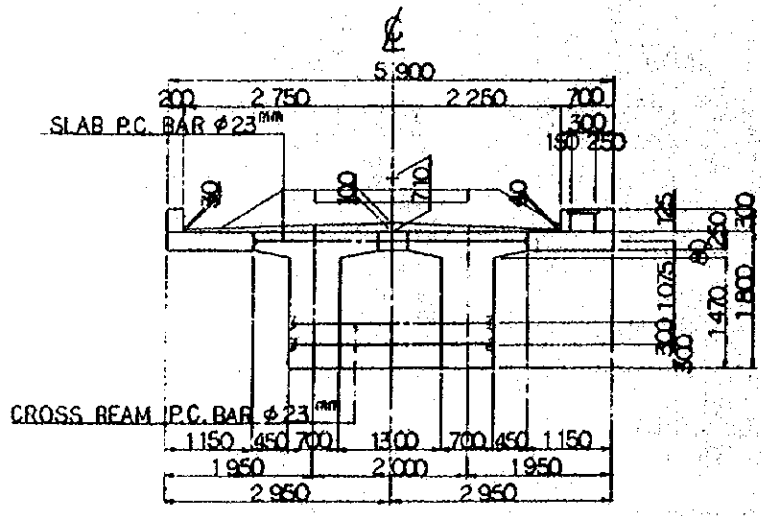
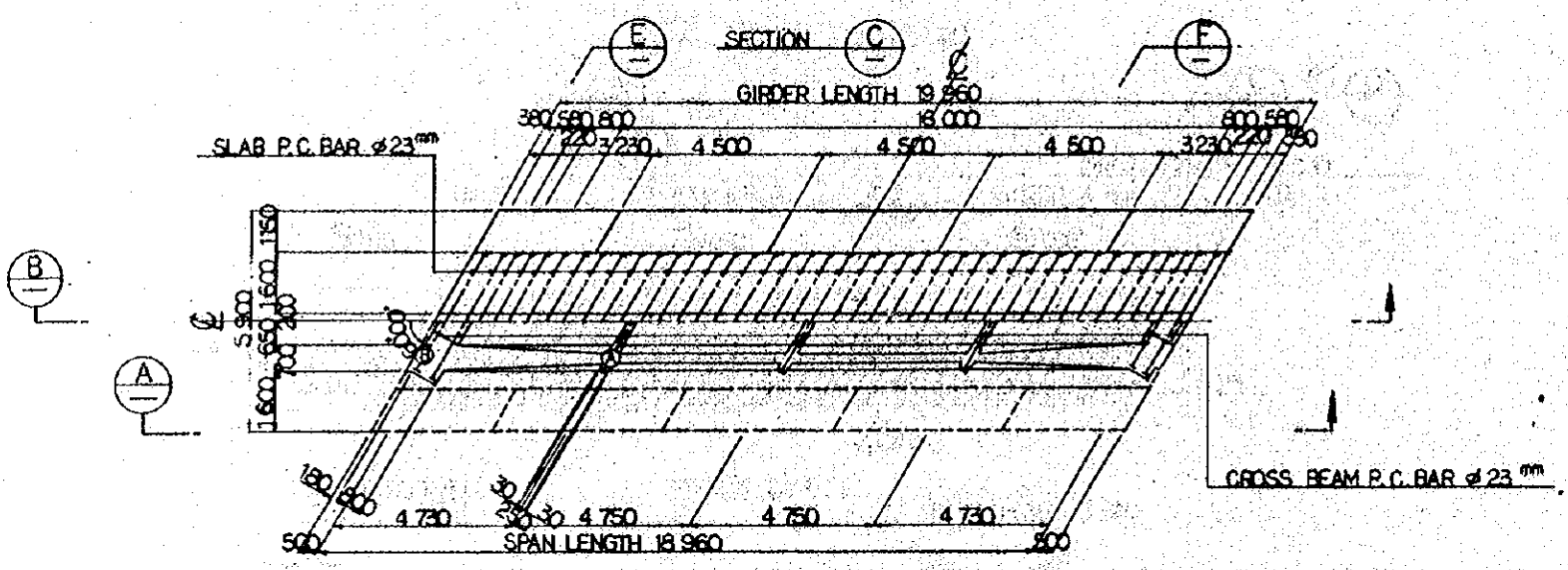
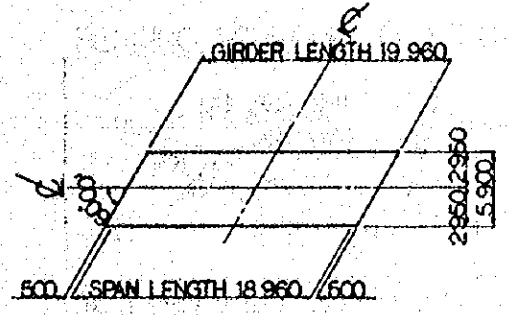
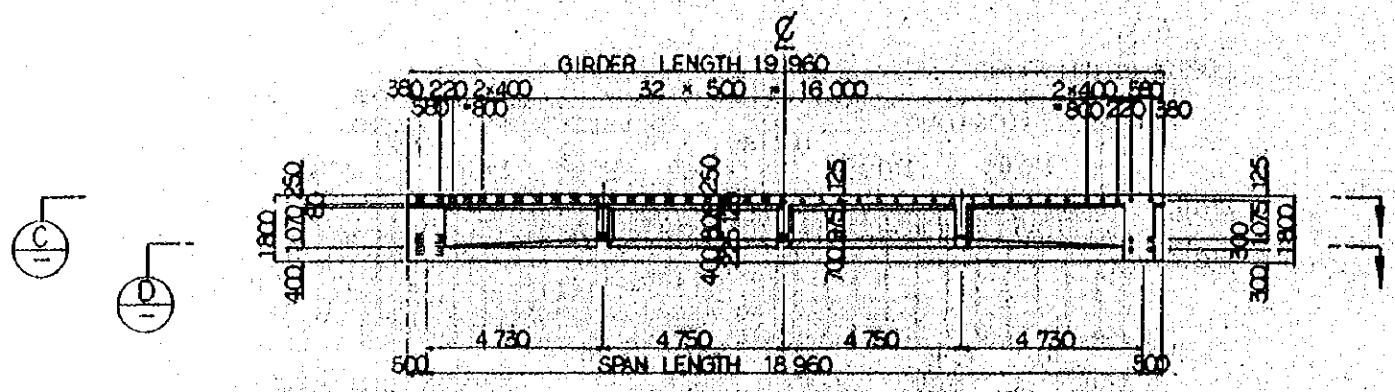

CROSS SECTION SCALE 1:50

SUPERSTRUCTURE MATERIAL SCHEDULE (B01 - PC01)

ITEM	TYPE	UNIT	QUANTITY
MAIN BEAM	CONCRETE CLASS A (16-400 <sup>kg/cm<sup>2</sup></sup> )	m <sup>3</sup>	52.2
	P.C. STRAND 12T12.7 (15-190 <sup>kg/mm<sup>2</sup></sup> )	kg	1960.4
	SHEATH P65	m	195.6
	FORMS	m <sup>2</sup>	229.3
	ANCHORING DEVICE FOR 12T12.7	EACH	20
	REINFORCING BAR 19	kg	—
	REINFORCING BAR 16	kg	557.2
	REINFORCING BAR 13	kg	3029.6
	REINFORCING BAR 10	kg	74.2
	TOTAL		3661.0
LATERAL JOINT	CONCRETE CLASS B (16-300 <sup>kg/cm<sup>2</sup></sup> )	m <sup>3</sup>	5.8
	P.C. BAR $\phi 23$ (15-110 <sup>kg/mm<sup>2</sup></sup> )	kg	692.1
	SHEATH $\phi 35$	m	203.0
	FORMS	m <sup>2</sup>	26.3
	ANCHOR PLATE/NUT FOR $\phi 23$	EACH	104
REINFORCING BAR 18	kg	757.4	
REINFORCING BAR 13	kg	1537.4	
REINFORCING BAR 10	kg	66.7	
TOTAL		2361.5	
SIDEWALK CONCRETE CLASS C (16-240 <sup>kg/cm<sup>2</sup></sup> )	m <sup>3</sup>	11.5	
BRIDGE RAILING CONCRETE	m <sup>3</sup>	3.9	
AND DUCT FORMS	m <sup>2</sup>	36.4	
MORTAR WITH SLOPE-PROTECTIVE MORTAR	m <sup>3</sup>	6.7	
DRAINAGE	EACH	4	
ELASTOMERIC BEARING PADS	FIX. FOR R = 140 ton	2	
	MOV. FOR R = 140 ton	2	

- NOTES:
- ALL DIMENSIONS ARE SHOWN IN MILLIMETERS UNLESS OTHERWISE INDICATED
  - MAIN BEAM SHALL BE PRECAST AND ALL THE OTHER CONCRETE EXCEPT R.C. COVER SHALL BE CAST IN PLACE
  - P.C. STRAND 12T 12.7 MEANS A GROUP OF 12 NO STRANDS FOR PRESTRESSED CONCRETE OF 12.7 MM DIAMETER EACH AND SHALL CONFORM TO JIS G 3538 SWPR7B 12T 12.7 OR EQUIVALENT
  - P.C. BAR SHALL CONFORM TO THE REQUIREMENTS AS FOLLOWS:  
 MINIMUM ULTIMATE TENSILE STRENGTH : 190<sup>kg/mm<sup>2</sup></sup>  
 MINIMUM YIELD STRESS : 160<sup>kg/mm<sup>2</sup></sup>
  - THIS DRAWING SHALL BE APPLIED TO : B01 - PC03
  - DESIGN TRAIN LOAD : EQUIVALENT TO KS - 16

REPUBLIC OF INDONESIA  
 MINISTRY OF COMMUNICATIONS  
 DIRECTORATE GENERAL OF LAND TRANSPORT AND INLAND WATERWAYS

NEW RAILWAY LINE FOR CENGKARENGI AIRPORT CONSTRUCTION PROJECT

JAPAN INTERNATIONAL COOPERATION AGENCY (JICA)

REVISOR	DATE	REASON	DESIGNED	CHECKED	REVISED	SUBMITTED
B	1 AUG '84		H.Y.A.	K.A.	K.M.	M.L.
A	15 FEB '84		H.Y.A.	A.O.	K.A.	K.N.

P.C. GIRDER  
 PC 01  
 GENERAL VIEW

PACKAGE : I CIVIL AND ARCHITECTURAL WORK  
 SCALE : AS NOTED  
 DRAWING NO : CS - 021

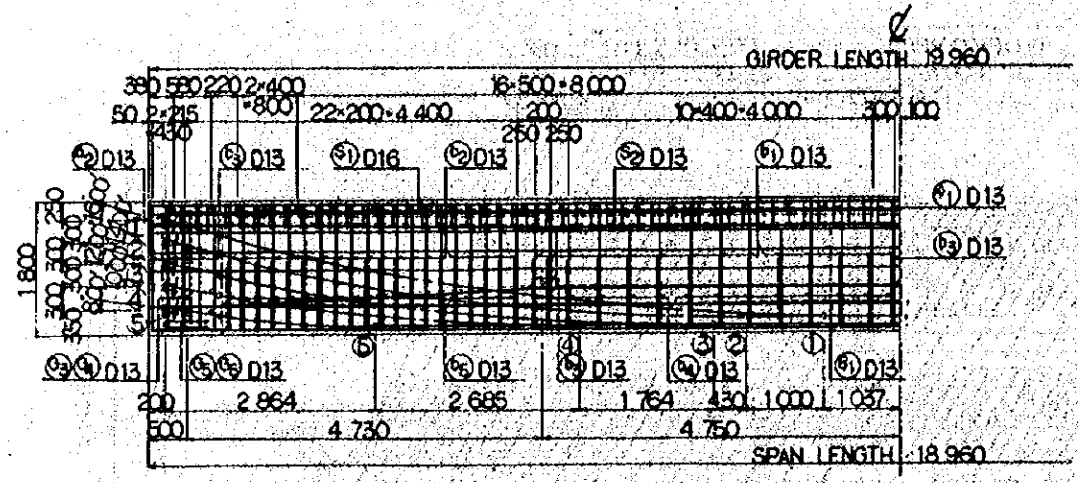

SIDE VIEW SCALE 1:50

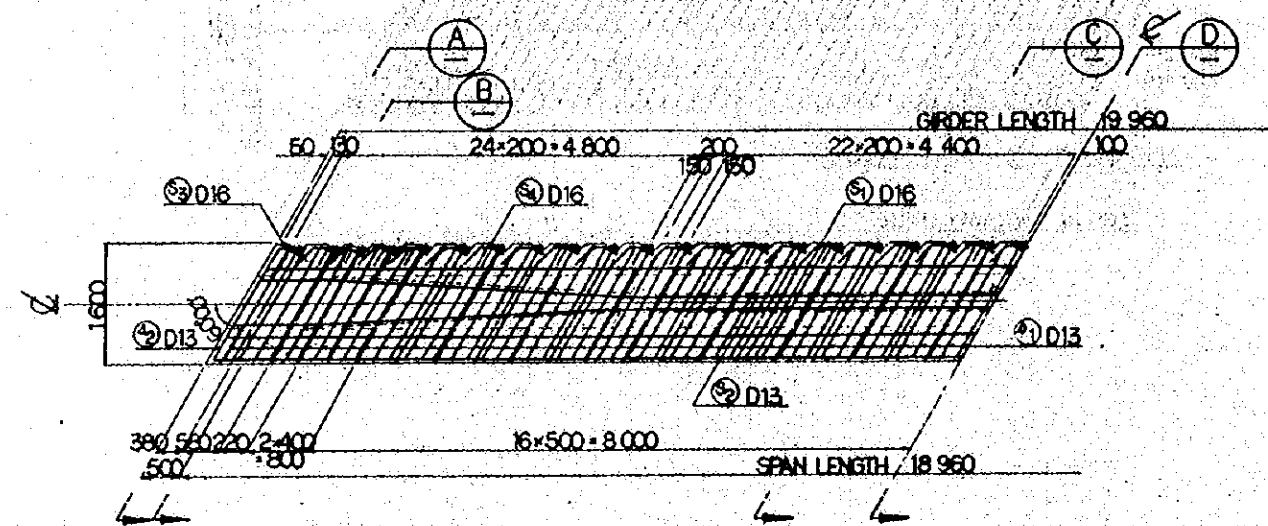

PLAN SCALE 1:50

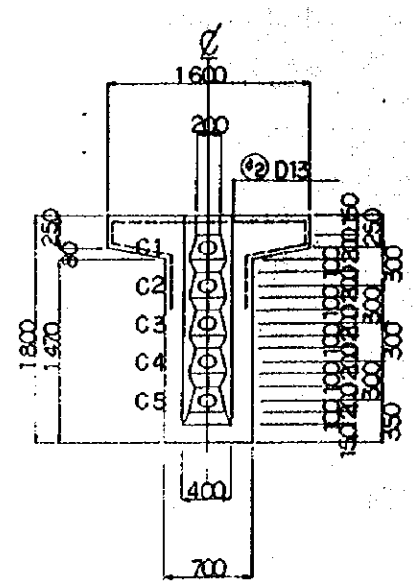

SECTION A

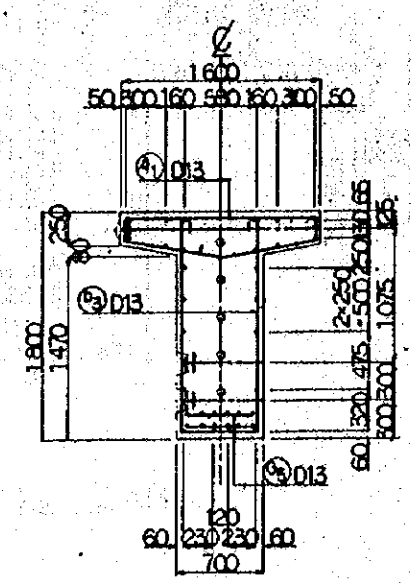

SECTION B

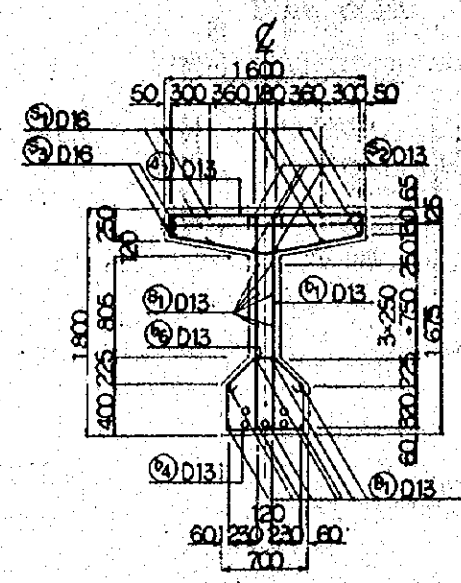

SECTION C

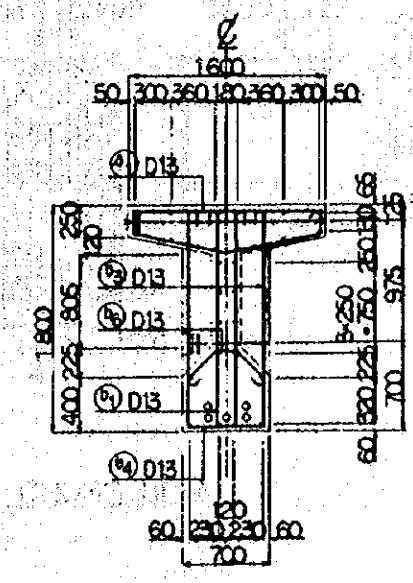

SECTION D

CROSS SECTION SCALE 1:30

BENDING SCHEDULE OF PC CABLES

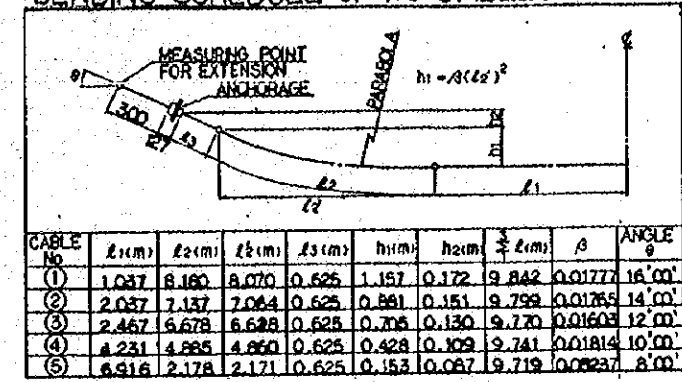

SCHEDULE OF PC BAR

SLAB	(mm)
A	4.977
CROSS BEAM	(mm)
A	2.938
B	3.383

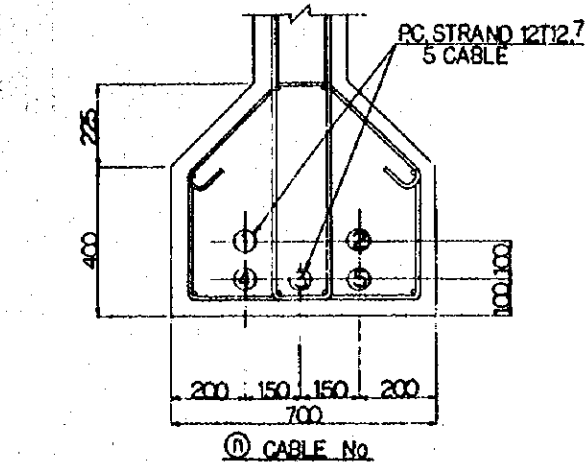

ARRANGEMENT OF PC CABLE SCALE 1:10

- NOTES:
- ALL DIMENSIONS ARE SHOWN IN MILLIMETRES UNLESS OTHERWISE INDICATED
  - REINFORCEMENT OF ANCHORAGE AND RECESS DIMENSION ARE EXAMPLES AND THESE SHALL BE REVIEWED AND, IF NECESSARY, BE ADJUSTED ACCORDING TO THE MANUFACTURER'S INSTRUCTIONS FOR THE SELECTED PRESTRESSING SYSTEM
  - JACKING LOAD INCLUDE FRICTION IN THE JACK AND ANCHORAGE. EXTENSION SHOWS TOTAL VALUE OF THOSE AT BOTH ENDS MEASURED AT THE POINT 30CM OUTSIDE FROM ANCHORAGE SURFACE. AFTER THE PRESTRESSING SYSTEM IS DETERMINED THESE VALUES SHALL BE REVIEWED ALONG WITH THE OTHER ASSUMED FACTORS AND, IF NECESSARY, BE ADJUSTED ACCORDING TO THE MANUFACTURER'S INSTRUCTIONS. INITIAL STRESS DO NOT INCLUDE OTHER FACTORS THAN FRICTION LOSSES.
  - TENSIONING SEQUENCE OF LATERAL PC BARS SHALL BE AT EVERY OTHER BAR

REPUBLIC OF INDONESIA  
 MINISTRY OF COMMUNICATIONS  
 DIRECTORATE GENERAL OF LAND TRANSPORT AND INLAND WATERWAYS

NEW RAILWAY LINE FOR CENGKARENG AIRPORT  
 CONSTRUCTION PROJECT

JAPAN INTERNATIONAL COOPERATION AGENCY (JICA)

B	1 AUG '84	MYAO	KA	KM	AK
A	15 FEB '84	MYAO	KA	KM	AK

REVISIONS DATE DESIGNED DRAWN CHECKED REVIEWED SUBMITTED

PC GIRDER  
 PC 01  
 PC CABLE AND REINF BAR  
 ARRANGEMENT OF MAIN BEAM

PACKAGE: I CIVIL AND ARCHITECTURAL WORK  
 SCALE: AS NOTED DRAWING NO: CS-022







NOTES:

1. ALL DIMENSIONS ARE SHOWN IN MILLIMETERS UNLESS OTHERWISE INDICATED
2. MAIN BEAM SHALL BE PRECAST AND ALL THE OTHER CONCRETE EXCEPT R.C. COVER SHALL BE CAST IN PLACE
3. P.C. STRAND 12T 15.2 MEANS A GROUP OF 12 NO STRANDS FOR PRESTRESSED CONCRETE OF 15.2MM DIAMETER EACH AND SHALL CONFORM TO JIS G 3536 SWPR7A 12T 15.2 OR EQUIVALENT
4. P.C. BAR SHALL CONFORM TO THE REQUIREMENTS AS FOLLOWS:  
 MINIMUM ULTIMATE TENSILE STRENGTH:  $165 \text{ kg/mm}^2$   
 MINIMUM YIELD STRESS:  $140 \text{ kg/mm}^2$
5. THIS DRAWING SHALL BE APPLIED TO:  
 : B06 - PC19
6. DESIGN TRAIN LOAD: EQUIVALENT TO  
 KS - 16

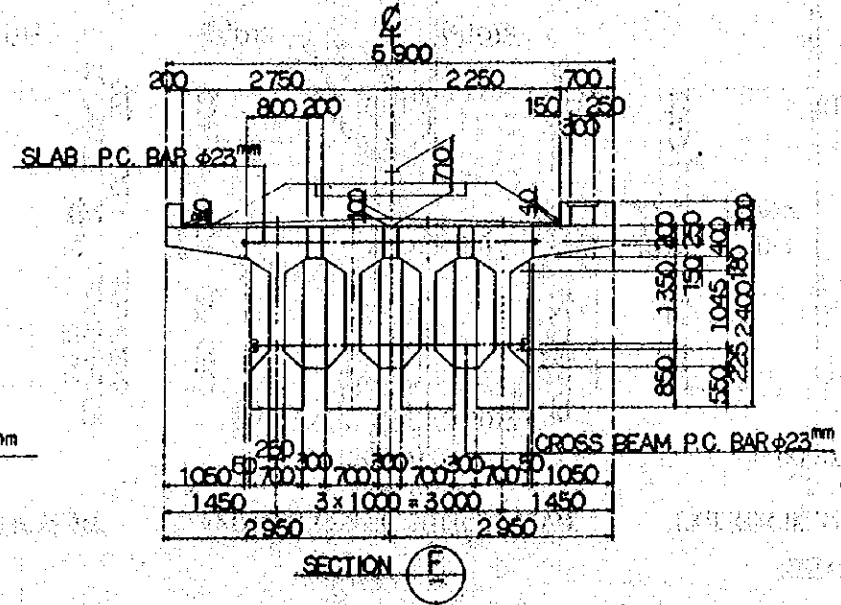
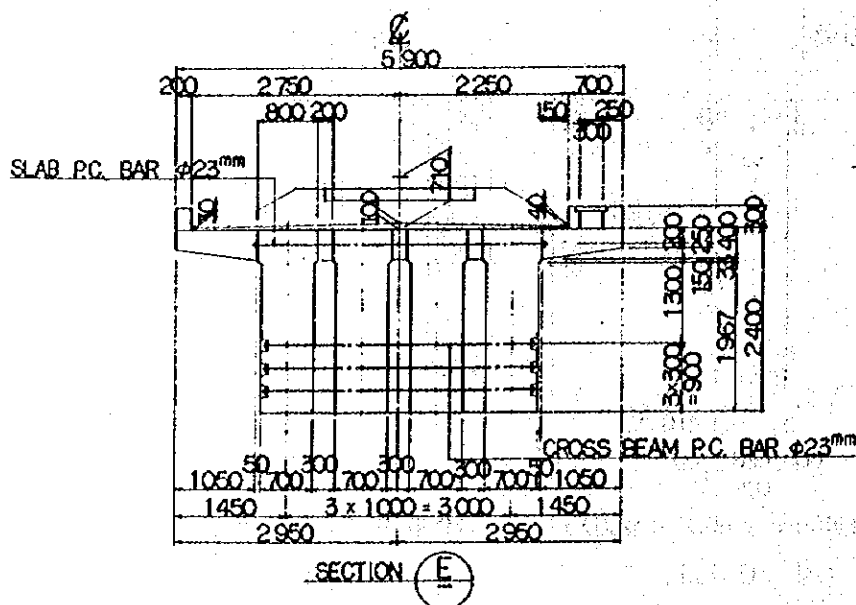
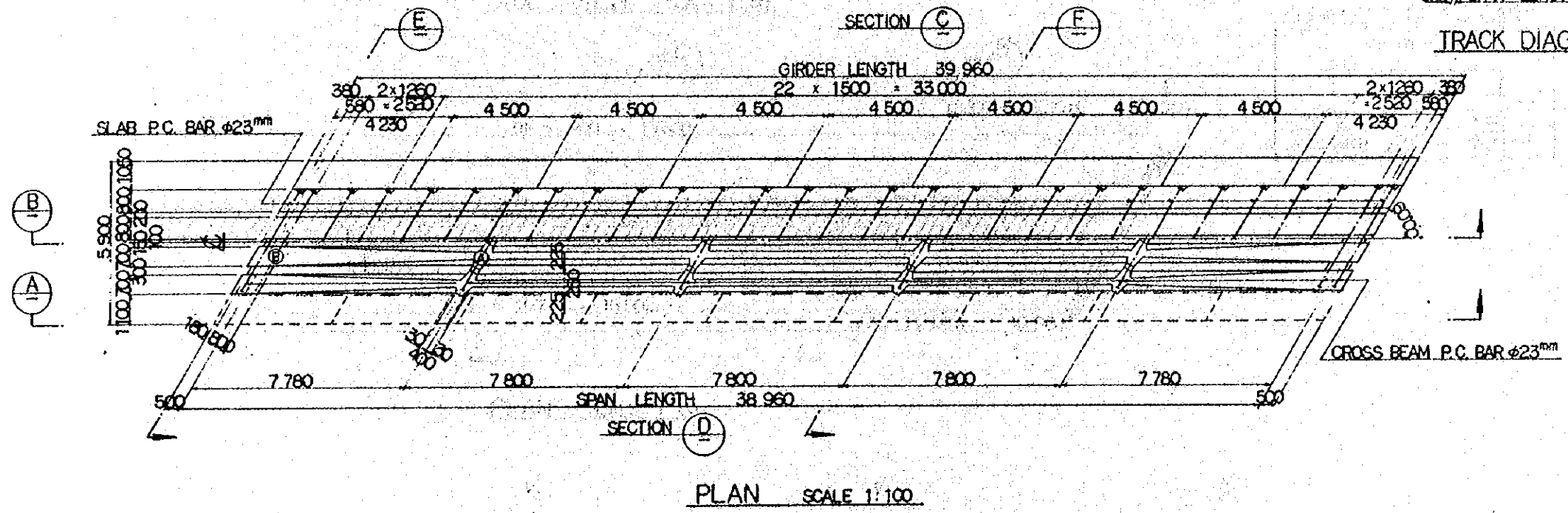
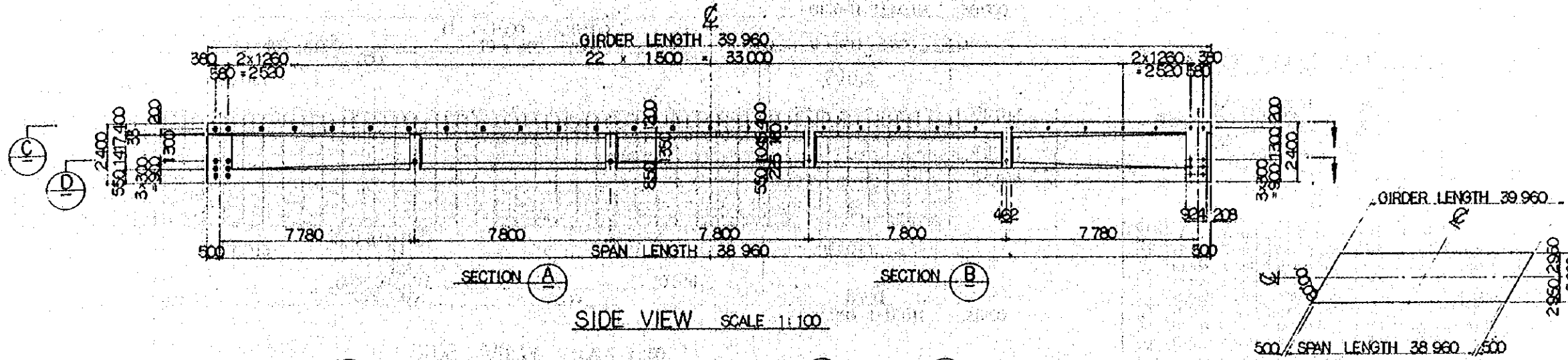

CROSS SECTION SCALE 1:50

SUPERSTRUCTURE MATERIAL SCHEDULE (B01-PC02)

ITEM	TYPE	UNIT	QUANTITY
MAIN BEAM	CONCRETE CLASS A ( $16-400 \text{ kg/cm}^2$ )	$\text{m}^3$	211.3
	P.C. STRAND 12T 15.2 ( $15-165 \text{ kg/cm}^2$ )	kg	15,233.9
	SHEATH $\phi 7.5$	m	1,102.0
	FORMS	$\text{m}^2$	968.3
	ANCHORING DEVICE FOR 12 T 15.2	EACH	56
	REINFORCING BAR		
	19	kg	2,869.9
	18	"	"
	13	"	10,581.2
	10	"	69.6
TOTAL			13,521.3
LATERAL JOINT	CONCRETE CLASS B ( $16-300 \text{ kg/cm}^2$ )	$\text{m}^3$	15.3
	P.C. BAR $\phi 23$ ( $15-110 \text{ kg/cm}^2$ )	kg	662.5
	SHEATH $\phi 3.5$	m	195.2
	FORMS	$\text{m}^2$	46.0
	ANCHOR PLATE, NUT FOR $\phi 23$	EACH	90
REINFORCING BAR	16	kg	1,423.6
	13	"	1,978.6
	10	"	649.5
	TOTAL		4,051.7
SIDEWALK CONCRETE	CLASS C ( $16-240 \text{ kg/cm}^2$ )	$\text{m}^3$	27.3
BRIDGE RAILING AND DUCT	CONCRETE	$\text{m}^3$	7.8
FORMS	$\text{m}^2$	72.4	
MORTAR WITH SLOPE PROTECTIVE MORTAR DRAINAGE		$\text{m}^3$	13.4
ELASTOMERIC BEARING PADS	FIX. FOR R=190 ton	"	4
	MOV. FOR R=190 ton	"	4

REPUBLIC OF INDONESIA  
 MINISTRY OF COMMUNICATIONS  
 DIRECTORATE GENERAL OF LAND TRANSPORT AND INLAND WATERWAYS

NEW RAILWAY LINE FOR CENKARENG AIRPORT CONSTRUCTION PROJECT

JAPAN INTERNATIONAL COOPERATION AGENCY (JICA)

B	1 AUG '84	M.Y.	T.O.	K.A.	K.M.	K.
A	15 FEB '84	M.Y.	A.O.	K.A.	K.M.	K.

REVISIONS: DATE, DESIGNED, DRAWN, CHECKED, REVIEWED, SUBMITTED

P.C. GIRDER  
 PC 02  
 GENERAL VIEW

PACKAGE: I CIVIL AND ARCHITECTURAL WORK  
 SCALE: AS NOTED  
 DRAWING NO: CS - 025

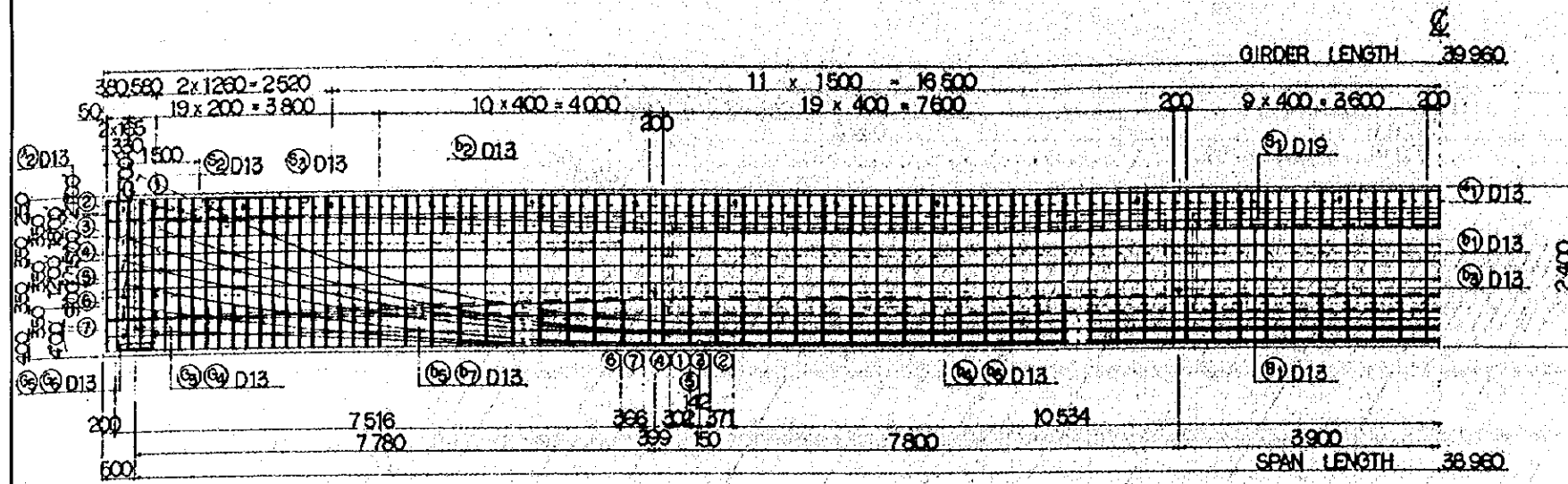

SIDE VIEW SCALE 1:50

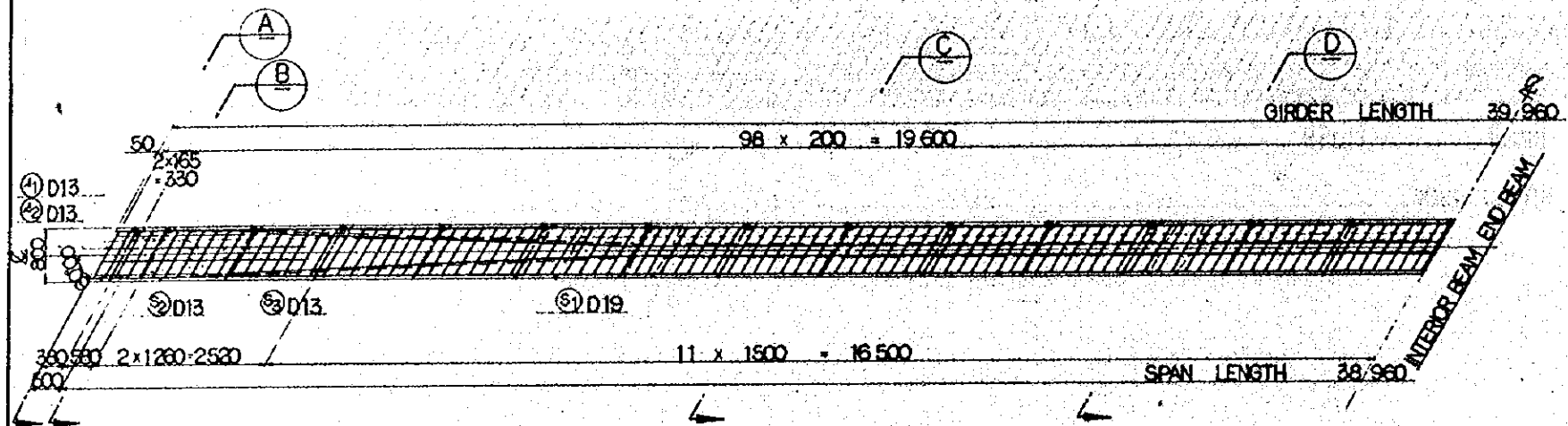

PLAN SCALE 1:50

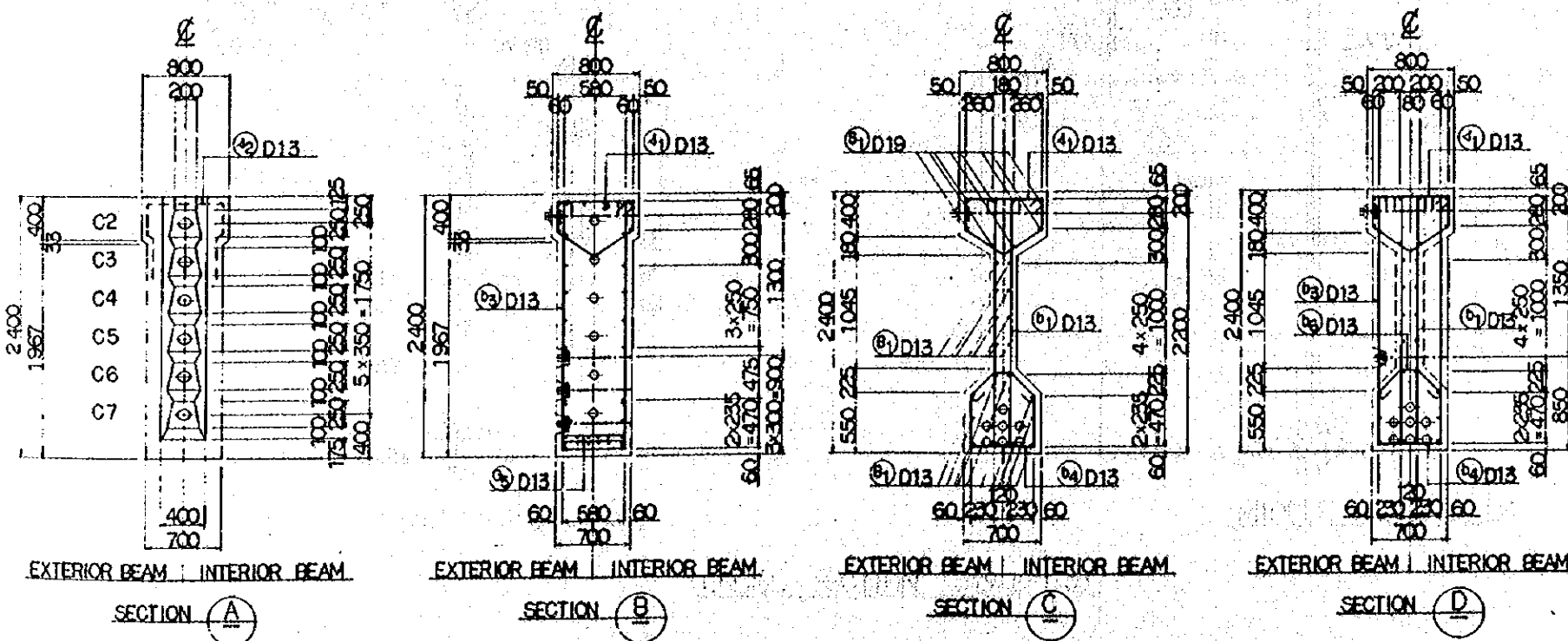

CROSS SECTION SCALE 1:30

BENDING SCHEDULE OF PC CABLES

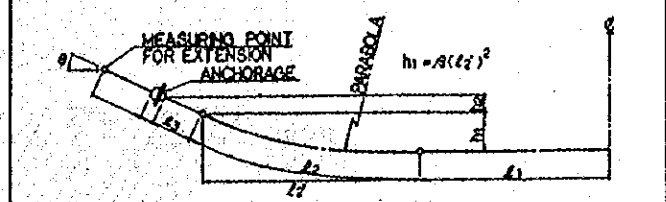

CABLE No.	L1(m)	L2(m)	L3(m)	L4(m)	h1(m)	h2(m)	L(m)	β	ANGLE θ
①	11.797	6.882	6.649	0.646	1.550	0.273	19.725	0.03507	26°00'
②	10.534	8.799	8.892	0.646	1.649	0.232	19.979	0.02234	21°00'
③	10.908	8.362	8.209	0.646	1.334	0.200	19.909	0.01979	16°00'
④	11.499	7.886	7.805	0.646	1.019	0.167	19.640	0.01762	15°00'
⑤	11.055	8.100	8.040	0.646	0.855	0.134	19.801	0.01322	12°00'
⑥	12.264	6.864	6.825	0.646	0.641	0.101	19.764	0.01160	9°00'
⑦	11.898	7.190	7.184	0.646	0.251	0.046	19.734	0.00467	4°00'

SCHEDULE OF PC BAR

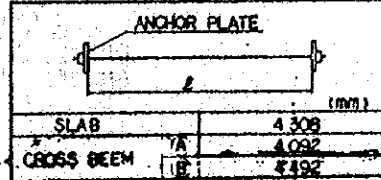

- NOTES:
1. ALL DIMENSIONS ARE SHOWN IN MILLIMETERS UNLESS OTHERWISE INDICATED
  2. REINFORCEMENT OF ANCHORAGE AND RECESS DIMENSION ARE EXAMPLES AND THESE SHALL BE REVIEWED AND, IF NECESSARY, BE ADJUSTED ACCORDING TO THE MANUFACTURER'S INSTRUCTIONS FOR THE SELECTED PRESTRESSING SYSTEM
  3. JACKING LOAD INCLUDE FRICTION IN THE JACK AND ANCHORAGE. EXTENSION SHOWS TOTAL VALUE OF THOSE AT BOTH ENDS MEASURED AT THE POINT 30CM OUTSIDE FROM ANCHORAGE SURFACE. AFTER THE PRESTRESSING SYSTEM IS DETERMINED THESE VALUES SHALL BE REVIEWED ALONG WITH THE OTHER ASSUMED FACTORS AND, IF NECESSARY, BE ADJUSTED ACCORDING TO THE MANUFACTURER'S INSTRUCTIONS. INITIAL STRESS DO NOT INCLUDE OTHER FACTORS THAN FRICTION LOSSES.
  4. TENSIONING SEQUENCE OF LATERAL PC BARS SHALL BE AT EVERY OTHER BAR

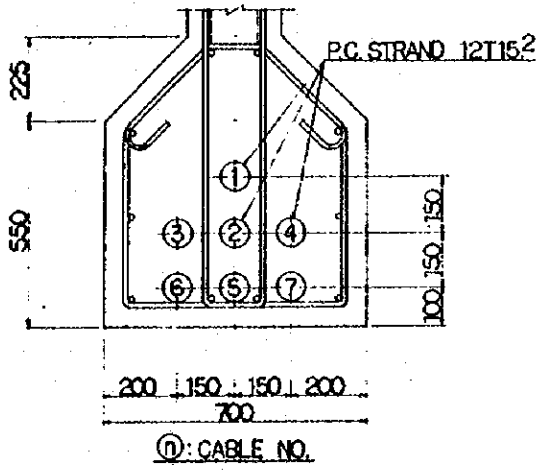

ARRANGEMENT OF PC CABLE SCALE 1:10

REPUBLIC OF INDONESIA  
 MINISTRY OF COMMUNICATIONS  
 DIRECTORATE GENERAL OF LAND TRANSPORT AND INLAND WATERWAYS

NEW RAILWAY LINE FOR CENGKARENG AIRPORT CONSTRUCTION PROJECT

JAPAN INTERNATIONAL COOPERATION AGENCY (JICA)

REVISIONS	DATE	DESIGNED	CHECKED	REVIEWED	SUBMITTED
B	1 AUG '84	MYAO	KAKM	AK	
A	15 FEB '84	MYAO	KAKM	AK	

P.C. GIRDER  
 PC 02  
 P.C. CABLE AND REINF. BAR  
 ARRANGEMENT OF MAIN BEAM

PACKAGE: 1 CIVIL AND ARCHITECTURAL WORK  
 SCALE: AS NOTED  
 DRAWING NO: CS-026





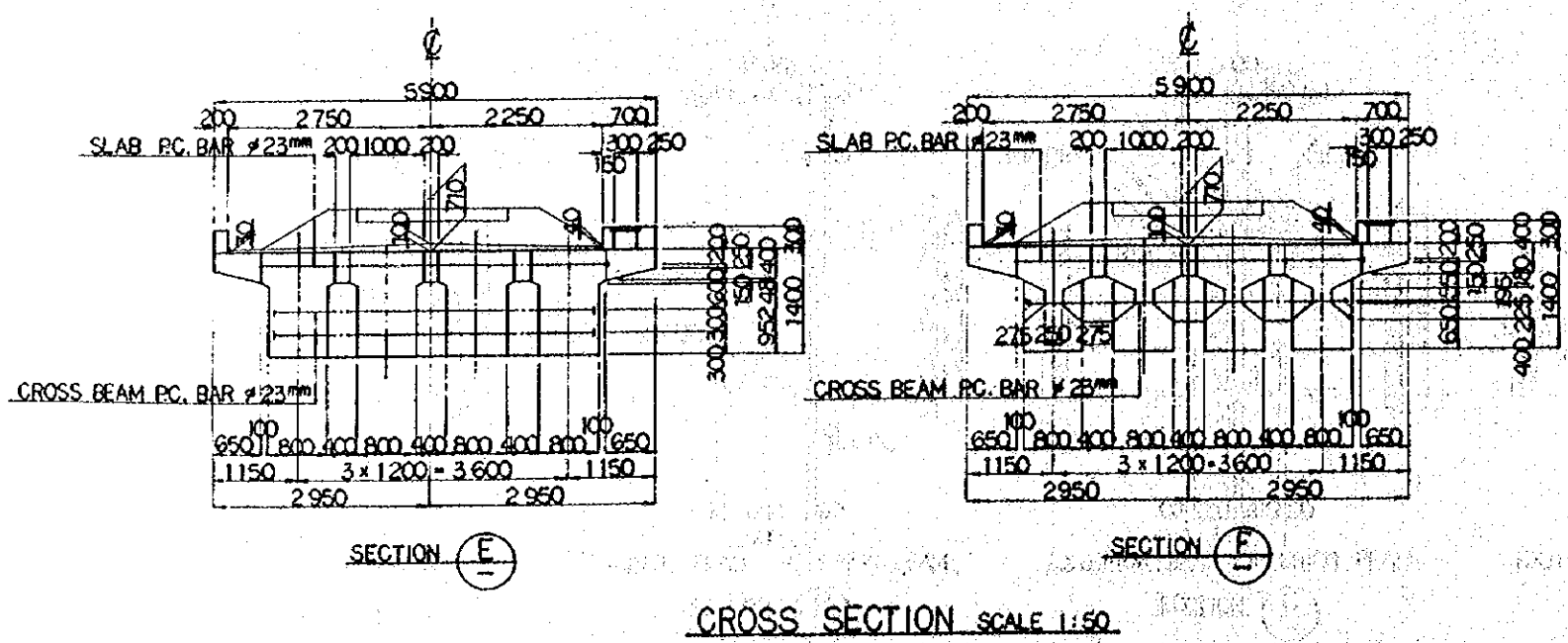
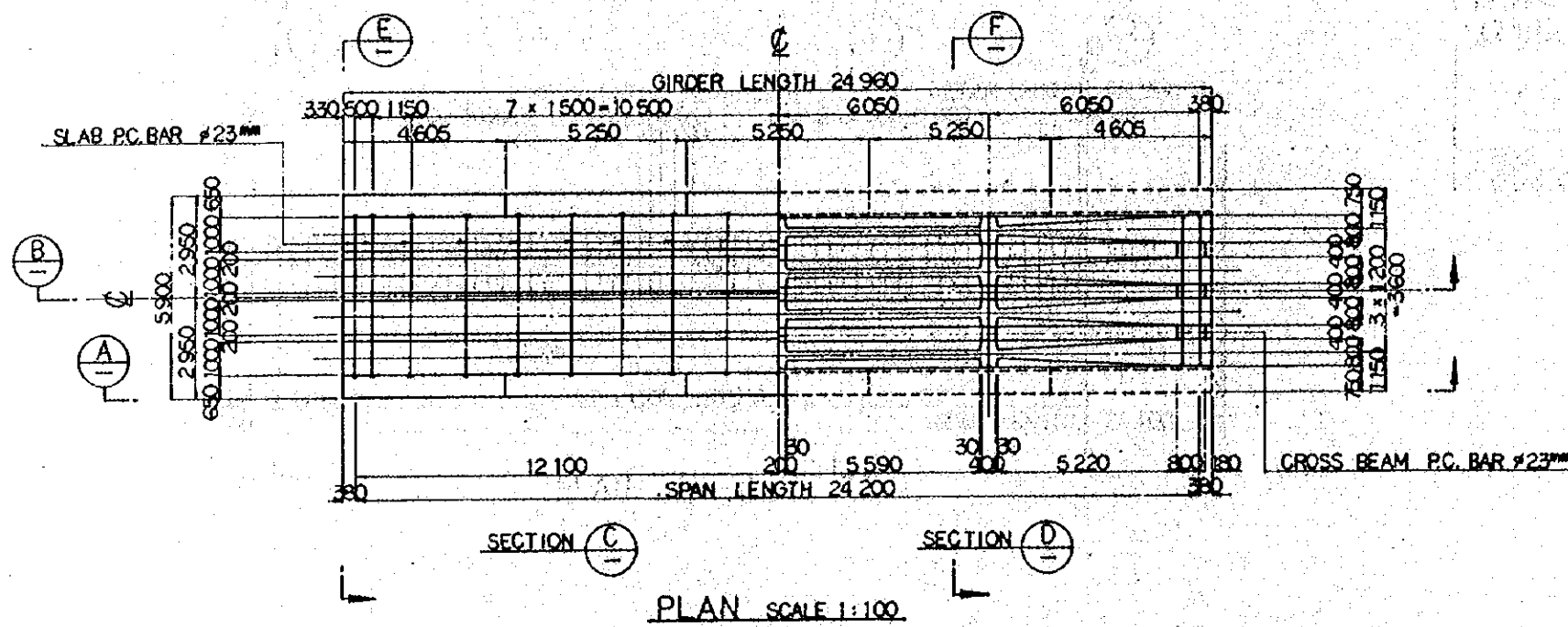
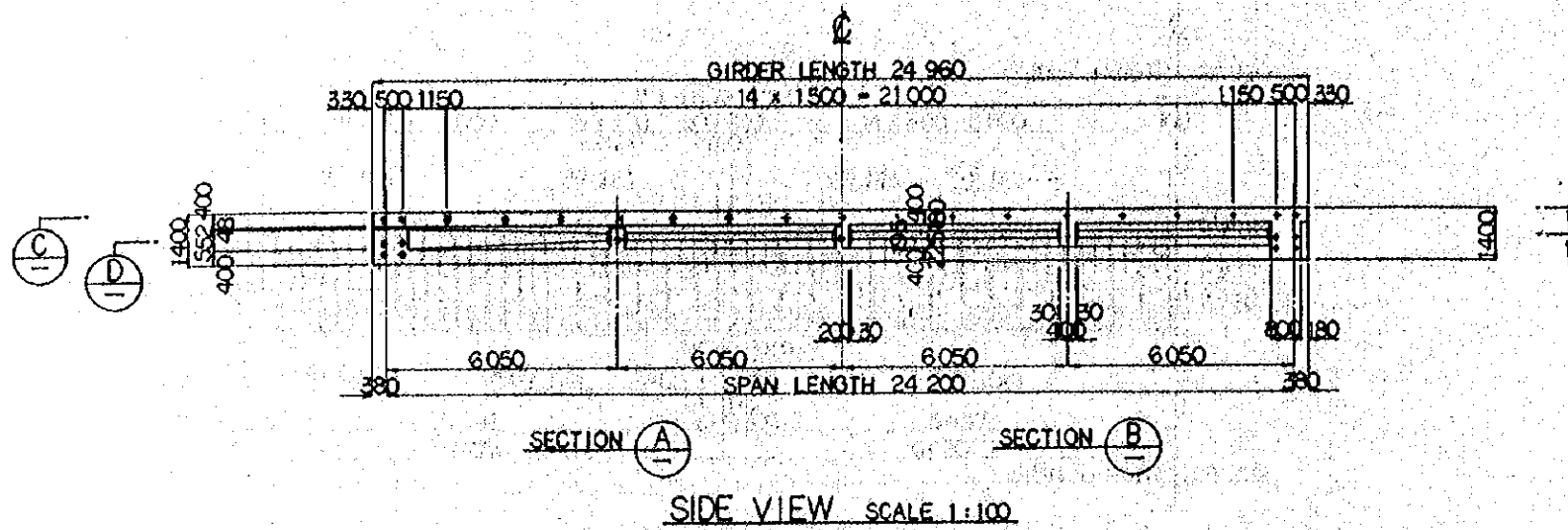

- NOTES:
- ALL DIMENSIONS ARE SHOWN IN MILLIMETERS UNLESS OTHERWISE INDICATED
  - MAIN BEAM SHALL BE PRECAST AND ALL THE OTHER CONCRETE EXCEPT R.C. COVER SHALL BE CAST IN PLACE
  - P.C. STRAND 12T 12.7 MEANS A GROUP OF 12 NO STRANDS FOR PRESTRESSED CONCRETE OF 12.7 MM DIAMETER EACH AND SHALL CONFORM TO JIS G 3536 SWPR7B 12T 12.7 OR EQUIVALENT
  - P.C. BAR SHALL CONFORM TO THE REQUIREMENTS AS FOLLOWS:  
 MINIMUM ULTIMATE TENSILE STRENGTH:  $190 \frac{kg}{mm^2}$   
 MINIMUM YIELD STRESS:  $160 \frac{kg}{mm^2}$
  - THIS DRAWING SHALL BE APPLIED TO:  
 : B03 - PC10  
 : B08 - PC22  
 : B08 - PC23  
 : B10 - PC27
  - DESIGN TRAIN LOAD: EQUIVALENT TO KS - 16

SUPERSTRUCTURE MATERIAL SCHEDULE (B02-PC04)

ITEM	TYPE	UNIT	QUANTITY
MAIN BEAM	CONCRETE CLASS A ( $f_c = 400 \frac{kg}{cm^2}$ )	m <sup>3</sup>	106.7
	P.C. STRAND 12T12.7 ( $f_s = 190 \frac{kg}{mm^2}$ )	kg	5,814.6
	SHEATH $\phi 65$	m	588.6
	FORMS	m <sup>2</sup>	426.1
	ANCHORING DEVICE FOR 12T 12.7	EACH	48
	REINFORCING BAR	kg	1241.0
			5290.8
			46.4
	TOTAL		6578.2
	LATERAL JOINT	CONCRETE CLASS B ( $f_c = 300 \frac{kg}{cm^2}$ )	m <sup>3</sup>
P.C. BAR $\phi 23$ ( $f_s = 110 \frac{kg}{mm^2}$ )		kg	453.7
SHEATH $\phi 35$		m	133.8
FORMS		m <sup>2</sup>	26.1
ANCHOR PLATE NUT FOR $\phi 23$		EACH	60
REINFORCING BAR		kg	672.2
		940.1	
		395.7	
TOTAL		2008.0	
SIDEWALK CONCRETE CLASS C ( $f_c = 240 \frac{kg}{cm^2}$ )	m <sup>3</sup>	10.5	
BRIDGE RAILING AND DUCT CONCRETE	m <sup>3</sup>	4.9	
FORMS	m <sup>2</sup>	45.3	
MORTAR WITH SLOPE-PROTECTIVE MORTAR DRAINAGE	m <sup>3</sup>	8.4	
ELASTOMERIC BEARING PADS	EACH	4	
		4	
		4	

REPUBLIC OF INDONESIA  
 MINISTRY OF COMMUNICATIONS  
 DIRECTORATE GENERAL OF LAND TRANSPORT AND INLAND WATERWAYS

NEW RAILWAY LINE FOR CENKARENG AIRPORT CONSTRUCTION PROJECT

JAPAN INTERNATIONAL COOPERATION AGENCY (JICA)

REVISIONS	DATE	DESIGNED	DRAWN	CHECKED	REVIEWED	SUBMITTED
B	1 AUG '84	M.Y.A.O.	K.K.K.M.			
A	15 FEB '84	M.Y.A.O.	K.K.K.M.			

P.C. GIRDER  
 PC 04  
 GENERAL VIEW

PACKAGE: 1 CIVIL AND ARCHITECTURAL WORK

SCALE: AS NOTED DRAWING NO: CS-029

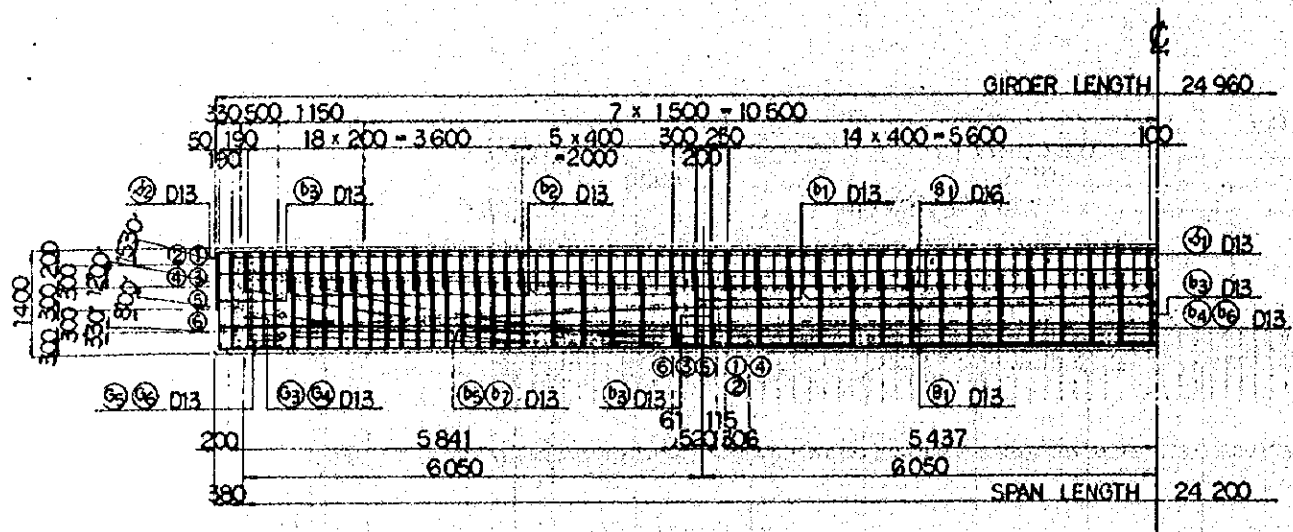

SIDE VIEW SCALE 1:50

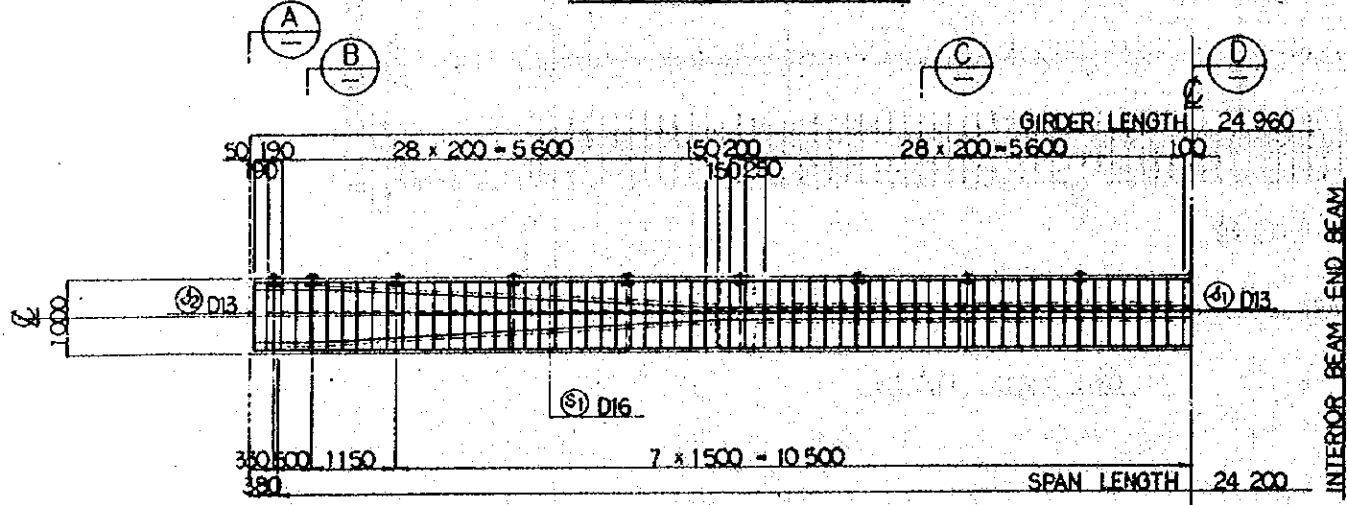

PLAN SCALE 1:50

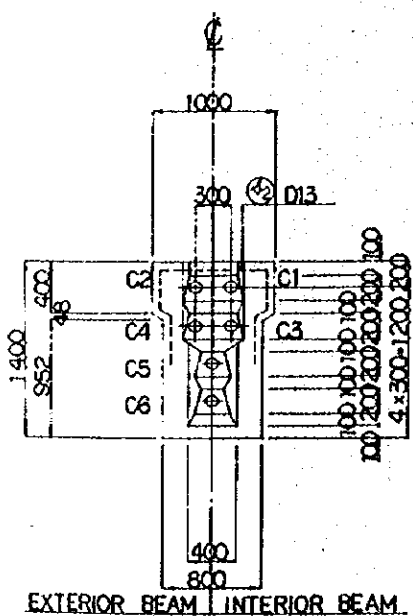

SECTION A

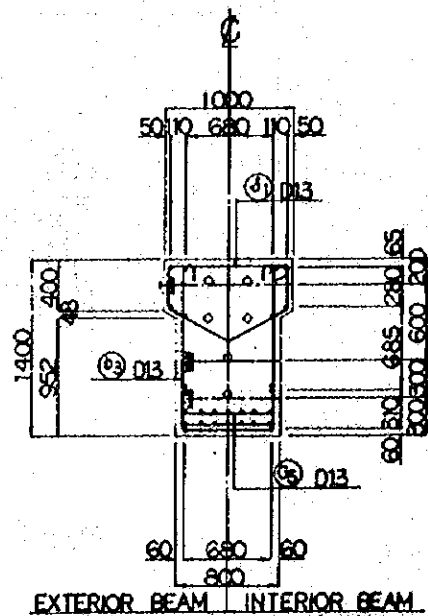

SECTION B

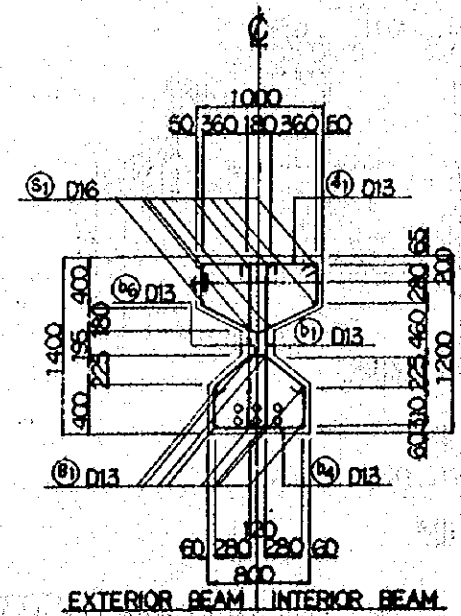

SECTION C

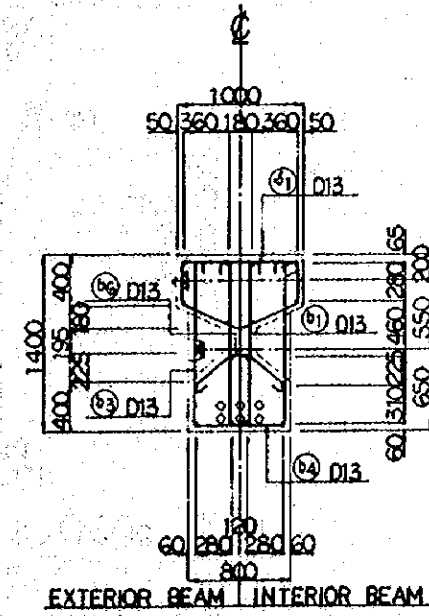

SECTION D

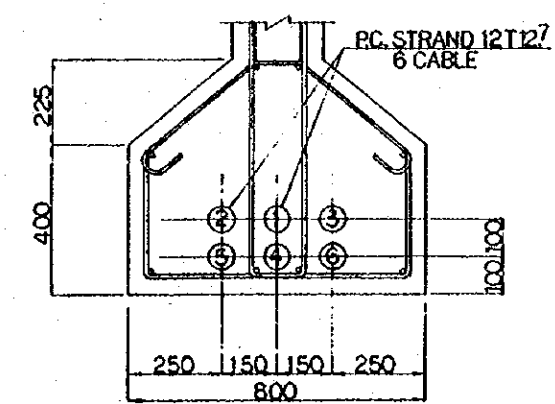

ARRANGEMENT OF PC CABLE SCALE 1:10

BENDING SCHEDULE OF PC CABLES

CABLE No	L1(m)	L2(m)	L2'(m)	L3(m)	h1(m)	h2(m)	Σ L(m)	β	ANGLE θ
①	5.743	5.937	5.863	0.625	0.813	0.167	12.305	0.02366	15°30'
②	5.743	5.937	5.863	0.625	0.813	0.167	12.305	0.02366	15°30'
③	6.378	6.256	6.217	0.625	0.555	0.130	12.259	0.02037	12°00'
④	5.437	6.204	6.158	0.625	0.655	0.130	12.266	0.01726	12°00'
⑤	5.858	5.748	5.729	0.625	0.403	0.097	12.231	0.01227	8°00'
⑥	6.439	5.148	5.142	0.625	0.157	0.039	12.209	0.00595	3°30'

SCHEDULE OF PC BAR

SLAB	(mm)
CROSS BEAM	4 600
	4 220

- NOTES:
- ALL DIMENSIONS ARE SHOWN IN MILLIMETERES UNLESS OTHERWISE INDICATED
  - REINFORCEMENT OF ANCHORAGE AND RECESS DIMENSION ARE EXAMPLES AND THESE SHALL BE REVIEWED AND, IF NECESSARY, BE ADJUSTED ACCORDING TO THE MANUFACTURER'S INSTRUCTIONS FOR THE SELECTED PRESTRESSING SYSTEM
  - JACKING LOAD INCLUDE FRICTION IN THE JACK AND ANCHORAGE. EXTENSION SHOWS TOTAL VALUE OF THOSE AT BOTH ENDS MEASURED AT THE POINT 30CM OUTSIDE FROM ANCHORAGE SURFACE. AFTER THE PRESTRESSING SYSTEM IS DETERMINED THESE VALUES SHALL BE REVIEWED ALONG WITH THE OTHER ASSUMED FACTORS AND, IF NECESSARY, BE ADJUSTED ACCORDING TO THE MANUFACTURER'S INSTRUCTIONS. INITIAL STRESS DO NOT INCLUDE OTHER FACTORS THAN FRICTION LOSSES.
  - TENSIONING SEQUENCE OF LATERAL PC BARS SHALL BE AT EVERY OTHER BAR

REPUBLIC OF INDONESIA  
 MINISTRY OF COMMUNICATIONS  
 DIRECTORATE GENERAL OF LAND TRANSPORT AND INLAND WATERWAYS

NEW RAILWAY LINE FOR CENGKARENG AIRPORT CONSTRUCTION PROJECT

JAPAN INTERNATIONAL COOPERATION AGENCY (JICA)

B	1 AUG '84	MY	AK	KM	AK
A	15 FEB '84	MY	AK	KM	AK

REVISIONS DATE DESIGNED DRAWN CHECKED EXTENDED SUBMITTED

P.C. GIRDER  
 PC 04  
 PC. CABLE AND REINF. BAR  
 ARRANGEMENT OF MAIN BEAM

PACKAGE: I CIVIL AND ARCHITECTURAL WORK  
 SCALE AS NOTED DRAWING NO. CS-030



NOTE:  
1. ALL DIMENSIONS ARE SHOWN IN MILLIMETERS UNLESS OTHERWISE INDICATED

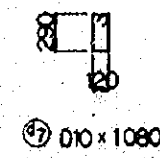
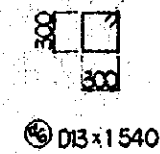
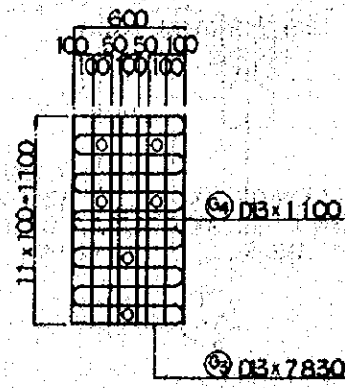
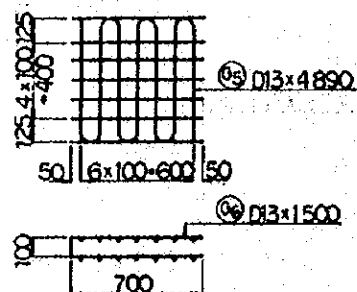
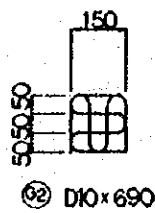
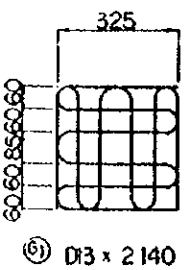
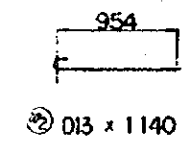
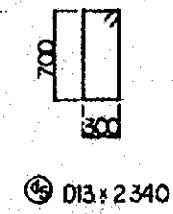
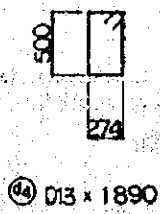
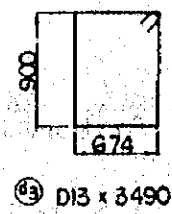
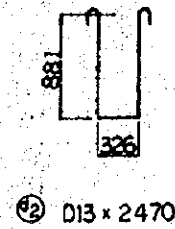
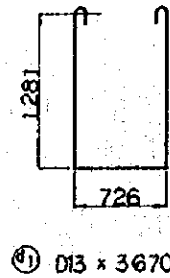
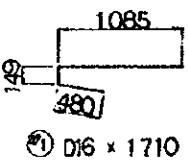
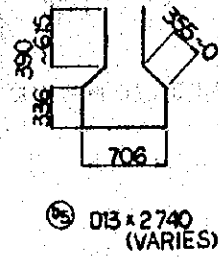
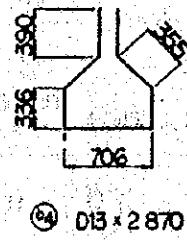
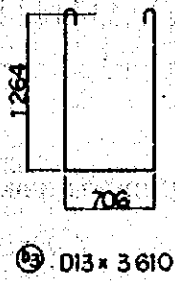
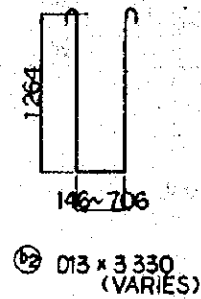
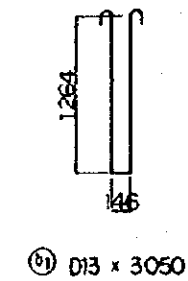
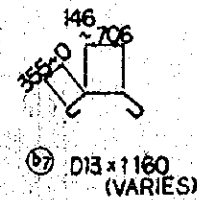
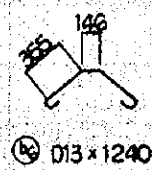
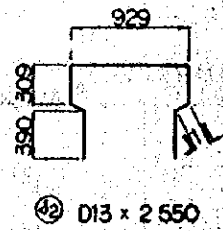
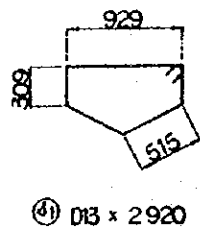
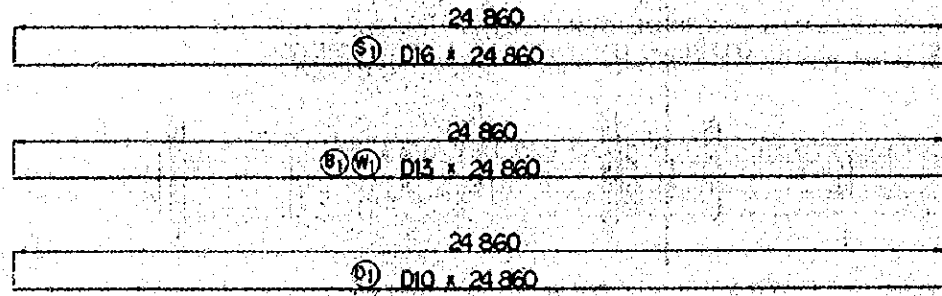

BAR SCHEDULE

REINFI NO	DIA (mm)	LENGTH (mm)	NUMBER / ONE BEAM EXTERIOR	NUMBER / ONE BEAM INTERIOR	TOTAL NUMBER	UWEIGHT (kg/m)	WEIGHT (kg)	
<b>MAIN BEAM</b>								
S 1	D16	24.860	8	8	32	1.560	1241.0	
A 1	D13	2.920	124	124	496	0.995	1441.1	
		2.550	2	2	8	.	20.3	
B 1	D13	24.860	8	8	32	0.995	791.5	
b 1	D13	3.050	34	34	136	0.995	412.7	
		3.330	42	42	168	.	556.6	
		3.610	16	16	64	.	229.9	
		2.870	34	34	136	.	388.4	
		2.740	42	42	168	.	458.0	
		1.240	34	34	136	.	167.8	
		1.160	42	42	168	.	193.9	
G 1	D13	2.140	24	24	96	0.995	204.4	
		D10	690	60	—	120	0.560	46.4
		D13	7.830	4	4	16	0.995	124.7
		.	1.100	32	32	128	.	140.1
		.	4.890	4	4	16	.	77.8
		.	1.500	14	14	56	.	83.6

WEIGHT OF BARS FOR MAIN BEAM

D16	1241.0 kg
D13	5290.8 kg
D10	46.4 kg
<b>TOTAL WEIGHT</b>	<b>6578.2 kg</b>

LATERAL JOINT

W 1	D13	24.860	—	—	16	0.995	395.8
W 1	D16	1.710	—	—	252	1.560	672.2
		D13	1.140	—	—	252	0.995
D 1	D10	24.860	—	—	12	0.560	167.1
d 1	D13	3.670	—	—	6	0.995	21.9
		2.470	—	—	9	.	22.1
		3.490	—	—	12	.	41.7
		1.890	—	—	18	.	33.8
		2.340	—	—	36	.	83.8
		1.540	—	—	36	.	55.2
		D10	1.080	—	—	378	0.560

WEIGHT OF BARS FOR LATERAL JOINT

D16	672.2 kg
D13	940.1 kg
D10	395.7 kg
<b>TOTAL WEIGHT</b>	<b>2008.0 kg</b>

TOTAL WEIGHT OF BARS

D16	1913.2 kg
D13	6230.9 kg
D10	442.1 kg
<b>TOTAL WEIGHT</b>	<b>8586.2 kg</b>

REPUBLIC OF INDONESIA  
MINISTRY OF COMMUNICATIONS  
DIRECTORATE GENERAL OF LAND TRANSPORT AND INLAND WATERWAYS

NEW RAILWAY LINE FOR CENGKARENG AIRPORT  
CONSTRUCTION PROJECT

JAPAN INTERNATIONAL COOPERATION AGENCY (JICA)

B	1AUG/84	MY	AO	KA	KM	AK
A	15FEB/84	MY	AO	KA	KM	AK
REVISION	DATE	DESIGNED	CHECKED	APPROVED	REVIEWED	SUBMITTED

P.C. GIRDER  
PC 04  
REINF. BAR SCHEDULE

PACKAGE: I CIVIL AND ARCHITECTURAL WORK  
SCALE: AS NOTED  
DRAWING No: CS - 032



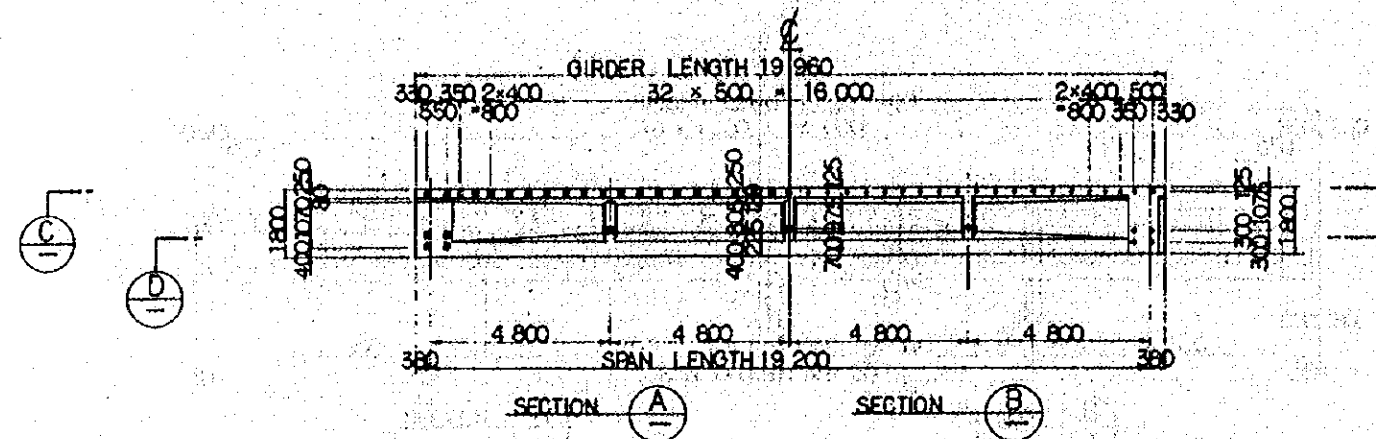

SIDE VIEW SCALE 1:100

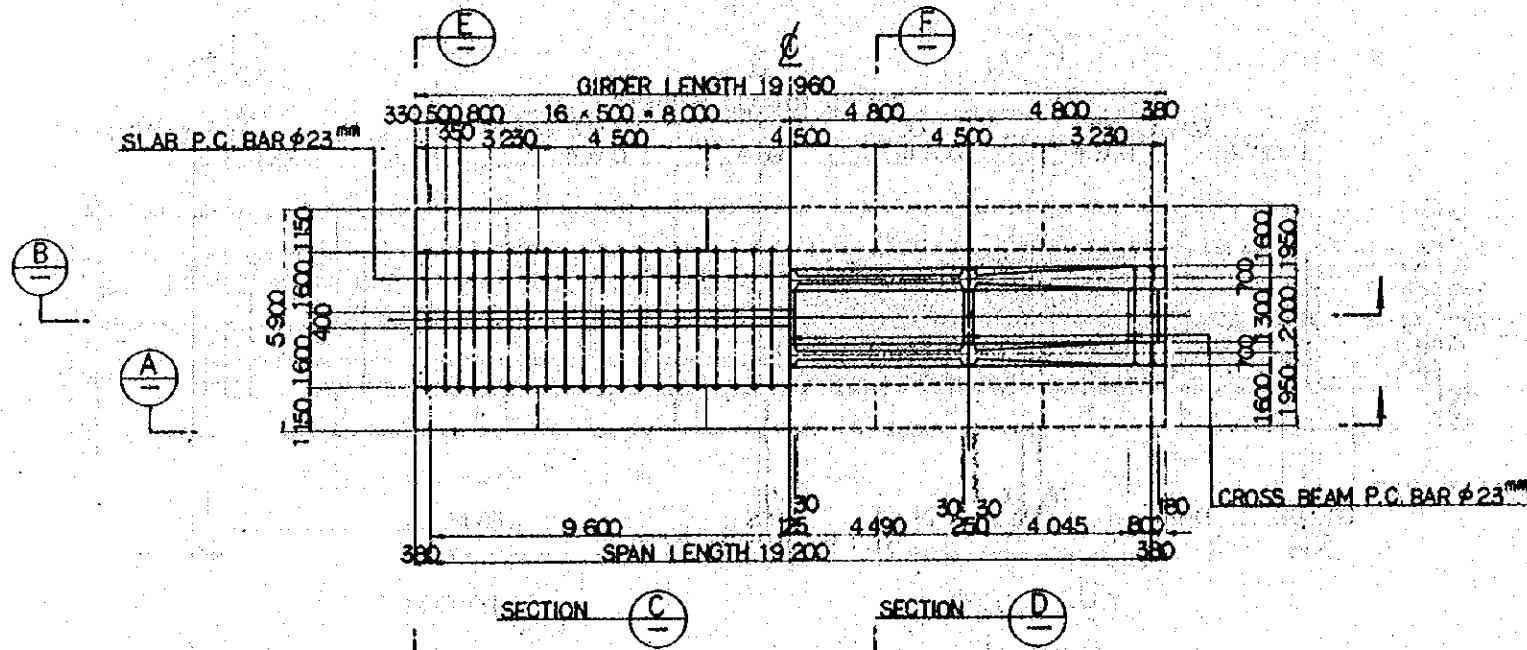

PLAN SCALE 1:100

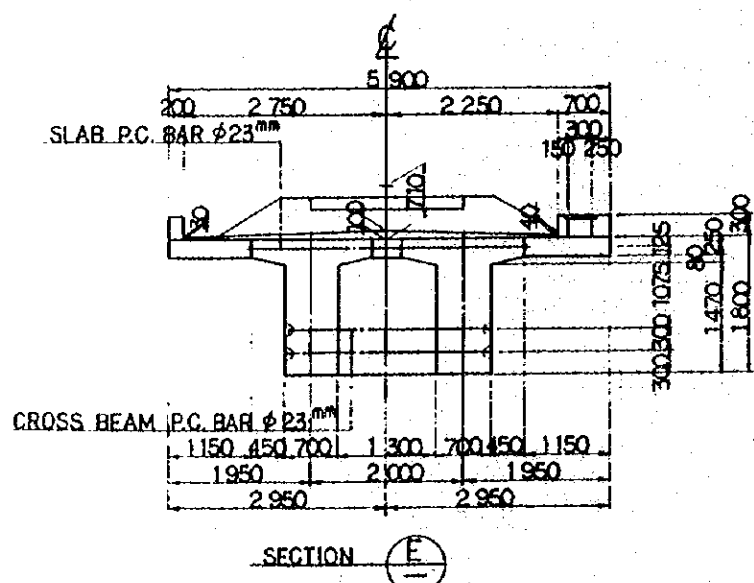

SECTION E

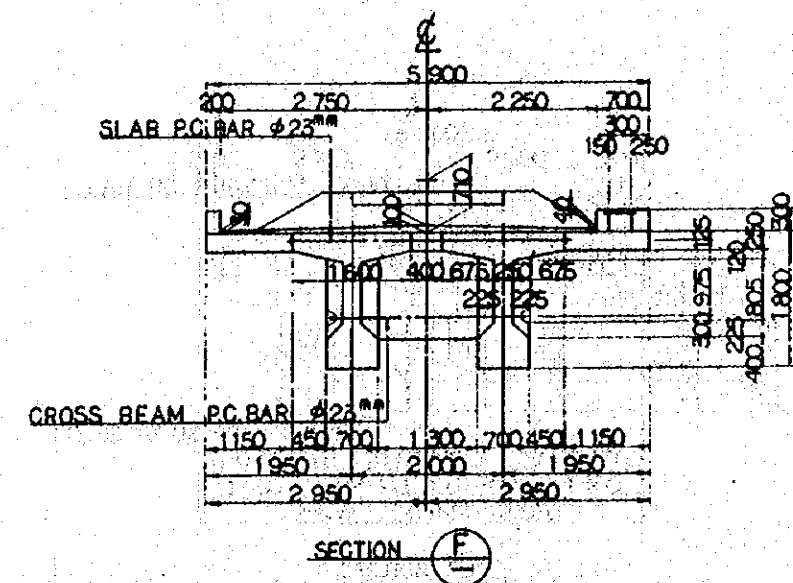

SECTION F

CROSS SECTION SCALE 1:50

- NOTES:
1. ALL DIMENSIONS ARE SHOWN IN MILLIMETERS UNLESS OTHERWISE INDICATED
  2. MAIN BEAM SHALL BE PRECAST AND ALL THE OTHER CONCRETE EXCEPT R.C. COVER SHALL BE CAST IN PLACE
  3. P.C. STRAND 12T 12.7 MEANS A GROUP OF 12 NO STRANDS FOR PRESTRESSED CONCRETE OF 12.7 MM DIAMETER EACH AND SHALL CONFORM TO JIS G 3536 SWPR7B 12T 12.7 OR EQUIVALENT
  4. P.C. BAR SHALL CONFORM TO THE REQUIREMENTS AS FOLLOWS:  
 MINIMUM ULTIMATE TENSILE STRENGTH : 190 kg/mm<sup>2</sup>  
 MINIMUM YIELD STRESS : 160 kg/mm<sup>2</sup>
  5. THIS DRAWING SHALL BE APPLIED TO  
 : B01 - PC01  
 : B03 - PC07  
 : B03 - PC08  
 : B03 - PC09  
 : B03 - PC11
  6. DESIGN TRAIN LOAD: EQUIVALENT TO  
 KS - 16

SUPERSTRUCTURE MATERIAL SCHEDULE (B03-PC05)

ITEM	TYPE	UNIT	QUANTITY
MAIN BEAM	CONCRETE CLASS A (f <sub>c</sub> = 400 kg/cm <sup>2</sup> )	m <sup>3</sup>	49.7
	P.C. STRAND 12T 12.7 (f <sub>s</sub> = 190 kg/mm <sup>2</sup> )	kg	1960.4
	SHEATH φ65 and φ70	m	195.5
	FORMS	m <sup>2</sup>	227.0
	ANCHORING DEVICE FOR 12 T 12.7	EACH	20
	REINFORCING BAR	kg	557.2
	16	•	3029.6
	13	•	74.2
	10	•	3661.0
	TOTAL	•	3661.0
LATERAL JOINT	CONCRETE CLASS B (f <sub>c</sub> = 300 kg/cm <sup>2</sup> )	m <sup>3</sup>	6.3
	P.C. BAR φ23 (f <sub>s</sub> = 110 kg/mm <sup>2</sup> )	kg	601.7
	SHEATH φ35	m	125.3
	FORMS	m <sup>2</sup>	27.0
	ANCHOR PLATE, NUT FOR φ23	EACH	104
REINFORCING BAR	kg	757.4	
16	•	1537.4	
13	•	66.7	
10	•	2361.5	
TOTAL	•	2361.5	
SIDEWALK CONCRETE	CLASS C (f <sub>c</sub> = 240 kg/cm <sup>2</sup> )	m <sup>3</sup>	11.5
BRIDGE RAILING AND DUCT CONCRETE	FORMS	m <sup>3</sup>	3.9
FORMS	m <sup>2</sup>	36.3	
MORTAR WITH SLOPE PROTECTIVE MORTAR DRAINAGE	m <sup>3</sup>	6.7	
ELASTOMERIC BEARING PADS	FIX. FOR R=140 (cm)	•	2
MOV. FOR R=140 (cm)	•	2	

REPUBLIC OF INDONESIA  
 MINISTRY OF COMMUNICATIONS  
 DIRECTORATE GENERAL OF LAND TRANSPORT AND INLAND WATERWAYS

NEW RAILWAY LINE FOR CENGKARENG AIRPORT CONSTRUCTION PROJECT

JAPAN INTERNATIONAL COOPERATION AGENCY (JICA)

REVISIONS	DATE	DESIGNED	DRAWN	CHECKED	REVIEWED	SUBMITTED
B	1 AUG 84	MYAO	K.A.H.M.	M.K.		
A	15 FEB 84	MYAO	K.A.H.M.	M.K.		

P.C. GIRDER  
 PC 05  
 GENERAL VIEW

PACKAGE: I CIVIL AND ARCHITECTURAL WORK

SCALE: AS NOTED DRAWING NO: CS - 033



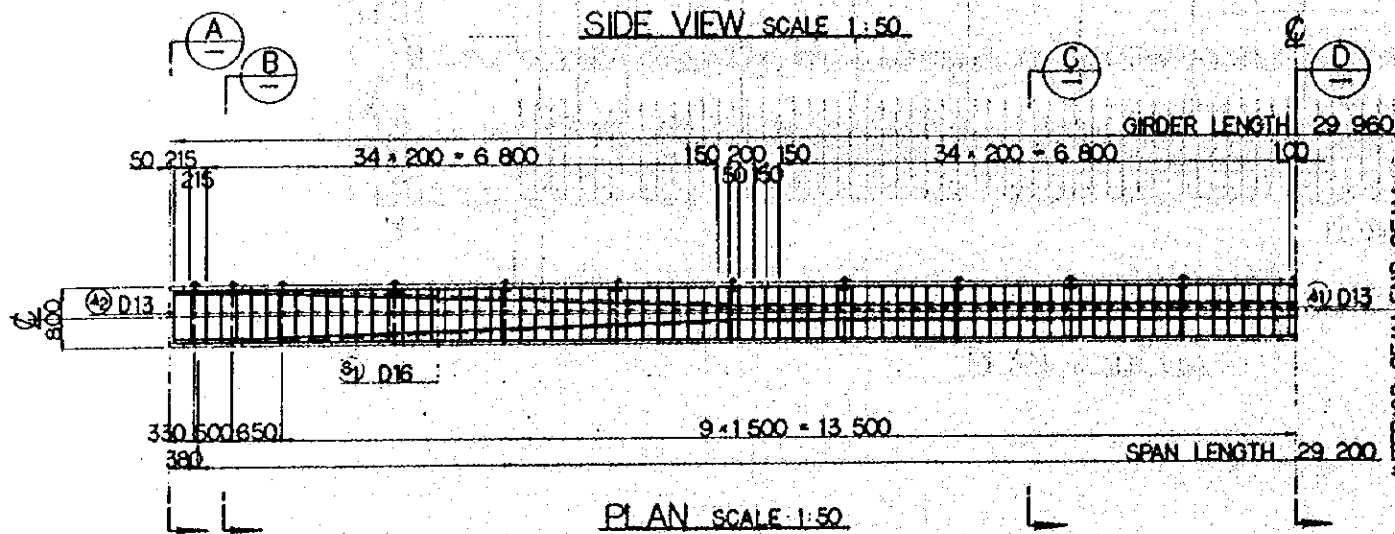
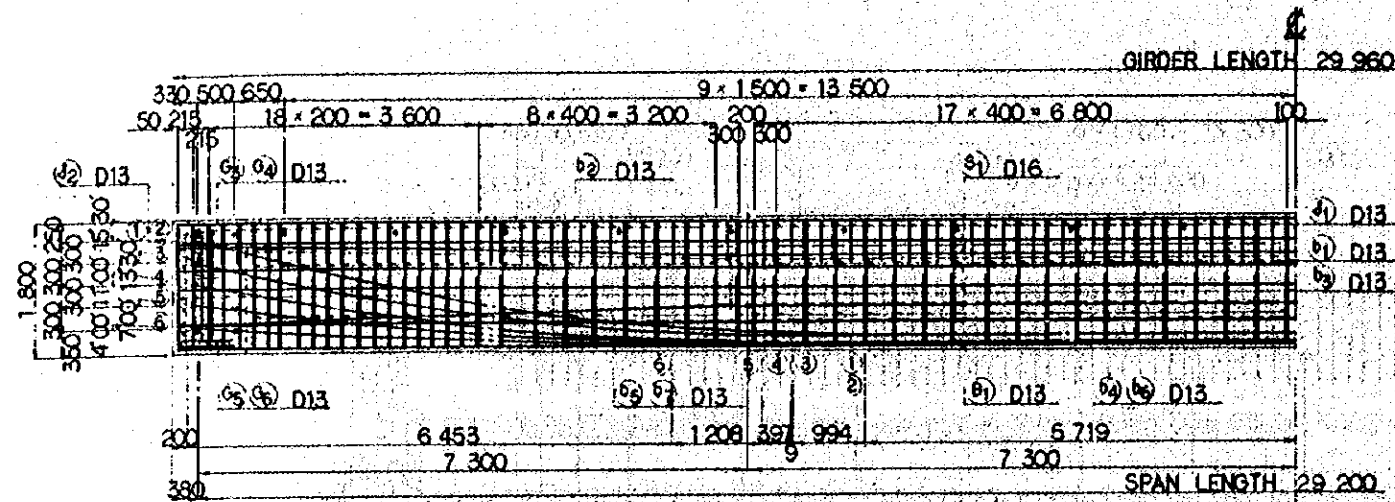

BENDING SCHEDULE OF PC CABLES

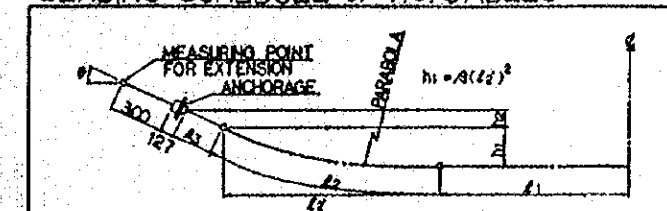

CABLE No	L1(m)	L2(m)	L3(m)	L4(m)	h1(m)	h2(m)	L(m)	β	ANGLE θ
①	5.719	8.493	8.287	0.625	1.163	0.167	14.887	0.0663	15° 30'
②	5.719	8.493	8.287	0.625	1.163	0.167	14.887	0.0663	15° 30'
③	6.713	7.454	7.385	0.625	0.887	0.146	14.794	0.0625	13° 30'
④	6.722	7.417	7.371	0.625	0.716	0.119	14.764	0.0319	11° 00'
⑤	7.119	6.987	6.967	0.625	0.459	0.082	14.731	0.0094	7° 30'
⑥	8.327	5.759	5.755	0.625	0.201	0.043	14.711	0.0009	4° 00'

SCHEDULE OF PC BAR

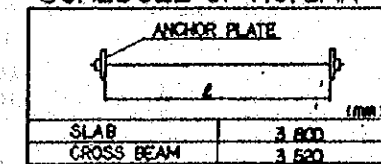

- NOTES:
- ALL DIMENSIONS ARE SHOWN IN MILLIMETERS UNLESS OTHERWISE INDICATED
  - REINFORCEMENT OF ANCHORAGE AND RECESS DIMENSION ARE EXAMPLES AND THESE SHALL BE REVIEWED AND, IF NECESSARY, BE ADJUSTED ACCORDING TO THE MANUFACTURER'S INSTRUCTIONS FOR THE SELECTED PRESTRESSING SYSTEM
  - JACKING LOAD INCLUDE FRICTION IN THE JACK AND ANCHORAGE. EXTENSION SHOWS TOTAL VALUE OF THOSE AT BOTH ENDS MEASURED AT THE POINT 30CM OUTSIDE FROM ANCHORAGE SURFACE. AFTER THE PRESTRESSING SYSTEM IS DETERMINED THESE VALUES SHALL BE REVIEWED ALONG WITH THE OTHER ASSUMED FACTORS AND, IF NECESSARY, BE ADJUSTED ACCORDING TO THE MANUFACTURER'S INSTRUCTIONS. INITIAL STRESS DO NOT INCLUDE OTHER FACTORS THAN FRICTION LOSSES.
  - TENSIONING SEQUENCE OF LATERAL PC BARS SHALL BE AT EVERY OTHER BAR

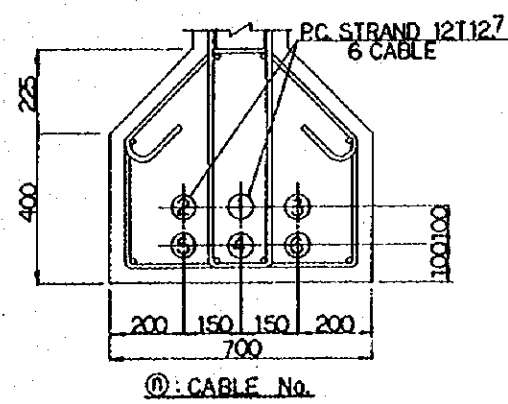
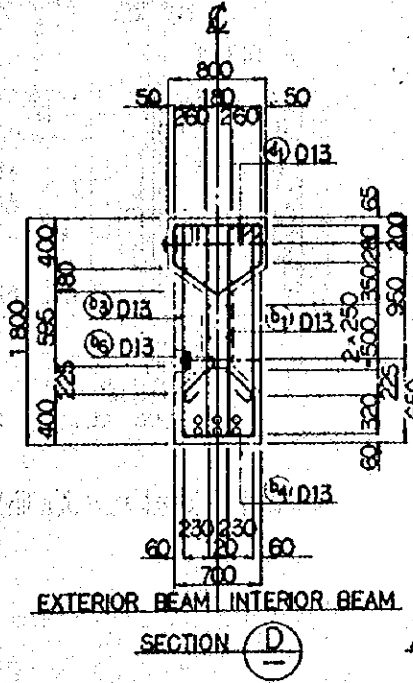
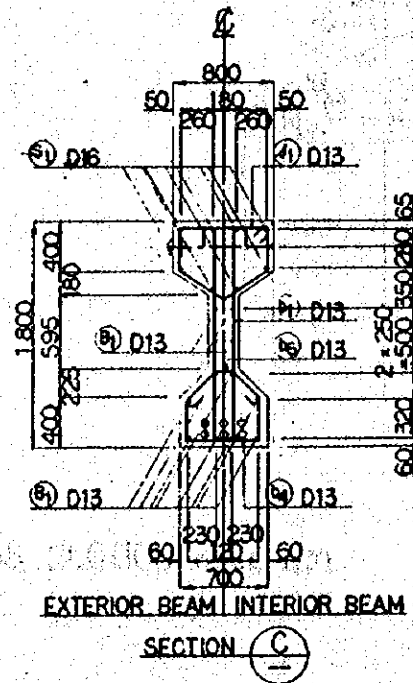
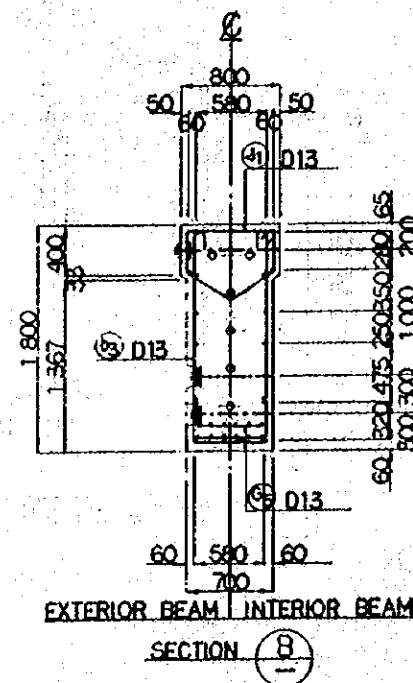
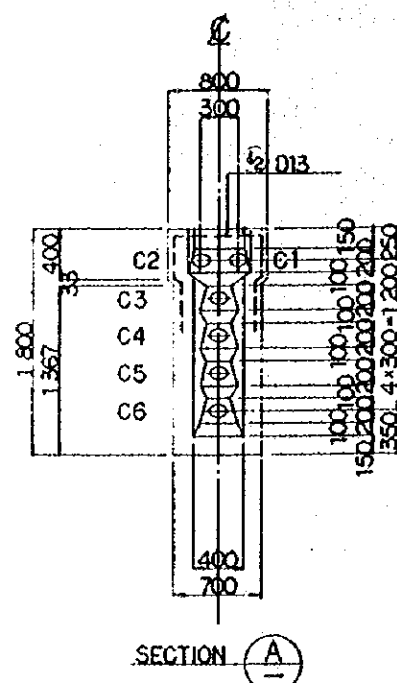

CROSS SECTION SCALE 1:30

ARRANGEMENT OF PC CABLE SCALE 1:10

REPUBLIC OF INDONESIA  
 MINISTRY OF COMMUNICATIONS  
 DIRECTORATE GENERAL OF LAND TRANSPORT AND INLAND WATERWAYS

NEW RAILWAY LINE FOR CENGKARENG AIRPORT CONSTRUCTION PROJECT

JAPAN INTERNATIONAL COOPERATION AGENCY (JICA)

B	1AUG84	NY	AD	KR	UM	mk
A	15FEB/81	NY	AD	KR	UM	mk

PC GIRDER  
 PC 06  
 PC CABLE AND REINF BAR  
 ARRANGEMENT OF MAIN BEAM

PACKAGE: 1 CIVIL AND ARCHITECTURAL WORK  
 SCALE: AS NOTED  
 DRAWING NO: CS - 035