

TYPICAL CROSS SECTION OF C-5  
 SCALE 1:600

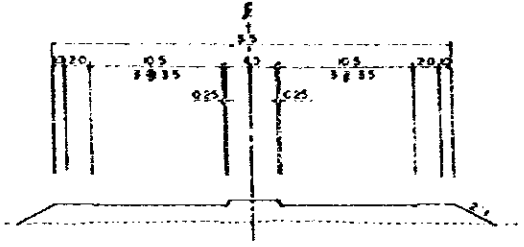

C-5 TAPER SECTION  
 SCALE 1:600

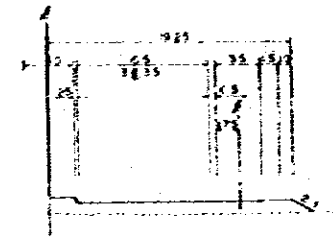

C-5 NOSE SECTION OF DECELERATION LANE  
 SCALE 1:600

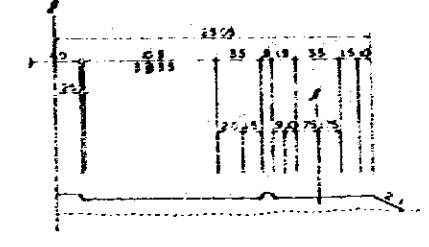

C-5 NOSE SECTION OF ACCELERATION LANE  
 SCALE 1:600

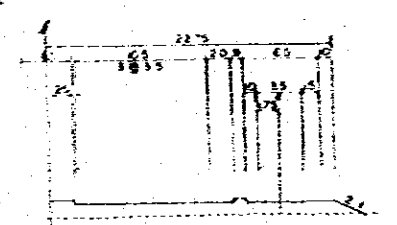

LOCATION MAP

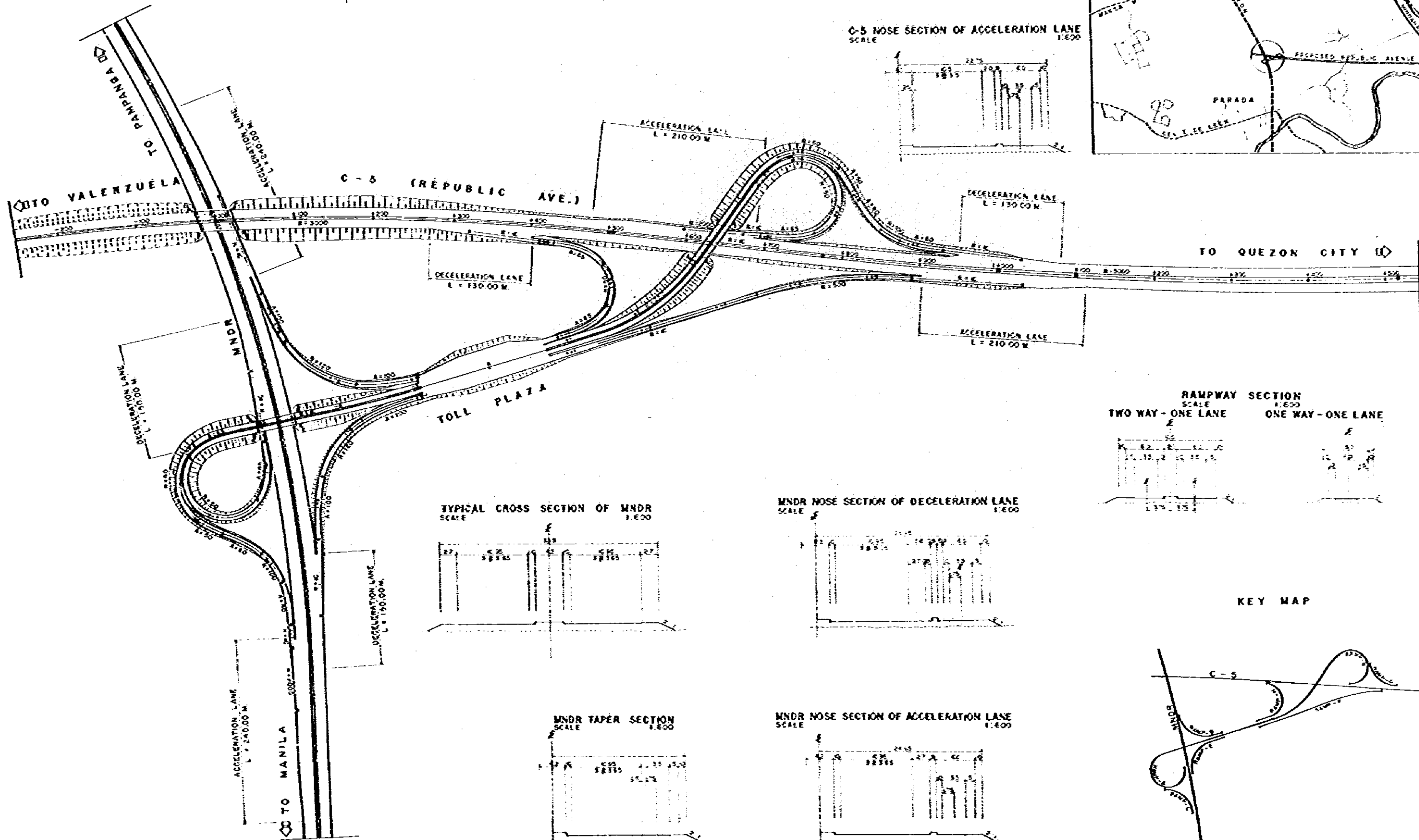
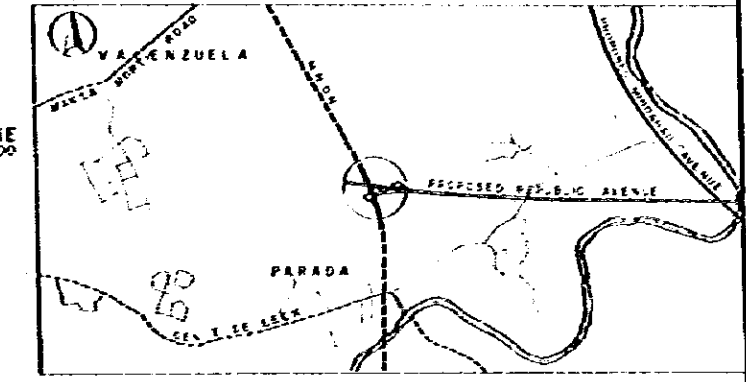

RAMPWAY SECTION  
 SCALE 1:600  
 TWO WAY - ONE LANE ONE WAY - ONE LANE

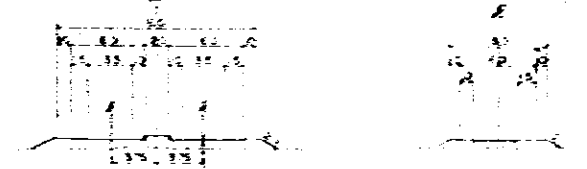

TYPICAL CROSS SECTION OF MNDR  
 SCALE 1:600

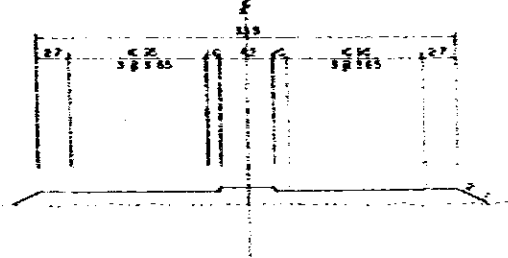

MNDR NOSE SECTION OF DECELERATION LANE  
 SCALE 1:600

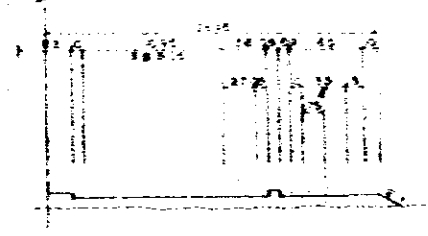

MNDR TAPER SECTION  
 SCALE 1:600

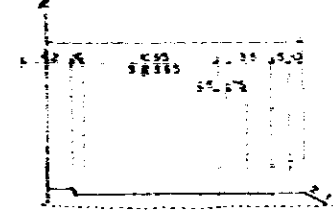

MNDR NOSE SECTION OF ACCELERATION LANE  
 SCALE 1:600

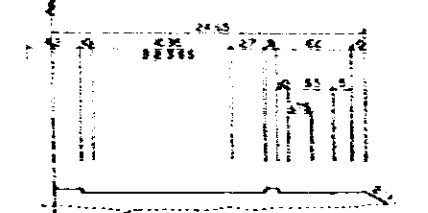

KEY MAP

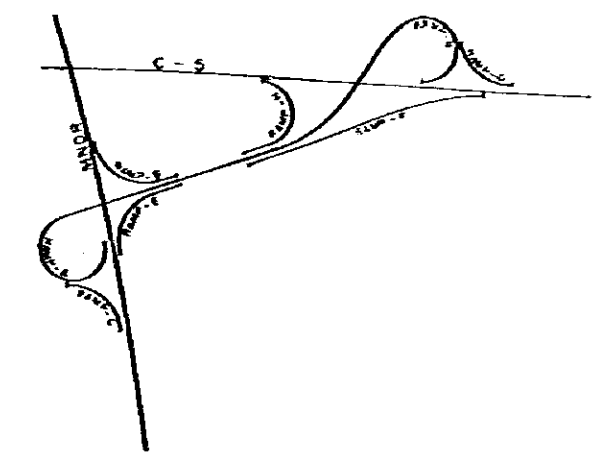

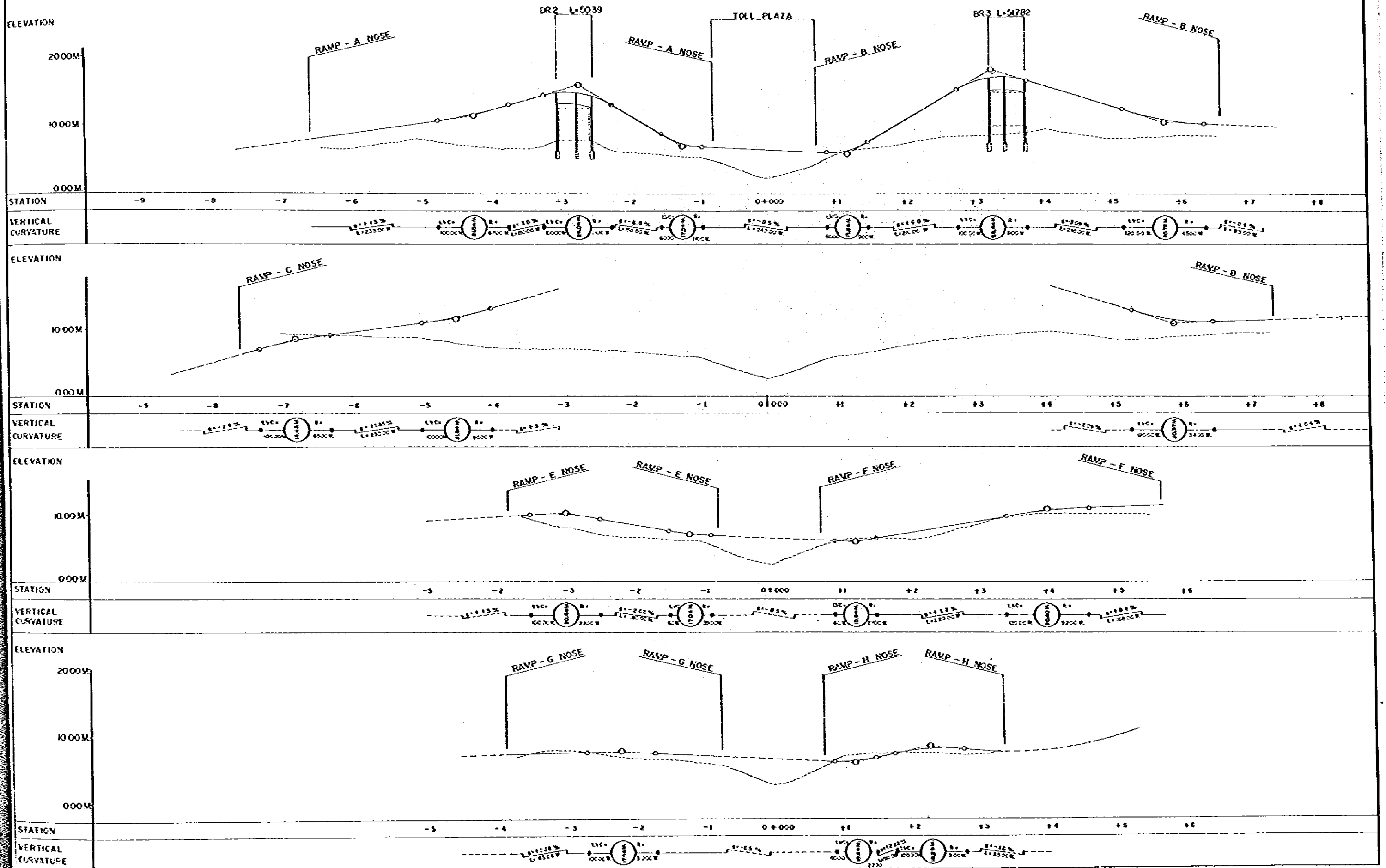

LOCATION MAP

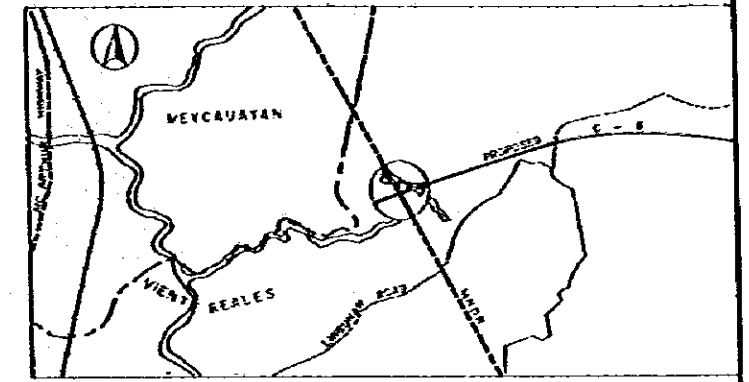

KEY MAP

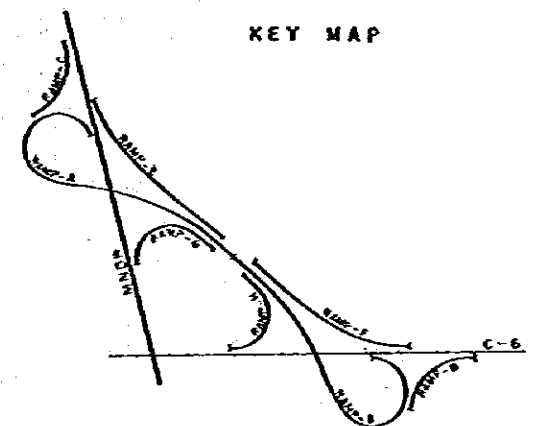

TYPICAL CROSS SECTION OF C-6  
SCALE 1:600

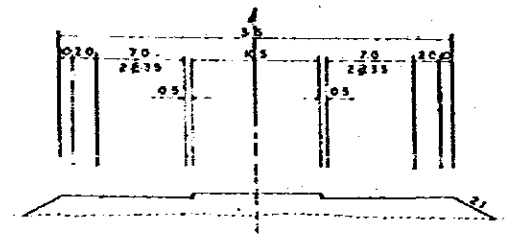

C-6 NOSE SECTION OF DECELERATION LANE  
SCALE 1:600

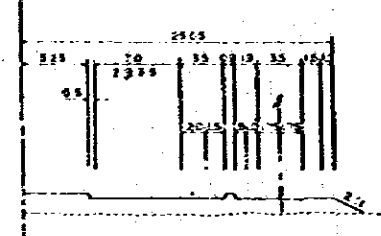

C-6 TAPER SECTION  
SCALE 1:600

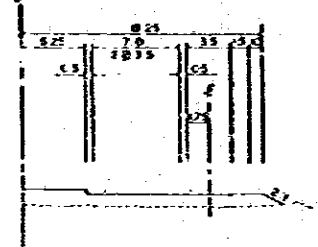

C-6 NOSE SECTION OF ACCELERATION LANE  
SCALE 1:600

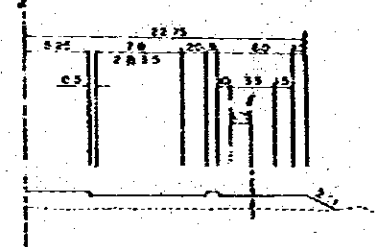

TYPICAL CROSS SECTION OF MNDR  
SCALE 1:600

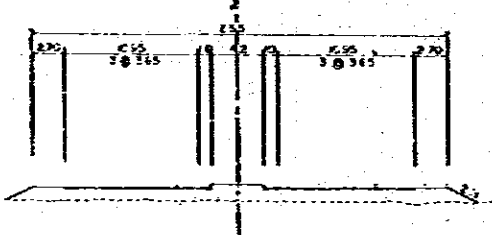

MNDR TAPER SECTION  
SCALE 1:600

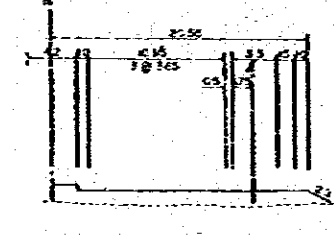

MNDR NOSE SECTION OF DECELERATION LANE  
SCALE 1:600

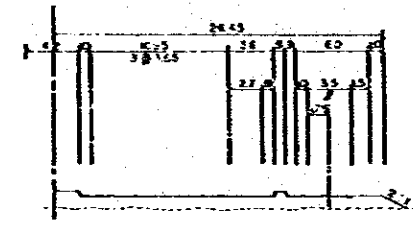

MNDR NOSE SECTION OF ACCELERATION LANE  
SCALE 1:600

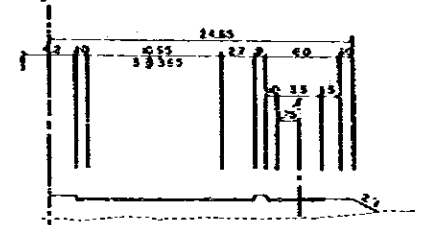

RAMWAY SECTION  
SCALE 1:600  
TWO WAY - ONE LANE

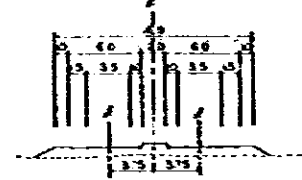

RAMWAY SECTION  
SCALE 1:600  
ONE WAY - ONE LANE

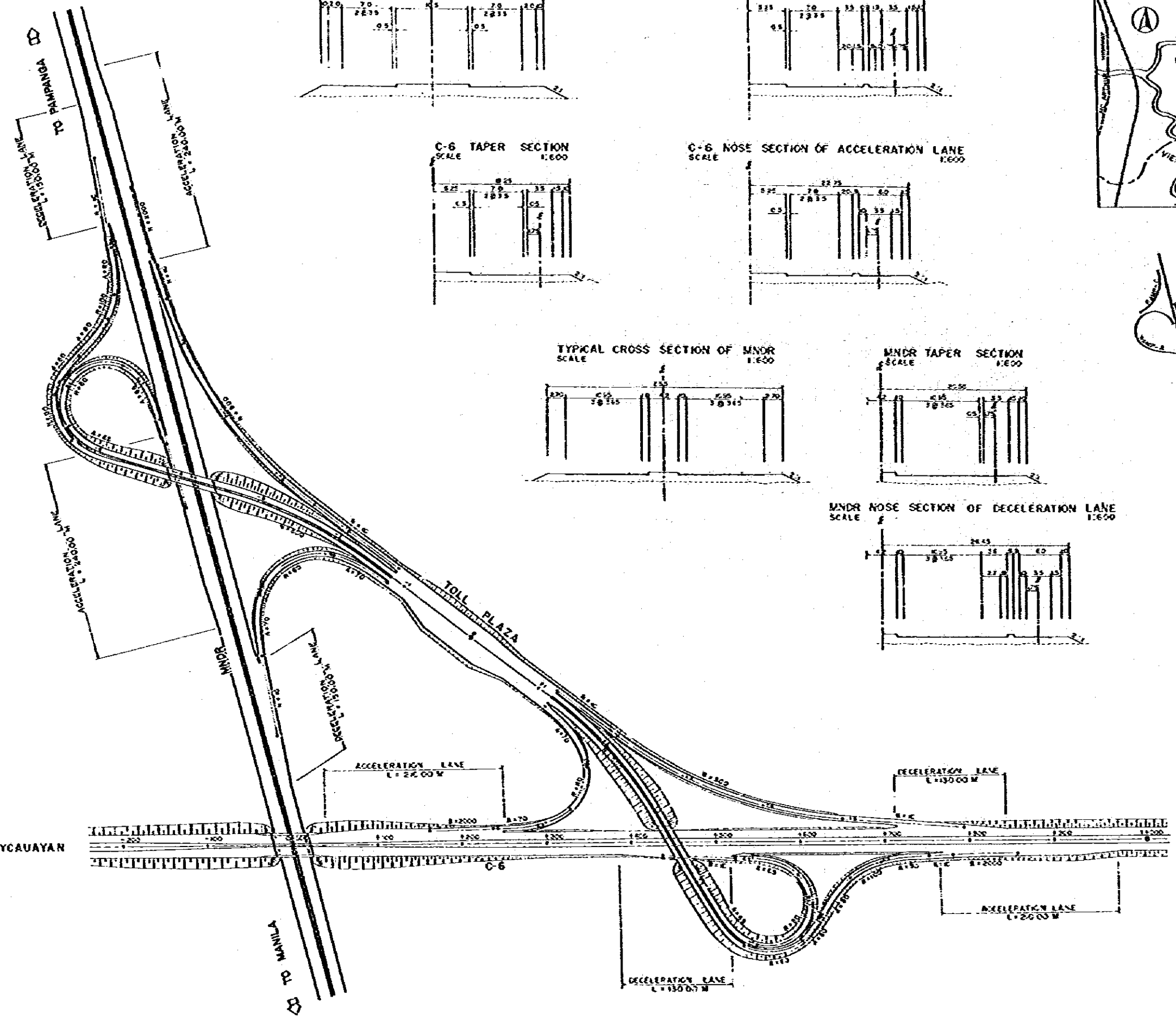
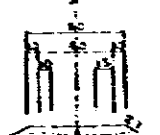

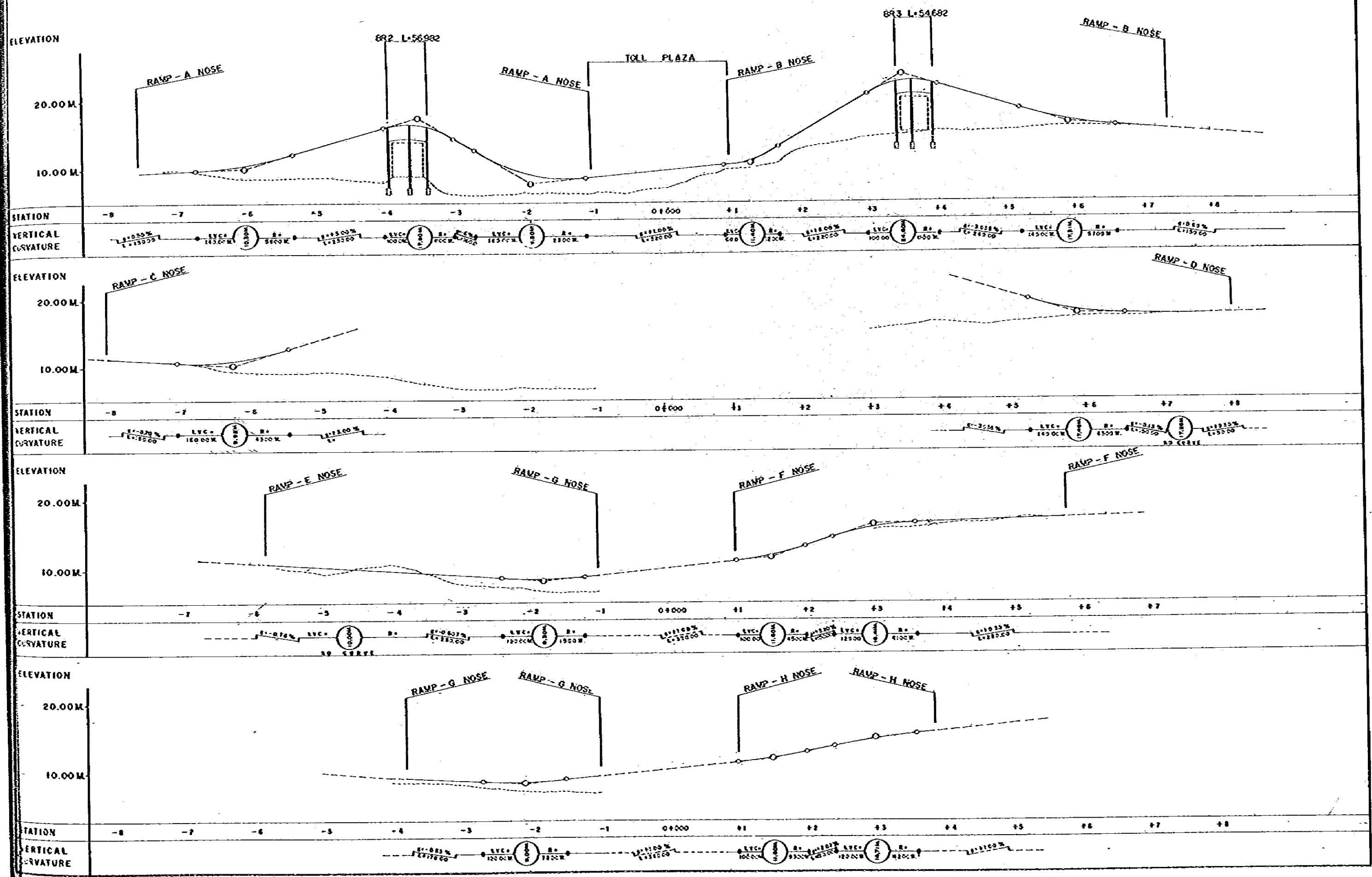

TYPICAL CROSS SECTION (C-5)  
SCALE 1:600 MTS.

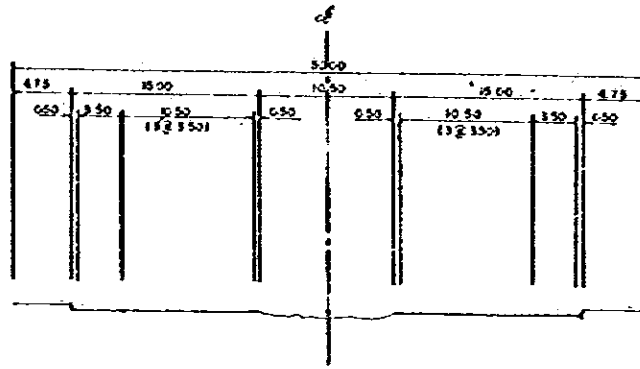

LOCATION MAP  
SCALE 1:50000 M.

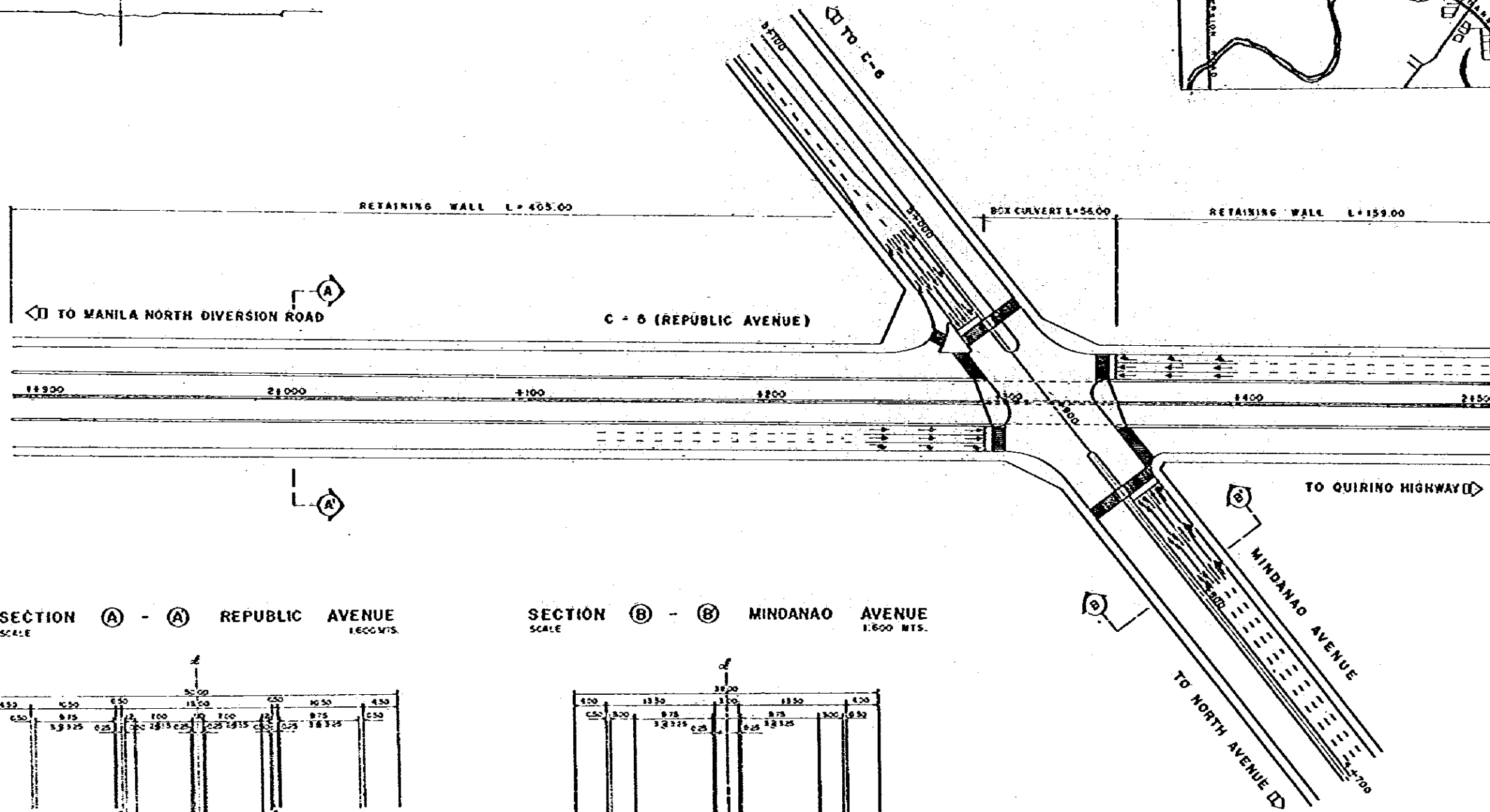
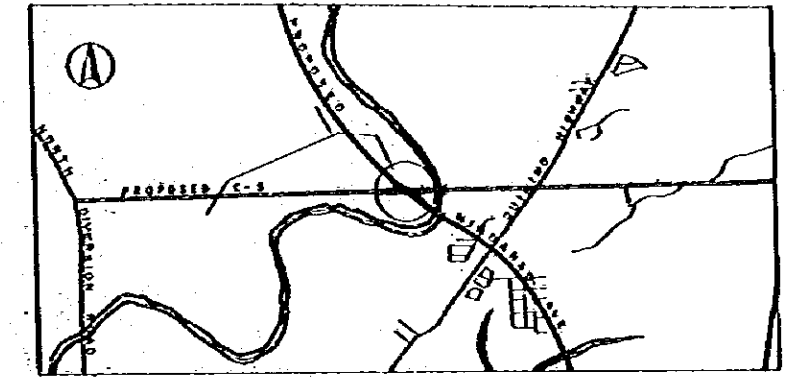

SECTION (A) - (A) REPUBLIC AVENUE  
SCALE 1:600 MTS.

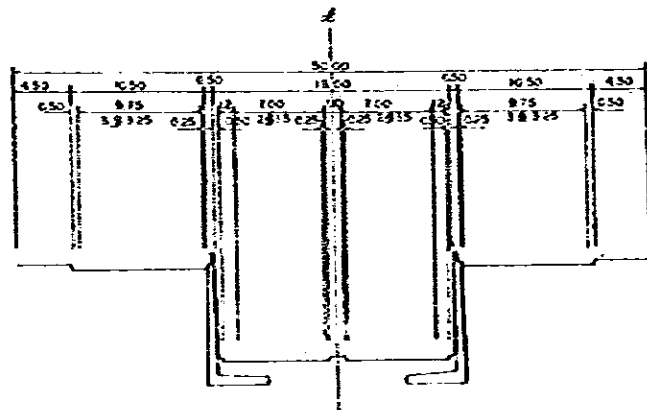

SECTION (B) - (B) MINDANAO AVENUE  
SCALE 1:600 MTS.

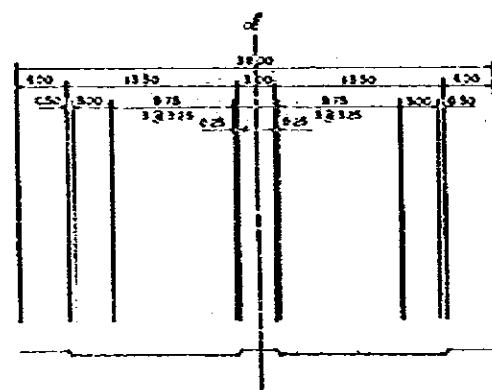

**TYPICAL CROSS SECTION C-5 (REPUBLIC AVENUE)**  
 SCALE 1:600 MTS

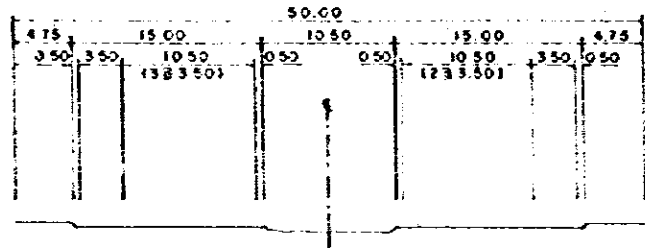

**SECTION (A) - (A) C-5 (REPUBLIC AVENUE)**  
 SCALE 1:600 MTS

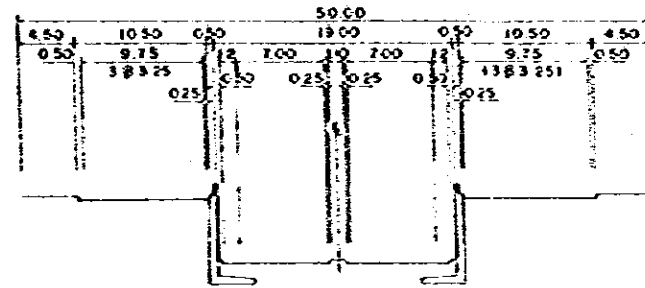

**SECTION (B) - (B) QUIRINO HIGHWAY**  
 SCALE 1:600 MTS

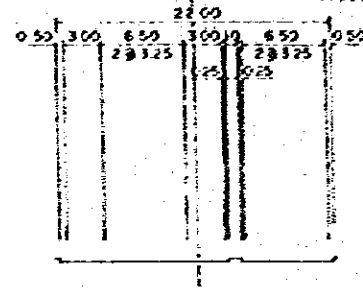

**SECTION (C) - (C) QUIRINO HIGHWAY**  
 SCALE 1:600 MTS

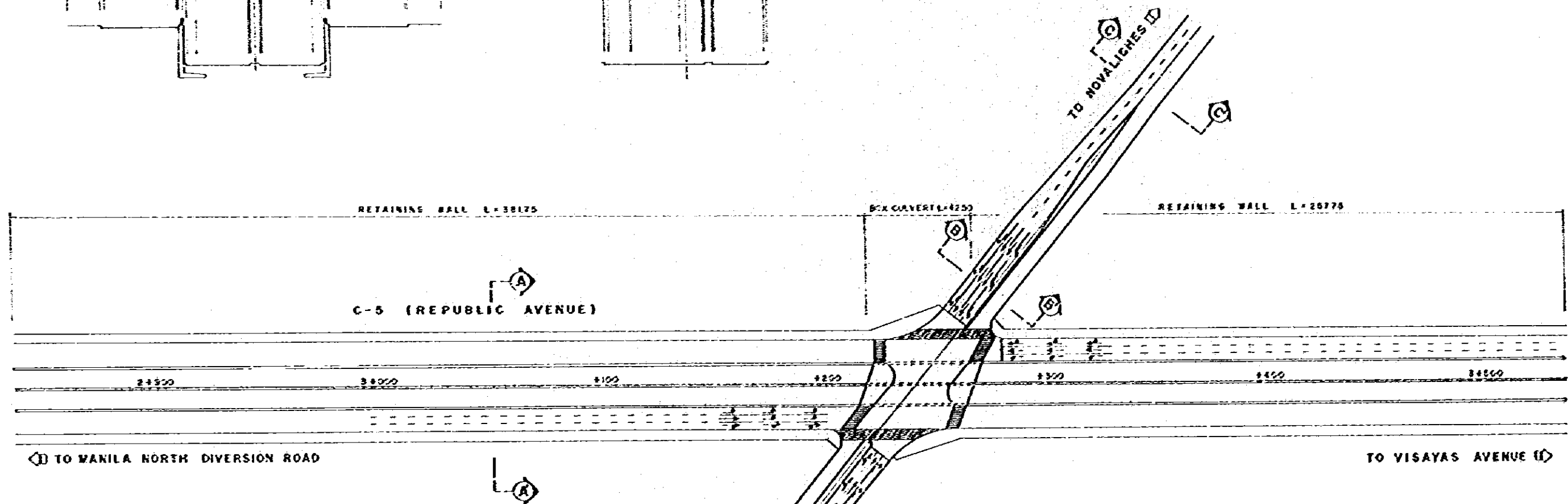
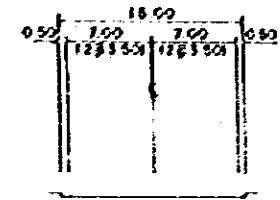

**LOCATION MAP**  
 SCALE 1:20000 MTS

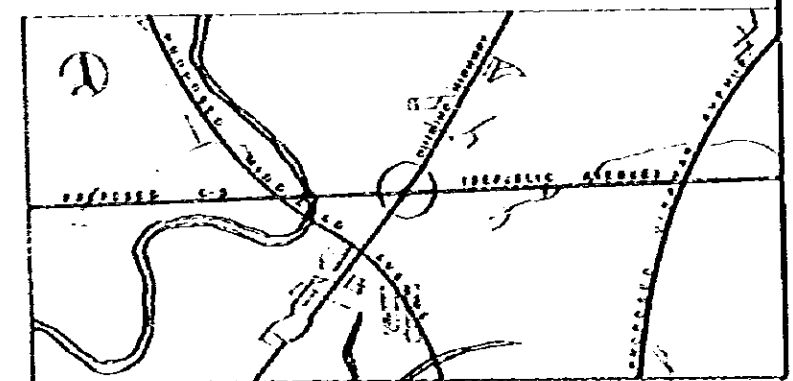

TYPICAL CROSS SECTION C-5 (REPUBLIC AVENUE)  
 SCALE 1:600 MTS

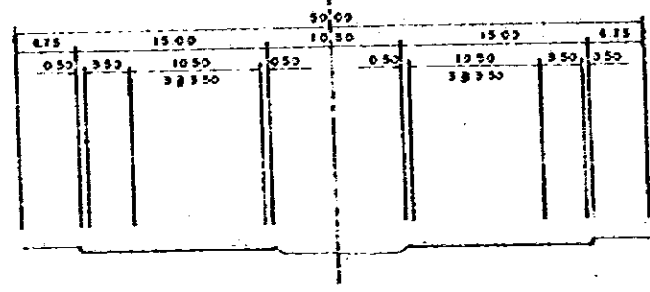

SECTION (B) - (B) C-5 (VISAYAS AVENUE)  
 SCALE 1:600 MTS

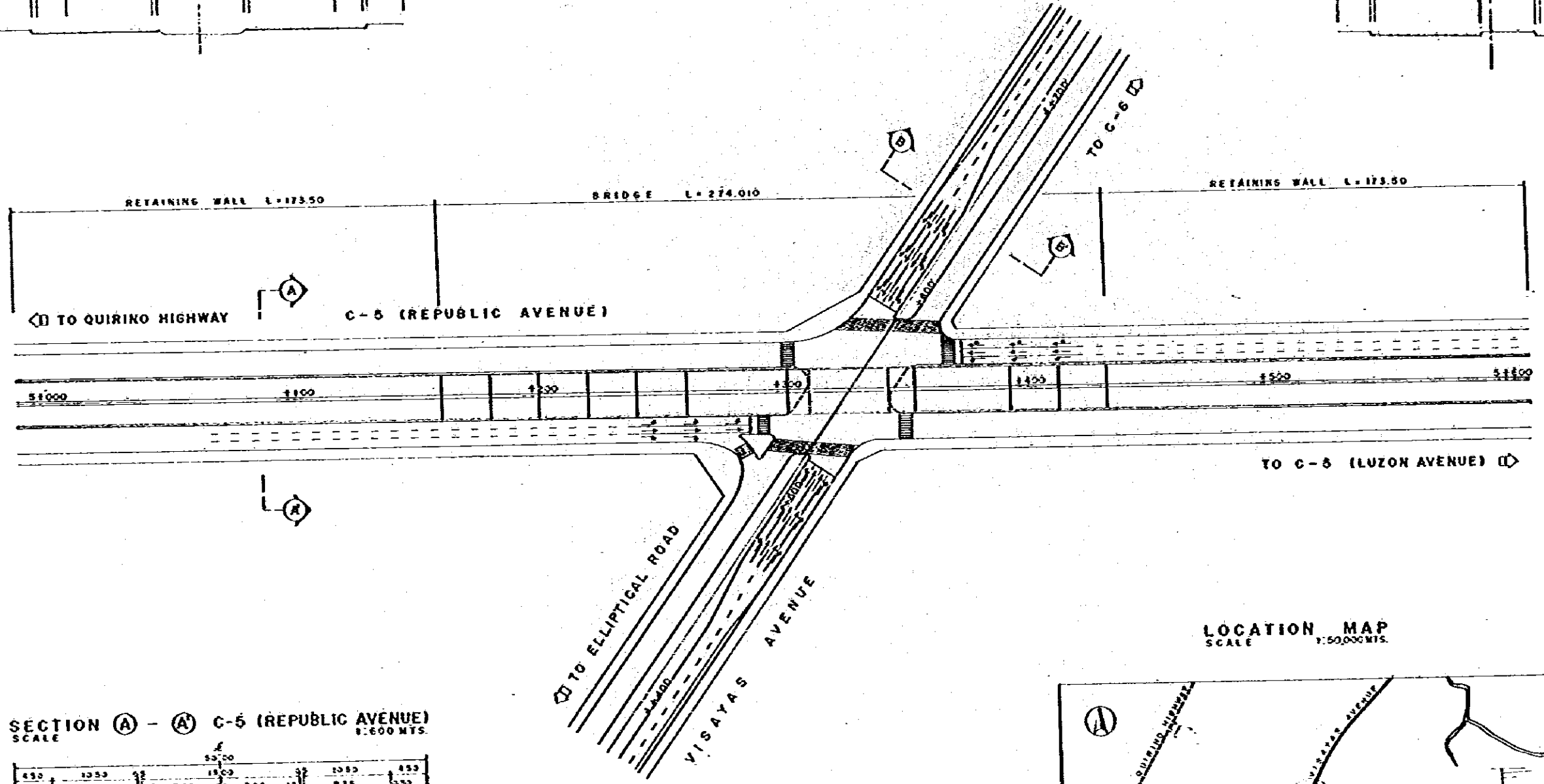
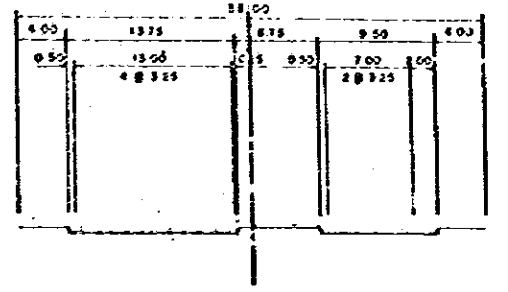

SECTION (A) - (A) C-5 (REPUBLIC AVENUE)  
 SCALE 1:600 MTS

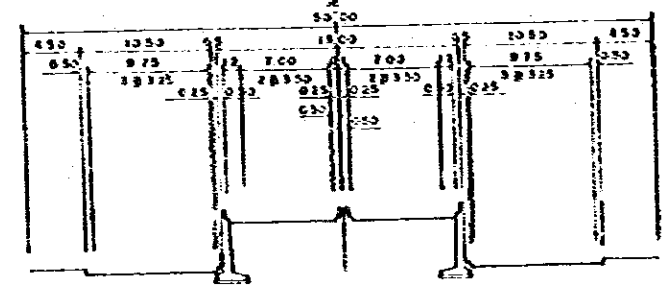

LOCATION MAP  
 SCALE 1:50,000 MTS

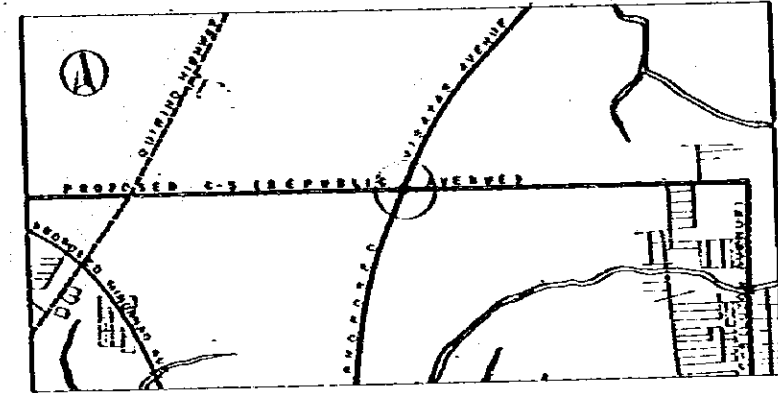





**SECTION (A) - (A) DON MARIANO MARCOS HIGHWAY**  
SCALE 1:600 MTS.

THE METRO MANILA OUTER MAJOR ROADS PROJECT (NORTHERN PACKAGE)  
SCALE: HOR: 1:20000 VERT: 1:4000  
**C-5 / DON MARIANO MARCOS HIGHWAY** 40/66

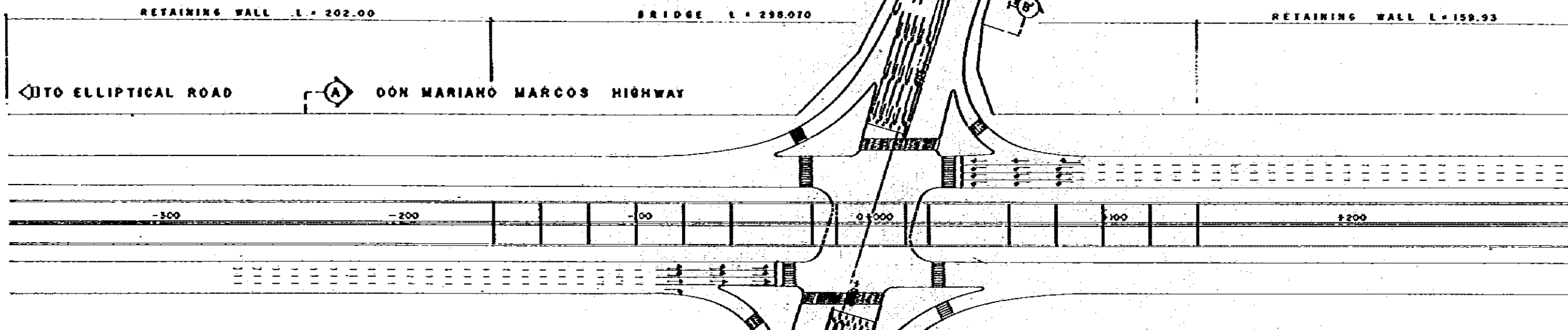
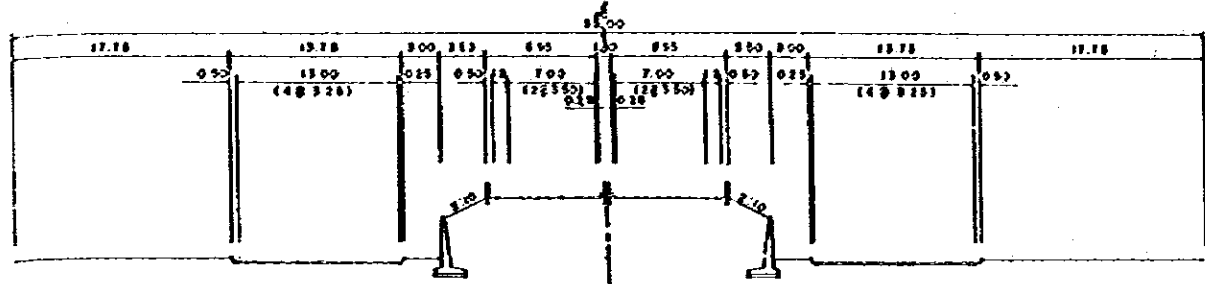

**SECTION (B) - (B) C-5 (LUZON AVENUE)**  
SCALE 1:600 MTS.

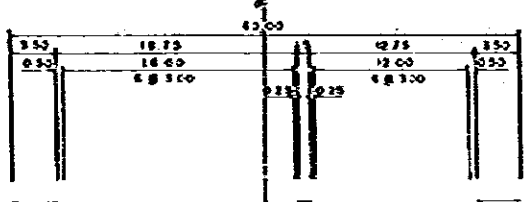

**SECTION (C) - (C) C-5 (KATIPUNAN AVENUE)**  
SCALE 1:600 MTS.

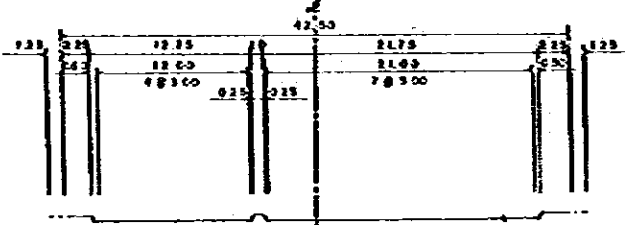

**LOCATION MAP**  
SCALE 1:50,000 MTS.

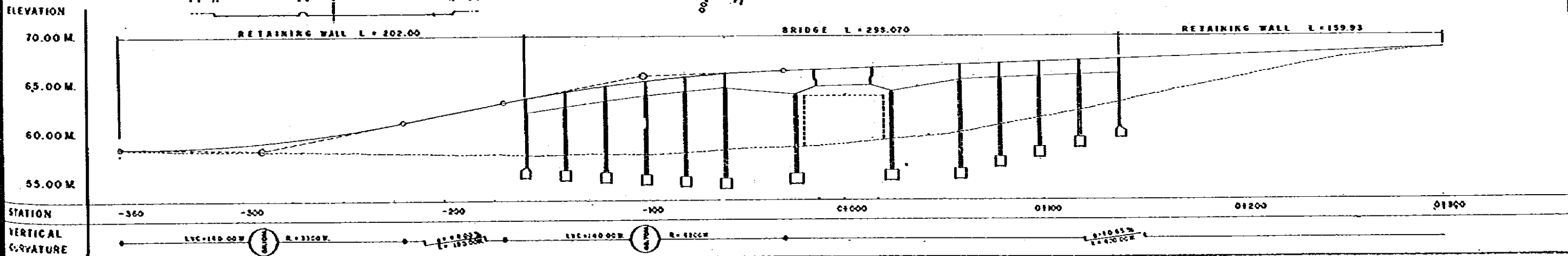
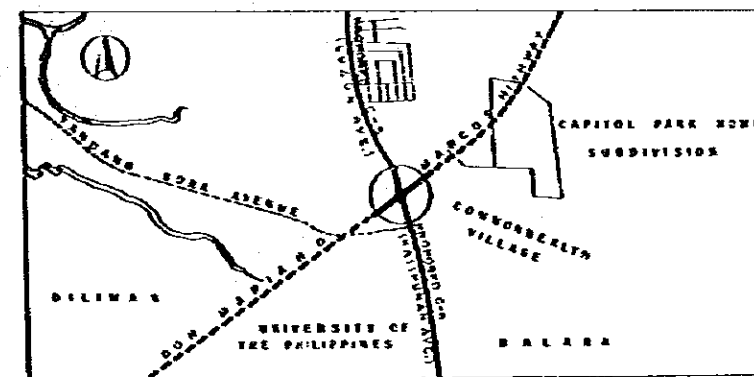

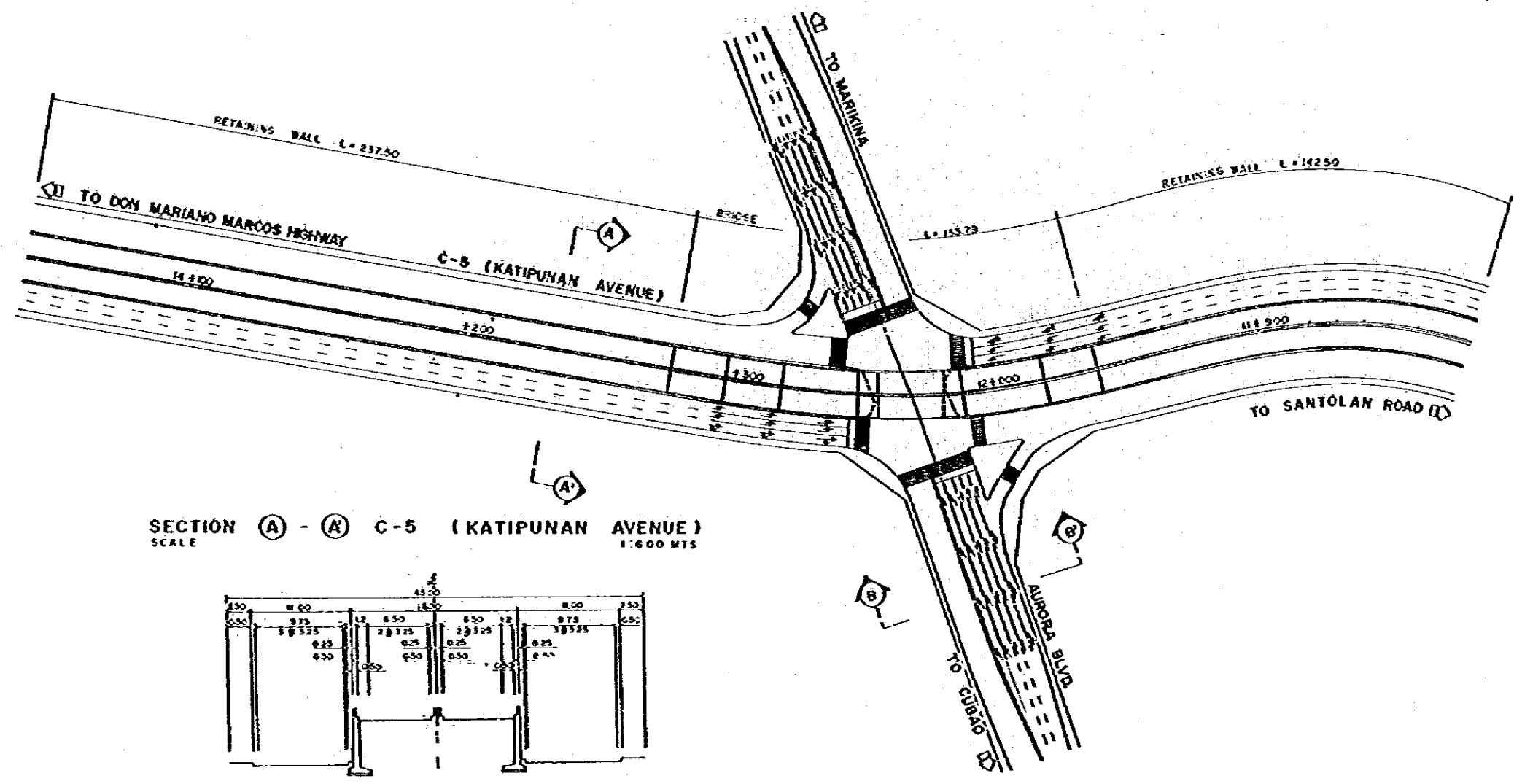

SECTION (A) - (A) C-5 (KATIPUNAN AVENUE)  
 SCALE 1:600 MTS

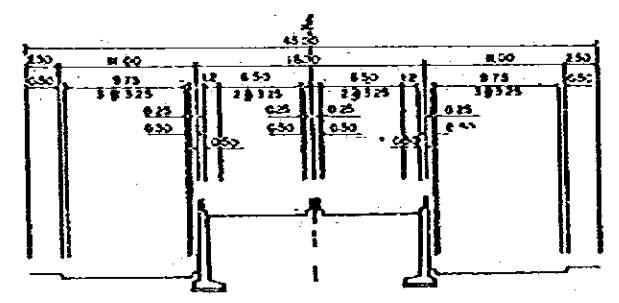

SECTION B - B AURORA BOULEVARD  
 SCALE 1:600 MTS

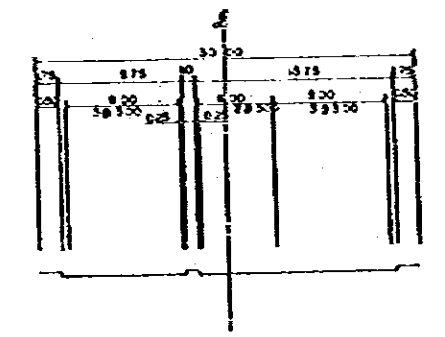

LOCATION MAP  
 SCALE 1:50000 M

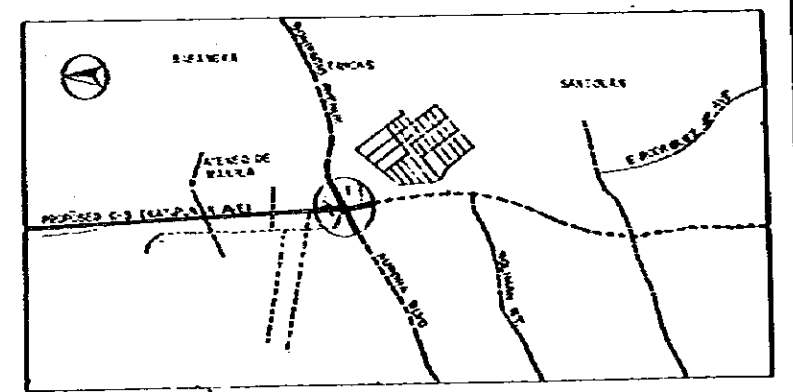

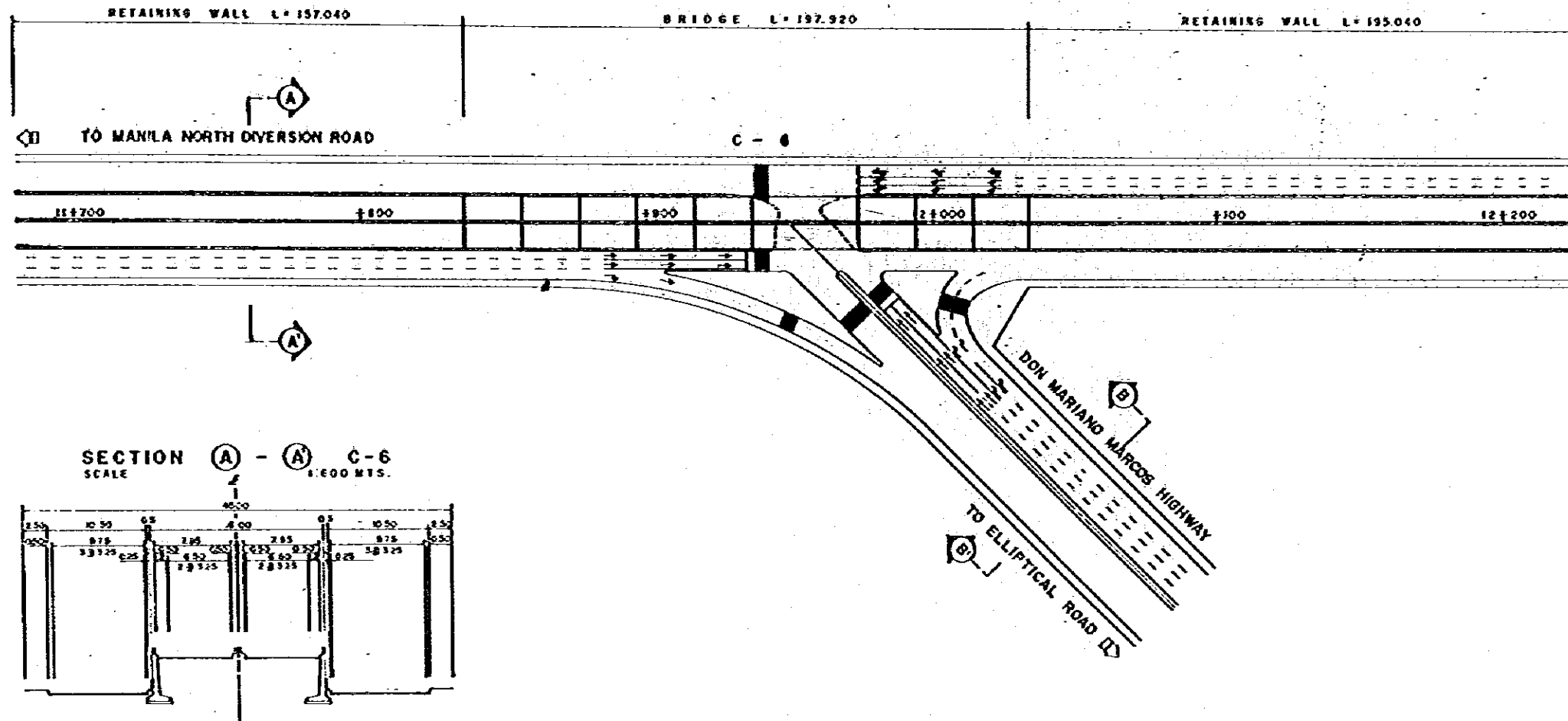

SECTION (A) - (A) C-6  
 SCALE 1:600 MTS.

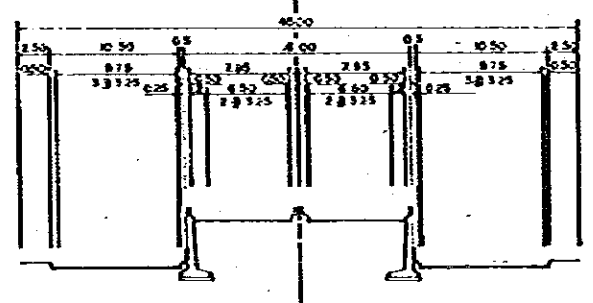

SECTION (B) - (B) DON MARIANO MARCOS HIGHWAY  
 SCALE 1:600 MTS.

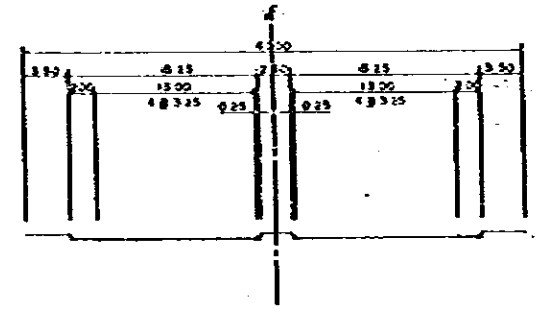

LOCATION MAP  
 SCALE 1:50,000

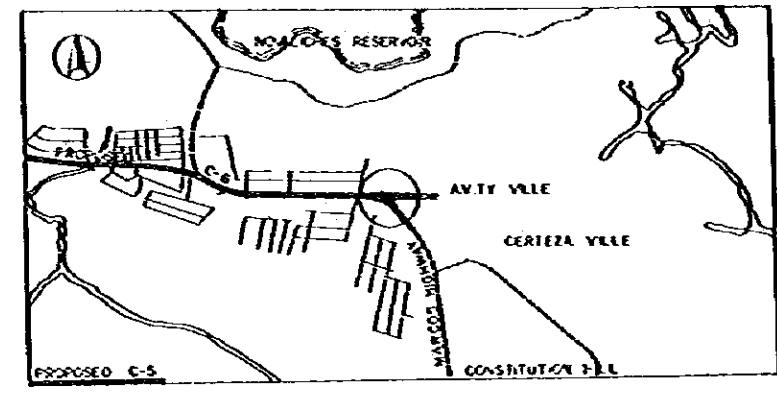

# C-5 BR-1

THE METRO MANILA OUTER MAJOR ROADS PROJECT (NORTHERN PACKAGE I)		DESIGN NO. 191
SCALE	C-5 BR-1	43/66
1:400	PLAN AND ELEVATION	
1:200		

**ELEVATION**  
SCALE 1:400

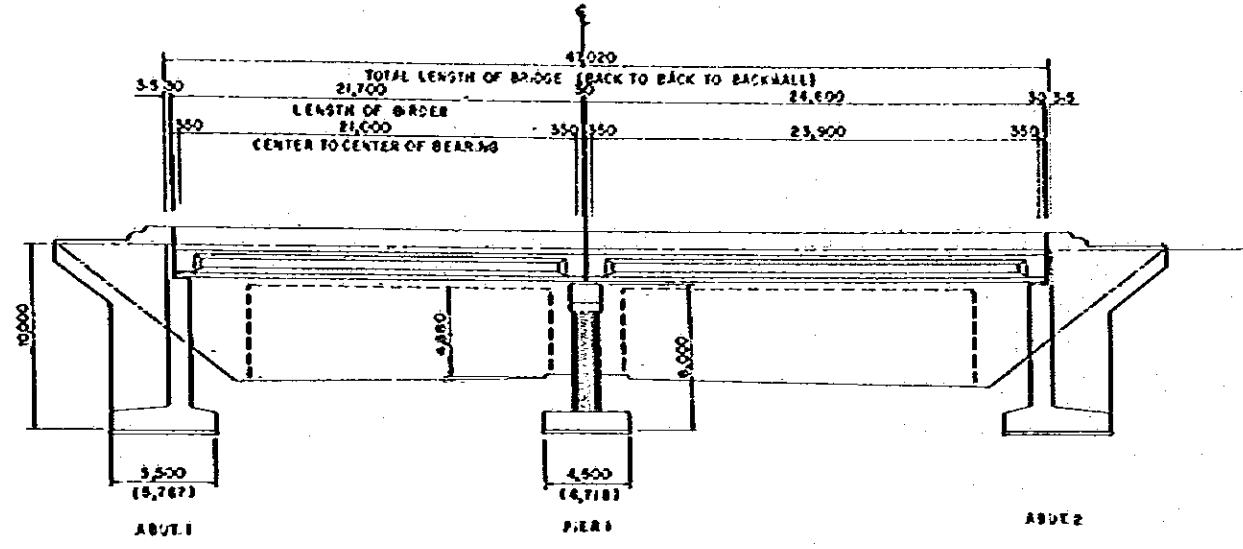

**CROSS SECTION**  
SCALE 1:200

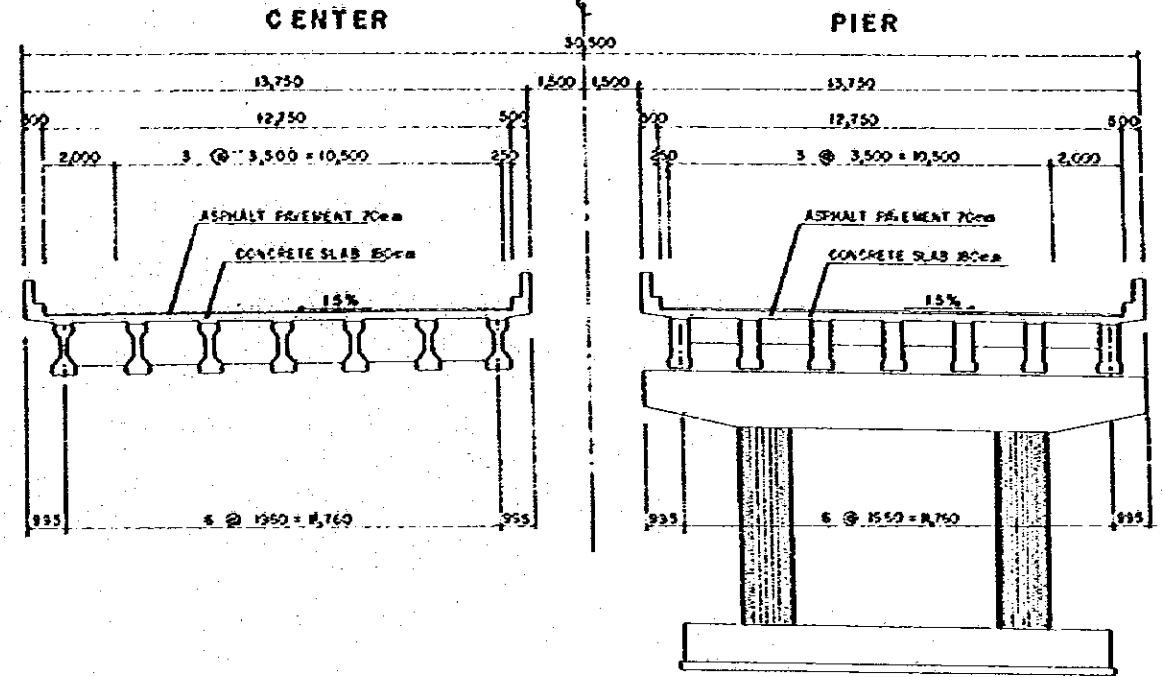

NOTE:  
E 3 INDICATES SKEW LENGTH

**PLAN**  
SCALE 1:400

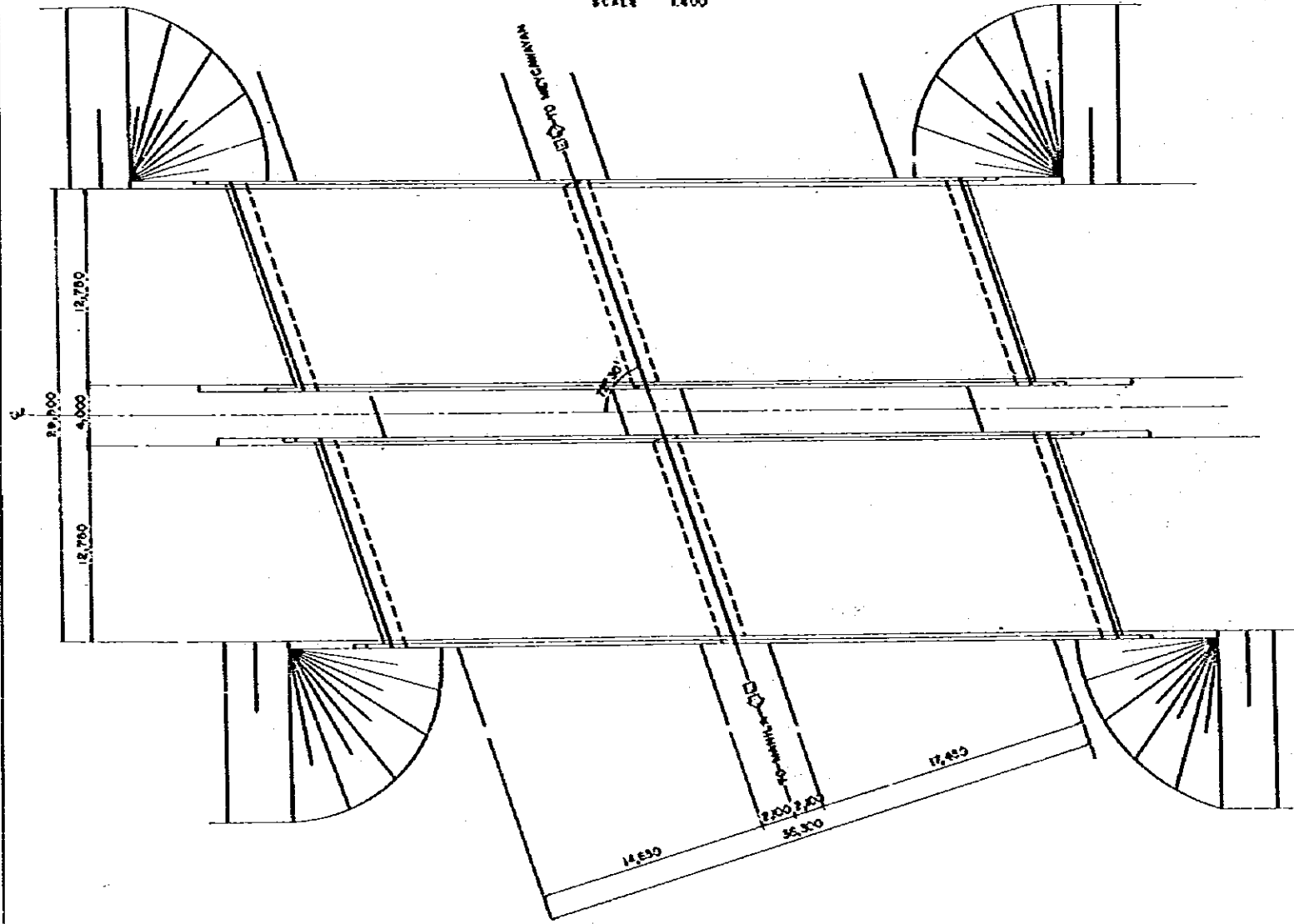

**LOCATION MAP**  
SCALE 1:50,000

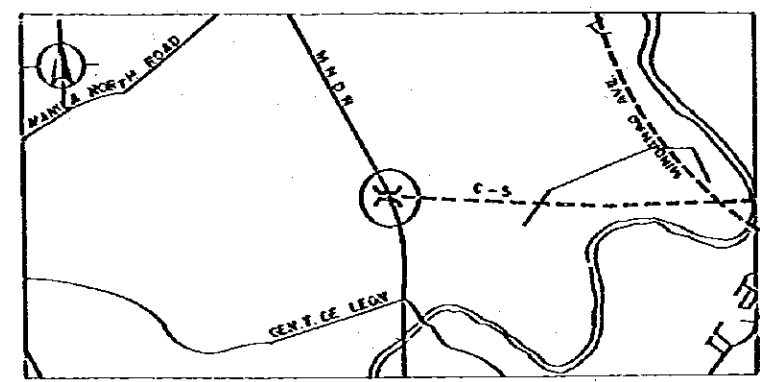

**KEY MAP**

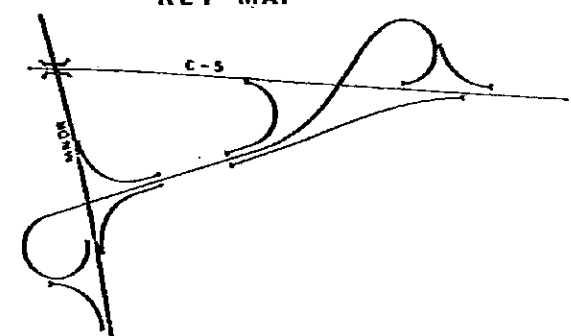

# C-5 BR-2

THE METRO MANILA OUTER MAJOR ROADS PROJECT (NORTHERN PACKAGE)		44/66
SCALE	C-5 BR-2	
1:400	PLAN AND ELEVATION	
1:200		

**ELEVATION**  
SCALE 1:400

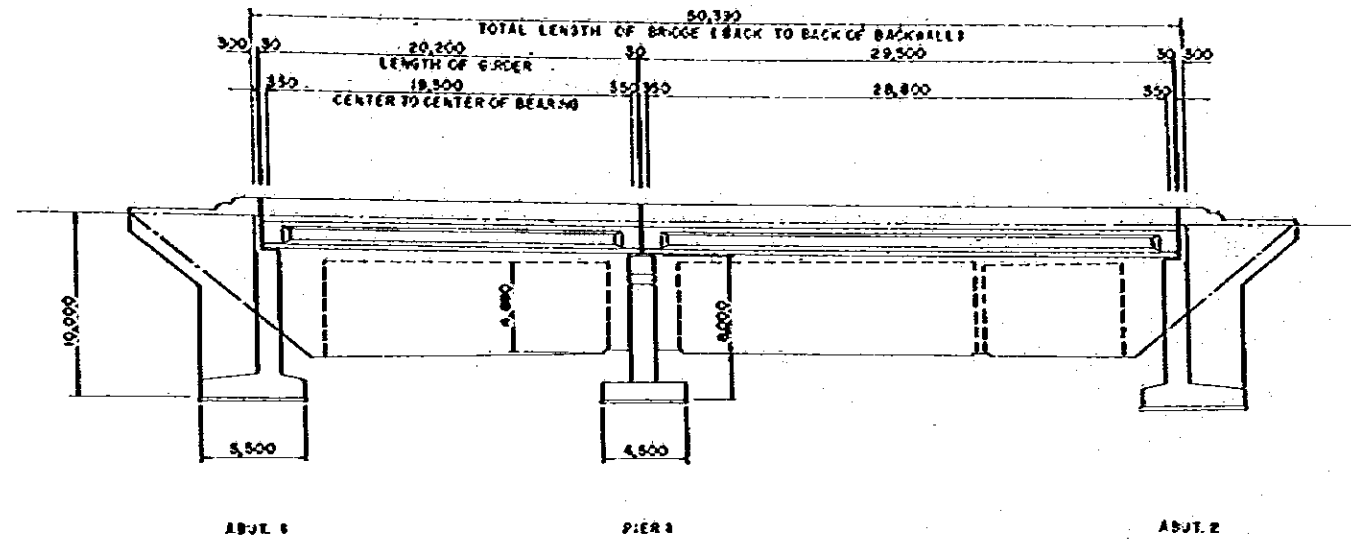

**CROSS SECTION**  
SCALE 1:200

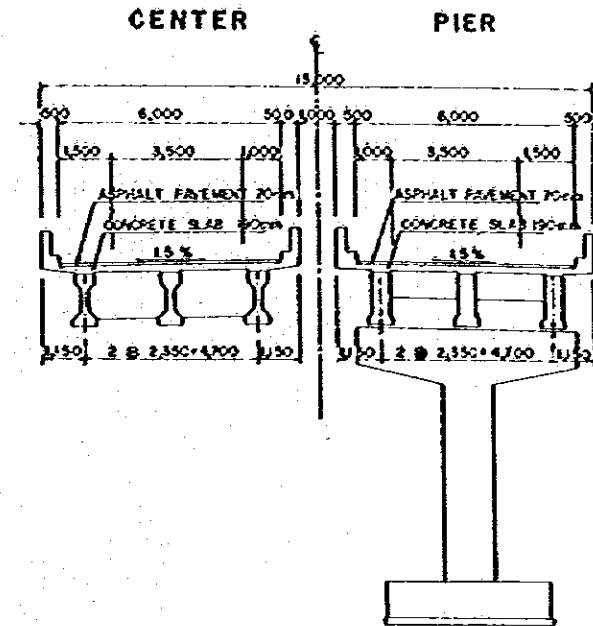

**PLAN**  
SCALE 1:400

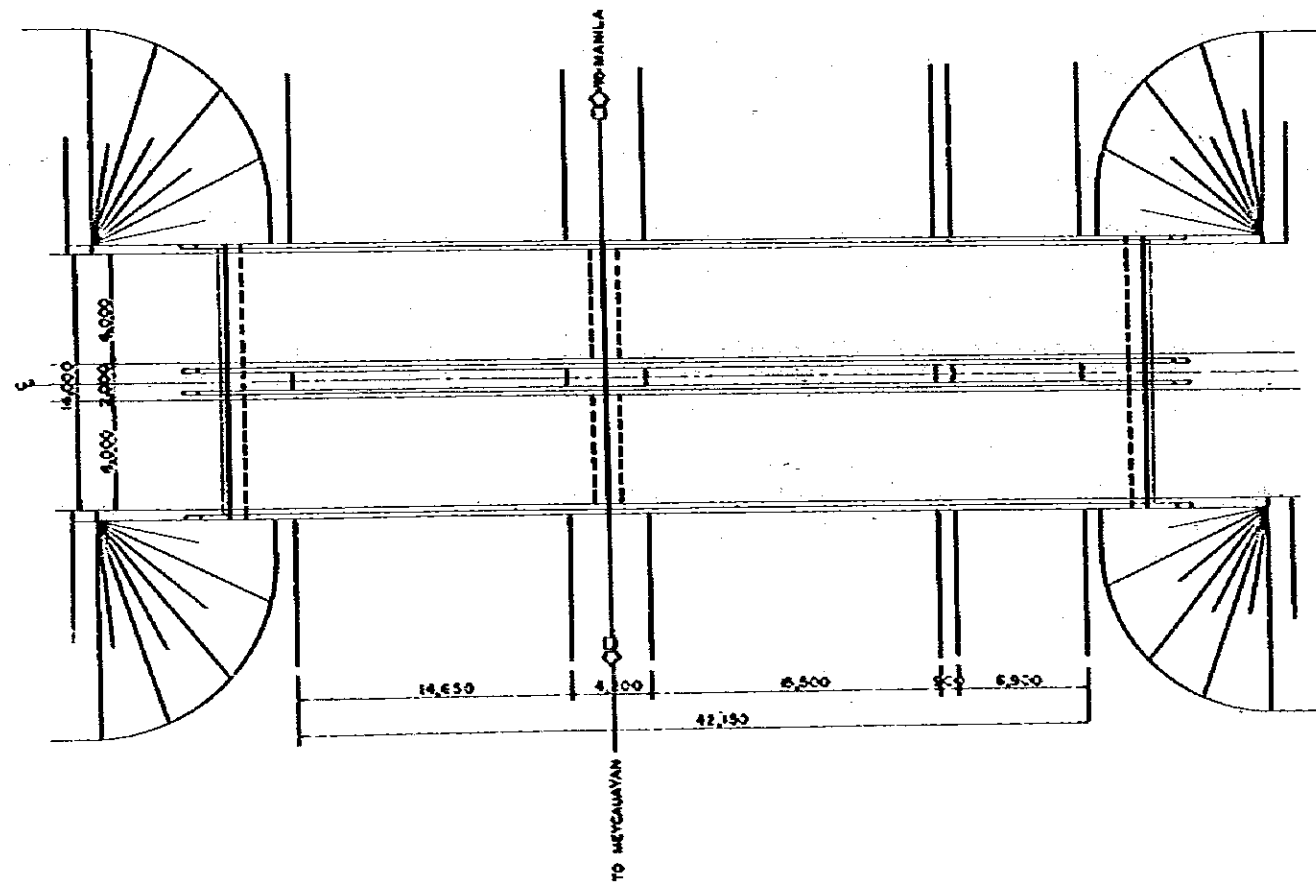

**LOCATION MAP**  
SCALE 1:60,000

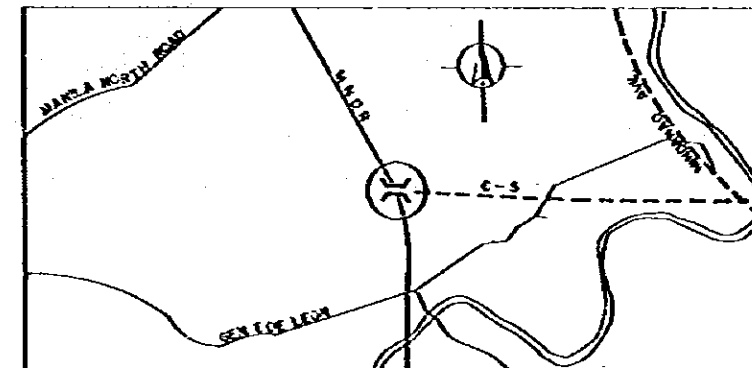

**KEY MAP**

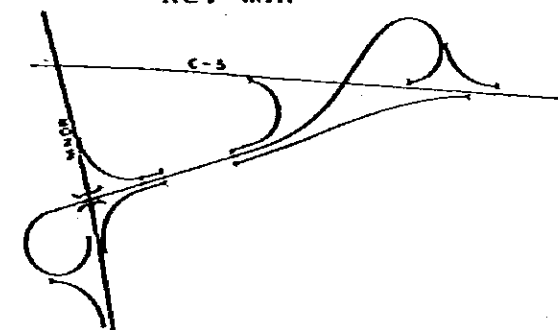

# C-5 BR-3

THE METRO MANILA OUTER MAJOR ROADS PROJECT (NORTHERN PACKAGE)		DRAWING NO.
SCALE	C-5 BR-3	45/66
1:400	PLAN AND ELEVATION	
1:200		

**ELEVATION**  
SCALE 1:400

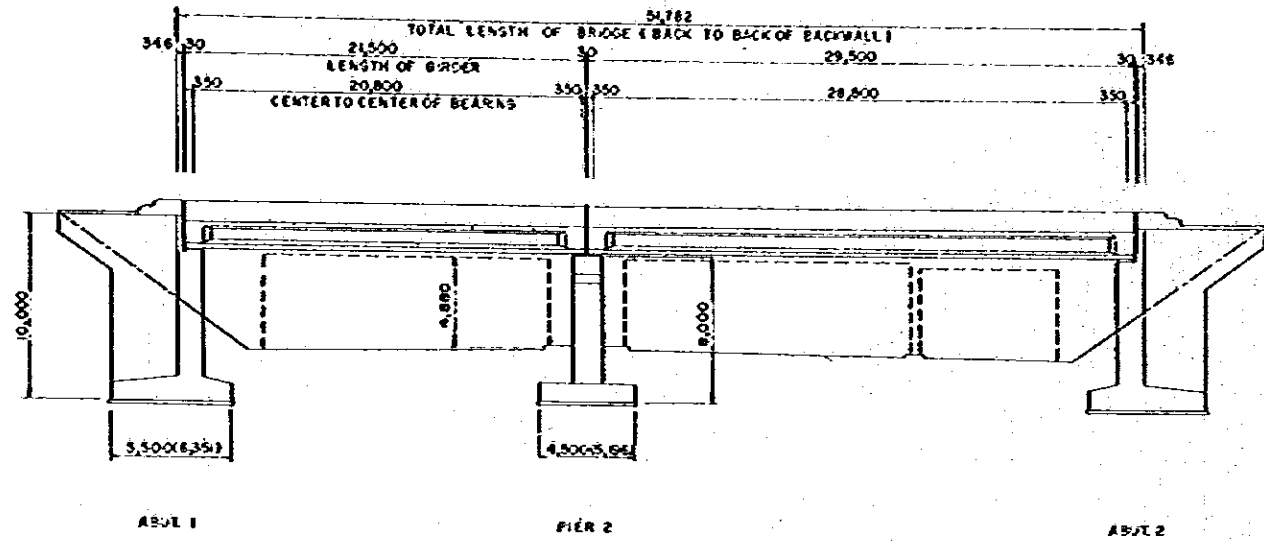

NOTE:  
E I INDICATES SKEW LENGTH

**CROSS SECTION**  
SCALE 1:200

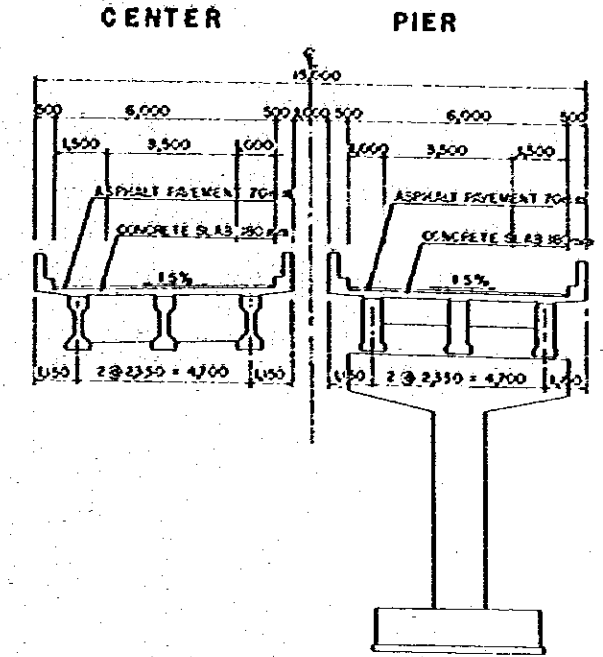

**PLAN**  
SCALE 1:400

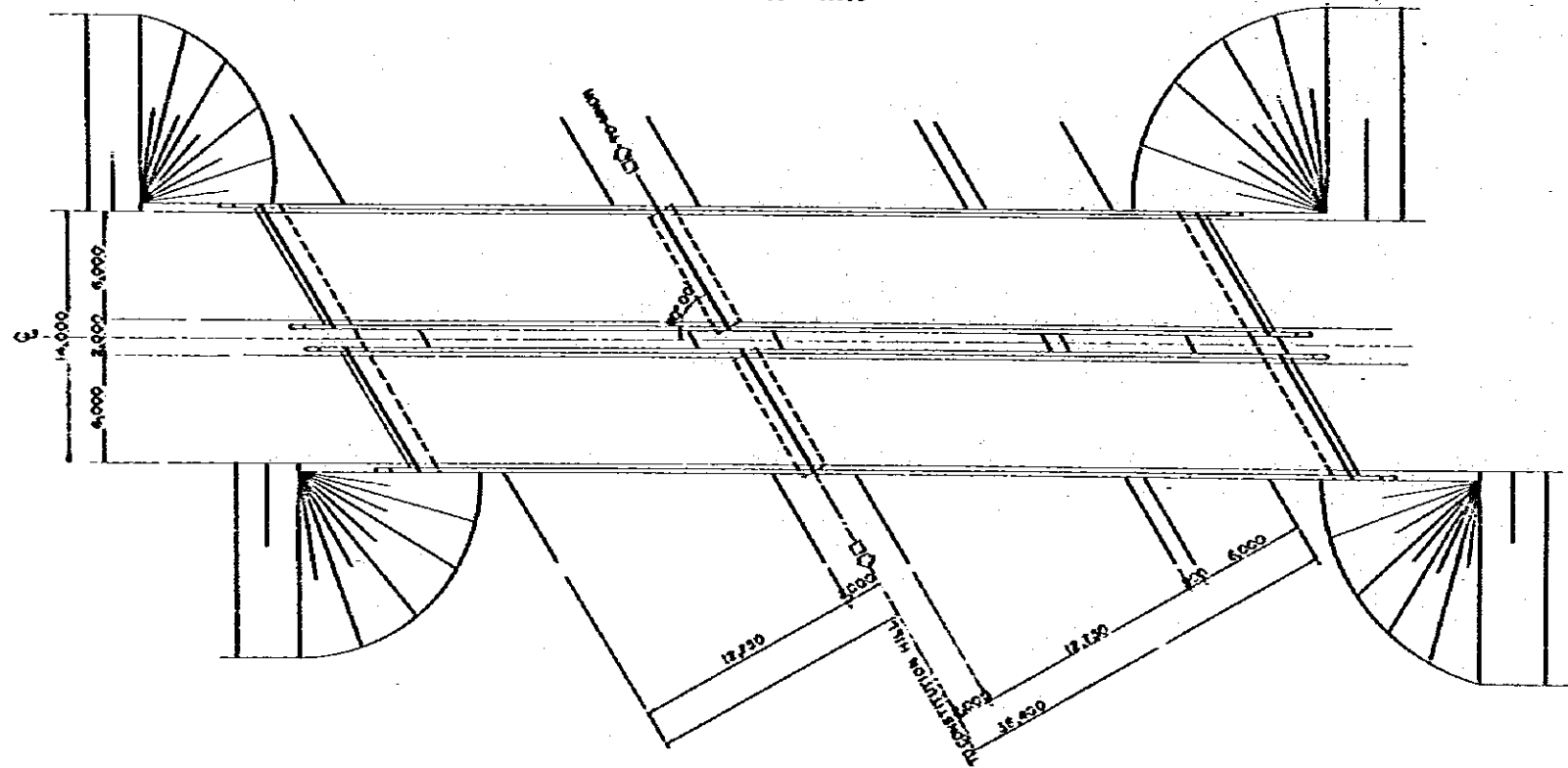

**LOCATION MAP**  
SCALE 1:50,000

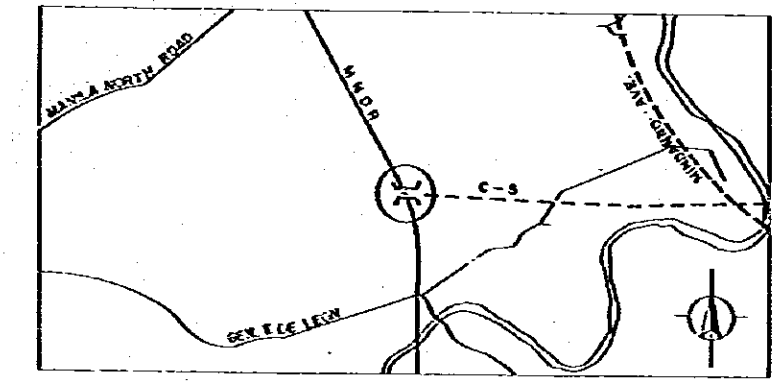

**KEY MAP**

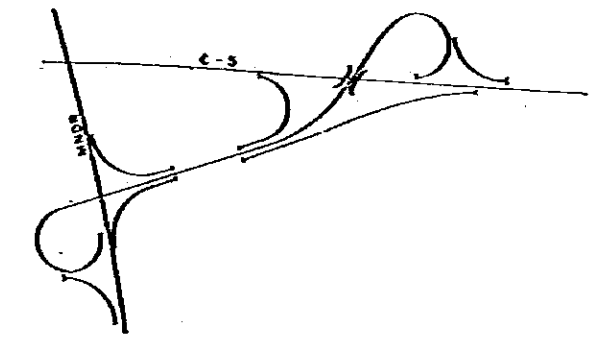

# C-5 BR-4

**ELEVATION**  
SCALE 1:400

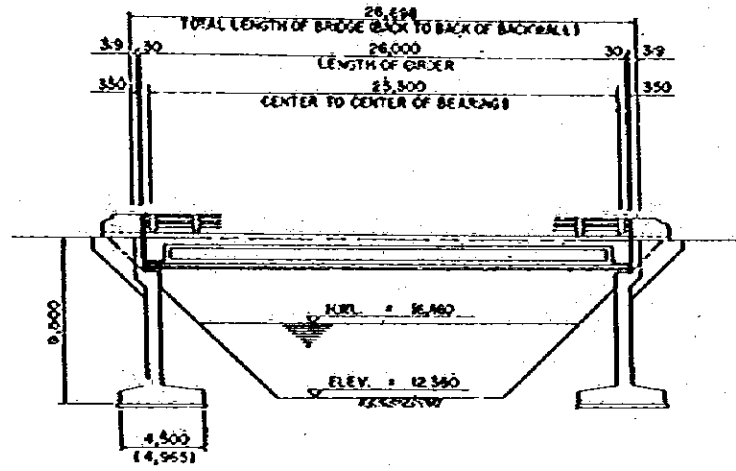

NOTE:  
 ( ) INDICATE SKEW LENGTH

**CROSS SECTION**  
SCALE 1:200

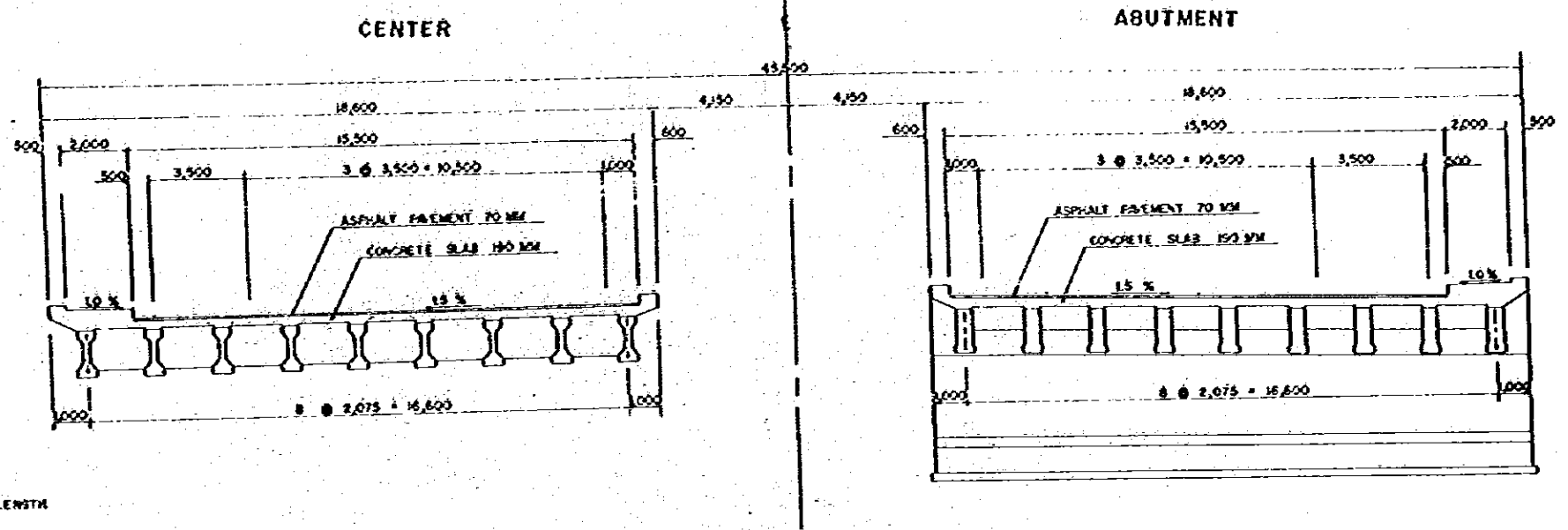

**PLAN**  
SCALE 1:400

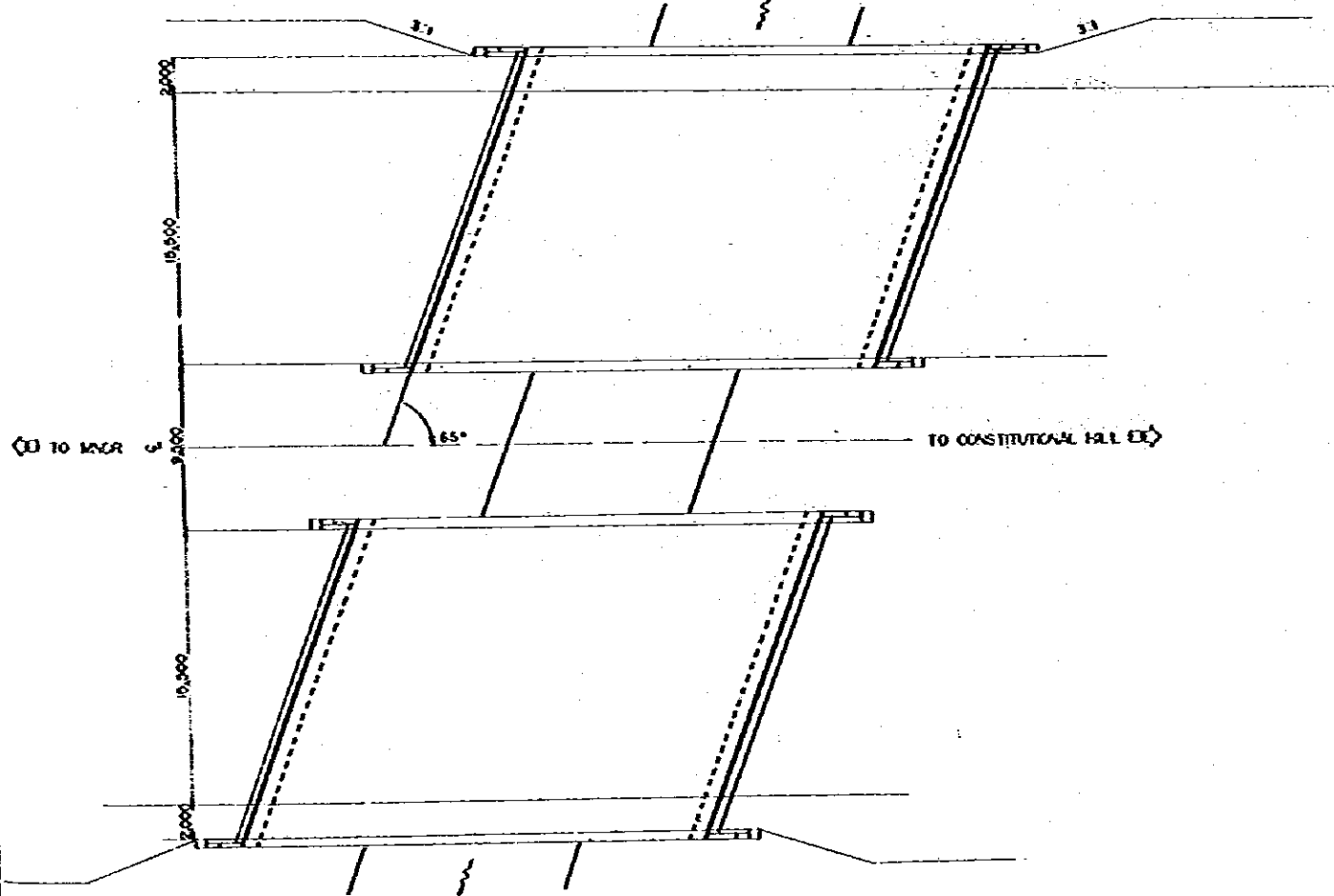

**LOCATION MAP**  
SCALE 1:50,000

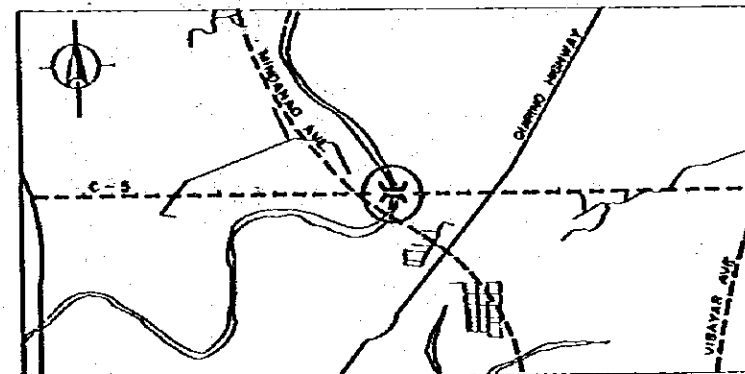

# C-5 BR-5

ELEVATION  
 SCALE 1:1000

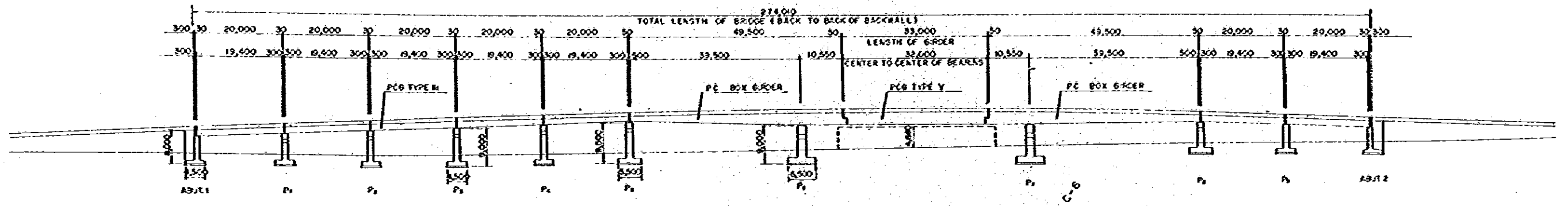

PLAN  
 SCALE 1:1000

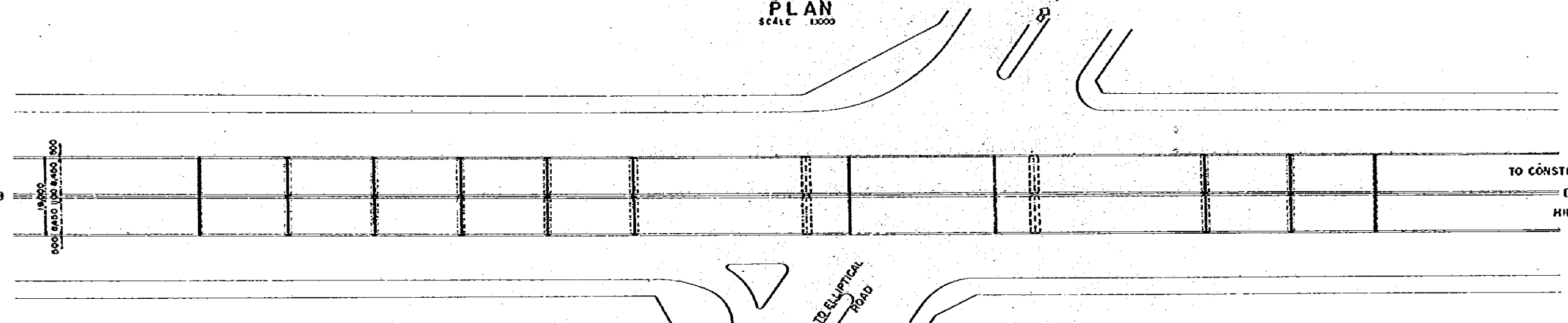

CROSS SECTION  
 SCALE 1:200

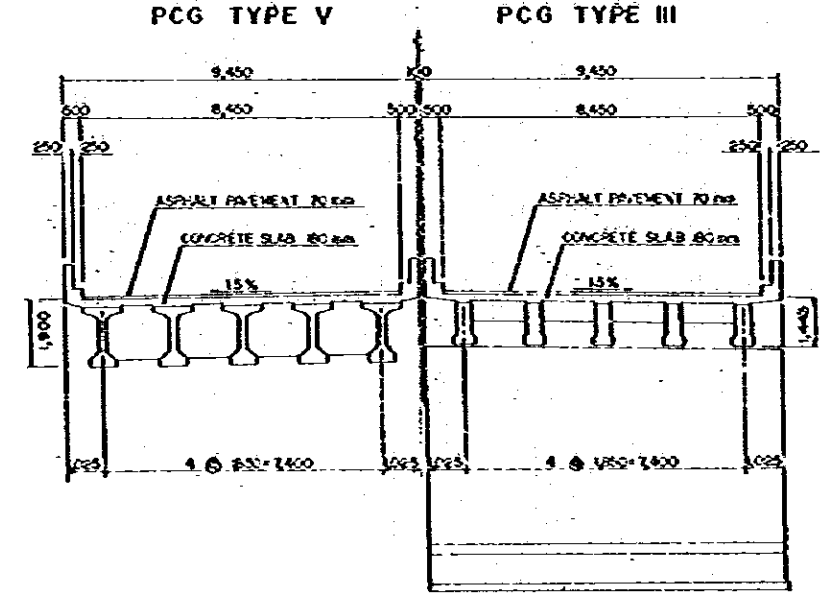
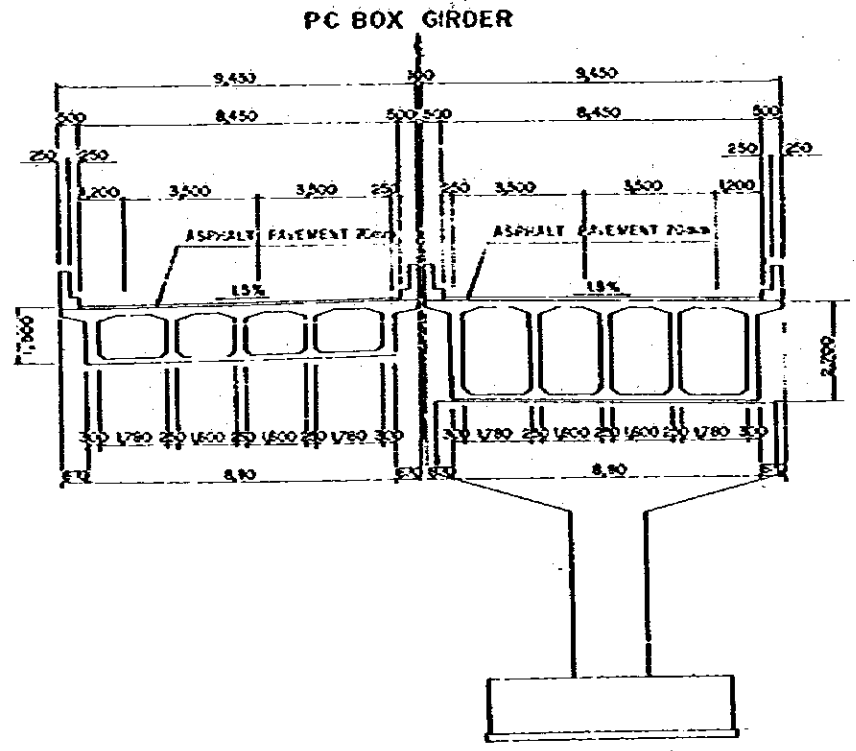

LOCATION MAP  
 SCALE 1:50,000

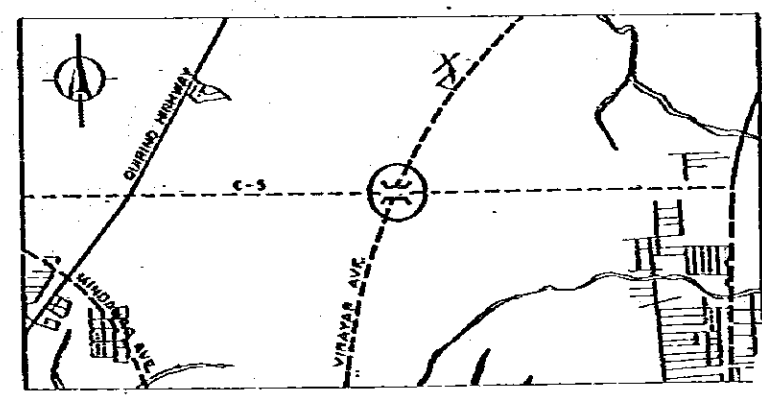



# C-5 BR-6

ELEVATION  
SCALE 1:3200

THE METRO MANILA OUTER MAJOR ROADS PROJECT (NORTHERN PACKAGE)  
 SCALE 1:200  
 1:500  
 1:200  
**C-5 BR-6**  
**PLAN AND ELEVATION**  
 48/68

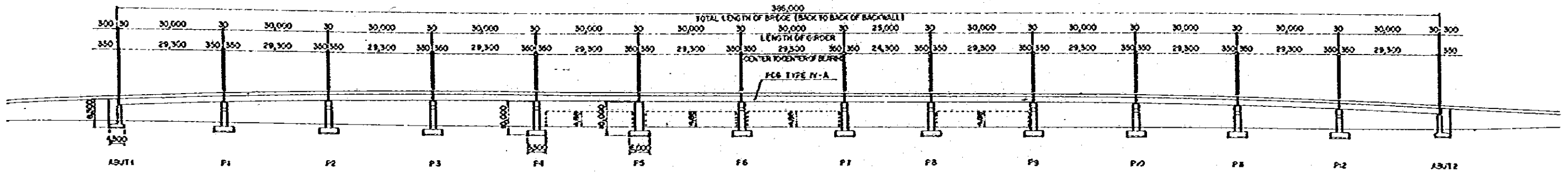

CROSS SECTION  
SCALE 1:300

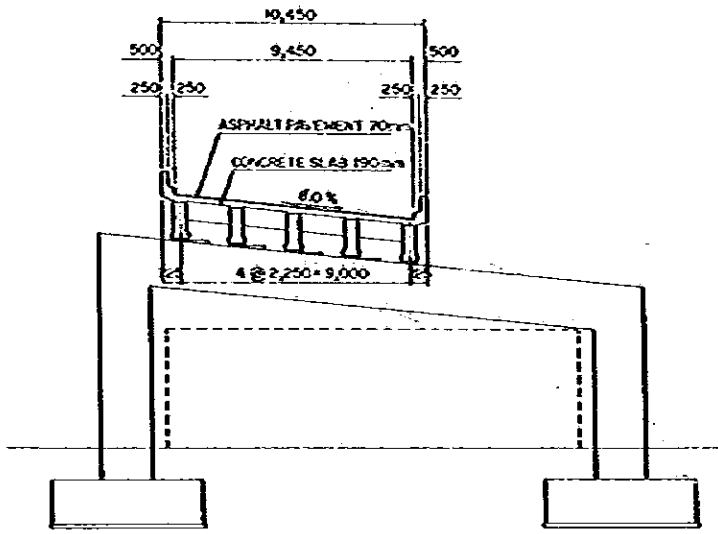

PLAN  
SCALE 1:2000

DD TO CONSTITUTION HILL

CROSS SECTION  
SCALE 1:200

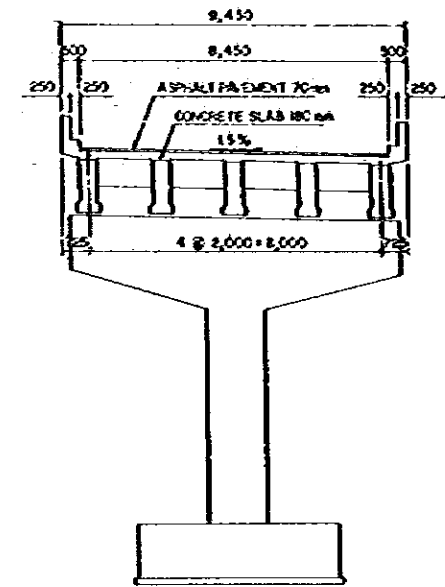

LOCATION MAP  
SCALE 1:50,000

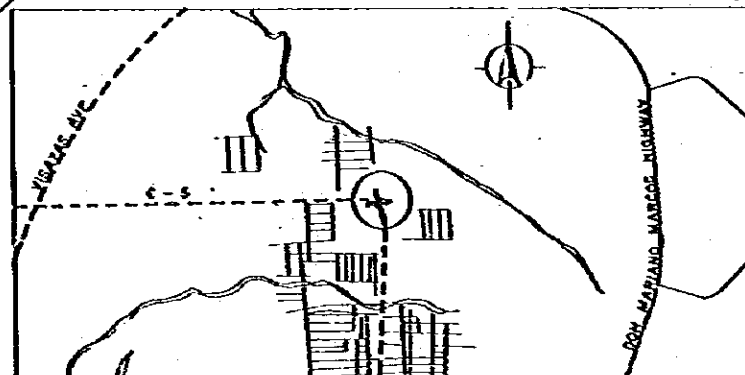

DD TO MNDP

DD TO DON MARIANO MARCOS HIGHWAY

# C-5 BR-7

THE METRO MANILA OUTER MAJOR ROADS PROJECT (NORTHERN PACKAGE)  
 SCALE 1:400  
 C-5 BR-7  
 PLAN AND ELEVATION  
 49/66

**ELEVATION**  
SCALE 1:400

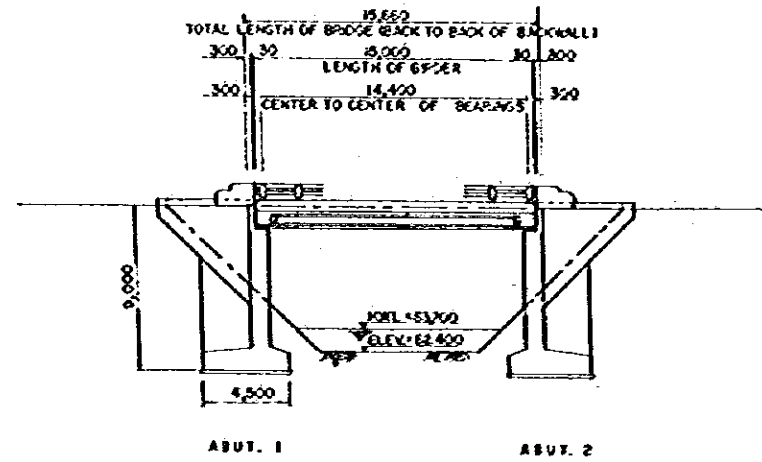

**PLAN**  
SCALE 1:400

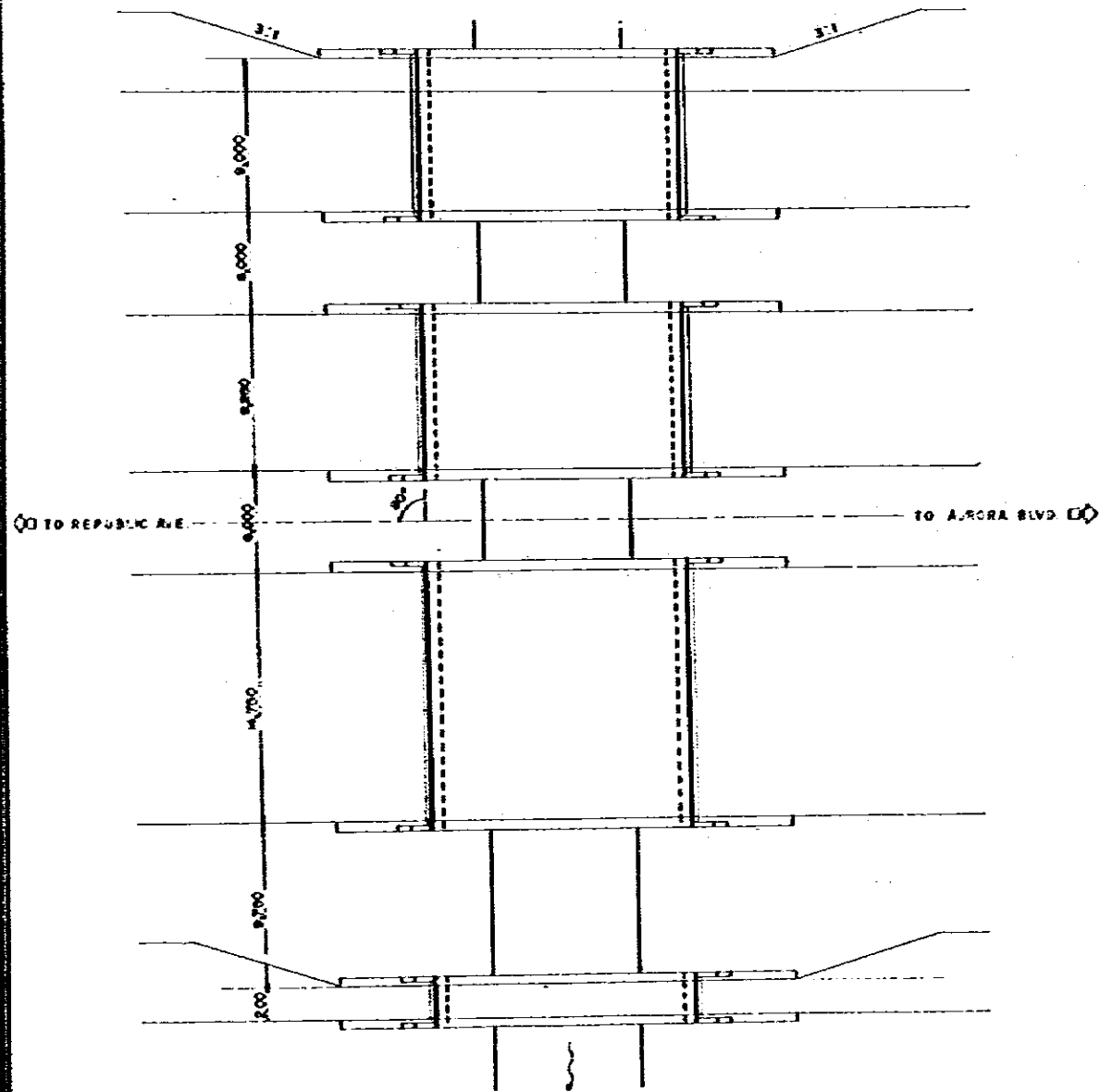

**CROSS SECTION**  
SCALE 1:300

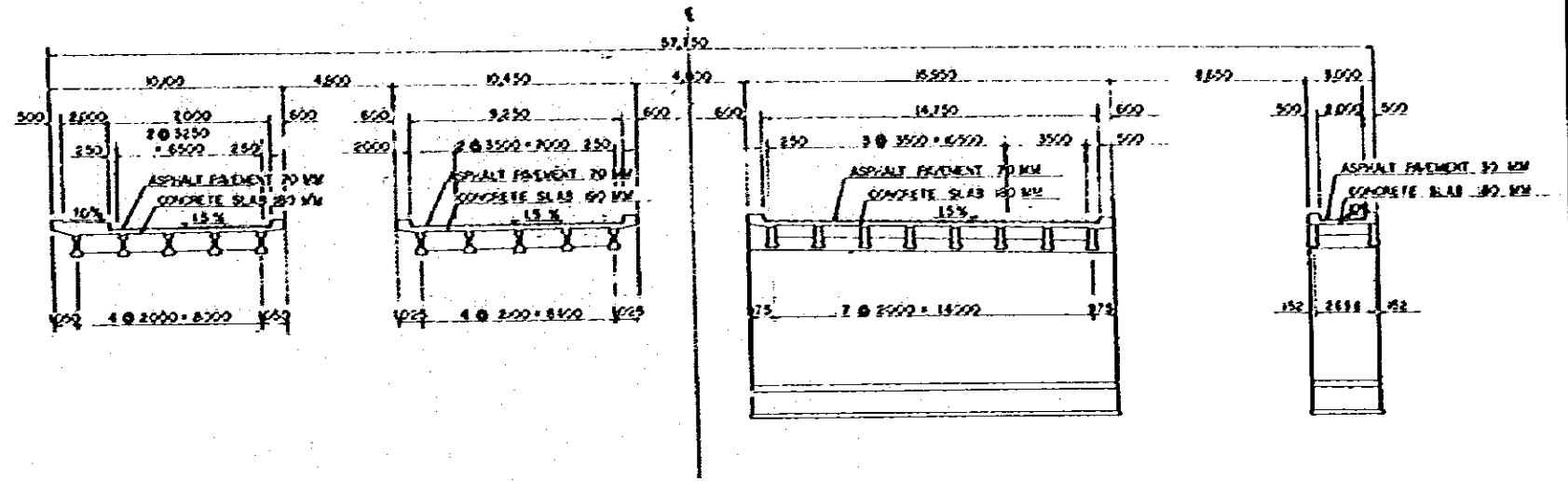

**LOCATION MAP**  
SCALE 1:50,000

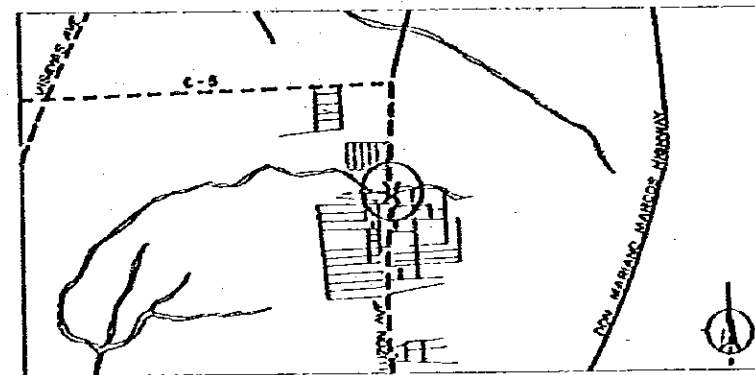

# C-5 BR-8

THE METRO MANILA OUTER MAJOR ROADS PROJECT (NORTHERN PACKAGE)		DRYING NO.
SCALE	C-5 BR-8	50/66
1:1000	PLAN AND ELEVATION	
1:200		

ELEVATION  
SCALE 1:1000

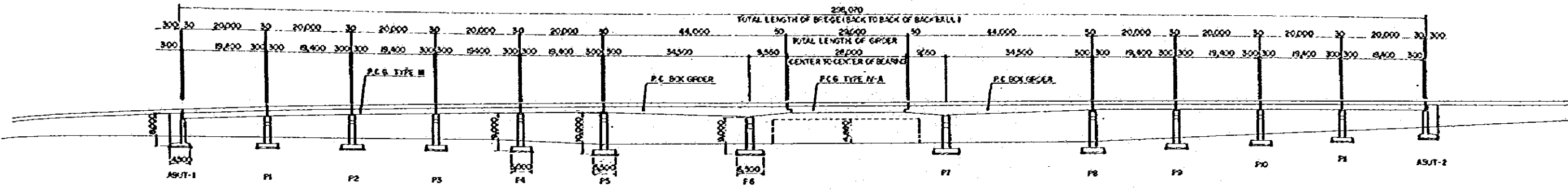

PLAN  
SCALE 1:1000

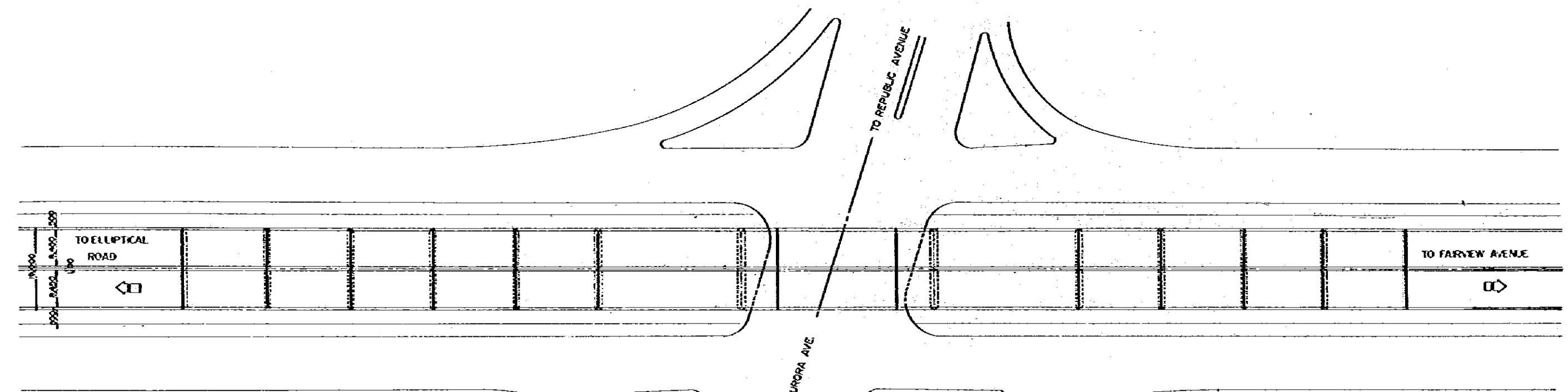

CROSS SECTION  
SCALE 1:200

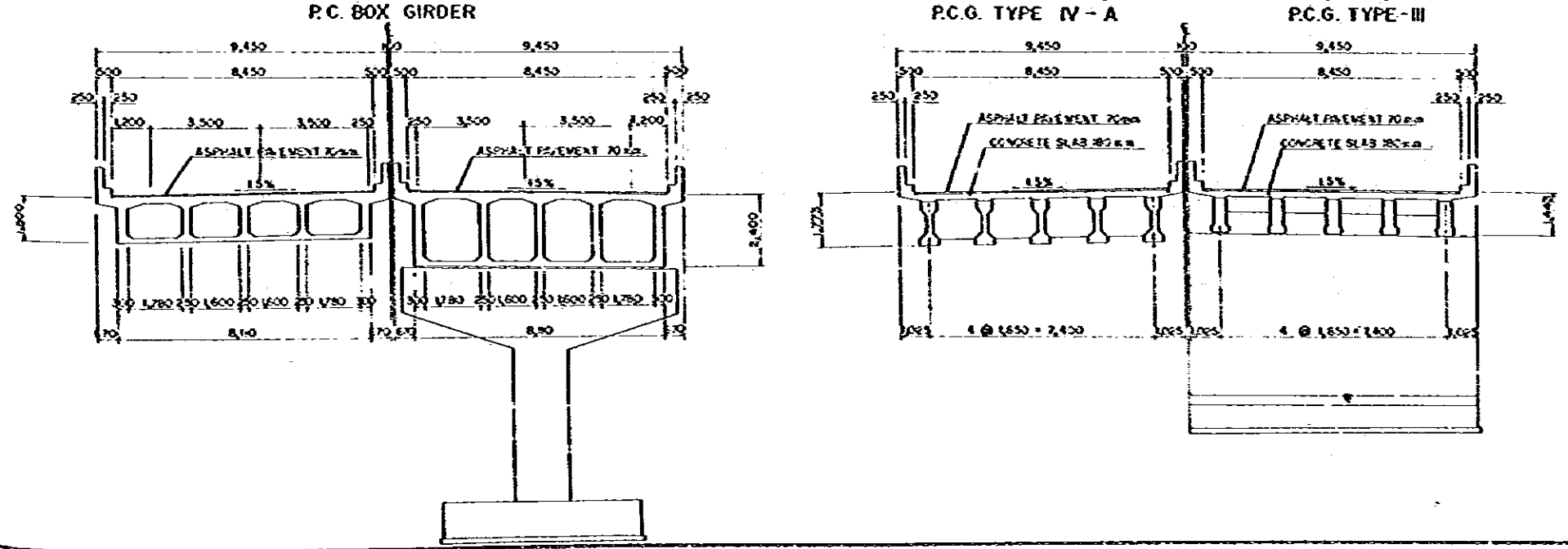

LOCATION MAP  
SCALE 1:50,000

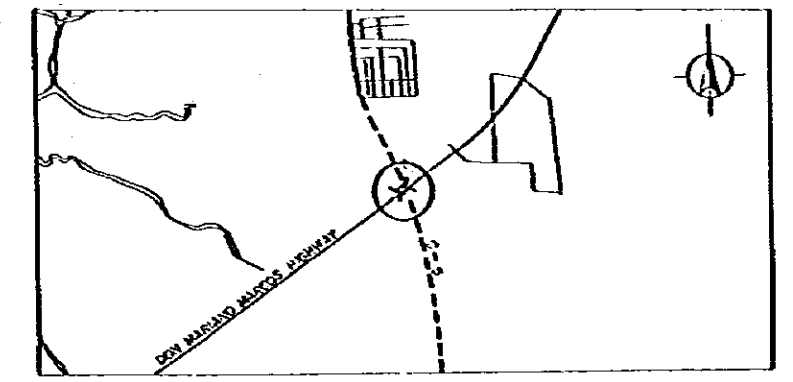

# C-5 BR - 9

ELEVATION  
SCALE 1:1000

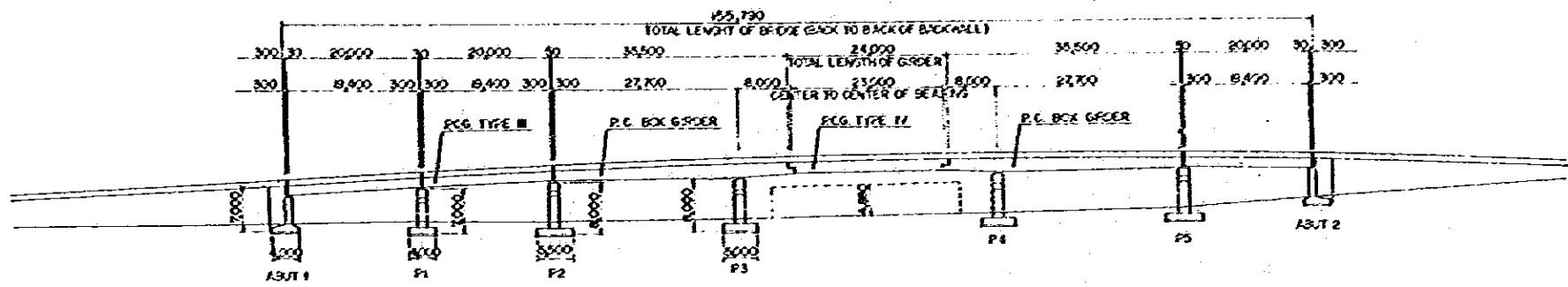

## PLAN

SCALE 1:1000

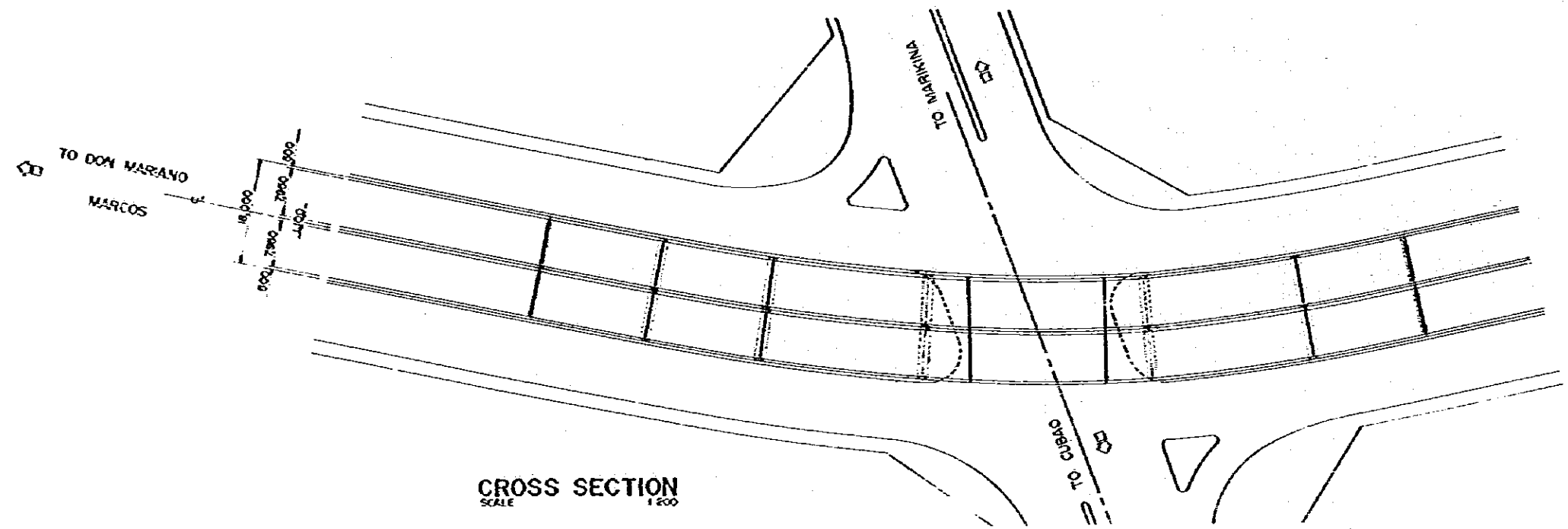

## CROSS SECTION

SCALE 1:200

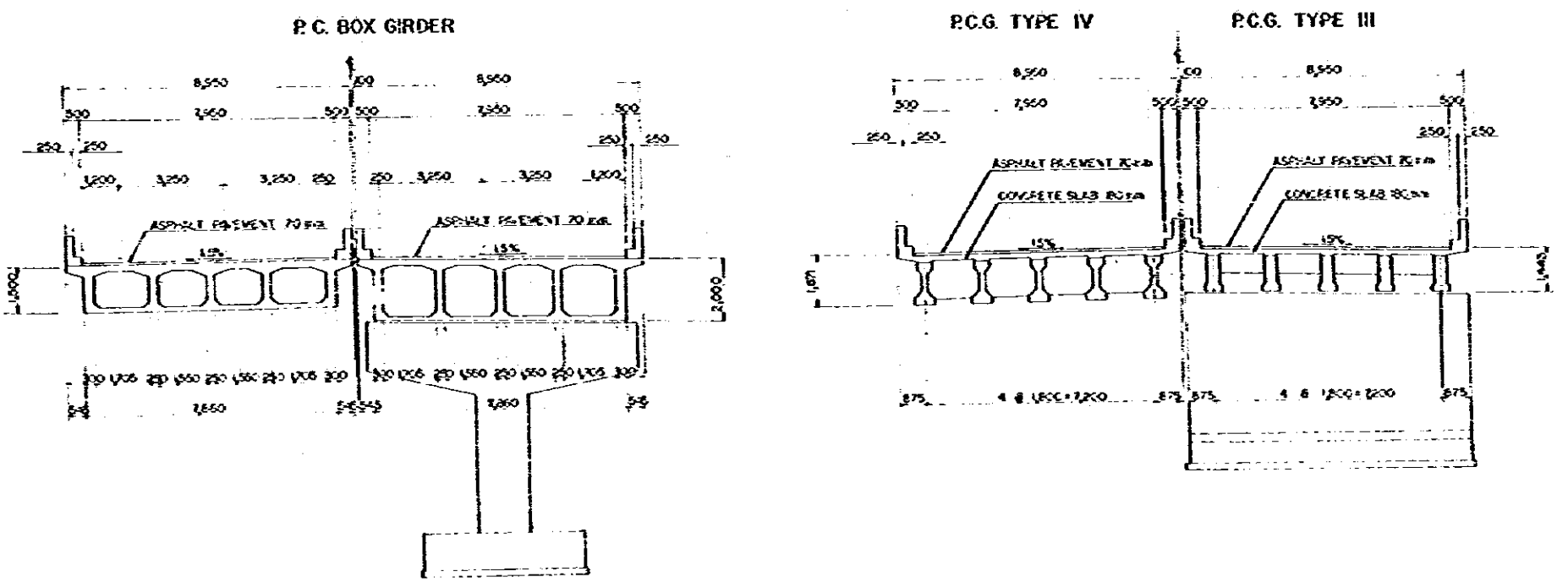

## LOCATION MAP

SCALE 1:50,000

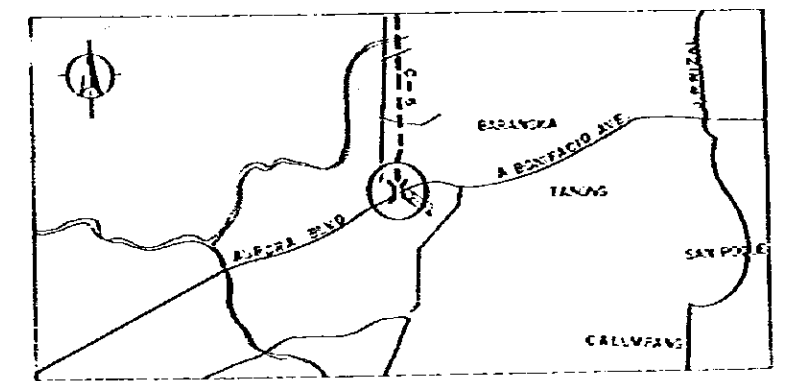

# C-5 BOX-1

THE METRO MANILA OUTER MAJOR ROADS PROJECT (NORTHERN PACKAGE 1)  
 SCALE 1:400  
 C-5 BOX-1  
 PLAN AND ELEVATION  
 DRAWING NO. 62/66

**ELEVATION**  
SCALE 1:400

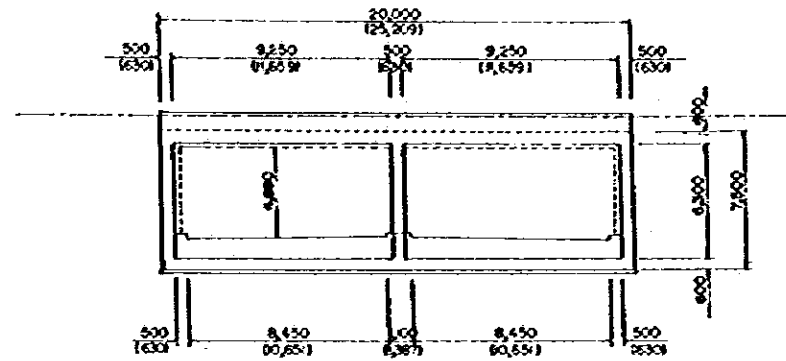

NOTE:  
( ) INDICATES SREW LENGTH

**CROSS SECTION**  
SCALE 1:400

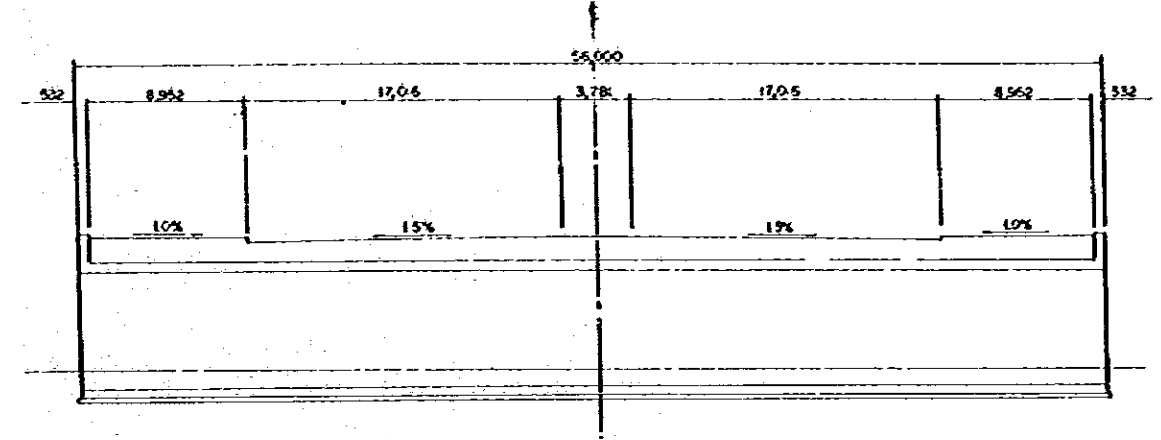

**PLAN**  
SCALE 1:400

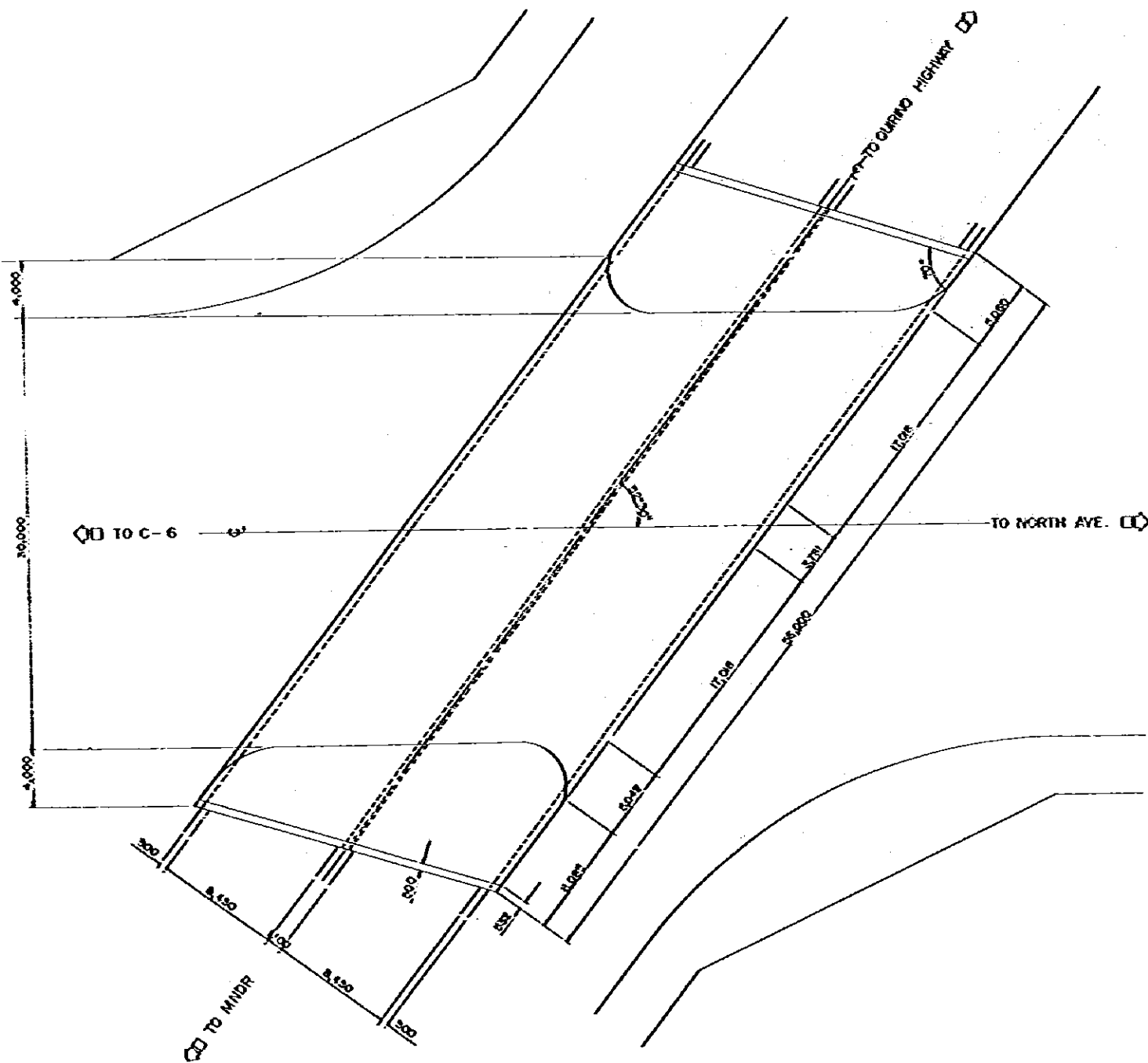

**LOCATION MAP**  
SCALE 1:50,000

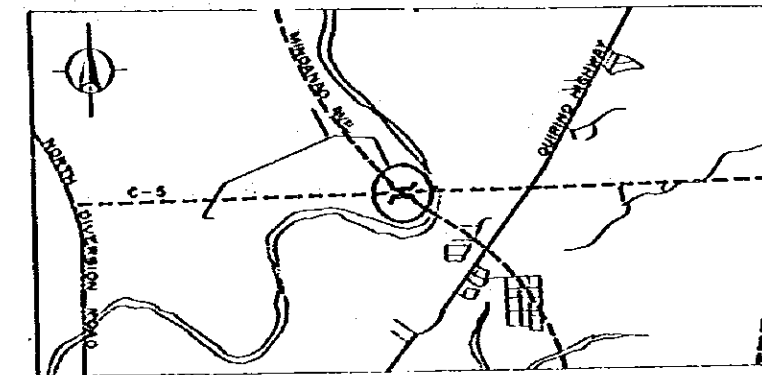

# C-5 BOX-2

THE METRO MANILA OUTER MAJOR ROADS PROJECT (NORTHERN PACKAGE)		
SCALE 1:400	C-5 BOX-2 PLAN AND ELEVATION	DESIGN NO. 53/66

**ELEVATION**  
SCALE 1:400

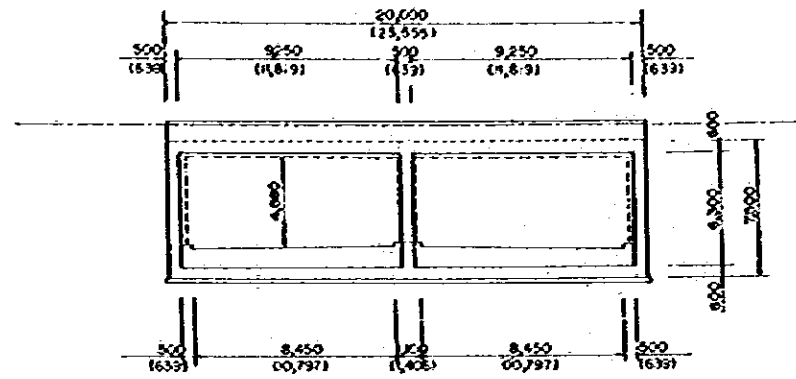

**CROSS SECTION**  
SCALE 1:400

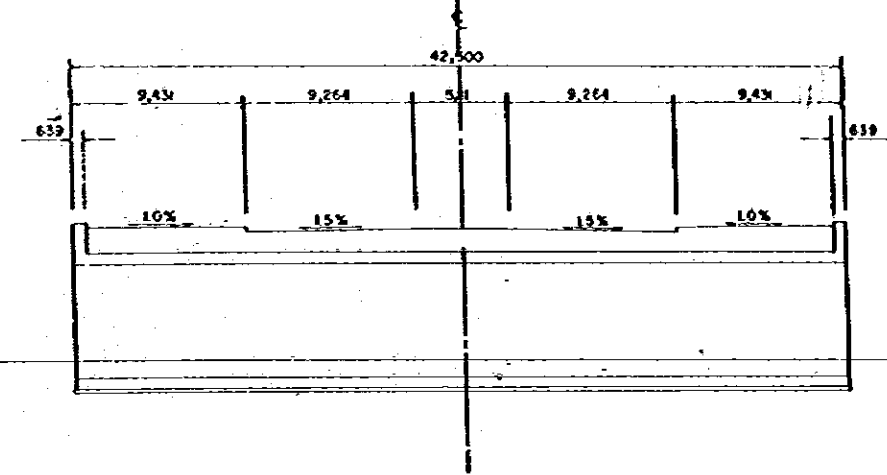

NOTE:  
E 1 INDICATES SKEW LENGTH

**PLAN**  
SCALE 1:400

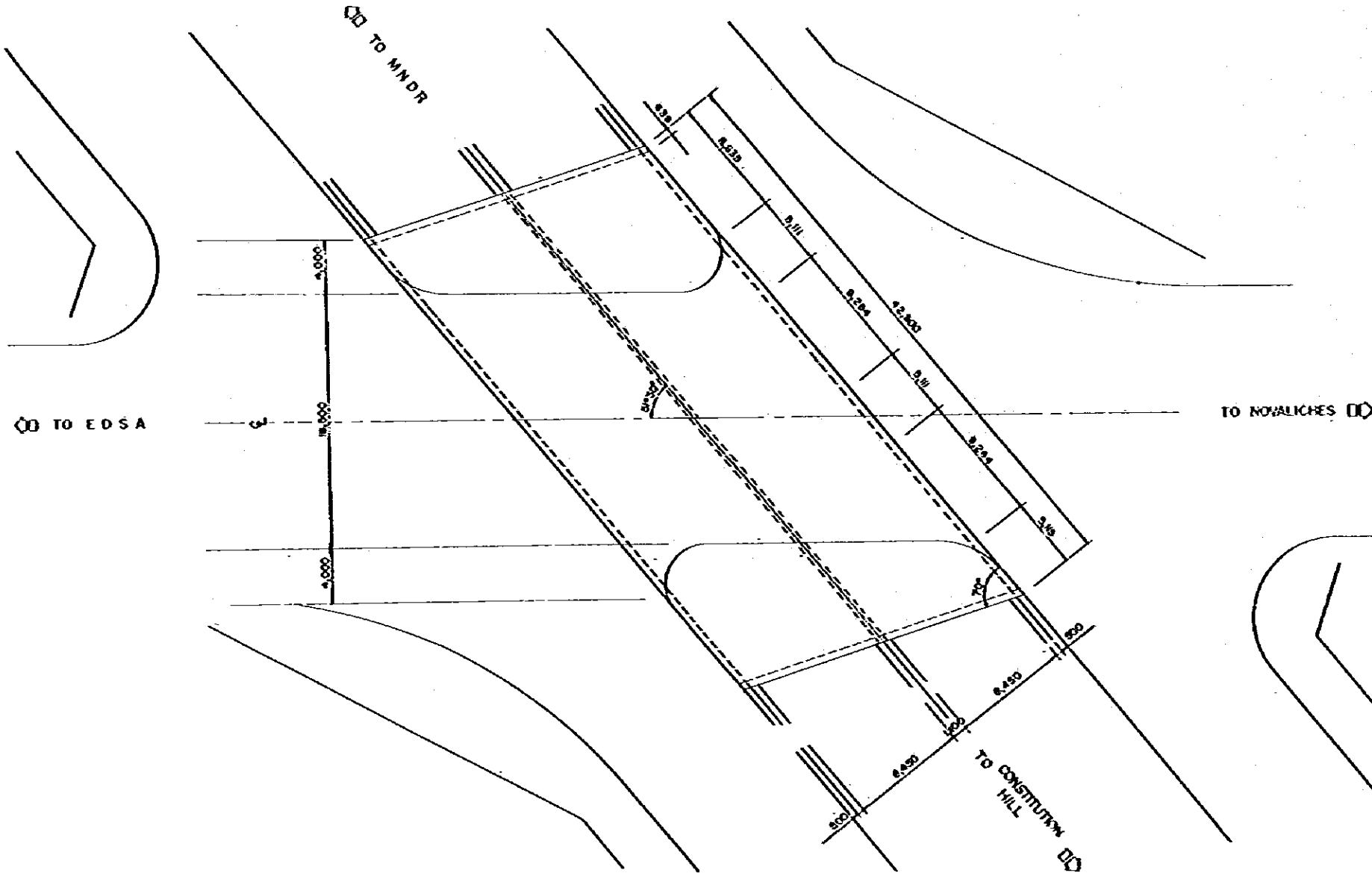

**LOCATION MAP**  
SCALE 1:80,000

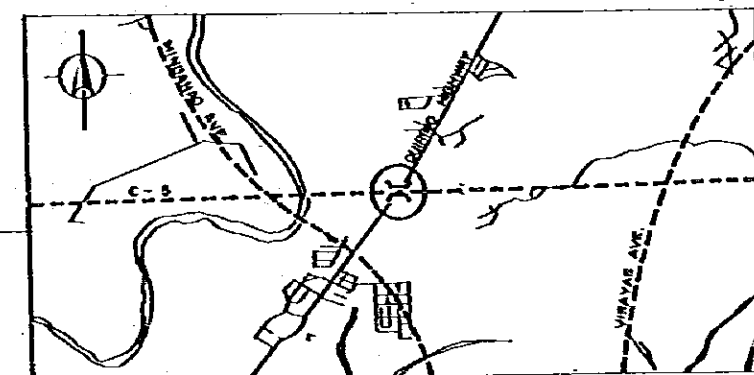

**C-6 BR-1**

**ELEVATION**  
SCALE 1:400

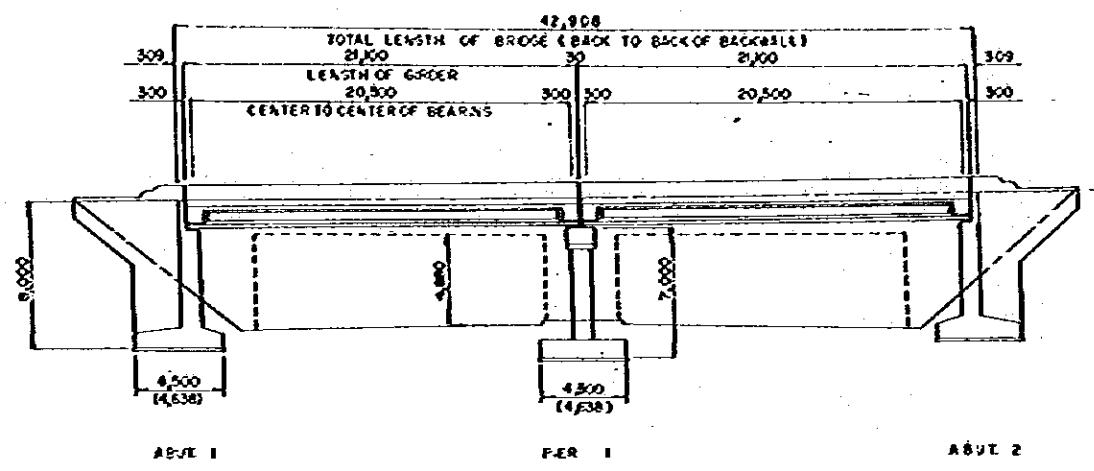

**CROSS SECTION**  
SCALE 1:200

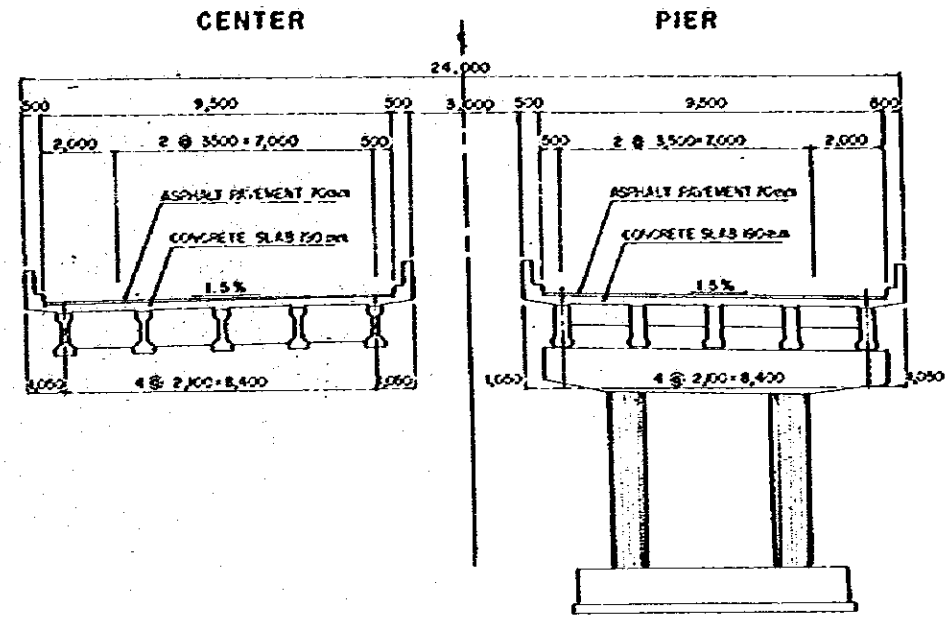

NOTE:  
 ( ) INDICATES S'W'F LENGTH

**PLAN**  
SCALE 1:400

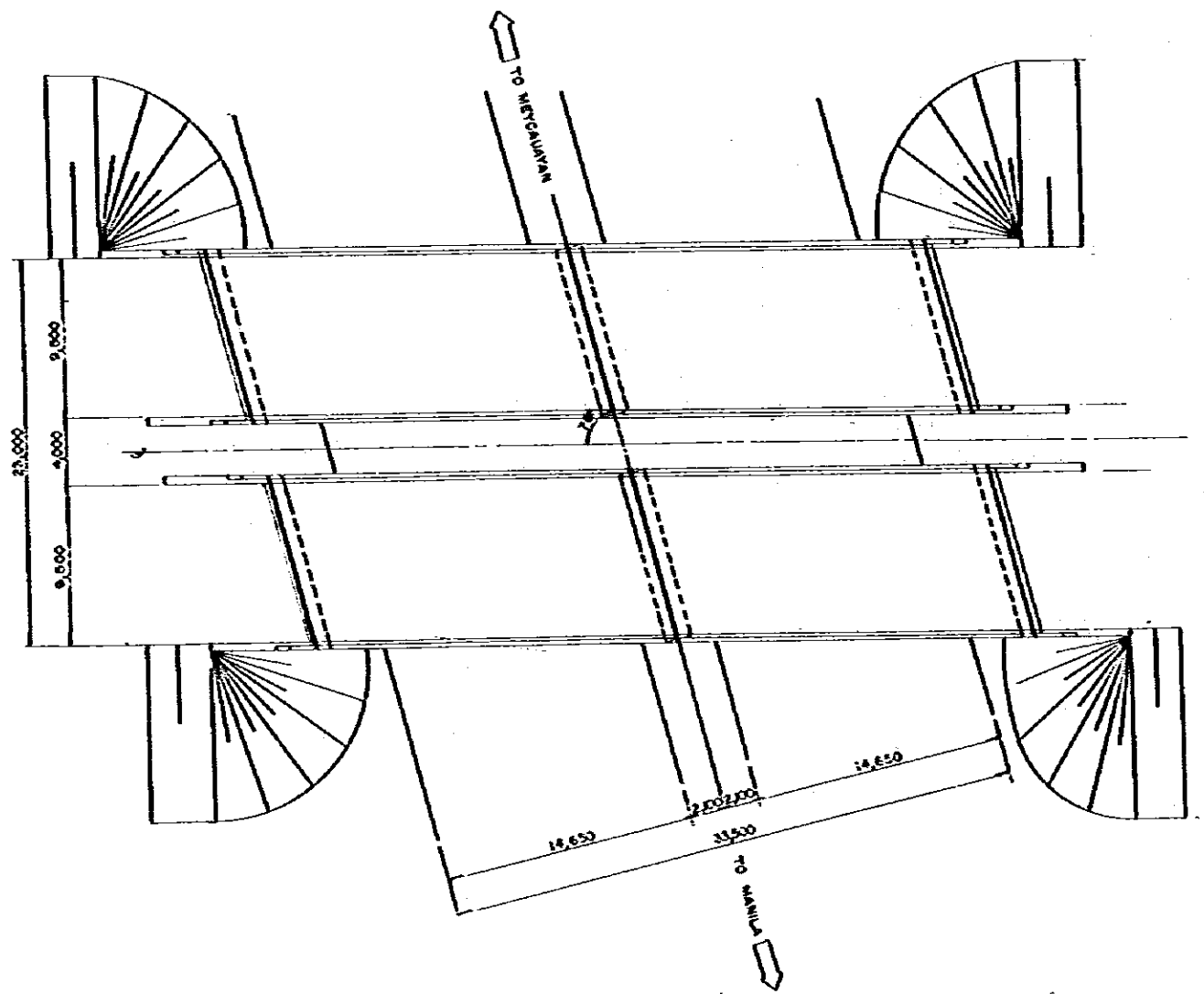

**KEY MAP**

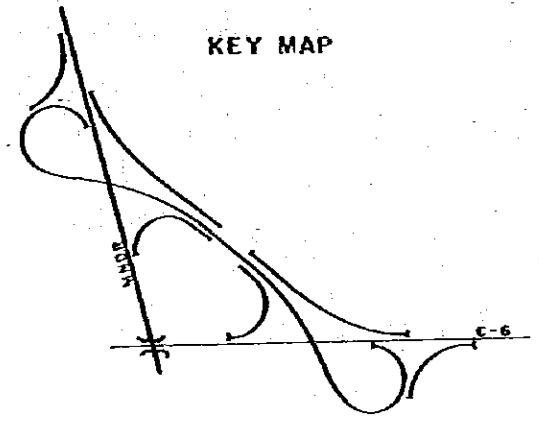

**LOCATION MAP**  
SCALE 1:50,000

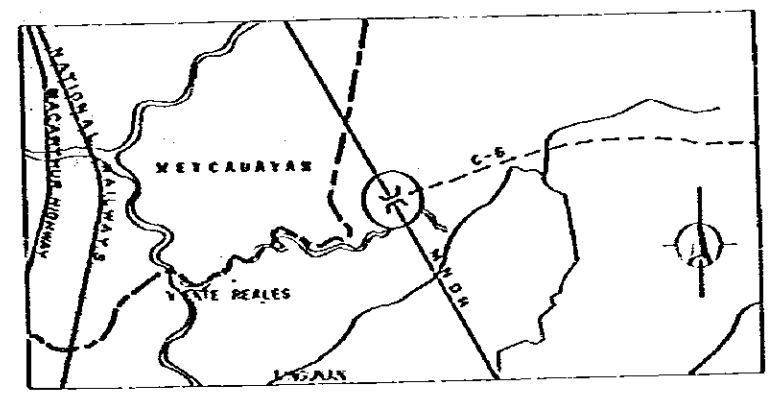

# C-6 BR-2

THE METRO MANILA OUTER MAJOR ROADS PROJECT (NORTHERN PACKAGE)

SCALE  
1:400  
1:200

C-6 BR-2  
PLAN AND ELEVATION

55/66

**ELEVATION**  
SCALE 1:400

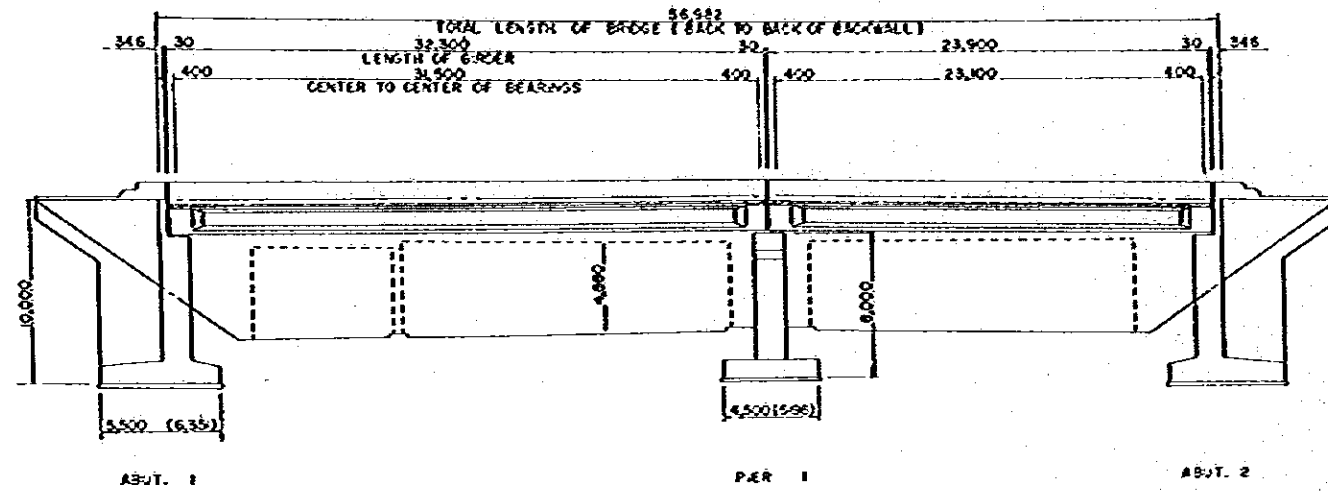

NOTE:  
E I INDICATES SHEW LENGTH

**CROSS SECTION**  
SCALE 1:200

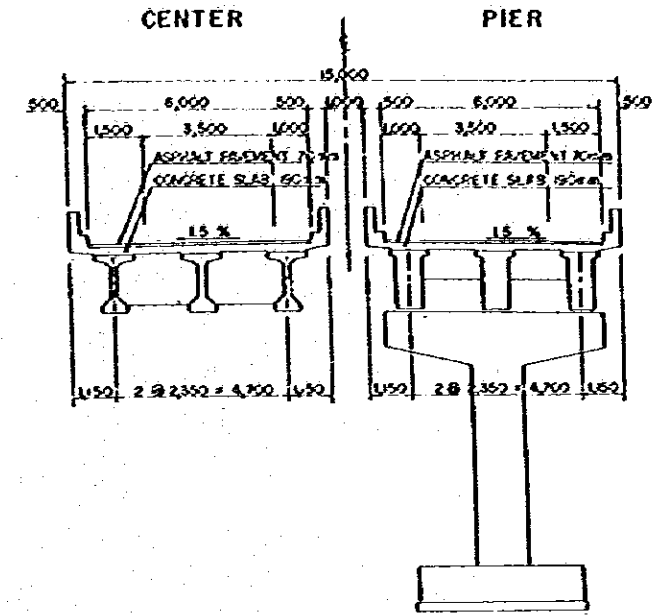

**KEY MAP**

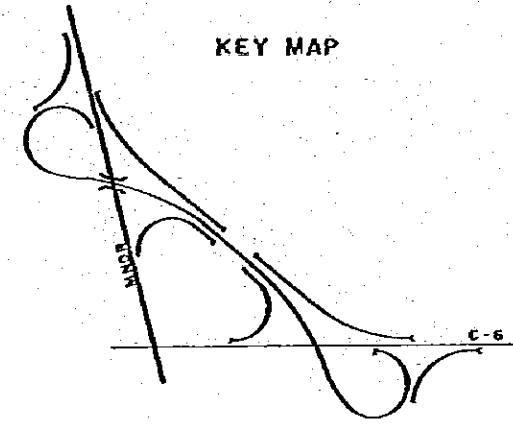

**PLAN**  
SCALE 1:400

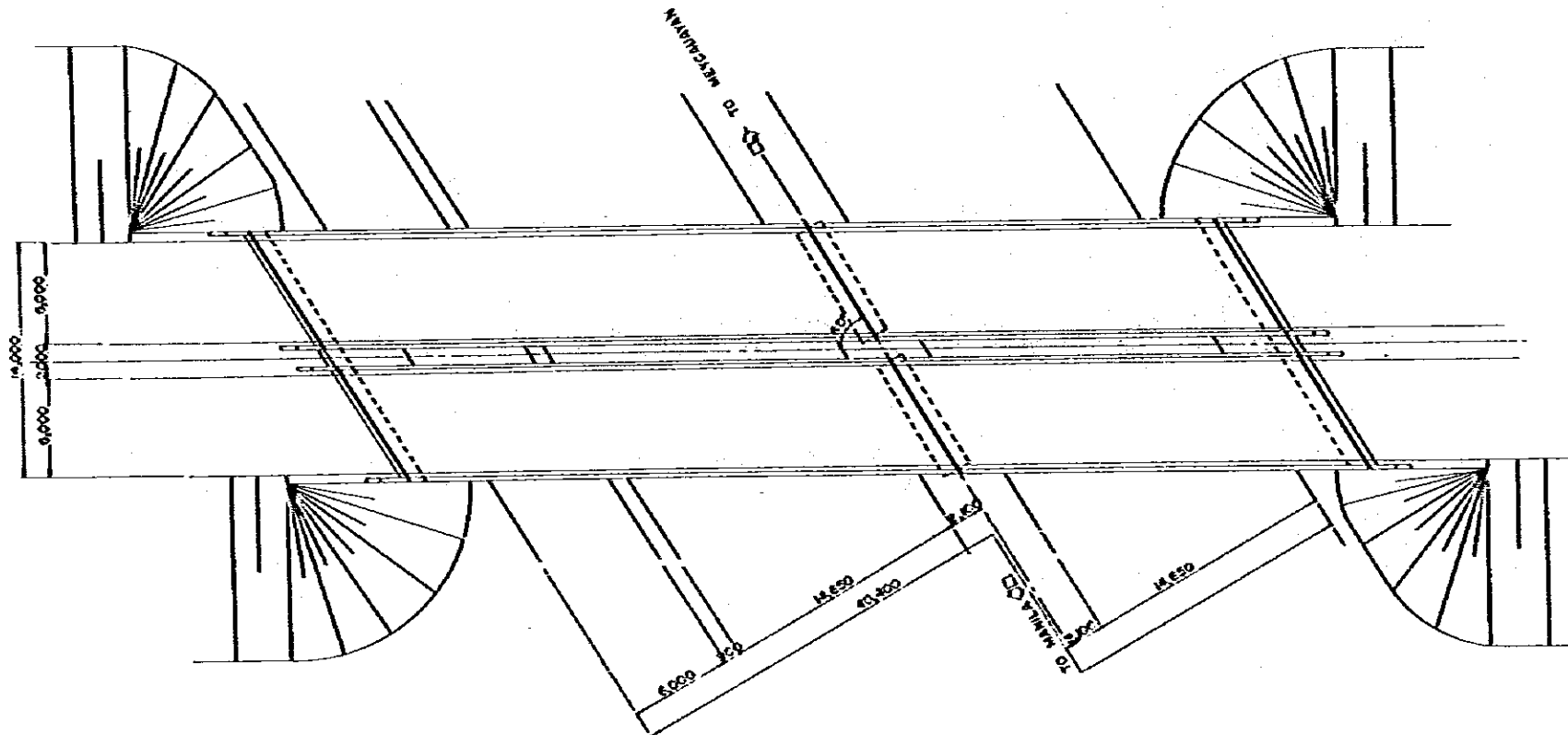

**LOCATION MAP**  
SCALE 1:50,000





**C-6 BR-3**

**ELEVATION**  
SCALE: E 400

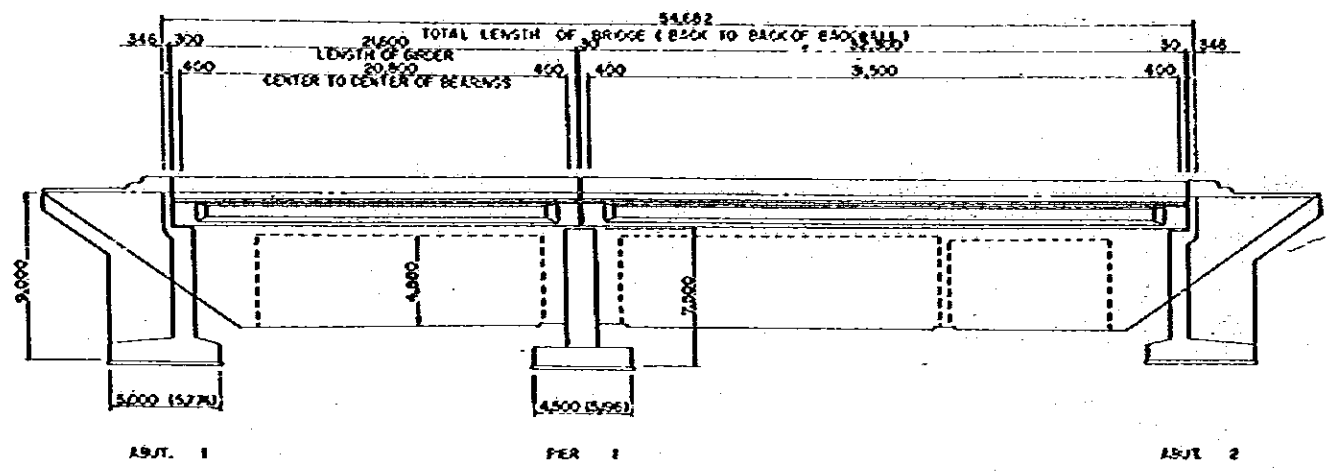

**CROSS SECTION**  
SCALE: F 200

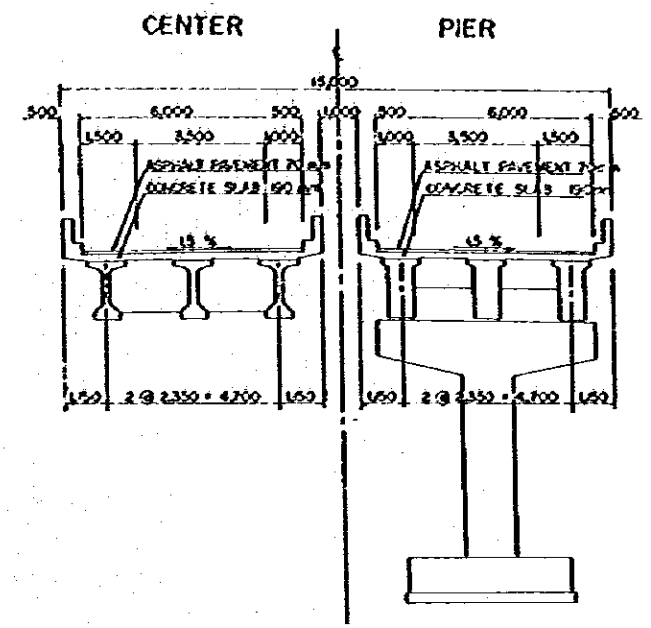

NOTE:  
( ) INDICATES SKEW LENGTH

**PLAN**  
SCALE: E 400

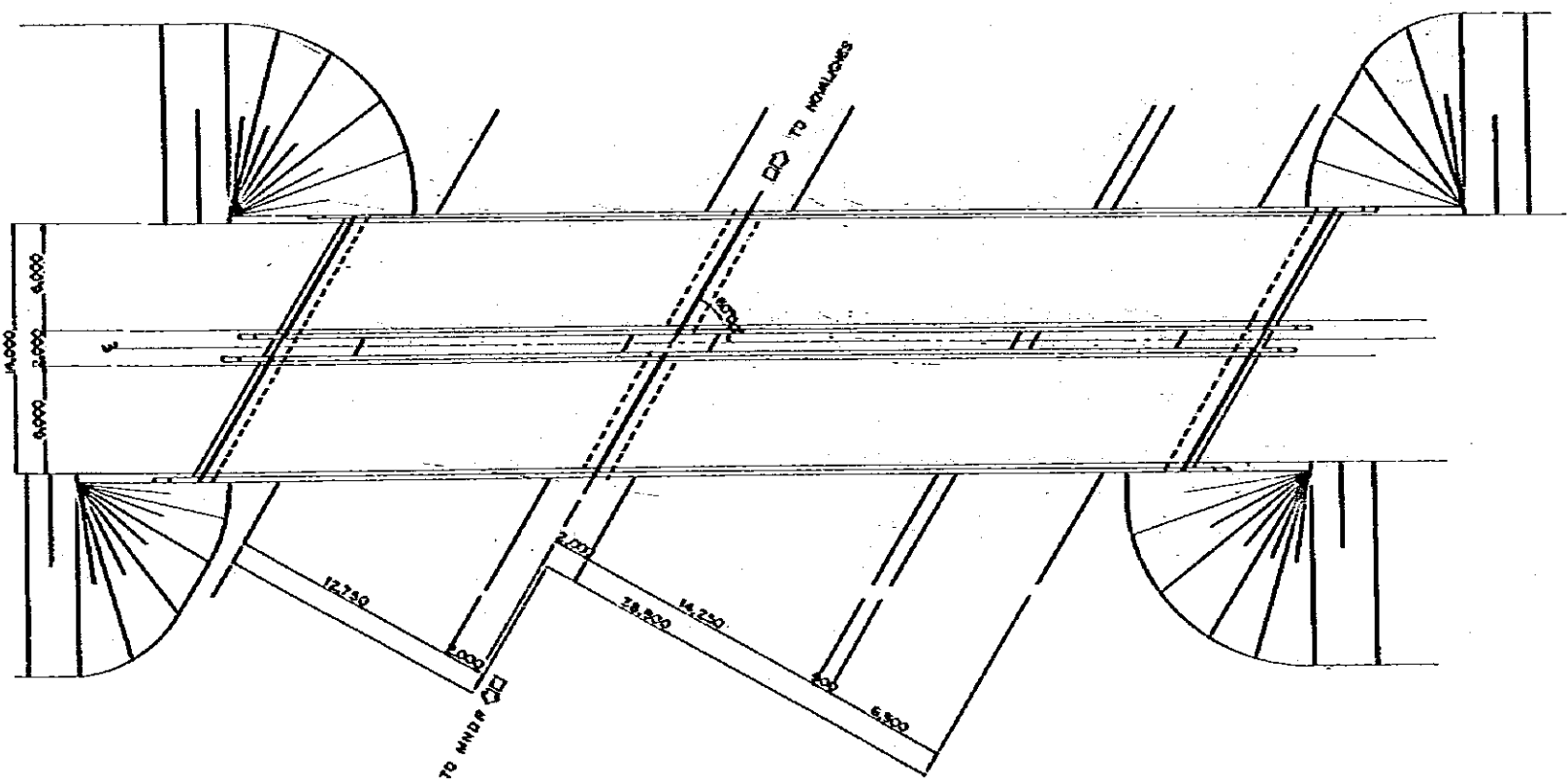

**LOCATION MAP**  
SCALE: 1:10,000

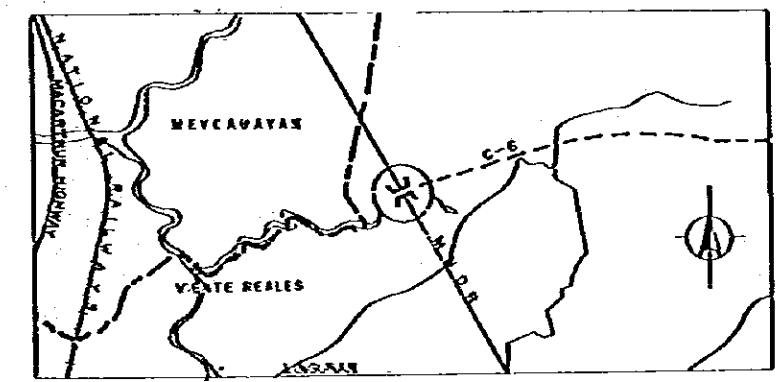

**KEY MAP**

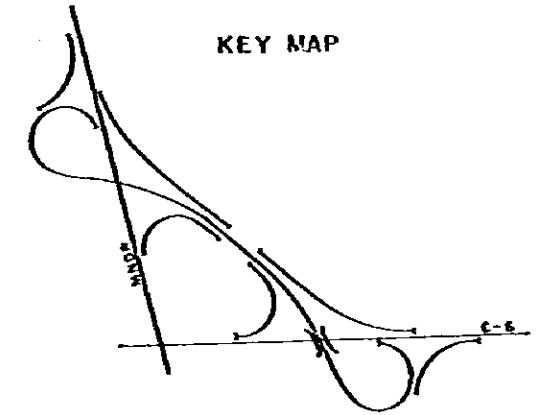

**C-6 BR-4**  
ELEVATION  
SCALE 1/1000

THE METRO MANILA OUTER MAJOR ROADS PROJECT (NORTHERN PACKAGE)		DESIGN NO.
SCALE	C-6 BR-4	57/66
1/1000	PLAN AND ELEVATION	
1/200		

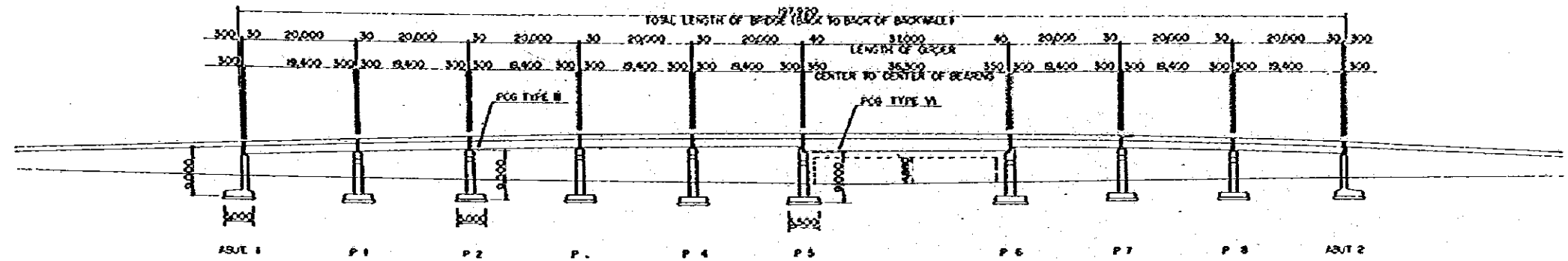

**P L A N**  
SCALE 1/1000

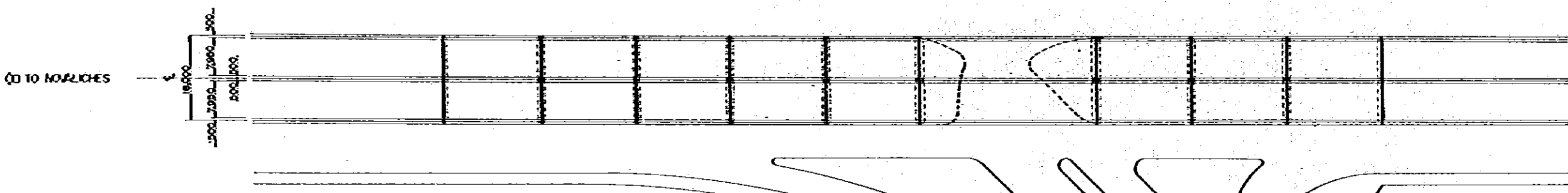

**CROSS SECTION**  
SCALE 1/200

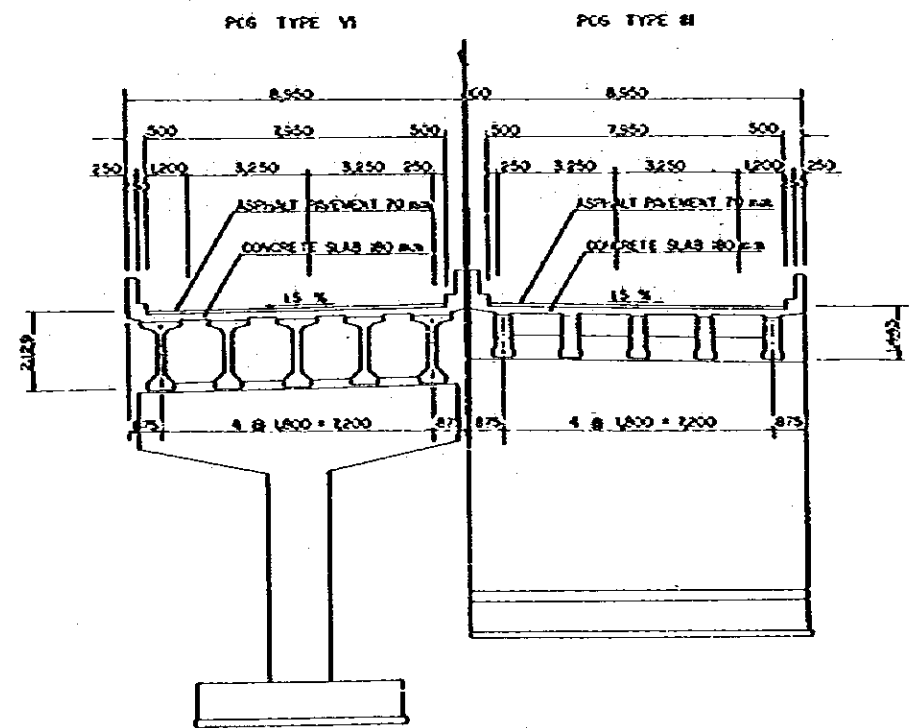

**LOCATION MAP**  
SCALE 1/50,000

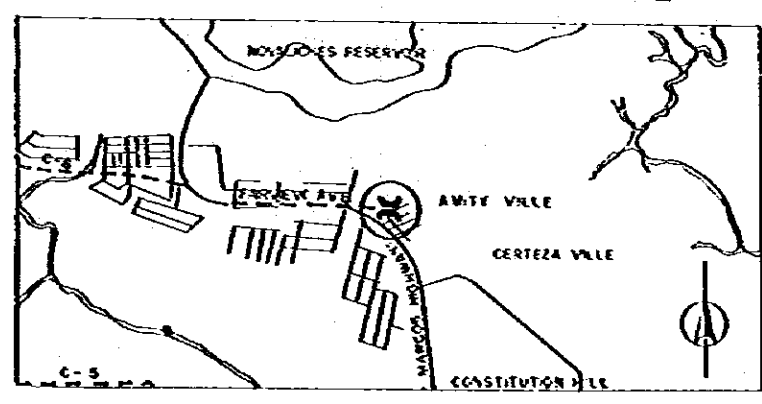

# MINDANAO AVENUE BR-1

THE METRO MANILA OUTER MAJOR ROADS PROJECT (NORTHERN PACKAGE)  
 SCALE: 1:400  
 1:800  
**MINDANAO AVENUE BR-1**  
 PLAN AND ELEVATION  
 58/66

**ELEVATION**  
SCALE 1:400

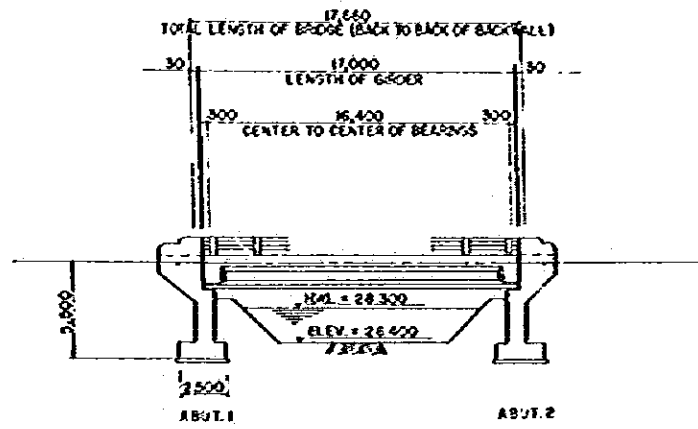

**CROSS SECTION**  
SCALE 1:200

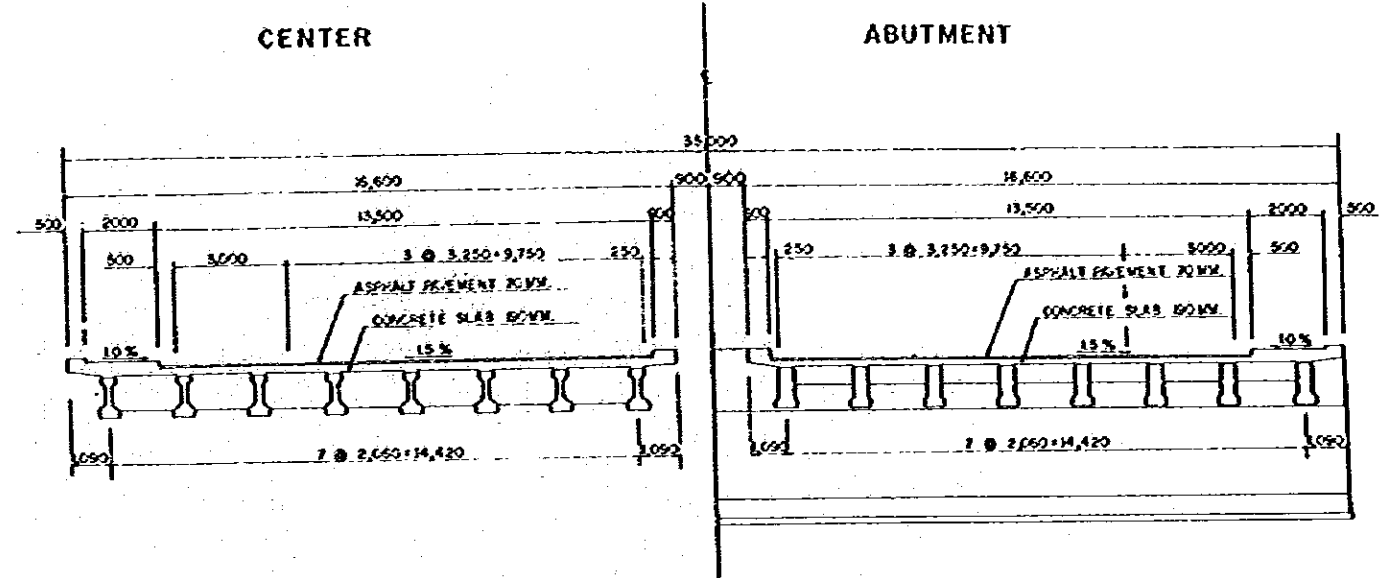

**PLAN**  
SCALE 1:400

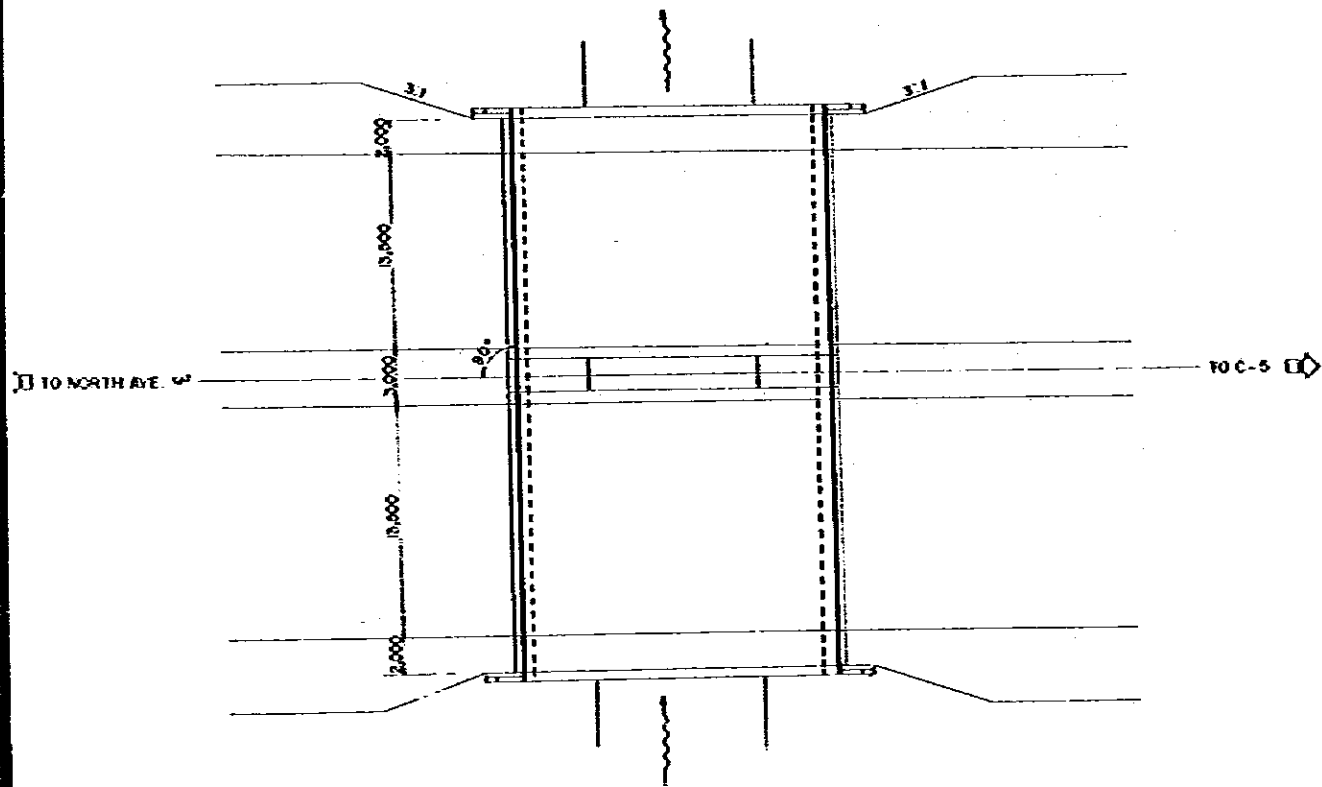

**LOCATION MAP**  
SCALE: 1:50,000

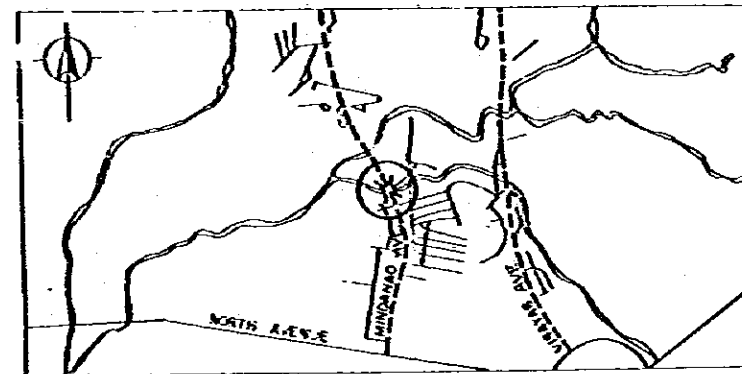

# MINDANAO AVENUE BR-2

THE METRO MANILA OUTER MAJOR ROADS PROJECT (NORTHERN PACKAGE I)  
 SCALE 1:400 1:200  
**MINDANAO AVENUE BR-2**  
 PLAN AND ELEVATION  
 05/29/73  
 69/66

**ELEVATION**  
SCALE 1:400

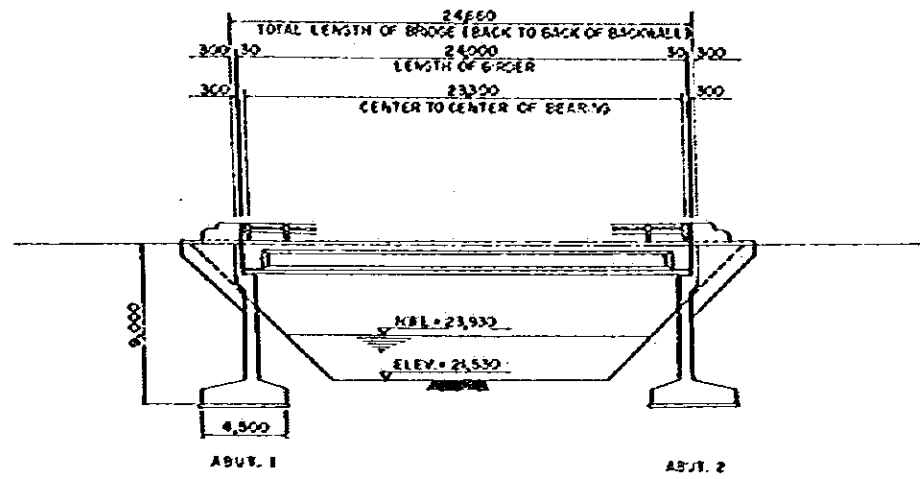

**CROSS SECTION**  
SCALE 1:200

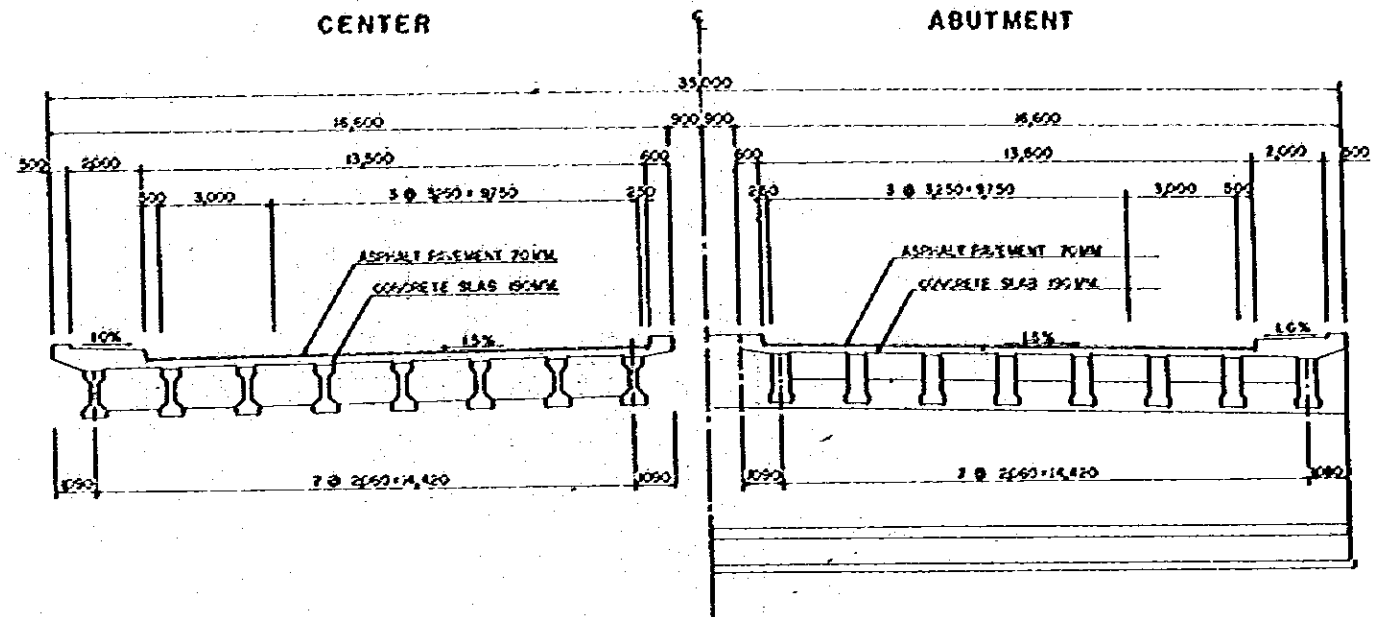

**PLAN**  
SCALE 1:400

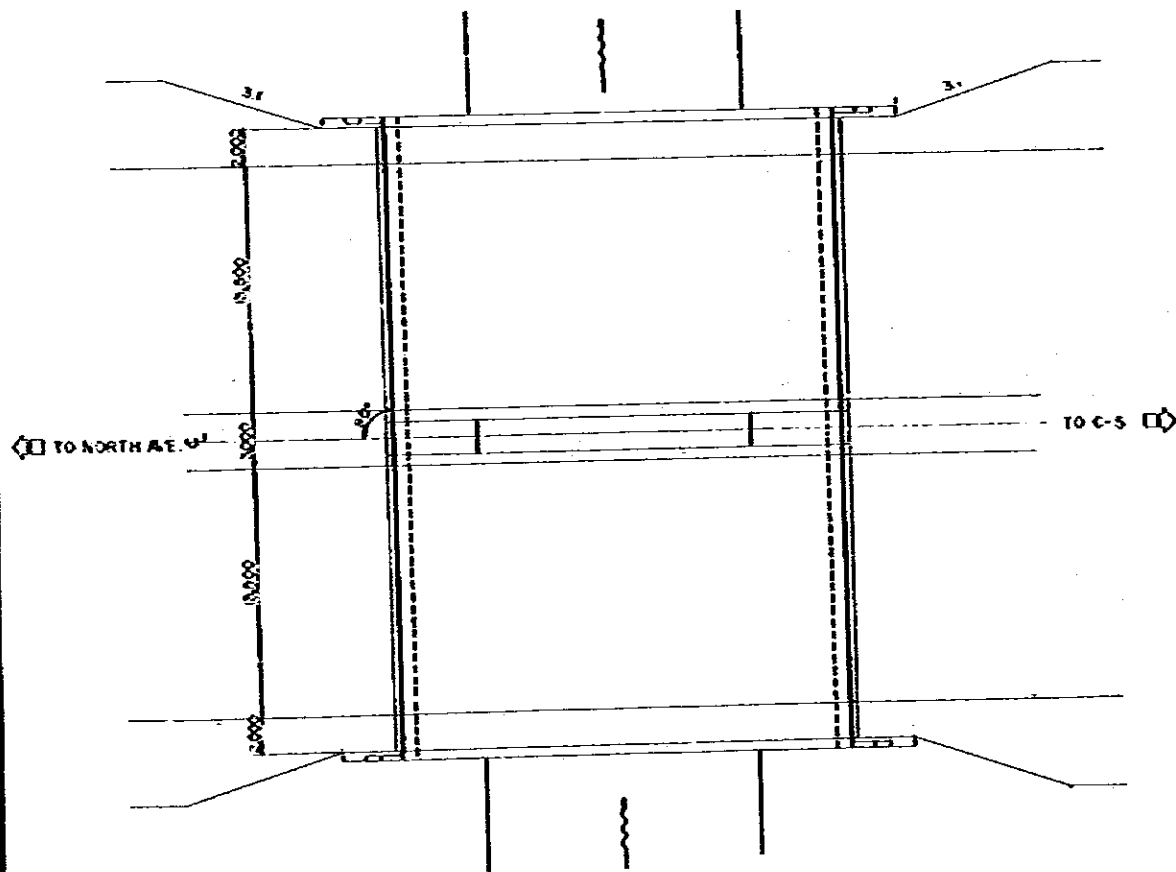

**LOCATION MAP**  
SCALE 1:50000

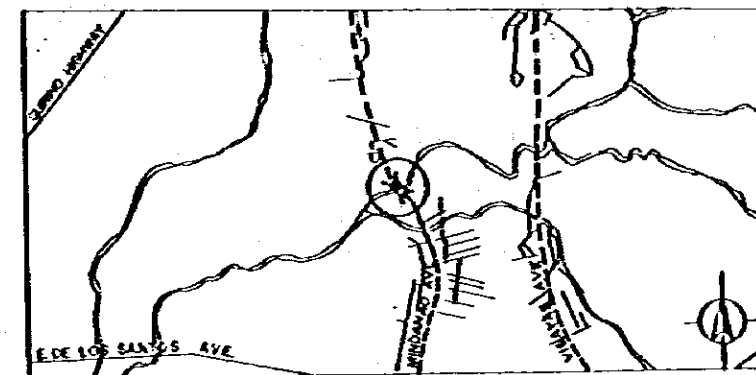

# MINDANAO AVENUE BR-3

THE METRO MANILA OUTER MAJOR ROADS PROJECT (NORTHERN PACKAGE)  
 SCALE 1:800  
 1:800  
 1:800  
**MINDANAO AVENUE BR-3**  
**PLAN AND ELEVATION**  
 DRAWING NO. 60/66

**ELEVATION**  
SCALE 1:400

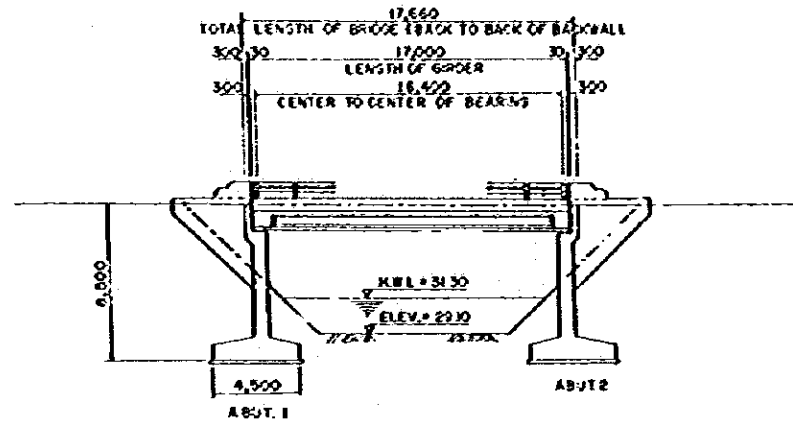

**CROSS SECTION**  
SCALE 1:800

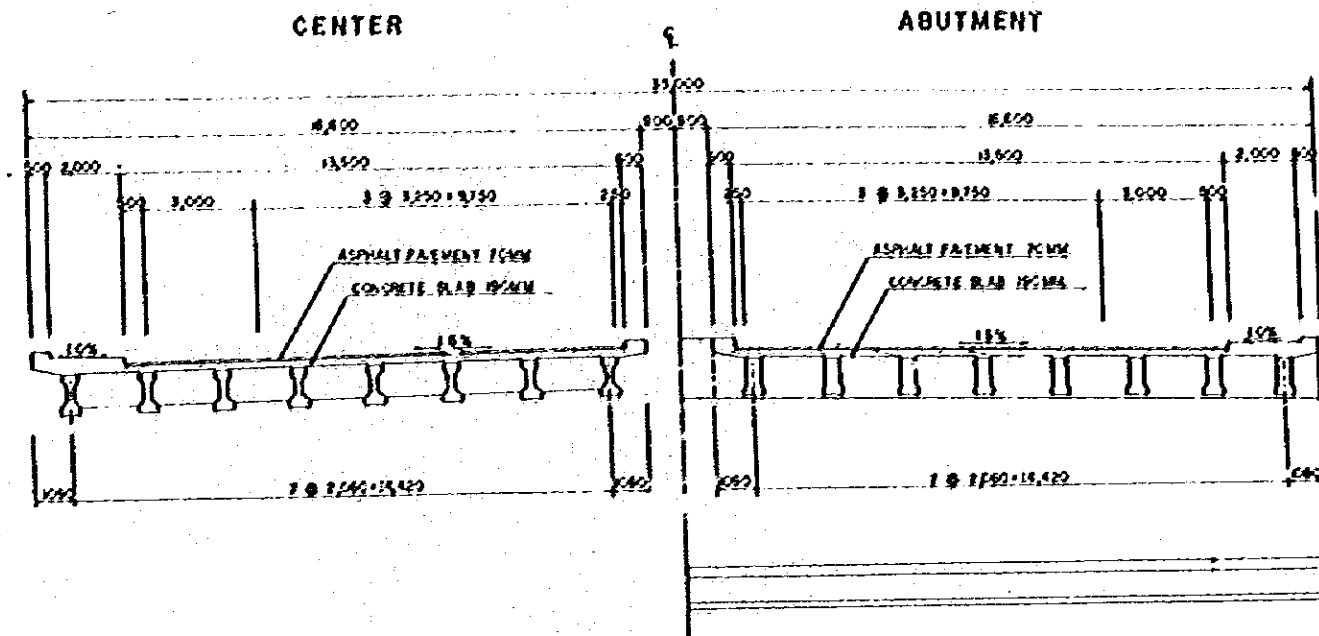

**PLAN**  
SCALE 1:400

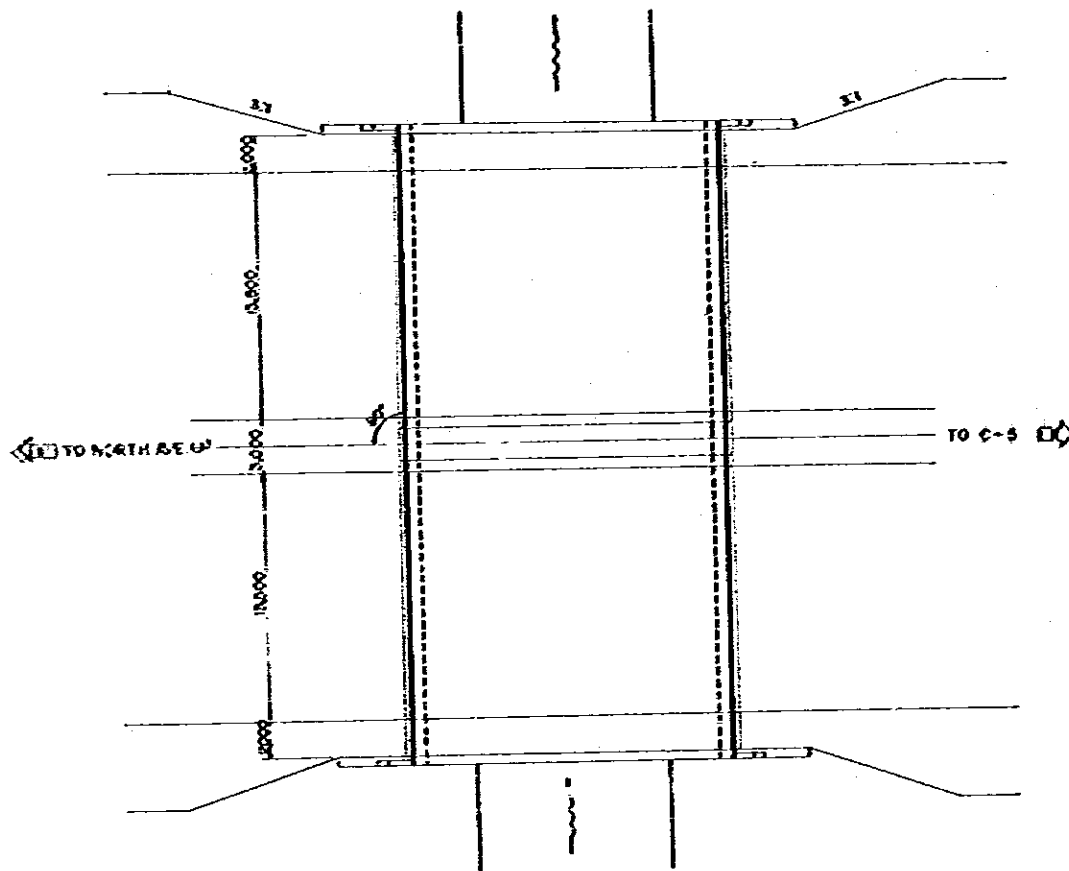

**LOCATION MAP**  
SCALE 1:25,000

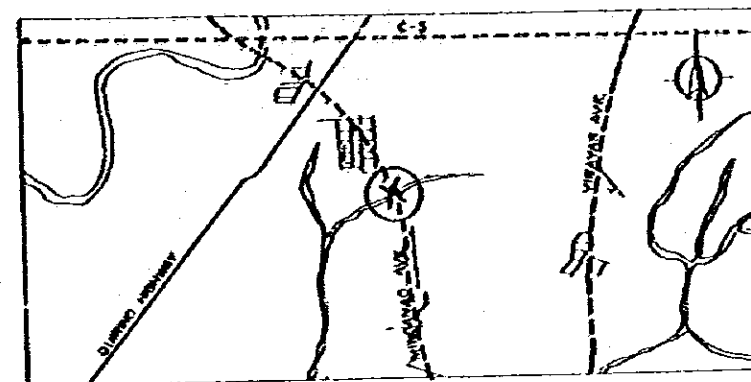

# MINDANAO AVENUE BR-4

**ELEVATION**  
SCALE 1:400

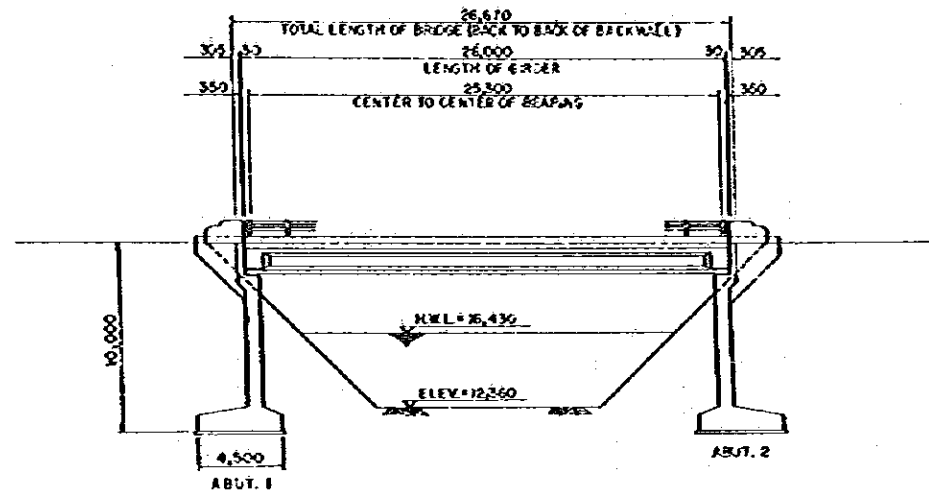

**CROSS SECTION**  
SCALE 1:200

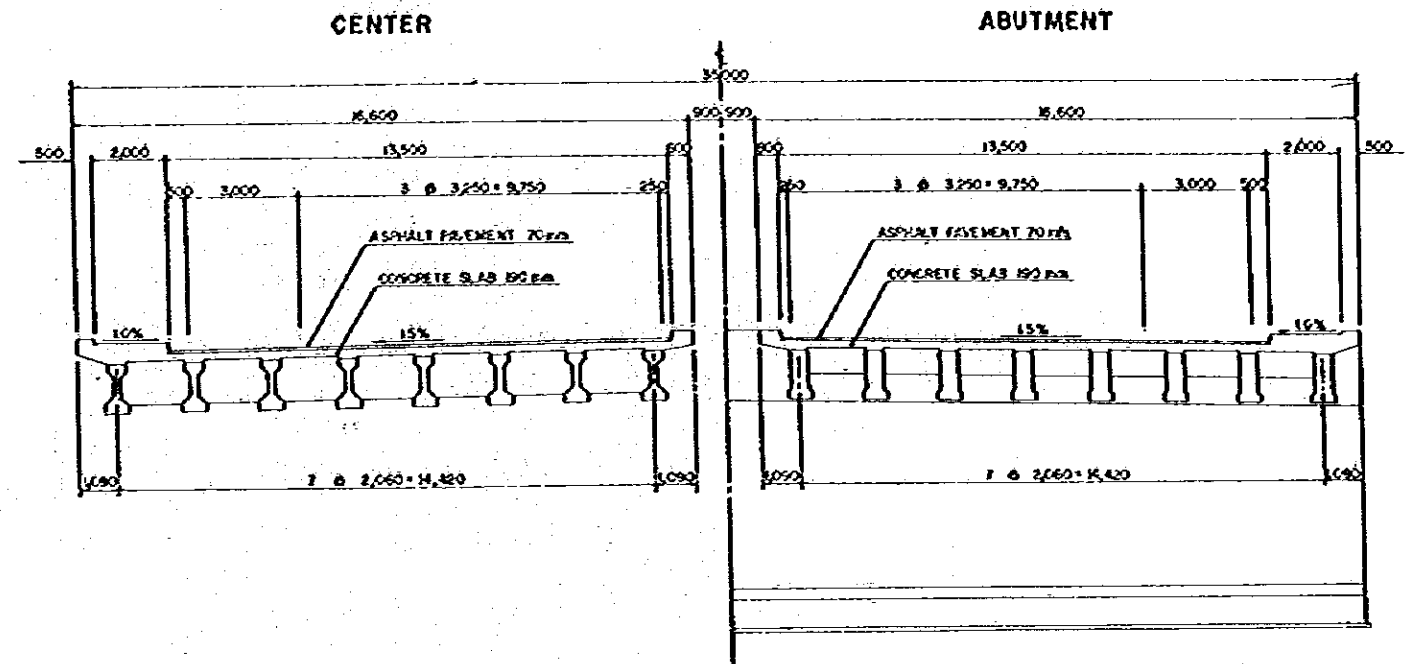

**PLAN**  
SCALE 1:400

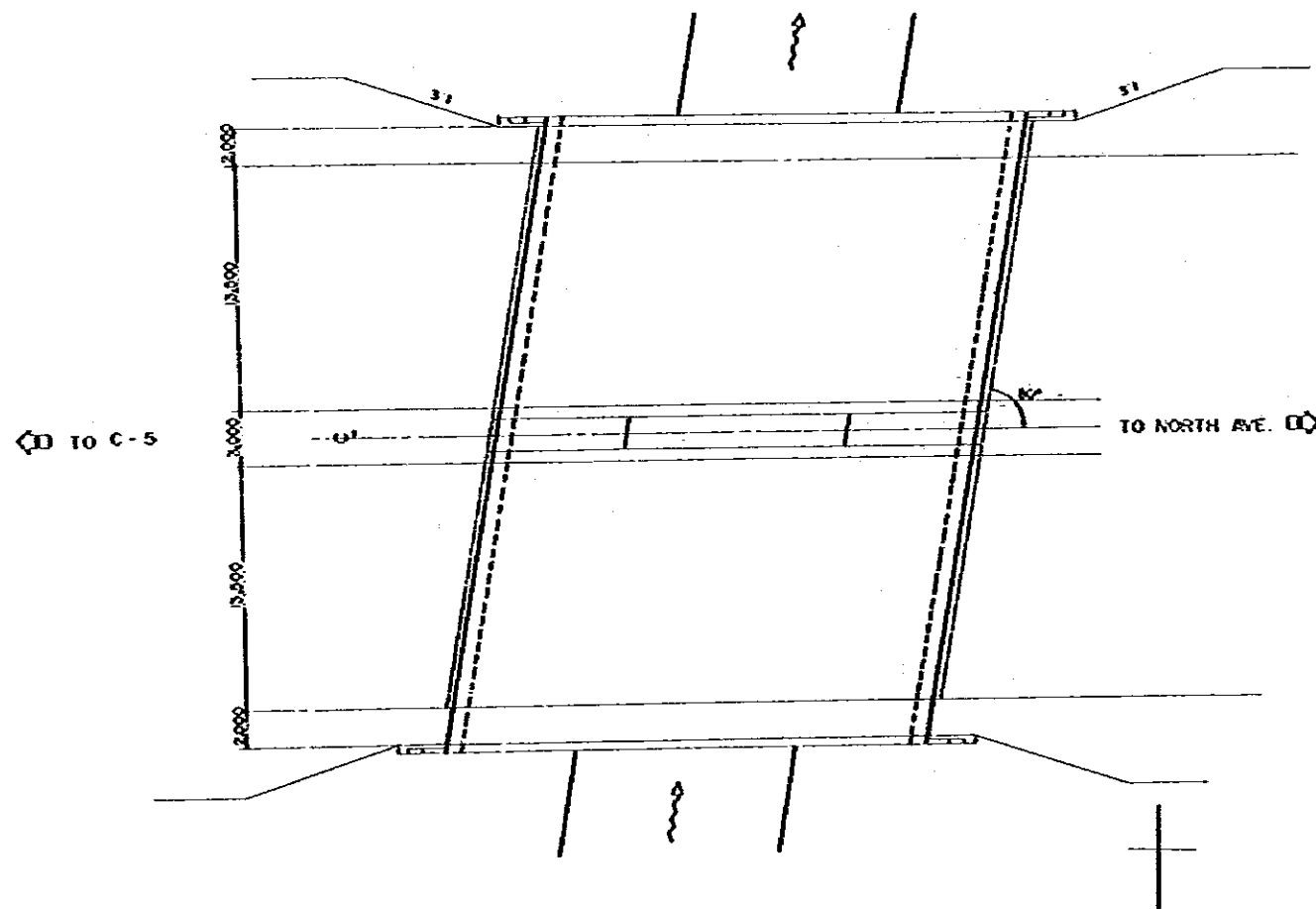

**LOCATION MAP**  
SCALE 1:50,000

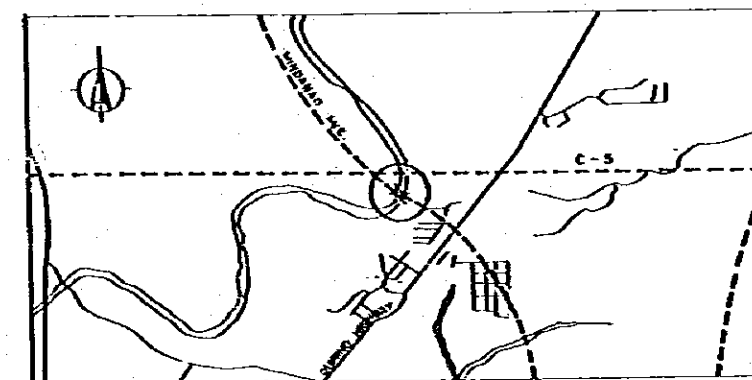

# VISAYAS AVENUE BR-1

**ELEVATION**  
SCALE 1:400

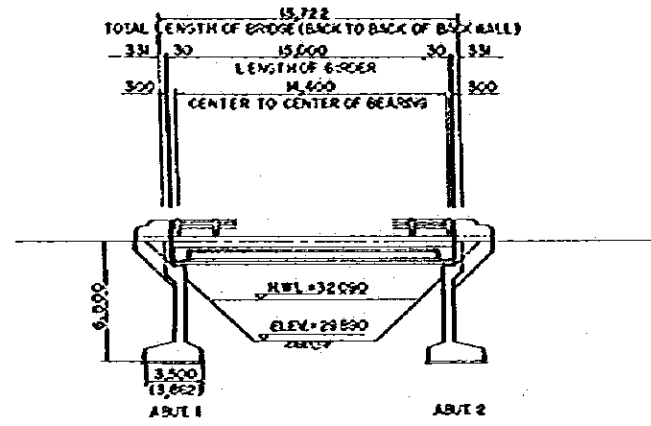

NOTE:  
 1) INDICATES SKEW LENGTH

**CROSS SECTION**  
SCALE 1:200

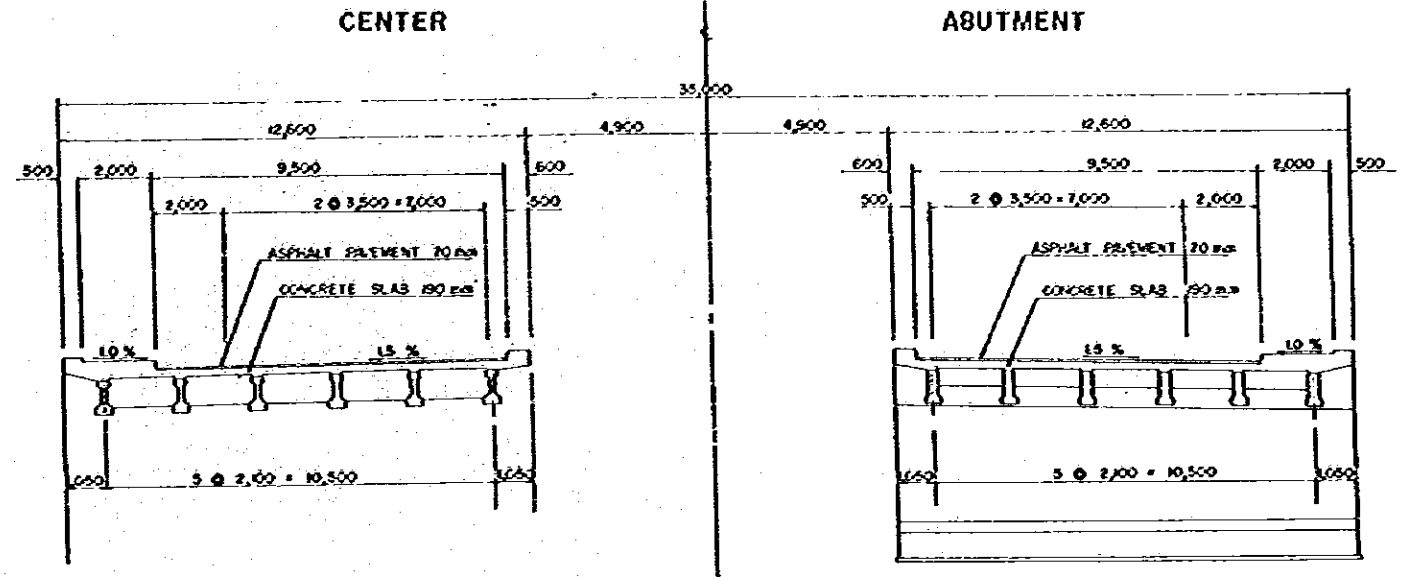

**PLAN**  
SCALE 1:400

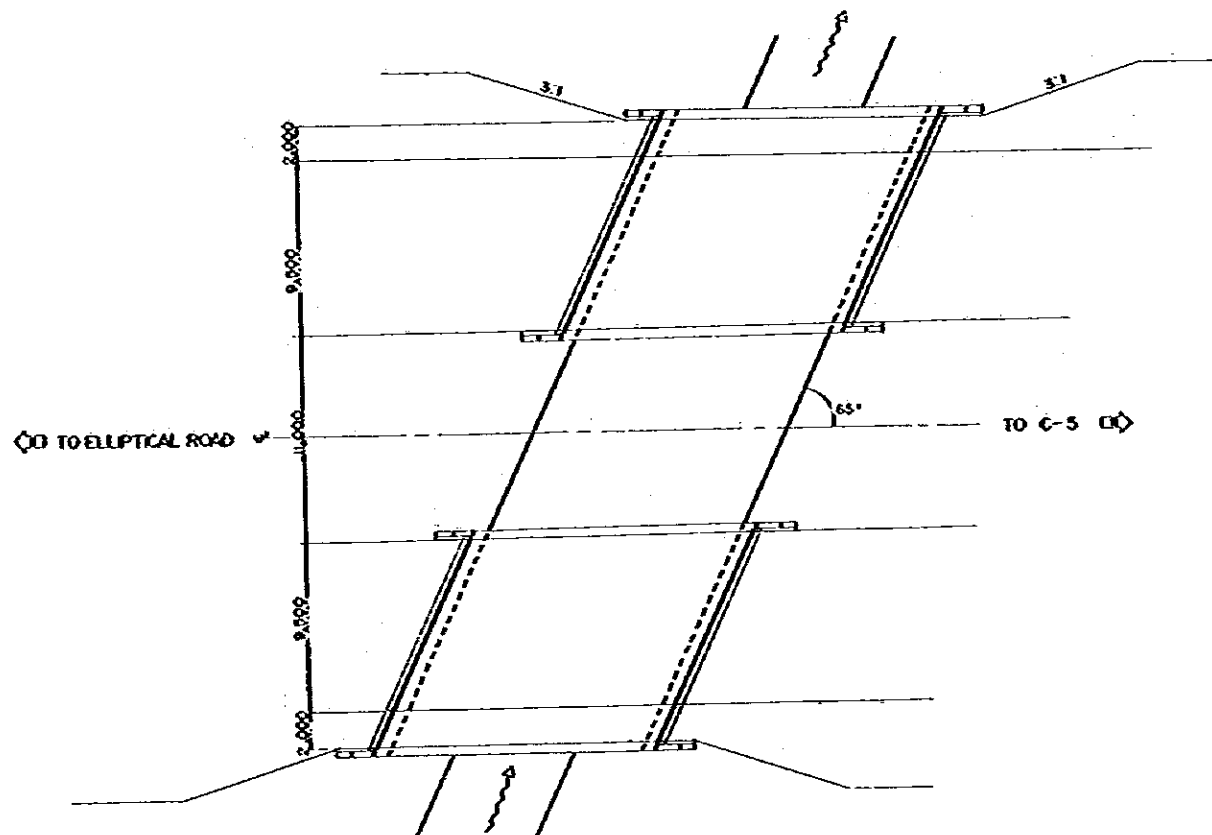

**LOCATION MAP**  
SCALE 1:50,000

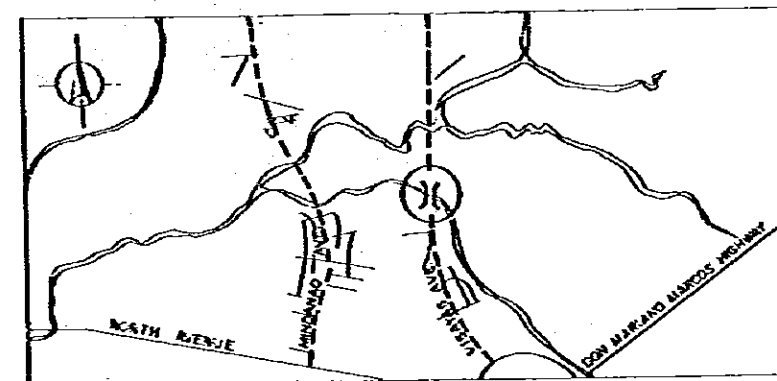

# VISAYAS AVENUE BR-2

THE METRO MANILA OUTER MAJOR ROADS PROJECT (NORTHERN PACKAGE)  
 SCALE 1:400 1:200  
**VISAYAS AVENUE BR-2**  
**PLAN AND ELEVATION**  
 DRAWING NO. 63/68

**ELEVATION**  
SCALE 1:400

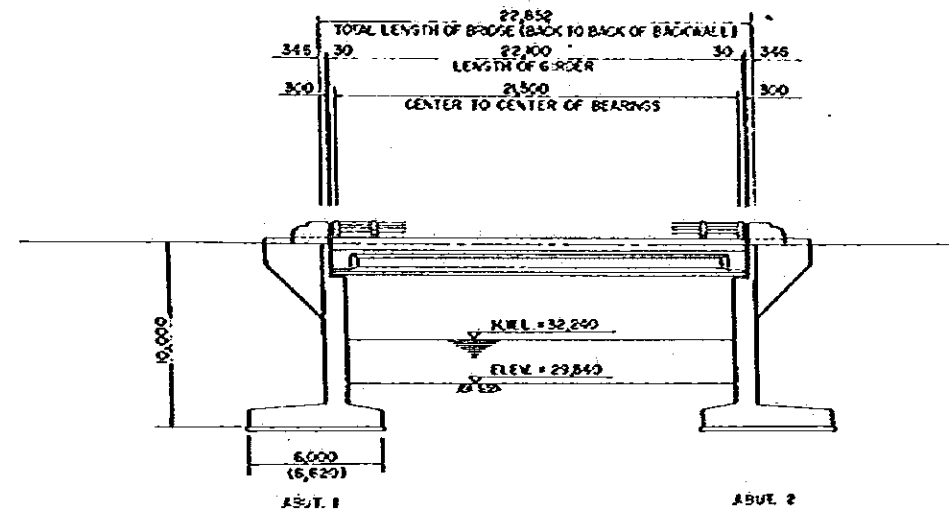

NOTE:  
 ( ) INDICATES SKEW LENGTH

**CROSS SECTION**  
SCALE 1:200

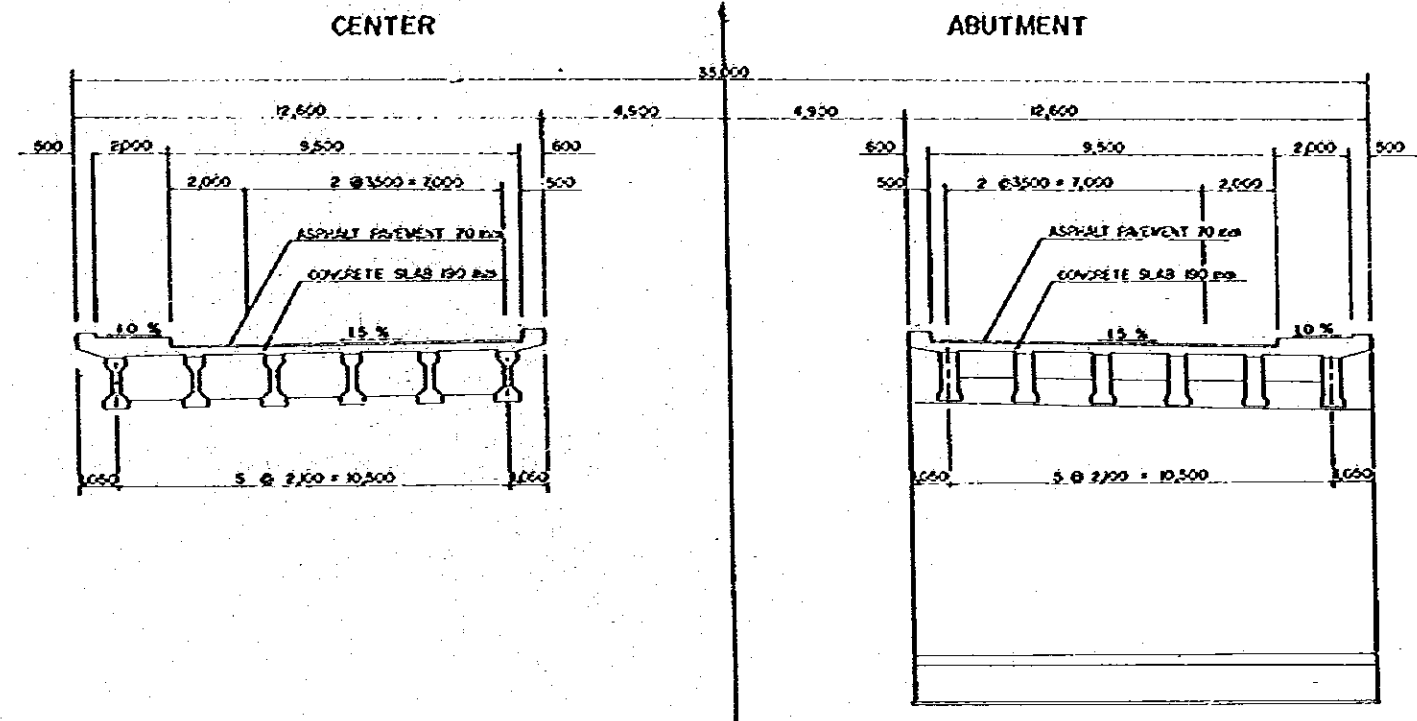

**PLAN**  
SCALE 1:400

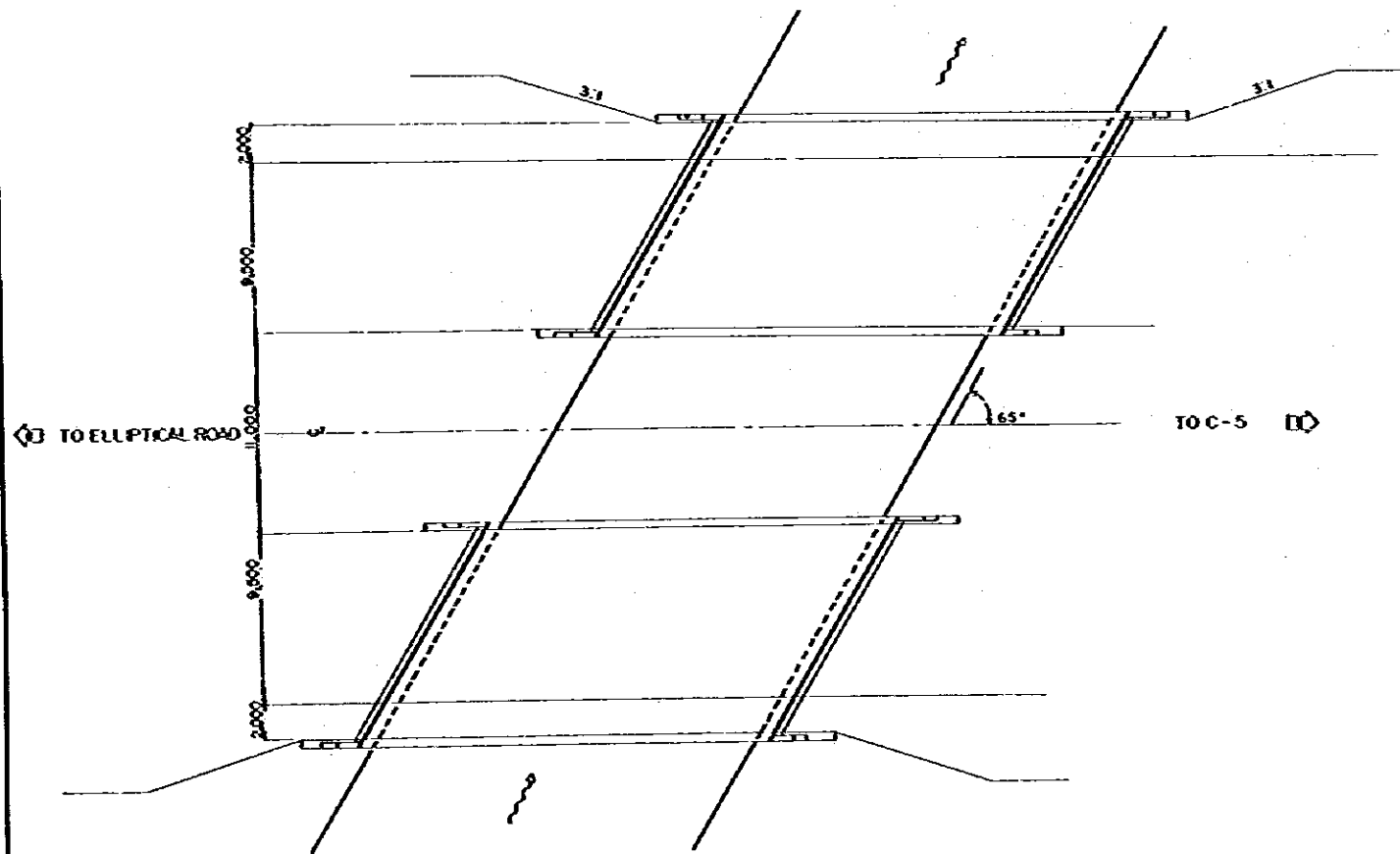

**LOCATION MAP**  
SCALE 1:50,000

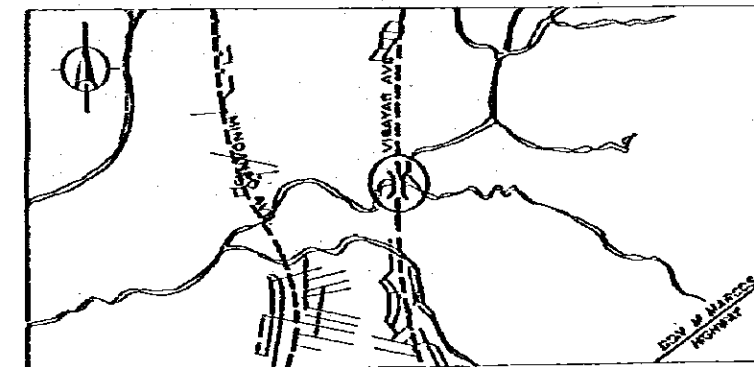



# VISAYAS AVENUE BR-3

THE METRO MANILA OUTER MAJOR ROADS PROJECT (NORTHERN PACKAGE)  
 SCALE: E 200, 1:400  
**VISAYAS AVENUE BR-3**  
 PLAN AND ELEVATION  
 DRAWING NO. 64/66

**ELEVATION**  
SCALE 1:400

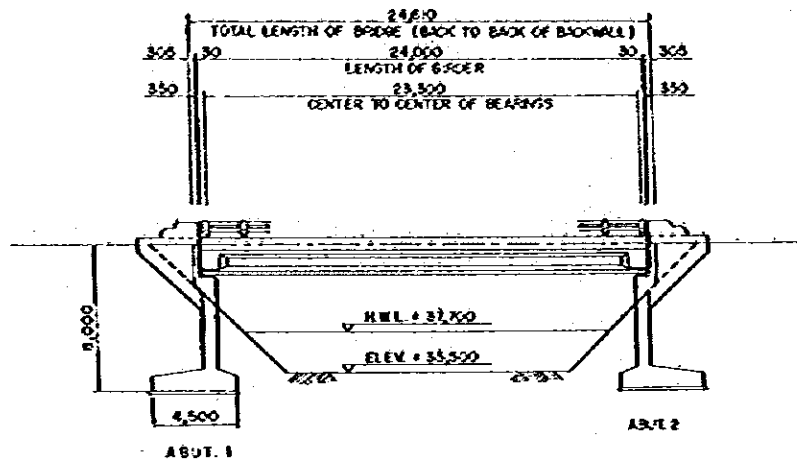

NOTE:  
( ) INDICATES DIM. LENGTH

**CROSS SECTION**  
SCALE 1:200

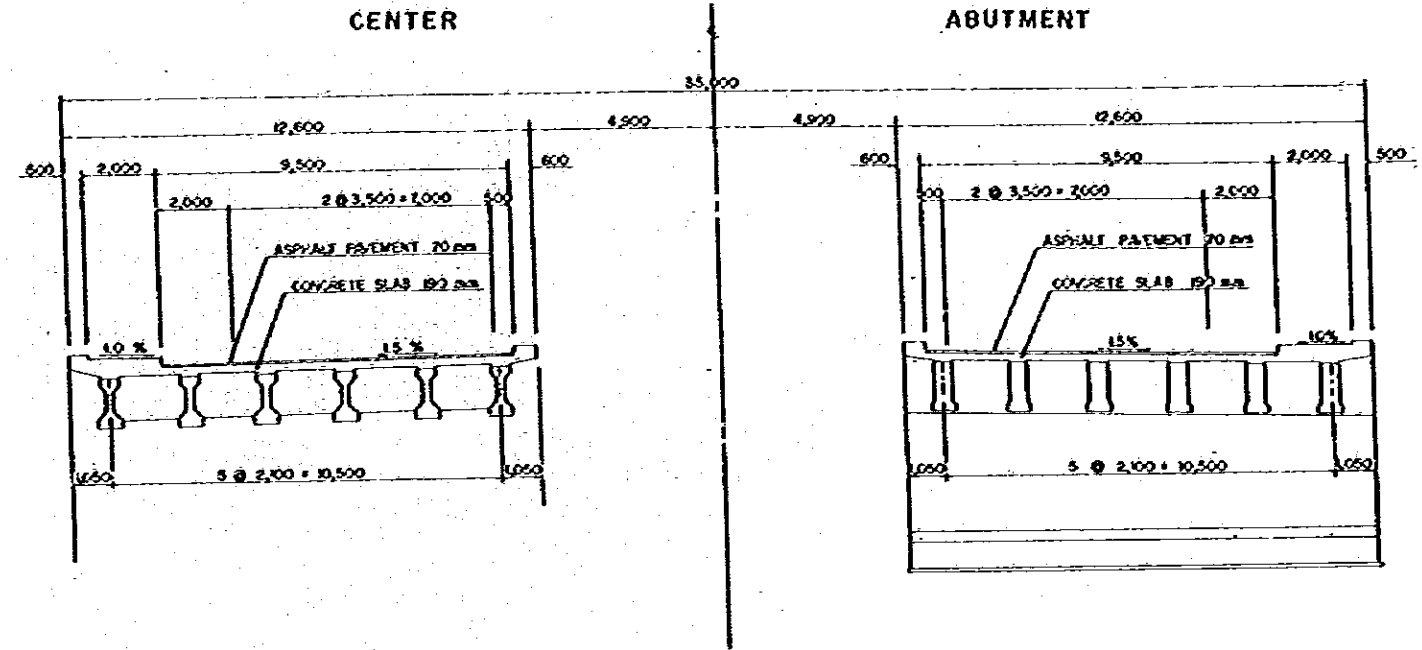

**P L A N**  
SCALE 1:500

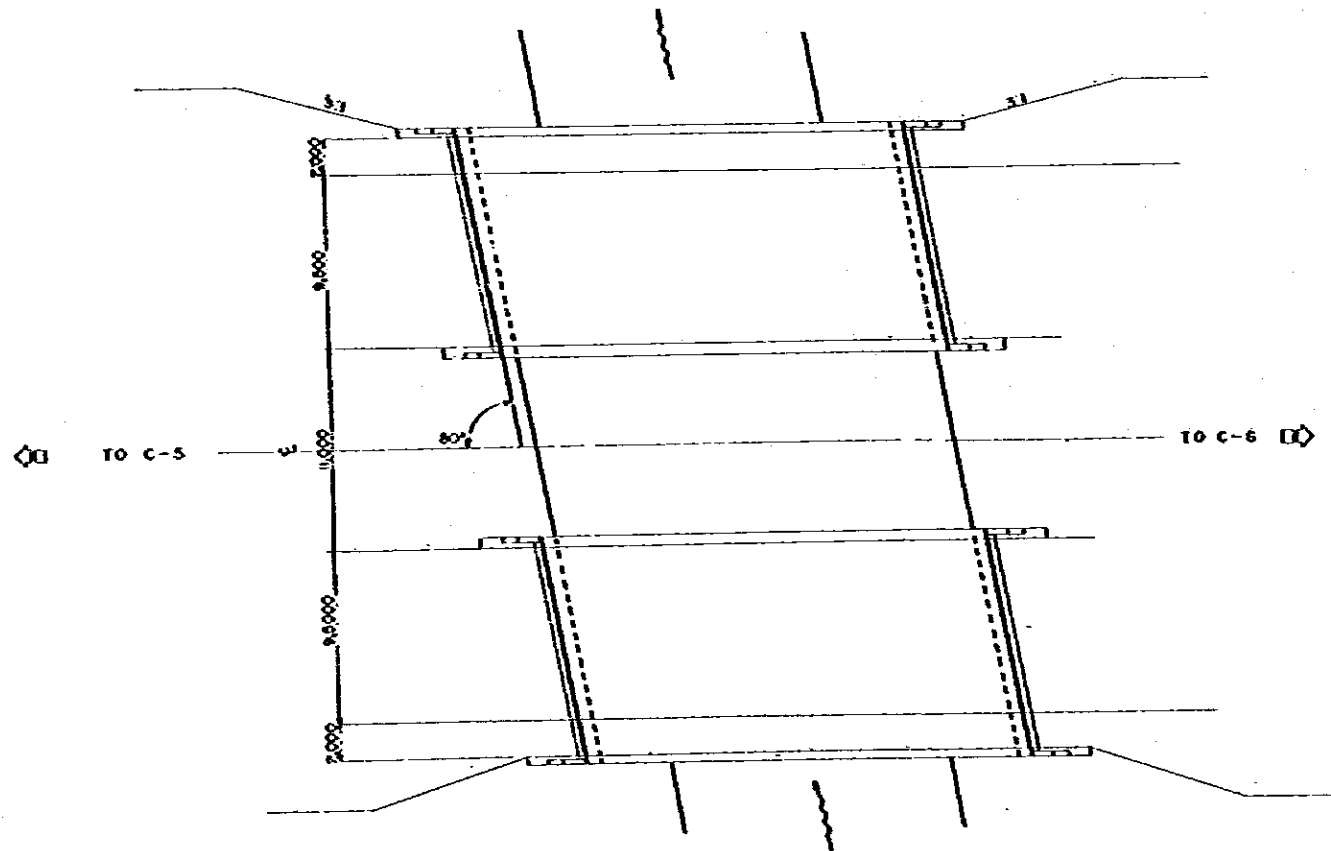

**LOCATION MAP**  
SCALE 1:50,000

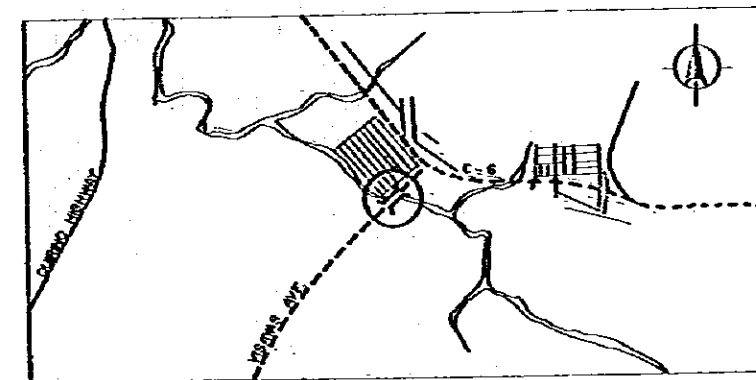

PEDESTRIAN BRIDGE

ELEVATION  
SCALE 1200

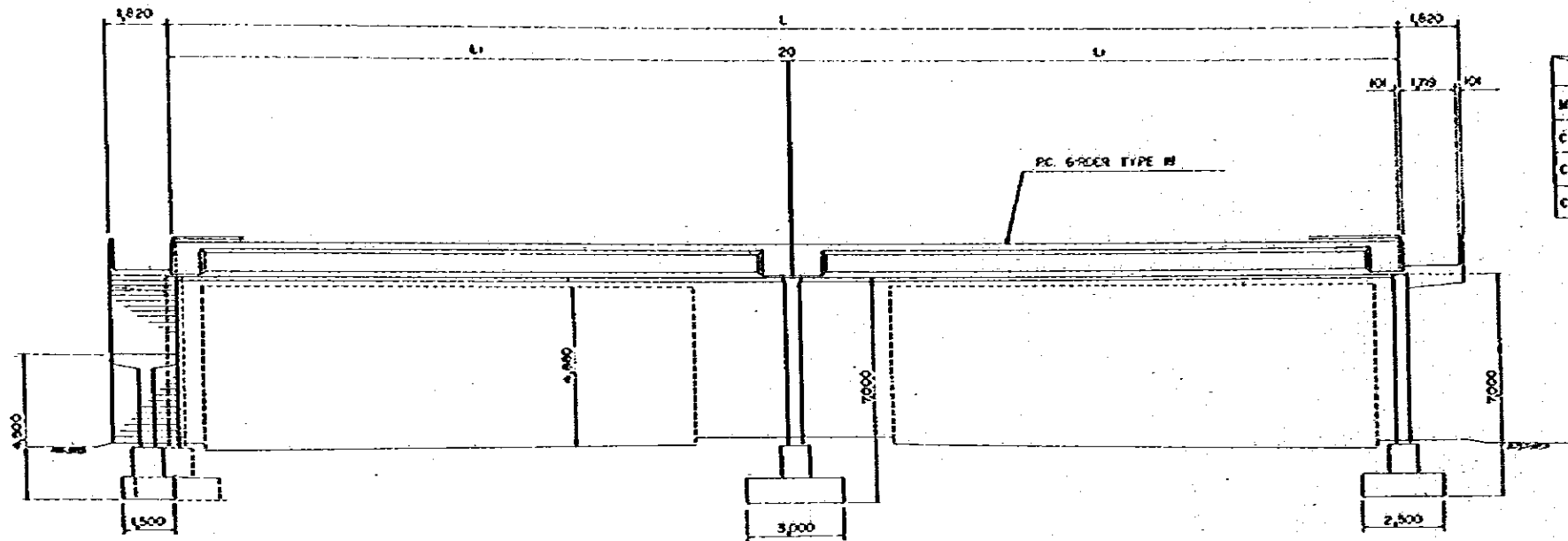

LENGTH OF GIRDER

	L <sub>1</sub>	L <sub>2</sub>
M.N.D.R.	25,850	51,720
C-5 KATIPUNAN	17,350	34,720
C-5 REPUBLIC	21,100	42,220
C-6	18,600	37,220

SECTION A  
SCALE 160

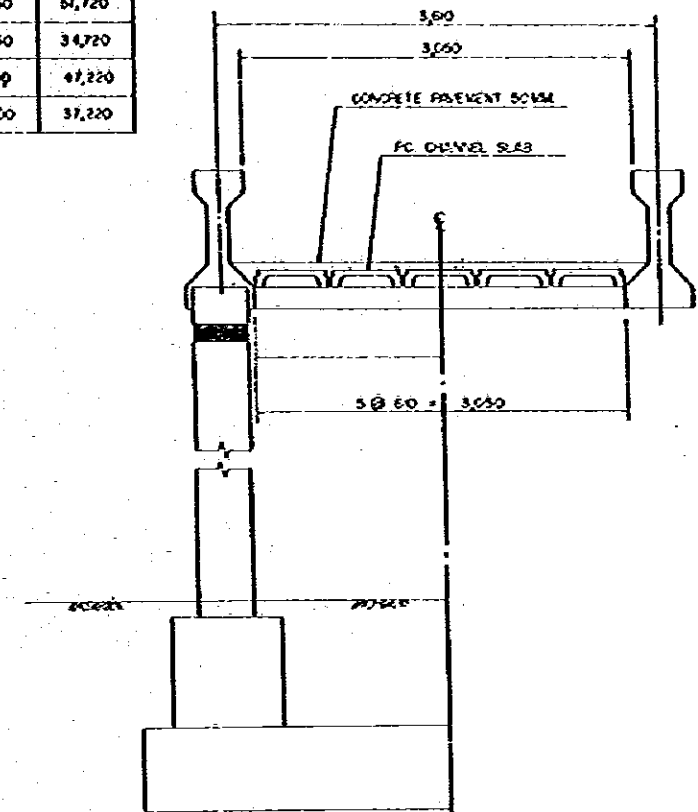

PLAN  
SCALE 1200

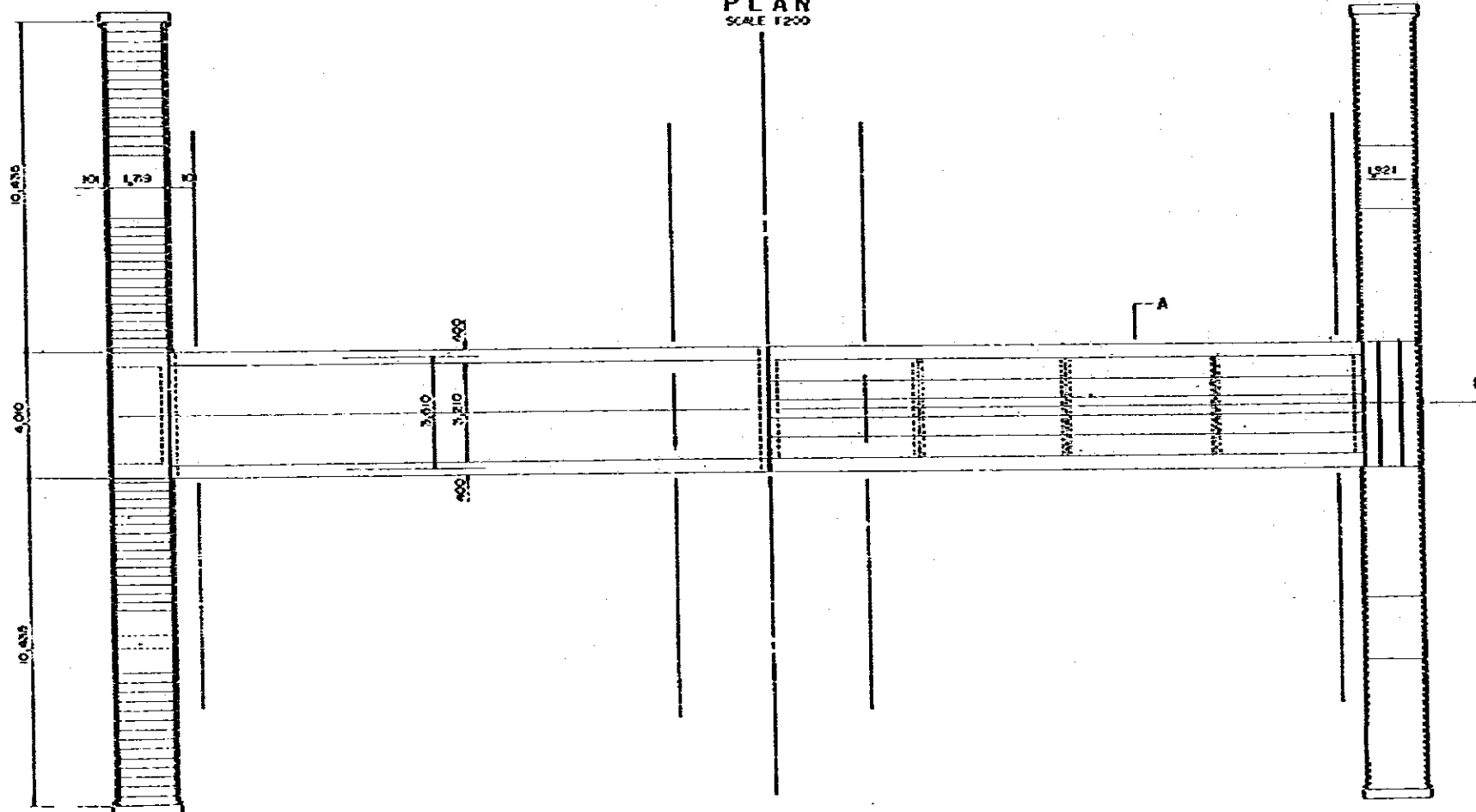

SECTION B  
SCALE 160

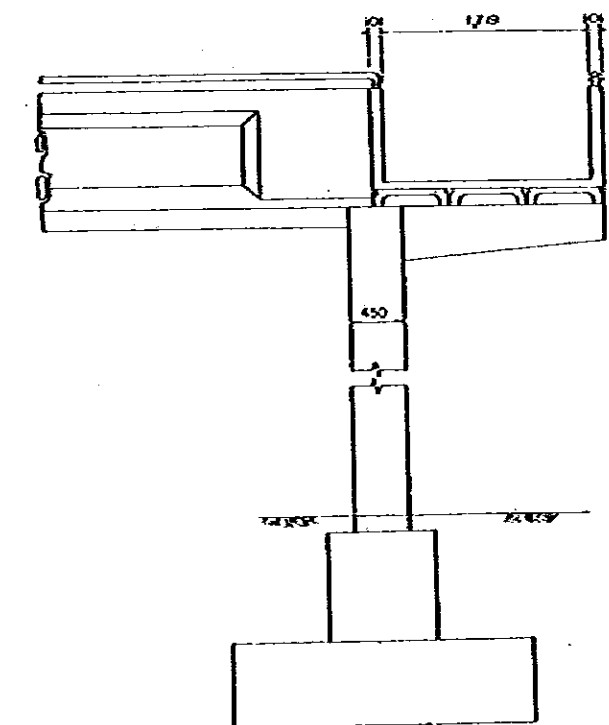

**BOX CULVERT**  
SCALE 1:100

SINGLE

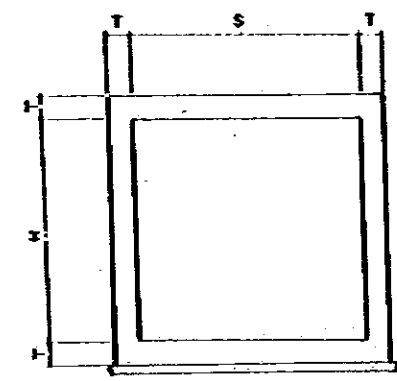

DOUBLE

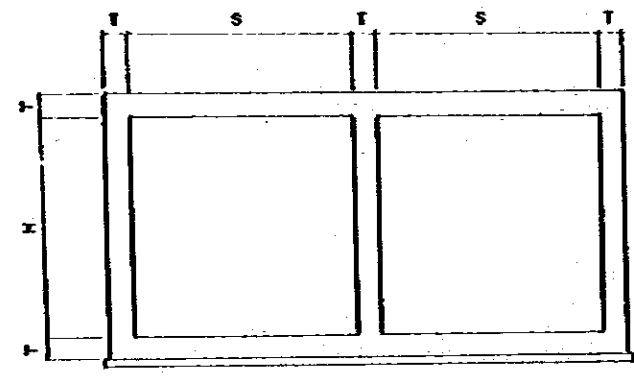

**RETAINING WALLS**  
SCALE 1:100

REVERSED-T

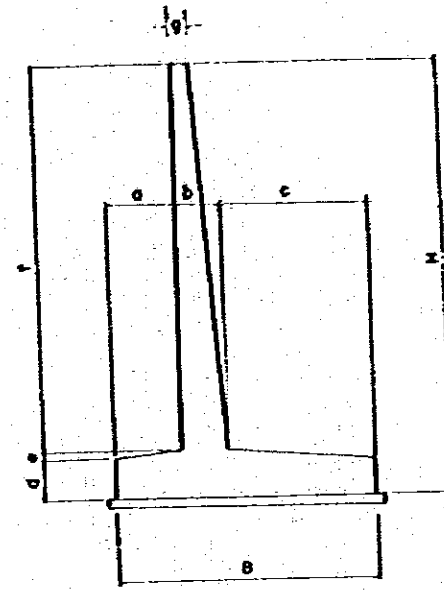

GRAVITY

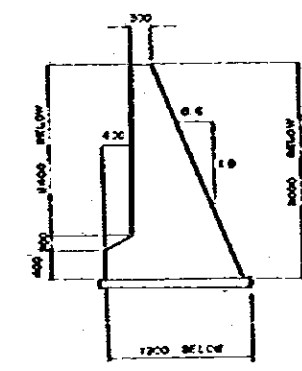

SIZE (mm)			
SPAN S	HEIGHT H	SLAB	
		T(SINGLE)	T(DOUBLE)
3000	3000	280	300
3000	3000	280	300
2400	2780	220	300
2400	2400	220	300
1800	2100	200	250
1800	1800	200	250

SIZE (mm)								
H	a	b	c	d	e	f	g	B
8500	1000	800	3000	700	150	7650	250	4800
6000	900	600	2000	650	100	6350	250	3500
4000	600	400	1500	350	100	3550	250	2500

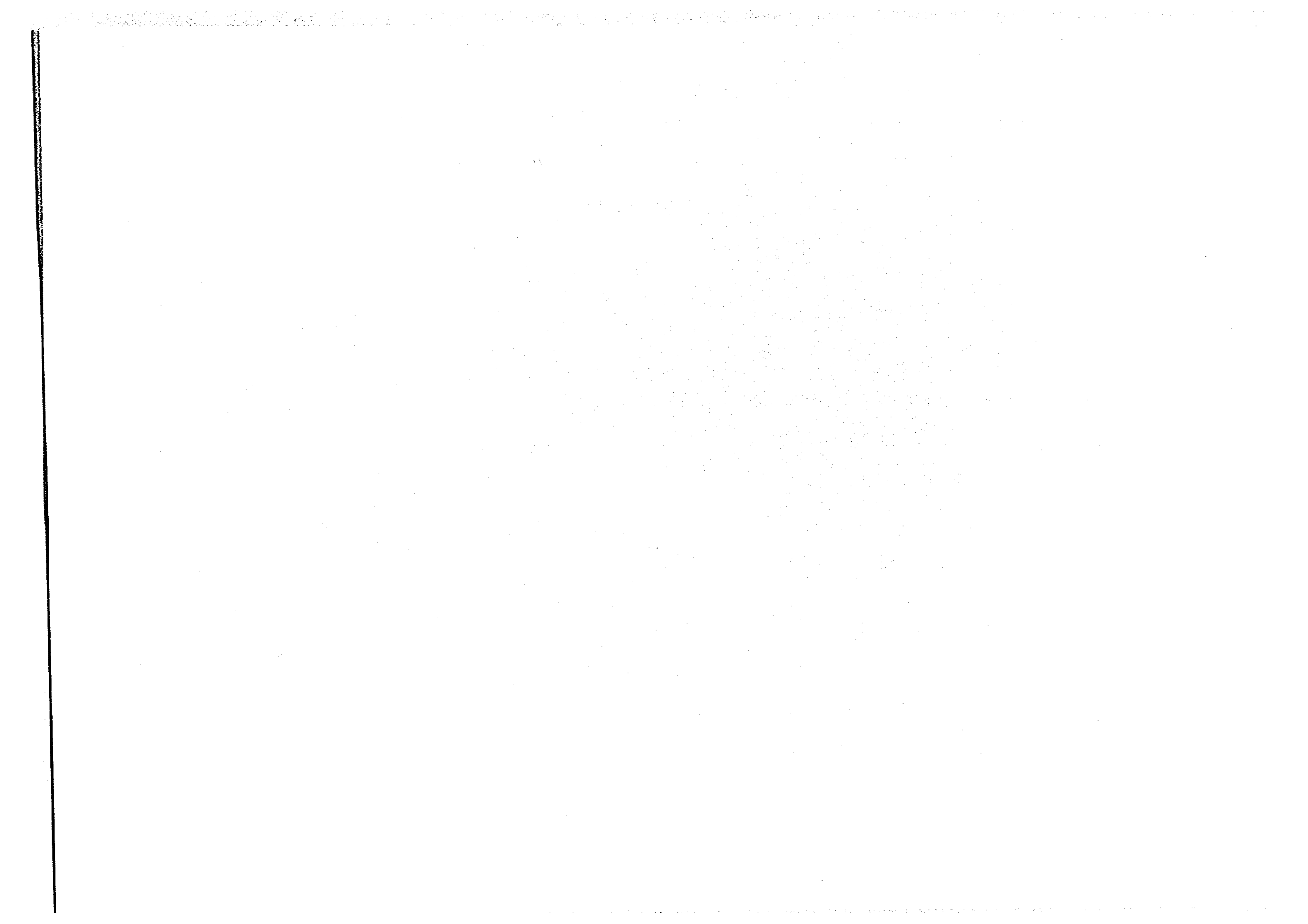

JICA