

**TABLES**

**FOR**

**MAIN REPORT**

**主報告書の付表**



表 3.3-1 バナイ河流域の行政区分現土地利用

Table 3.3-1 Present Land Use by Province, City and Municipality in the Panay River Basin

Prov./City/ <sup>1/</sup> Municipality	Land Use										Total <sup>2/</sup>
	Paddy	Sugarcane	Orchard (coconut)	Pasture/ Grassland	Shrub	Forest	Marshes/ Swamp	Fishpond	Builtup Area/ Village Yard		
Prov. of Capiz	37,140	41,910	7,590	6,040	77,860	11,880	1,850	10,560	1,540	195,170 (89)	
Roxas City	2,030	970	490	160	1,330	150	450	2,300	710	8,590 (4)	
Cuartero	2,640	2,520	300	650	3,640	190	-	-	40	9,980 (5)	
Dao	3,900	1,580	620	-	2,230	410	10	-	80	8,830 (4)	
Dumalag	2,770	2,910	430	260	3,660	1,690	-	-	80	11,800 (5)	
Dumarao	3,850	6,280	510	1,440	9,210	400	-	-	50	21,740 (10)	
Ivisan	-	40	-	-	60	10	-	-	-	110 (-)	
Jamindan	1,780	3,940	540	540	16,090	1,690	-	-	30	24,610 (11)	
Maayon	2,450	7,310	320	1,040	6,350	-	-	-	30	17,500 (8)	
Mambusao	3,690	1,500	1,440	160	3,700	730	10	-	130	11,360 (5)	
Panay	3,660	100	130	-	110	10	1,210	6,620	190	12,030 (6)	
Panitan	2,710	2,660	770	180	710	100	-	-	60	7,190 (3)	
Pilar	-	-	-	-	-	-	-	-	-	- (-)	
Pontevedra	760	1,820	230	70	280	-	110	1,640	50	4,960 (2)	
Pres. Roxas	-	-	-	-	-	-	-	-	-	- (-)	
Sapian	50	170	210	210	710	200	-	-	-	1,550 (1)	
Sigma	3,410	1,840	1,370	230	2,850	290	60	-	40	10,090 (5)	
Tapaz	3,440	8,270	230	1,100	25,730	6,010	-	-	50	44,830 (21)	
Prov. of Iloilo	3,820	6,620	150	2,370	10,070	-	-	-	-	23,030 (11)	
Total	40,960 (19)	48,530 (21)	7,740 (4)	8,410 (4)	86,730 (40)	11,880 (40)	1,850 (5)	10,560 (1)	1,540 (5)	218,200 (100)	

Notes: <sup>1/</sup>: Boundaries of Province/City/Municipality are in accordance with an administrative map prepared by the Ministry of Human Settlement.

<sup>2/</sup>: These areas are decided by the planimetric method based on the administrative map and land use map.

Remarks: Figures in parenthesis are proportions in percentage to the total.

表 3.3-2 洪水氾濫域土地利用及び家屋数

Table 3.3-2 Land Use and Buildings in Flood Vulnerable Area

Sub-area	Land Use (ha)				Buildings (nos.)	
	Paddy	Sugar-cane	Fishpond	Others	Residential	Non-residential
<b>Panay River</b>						
P1	4,388	337	1,136	4,801	6,807	430
P2	750	150	0	188	1,083	93
P3	658	267	0	292	702	3
P4	56	31	0	27	32	0
P5	1,782	433	0	630	1,315	4
P6	77	40	0	50	617	94
P7	436	175	0	273	107	17
P8	1,168	331	0	354	998	132
P9	638	401	0	314	882	186
P10	986	454	1	400	961	86
Sub-total	(10,939)	(2,619)	(1,137)	(7,329)	(13,504)	(1,045)
<b>Maayon River</b>						
Y1	28	12	0	14	21	0
Y2	580	256	0	249	643	67
Y3	118	127	0	84	120	2
Y4	996	23	0	137	449	0
Sub-total	(1,722)	(418)	(0)	(484)	(1,233)	(69)
<b>Mambusao River</b>						
M1	127	14	0	31	128	23
M2	710	95	0	200	786	91
M3	640	55	0	344	753	110
M4	274	24	0	148	323	47
M5	700	113	0	204	419	13
M6	291	171	0	85	603	82
M7	2,432	123	0	588	1,733	31
Sub-totsl	(5,174)	(595)	(0)	(1,600)	(4,745)	(397)
<b>Badbaran River</b>						
B1	103	29	0	56	136	0
B2	796	104	0	285	600	174
Sub-total	(899)	(133)	(0)	(341)	(736)	(174)
<b>Total</b>	<b>(18,734)</b>	<b>(3,765)</b>	<b>(1,137)</b>	<b>(9,754)</b>	<b>(20,218)</b>	<b>(1,685)</b>

Note: The above figures are estimated based on information appeared on 1 : 10,000 map.

表 3.4-1 行政区分别人口预测

Table 3.4-1 Population Projection by City and Municipality (Panay River Basin)

City and Municipality	1985	1990	1995	2000	2005	2010	2015	2020
Roxas City	92,398	104,049	113,269	123,239	131,027	137,602	143,576	149,669
Quartero	20,250	21,981	23,134	24,407	25,949	27,252	28,435	29,641
Dao	26,937	30,037	32,404	34,967	37,176	39,042	40,737	42,466
Dumalag	24,936	27,742	29,667	32,167	34,200	35,916	37,475	39,066
Dumarao <sup>1/</sup>	33,439	26,966	39,657	42,527	45,214	47,483	49,544	51,647
Ivisan <sup>1/</sup>	19,770	22,213	24,132	26,205	27,861	29,259	30,530	31,825
Jamindan <sup>1/</sup>	28,387	31,146	33,105	35,242	37,469	39,349	41,058	42,800
Maayon	29,076	32,546	35,234	38,141	40,552	42,586	44,435	46,321
Mambusao	36,100	40,208	43,332	46,714	49,666	52,158	54,422	56,732
Panay <sup>1/</sup>	35,811	40,107	43,442	47,050	50,023	52,533	54,814	57,140
Panitan	30,226	32,813	34,537	36,440	38,742	40,686	42,453	44,254
Pontevedra <sup>1/</sup>	34,403	38,434	41,535	44,890	47,727	50,122	52,298	54,517
Sapian	20,791	22,854	24,332	25,942	27,581	28,965	30,223	31,506
Sigma	22,254	24,495	26,111	27,868	29,629	31,116	32,467	33,845
Tapaz <sup>1/</sup>	40,200	45,499	49,760	54,369	57,805	60,705	63,341	66,029
Lenery <sup>1/ 2/</sup>	18,496	20,912	24,733	26,268	27,928	29,329	30,602	31,901
Bingawan <sup>1/ 2/</sup>	10,239	10,954	12,315	12,488	13,277	13,943	14,549	15,166
Total - Panay River Basin	523,713	572,956	630,899	678,924	721,826	758,046	790,959	824,525
Capiz Province	550,674	604,263	656,884	706,400	751,038	758,725	822,967	857,892
Region VI	5,092,413	5,672,211	6,249,677	6,799,926	7,301,346	7,728,445	8,119,370	8,520,815
Philippines	54,668,332	61,460,180	68,424,077	75,223,851	81,590,921	87,206,451	92,431,710	97,613,831

Source : o Perspective for Population and Development Planning : Revised Population Projections for the Philippines and its Origin, 1980 - 2030, (MEDIUM - ASSUMPTION), NCSO

o Population Projections by Province, City and Municipality : 1980 - 2000 Region VI - Western Visayas, NCSO.

Notes : 1/; Population covers the whole municipality, though some parts of the municipality are not included by the Panay River Basin.  
2/; Municipality of Iloilo.

表 3.4-2 国内地域別総生産高予測

Table 3.4-2 Projected Gross Regional Domestic Product  
(1972 Constant Price)

Year	The Philippines			Region VI			The Province of Capiz		
	GDP		Growth rate (%)	GRDP <sup>1/</sup>		Growth rate (%)	GRDP <sup>2/</sup>		Growth rate (%)
	Amount (P x 106)			Amount (P x 106)	Per Capita GRDP (P)		Amount (P x 106)	Per Capita GRDP (P)	
1982	99,097 <sup>3/</sup>	-	8,334 <sup>3/</sup>	1,730(R) <sup>3/</sup>	244	917	1,766	249	
1987	104,362 <sup>4/</sup>	1.0	9,025 <sup>4/</sup>	1,696	239	993	1,736	245	
1992	125,287	3.7	10,126	1,717	242	1,114	1,783	251	
1997	171,654	6.5	13,490	2,087	294	1,484	2,194	309	
2000	207,349	6.5	16,081	2,365	333	1,769	2,504	353	
2010	389,223	6.5	29,279	3,788	534	3,221	4,083	575	
2020	730,624	6.5	54,053	6,344	894	5,946	6,931	976	

Notes: <sup>1/</sup>:  $Y = 0.07256 X + 1099.97$  where, Y : GRDP and X : GDP

<sup>2/</sup>: GRDP in Capiz is assumed to occupy approximately 11% of GRDP of Region VI

<sup>3/</sup>: Real Figure

<sup>4/</sup>: Preliminary Projection by NEDA

<sup>5/</sup>: Foreign exchange rate US\$1 = P7.10

表 3.5-1 洪水氾濫域別面積及び浸水家屋数

Table 3.5-1 Estimated Area and Number of Buildings Susceptible to Flood Inundation

Item	Flood Magnitude (Recurrence Probability)				
	2-year	5-year	10-year	25-year	100-year
<b>Inundation Area (km<sup>2</sup>)/<sup>1</sup></b>					
Paddy	85	114	140	160	189
Sugarcane	17	24	29	32	39
Fishpond	2	10	10	10	11
Others	59	65	74	82	99
<b>Total</b>	<b>163</b>	<b>213</b>	<b>253</b>	<b>286</b>	<b>338</b>
<b>Buildings (no., 1000)/<sup>1</sup></b>					
Residential	7.1	10.4	13.7	16.2	20.2
Non-residential	0.5	0.9	1.2	1.3	1.7
<b>Total</b>	<b>7.7</b>	<b>11.3</b>	<b>14.9</b>	<b>17.5</b>	<b>21.9</b>
<b>Population affected/<sup>2</sup> (1000)</b>					
	42.1	62.0	79.6	94.0	121.3

Notes: /1 Based on information appeared on 1 : 10,000 map.

/2 No. of residential buildings x 6 persons/family.

表 3.5-2 1984年開発現況下における確率年毎の洪水被害算定額

Table 3.5-2 Flood Damage by Return Period on Economic Condition in 1984

Categories	(Unit: 1,000 Pesos at 1984 price constant)							
	1	1.1	2	5	10	25	50	100
1. Crop Damage								
Irrigated Paddy	0	2,460	5,585	9,473	13,457	16,905	19,706	21,798
Rainfed Paddy	0	2,602	5,446	8,855	11,525	14,161	16,213	17,787
Vegetables	0	369	805	1,337	1,823	2,267	2,622	2,889
Sugarcane	0	85	102	184	301	467	616	731
Sub-total	0	5,516	11,938	19,849	27,106	33,800	39,157	43,205
2. Live Stock	0	358	775	1,290	1,761	2,197	2,545	2,808
3. Building Damage								
Residential Buildings	0	5,001	10,809	20,665	37,181	65,189	88,674	109,874
Household Effects	0	1,862	4,424	8,618	14,872	23,980	31,157	37,559
Other Buildings	0	4,682	17,464	36,473	68,592	100,938	124,088	147,559
Commercial Stock	0	506	1,892	3,915	7,564	11,405	14,005	16,707
Sub-total	0	12,052	34,590	69,673	128,211	201,514	257,926	311,701
4. Infrastructure Damage	0	4,218	12,106	24,385	44,873	70,529	90,274	109,095
5. Fishpond Damage	0	0	1,622	6,531	12,574	23,980	33,980	46,337
6. Indirect Damage	0	3,321	9,154	18,259	32,179	49,803	63,582	76,972
<b>Total Damage</b>	<b>0</b>	<b>25,467</b>	<b>70,187</b>	<b>139,989</b>	<b>246,706</b>	<b>381,825</b>	<b>487,464</b>	<b>590,119</b>

Note: /1 Average annual flood damage in 1984 is #104,521 x 10<sup>3</sup>.



表 3.5-3 2009年開発現況下における確率年毎の洪水被害算定額

Table 3.5-3 Flood Damage by Return Period on Economic Condition in 2009

Categories	(Unit: 1,000 Pesos at 1984 price constant)									
	1	1.1	2	5	10	25	50	100		
I. Crop Damage										
Irrigated Paddy	0	4,560	10,354	17,562	24,949	31,341	36,534	40,413		
Rainfed Paddy	0	4,636	9,704	15,779	20,537	25,234	28,891	31,696		
Vegetables	0	504	1,099	1,826	2,489	3,095	3,579	3,944		
Sugarcane	0	85	102	184	301	467	616	731		
Sub-total	0	9,787	21,260	35,352	48,277	60,139	69,621	76,785		
2. Live Stock	0	636	1,381	2,297	3,138	3,909	4,525	4,991		
3. Building Damage										
Residential Buildings	0	17,015	36,773	70,302	126,490	221,775	301,672	373,793		
Household Effects	0	6,334	15,050	29,320	50,596	81,580	105,997	127,779		
Other Buildings	0	15,928	59,414	124,083	233,352	343,392	422,148	501,996		
Commercial Stock	0	1,722	6,436	13,320	25,734	38,802	47,646	56,837		
Sub-total	0	41,000	117,675	237,027	436,173	685,550	877,464	1,060,406		
4. Infrastructure Damage	0	14,350	41,186	82,959	152,660	239,942	307,112	371,142		
5. Fishpond Damage	0	0	1,793	7,223	13,906	26,521	37,581	51,248		
6. Indirect Damage	0	9,866	27,494	54,729	98,123	152,409	194,445	234,686		
<b>Total Damage<sup>/1</sup></b>	<b>0</b>	<b>75,640</b>	<b>210,792</b>	<b>419,590</b>	<b>752,280</b>	<b>1,168,473</b>	<b>1,490,751</b>	<b>1,799,260</b>		

Note: /1 Average annual flood damage in 2009 is ₱315,842 x 10<sup>3</sup>.

表 3.5-4 2029年開発現況下における確率年毎の洪水被害算定額

Table 3.5-4 Flood Damage by Return Period on Economic Condition in 2029

(Unit: 1,000 Pesos at 1984 price constant)

Categories	Return Period (Year)							
	1	1.1	2	5	10	25	50	100
<b>1. Crop Damage</b>								
Irrigated Paddy	0	5,503	12,493	21,191	30,103	37,816	44,082	48,762
Rainfed Paddy	0	5,862	12,269	19,950	25,965	31,904	36,527	40,074
Vegetables	0	614	1,339	2,225	3,032	3,771	4,360	4,805
Sugarcane	0	85	102	184	301	467	616	731
Sub-total	0	12,064	26,204	43,550	59,402	73,959	85,586	94,372
<b>2. Live Stock</b>								
	0	784	1,703	2,830	3,861	4,807	5,563	6,134
<b>3. Building Damage</b>								
Residential Buildings	0	58,888	127,269	243,309	437,771	767,544	1,044,058	1,293,663
Household Effects	0	21,923	52,088	101,474	175,108	282,342	366,847	442,231
Other Buildings	0	55,128	205,626	429,442	807,612	1,188,448	1,461,014	1,737,362
Commercial Stock	0	5,959	22,277	46,102	89,063	134,290	164,899	196,700
Sub-total	0	141,900	407,262	820,329	1,509,556	2,372,625	3,036,820	3,669,967
<b>4. Infrastructure Damage</b>								
	0	49,665	142,541	287,115	528,344	830,419	1,062,887	1,284,488
<b>5. Fishpond Damage</b>								
	0	0	1,943	7,824	15,063	28,728	40,708	55,511
<b>6. Indirect Damage</b>								
	0	30,662	86,948	174,247	317,434	496,580	634,734	766,571
<b>Total Damage</b>	0	235,076	666,604	1,335,898	2,433,663	3,807,120	4,866,300	5,877,046

Note: /1 Average annual flood damage in 2029 is ₱1,011,647 x 10<sup>3</sup>.

表 3.7-1 キャピツ県の水道状況 (レベルⅢ)

Table 3.7-1 Functioning Waterworks (Level III) in the Province of Capiz

1. Name of Municipality	Roxas City	Dumarao	Pilar	Dumalag	Ivisan	Sigma
2. Operating Organization	Roxas City Water District	Dumarao Water District	Pilar Water District	Municipality of Dumalag	Municipality of Ivisan	Municipality of Sigma
3. Concerned National Agency	LWUA	LWUA	LWUA	MWSS	MWSS	MPWH
4. Number of Connections	1,377 <sup>1/2</sup> (Residential)	244	200	254	99	84
5. Type	Pumping	Gravity	Gravity	Gravity	Gravity	Gravity
6. Source	River	Spring	Spring	Spring	Spring	River
7. Capacity (lir./sec)	92.6	3.8	6.0	2.3	5.2	3.0
8. Flat Rate (P/month)	-	P25.60	-	P10.00	P10.00	-
9. Meter Charge	(For Residential)					
a. Minimum Charge (P/month)	P35.00 <sup>2/</sup>	P12.80	P15.00	P 8.90	-	P12.00
(Maximum Vol.)	10 m <sup>3</sup>	10 m <sup>3</sup>	20 m <sup>3</sup>	10 m <sup>3</sup>	-	5 m <sup>3</sup>
b. Additional Charge (P/m <sup>3</sup> )		P0.60 (>11 m <sup>3</sup> )	P1.25 (>21 m <sup>3</sup> )	P0.40 (>11 m <sup>3</sup> )	-	P2.40 (>6 m <sup>3</sup> )
		P2.10 (>11 m <sup>3</sup> )	P0.80 (>21 m <sup>3</sup> )			
		P2.70 (>21 m <sup>3</sup> )	P1.10 (>37 m <sup>3</sup> )			
10. Remarks		Meter deposit P350	Meter deposit P50		Flat rate only	

Notes: 1/: June 1984

2/: Oct. 1984

as of the end of 1984

表 3.8-1 パナイ配電網内の電力供給及び消費記録

Table 3.8-1 Historical Data on Power Supply and Consumption in Panay Grid

Cooperative	N P C		Cooperative			Annual Load Factor %	S o l d					Plant Service MWh	Losses MWh	
	Generated MWh	Sold MWh	Own Generation MWh	Energy Purchased from MWh	Peak Load kW		Residential MWh	Commercial MWh	Industrial MWh	Others MWh	Sold Amount MWh			
1978														
CAPELCO			113,479	113,479	n.a.		30,521	17,521	29,506	6,136	84,134	5,957	23,388	
AKELCO			20,041	15,372	5,800		5,442	2,506	815	1,668	10,431	1,700	3,241	
PECO			84,722	4,669	1,970		2,137	901	73	466	3,377	76	1,016	
ILECO I			8,016	84,722	16,100		20,013	13,846	26,600	3,250	63,714	3,913	17,095	
ANTECO			700	6,729	2,800		2,100	463	2,002	500	5,065	141	1,523	
ILECO II			122,929	1,287	590		510	110	16	121	757	30	500	
1979														
CAPELCO	2,747	2,747	122,929	125,670	31,280	45.9	35,324	19,871	32,647	6,982	94,824	5,551	25,295	
AKELCO			28,029	17,820	6,200		5,800	2,510	1,065	1,800	11,175	1,500	5,145	
PECO			83,489	6,209	2,300		2,749	1,100	287	609	4,745	64	1,400	
ILECO I			10,528	86,230	16,400		21,100	14,800	27,622	3,558	67,080	3,750	15,400	
ANTECO			4,883	8,927	3,480		3,072	521	2,900	600	7,093	134	1,700	
ILECO II			82,690	1,601	700		603	140	23	165	931	20	650	
1980														
CAPELCO	4,536	73,930	65,861	139,791	34,110	46.8	40,102	21,752	35,497	7,831	105,182	5,070	29,539	
AKELCO			20,567	20,400	6,600		6,100	2,556	1,571	2,000	12,227	1,280	6,893	
PECO			30,473	6,956	2,850		3,228	1,294	445	650	5,617	62	1,277	
ILECO I			14,107	89,509	16,900		22,360	15,700	28,100	3,900	70,060	3,500	15,949	
ANTECO			714	12,013	4,100		4,097	612	3,900	676	9,285	128	2,600	
ILECO II			112,689	2,094	810		817	190	31	217	1,255	19	820	
1981														
CAPELCO	13,471	102,604	51,965	154,569	36,870	47.9	45,025	23,615	38,336	8,659	115,635	4,648	34,286	
AKELCO			9,539	23,010	7,000		6,500	2,645	2,395	2,200	13,740	1,070	8,200	
PECO			36,323	9,517	3,350		4,035	1,627	748	661	7,071	60	2,386	
ILECO I			6,103	92,987	17,450		24,020	16,567	28,500	4,300	73,387	3,300	16,300	
ANTECO			11,166	14,776	4,650		5,012	722	4,800	720	11,254	122	3,400	
ILECO II			11,786	2,493	920		970	254	43	258	1,525	18	950	
1982														
CAPELCO	111,409	97,794	69,046	166,840	39,420	48.3	49,790	25,555	40,450	9,494	125,289	4,226	37,325	
AKELCO			9,699	25,685	7,500		6,921	2,713	2,741	2,406	14,781	860	10,044	
PECO			10,704	10,704	4,000		4,492	1,690	982	736	7,900	58	2,746	
ILECO I			57,756	96,431	17,200		25,531	17,700	28,700	4,600	76,531	3,100	16,800	
ANTECO			1,591	18,453	5,760		6,464	914	5,965	794	14,137	116	4,200	
ILECO II			12,471	3,096	1,000		1,232	338	62	308	1,940	17	1,139	
1983														
CAPELCO	134,360	122,623	58,070	180,693	42,450	48.6	54,552	27,565	42,160	10,367	134,644	8,323	42,226	
AKELCO			6,324	27,100	7,800		7,243	2,828	2,900	2,502	13,473	652	10,975	
PECO			51,746	11,721	4,200		5,083	1,846	1,150	953	9,032	55	2,634	
ILECO I			48,674	100,420	18,500		27,330	18,894	29,000	4,919	80,143	2,919	17,358	
ANTECO			2,252	22,292	6,000		7,549	1,087	6,866	846	16,348	110	4,834	
ILECO II			16,280	3,880	1,150		1,680	432	96	354	2,562	16	1,302	
				16,280	4,800		5,167	2,478	2,148	793	11,086	71	5,123	

Source: NEA Manila and PECO

Note : Some figures are modified by the result of study

表 3.8-2 キャピツ県内の電力供給及び消費記録

Table 3.8-2 Historical Data on Power Supply and Consumption in Capiz Province

Item	1973	1974	1975	1976	1977	1978	1979	1980	1981	1982
1. Power generation by CAPELCO (MWh)	79	1,327	3,040	4,915	6,797	20,041	28,140	20,573	11,930	10,089
2. Power purchased from NPC (MWh)	-	-	-	-	-	-	-	4,969	13,176	15,596
3. Total energy (MWh)	79	1,327	3,040	4,915	6,797	20,041	28,140	25,542	25,106	25,685
4. Station uses (MWh)	18	177	281	491	723	1,258	1,616	1,383	882	1,014
5. Distribution losses (MWh)	53	430	837	1,304	1,261	10,079	16,892	14,159	12,040	12,262
(%)	66	32	27	26	19	50	60	55	48	43
6. Sold (kWh)	9	719	1,922	3,119	4,813	8,703	9,631	10,000	12,184	12,408
1) Residential (MWh)	6	649	1,707	2,205	3,667	5,442	5,824	5,854	7,191	6,936
(nos.)	172	2,289	3,877	5,683	8,499	12,123	15,401	15,829	22,131	23,697
2) Commercial (MWh)	1	66	209	362	404	2,579	2,915	2,556	2,569	2,663
(nos.)	14	175	197	206	284	772	899	883	904	1,017
3) Industrial (MWh)	0	0	0	545	734	674	883	1,571	2,395	2,741
(nos.)	0	0	0	12	14	23	24	22	33	42
4) Street lights (MWh)	2	4	6	8	8	8	9	19	29	27
(nos.)	35	143	307	364	497	573	613	575	594	528
7. Peak load (kW)	-	1,080	1,230	1,672	1,672	5,300	9,300	8,900	7,150	7,500
8. Annual load factor (%)	-	14.02	28.22	33.56	46.40	43.17	34.54	32.76	40.08	39.09
9. Average tariff (P/kWh)	0.43	0.70	0.56	0.54	0.87	1.15	1.07	1.11	1.18	1.43

Source: CAPELCO and PDPP II

Remark: For the data of 1983, refer to Table 3.8-1

表 4.2-1 河川区内及び主要町村別洪水被害ポテンシャル

Table 4.2-1 Flood Damage Potential by River Stretch and Major Town

Item	River Stretch No.	River Length (km)	Flood Area (km <sup>2</sup> )	Annual Average Damage (10 <sup>3</sup> Pesos)			Population in Flood Prone Area (10 <sup>3</sup> Pesos)			Damageability Level	Remarks
				Total	Per km	Per km <sup>2</sup>	Total	Per km	Per km <sup>2</sup>		
1. Whole Basin:		162.5	338.2	104,571	641	309	121.3	0.74	0.36	-	
2. By River Stretch:											
Panay river	P1	13.0	106.6	21,550 (31,784)	1,658 (2,445)	202 (298)	35.4 (60.8)	2.72 (3.14)	0.34 (0.38)	Level-1	(Incl. Pontevedra and Panay)
	P2	4.0	10.9	1,375 (3,652)	344 (913)	126 (335)	4.1 (6.5)	1.03 (1.63)	0.38 (0.60)	Level-2	To be protected as an integral part of P1. (Incl. Panitan)
	P3	9.0	12.2	2,237	249	181	4.2	0.47	0.34	Level-3	Right bank area worthy for protection
	P4	2.2	1.1	130	59	118	0.2	0.09	0.18	Level-3	
	P5	7.0	28.5	5,424	774	190	7.9	1.07	0.28	Level-1	
	P6	1.8	1.5	24 (4,607)	13 (2,539)	16 (3,071)	1.2 (3.7)	0.67 (2.06)	0.80 (2.47)	Level-3	To be protected as an integral part of P5. (Incl. Dao)
	P7	8.8	13.1	952	108	73	0.6	0.07	0.05	Level-3	Protection of left bank area to be considered.
	P8	5.4	18.5	5,576 (16,136)	1,032 (2,388)	801 (872)	5.2 (6.0)	0.96 (1.11)	0.28 (0.32)	Level-1	(Incl. Cuartero)
	P9	8.6	13.5	1,390 (1,791)	161 (208)	103 (133)	3.4 (5.3)	0.40 (0.62)	0.25 (0.39)	Level-2	(Incl. Dumalag)
	P10	16.8	18.4	1,972 (2,027)	117 (121)	107 (110)	4.4 (5.8)	0.26 (0.35)	0.24 (0.32)	Level-3	(Incl. Tapaz)
Maayon river	Y1	1.3	0.5	152	84	304	0.1	0.06	0.20	Level-3	
	Y2	6.4	10.9	2,050 (4,585)	320 (716)	183 (421)	2.6 (3.9)	0.41 (0.61)	0.24 (0.36)	Level-2	(Incl. Maayon)
	Y3	5.0	3.3	465	93	161	0.7	0.14	0.21	Level-3	
	Y4	12.0	11.6	2,526	219	226	2.7	0.23	0.23	Level-2	
Mambusao river	M1	2.2	1.7	626	285	368	0.8	0.36	0.47	Level-2	
	M2	9.0	10.1	1,329 (4,064)	148 (452)	132 (402)	3.2 (6.7)	0.36 (0.52)	0.32 (0.46)	Level-2	(Incl. Sigma)
	M3	10.0	10.4	2,325 (8,634)	283 (863)	272 (830)	2.3 (4.5)	0.23 (0.45)	0.22 (0.43)	Level-2	(Incl. Mambusao)
	M4	3.2	4.5	1,909	315	224	1.0	0.31	0.22	Level-2	
	M5	11.3	10.2	1,509	134	148	2.5	0.22	0.25	Level-3	
	M6	5.2	5.5	1,948 (3,567)	375 (686)	354 (649)	1.8 (3.6)	0.35 (0.69)	0.33 (0.65)	Level-2	To be improved only after M1-M5 are improved. (Incl. Jamindan)
	M7	8.6	31.4	6,217	723	198	10.4	1.21	0.33	Level-1	To be improved only after M1 to M4 are improved.
Sedbaran river	B1	3.4	1.9	240	70	126	0.8	0.24	0.47	Level-3	
	B2	7.8	11.9	1,001 (2,077)	128 (266)	84 (174)	2.1 (3.6)	0.27 (0.46)	0.18 (0.30)	Level-3	(Incl. Dumarao)
3. By Major Town:											
Pontevedra	P1	-	1.30	9,859	-	1,583	3.0	-	2.30	Level-1	
Panay	P1	-	0.51	374	-	733	2.4	-	4.70	Level-3	
Panitan	P3	-	1.00	2,277	-	2,277	2.4	-	2.40	Level-2	
Dao	P6	-	1.17	4,582	-	3,916	2.5	-	2.14	Level-2	
Cuartero	P8	-	0.49	10,560	-	21,551	0.8	-	1.63	Level-1	
Dumalag	P9	-	0.66	400	-	606	1.9	-	2.88	Level-3	
Tapaz	P10	-	0.64	54	-	84	1.4	-	2.19	Level-3	
Maayon	Y2	-	0.23	2,534	-	11,017	1.3	-	5.65	Level-1	
Sigma	M2	-	0.47	2,735	-	5,819	1.5	-	3.19	Level-1	
Mambusao	M3	-	1.03	5,809	-	5,640	3.2	-	3.11	Level-1	
Jamindan	M6	-	0.18	1,619	-	8,994	1.8	-	10.0	Level-1	
Dumarao	B2	-	0.48	1,075	-	2,240	1.5	-	3.13	Level-2	

Notes: <sup>1/</sup> Length along proposed channel improvement.  
<sup>2/</sup> Area and annual flood damage at 100-year flood occurrence.

<sup>3/</sup> Damage potential level:

River Stretch (10 <sup>3</sup> P/km)	Major Town (10 <sup>3</sup> P/km <sup>2</sup> )
500 over	5,000 over
300 - 150	5,000 - 1,000
150 under	1,000 under

( ) Including major town.

Level 1  
 Level 2  
 Level 3

表 4.2-2 河川区内ごとの洪水被害指標

Table 4.2-2 Flood Routing Capacity by Stretch

Location	Stretch No.	Flood <sup>/1</sup> Routing Volume (10 <sup>6</sup> m <sup>3</sup> )	Damage <sup>/2</sup> Potential (10 <sup>3</sup> ₱)	Routing <sup>/3</sup> Capacity Index (₱/ m <sup>3</sup> )	Damage <sup>/4</sup> Potential Level	Proposed Retarding Basin
<u>Panay River:</u>						
1. Upstream of Panitan	P3, P4	60.2	2,366	39	3	**
2. Maayon junction- Mambusao junction	P5	68.6	5,424	79	1	
3. Upstream of Dao	P6, P7	21.0	976	46	3	**
4. Upstream of Cuartero	P8	87.1	5,576	64	1	
5. Upstream of Badbaran junction	P9	28.3	1,390	49	2	*
6. Upstream of Dumalag	P10	44.4	1,972	44	3	**
<u>Maayon River:</u>						
7. Downstream stretches	Y1, Y2, Y4	44.0	4,198	95	2-3	*
<u>Mambusao River:</u>						
8. Upstream of Mambusao town	M4 - M6	24.5	4,166	170	2-3	*
9. Balacuan river	M7	12.1	6,217	513	1	
<u>Badbaran River:</u>						
10. All stretches	B1 - B3	40.2	1,241	31	3	**

Notes: <sup>/1</sup> Routing volume at 100-year flood<sup>/2</sup> Annual average flood damage<sup>/3</sup> Damage potential/Routing volume<sup>/4</sup> See Table

\* Suitable

\*\* Most suitable

表 4.2-3 防御代替案 (構造物による対策)

Table 4.2-3 Protection Area Alternatives - Structural Measures

River Stretch		Damageability Level <sup>/1</sup>	Alternative					
			1	2	3	4	5	6
<b>Panay River</b>								
Stretch	P1	1	o	o	o	o	o	o
"	P2	2	o	o	o	o	o	o
"	P3	3	x	Δ	Δ	Δ	o	o
"	P4	3	x	x	x	x	x	o
"	P5	1	x	o	o	o	o	o
"	P6	3	x	o	o	o	o	o
"	P7	3	x	Δ	Δ	Δ	Δ	o
"	P8	1	x	x	o	o	o	o
"	P9	2	x	x	x	o	o	o
"	P10	3	x	x	x	x	x	o
<b>Maayon River</b>								
Stretch	Y1	3	x	x	x	x	x	o
"	Y2	2	x	x	x	o	o	o
"	Y3	3	x	x	x	x	x	o
"	Y4	2	x	x	x	o	o	o
<b>Mambusao River</b>								
Stretch	M1	2	x	x	o	o	o	o
"	M2	2	x	x	o	o	o	o
"	M3	2	x	x	o	o	o	o
"	M4	2	x	x	x	x	o	o
"	M5	3	x	x	x	x	x	o
"	M6	2	x	x	x	x	o	o
"	M7	1	x	x	x	o	o	o
<b>Badbaran River</b>								
Stretch	B1	3	x	x	x	x	x	o
"	B2	3	x	x	x	x	x	o

Notes: o Area to be protected by structural measures  
 Δ Area partially protected  
 x Area to be left unprotected for use as retarding basin  
 /1 See Table 4.2-1



表 4.2-4 防御地域代替案の評価

Table 4.2-4 Evaluation of Protection Area Alternatives

Item	Protection Area Alternative <sup>/1</sup>					
	1	2	3	4	5	6
Flood Discharge <sup>/2</sup> (m <sup>3</sup> /sec)	2,670	3,120	4,320	4,520	5,400	6,350
Effect of Protection Work:						
- Annual damage reduction (¥ x 10 <sup>6</sup> )	35.4	46.8	76.2	91.4	97.4	104.5
- Population protected (1000)	44.9	59.2	75.2	97.5	107.2	121.3
- Agricultural land protected (km <sup>2</sup> )	47.8	68.3	92.9	137.4	144.8	170.7
Cost of Protection Work <sup>/3</sup> (¥ x 10 <sup>6</sup> )	1,021	2,293	3,917	4,680	5,344	6,987
Comparison Indices:						
- Cost effectiveness <sup>/4</sup>	0.70	0.42	0.39	0.39	0.36	0.30
- % Population protected <sup>/5</sup>	37	49	62	80	88	100
- % Agricultural land protected <sup>/6</sup>	21	30	41	60	64	75
Selected Plan				*		

Notes: /1 See Table 4.2-3 for location of protection areas.

/2 100-year flood at Panitan base station.

/3 Cost of river improvement works

/4 Expressed in terms of benefit cost ration (= Present worth of damage reduction/Present worth of cost).

/5 % of total population in the flood vulnerable area (121,300)

/6 % to total agricultural land in the flood vulnerable area (227.9 km<sup>2</sup>)

表 4.2-5 非施設対策による代替案

Table 4.2-5 Non-structural Measure Alternatives

Measure	Appropriate Applications	Application to Panay River Basin
<p><u>Modify damage susceptibility</u> Flood plain management</p>	<p>Where uses other than agricultural are competing, especially where they involve urban and industrial uses.</p>	<p>This measure is applicable to all areas of the basin, though agricultural land use is prominent.</p>
<p>Structural change</p>	<p>Where building/property damage is remarkable with frequent inundation, especially where the depth of flooding is not large.</p>	<p>This measure is applicable to the Panay river basin, in areas where flooding is less than 1 m deep.</p>
<p>Flood proofing</p>	<p>Where buildings are scattered and frequently flooded, especially where flooding is less than 1 m, 3-hr advanced warning is possible.</p>	<p>Such measures as closure of openings and waterproofing interior would be impractical in view of type of local buildings. This plan was, therefore, not examined in this study.</p>
<p>Subsidised relocation</p>	<p>Essentially, this is a part of measures included in flood plain management. This measure is appropriate in areas where building/property damages are severe with possible risk to human life.</p>	<p>This measure is worthy of evaluation for all areas in the basin.</p>
<p>Disaster relief</p>	<p>Elsewhere.</p>	<p>This measure is presently undertaken. Excessive adoption of this measure tends to remove the incentive to avoid future flood losses, and, therefore, this measure would not be an ultimate measure for the basin. No detailed evaluation was attempted in this study.</p>
<p><u>Modify the loss burden</u></p>	<p>Elsewhere, if approved by the government.</p>	<p>As in the case of disaster relief, this measure provides little incentive to reduce flood losses. Moreover, this is not supported by present legislation. Therefore no further study was attempted.</p>
<p>Tax write-offs</p>	<p>Elsewhere, if insurance system is available.</p>	<p>This type of insurance system is presently not available, and, therefore, not applicable to the basin. Moreover, this measure cannot be studied at a river basin study level, but to be left to a specific nation level study.</p>
<p>Flood insurance</p>	<p>Elsewhere, and especially where flood-to-peak interval is longer than 1 day.</p>	<p>Applicable. This system is prerequisite as a supporting measure to any type of structural methods or other non-structural methods.</p>
<p>Flood forecasting and warning system</p>	<p>Where enough runoff remains in low-water period, even if this program is undertaken.</p>	<p>No detailed study was attempted in view of lack of data. While, forestation in the watershed area is worthy of encouragement not only for flood control purpose but also other development purposes.</p>
<p><u>Modify the flood watershed management</u></p>	<p></p>	<p></p>

Note: \* Specific program as a part of "flood plain management" in a broad meaning.

表 5.2-1 河川改修工事（長期案）の経済評価  
 - 河川区間ごと（ダムなし）

Table 5.2-1 Economic Evaluation of River Improvement Works (LP) - By River Stretch (Without Dams)

River	Stretch No.	Length (km)	Construction Cost (P x 10 <sup>6</sup> )	Present Worth <sup>/1</sup> (P x 10 <sup>6</sup> )			Remarks
				Cost (C)	Benefit (B)	Net Benefit (B - C)	
Panay	P1	13.0	1,580	906	136	-770	
	P2	4.0	204	117	45	-72	
	P3	9.0	461	269	11	-258	
	P4	2.2	-	-	-	-	
	P5	7.0	310	177	63	-114	
	P6	1.8	64	36	66	30	
	P7	8.8	285	166	6	-160	
	P8	5.4	191	109	220	111	
	P9	8.6	139	79	22	-57	
	P10	16.8	-	-	-	-	
Maayon	Y1	1.8	-	-	-	-	
	U2	6.4	202	116	64	-52	
	Y3	5.0	-	-	-	-	
	Y4	12.0	192	109	31	-78	
Mambusao	M1	2.2	107	62	7	-55	
	M2	9.0	390	226	54	-172	
	M3	10.0	434	250	120	-130	
	M4	3.2	-	-	-	-	
	M5	11.3	-	-	-	-	
	M6	5.2	-	-	-	-	
	M7	8.6	120	69	74	5	
Badbaran	B1	3.4	-	-	-	-	
	B2	9.8	-	-	-	-	
Total		162.5	4,680	2,691	919	-1,772	EIRR=2.8%

Notes: /1 Discount rate: 3% p.a.  
 \* Partial improvement of low water channel  
 - No improvement

表 5.2-2 放水路計画と対応する河川改修計画

Table 5.2-2 Floodway Plans and Corresponding River Improvement Plans

Location of Floodway	Floodway Plan		River Improvement Only	
	Works Involved	Cost/ <sup>1</sup> (P x 10 <sup>6</sup> )	Works Involved	Cost (P x 10 <sup>6</sup> )
FW-1: Mambusao - Balacuan Floodway	- Construction of floodway - Improvement of stretches M1 to M4 for reduced flood discharges	1,113	- Improvement of river stretches M1 to M4	787
FW-2: Mambusao - Sapian Floodway	- Construction of floodway - Improvement of stretches P1 to P6 and M1 to M4 for reduced flood discharges	7,026	- Improvement of stretches P1 to P6 and M1 to M4	3,629
FW-3: Panitan Floodway	- Construction of floodway - Improvement of stretch P2 for reduced flood discharge	332	- Improvement of stretch P2 and a part of P3	236
FW-4: Panitan - Bailan Floodway	- Construction of floodway - Minimum improvement of existing downstream channel <sup>2</sup>	1,689	- Improvement of stretches P1 and P4	1,426
FW-5: Cogon Floodway	- Construction of floodway - Minimum improvement of existing downstream channel <sup>2</sup>	1,044	- Improvement of stretch P1 (downstream from floodway inlet)	1,383
FW-6: Hamulauon Floodway	- Construction of floodway - Improvement of Pontevedra downstream stretch for reduced flood discharge	954	- Improvement of stretch P1 (downstream from floodway inlet)	946

Notes: <sup>1</sup> Breakdown of the estimated cost is contained in Appendix IV.

<sup>2</sup> Minimum required improvement at local places (e.g. erosion protection) in stretch downstream from floodway inlet. Cost to be assumed at 20% of full-scale low-water channel improvement.

表 5.2-3 バナイ河流域のダムサイト修復地の予備検討結果

Table 5.2-3 Preliminary Study Results of Prospective Dam Sites in Panay River Basin (1)

River System	Dam-site	Type & Scale of Dam	Geological Condition at Dam-site	Catch Area Km <sup>2</sup>	Design Flood m <sup>3</sup> /sec	Annual run-off 10 m (m <sup>3</sup> /sec-km <sup>2</sup> )	U.W.L EL.m	Total Storage 10 <sup>6</sup> m <sup>3</sup>	Sedim- Storage 10 <sup>6</sup> m <sup>3</sup>	Total Effect Storage 10 <sup>6</sup> m <sup>3</sup>	Water Utilize Storage 10 <sup>6</sup> m <sup>3</sup>	Flood Cont. Storage 10 <sup>6</sup> m <sup>3</sup>
Panay	A Site	Concrete gravity H=71.5m, L=110m V=145,000m <sup>3</sup> Spillway free over-flow type	Conglomerate, Sandstone and siltstone which are not well consolidated. Lot of water leakage is recorded in the part drilling	211.9	1,000 (200yr. flood)	560.5 (0.0839)	120	134	21	113	56.5	56.5
	B Site	Concrete gravity H=47m, L=130m V=92,000m <sup>3</sup> Spillway with gates	Andesitic volcanic breccia with many outcrop in river bed	298.8	1,120 (200yr. Flood)	632.6 (0.0839)	75	73	24	49	24.5	24.5
	C Site	Concrete gravity H=26m, L=153m V=41,500m <sup>3</sup> Spillway with gates	Andesitic volcanic breccia with same outcrop in riverbed	509.2	2,400	2,151.3	30	229	51	178	89	89
Badbaran	A Site	Rockfill H=23m, L=335m V=354,000m <sup>3</sup> Spillway with gate	Andesite and volcanic breccia. Depth to fresh rock is about 10m	258.4	2,130 (1.2x200yr. flood)	354.3 (0.0435)	42.5	115.3	37.5	77.8	35.1	42.7
	B Site	Rockfill H=23m, L=335m V=354,000m <sup>3</sup> Spillway with gate	Karatic limestone much leakage expected	290.0	2,260 (1.2x200yr. flood)	431.5 (0.0472)	35	97	29	68	34	34
Nambuaao	A Site	Concrete gravity H=44m, L=130m V=77,000m <sup>3</sup> Spillway free over-flow type	Moderately hard consolidated conglomerate, sandstone and siltstone overburden very thick	72.9	250 (200yr. Flood)	136.4 (0.0593)	90	38	7	31	15.5	15.5
	B Site	Rockfill H=15m, L=280m V=148,000m <sup>3</sup> Spillway with gate	Sandstone, conglomerate and siltstone. Site is covered with thick overburden.	216.6	910	405.2	32	72	22	50	25	25
Masyon	Masyon	Rockfill H=30m, L=385m V=480,000m <sup>3</sup> Spillway with gates		140.1	910	177.5	97	50	14	36	18	18

Table 5.2-3 Preliminary Study Results of Prospective Dam Sites in Panay River Basin (2)

River System	Dam Site	Firm disch. m <sup>3</sup> /sec	Max. disch. m <sup>3</sup> /sec	Intake H.W.L EL.m	L.W.L EL.m	T.W.L EL.m	Total Head m	Inst. Capa. KW	Depend. Output KW	Annual Energy 10 <sup>6</sup> kWh	Construction Cost P106		Energy Cost P/kWh		
											Dam	Power S. Total			
Panay	A Site	14.46	30.0	104.0	86.0	59.0	44.5 ~27.0	10,700	6,360	45.3	627.5	242.4	869.9	5.55	0.54
	B Site	12.50	25.0	68.0	61.5	39.0	29.0 ~22.5	5,700	4,400	35.5	403.7	166.3	570.0	8.24	0.47
	C Site	24.6	50.0	25.5	21.2	14.0	11.5 ~7.2	4,480	2,760	24.1	523.1	212.4	735.5	2.94	0.88
Badbaran	A Site	8.79	18.0	40.0	36.8	22.0	18.0 ~14.8	2,250	2,120	11.7	275.6	97.5	373.1	3.55	0.83
	B Site	6.5	13.0	31.5	27.5	17.0	14.5 ~10.5	1,400	990	8.7	441.7	106.1	547.8	6.50	1.21
Mambuso	A Site	3.2	6.5	83.0	73.0	35.0	28.0 ~18.0	1,440	920	6.8	297.4	63.7	361.1	9.59	0.94
	B Site	7.8	15.0	30.0	26.0	19.0	11.0 ~7.0	Head is too low. planned	Not planned	Not planned	358.4			7.17	
Maayon	Maayon	3.4	6.8	42.5	38.0	29.0	18.5 ~14.0	900	710	5.8	293.2	74.3	367.5	8.14	1.29

Remark: 1. Energy cost is tentatively calculated to be  $\frac{\text{Construction Cost of Power House} \times \text{annual cost factor}}{\text{Annual energy output}}$

Annual cost factor is taken at 0.1.

表 5.2-4 各ダム計画の概要

Table 5.2-4 General Features of Each Dam Plan

Item	Unit	Panay B	Panay C	Badbaran A	Mambusao B	Panay C (After Panay B)
<b>Reservoir</b>						
Total storage capacity	106 m <sup>3</sup>	96.0	466.0	75.5	60.2	295.0
Sediment capacity	106 m <sup>3</sup>	31.7	68.9	37.5	28.7	37.2
Effective storage capacity (for flood control)	106 m <sup>3</sup>	64.3	397.1	38.0	31.5	257.8
(for power generation)	106 m <sup>3</sup>	(33.8)	(144.8)	(38.0)	(31.5)	(130.2)
	106 m <sup>3</sup>	(30.5)	(252.3)	(0)	(0)	(127.6)
Flood water level	El. m	74.9	44.6	43.9	41.7	39.8
Surcharge water level	El. m	71.3	38.3	40.2	36.6	34.3
High water level	El. m	65.0	35.0	-	-	30.0
Low water level	El. m	56.7	25.6	36.8	33.6	23.5
<b>Dam</b>						
Type		Concrete gravity dam	Concrete gravity dam	Rockfill dam	Rockfill dam	Combined dam
Crest elevation	El. m	77.4	47.1	46.9	44.7	42.3
Crest length	m	160.0	190.0	240.0	280.0	175.0
Height	m	52.4	39.1	30.9	34.7	34.3
<b>Power Station</b>						
Maximum discharge	m <sup>3</sup> /sec	27.2	93.0	-	-	80.0
Rated head	m	31.7	14.4	-	-	10.3
Installed capacity	kW	7,100	11,000	-	-	6,800
Annual energy output	GWh	31.4	31.4	-	-	22.6
Tail water level	El. m	30.0	17.0	-	-	17.0

表 5.2-5 予備検討で選定された4つのダムの洪水制御容量

Table 5.2-5 Flood Regulating Capacity of Preliminarily Selected 4 Dams

(Unit: m<sup>3</sup>/sec)

Item	Panay B Dam	Panay C Dam <sup>/1</sup>	Panay C Dam <sup>/2</sup>	Badbaran A Dam	Mambusao B Dam
100-year flood					
- peak inflow	2,420	4,120	3,230	1,900	1,770
- outflow	1,210	824	646	950	885
25-year flood					
- peak inflow	1,250	2,120	1,700	1,080	990
- outflow	625	424	340	540	495
10-year flood					
- peak inflow	750	1,260	1,020	700	620
- outflow	375	252	204	350	310

Notes: /1 Independent scheme.

/2 With Panay B dam in upper reach, in which FSL of Panay C dam is planned to be equal to TWL of Panay B dam.



表 5.2-6 ダム製造前後の洪水水位と流量

Table 5.2-6 Flood Levels and Discharges Before and After Dam Projects  
(At Panitan Base Station)

Dam	Without Dam		With Dam	
	Flood Level (El. m)	Flood Discharge (m <sup>3</sup> /sec)	Flood Level (El. m)	Flood Discharge (m <sup>3</sup> /sec)
Panay B dam	10.30	2,670	10.19	2,610
Panay C dam <sup>/1</sup>	10.30	2,670	9.62	2,300
Panay B dam + Panay C dam <sup>/2</sup>	10.30	2,670	9.51	2,240
Badbaran A dam	10.30	2,670	10.17	2,600
Mambusao B dam	10.30	2,670	10.25	2,645

Notes: The above represents flood levels and discharges at occurrence of 100-year flood under present river channel condition.

/1 Independent scheme

/2 Scheme with Panay B dam in upper reach

表 5.2-7 ダムあり及びダムなし状態の洪水水位と流量  
(パニタン基準点・100年洪水)

Table 5.2-7 Flood Levels and Discharges under "With-dam" and "Without-dam" Conditions  
(at Panitan Station, 100-year Flood)

Alternative	Dam to be Built	Without Dams		With Dams	
		Flood Level (El. m)	Flood Discharge (m <sup>3</sup> /sec)	Flood Level (El. m)	Flood Discharge (m <sup>3</sup> /sec)
DR-1	Panay B	11.99	4,520	11.82	4,380
DR-2	Panay C <sup>/1</sup>	11.99	4,520	11.25	3,960
DR-3	Panay B + Panay C <sup>/2</sup>	11.99	4,520	11.14	3,870
DR-4	Panay B + Panay C <sup>/2</sup> + Badbaran + Mambusao B	11.99	4,520	10.64	3,520

Notes: The above represents flow conditions in confined channel (after river improvement) for both cases.

/1 Independent scheme.

/2 Scheme with Panay B dam in upper reach.

表 5.2-8 提案された長期洪水防御計画（構造物による対策）  
 - 河川区間及びダム別の評価

Table 5.2-8 Proposed Long-term Flood Control Plan  
 (LP-Structural Measures) - Evaluation  
 by River Stretch/Dam

River Stretch/ Dam	Construc- tion Cost (P x 10 <sup>6</sup> )	Annual Benefit (P x 10 <sup>6</sup> )	Present Worth <sup>/1</sup> (P x 10 <sup>6</sup> )		Net Benefit (B - C)	Remarks
			Cost (C)	Benefit (B)		
<u>Panay River</u>						
Stretch P1	1,188	28.0	550	256	-294	
" P2	201	3.3	93	33	-60	
" P3	455	0.7	210	8	-202	
" P4	38	-	18	0	-18	*
" P5	306	4.9	141	46	-95	
" P6	62	4.3	28	49	21	
" P7	262	0.3	121	3	-118	*
" P8	186	15.2	86	168	82	
" P9	134	1.5	62	14	-48	
" P10	-	-	-	-	-	
<u>Maayon River</u>						
Stretch Y1	19	-	9	0	-9	*
" Y2	202	4.6	94	52	-42	
" Y3	-	-	-	-	-	
" Y4	192	2.6	89	25	-64	
<u>Mambusap River</u>						
Stretch M1	111	0.6	52	5	-47	
" M2	407	4.1	188	43	-145	
" M3	452	8.6	209	97	-112	
" M4	-	-	-	-	-	
" M5	-	-	-	-	-	
" M6	-	-	-	-	-	
" M7	120	6.2	56	59	3	
<u>Badbaran River</u>						
Stretch B1	-	-	-	-	-	
" B2	-	-	-	-	-	
<u>Dams</u>						
Panay B dam	471	56.0	346	499	153	
<b>Total</b>	<b>4,766</b>		<b>2,352</b>	<b>1,357</b>	<b>-995</b>	<b>EIRR = 4.5%</b>

Notes: /1 Discount rate: 8% p.a. \* Partial improvement of low water channel only  
 /2 Incl. hydropower benefit. - No improvement

表 5.3-1 中期洪水防御計画代替案の比較

Table 5.3-1 Comparison of Mid-term Plan (MP) Alternatives

Alternative	Const. Cost (10 <sup>6</sup> P)	Present Worth <sup>/1</sup> (10 <sup>6</sup> P)			B/C	EIRR (%)
		Cost (C)	Benefit <sup>/2</sup> (B)	B-C		
MP-1	2,826	1,702	1,063	-639	0.6	5.8
MP-2	3,200	1,671	1,308	-363	0.8	6.7
MP-3	4,344	1,905	1,483	-422	0.8	6.6

Note: /1 At discount rate of 8% p.a.

/2 Incl. hydropower benefit

<u>Alternative</u>	<u>Proposed Facility</u>	<u>Protection Area (Ref. Section 4.2.3)</u>
MP-1	River improv. (incl. Floodway FW-5)	Alternative-3
MP-2	River improv. + Panay B dam	Alternative-3
MP-3	River improv. + Panay B dam + Panay C dam	Alternative-3

表 5.3-2 中期洪水防御計画の評価 (枠中含まず)

Table 5.3-2 Evaluation of Mid-term Flood Control Plan (MP)

- Polder not Considered

River Stretch/ Dam	Construc- tion	Present Value <sup>/1</sup> (Ex10 <sup>6</sup> )			Popula- tion Protected (1,000)	Remarks	
		Cost (C)	Benefit (B)	Net Benefit (B-C)			
<u>Panay River</u>							
Stretch P1		836.0	395	352	-43	40.8	
" P2		163.2	77	39	-38	6.5	
" P3		375.4	183	10	-173	-	*
" P4		30.6	15	0	-15	-	*
" P5		261.4	124	58	-66	7.9	
" P6		54.4	26	61	35	3.7	
" P7		245.5	119	6	-113	-	*
" P8		163.1	77	217	140	6.0	
" P9		-	-	-	-	-	
" P10		-	-	-	-	-	
<u>Maayon River</u>							
Stretch Y1		-	-	-	-	-	
" Y2		-	-	-	-	-	
" Y3		-	-	-	-	-	
" Y4		-	-	-	-	-	
<u>Mambusao River</u>							
Stretch M1		67.3	32	6	-26	0.8	
" M2		271.8	131	48	-83	4.7	
" M3		302.0	145	113	-32	4.5	
" M4		-	-	-	-	-	
" M5		-	-	-	-	-	
" M6		-	-	-	-	-	
" M7		-	-	-	-	-	
<u>Badbaran River</u>							
Stretch B1		-	-	-	-	-	
" B2		-	-	-	-	-	
<u>Dams</u>							
Panay B. dam <sup>/2</sup>		471.2	346	476	130	-	
Total		3,241.9	1,670	1,386	-284	75.9 (63%)	EIRR = 6.7%

Notes: /1 Discount rate: 8% p.a.

/2 Incl. hydropower benefit.

\* Partial improvement of low water channel only.

- No improvement.

表 5.3-3 中期洪水防御計画の評価 (輸中含む)

Table 5.3-3 Evaluation of Mid-term Flood Control Plan (MP)  
- Polder Considered

River Stretch/ Dam	Construc- tion Cost (P x 10 <sup>6</sup> )	Present Value <sup>/1</sup> (P x 10 <sup>6</sup> )			Popula- tion Protected (1,000)	Remarks
		Cost (C)	Benefit (B)	Net Benefit (B - C)		
<u>River Improvement</u>						
<u>Panay River</u>						
Stretch P1	836.0	395	352	-43	40.8	
" P2	163.2	77	39	-38	6.5	
" P3	375.4	183	10	-173	-	*
" P4	30.6	15	0	-15	-	*
" P5	261.4	124	58	-66	7.9	
" P6	54.4	26	0	-26	1.2	
" P7	245.5	119	3	-116	-	*
" P8	163.1	77	75	-2	5.2	
<u>Mambusao River</u>						
Stretch M1	67.3	32	6	-26	0.8	
" M2	271.8	131	13	-118	3.2	
" M3	302.0	145	37	-108	2.3	
<u>Polder Plan</u> <sup>/2</sup>						
Dao	55	56	102	46	2.5	Stretch P6
Cuartero	57	59	236	177	0.8	" P8
Sigma	42	43	61	18	1.5	" M2
Mambusao	78	80	130	50	3.2	" M3
<u>Dam</u>						
Panay B dam <sup>/3</sup>	471.2	346	476	130	-	
<b>Total</b>	<b>3,473.9</b>	<b>1,908</b>	<b>1,598</b>	<b>-310</b>	<b>75.9</b> <b>(63%)</b>	<b>EIRR</b> <b>= 7.0%</b>

Notes: <sup>/1</sup> Discount rate: 8% p.a.

<sup>/2</sup> Plans to be selected in Short-term Plan (See Subsection 5.4-4).

<sup>/3</sup> Incl. hydropower benefit.

\* Partial improvement of low water channel only.

表 5.3-4 中期計画の段階施工の評価

Table 5.3-4 Phasing of Piece-mill Works Proposed for Mid-term Implementation

Work	Net Present Value (10 <sup>6</sup> Peso)			
	(Year of Completion)			
	2000	2005	2010	2015
<u>River Improvement</u>				
Stretches P1 + P2 <sup>/1</sup>	-53	-6	+18	+27
Stretches P3 to P5 <sup>/2</sup>	-214	-140	-96	-62
Stretches P6 to P8 <sup>/3</sup>	-121	-77	-48	-30
Stretches M1 to M3 <sup>/4</sup>	-213	-140	-92	-60
<u>Polder Plan<sup>/5</sup></u>				
Dumalag	-20	-12	-8	-5
Tapaz	-33	-22	-15	-10
Maayon	+5	+8	+8	+8
Jamindan	+5	+9	+11	+11
Dumarao	-19	-9	-3	+0

Notes: + Project to be viable at this implementation phasing

<sup>/1</sup> Downstream from Panitan

<sup>/2</sup> Panitan - Mambusao confluence

<sup>/3</sup> Mambusao confluence - Badbaran confluence

<sup>/4</sup> Mambusao river downstream stretches

<sup>/5</sup> Polder plans at other towns were not examined, since they are to be included in short-term implementation programs

(See Subsection 5.4.4 hereinafter).

表 5.4-1 輪中計画の経済評価

Table 5.4-1 Economic Evaluation of Polder Plans

Location	Construction Cost (₱ x 10 <sup>6</sup> )	Present worths of; /1 (₱ x 10 <sup>6</sup> )			B/C	EIRR (%)
		Cost (C)	Benefit (B)	Net Benefit (B - C)		
<u>Panay River</u>						
Pontevedra	64	66	220	154	3.4	21.4
Panay	28	28	8	-20	0.3	1.6
Panitan	49	51	51	0	1.0	8.0
Dao*	55	56	102	46	1.8	12.7
Cuartero*	57	59	236	177	4.0	25.7
Dumalag	37	38	7	-31	0.2	-
Tapaz	48	50	1	-49	0.0	-
<u>Maayon River</u>						
Maayon	49	50	47	-3	0.9	7.5
<u>Mambusao River</u>						
Sigma*	42	43	61	18	1.4	10.5
Mambusao*	78	80	130	50	1.6	11.6
Jamindan	39	40	36	-4	0.9	7.4
<u>Badbaran River</u>						
Dumarao	58	60	24	-36	0.4	3.1

Notes: \* Plans finally selected for inclusion in SP.

- No EIRR value.



表 5.4-2 短期洪水防御計画（第一案）の評価—輪中堤防御地域を除く

Table 5.4-2 Evaluation of Short-term Flood Control Plan SP-1  
(Excluding Areas to be separately protected by Polders)

River Stretch/ Dam	Construc- tion Cost (¥ x 10 <sup>6</sup> )	Present Value <sup>/1</sup> (¥ x 10 <sup>6</sup> )			B/C	EIRR (%)
		Cost (C)	Benefit (B)	Net Benefit (B - C)		
<b>SP-1 A : Protection of 4 stretches</b>						
Stretch P1	458	266	385	119	1.4	10.3
" P2	131	78	28	-50	0.4	3.8
" P3	304	187	10	-177	-	-
" P4	22	13	0	-13	-	-
" P5	201	119	58	-61	0.5	4.8
Total	1,116	663	481	-182	0.7	6.4
<b>SP-1 B : Protection of 2 stretches</b>						
Stretch P1	458	220	337	117	1.5	10.6
" P2 <sup>/2</sup>	131	65	25	-40	0.4	4.1
Total	589	285	362	77	1.3	9.4
<b>SP-1 C : 25-year Flood Protection (for comparison)</b>						
Stretch P1	836	411	363	-48	0.9	7.4
" P2 <sup>/2</sup>	163	81	40	-41	0.5	5.0
Total	999	492	403	-89	0.8	7.0

Note: <sup>/1</sup> Discount rate: 8% p.a.

<sup>/2</sup> To be improved as an integral part of P1.

表 5.4-3 短期洪水防御計画（第二案）の評価—輪中堤防御地域を除く

Table 5.4-3 Evaluation of Short-term Flood Control Plan SP-2  
(Excluding Areas to be separately protected by Polders)

River Stretch/ Dam	Construc- tion Cost (¥ x 10 <sup>6</sup> )	Present Value <sup>/1</sup> (¥ x 10 <sup>6</sup> )			B/C	EIRR (%)
		Cost (C)	Benefit (B)	Net Benefit (C - B)		
<b>SP-2 A : Protection of 4 stretches</b>						
Stretch P1	180	82	78	-4	1.0	7.7
" P2	46	22	2	-20	0.1	<u>-/2</u>
" P3	114	60	7	-53	0.1	-
" P4	9	5	1	-4	0.2	-
" P5	64	30	28	0	1.0	7.6
<b>Total</b>	<b>413</b>	<b>199</b>	<b>116</b>	<b>-81</b>	<b>0.6</b>	<b>4.9</b>
<b>SP-2 B : Protection of 2 stretches</b>						
Stretch P1	180	82	78	-4	1.0	7.7
" P2	46	22	2	-20	0.1	-
<b>Total</b>	<b>226</b>	<b>104</b>	<b>78</b>	<b>-26</b>	<b>0.8</b>	<b>6.3</b>

Note: /1 Discount rate: 8% p.a.

/2 - indicates no EIRR.

表 5.4-4 部分改修工事の費用・便益比較

Table 5.4-4 Cost-Benefit Comparison of Ad-hoc Improvement Works

Item	Proposed Work	
	Lowering of Existing Mambusao Weir	Enlargement of Channel at Cuartero & Dao
Estimated Construction Cost (₱ x 10 <sup>6</sup> )	19.4	44.6
Present Worth (₱ x 10 <sup>6</sup> )		
- Cost	10.1	23.3
- Benefit	5.8	19.5
- Net benefit	-4.3	-3.8
Benefit-Cost Ratio (B/C)	0.6	0.8
EIRR (%)	3.9	6.5

Note: Discount rate: 8% p.a.

表 5.4-5 パニタン～パナイ～ポンテベドラ区域の開発計画比較

Table 5.4-5 Comparison of Development Plans  
in Panitan - Panay - Pontevedra Areas

Proposed Project	Protec- tion Level (Year)	Contruc- tion Cost (P x 10 <sup>6</sup> )	NPV <sup>/1</sup> (P x 10 <sup>6</sup> )	EIRR (%)	Popula- tion Protected (1,000)
<u>Case-A:</u>					
- River improvement SP-1B	10	589	77	9.4	47.3
- Panitan - Panay Irrigation	-	183	88	11.7	-
Total			165	10.1	47.3
<u>Case-B:</u>					
- Polder at Pontevedra	100	64	154	21.4	3.0
- Residual damage due to absence of flood <sup>/2</sup> protection works	-	-	-207	8.0	2.4
Total			-53		5.4
<u>Case-C:</u>					
- Residual damages due to absence of flood <sup>/2</sup> protection works	-	-	-362	-	0

Notes: Case-A : Whole area will be protected by river improvement work.

Case-B : Only Pontevedra and Panitan towns will be protected by polder dyking, leaving other areas unprotected.

Case-C : No protection by structural measures.

<sup>/1</sup> : Present worth of net benefit, discounted at 8% p.a.

<sup>/2</sup> : Corresponds to flood damage reduction attainable by "10-year flood" protection work.

表 5.4-6 提案された短期計画（構造物による対策）

Table 5.4-6 Proposed Short-term Plans - Structural Measures

Type and Location of Work	Construction Cost (P x 10 <sup>6</sup> )	Net/ <sup>1</sup> Benefit (P x 10 <sup>6</sup> )	EIRR (%)	Population Protected (1,000)
<b>River Improvement:</b>				
- Stretches P1 & P2 (SP-1 B plan)	589	77	9.4	47.3
<b>Multipurpose Dam:</b>				
- Panay B dam	471	130	11.0	-
<b>Polder:</b>				
- Dao	55	46	12.7	2.5
- Cuartero	57	177	25.7	0.8
- Sigma	42	18	10.5	1.5
- Mambusao	78	50	11.6	3.2
<b>Total</b>	<b>1,292</b>	<b>498</b>	<b>11.5</b>	<b>55.3 (47%)</b>

Notes: <sup>1</sup> Discount rate used: 8% p.a.

表 5.5-1 非施設的対策の工事単価

Table 5.5-1 Unit Cost of Non-structural Measures

(Unit: ¥x10<sup>3</sup>)

Work Item	Estimated Cost
<b>1. Flood Plain Management</b>	
1) Management office expenditures (per 100 km <sup>2</sup> of flood area)	
- Personnel cost (per year)	
Project Manager	1 persons x 50 = 50
Engineer	3 " x 40 = 120
Overseer	6 " x 30 = 180
Assistants incl. clerks	6 " x 20 = 120
Others	6 " x 20 = 120
Sub-total	22 persons 590
- Operating expenditures per year (100% of personnel cost)	590
Total cost per year	1,180
2) Initial Cost	
- Initial costs for building, equipment, vehicles, etc. for management office (per 100 km <sup>2</sup> )	3,500
- Flood area mapping (per km <sup>2</sup> )	50
<b>2. Structural Change of Buildings (per no.)</b>	
- Residential	10
- Non-residential	60
<b>3. Relocation of Housings (per no.)</b>	
1) Resettlement	
- Residential	40
- Non-residential	200
- Public facilities	50% of above
2) Procurement of land (per no.)	
- Residential (300 m <sup>2</sup> /no.)	8
- Non-residential (0.1 ha/no.)	25
- Public facilities	100% of above

表 5.5-2 非施設の対策の評価

Table 5.5-2 Evaluation of Non-structural Measures

(Unit: ₱ x 10<sup>6</sup>)

River Stretch/ Major Town	NS-1: Flood Plain Management		NS-2: Structural Change		NS-3: Relocation of Housing		Pro- posed Plan	
	Cost <sup>/1</sup>	NPV	Cost	NPV	Cost	NPV		
<b>River Stretch</b>								
Panay	P1	8.9	+5.7 <sup>/3</sup>	94.1	-31.9	677	-217	(NS-1)
	P2	0.8	+1.3	16.4	-8.7	115	-42	(NS-1)
	P3	1.0	-0.4	7.2	-3.0	54	-18	NS-1
	P4	0.1	-0.1	0.3	-0.1	3	-7	"
	P5	2.4	-0.5	13.4	-5.1	101	-30	"
	P6	0.1	-0.1	2.4	-1.6	18	-11	"
	P7	1.1	-1.7	2.1	-0.5	14	-2	"
	P8	1.5	+1.9	10.1	-2.0	74	-11	"
	P9	1.1	-0.9	10.5	-11.9	71	-65	"
	P10	1.5	-1.7	10.4	-8.9	74	-47	"
Maayon	Y1	0.1	+0.04	0.2	+0.03	2	+0.08	NS-3
	Y2	1.0	+2.4	10.5	-2.2	72	-7	NS-1
	Y3	0.3	-0.2	1.2	-0.3	10	-3	"
	Y4	1.0	-0.1	4.5	-0.9	34	-8	"
Mambusao	M1	0.6	-0.8	1.3	-0.4	10	-1	"
	M2	0.5	+0.1	5.8	-3.0	43	-17	"
	M3	0.8	+1.0	2.9	+1.8	21	+11	NS-3
	M4	0.4	+0.1	4.3	-1.8	30	-10	NS-1
	M5	0.9	+1.3	5.0	-2.1	36	-11	"
	M6	0.5	+1.0	11.0	-5.7	75	-14	"
	M7	2.7	-0.8	19.2	-17.3	222	-54	"
Badbaran	B1	0.2	-0.2	1.4	-0.7	10	-5	"
	B2	0.9	-1.2	3.6	-1.7	27	-48	"
<b>Total</b>		28.7	+6.2	232.6	-108.0	1,793	-617	
<b>Major Town<sup>/2</sup></b>								
	Dao	0.1	+4.4 <sup>/4</sup>	10.8	-3.3	70	-2	
	Cuartero	0.1	+10.6	7.9	+10.5	48	+65 <sup>/4</sup>	
	Sigma	0.1	+2.7 <sup>/4</sup>	7.5	-2.7	48	-5	
	Mambusao	0.1	+5.7 <sup>/4</sup>	13.0	-3.5	85	-0.1	
<b>Total</b>		0.4	+23.4	39.2	+1.0	251	-57.9	

- Notes: NPV Net present value of benefit, discounted at 8% p.a.
- <sup>/1</sup> Initial cost only.
- <sup>/2</sup> Selected towns where polder is conceived in Short-term Plan.
- <sup>/3</sup> Subject to further evaluation in Subsection 10. - .
- <sup>/4</sup> Net benefit is less than that accrued by polder plan (See Table 5.4-5). Therefore polder plan is proposed.

表 5.6-1 洪水予報システムの設備費

Table 5.6-1 Installation Cost of Flood Forecasting System

Item	Foreign Currency Portion (¥ x 10 <sup>3</sup> )	Local Currency Portion (₱ x 10 <sup>3</sup> )
<b>I. CIVIL WORK</b>		
1. Station Houses	50,000	1,000
2. Tower/Telepoles	30,000	2,000
3. Installation	75,000	5,000
Sub-total	<u>155,000</u>	<u>8,000</u>
<b>II. TELECOMMUNICATION WORK</b>		
1. Equipment and Materials	400,000	-
2. Installation/Adjustment & Testing	125,000	4,000
3. On-the-job Training/ Factory Training	40,000	500
4. Operation and Maintenance Services	35,000	400
Sub-total	<u>600,000</u>	<u>4,900</u>
<b>III. CONTINGENCY</b>	<u>145,000</u>	<u>2,100</u>
<b>IV. TOTAL</b>	<u>900,000</u>	<u>15,000</u>
	(≒ US\$3,830,000)	(≒ US\$830,000)



表 5.6-2 洪水予警報システムの経済計画

Table 5.6-2 Economic Evaluation of Flood Forecasting and Warning System

Item	Amount/Indices
Capital Cost (¥ x 10 <sup>6</sup> ) :	84
O & M Cost <sup>/1</sup> (¥ x 10 <sup>6</sup> /yr) :	4.2
Annual Damage Reduction (¥ x 10 <sup>6</sup> ) :	2.3
Present Worth (¥ x 10 <sup>6</sup> ) <sup>/2</sup>	
- Cost (C) :	83
- Benefit (B) :	43
B - C :	-40
B/C :	0.5
EIRR (%) :	4.7

Notes: /1 5% of capital cost per year.

/2 Discount rate: 8% p.a.

表 5.7-1 洪水防御計画一長・中・短期計画案

Table 5.7-1 Summary of Flood Control Projects for Long-, Mid-, and Short-term Plans (1)

Location of Work	Q'ty	Long-term Plan (LP)	Mid-term Plan (MP)	Short-term Plan (SP)
<b>Design Flood</b>				
<b>River Improvement</b>				
<b>Panay River:</b>				
(1) Pontevedra river (P1)	6.1 km	Partial improvement of existing channel between Cogon floodway inlet and Hamulaon bifurcation	- do left -	- do left -
(2) Cogon floodway	9.5 km	Construction of a bypass floodway (Q=3,900 m <sup>3</sup> /sec)	- do left (Q=2,200 m <sup>3</sup> /sec) -	- do left (Q=1,000 m <sup>3</sup> /sec) -
(3) Cogon floodway inlet - Panitan (P1 and P2)	6.5 km	Improvement with levees	- do left -	- do left -
(4) Panitan - Maayon confluence (P3)	10.2 km	Improvement of existing channel with a levee for partial protection of right bank area	(No improvement)	(No improvement)
(5) Maayon confluence - Mambusao confluence (P4 and P5)	2.2 km	Partial improvement of existing channel, only at bottleneck sections (P4)	(No improvement)	(No improvement)
(6) Mambusao confluence - Badbaran confluence (P6, P7 and P8)	7.0 km 7.2 km	Improvement with levees (P5) Improvement with levees (P6 and P8)	(No improvement) (No improvement)	(No improvement) (No improvement)
(7) Badbaran confluence - Dumalag (P9)	8.8 km 8.6 km	Improvement of existing channel with a levee for protection of partial area on left bank Improvement with levees	(No improvement) (No improvement)	(No improvement) (No improvement)
<b>Maayon River:</b>				
(1) Downstream of Ilas confluence (Y1)	1.8 km	Partial improvement of existing channel, only at bottleneck sections	(No improvement)	(No improvement)
(2) Along Maayon and Ilas river (Y2 and Y4)	18.4 km	Construction of back levees, with improvement of existing channels	(No improvement)	(No improvement)

Table 5.7-1 Summary of Flood Control Projects for Long-, Mid-, and Short-term Plans (2)

Location Work	Q'ty	Long-term Plan (LP)	Mid-term Plan (MP)	Short-term Plan (SP)
<b>Mambusao River:</b>				
(1) Downstream of Mambusao (M1, M2 and M3)	21.2 km	Improvement of existing channel with low levees. Construction of a bypass channel on right bank at Mambusao town.	(No improvement)	(No improvement)
(2) Balacuan river (M7)	8.6 km	Construction of a drainage sluice at Balacuan river mouth, with partial improvement of existing channel, only at bottleneck sections.	(No improvement)	(No improvement)
<b>Polder Plan</b>				
(1) Dao town (P6)	1.17 km <sup>2</sup>	(Not applicable. To be protected by river improvement work.)	Construction of polder dyke (100-year flood protection)	Construction of polder dyke (100-year flood protection)
(2) Cuartero town (P8)	0.49 km <sup>2</sup>	- do above -	- do above -	- do above -
(3) Sigma town (M2)	0.47 km <sup>2</sup>	- do above -	- do above -	- do above -
(4) Mambusao town (M3)	1.03 km <sup>2</sup>	- do above -	- do above -	- do above -
(5) Maayon town	0.64 km <sup>2</sup>	- do above -	Staged construction of polder dyke	(No work)
(6) Jamindan town	0.34 km <sup>2</sup>	- do above -	- do above -	(No work)
(7) Dumarao town	0.48 km <sup>2</sup>	- do above -	- do above -	(No work)
<b>Multipurpose Dam</b>				
Pansy B dam		Construction of a flood control dam, with installation of hydropower facilities.	- do left -	- do left -
<b>Non-structural Measures</b>				
(1) Flood plain management	338 km <sup>2</sup>	Application to areas where protection by structural measures is not scheduled	- do left -	Applicable to all areas including P1 and P2 areas (338 km <sup>2</sup> )
(2) Relocation of housings	11 km <sup>2</sup>	(Not planned)	(Not planned)	To be applied to subdivision areas Y1 and M3 (but excluding Mambusao town), subject to further review in detailed survey.
<b>Flood Forecasting and Warning System</b>				
		To be installed.	To be installed.	To be installed.

表 6.3-1 パニタン-パナイ地区の灌漑用単位取水要求量

Table 6.3-1 Unit Irrigation Diversion Requirement, Panitan-Panay Area

Year	(Unit: lit/s/ha)											
	Jan.	Feb.	Mar	Apr	May	Jun	Jul	Aug	Sep	Oct	Nov	Dec
1950	0.03	0.34	0.38	0.49	0.90	0.55	0.72	0.11	0.15	0.78	0.49	0.53
1951	0.16	0.36	0.64	0.67	0.66	1.46	0.27	0.44	0.17	1.06	0.23	0.04
1952	0.15	0.32	0.55	0.80	0.98	0.79	0.27	0	0.20	0.11	0.23	0.28
1953	0.11	0.33	0.59	0.71	1.45	0.12	0.13	0.03	0.22	0.48	0.26	0
1954	0.18	0.33	0.28	0.70	0.87	0.30	0.22	0.11	0.27	1.08	0.53	0.04
1955	0	0.36	0.66	0.78	1.05	0.67	0.36	0.06	0.21	0.63	0	0.66
1956	0.11	0.33	0.62	0.19	0.57	1.07	0	0	0.21	0.62	0.64	0
1957	0.02	0.36	0.59	0.58	1.50	0.77	0.21	0.11	0.25	0.81	0.64	0.83
1958	0.15	0.36	0.47	0.63	1.37	0.88	0.27	0	0.33	0.27	0.05	0.71
1959	0.18	0.38	0.52	0.79	1.35	0.86	0	0.22	0.19	1.11	0.25	0
1960	0.19	0.29	0.41	0.57	0.88	0.94	0.38	0	0.15	0.64	0.31	0.66
1961	0.22	0.35	0.57	0.78	0.97	0.79	0.75	0.26	0.21	1.20	0.63	0.79
1962	0.13	0.34	0.55	0.65	0.94	0.95	0.04	0	0.14	0.93	0.22	0.87
1963	0.20	0.37	0.64	0.65	1.33	1.12	0	0	0.20	0.95	0.87	0.64
1964	0.22	0.31	0.68	0.78	0.72	0.71	0	0.10	0.15	0.48	0	0.52
1965	0.07	0.37	0.53	0.60	1.15	0.84	0.54	0.08	0.20	1.23	0.72	0.23
1966	0.14	0.38	0.73	0.75	0.32	0.80	0	0.02	0.19	0.53	0.31	0.24
1967	0	0.30	0.67	0.73	1.16	0.99	0.34	0.21	0.32	0.91	0.09	0.82
1968	0.13	0.35	0.68	0.79	1.46	0.99	0.16	0.12	0.25	0.70	0.30	0.37
1969	0.19	0.36	0.67	0.77	0.97	0.90	0	0	0.26	1.23	0.89	0.26
1970	0.18	0.29	0.45	0.80	1.59	0.57	0.11	0.29	0.18	0	0	0.37
1971	0.08	0.33	0.40	0.43	0.65	0	0	0.22	0.20	0.67	0	0.64
1972	0	0.36	0.55	0.74	1.47	0.65	1.05	0.32	0.21	1.18	0.25	0.28
1973	0.24	0.37	0.62	0.76	1.59	1.21	0.10	0	0.09	0.86	0	0
1974	0.12	0.33	0.67	0.73	1.28	1.07	0.14	0.29	0.27	0.50	0.32	0.05
1975	0.10	0.33	0.70	0.19	1.19	0.84	0.51	0.11	0.15	0	0.39	0
1976	0.20	0.35	0.64	0.76	0.97	1.12	0.58	0	0.26	0.98	0	0
1977	0.10	0.29	0.64	0.66	1.26	0.55	0.27	0.12	0.22	1.13	0.92	0.65
1978	0.18	0.36	0.69	0.59	1.14	0.70	0.50	0.32	0.20	0.78	0.36	0.11
1979	0.16	0.37	0.70	0.35	1.15	0.38	0.60	0.06	0.24	1.00	0.89	0.24
1980	0.14	0.33	0.44	0.68	1.23	0	0.19	0.19	0.27	0.94	0.35	0.46
1981	0.22	0.37	0.69	0.71	1.35	0.84	0.66	0.29	0.21	0.99	0.41	0.46
1982	0.17	0.36	0.46	0.77	1.15	0.88	0.82	0	0.26	1.27	0.81	0.77
1983	0.22	0.38	0.71	0.80	1.56	0.61	0	0.11	0.20	0.57	0.33	0.31

表 6.3-2 マンブサオ地区 (ケース1) の灌漑用単位取水要求量

Table 6.3-2 Unit Irrigation Diversion Requirement, Mambusao Area, Case-1

(Unit: lit/s/ha)												
Year	Jan	Feb	Mar	Apr	May	Jun	Jul	Aug	Sep	Oct	Nov	Dec
1976	0	0.97	0.25	0	0.98	0.92	0.30	0.15	0.03	0	0.66	0
1977	0.16	0.23	0.20	0	1.00	0.35	0.33	0.17	0.05	0	0.62	0.86
1978	0.43	0.96	0.34	0	0.84	0.36	0.29	0.21	0.02	0	0.83	0.24
1979	0.69	1.17	0.31	0	0.93	0.38	0.14	0.06	0.13	0	0.48	0.58
1980	0.20	0.83	0.15	0	1.24	0	0	0	0	0	0.39	0.26
1981	0.01	0.70	0.33	0	0.62	0.82	0.23	0.21	0	0	0.56	0.16
1982	0	0.41	0.22	0	0.98	0.42	0.51	0	0.03	0	0.93	0.97

表 6.3-3 マンブサオ地区 (ケース2) の灌漑用単位取水要求量

Table 6.3-3 Unit irrigation Diversion Requirement, Mambusao Area, Case-2

(Unit: lit/s/ha)												
Year	Jan	Feb	Mar	Apr	May	Jun	Jul	Aug	Sep	Oct	Nov	Dec
1976	0	0.97	0.25	0	0.26	1.21	0.37	0.21	0.45	0	0.66	0
1977	0.16	0.23	0.20	0	0.26	0.72	0.40	0.23	0.51	0	0.62	0.86
1978	0.43	0.96	0.34	0	0.22	0.73	0.36	0.27	0.44	0	0.83	0.24
1979	0.69	1.17	0.31	0	0.25	0.75	0.21	0.11	0.76	0	0.48	0.58
1980	0.20	0.83	0.15	0	0.33	0.31	0	0	0	0	0.39	0.26
1981	0.01	0.70	0.33	0	0.17	1.12	0.30	0.27	0.10	0	0.56	0.16
1982	0	0.41	0.22	0	0.26	0.78	0.58	0	0.45	0	0.93	0.97

表 6.3-4 灌溉用水需要量

Table 6.3-4 Irrigation Water Demand

(Unit: m<sup>3</sup>/sec)

Name of scheme	Area (ha)	Jan.	Feb.	Mar.	Apr.	May	Jun.	Jul.	Aug.	Sep.	Oct.	Nov.	Dec.
<u>NIS</u>													
(1) Panitan-Panay	3,250	0.42	1.14	2.21	2.57	4.75	3.22	0.52	0.39	0.81	2.26	0.98	1.20
(2) Mambusao	1,720												
Case-1		1.48	2.51	0.66	0	2.10	1.97	0.64	0.32	0.06	0	1.78	0.51
Case-2		1.48	2.51	0.66	0	0.56	2.60	0.79	0.45	0.97	0	1.78	0.51
<u>CIS</u>													
(1) Tapaz	300	0.21	0.35	0.09	0	0.29	0.28	0.09	0.05	0.01	0	0.25	0.07
(2) Dumalag	300	0.21	0.35	0.09	0	0.29	0.28	0.09	0.05	0.01	0	0.25	0.07
(3) Lemery	300	0.21	0.35	0.09	0	0.29	0.28	0.09	0.05	0.01	0	0.25	0.07
(4) Dumarao	550	0.40	0.64	0.17	0	0.54	0.51	0.17	0.08	0.02	0	0.46	0.13
(5) Cuartero	650	0.45	0.76	0.20	0	0.64	0.60	0.20	0.10	0.02	0	0.54	0.16
(6) Jagnaya	150	0.10	0.18	0.05	0	0.15	0.14	0.05	0.02	0.01	0	0.12	0.04
(7) Iles	1,000	0.69	1.17	0.31	0	0.98	0.92	0.30	0.15	0.03	0	0.83	0.24

表 6.3-5 取水システム代替案の概要比較

Table 6.3-5 Comparison on General Feature for  
Alternative Intake Systems

Item	Pump System	Gravity System
(1) Intake Facility	Pump station and headreach of about 2 km	Headworks and headreach of about 7 km
(2) Location of Intake Facility	On the both right and left banks of the Panay River about 1.0 km upstream of the Panitan bridge (See Figure 6.3-3)	On the Panay River about 2.5 km upstream of the Panitan bridge (See Figure 6.3-3)
(3) Potential Area	3,400 ha	3,400 ha
(4) Irrigable Area	3,250 ha	1,250 ha
(5) Intake Water Level	No limitation, providing whole potential area with irrigation water	Maximum is El. 5 m, so as not to make paddy field in the upstream reaches submerge under the checked water
(6) Initial Investment	Cheap	Costly
(7) Construction	No coffering works	Need coffering works and longer construction period
(8) Operation and Maintenance	Complicated, costly, but accurate diversion of water	Easy, cheap, but rough diversion of water

表 6-3-6 取水システム代替案の経済比較

Table 6.3-6 Economic Comparison on Alternative Intake Systems

Item		Pump System	Gravity System
(1)	Irrigation Area (ha)	<u>3,250</u>	<u>1,250</u>
(2)	Initial Investment (₱ x 10 <sup>3</sup> )	<u>40,500</u>	<u>130,230</u>
	(a) Preparatory works	918	6,948
	(b) Civil works	11,556	86,958
	(c) Pump	7,632	-
	(d) Mechanical works	4,950	16,632
	(e) Electrical works	7,362	2,700
	(f) Miscellaneous	2,808	-
	(g) Contingency	5,274	16,992
(3)	Annual O & M Cost (₱ x 10 <sup>3</sup> )	<u>4,050</u>	<u>720</u>
	(a) Personnel charge	90	72
	(b) Maintenance charge	270	648
	(c) Electric power charge <sup>/1</sup>	3,690	-
(4)	Annual Equivalent Cost of Initial Investment (₱ x 10 <sup>3</sup> )	<u>3,618</u>	<u>10,908</u>
	(a) Civil works <sup>/2</sup>	1,170	8,820
	(b) Other works <sup>/3</sup>	2,448	2,088
(5)	Total Annual Equivalent Cost ((3) + (4)) (₱ x 10 <sup>3</sup> )	<u>7,668</u>	<u>11,628</u>
(6)	Total Annual Equivalent Cost per ha ((5)/(1)) (₱/ha)	<u>2,359</u>	<u>9,302</u>

Notes: <sup>/1</sup> CAPELCO's electric charge of 2.495 ₱/kWh is applied.

<sup>/2</sup> Useful life; 50 years, discount rate; 8%

<sup>/3</sup> Useful life; 25 years, discount rate; 8%



表 6.3-7 パニタン-パナイ地区のプロジェクト設備概要

Table 6.3-7 General Feature of Project Facilities  
for Panitan-Panay Area

Item	Features	
1. Source of Irrigation Water	: the Panay river	
2. Net Irrigation Area	: 3,250 ha	
	<u>P-1 Area</u>	<u>P-2 Area</u>
3. Design Diversion Requirement	: 1.37 m <sup>3</sup> /sec	3.37 m <sup>3</sup> /sec
4. Intake Facility	:	
(1) Pump station	:	
- Location	: right bank	left bank
- Commanding area	: 940 ha	2,310 ha
- Pump bore	: φ 450 mm	φ 800 mm
- Number of pump	: 2 nos.	3 nos.
- Type of pump	: vertical mixed flow	
- Design discharge	: 82.2 m <sup>3</sup> /min	202.2 m <sup>3</sup> /min
- Total head	: 7 m	8 m
- Design water level	:	
Flood water level	: El. 10.2 m	El. 10.2 m
Normal water level	: El. 1.5 m	El. 1.5 m
Low water level	: El. 0 m	El. 0 m
(2) Headreach	:	
- Type of canal	: trapezoidal concrete lined	
- Side slope of canal	: 1:1.5	
- Width of inspection road	: 4.0 m	
- Length	: 0.6 km	1.2 km
(3) Related structure	:	
- Culvert	: 2 nos.	4 nos.
- Crossdrain	: -	1 no.
- Bifurcation structure	: -	1 no.
5. Irrigation Facilities	:	
(1) Main canal	:	
- Type of canal	: trapezoidal earth canal	
- Side slope of canal	: 1:1.5	
- Width of inspection road	: 4.0 m	
- Length	: 2.3 km	15.5 km
(2) Lateral canal	:	
- Type of canal	: trapezoidal earth canal	
- Side slope of canal	: 1:1.5	
- Width of inspection road	: 4.0 to 2.5 m	
- Length	: 16.0 km	23.6 km
(3) Related structures	:	
- Culvert	: 6 nos.	37 nos.
- Check structure	: 12 nos.	25 nos.
- Drop structure	: -	4 nos.
- Headgate	: 3 nos.	8 nos.
- Turnout	: 38 nos.	62 nos.
- Spillway	: 2 no.	4 nos.
- Aqueduct	: 5 nos.	5 nos.
- Crossdrain	: 2 no.	2 nos.
- Terminal structure	: 5 nos.	6 nos.
- Parshall flume	: 5 nos.	6 nos.
5. Drainage Facilities	:	
(1) Main drain	:	
- Type of canal	: trapezoidal earth canal	
- Side slope of canal	: 1:1.5	
- Length	: 0.7 km	12.3 km
(2) Collector drain	:	
- Type of canal	: trapezoidal earth canal	
- Side slope of canal	: 1:1.5	
- Length	: 6.3 km	11.4 km
(3) Related structures	:	
- Drainage culvert	: 2 no.	2 nos.
- Drainage inlet	: 18 nos.	59 nos.
7. On-Farm Development	:	
(1) Farm ditch	:	
- Type of canal	: trapezoidal earth canal	
- Side slope of canal	: 1:1.0	
- Length	: 48.9 km	191.1 km
(2) Farm drain	:	
- Type of canal	: trapezoidal earth canal	
- Side slope of canal	: 1:1.0	
- Length	: 14.9 km	147.6 km
(3) Related structures	:	
- Culvert	: 41 nos.	102 nos.
- Division work	: 85 nos.	208 nos.
- Overchute	: -	1 no.
- Crossdrain	: 5 nos.	11 nos.
- Drainage culvert	: 3 no.	1 nos.

表 6.3-8 マンブサオ地区のプロジェクト設備概要

Table 6.3-8 General Feature of Project Facilities  
for Mambusao Area

Item	Features
1. Source of Irrigation Water	: the Mambusao river
2. Net Irrigation Area	: 2,145 ha
- Existing area	: 1,640 ha
- Extension area	: 505 ha
3. Design Diversion Requirement	: 2.60 m <sup>3</sup> /sec
4. Intake Facility	
- Design intake capacity	: 2.60 m <sup>3</sup> /sec
- Design intake water level	: EL 18.4 m
- Rehabilitation	: repair of apron : bank protection : repair of intake gate
5. Irrigation Facilities & Road	
(1) Main canal	
- Type of canal	: trapezoidal earth canal
- Side slope of canal	: 1 : 1.5
- Width of inspection road	: 4 m (effective width 3 m)
- Length	: 14.6 km (rehabilitation)
(2) Lateral canals	
- Type of canal	: trapezoidal earth canal
- Side slope of canal	: 1 : 1.5
- Width of inspection road	: 4 to 2.5 m (effective width : 3-1.7 m)
- Length	: 33.2 km (rehabilitation) : 5.5 km (new construction)
(3) No. of related structure	
	<u>Rehab.</u> <u>Const.</u> <u>Total</u>
- Culvert	: 13      10      23
- Syphon	: 31      3      34
- Check structure	: 1      12      13
- Drop structure	: 0      5      5
- Head gate	: 9      1      10
- Turnout	: 0      63      63
- Cross drain	: 6      28      34
- Parshall flume	: 0      9      9
6. Drainage Facilities	
- Construction of drain	: 25 km
- Rehabilitation of creek	: 11 km
- No. of drainage culvert	: 5 nos.
- No. of drainage culvert	: 48 nos.
7. On-farm Development	
- Construction of farm ditch	: 150 km
- Construction of farm drain	: 105 km
- No. of division box	: 190 nos.
- No. of culvert	: 90 nos.

表 6.5-1 プロジェクトを実施する場合の純生産価値  
Table 6.5-1 Net Production Value With Project

	Panaitan - Panay Area (1.5 ha)					Mambusao Area (2.2 ha)				
	Irrigated Paddy		Nung	Other	Total/1	Irrigated Paddy		Other	Total/1	
	1st	2nd				1st	2nd			
1. Area Planted (ha)	1.4	1.4	0.7	0.1	3.6	2.1	2.1	0.1	4.3	
2. Unit Yield (t/ha)	5.0	5.0	1.0	12.0		5.0	5.0	12.0		
3. Farmgate Price (P/t)	4,390	4,390	7,870	1,050		4,390	4,390	1,050		
4. Gross Production Value (P)	30,730	30,730	5,509	1,260	66,969	46,095	46,095	1,260	92,190	
5. Production Cost										
5.1 Far- Inputs										
Seeds	924	924	135	14		1,386	1,386	14		
Fertilizer	3,412	3,412	478	195		5,118	5,118	195		
Agro-Chemicals	1,022	1,022	259	122		1,533	1,533	122		
Sub-Total	<u>5,358</u>	<u>5,358</u>	<u>881</u>	<u>331</u>		<u>8,037</u>	<u>8,037</u>	<u>331</u>		
5.2 Bags	420	420	42	-		630	630	-		
5.3 Labour	3,794	3,794	1,068	174		5,691	5,691	174		
5.4 Membership Fee	557	557	-	-		835	835	-		
5.5 Miscellaneous	1,013	1,013	199	51		1,519	1,519	51		
Total Cost (P)	<u>11,142</u>	<u>11,142</u>	<u>2,190</u>	<u>556</u>		<u>16,712</u>	<u>16,712</u>	<u>556</u>		
6. Net Production Value (P)	19,588	19,588	3,319	704	42,495	29,383	29,383	704	58,766	

Note. /1: Not included those amount attributed to Other crops in the calculation of Total Production Value or Cost.

表 6.5-2 プロジェクトを実施しない場合の純生産価値  
Table 6.5-2 Net Production Value Without Project

Items	Panitan - Panay Area (1.5 ha)						Mambusao Area (2.2 ha)							
	Irrigated Paddy			Rainfed Paddy			Irrigated Paddy			Rainfed Paddy				
	1st	2nd	3rd	1st	2nd	Total/2	Others/1	1st	2nd	1st	2nd	Total/2	Others/1	Total/2
1. Area Planted (ha)	0.65	0.65	0.3	0.75	0.75	3.2	0.1	1.6	1.6	0.5	0.5	4.3	0.1	4.3
2. Unit Yield (t/ha)	3.6	3.6	3.6	3.0	3.0	11.76	11.76	3.6	3.6	3.0	3.0	11.76	11.76	11.76
3. Farmgate Price (P/t)	4,390	4,390	4,390	4,390	4,390	1,050	1,050	4,390	4,390	4,390	4,390	1,050	1,050	1,050
4. Gross Production Value (P)	10,273	10,273	4,741	9,878	9,878	45,043	1,235	25,286	25,286	6,585	6,585	63,742	1,235	63,742
5. Production Cost														
5.1 Farm Inputs														
Seeds	429	429	198	495	495	14	14	1,056	1,056	330	330	14	14	14
Fertilizers	1,196	1,196	552	1,380	1,380	195	195	2,944	2,944	920	920	195	195	195
Agro-chemicals	475	475	219	548	548	122	122	1,168	1,168	365	365	122	122	122
Sub-Total	2,100	2,100	969	2,423	2,423	331	331	5,168	5,168	1,615	1,615	331	331	331
5.2 Bags	140	140	65	135	135	-	-	346	346	90	90	-	-	-
5.3 Labour	1,762	1,573	726	2,033	1,815	174	174	4,336	3,872	1,355	1,210	174	174	174
5.4 Membership Fee	258	258	119	-	-	-	-	636	636	-	-	-	-	-
5.5 Miscellaneous	426	407	187	459	437	51	51	1,049	1,002	306	292	51	51	51
Total Cost (P)	4,686	4,478	2,066	5,050	4,810	21,090	556	11,535	11,024	3,366	3,207	29,132	556	29,132
6. Net Production Value (P)	5,587	5,795	2,675	4,828	5,068	23,953	679	13,751	14,262	3,219	3,378	34,610	679	34,610

Note. /1: Calculation is made based on eggplant as representative crop of others.

/2: Not included those amount attributed to Other crops in the calculation of Total Production Value or Cost.

表 6.5-3 プロジェクトを実施する場合としない場合の農家収支  
(1984年地方市場価格)

Table 6.5-3 Farm Budget Under Without- and With-Project Conditions in the 1984 Local Market Price

Item	(Unit: Peso)			
	Panitan - Panay Area		Mambusao Area	
	Without	With/ <u>1</u> Increment	Without	With/ <u>1</u> Increment
<b>A. Farm Income</b>				
1. Crop	9,900	23,680 (+) 13,780	14,220	29,880 (+) 15,660
2. Livestock	2,500	2,500 0	2,600	2,600 0
3. Others				
Wage	4,500	4,500 0	4,500	4,500 0
Extra	200	200 0	200	200 0
<u>Sub-total</u>	<u>17,100</u>	<u>30,880 (+) 13,780</u>	<u>21,520</u>	<u>37,180 (+) 15,660</u>
<b>B. Farmer's Expenditure</b>				
1. Tax & Duties	670	2,150 (-) 1,480	860	2,910 (-) 2,050
2. Living Expenses	14,740	14,740 0	17,840	17,840 0
<u>Sub-total</u>	<u>15,410</u>	<u>16,890 (-) 1,480</u>	<u>18,770</u>	<u>20,750 (-) 2,050</u>
C. Capacity to Pay (A - B)	1,690	13,990 + 12,300	2,820	16,430 + 13,610

Note: /1 100-year flood protection

表 7.1-1 自治体毎の上工水需要予測

Table 7.1-1 Projected Public Water Requirement of Domestic and Municipal Use by Municipality

Municipality	1990	2000	2010	2020	2030
Roxas City	1,408	5,338	8,445	9,726	11,032
Cuartero	111	399	630	726	823
Dao	97	361	571	658	746
Dumalag	108	398	629	724	821
Dumarao	71	357	565	651	738
Ivisan	156	591	935	1,077	1,227
Jamindan	59	212	334	385	437
Maayon	162	609	963	1,109	1,258
Mambusao	226	840	1,330	1,532	1,737
Panay	122	463	732	843	957
Panitan	101	359	567	653	741
Pontevedra	123	458	724	834	946
Sapian	134	488	773	890	1,010
Sigma	101	365	577	664	753
Tapaz	86	326	516	594	674
Lemery*	91	365	578	666	756
Bingawan*	108	391	619	713	809
Total	3,264	12,320	19,488	22,445	25,460

Note; \* : Municipality of Iloilo

表 8.1-1 NPC 及び本調査による電力需要予測

Table 8.1-1 NPC Demand Forecasts and Study Forecasts

Year	<u>Sales target 1/</u>		<u>NPC forecast 2/</u>		<u>Study forecast</u>
	Peak power (MW)	Energy (GWh)	Peak power (MW)	Energy (GWh)	Peak power (MW)
1984	45.9	210.7	40	211	41.2
85	51.8	243.5	41	216	44.8
86	57.3	265.8	46	240	48.3
87	63.4	293.2	47	249	51.8
88	70.6	325.3	50	264	55.4
89	75.7	344.5	58	303	58.9
1990	81.6	365.8	62	324	62.4
91	87.3	400.6	64	343	66.0
92	93.9	434.7	67	362	69.5
93			69	392	73.0
94			72	413	76.6
95			74	437	80.1
96					83.6
97					87.2
98					90.7
99					94.3
2000					97.8
01					101.3
02					104.9

Sources: 1/ By NPC Panay Grid, 1983

2/ By NPC, 1984

表 9.2-1 土地利用適性地図からの土壌保全分類

Table 9.2-1-1 Classification of Soil Conservation Necessity from Land Suitability Map

Soil Conservation Necessity	Erosion Hazard	Class or Subclass of Suitability	km <sup>2</sup> (%)				
			Panay "B"	Faney "C"	Badbaran	Mambusao	
low	None	A	-	16.9 (3.5)	-	-	-
		BW	-	-	-	-	-
		Bs CW	-	-	-	-	-
2	Slight	X	-	-	-	-	3.4 (1.6)
		Be	-	-	-	-	9.6 (4.3)
		Cs	-	-	-	-	-
3	Moderate	Ce	-	-	-	-	3.4 (1.6)
			-	-	-	-	-
4	Severe	De	-	103.5 (20.3)	-	-	41.7 (19.3)
			-	-	-	-	-
high	Very severe Extreme	M	238.8 (100)	387.8 (76.2)	-	-	158.5 (73.2)
		Y	-	-	-	-	-
Total			238.8 (100)	509.2 (100)	258.4 (100)	216.6 (100)	



表 9.2-2 各ダム流域の土地利用区分

Table 9.2-2 Breakdown of Catchment Area as to Land Use

Land Use	Panay "B"	Panay "C"	Badbaran	Mambusao
	km <sup>2</sup> (%)	km <sup>2</sup> (%)	km <sup>2</sup> (%)	km <sup>2</sup> (%)
Lowland/Paddy rice area	-	13.6 (2.7)	43.5 (16.7)	6.8 (3.1)
Sugarcane	-	132.4 (26.0)	80.5 (31.2)	51.9 (24.0)
Pasture/Grassland	-	-	5.3 (2.1)	2.1 (1.0)
Shrub	167.4 (70.1)	272.0 (54.4)	129.1 (50.0)	147.6 (68.1)
Orchard (Coconut)	-	-	-	7.5 (3.5)
Forest	71.4 (29.9)	86.2 (16.9)	-	0.7 (0.3)
Total	238.8 (100)	509.2 (100)	258.4 (100)	216.6 (100)

表10.1-1 提案プロジェクトの計画概要

Table 10.1-1 General Features of Proposed Projects

Flood Control Project

1. River Improvement - 1st Stage

a) Design flood	:	10-year flood
b) Improvement section		
- Cogon bypass floodway	:	9.5 km
- Partial improvement of Pontevedra river (Pl partial)	:	6.1 km
- Improvement of Panay lower reach (Panitan - Congon floodway inlet)	:	6.5 km
Total	:	22.1 km
c) Major works		
- Excavation	:	3,410,000m <sup>3</sup>
- Embankment	:	570,000m <sup>3</sup>
- Revetment works	:	58,000m <sup>2</sup>
- Groin	:	4,400m
- Drainage sluices/gates	:	9 nos.
- Sluiceway structure at inlet of Pontevedra river	:	1 no.
- Fixed weir at inlet of Cogon floodway	:	1 no.
- Road and railway relocation	:	2.8 km
- Bridge	:	2 nos.
d) Construction cost (1984 base price):	:	¥589 x 10 <sup>6</sup>

2. River Improvement - 2nd Stage

a) Design flood	:	25-year flood
b) Improvement section		
- Enlargement of previously improved section (Cogon floodway - Panitan)	:	16.0 km
c) Major works		
- Excavation	:	4,708,000 m <sup>3</sup>
- Embankment	:	743,000 m <sup>3</sup>

- Revetment works	:	81,100 m <sup>2</sup>
- Groin	:	0 m
- Drainage sluices/gates	:	0 no.
- Road and railway relocation	:	0 km
- Bridge	:	2 nos.

d) Construction cost (1984 base price): Peso 440 x 10<sup>6</sup>

### 3. River Improvement - 3rd Stage

a) Design flood : 100-year flood

b) Improvement section

- Enlargement of previously improved sections (Cogon floodway - Panitan)	:	16.0 km
- Improvement of Panay Middle reach (Panitan - Badbalan confluence)	:	35.4 km
. Improvement with levees (P5, P6 & P8)	:	(14.2 km)
. Partial improvement with Levee on one bank (P3 & P7)	:	(19.0 km)
. Partial improvement of low water channel (P4)	:	(2.2 km)
- Improvement of Mambusao lower reaches (M1, M2 & M3)	:	21.2 km
- Improvement of Panay upper reach (P9)	:	8.6 km
- Improvement of Maayon river	:	20.2 km
. Improvement with levees (Y2 & Y4)	:	(18.4 km)
. Partial improvement of low water channel (Y1)	:	(1.8 km)
- Construction of a sluice gate structure at Balacuan river mouth, with partial improvement of existing Balacuan river channel	:	8.0 km
Total	:	109.4 km

c) Major works

- Excavation	:	25,515,000 m <sup>3</sup>
- Embankment	:	7,936,000 m <sup>3</sup>
- Revetment works	:	1,157,600 m <sup>2</sup>
- Groin	:	36,900 m
- Drainage sluices/gates	:	28 nos.

- Sluice gate structure at Balacuan: 1 no.  
river mouth
- Road and railway relocation : 3.8 km

d) Construction cost (1984 base price): ₱3,486 x 10<sup>6</sup>

#### 4. Polder Plan - 1st Stage Project

<u>Location</u>	<u>Protection Area</u>	<u>Length of Dyke</u>	<u>Construction Cost</u>
- Dao	1.17 km <sup>2</sup>	3.0 km	₱54.7 x 10 <sup>6</sup>
- Cuartero	0.49 km <sup>2</sup>	2.0 km	₱56.7 x 10 <sup>6</sup>
- Sigma	0.47 km <sup>2</sup>	2.8 km	₱41.8 x 10 <sup>6</sup>
- Mambusao	1.03 km <sup>2</sup>	4.9 km	₱77.6 x 10 <sup>6</sup>

#### 5. Polder Plan - 2nd Stage Project

<u>Location</u>	<u>Protection Area</u>	<u>Length of Dyke</u>	<u>Construction Cost</u>
- Maayon	0.64 km <sup>2</sup>	2.5 km	₱49.3 x 10 <sup>6</sup>
- Jamindan	0.34 km <sup>2</sup>	2.3 km	₱38.7 x 10 <sup>6</sup>
- Dumarao	0.48 km <sup>2</sup>	2.3 km	₱58.4 x 10 <sup>6</sup>

#### 6. Non-structural Measures - 1st Stage Project

##### a) Flood plain management

- Main objective area : 220 km<sup>2</sup>  
(upstream of Panitan)
- Management in integration with structural measures : 118 km<sup>2</sup>  
(downstream of Panitan)

##### b) Relocation of housings

- Objective area : Sub-areas Y1 - 0.5 km<sup>2</sup>  
Sub-area M3 - 10.4 km<sup>2</sup>  
(excl. Mambusao town)
- Estimated No. of buildings : 250 nos.

##### c) Initial capital cost

- Annual operation cost : Peso 52 x 10<sup>6</sup>
- Annual operation cost : Peso 4.0 x 10<sup>6</sup>

#### 7. Flood Forecasting/Warning System - 1st Stage Project

##### a) Proposed facility

- Staff stream gage : 10 gages
- Telemeter rain gage : 4 stations
- Telemeter stream gage : 5 stations

- Repeater station : 1 station (Panitan)
- Central receiving station : 1 station (Roxas)
- b) Installation cost : Peso 84 x 10<sup>6</sup>
- Annual operating cost : Peso 4.2 x 10<sup>6</sup>

Multipurpose Dam Project

Panay B Dam:

a) Hydrology

- Catchment area : 239 km<sup>2</sup>
- Average runoff : 14.3 m<sup>3</sup>/sec
- Flood discharges :

<u>Return Period</u>	<u>Inflow</u>	<u>Outflow</u>
100-year	2,420 m <sup>3</sup> /sec	1,210 m <sup>3</sup> /sec
25-year	1,250 m <sup>3</sup> /sec	625 m <sup>3</sup> /sec

b) Reservoir

- Gross storage : 96.0 x 10<sup>6</sup> m<sup>3</sup>
- Effective storage : 64.3 x 10<sup>6</sup> m<sup>3</sup>
  - Flood control : (33.8 x 10<sup>6</sup> m<sup>3</sup>)
  - Hydropower : (30.5 x 10<sup>6</sup> m<sup>3</sup>)
- Normal high water level : El. 65.0 m
- Surge water level (100-year flood control) : El. 71.3 m

c) Dam

- Type : Concrete gravity dam
- Crest El. : El. 77.4 m
- Crest length : 160 m
- Dam Height : 52.4 m
- Dam volume : 93 x 10<sup>3</sup> m<sup>3</sup>

d) Generating facilities

- Max. plant discharge : 27.2 m<sup>3</sup>/sec
- Head, max. static : 35.0 m
- Head, rated : 31.7 m
- Installed capacity : 7.1 MW
- Annual energy output : 31.4 GWh

e) Power transmission facilities

- Voltage : 69 kV
- Transmission line length : 45 km

- Receiving substation : Panitan substation (Existing)
- f) Construction cost (1988 base price) : P471.2 x 10<sup>6</sup>

### Irrigation Project

#### 1. Panitan - Panay Scheme

##### a) General data:

- Location : Panitan - Panay area
- Net irrigation area : 3,250 ha
- Water source : Panay river
- Diversion requirement : 4.75 m<sup>3</sup>/sec

##### b) Intake/Headreach:

- Location of intake : 1 km u/s of Panitan
- Type of intake : By pumping
- Pump capacity : 284.4 m<sup>3</sup>/min
- Headreach length (2 systems) : 1.8 km
- Type of headreach : Concrete-lined

##### c) Main canal:

- Type : Trapezoidal earth canal
- Total length : 17.8 km

##### d) Lateral canal:

- Type : Trapezoidal earth canal
- Total length : 39.6 km

##### e) Drainage facilities:

- Main drain : 13.0 km
- Collector drain : 17.7 km

##### f) Construction cost (1984 base price): P182.3 x 10<sup>6</sup>

#### 2. Mambusao Scheme

##### a) General data:

- Location : Mambusao downstream reaches
- Net irrigation area : 2,145 ha
- (Improvement of existing area : 1,640 ha)
- (Extension area : 505 ha)
- Water source : Mambusao river
- Diversion requirement : 2.6 m<sup>3</sup>/sec

- b) Intake:
- Location : 6 km u/s of Mambusao
  - Type of intake : By gravity
  - Design discharge :  $2.6 \text{ m}^3/\text{sec}$
- c) Main canal:
- Type : Trapezoidal earth canal
  - Length : 14.6 km (rehabilitation)
- d) Lateral canal:
- Type : Trapezoidal earth canal
  - Length : 33.2 km (rehabilitation)  
5.5 km (new const.)
- e) Drainage facility:
- Drain : 25 km
  - Rehabilitation of creeks : 11 km
- f) Construction cost (1984 base price):  $\text{P}79 \times 10^6$

### Water Supply Project

#### ROX-WD Water Supply Project:

- a) General data:
- Supply area : Roxas City and surrounding area
  - Water source : Main Panay river
  - Water abstraction rate :  $3.0 \text{ m}^3/\text{sec}$  incl. water for existing irrigation areas and surplus supply capacity of  $1.0 \text{ m}^3/\text{sec}$
  - Water supply to ROX-WD :  $7,450 \text{ m}^3/\text{day}$
- b) Proposed facilities/works:
- Shortcut channel between Main Panay river and Lower Panay river : 344 m
  - Intake gate at shortcut channel inlet: 2 m wide x 2 m high x 2 nos.
  - Dredging of the Lower Panay riverbed :  $20 \text{ km} (85 \times 10^3 \text{ m}^3)$
  - Construction of a new pumping station:  $7,450 \text{ m}^3/\text{day}$
  - Installation of a new conveyance pump: 300 mm dia., 1.0 km
  - Construction of a tidal gate : 5 m wide x 4.5 m high x 3 nos.
- c) Construction cost (1984 base price) :  $\text{P}56 \times 10^6$

表10.3-1 河川改修の工事費用概算

Table 10.3-1 Summary of Construction Cost of  
River Improvement Works  
(1984 Base Price)

(Unit: ¥ x 10<sup>6</sup>)

Work Item	First Stage	Second Stage	Third Stage
1. Construction Works			
(1) Preparatory Works <sup>/1</sup>	28.9	20.2	167.5
(2) Excavations	152.4	209.2	1,131.5
(3) Embankment	8.7	11.4	121.4
(4) Revetment and Slope Protection	55.9	61.5	872.1
(5) Groins	5.3	0.0	44.3
(6) Drainage Gates	25.2	0.0	58.9
(7) Diversion Weirs	120.1	0.0	0.0
(8) Road and Bridge Relocations	45.5	6.8	165.3
(9) Miscellaneous Works	22.1	53.5	267.6
Sub-total	<u>464.1</u>	<u>362.5</u>	<u>2,828.6</u>
2. Land Acquisition and Resettlement	<u>31.5</u>	<u>7.7</u>	<u>105.4</u>
3. Engineering and Administration <sup>/2</sup>	<u>39.7</u>	<u>29.6</u>	<u>234.7</u>
4. Physical Contingency <sup>/3</sup>	<u>53.5</u>	<u>40.0</u>	<u>317.0</u>
Grand Total	<u>588.8</u>	<u>439.8</u>	<u>3,485.7</u>

Notes: /1 7% of main civil works cost

/2 8% of (1 + 2)

/3 10% of (1 + 2 + 3)



表10.3-2 パナイBダムの工事費

Table 10.3-2 Construction Cost of Panay B Dam

(Unit: ₱x10<sup>6</sup>)

Work Item	Foreign Portion	Local Portion	Total
A. Preparatory Works			
(1) Road construction	0	17.01	17.01
(2) Work shops, offices and etc. <sup>1/</sup>	8.86	6.92	15.78
Sub-total of A.	8.86	23.93	32.79
B. Civil Works			
(1) River diversion works	11.56	8.78	20.34
(2) Dam and spillway	88.04	68.89	156.93
(3) Power station	11.12	8.82	19.94
Sub-total of B.	110.72	86.49	197.21
C. Metal Works	29.63	2.96	32.59
D. Electrical Works	87.76	25.61	113.37
E. Land Acquisition and Compensation	0	14.72	14.72
F. Government Administration <sup>2/</sup>	0	18.80	18.80
G. Engineering Service <sup>3/</sup>	15.04	3.76	18.80
H. Physical Contingency <sup>4/</sup>	25.23	17.69	42.92
<u>Grand Total</u>	<u>277.24</u>	<u>193.96</u>	<u>471.20</u>

Note: <sup>1/</sup>; (2) = 8% of item B  
<sup>2/</sup>; F = 5% of item (A+B+C+D)  
<sup>3/</sup>; G = 5% of item (A+B+C+D)  
<sup>4/</sup>; H = 10% of item A to G

表10.3-3 各輪中計画工事費 (第1期プロジェクト)

Table 10.3-3 Construction Cost of Each Forder Plan- 1st Stage Project

Item	Unit	Unit Price (P)	Dao		Sigma		Mambusao		Cuartero	
			Q'ty	Amount (# x 10 <sup>6</sup> )	Q'ty	Amount (# x 10 <sup>6</sup> )	Q'ty	Amount (# x 10 <sup>6</sup> )	Q'ty	Amount (# x 10 <sup>6</sup> )
<b>1. Construction Works</b>										
Preparatory works <sup>1/</sup>				2.92	2.16		4.10		3.07	
Dike embankment	m <sup>3</sup>	51.8	233,850	12.11	188,000	9.74	243,050	12.59	294,000	15.23
Concrete Revetment	m <sup>2</sup>	600.0	18,360	11.02	11,300	6.78	34,680	20.81	24,600	14.76
Sod facing	m <sup>2</sup>	56.0	62,280	3.49	63,300	3.54	51,840	2.90	56,700	3.18
Gravel pavement for road	m	750.0	0	0	0	0	0	0	0	0
Asphalt pavement for road	m	3,600.0	0	0	500	1.80	800	2.88	0	0
Drainage facilities in town	ha	54,000.0	27	1.46	11	0.59	39	2.11	21	1.13
Drainage facilities in paddy	ha	18,000.0	90	1.62	36	0.65	64	1.15	28	0.50
Pumping station	L.S			10.00		6.30		13.40		6.90
Others <sup>2/</sup>				1.99		1.47		2.79		2.09
Total of 1				44.61		33.03		62.73		46.86
<b>2. Compensation</b>										
Residential buildings	nos.	20,400.0	33	0.67	40	0.82	55	1.12	0	0
Non-residential buildings	nos.	204,300.0	0	0	4	0.82	2	0.41	0	0
Total of 2				0.67		1.64		1.53		0
<b>3. Government Administration<sup>3/</sup></b>										
Government Administration				2.23		1.65		3.14		2.34
<b>4. Engineering Service<sup>4/</sup></b>										
Engineering Service				2.23		1.65		3.14		2.34
<b>5. Physical Contingency<sup>5/</sup></b>										
Physical Contingency				4.97		3.80		7.05		5.15
Grand Total				54.71		41.77		77.59		56.69

Notes: <sup>1/</sup>: 7% of construction works excluding preparatory works.

<sup>2/</sup>: 5% of construction works excluding preparatory works and others.

<sup>3/</sup>: 5% of construction works

<sup>4/</sup>: 5% of construction works

<sup>5/</sup>: 10% of (1 + 2 + 3 + 4)

表10.3-4 各輪中計画の工事費 (第2期プロジェクト)

Table 10.3-4 Construction Cost of Each Polder Plan - 2nd Stage Project

Item	Unit	Unit Price (P)	Mayon		Jamindan		Dumano	
			Q'ty	Amount (P x 10 <sup>6</sup> )	Q'ty	Amount (P x 10 <sup>6</sup> )	Q'ty	Amount (P x 10 <sup>6</sup> )
<b>1. Construction Works</b>								
Preparatory works <sup>1/</sup>				2.63		2.05		3.03
Dike embankment	m <sup>3</sup>	51.8	227,850	11.80	211,050	10.93	221,950	11.50
Concrete Revetment	m <sup>2</sup>	600.0	19,800	11.88	9,720	5.83	24,750	14.85
Sod facing	m <sup>2</sup>	56.0	59,340	3.32	61,320	3.43	51,150	2.86
Asphalt pavement for road	m	3,600.0	0	0	0	0	1,100	3.96
Drainage facilities in town	ha	54,000.0	8	0.43	18	0.97	21	1.13
Drainage facilities in paddy	ha	18,000.0	56	1.01	16	0.29	27	0.49
Pumping station	L.S			7.30		6.40		6.50
Others <sup>2/</sup>				1.79		1.39		2.06
Total of 1				40.16		31.29		46.38
<b>2. Compensation</b>								
Residential buildings	nos.	20,400.0	30	0.61	35	0.72	50	1.02
Non-residential buildings	nos.	204,300.0	0	0	0	0	5	1.02
Total of 2				0.61		0.72		2.04
<b>3. Government Administration<sup>3/</sup></b>								
				2.01		1.57		2.32
<b>4. Engineering Service<sup>4/</sup></b>								
				2.01		1.57		2.32
<b>5. Physical Contingency<sup>5/</sup></b>								
				4.48		3.52		5.31
Grand Total				49.27		38.67		58.37

Notes: 1/; 7% of construction works excluding preparatory works.  
 2/; 5% of construction works excluding preparatory works and others.  
 3/; 5% of construction works  
 4/; 5% of construction works  
 5/; 10% of (1 + 2 + 3 + 4)

表10.3-5 非施設の対象の費用見積り

Table 10.3-5 Estimated Cost of Non-structural Measures

Item	Q'ty	Amount (10 <sup>6</sup> Peso)
1. Flood Plain Management:		
(1) Annual operating cost	338 km <sup>2</sup>	<u>4.0</u>
(2) Initial cost	338 km <sup>2</sup>	<u>28.7</u>
2. Relocation of Housings:		
(1) Resettlement cost	L.S.	18.1
(2) Land procurement cost	L.S.	4.5
Total		<u>22.6</u>

Notes: (1) See Table 5.5-1 for units costs assumed

(2) Relocation of housings:

	<u>Sub-area Y1</u>	<u>Sub-area N3</u>
Residential	21 nos.	0
Non-residential	220 nos.	12 nos.

(These are estimated on 1:10,000 map)

表10.3-6 バンタン～パナイ灌漑プロジェクトの工事費

Table 10.3-6 Construction Cost of Panitan - Panay Irrigation Project

Item	Total	(Unit: ₱ x 10 <sup>6</sup> )	
		Foreign Currency	Local Currency
1. Direct Construction Cost			
1.1 Preparatory	5.62	1.12	4.50
1.2 Pump stations	35.04	27.32	7.72
1.3 Irrigation facilities	49.40	23.90	25.50
1.4 Drainage facilities	15.79	9.36	6.43
1.5 On-farm development	12.23	7.15	5.08
Sub-total	<u>118.08</u>	<u>68.85</u>	<u>49.23</u>
2. O & M Facilities	<u>10.01</u>	<u>5.85</u>	<u>4.16</u>
3. Land Acquisition	<u>1.33</u>	<u>0</u>	<u>1.33</u>
4. Engineering Services	<u>23.62</u>	<u>18.90</u>	<u>4.72</u>
5. Administration Cost of Executive Agency	<u>5.90</u>	<u>0</u>	<u>5.90</u>
6. Physical Contingency	<u>23.85</u>	<u>14.04</u>	<u>9.81</u>
<b>Total</b>	<b>182.79</b>	<b>107.64</b>	<b>75.15</b>

表10.3-7. マンブサオ灌漑プロジェクトの工事費

Table 10.3-7 Construction Cost of Mambusao Irrigation Project

(Unit: ¥ x 10<sup>6</sup>)

Item	Total	Foreign Currency	Local Currency
1. Direct Construction Cost	2.32	0.47	1.85
1.1 Preparatory works	2.32	0.47	1.85
1.2 Intake facility	0.28	0.25	0.13
1.3 Irrigation facilities	27.51	12.53	14.98
1.4 Drainage facilities	10.40	6.21	4.19
1.5 On-farm development	8.01	4.70	3.31
Sub-total	<u>48.62</u>	<u>24.16</u>	<u>24.46</u>
2. O & M Facilities	<u>7.76</u>	<u>5.63</u>	<u>2.13</u>
3. Land Acquisition	<u>0.52</u>	-	<u>0.52</u>
4. Engineering Service	<u>9.72</u>	<u>7.78</u>	<u>1.94</u>
5. Administration Cost of Executive Agency	<u>2.43</u>	-	<u>2.43</u>
6. Physical Contingency	<u>10.35</u>	<u>5.63</u>	<u>4.72</u>
Total	79.40	43.20	39.20

表10.3-8 提案されたロルス市水道地区改良計画の工事費

Table 10.3-8 Construction Cost of Proposed ROX-WD Improvement Plan

(Unit: ₪ x 10<sup>3</sup>)

No.	Item	Amount		Total
		F/C	L/C	
1.	Preparatory Work (7% of Item No.3)	<u>2,086</u>	<u>992</u>	<u>3,078</u>
2.	Compensation	-	<u>48</u>	<u>48</u>
3.	Main Work			
3.1	Ground sill	1,479	745	2,224
3.2	Approach channel	974	691	1,665
3.3	Sluice conduit	3,609	1,823	5,432
3.4	Dredging basin	488	448	936
3.5	Connecting channel	852	540	1,392
3.6	Riverbed excavation	1,683	1,054	2,737
3.7	Tidal gate on Lower Panay river	7,097	2,276	9,373
3.8	Tidal gate on streams (2 sites)	4,896	1,520	6,416
3.9	Pumping station (7,450 m <sup>3</sup> /day)	6,156	4,104	10,260
3.10	Pipeline (φ 300, L=1,400 m)	1,142	298	1,440
3.11	Miscellaneous (5% of Item Nos.3.1 to 3.9)	1,419	675	2,094
	Sub-total of Item No.3	<u>29,795</u>	<u>14,174</u>	<u>43,969</u>
4.	Engineering & Administration (8% of Item Nos.1 to 3)	<u>2,550</u>	<u>1,217</u>	<u>3,767</u>
5.	Physical Contingency (10% of Item Nos.1 to 4)	<u>3,443</u>	<u>1,643</u>	<u>5,086</u>
	Ground Total	37,874	18,074	55,948

表10.3-9 提案されたプロジェクトの経済評価

Table 10.3-9 Economic Evaluation of Proposed Projects

Project	Project Cost (P x 10 <sup>6</sup> )	Present Value <sup>/1</sup> (P x 10 <sup>6</sup> )			B/C	EIRR
		Cost	Benefit	NPV		
<b>Flood Control Project</b>						
<b>(a) River improvement</b>						
- 1st stage work	589	285	362	77	1.3	9.4
- 2nd stage work <sup>/2</sup>	440	56	94	38	1.7	9.8
- 3rd stage work <sup>/2</sup>	3,486	197	663	466	3.4	15.2
<b>(b) Polder</b>						
- 1st stage work						
. Dao	55	56	102	46	1.8	12.7
. Cuartero	57	59	236	177	4.0	25.7
. Sigma	42	43	61	18	1.4	10.5
. Mambusao	78	80	130	50	1.6	11.6
- 2nd stage work <sup>/2</sup>						
. Maayon	49	34	39	5	1.1	9.3
. Jamindan	39	27	32	5	1.2	9.2
. Dumarao	58	13	13	0	1.0	8.1
<b>(c) Multipurpose dam</b>						
- Panay B dam	471	346	476	130	1.4	11.2
<b>(d) Non-structural measures<sup>/3</sup></b>						
	52	( 81)	( 96)	( 15)	(1.2)	(9.6)
<b>(e) Flood forecasting/warning system<sup>/3</sup></b>						
	84	(83)	(43)	(-40)	(0.5)	(4.5)
<b>(f) Overall<sup>/4</sup></b>						
- 1st stage projects	1,376	966	1,435	469	1.5	11.4
- 2nd stage projects	586	130	178	48	1.4	9.8
<b>Irrigation Development Project</b>						
- Panitan-Panay Project	183	170	248	78	1.5	11.7
- Mambusao Project	79	69	112	43	1.6	12.3
<b>Roxas City Water Supply Project</b>						
	56	67	100	33	1.5	16.9
<b>(Reference)</b>						
1st stage river impr. + Panitan-Panay irrigation	772	362	508	146	1.4	10.1

- Notes: <sup>/1</sup> Discount rate of 8% p.a., 1984 economic price.  
<sup>/2</sup> Implementation schedule as per shown in Fig. 10.2-1.  
<sup>/3</sup> Benefit estimate partly duplicated with those assessed for structural measures. These works are proposed for implementation irrespective of economic merits. EIRR value just for reference.  
<sup>/4</sup> Overall assessment by stage. Duplication of benefits in (d) and (e) was eliminated.



表10.3-10 感度分析結果

Table 10.3-10 Results of Sensitivity Analysis

Project	Standard Value	Sensitivity Analysis	
		Cost 20% up	Benefit 20% down
(EIRR %)			
Flood Control Project			
(a) River improvement			
- 1st stage work	9.4	8.3	8.1
- 2nd stage work	9.8	9.1	9.0
- 3rd stage work	15.2	13.8	13.5
(b) Polder			
- 1st stage work			
. Dao	12.7	11.0	10.6
. Cuartero	25.7	21.5	20.7
. Sigma	10.5	9.1	8.8
. Mambusao	11.6	10.0	9.7
- 2nd stage work			
. Maayon	9.3	7.4	7.0
. Jamindan	9.2	7.9	7.7
. Dumarao	8.1	6.4	6.1
(c) Multipurpose dam			
- Panay B dam (1st Stage)	11.2	9.4	9.0
(d) Overall <sup>/1</sup>			
- 1st stage projects	11.4	9.9	9.5
- 2nd stage projects	9.8	8.7	8.5
Irrigation Development Project			
- Panitan-Panay Project	11.7	9.8	9.4
- Mambusao Project	12.3	10.6	10.2
Roxas City Water Supply Project	16.9	12.4	11.5
(Reference)			
1st stage river impr. + Panitan-Panay irrigation	10.1	8.9	8.7

Note: <sup>/1</sup> Incl. non-structural measures and flood forecasting/warning system.

表 11.1-1 洪水氾濫地区における将来土地利用及び開発規制試案

Table 11.1 Tentative Plan of Future Land Uses and Developments in Flood Prone Area (1)

	AREA - 1	AREA - 2	AREA - 3
Item	where flood protection work (structural measure) is provided or scheduled to be provided under short-term programs.	where no protection work is proposed or the work will be implemented only in distant future.	Area to be procured for river improvement work in future, i.e. area confined by levees to form a future river channel.
Land Use	<p><u>Policy</u></p> <p>No specific regulation of land uses. However, inhabitants should be informed of remaining flood risks which are not removed by the protection works provided in the area.</p> <p><u>Guideline</u></p> <p><u>Agriculture:</u></p> <ul style="list-style-type: none"> <li>- uses for labour intensive and value-added agricultural productions</li> <li>- uses for value-added aquacultural productions such as fishponds</li> </ul> <p><u>Town proper:</u></p> <ul style="list-style-type: none"> <li>- promotion of intensive commercial and industrial uses</li> <li>- positive uses for public facilities such as public buildings, schools, hospitals, etc.</li> <li>- uses for residential buildings</li> <li>- promotion of orderly urbanization development</li> </ul>	<p><u>Policy</u></p> <p>Present land uses can be continued with some intensification within limits set by people's acceptance of loss burden.</p> <p><u>Guideline</u></p> <p><u>Agriculture:</u></p> <ul style="list-style-type: none"> <li>- uses for labour-saving agricultural productions</li> <li>- change of cropping schedule<sup>1/2</sup> in heavily damageable areas</li> <li>- no extensive land development (such as new irrigation), unless it is clarified not to receive excessive flood damage</li> <li>- reinforcement of fishpond dykes</li> </ul> <p><u>Town proper:</u></p> <ul style="list-style-type: none"> <li>- restricted expansion of existing towns</li> <li>- encouragement of land uses in high level areas</li> </ul> <p><u>Other uses:</u></p> <ul style="list-style-type: none"> <li>- uses of lands for temporarily used facilities such as recreation, sports and fiesta facilities</li> <li>- positive uses for water storage and that they will have flood retarding function</li> <li>- positive provision of evacuation area on highlands</li> </ul>	<p><u>Policy</u></p> <p>In principle, present land uses will be allowed until the lands are procured for river improvement work. People should be informed that the area is defined as essential floodway of design flood.</p> <p><u>Guideline</u></p> <p><u>Agriculture:</u></p> <ul style="list-style-type: none"> <li>- restriction to present land use</li> <li>- No new reclamation</li> </ul> <p><u>Town proper:</u></p> <ul style="list-style-type: none"> <li>- restriction of further expanding uses</li> </ul> <p><u>Other uses:</u></p> <ul style="list-style-type: none"> <li>- only open land uses to be allowed</li> <li>- prohibition of excessive land fill/deposits and permanent obstructions</li> </ul>

Notes: The above shows preliminary guidelines for future land uses and development activities. Details of the implementation methods. (incl. legislation, planning and enforcing organizations, public information, etc.) should be examined in a separated study.

<sup>1/2</sup> For example, plantation of Mung beans instead of cropping of the 2nd paddy (See Appendix IV for details).

Table 11.1 Tentative Plan of Future Land Uses and Developments in Flood Prone Area (2)

	AREA - 1	AREA - 2	AREA - 3
Item	where flood protection work (structural measure) is provided or scheduled to be provided under short-term programs.	where no protection work is proposed or the work will be implemented only in distant future.	Area to be procured for river improvement work in future, i.e. area confined by levees to form a future river channel.
Building	<p><u>Policy</u></p> <p>No specific restriction of building development.</p> <p><u>Guideline</u></p> <ul style="list-style-type: none"> <li>- encouragement of non-combustible and durable buildings</li> <li>- construction of residential areas according to land use zoning</li> <li>- construction of buildings on land fill or elevated floor buildings in areas where only low-level protection work is provided.</li> </ul>	<p><u>Policy</u></p> <p>No positive enforcement of restriction. However, people should be educated to make them incentive to reduce flood damages on their buildings and properties.</p> <p><u>Guideline</u></p> <ul style="list-style-type: none"> <li>- guidance to people to have their new buildings in flood-free area or on elevated lands, or otherwise to construct elevated floor buildings</li> <li>- relocation of housings in areas which are exposed to danger to life</li> <li>- preparedness for emergency (stock of foodstuffs, rescue boat, etc.)</li> </ul>	<p><u>Policy</u></p> <p>Any new settlement/building development should be discouraged through dissemination of flood risks to people.</p>
Public Facilities/ Government Projects	<p><u>Policy</u></p> <p>No specific constraints in implementing facilities and/or projects. However, the plan and design should take into account the remaining risks of occurrence of larger floods than the design one.</p> <p><u>Guideline</u></p> <ul style="list-style-type: none"> <li>- promotion of irrigation, fishpond and other productive facilities</li> <li>- positive provision of infra-structures for amplification of social capitals</li> </ul>	<p><u>Policy</u></p> <p>Restricted development in this area. All facilities should be built in due consideration of present/future flood conditions in the area.</p> <p><u>Guideline</u></p> <ul style="list-style-type: none"> <li>- no implementation of large scale projects, unless they are proven to be free from flood damage</li> <li>- construction of flood-free structures (e.g. construction of roads above flood water level with proper drainage facilities)</li> </ul>	<p><u>Policy</u></p> <p>In principle, no new public facilities will be added and no government project proposed in this area. Bridges and other river facilities are planned in consideration of future river improvement works.</p>

Notes: The above shows preliminary guidelines for future land uses and development activities. Details of the implementation methods. (incl. legislation, planning and enforcing organizations, public information, etc.) should be examined in a separated study.

1. For example, plantation of Mung beans instead of cropping of the 2nd paddy (See Appendix IV for details).

42

43

44

45

FIGURES

FOR

MAIN REPORT

主報告書の付図

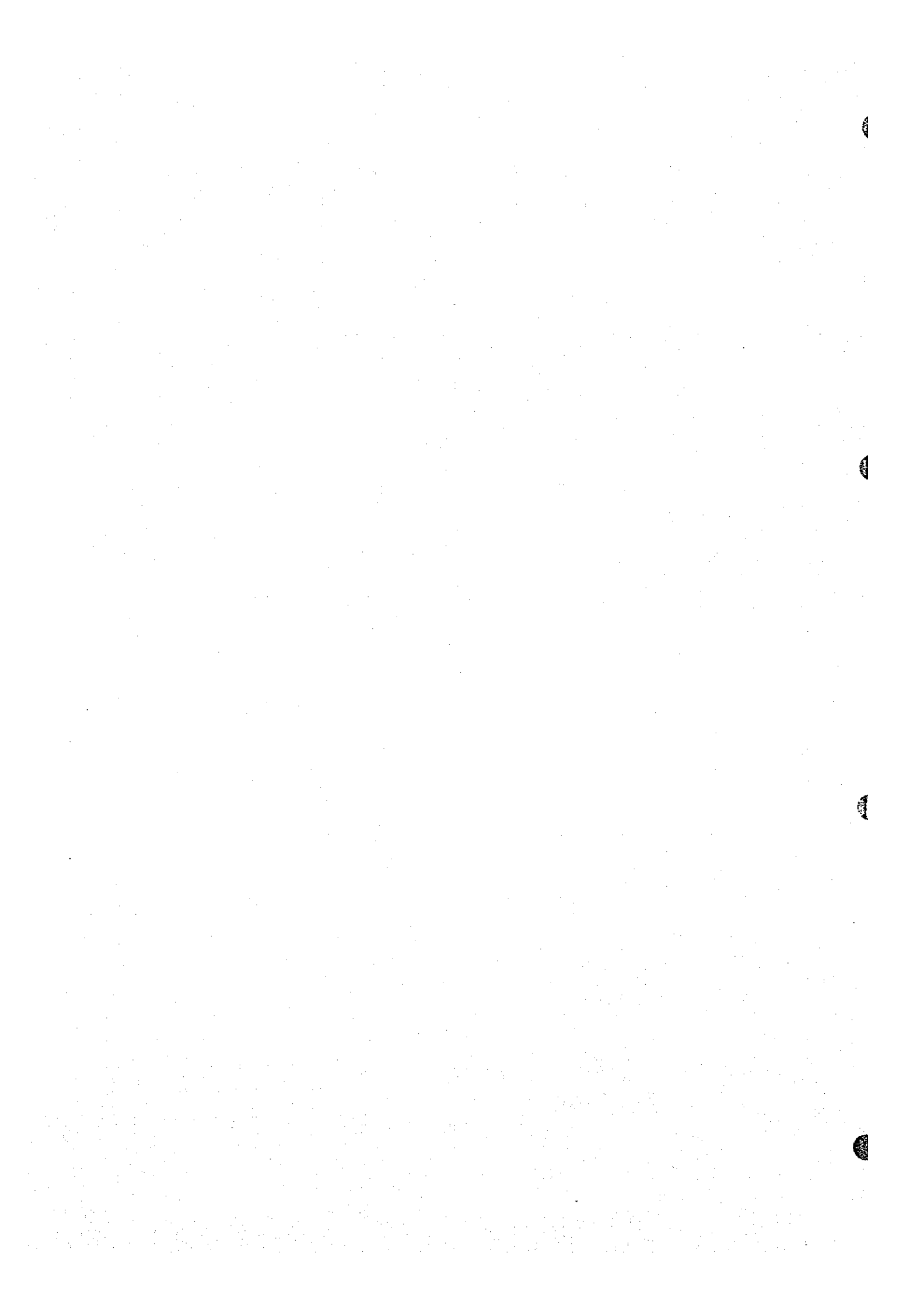





图 3.1-1 地域全体图  
Fig. 3.1-1 GENERAL BASIN MAP





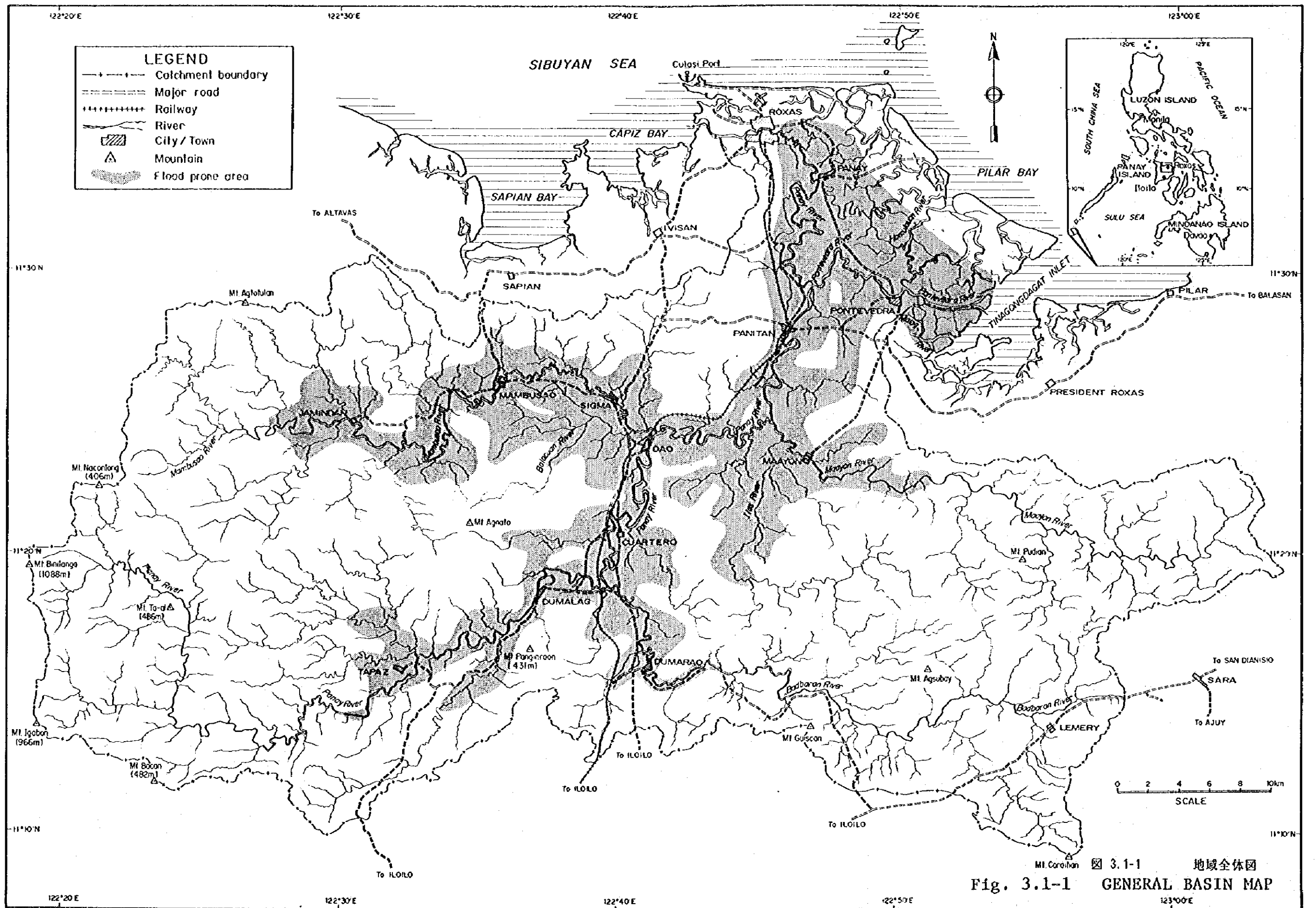
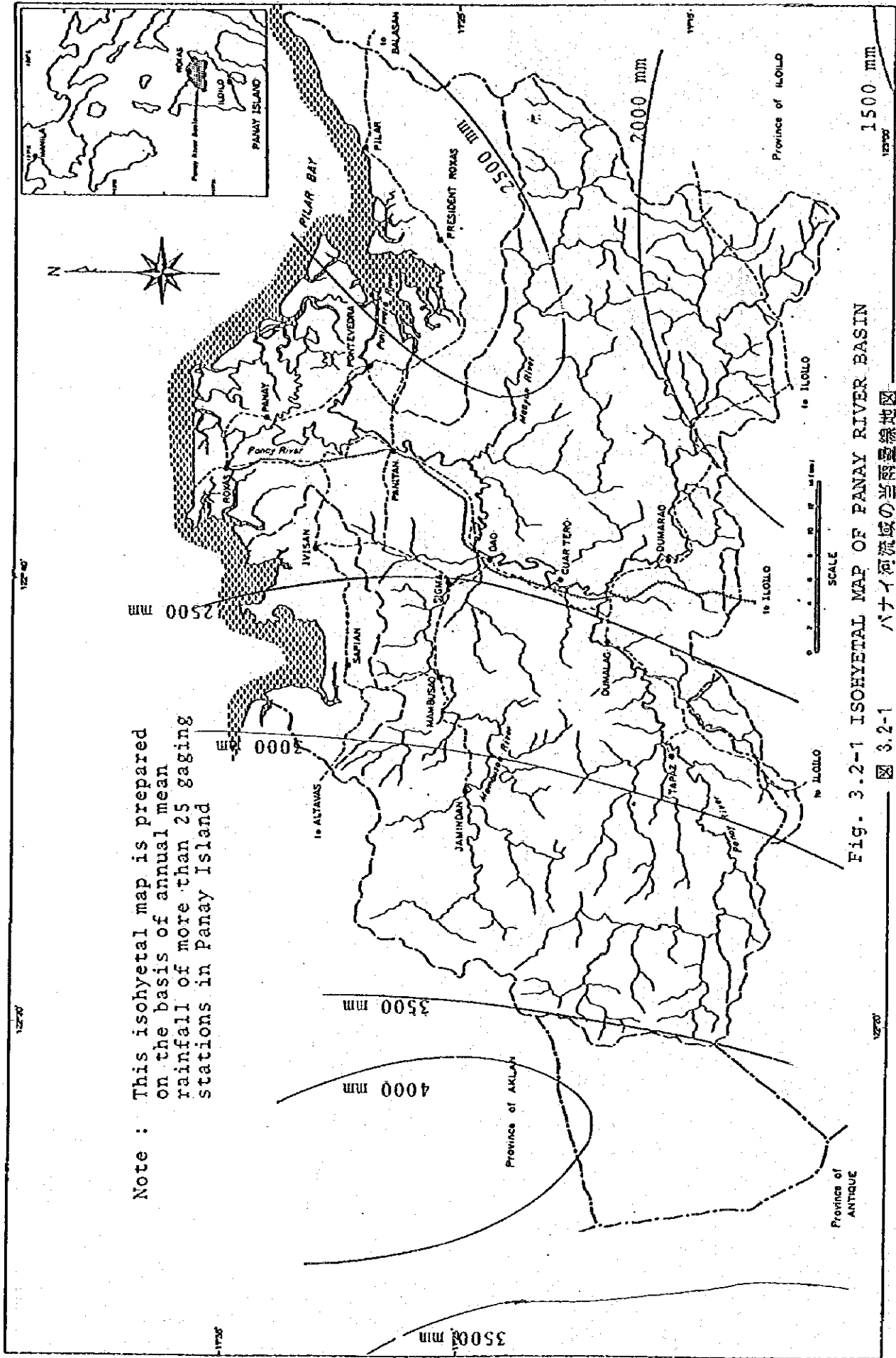

Note : This isohyetal map is prepared on the basis of annual mean rainfall of more than 25 gaging stations in Panay Island

Fig. 3.2-1 ISOHYETAL MAP OF PANAY RIVER BASIN

図 3.2-1 パナイ河流域の当雨量線地図

1500 mm

1250'

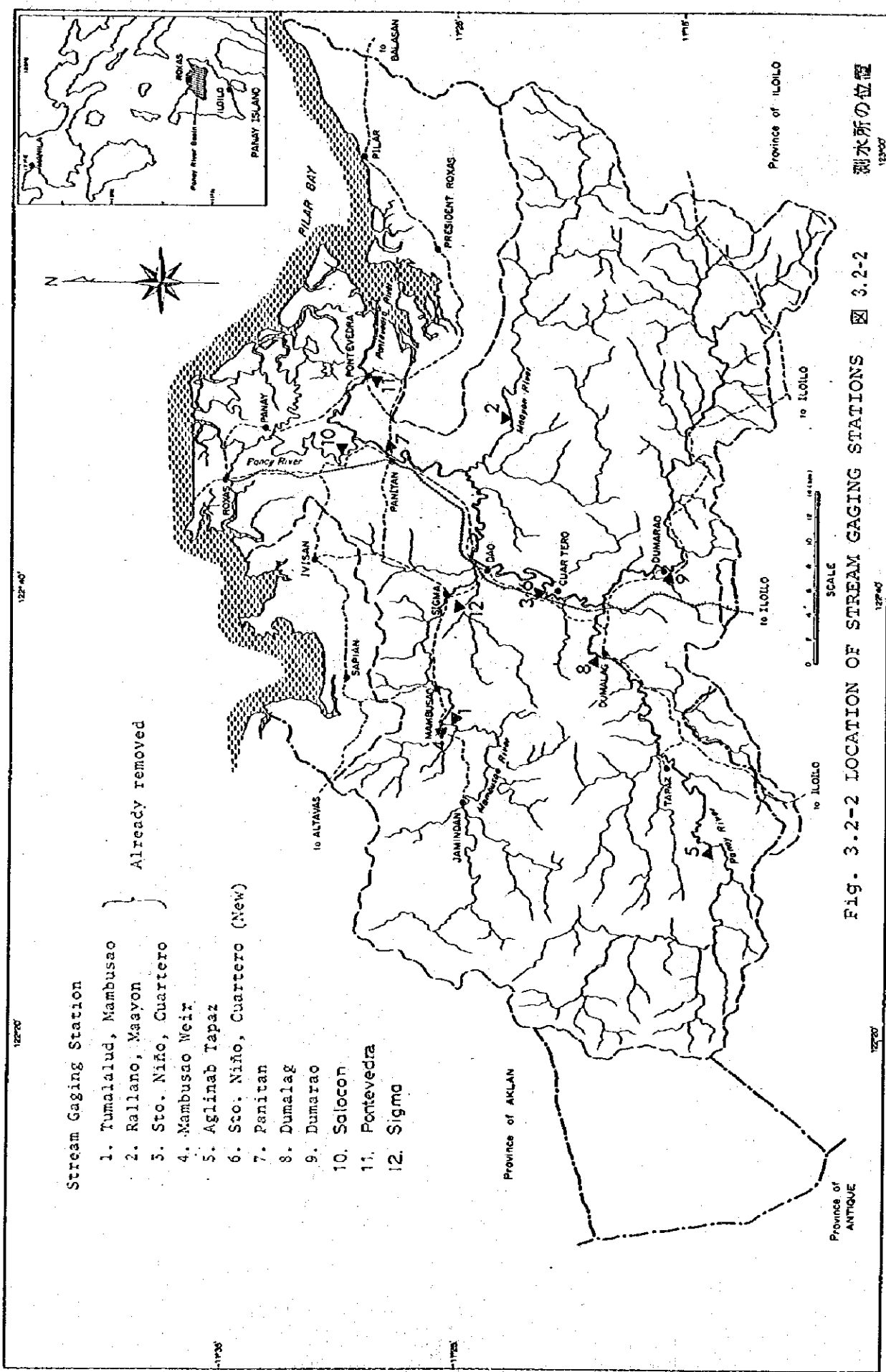

Stream Gaging Station

- 1. Tumulalud, Mambusao
- 2. Rallano, Masyon
- 3. Sto. Niño, Cuartero
- 4. Mambusao Weir
- 5. Aglinab Tapaz
- 6. Sto. Niño, Cuartero (New)
- 7. Panitan
- 8. Dumalag
- 9. Dumarao
- 10. Salocon
- 11. Pontevedra
- 12. Sigma

} Already removed

Fig. 3.2-2 LOCATION OF STREAM GAGING STATIONS 図 3.2-2

測水所の位置

Province of ANTIQUE

Province of ILOILO

Province of AKLAN

SCALE  
0 1 2 3 4 5 6 7 8 9 10 (KILOMETERS)



122° 40'

122° 40'

12° 20'

12° 20'

Fig. 3.2-3 REGIONAL GEOLOGICAL MAP OF THE PROJECT AREA

図 3.2-3 パナイ河流域の地質分布図





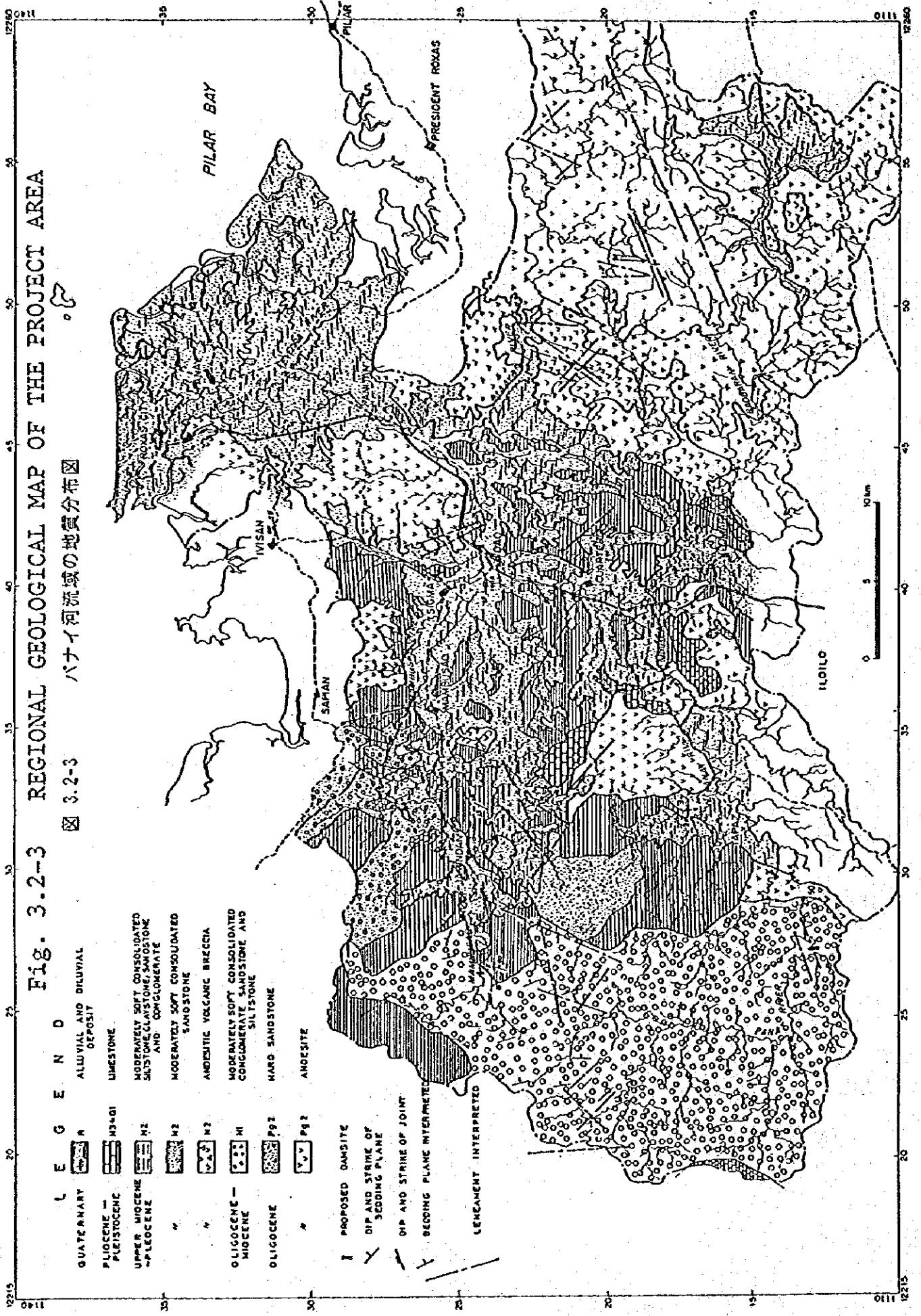

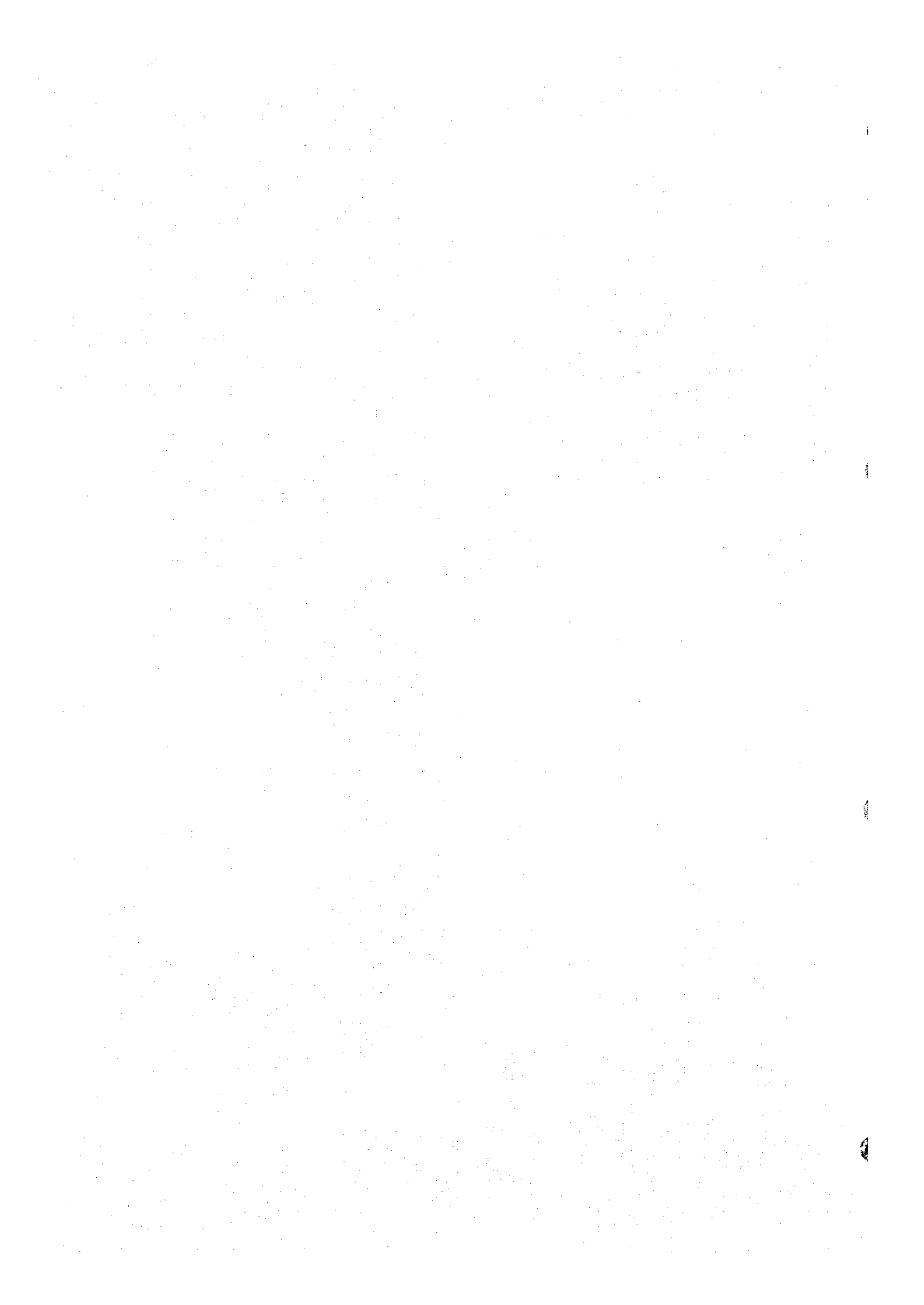

- L E G E N D**
- QUATERNARY - A ALLUVIAL AND DILUVIAL DEPOSIT
  - PLIOCENE - PLEISTOCENE - M3+01 LIMESTONE
  - UPPER MIOCENE - PLEOCENE - M2 MODERATELY SOFT CONSOLIDATED SILTSTONE, CLAYSTONE, SANDSTONE AND CONGLOMERATE
  - " " M2 MODERATELY SOFT CONSOLIDATED SANDSTONE
  - " " M2 ANDENITIC VOLCANIC BRECCIA
  - OLIGOCENE - MIOCENE - M1 MODERATELY SOFT CONSOLIDATED CONGLOMERATE SANDSTONE AND SILTSTONE
  - OLIGOCENE - P92 HARD SANDSTONE
  - " " P92 ANDESITE

- I PROPOSED DAMSITE
- Y DIP AND STRIKE OF SEDDING PLANE
- - - DIP AND STRIKE OF JOINT
- - - BEDDING PLANE INTERPRETED
- - - LENCAMENT INTERPRETED







LEGEND	
Symbol	Land Use
	R Lowland/Paddy field
	S Sugercane
	G Pasture/Grass land
	C Coconuts
	B Shrub
	F forest
	P Fish pond
	M Marshes/ Swamp area
	H Built-up area

Remarks: S/G,R means that sugarcane is dominant the area, followed by grassland and rice area.



図 3.3-1 パナイ河流域の現況土地利用  
Fig.3.3-1 PRESENT LAND USE IN THE PANAY



図 3.3-2 洪水による冠水地域図  
 Fig.3.3-2 FLOOD VULNERABLE AREA



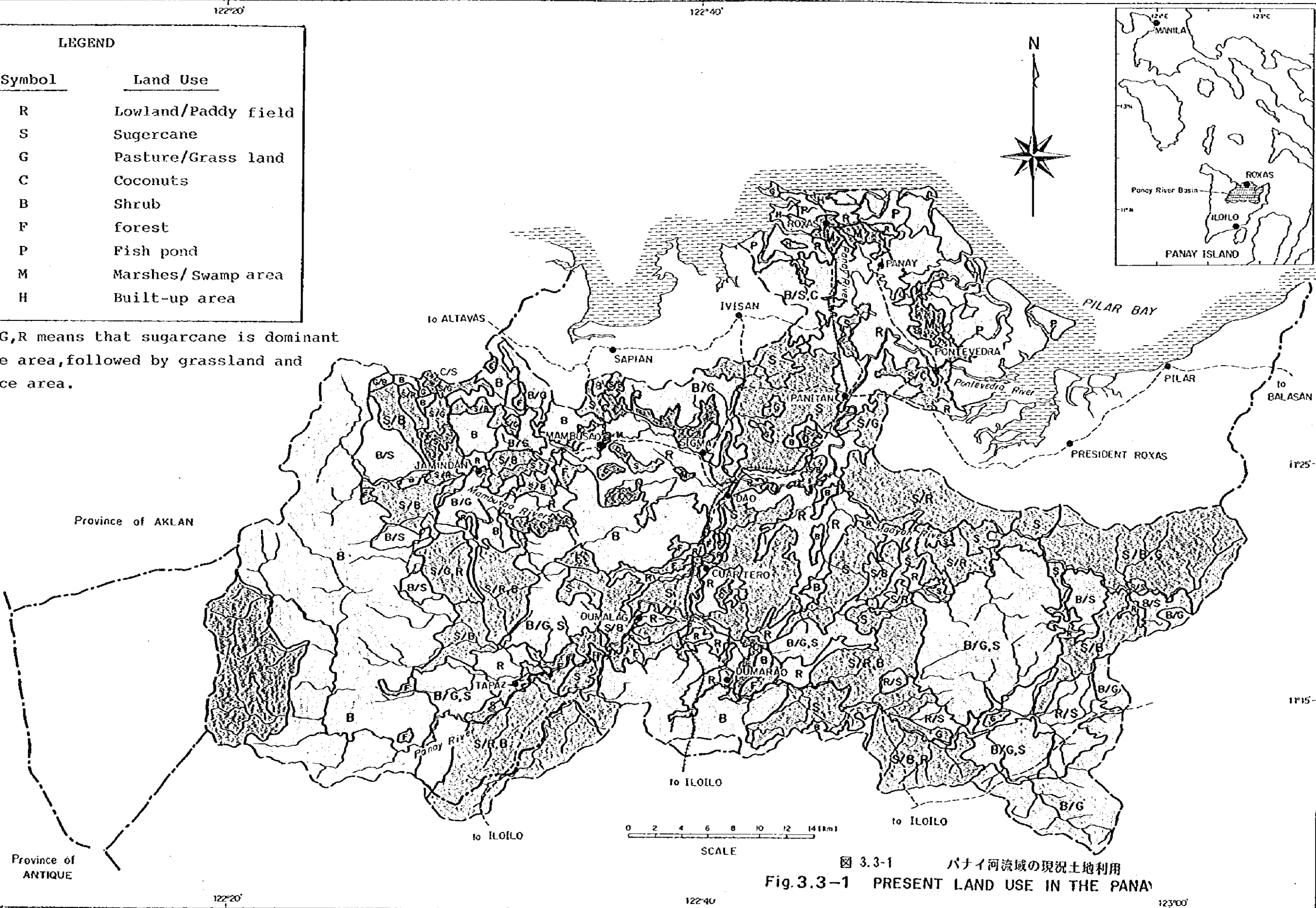

図 3.3-3 洪水解析のための河川区間区分

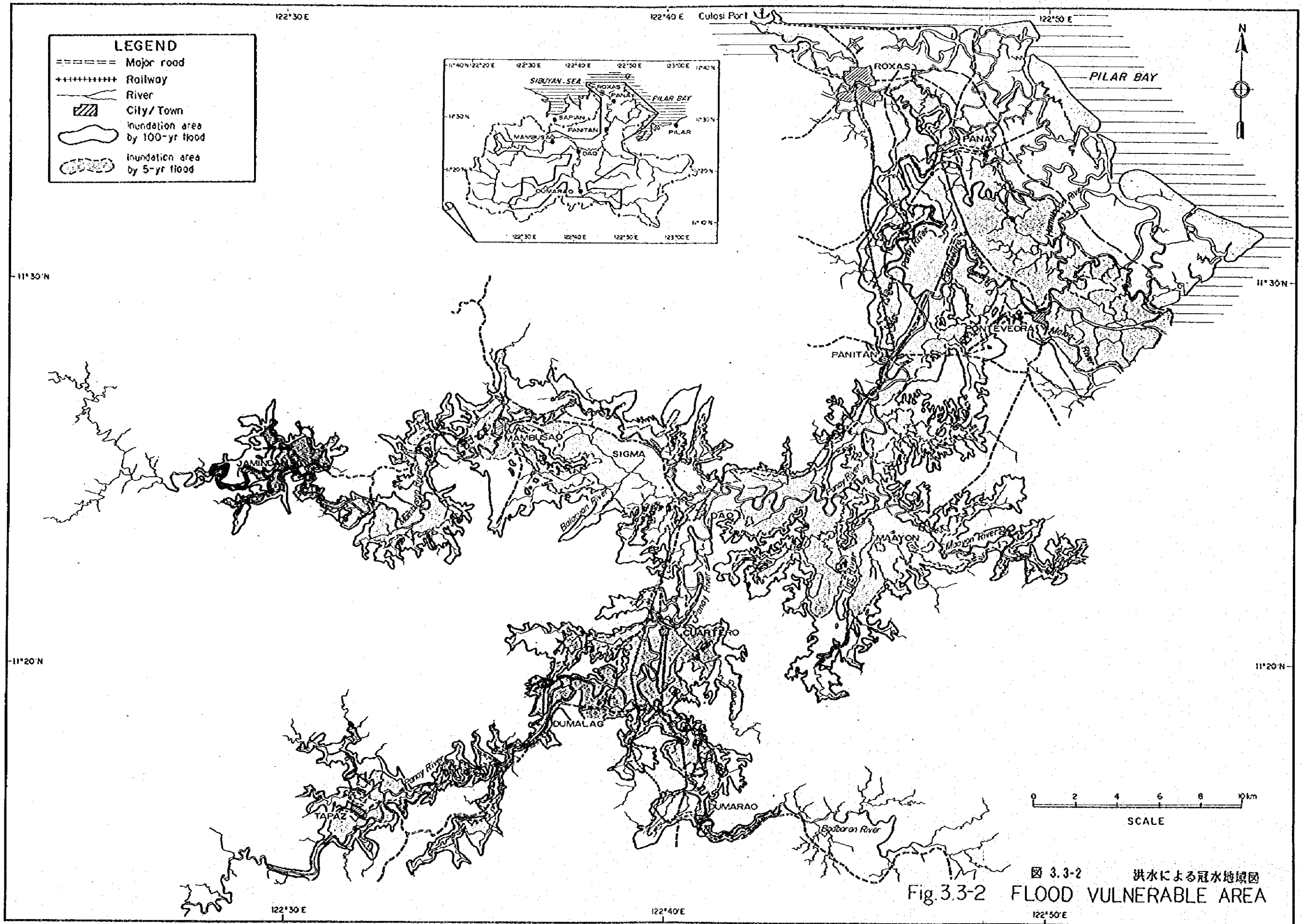
Fig. 3.3-3 DIVISION OF FLOOD ANALYSIS AREA BY RIVER STRETCH

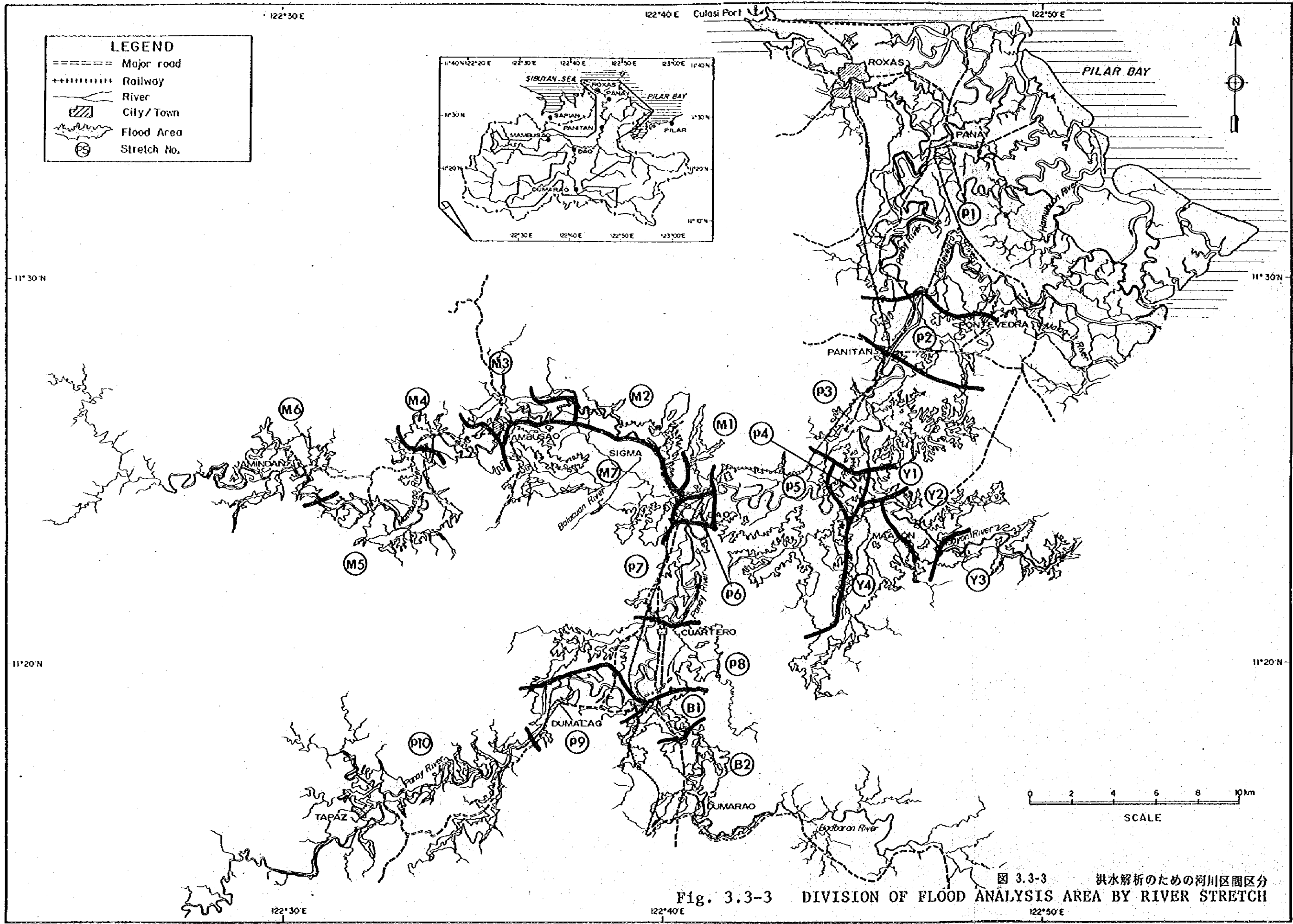
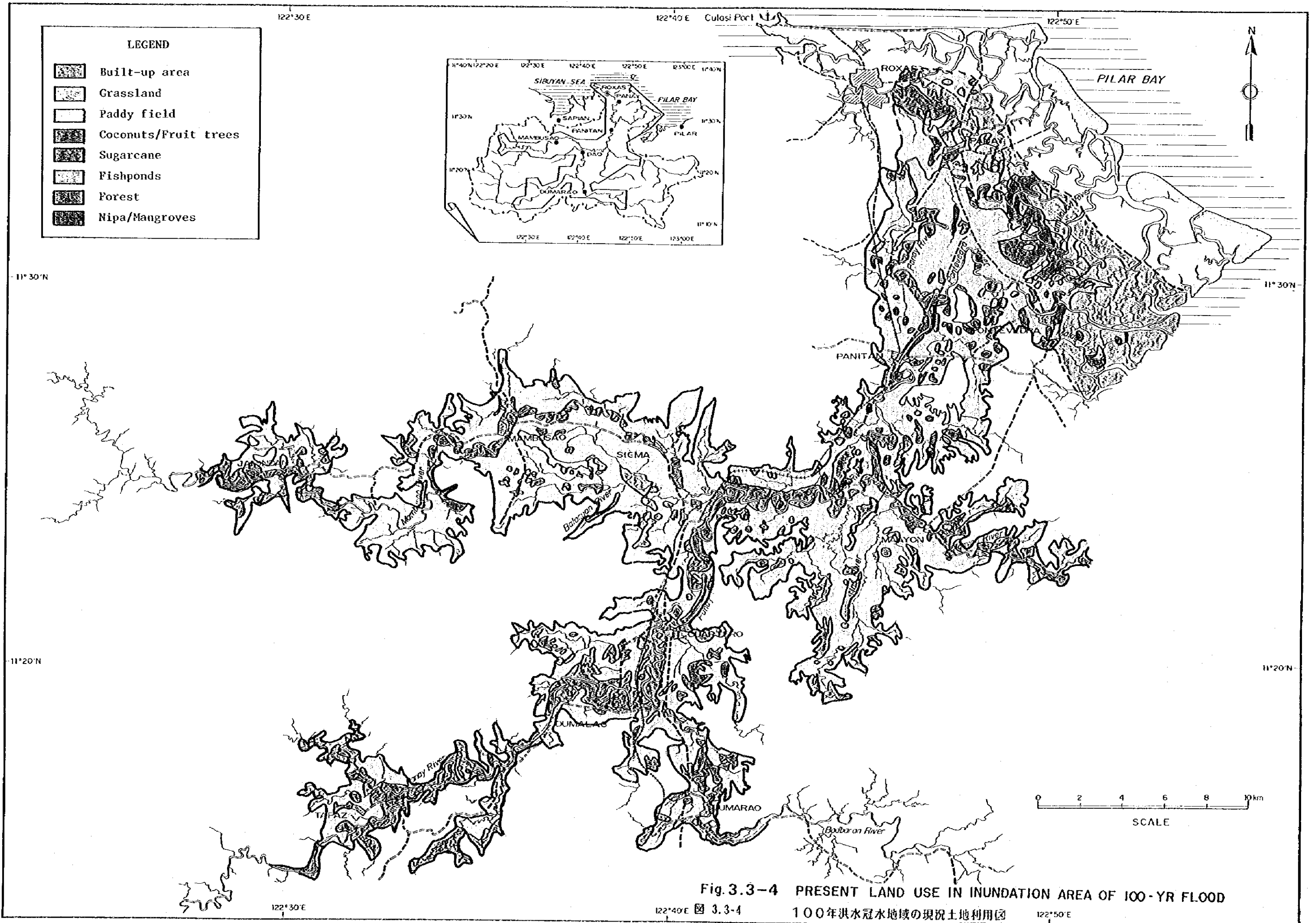

**LEGEND**

- Built-up area
- Grassland
- Paddy field
- Coconuts/Fruit trees
- Sugarcane
- Fishponds
- Forest
- Nipa/Mangroves

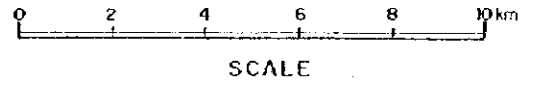
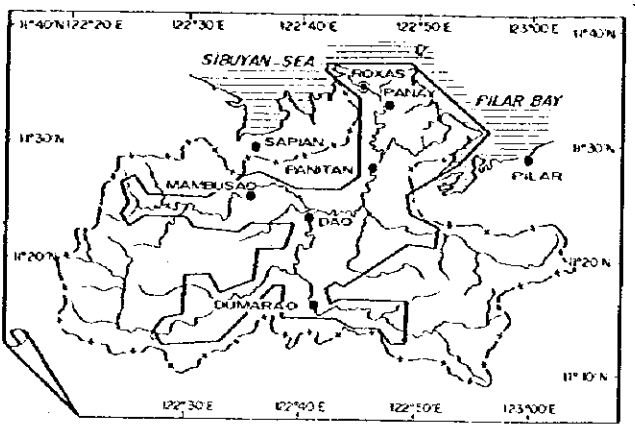

**Fig. 3.3-4 PRESENT LAND USE IN INUNDATION AREA OF 100-YR FLOOD**  
 100年洪水冠水地域の現況土地利用図



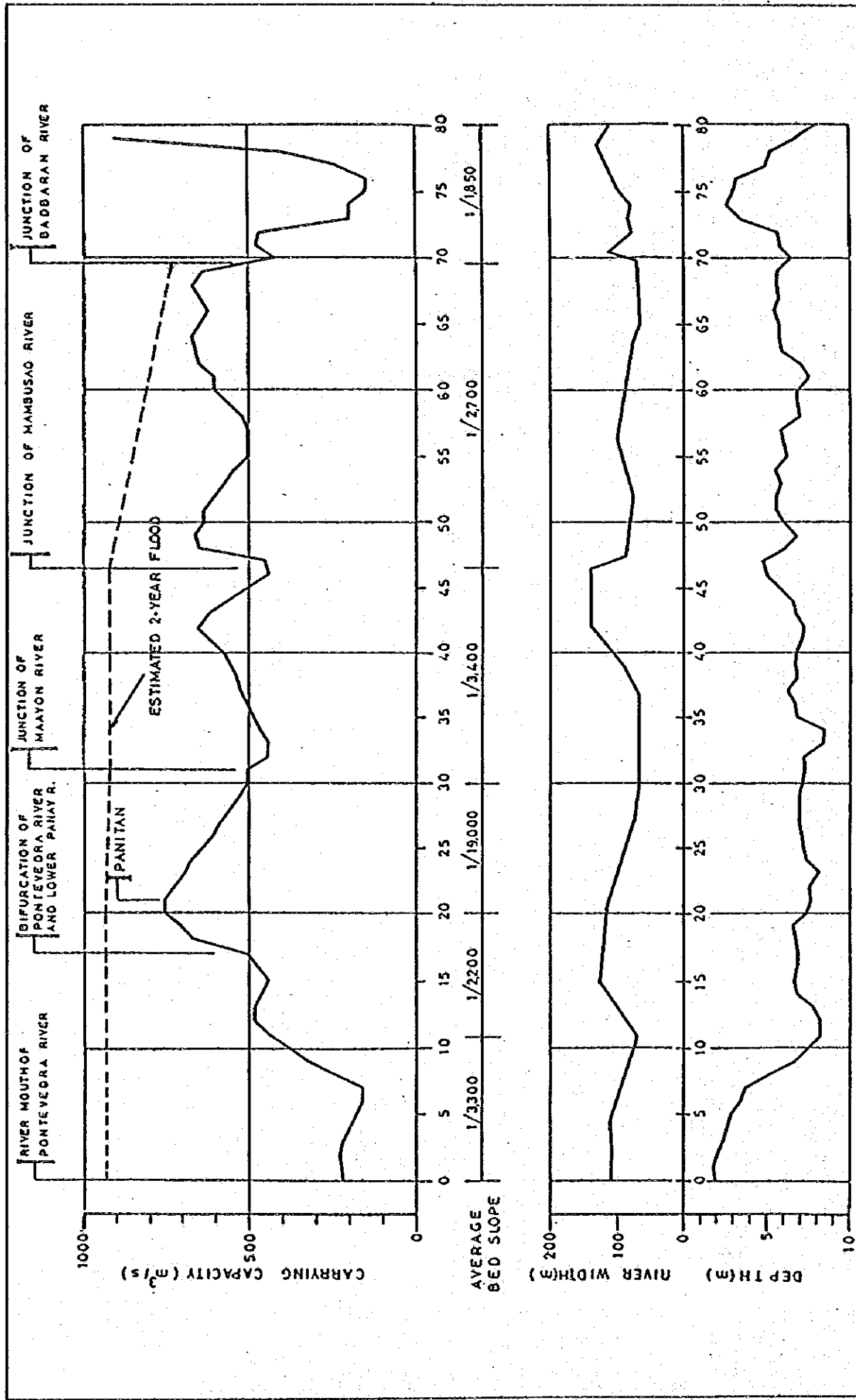
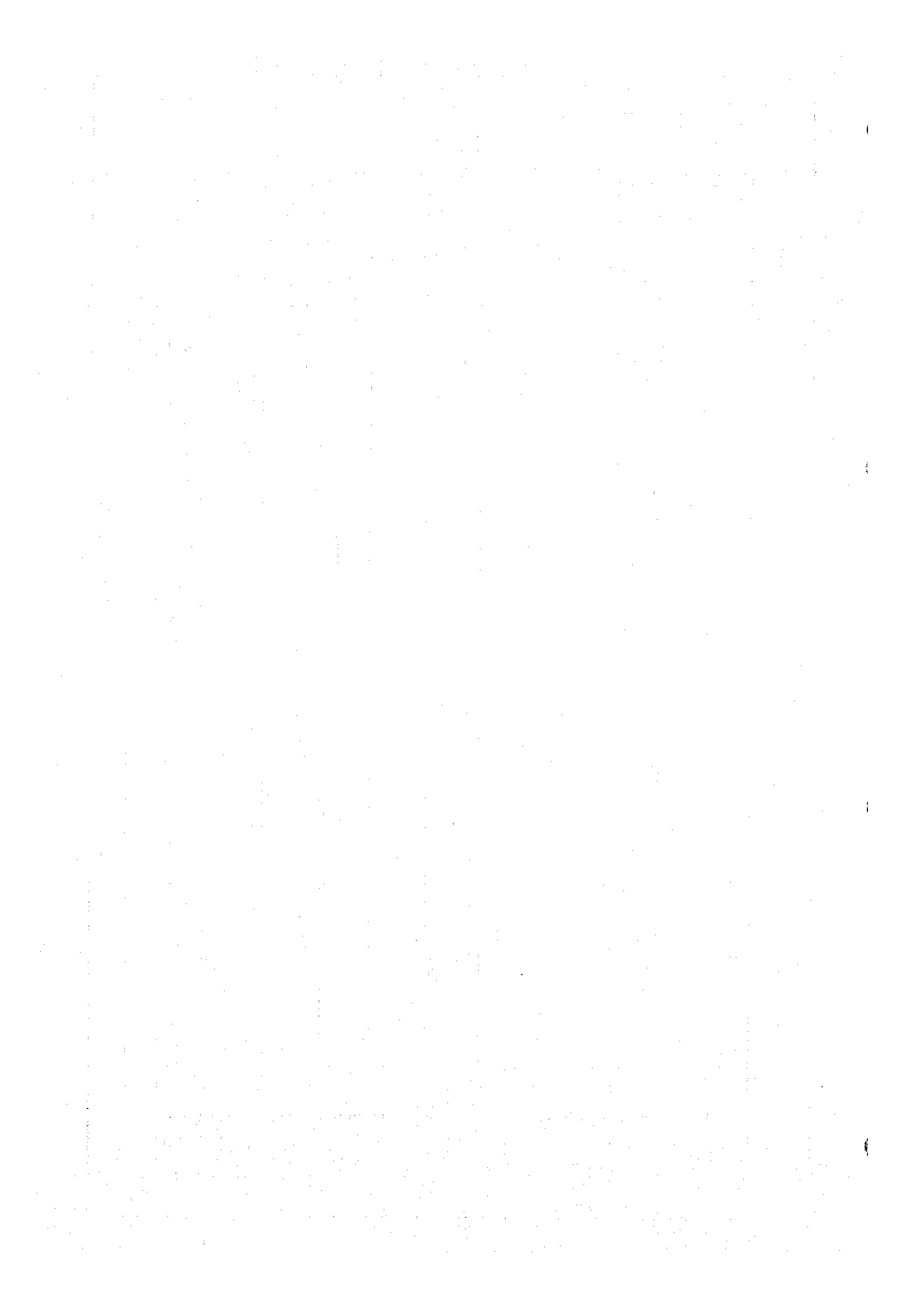

Fig. 3.5-1 CHARACTER OF PRESENT PANAY RIVER

图 3.5-1 潘尼河通水容量、河幅、及び水深





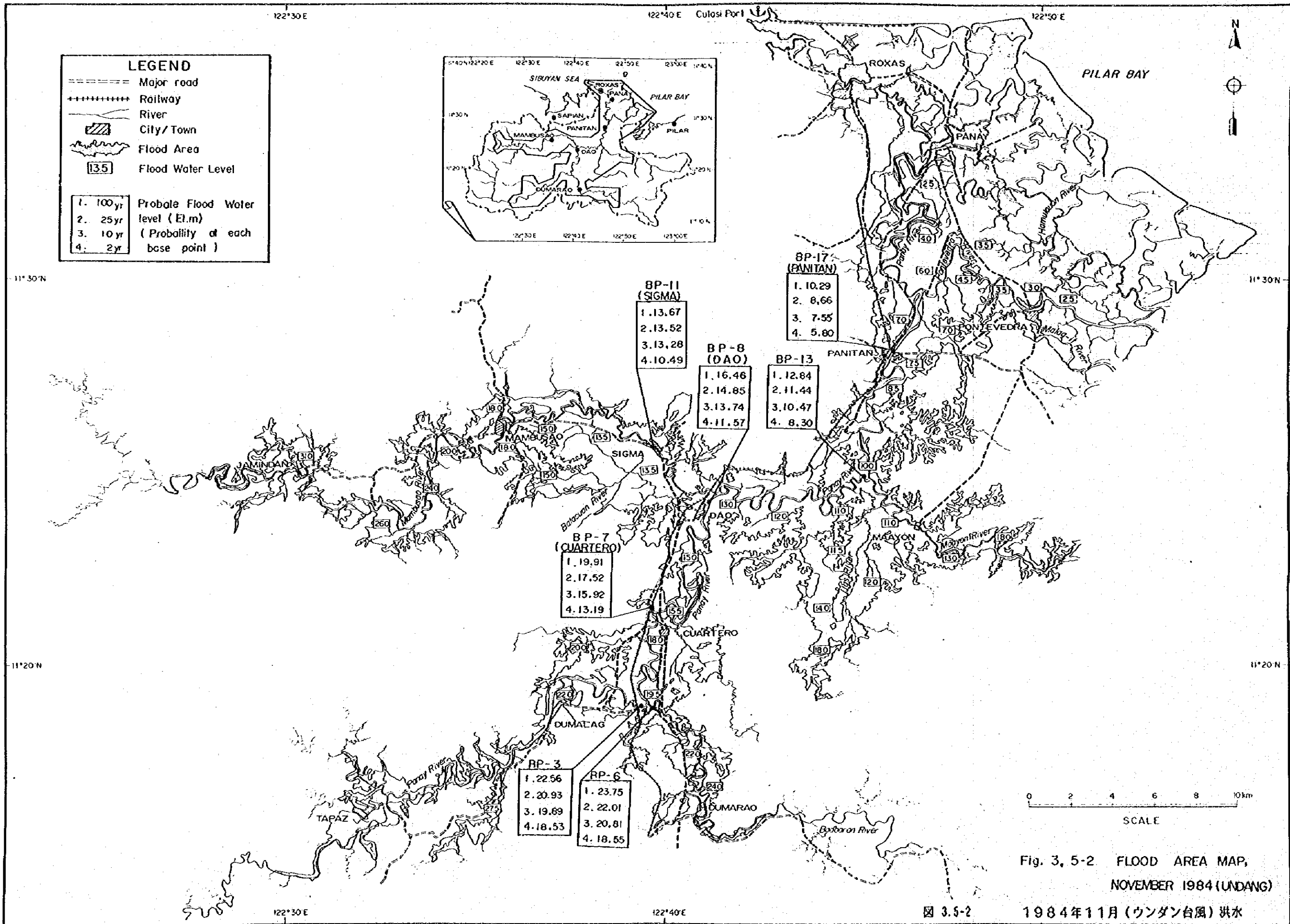
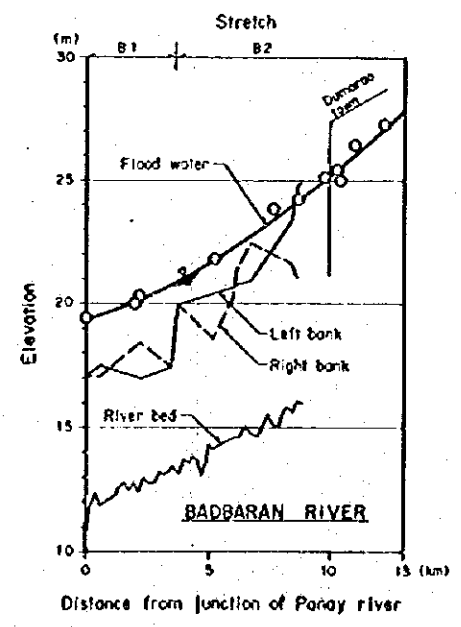
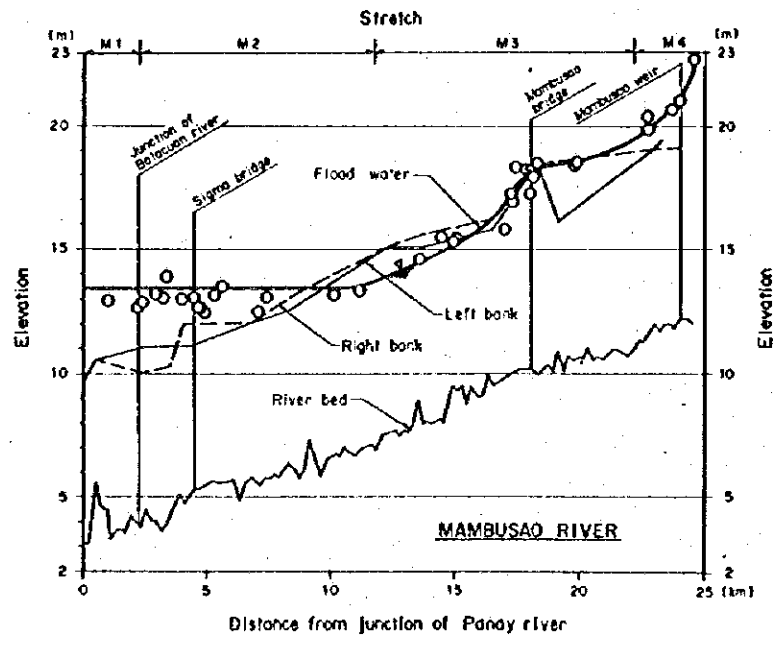
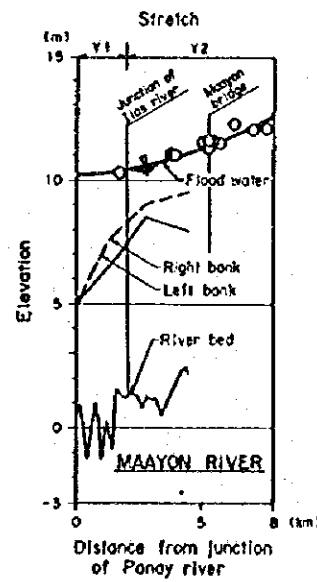
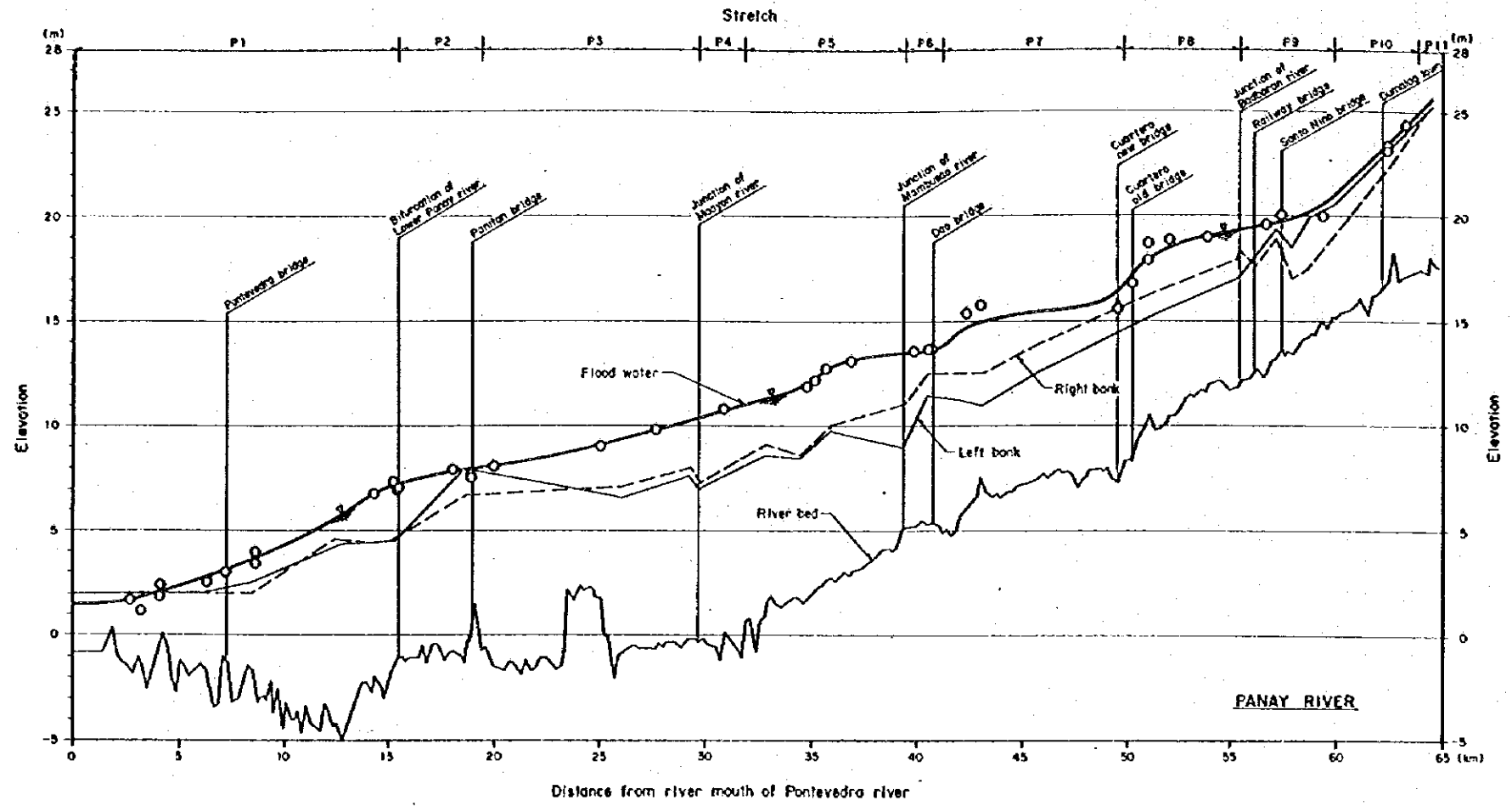

Fig. 3, 5-2. FLOOD AREA MAP, NOVEMBER 1984 (UNDANG)

図 3.5-2 1984年11月(ウندان台風)洪水



Remarks: O shows surveyed water level

図 3.5-3 ウンダン洪水の縦断面図  
Fig. 3.5-3 LONGITUDINAL WATER PROFILE OF UNDANG FLOOD



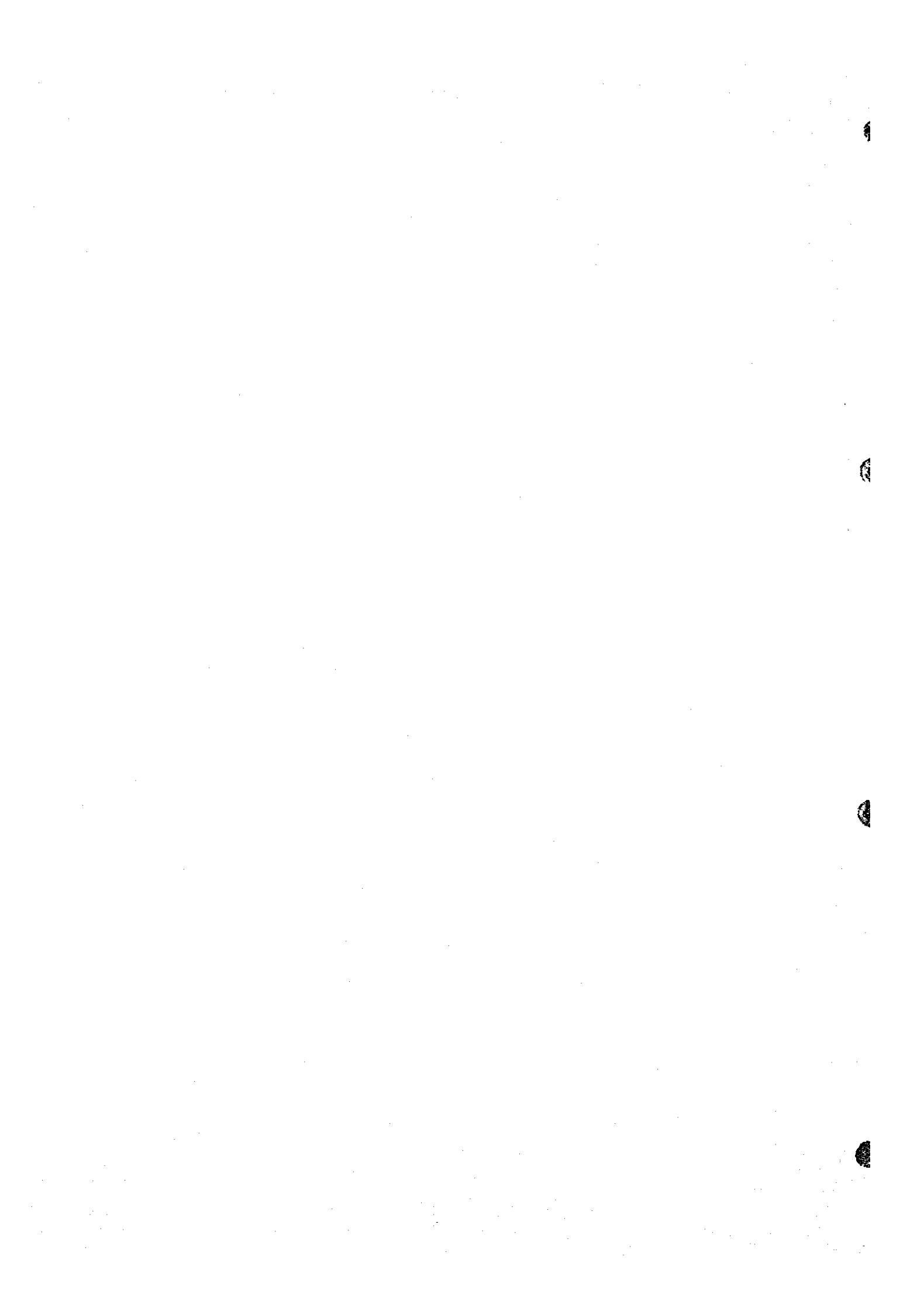

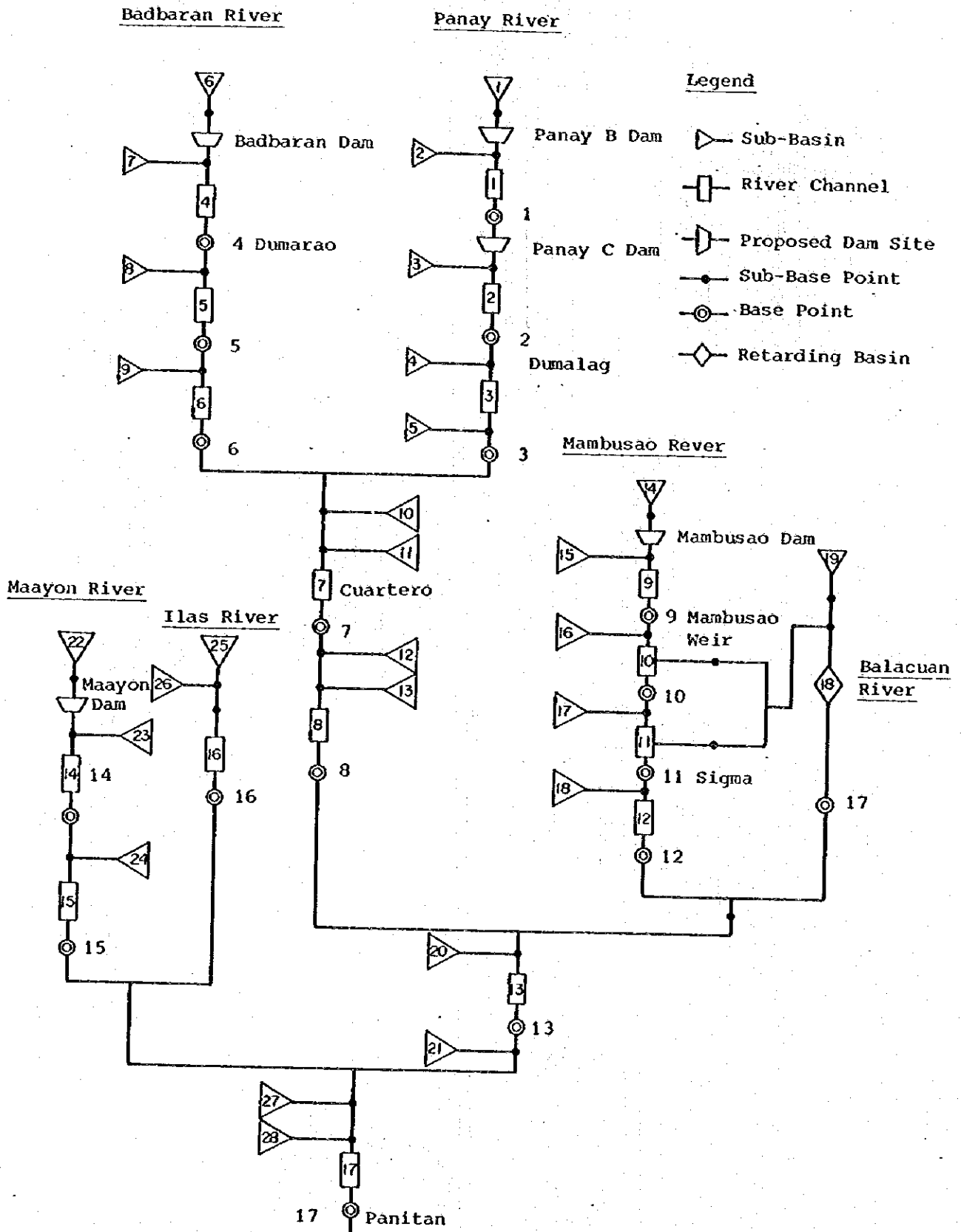

Fig. 3.5-4 RIVER SYSTEM MODEL  
 3.5-4 河川システムのモデル



図 3.5-5 現況河道の洪水流量配分図  
 Fig. 3.5-5 FLOOD FLOW DISTRIBUTION FOR PRESENT RIVER CONDITION  
 (PROBABILITY OF BASIN RAINFALL AT PANITAN)





KEY MAP

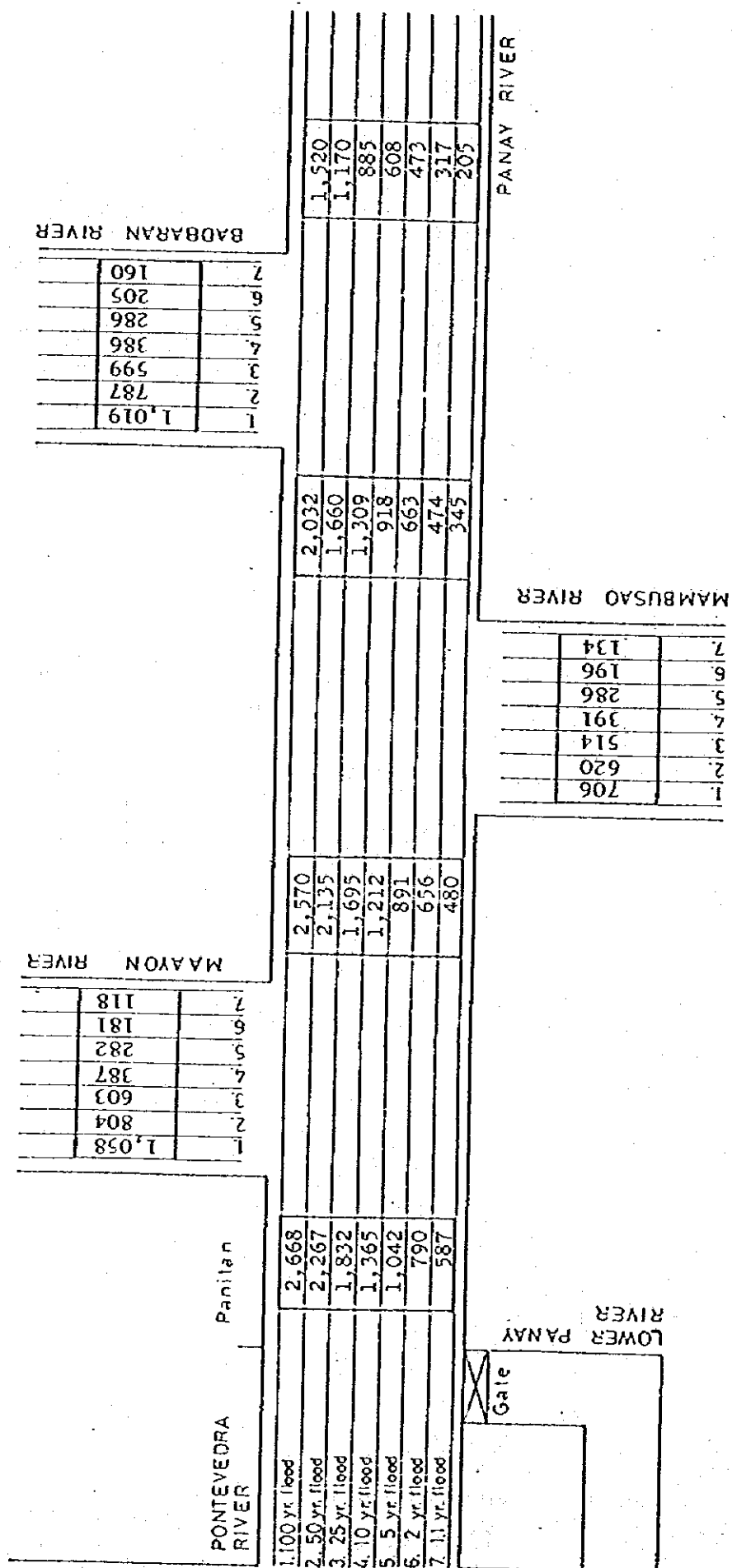
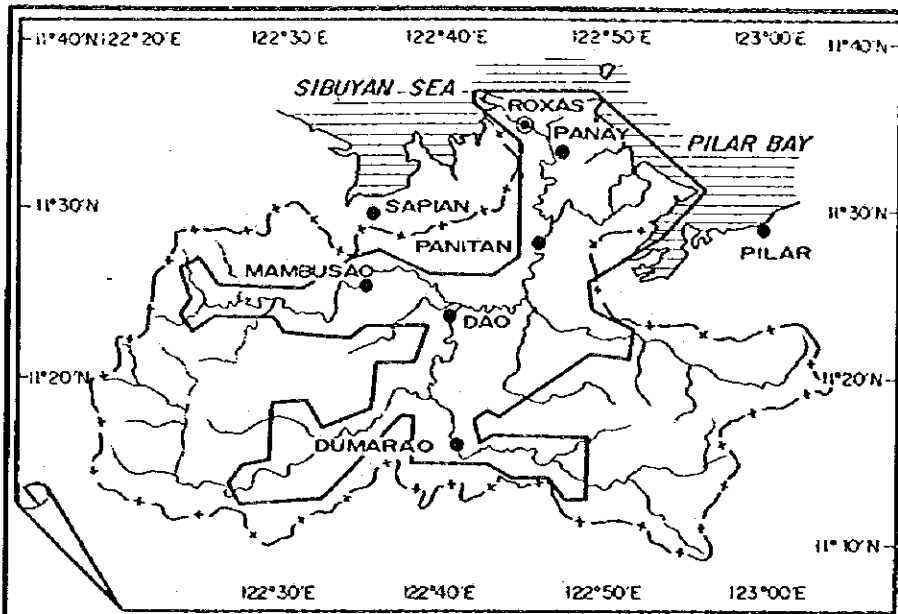





図 3.5-6 5年洪水の冠水深  
Fig. 3.5-6 INUNDATION DEPTHS - 5-YEAR FLOOD

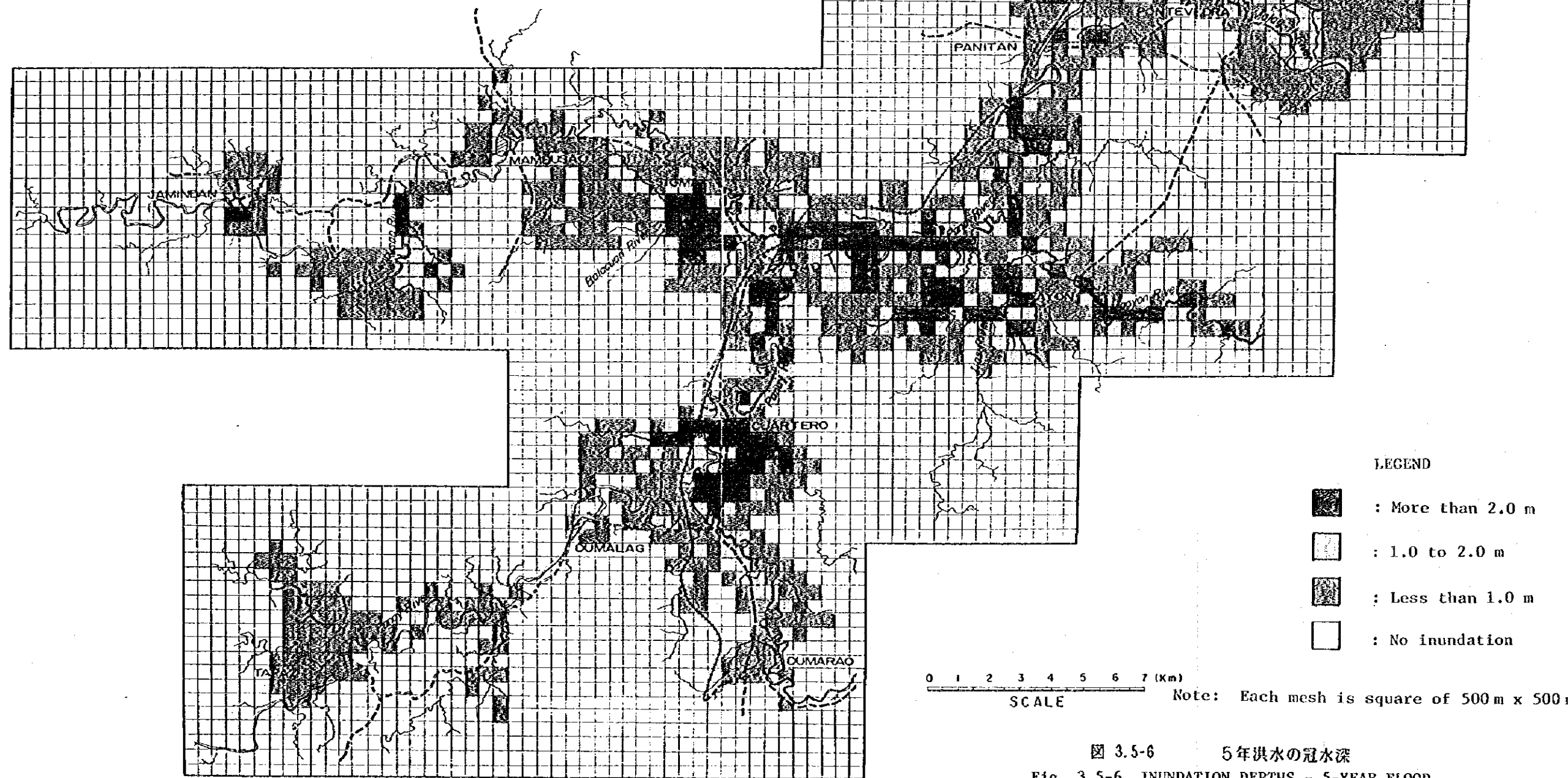
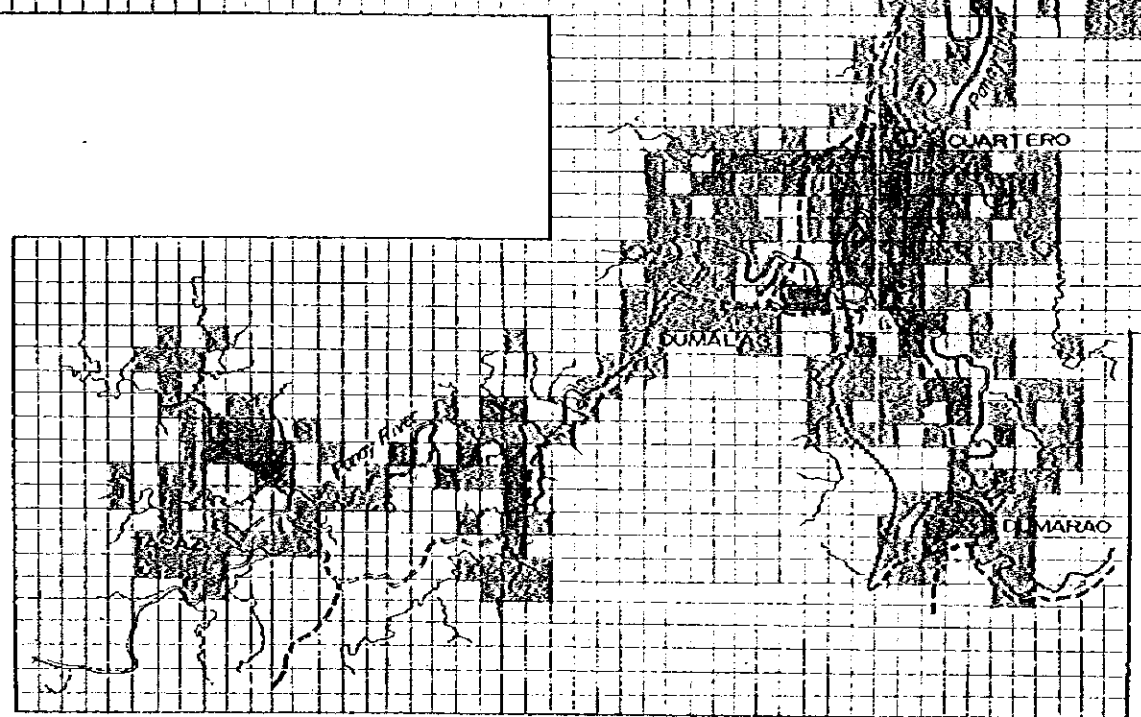
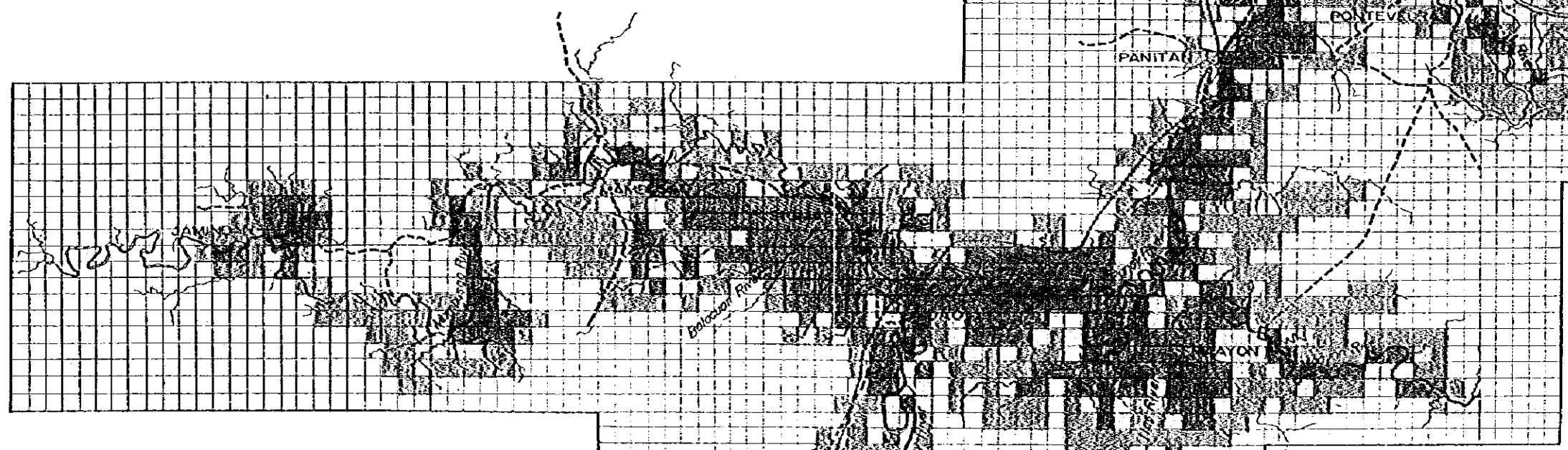
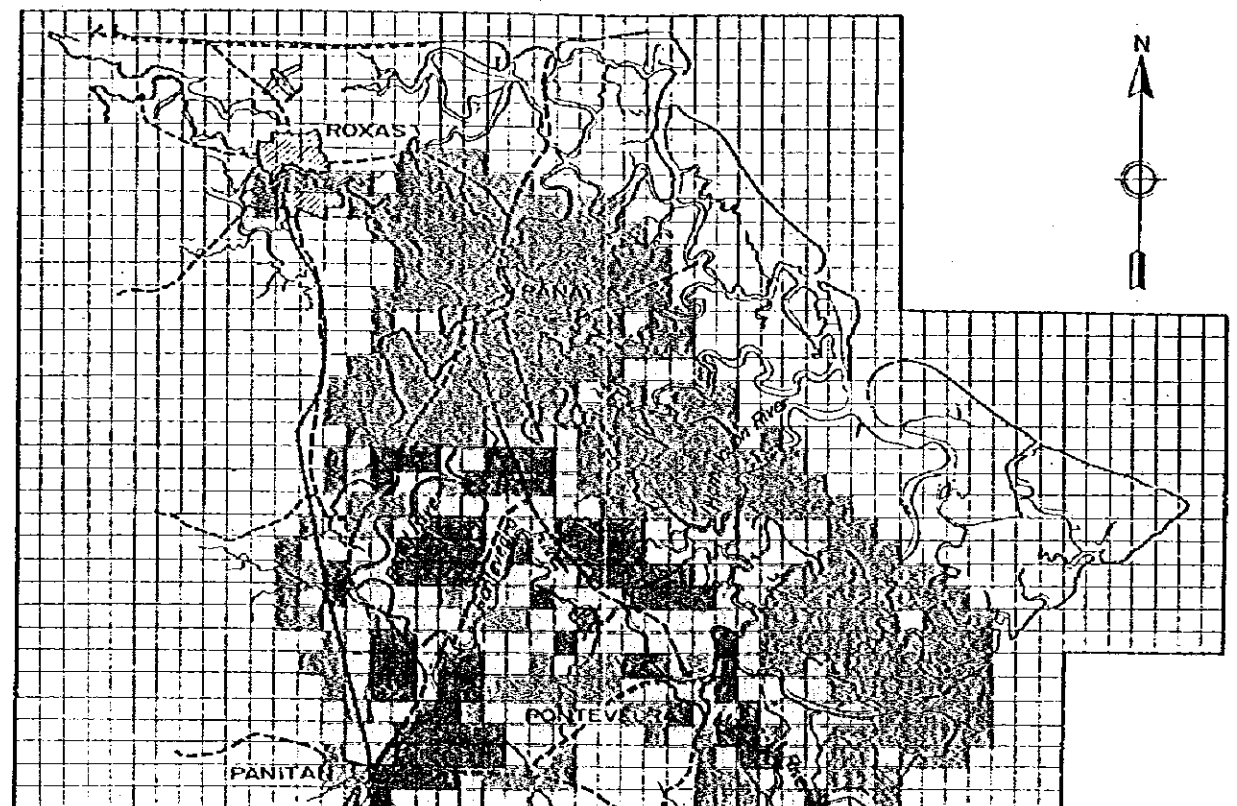
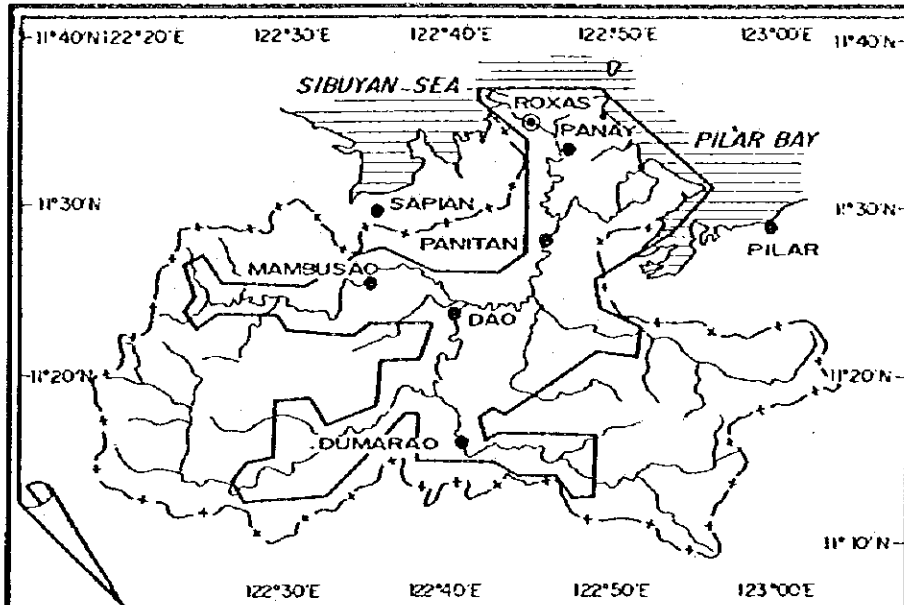

LEGEND

-  : More than 2.0 m
-  : 1.0 to 2.0 m
-  : Less than 1.0 m
-  : No inundation



Note: Each mesh is square of 500 m x 500 m.

図 3.5-7 25年洪水の冠水深  
Fig. 3.5-7 INUNDATION DEPTHS - 25-YEAR FLOOD