

THE REPUBLIC OF INDONESIA  
STUDY REPORT  
ON  
LONG TERM PLANNING  
FOR  
DEVELOPMENT OF TELECOMMUNICATIONS SYSTEM  
(VOLUME 1)  
LONG TERM DEVELOPMENT PLAN

February 1982

JAPAN INTERNATIONAL COOPERATION AGENCY

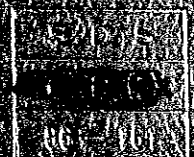



JICA LIBRARY



1031065[4]



**THE REPUBLIC OF INDONESIA**  
**STUDY REPORT**  
**ON**  
**LONG TERM PLANNING**  
**FOR**  
**DEVELOPMENT OF TELECOMMUNICATIONS SYSTEM**

**(VOLUME I)**

**LONG TERM DEVELOPMENT PLAN**

**FEBRUARY 1987**

**JAPAN INTERNATIONAL COOPERATION AGENCY**



## PREFACE

In response to the request of the Government of Indonesia, the Japanese Government has decided to conduct a study on the Long Term Planning for Development of Telecommunications System and entrusted the study to the Japan International Cooperation Agency (JICA).

JICA sent to Indonesia a study team headed by Mr. Junichi KUROBE, the Nippon Telecommunications Consulting Co., Ltd. from February 3 to March 29, 1986 and from June 15 to September 27, 1986.

The team had discussions with the officials concerned of the Government of Indonesia and conducted a field survey. After the team returned to Japan, further studies were made and the present report has been prepared.

I hope that this report will serve for the development of the Project and contribute to the promotion of friendly relations between our two countries.

I wish to express my deep appreciation to the officials concerned of the Government of Indonesia for their close cooperation extended to the team.

February, 1987



Keisuke Arita  
President

Japan International Cooperation Agency

国際協力事業団	
受入 月日 '87. 4. 06	108
登録No. 16112	78 SDS



# The Republic of Indonesia

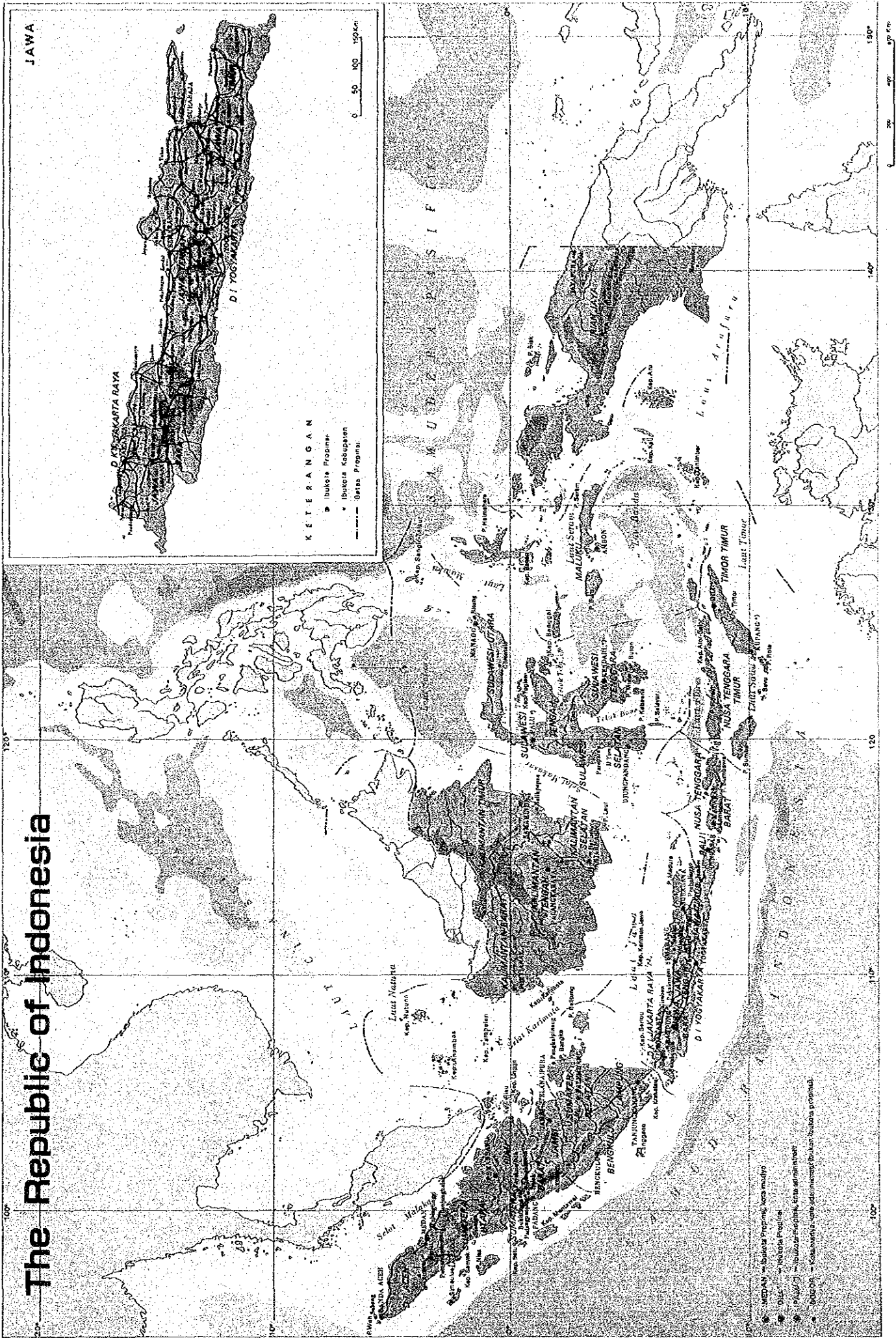

**KETERANGAN**

- ▣ Ibu kota Provinsi
- Ibu kota Kabupaten
- Batas Provinsi

D KRESKARTA RAYA

DI YOGYAKARTA

JAWA

\* MODAL = Badan Program, Badan  
 \* DIT = Departemen  
 \* PUS = Pusat  
 \* KEM = Kementerian  
 \* BUN = Badan Usaha  
 \* BUN = Badan Usaha



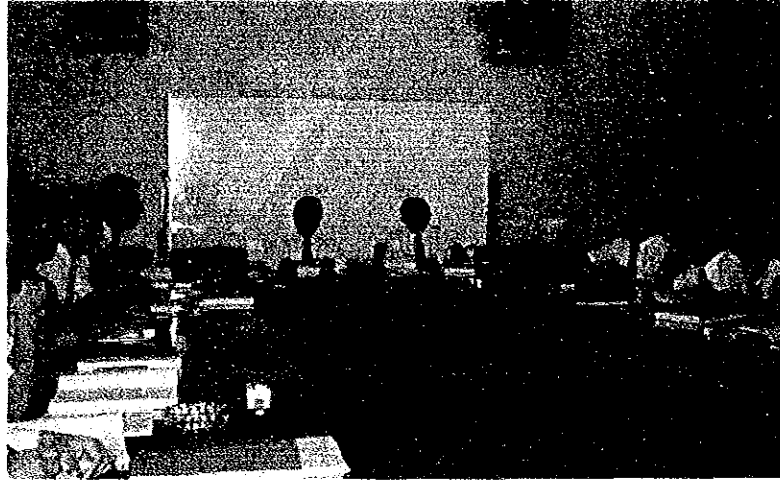

Photo.1 Discussion on Interim Report at PERUMTEL

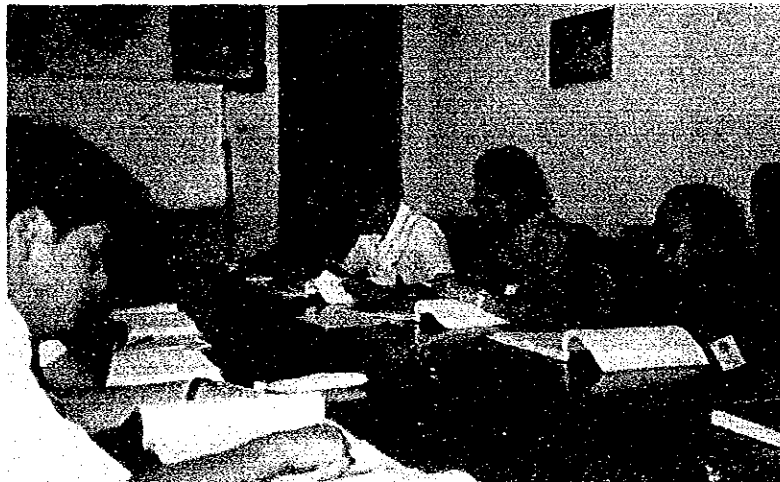

Photo.2 Discussion on Interim Report at DITJEN



Photo.3 Discussion on Final Draft Report at DITJEN POSTEL



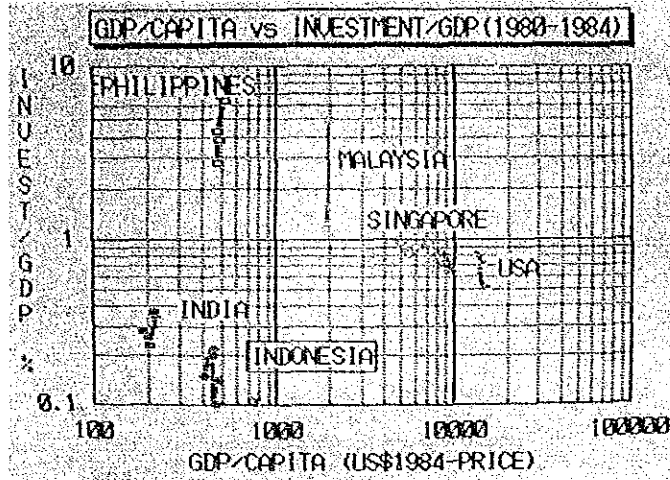

Photo.4 GDP/Capita vs. Telecommunication Investment/GDP

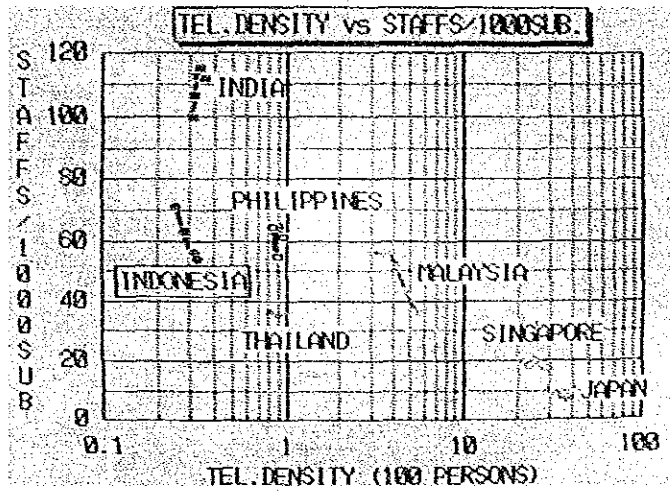

Photo.5 Telephone Density vs. Staffs /1000 Subscribers

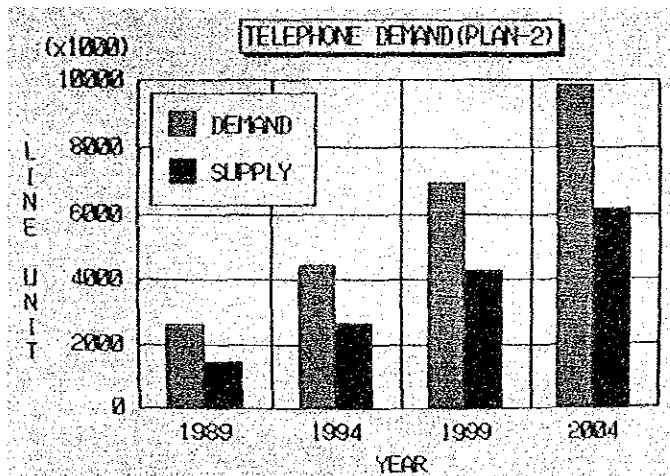

Photo.6 Telephone Demand in Indonesia (Supply Plan 2)



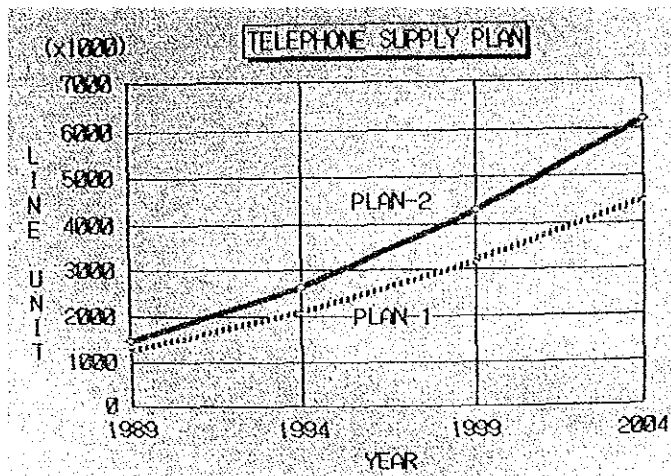

Photo.7 Telephone Service Supply Plans

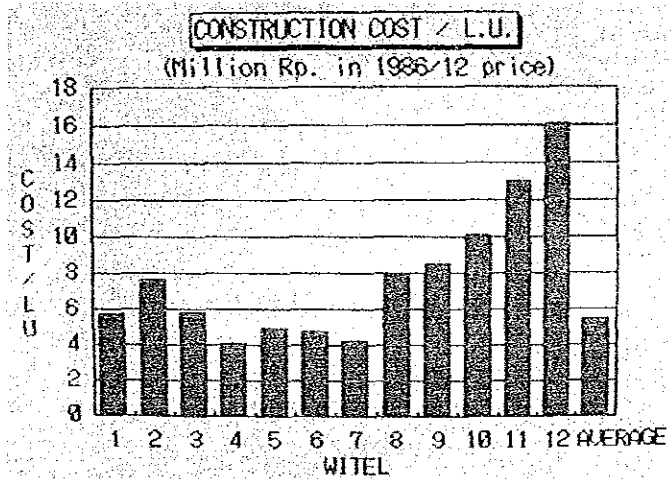

Photo.8 Construction Cost per Line Unit by WITEL

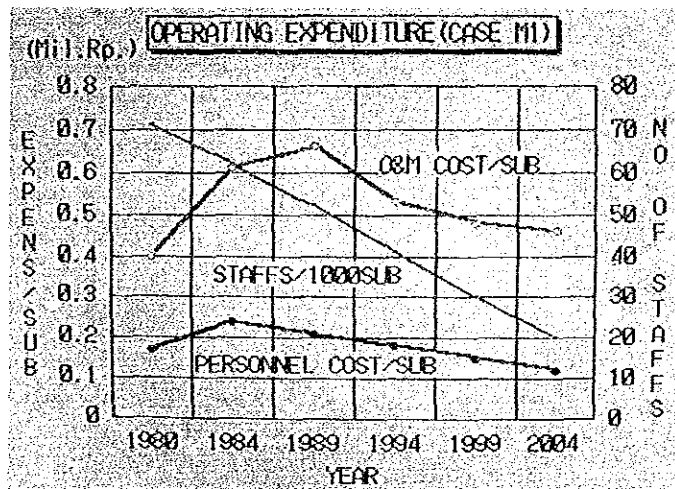

Photo.9 Operating Expenditure Reduction Strategy (M1)





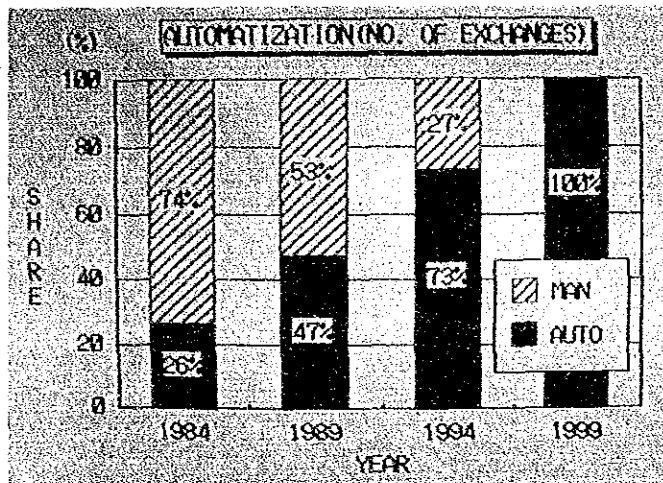

Photo.10 Automatization Plan (No. of Exchanges)

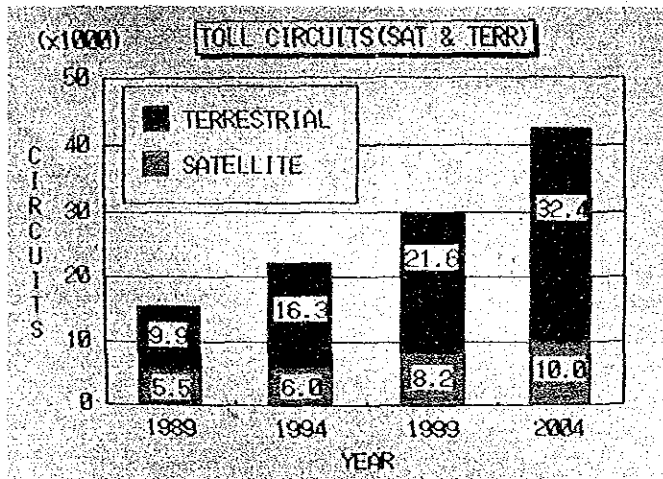

Photo.11 Toll Circuits Expansion Plan

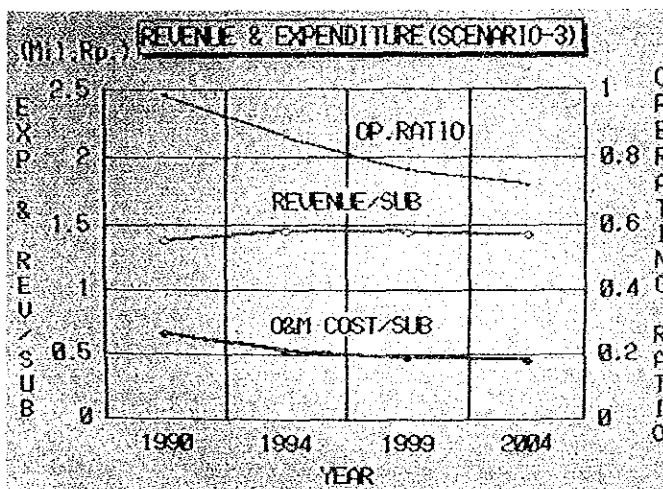

Photo.12 Revenue and Expenditure of Scenario-3



## CONTENTS

### VOLUME I LONG TERM DEVELOPMENT PLAN

	<u>Page</u>
SUMMARY AND PROPOSALS .....	1
CHAPTER 1 INTRODUCTION .....	47
1-1 Structure of the Study Report .....	49
1-2 Purpose and Process of the Study .....	50
1-3 Organization of the Study Team .....	53
CHAPTER 2 DEVELOPMENT OBJECTIVES AND STRATEGIES .....	59
2-1 Benefits of Telecommunications Development .....	61
2-2 Present Situations Concerning Telecommunications Development .....	63
2-3 Development Objectives and Strategies .....	68
2-4 Strategies Simulation Model .....	71
2-5 Development Scenarios .....	73
CHAPTER 3 THE STATE OF TELECOMMUNICATIONS IN INDONESIA .....	75
3-1 The Current Socio-Economic Conditions .....	77
3-2 The Current State of Telecommunications Services .....	87
3-3 The Current State of Telecommunications Facilities in Indonesia .....	98
3-4 The Current State of PERUMTEL Management .....	108
CHAPTER 4 TELECOMMUNICATIONS SERVICES SUBSCRIBER DEMAND .....	125
4-1 Telephone Service Subscriber Demand .....	127
4-2 Non-Telephone Service Subscriber Demand Forecast Method ...	142
4-3 Telex Service Subscriber Demand .....	143
4-4 Data Communication Subscriber Demand .....	147

4-5	Facsimile Service Demand .....	156
4-6	Paging Service Demand .....	160
4-7	Land-Mobile Radiotelephone Service Demand .....	165
<b>CHAPTER 5 TELECOMMUNICATIONS SERVICES TRAFFIC .....</b>		<b>171</b>
5-1	Telephone Service Traffic .....	173
5-2	Telegraph Service Traffic .....	177
5-3	Telex Service Traffic .....	181
<b>CHAPTER 6 INVESTMENT STRATEGIES .....</b>		<b>183</b>
6-1	Service Offering Plan .....	185
6-2	Supply Volume .....	192
6-3	Regional Distribution Plan .....	197
<b>CHAPTER 7 MANAGEMENT STRATEGIES .....</b>		<b>203</b>
7-1	Expenditure Management .....	206
7-2	Tariff Policies .....	217
7-3	Revenue Management .....	227
7-4	Financial Plan and Strategies Evaluation .....	234
<b>CHAPTER 8 TECHNICAL DEVELOPMENT STRATEGIES .....</b>		<b>243</b>
8-1	Innovations of Telecommunication Technology .....	245
8-2	Network Development Plan .....	248
8-3	Facility Modernization Plan .....	255
8-4	Backbone Transmission System Development .....	259
<b>CHAPTER 9 DEVELOPMENT SCENARIOS .....</b>		<b>267</b>
9-1	Optimum Development Scenarios .....	269
9-2	Development Policies of Next Three Five-Year Plans .....	276

<b>CHAPTER 10</b>	<b>FACILITY EXPANSION PLAN .....</b>	<b>279</b>
10-1	Telephone Service Facility .....	281
10-2	Non-Telephone Service Facility .....	285
10-3	Long Distance Transmission Facility .....	288
10-4	Network Management System .....	303
10-5	Training and Maintenance Center Facility .....	306
10-6	Equipment Supply and Construction .....	308
10-7	Project Implementation Program .....	309
<b>CHAPTER 11</b>	<b>ECONOMIC EVALUATION .....</b>	<b>317</b>
11-1	Consumer Surplus Analysis .....	319
11-2	Input-Output Table Analysis .....	322
<b>ANNEX 1</b>	<b>STRATEGIES SIMULATION MODEL .....</b>	<b>329</b>
<b>ANNEX 2</b>	<b>SOCIO-ECONOMIC INDEXES IN INDONESIA .....</b>	<b>351</b>
<b>ANNEX 3</b>	<b>WORLD TELEPHONE SERVICES .....</b>	<b>359</b>
<b>ANNEX 4</b>	<b>EXISTING TELECOMMUNICATIONS FACILITIES IN INDONESIA .....</b>	<b>365</b>
<b>ANNEX 5</b>	<b>MANAGERIAL INDEXES IN THE TELECOMMUNICATIONS SECTOR IN THE NINE COUNTRIES AND PERUMTEL's FINANCIAL STATEMENTS ....</b>	<b>405</b>
<b>ANNEX 6</b>	<b>TELECOMMUNICATIONS SERVICES SUBSCRIBER DEMAND .....</b>	<b>421</b>
<b>ANNEX 7</b>	<b>TELECOMMUNICATIONS SERVICES TRAFFIC AND TOLL CIRCUITS .....</b>	<b>427</b>
<b>ANNEX 8</b>	<b>THE INPUT-OUTPUT TABLE IN INDONESIA (1980) .....</b>	<b>439</b>

## LIST OF TABLES

		<u>Page</u>
1-3-1	Preliminary Study Team Members .....	53
1-3-2	Main Study Team Members .....	54
1-3-3	Indonesian Government Members Concerned in the Preliminary Study .....	55
1-3-4	Principal Indonesian Government Members Concerned in the Main Study .....	56
2-2-1	The Main Objectives of PELITA-IV, REPELITA-V and REPELITA-VI .....	63
3-1-1	Urban-Rural Population in Indonesia in 1980 .....	78
3-1-2	Urban Migration Figures in 1980 .....	79
3-1-3	Population Share Changes in Main Islands (%) .....	79
3-1-4	Changes of Urban Population Shares (%) .....	80
3-1-5	The Outline of PELITA-I, II and III .....	83
3-2-1	Telephone Service in Nine Countries (1984) .....	87
3-2-2	Telegraph Service in Nine Countries (1984) .....	88
3-2-3	Telex Service in Nine Countries (1984) .....	89
3-2-4	Currently Provided Telecomm. Services in the World .....	90
3-2-5	Telephone Service in Indonesia .....	91
3-2-6	Telegraph Service in Indonesia .....	93
3-2-7	Telex Service in Indonesia .....	95
3-3-1	Existing Facilities by Region (As of Dec. 1984) .....	99
3-4-1	Telephone Service Fees (US\$ in 1984) .....	116
3-4-2	Past Operation Results of PERUMTEL (1982-1985) .....	121
3-4-3	The Share of the Total Assets .....	120
3-4-4	Total Asset Share by WITEL 1984 (Million Rp.) .....	122
3-4-5	Results of Telephone Supply by WITEL .....	123
3-4-6	Telegraph and Telex Services by WITEL .....	124

4-1-1	Forecasted Telephone Demand in Indonesia .....	133
4-1-2	Sensitivity Analysis for Telephone Demand in Indonesia .....	134
4-1-3	Telephone Demand by WITEL Model .....	138
4-1-4	Telephone Demand by Kabupaten Model .....	140
4-1-5	The Forecasting Results of the Telephone Service Subscriber Demand .....	141
4-1-6	The Final Forecasting Result of The Telephone Service Subscriber Demand .....	141
4-3-1	Projections of Telex Service Subscribers .....	146
4-4-1	Projections of Data Communication Service Subscribers .....	150
4-4-2	Data Communication Service Subscribers by Business in Japan..	153
4-4-3	The Number of Potential Subscribers for Switched Data Communication Service .....	154
4-4-4	The Number of Potential Subscribers for Leased Circuit Data Communication Service .....	155
4-5-1	Facsimile Terminals in the World .....	156
4-5-2	BIROFAX Service Coverage .....	158
4-5-3	Communication Cost Comparison between Telex and Facsimile ...	159
4-5-4	Facsimile Service Demand in Indonesia .....	160
4-6-1	Radio Paging Users by Business Category .....	162
4-6-2	Paging Service Subscribers in the Kanto Area in Japan (1983).	163
4-6-3	Paging Service Subscriber Demands in Indonesia .....	163
4-6-4	Radio Paging Service Subscriber Demand in Cities .....	164
4-7-1	The Number of Land-Mobile Telephone Service Subscribers in Japan by Year .....	166
4-7-2	The Number of Land-Mobile Telephone Service Subscribers in Japan by Type .....	166
4-7-3	The Number of Land-Mobile Telephone Service Subscribers by Organization in Japan .....	167
4-7-4	The Number of Land-Mobile Telephone Service Subscribers in Japan (1985) .....	168
4-7-5	Proposed Land-Mobile Telephone Service Subscription Rate in Indonesia .....	168
4-7-6	Total Land-Mobile Telephone Demand in Indonesia .....	169
4-7-7	Land-Mobile Radiotelephone Service Demand .....	170

5-1-1	Telephone Service Traffic (Annual Pulse) .....	173
5-1-2	Telephone Service Traffic (Busy Hour Calling Rate) .....	174
5-1-3	Projections of Telephone Service Toll Traffic .....	176
5-2-1	Projections of Telegraph Service Traffic .....	179
5-3-1	Projections of Telex Service Traffic .....	182
6-1-1	Main User Category Expansion Plan .....	190
6-1-2	Telecommunication Network Expansion Plan .....	192
6-2-1	Telephone Service Supply Plans .....	195
6-2-2	Non-Telephone Service Supply Plan (Plan 1) .....	196
6-2-3	Non-Telephone Service Supply Plan (Plan 2) .....	196
6-3-1	Telephone Capacity Share by WITEL in 1989 .....	197
6-3-2	Telephone Density and IRR in 2004 .....	198
6-3-3	Telephone Supply Density by WITEL (Plan 1) .....	200
6-3-4	Telephone Supply Density by WITEL (Plan 2) .....	201
7-1-1	Construction Costs per Line Unit .....	208
7-1-2	Estimated Construction Costs .....	209
7-1-3	Estimated Operating Expenditure .....	214
7-1-4	The O&M Costs per Subscriber in 2004 .....	217
7-2-1	Telephone Tariff in Indonesia .....	219
7-2-2	SLDD and Interlocal (Manual Trunk Call) Fee .....	220
7-2-3	Past Installation Fee .....	221
7-2-4	Past Monthly Rental Fee of Telephone .....	222
7-2-5	Past Call Fee of Automatic Telephone Service .....	222
7-2-6	The Results of Sensitivity Analysis of the Installation Fee..	225
7-2-7	Proposed New Zoning Plan .....	226
7-3-1	Revenue Estimates (Current Tariff) .....	229
7-3-2	Results of Revenue Estimates .....	232
7-4-1	Results of Simulation Study .....	239
8-2-1	Number of Switching Centers up to 2004 .....	250
8-2-2	Existing Telex Switching Centers .....	251
8-2-3	Proposed Extension of NCC and ANP .....	252
8-3-1	Switching System Automatization Plan .....	255
8-3-2	Digitalization of Exchange by WITEL .....	256



8-3-3	Retirement Plan of the Existing Analog Switching System .....	257
8-3-4	Switching System Digitalization Plan .....	257
8-4-1	No. of Required Circuits in Backbone Routes .....	259
8-4-2	Distribution of Long Distance Circuits between Terrestrial and Satellite Systems .....	261
9-1-1	Development Scenario-1 (Optimum Scenario on Plan-1) .....	271
9-1-2	Development Scenario-2 (Alternative Scenario on Plan-1) .....	272
9-1-3	Development Scenario-3 (Optimum Scenario on Plan-2) .....	273
9-1-4	Development Scenario-4 (Alternative Scenario on Plan-2) .....	274
10-1-1	Capacity Expansion Plan for Telephone Facility .....	281
10-1-2	Proposed Telephone Exchanges to be Installed up to 2004 .....	282
10-1-3	Subscriber Line Extension Plan up to 2004 .....	285
10-2-1	Average Distance and Required No. of Telegraph Office in Kabupaten .....	286
10-2-2	Telegraph Office Installation Plan up to 2004 .....	286
10-2-3	Expansion Plan for Non-Telephone Service Facilities .....	287
10-3-1	Comparison for Alternative Transmission Routes .....	293
10-3-2	Launching Schedule of PALAPA Satellite .....	300
10-3-3	Available Circuits by PALAPA Satellite .....	301
10-3-4	The Number of Earth Stations up to 2004 .....	303
10-6-1	Main Project in REPELITA-V .....	312
10-6-2	Main Project in REPELITA-VI .....	314
11-1-1	Consumers Surplus .....	320
11-2-1	The Input Output Coefficients of the Communication Sector ...	325

## LIST OF FIGURES

		<u>Page</u>
1-2-1	Study Flow for Long Term Telecommunication Development Planning .....	52
1-3-1	Organization of Department of Tourism, Posts and Telecommunications .....	58
2-4-1	The Diagram of Policy Variable Impact .....	72
2-5-1	Development Scenarios Formulation Flow .....	73
3-1-1	The GDP Growth Rate .....	84
3-2-1	Telephone Service in Indonesia .....	91
3-2-2	Telegraph Service in Indonesia .....	93
3-2-3	Telex Service in Indonesia .....	95
3-3-1	Current SLJJ Network (1985) .....	102
3-3-2	Current Telex Network (1985) .....	103
3-3-3	Configuration of PACKSATNET (1985) .....	104
3-3-4	PERUMTEL's Packet Data Communication System .....	104
3-3-5	P.T. INDOSAT's Packet Data Communication System .....	105
3-3-6	Existing Backbone Microwave Systems and Constructed Years ...	106
3-3-7	Existing Earth Stations for Domestic Satellite Communication System .....	107
3-4-1	Organization Chart of PERUMTEL .....	109
3-4-2	GDP per Capita vs. Telecommunication Investment Share to GDP.	112
3-4-3	Increased Number of Subscribers/Waiting Applicants vs. Waiting Applicants/Sub. ....	112
3-4-4	Telephone Density vs. Total Staff per Subscriber .....	113
3-4-5	Total Staff per Subscriber vs. Operating Ratio .....	113
3-4-6	Telephone Density vs. Revenue/Subscriber .....	114
3-4-7	Comparison between Indonesia and Thailand .....	117
3-4-8	Comparison between Indonesia and Malaysia .....	117
3-4-9	Comparison between Indonesia and Japan .....	118
3-4-10	Comparison between Indonesia and U.S.A. ....	118

4-1-1	Demand Forecasting and Supply Planning Flow .....	129
4-1-2	Telephone Density and Total Demand .....	131
4-1-3	Results of Telephone Demand Forecast in Indonesia .....	135
4-1-4	Telephone Subscribers vs Subscription Fee .....	137
4-3-1	International Data of Telex Service (1981-1984) .....	145
4-4-1	International Data of Data Communication Service (1981-1984).	148
4-4-2	Correlation between No. of On-line Computer and No. of Dedicated Circuits in Japan .....	151
4-5-1	Number of Facsimile Terminals in Japan .....	157
4-6-1	Radio Paging Service in Japan .....	161
5-2-1	International Data of Telegraph Traffic (1980-1984) .....	180
6-1-1	Telecommunication Services provided by Low Speed Transmission Media .....	186
6-1-2	Telecommunication Services Provided by High Speed Transmission Media .....	187
6-2-1	Telephone Density and GDP/Capita of the Countries in the World .....	194
7-1-1	Relation Between Total No. of Staffs and No. of Telephones in the World (1983) .....	211
7-1-2	Proposed Man-Power Plan .....	215
7-1-3	Estimated Operating Expenditure .....	216
7-4-1	Fund Flow Diagram .....	235
7-4-2	Fund Procurement in PELITA-IV .....	235
7-4-3	The Feasible Combination of Strategies .....	241
8-2-1	Network Integration Plan .....	249
8-2-2	Telephone Network Development Plan .....	253
8-2-3	Telex Network Development Plan .....	253
8-2-4	Packet Data Communication Network Development Plan .....	254
8-3-1	Switching Systems to be Replaced due to Termination of Service Life.....	258
8-4-1	Cost Comparison between Terrestrial and Satellite Systems ...	262
8-4-2	Circuit Share of Terrestrial and Satellite .....	263

9-1-1	Revenue and Expenditure of Scenario-1 .....	275
9-1-2	Revenue and Expenditure of Scenario-3 .....	275
10-1-1	Selection Chart of Optimum System .....	283
10-1-2	Number of Exchanges in Kabupaten .....	284
10-3-1	Backbone Terrestrial Transmission Link in The Year of 2004 ..	289
10-3-2	Service Life of Existing Backbone Terrestrial Transmission Link .....	292
10-3-3	Backbone Terrestrial Transmission Link Plan in PELITA-IV ....	295
10-3-4	Backbone Terrestrial Transmission Link Plan in REPELITA-V ...	296
10-3-5	Backbone Terrestrial Transmission Link Plan in REPELITA-VI ..	297
10-3-6	Backbone Terrestrial Transmission Link Plan in REPELITA-VII .	298
10-3-7	The Number of Earth Stations in 2004 .....	302
11-1-1	The Telephone Service Market .....	319
11-2-1	The Input-Output Structure of Indonesia in 1980 .....	323
11-2-2	The Sector Classification .....	324
11-2-3	Sector Classification According to the Dependency Coefficients .....	327

## WORDS AND ABBREVIATIONS

DITJEN POSTEL	:	Directorate General of Posts and Telecommunications
PERUMTEL	:	Telecommunication Common Carrier in Indonesia
WITEL	:	Regional Bureau of PERUMTEL
JICA	:	Japan International Cooperation Agency
PELITA-IV	:	The 4th 5 Year National Development Plan
REPELITA-V	:	The 5th 5 Year National Development Plan
Kotamadya	:	Municipality
Kabupaten	:	Regency
Kecamatan	:	Sub District
Desa	:	Village
ISC	:	International Switching Centre
TC	:	Tertiary Centre
SC	:	Secondary Centre
PC	:	Primary Centre
LE	:	Local Exchange
RSU	:	Remote Switching Unit
L.U.	:	Line Unit
IDN	:	Integrated Digital Network
ISDN	:	Integrated Services Digital Network
PALAPA	:	Name of Indonesian Satellite
SBB	:	Large Type Earth Station
SBS	:	Medium Type Earth Station
SBK	:	Small Type Earth Station
SCPC	:	Single Channel Per Carrier
GDP	:	Gross Domestic Product
IRR	:	Internal Rate of Return



**SUMMARY AND PROPOSALS**





## SUMMARY AND PROPOSALS

### 1. Background of the Study

This study was made by the Japan International Cooperation Agency (JICA) in 1986, aiming at establishing "the Long-Term Development Plan up to the Year 2004" for the domestic public telecommunications systems operated by Perusahaan Umum Telekomunikasi (PERUMTEL), the Government of Indonesia. The three key themes discussed in the study are:

- 1) Establishment of development objectives up to the year 2004 and study of proper strategies for them.
- 2) Formation of basic plans for network and facilities expansion.
- 3) Financial and economic evaluation of the plans and project formation.

For the above study, the following three new methods were introduced:

- 1) Multiple regression models to make more systematic demand forecasting.
- 2) Development of an econometric simulation model in evaluating financial performances of investment plans.
- 3) A use of the Input-Output Table in analyzing economic impacts of telecommunications development.

## 2. Development Objectives and Strategies

### (1) Objectives

Main objectives of telecommunications development in Indonesia are considered to be as follows, judging from the significance of telecommunications development and other circumferential conditions:

- 1) Provision of the telecommunications services which support national development (development of infrastructure).
- 2) Improvement of the services in quantity and quality (reduction of waiting applicants and unsuccessful calls through automatization of the services).
- 3) Improvement of financial conditions of PERUMTEL (promotion of self-financing capability).

Based on the above objectives and in due consideration of comparable conditions in other ASEAN nations, the individual targets to be realized in the year 2004 were determined.

**Service Categories :** The main body of the nationwide services consists of telephone, telegraph and telex. In the urban areas, various kinds of non-telephone services will be introduced through the realization of ISDN.

**User Categories :** The first priority of the service provision goes to business and official-use customers. In the urban areas, some of residential demands will also be satisfied.

**Network Coverage :** The networks will be developed mainly in the urban areas (Kotamadya and Kabupaten capitals), and that for telephone service will

also be expanded to each rural area (Kecamatan and Desa centers). This realizes the rural development target in the ITU Kuala Lumpur Declaration, i.e., "Telephone service shall be available within any 3 km radius for all people".

Telephone Density : 5 - 10/100 persons in the urban areas  
(1-3/100 persons in 1985).  
1.8 - 2.5/100 persons in the whole nation  
(0.3/100 persons in 1985).

Waiting Periods for : Minimum 2 weeks, maximum 3 years in the  
Subscription urban areas.  
Maximum 5 years in the rural areas.

Service Standard : The telephone service will be provided by the  
automatic dialing. The telegrams will be  
delivered in one or two days.

Operating Standard : The operating ratio after tax will be less  
of PERUMTEL than 0.9. The IRR of investment will be more  
than 18%.

## (2) Strategies

To achieve the development targets discussed in the previous section, the following items are studied as strategic variables.

Investment Strategies

- Service categories ]
- User categories ] ..... Service offering plan
- Network coverage ]
- Impact of economic power ]
- Supply speed ] ..... Annual supply plan
- Regional priority ..... Regional distribution plan

Management Strategies

- Construction costs ]
- Manpower development ] ..... Expenditure management
- Operating expenditure ]
- Operating revenue ..... Revenue management
- Fund source ..... Fund plan

Technical Development Strategies

- Network configuration ..... Network development plan
- Automatization ]
- Digitalization ] ..... Facility modernization plan
- Backbone transmission system ..... Backbone transmission system development plan

The investment strategies are studied from the national development viewpoint. The technical and management strategies are studied from the PERUMPEL management viewpoint.

An optimal combination of the supply plan, regional capacity distribution plan, expenditure management, revenue management and fund plan is determined by evaluating the financial results of the strategies simulation, of which flow is shown in Figure 1.

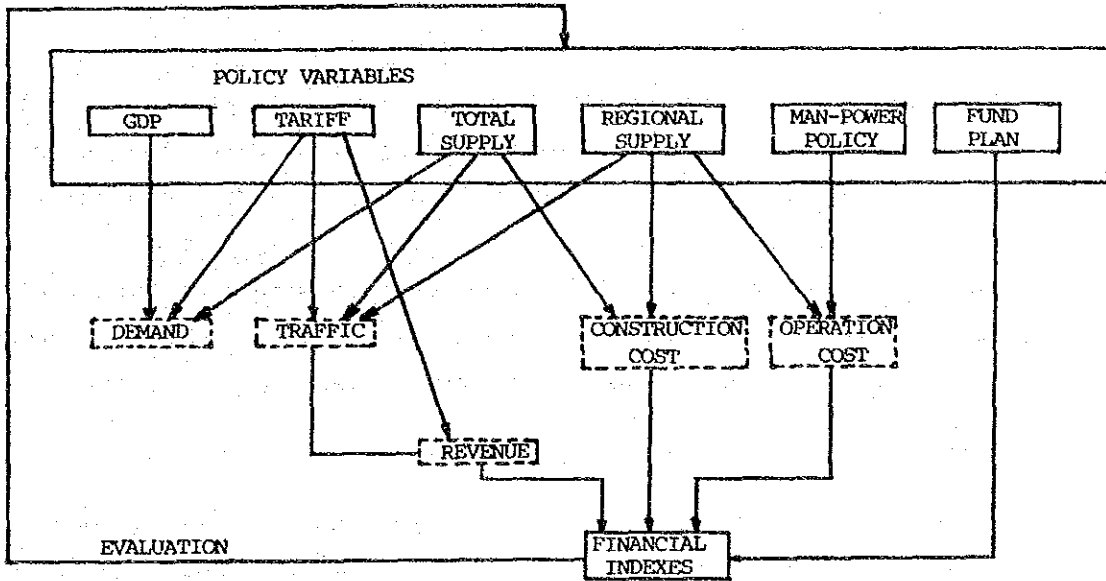

Figure 1 Strategy Simulation Flow

### 3. The Current State of Telecommunications Services

#### (1) The Current State of Services

An analysis was made to examine the current state of the telecommunications services in Indonesia in comparison with other countries. The study result shows that the telephone, telegraph and telex services in Indonesia are below the average level of the services in other ASEAN countries. Even in comparison with India whose GDP per capita is one half of that of Indonesia, the telephone density of Indonesia (0.3/100 persons) is lower than that of India (0.4/100 persons).

On the other hand, some of new services such as data communication service and land mobile telephone service have already been introduced in large cities and therefore Indonesia ranks high in this field among the ASEAN countries.

Another analysis was made to examine development efforts during the past fifteen years and PELITA-IV. Under PELITA-IV, the service level is planned to be twice higher than the level at the end of PELITA-III, with a view to dramatically upgrading the service of which development level has been very low during the past fifteen years.

#### (2) The Current State of PERUMTEL Management

A comparison was made with respect to economic indexes and management indexes among nine countries. It has been found that there exist many problems in service management in Indonesia. The balanced development of service management can be targeted at the current stage of Malaysia as a reasonable next development stage. (Refer to Figures 2, 3 and 4.) It has also been found that the monthly rental fee in Indonesia is about one third (1/3) of the average level of six countries as shown in Table 1.

Table 1 Telephone Service Fees (US\$ in 1984)

Country	Installation Fee	Monthly Rental Fee	GDP per Capita
Japan	480	10	9,780
Singapore	110	9	7,260
Malaysia	130	10	2,060
Thailand	280	17	830
Philippines	100	14	410
Indonesia	180	3	480

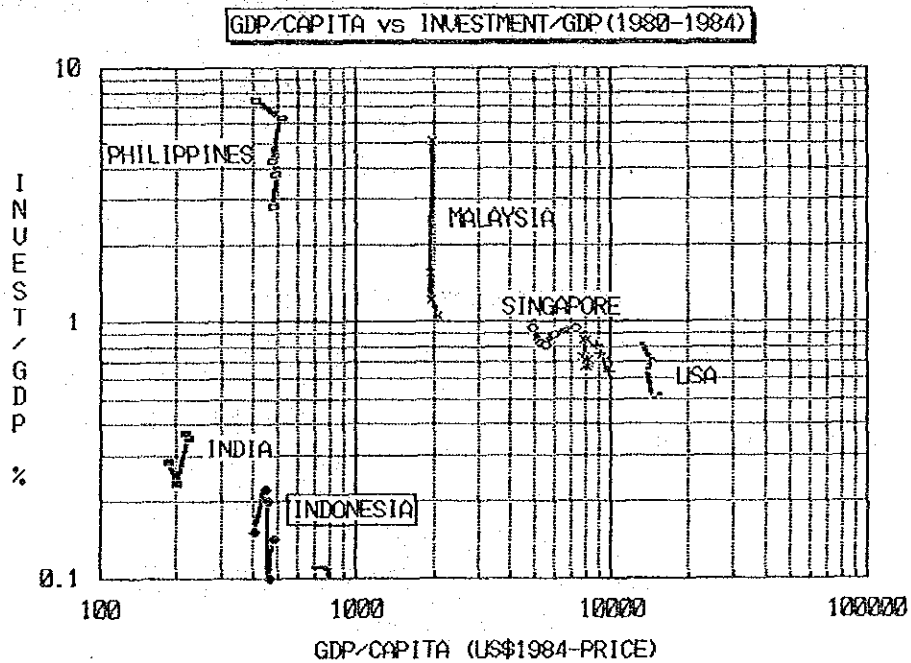

Figure 2 GDP/Capita vs. Telecommunications Investment/GDP

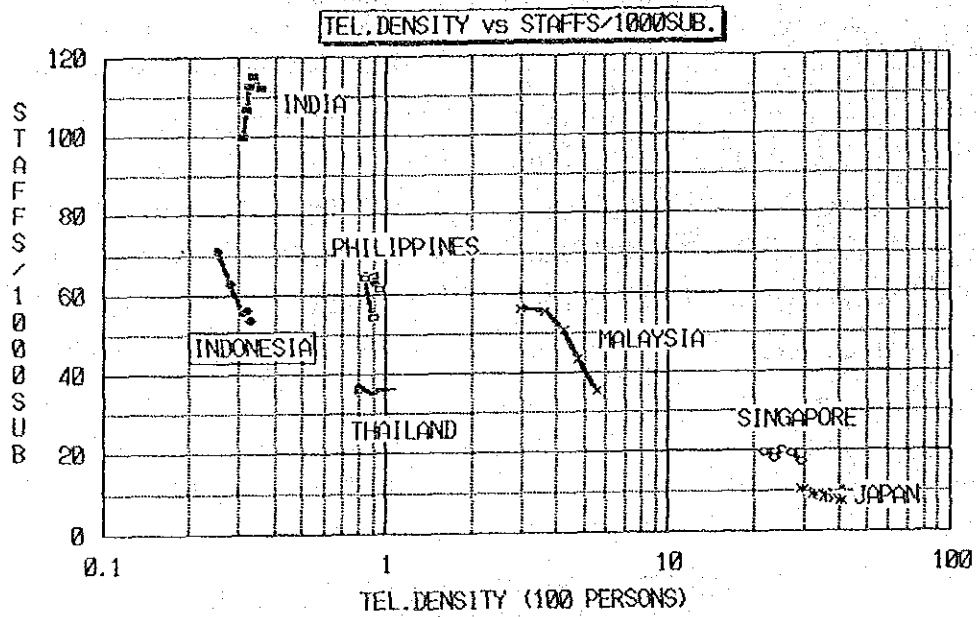

Figure 3 Telephone Density vs. Staffs/1000 Subscribers

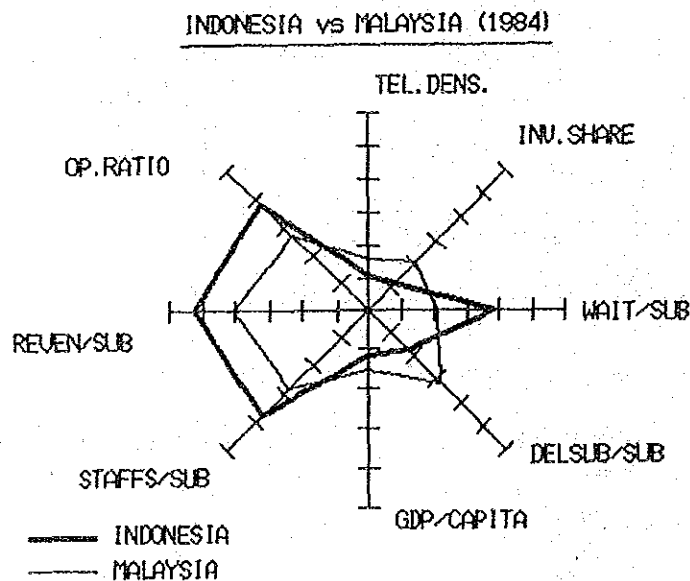

Figure 4 Comparison between Indonesia and Malaysia



#### 4. Telecommunications Services Subscribers Demand Forecasts

##### (1) Telephone Services Subscriber Demands

A forecasting model was developed, based on the data of the twenty countries during the past ten years to predict the number of potential subscribers of the telephone service. The telephone service subscriber demand tends to increase when the supply volume (the number of actual subscribers) increases due to the new demand creating effect. Hence, forecasting was made for the three cases having different supply volumes. Also taken into consideration was the fact that the telephone demand relates to tariff and GDP growth rate.

Table 2 shows the telephone demand forecasts made for three cases, i.e., Plan 1, Plan 2 and Plan 3, on an assumption that the tariff system is the same as the present one and the GDP growth rate is 5%.

Table 2 Telephone Service Demands in Indonesia

(Unit: 1000 L.U.)

Supply Plan	Item	Year			
		1989	1994	1999	2004
Plan 1	Telephone Demand	2,330	3,709	5,496	7,633
	Supply Volume	1,250	2,100	3,200	4,500
Plan 2	Telephone Demand	2,584	4,431	6,930	9,872
	Supply Volume	1,450	2,650	4,300	6,200
Plan 3	Telephone Demand	2,833	5,074	8,300	12,345
	Supply Volume	1,650	3,150	5,400	8,200

Even in Plan-3, the telephone demand still greatly exceeds the supply volume (the number of actual subscribers).

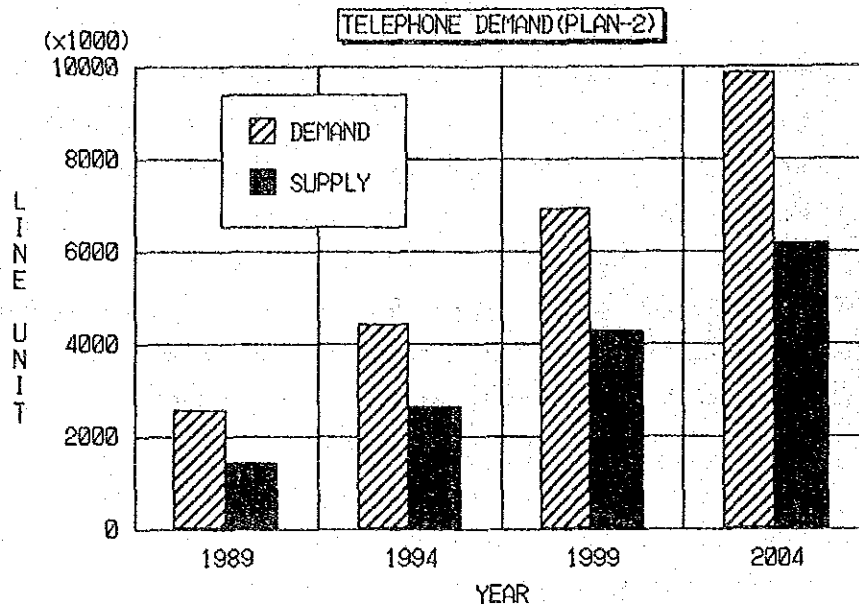

Figure 5 Telephone Service Demand in Indonesia

The sensitivity of demand variation due to variations of GDP growth rate and tariff system is not so high as follows:

- 1) GDP growth rate = 5% to 3%: Demand Change = about 6% down.
- 2) Installation fee = 20% up : Demand Change = about 3% down.

**(2) Non-Telephone Services Subscriber Demands**

The forecasted potential number of subscribers for each non-telephone service category is as shown in Table 3, when capacity expansion of the telephone service is carried out according to the Supply Plan 2 with the 5% GDP growth rate.

Table 3 Non-Telephone Services Demand in Indonesia

(Unit: L.U.)

Service Category	1989	1994	1999	2004
Telex	25,000	39,000	60,000	84,000
Data Communication	750	2,100	4,400	7,800
Facsimile	7,000	27,000	65,000	124,000
Radio Paging	55,000	101,000	163,000	236,000
Land-Mobile Telephone	7,000	10,000	12,000	15,000

It is assumed that the telex service subscribers will be partially switched to the data communications service subscribers and the facsimile service subscribers.

## 5. Telecommunications Traffic Forecasts

### (1) Telephone Service Traffic

The total volume of the nationwide toll telephone service traffic flow in the case of Supply Plan 1 and Supply Plan 2 was estimated as follows:

Table 4. Toll Telephone Service Traffic in Indonesia

Supply Plan	Item	1989	1994	1999	2004
Plan 1	Subscribers (x1000)	990	2,100	3,200	4,500
	Total Traffic (Erl)	10,100	18,200	29,200	42,900
	Traffic/Subs (mErl)	8.1	8.7	9.1	9.5
Plan 2	Subscribers (x1000)	1,130	2,650	4,300	6,200
	Total Traffic (Erl)	12,000	23,600	40,800	61,600
	Traffic/Subs (mErl)	8.3	8.9	9.5	9.9

Most of the current telephone service customers are business customers in Indonesia. This trend seems to continue for a while. This indicates that traffic per subscriber still tends to increase as the number of subscribers increases.

### (2) Telegraph Service Traffic

Telegraph service traffic in Indonesia is still increasing. Traffic in 1994 was estimated to be 6.5 telegrams/100 persons and that in 2004, 8 telegrams/100 persons.

### (3) Telex Service Traffic

The nationwide telex service traffic is forecasted to increase by 7% per year. The traffic per subscribers, however, is forecasted to decrease to 39,800 pulses/year in 1994 from 57,910 pulses/year in 1984.

## 6. Investment Strategies

### (1) Telephone Service Supply Plan

By examining a standard capacity size of the telephone services in many countries of the world in relation to per capita GDP, a statistical line which shows an average capacity size of the telephone service for a given level of GDP per capita was estimated for the purpose of setting target levels of development in Indonesia. Figure 6 shows the statistical line and the position of Indonesia.

According to the examination, the existing supply volume of the telephone service seems well below the average for the given level of GDP in Indonesia. Therefore, a reasonable development objective should be "to catch up with the ASEAN countries standard by the year 2004".

In view of the above reason, two supply plans according to the possible GDP growth rates in the year 2004 are proposed in Table 5 (Proposal #1).

Table 5 Telephone Supply Targets in 2004

Item	Plan 1	Plan 2
Average GDP growth rate	3%	5%
GDP/Capita growth rate	1%	3%
Target density (per 100 persons)	1.84	2.54
Population estimated (x1000)	244,000	244,000
Proposed No. of subscribers (x1000)	4,500	6,200

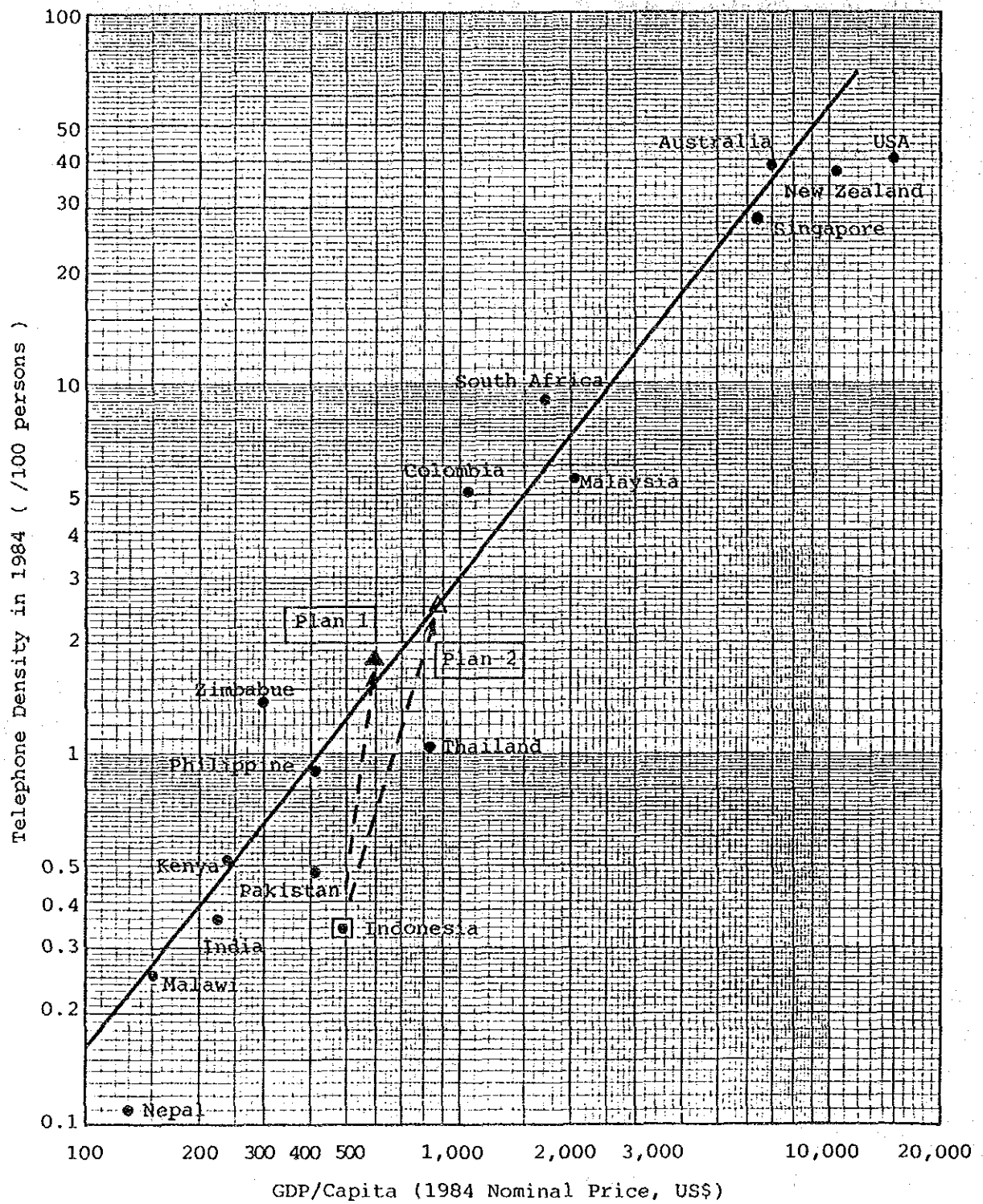

Figure 6 Telephone Density and GDP/Capita of the Countries in the World

Supply plans for every five years which are designed to realize the above targets are proposed in Table 6 and Figure 7.

Table 6 Telephone Service Supply Plans (Nationwide)

(Unit: 1000 L.U.)

Plan	Item	PELITA-IV (1989)	REPELITA-V (1994)	REPELITA-VI (1999)	REPELITA-VII (2004)
1	Telephone Demand	2,330	3,709	5,496	7,633
	Additional Capacity	550	850*	1,100	1,300
	Total Capacity	1,250	2,100	3,200	4,500
	Line Unit/100 persons	0.70	1.06	1.46	1.84
	Capacity/Demand	0.54	0.57	0.58	0.59
2	Telephone Demand	2,584	4,431	6,930	9,872
	Additional Capacity	750	1,200*	1,650	1,900
	Total Capacity	1,450	2,650	4,300	6,200
	Line Unit/100 persons	0.73	1.33	1.96	2.54
	Capacity/Demand	0.56	0.60	0.62	0.63
	Population	179,000	199,000	219,000	244,000

(Note) The figure marked with the \* includes the volume which will be carried over from the PELITA-IV.

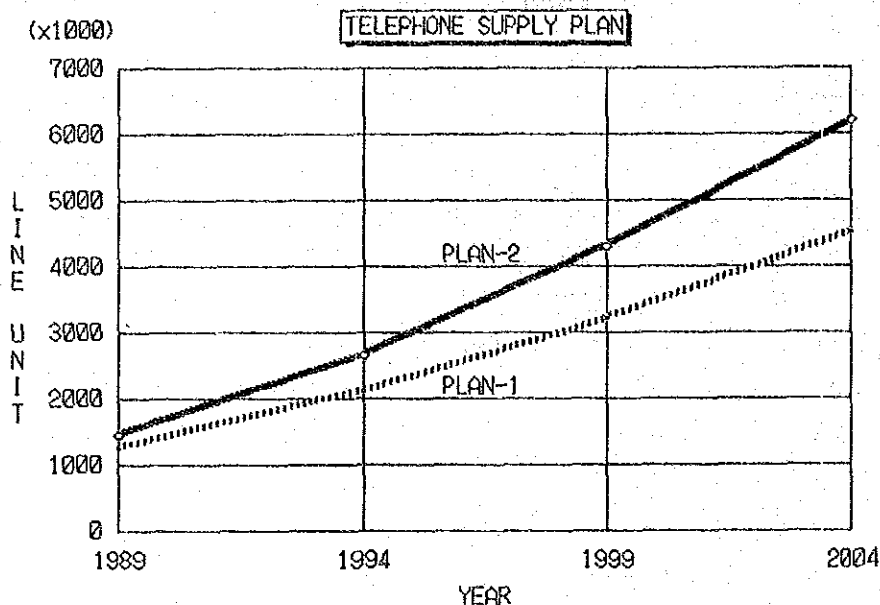

Figure 7 Telephone Service Supply Plans

(2) Non-Telephone Services Supply Plan

The non-telephone services will be provided to satisfy the demands in the urban areas. The supply plan in the case of 5% GDP growth rate is proposed as shown in Table 7 (Proposal #2).

Table 7 Non-Telephone Service Supply Plan (Nationwide)

Service Category	REPELITA-V (1994)	REPELITA-VI (1999)	REPELITA-VII (2004)
Telegraph Office	1,000	2,000	3,500
Telex (L.U.)	31,000	42,000	50,000
Facsimile (L.U.)	26,500	64,500	124,000
Packet Data Comm. (L.U.)	2,100	4,400	7,800
Radio Paging (L.U.)	45,000	80,000	126,000
Land-Mobile Tel. (L.U.)	8,000	10,000	12,000
ISDN	Narrow Band	Narrow Band	Wide Band

For the case of 3% GDP growth, expansion should be scaled down by 20 - 30% of the above proposal.



**(3) Regional Capacity Distribution**

In addition to the Strategy A2 in which regional capacity distribution is carried out in such a way as to maintain, even in the future, the WITELs capacity share realized at the end of PELITA-IV (shown in Figure 8), the following two strategies were considered:

- 1) To improve financial performances through increasing the capacity expansion in the 6 highest profitable regions (WITELs which include Medan, Palembang, Jakarta, Bandung, Semarang, Surabaya) by 20%, and decreasing the capacity expansion in other regions by 20%. (Strategy A1)
- 2) To realize balanced national development through decreasing the capacity expansion in the Jakarta area by 20% and making the telephone density in other regions uniform. (Strategy A3)

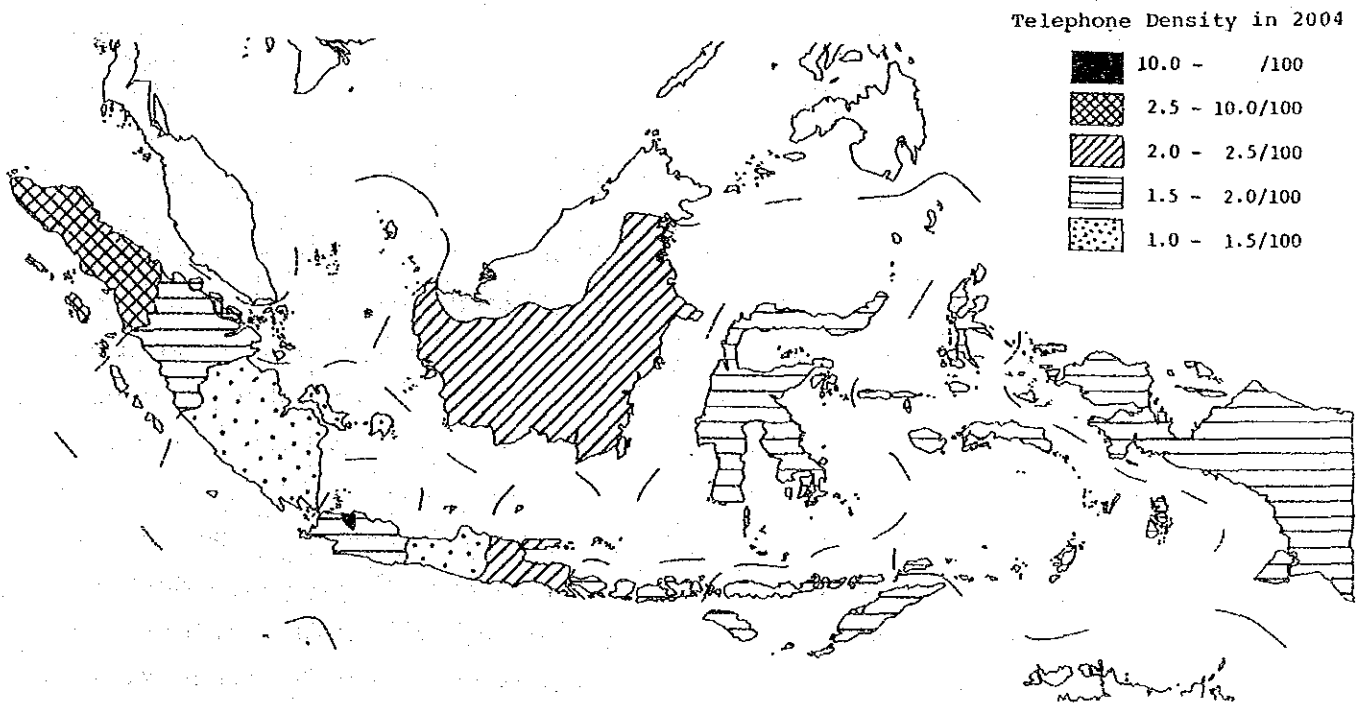

Figure 8 Telephone Supply by WITEL (Strategy A2)

## 7. Management Strategies

### (1) Expenditure Management

As a result of analyzing the asset data of the past ten years, the future construction costs were estimated to be Rp. 4 Million per L.U. in Jakarta, the least expensive area, and Rp. 16 Million per L.U. in Irian Jaya, the most expensive area as shown in Figure 9. The estimated total construction costs for each REPELITA are as follows:

Table 8 Investment Costs of REPELITA-V, VI and VII  
(December 1986 price)

Plan	Item	REPELITA-V	REPELITA-VI	REPELITA-VII
Plan 1 and A2	Telephone Expansion Capacity (1000 L.U.)	850	1,100	1,300
	Total Cost (Billion Rp.)	5,267	6,816	8,055
Plan 2 and A2	Telephone Expansion Capacity (1000 L.U.)	1,200	1,650	1,900
	Total Cost (Billion Rp.)	7,430	10,217	11,765

As a result of analyzing the operation expenditure data of the past five years, it has been found that the O&M costs per subscriber have been increasing, although the number of staffs per subscriber has been decreasing. If this trend continues in the future, the O&M costs per subscriber will be Rp. 1.0 Million in 1994 and Rp. 1.5 Million in 2004. These figures exceed the revenue per subscriber, which will be discussed later. The increasing O&M costs must be controlled by technology development and management efforts by PERUMTEL. One of such efforts was quantified as the Strategy M1 in which the number of staffs per 1,000 L.U. is reduced to 20 and the O&M cost per subscriber is reduced to Rp. 0.4 Million, as shown in Figure 10.

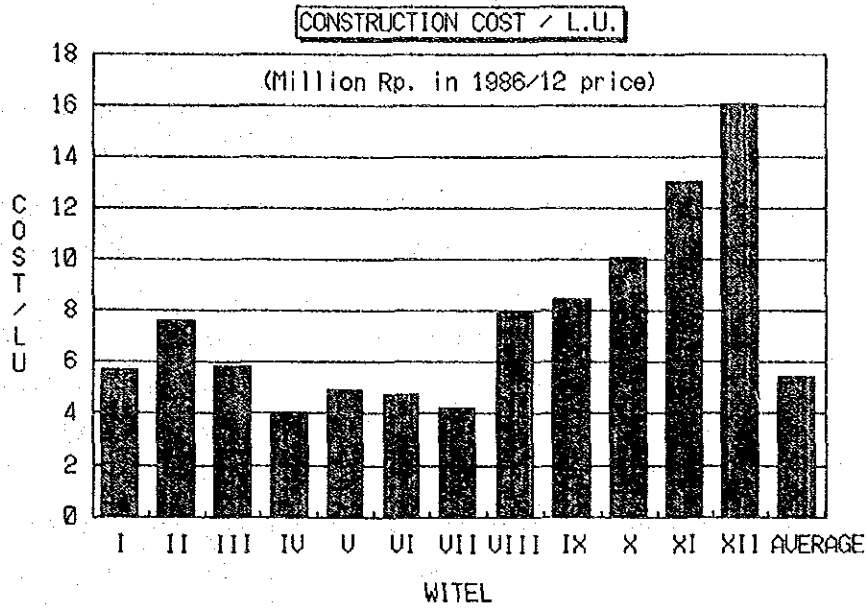

Figure 9 Construction Costs in the WITELs (December 1986 price)

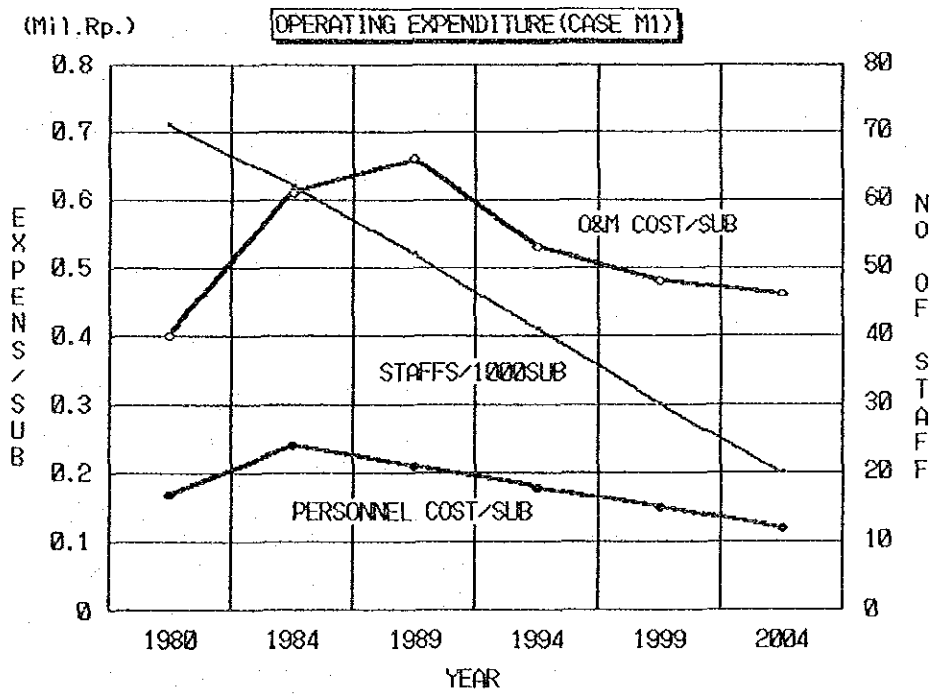

Figure 10 Operating Expenditure Reduction Strategy (M1)

## (2) Revenue Management

The 90% of total revenue of PERUMTEL is currently generated by the telephone service. This trend is expected to continue in the future.

When the telephone density is low and, therefore, the share of the business customers is large, the revenue per subscriber increases as the number of the telephone subscriber increases because traffic per subscriber also increases. The revenue from one telephone subscriber in 1994 is estimated to be Rp. 1.3 Million and that in 2004, Rp. 1.4 Million, in case the current tariff system is maintained.

Since it was found to be quite difficult to improve the PERUMTEL's financial condition without changing the tariff system, some strategies on tariff changes were also considered. For example, the call fee increase from Rp. 75/pulse to Rp. 85/pulse (Strategy T1) will increase revenue by 13%.

## (3) The Results of Strategies Simulation

Several simulation studies were conducted by making several combinations of investment and management strategies. The results were evaluated by financial indexes. As a result, the combinations of the strategies shown in Figure 11 were found feasible.

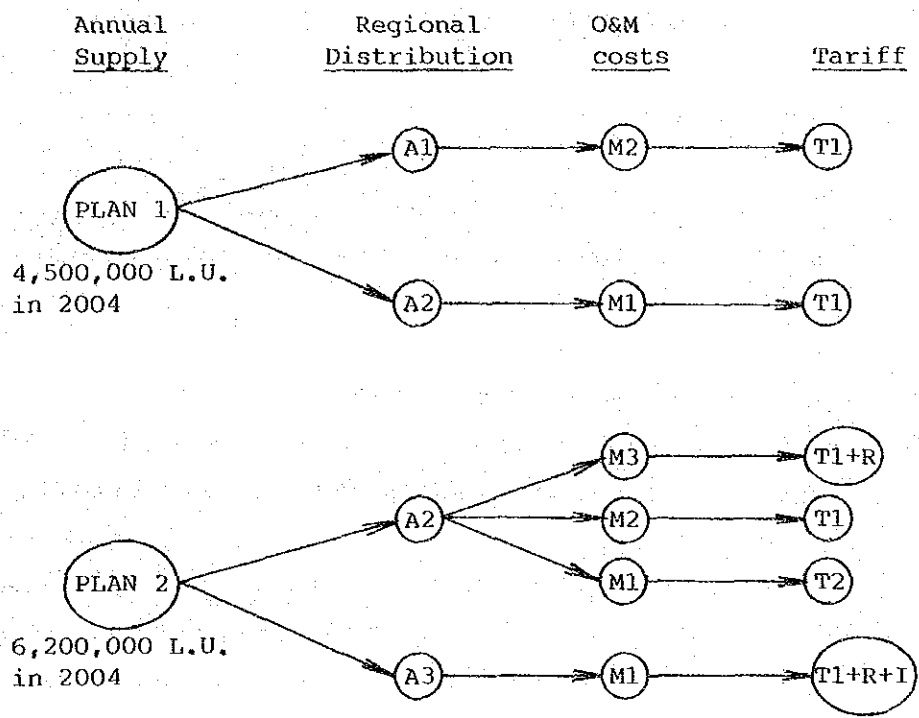

Note

- A1 : Capacity expansion in the six major cities
- A2 : Capacity expansion in line with PELITA-IV capacity expansion plan
- A3 : Equal capacity distribution in all the WITELs except Jakarta
- M1 : 20 staffs/1000 L.U.
- M2 : 30 staffs/1000 L.U.
- M3 : 40 staffs/1000 L.U.
- T1+R+I: Increase of the call, monthly rental, installation fees
- T1+R : Increase of the call and monthly rental fees
- T1 : Increase of the call fee (Rp. 85/pulse)
- T2 : Increase of the call fee during REPELITA-V only  
(Rp. 85/pulse during REPELITA-V)  
(Rp. 75/pulse after REPELITA-V)

Figure 11 Feasible Combinations of Strategies

## 8. Technical Development Strategies

### (1) Network Integration Plan

Figure 12 shows the network integration plan up to the year 2004. This plan was formed on the basis of the following policies (Proposal #3):

- 1) To provide full scale ISDN in 2000.
- 2) Expansion of the existing analog system will be stopped in PELITA-IV. Only digital system will be constructed in and after REPELITA-V.
- 3) Circuit switched data communication service is to be provided by ISDN in large cities, and no dedicated network will be constructed.
- 4) Video communication service is to be provided by leased lines for the time being and switched type service will be provided after the year 2000.

### (2) Facility Modernization Plan

The facilities must be modernized to improve the quality of the services and to establish ISDN. The facility modernization shall be promoted by automatization and digitalization of the system.

The automatization plan is shown in Figure 13. The digitalization plan for switching systems up to the year 2004 is proposed as follows:

Type of Switch	1989	1994	1999	2004
Analog Switch	46%	28%	7%	0%
Digital Switch	54%	72%	93%	100%

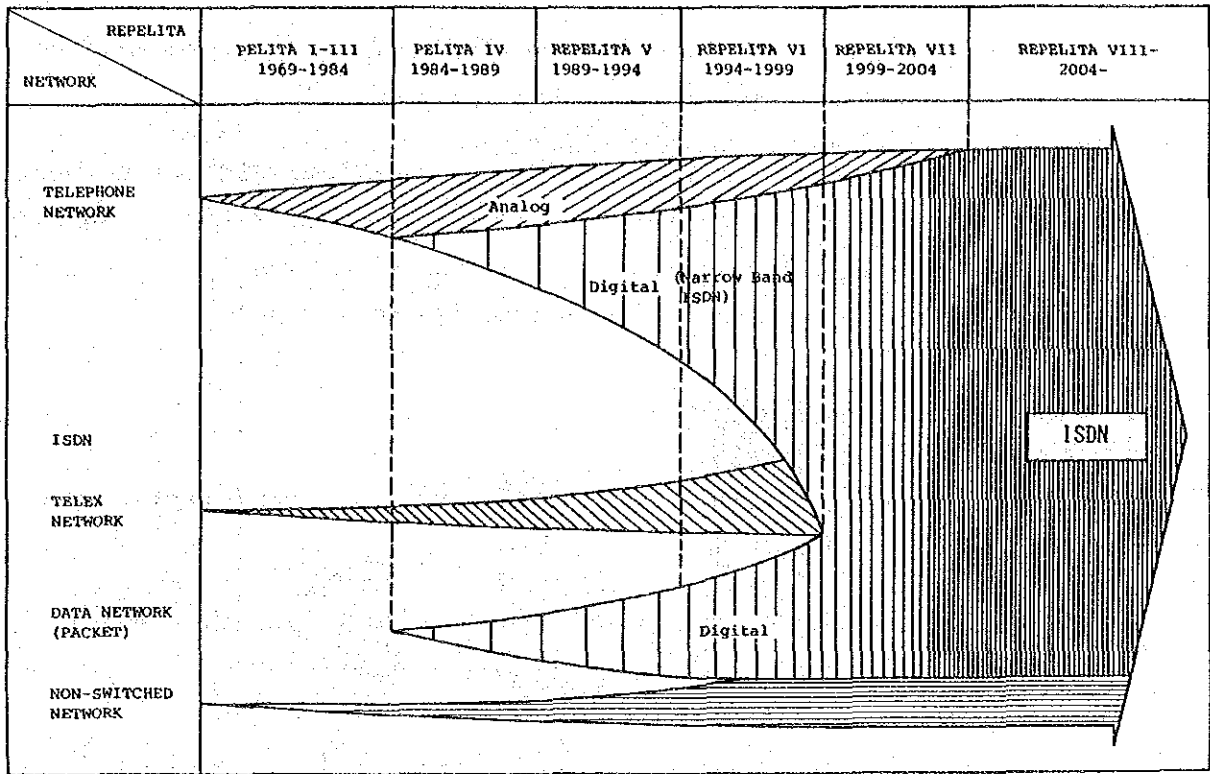

Figure 12 Network Integration Plan

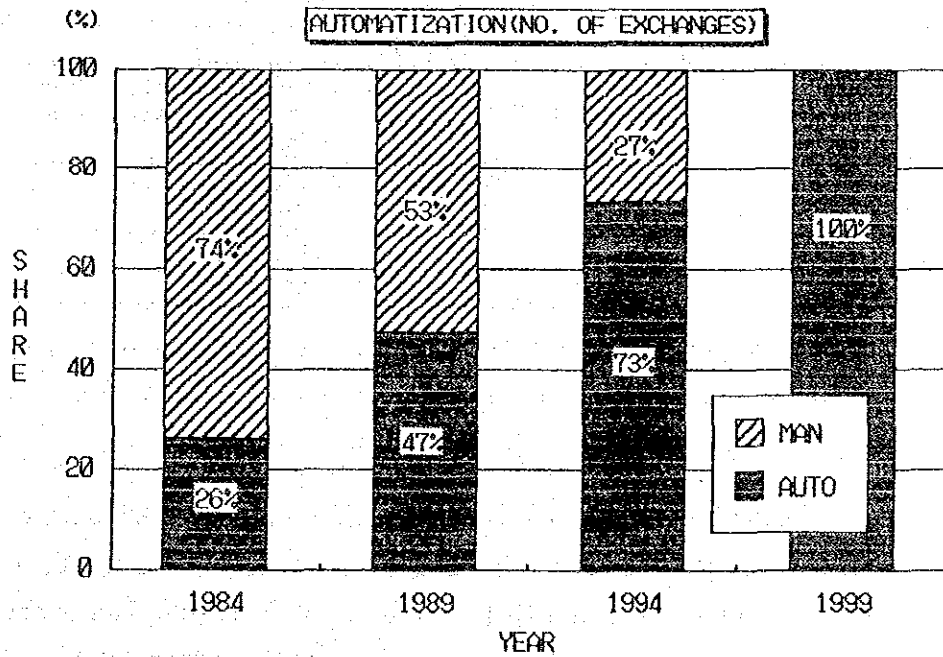

Figure 13 Automatization Plan

Digitalization of transmission systems also has to be promoted together with digitalization of switching systems.

For the urban areas with automatized analog system, digital network will be overlaid to expand the network (Overlay Method). For the rural areas with only manual system, automatization for each unit area will be promoted by digital system (Islands Method).

### (3) Backbone Transmission System

The basic principles for backbone transmission system expansion are as follows:

- 1) To increase the reliability of the network, two-route system by terrestrial and satellite transmission shall be employed to link the Secondary Centers.
- 2) TV program transmission through terrestrial system to all the Province capitals shall be available at the earliest possible time.
- 3) Two terrestrial transmission routes shall be provided for links having high traffic flow.
- 4) Ring-belt structure by terrestrial routes (terrestrial transmission route which resembles a belt made by connected loops) for links having high traffic flow that connects islands, and cities within island shall be employed to make detouring possible in case of emergency.

It is proposed by costs analysis that the toll circuits shall be mainly distributed to satellite systems for long distance (more than 1500 - 2750 km) transmission and to terrestrial systems for short distance (less than 1500 - 2750 km) transmission.

Figure 14 shows the toll circuits distribution between satellite and terrestrial systems within the capacity limit of satellite systems. As can be seen from Figure 14, the share of terrestrial systems in handling traffic needs to be gradually expanded after PELITA-IV.



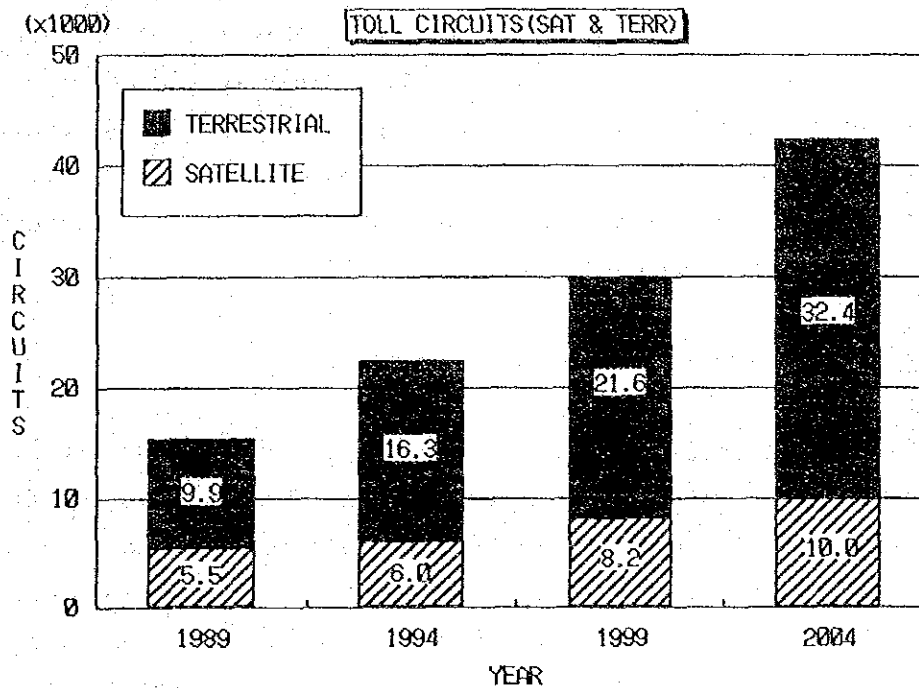

Figure 14 Distribution Plan of Toll Circuits between Terrestrial and Satellite Systems

## 9. Development Scenarios

### 9-1 Optimum Development Scenarios

The four optimum development scenarios based on the simulation results and the technical development strategies discussed in Section 8 are proposed as follows (Proposal #4):

#### (1) Scenario 1 (Optimum Scenario on Plan 1)

This is the optimum scenario when the GDP growth rate is 3% per year. The capacity will be expanded in such a way as to maintain the regional capacity distribution pattern realized at the end of PELITA-IV. The number of staff personnel must be reduced to 20 staffs/1000 L.U. by the year 2004, which will enable to decrease the O&M costs remarkably. The call fee will be increased to Rp. 85/pulse to increase the revenue.

(2) Scenario 2 (Alternative Scenario on Plan 1)

This is the second best alternative scenario for 3% GDP annual growth rate. The capacity will be expanded mainly in six major cities. In so doing, the number of staff personnel will be reduced to 30 staffs/1000 L.U. by the year 2004. Such profitability improvement efforts by PERUMTEL will be assisted by a revenue increase through the call fee increase to Rp. 85/pulse.

(3) Scenario 3 (Optimum Scenario on Plan 2)

This is the optimum scenario when if the GDP growth rate is 5% per year. The capacity will be expanded by the same distribution pattern realized at the end of PELITA-IV. The number of staff personnel will be reduced to 20 staffs/1000 L.U. by the year 2004 in order to reduce the O&M costs. The call fee will be increased to Rp. 85/pulse only during the period of REPELITA-V but can be decreased to the present level of Rp. 75/pulse by the year 2004.

(4) Scenario 4 (Alternative Scenario on Plan 2)

This is the second best alternative scenario for 5% GDP annual growth rate, to be applied when the number of staff personnel is reduced to only 30 staffs/1000 L.U. by the year 2004. The call fee must be increased to Rp. 85/pulse and will be kept at that level until the year 2004.

Table 9 shows the details of Scenario-1 and Table 10, Scenario-3. Figure 15 and Figure 16 show respective annual variations of revenues and expenditures.

Table 9 Development Scenario-1 (Optimum Scenario on Plan-1)

Strategy Item	REPELITA-V (1989-1994)	REPELITA-VI (1994-1999)	REPELITA-VII (1999-2004)
Investment Strategy	<p>Service categories: Mainly telephone/telegraph Social/Business</p> <p>User categories: Social/Business</p> <p>Network coverage: To all Kabupaten capitals</p> <p>Supply volume: 850,000/2,100,000 L.U.</p> <p>Regional distribution: Share of PELITA-IV</p>	<p>(Same as REPELITA-V)</p> <p>Social/Business</p> <p>To major Kecamatan capitals</p> <p>1,100,000/3,200,000 L.U.</p> <p>(Same as REPELITA-V)</p>	<p>Introduction of ISDN</p> <p>Social/Business/Residence</p> <p>To all Desa centers</p> <p>1,300,000/4,500,000 L.U.</p> <p>(Same as REPELITA-V)</p>
Management Strategy	<p>O&amp;M costs/subscriber Staffs/1000 L.U.: Million Rp. 0.52 41 staffs</p> <p>Tariff System:</p> <p>Installation fee: No change</p> <p>Monthly rental fee: No change</p> <p>Call fee: Rp. 85/pulse</p> <p>Government equity: 10% of required fund</p> <p>External fund: 50% of required fund</p>	<p>Million Rp. 0.44</p> <p>30 staffs</p> <p>No change</p> <p>No change</p> <p>Rp. 85/pulse</p> <p>10% of required fund</p> <p>15% of required fund</p>	<p>Million Rp. 0.40</p> <p>20 staffs</p> <p>No change</p> <p>No change</p> <p>Rp. 85/pulse</p> <p>Not required</p> <p>15% of required fund</p>
Technical Development Strategy	<p>Network integration: Independent</p> <p>Automization &amp; Digitalization: Up to middle cities</p> <p>Terrestrial share: 73%</p> <p>Satellite share: 27%</p>	<p>Integrate Telex to Telephone</p> <p>Up to small cities</p> <p>72%</p> <p>28%</p>	<p>Full integration</p> <p>Full automatization &amp; digitalization</p> <p>76%</p> <p>24%</p>

Note: The supply volume shows Additional telephone capacity/Total telephone capacity. The December 1986 base price is used for costs and fees.

Table 10 Development Scenario-3 (Optimum Scenario on Plan-2)

Strategy Item	REPELITA-V (1989-1994)	REPELITA-VI (1994-1999)	REPELITA-VII (1999-2004)
Investment Strategy	<p>Service categories: Mainly telephone/telegraph Social/Business</p> <p>User categories: To all Kabupaten capitals</p> <p>Network coverage: 1,200,000/2,650,000 L.U.</p> <p>Supply volume: Share of PELITA-IV</p> <p>Regional distribution: (Same as REPELITA-V)</p>	<p>(Same as REPELITA-V)</p> <p>Social/Business</p> <p>To major Kecamatan capitals</p> <p>1,650,000/4,300,000 L.U.</p> <p>(Same as REPELITA-V)</p>	<p>Introduction of ISDN</p> <p>Social/Business/Residence</p> <p>To all Desa centers</p> <p>1,900,000/6,200,000 L.U.</p> <p>(Same as REPELITA-V)</p>
O&M costs/subscriber Staffs/1000 L.U.	Million Rp. 0.53 41 staffs	Million Rp. 0.48 30 staffs	Million Rp. 0.46 20 staffs
Tariff System:			
Installation fee	No change	No change	No change
Monthly rental fee	No change	No change	No change
Call fee	Rp. 85/pulse	Rp. 80/pulse	Rp. 75/pulse
Government equity	10% of required fund	10% of required fund	Not required
External fund	60% of required fund	45% of required fund	30% of required fund
Technical Development Strategy	<p>Network integration: Independent</p> <p>Automation &amp; Digitalization: Up to middle cities</p> <p>Terrestrial share: 73%</p> <p>Satellite share: 27%</p>	<p>Integrate Telex to Telephone</p> <p>Full automation &amp; digitalization: 72%</p> <p>72%</p> <p>28%</p>	<p>Full integration</p> <p>(Same as REPELITA-VI)</p> <p>76%</p> <p>24%</p>

Note: The supply volume shows Additional telephone capacity/Total telephone capacity. The December 1986 base price is used for costs and fees.

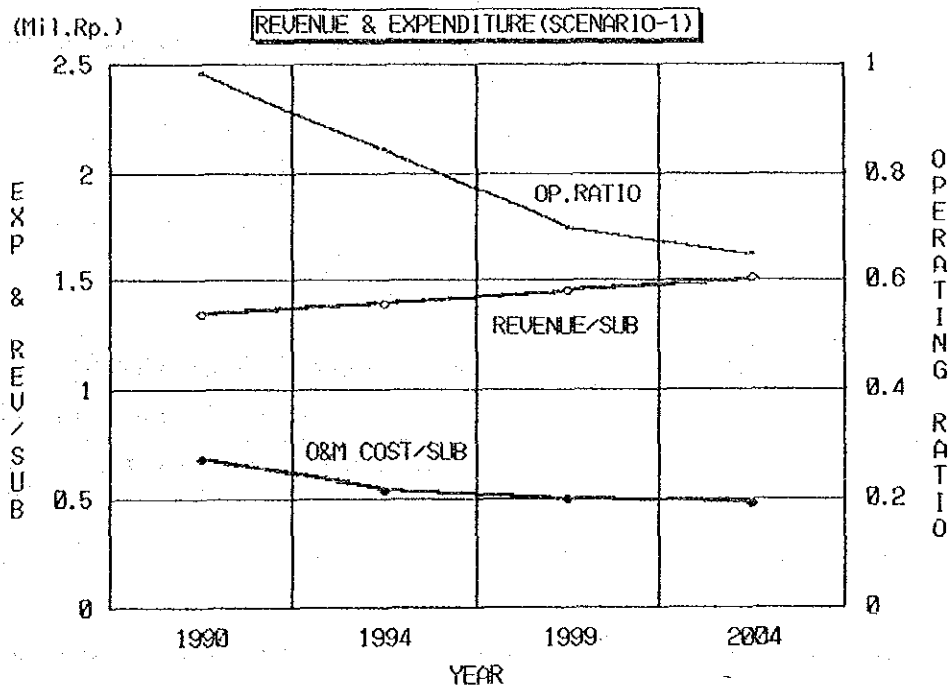

Figure 15 Revenue/Expenditure Forecast of Scenario-1

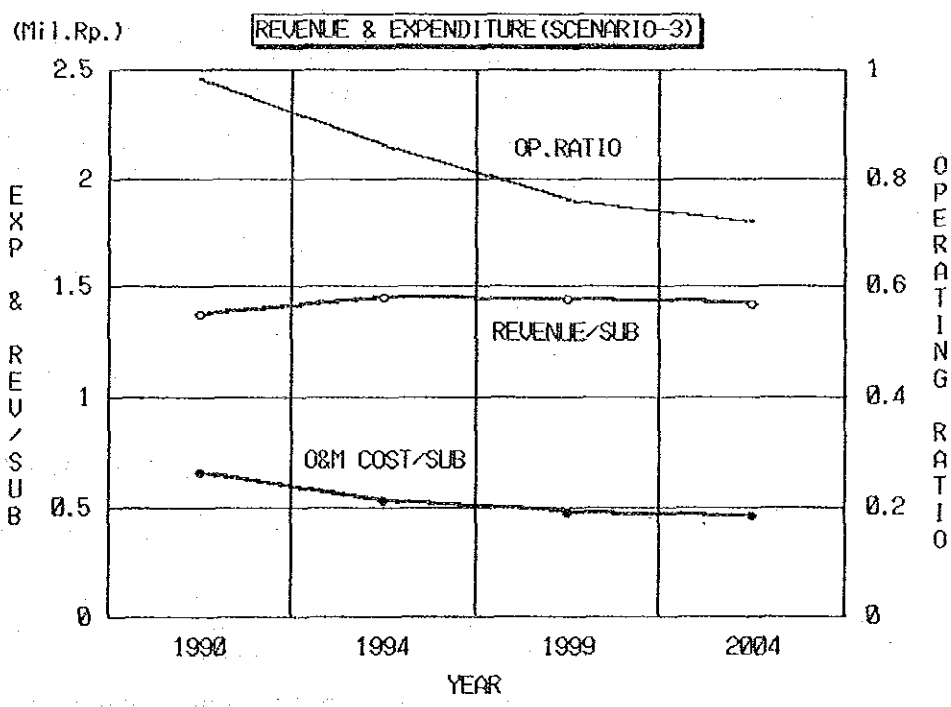

Figure 16 Revenue/Expenditure Forecast of Scenario-3

## 10. Facility Expansion Plan

The following is a facility expansion plan in the case of the 5% GDP growth rate:

### (1) Network Plan

#### 1) Telephone Network

TCs and SCs can be integrated into one hierarchy in 2004 to achieve efficient utilization of the long distance transmission network in order to meet the toll traffic increase.

#### 2) Telex Network

The network will be integrated into the digital telephone network during REPELITA-VI.

#### 3) Packet Switched Data Communication Network

The SKDP packet switched data communication network will be expanded to accommodate the increased demand. The existing PACKSATNET system will be integrated into the packet switched data communication network.

### (2) Telephone Service Facility

#### 1) Capacity

The capacity will be expanded to 2,650,000 in 1994, 4,300,000 in 1999, and 6,200,000 in 2004.

#### 2) Telephone Exchanges

The number of telephone exchanges will be expanded to 836 in 1994, 969 in 1999 and 1,132 in 2004.

### (3) Non-Telephone Service Facilities

#### 1) Telegraph Service Facility

Quick delivery service will be available in all the Kecamatan capitals by 1994 and in all Desa by 2004. The required number of telegraph offices will be 1,000 in 1994, 2,000 in 1999 and 3,500 in 2004.

#### 2) Other Non-Telephone Service Facilities

Category	REPELITA-V	REPELITA-VI	REPELITA-VII
Telex	32,000 L.U.	Integrated into the telephone network	Integrated into the telephone network
Packet Data	2,100 L.U.	4,400 L.U.	7,800 L.U.
Radio Paging	44,000 L.U.	80,000 L.U.	126,000 L.U.
	Jakarta Surabaya Bandung Medang Semarang	Ujung Pandang Palembang Malang  (new introduction)	Yogyakarta Banjar Masin Denpasar Cirebon (new introduction)
Land-Mobile Telephone	14,500 L.U.	15,500 L.U.	16,000 L.U.
	Jakarta Surabaya Bandung Semarang	the same cities as those of REPELITA-V.	the same cities as those of REPELITA-V. plus Medan (new introduction)
ISDN	Narrow Band	Narrow Band	Wide Band
	Jakarta Surabaya Bandung Medan	the same cities as those of REPELITA-V.	Jakarta Surabaya Bandung Medan

Note: For telex and land-mobile telephone services, the capacity is not same as Table 7 considering the existing capacity.

#### (4) Long Distance Transmission Facility

##### 1) Terrestrial Transmission System

Figure 17 shows a proposed long-term backbone terrestrial transmission system plan (Proposal #5). Section 10-3-1 of this report discusses three expansion plans of backbone terrestrial transmission systems for every five years up to the year 2004.

##### 2) Satellite Transmission System

As a result of examining satellites launching plans and earth stations construction plans, about 250 earth stations are proposed to be needed in 2004 as shown in Figure 18 (Proposal #6).

#### (5) Manpower Training and Maintenance Center Facility

##### 1) Manpower Training Facility

When the telephone service capacity is expanded to 6,200,000 L.U. by 2004, and the staffing rate is reduced to 20 staffs per 1000 subscribers, one third (1/3) of the current rate, 84,000 new staffs must be employed in fifteen years.

That is,

$$84,000 \text{ staffs} = (6,200,000 \text{ L.U.} \times \frac{20 \text{ staffs}}{1000}) - 40,000 \text{ staffs}$$

(new) (present)

This figure implies that 5,000 - 6,000 new staffs must be trained every year. Therefore, the education and training facilities of PERUMTEL must be expanded.



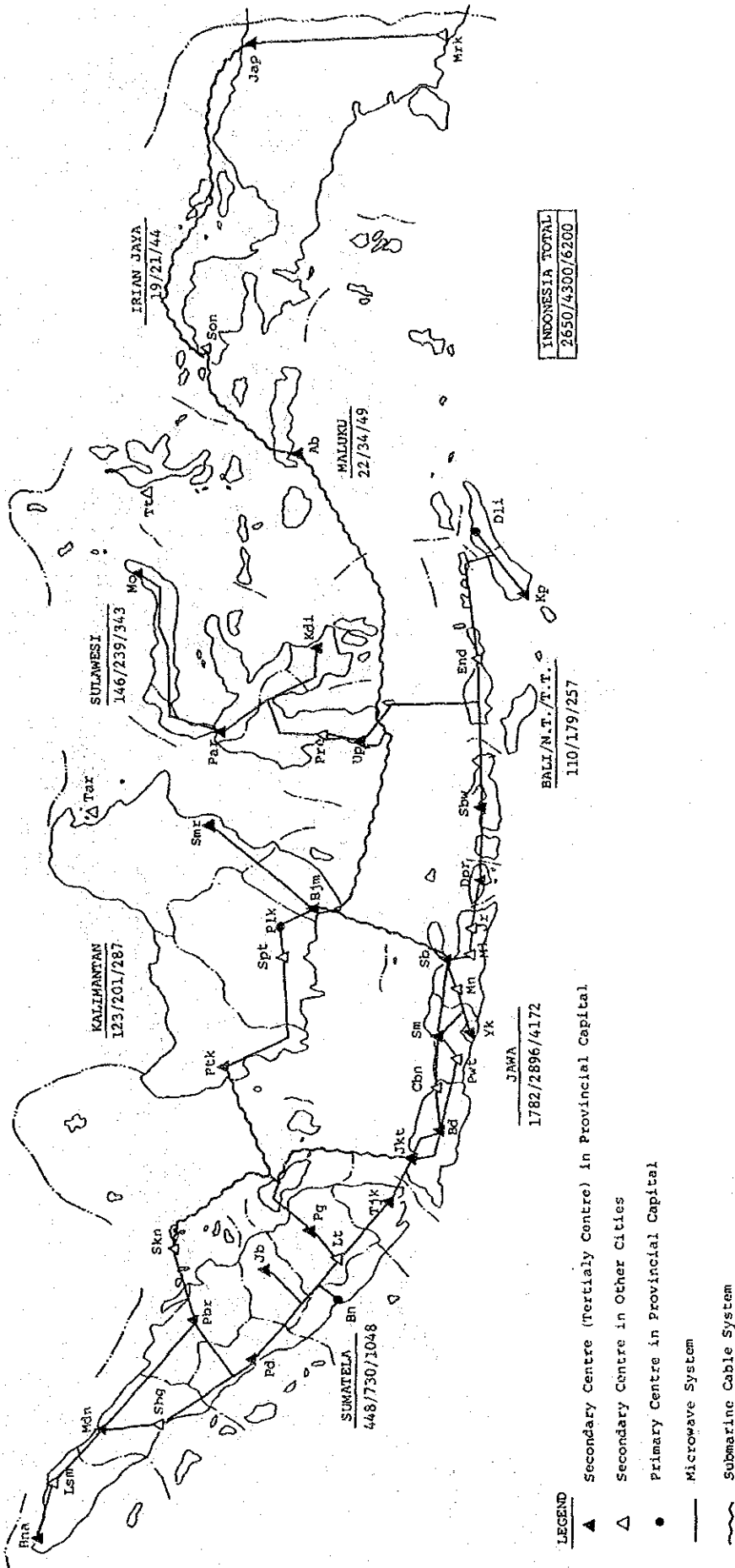

87/141/205 No. of Subscribers in 1994/1999/2004 (x1000)

Figure 17 Backbone Terrestrial Transmission Link in The Year 2004

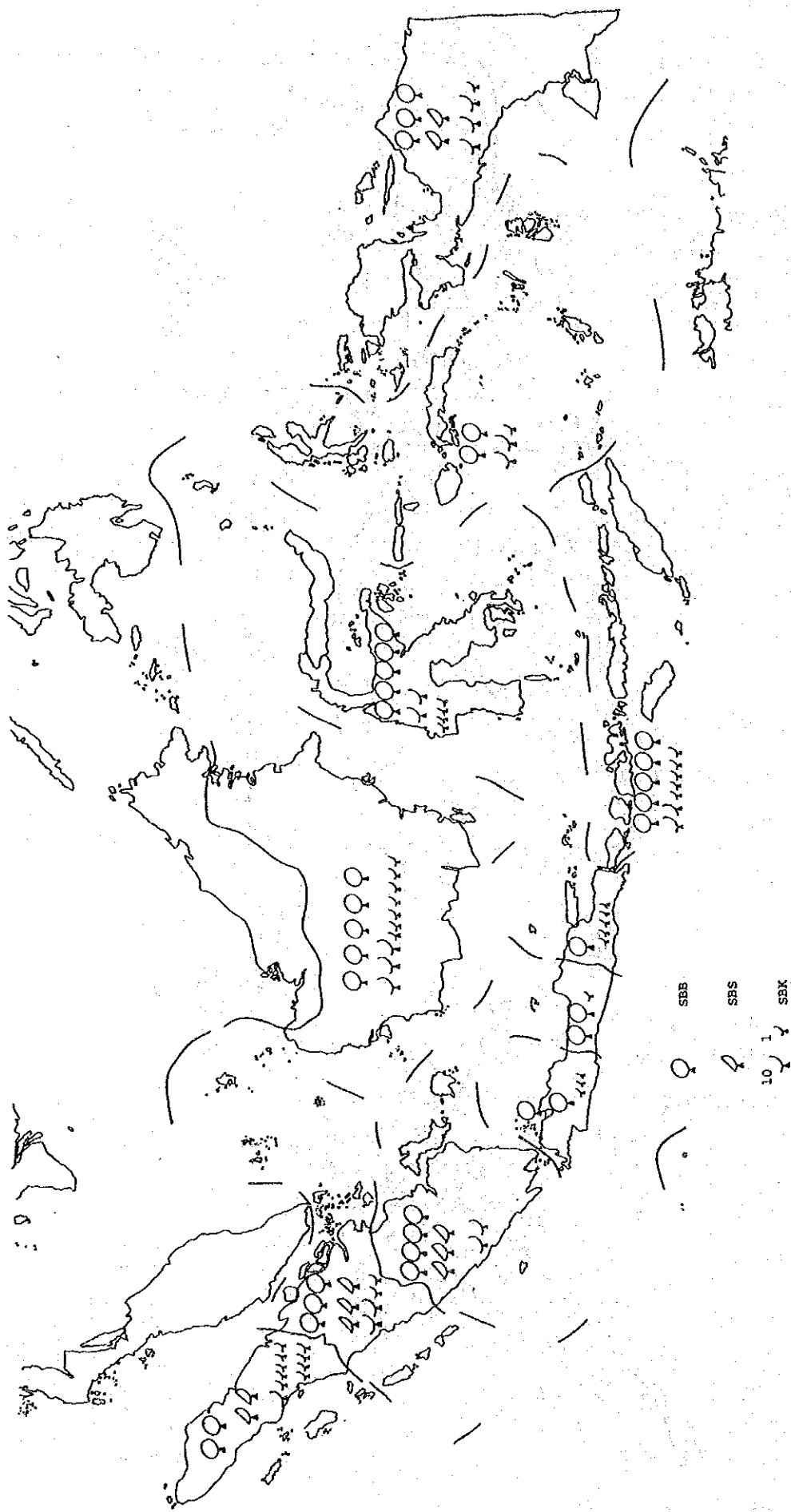

Figure 18 The Number of Earth Stations in The Year 2004

2) Maintenance Center Facility

Five outside plant maintenance centers are planned to be constructed in Jakarta.

3) Network Management System

The local cable network management centers and the toll network management centers will be established for all WITELs in REPELITA-V and REPELITA-VI, respectively.

(6) Project Implementation Program

The projects for realizing REPELITA-V and REPELITA-VI were formulated according to the following policies:

- 1) The package project system by area will be adopted for the local telephone networks in regions outside Jakarta, by integrating switching system, local cable network and junction network projects, instead of currently adopted separate project system by technical fields. By applying this package project system, well balanced total telephone network can be realized.
- 2) The separate project system by technical fields will be adopted for the toll switching system, long distance transmission system and radio subscriber system projects, because each system employs different technologies and, besides, each system requires well coordinated interface condition which should not be dealt with separately by area.
- 3) Non-telephone service facilities will be provided by independent projects on a service category basis because the project size is small and the different technologies are to be used.

The main projects for REPELITA-V and REPELITA-VI are listed in Table 11 through Table 14.

Table 11 Main Project in REPELITA-V (1/2)

Code	Project Title	Project Size	Work Period	Pri- ority
<u>Greater Jakarta Local Network</u>				
V- 1	Local Switching System Project (Phase 1)	150,000 L.U.	3 years	1
V- 2	Local Switching System Project (Phase 2)	175,000 L.U.	"	2
V- 3	Local Cable Network Project (Phase 1)	150,000 L.U.	"	1
V- 4	Local Cable Network Project (Phase 2)	175,000 L.U.	"	2
V- 5	Junction Network Project		"	1
<u>Local Telephone Network outside Jakarta</u>				
V- 6	Sumatera Kotamadya Project I (WITEL I)	71,000 L.U.	5 years	1
V- 7	Sumatera Kotamadya Project II (WITEL II, III)	55,000 L.U.	"	2
V- 8	Sumatera Kabupaten Project (WITEL I - III)	43,000 L.U.	"	3
V- 9	Jawa Kotamadya Project I (WITEL V)	77,000 L.U.	"	1
V-10	Jawa Kotamadya Project II (WITEL VI)	63,000 L.U.	"	2
V-11	Jawa Kotamadya Project III (WITEL VII)	122,000 L.U.	"	1
V-12	Jawa Kabupaten Project (WITEL V - VII)	87,000 L.U.	"	2
V-13	Bali/Nusa Tenggara/Timor Timur Project (WITEL VIII)	41,000 L.U.	"	3
V-14	Kalimantan/Sulawesi Kotamadya Project (WITEL IX, X)	71,000 L.U.	"	2
V-15	Kalimantan/Sulawesi Kabupaten Project (WITEL IX, X)	30,000 L.U.	"	3
V-16	Maluku/Irian Jaya Project (WITEL XI, XII)	15,000 L.U.	"	3
<u>Toll Switching System</u>				
V-17	Expansion of Digital Toll Switching System	30,000 CCT	5 years	1
<u>Terrestrial Transmission</u>				
V-18	Trans Sulawesi Digital M/W System	2,300 km	5 years	1
V-19	Bjm-UP Optical Fiber Submarine Cable (+M/W150 km)	700 km	3 years	1
V-20	Trans Kalimantan Digital M/W System	1,050 km	4 years	2
V-21	East Indonesia Digital M/W System	1,900 km	"	2
V-22	Mdn-Bna Digital M/W System	550 km	3 years	2
V-23	Bpp-Smr Digital M/W System	200 km	2 years	3
V-24	Up-Ab Optical Fiber Submarine Cable (+M/W200 km)	1,100 km	3 years	3
V-25	Jawa Digital Spur M/W System	750 km	4 years	1
V-26	Sumatera Digital Spur M/W System	350 km	"	2
V-27	Subscriber Radio System (Phase 1)	5,000 L.U.	"	2
V-28	Subscriber Radio System (Phase 2)	5,000 L.U.	"	3

Table 12 Main Project in REPELITA-V (2/2)

Code	Project Title	Project Size	Work Period	Pri- ority
<u>Satellite Transmission System</u>				
V-29	PALAPA C1 Launching	1 Sat.	5 years	1
V-30	TDMA Satellite Link Expansion	up to 4,800 ch	"	2
V-31	50 Small Earth Stations (SBK)	50 SBK	"	3
V-32	Relocation of 31 Smaller Earth Stations	31 SBK	"	3
<u>Others</u>				
V-33	Expansion of Packet Data Communication System	up to 2,100 terminals	3 years	1
V-34	Expansion of Radio Paging System	up to 45,000 L.U.	5 years	2
V-35	Expansion of Land-Mobile Telephone System	up to 14,500 L.U.	3 years	3
V-36	ISDN Pilot Project	1 system	"	2
V-37	Provision of Coin Telephone Sets	47,000 sets	"	1
V-38	Local Cable Maintenance Center Project	5 centers	4 years	1
V-39	Network Management Center Project (Cable)	12 centers	"	1
V-40	Education & Training Center Project	expansion	3 years	1

Table 13 Main Project in REPELITA-VI (1/2)

Code	Project Title	Project Size	Work Period	Pri- ority
<u>Greater Jakarta Local Network</u>				
VI- 1	Local Switching System Project (Phase 1)	250,000 L.U.	3 years	1
VI- 2	Local Switching System Project (Phase 2)	287,000 L.U.	"	2
VI- 3	Local Cable Network Project (Phase 1)	250,000 L.U.	"	1
VI- 4	Local Cable Network Project (Phase 2)	287,000 L.U.	"	2
VI- 5	Junction Network Project		"	1
<u>Local Telephone Network outside Jakarta</u>				
VI- 6	Sumatera Kotamadya Project I (WITEL I)	117,000 L.U.	5 years	1
VI- 7	Sumatera Kotamadya Project II (WITEL II, III)	91,000 L.U.	"	2
VI- 8	Sumatera Kabupaten Project (WITEL I - III)	71,000 L.U.	"	3
VI- 9	Jawa Kotamadya Project I (WITEL V)	127,000 L.U.	"	1
VI-10	Jawa Kotamadya Project II (WITEL VI)	104,000 L.U.	"	2
VI-11	Jawa Kotamadya Project III (WITEL VII)	201,000 L.U.	"	1
VI-12	Jawa Kabupaten Project (WITEL V - VII)	143,000 L.U.	"	2
VI-13	Bali/Nusa Tenggara/Timor Timur Project (WITEL VIII)	68,000 L.U.	"	3
VI-14	Kalimantan/Sulawesi Kotamadya Project (WITEL IX, X)	117,000 L.U.	"	2
VI-15	Kalimantan/Sulawesi Kabupaten Project (WITEL IX, X)	49,000 L.U.	"	3
VI-16	Maluku/Irian Jaya Project (WITEL XI, XII)	25,000 L.U.	"	3
<u>Toll Switching System</u>				
VI-17	Expansion of Digital Toll Switching System	40,000 CCT	"	1
<u>Terrestrial Transmission</u>				
VI-18	Jakarta-Surabaya Digital M/W System	750 km	4 years	1
VI-19	Jakarta-Pangkalpinang Optical Fiber Submarine Cable System	550 km	3 years	2
VI-20	Pangkalpinang-Sekupang Optical Fiber Submarine Cable System	800 km	4 years	2
VI-21	Palembang-Pangkalpinang Digital M/W System	200 km	3 years	2
VI-22	Pekanbaru-Medan Digital M/W System	500 km	"	1
VI-23	East Indonesia Digital M/W System (Ruteng-Ujung Pandang)	400 km	4 years	3
VI-24	Ambon-Jayapura Optical Fiber Submarine Cable System	1,950 km	5 years	3
VI-25	Subscriber Radio System (Phase 1)	9,000 L.U.	4 years	2
VI-26	Subscriber Radio System (Phase 2)	10,000 L.U.	"	3

Table 14 Main Project in REPELITA-VI (2/2)

Code	Project Title	Project Size	Work Period	Pri- ority
<u>Satellite Transmission System</u>				
VI-27	PALAPA C2 Launching	1 Sat.	5 years	1
VI-28	TDMA Satellite Link Expansion	up to 11,340 ch	"	2
VI-29	33 Small Earth Stations (SBK)	33 SBK	"	3
VI-30	Replacement of SBB and SBS	19SBB/20SBS	"	3
<u>Others</u>				
VI-31	Expansion of Packet Data Communication System	up to 4,400 terminals	3 years	1
VI-32	Expansion of Radio Paging System	up to 80,000 L.U.	"	2
VI-33	Expansion of Land-Mobile Telephone System	up to 15,500 L.U.	"	3
VI-34	ISDN Expansion Project		3 years	2
VI-35	Provision of Coin Telephone Sets	33,000 sets	"	1
VI-36	Network Management Center Project (Switching)	12 centers	4 years	1

11. Economic Evaluation

(1) Consumer Surplus Analysis

The consumer surplus to be produced from telephone service subscription is highest in Jakarta: it is estimated to be approximately 3.6 times the installation fee and approximately 2.6 times the national average in 1994. (Refer to Figure 19.) The Plan 2 produces twice larger amount of consumer surplus than the Plan 1.

The amount of consumer surplus will tend to increase as development advances through REPELITA-V, REPELITA-VI and REPELITA-VII.

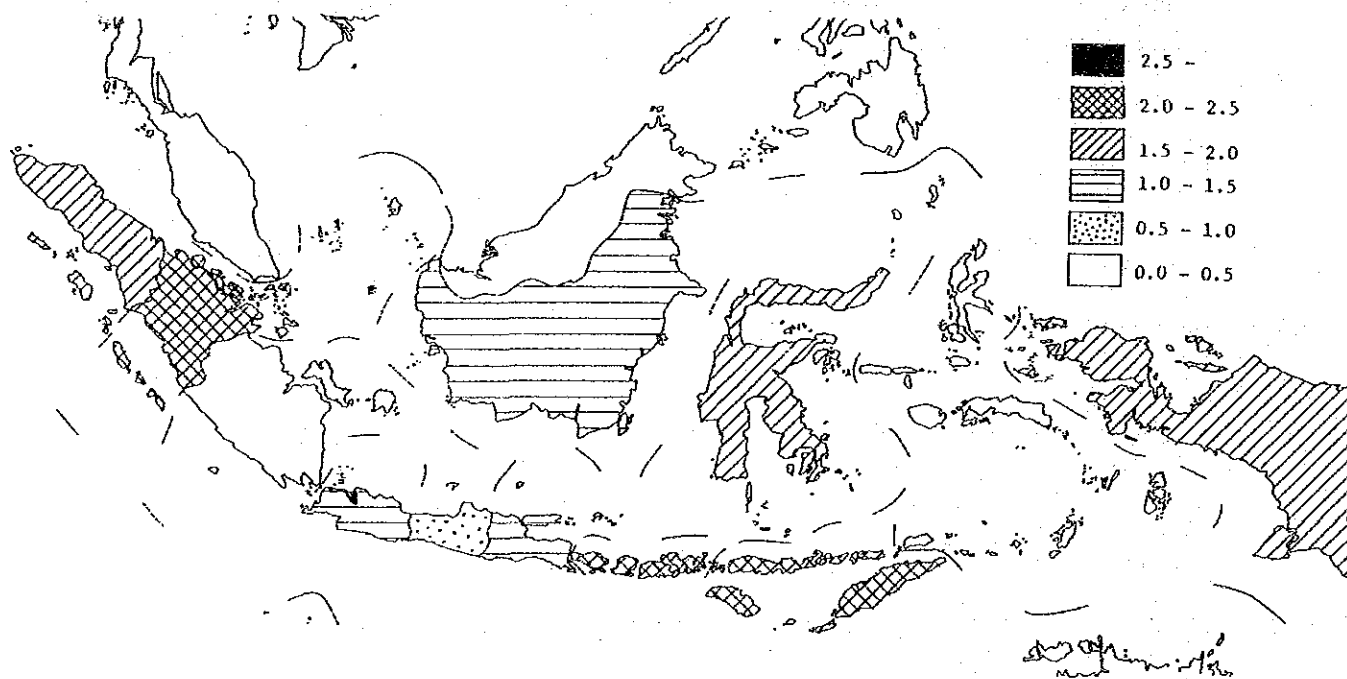

Figure 19 Consumer Surplus from Telephone Subscription



## (2) Input-Output Table Analysis

The input-output relationship between the communications sector and other sectors was analyzed by using the Input-Output Table (1980) and analysis results are summarized as follows:

1) Outputs of the communication sector are mainly demanded by the following sectors for their production.

- Water Transport
- Air Transport
- Other Industry
- Construction
- Financing/Real Estate
- Public Administration Service

2) The communications sector demands mainly outputs of the following sectors for its own production.

- Service Allied to Transport
- Communication (own output)
- Financing/Real Estate
- Trade/Restaurant
- Air Transport
- Public Administration Service

## 12. Proposals

The following recommendations are proposed as the basic guidelines for the Long-Term Telecommunications System Development Plan up to the Year 2004:

- 1) The telephone service capacity expansion plan shall be made according to how GDP grows. The target figures in 2004 are 4,500 L.U. if the GDP growth rate is 3% per year and 6,200 L.U. if the GDP growth rate is 5% per year (See Table 6).
- 2) The non-telephone services capacity expansion plan shall be made according to how the demands grow. The plan shall be carried out according to the schedule shown in Table 7.
- 3) Integration of the Telecommunications networks shall be promoted toward establishment of ISDN by 2004. Then, new services shall be offered by ISDN (See Figure 12).
- 4) The actual development plan shall be carried out according to the most suitable development scenario chosen out of the four previously discussed development scenarios by examining the national economic conditions and the management conditions of PERUMTEL.
- 5) The backbone terrestrial transmission routes shall be developed according to the long-term development plan shown in Figure 17.
- 6) The satellite earth stations shall be constructed according to the long-term development plan shown in Figure 18.
- 7) The telephone service capacity expansion project shall be a packaged project which integrates switching system, local cable network and junction network projects. Table 11 through Table 14 show lists of main projects which shall be carried out during REPELITA-V and REPELITA-VI.

### 13. Advice

Many projects must be carried out in the future in order to achieve what is discussed and recommended in the Long-Term Telecommunications System Development Plan.

The on-going PELITA-IV is not following the schedule very well. One of the reasons for the delay seems to arise from some institutional problems which may work as obstacles for telecommunications projects in Indonesia. The following advice points out how these problems shall be solved to achieve more smooth executions of the future projects:

- 1) The budgetary limit for a small project be raised to allow PERUMTEL to implement such project at his own discretion in well balanced timing considering total network development.
- 2) In order to promote import of materials necessary for production of telecommunications equipment in Indonesia, foreign exchange rationing be increased for telecommunications equipment manufacturers, such as PT. INTI, etc.

Also for PERUMTEL, foreign exchange rationing be increased at least for several years to come because a number of telecommunications projects must be implemented with foreign loans.

- 3) Some taxation policies to improve the financial condition of PERUMTEL be taken for promoting investment projects.
- 4) On the facility expansion planning, the attention be paid keeping well balanced networks among different technical fields.



**CHAPTER 1**  
**INTRODUCTION**



## CHAPTER 1 INTRODUCTION

### 1-1 Structure of the Study Report

This report consists of The Long Term Development Plan (VOLUME-I), and A Proposal for REPELITA-V (VOLUME-II).

#### VOLUME-I: The Long Term Development Plan

The Long Term Development Plan covers the years from 1989 to 2004 which correspond to the period of three five-year plans, REPELITA-V, REPELITA-VI and REPELITA-VII. The plan presents development objectives, review of current state, targets and strategies, facility expansion plans, financial/economic evaluations and an Impact Analysis by the Input-Output Table.

As for the plans of REPELITA-VI and VII, several cases of possible development plans, which are considered to be realistic in the future under certain circumstances, are proposed and examined by the Development Strategies Simulation Model.

#### VOLUME-II: A Proposal for REPELITA-V

In the proposed plan of REPELITA-V, which is to be followed by REPELITA-IV presently underway, detailed development proposals for constructing one million new line units are discussed. Main items of the proposals cover subscriber demand forecasts at regional level, development targets, traffic forecasts, circuit calculation, facility expansion plans and a list of projects together with project digests.

## 1-2 Purpose and Process of the Study

### 1-2-1 Background of the Study

The government of Indonesia has been making a considerable amount of efforts to develop the telecommunications services through the expansion programs of PELITA-III (1979-1984) and PELITA-IV (1984-1989). The rapid technical progress and emergence of new services in telecommunications have produced a need for a thorough reexamination of both demand and supply problems of the telecommunications services and, hence, a need for establishing revised future development plans. The government of Indonesia has requested the government of Japan to assist in establishing a long term telecommunications development plan which is best suited for exploiting the benefits of new technologies and services and in formulating primary projects of coming REPELITA-V and IV.

The government of Japan has responded to the request by forming a preliminary study team. The preliminary study team proposed a scope of work, which was accepted by the both governments in November, 1985.

The main study was carried out by the following steps:

- |   |                       |
|---|-----------------------|
| 1) Study preparation in Japan           | Jan. - Feb. 1986      |
| 2) Survey and its analysis in Indonesia | Feb. - Mar. 1986      |
| 3) Work in Japan (1)                    | May - Jun. 1986       |
| 4) Work in Indonesia                    | Jun. - Sep. 1986      |
| 5) Work in Japan (2)                    | Sep. 1986 - Feb. 1987 |

### 1-2-2 Purpose and Execution Process of the Study

The purpose of the study is to establish a long term plan for the development of the telecommunications networks and services up to the year 2004 (the end of REPELITA VII) for future establishment of



Integrated Services Digital Network (ISDN) and provision of new telecommunication services.

The guidelines for the study are set as follows;

- 1) To establish development objectives up to the year 2004 and to examine development strategies.
- 2) To formulate long-term development programs in estimating the scale of networks and facilities required.
- 3) To evaluate programs in the financial/economic aspects and to examine the projects feasibilities.

The work schedule of the study is shown in Figure 1-2-1.

The study was carried out by the following five stages;

- First stage : The field surveys including the sample area surveys for the purpose of fact-findings
- Second stage: The analyses of the collected data and development of a strategy simulation model
- Third stage : Formation of development scenarios and the analyses of the scenarios by the simulation model
- Fourth stage: Formation of the optimum development scenario and project formation.
- Fifth stage : A telecommunications development impact analysis by the Input-Output Table on the national development

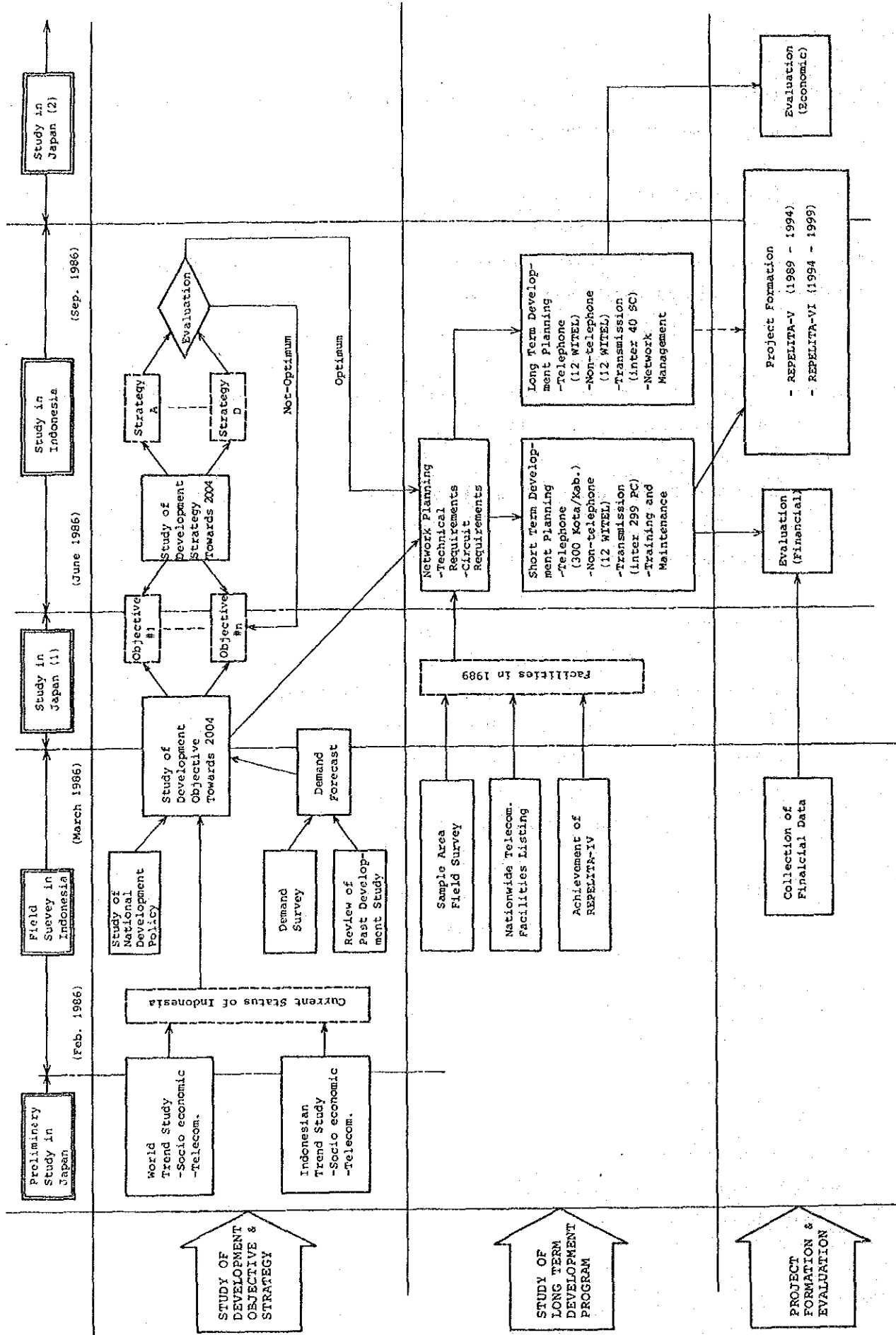

Figure 1-2-1 Study Flow for Long Term Telecommunication Development Planning