

GOVERNMENT OF THE KINGDOM OF THAILAND
MINISTRY OF INTERIOR
EXPRESSWAY AND RAPID TRANSIT AUTHORITY OF THAILAND

Feasibility Study
on
The Second Stage Expressway System
in
The Greater Bangkok

FINAL REPORT
VOLUME III : DRAWINGS

NOVEMBER, 1983

JAPAN INTERNATIONAL COOPERATION AGENCY

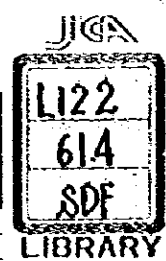

JICA LIBRARY



1000646023

**GOVERNMENT OF THE KINGDOM OF THAILAND
MINISTRY OF INTERIOR
EXPRESSWAY AND RAPID TRANSIT AUTHORITY OF THAILAND**

***Feasibility Study
on
The Second Stage Expressway System
in
The Greater Bangkok***

**FINAL REPORT
VOLUME III : DRAWINGS**

NOVEMBER, 1983

JAPAN INTERNATIONAL COOPERATION AGENCY

国際協力事業団	
受入 月日 '84. 3. 29	122
登録No. 10158	614
	SDF

DRAWING SCHEDULE

INDEX OF SHEETS	SCALE	TOTAL NUMBER OF SHEET
MAP OF PROJECT AREA AND LOCATION	1 : 100,000	1
TYPICAL CROSS SECTIONS	1 : 200	2
PLANS AND PROFILES	H = 1 : 5,000 V = 1 : 500	12
INTERCHANGE	1 : 3,000 1 : 500	2
TYPICAL ARRANGEMENT OF ON OFF RAMPS	1 : 2,000 1 : 200	1
AT-GRADE INTERSECTIONS	1 : 1,000 1 : 200	4
TOLL PLAZA	1 : 1,000 1 : 200	1
STANDARD VIADUCT ARRANGEMENT	1 : 300 1 : 200	2
TYPICAL STRUCTURES	1 : 300 1 : 200	2
	TOTAL	27

LEGEND :

PLAN

- Center Line of Project Road
- Boundary Line of Right of Way
- Station (Every Five Hundred Meters)

PROFILE

- Proposed Gradient Line
- Existing Ground Height
- Ground Level Section
- Toll Gate
- R Radius
- A Parameter of Clothoid Curve

MAP OF PROJECT AREA

THE SECOND STAGE EXPRESSWAY SYSTEM IN GBA		
SCALE 1:100,000	MAP OF PROJECT AREA AND LOCATION	Dwg. No 1

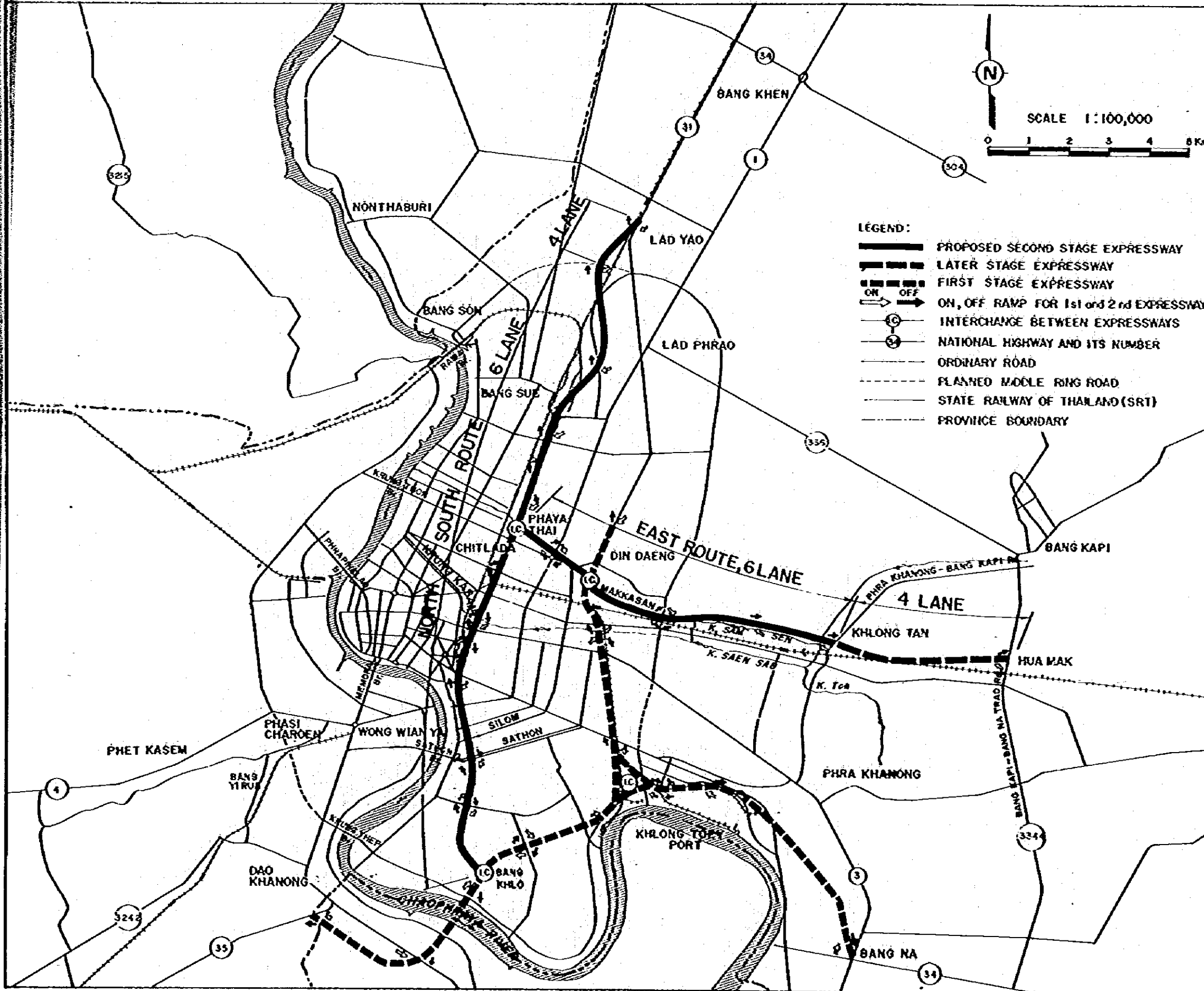

LOCATION MAP (THAILAND)

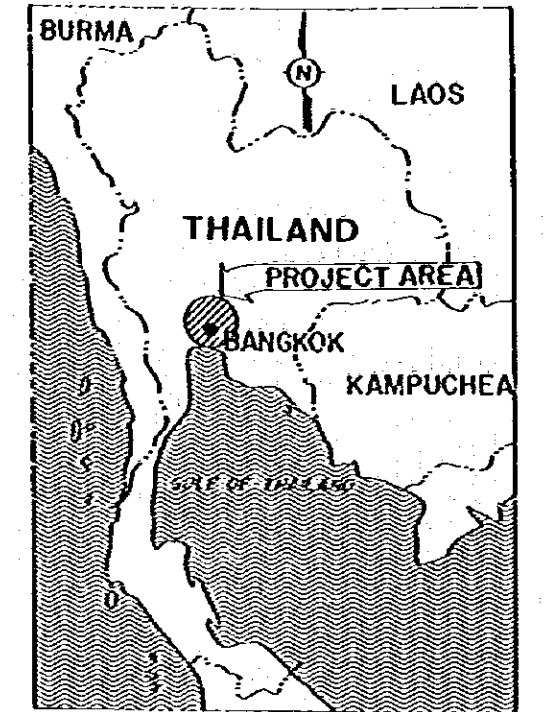

LOCATION MAP (BANGKOK)

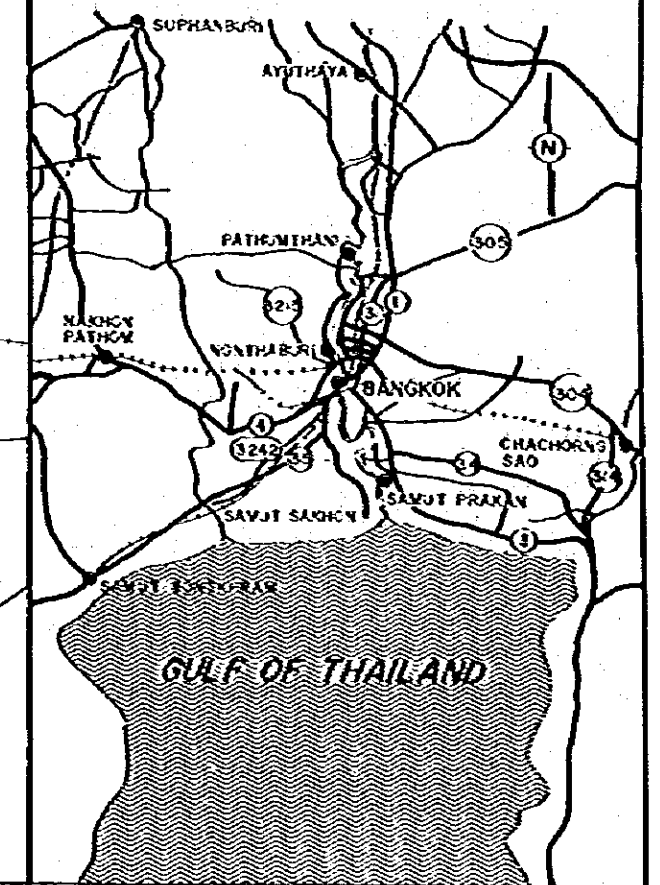

TYPICAL CROSS SECTIONS OF THE EXPRESSWAY

6 - LANE ROAD OF ELEVATED SECTION

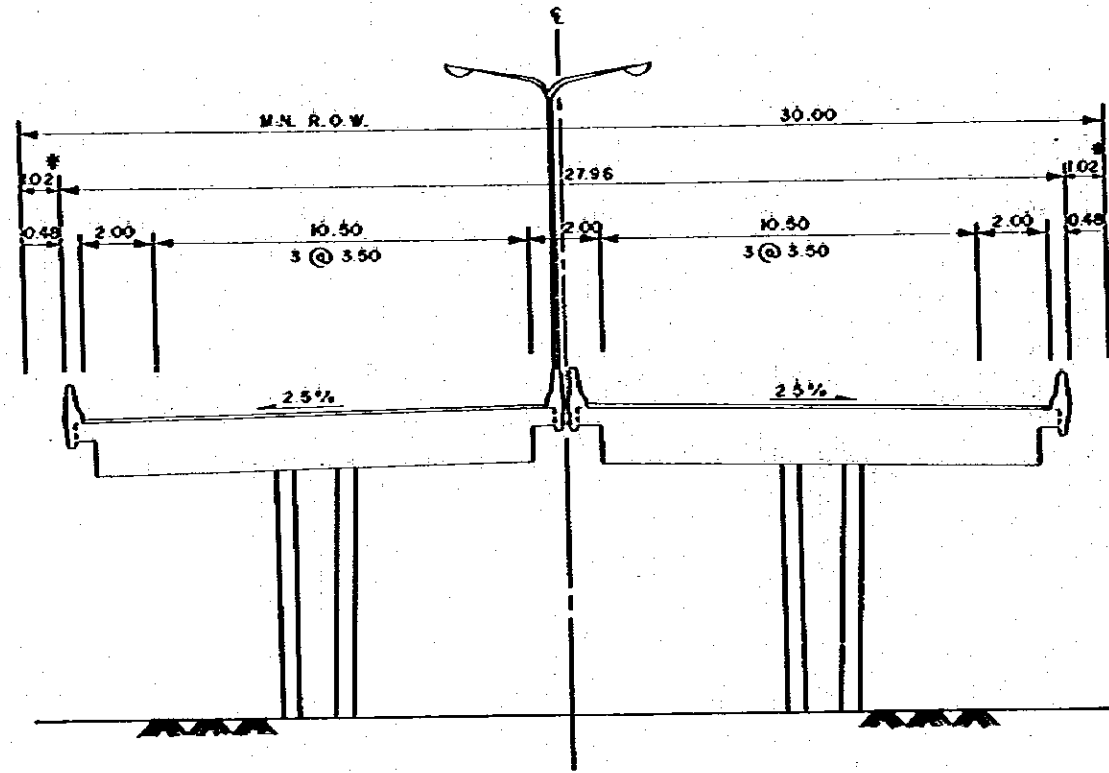

6 - LANE ROAD OF UNDERCROSSING SECTION

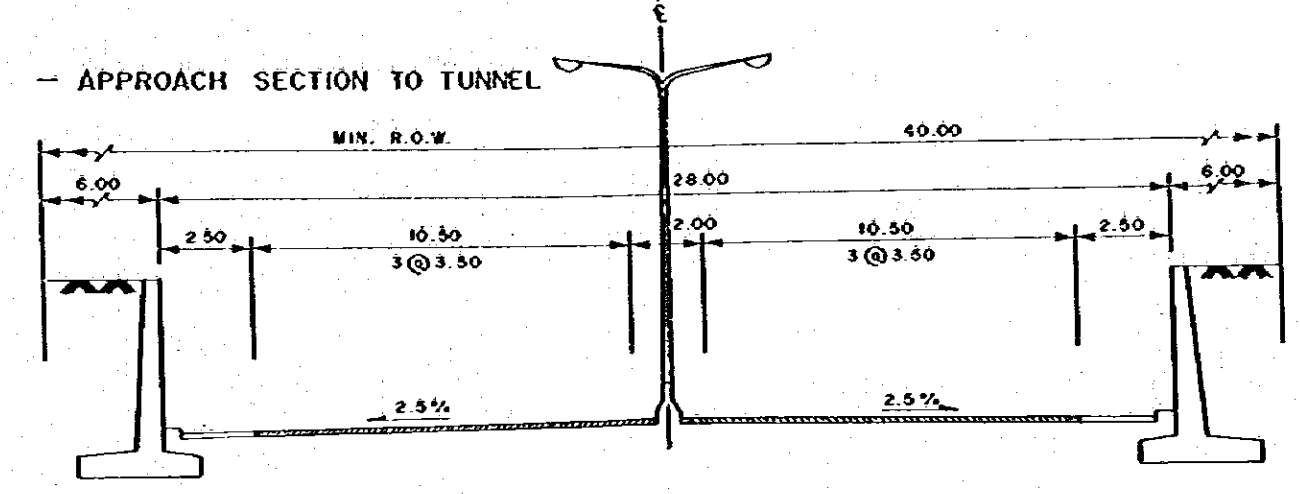

TUNNEL SECTION

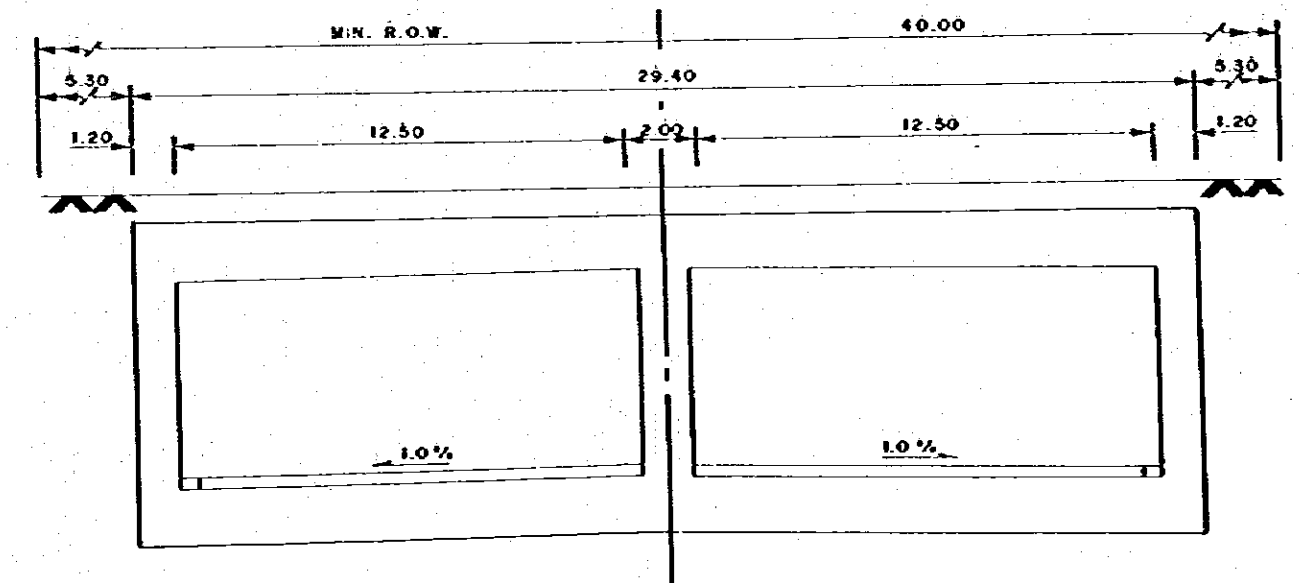

4 - LANE ROAD OF ELEVATED SECTION

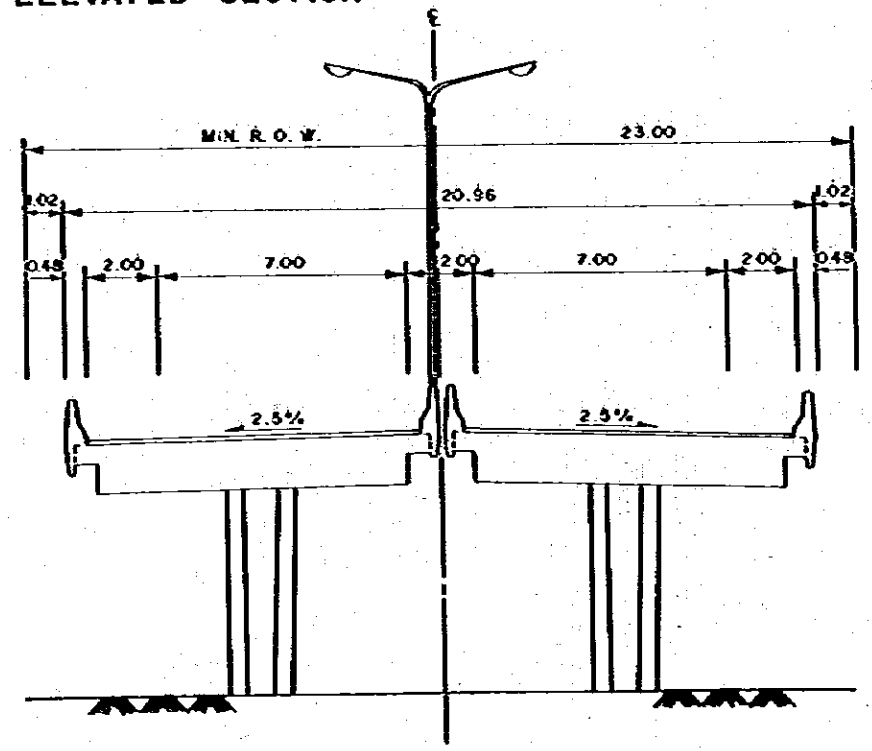

NOTE :

THE FIGURES WITH ASTERISK SHOW ABSOLUTE MINIMUM VALUES. THEY SHALL BE SUBSTITUTED BY 6 METERS OF DESIRABLE MINIMUM VALUES TO PROVIDE SET BACK DISTANCE WHERE THE VIADUCTS ARE PLANNED WITHIN THE ROW OF THE EXISTING OR PLANNED STREETS.

TYPICAL CROSS SECTIONS OF INTERCHANGES
AND ON - OFF RAMP

1 - LANE ONE WAY

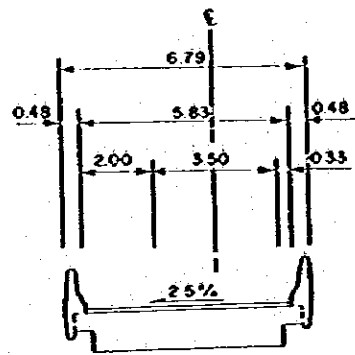

2 - LANE ONE WAY

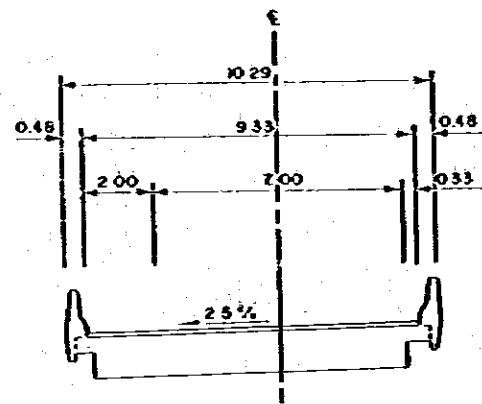

2 - LANE TWO WAY

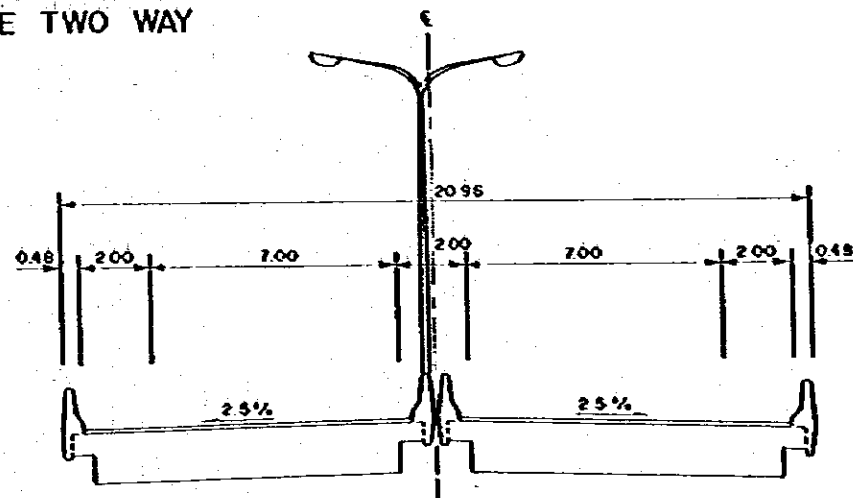

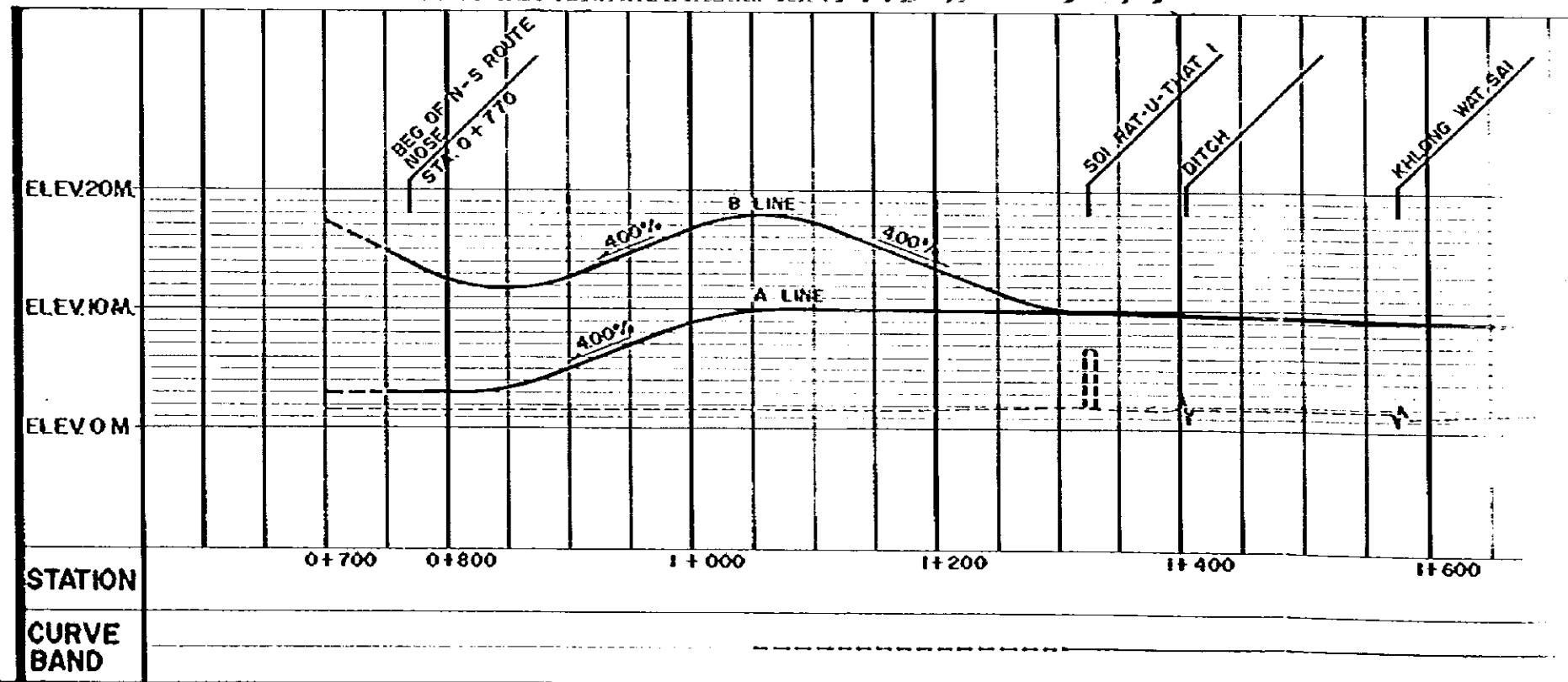
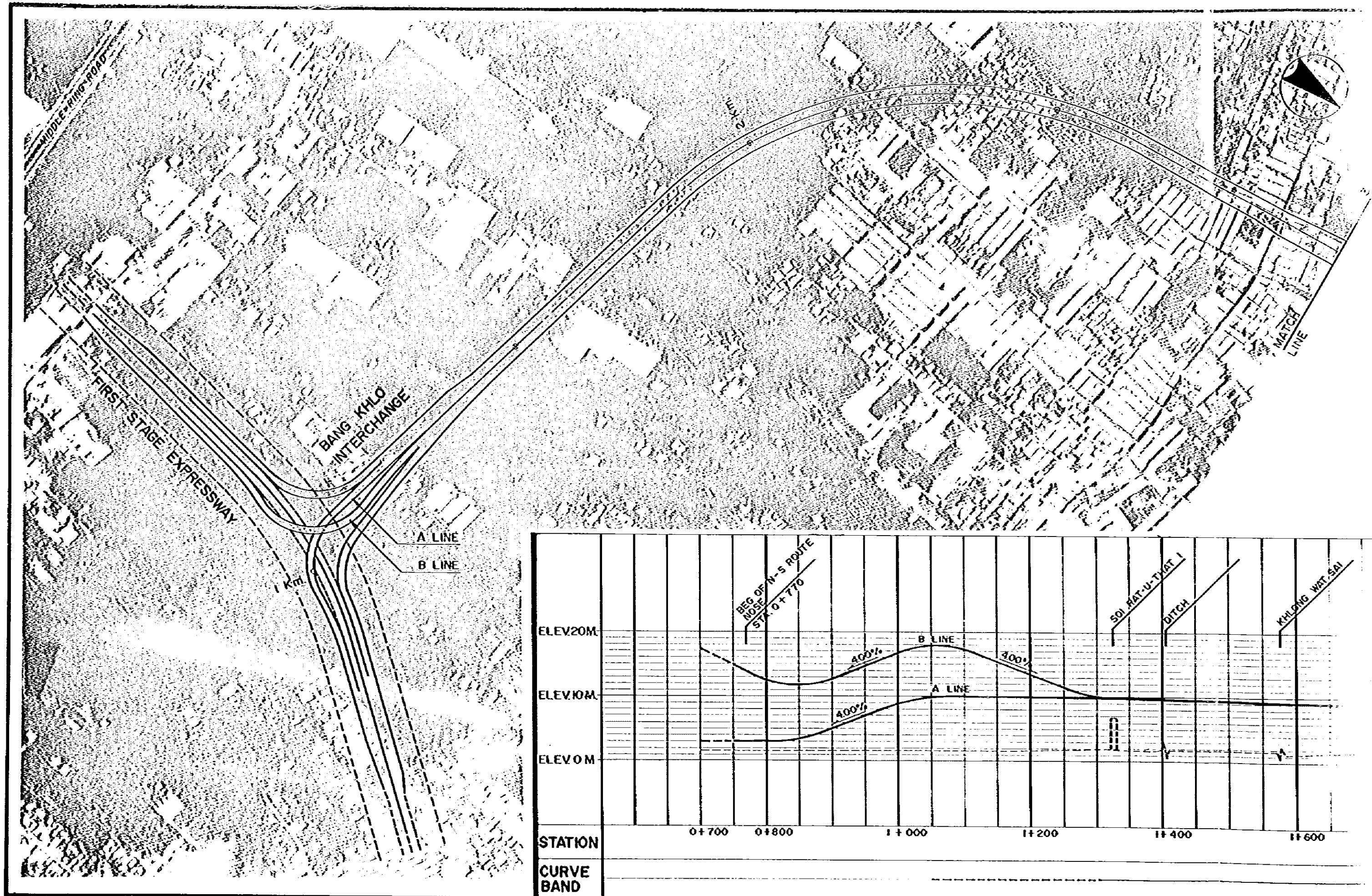

THE SECOND STAGE EXPRESSWAY SYSTEM
IN THE GREATER BANGKOK

SCALE
1 : 500
1 : 5000

N-S ROUTE, PLAN AND PROFILE
(STA. 0 + 770 - STA. 3 + 000)

Dwg. No.
4

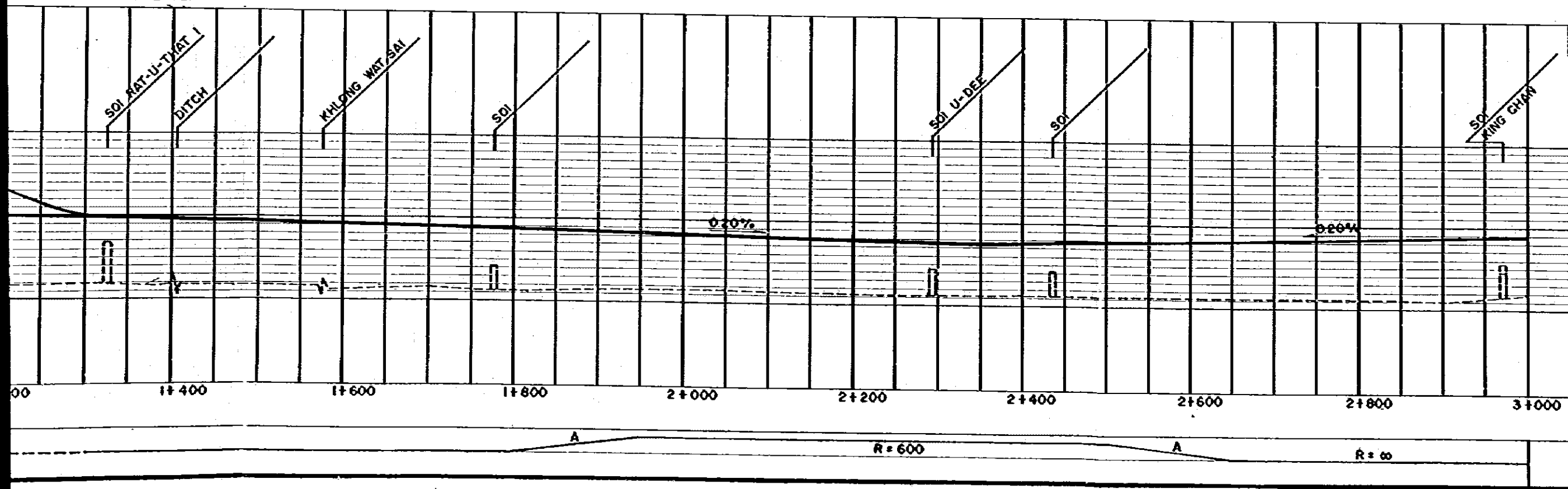
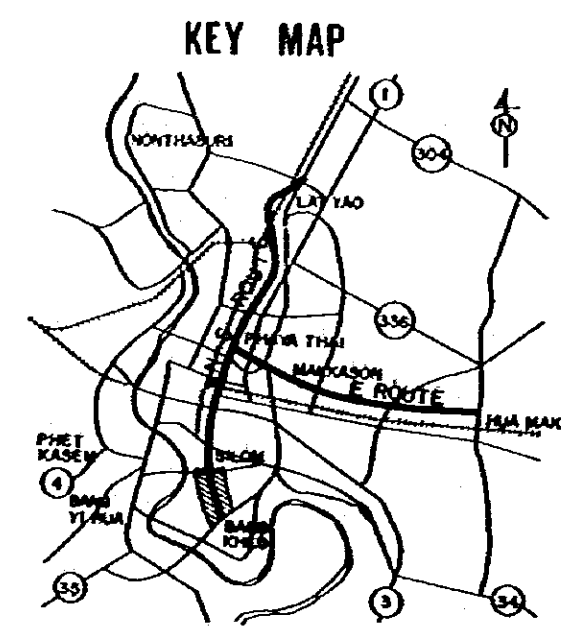

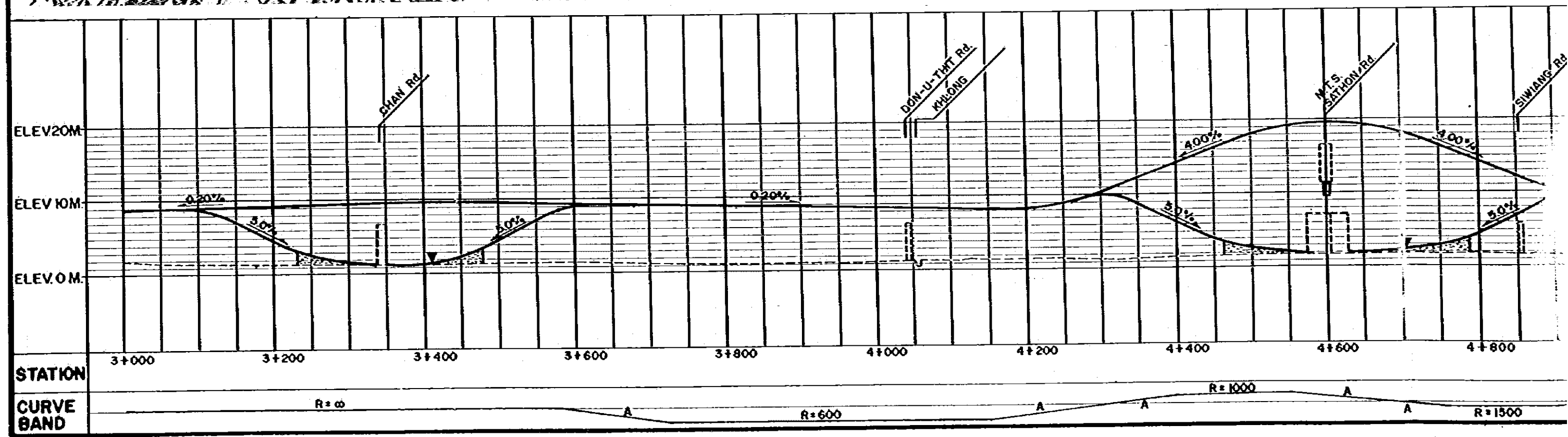
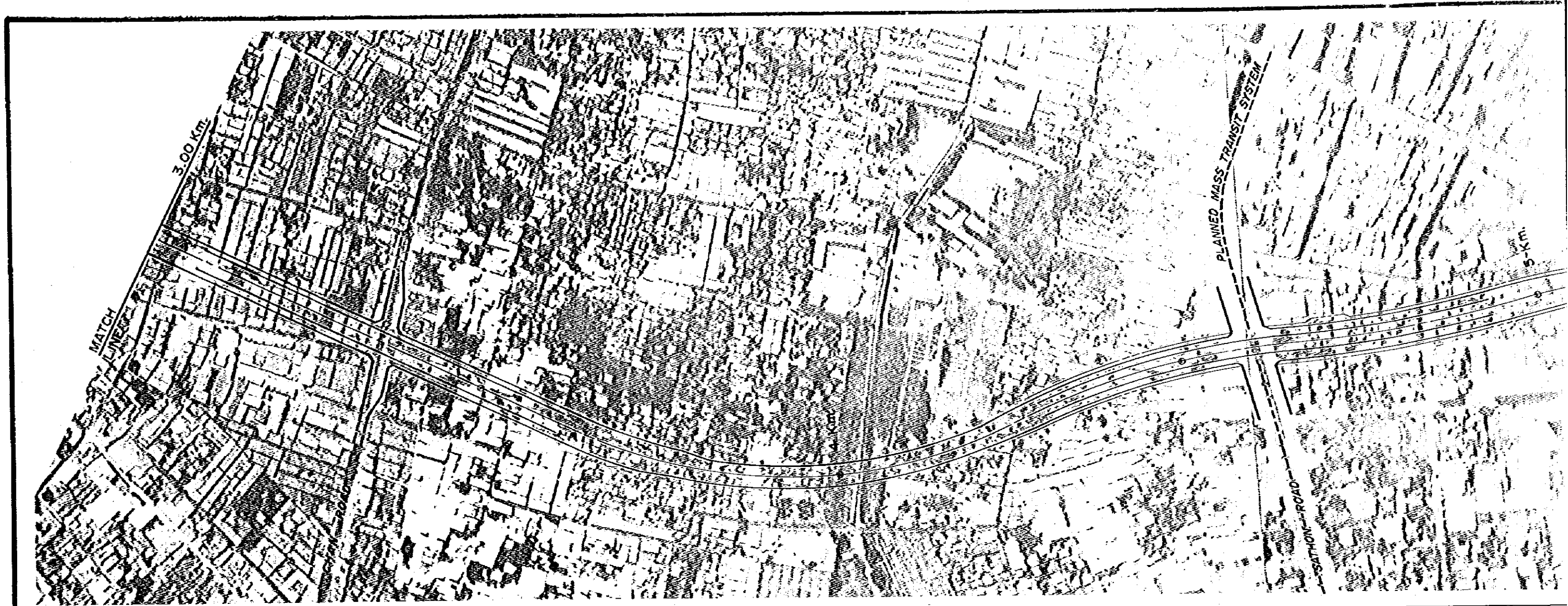

THE SECOND STAGE EXPRESSWAY SYSTEM
IN THE GREATER BANGKOK

SCALE
1: 600
1: 6000

N - S ROUTE, PLAN AND PROFILE
(STA. 3+000 - STA. 6+000)

Dwg. No.
5

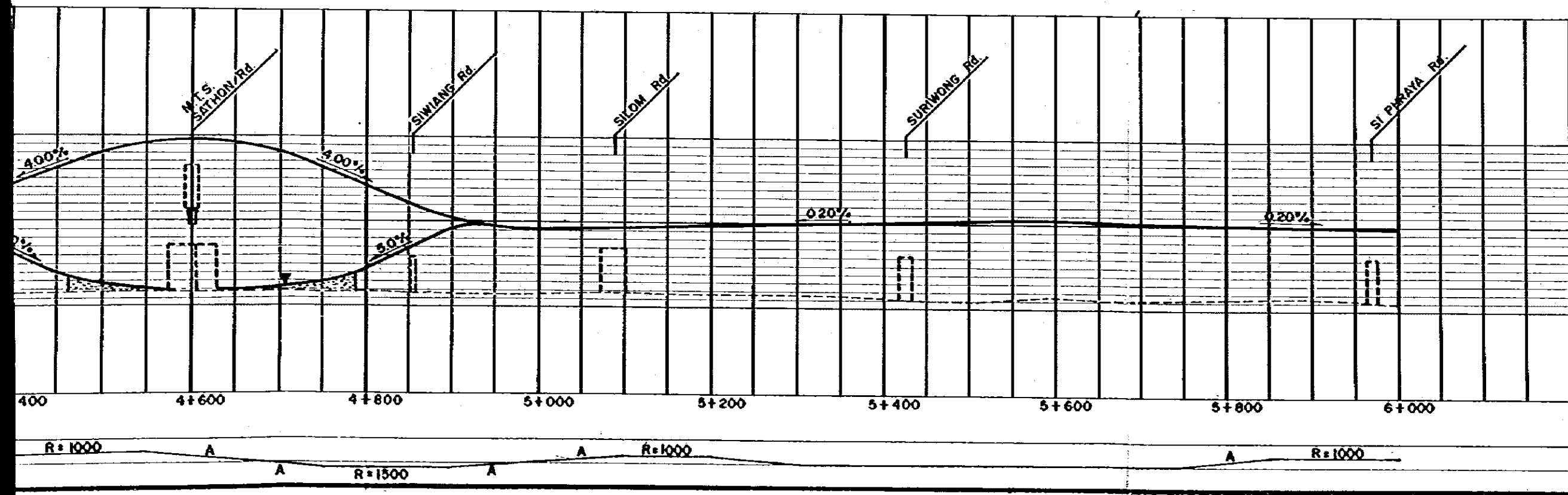
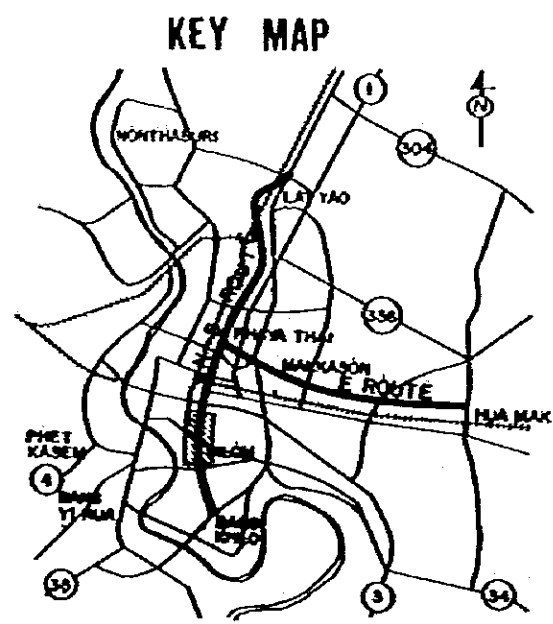

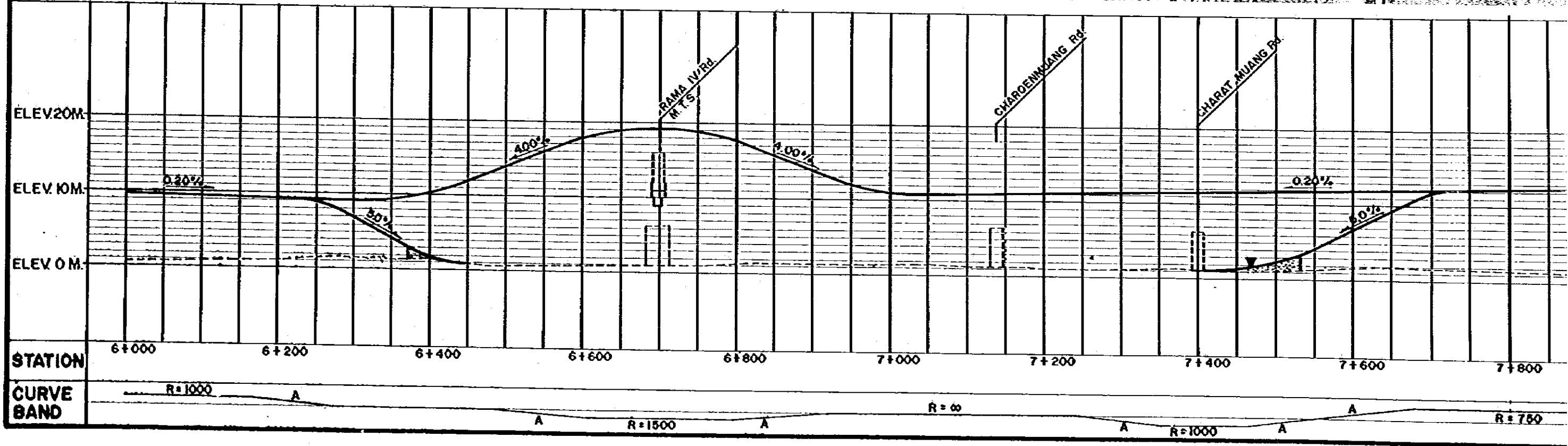
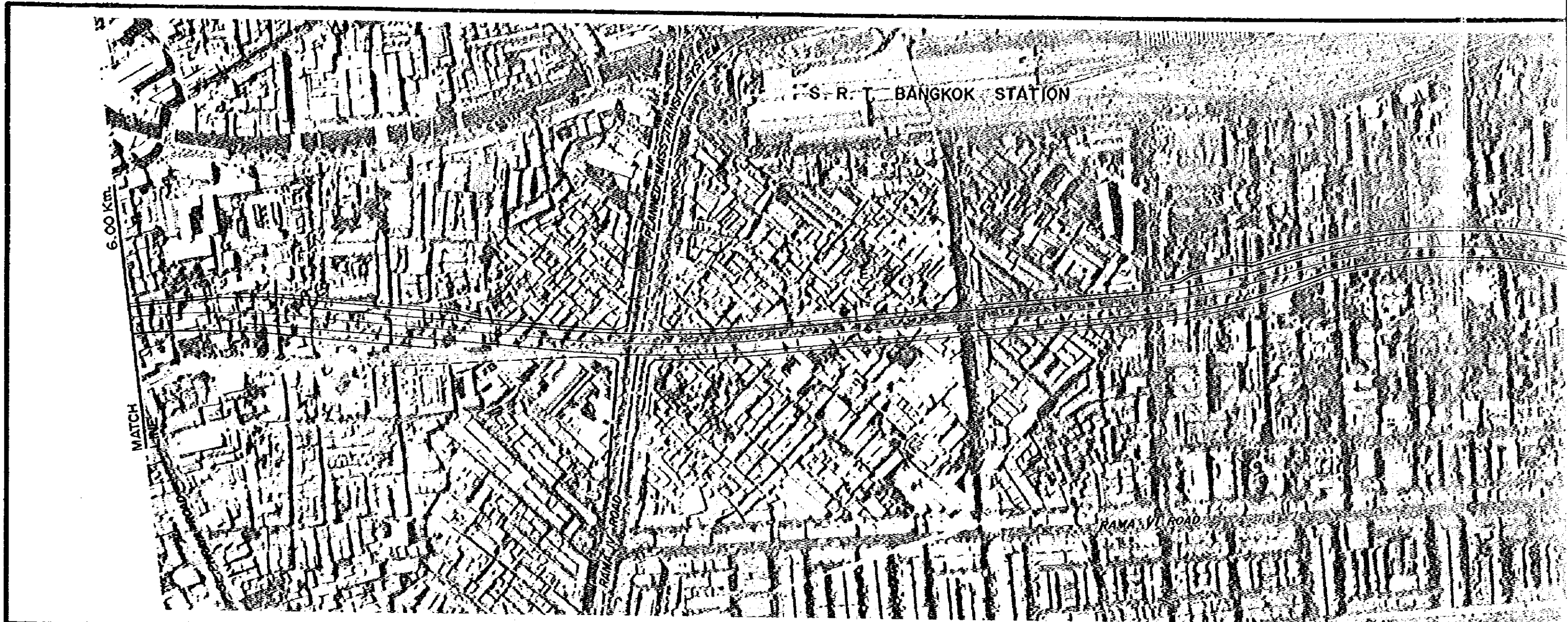

THE SECOND STAGE EXPRESSWAY SYSTEM
IN THE GREATER BANGKOK

SCALE
1:500
1:5000

N-S ROUTE, PLAN AND PROFILE
(STA. 6+000 - STA. 9+000)

Dwg. No.
6

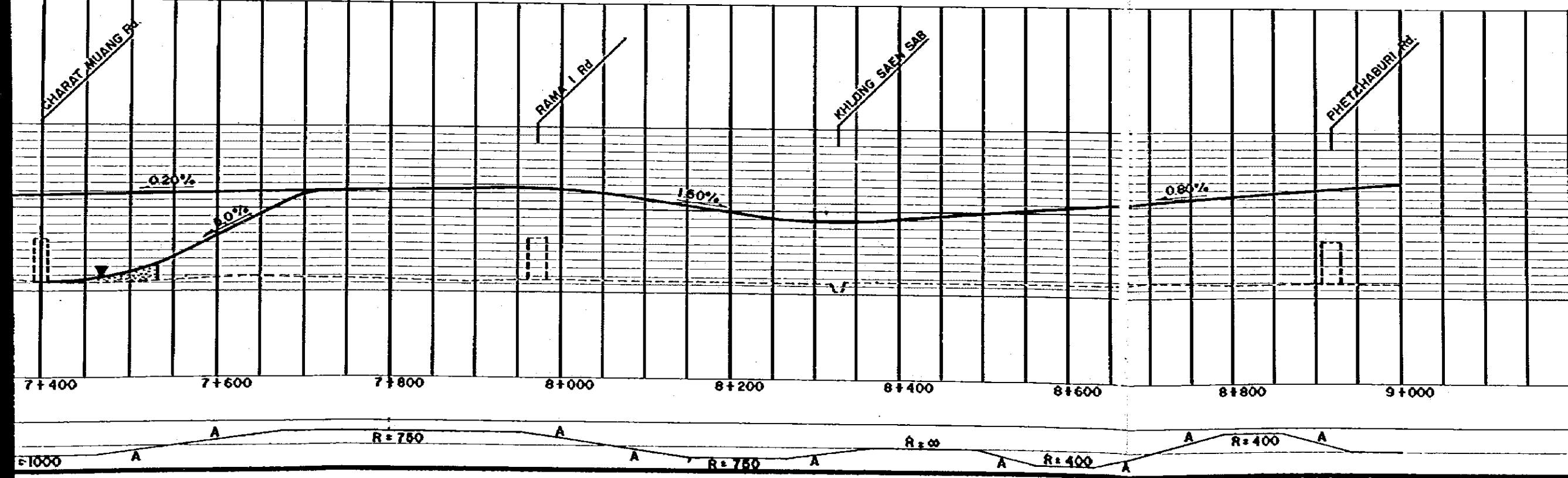
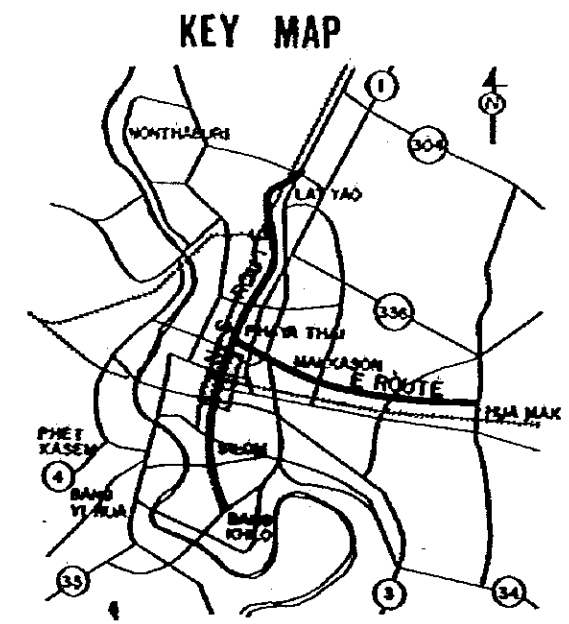
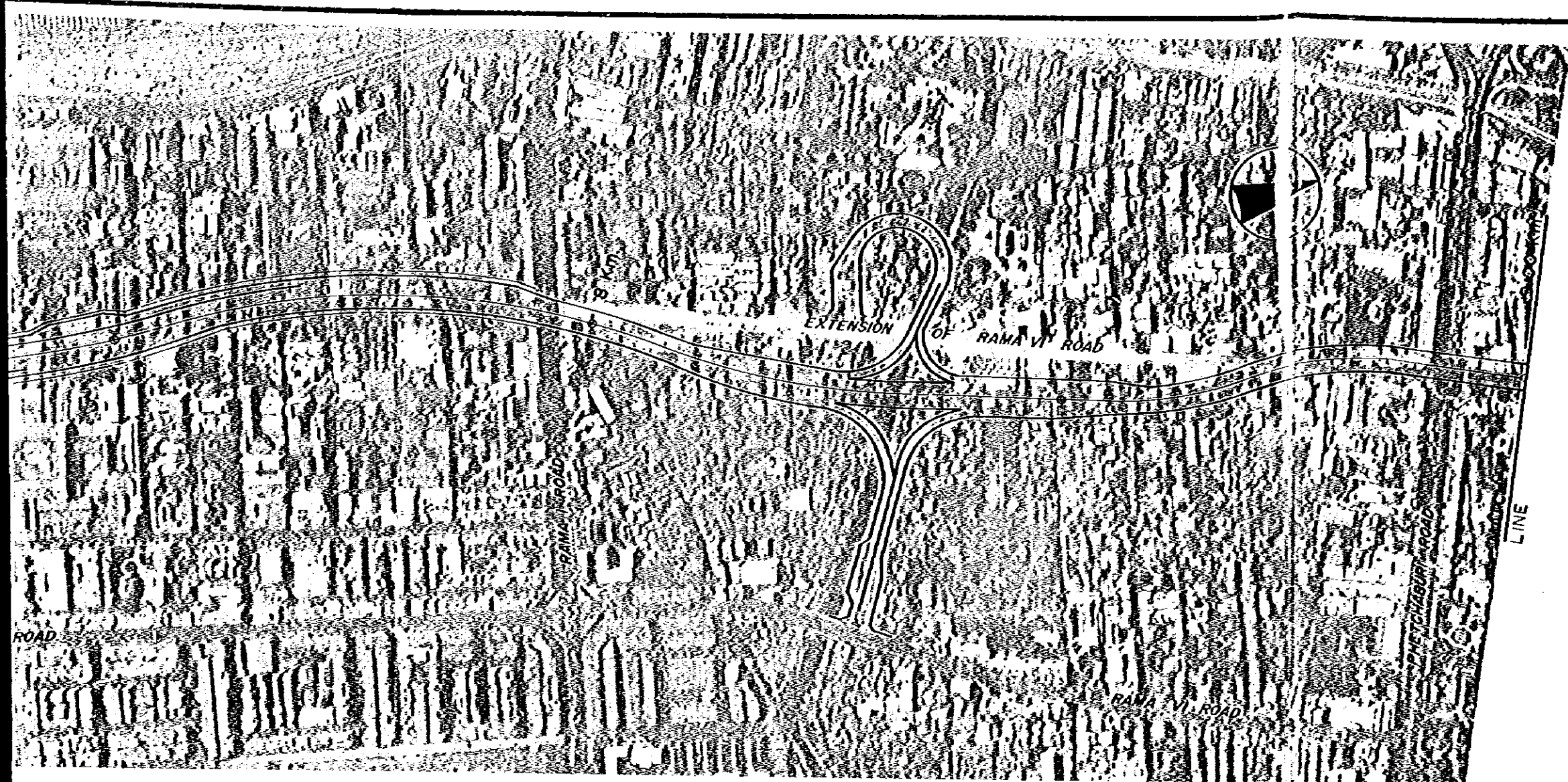

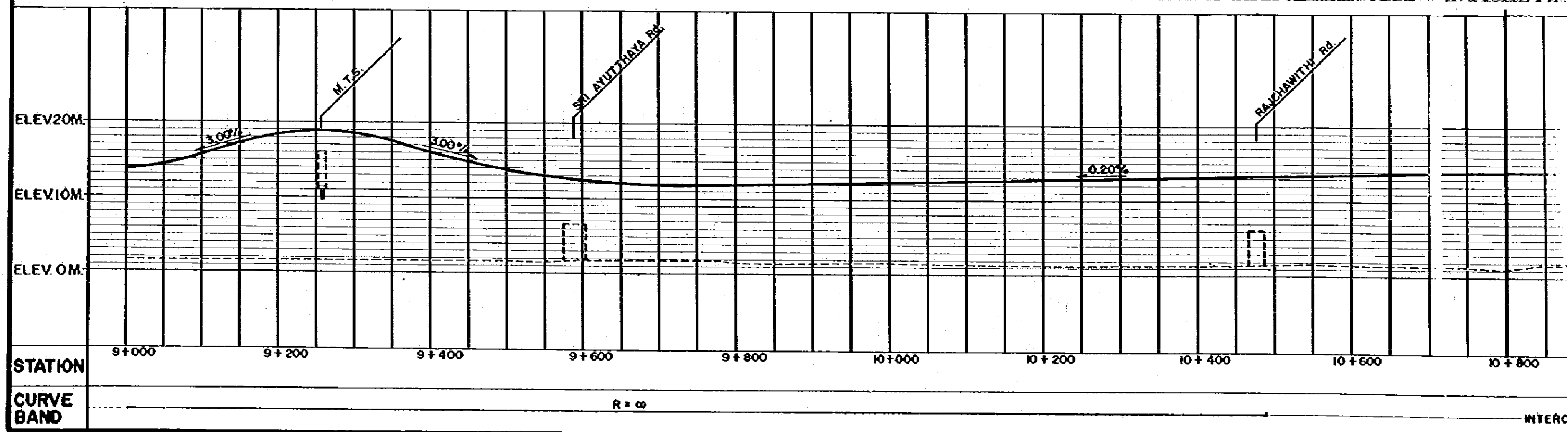
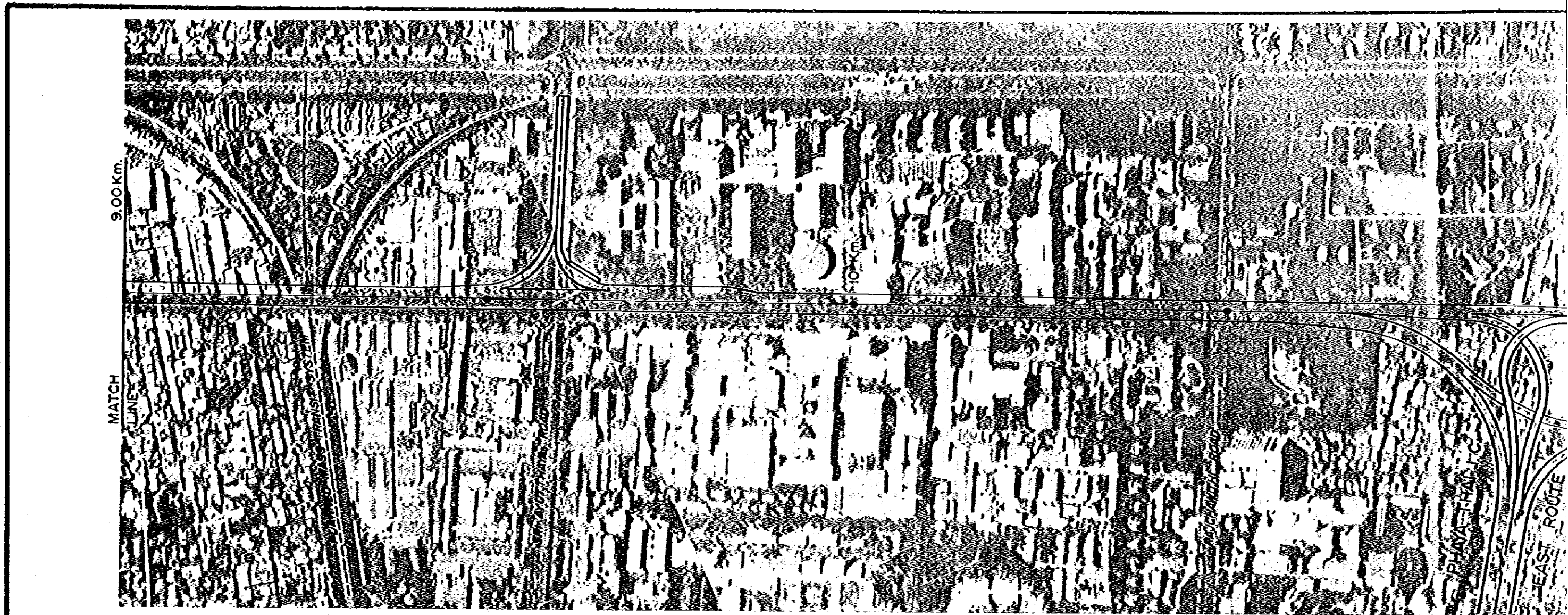

THE SECOND STAGE EXPRESSWAY SYSTEM
IN THE GREATER BANGKOK

SCALE 1 : 500 1 : 5000	N - S ROUTE, PLAN AND PROFILE (STA. 9+000 - STA. 12+000)	Dwg. No. 7
------------------------------	---	---------------

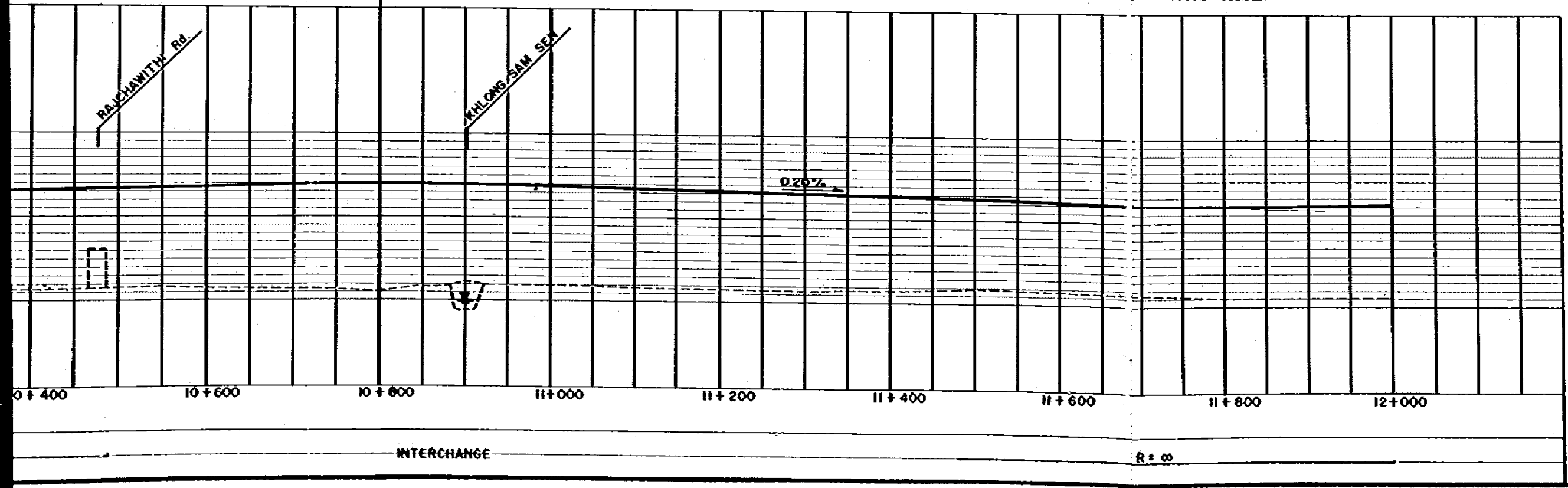
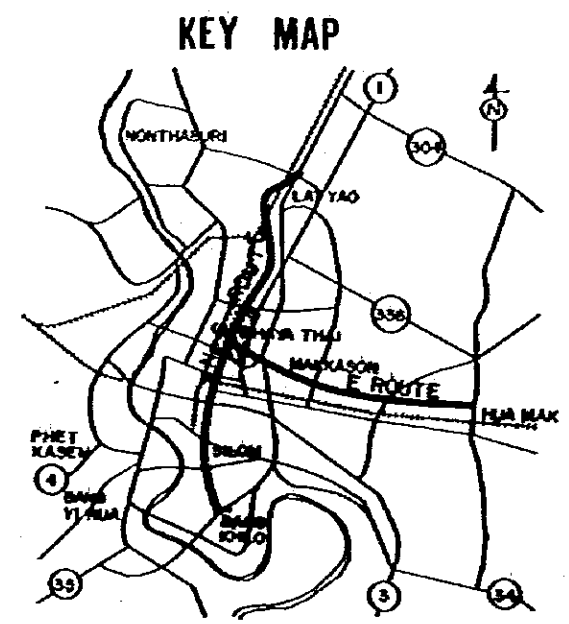
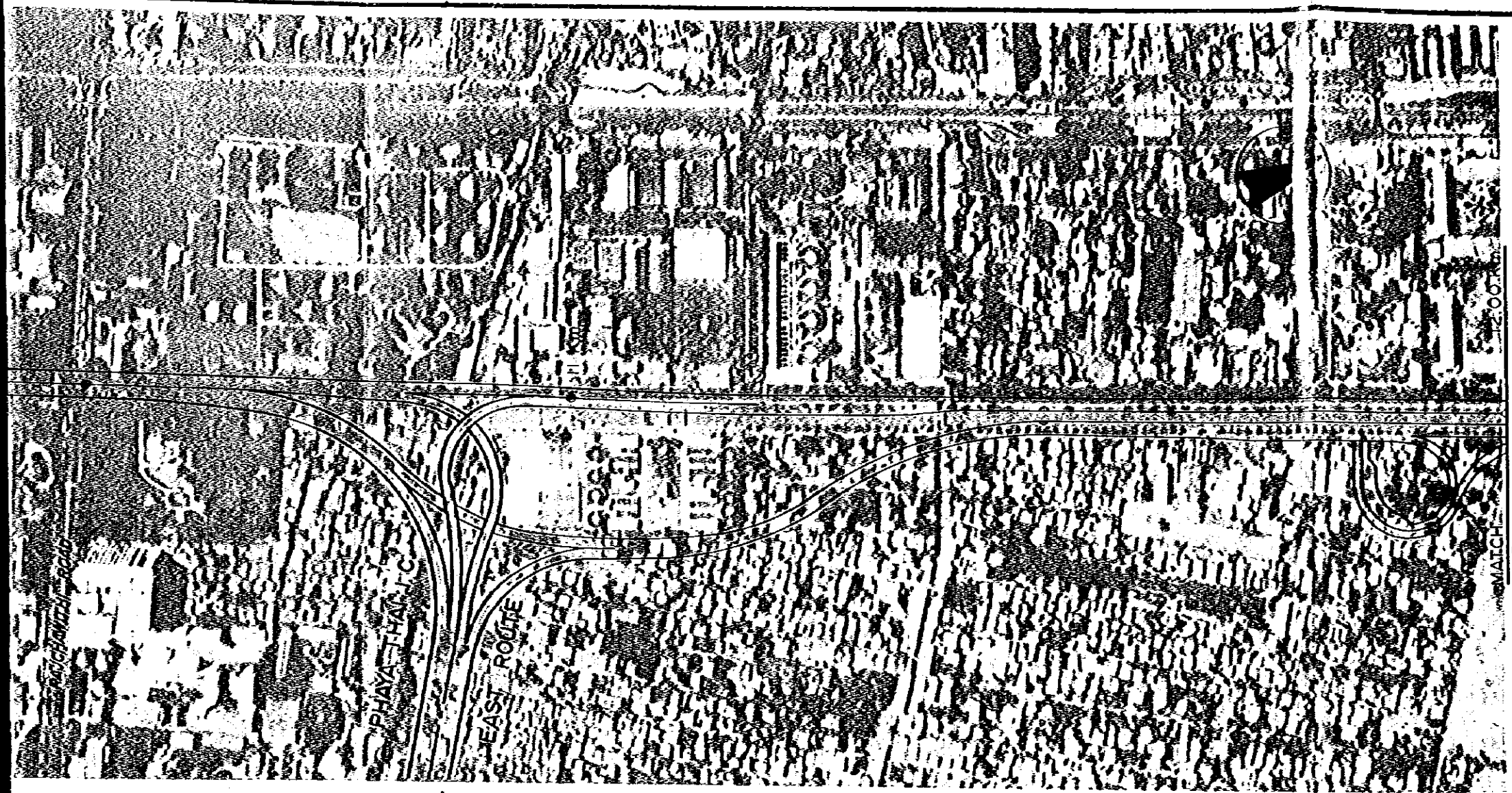

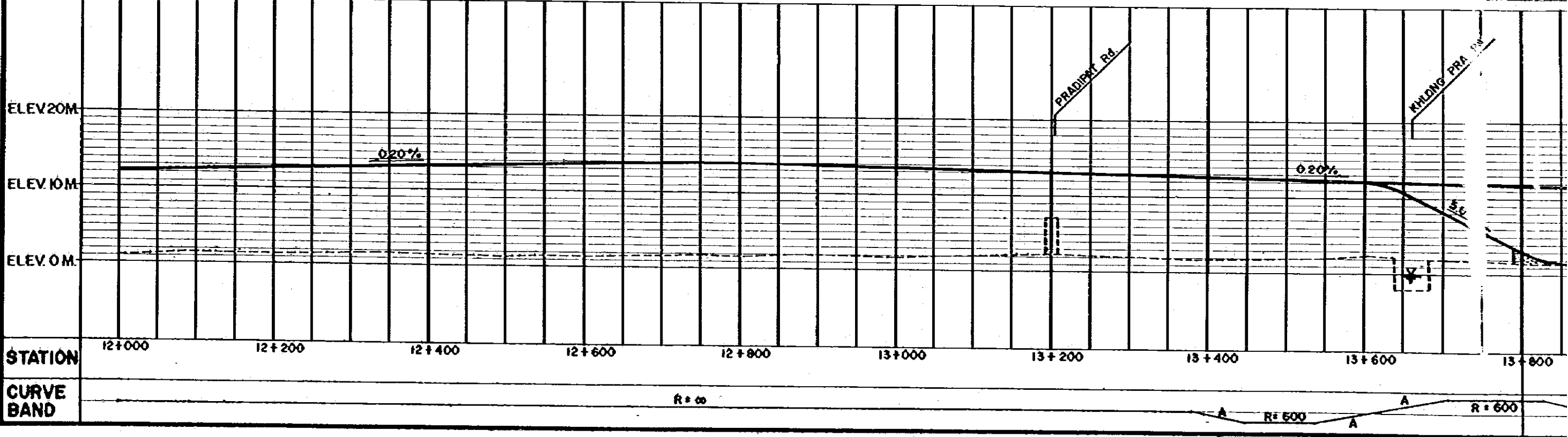
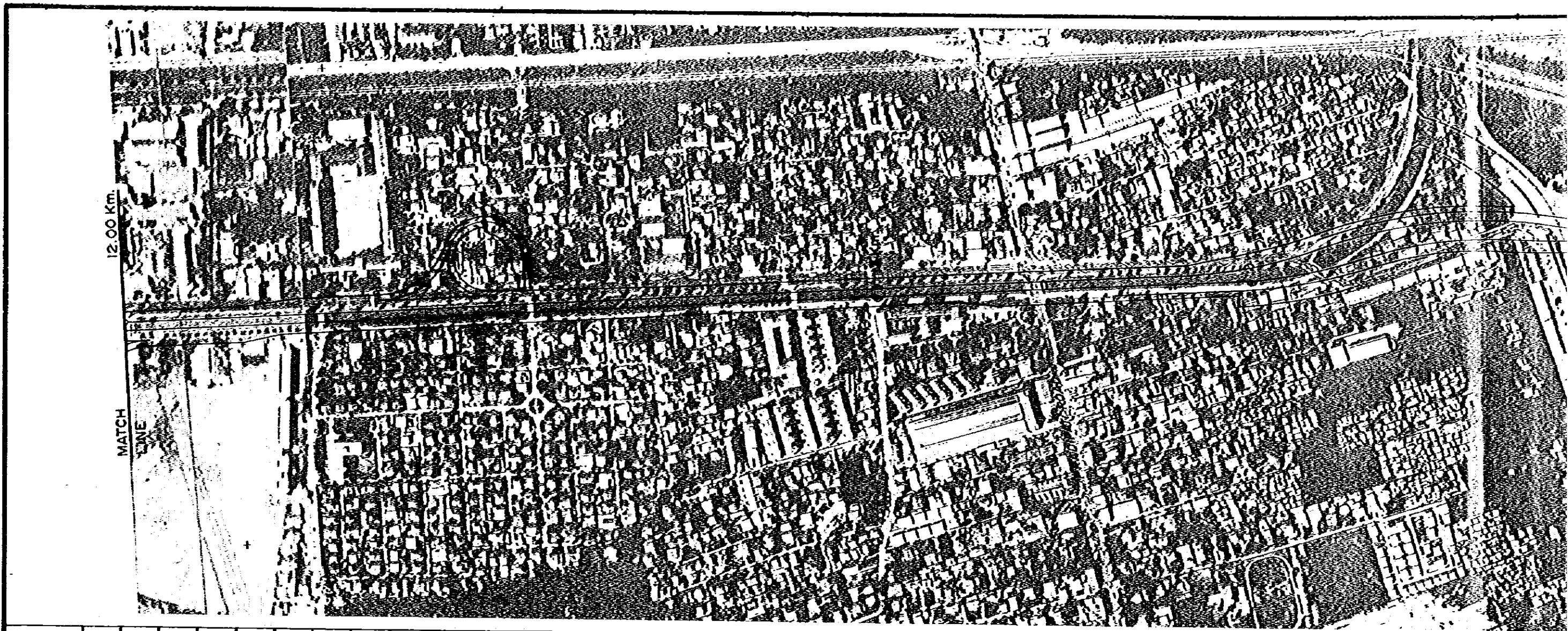

THE SECOND STAGE EXPRESSWAY SYSTEM
IN THE GREATER BANGKOK

SCALE
1:500
1:5000

N - S ROUTE, PLAN AND PROFILE
(STA. 12+000 - STA. 15+000)

Dwg. No.
8

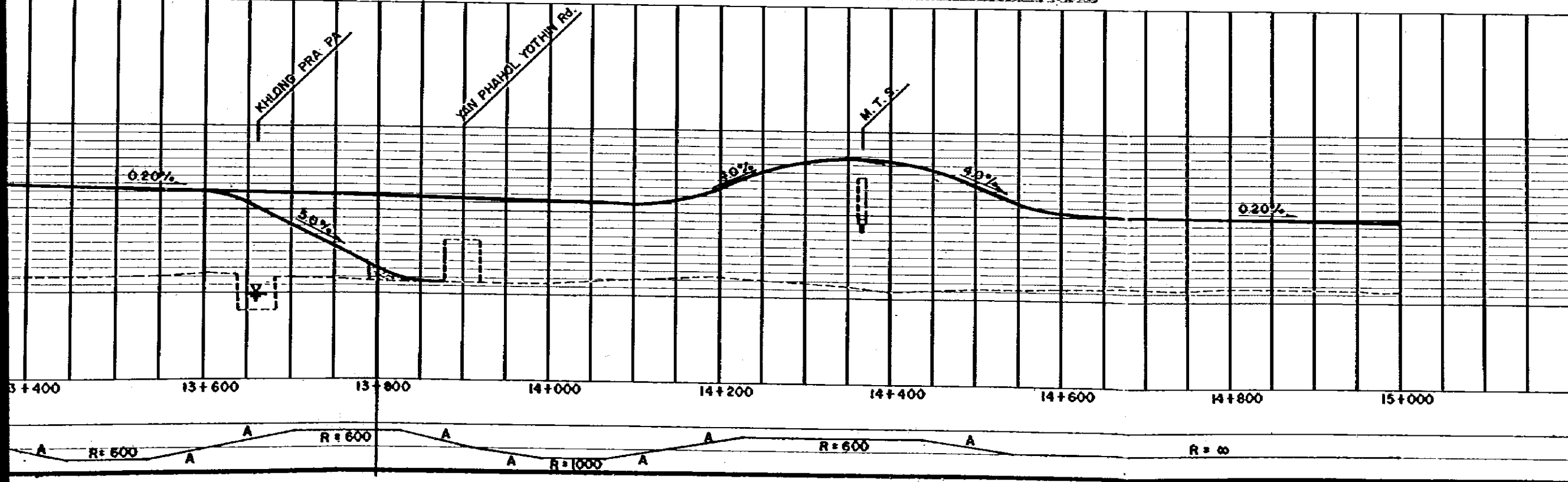
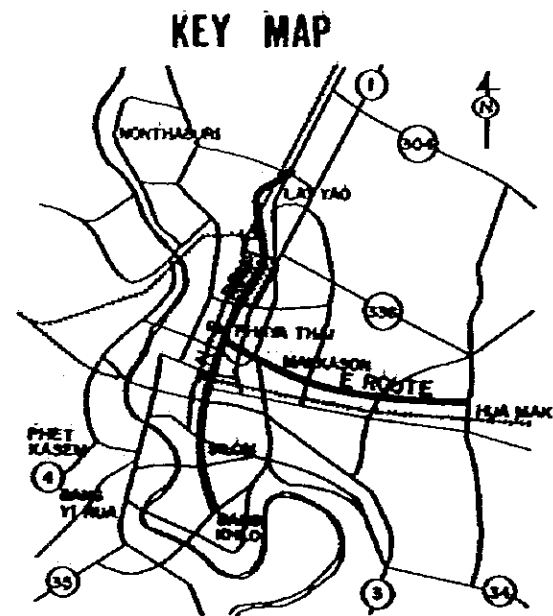
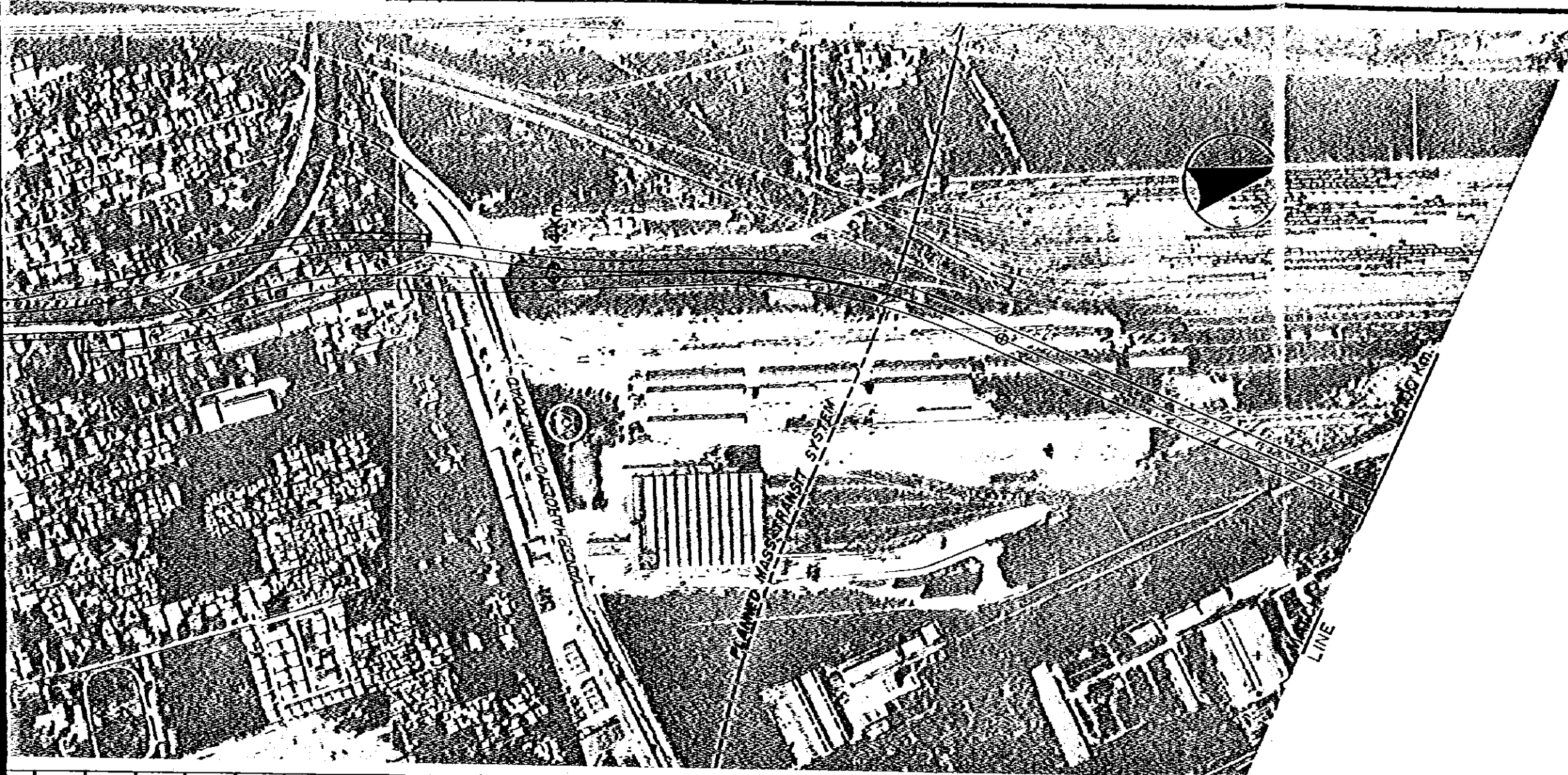

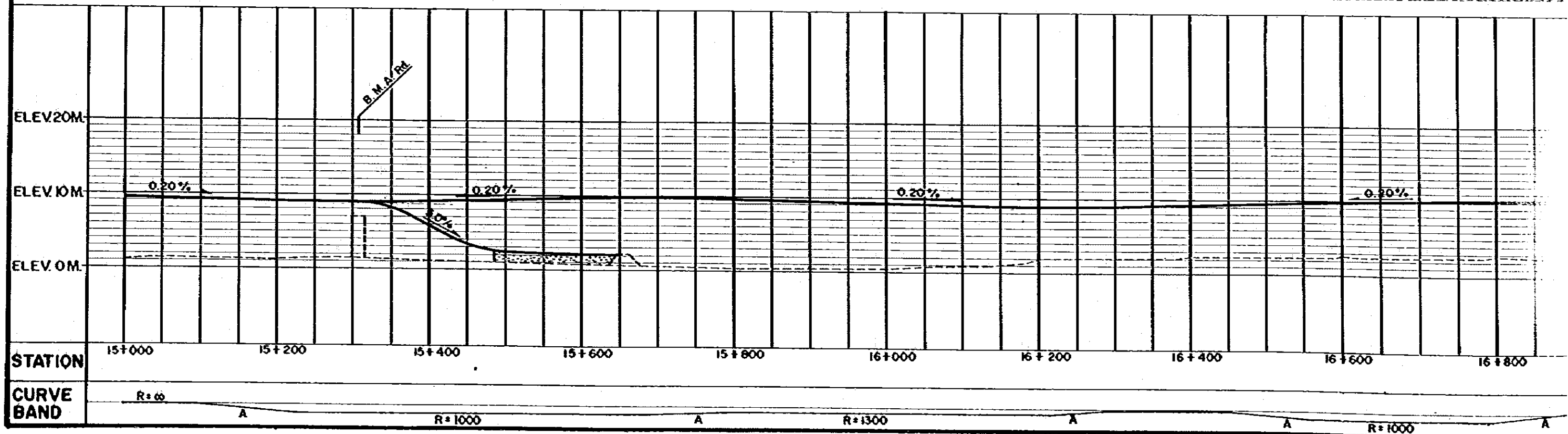
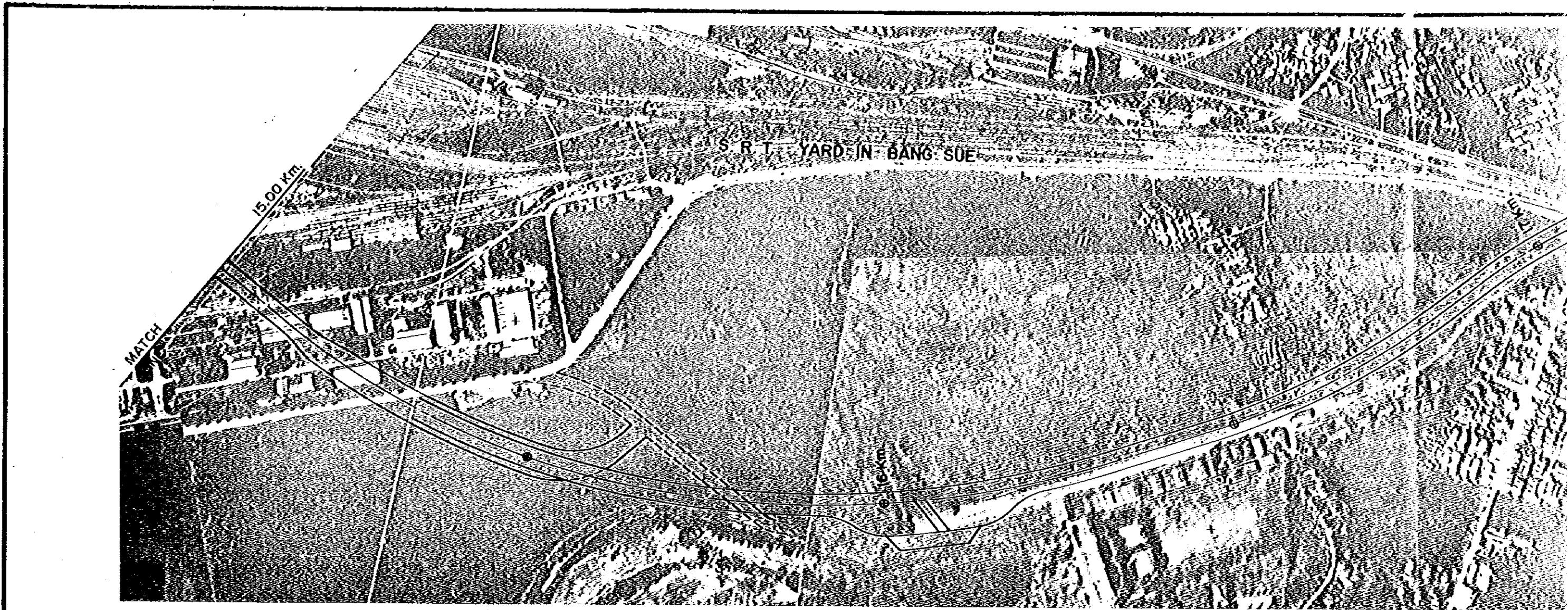

THE SECOND STAGE EXPRESSWAY SYSTEM
IN THE GREATER BANGKOK

SCALE
1: 500
1: 5000

N-S ROUTE, PLAN AND PROFILE
(STA. 15+000 - STA. 18+000)

Dwg. No.
9

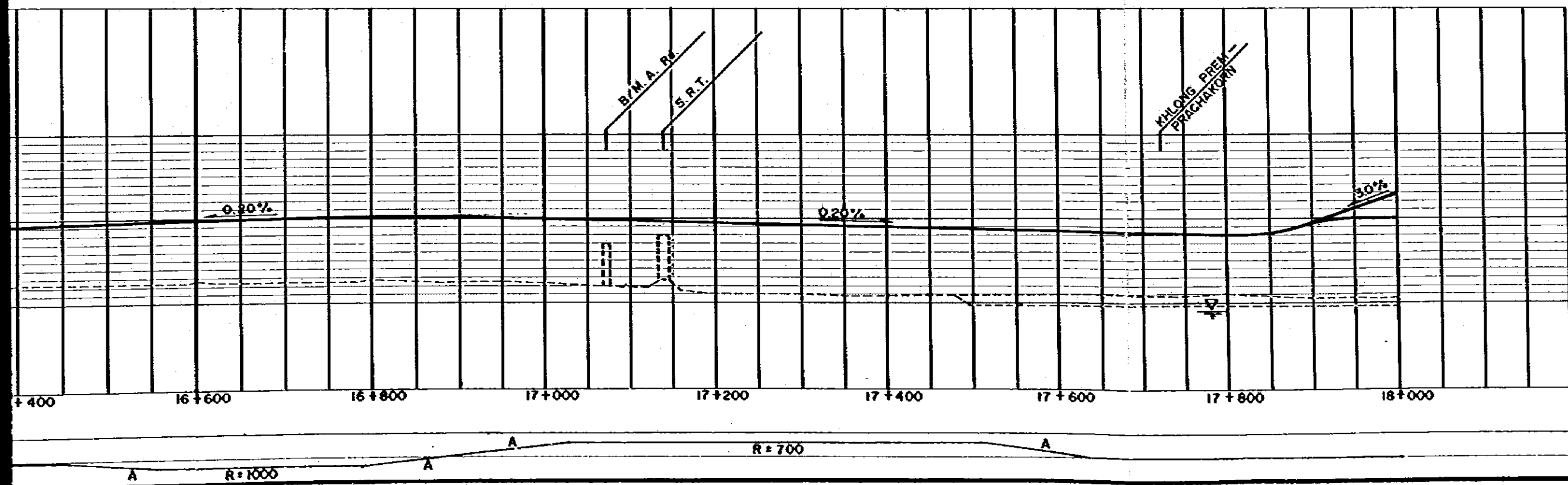
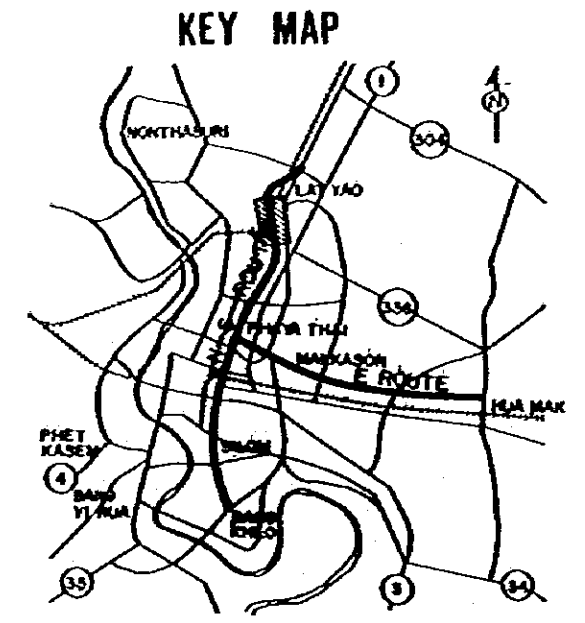

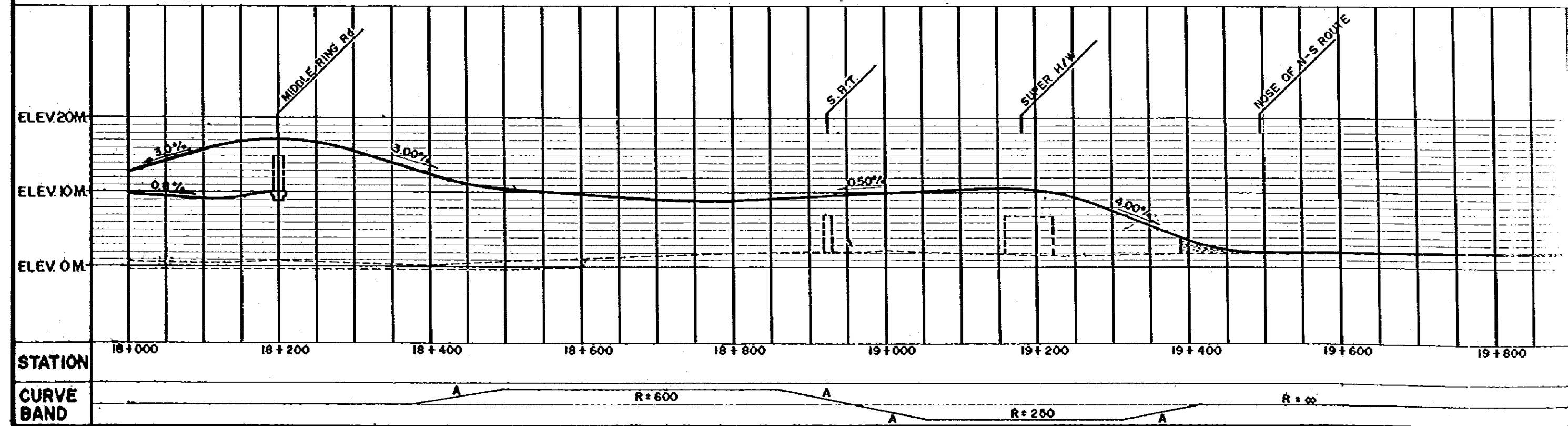
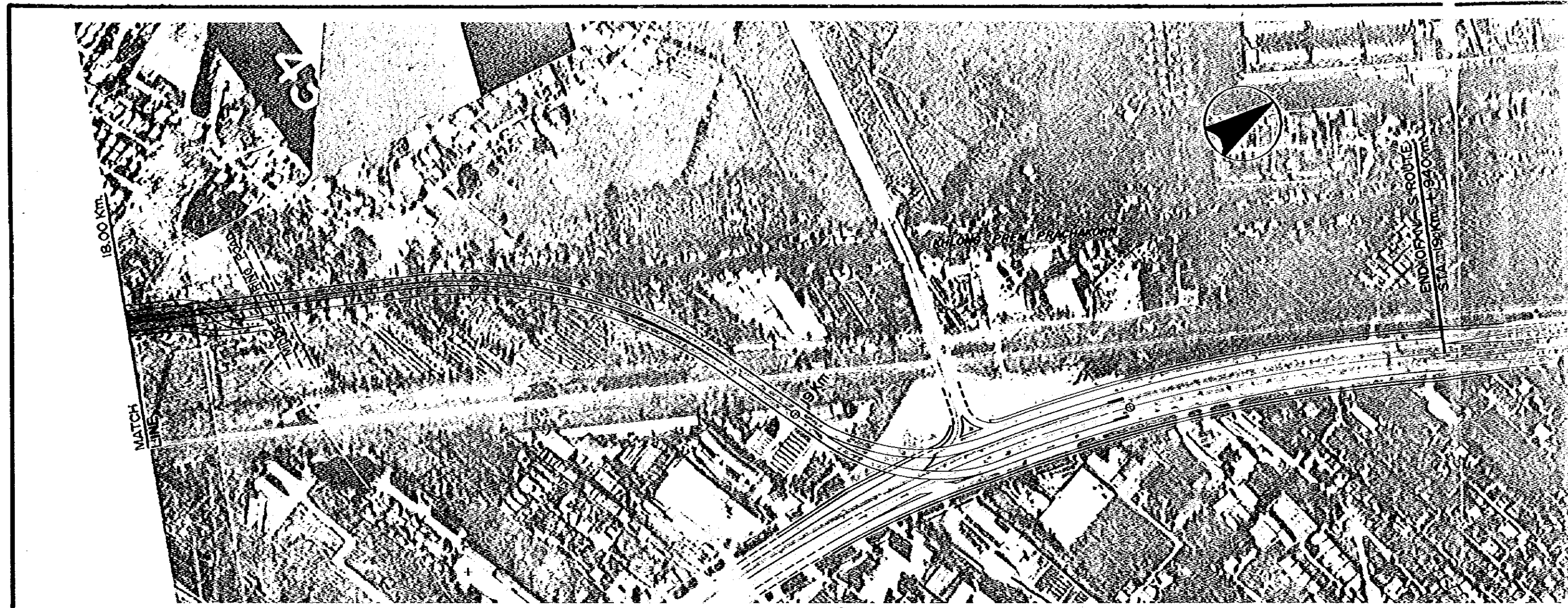

THE SECOND STAGE EXPRESSWAY SYSTEM
IN THE GREATER BANGKOK

SCALE
1 : 500
1 : 5000

N - S ROUTE, PLAN AND PROFILE
(STA. 18 + 000 - STA. 19 + 940)

DWG. No.
10

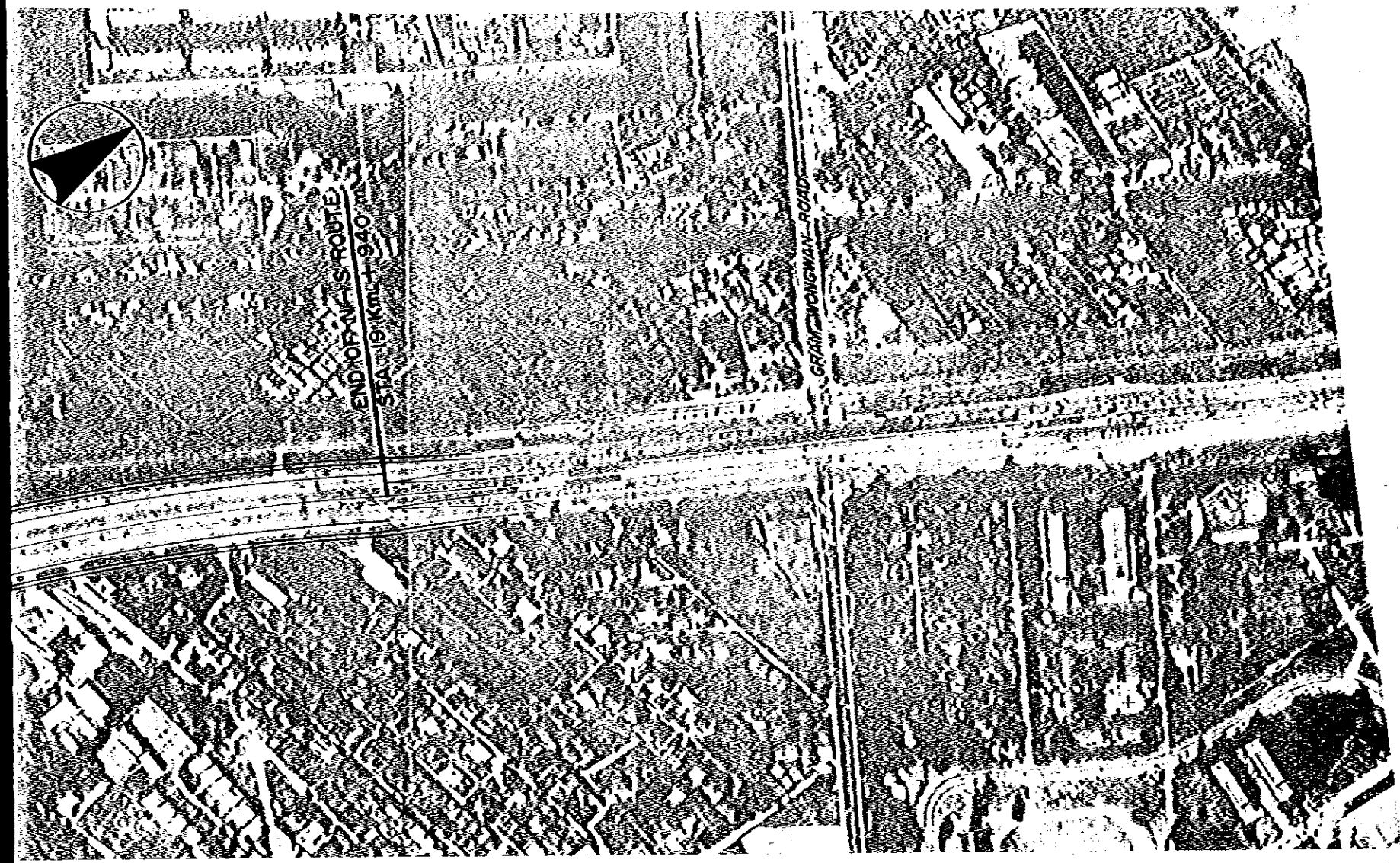

KEY MAP

