

Idea II

2. Result of Study for 50% Capacity of M-BFP

(1) Location

New M-BFP can be installed between existing M-BFP and boiler on the basement floor.

Required floor area is assumed to be same as 50% M-BFP of M-2 (4000 mm x 13,000 mm)

Available height of around 4 m seemed enough.

There are two (2) drainage pit, which should be relocated for new pump but it could not be difficult.

As mentioned above, since there is enough space for new pump foundation and installation works could be carried out even when the plant is in service.

Connection works to the deaerator storage tank and existing pipe line and electrical equipment can be carried out during conventional annual shutdown. There will be no necessary special shutdown for this pump installation.

(2) Regarding the Pipe Size

Existing pipe size is 8 inches. Assumed capacity of new pump will be 590 t/h (half of existing T-BFP capacity).

As indicated below, existing pipe size will not be enough in view of the velocity inside the pipe.

	Suction pipe (schedule 80)			Discharge pipe (schedule 120)		
	8 inch	10 inch	12 inch	8 inch	10 inch	12 inch
Outer dia (mm)	216.3	267.4	318.5	216.3	267.4	318.5
Thickness (mm)	12.7	15.1	17.4	18.2	21.4	25.4
Inner dia. (mm)	190.9	237.2	283.7	179.9	224.6	267.4
Inside Section Area (m ²)	0.0286	0.0442	0.0632	0.0254	0.0396	0.0562
Computed ve- locities(m/s)	5.73	3.71	2.59	6.48	4.14	2.92
Standard Velocity	3.2	3.4	3.6	3.75	3.3	3.6
Use			0			0

(3) Minimum Flow Line

Existing minimum flow line is commonly provided for T-BFP and M-BFP. In case that new 1/2 MCR M-BFP will be installed the existing minimum flow line should be used for T-BFP only and new minimum flow line should be provided for the new 50% M-BFP.

(4) Feedwater Regulating Valve

Capacity of feedwater control valve should be studied for the 50% M-BFP.

Capacity of control valve can be decided after determination of discharge pressure of M-BFP.

Valve size should be determined to have 120% - 140% CV

- 19 -

(Valve coefficient) valve to computed CV valve.

If CV valve is too big, there will be difficulty at low load operation.

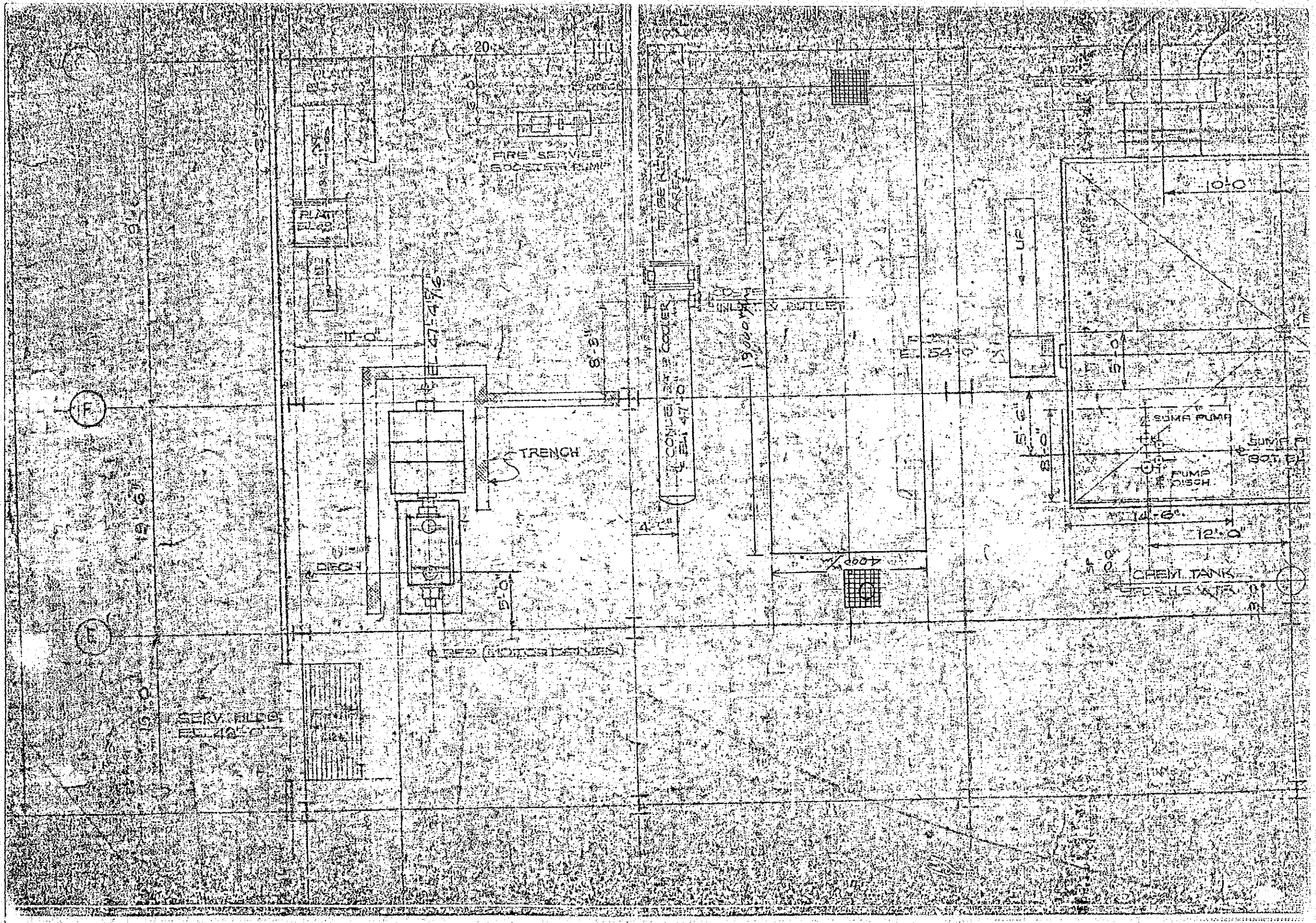

[The page contains extremely faint and illegible text, likely due to low contrast or scanning quality. No specific content can be transcribed.]

STUDY FOR 50% M-BFP FOR ELECTRICAL EQUIPMENT

1. Transformer and 4.160 KV bus capacity

There is enough capacity for 50% M-BFP

2. Voltage drop at motor starting

50% M-BFP should be provided with 2 motors in order not to exceed 15% voltage drops reaches about 17% however, the bus voltage is maintained 5% above the rated voltage so that motor can be started within 15% voltage drop at 4.160 V bus from the rated voltage.

3. Reconstruction to be carried out for 50% M-BFP

(1) Installation of New 4.160 V SWGR unit (to be connected "B" bus by cable)

(2) Cable works for new motors.

Table I - M-1 Transformer and 4.160 V Bus

	Station Service		Emergency Station		Result
Transformer cap (FA)	25,000KVA/12,500 KVA 12500		26600/13,300 ^{KVA} 13,300		O. K.
Present load condition at 150 MW without M-BFP running	Bus A 5.0 MVA (150 MW) Jul. 3'82	Bus B 3.7 MVA Jul. 3'82	Bus C (3.6 MVA) (160 MW) Jul. 5'82	Bus D (5.0 MVA) Jul. 5'82	-
Estimated load with M-BFP running	Bus A 5.0 MVA	Bus B 10.7 MVA	Bus C (10.6 MVA)	Bus D (5.0 MVA)	O. K.
Bus current with M-BFP running	Bus A 720 A (2000 A rating)	Bus B 1,544A	Bus C (1500 A) (2000 A rating)	Bus D (720 A) (2000 A rating)	O. K.

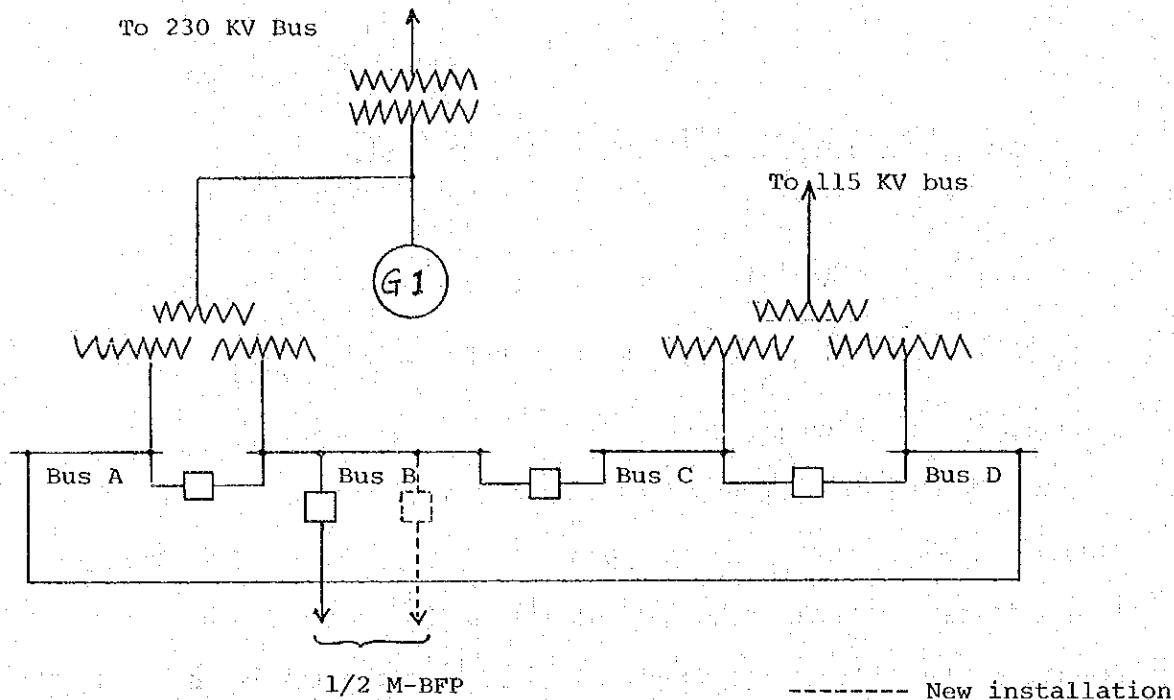

Motor Capacity

4190^{HP} (3124 KW) - - - - - > 530 A - - - - - 1/3 capacity
 (Existing motor)

8000^{HP} (5965 KW) - - - - - > 1013 A - - - - - 1/2 capacity
 (Estimated capacity)

Case I - 1 Pump - 1 Motor (Not applicable)

Voltage Fluctuation at bus B

Load before motor start

$$3,700 \times (0.85 - j 0.526) \quad 0.85 = \text{power factor}$$

Motor Starting

$$\frac{5965 \text{ KW}}{0.85} \times 6 (0.2 + j 0.98) = 42100 \times (0.2 - j0.98)$$

0.2 = power factor at motor starting

Total Load at Motor Starting

$$3,700 \times (0.85 - j0.526) + 42,100 \times (0.2 - j0.98)$$

$$= 11,565 - j43.204.$$

$$\sqrt{11,565^2 + 43,204^2} = 44,724 \text{ KVA } \cos\phi = 0,259$$

Voltage regulation at motor starting

% impedance = 8.6% at 12500 KVA

Voltage regulation at motor starting

$$V = \frac{44,724}{12,500} (R \times 0,259 + X \times 0,966)$$

$$R = 0$$

$$X = 8.6\%$$

$$= \frac{44,724}{12,500} (0 + 8.6 \times 0.966) = 29.7\%$$

Voltage drop must be less than 15% so that case I cannot be applied.

Case 2 - 1 pump - 2 Motors applicable

Load before 2nd motor start

$$(3700 + \frac{5965 \times 1/2}{0.85}) \times (0.85 - j0.526) \quad 0.85 = \text{power factor}$$
$$= 7,209 \times (0.85 - j0.526)$$

Motor starting current

$$\frac{5965 \times 1/2}{0.85} \times 6 \times (0.2 - j0.98) = 21050 \times (0.2 - j0.98)$$

(0.2 = power factor)

Total load at motor starting

$$7209 \times (0.85 - j0.526) + 21050 \times (0.2 - j0.98)$$
$$= 10,338 - j 24,421$$

$$10,338^2 + 24,421^2 = 26,519 \quad \cos\phi = 0.39$$

Voltage regulation at motor starting

% impedance = 8.6% at 12,500 KVA

$$\begin{aligned} V &= \frac{26519}{12,500} (R \times 0.39 + X \times 0.92) \\ &= \frac{26,519}{12,500} \times (0 + 8.6 \times 0.92) \\ &= 16.8\% \end{aligned}$$

Voltage regulation will exceed 15% but bus voltage is maintained by 5% above the rated voltage so that this 2nd motor can be started within 15% voltage drop from the rated voltage.

Idea 3

Relocation of 1/3 M-BFP from S-1

1. Available Capacity of the Unit

Since the existing M-BFP is designed on the condition of 1/3 boiler capacity with pressure of 2950 psi and temperature of 283°F, unit operation at more than 1/3 rating by operating two (2) M-BFP will cause some difficulty in view of temperature and pressure conditions.

2.1 Power Source

There is enough capacity for 1/3 M-BFP as follows:

	A Bus	B Bus
Present condition without M-BFP	6.3 MVA (240 MW)	3.5 MVA (240 MW)
Expected load with M-BFP	9.7 MVA Rating 125 MVA	6.9 MVA Rating 125 MVA

2.2 Reconstruction to be carried out

New switchgear for 1/3 M-BFP and associated cables should be installed on A bus

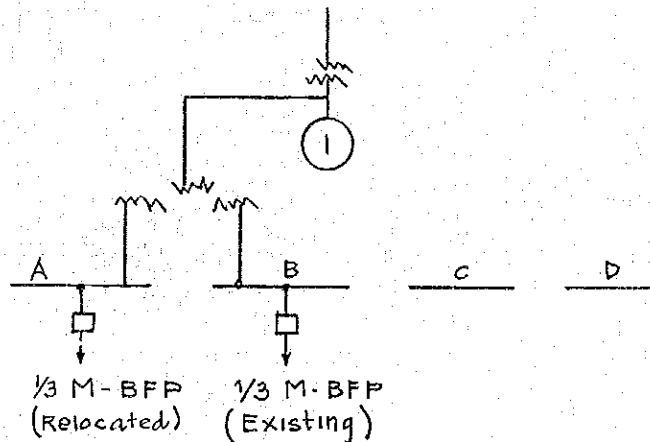

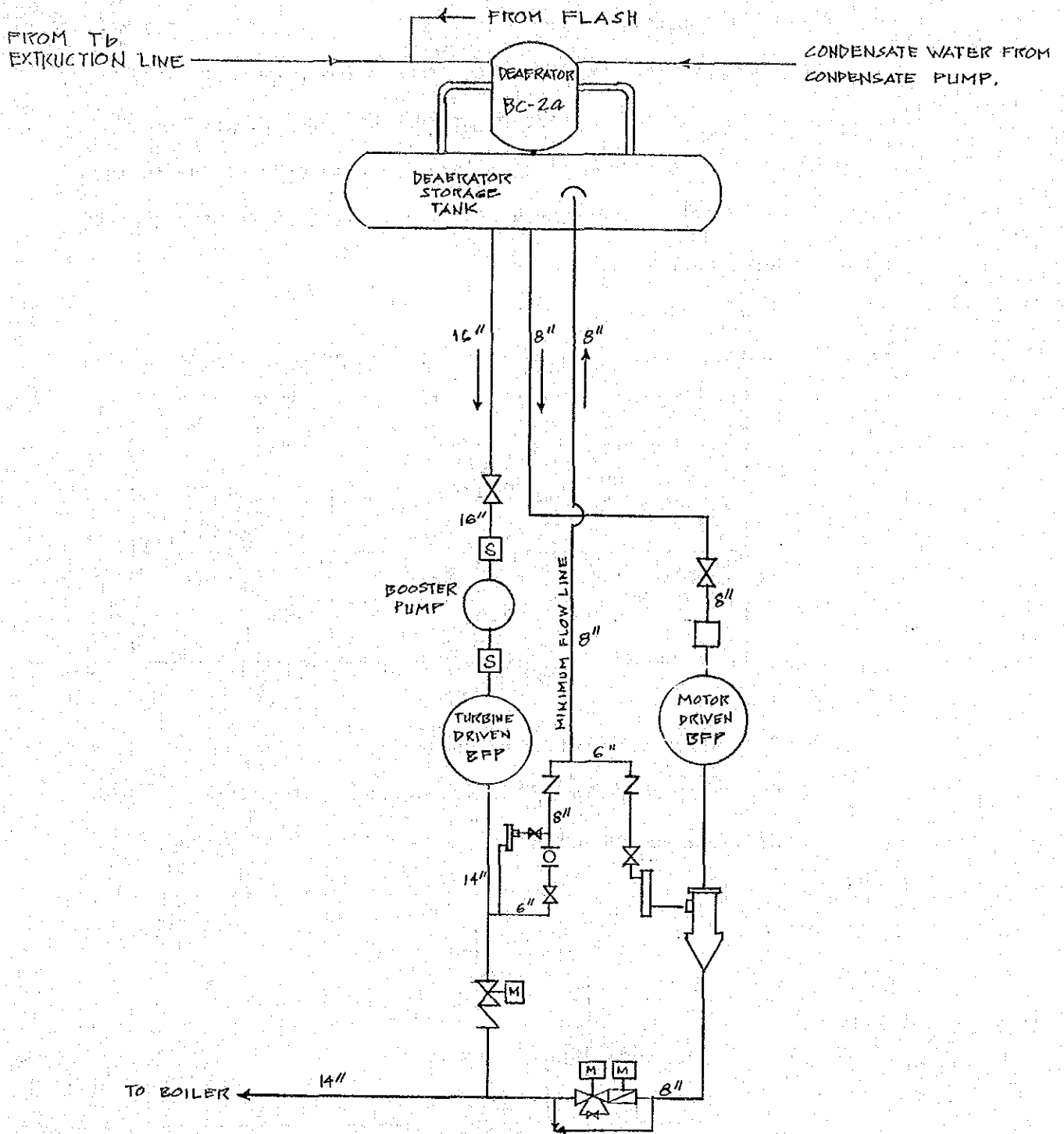

[The page contains extremely faint and illegible text, likely due to low contrast or scanning quality. No specific content can be transcribed.]

JICA