

2-4 Auxiliary Facility

The major auxiliary facility for the management of the production, maintenance and accommodation at the phosphate fertilizer plant is designed to have following specifications;

<u>Facility Specification</u>	
Administration Building	750 m ²
Laboratory	200
Canteen	200
Garage and Gate House	100
Maintenance Shop	1,000
Storage House	1,000
Fire Fighting House	100
Others	-

3. Project Summary

3-1 Product and Production

The proposed granular ground phosphate rock plant project is to produce granular ground phosphate rock in bagged form from phosphate rock and potassium chloride as major inputs.

The brief specification of the product and production is summarized as below:

<u>Product</u>	<u>Fertilizer Specification</u>			<u>Production, Ton</u>	
				<u>Daily</u>	<u>Annual</u>
Granular Ground Phosphate Rock	T-N 0.0	T-P ₂ O ₅ (F-P ₂ O ₅) 33.87(5.40)	W- K ₂ O 3.00	347.4	103,181

The limiting factor for the production is the availability of phosphate rock which is recovered from the non-magnetic tails of HIPASAM, Sierra Grande, Río Negro. The total available phosphate rock is 100,000 TPY and the losses for transportation and handling of 2.0% is reduced for the production calculation.

3-2 Overall Consumption

The overall consumption of raw material, utility, catalysts and chemicals for the proposed project is calculated for the financial analysis of the project which includes losses during storage, processing and bagging of the products, and also the consumption for utility and auxiliary facilities.

	<u>Production and Consumption</u>		
	<u>Unit Product</u>	<u>Hourly</u>	<u>Daily</u>
Production;			
-Granular Ground Phosphate Rock, Bagged, Ton	1.000	14.475	347.4
Consumption;			
-Phosphate Rock (P ₂ O ₅ ;35.65%), Ton	0.9692	14.029	336.7
-Potassium Chloride (W-K ₂ O;60.0%)Ton	0.0515	0.745	17.9
-Electric Power, kwh	55.500	803.36	19,280.7
-Raw Water, Ton	0.250	3.62	86.9
-Natural Gas, MMBTU-LHV	0.555	8.03	192.8
-Fertilizer Bag, 50 kg Net, Sheet	20.200	292.40	7,017.5

3-3 Overall Flow Block Diagram

The overall flow block diagram of the granular ground phosphate fertilizer plant showing process plant, utility and auxiliary facilities are illustrated in Figure AV-2-1.

Raw Material and Utility Input

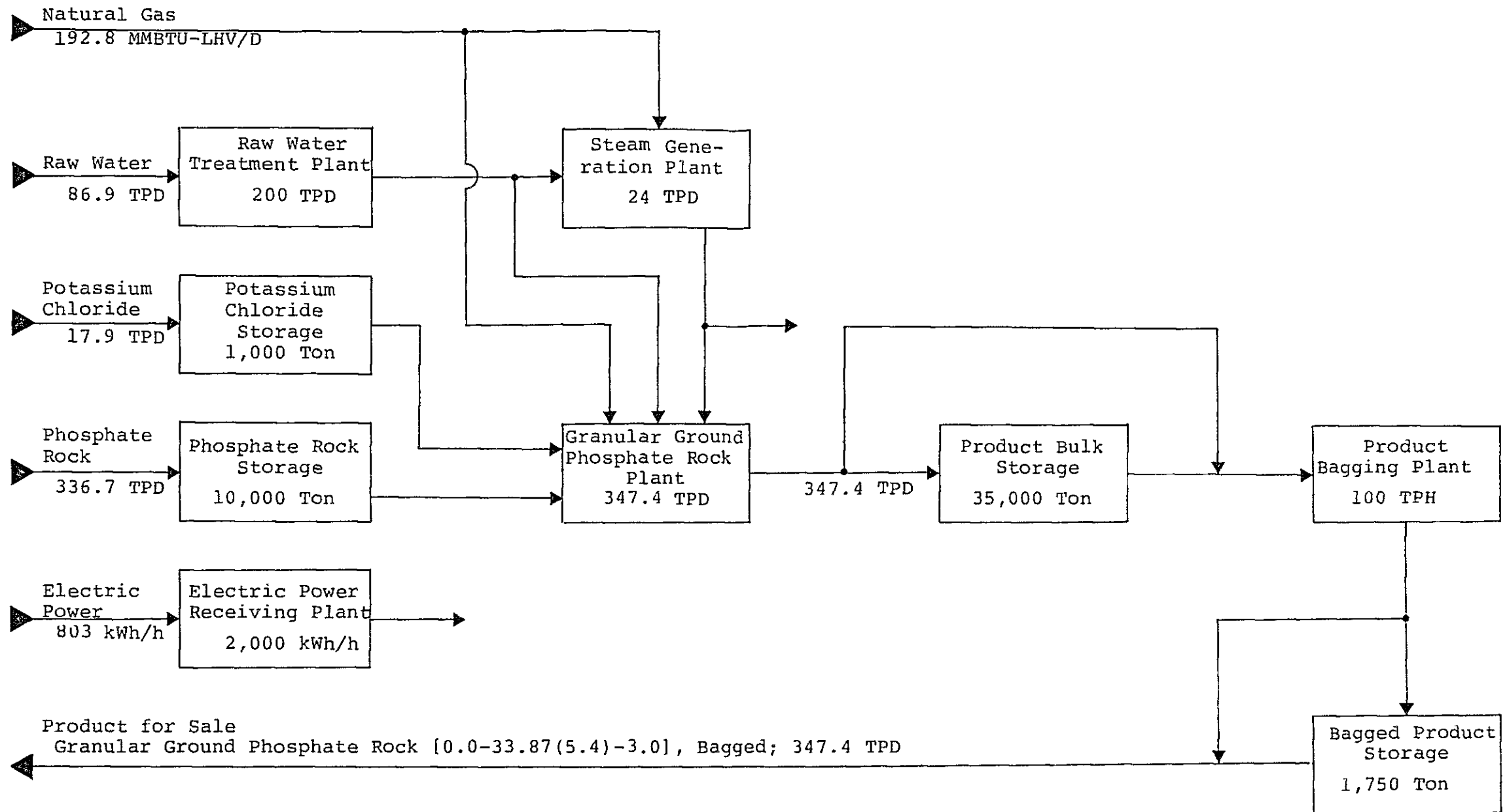

Figure AV-2-1
 BLOCK FLOW DIAGRAM FOR PHOSPHATE FERTILIZER PLANT
 Project: Granular Ground Phosphate Rock Fertilizer Plant ... PF-1
 Feasibility Study: The Establishment of a Phosphate Fertilizer
 Plant in the Argentine Republic. Japan
 International Cooperation Agency. April, 1984

Annex V-3

PROJECT DESCRIPTION FOR PHOSPHATE FERTILIZER PLANT

PF - 2 ... FMP

Fused Magnesium Phosphate Production

PROJECT DESCRIPTION FOR FUSED MAGNESIUM PHOSPHATE PLANT
PF - 2 ... FMP
Fused Magnesium Phosphate Production

1. Project Outline

The proposed phosphate fertilizer plant project is to produce 569.0 TPD of fused magnesium phosphate fertilizer [0.0 - 20.68 (T-P₂O₅), 20.30 (C-P₂O₅) - 0.0] by open hearth furnace process where mixture of phosphate rock and serpentine is heated into molten state by natural gas firing and quenched into jet stream of cooling water to obtain highly soluble P₂O₅ of the product in citric acid solution.

The raw material phosphate rock will be recovered at the phosphate rock concentration plant of non-magnetic tails of HIPASAM, Sierra Grande, Argentine.

Another raw material serpentine is domestically available in Córdoba, Argentine.

The final product is sandy fused magnesium phosphate (FMP) fertilizer in bag, which is considered straight phosphate fertilizer with high content of citric acid soluble P₂O₅, and MgO, SiO₂ and CaO for secondary plant nutrients supply.

The fertilizer standards in Argentine designates the effectiveness of this type of fertilizer, as is applied for Thomas slag phosphate fertilizer, should be evaluated by citric acid soluble phosphate.

The design capacity of the plant is 569.0 TPD of FMP and its annual production in 297 days is 168,993 TPY. The major facility in the project plant is as follows:

Process Plant;

-Fused Magnesium Phosphate 569.0 TPD

Utility Plant;

-Electric Power Receiving 5,000.0 kWh/h
-Natural Gas Receiving 5.0 MMSCFD
-Raw Water Treatment 4,000.0 TPD
-Waste Water Treatment 4,000.0 TPD

Storage and Material Handling Facility

-Phosphate Rock 10,000 Ton
-Product 60,000
-Product Bagging 160 TPH

Auxiliary Facility

-Administration Building 750 m²
-Maintenance Shop and Storage 1,000
-Others -

The total area for the proposed project site is 50,000 m²
(200 m x 250 m)

2. Plant Description

The outline of the process plant, utility plant, storage and material handling facility and auxiliary facility for the production of fused magnesium phosphate is explained hereafter.

2-1 Fused Magnesium Phosphate Plant

(1) Introduction

The process plant for the production of fused magnesium phosphate is to heat and melt the raw material mixture of phosphate rock and serpentine in natural gas fired open hearth furnace. There are two processes available for the commercial production of fused magnesium phosphate fertilizer, namely the electric furnace process and the open hearth furnace process. The selection of the process is mostly determined by the cost comparison between electric power and fuel at the specific project because the investment cost for the two process plants are almost identical.

However, for the proposed project in Argentine which consumes recovered phosphate rock at Sierra Grande, the open hearth furnace process is suitable because the phosphate rock is finely in ground and it is required to make nodules of phosphate rock if it is processed in electric furnace process to prevent the outbreak of dust burst during melting.

Recent process development at open hearth furnace process is to feed raw material mixture into the furnace from the side walls of furnace by piston apparatus and even finely ground phosphate rock is suitable at this type of furnace.

There are three identical trains of open hearth furnace (57,000 TPY per train) for the proposed project but the raw material preparation, product crushing, drying and bagging sections are single trained.

Experimental tests on the applicability of the phosphate rock at FMP production were carried out at Hinode Kagaku Kogyo K.K., Japan and the tests results are incorporated into the conceptual design of the proposed plant as is explained hereunder. The specification of raw material phosphate rock is shown in Table AV-3-1.

(2) Process Description

The raw materials phosphate rock and crushed serpentine are at first weighed continuously and fed into pug mill mixer for feed preparation.

The mixture is transferred into the natural gas fired open hearth furnace through the side walls by piston pushers where the solid material is completely fused at a temperature of 1,350°C. The average retention time of the material in the furnace is approximately three minutes.

The fused product in the open hearth furnace is tapped continuously into water jet stream and quenched glassy particles are formed which is recovered at liquid cyclone and settling tanks.

The drained product is then fed to the rotary drum dryer where natural gas fired hot air is supplied to remove moisture from the product. The dried product is screened and oversized materials are crushed and set to the bulk product storage and bagging plant.

The exhaust gas from the open hearth furnace is sent to the slag chamber and recuperator where the heat of exhaust gas is recovered for combustion air preheating. The final

Table AV-3-1 ANALYSIS OF PHOSPHATE ROCK EXTRACTED FROM IRON ORE CONCENTRATION
NON-MAGNETIC TAILS OF HIPASAM, SIERRA GRANDE, ARGENTINE

(1) CHEMICAL ANALYSIS

As Element	Weight Percent	As Oxide	Weight Percent	Equivalency for 100g Sample
P	15.56%	P ₂ O ₅	35.65%	(-) 1.507
C (Carbonate)	0.09	CO ₂	0.33	(-) 0.015
F	1.50	F	1.50	(-) 0.079
Cl	0.01	Cl	0.01	(-) 0.0005
OH	-	OH	(3.88)	(-) (0.2285)
S (Total)	-	S and Oxides	-	(-) -
S (Sulfide)	0.48	S	0.48	(-) 0.030
S (Sulfate)	-	SO ₃	-	(-) -
Si	1.98	SiO ₂	4.24	(-) 0.141
Fe (Total)	5.80	Fe Oxides	7.67	(+) 0.233
Fe (II)	4.36	FeO	(5.61)	(+) (0.156)
Fe (III)	1.44	Fe ₂ O ₃	(2.06)	(+) (0.077)
Al	1.46	Al ₂ O ₃	2.06	(+) 0.162
Mn	-	MnO	-	(+) -
Ca	31.66	CaO	44.30	(+) 1.580
Mg	0.22	MgO	0.36	(+) 0.018
Na	0.15	Na ₂ O	0.20	(+) 0.006
K	0.07	K ₂ O	0.08	(+) 0.002
Others	-	Others	-	-
Free Moisture	0.14	Free Moisture	0.14	-
Organics	-	Organics	-	-
Ignition Loss	1.68	Ignition Loss	1.68	-
Total	65.95	Sub-total	102.58	(-) 2.001
		Adjustment for F	(-) 0.63	(+) 2.001
		Total	101.95	(+) 0.000

(2) PHYSICAL PROPERTY

Color	Gray
Size Distribution (Tyler Mesh and Millimeter)	
(+) 400 Mesh (0.0370 mm)	15.9%
(+) 468.4 (0.0316)	18.4
(+) 677.8 (0.0219)	36.1
(+) 993.3 (0.0149)	52.5
(+) 1,309.7 (0.0113)	64.5
(-) 1,309.7 (0.0113)	35.4
	100.0
Density	3.27
Bulk Density - Packed	1.67
- Loose	1.27
Angle of Reponse	43.0'
Free Moisture of Filter Cake, %	13.0
Specific Surface Area, cm ² /gr	2,770

(3) FERTILIZER PROPERTY

	Weight Percent	Solubility Percent
Total P ₂ O ₅	35.65%	100.0%
Nitric Acid Soluble P ₂ O ₅	35.60	99.9
Hydrochloric Acid Soluble P ₂ O ₅	35.11	98.5
Citric Acid Soluble P ₂ O ₅	7.96	22.3
Formic Acid Soluble P ₂ O ₅	5.69	16.0
Ammonium Citrate Soluble (AV) P ₂ O ₅ (Neutral)	0.00	0.0
Water Soluble P ₂ O ₅	0.00	0.0

Notes: - Sample tails (Fe=27.53%, P₂O₅=7.08%) were taken on October 6, 1983 at HIPASAM and concentration test and analysis were made at NIKKO Consulting and Engineering Co. Ltd., Japan in January, 1984. Recovery of P₂O₅ is 55.5%. Fertilizer property was determined at Nissan Chemical Industries, Ltd., Japan in March, 1984.

- Ignition loss is measured by heating at 900°C for 0.5 hours.
- Free moisture is measured by heating at 105°C for 5.0 hours.
- (OH) is estimated to keep balanced equivalency.

treatment of the exhaust gas is scrubbing off the fluorine chemicals by water. The waste water is neutralized with lime and calcium fluoride is recovered.

(3) Product Specification

The plant is to produce 569.0 TPD of fused magnesium phosphate fertilizer in bulk under normal operating conditions.

The specification of the product is as follows:

Fused Magnesium Phosphate

Daily Production; 569.0 TPD

Analysis;

-Total P ₂ O ₅	20.68%
-Citric Acid Soluble P ₂ O ₅	20.30
-Formic Acid Soluble P ₂ O ₅	9.27
-Ammonium Citrate (Neutral) Soluble P ₂ O ₅	13.40
-Water Soluble P ₂ O ₅	0.00
-Citric Acid Soluble MgO	15.50
-Citric Acid Soluble SiO ₂	20.50
-Total Alkalinity	50.00
-Moisture	0.30

Conditions;

-Temperature	40.0°C
-Pressure	1.0 ata
-Size Distribution	
(+) 1.0 mm	15.0%
(+) 0.5, (-) 1.0	30.0
(+) 0.1, (-) 0.5	35.0
(-) 0.1	20.0
-Bulk Density	1.55
-Angle of Repose	30.0°
-Crushing Strength (1.0 mm)	20.0 kg

(4) Raw Material, Utility, Chemicals and Catalysts Consumption

The consumption of raw material and utility for the production of fused magnesium phosphate fertilizer under normal operating conditions is as follows:

	<u>Production and Consumption</u>		
	<u>Unit Product</u>	<u>Hourly</u>	<u>Daily</u>
Production;			
-Fused Magnesium Phosphate, Bulk, Ton	1.0000	23.708	569.0
Consumption:			
-Phosphate Rock (P ₂ O ₅ ; 35.65%), Ton	0.5858	13.8873	333.3
-Serpentine (MgO; 35.60%), Ton	0.498	11.10	283.4
-Natural Gas, MMBTU-LHV	5.67	134.42	3,226.2
-Open Hearth Furnace	(5.10)	(120.91)	(2,901.9)
-Product Dryer	(0.57)	(13.51)	(324.3)
-Electric Power, kWh	130.00	3,082.04	73,969.0
-Raw Water, Ton	4.00	94.83	2,276.0
-Brick for Repair, Ton	0.01	0.24	5.7
-Lime for Waste Water Treatment, Ton	0.02	0.47	11.4

2-2 Utility Plant

The major utility plants for the fused magnesium phosphate plant are as follows:

	<u>Facility capacity</u>	<u>Normal Demand</u>
Electric Power Receiving, kWh/h	5,000.0	3,674.7
Natural Gas Receiving, MMSCFD	5.0	3.8
Raw Water Treatment, TPD	4,000.0	3,186.4
Plant and Instrument Air, Nm ³ /h	20.0	15.0
Waste Water Treatment, TPD	4,000.0	3,000.0

2-3 Storage and Material Handling Facility

The major facility for raw material, intermediates and product receiving, storage, bagging and other material handlings are designed to have following capability:

	<u>Facility capacity</u>	<u>Normal Demand</u>
Storage Facility;		
-Phosphate Rock, Ton	10,000	336.7 TPD
-Serpentine, (Open Yard), Ton	2,900	290.0
-Product, Bulk, Ton	57,000	569.0 TPD
Bagged, Ton	3,000	569.0
Bagging and Loading Facility;		
-Product, TPH	160	23.7

2-4 Auxiliary Facility

The major auxiliary facility for the management of the production, maintenance and accommodation at the phosphate fertilizer plant is designed to have following specifications;

Facility Specification

Administration Building	750 m ²
Laboratory	200
Canteen	200
Garage and Gate House	100
Maintenance Shop	1,000
Storage House	1,000
Fire Fighting House	100
Others	-

3. Project Summary

3-1 Product and Production

The proposed fused magnesium phosphate fertilizer plant project is to produce fused magnesium phosphate fertilizer in bagged form from phosphate rock and serpentine as major inputs.

The brief specification of the product and production is summarized as below:

<u>Product</u>	<u>Fertilizer Specification</u>				<u>Production, Ton</u>	
	<u>T-</u> <u>N</u>	<u>T-</u> <u>P₂O₅</u>	<u>(C-</u> <u>P₂O₅)</u>	<u>W-</u> <u>K₂O</u>	<u>Daily</u>	<u>Annual</u>
-Fused Magnesium Phosphate	0.0	20.68(20.30)		0.0	569.0	168,993

The limiting factor for the production is the availability of phosphate rock which is recovered from the non-magnetic tails of HIPASAM, Sierra Grande, Río Negro. The total available phosphate rock is 100,000 TPY and the losses for transportation and handling of 2.0% is reduced for the production calculation.

3-2 Overall Consumption

The overall consumption of raw material, utility, catalysts and chemicals for the proposed project is calculated for the financial analysis of the project which includes losses during storage, processing and bagging of the products, and also the consumption for utility and auxiliary facilities.

	<u>Production and Consumption</u>		
	<u>Unit Product</u>	<u>Hourly</u>	<u>Daily</u>
Production;			
-Fused Magnesium Phosphate,	1.000	23.708	569.0
Consumption;			
-Phosphate Rock (P ₂ O ₅ ; 35.65%), Ton	0.5917	14.03	336.7
-Serpentine (MgO: 35.60%) Ton	0.5080	12.04	289.0
-Electric Power, kWh	155.50	3,674.74	88,193.8
-Raw Water, Ton	5.60	132.76	3,186.4
-Natural Gas, MMBTU-LHV	6.050	143.43	3,442.4
-Brick for Repair*, Ton	0.01	0.24	5.7
-Lime for Waste Water Treatment*, Ton	0.02	0.47	11.4
-Fertilizer Bag, 50 kg Net, Sheet	20.20	478.90	11,493.6

* Cost for these materials is USD 1.25 (CIF)/Ton of product FMP on the date of base cost estimate

3-3 Overall Flow Block Diagram

The overall flow block diagram of the fused magnesium phosphate plant showing process plant, utility and auxiliary facilities are illustrated in Figure AV-3-1.

Raw Material and Utility Input

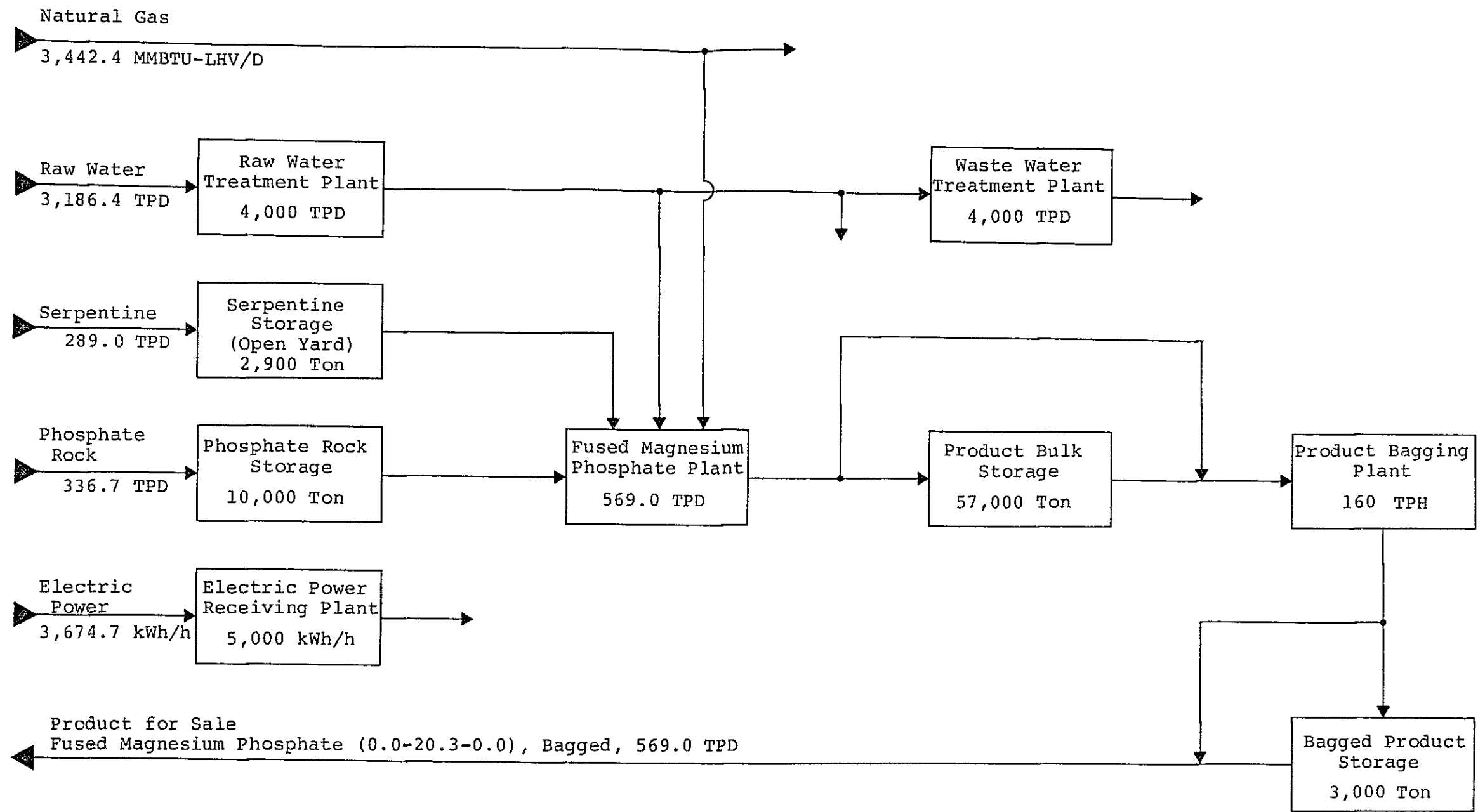

Figure AV-3-1
 BLOCK FLOW DIAGRAM FOR PHOSPHATE FERTILIZER PLANT
 Project: Fused Magnesium Phosphate Fertilizer Plant ... PF-2
 Feasibility Study: The Establishment of a Phosphate Fertilizer Plant in the Argentine Republic. Japan International Cooperation Agency. April, 1984

Annex V-4

PROJECT DESCRIPTION FOR PHOSPHATE FERTILIZER PLANT

PF - 3 ... SSP

Single Super Phosphate Production

PROJECT DESCRIPTION FOR PHOSPHATE FERTILIZER PLANT
PF - 3 ... SSP

Single Super Phosphate Production

1. Project Outline

The proposed phosphate fertilizer plant project is to produce 572 TPD of single super phosphate (SSP) fertilizer [0.0 - 20.57 (T-P₂O₅), 10.70 (W-P₂O₅)-0.0] by den acidulation and granulation process from phosphate rock, and sulfuric acid which is produced in the plant from imported sulfur.

The raw material phosphate rock will be recovered at the phosphate rock concentration plant of non-magnetic tails at HIPASAM, Sierra Grande, Argentine and sulfur will be imported from the USA, Canada or Mexico because there is no available sulfur source identified in Argentine at present.

Due to the low reactivity of phosphate rock, the available phosphate in the product, measured by neutral ammonium citrate solution is 78% (P₂O₅; 16.04% in product) and water soluble phosphate is 52% (P₂O₅; 10.70% in product) against total P₂O₅ which are both considerably lower than the conventional single super phosphate. The residual free acid in the final product is also high.

The fertilizer standards in Argentine designates the effectiveness of single super phosphate should be measured by total and water soluble phosphate and the minimum figures required are 19.5 and 18.0% as P₂O₅, respectively.

The optimum operating conditions, product quality and its process consumption were found by the small scale tests (0.20 kg/Batch) at Nissan Chemical Industries, Ltd., Japan by using recovered phosphate rock from the non-magnetic tails of HIPASAM, Sierra Grande.

The experimental results are incorporated into the conceptual design of the SSP fertilizer plant project as is explained hereunder.

The design capacity of the plant is 572.0 TPD of SPP and its annual production in 297 days is 169,884 TPY.

The major facility in the project plant is as follows:

Process Plant;

-Sulfuric Acid	195.5 TPD
-Single Super Phosphate	572.0

Utility Plant;

-Electric Power Receiving	2,000 kWh/h
-Natural Gas Receiving	5 MMSCFD
-Raw Water Treatment	500 TPD
-Cooling Water Tower	14,400
-Waste Water Treatment	500 TPD
-Steam Generation	5 TPH

Storage and Material Handling Facility;

-Phosphate Rock	10,000 Ton
-Sulfur	2,000
-Sulfuric Acid	1,000
-Product	60,000
-Product Bagging	160 TPH

Auxiliary Facility;

-Administration Building	750 m ²
-Maintenance Shop and Storage	1,000
-Others	-

Total area for the project site is 50,000 m² (200m x 250m).

2. Plant Description

The outline of the process plant, utility plant, storage and material handling facility for the production of single super phosphate (SSP) are described hereunder.

2-1 Sulfuric Acid

(1) Introduction

Sulfuric acid is produced by catalytic oxidation of sulfur dioxide gas which is produced by combustion of sulfur. The sulfur trioxide gas is absorbed in weak sulfuric acid to produce concentrated sulfuric acid.

The production capacity of the process plant is 195.5 TPD as 100% H₂SO₄ which is captively consumed for the production of single super phosphate fertilizer at the plant. The raw material sulfur is imported.

(2) Process Description

The stoichiometric reaction for the production of sulfuric acid is;

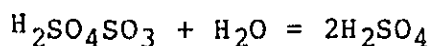
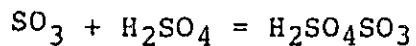
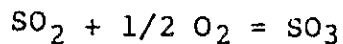
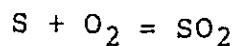

Raw material solid sulfur is melted and purified in the sulfur pit where steam heating is applied to produce molten sulfur which is pumped up to the sulfur furnace.

The pumped sulfur is sprayed through atomizing nozzles of the burner guns. The combustion air is supplied to make vigorous vortex for complete burning of sulfur.

Approximately 10 vol% of SO_2 gas is generated at the sulfur furnace and gas cooling is accomplished in the waste heat boiler before fed to the converter.

The converter consists of four catalyst layers. The first three layers are primary conversion and the last one is for secondary conversion stage. Each conversion stage is followed by primary and secondary absorption steps, respectively.

The reaction heat at the first catalyst layer is removed in the first heat exchanger for cooling down its temperature for reaction at second layer. The reaction heat at the second layer is removed in the superheater by which saturated steam from the waste heat boiler is superheated (30 atg) for steam production.

The reaction heat at the third catalyst layer is also removed in the second and third heat exchangers for absorbing SO_3 efficiently in the first absorbing tower.

The gas from the first absorbing tower is led to the secondary conversion stage, via the second and third heat exchangers to raise its temperature for further conversion of SO_2 to SO_3 .

The final conversion is accomplished in the fourth catalyst layer and overall conversion rate reaches more than 99.7%. The converted gas goes to the second absorbing tower through the economizer in which excess heat is recovered by heating the boiler feed water.

In the first and second absorbing tower, SO_3 is absorbed into circulating 98.5% sulfuric acid. On the contrary, atmospheric air for process use is dried in the drying tower by scrubbing with 94% sulfuric acid.

All the circulating acid is cooled by the acid coolers. The product acid is delivered from the circulating line of second absorbing tower, and after cooled by the product cooler, sent to the acid storage tanks.

Double absorption process provided conversion efficiency of 99.5% for sulfur to sulfuric acid, thus SO_2 loss is lower. The by-product steam is effectively utilized at the single super phosphate fertilizer plant.

(3) Product Specification

The process plant is to produce 195.5 TPD (as 100% H_2SO_4) of sulfuric acid in bulk under normal operating conditions.

The specification of the product is as follows:

Sulfuric Acid;	
-Daily Production (as H_2SO_4)	195.5 TPD
-Analysis	
- H_2SO_4	98.0%
-Moisture	2.0
-Condition	
-Temperature	40 °C
-Pressure	1.0 ata

(4) Raw Material, Utility, Chemicals and Catalysts Consumption

The consumption of raw material and utility for the production of sulfuric acid under normal conditions is as follows:

	<u>Production and Consumption</u>		
	<u>Unit Product</u>	<u>Hourly</u>	<u>Daily</u>
Production;			
-Sulfuric Acid (as H ₂ SO ₄), Ton	1.000	8.146	195.5
Consumption;			
-Sulfur, Ton	0.331	2.70	64.7
-Cooling Water, Ton	45.500	370.64	8,895.4
-Boiler Feed Water, Ton	1.350	1.00	263.9
-Electric Power, kWh	62.500	509.13	12,219.0
-Steam (30 atg, Export), Ton	1.250	10.18	244.3
-Catalyst, liter*	0.0175	0.14	3.4

* The consumption of catalysts and chemicals are equivalent to USD 0.25 (CIF)/Ton of sulfuric acid on the date of base project cost estimate.

2-2 Single Super Phosphate Plant

(1) Introduction

The single super phosphate is produced by direct reaction between phosphate rock and sulfuric acid. The reaction product is then granulated and dried to obtain granular single super phosphate.

The production capacity of the process plant is 572.0 TPD of single super phosphate (SSP) of which analysis is [0.0 - 20.57 (10.70)-0.0].

(2) Process Description

The typical stoichiometric reaction of single super phosphate production is as follows:

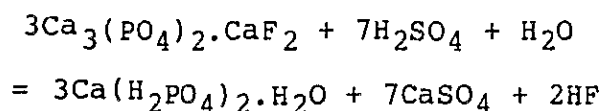

The phosphate rock and sulfuric acid (70% H_2SO_4) are first brought together in a corn-type mixer and then further mixed completely in a puddler. The mixture flows from the puddler into a slow moving slat conveyor which is served as acidulation den. The retention time in the den is approximately 30 minutes for reaction completion.

The material has hardened in the den and is disintegrated at the end of moving den by rotating cutter. The material is further processed at pugmill type granulator with water, steam and recycle fines. The product from the pugmill is dried at a rotary drum dryer where steam heated hot air is supplied co-currently and the dried product is screened before going to the the bulk storage. The dust and fume gas from the process plant is treated at scrubbers. The specification of phosphate rock is shown in Table AV-4-1.

Table AV-4-1 ANALYSIS OF PHOSPHATE ROCK EXTRACTED FROM IRON ORE CONCENTRATION
NON-MAGNETIC TAILS OF HIPASAM, SIERRA GRANDE, ARGENTINE

(1) CHEMICAL ANALYSIS

As Element	Weight Percent	As Oxide	Weight Percent	Equivalency for 100g Sample
P	15.56%	P ₂ O ₅	35.65%	(-) 1.507
C (Carbonate)	0.09	CO ₂	0.33	(-) 0.015
F	1.50	F	1.50	(-) 0.079
Cl	0.01	Cl	0.01	(-) 0.0005
OH	-	OH	(3.88)	(-) (0.2285)
S (Total)	-	S and Oxides	-	(-) -
S (Sulfide)	0.48	S	0.48	(-) 0.030
S (Sulfate)	-	SO ₃	-	(-) -
Si	1.98	SiO ₂	4.24	(-) 0.141
Fe (Total)	5.80	Fe Oxides	7.67	(+) 0.233
Fe (II)	4.36	FeO	(5.61)	(+) (0.156)
Fe (III)	1.44	Fe ₂ O ₃	(2.06)	(+) (0.077)
Al	1.46	Al ₂ O ₃	2.06	(+) 0.162
Mn	-	MnO	-	(+) -
Ca	31.66	CaO	44.30	(+) 1.580
Mg	0.22	MgO	0.36	(+) 0.018
Na	0.15	Na ₂ O	0.20	(+) 0.006
K	0.07	K ₂ O	0.08	(+) 0.002
Others	-	Others	-	-
Free Moisture	0.14	Free Moisture	0.14	-
Organics	-	Organics	-	-
<u>Ignition Loss</u>	<u>1.68</u>	<u>Ignition Loss</u>	<u>1.68</u>	-
Total	65.95	Sub-total	102.58	(-) 2.001
		Adjustment for F	(-) 0.63	(+) 2.001
		Total	101.95	(+) 0.000

(2) PHYSICAL PROPERTY

Color	Gray
Size Distribution (Tyler Mesh and Millimeter)	
(+) 400 Mesh (0.0370 mm)	15.9%
(+) 468.4 (0.0316)	18.4
(+) 677.8 (0.0219)	36.1
(+) 993.3 (0.0149)	52.5
(+) 1,309.7 (0.0113)	64.5
(-) 1,309.7 (0.0113)	35.4
	100.0
Density	3.27
Bulk Density - Packed	1.67
- Loose	1.27
Angle of Reponse	43.0°
Free Moisture of Filter Cake, %	13.0
Specific Surface Area, cm ² /gr	2,770

(3) FERTILIZER PROPERTY

	Weight Percent	Solubility Percent
Total P ₂ O ₅	35.65%	100.0%
Nitric Acid Soluble P ₂ O ₅	35.60	99.9
Hydrochloric Acid Soluble P ₂ O ₅	35.11	98.5
Citric Acid Soluble P ₂ O ₅	7.96	22.3
Formic Acid Soluble P ₂ O ₅	5.69	16.0
Ammonium Citrate Soluble (AV) P ₂ O ₅ (Neutral)	0.00	0.0
Water Soluble P ₂ O ₅	0.00	0.0

Notes: - Sample tails (Fe=27.53%, P₂O₅=7.08%) were taken on October 6, 1983 at HIPASAM and concentration test and analysis were made at NIKKO Consulting and Engineering Co. Ltd., Japan in January, 1984. Recovery of P₂O₅ is 55.5%. Fertilizer property was determined at Nissan Chemical Industries, Ltd., Japan in March, 1984.

- Ignition loss is measured by heating at 900°C for 0.5 hours.
- Free moisture is measured by heating at 105°C for 5.0 hours.
- (OH) is estimated to keep balanced equivalency.

(3) Product Specification

The process plant is to produce 572.0 TPD of single super phosphate in bulk under normal operating conditions.

The specification of the product is as follows:

Single Super Phosphate;

-Daily Production	572.0 TPD
-Analysis	
-Total P ₂ O ₅	20.57%
-Available P ₂ O ₅	16.04
-Water Soluble P ₂ O ₅	10.70
-Free Acid as P ₂ O ₅	4.00
-Moisture	9.00
-Condition	
-Size Distribution	
(+) 3.0 m	5.0%
(-) 3.0, (+) 1.0	90.0
(-) 1.0	5.0
-Bulk Density	1.0
-Angle of Repose	32 °
-Crushing Strength (3.0 mm)	1.5 kg
-Temperature	40 °C
-Pressure	1.0 ata

(4) Raw Material, Utility, Chemicals and Catalysts Consumption

The consumption of raw material and utility for the production of granular single super phosphate fertilizer under normal operating conditions is as follows:

	<u>Production and Consumption</u>		
	<u>Unit Product</u>	<u>Hourly</u>	<u>Daily</u>
Production;			
-Single Super Phosphate, Ton	1.0000	23.834	572.0
Consumption;			
-Phosphate Rock (P ₂ O ₅ ; 35.65%), Ton	0.5828	13.890	333.3
-Sulfuric Acid (H ₂ SO ₄ ; 100%), Ton	0.3384	8.07	193.6
-Raw Water, Ton	3.550	84.61	2,030.7
-Steam, Ton	0.176	4.20	100.7
-Electric Power, kWh	35.000	834.19	20,020.6

2-2 Utility Plant

The major utility plants for the single super phosphate fertilizer plant are as follows:

	<u>Facility Capacity</u>	<u>Normal Demand</u>
Electric Power Receiving, kWh/h	2,000	1,650
Natural Gas Receiving, MMSCFD	5.0	-
Raw Water Treatment, TPD	3,000	2,517
Waste Water Treatment, TPD	500	-
Steam Generation, TPH	5.0	-
Cooling Water Tower, TPH	600	370

2-3 Storage and Material Handling Facility

The major facility for raw material, intermediates and production receiving, storage, bagging and other material handlings are desinged to have following capability:

	<u>Facility Capacity</u>	<u>Normal Demand</u>
Storage Facility;		
-Phosphate Rock, Ton	10,000	336.7 TPD
-Sulfur, Ton	2,000	66.0
-Sulfuric Acid, Ton	1,000	195.5
-Product, Bulk, Ton	57,000	572.0
Bagged, Ton	3,000	572.0
Bagging and Loading Facility;		
-Product, TPH	160	23.8

2-4 Auxiliary Facility

The major auxiliary facility for the management of the production, maintenance and accommodation at the single super phosphate fertilizer plant is designed to have following specifications;

	<u>Facility Specification</u>
Administration Building	750 m ²
Laboratory	200
Canteen	200
Garage and Gate House	100
Maintenance Shop	1,000
Storage House	1,000
Fire Fighting House	100
Others	-

3. Project Summary

3-1 Product and Production

The proposed single super phosphate fertilizer plant project is to produce granular single super phosphate fertilizer in bagged form from phosphate rock and sulfur as major inputs.

The brief specification of the product and production is summarized as follows:

<u>Product</u>	<u>Fertilizer Specification</u>				<u>Production, Ton</u>	
		T-	W-	W-	<u>Daily</u>	<u>Annual</u>
	<u>T-N</u>	<u>P₂O₅</u>	<u>P₂O₅</u>	<u>K₂O</u>		
Granular Single Super Phosphate, Bagged	0.0	20.57	10.70	0.0	572.0	169,884

The limiting factor for the production is the availability of phosphate rock which is recovered from the non-magnetic tails of HIPASAM, Sierra Grande, Rio Negro. The total available phosphate rock is 100,000 TPY and the loss for transportation and handling of 2.0% is reduced for the production calculation.

3-2 Overall Consumption

The overall consumption of raw material, utility, catalysts and chemicals for the proposed project is calculated for the financial analysis of the project which includes losses during storage, processing and bagging of the product and also of the consumption for utility and auxiliary facilities.

	<u>Production and Consumption</u>		
	<u>Unit Product</u>	<u>Hourly</u>	<u>Daily</u>
Production:			
-Granular Single Super phosphate, Bagged, Ton	1.0000	23.835	572.0
Consumption:			
-Phosphate Rock, Ton	0.5886	14.029	336.7
-Sulfur, Ton	0.1154	2.750	66.0
-Electric Power, Ton	69.2288	1,650.00	39,600.0
-Raw Water, Ton	4.4014	105.00	2,517.8
-Natural Gas, MMBTU-LHV	-	-	-
-Fertilizer Bag, 50 kg Net, Sheet	20.20	281.46	11,554.7
-Catalysts and Chemicals, USD - 1983	0.275	5.55	157.3

3-3 Overall Flow Block Diagram

The overall flow block diagram of the single super phosphate plant showing process plant, utility and auxiliary facilities are illustrated in Figure AV-4-1.

Raw Material and Utility Input

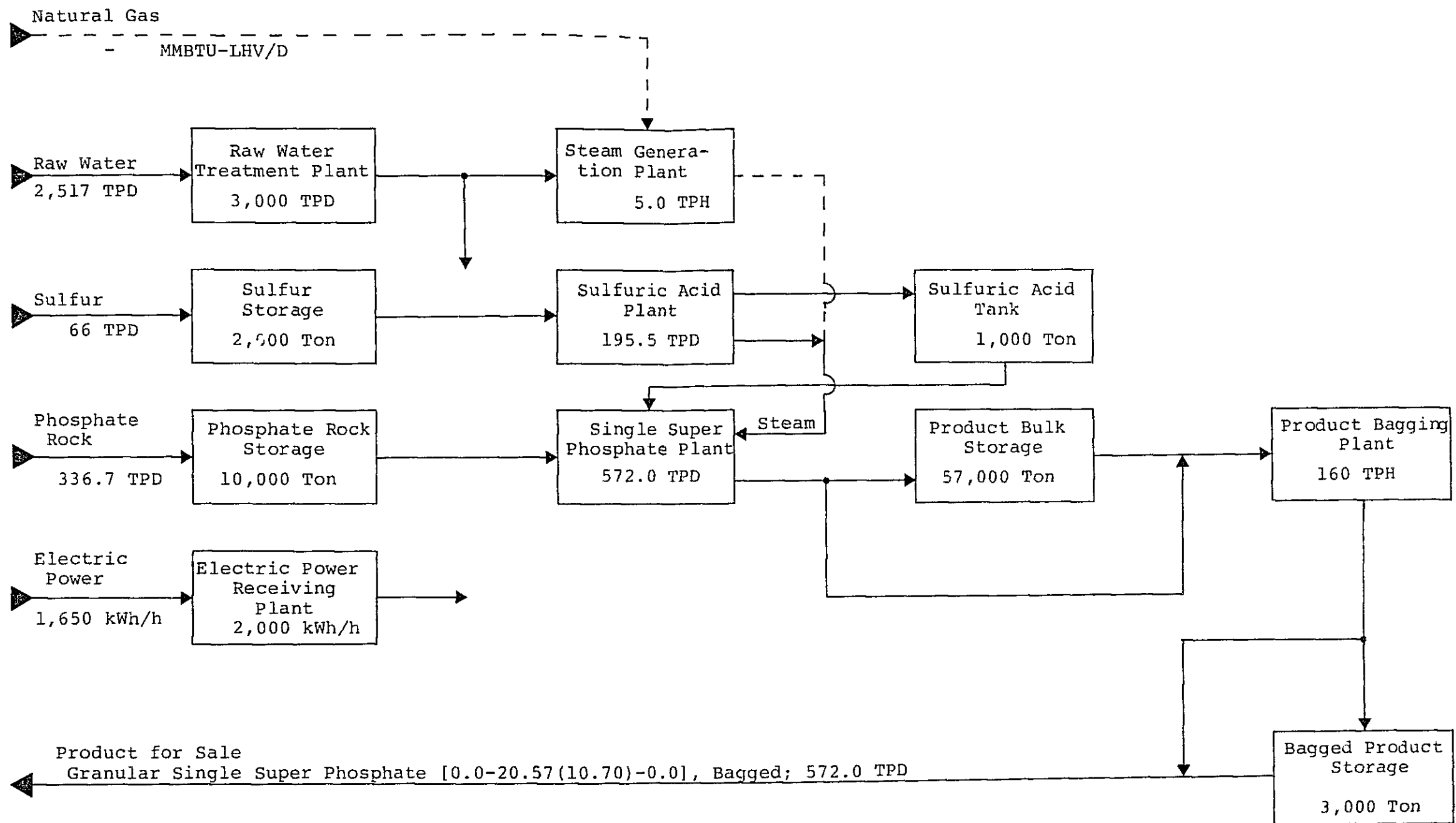

Figure AV-4-1
 BLOCK FLOW DIAGRAM FOR PHOSPHATE FERTILIZER PLANT
 Project: Granular Single Super Phosphate Fertilizer Plant ... PF-3
 Feasibility Study: The Establishment of a Phosphate Fertilizer
 Plant in the Argentine Republic. Japan
 International Cooperation Agency. April, 1984

Annex V-5

PROJECT DESCRIPTION FOR PHOSPHATE FERTILIZER PLANT

PF - 4 ... TSP

Triple Super Phosphate Production

PROJECT DESCRIPTION FOR PHOSPHATE FERTILIZER PLANT
PF - 4 ... TSP

Triple Super Phosphate Production

1. Project Outline

The proposed phosphate fertilizer plant project is to produce 243.3 TPD of triple super phosphate (TSP) fertilizer [0.0-47.33 (T-P₂O₅), 31.00 (W-P₂O₅) - 0.0] by acidulation and granulation process from phosphate rock and phosphoric acid which is produced in the plant from imported sulfur and phosphate rock.

The raw materials phosphate rock will be recovered at the phosphate rock concentration plant of non-magnetic tails of HIPASAM, Sierra Grande, Argentine and sulfur will be imported from USA, Canada or Mexico because there is no available sulfur source identified in Argentine at present.

Due to the low reactivity of phosphate rock, the available phosphate in the product, measured by neutral ammonium citrate solution is 75% (35.5% in product) and water soluble phosphate is 65.5% (31.0% in product) against total P₂O₅ which are both considerably lower than the conventional triple super phosphate. The residual free acid in the final product is also high.

The fertilizer standards in Argentine designates the effectiveness of triple super fertilizer should be measured by total and water soluble phosphate and the minimum figures required are 45.0% and 40.0% as P₂O₅, respectively.

The optimum operating conditions, product quality and its process consumption were found by the small scale tests (0.20kg/Batch) of recovered phosphate rock from the

non-magnetic tails of HIPASAM, Sierra Grande, Argentine. The recovery of P_2O_5 at phosphoric acid is 97.5% at filter acid and 97.0% at concentrated acid. The concentration of filter acid is 30.0% of P_2O_5 and higher residual sulfuric acid is required to increase P_2O_5 recovery. The experimental tests were carried out at Nissan Chemical Industries, Ltd., Japan. and the results are incorporated into the conceptual design of TSP plant as is explained hereunder.

The design capacity of the plant is 243.3 TPD of TSP and its annual production in 297 days is 72,260 TPY.

The major facility in the plant is as follows:

Process Plant;

-Sulfuric Acid	191.5 TPD
-Phosphoric Acid as P_2O_5	81.9
-Triple Super Phosphate	243.3

Utility Plant;

-Electric Power Receiving	2,000 kWh/h
-Natural Gas Receiving	5 MMSCFD
-Raw Water Treatment	2,000 TPD
-Cooling Water Tower	14,400
-Waste Water Treatment	1,000 TPD
-Steam Generation	5 TPH

Storage and Material Handling Facility;

-Phosphate Rock	10,000 Ton
-Sulfur	2,000
-Sulfuric Acid	1,000
-Product	26,000
-Product Bagging	70 TPH

Auxiliary Facility

-Administration Building	1,000 m ²
-Maintenance Shop and Storage	2,400
-Others	

The total area for the project site is 112,500 m² (375m x 300m).

2. Plant Description

The outline of the process plant, utility plant, storage and material handling facility for the production of triple super phosphate (TSP) are described hereafter.

2-1 Sulfuric Acid Plant

(1) Introduction

The sulfuric acid is produced by catalytic oxidation of sulfur dioxide gas which is produced by combustion of sulfur. The sulfur trioxide gas is absorbed in weak sulfuric acid to produce concentrated sulfuric acid.

The production capacity of the process plant is 191.5 TPD as 100% H₂SO₄ which is captively consumed for the production of triple super phosphate fertilizer at the plant. The raw material sulfur is imported.

(2) Process Description

The stoichiometric reaction for the production of sulfuric acid is;

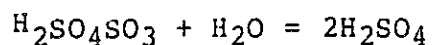
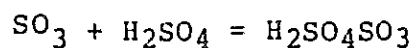
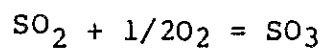
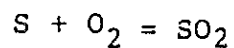

Raw material solid sulfur is melted and purified in the sulfur pit where steam heating is applied to produce molten sulfur which is pumped up to the sulfur furnace.

The pumped sulfur is sprayed through atomizing nozzles of the burner guns. The combustion air is supplied to make vigorous vortex for complete burning of sulfur.

Approximately 10 vol% of SO_2 gas is generated at the sulfur furnace and gas cooling is accomplished in the waste heat boiler before fed to the converter.

The converter consists of four catalyst layers. The first three layers are primary conversion and the last one is for secondary conversion stage. Each conversion stage is followed by primary and secondary absorption steps, respectively.

The reaction heat at the first catalyst layer is removed in the first heat exchanger for cooling down its temperature for reaction at second layer.

The reaction heat at the second layer is removed in the superheater by which saturated steam from the waste heat boiler is superheated (30 atg) for steam production.

The reaction heat at the third catalyst layer is also removed in the second and third heat exchangers for absorbing SO_3 efficiently in the first absorbing tower.

The gas from the first absorbing tower is led to the secondary conversion stage, via the second and third heat exchangers to raise its temperature for further conversion of SO_2 to SO_3 .

The final conversion is accomplished in the fourth catalyst layer and overall conversion rate reaches more than 99.7%. The converted gas goes to the second absorbing tower through the economizer in which excess heat is recovered by heating the boiler feed water.

In the first and second absorbing tower, SO_3 is absorbed into circulating 98.5% sulfuric acid. On the contrary, atmospheric air for the process use is dried in the drying tower by scrubbing with 94% sulfuric acid.

All the circulating acid is cooled by the acid coolers. The product acid is delivered from the circulating line of second absorbing tower, and after cooled by the product cooler, sent to the acid storage tanks.

Double absorption process provides conversion efficiency of 99.5% of sulfur to sulfuric acid, thus SO_2 loss is lower under normal operating condition. The by-product steam is effectively utilized at the triple super phosphate plant.

The specification of phosphate rock is shown in Table AV-5-1.

Table AV-5-1 ANALYSIS OF PHOSPHATE ROCK EXTRACTED FROM IRON ORE CONCENTRATION
NON-MAGNETIC TAILS OF HIPASAM, SIERRA GRANDE, ARGENTINE

(1) CHEMICAL ANALYSIS

As Element	Weight Percent	As Oxide	Weight Percent	Equivalency for 100g Sample
P	15.56%	P ₂ O ₅	35.65%	(-) 1.507
C (Carbonate)	0.09	CO ₂	0.33	(-) 0.015
F	1.50	F	1.50	(-) 0.079
Cl	0.01	Cl	0.01	(-) 0.0005
OH	-	OH	(3.88)	(-) (0.2285)
S (Total)	-	S and Oxides	-	(-) -
S (Sulfide)	0.48	S	0.48	(-) 0.030
S (Sulfate)	-	SO ₃	-	(-) -
Si	1.98	SiO ₂	4.24	(-) 0.141
Fe (Total)	5.80	Fe Oxides	7.57	(+) 0.233
Fe (II)	4.36	FeO	(5.61)	(+) (0.156)
Fe (III)	1.44	Fe ₂ O ₃	(2.06)	(+) (0.077)
Al	1.46	Al ₂ O ₃	2.06	(+) 0.162
Mn	-	MnO	-	(+) -
Ca	31.66	CaO	44.30	(+) 1.580
Mg	0.22	MgO	0.36	(+) 0.018
Na	0.15	Na ₂ O	0.20	(+) 0.006
K	0.07	K ₂ O	0.08	(+) 0.002
Others	-	Others	-	-
Free Moisture	0.14	Free Moisture	0.14	-
Organics	-	Organics	-	-
Ignition Loss	1.68	Ignition Loss	1.68	-
Total	65.95	Sub-total	102.58	(-) 2.001
		Adjustment for F	(-) 0.63	(+) 2.001
		Total	101.95	(+) 0.000

(2) PHYSICAL PROPERTY

Color	Gray
Size Distribution (Tyler Mesh and Millimeter)	
(+) 400 Mesh (0.0370 mm)	15.9%
(+) 468.4 (0.0316)	18.4
(+) 677.8 (0.0219)	36.1
(+) 993.3 (0.0149)	52.5
(+) 1,309.7 (0.0113)	64.5
(-) 1,309.7 (0.0113)	35.4
	100.0
Density	3.27
Bulk Density - Packed	1.67
- Loose	1.27
Angle of Reponse	43.0°
Free Moisture of Filter Cake, %	13.0
Specific Surface Area, cm ² /gr	2,770

(3) FERTILIZER PROPERTY

	Weight Percent	Solubility Percent
Total P ₂ O ₅	35.65%	100.0%
Nitric Acid Soluble P ₂ O ₅	35.60	99.9
Hydrochloric Acid Soluble P ₂ O ₅	35.11	98.5
Citric Acid Soluble P ₂ O ₅	7.96	22.3
Formic Acid Soluble P ₂ O ₅	5.69	16.0
Ammonium Citrate Soluble (AV) P ₂ O ₅ (Neutral)	0.00	0.0
Water Soluble P ₂ O ₅	0.00	0.0

Notes: - Sample tails (Fe=27.53%, P₂O₅=7.08%) were taken on October 6, 1983 at HIPASAM and concentration test and analysis were made at NIKKO Consulting and Engineering Co. Ltd., Japan in January, 1984. Recovery of P₂O₅ is 55.5%. Fertilizer property was determined at Nissan Chemical Industries, Ltd., Japan in March, 1984.
- Ignition loss is measured by heating at 900°C for 0.5 hours.
- Free moisture is measured by heating at 105°C for 5.0 hours.
- (OH) is estimated to keep balanced equivalency.

(3) Product Specification

The process plant is to produce 191.5 TPD (as 100% H_2SO_4) of sulfuric acid in bulk under normal operating conditions.

The specification of the product is as follows;

Sulfuric Acid;

-Daily Production (as H_2SO_4)	191.5 TPD
-Analysis	
- H_2SO_4	98.0 %
-Moisture	2.0
-Conditions	
-Temperature	40.0°C
-Pressure	1.0 ata

(4) Raw Material, Utility, Chemicals and Catalyst Consumption

The consumption of raw material for the production of sulfuric acid under normal operating conditions is as follows:

	<u>Production and Consumption</u>		
	<u>Unit Product</u>	<u>Hourly</u>	<u>Daily</u>
Production;			
-Sulfuric Acid, Ton	1.000	7.979	191.5
Consumption;			
-Sulfur, Ton	0.331	2.61	62.6
-Cooling Water, Ton	45.50	363.04	8,712.9
-Boiler Feed Water, Ton	1.35	10.77	258.5
-Electric Power, kWh	62.50	498.69	11,968.6
-Steam (30 atg, Export), Ton	1.25	9.97	239.3
-Catalyst, liter*	0.0175	0.14	3.4

* The consumption of catalysts and chemicals are equivalent to USD 0.25 (CIF)/Ton of sulfuric acid on the date of base project cost estimate.

2-2 Phosphoric Acid Plant

(1) Introduction

Phosphoric acid is an intermediate for the production of triple super phosphate and is produced by the reaction of phosphate rock and sulfuric acid.

The production capacity of the process plant is 81.9 TPD of P_2O_5 and its concentration is 40.0% as P_2O_5 in the phosphoric acid product. The filter acid before concentration is containing 30.0% P_2O_5 and 5.0% H_2SO_4 . The concentration of H_2SO_4 in the filter acid has to be considerably higher for the treatment of specific phosphate rock to achieve high recovery of P_2O_5 .

The crystalline form of calcium sulfate in phosphoric acid production is, at first, hemihydrate and then converted into dihydrate before filtration. Filter acid is concentrated by vacuum evaporation to 40.0% concentration of P_2O_5 .

The stoichiometric reaction of phosphoric acid production is as follows:

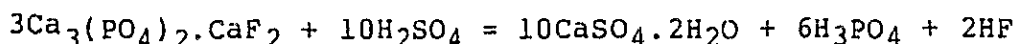

The phosphoric acid plant consists of four major sections:

- Decomposition Section
- Crystallization Section
- Filtration Section
- Concentration Section
- Effluent Treatment Section

(2) Process Description

Raw material phosphate rock and sulfuric acid is reacted to form calcium sulfate hemihydrate at first in decomposition section and then gypsum is formed after recrystallization and hydration under controlled condition of temperature and acid concentration in crystallization section.

This process produces gypsum that is easily filterable and also attains a high P_2O_5 recovery of 97.5% based on the P_2O_5 present in the feed rock with the remaining P_2O_5 being mostly contained in the gypsum cake.

By this process, gypsum of large and uniform size crystals are formed, which is readily applicable for the manufacture of gypsum wall-board and other gypsum derivatives. For the financial analysis of the project, no credit for gypsum is applied.

(a) Decomposition Section

In the decomposition section, the flow of phosphate rock is controlled by continuous belt weigher to feed into premixer. In the premixer tank, an initial mixing takes place with a mixture of sulfuric acid and dilute phosphoric acid recycled from the filtration section. Decomposition of phosphate rock is carried out in digester tanks, wherein a slurry of phosphoric acid and semistable hemihydrate of calcium sulfate is obtained. Both the premixer and digester tanks are mechanically agitated and mild steel lined with synthetic rubbers is used for the tank structure. The decomposition reaction takes place at 90°C with a residence time of half an hour. The sulfuric acid is fed at 75% H_2SO_4 concentration to the phosphate rock decomposition section.

(b) Crystallization Section

The slurry from the decomposition section overflows into a series of crystallizer tanks. A portion of the processed slurry leaving the last crystallizer is recycled to provide seed crystals. The temperature and other processing conditions are controlled so that calcium dihydrate (gypsum) can be obtained as crystals of proper size and shape.

The crystallizer tanks are agitated mildly by mechanical means. Rubber lined tanks are also used in crystallization section.

The hemihydrate to dihydrate conversion is completed in the crystallizer, where the slurry is normally cooled by evaporator cooler.

The hydration section is operated at a temperature of 60°C and at a solid content of 30% in the slurry.

(c) Filtration

The slurry from the last crystallizer is pumped to a continuous vacuum filter, where in the first section the strong acid (30% P_2O_5) is separated from gypsum and sent to storage. The gypsum cake is given two countercurrent washes, firstly with dilute phosphoric acid and further with hot water, the filtrate of the second wash is used as wash liquor used in the first wash section. The filtrate from the first washing, called the return acid, is stored and then used as mixture with sulfuric acid in the premixer of the decomposition section.

The tilting pan filter is used with respect to efficiency and maintenance.

The by-product gypsum is discharged as moist cake to the disposal pond. The thickness of gypsum cake is 5.9 cm and (-)0.59 ata filter vacuum is applied.

(d) Concentration

The product phosphoric acid is containing 30% of P_2O_5 or 41.4% in terms of H_3PO_4 .

This filter acid is further concentrated at vacuum evaporation vessel at a temperature of $90^\circ C$ and under a pressure of (-) 0.855 ata to obtain concentrated acid product which contains 40.0% of P_2O_5 . Further concentration above 40.0% will face technical difficulties because the impurities from the phosphate rock make the product too viscous to handle. The heat needed for the phosphoric acid concentration is supplied by steam which is produced in sulfuric acid plant.

(e) Effluent Treatment Disposal

The effluent gases from the premixer, digesters and concentration section are drawn by a fan through a scrubbing system to remove fluorine compounds.

The off-gas from the crystallization section contains only little fluorine compounds, and therefore the use of a mist eliminator in conjunction with a fan is usually adequate for the gas to be discharge to the atmosphere.

(3) Product Specification

The process plant is to produce a 81.9 TPD of phosphoric acid in terms of P_2O_5 .

The specification of product is as follows:

Phosphoric Acid;

-Daily Production P_2O_5		81.9 TPD
-Analysis;		
-Total P_2O_5		40.00%
- H_2SO_4		6.70
- Fe_2O_3		8.70
- Al_2O_3		2.70
-MgO		0.42
- Na_2O		0.12
- K_2O		0.02
-F		0.95
-Free Moisture		26.80
-Condition;		
-Temperature		75.0°C
-Pressure		1.0 ata
-Specific Gravity	25°C	1.80
	50	1.78
	75	1.76
-Viscosity	25°C	481.0 CP
	50	149.0
	75	63.0
-Color		Brown
-Sludge* (Settling for 24 hours)		1.10%
-Analysis of Sludge		
- P_2O_5		22.78%
- SO_3		25.83
- Fe_2O_3		37.1
-Color		Gray

* It is considered that major chemicals of sludge is complex salt of ferrous phosphate and ferrous sulfate. The above analysis is expressed in terms of ferric oxide but major portion of iron is found in ferrous state in phosphoric acid and in sludge.

(4) Raw Material, Utility, Chemicals and Catalyst Consumption

The consumption of raw material and utility for the production of concentrated phosphoric acid under normal operation condition is as follows:

	<u>Production and Consumption</u>		
	<u>Unit Product</u>	<u>Hourly</u>	<u>Daily</u>
Production;			
-Concentrated Phosphoric Acid, P ₂ O ₅ , Ton	1.000	3.41	81.9
-By-Product Gypsum, Dry Basis, Ton	4.000	13.65	327.6
Consumption;			
-Phosphate Rock, (P ₂ O ₅ : 35.65%), Ton	2.891	9.86	236.8
-Sulfuric Acid (H ₂ SO ₄), Ton	2.341	7.98	191.5
-Electric Power, kWh	105.50	359.76	8,634.2
-Process Water, Ton	5.50	18.76	450.5
-Cooling Water, Ton	30.50	104.00	2,497.9
-Steam, Ton	1.38	4.71	113.0

2-3 Triple Super Phosphate Plant

(1) Introduction

Granular triple super phosphate (TSP) is produced by the reaction of phosphate rock and phosphoric acid.

The production capacity of the process plant is 243.3 TPD of TSP.

(2) Process Description

The stoichiometric reaction of triple super phosphate production is as follows:

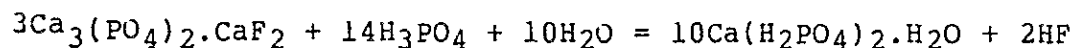

Phosphate rock is reacted with preheated phosphoric acid with 40% P_2O_5 concentration in a series of steam heated and stirred reaction vessels at a temperature of 90°C for 30 minutes. The reaction slurry is then fed to a blunger granulator together with a high portion of recycle fines. The moist granulated triple super phosphate is dried in rotary drum dryer where hot air produced by steam heating is co-currently supplied. The dried product is screened and the product sized materials are cooled, and then sent to the storage. The crushed over sized product and under sized product are recycled back to the blunger granulator for further processing.

(3) Product Specification

The process plant is to produce a 243.3 TPD of granular triple superphosphate in bulk under normal operating conditions.

The specification of such products are as follows:

Granular Triple Super Phosphate;

-Daily Production	243.3 TPD
-Analysis	
-Total P ₂ O ₅	47.33%
-Available P ₂ O ₅	35.30
-Water Soluble P ₂ O ₅	31.00
-Free Acid as P ₂ O ₅	7.0
-Free Moisture	2.0
-Condition	
-Temperature	40°C
-Pressure	1.0 ata
-Size Distribution	
(-) 4.0, (+) 1.0 mm	95.0 %
-Bulk Density	1.0
-Angel of Repose	32.0°
-Crushing Strength (3.0 mm)	1.5 kg

(4) Raw Material, Utility, Chemicals and Catalyst Consumption

	<u>Production and Consumption</u>		
	<u>Unit Product</u>	<u>Hourly</u>	<u>Daily</u>
Production;			
-Granular Triple Super Phosphate, Bulk, Ton	1.000	10.138	243.3
Consumption;			
-Phosphate Rock, (P ₂ O ₅ 33.65%), Ton	0.3966	4.02	96.5
-Phosphoric Acid, P ₂ O ₅ , Ton	0.3366	3.41	81.9
-Electric Power, kWh	62.5	633.63	15,206.2
-Process Water, Ton	0.350	3.55	85.1
-Steam, Ton	0.375	3.80	91.2

2-2 Utility Plants

The major utility plants required for the triple super phosphate fertilizer plant are as follows;

	<u>Facility Capacity</u>	<u>Normal Demand</u>
Electric Power Receiving, kWh/h	2,000	1,417
Natural Gas Receiving, MMSCFD	5	-
Raw Water Treatment, TPD	2,000	1,550
Waste Water Treatment, TPD	1,000	-
Steam Generation, TPH	5.0	-
Cooling Water Tower, TPH	600	500

2-5 Storage and Material Handling Facility

The major facility for raw materials, intermediates, and product receiving, storage, bagging and other material handlings are designed to have following capacities;

	<u>Facility Capacity</u>	<u>Normal Demand</u>
Storage Facilities;		
-Phosphate Rock, Ton	10,000	336.7 TPD
-Sulfur, Ton	2,000	63.3
-Sulfuric Acid, Ton	1,000	191.5
-Product, Bulk, Ton	25,000	243.3
, Bagged, Ton	1,200	243.3
Bagging and Loading Facility;		
-Product, TPH	65	10.1

2-6 Auxiliary Facilities

The major auxiliary facilities for the management of the production, maintenance and accommodation at the triple super phosphate fertilizer plant is designed to have following specifications;

Facility Specification

Administration Building	1,000 m ₂
Laboratory	300
Canteen	400
Garage and Gate House	100
Maintenance Shop	1,200
Storage House	1,200
Fire Fighting House	200
Others	-

3. Project Summary

3-1 Product and Production

The proposed triple super phosphate fertilizer plant project is to produce granular triple super phosphate fertilizer in bagged form from phosphate rock and sulfur as major inputs.

The brief specification of the product and production is summarized as follows:

<u>Product</u>	<u>Fertilizer Specification, %</u>				<u>Production, Ton</u>	
		<u>T-</u>	<u>W-</u>	<u>W-</u>	<u>Daily</u>	<u>Annual</u>
	<u>T-N</u>	<u>P₂O₅</u>	<u>P₂O₅</u>	<u>K₂O</u>		
Granular Triple Super Phosphate, Bagged	0.0	47.33	31.00	0.0	243.3	72,260

The limiting factor for the production is the availability of phosphate rock which is recovered from the non-magnetic tails of HIPASAM, Sierra Grande, Río Negro. The total available phosphate rock is 100,000 TPY and the loss for transportation and handling of 2.0% is reduced from the production calculation.

3-2 Overall Consumption

The overall consumption of raw material, utility, catalysts and chemicals for the proposed project is calculated for the financial analysis of the project which includes losses during storage, processing and bagging of the products, and also consumption for utility and auxiliary facilities.

	Production and Consumption		
	<u>Unit Product</u>	<u>Hourly</u>	<u>Daily</u>

Production;

-Granular Triple Super Phosphate, Bagged, Ton	1.000	10.138	243.3
---	-------	--------	-------

Consumption;

-Phosphate Rock,, Ton	1.3839	14.03	336.7
-Sulfur, Ton	0.2602	2.64	63.3
-Electric Power, kWh	139.7	1,416.7	37,000.0
-Raw Water, Ton	6.37	64.58	1,550.0
-Fertilizer Bag, 50kg Net, Sheet	20.20	204.78	4,914.7
-Catalysts and Chemicals, USD	0.271	2.73	65.5

3-3 Overall Flow Block Diagram

The overall flow block diagram of the triple super phosphate plant showing process plant, utility and auxiliary facilities are illustrated in Figure AV-5-1.

Raw Material and Utility Input

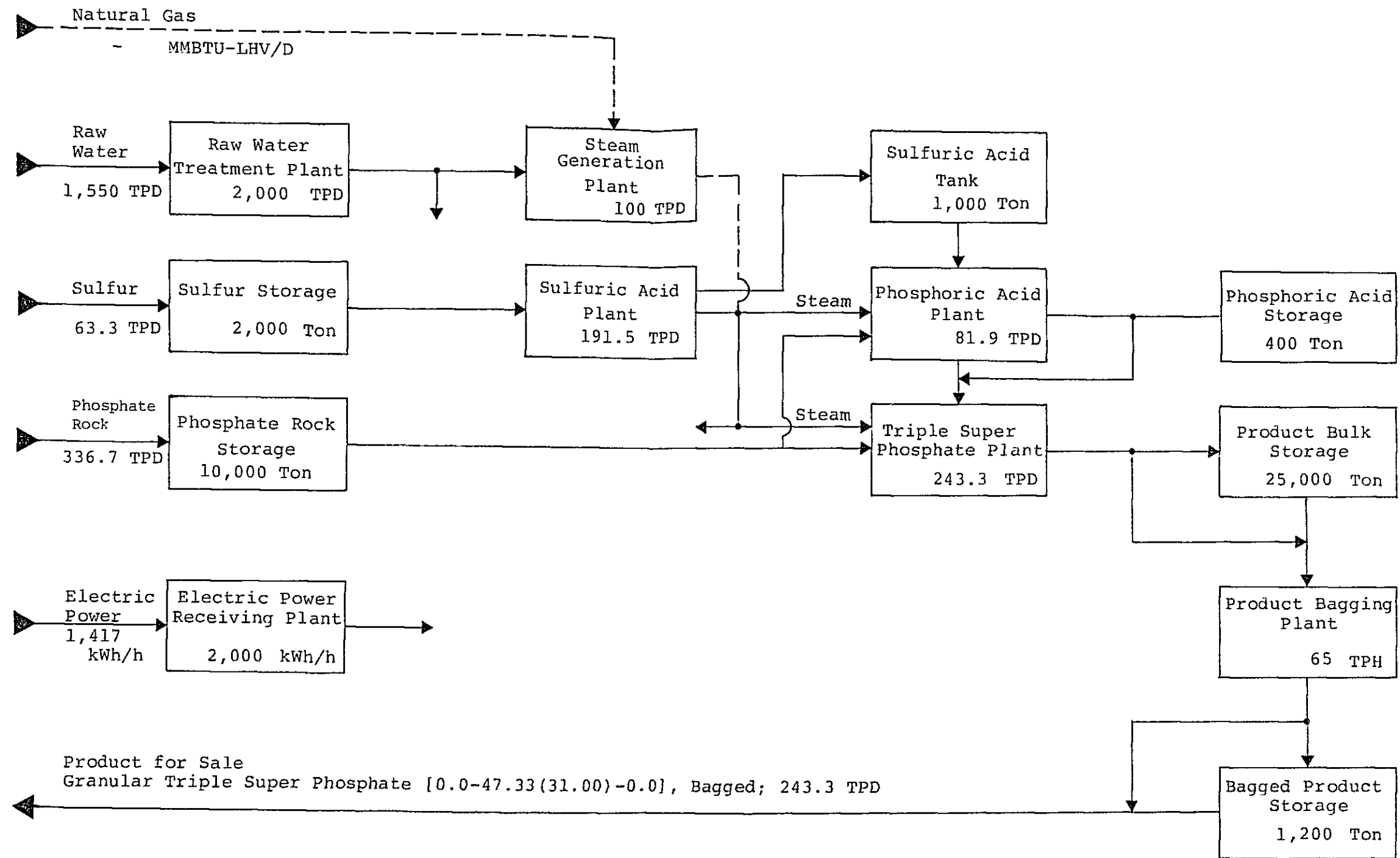

Figure AV-5-1

BLOCK FLOW DIAGRAM FOR PHOSPHATE FERTILIZER PLANT
 Project: Granular Triple Super Phosphate Fertilizer Plant ... PF-4
 Feasibility Study: The Establishment of a Phosphate Fertilizer
 Plant in the Argentine Republic. Japan
 International Cooperation Agency. April, 1984

Annex V-6

PROJECT DESCRIPTION FOR PHOSPHATE FERTILIZER PLANT

PF - 5 . . . MAP/DAP

Monoammonium Phosphate/Diammonium Phosphate Production

PROJECT DESCRIPTION FOR PHOSPHATE FERTILIZER PLANT
PF - 5 ... MAP/DAP

Monoammonium Phosphate/Diammonium Phosphate Production

1. Project Outline

The proposed phosphate fertilizer plant project is to produce 243.8 TPD of granular monoammonium phosphate (MAP) fertilizer [10.2-45.91 (Av-P₂O₅)-0.0] or 262.1 TPD of granular diammonium phosphate (DAP) fertilizer [15.24-42.70 (Av-P₂O₅)-0.0] from the raw materials of phosphate rock, imported liquid ammonia and imported sulfur. Since the plant can versatily produce MAP and DAP only by changing slightly the operational conditions, and the quality of both products, as far as produced based on identical source of phosphate rock, is similar and analogous, the following description represented by that of MAP.

The raw materials phosphate rock will be recovered at the phosphate rock concentration plant of non-magnetic tails of HIPASAM, Sierra Grande, Argentine and sulfur will be imported from USA, Canada or Mexico because there is no available sulfur source identified in Argentine at present. Liquid ammonia is also imported because no surplus liquid ammonia is available in domestic market.

Monoammonium phosphate (MAP) is a weak acidic and high analysis phosphate fertilizer but due to the high impurities in the product, mostly iron chemicals which derived from the phosphate rock, the fertilizer analysis is a little lower than conventional product which grade is generally from (11.0-53.0-0.0) to (12.0-51.0-0.0). The

solubility of P_2O_5 in the product dissolved in water and ammonium citrate solution is also lower, especially water soluble P_2O_5 to total P_2O_5 in the product is only 65.0% which is lower than the figures of 93.0% to 83.0% for conventional product. The low solubility of P_2O_5 is mostly due to the high iron phosphate impurity delivered from the phosphate rock.

The fertilizer standards in Argentine designates the effectiveness of P_2O_5 in MAP should be measured by available phosphate and its minimum requirement is specified as (11.4-48.0-0.0).

The optimum operating conditions, product quality and its process consumption were found by the small scale tests (0.20kg/Batch) at Nissan Chemical Industries, Ltd, Japan by using recovered phosphate rock from the non-magnetic tails of HIPASAM, Sierra Grande, Argentine. The experimental test results are incorporated in the conceptual design of the product.

The design capacity of the plant is to produce 243.8 TPD of MAP (262.1 TPD in terms of DAP) and its annual production in 297 days is 72,409 TPY (77,840 TPY in terms of DAP).

The major facility in the plant is as follows:

Process Plant;

-Sulfuric Acid	269.7 TPD
-Phosphoric Acid	115.3
-Monoammonium Phosphate	243.8
(Diammonium Phosphate)	(262.1)

Utility Plant;

-Electric Power Receiving	2,000 kWh/h
-Natural Gas Receiving	5 MMSCFD
-Raw Water Treatment	3,000 TPD
-Cooling Water Tower	19,200
-Waste Water Treatment	3,000 TPD
-Steam Generation	5 TPH

Storage and Material Handling Facility;

-Liquid Ammonia	2,000 Ton
-Phosphate Rock	10,000
-Sulfur	3,000
-Sulfuric Acid	14,000
-Phosphoric Acid, P ₂ O ₅	600
-Product	26,200
-Product Bagging	65 TPH

Auxiliary Facility;

-Administration Building	1,000 m ²
-Maintenance Shop and Storage	2,400
-Others	

The total area for the project site is 97,500 m² (300m x 325m).

2. Plant Description

The outline of the process plant, utility plant, storage and material handling facility for the production of monoammonium phosphate (MAP)/diammonium phosphate (DAP) are described hereafter.

2-1 Sulfuric Acid Plant

(1) Introduction

The sulfuric acid is produced by catalytic oxidation of sulfur dioxide gas which is produced by combustion of sulfur. The sulfur trioxide gas is absorbed in weak sulfuric acid to produce concentrated sulfuric acid.

The production capacity of the process plant is 269.7 TPD as 100% H₂SO₄ which is captively consumed for the production of monoammonium phosphate/diammonium phosphate fertilizer at the plant. The raw material sulfur is imported.

(2) Process Description

The stoichiometric reaction for the production of sulfuric acid is;

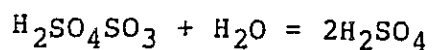
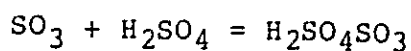
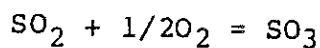
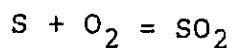

Raw material solid sulfur is melted and purified in the sulfur pit where steam heating is applied to produce molten sulfur which is pumped up to the sulfur furnace.

The pumped sulfur is sprayed through atomizing nozzles of the burner guns. The combustion air is supplied to make vigorous vortex for complete burning of sulfur.

Approximately 10 vol% of SO_2 gas is generated at the sulfur furnace and gas cooling is accomplished in the waste heat boiler before fed to the converter.

The converter consists of four catalyst layers. The first three layers are primary conversion and the last one is for secondary conversion stage. Each conversion stage is followed by primary and secondary absorption steps, respectively.

The reaction heat at the first catalyst layer is removed in the first heat exchanger for cooling down its temperature for reaction at second layer.

The reaction heat at the second layer is removed in the superheater by which saturated steam from the waste heat boiler is superheated (30 atg) for steam production.

The reaction heat at the third catalyst layer is also removed in the second and third heat exchangers for absorbing SO_3 efficiently in the first absorbing tower.

The gas from the first absorbing tower is led to the secondary conversion stage, via the second and third heat exchangers to raise its temperature for further conversion of SO_2 to SO_3 .

The final conversion is accomplished in the fourth catalyst layer and overall conversion rate reaches more than 99.7%. The converted gas goes to the second absorbing tower through the economizer in which excess heat is recovered by heating the boiler feed water.

In the first and second absorbing tower, SO_3 is absorbed into circulating 98.5% sulfuric acid. On the contrary, atmospheric air for the process use is dried in the drying tower by scrubbing with 94% sulfuric acid.

All the circulating acid is cooled by the acid coolers. The product acid is delivered from the circulating line of second absorbing tower, and after cooled by the product cooler, sent to the acid storage tanks.

Double absorption process provides conversion efficiency of 99.5% of sulfur to sulfuric acid, thus SO_2 loss is lower under normal operating condition. The by-product steam is effectively utilized at the triple super phosphate plant.

The specification of phosphate rock is shown in Table AV-6-1.

Table AV-6-1 ANALYSIS OF PHOSPHATE ROCK EXTRACTED FROM IRON ORE CONCENTRATION
NON-MAGNETIC TAILS OF HIPASAM, SIERRA GRANDE, ARGENTINE

(1) CHEMICAL ANALYSIS

<u>As Element</u>	<u>Weight Percent</u>	<u>As Oxide</u>	<u>Weight Percent</u>	<u>Equivalency for 100g Sample</u>
P	15.56%	P ₂ O ₅	35.65%	(-) 1.507
C (Carbonate)	0.09	CO ₂	0.33	(-) 0.015
F	1.50	F	1.50	(-) 0.079
Cl	0.01	Cl	0.01	(-) 0.0005
OH	-	OH	(3.88)	(-) (0.2285)
S (Total)	-	S and Oxides	-	(-) -
S (Sulfide)	0.48	S	0.48	(-) 0.030
S (Sulfate)	-	SO ₃	-	(-) -
Si	1.98	SiO ₂	4.24	(-) 0.141
Fe (Total)	5.80	Fe Oxides	7.67	(+) 0.233
Fe (II)	4.36	FeO	(5.61)	(+) (0.156)
Fe (III)	1.44	Fe ₂ O ₃	(2.06)	(+) (0.077)
Al	1.46	Al ₂ O ₃	2.06	(+) 0.162
Mn	-	MnO	-	(+) -
Ca	31.66	CaO	44.30	(+) 1.580
Mg	0.22	MgO	0.36	(+) 0.018
Na	0.15	Na ₂ O	0.20	(+) 0.006
K	0.07	K ₂ O	0.08	(+) 0.002
Others	-	Others	-	-
Free Moisture	0.14	Free Moisture	0.14	-
Organics	-	Organics	-	-
<u>Ignition Loss</u>	<u>1.68</u>	<u>Ignition Loss</u>	<u>1.68</u>	
Total	65.95	Sub-total	102.58	(-) 2.001
		Adjustment for F	(-) 0.63	(+) 2.001
		Total	101.95	(+) 0.000

(2) PHYSICAL PROPERTY

Color	Gray
Size Distribution (Tyler Mesh and Millimeter)	
(+) 400 Mesh (0.0370 mm)	15.9%
(+) 468.4 (0.0316)	18.4
(+) 677.8 (0.0219)	36.1
(+) 993.3 (0.0149)	52.5
(+) 1,309.7 (0.0113)	64.5
(-) 1,309.7 (0.0113)	35.4
	100.0
Density	3.27
Bulk Density - Packed	1.67
- Loose	1.27
Angle of Reponse	43.0°
Free Moisture of Filter Cake, %	13.0
Specific Surface Area, cm ² /gr	2,770

(3) FERTILIZER PROPERTY

	<u>Weight Percent</u>	<u>Solubility Percent</u>
Total P ₂ O ₅	35.65%	100.0%
Nitric Acid Soluble P ₂ O ₅	35.60	99.9
Hydrochloric Acid Soluble P ₂ O ₅	35.11	98.5
Citric Acid Soluble P ₂ O ₅	7.96	22.3
Formic Acid Soluble P ₂ O ₅	5.69	16.0
Ammonium Citrate Soluble (AV) P ₂ O ₅ (Neutral)	0.00	0.0
Water Soluble P ₂ O ₅	0.00	0.0

Notes: - Sample tails (Fe=27.53%, P₂O₅=7.08%) were taken on October 6, 1983 at HIPASAM and concentration test and analysis were made at NIKKO Consulting and Engineering Co. Ltd., Japan in January, 1984. Recovery of P₂O₅ is 55.5%. Fertilizer property was determined at Nissan Chemical Industries, Ltd., Japan in March, 1984.

- Ignition loss is measured by heating at 900°C for 0.5 hours.
- Free moisture is measured by heating at 105°C for 5.0 hours.
- (OH) is estimated to keep balanced equivalency.

(3) Product Specification

The process plant is to produce 269.7 TPD (as 100% H_2SO_4) of sulfuric acid in bulk under normal operating conditions.

The specification of the product is as follows;

Sulfuric Acid;

-Daily Production (as H_2SO_4)	269.7 TPD
-Analysis	
- H_2SO_4	98.0 %
-Moisture	2.0
-Conditions	
-Temperature	40.0°C
-Pressure	1.0 ata

(4) Raw Material, Utility, Chemicals and Catalyst Consumption

The consumption of raw material for the production of sulfuric acid under normal operating conditions is as follows:

	<u>Production and Consumption</u>		
	<u>Unit Product</u>	<u>Hourly</u>	<u>Daily</u>
Production;			
-Sulfuric Acid, Ton	1.000	11.238	269.7
Consumption;			
-Sulfur, Ton	0.331	3.72	89.3
-Cooling Water, Ton	45.50	511.31	12,271.4
-Boiler Feed Water, Ton	1.35	15.17	364.1
-Electric Power, kWh	62.50	702.34	16,856.2
-Steam (30 atg, Export), Ton	1.25	14.05	337.2
-Catalyst, liter*	0.0175	0.20	4.8

* The consumption of catalysts and chemicals are equivalent to USD 0.25 (CIF)/Ton of sulfuric acid on the date of base project cost estimate.

2-2 Phosphoric Acid Plant

(1) Introduction

Phosphoric acid is an intermediate for the production of monoammonium phosphate and is produced by the reaction of phosphate rock and sulfuric acid.

The production capacity of the process plant is 115.3 TPD of P_2O_5 and its concentration is 40.0% as P_2O_5 in the phosphoric acid product. The filter acid before concentration is containing 30.0% P_2O_5 and 5.0% H_2SO_4 . The concentration of H_2SO_4 in the filter acid should be considerably higher for the treatment of specific phosphate rock to achieve high recovery of P_2O_5 .

The crystalline form of calcium sulfate at phosphoric acid production is, at first hemihydrate and then converted into dihydrate before filtration. Filter acid is concentrated by vacuum evaporation to 40.0% concentration of P_2O_5 .

The stoichiometric reaction of phosphoric acid production is as follows:

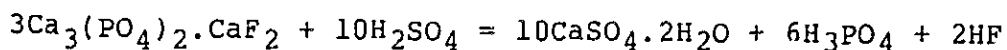

The phosphoric acid plant consists of four major sections:

- Decomposition Section
- Crystallization Section
- Filtration Section
- Concentration Section
- Effluent Treatment Section

(2) Process Description

Raw material phosphate rock and sulfuric acid is reacted to form calcium sulfate hemihydrate at first in decomposition section and then gypsum is formed after recrystallization and hydration under controlled condition of temperature and acid concentration in crystallization section.

This process produces gypsum that is easily filterable and also attains a high P_2O_5 recovery of 97.5% based on the P_2O_5 present in the feed rock with the remaining P_2O_5 being mostly contained in the gypsum cake.

By this process, gypsum of large and uniform size crystals are formed, which is readily applicable for the manufacture of gypsum wall-board and other gypsum derivatives. For the financial analysis of the project, no credit for gypsum is applied.

(a) Decomposition Section

In the decomposition section, the flow of phosphate rock is controlled by continuous belt weigher to feed into premixer. In the premixer tank, an initial mixing takes place with a mixture of sulfuric acid and dilute phosphoric acid recycled from the filtration section. Decomposition of phosphate rock is carried out in digester tanks, wherein a slurry of phosphoric acid and semistable hemihydrate of calcium sulfate is obtained. Both the premixer and digester tanks are mechanically agitated and mild steel lined with synthetic rubbers is used for the tank structure. The decomposition reaction takes place at 90°C with a residence time of half an hour. The sulfuric acid is fed at 75% H_2SO_4 concentration to the phosphate rock decomposition section.

(b) Crystallization Section

The slurry from the decomposition section overflows into a series of crystallizer tanks. A portion of the processed slurry leaving the last crystallizer is recycled to provide seed crystals. The temperature and other processing conditions are controlled so that calcium dihydrate (gypsum) can be obtained as crystals of proper size and shape.

The crystallizer tanks are agitated mildly by mechanical means. Rubber lined tanks are also used in crystallization section.

The hemihydrate to dihydrate conversion is completed in the crystallizer, where the slurry is normally cooled by evaporator cooler.

The hydration section is operated at a temperature of 60°C and at a solid content of 30% in the slurry.

(c) Filtration

The slurry from the last crystallizer is pumped to a continuous vacuum filter, where in the first section the strong acid (30% P_2O_5) is separated from gypsum and sent to storage. The gypsum cake is given two countercurrent washes, firstly with dilute phosphoric acid and further with hot water, the filtrate of the second wash is used as wash liquor used in the first wash section. The filtrate from the first washing, called the return acid, is stored and then used as mixture with sulfuric acid in the premixer of the decomposition section.

The tilting pan filter is used with respect to efficiency and maintenance.

The by-product gypsum is discharged as moist cake to the disposal pound. The thickness of gypsum cake is 5.9 cm and (-)0.59 ata filter vacuum is applied.

(d) Concentration

The product phosphoric acid is containing 30% of P_2O_5 or 41.4% in terms of H_3PO_4 .

This filter acid is further concentrated at vacuum evaporation vessel at a temperature of 90°C and under a pressure of (-) 0.855 ata to obtain concentrated acid product which contains 40.0% of P_2O_5 . Further concentration above 40.0% will face technical difficulties because the impurities from the phosphate rock make the product too viscous to handle. The heat needed for the phosphoric acid concentration is supplied by steam which is produced in sulfuric acid plant.

(e) Effluent Treatment Disposal

The effluent gases from the premixer, digesters and concentration section are drawn by a fan through a scrubbing system to remove fluorine compounds.

The off-gas from the crystallization section contains only little fluorine compounds, and therefore the use of a mist eliminator in conjunction with a fan is usually adequate for the gas to be discharge to the atmosphere.

(3) Product Specification

The process plant is to produce a 81.9 TPD of phosphoric acid in terms of P_2O_5 .

The specification of product is as follows:

Phosphoric Acid;		
-Daily Production P_2O_5		115.3 TPD
-Analysis;		
-Total P_2O_5		40.00%
- H_2SO_4		6.70
- Fe_2O_3		8.70
- Al_2O_3		2.70
-MgO		0.42
- Na_2O		0.12
- K_2O		0.02
-F		0.95
-Free Moisture		26.80
-Condition;		
-Temperature		75.0°C
-Pressure		1.0 ata
-Specific Gravity	25°C	1.80
	50	1.78
	75	1.76
-Viscosity	25°C	481.0 CP
	50	149.0
	75	63.0
-Color		Brown
-Sludge* (Settling for 24 hours)		
-Analysis of Sludge		
- P_2O_5		22.78%
- SO_3		25.83
- Fe_2O_3		37.1
-Color		Gray

* It is considered that major chemicals of sludge is complex salt of ferrous phosphate and ferrous sulfate. The above analysis is expressed in terms of ferric oxide but major portion of iron is found in ferrous state in phosphoric acid and in sludge.

(4) Raw Material, Utility, Chemicals and Catalyst Consumption

The consumption of raw material and utility for the production of concentrated phosphoric acid under normal operation condition is as follows:

	Production and Consumption		
	<u>Unit Product</u>	<u>Hourly</u>	<u>Daily</u>
Production;			
-Concentrated Phosphoric Acid, P ₂ O ₅ , Ton	1.000	4.804	115.3
-By-Product Gypsum, Dry Basis, Ton	4.000	19.217	461.2
Consumption;			
-Phosphate Rock, (P ₂ O ₅ : 35.65%), Ton	2.891	13.888	333.3
-Sulfuric Acid (H ₂ SO ₄), Ton	2.341	11.246	269.9
-Electric Power, kWh	105.50	506.82	12,163.7
-Process Water, Ton	5.50	26.42	634.1
-Cooling Water, Ton	30.50	146.52	3,516.5
-Steam, Ton	1.38	6.63	159.12

2-3 Monoammonium Phosphate/Diammonium Phosphate Plant

(1) Introduction

Granular monoammonium phosphate (MAP) fertilizer is produced by the neutralization reaction of phosphoric acid and liquid ammonia. The partially neutralized slurry is granulated in ammoniator-granulator and then dried to produce granular ammonium phosphate. The process plant will be also to produce diammonium phosphate (DAP) if raw material and operation conditions are adjusted according to the market demand. Commercially available MAP fertilizer is a mixture of monoammonium phosphate and diammonium phosphate.

(2) Process Description

The stoichiometric reaction of ammonium phosphates production is as follows:

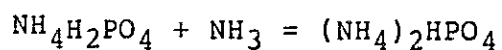
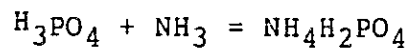

Concentrated phosphoric acid with 40% P_2O_5 concentration is at first fed to a preneutralizer vessel where gaseous ammonia is introduced to form neutralized ammonium phosphate slurry with molar ratio of 0.90 to 0.95.

The slurry is concentrated by the heat of neutralization and then fed to the rotary drum of ammoniator-granulator where the slurry is sprayed on the moving bed of recycle fines and also further ammoniated by feeding liquid ammonia to raise to molar ratio to 1.40.

The most granular monoammonium phosphate is then fed to the rotary dryer where steam heated hot air is fed co-currently. The dried product is screened to obtain product size granular monoammonium phosphate to send to the storage after cooled in rotary drum cooler.

The oversized product is crushed and returned to the ammoniator-granulator with under sized material for further processing.

A portion of the scrubber water circulating at dust and ammonia recovery from off-gases of ammoniator-granulator, preneutralizer and dryer, is returned to the preneutralizer.

(3) Product Specification

The specification of products are as follows:

Monoammonium Phosphate, Bulk;

-Daily Production	243.8 TPD	(262.1)
-Analysis		
-Total Nitrogen	10.20%	(15.24)
-Ammonical Nitrogen	10.20	(15.24)
-Water Soluble Nitrogen	7.76%	(12.96)
-Total - P ₂ O ₅	46.80%	(43.53)
-Available - P ₂ O ₅	45.91	(42.70)
-Water Soluble - P ₂ O ₅	30.42	(28.29)
-Free Moisture	0.9	(0.9)

-Condition	
-Temperature	40°C
-Pressure	1.0 ata
-Size Distribution	
(-) 3.0, (+) 1.0 mm	95.0%
-Bulk Density	1.0
-Angel of Repose	32.0°
-Crushing Strength (2.0 mm)	2.5 kg

Note: Figures in parentheses indicate those estimated for DAP.

(4) Raw Material, Utility, Chemicals and Catalyst Consumption

	<u>Production and Consumption</u>		
	<u>Unit Product</u>	<u>Hourly</u>	<u>Daily</u>
Production;			
-Granular Monoammonium Phosphate, Bulk, Ton	1.000 (1.000)	10.1583	243.8
Consumption;			
-Liquid Ammonia, Ton	0.1266 (0.1907)	1.28	30.9
-Phosphoric Acid, P ₂ O ₅ , Ton	0.4727 (0.4397)	4.801	115.3
-Steam, Ton	0.4425 (0.4116)	4.37	103.6
-Electric Power, kWh	56.50 (52.56)	573.94	13,774.6
-Process Water, Ton	0.35 (0.33)	3.55	85.4
-Cooling Water, Ton	0.50 (0.47)	5.08	121.9

Note: Figures in parentheses indicate those estimated for DAP.

2-4 Utility Plants

The major utility plants required for the monoammonium phosphate/diammonium phosphate plant are as follows;

	<u>Facility Capacity</u>	<u>Normal Demand</u>
Electric Power Receiving, kWh/h	2,000	1,417
Natural Gas Receiving, MMSCFD	5	-
Raw Water Treatment, TPD	3,000	1,799
Waste Water Treatment, TPD	500	-
Steam Generation, TPH	8.3	-
Cooling Water Tower, TPH	800	663

2-5 Storage and Material Handling Facility

The major facility for raw materials, intermediates, and product receiving, storage, bagging and other material handlings are designed to have following capacities;

	<u>Facility Capacity</u>	<u>Normal Demand</u>
Storage Facilities;		
-Phosphate Rock, Ton	10,000	336.7 TPD
-Sulfur, Ton	3,000	90.2
-Sulfuric Acid, Ton	1,400	269.7
-Phosphoric Acid, Ton	600	115.3
-Product, Bulk, Ton	25,000	243.8
, Bagged, Ton	1,200	243.8
Bagging and Loading Facility;		
-Product, TPH	65	10.2

2-6 Auxiliary Facilities

The major auxiliary facilities for the management of the production, maintenance and accomodation at the triple super phosphate fertilizer plant is designed to have following specifications;

	<u>Facility Specification</u>
Administration Building	1,000 m ²
Laboratory	300
Canteen	400
Garage and Gate House	100
Maintenance Shop	1,200
Storage House	1,200
Fire Fighting House	200
Others	-

3. Project Summary

3-1 Product and Production

The proposed granular monoammonium phosphate/diammonium phosphate fertilizer plant project is to produce granular monoammonium phosphate or diammonium phosphate in bagged form from phosphate rock, sulfur and liquid ammonia as major inputs.

The brief specification of the product and production is summarized as follows:

<u>Product</u>	<u>Fertilizer Specification, %</u>				<u>Production, Ton</u>	
		<u>T-</u>	<u>Av-</u>	<u>W-</u>	<u>Daily</u>	<u>Annual</u>
	<u>T-N</u>	<u>P₂O₅</u>	<u>P₂O₅</u>	<u>K₂O</u>		
Granular MAP, Bagged	10.20	46.80	45.91	0.0	243.8	72,409
Granular DAP, Bagged	15.24	43.53	42.70	0.0	262.1	77,840

The limiting factor for the production is the availability of phosphate rock which is recovered from the non-magnetic tails of HIPASAM, Sierra Grande, Río Negro. The total available phosphate rock is 100,000 TPY and the loss for transportation and handling of 2.0% is reduced from the production calculation.

3-2 Overall Consumption

The overall consumption of raw material, utility, catalysts and chemicals for the proposed project is calculated for the financial analysis of the project which includes losses during storage, processing and bagging of the products, and also consumption for utility and auxiliary facilities.

	Production and Consumption		
	Unit Product	Hourly	Daily
Production;			
-Granular Monoammonium Phosphate, Bagged, Ton	1.000 (1.000)	10.1583	243.8
Consumption;			
-Phosphate Rock, Ton	1.3811 (1.2732)	14.03	336.7
-Liquid Ammonia, Ton	0.1279 (0.1907)	1.30	31.2
-Sulfur, Ton	0.3699 (0.3440)	3.76	90.2
-Electric Power, kWh	180.49 (167.90)	1,833.46	44,003.0
-Raw Water, Ton	6.60 (6.87)	67.08	1,609.0
-Fertilizer Bag, 50kg Net, Sheet	20.20 (20.20)	205.20	4,927.7
-Catalysts and Chemicals, USD - 1983	0.3855 (0.347)	3.92	94.0

Note: Figures in parentheses indicate those estimated for DAP.

3-3 Overall Flow Block Diagram

The overall flow block diagram of the monoammonium phosphate/diammonium phosphate plant showing process plant, utility and auxiliary facilities are illustrated in Figure AV-6-1.

3-4 General Plot Plan

The general plot plan of the monoammonium phosphate/diammonium phosphate plant showing location of each major facilities are illustrated in Figure AV-6-2. The total site area required is 135,000 m² (450m x 300m)

3-5 Organization and Personnel

The overall organization and personnel for the monoammonium phosphate/diammonium phosphate plant project is illustrated in Table AV-6-2. The total number of personnel in the organization is 298 under normal operating conditions.

3-6 Investment Cost Estimate

The estimated investment cost for the construction of the monoammonium phosphate/diammonium phosphate plant is illustrated in Table AV-6-3. The project is assumed to be started with engineering works on January 1, 1987 and the commercial production is commenced on January 1, 1990, and located in Bahía Blanca, Buenos Aires, Argentine

3-7 Project Implementation Schedule

The overall implementation schedule for the monoammonium phosphate/diammonium phosphate plant project is illustrated in Figure AV-6-3. It takes 30 months for the mechanical completion and 36 months for the commencement of commercial production from the date of contract award for the plant construction.

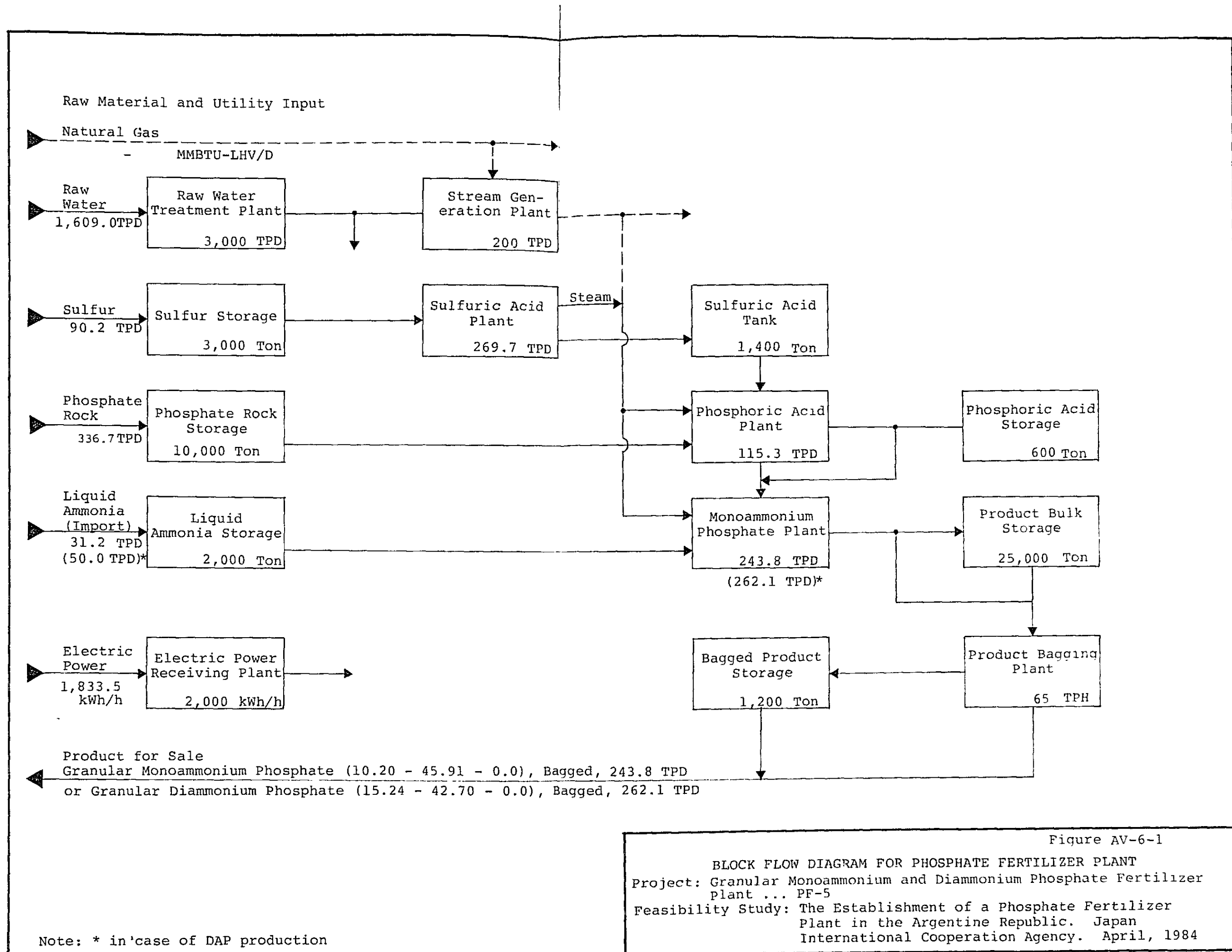

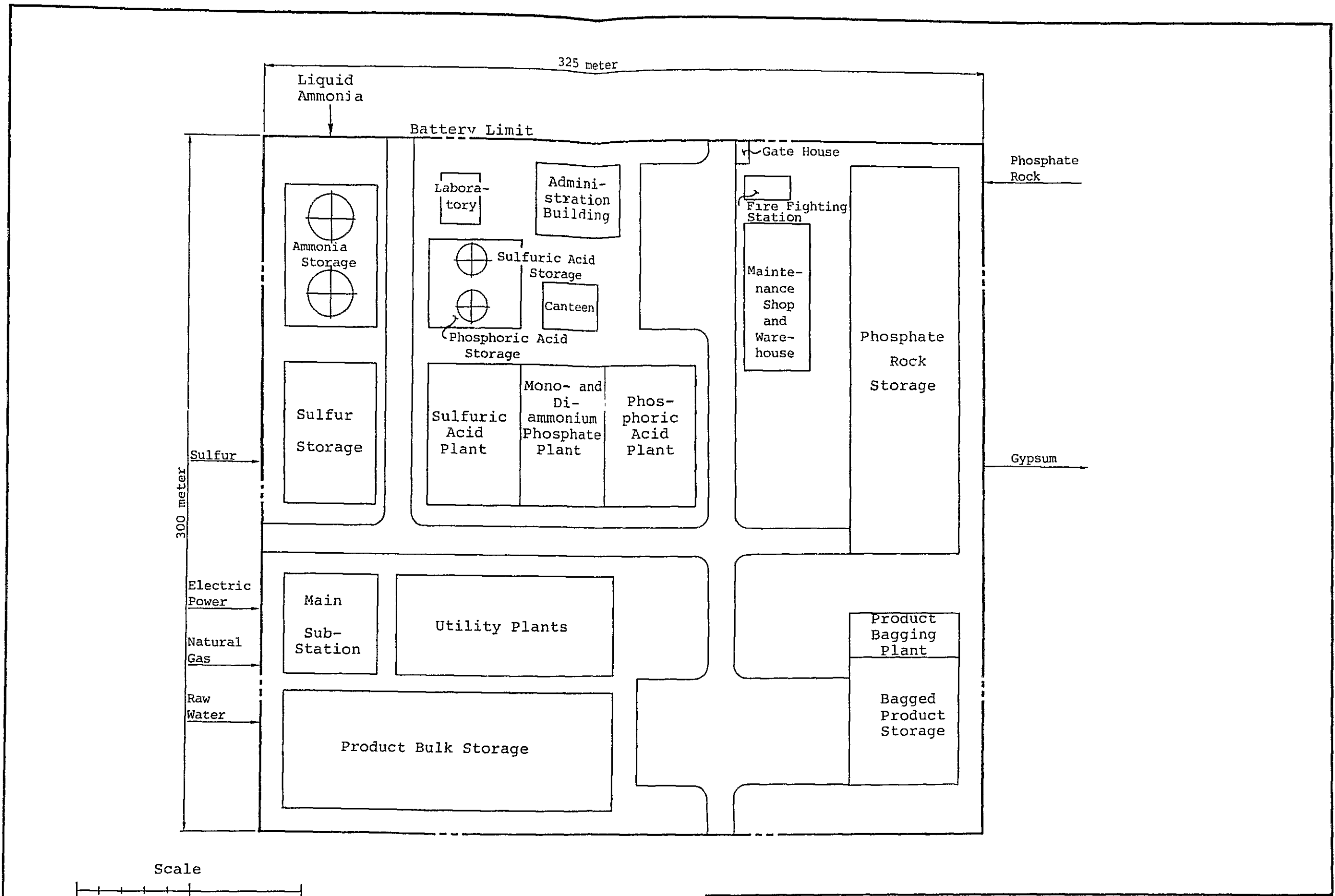

Figure AV-6-2
 GENERAL PLOT PLAN FOR PHOSPHATE FERTILIZER PLANT
 Project: Monoammonium and Diammonium Phosphate Fertilizer
 Plant ... PF-5
 Feasibility Study: The Establishment of a Phosphate Fertilizer
 Plant in the Argentine Republic. Japan
 International Cooperation Agency. April, 1984

Table AV-6-2 ORGANIZATION AND PERSONNEL REQUIREMENTS

Feasibility Study: On the Establishment of a Phosphate Fertilizer Plant in the Argentine Republic
 Project: Phosphate Fertilizer Plant, FC-5
 Product: Monoammonium Phosphate (MAP)/Diammonium Phosphate (DAP), Bagged
 Capacity: 72,409 TPY of MAP (or 77,840 TPY of DAP)
 Location: Bahía Blanca, Buenos Aires, Argentine

Organization for the Project	Managing Director, Director	General Manager, Manager	Senior Engineer and Officer	Supervisor, Foreman, Officer	Operator, Worker, Secretary	Total
1. Head Office and Regional Sales Office - Buenos Aires	(6)	(2)	(3)	(4)	(4)	(19)
2. Factory Head Office and Plant Factory Complex - Bahía Blanca	(1)	(20)	(31)	(73)	(154)	(279)
2.1 Factory Director's Office	(1)	(1)	(2)	(4)	(4)	(12)
2.2 General Affair Department	(0)	(4)	(7)	(7)	(14)	(32)
- Administration Section	0	1	1	1	2	5
- Personnel Section	0	0	1	1	2	4
- Financing/Accounting Section	0	1	1	1	2	5
- Housing and Welfare Section	0	0	1	1	2	4
- Security and Health Section	0	1	1	1	2	5
- Legal Section	0	0	1	1	3	4
- Purchase and Product Sales Section	0	1	1	1	2	4
2.3 Production Department	(0)	(3)	(3)	(15)	(44)	(65)
- Sulfuric Acid	0	1	1	5	12	19
- Phosphate Acid Plant	0	1	1	5	16	23
- Monoammonium Phosphate Plant	0	1	1	5	16	23
2.4 Utility Department	(0)	(3)	(3)	(12)	(24)	(42)
- Water Treatment	0	1	1	4	8	14
- Cooling Water Tower	0	1	1	4	8	14
- Others	0	1	1	4	8	14
2.5 Maintenance and Inspection Department	(0)	(3)	(6)	(20)	(18)	(47)
- Maintenance Management	0	1	1	2	2	6
- Mechanical Section	0	0	1	5	4	10
- Electrical Section	0	1	1	5	4	11
- Instrumental Section	0	0	1	4	4	9
- Civil Construction Section	0	0	1	1	2	4
- Inventory Section	0	1	1	3	2	7
2.6 Product Handling Department	(0)	(2)	(5)	(5)	(30)	(42)
- Storage Management	0	2	1	1	8	12
- Bagging Section	0	0	1	1	10	12
- Loading Section	0	0	1	1	10	12
- Ammonia/Sulfur Receiving	0	0	1	1	4	6
- Phosphate Rock Receiving	0	0	1	1	4	6
2.7 Technical and Development Department	(0)	(4)	(5)	(10)	(20)	(39)
- Production Management	0	1	1	2	2	6
- Development and Engineering Section	0	1	1	2	2	6
- Analytical Laboratory	0	1	1	2	12	16
- Training Section	0	1	1	2	2	6
- Product Sales Services	0	0	1	2	2	5
3. Total Personnel for the Project	7	22	34	77	158	298

Notes: 1) Additional contract laborers for product bagging and loading is assumed during peak shipping season.

2) During annual maintenance work for 35 days, additional maintenance supervisor and labor are contracted (Vendor specialist; 10, Inspector; 15, Laborer; 150, Total; 175 persons) whose costs are included in maintenance cost for financial analysis.

Table AV-6-3 PROJECT INVESTMENT COST ESTIMATE

Feasibility Study: On the Establishment of a Phosphate Fertilizer Plant in Argentine Republic
 Project: Phosphate Fertilizer Plant, PF-5
 Product: Monoammonium Phosphate (MAP)/Diammonium Phosphate (DAP), Bagged
 Capacity: 72,409 TPY of MAP (or 77,840 TPY of DAP)
 Location: Bahía Blanca, Buenos Aires, Argentine

Project Investment Cost Estimate (USD, Million)			
	Foreign Currency Component	Local Currency Component	Total
1. Land Acquisition	0.00	0.98	0.98
2. Site Preparation	0.00	0.50	0.50
3. Plant Direct Cost	16.71	20.28	36.99
3.1 Equipment and Materials, FOB	13.94	5.53	19.47
(1) Sulfuric Acid Plant	3.48	0.87	4.35
(2) Phosphoric Acid Plant	3.83	1.27	5.10
(3) Monoammonium Phosphate Plant	2.63	1.12	3.75
(4) Utility Plant	1.15	0.35	1.50
(5) Storage and Material Handling Facility	2.60	1.12	3.72
(6) Auxiliary Facility	0.25	0.80	1.05
3.2 Spare Parts, FOB	1.02	0.15	1.17
3.3 Catalysts and Chemicals, FOB	0.30	0.00	0.30
3.4 Civil Materials, CIF	0.80	7.75	8.55
3.5 Construction and Erection Labor	0.65	6.85	7.50
4. Construction and Erection Equipments	0.20	0.75	0.95
5. Freight, Insurance & Local Handling	2.38	0.83	3.21
5.1 Ocean Transport	2.09	0.00	2.09
5.2 Unloading and Inland Transport	0.00	0.53	0.53
5.3 Tax, Duty, and Insurance	0.29	0.30	0.59
6. Indirect Field Expenses	0.10	0.28	0.38
7. Engineering Services	2.49	0.44	2.93
7.1 General Contractor's Fee	1.56	0.20	1.76
7.2 Supervision and Service Man	0.93	0.24	1.17
8. Project Management Services	0.35	0.15	0.50
8.1 Construction and Erection Advisor	0.30	0.10	0.40
8.2 Operation and Maintenance Advisor	0.05	0.05	0.10
9. Base Project Cost, BPC (Without Taxes) -1983	22.23	24.21	46.44

Figure AV-6-3 PROJECT IMPLEMENTATION SCHEDULE

Project: Phosphate Fertilizer Plant, PF-5
 Product: Monoammonium Phosphate/Diammonium Phosphate Fertilizer
 Location: Bahía Blanca, Buenos Aires, Argentine
 Feasibility Study: On the Establishment of a Phosphate Fertilizer Plant in the Argentine Republic

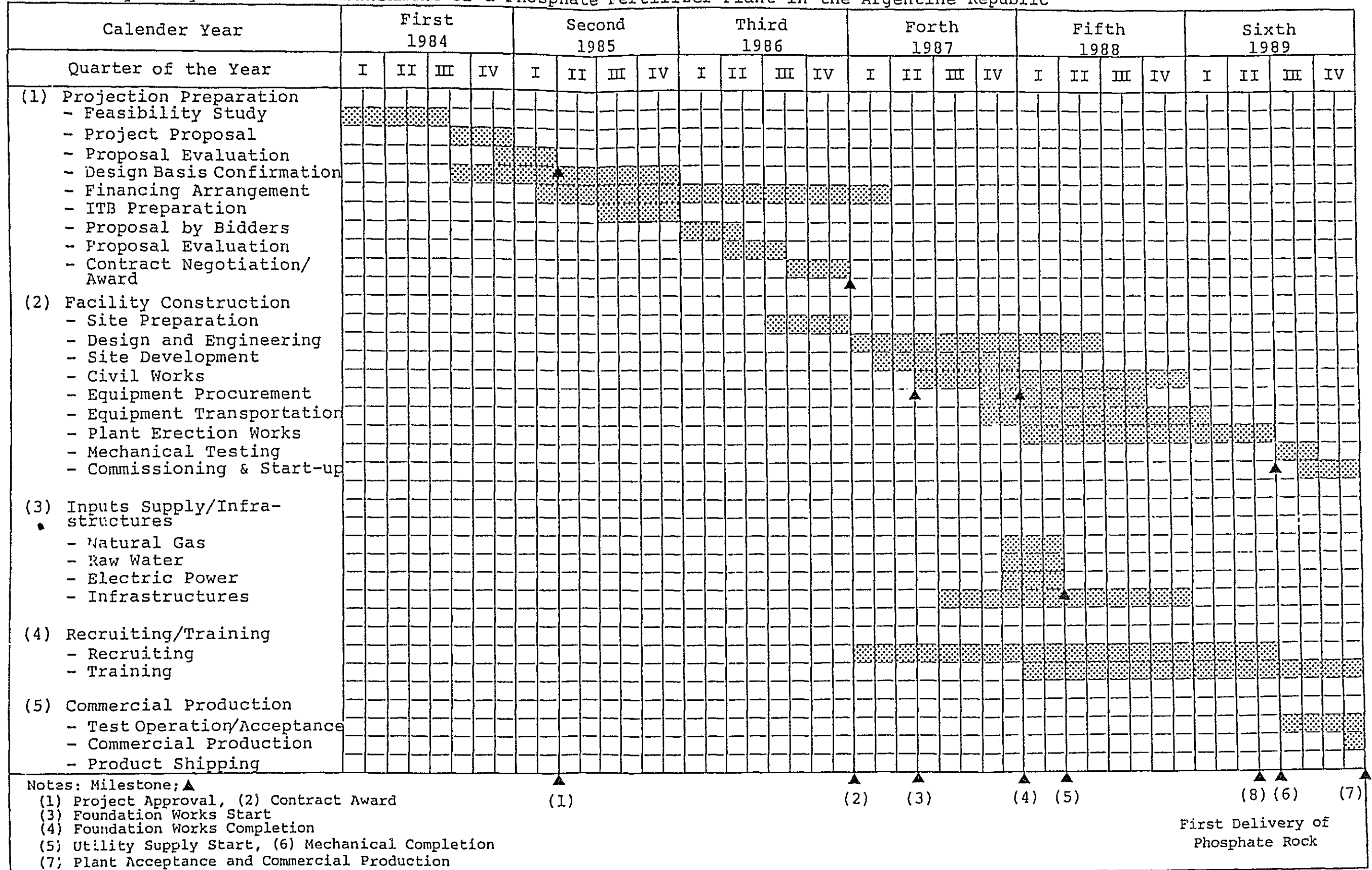

Annex V-7

PROJECT DESCRIPTION FOR PHOSPHATE FERTILIZER PLANT

PF - 6 ... NP/CAN

Nitrophosphate and Calcium Ammonium Nitrate
Production by Ammonia Import

PROJECT DESCRIPTION FOR PHOSPHATE FERTILIZER PLANT
PF - 6... NP/CAN

Nitrophosphate and Calcium Ammonium Nitrate Production
by Ammonia Import

1. Project Outline

The proposed phosphate fertilizer plant project is to produce nitrophosphate (20.8-20.8-0.0) by nitric acid decomposition of phosphate rock which will be recovered at the phosphate rock concentration plant of non-magnetic tails at HIPASAM, Sierra Grande, Argentine.

Major raw materials are phosphate rock, liquid ammonia and natural gas, and as intermediates, carbon dioxide, nitric acid, calcium nitrate, ammonium nitrate and calcium carbonate are produced in the plant. The final product is granular nitrophosphate fertilizer (NP) in bag and a co-product of calcium ammonium nitrate (CAN) which is straight nitrogen fertilizer in bag is also produced. Liquid ammonia is to be imported because at present, no surplus ammonia is domestically available in Argentine. Carbon dioxide is recovered from the flue gas of steam generation which utilize natural gas as fuel in the plant.

Design capacity of the nitrophosphate production plant is 551 TPD of NP and 470.4 TPD of CAN, and annual production in 297 days is 163,666 TPY of NP and 139,709 TPY of CAN.

The analysis of CAN is (26.0-0.0-0.0) and the weighted average analysis of the final product of NP and CAN is (23.19-11.22-0.0) with daily production of 1,020.5 TPD at the plant.

Instead of the production of CAN, the production of ammonium nitrate [AN (34.5-0.0-0.0)] is also possible at the plant according to the market requirements.

The experimental tests for the applicability of the phosphate rock at nitrophosphate fertilizer production were carried out at small scale batch tests (2.0kg/Batch) at Norsk Hydro, Norway and the experimental results were incorporated into the conceptual design of the NP/CAN plant project as is explained hereunder.

The major facility in the plant is as follows:

Process Plant;

-Carbon Dioxide Recovery	115.1 TPD
-Nitric Acid	534.0
-Nitrophosphate	551.1
-Calcium Ammonium Nitrate	470.4

Utility Plant;

-Electric Power Receiving	9 MW
-Natural Gas Receiving	5 MMSCFD
-Raw Water Treatment	6,000 TPD
-Water Polisher	2,000
-Cooling Water Tower	7,000 TPH
-Steam Generation	45
-Waste Water Treatment	6,000 TPD

Storage and Material Handling Facility;

-Phosphate Rock	10,000 Ton
-Product - NP and CAN	105,000
-Product Bagging	280 TPH
-Ammonia, Port Area	10,000 Ton
, Plant Site	1,000
-Nitric Acid	9,000

Auxiliary Facility

-Administration Building	1,000 m ²
-Maintenance Shop and Storage	2,500
-Others	

The total area for the project site is 135,000 m² (450m x 300m).

2. Plant Description

The detailed description for process plant, utility plant, storage and material handling and auxiliary facility are explained hereafter.

2-1 Carbon Dioxide Recovery Plant

(1) Introduction

The carbon dioxide recovery plant has a 115 TPD production capacity of gaseous carbon dioxide from the flue gas of steam generation plant (Capacity of 45 TPH of Steam) which is included in the proposed nitrophosphate plant. The carbondioxide is utilized as an intermediate raw material for the conversion of calcium nitrate into ammonium nitrate and calcium carbonate.

The process is to use monoethanol amine as absorbent of carbon dioxide and the process plant consists of absorption and stripping section of carbon dioxide.

(2) Process Description

The flue gas from the steam generation plant is processed at the monoethanol amine scrubber tower for carbon dioxide removal.

The carbon dioxide rich solution from the absorber is let down into a stripper where absorbed carbon dioxide is flashed out by heating the solution in the stripper tower. The regenerated monoethanol amine is fed back to

the scrubber tower. The expected recovery of carbon dioxide is 85% and the maximum allowable oxygen and sulfur oxides in the flue gas by monoethanol amine process plant is 6.0 volume % and 0.5 ppm, respectively.

(3) Product Specification

The plant is to produce a 115 TPD of gaseous carbon dioxide (as 100% CO₂) under normal operating conditions. The specification of product is as follows;

Gaseous Carbon Dioxide;

Daily Production	115 TPD
Analysis (Dry, Volume Basis)	
-CO ₂	99.0 %
-Inert Gases	1.0
-Total Sulfur	0.5 ppm
-Moisture	Saturated

Conditions

-Temperature	40.0°C
-Pressure	0.20 atg

(4) Raw Material, Utility, Chemicals and Catalyst Consumption

The consumption at the carbon dioxide recovery plant under normal operating conditions are as follows:

	<u>Production and Consumption</u>		
	<u>Unit Product</u>	<u>Hourly</u>	<u>Daily</u>
Production;			
-Gaseous Carbon Dioxide, Ton	1.000	4.79	115.0
Consumption;			
-Flue Gas from the Steam Generation Plant,* (CO ₂ : 9.1 wt%), Ton	8.178	39.17	940.5
-Electric Power, kWh	111.09	532.12	12,927.4
-Cooling Water, Ton	277.73	1,330.31	31,927.4
-Condensate , Ton	0.21	1.00	24.0
-Steam, Ton	2.592	12.42	298.0
-Monoethanol Amine, kg	0.762	3.65	87.6
-Other Chemicals, US\$	0.250	1.20	28.8

* The tonnage of flue gas at the steam generation plant is 67.5 TPH and its composition is as follows;

N ₂	72.76 wt%	72.38 vol%
O ₂	2.01	1.75
CO ₂	14.39	9.11
H ₂ O	<u>10.83</u>	<u>16.76</u>
	100.00	100.00

2-2 Nitric Acid Plant

(1) Introduction

The nitric acid plant has a 534 TPD of nitric acid production capacity. Raw material is liquid ammonia which is oxidized to produce nitric acid gas on the platinum catalyst under high temperature and pressure.

The product nitric acid is captively consumed at the nitrophosphate plant for the decomposition of phosphate rock.

The plant consists of three major sections:

- Raw Material Preparation
- Ammonia Combustion
- Absorption and Bleaching

(2) Process Description

The stoichiometric reaction of nitric acid production from ammonia is follows:

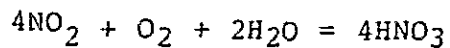
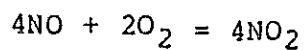
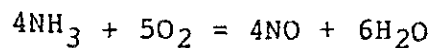

Overall reaction is;

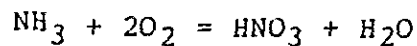

(a) Raw Synthesis Preparation

Raw material liquid ammonia is sent to evaporator where it is evaporated to gaseous ammonia by heating with water. Oil and water are separated from ammonia in the evaporator.

The gaseous ammonia is superheated, filtered and then sent to the ammonia and air mixer. The air passes through filter and is compressed and split into primary and secondary streams. Primary air is sent to gas mixer and secondary air is fed into the bleacher.

(b) Ammonia Combustion

Ammonia and air mixture flows downwards in the converter. A distribution system allows homogeneous flow over the surface of the platinum-rhodium gauzes catalyst, which are set on stainless steel supports.

The temperature of nitrous gases, nitrogen and oxygen resulting from ammonia combustion is about 850°C and its heat energy is recovered at several heat exchangers and steam boiler.

(c) Absorption and Bleaching

After cooled down by cooling water in the water condenser, the weak acid is condensed and fed into the absorber, the gas stream passes through the separator, is mixed with the secondary air and is compressed.

Heat exchanger recovers the heat of compression in warming up the tail gas stream. Then, the gas passes through the condenser cooled by water from absorber.

The gas stream together with the acid condensate are fed into absorber, equipped with perforated trays and cooling coils. Part of these are fed by chilled water from ammonia evaporator. Process water is fed at the top of the absorber and the acid at design concentration is extracted from the bottom.

The product acid from absorber is fed to the bleacher of tray tower. The bleaching is completed by stripping with secondary air, which is pre-cooled in heat exchanger by condensate from the steam turbine.

The air from the bleacher, containing nitrous gases, is mixed with the main stream at inlet of the gas compressor.

The product nitric acid has concentration of 60% as HNO_3 and is sent to storage tanks and nitrophosphate plant.

(3) Product Specification

The plant is to produce a 534 TPD of nitric acid product (as 100% HNO_3 and in concentration of 60% of HNO_3 aqueous solution) under normal operating conditions.

The specification of such products are as follows:

Nitric Acid;	
-Daily Production	534 TPD
-Analysis	
- HNO_3	60.0 %
- HNO_2	100.0 ppm
-Condition	
-Temperature	30°C
-Pressure	1.0 ata

(4) Raw Material, Utility, Chemicals and Catalyst Consumption

	<u>Production and Consumption</u>		
	<u>Unit Product</u>	<u>Hourly</u>	<u>Daily</u>
Production;			
-Nitric Acid, Ton	1.000	22.25	534.0
Consumption;			
-Ammonia, Ton	0.280	6.23	149.5
-Electric Power, kWh	11.000	244.75	5,874.0
-Boiler Feed Water, Ton	0.900	20.03	480.6
-Cooling Water, Ton	120.000	2,670.00	64,080.0
-Steam (Export), Ton	0.380	8.46	202.9
-Platinum Catalyst*, g	0.100	2.23	53.4

* The consumption of platinum catalyst is equivalent to USD 1.50/Ton of nitric acid on the date of base project cost estimate.

2-3 Nitrophosphate Plant

(1) Introduction

The nitrophosphate plant has a 551 TPD production capacity by using phosphate rock, nitric acid, ammonia and carbon dioxide as major raw materials.

In the plant, phosphate rock is decomposed by nitric acid and by deep cooling, calcium nitrate crystal are separated to remove calcium content from nitrophosphate fertilizer for increasing water solubility of P₂O₅ in final

product. Separated calcium nitrate is then converted into ammonium nitrate and calcium carbonate and a portion of ammonium nitrate is incorporated as nitrogen source into nitrophosphate (NP) and the rest of ammonium nitrate is granulated by mixing with calcium carbonate to produce calcium ammonium nitrate fertilizer (CAN) in the calcium ammonium nitrate plant. Instead of CAN, ammonium nitrate is also produced in the plant, if required.

The product nitrophosphate and calcium ammonium nitrate are sent to bagging plant directly or indirectly through bulk product storage. The bagged product is shipped directly or indirectly through bagged product storage.

Surplus calcium carbonate will be sold as liming material or discarded as harmless inert materials in pond.

The process plant consists of three major sections:

- Wet Section
- Dry Section
- Calcium Nitrate Conversion Section

The product grade of NP is (20.8-20.8-0.0) but according to the market demand NPK grades such as (26.0-13.0-0.0) and (15.4-15.4-15.4) are also produced at the plant by adjusting raw material and process conditions.

The raw material phosphate rock will be recovered at the proposed phosphate rock concentration plant at Sierra Grande, Argentine and its specification is shown in Table AV-7-1.

Table AV-7-1 ANALYSIS OF PHOSPHATE ROCK EXTRACTED FROM IRON ORE CONCENTRATION
NON-MAGNETIC TAILS OF HIPASAM, SIERRA GRANDE, ARGENTINE

(1) CHEMICAL ANALYSIS

As Element	Weight Percent	As Oxide	Weight Percent	Equivalency for 100g Sample
P	15.56%	P ₂ O ₅	35.65%	(-) 1.507
C (Carbonate)	0.09	CO ₂	0.33	(-) 0.015
F	1.50	F	1.50	(-) 0.079
Cl	0.01	Cl	0.01	(-) 0.0005
OH	-	OH	(3.88)	(-) (0.2285)
S (Total)	-	S and Oxides	-	(-) -
S (Sulfide)	0.48	S	0.48	(-) 0.030
S (Sulfate)	-	SO ₃	-	(-) -
Si	1.98	SiO ₂	4.24	(-) 0.141
Fe (Total)	5.80	Fe Oxides	7.67	(+) 0.233
Fe (II)	4.36	FeO	(5.61)	(+) (0.156)
Fe (III)	1.44	Fe ₂ O ₃	(2.06)	(+) (0.077)
Al	1.46	Al ₂ O ₃	2.06	(+) 0.162
Mn	-	MnO	-	(+) -
Ca	31.66	CaO	44.30	(+) 1.580
Mg	0.22	MgO	0.36	(+) 0.018
Na	0.15	Na ₂ O	0.20	(+) 0.006
K	0.07	K ₂ O	0.08	(+) 0.002
Others	-	Others	-	-
Free Moisture	0.14	Free Moisture	0.14	-
Organics	-	Organics	-	-
<u>Ignition Loss</u>	<u>1.68</u>	<u>Ignition Loss</u>	<u>1.68</u>	-
Total	65.95	Sub-total	102.58	(-) 2.001
		Adjustment for F	(-) 0.63	(+) 2.001
		Total	101.95	(+) 0.000

(2) PHYSICAL PROPERTY

Color	Gray
Size Distribution (Tyler Mesh and Millimeter)	
(+) 400 Mesh (0.0370 mm)	15.9%
(+) 468.4 (0.0316)	18.4
(+) 677.8 (0.0219)	36.1
(+) 993.3 (0.0149)	52.5
(+) 1,309.7 (0.0113)	64.5
(-) 1,309.7 (0.0113)	35.4
	100.0
Density	3.27
Bulk Density - Packed	1.67
- Loose	1.27
Angle of Reponse	43.0°
Free Moisture of Filter Cake, %	13.0
Specific Surface Area, cm ² /gr	2,770

(3) FERTILIZER PROPERTY

	Weight Percent	Solubility Percent
Total P ₂ O ₅	35.65%	100.0%
Nitric Acid Soluble P ₂ O ₅	35.60	99.9
Hydrochloric Acid Soluble P ₂ O ₅	35.11	98.5
Citric Acid Soluble P ₂ O ₅	7.96	22.3
Formic Acid Soluble P ₂ O ₅	5.69	16.0
Ammonium Citrate Soluble (AV) P ₂ O ₅ (Neutral)	0.00	0.0
Water Soluble P ₂ O ₅	0.00	0.0

Notes: - Sample tails (Fe=27.53%, P₂O₅=7.08%) were taken on October 6, 1983 at HIPASAM and concentration test and analysis were made at NIKKO Consulting and Engineering Co. Ltd., Japan in January, 1984. Recovery of P₂O₅ is 55.5%. Fertilizer property was determined at Nissan Chemical Industries, Ltd., Japan in March, 1984.
- Ignition loss is measured by heating at 900°C for 0.5 hours.
- Free moisture is measured by heating at 105°C for 5.0 hours.
- (OH) is estimated to keep balanced equivalency.

(2) Process Description

The typical stoichiometric reactions of nitrophosphate production is as follows:

Decomposition;

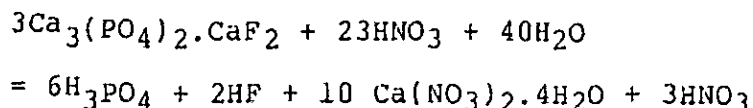

NP Production;

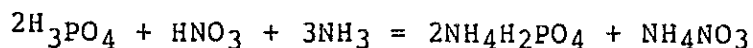

Calcium Nitrate Conversion;

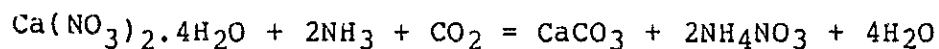

(a) Wet Section

The wet section consists of digestion, crystallization, calcium nitrate filtration and neutralization part.

The phosphate rock feed enters the rock surge bin and flows, after weighing, to the digester where the rock is reacted with nitric acid in order to convert the insoluble phosphate into soluble form.

A small quantity of excess acid is used to maintain the optimum conditions during digestion and subsequent crystallization. A part of nitric acid is first used for washing calcium nitrate crystals and then enters as wash acid into the digester.

The following main reactions take place in the digestion tanks.

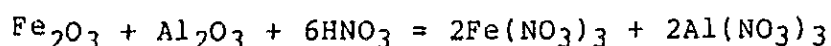
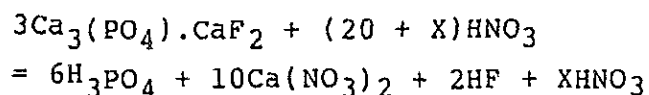

In order to decompose the phosphate rock with nitric acid, a series of digestion tanks is required and nitric acid concentration of 58-60% is applied for complete reaction.

During decomposition of the phosphate rock, the effluent gases containing HF, SiF₄, NO_x, CO₂ and water vapor are vented to the effluent treatment section to control the pollutant emissions to the atmosphere.

The digested solution from the crystallizer feed tank is fed to the crystallizers.

In the crystallizers, the digested solution is cooled to obtain the required quality of product by using a coolant prepared in the refrigeration system. The ratio of the contents of dicalcium phosphate and ammonium phosphate in the product is determined by the degree of calcium removal. Dicalcium phosphate is soluble in citrate solution, while ammonium phosphate is soluble both in citrate solution and in water.

Consequently, to achieve a high percentage of water soluble phosphate in the product, a large amount of calcium has to be removed in crystallization. The solubility of calcium nitrate in this solution decreases with decreasing temperature.

The suspension from the crystallizers contains uniform crystals of calcium nitrate tetrahydrate [Ca(NO₃)₂.4H₂O] which are separated from mother liquor at the rotating two stage vacuum filters. In the first filter, the mother liquor is separated from calcium nitrate crystals. Some of the mother liquor remains in the crystal cake, which is carried over to the second filter and are washed with nitric acid and water, which is recycled to the digester.

The filtrate liquor from the filter goes to the liquor tank, while crystals of calcium nitrate tetrahydrate are fed into the melting tank, from where it is sent to the calcium nitrate conversion section to recover nitrogen as ammonium nitrate.

The filtrate liquor from the liquor tank is sent to the neutralizer, in which the neutralization is carried out with gaseous ammonia.

The following main reactions take place in the neutralizing tank under controlled conditions;

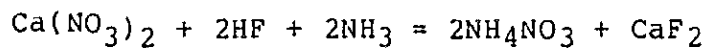
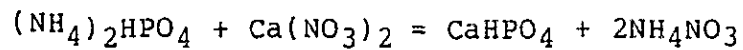
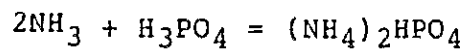
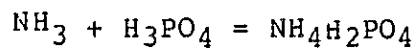
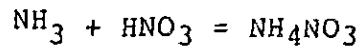

The neutralized liquor consists mainly of precipitated calcium phosphates, ammonium nitrate, monoammonium phosphate in a mixture.

In addition, reactions with impurities in the rock take place in this section. Therefore, in order to obtain favorable flow properties and to avoid the formation of insoluble phosphates, neutralization must be carried out under controlled conditions to adjust the type of phosphate rock used.

A portion of ammonium nitrate solution recycled from the calcium nitrate conversion is added to the liquor to obtain designed analysis of nitrogen and phosphate in the final product of nitrophosphate fertilizer.

(b) Dry Section

After neutralization, the liquor is sent to evaporator to reduce moisture.

The evaporator is designed to avoid scaling and precipitation of phosphates on the heating surface in the evaporators.

The concentrated liquor from the evaporator is fed to the pugmill type granulator, in which liquor is mixed with the recycle fines to form granular nitrophosphate product.

The recycle comprises the oversize granules separated in the oversize screen and crushed, the fines separated in the undersize screen and some amount of product size of granules separated in the undersize screen.

After granulation the product is dried in the rotary drum dryer where steam heated hot air is supplied. Then the dried granules are transported via belt conveyors and bucket elevator to the screens for classification. Apart from the recycle portion, the remaining granules for product size are sent to the cooler.

The off gas of the dryer is vented to the atmosphere by the dryer exhaust fan after dust collecting in the cyclones.

The product granules are cooled by air in the fluidized cooler. Then they are conditioned in coating drum with coating agent and oil to assure product with satisfactory storing property.

(c) Calcium Nitrate Conversion Section

The molten calcium nitrate from melting tank is transferred into the conversion reactor. Ammonia and carbon dioxide are absorbed in ammonium nitrate solution in the absorption tower and the absorbed liquor of ammonium carbonate is fed to the conversion reactor through the tower liquor cooler.

In the reactor the conversion of calcium nitrate into ammonium nitrate and calcium carbonate takes place by the following reaction;

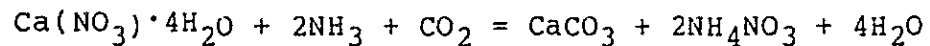

Ammonium nitrate solution with suspension of calcium carbonate overflows to the tank and is filtrated at the filter and the calcium carbonate cake is washed with water, and sent to the calcium ammonium nitrate plant.

On the other hand, the filtrate ammonium nitrate solution is further filtered in the polishing filter to remove impurities in ammonium nitrate solution and then fed to the pH control tank in which excess ammonia in the solution is neutralized with nitric acid to avoid loss of ammonia.

The dilute ammonium nitrate solution is concentrated at the evaporator and sent to the nitrophosphate granulator and calcium ammonium nitrate plant.

(3) Product Specification

The plant is to produce a 551 TPD of nitrophosphate fertilizer in bulk, a 291.9 TPD of ammonium nitrate solution and a 217.6 TPD of calcium carbonate under normal operating conditions.

The specification of such products are as follows:

Nitrophosphate (NP);

-Daily Production	551 TPD
-Analysis	
-Total Nitrogen	20.8 %
-Ammoniacal Nitrogen	11.4
-Nitrate Nitrogen	9.4
-Total P ₂ O ₅	21.1
-Available P ₂ O ₅	20.8
-Water Soluble P ₂ O ₅	15.8
-Free Moisture	0.6
-Condition	
-Temperature	40°C
-Pressure	1.0 ata
-Size Distribution	
(+) 4.0	3.0%
(-) 4.0, (+) 1.0	97.0
(-) 1.0	3.0
-Bulk Density	0.97
-Angel of Repose	32°
-Crushing Hardness (2.0 mm)	4.5 kg

Ammonium Nitrate Solution;

-Daily Production, Dry	291.9 TPD
-Analysis, Dry Weight Basis	
-Total Nitrogen	35.0%
-Ammoniacal Nitrogen	17.5
-Nitrate Nitrogen	17.5
-Moisture	8.0
-Condition	
-Temperature	120.0°C
-Pressure	1.0 ata

Calcium Carbonate;

-Daily Production, Dry	217.6 TPD
-Analysis,	
-CaCO ₃	85.7%
-Moisture	15.0
-Conditions	
-Temperature	80.0°C
-Pressure	1.0 ata
-Size Distribution	
(-) 0.05 mm	80 %

(4) Raw Material, Utility, Chemicals and Catalyst Consumption

	<u>Production and Consumption</u>		
	<u>Unit Product</u>	<u>Hourly</u>	<u>Daily</u>
Production;			
-Nitrophosphate, Ton, Bulk	1.000	22.96	551.1
-Ammonium Nitrate Melt, Ton	0.635	14.58	349.9
-Calcium Carbonate, Dry, Ton	0.395	9.07	217.7
Consumption;			
-Liquid Ammonia, Ton	0.275	6.31	151.5
-Nitric Acid, Ton	0.960	22.04	529.0
-Urea, Ton	0.004	0.09	2.3
-Phosphate Rock, (P ₂ O ₅ 35.65%), Ton	0.599	13.75	330.0
-Carbon Dioxide, Ton	0.204	4.68	112.4
-Silica, Ton	0.004	0.09	2.4
-Coating Oil, Ton	0.0004	0.01	0.2
-Electric Power, kWh	119.0	2,732.24	65,580.9
-Cooling Water, Ton	98.0	2,250.08	54,007.8
-Steam , Ton	1.070	24.57	589.6

2-4 Calcium Ammonium Nitrate Plant

(1) Introduction

The calcium ammonium nitrate plant has a 470.4 TPD production capacity by consuming the co-product of ammonium nitrate and calcium carbonate from the nitrophosphate plant.

Product calcium ammonium nitrate (CAN) contains 26% of nitrogen and is one of the major nitrogen fertilizers,

especially in Europe. The product is safe from burning or explosion which was experienced for handling of ammonium nitrate in the past, and is considered as suitable nitrogen fertilizer for dry (not paddy) and/or cool climatic firm fields. The calcium is also effective for preventing the crop damages by salinity of soils.

The process is co-granulation of ammonium nitrate and calcium carbonate at pan granulator. Therefore the product quality of nitrogen content is adjustable according to the domestic market demands. An extreme case is to produce pure ammonium nitrogen, contains 34.5% nitrogen which is also possible to produce in the plant.

The product is sent to bagging plant directly or indirectly through bulk storage. The bagged product is shipped directly or in directly through bagged product storage.

The process plant consists concentration and drying section of raw materials and granulation section.

(2) Process Description

The raw materials of ammonium nitrate solution and wet calcium carbonate, both of them are the co-products at the nitrophosphate plant, are concentrated and dried at first.

Concentrated ammonium nitrate melt is sprayed through a nozzle onto the solid moving bed of dried calcium carbonate powder and recycle fines in the rotating pan type granulator.

The granulated material is fed to the rotating drum for polishing the surface of the product. The polished product is then sent to the cooler and screen separation to obtain uniform sized product. The crushed oversize and undersize material are fed back to the granulator for further processing.

The product size material is fed to the rotating drum and coated with coating agent for anti-caking treatment.

The product is transferred to the bulk storage or to the bagging plant.

(3) Product Specification

The plant is to produce a 470.4 TPD of calcium ammonium nitrate in bulk, under normal operating conditions.

The specification of the products is as follows:

Calcium Ammonium Nitrate (CAN);	
-Daily Production	470.4 TPD
-Analysis	
-Total Nitrogen	26.0 %
-Ammonical Nitrogen	13.0
-Nitrate Nitrogen	13.0
-Free Moisture	0.4
-Conditions	
-Temperature	40.0°C
-Pressure	1.0 ata
-Size Distribution	
(+) 4.0 mm	3.0%
(-) 4.0, (+) 1.0	95.0
(-) 1.0	2.0
-Bulk Density	1.05
-Angel of Repose	32.0°
-Crushing Hardness (2.0 mm)	4.5 kg

(4) Raw Material, Utility, Chemicals and Catalyst Consumption

	<u>Production and Consumption</u>		
	<u>Unit Product</u>	<u>Hourly</u>	<u>Daily</u>
Production;			
-Calcium Ammonium Nitrate, Ton	1.000	19.60	470.4
Consumption;			
-Ammonium Nitrate, Dry, Ton	0.743	14.56	349.5
-Calcium Carbonate*, Dry, Ton	0.257	5.04	120.9
-Diatomaceous Earth, Ton	0.010	0.20	4.7
-Electric Power, kWh	31.0	607.60	14,582.4
-Cooling Water, Ton	4.00	78.40	1,881.6
-Steam, Ton	0.190	3.72	89.4

* Production of calcium carbonate at the nitrophosphate plant is 217.6 TPD, therefore daily 96.7 ton of calcium carbonate is surplus for sales or disposal.

2-5 Utility Plants

The major utility plants required for the nitrophosphate plant are designed to have following capacities;

	<u>Facility Capacity</u>	<u>Normal Demand</u>
Electric Power Receiving, kWh/h	9,000	7,411
Natural Gas Receiving, MMSCFD	5.0	3.1
Raw Water Treatment, TPD	7,000	5,592
Water Polisher, TPH	2,000	1,476
Steam Generation, TPH	45.0	41.5
Cooling Water Tower, TPH	7,000	6,176
Plant and Instrument Air, Nm ³ /h	3,000	1,500
Inert Gas Generation, Nm ³ /h	200	150
Waste Water Treatment, TPD	7,000	5,000
Emergency Power Generation, kWh/h	1,000	1,000

2-6 Storage and Material Handling Facility

The major facilities for raw materials, intermediates, and products receiving, storage, bagging and other material handlings are designed to have following capacities;

	<u>Facility Capacity</u>	<u>Normal Daily Requirements</u>
Storage Facilities;		
-Phosphate Rock, Ton	10,000	336.7
-Liquid Ammonia, Ton	11,000	303
-Nitric Acid, Ton	9,000	543
-Nitrophosphate and Calcium Ammonium Nitrate, Ton		
, Bulk	100,000	1,022
, Bagged	5,000	1,022
Bagging and Loading Facility		
-Nitrophosphate and Calcium Ammonium Nitrate	280 TPH	43 TPH

2-7 Auxiliary Facilities

The major auxiliary facilities for the management of the operation, maintenance and accomodation at the phosphate fertilizer plant is designed to have following specifications;

	<u>Facility Specification</u>
Administration Building	1,000 m ₂
Laboratory	300
Canteen	400
Garage and Gate House	200
Maintenance Shop	1,200
Storage House	1,200
Fire Fighting House	200
Others	-

3. Project Summary

3-1 Product and Production

The proposed nitrophosphate fertilizer plant project is to produce nitrophosphate and calcium ammonium nitrate as major products and calcium carbonate as by-product from phosphate rock and liquid ammonia as major inputs.

The brief specification of the products and production are summarized as below:

<u>Product</u>	<u>Fertilizer Specification, %</u>			<u>Production, Ton</u>	
	<u>Av-</u>		<u>W-</u>	<u>Daily</u>	<u>Annual</u>
	<u>P-N</u>	<u>P₂O₅</u>	<u>K₂O</u>		
Nitrophosphate	20.8	20.8	0.0, Bagged	551.1	163,666
Calcium Ammonium Nitrate	26.0	0.0	0.0, Bagged	470.4	139,709
Calcium Carbonate	0.0	0.0	0.0, Bulk	96.7	28,720

The limiting factor for the production is the availability of phosphate rock which is recovered from the non-magnetic tails of HIPASAM, Sierra Grande, Río Negro. The total available phosphate rock is 100,000 TPY and the losses for transportation and handling of 2.0% is reduced from the production calculation.

3-2 Overall Consumption

The overall consumption of raw material, utility, catalysts and chemicals for the proposed project is calculated for the financial

analysis of the project which includes losses during storage, processing and bagging of the product, and also consumption for utility and auxiliary facilities.

In these calculation the by-product calcium carbonate is not credited for financial analysis.

	Production and Consumption		
	Unit Product	Hourly	Daily
Production			
-Nitrophosphate, Ton	0.5395	22.96	551.1
-Calcium Ammonium Nitrate, Ton	0.4605	19.60	470.4
<u>-Calcium Carbonate, Ton</u>	<u>(0.0947)</u>	<u>(4.03)</u>	<u>(96.7)</u>
Average (23.19-11.22-0.0), Bagged, Ton	1.000	42.56	1,021.5
Consumption;			
-Natural Gas, MMBTU-LHV	2.7303	116.20	2,788.8
-Liquid Ammonia, Ton	0.2996	12.75	306.0
-Phosphate Rock, Ton (P ₂ O ₅ 35.65%)	0.3296	14.03	336.7
-Catalysts and Chemicals*, USD-1963	0.7842	33.38	801.0
-Diatomaceous Earth*, Ton	0.0047	0.20	4.8
-Silica*, Ton	0.0021	0.09	2.1
-Coating*, Ton	0.0002	0.01	0.2
-Monoethanol Amine*, Ton	0.0000858	0.003	0.08
-Raw Water, Ton	5.47	232.98	5,591.5
-Electric Power, kWh	174.13	7,411.00	177,864.0
-Fertilizer Bag, 50kg Net. Sheet	20.20	859.70	20,632.8

* All cost for these catalysts and chemicals is USD 0.955/Ton of weighted average products of NP and CAN.

3-3 Overall Flow Block Diagram

The overall flow block diagram of the nitrophosphate plant showing process plant, utility and auxiliary facilities are illustrated in Figure AV-7-1.

3-4 General Plot Plan

The general plot plan of the nitrophosphate plant showing location of each major facilities are illustrated in Figure AV-7-2. The total site area required is 135,000 m² (450m x 300m)

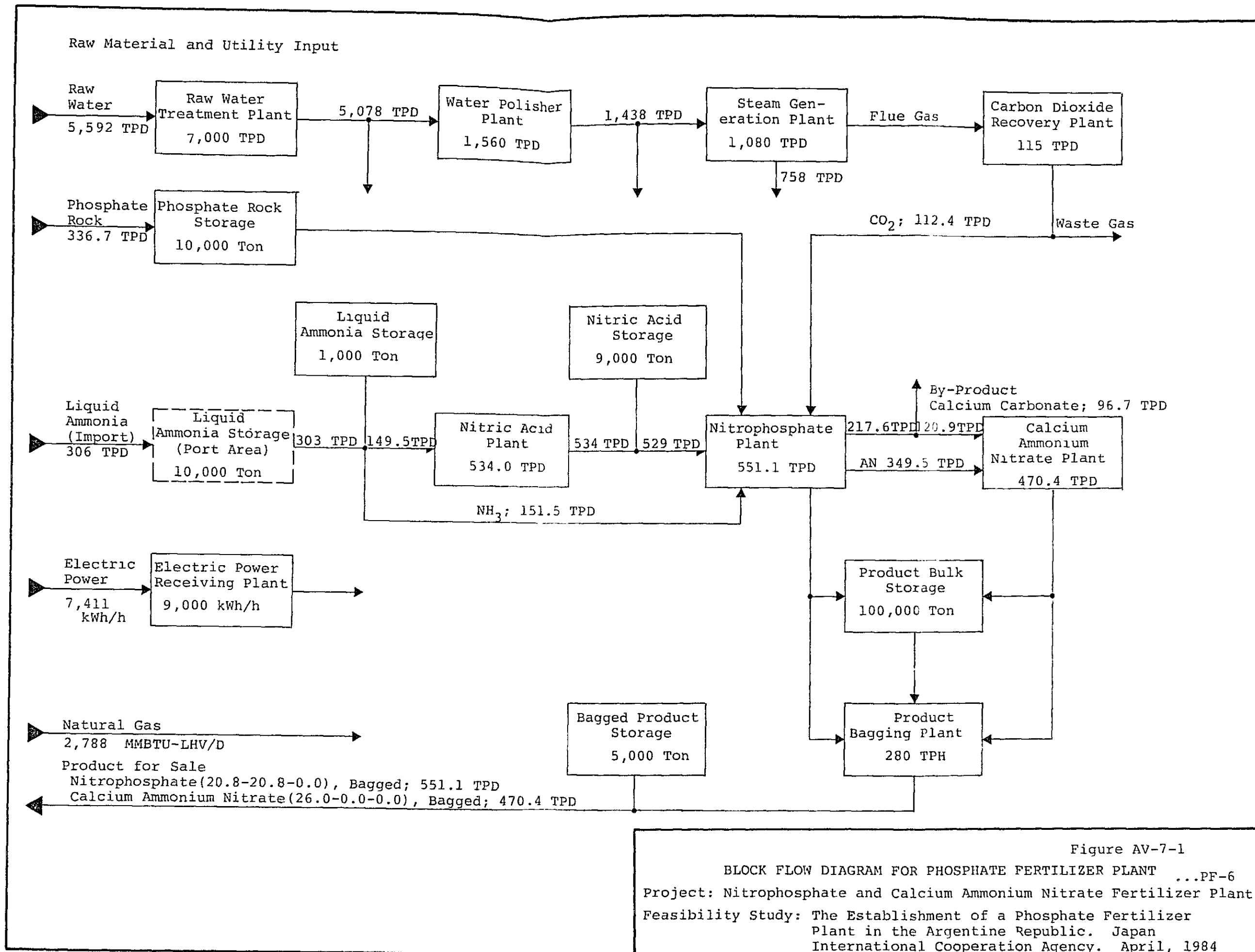

Figure AV-7-1
 BLOCK FLOW DIAGRAM FOR PHOSPHATE FERTILIZER PLANT ...PF-6
 Project: Nitrophosphate and Calcium Ammonium Nitrate Fertilizer Plant
 Feasibility Study: The Establishment of a Phosphate Fertilizer
 Plant in the Argentine Republic. Japan
 International Cooperation Agency. April, 1984

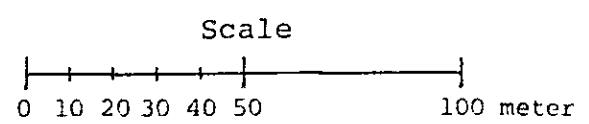
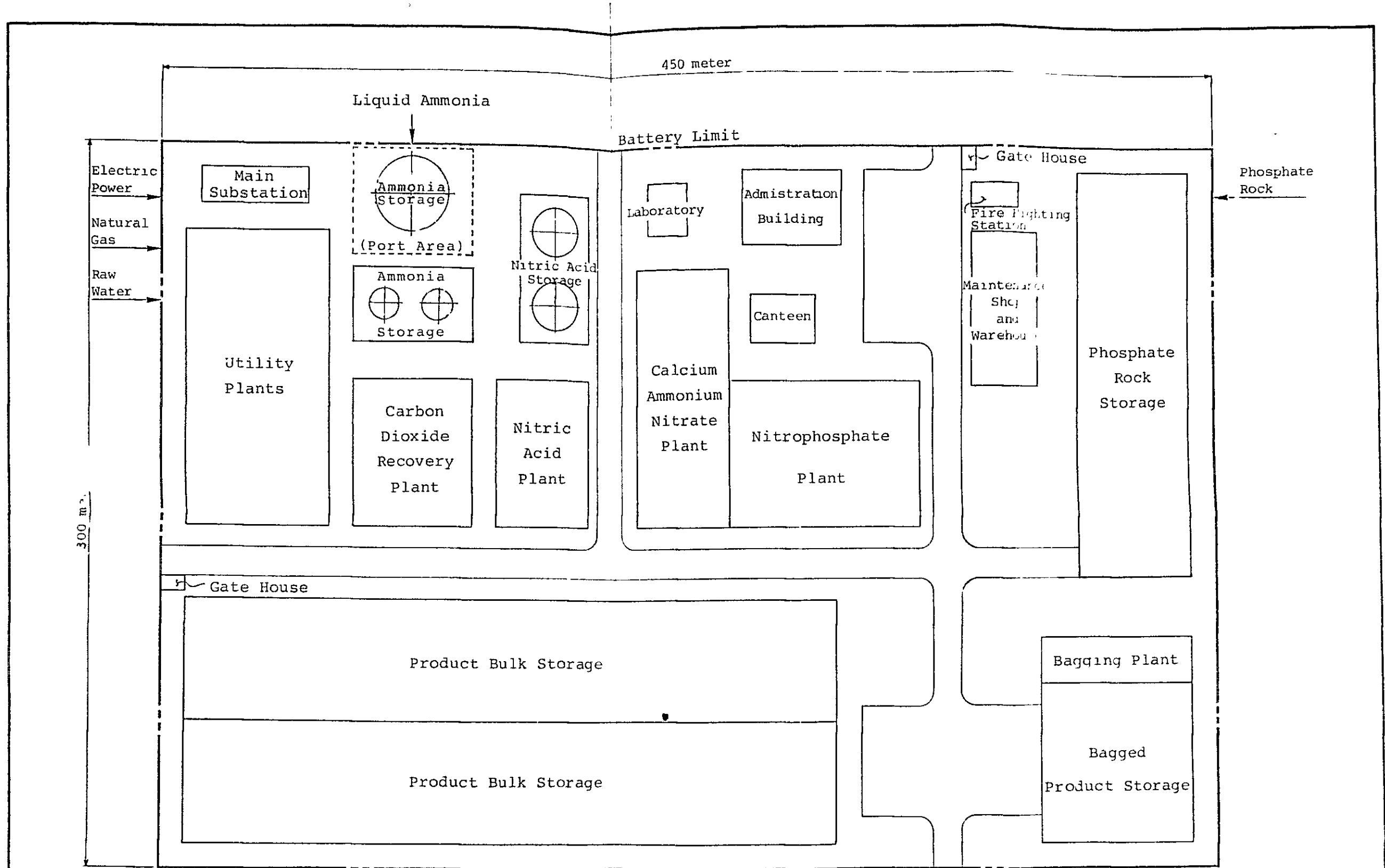

Figure AV-7-2

GENERAL PLOT PLAN FOR PHOSPHATE FERTILIZER PLANT ... PF-6

Project: Nitrophosphate and Calcium Ammonium Nitrate Fertilizer Plan
 Feasibility Study: The Establishment of a Phosphate Fertilizer Plant in the Argentine Republic. Japan
 International Cooperation Agency. April, 1984

Annex V-8

PROJECT DESCRIPTION FOR PHOSPHATE FERTILIZER PLANT

PF - 7 . . . NP/CAN

Nitrophosphate and Calcium Ammonium Nitrate

Production by Ammonia Production

PROJECT DESCRIPTION FOR PHOSPHATE FERTILIZER PLANT
PF - 7... NP/CAN

Nitrophosphate and Calcium Ammonium Nitrate Production
by Ammonia Production

1. Project Outline

The proposed phosphate fertilizer plant project is to produce nitrophosphate (20.8-20.8-0.0) by nitric acid decomposition of phosphate rock which will be recovered at the phosphate rock concentration plant of non-magnetic tails at HIPASAM, Sierra Grande, Argentine.

Major raw materials are phosphate rock and natural gas, and as intermediates, ammonia, carbon dioxide, nitric acid, calcium nitrate, ammonium nitrate and calcium carbonate are produced in the plant. The final product is granular nitrophosphate fertilizer (NP) in bag and a co-product of calcium ammonium nitrate (CAN) which is straight nitrogen fertilizer in bag is also produced. All raw materials for the plant are domestically available in Argentine.

Design capacity of the nitrophosphate production plant is 551 TPD of NP and 470.4 TPD of CAN, and annual production in 297 days is 163,666 TPY of NP and 139,709 TPY of CAN.

The analysis of CAN is (26.0-0.0-0.0) and the weighted average analysis of the final product of NP and CAN is (23.19-11.22-0.0) with daily production of 1,021.5 TPD at the plant.

Instead of the production of CAN, the production of ammonium nitrate [AN, 934.5-0.0-0.0] is also possible at the plant according to the market requirements.

The experimental test for the applicability of the phosphate rock at nitrophosphate fertilizer production were carried out at small scale batch tests (2.0 kg/Batch) at Norsk Hydro, Norway and the experimental results were incorporated into the conceptual design of NP/CAN plant project as is explained hereunder.

The major facility in the plant is as follows:

Process Plant;

-Ammonia	303.0 TPD
-Nitric Acid	534.0
-Nitrophosphate	551.1
-Calcium Ammonium Nitrate	470.4

Utility Plant;

-Electric Power Receiving	20 MW
-Natural Gas Receiving	20 MMSCFD
-Raw Water Treatment	10,000 TPD
-Water Polisher	3,000
-Cooling Water Tower	9,000 TPH
-Steam Generation	20
-Waste Water Treatment	10,000 TPD

Storage and Material Handling Facility;

-Phosphate Rock	10,000 Ton
-Product - NP and CAN	105,000
-Product Bagging	280 TPH
-Ammonia	3,000 Ton
-Nitric Acid	9,000

Auxiliary Facility;

-Administration Building	1,000 m ²
-Maintenance Shop and Storage	2,500
-Others	

The total area for the project site is 135,000 m² (450m x 300m).

2. Plant Description

The outline of the process plant, utility plant, storage and material handling facility and auxiliary facility in the nitrophosphate and calcium ammonium nitrate plant by ammonia production in the plant is described hereunder.

2-1 Amonia Plant

(1) Introduction

The ammonia plant has 303 TPD production capacity by using natural gas as process raw material and utility. Synthesis gas is prepared by steam reforming of natural gas and the major compression of process gases in the plant are supplied by electric power driven reciprocating compressors. The plant also produces carbon dioxide gas with daily tonnage of 400 TPD which is also utilized in the plant for the conversion of calcium nitrate into ammonium nitrate.

The process plant consists of four major sections:

- Raw Synthesis Gas Preparation
- Synthesis Gas Purification
- Compression and Ammonia Synthesis
- Ammonia Recovery

The produced ammonia product is directly fed to the nitric acid plant, nitrophosphate and calcium nitrate conversion plant, respectively and the ammonia is also stored in the ammonia storage tanks when ammonia is surplus and consumed later. The co-product carbon dioxide is fed to the calcium nitrate conversion plant.

(2) Process Description

The stoichiometric reactions of synthesis gas preparation and ammonia synthesis are follows:

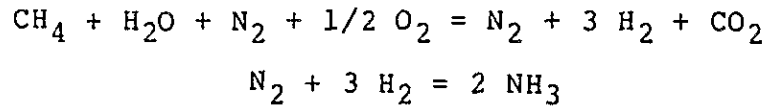

(a) Raw Synthesis Gas Preparation

The natural gas is desulfurized in the hydrotreater and desulfurizer after compression and preheating. Then, it is partially reformed with steam in a primary reformer. The reforming is completed in secondary reformer where the required heat to reform the remaining methane, is supplied by combustion with air. The quantity of air is determined by the stoichiometric amount of nitrogen required for ammonia synthesis. The final stage of preparation is the conversion of carbon monoxide to carbon dioxide by reaction with steam and producing additional hydrogen in the shift converters. Heat energy in the reformed gas is recovered at waste heat boiler.

The shift converters effluent is quenched to its dew point with shift effluent condensate and the gas is then cooled before entering the CO₂ removal system.

A major portion of the shift effluent heat is recovered at the process gas reboiler.

(b) Synthesis Gas Purification

Raw synthesis gas is processed at hot carbonate scrubber for carbon dioxide removal and also methanation for removal of residual CO and CO₂.

The removal of CO₂ from the raw synthesis gas is accomplished by using potassium carbonate solution with organic additives. A small amount of a corrosion inhibitor is also added to the solution. The CO₂ absorption is carried out in two stages. The content of CO₂ in the gas leaving from second stage is reduced to about 0.1%.

The CO₂ rich solution from the absorber is let down into a stripper where CO₂ gas is flushed out and the solution is further regenerated by heat of the low temperature shift converter effluent gas.

Absorber effluent gas is fed to the methanator after heating in the methanator feed heater. Residual carbon monoxide and carbon dioxide in the gas are converted to methane and water by the reaction with a small amount of hydrogen. The concentration of carbon oxides in the treated gas is less than 10 ppm on the dry gas basis.

(c) Compression and Ammonia Synthesis

Fresh synthesis gas compression and recirculating gas compression are accomplished by reciprocating compressor. Fresh synthesis gas is compressed by the synthesis gas compressors and then cooled by the water cooler. Then, fresh synthesis gas is mixed into recirculating gas and delivered to an oil separator for removal of oil mist. This separator consists of the oil separator and ammonia separators.

The recirculating gas is then chilled in the synthesis cold exchanger and the ammonia cooled condenser, in which most of the ammonia in the gas is condensed. The condensed ammonia is separated from the gas in the second ammonia separator.

In the second ammonia separator, all of the water and carbon oxides entering the system with the fresh synthesis gas are removed alongwith the separated liquid ammonia.

After the second ammonia separator, the recirculating gas is preheated before entering the ammonia converter. The preheating is carried out by two heat exchanges, first the synthesis cold exchanger and second the synthesis hot exchanger.

In the synthesis converter the gas flows through tubes extending through the catalyst bed, obtaining additional preheat and simultaneously serving to control temperature in the main catalyst bed. Then the gas is introduced to the adiabatic catalyst bed.

At the catalyst bed, the reaction temperature of synthesis gas with low ammonia content is raised to the optimum temperature by adiabatic reaction, and the ammonia synthesis reaction is promoted with the maximum reaction velocity. Then the synthesis gas is introduced to the main catalyst bed. In the space between the adiabatic catalyst bed and the main catalyst bed the quench gas is introduced so as to keep the optimum temperature of the inlet temperature of the main catalyst bed.

When the gas contacts with catalyst, reaction takes place at first rapidly then with the increase of the ammonia content in the gas the reaction rate decreases. During its passing through the catalyst bed the reacted gas mixture gives its heat to the incoming mixture to keep the optimum reaction temperature.

The recirculating gas from ammonia converter is cooled and all of the heat is recovered by the synthesis waste heat boiler and by the synthesis hot exchanger. The major part of the heat of reaction is recovered in generating the middle pressure steam at 13 atg.

After the synthesis hot exchanger, the recirculating gas is further cooled by water in the water cooled condenser. The major portion of ammonia produced is condensed in the water cooled condenser.

The recirculating gas flows into the first ammonia separator where the produced ammonia is separated from the gas. Then the circulating gas is compressed by the recirculator before mixing with the fresh synthesis gas. A small amount of the gas is withdrawn from this recirculating gas before mixing with the fresh synthesis gas as the high pressure purge gas, keeping the inerts at a reasonable operating level. The liquid ammonia from the first and second ammonia separator is flushed into the letdown drum.

(d) Ammonia Recovery System

The purge gas is processed in an ammonia absorber for recovery of ammonia.

The ammonia absorber consists of two absorption stages. Ammonia in the low pressure purge gas is removed by the

circulating solution from the absorber bottom. Then the gas leaving the first absorption stage is mixed with the high pressure purge gas. In the second absorption stage, this mixture gas is contacted with a highly regenerated solution from the ammonia rectifier. After the removal of ammonia gas, the purge gas is sent to a primary reformer for fuel use.

The major portion for ammonia rich solution from the bottom of the absorber is pumped up and circulated to the absorber through the ammonia circulation cooler and the remaining portion of rich solution is sent to an ammonia rectifier for regenerating of absorption solution. The regenerated solution is withdrawn from the bottom of the ammonia rectifier and is cooled by heat exchanger with the ammonia rectifier feed solution and by cooling water in the ammonia solution cooler, and pumped up to the top of the absorber.

The reboiler for ammonia rectifier is supplied with 40 atg steam. For maintaining the water balance in the ammonia recovery system, high pressure steam is injected into the bottom of ammonia rectifier.

Ammonia vapor stripped from the absorption solution in the ammonia rectifier flows into an ammonia overhead condenser in which ammonia vapor is condensed and condensed ammonia flows into an ammonia separator. Liquid ammonia withdrawn from an ammonia separator is pumped up and a portion of liquid ammonia returned to the top of the ammonia rectifier for reflux stream. A major portion of liquid ammonia is mixed with liquid ammonia from let down drum and shipped out for the production of nitric acid and for the neutralization of nitrophosphate fertilizer production in the plant.

(3) Product Specification

The plant is to produce 303 TPD of liquid ammonia (as 100% NH₃) and 400 TPD of gaseous carbon dioxide (as 100% CO₂) under normal operating conditions.

The specification of such products are as follows:

Liquid Ammonia;

-Daily Production	303.0 TPD
-Analysis	
-NH ₃	99.9 %
-Moisture	0.1
-Oil Content	10.0 ppm
-Condition	
-Temperature	(-)30°C
-Pressure	1.0 ata

Gaseous Carbon Dioxide;

-Daily Production	400.0 TPD
-Analysis (Dry, Volume Basis)	
-CO ₂	99.9 %
-Inert Gases	1.0
-Total Sulfur	0.5 ppm
-Moisture	Saturated
-Oil Content	10.0 ppm
-Condition	
-Temperature	30.0°C
-Pressure	1.1 ata

(4) Raw Material, Utility, Chemicals and Catalyst Consumption

The consumption at the ammonia plant under normal operating conditions are as follows:

	<u>Production and Consumption</u>		
	<u>Unit Product</u>	<u>Hourly</u>	<u>Daily</u>
Production;			
-Liquid Ammonia, Ton	1.000	12.625	303.0
-Gaseous Carbon Dioxide, Ton	1.320	16.667	400.0
Consumption;			
-Natural Gas, MMBTU-LHV	29.76	375.72	9,017.3
-Electric Power, kWh	870.00	10,983.75	263,610.0
-Cooling Water, Ton	220.00	2,777.50	6,666.0
-Steam (Export), Ton	1.31	16.54	396.9
-Condensate (Export), Ton	1.38	17.42	418.1
-Potassium Carbonate*, kg	0.05	0.63	15.2
-Catalysts*, liter	0.32	4.04	97.0

* The consumption of catalysts and chemicals are equivalent to USD 1.75 (CIF value)/Ton of ammonia on the date of base project cost estimate.

2-2 Nitric Acid Plant

(1) Introduction

The nitric acid plant has a 534 TPD of nitric acid production capacity. Raw material is liquid ammonia which is oxidized to produce nitric acid gas on the platinum catalyst under high temperature and pressure.

The product nitric acid is captively consumed at the nitrophosphate plant for the decomposition of phosphate rock.

The plant consists of three major sections:

- Raw Material Preparation
- Ammonia Combustion
- Absorption and Bleaching

(2) Process Description

The stoichiometric reaction of nitric acid production from ammonia is follows:

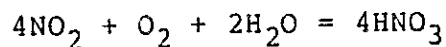
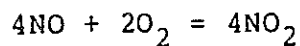
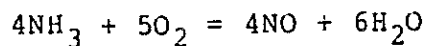

Overall reaction is;

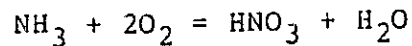

(a) Raw Synthesis Preparation

Raw material liquid ammonia is sent to evaporator where it is evaporated to gaseous ammonia by heating with water.

Oil and water are separated from ammonia in the evaporator. The gaseous ammonia is superheated, filtered and then sent to the ammonia and air mixer. The air passes through filter and is compressed and split into primary and secondary streams. Primary air is sent to gas mixer and secondary air is fed into the bleacher.

(b) Ammonia Combustion

Ammonia and air mixture flows downwards in the converter. A distribution system allows nonhomogeneous flow over the surface of the platinum-rhodium gauzes catalyst, which are set on stainless steel supports.

The temperature of nitrous gases, nitrogen and oxygen resulting from ammonia combustion is about 850°C and its heat energy is recovered at several heat exchangers and steam boiler.

(c) Absorption and Bleaching

After cooled down by cooling water in the water condenser, the weak acid is condensed and fed into the absorber, the gas stream passes through the separator, is mixed with the secondary air and is compressed.

Heat exchanger recovers the heat of compression in warming up the tail gas stream. Then, the gas passes through the condenser cooled by water from absorber. The gas stream together with the acid condensate are fed into absorber, equipped with perforated trays and cooling coils. Part of these are fed by chilled water from ammonia evaporator. Process water is fed at the top of the absorber and the acid at design concentration is extracted from the bottom.

The product acid from absorber is fed to the bleacher of tray tower. The bleaching is completed by stripping with secondary air, which is pre-cooled in heat exchanger by condensate from the steam turbine.

The air from the bleacher, containing nitrous gases, is mixed with the main stream at inlet of the gas compressor.

The product nitric acid has concentration of 60% as HNO_3 and is sent to storage tanks and nitrophosphate plant.

(3) Product Specification

The plant is to produce a 534 TPD of nitric acid product (as 100% HNO_3 and in concentration of 60% of HNO_3 aqueous solution) under normal operating conditions.

The specification of such products are as follows:

Nitric Acid;

-Daily Production	534 TPD
-Analysis	
- HNO_3	60.0 %
- HNO_2	100.0 ppm
-Condition	
-Temperature	30°C
-Pressure	1.0 ata

(4) Raw Material, Utility, Chemicals and Catalyst Consumption

	<u>Production and Consumption</u>		
	<u>Unit Product</u>	<u>Hourly</u>	<u>Daily</u>
Production;			
-Nitric Acid, Ton	1.000	22.25	534.0
Consumption;			
-Ammonia, Ton	0.280	6.23	149.5
-Electric Power, kWh	11.000	244.75	5,874.0
-Boiler Feed Water, Ton	0.900	20.03	480.6
-Cooling Water, Ton	120.000	2,670.00	64,080.0
-Steam (Export), Ton	0.380	8.46	202.9
-Platinum Catalyst*, g	0.100	2.23	53.4

* The consumption of platinum catalysts is equivalent to USD 1.50/Ton of nitric acid on the date of base project cost estimate.

2-3 Nitrophosphate Plant

(1) Introduction

The nitrophosphate plant has a 551 TPD production capacity by using phosphate rock, nitric acid, ammonia and carbon dioxide as major raw materials.

In the plant, phosphate rock is decomposed by nitric acid and by deep cooling, calcium nitrate crystal are separated to remove calcium content from nitrophosphate fertilizer for increasing water solubility of P_2O_5 in final product. Separated calcium nitrate is then converted into ammonium nitrate and calcium carbonate and a portion of ammonium nitrate is incorporated as nitrogen source into nitrophosphate (NP) and the rest of ammonium nitrate is granulated by mixing with calcium carbonate to produce calcium ammonium nitrate fertilizer (CAN) in the calcium ammonium nitrate plant. Instead of CAN, ammonium nitrate is also produced in the plant, if required.

The product nitrophosphate and calcium ammonium nitrate are sent to bagging plant directly or indirectly through bulk product storage. The bagged product is shipped directly or indirectly through bagged product storage.

Surplus calcium carbonate will be sold as liming material or discarded as harmless inert materials in pond.

The process plant consists of three major sections:

- Wet Section
- Dry Section
- Calcium Nitrate Conversion Section

The product grade of NP is (20.8-20.8-0.0) but according to the market demand NPK grades such as (26.0-13.0-0.0) and (15.4-15.4-15.4) are also produced at the plant by adjusting raw material and process conditions. The raw material phosphate rock will be recovered at the proposed phosphate rock concentration plant at Sierra Grande, Argentine and its specification is shown in Table AV-8-1.

(2) Process Description

The typical stoichiometric reactions of nitrophosphate production is as follows:

Decomposition;

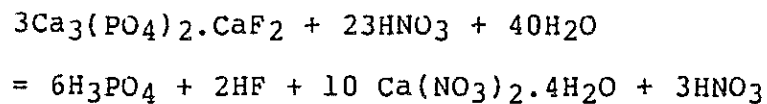

NP Production;

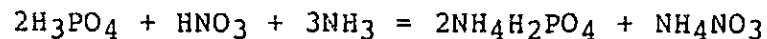

Calcium Nitrate Conversion;

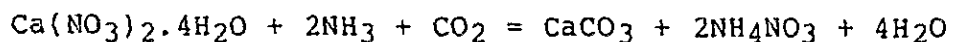

(a) Wet Section

The wet section consists of digestion, crystallization, calcium nitrate filtration and neutralization part.

Table AV-8-1 ANALYSIS OF PHOSPHATE ROCK EXTRACTED FROM IRON ORE CONCENTRATION
NON-MAGNETIC TAILS OF HIPASAM, SIERRA GRANDE, ARGENTINE

(1) CHEMICAL ANALYSIS

As Element	Weight Percent	As Oxide	Weight Percent	Equivalency for 100g Sample
P	15.56%	P ₂ O ₅	35.65%	(-) 1.507
C (Carbonate)	0.09	CO ₂	0.33	(-) 0.015
F	1.50	F	1.50	(-) 0.079
Cl	0.01	Cl	0.01	(-) 0.0005
OH	-	OH	(3.88)	(-) (0.2285)
S (Total)	-	S and Oxides	-	(-) -
S (Sulfide)	0.48	S	0.48	(-) 0.030
S (Sulfate)	-	SO ₃	-	(-) -
Si	1.98	SiO ₂	4.24	(-) 0.141
Fe (Total)	5.80	Fe Oxides	7.67	(+) 0.233
Fe (II)	4.36	FeO	(5.81)	(+) (0.156)
Fe (III)	1.44	Fe ₂ O ₃	(2.06)	(+) (0.077)
Al	1.46	Al ₂ O ₃	2.06	(+) 0.162
Mn	-	MnO	-	(+) -
Ca	31.66	CaO	44.30	(+) 1.580
Mg	0.22	MgO	0.36	(+) 0.018
Na	0.15	Na ₂ O	0.20	(+) 0.006
K	0.07	K ₂ O	0.08	(+) 0.002
Others	-	Others	-	-
Free Moisture	0.14	Free Moisture	0.14	-
Organics	-	Organics	-	-
Ignition Loss	1.68	Ignition Loss	1.68	-
Total	65.95	Sub-total	102.58	(-) 2.001
		Adjustment for F	(-) 0.63	(+) 2.001
		Total	101.95	(+) 0.000

(2) PHYSICAL PROPERTY

Color	Gray
Size Distribution (Tyler Mesh and Millimeter)	
(+) 400 Mesh (0.0370 mm)	15.9%
(+) 468.4 (0.0316)	18.4
(+) 577.8 (0.0219)	36.1
(+) 993.3 (0.0149)	52.5
(+) 1,309.7 (0.0113)	64.5
(-) 1,309.7 (0.0113)	35.4
	100.0
Density	3.27
Bulk Density - Packed	1.67
- Loose	1.27
Angle of Reponse	43.0°
Free Moisture of Filter Cake, %	13.0
Specific Surface Area, cm ² /gr	2,770

(3) FERTILIZER PROPERTY

	Weight Percent	Solubility Percent
Total P ₂ O ₅	35.65%	100.0%
Nitric Acid Soluble P ₂ O ₅	35.60	99.9
Hydrochloric Acid Soluble P ₂ O ₅	35.11	98.5
Citric Acid Soluble P ₂ O ₅	7.96	22.3
Formic Acid Soluble P ₂ O ₅	5.69	16.0
Ammonium Citrate Soluble (AV) P ₂ O ₅ (Neutral)	0.00	0.0
Water Soluble P ₂ O ₅	0.00	0.0

Notes: - Sample tails (Fe=27.53%, P₂O₅=7.08%) were taken on October 6, 1983 at HIPASAM and concentration test and analysis were made at NIKKO Consulting and Engineering Co. Ltd., Japan in January, 1984. Recovery of P₂O₅ is 55.5%. Fertilizer property was determined at Nissan Chemical Industries, Ltd., Japan in March, 1984.
- Ignition loss is measured by heating at 900°C for 0.5 hours.
- Free moisture is measured by heating at 105°C for 5.0 hours.
- (OH) is estimated to keep balanced equivalency.

The phosphate rock feed enters the rock surge bin and flows, after weighing, to the digester where the rock is reacted with nitric acid in order to convert the insoluble phosphate into soluble form.

A small quantity of excess acid is used to maintain the optimum conditions during digestion and subsequent crystallization. A part of nitric acid is first used for washing calcium nitrate crystals and then enters as wash acid into the digester.

The following main reactions take place in the digestion tanks.

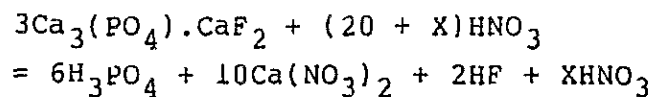

In order to decompose the phosphate rock with nitric acid, a series of digestion tanks is required and nitric acid concentration of 58-60% is applied for complete reaction.

During decomposition of the phosphate rock, the effluent gases containing HF, SiF₄, NO_x, CO₂ and water vapor are vented to the effluent treatment section to control the pollutant emissions to the atmosphere.

The digested solution from the crystallizer feed tank is fed to the crystallizers.

In the crystallizers, the digested solution is cooled to obtain the required quality of product by using a coolant prepared in the refrigeration system. The ratio of the contents of dicalcium phosphate and ammonium phosphate in the product is determined by the degree of calcium removal. Dicalcium phosphate is soluble in citrate solution, while ammonium phosphate is soluble both in citrate solution and in water.

Consequently, to achieve a high percentage of water soluble phosphate in the product, a large amount of calcium has to be removed in crystallization. The solubility of calcium nitrate in this solution decreases with decreasing temperature.

The suspension from the crystallizers contains uniform crystals of calcium nitrate tetrahydrate $[\text{Ca}(\text{NO}_3)_2 \cdot 4\text{H}_2\text{O}]$ which are separated from mother liquor at the rotating two stage vacuum filters. In the first filter, the mother liquor is separated from calcium nitrate crystals. Some of the mother liquor remains in the crystal cake, which is carried over to the second filter and are washed with nitric acid and water, which is recycled to the digester.

The filtrate liquor from the filter goes to the liquor tank, while crystals of calcium nitrate tetrahydrate are fed into the melting tank, from where it is sent to the calcium nitrate conversion section to recover nitrogen as ammonium nitrate.

The filtrate liquor from the liquor tank is sent to the neutralizer, in which the neutralization is carried out with gaseous ammonia.

The following main reactions take place in the neutralizing tank under controlled conditions.

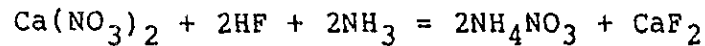
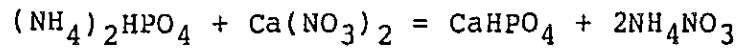
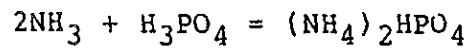
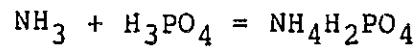
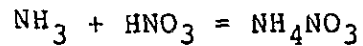

The neutralized liquor consists mainly of precipitated calcium phosphates, ammonium nitrate, monoammonium phosphate in a mixture.

In addition, reactions with impurities in the rock take place in this section. Therefore, in order to obtain favorable flow properties and to avoid the formation of insoluble phosphates, neutralization must be carried out under controlled conditions to adjust the type of phosphate rock used.

A portion of ammonium nitrate solution recycled from the calcium nitrate conversion is added to the liquor to obtain designed analysis of nitrogen and phosphate in the final product of nitrophosphate fertilizer.

(b) Dry Section

After neutralization, the liquor is sent to evaporator to reduce moisture.

The evaporator is designed to avoid scaling and precipitation of phosphates on the heating surface in the evaporators.

The concentrated liquor from the evaporator is fed to the pugmill type granulator, in which liquor is mixed with the recycle fines to form granular nitrophosphate product.

The recycle comprises the oversize granules separated in the oversize screen and crushed, the fines separated in the undersize screen and some amount of product size of granules separated in the undersize screen.

After granulation the product is dried in the rotary drum dryer where steam heated hot air is supplied. Then the dried granules are transported via belt conveyors and bucket elevator to the screens for classification. Apart from the recycle portion, the remaining granules for product size are sent to the cooler.

The off gas of the dryer is vented to the atmosphere by the dryer exhaust fan after dust collecting in the cyclones.

The product granules are cooled by air in the fluidized cooler. Then they are conditioned in coating drum with coating agent and oil to assure product with satisfactory storing property.

(c) Calcium Nitrate Conversion Section

The molten calcium nitrate from melting tank is transferred into the conversion reactor. Ammonia and

carbon dioxide are absorbed in ammonium nitrate solution in the absorption tower and the absorbed liquor of ammonium carbonate is fed to the conversion reactor through the tower liquor cooler.

In the reactor the conversion of calcium nitrate into ammonium nitrate and calcium carbonate takes place by the following reaction;

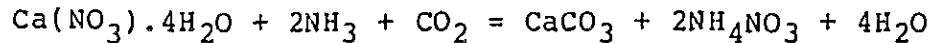

Ammonium nitrate solution with suspension of calcium carbonate overflows to the tank and is filtrated at the filter and the calcium carbonate cake is washed with water, and sent to the calcium ammonium nitrate plant.

On the other hand, the filtrate ammonium nitrate solution is further filtered in the polishing filter to remove impurities in ammonium nitrate solution and then fed to the pH control tank in which excess ammonia in the solution is neutralized with nitric acid to avoid loss of ammonia.

The dilute ammonium nitrate solution is concentrated at the evaporator and sent to the nitrophosphate granulator and calcium ammonium nitrate plant.

(3) Product Specification

The plant is to produce a 551 TPD of nitrophosphate fertilizer in bulk, a 291.9 TPD of ammonium nitrate solution and a 217.6 TPD of calcium carbonate under normal operating conditions.

The specification of such products are as follows:

Nitrophosphate (NP);

-Daily Production	551 TPD
-Analysis	
-Total Nitrogen	20.8 %
-Ammoniacal Nitrogen	11.4
-Nitrate Nitrogen	9.4
-Total P ₂ O ₅	21.1
-Available P ₂ O ₅	20.8
-Water Soluble P ₂ O ₅	15.8
-Free Moisture	0.6
-Condition	
-Temperature	40°C
-Pressure	1.0 ata
-Size Distribution	
(+) 4.0	3.0%
(-) 4.0, (+) 1.0	97.0
(-) 1.0	3.0
-Bulk Density	0.97
-Angel of Repose	32°
-Crushing Hardness (2.0 mm)	4.5 kg

Ammonium Nitrate Solution;

-Daily Production, Dry	291.9 TPD
-Analysis, Dry Weight Basis	
-Total Nitrogen	35.0%
-Ammoniacal Nitrogen	17.5
-Nitrate Nitrogen	17.5
-Moisture	8.0
-Condition	
-Temperature	120.0°C
-Pressure	1.0 ata

Calcium Carbonate;

-Daily Production, Dry	217.6 TPD
-Analysis,	
-CaCO ₃	85.7%
-Moisture	15.0
-Conditions	
-Temperature	80.0°C
-Pressure	1.0 ata
-Size Distribution	
(-) 0.05 mm	80 %

(4) Raw Material, Utility, Chemicals and Catalyst Consumption

	<u>Production and Consumption</u>		
	<u>Unit Product</u>	<u>Hourly</u>	<u>Daily</u>
Production;			
-Nitrophosphate, Ton, Bulk	1.000	22.96	551.1
-Ammonium Nitrate Melt, Ton	0.635	14.58	349.9
-Calcium Carbonate, Dry, Ton	0.395	9.07	217.7
Consumption;			
-Liquid Ammonia, Ton	0.275	6.31	151.5
-Nitric Acid, Ton	0.960	22.04	529.0
-Urea, Ton	0.004	0.09	2.3
-Phosphate Rock, (P ₂ O ₅ 35.65%), Ton	0.599	13.75	330.0
-Carbon Dioxide, Ton	0.204	4.68	112.4
-Silica, Ton	0.004	0.09	2.4
-Coating Oil, Ton	0.0004	0.01	0.2
-Electric Power, kWh	119.0	2,732.24	65,580.9
-Cooling Water, Ton	98.0	2,250.08	54,007.8
-Steam, Ton	1.070	24.57	589.6

2-4 Calcium Ammonium Nitrate Plant

(1) Introduction

The calcium ammonium nitrate plant has a 470.4 TPD production capacity by consuming the co-product of ammonium nitrate and calcium carbonate from the nitrophosphate plant.

Product calcium ammonium nitrate (CAN) contains 26% of nitrogen and is one of the major nitrogen fertilizers, especially in Europe. The product is safe from burning or explosion which was experienced for handling of ammonium nitrate in the past, and is considered as suitable nitrogen fertilizer for dry (not paddy) and/or cool climatic firm fields. The calcium is also effective for preventing the crop damages by salinity of soils.

The process is co-granulation of ammonium nitrate and calcium carbonate at pan granulator. Therefore the product quality of nitrogen content is adjustable according to the domestic market demands. An extreme case is to produce pure ammonium nitrogen contains 34.5% nitrogen which is also possible to produce in the plant.

The product is sent to bagging plant directly or indirectly through bulk storage. The bagged product is shipped directly or indirectly through bagged product storage.

The process plant consists concentration and drying section of raw materials and granulation section.

(2) Process Description

The raw materials of ammonium nitrate solution and wet calcium carbonate, both of them are the co-products at the nitrophosphate plant, are concentrated and dried at first.

Concentrated ammonium nitrate melt is sprayed through a nozzle onto the solid moving bed of dried calcium carbonate powder and recycle fines in the rotating pan type granulator.

The granulated material is fed to the rotating drum for polishing the surface of the product. The polished product is then sent to the cooler and screen separation to obtain uniform sized product. The crushed oversize and undersize material are fed back to the granulator for further processing.

The product size material is fed to the rotating drum and coated with coating agent for anti-caking treatment.

The product is transferred to the bulk storage or to the bagging plant.

(3) Product Specification

The plant is to produce a 470.4 TPD of calcium ammonium nitrate in bulk, under normal operating conditions.

The specification of the products is as follows:

Calcium Ammonium Nitrate (CAN);

-Daily Production	470.4 TPD
-Analysis	
-Total Nitrogen	26.0 %
-Ammonical Nitrogen	13.0
-Nitrate Nitrogen	13.0
-Free Moisture	0.4
-Conditions	
-Temperature	40.0°C
-Pressure	1.0 ata
-Size Distribution	
(+) 4.0 mm	3.0%
(-) 4.0, (+) 1.0	95.0
(-) 1.0	2.0
-Bulk Density	1.05
-Angle of Repose	32.0°
-Crushing Hardness (2.0 mm)	4.5 kg

5

(4) Raw Material, Utility, Chemicals and Catalyst Consumption

	<u>Production and Consumption</u>		
	<u>Unit Product</u>	<u>Hourly</u>	<u>Daily</u>
Production;			
-Calcium Ammonium Nitrate, Ton	1.000	19.60	470.4
Consumption;			
-Ammonium Nitrate, Dry, Ton	0.743	14.56	349.5
-Calcium Carbonate*, Dry, Ton	0.257	5.04	120.9
-Diatomaceous Earth, Ton	0.010	0.20	4.7
-Electric Power, kWh	31.0	607.60	14,582.4
-Cooling Water, Ton	4.00	78.40	1,881.6
-Steam, Ton	0.190	3.72	89.4

* Production of calcium carbonate at the nitrophosphate plant is 217.6 TPD, therefore daily 96.7 ton of calcium carbonate is surplus for sales or disposal.

2-5 Utility Plants

The major utility plants required for the nitrophosphate plant are designed to have following capacities:

	<u>Facility Capacity</u>	<u>Normal Demand</u>
Electric Power Receiving, kWh/h	20,000	17,863
Natural Gas Receiving, MMSCFD	20.0	11.14
Raw Water Treatment, TPD	10,000	7,210
Water Polisher, TPD	3,000	1,997
Steam Generation, TPH	20.0	15.0
Cooling Water Tower, TPH	9,000	7,796
Plant and Instrument Air, Nm ³ /h	3,000	1,500
Inert Gas Generation, Nm ³ /h	200	150
Waste Water Treatment, TPD	10,000	5,000
Emergency Power Generation, kWh/h	1,000	1,000

2-6 Storage and Material Handling Facility

The major facilities for raw materials, intermediates, and products receiving, storage, bagging and other material handlings are designed to have following capacity:

	<u>Facility Capacity</u>	<u>Normal Daily Requirements</u>
Storage Facilities;		
-Phosphate Rock, Ton	10,000	336.7
-Liquid Ammonia, Ton	3,000	303
-Nitric Acid, Ton	9,000	551.1
-Nitrophosphate and Calcium Ammonium Nitrate, Ton		
Bulk	100,000	1,022
Bagged	5,000	1,022
Bagging and Loading Facility;		
-Nitrophosphate and Calcium Ammonium Nitrate	280 TPH	43 TPH

2-7 Auxiliary Facilities

The major auxiliary facilities for the management of the operation, maintenance and accomodation at the phosphate fertilizer plant is designed to have following specifications;

	<u>Facility Specification</u>
Administration Building,	1,000m
Laboratory	300
Canteen	400
Garage and Gate House	200
Maintenance Shop	1,200
Storage House	1,200
Fine Fighting House	200
Others	-

3. Project Summary

The proposed nitrophosphate fertilizer plant project is to produce nitrophosphate and calcium ammonium nitrate as major products and calcium carbonate as by-product from phosphate rock and natural gas as major inputs.

3-1 Product and Production

The brief specification of the products and production is summarized as below:

<u>Product</u>	<u>Fertilizer Specification, %</u>			<u>Production, Ton</u>	
	<u>T-N</u>	<u>Av- P₂O₅</u>	<u>W- K₂O</u>	<u>Daily</u>	<u>Annual</u>
Nitrophosphate	20.8	20.8	0.0, Bagged	551.1	163,666
Calcium Ammonium Nitrate	26.0	0.0	0.0, Bagged	470.4	139,709
Calcium Carbonate	0.0	0.0	0.0, Bulk	96.7	28,720

The limiting factor for the production is the availability of phosphate rock which is recovered from the non-magnetic tails of HIPASAM, Sierra Grande, Río Negro. The total available phosphate rock is 100,000 TPY and the losses for transportation and handling of 2.0% is reduced from the production calculation.

3-2 Overall Consumption

The overall consumption of raw material, utility, catalyst and chemical for the proposed project is calculated for the financial analysis of the project which includes losses during storage, processing and bagging of the product, and also consumption for utility and auxiliary facilities.

In these calculation the by-product calcium carbonate is not credited for financial analysis.

	Production and Consumption		
	<u>Unit Product</u>	<u>Hourly</u>	<u>Daily</u>
Production;			
-Nitrophosphate, Bagged, Ton	0.5395	22.96	551.1
-Calcium Ammonium Nitrate, Bagged, Ton	0.4605	19.60	470.4
-Calcium Carbonate, <u>Bulk, Ton</u>	<u>(0.0947)</u>	<u>(4.03)</u>	<u>(96.7)</u>
Average (23.19-11.22-0.0), Bagged, Ton	1.000	42.56	1021.5
Consumption;			
-Natural Gas, MMBTU-LHV	9.8149	417.72	10,025.9
-Phosphate Rock (P ₂ O ₅ 35.65%), Ton	0.3296	12.47	336.7
-Catalysts and Chemicals*, USD-1963	1.3033	55.47	1,331.3
-Diatomaceous Earth*, Ton	0.0047	0.20	4.8
-Silica*, Ton	0.0021	0.09	2.1
-Coating Oil*, Ton	0.0002	0.01	0.20
-Raw Water, Ton	7.0583	300.40	7,210.1
-Electric Power, kWh	419.7133	17,863.00	428,737.1
-Fertilizer Bag, 50kg Net. Sheet	20.2000	859.71	20,634.3

* All cost, for these catalysts and chemicals in USD 1.424/Ton weighted average products of NP and CAN.

3-3 Overall Flow Block Diagram

The overall flow block diagram of the nitrophosphate plant showing process plant, utility and auxiliary facilities are illustrated in Figure AV-8-1.

3-4 General Plot Plan

The general plot plan of the nitrophosphate plant showing location of each major facilities are illustrated in Figure AV-8-2. The total site area required is 135,000 m² (450m x 300m)

3-5 Organization and Personnel

The overall organization and personnel for the nitrophosphate plant project is illustrated in Table AV-8-2. The total number of personnel in the organization is 440 under normal operating conditions.

3-6 Investment Cost Estimate

The estimate investment cost for the construction of the nitrophosphate plant is illustrated in Table AV-8-3. The project is assumed to be started with the engineering works on January 1, 1987 and located in Banía Blanca, Buenos Aires, Argentine.

3-7 Project Implementation Schedule

The overall implementation schedule for the nitrophosphate plant project is illustrated in Figure AV-8-3. It takes 30 months for the mechanical completion and 36 months for the commencement of commercial production from the date of contract award for the plant construction.

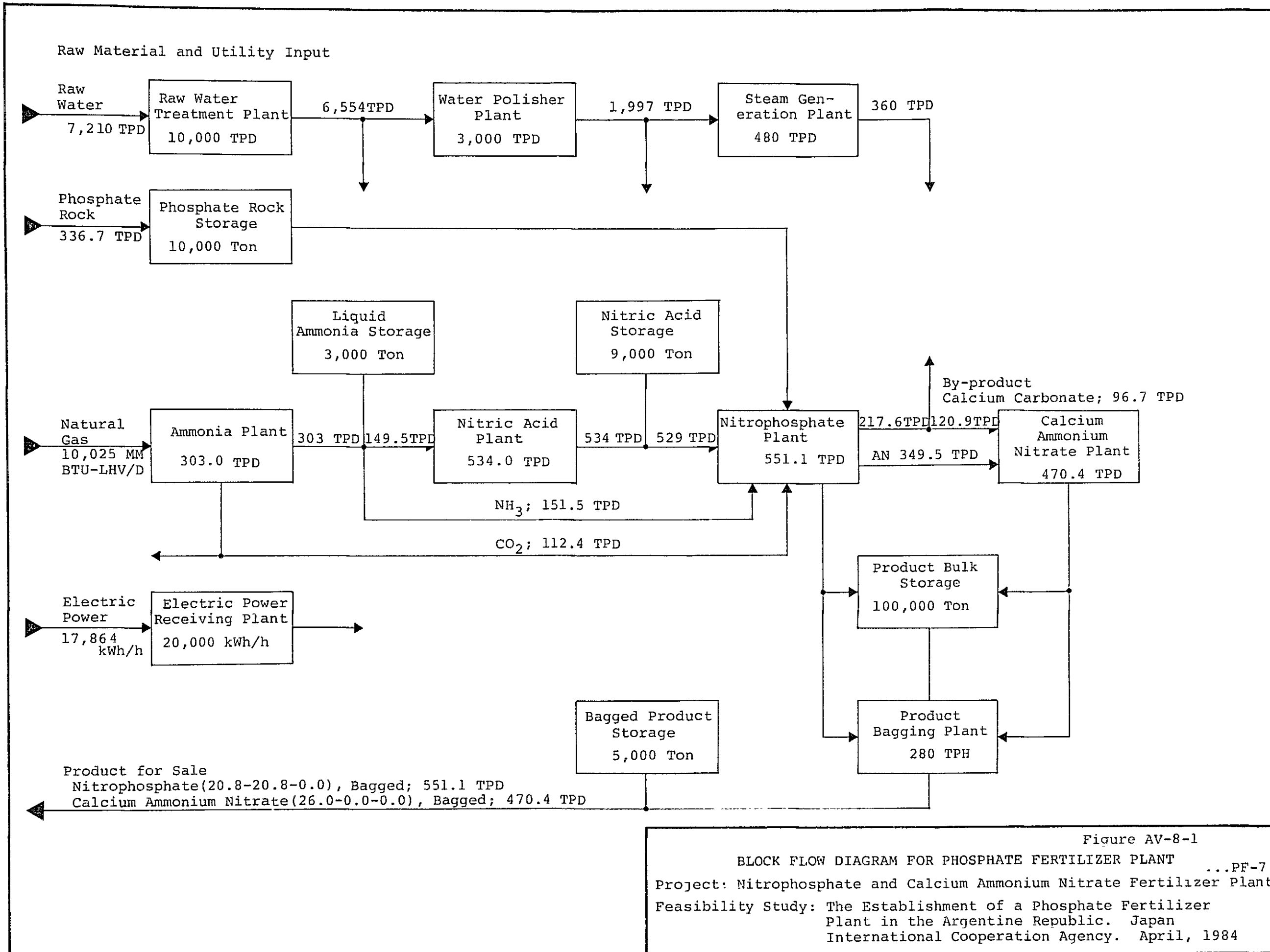

Figure AV-8-1
 BLOCK FLOW DIAGRAM FOR PHOSPHATE FERTILIZER PLANT ...PF-7
 Project: Nitrophosphate and Calcium Ammonium Nitrate Fertilizer Plant
 Feasibility Study: The Establishment of a Phosphate Fertilizer
 Plant in the Argentine Republic. Japan
 International Cooperation Agency. April, 1984

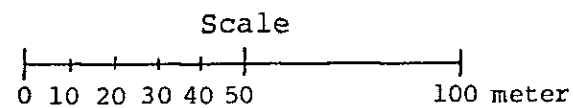
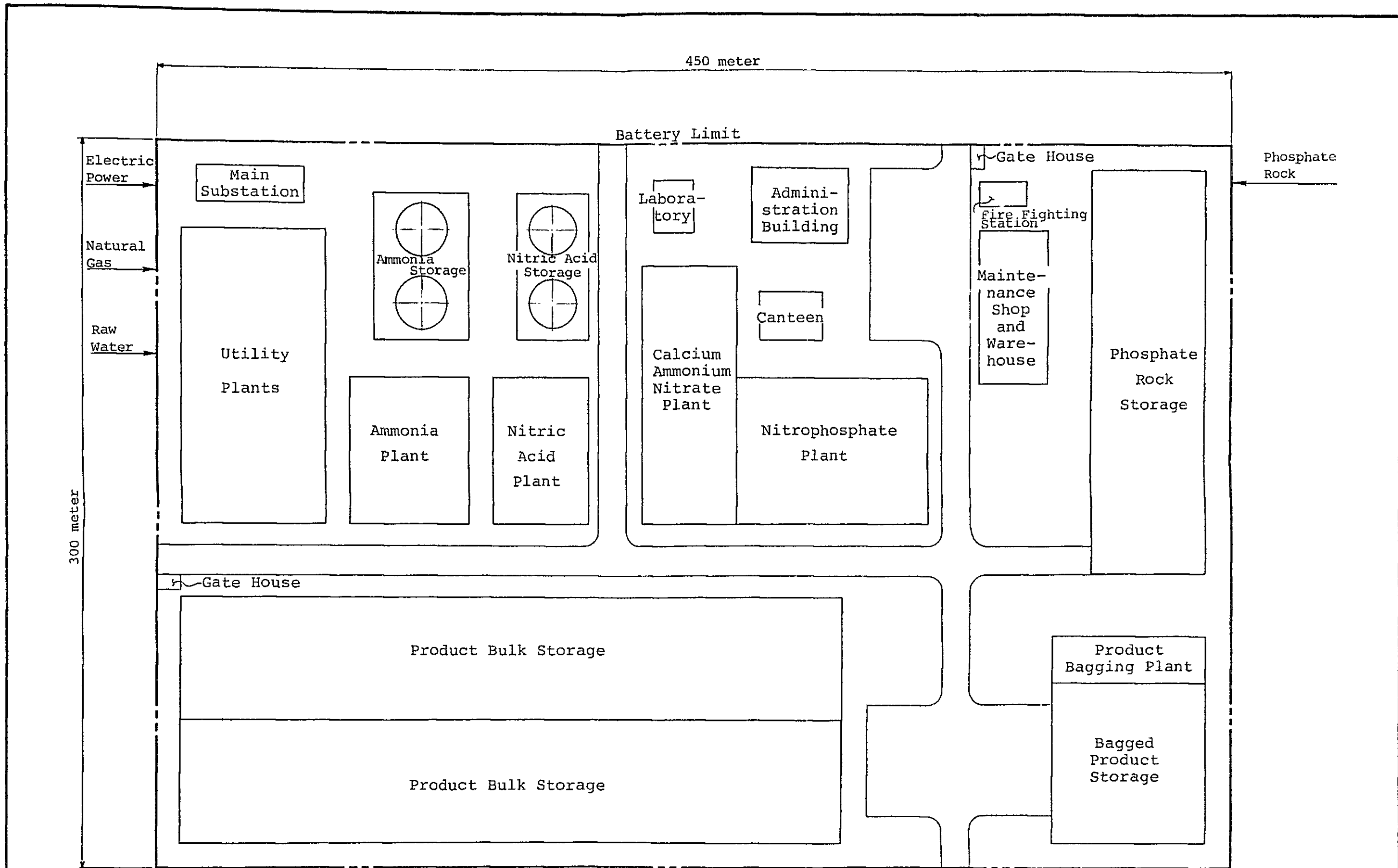

Figure AV-8-2
 GENERAL PLOT PLAN FOR PHOSPHATE FERTILIZER PLANT ... PF-7
 Project: Nitrophosphate and Calcium Ammonium Nitrate Fertilizer Plan
 Feasibility Study: The Establishment of a Phosphate Fertilizer Plant in the Argentine Republic. Japan International Cooperation Agency. April, 1984

Table AV-8-2 ORGANIZATION AND PERSONNEL REQUIREMENTS

Feasibility Study: On the Establishment of a Phosphate Fertilizer Plant in the Argentine Republic
 Project: Phosphate Fertilizer Plant, PF-7
 Product: Nitrophosphate and Calcium Ammonium Nitrate (NP/CAN), Bagged
 Capacity: 301,386 TPY of NP/CAN
 Location: Bahía Blanca, Buenos Aires, Argentine

Organization for the Project	Managing Director, Director	General Manager, Manager	Senior Engineer and Officer	Supervisor, Foreman, Officer	Operator, Worker, Secretary	Total
1. Head Office and Regional Sales Office - Buenos Aires	(6)	(2)	(3)	(4)	(4)	(19)
2. Factory Head Office and Plant Factory Complex - Bahía Blanca	(1)	(24)	(35)	(93)	(268)	(421)
2.1 Factory Director's Office	(1)	(1)	(2)	(4)	(4)	(12)
2.2 General Affairs Department	(0)	(4)	(9)	(9)	(16)	(38)
- Administration Section	0	1	1	1	2	5
- Personnel Section	0	0	1	1	2	4
- Financing/Accounting Section	0	1	1	1	2	5
- Housing and Welfare Section	0	0	1	1	2	4
- Security and Health Section	0	1	1	1	2	5
- Legal Section	0	0	1	1	3	4
- Purchase and Product Sales Section	0	1	3	3	4	11
2.3 Production Department	(0)	(4)	(5)	(16)	(68)	(93)
- Ammonia Plant	0	1	2	4	24	31
- Nitric Acid Plant	0	1	1	4	12	18
- Nitrophosphate Acid Plant	0	1	1	4	16	22
- Calcium Ammonium Nitrate Plant	0	1	1	4	16	22
2.4 Utility Department	(0)	(3)	(4)	(16)	(32)	(55)
- Water Treatment	0	1	1	4	8	14
- Cooling Water Tower	0	1	1	4	8	14
- Steam Generation	0	1	1	4	8	14
- Others	0	0	1	4	8	13
2.5 Maintenance and Inspection Department	(0)	(5)	(6)	(30)	(36)	(77)
- Maintenance Management	0	1	1	4	4	10
- Mechanical Section	0	1	1	8	16	26
- Electrical Section	0	1	1	8	8	18
- Instrumental Section	0	1	1	4	4	10
- Civil Construction Section	0	0	1	2	2	5
- Inventory Section	0	1	1	4	2	8
2.6 Product Handling Department	(0)	(3)	(4)	(8)	(92)	(107)
- Storage Management	0	1	1	2	8	12
- Bagging Section	0	1	1	2	40	44
- Loading Section	0	1	1	2	40	44
- Phosphate Rock Receiving	0	0	1	2	4	7
2.7 Technical and Development Department	(0)	(4)	(5)	(10)	(20)	(39)
- Production Management	0	1	1	2	2	6
- Development and Engineering Section	0	1	1	2	2	6
- Analytical Laboratory	0	1	1	2	12	16
- Training Section	0	1	1	2	2	6
- Product Sales Services	0	0	1	2	2	5
3. Total Personnel for the Project	7	26	38	97	272	440

Notes: 1) Additional contract laborers for product bagging and loading is assumed during peak shipping season.

2) During annual maintenance work for 35 days, additional maintenance supervisor and labor are contracted (Vendor specialist; 40, Inspector; 50, Laborer; 450, Total; 540 persons) whose costs are included in maintenance cost for financial analysis.

Figure AV-8-3 PROJECT IMPLEMENTATION SCHEDULE

Project: Phosphate Fertilizer Plant, PF-7
 Product: Nitrophosphate and Calcium Ammonium Nitrate Fertilizer (NP/CAN), Bagged
 Location: Bahia Blanca, Buenos Aires, Argentine
 Feasibility Study: On the Establishment of a Phosphate Fertilizer Plant in the Argentine Republic

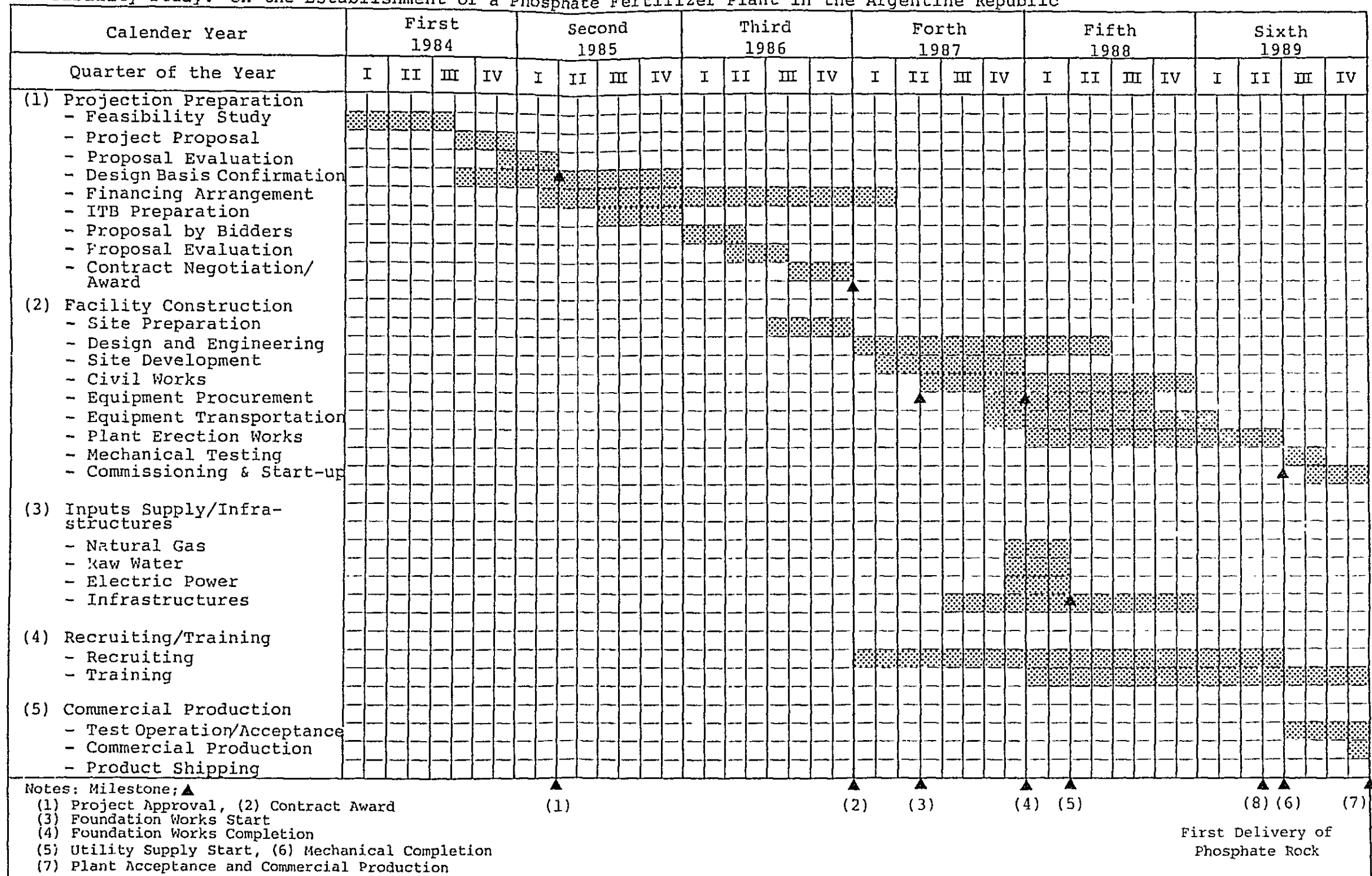

Supplement to Annex V-8

Nitrophosphate and Ammonium Nitrate Production

As described before, the proposed nitrophosphate plant can also produce ammonium nitrate instead of CAN, in accordance with requirements of the markets. Supplemented below are overall consumption figures and block flow diagram for this alternative production of ammonium nitrate by the proposed nitrophosphate plant.

	Production and Consumption		
	Unit Product	Hourly	Daily
Production;			
-Nitrophosphate, Bagged, Ton	0.6119	22.96	551.1
-Ammonium Nitrate, Bagged, Ton	0.3881	14.56	349.5
-Calcium Carbonate, <u>Bulk, Ton</u>	<u>(0.2417)</u>	<u>(9.07)</u>	<u>(217.6)</u>
Average (26.12-12.73-0.0), Bagged, Ton	1.000	37.52	900.6
Consumption;			
-Natural Gas, MMBTU-LHV	11.1333	417.72	10,025.9
-Phosphate Rock (P ₂ O ₅ 35.65%), Ton	0.3324	12.47	336.7
-Catalysts and Chemicals*, USD-1963	1.4784	55.47	1,331.3
-Diatomaceous Earth*, Ton	0.0053	0.20	4.8
-Silica*, Ton	0.0024	0.09	2.1
-Coating Oil*, Ton	0.0003	0.01	0.20
-Raw Water, Ton	8.0064	300.40	7,210.1
-Electric Power, kWh	476.09	17,863.00	428,737.1
-Fertilizer Bag, 50kg Net. Sheet	20.20	757.90	18,189.7

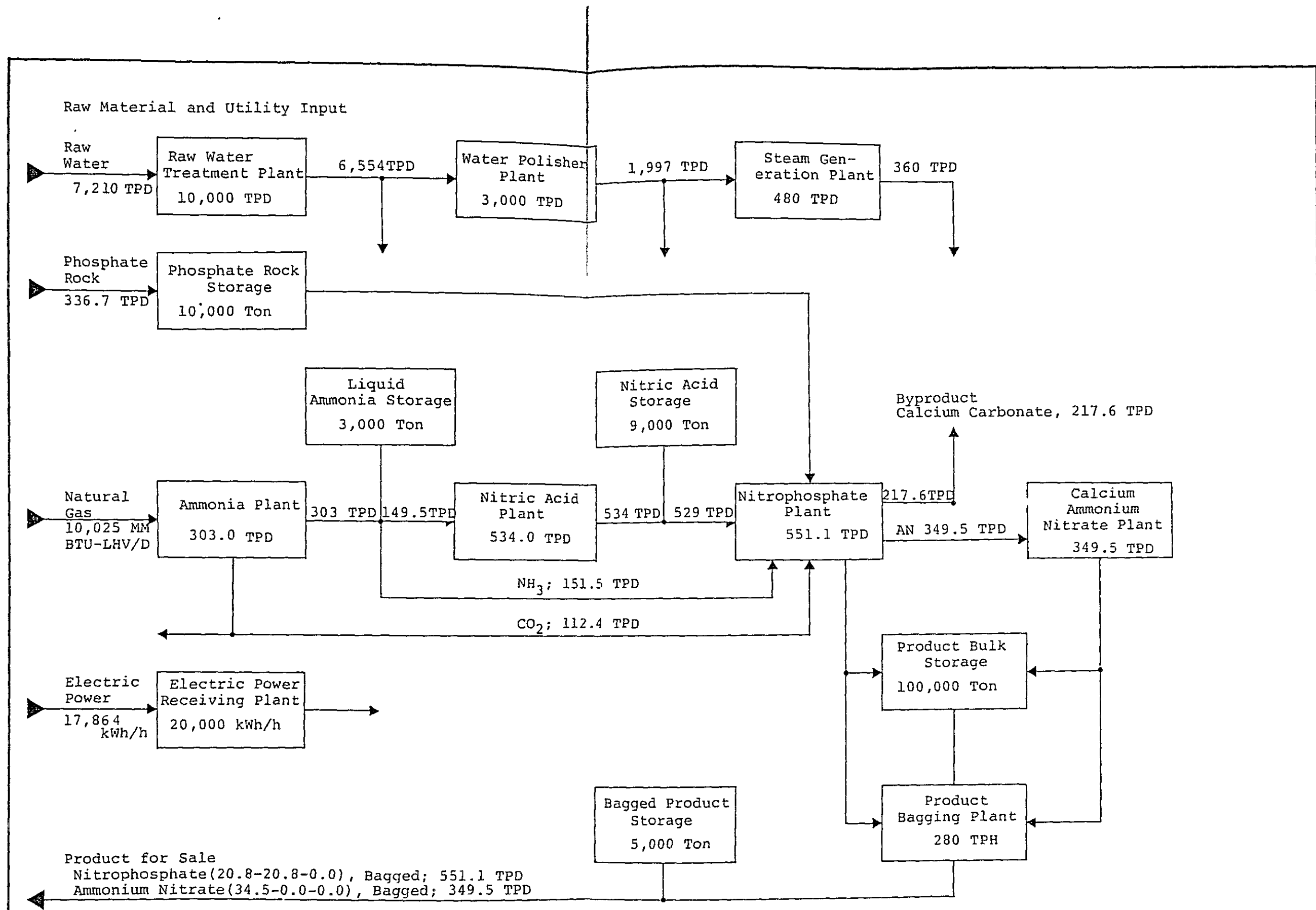

Figure AV-8-1(B)
 BLOCK FLOW DIAGRAM FOR PHOSPHATE FERTILIZER PLANT
 Project: Nitrophosphate and Ammonium Nitrate Fertilizer Plant...PF-7
 Feasibility Study: The Establishment of a Phosphate Fertilizer Plant in the Argentine Republic. Japan International Cooperation Agency. April, 1984

