

CHAPTER 7

Fig. 7-7	Access Railway Alignment
Fig. 7-8	Access Railway via Site No. 1 (Profile)
Fig. 7-9	Access Railway via Site No. 2 (Profile)
Fig. 7-10	Access Railway via Site No. 3 (Profile)
Fig. 7-11 } Fig. 7-21 }	Detail Plan and Profile of Access Railway via Site No. 3
Fig. 7-22	
Fig. 7-23 } Fig. 7-27 }	Cross Section of Access Railway via Site No. 3
Fig. 7-28	
Fig. 7-29	Kyangin - Sinde Railway Alignment
Fig. 7-30	Kyangin - Sinde Railway (Profile)
Fig. 7-31	Layout of Kyangin Station and Typical Way Station
Fig. 7-33	Signal Layout

PROJECT	IRRAWADDY-RIVER BRIDGE
SITE NO. 1, 2, 3	FIGURE NO. 7-7
SCALE V = 1:	H = 1:126 720

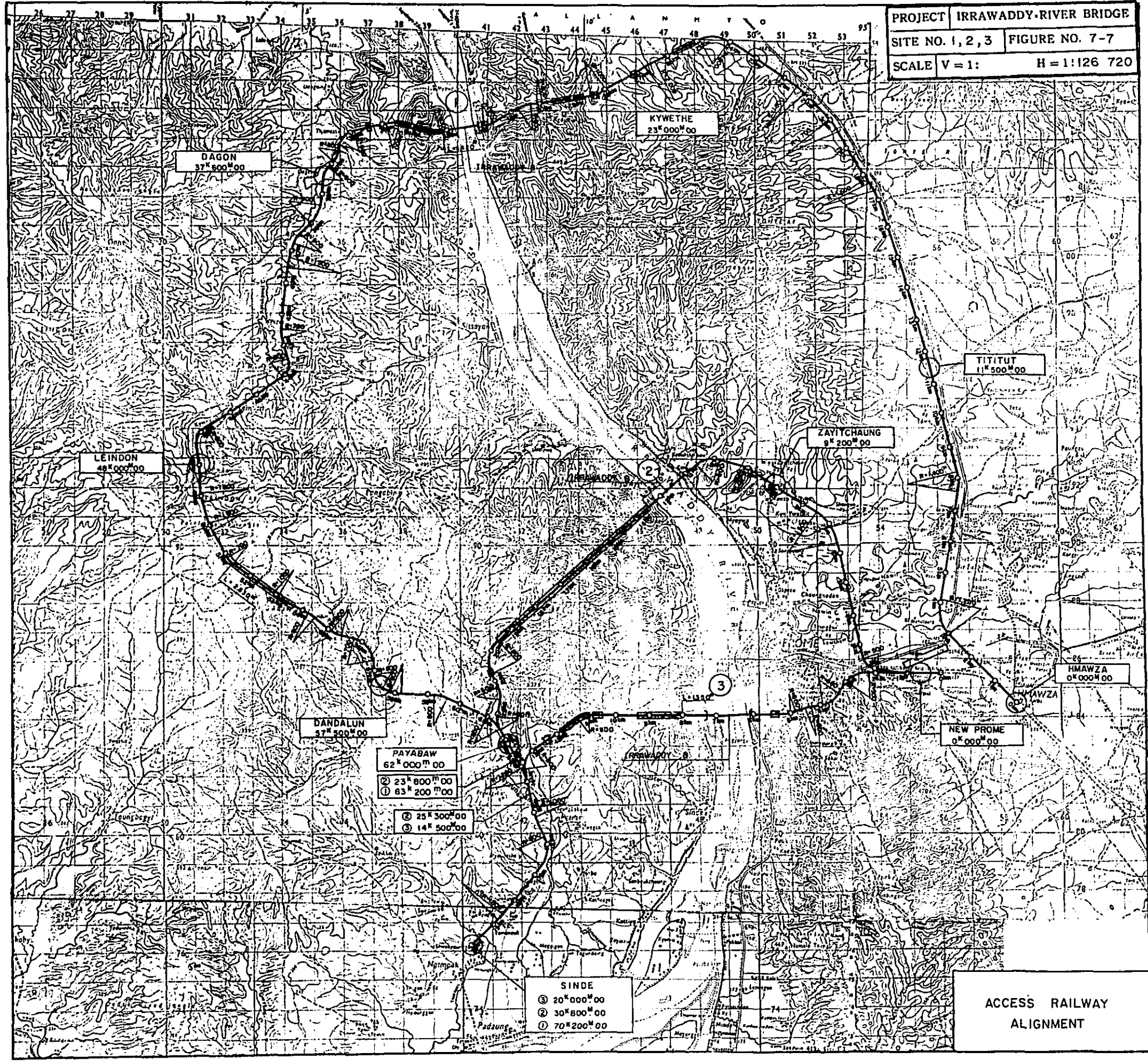

PAYABAW	62° 00' 00\"/>
②	23° 800' 00\"/>
①	63° 200' 00\"/>
②	25° 300' 00\"/>
③	14° 500' 00\"/>

SINDE	20° 000' 00\"/>
②	30° 800' 00\"/>
①	70° 200' 00\"/>

ACCESS RAILWAY  
ALIGNMENT

BURMA RAILWAY, HMAWZA

$0.000^m$

$3^k 720^m$   $B(Ct) 1 \times 10.0$   $L=10.0$

$5^k 880^m$   $B(Ct) 1 \times 15.0$   $L=15.0$

$6^k 550^m$   $Nawin B(Ctp) 4 \times 25.00$   $L=102.40$

$7^k 100^m$   $B(Ct) 1 \times 10.0$   $L=10.0$

$8^k 020^m$   $B(Ct) 1 \times 10.0$   $L=10.0$

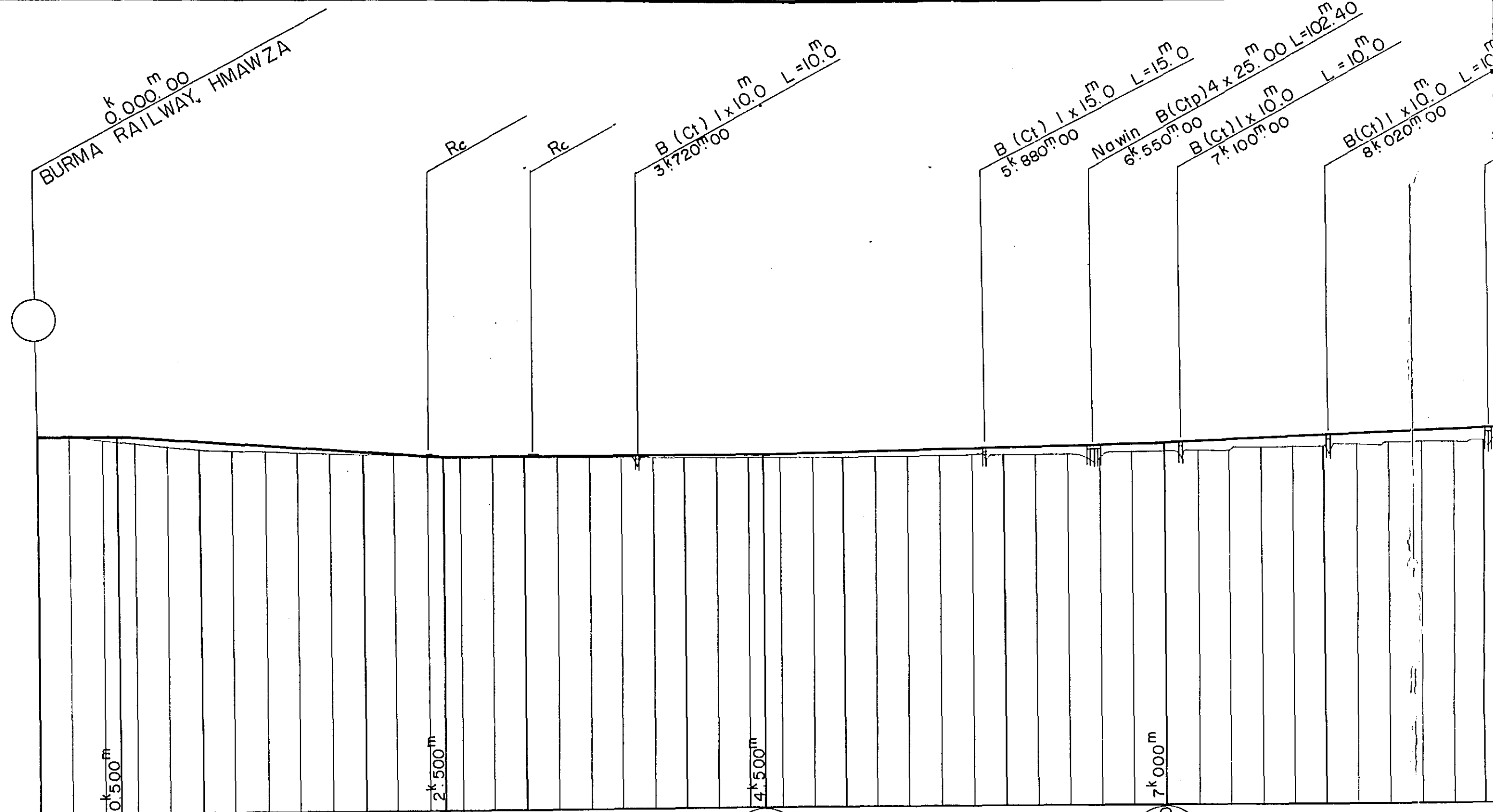

GRADE ‰
HEIGHT OF FORMATION M
KILOMETRAGE
CURVE

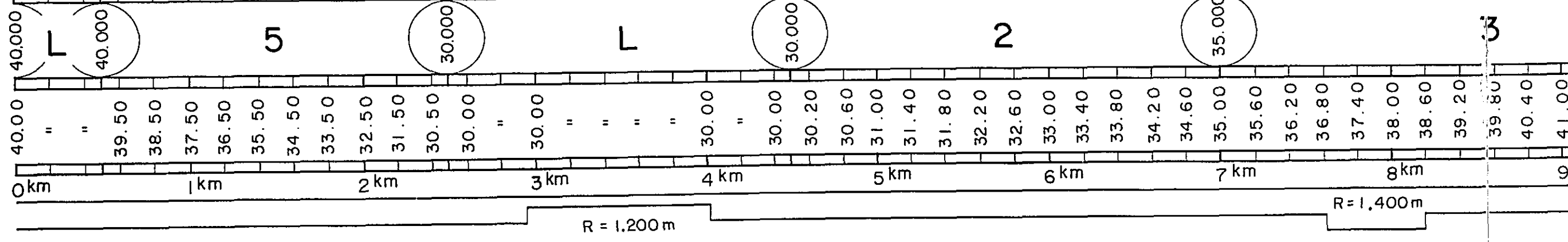





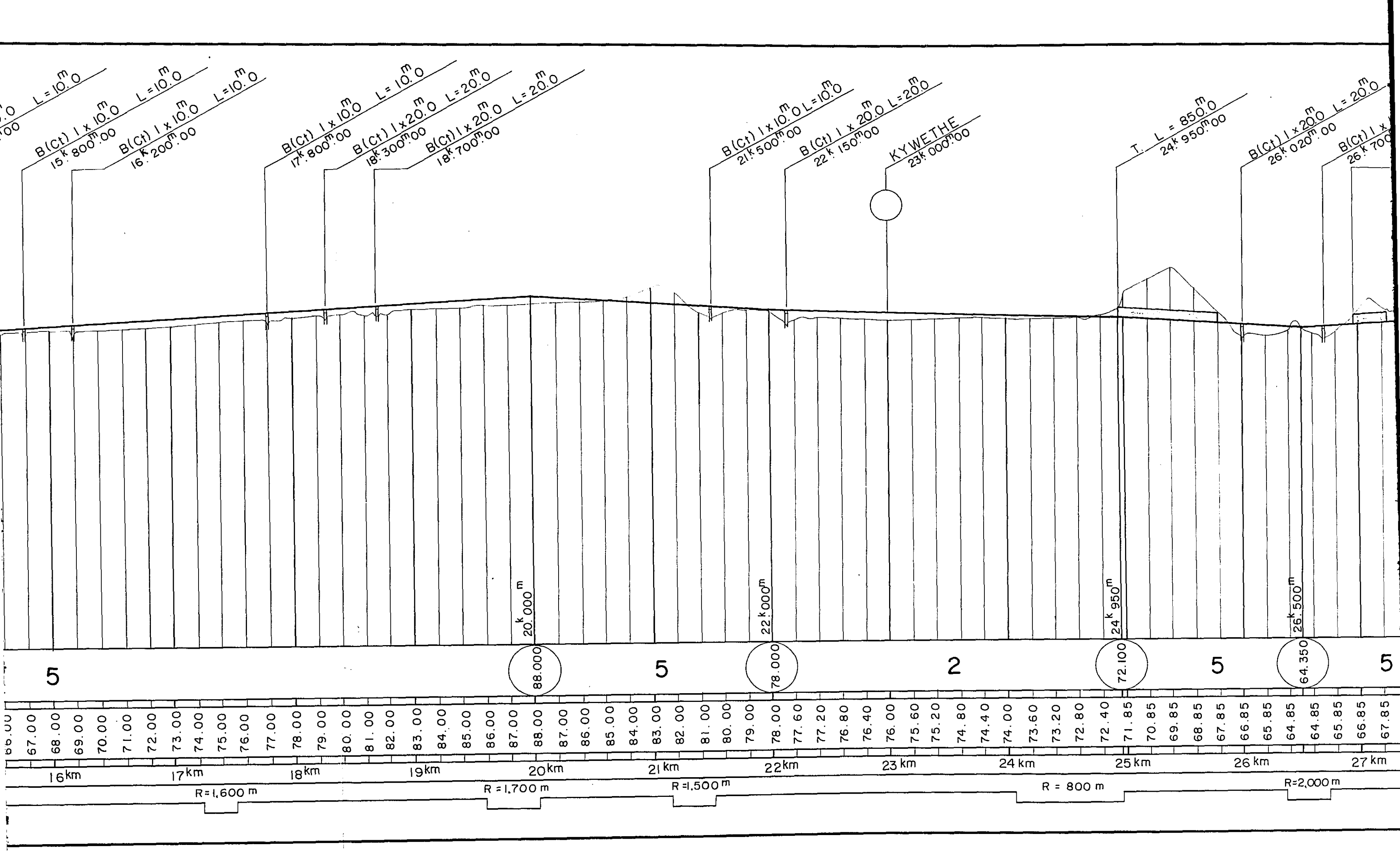

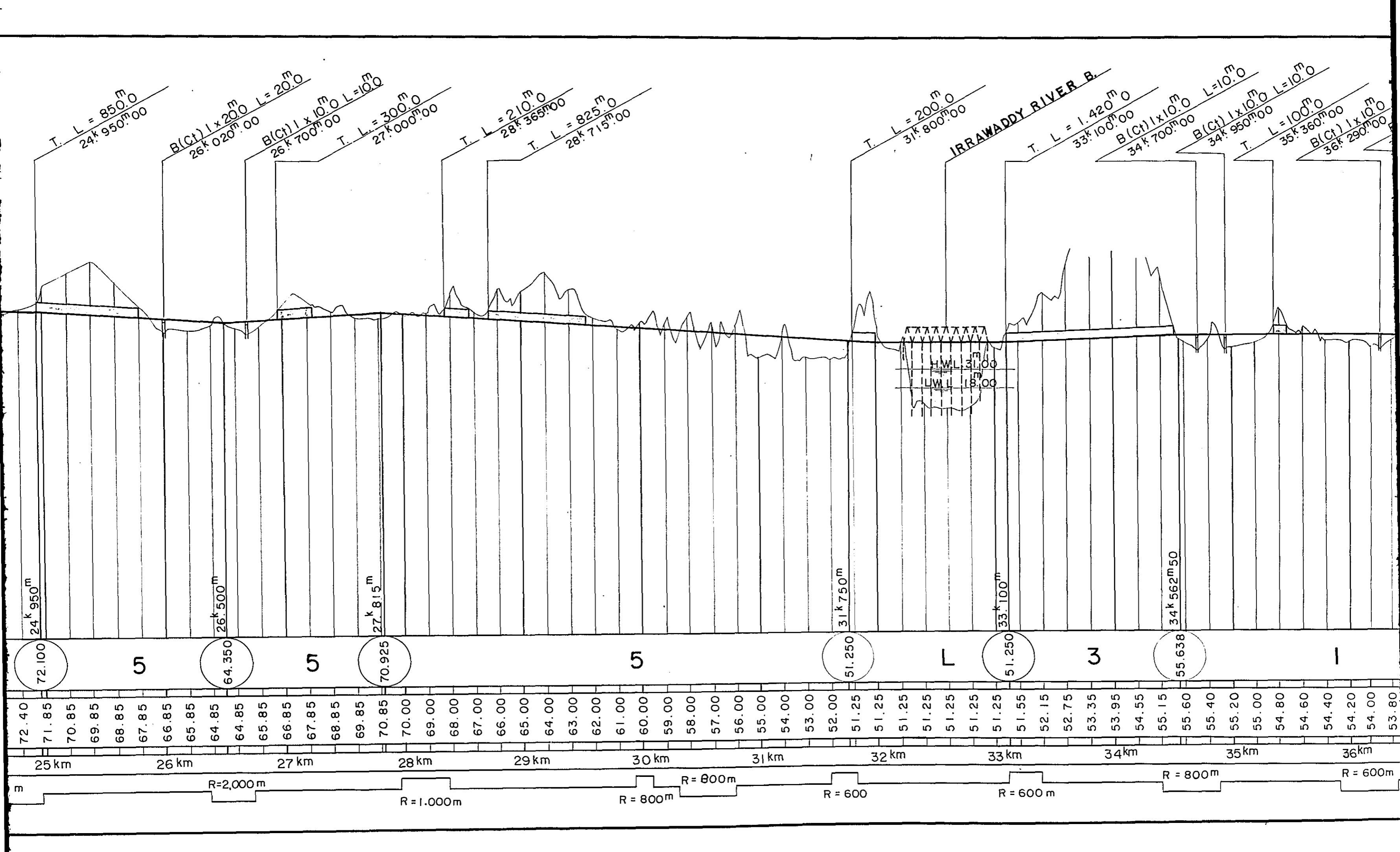

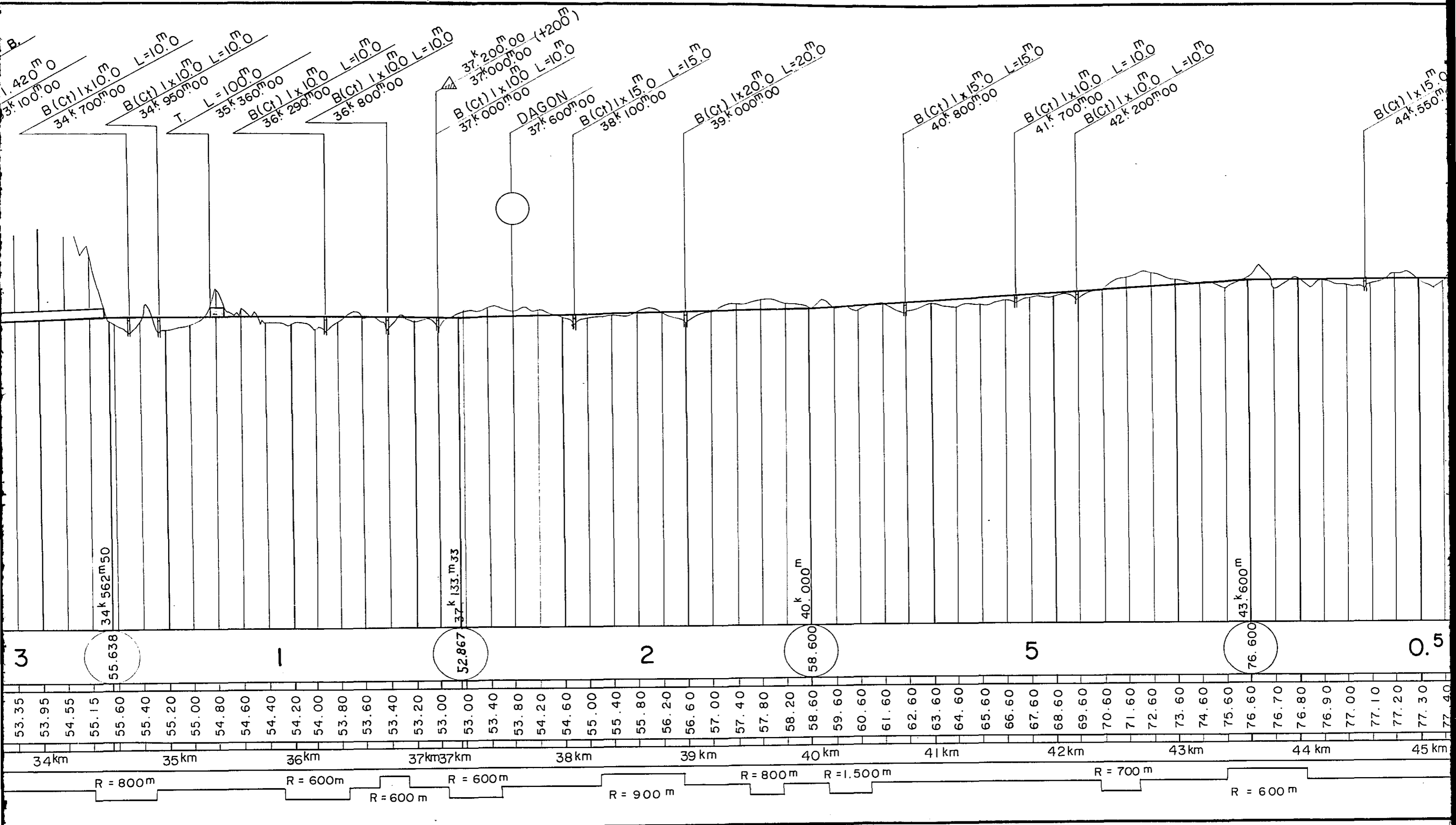



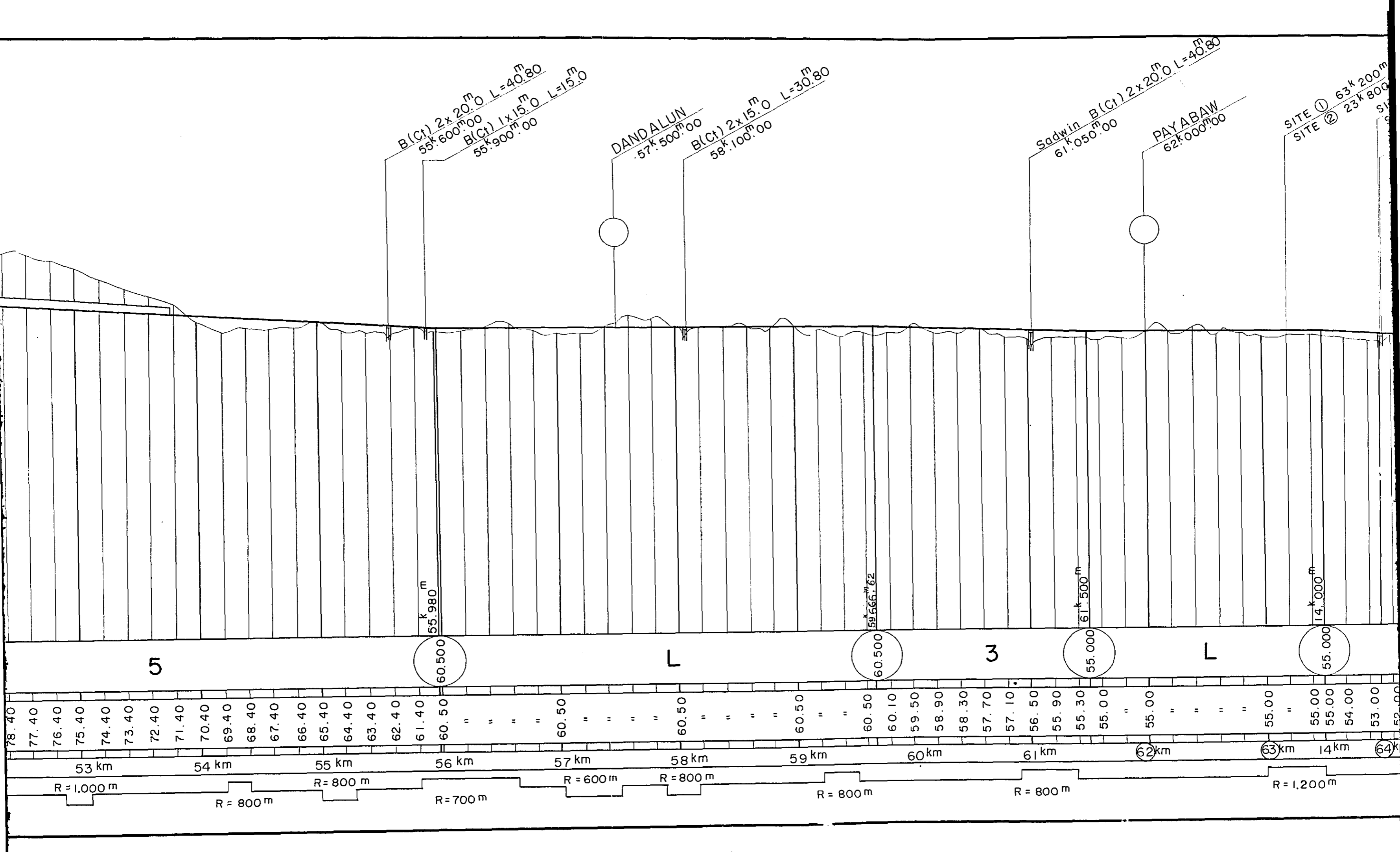

SITE ① 63k 200m 00  
 SITE ② 23k 800m 00  
 SITE ③ 25k 300m 00  
 14k 500m 00  
 B(Ct) 1 x 20.0 L=20.0  
 14k 530m 00

B(Ct) 1 x 15.0 L=15.0  
 16k 720m 00

B(Ct) 1 x 15.0 L=15.0  
 17k 835m 00

B(Ct) 4 x 10.0 L=42.40  
 18k 840m 00

B(Ct) 1 x 10.0 L=10.0  
 19k 200m 00

B(Ct) 1 x 15.0 L=15.0  
 19k 555m 00

SINDE  
 70k 200m 00 (Via Site 1)  
 20k 000m 00 (Via Site 3)

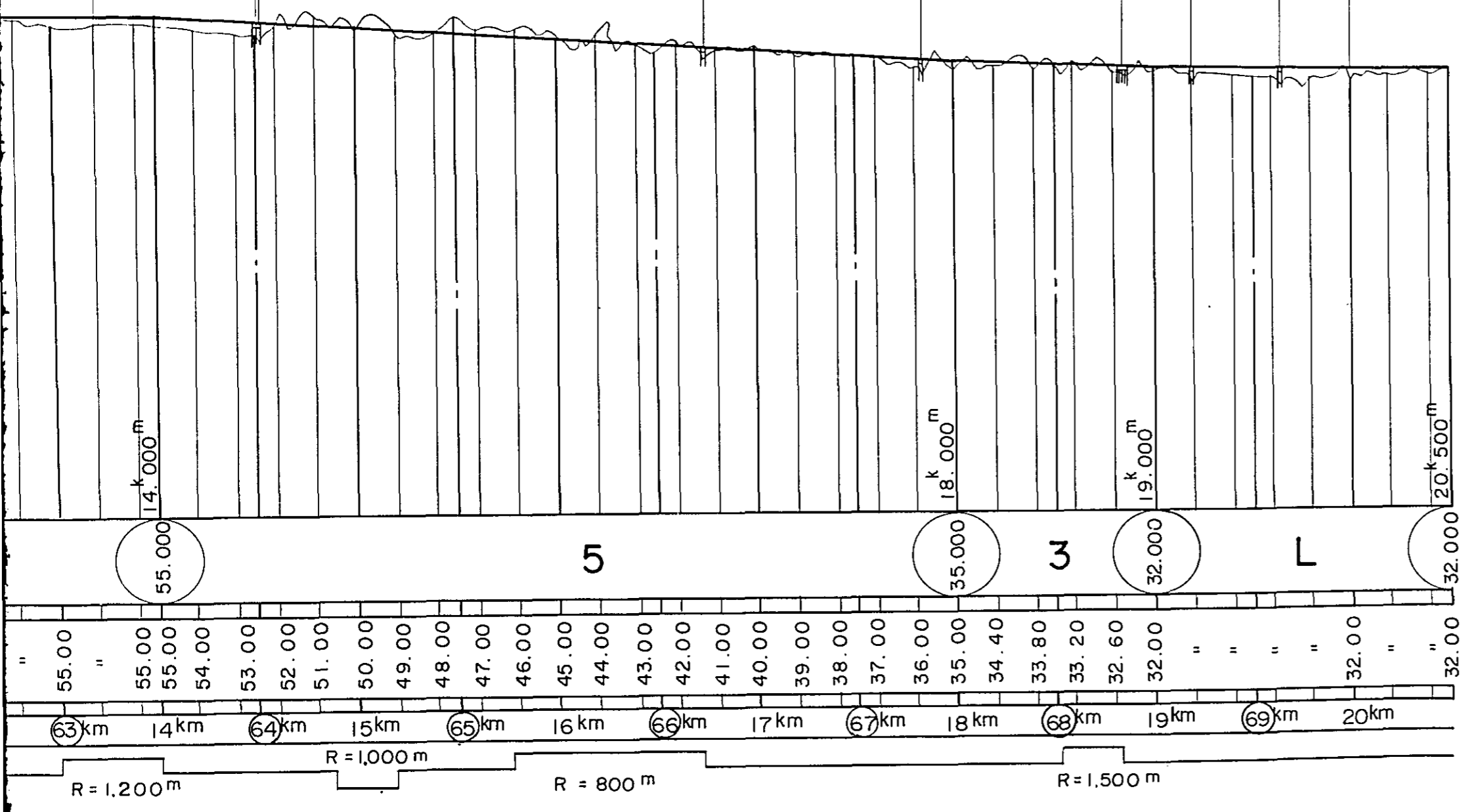

ACCESS RAILWAY  
 VIA SITE No.1  
 (PROFILE)

0+000.00 NEW PROME  
BURMA RAILWAY

$R_c$   
B(Ct) 1x10.00 L=10.00  
2k 470.00

B(Ct) 3x20.00 L=61.06  
3k 350.00

Nawin River  
4k 100.00

B(Ct) 4x25.00 L=102.40  
4k 770.00

B(Ct) 2x20.00 L=82.04  
5k 020.00

B(Ct) 2x20.00 L=40.08  
5k 280.00

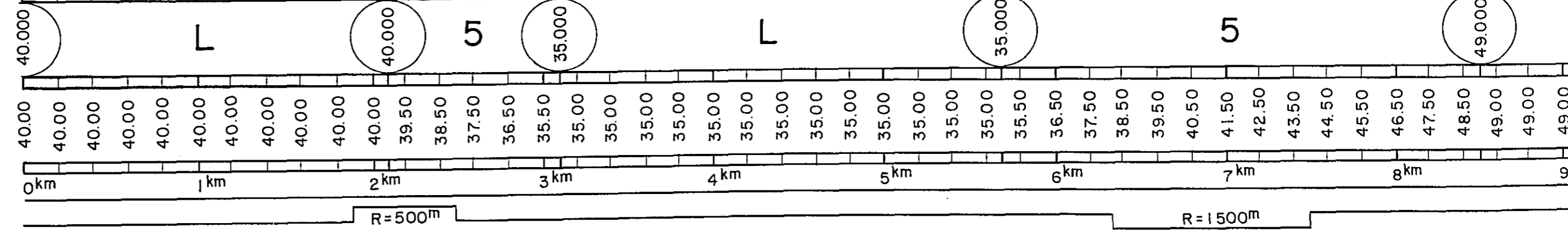
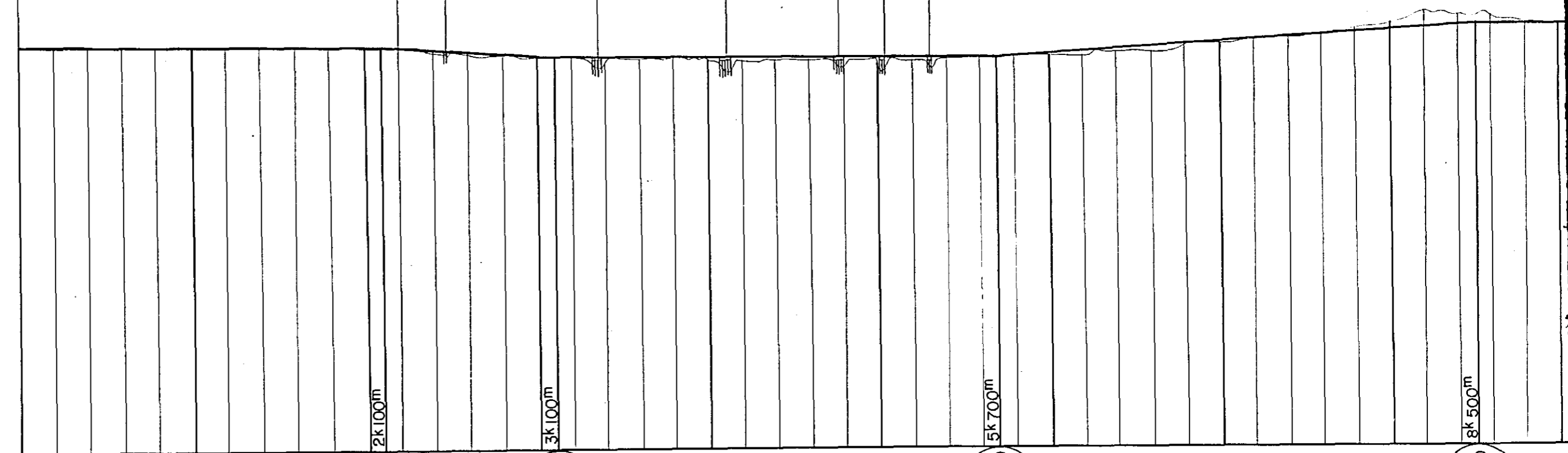
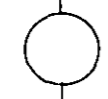

GRADE ‰
40.000
35.000
49.000

R=500m

R=1500m

49.000

40.000

35.000

35.000

40.000

8k 500m

5k 700m

3k 100m

2k 100m



10m8

ZAYITCHAUNG  
9k 200m00

B(Ct) 3x20m0  
10k 400m00 L=61m6

B(Ct) 1x20m0  
11k 420m00 L=20m0

IRRAWADDY RIVER B.  
T L=6 240m0  
13k 580m00

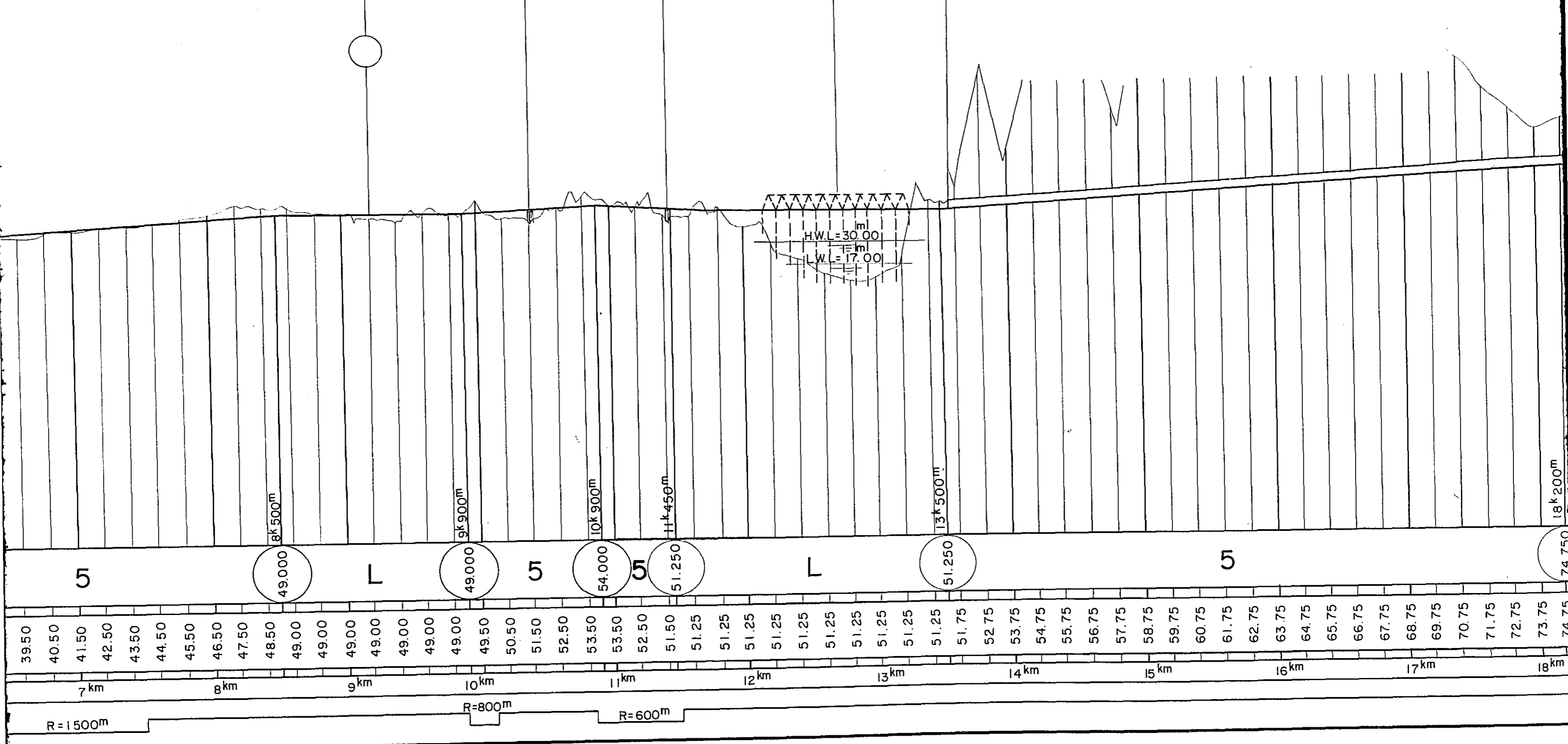

R=1500m

R=800m

R=600m

18k 200m

74 750

74 75

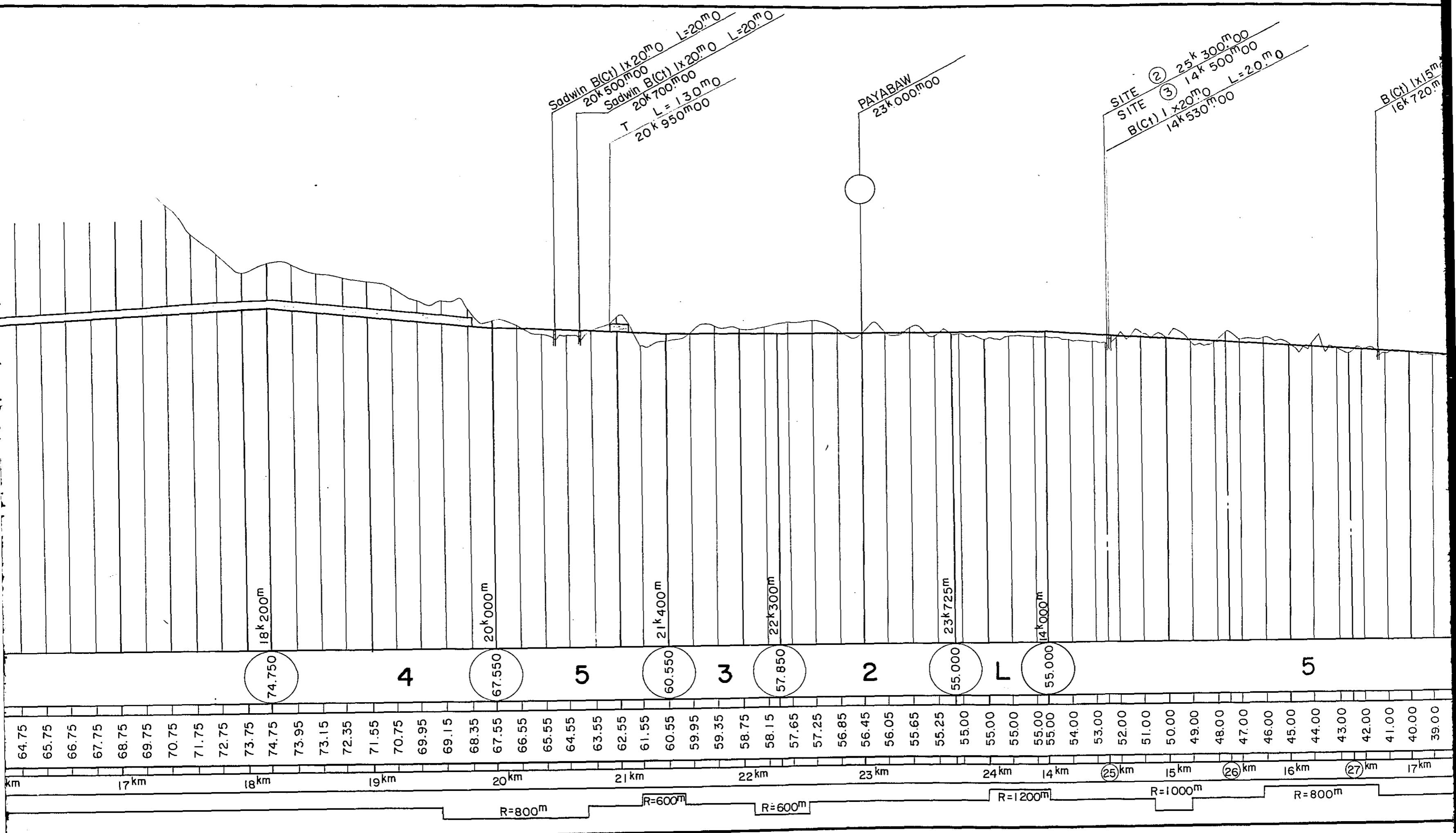

PROJECT	IRRAWADDY RIVER BRIDGE	
SITE NO.	2	FIGURE NO. 7-9
SCALE	V=1:2000	H=1:25,000

SITE ② 25k 300m00  
 SITE ③ 14k 500m00  
 B(Ct) 1x20m0 L=20m0  
 14k 530m00

B(Ct) 1x15m0 L=15m0  
 16k 720m00

B(Ct) 1x15m0 L=15m0  
 17k 835m00

B(Ct) 4x10m0 L=42m4  
 18k 840m00

B(Ct) 1x10m0 L=10m0  
 19k 200m00

B(Ct) 1x15m0 L=15m0  
 19k 555m00

SINDE  
 30k 800m00 (Via Site 2)  
 20k 000m00 (Via Site 3)

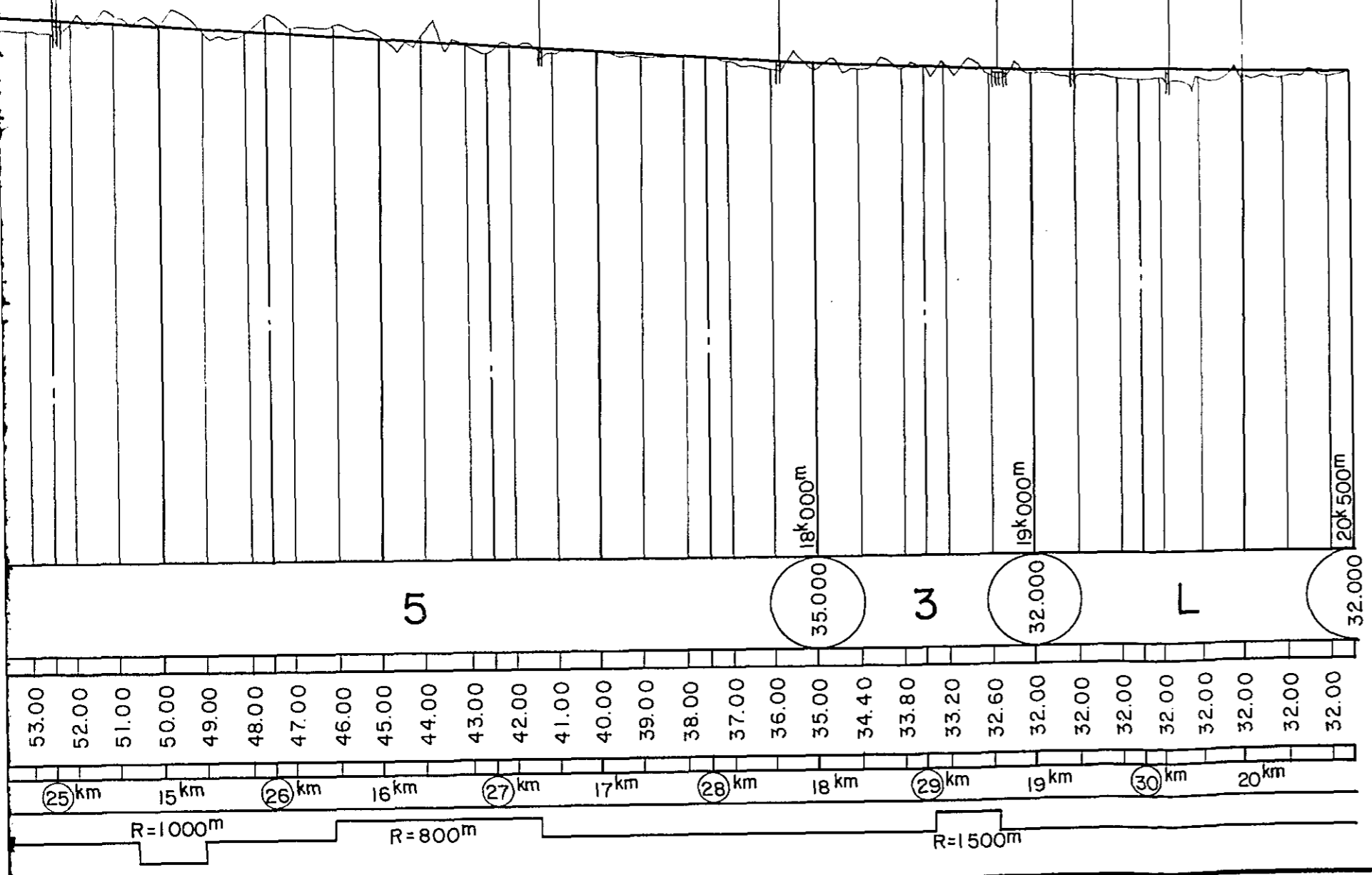

ACCESS RAILWAY  
 VIA SITE No.2  
 (PROFILE)

0k 000m00 NEW PROME  
BURMA RAILWAY

B (Cb) 1x 5.0  
2k 555m00

B (Ct) 1x15m0  
2k 865m00 L=15m0

B (Ct) 1x10m0  
3k 850m00 L=10m0

B (Ct) 1x10m0  
3k 985m00 L=10m0

T L=240m0  
5k 390m00

IRRAWADDY RIVER B.

B (Cb) 1x 5.0  
7k 400m00

T L=1.350m0  
7k 990m00

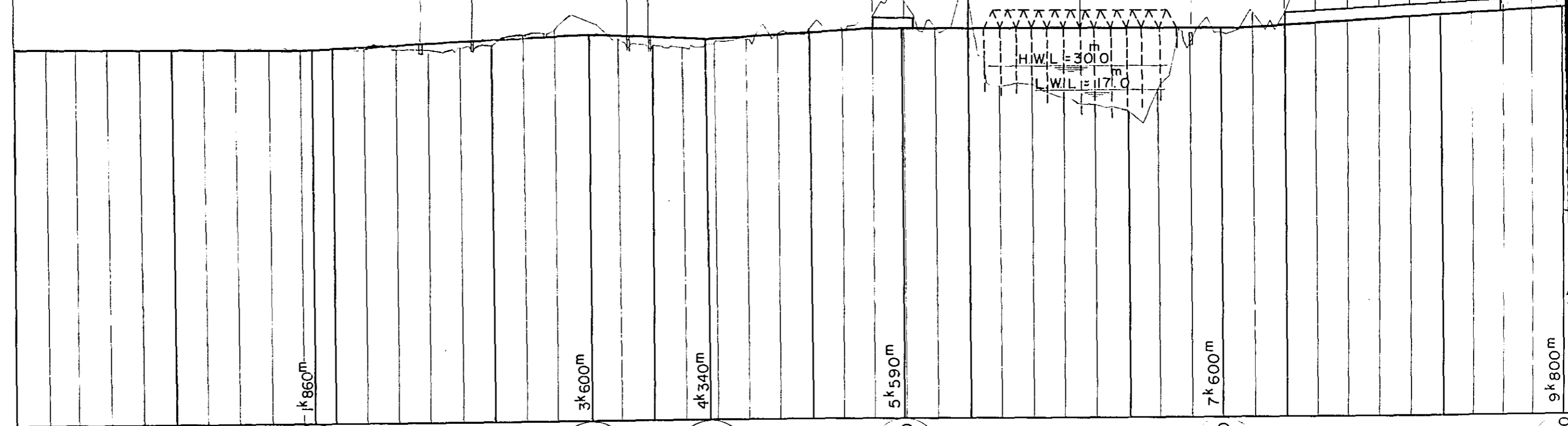
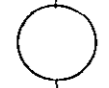

GRADE ‰
HEIGHT OF FORMATION M
KILOMETRAGE
CURVE

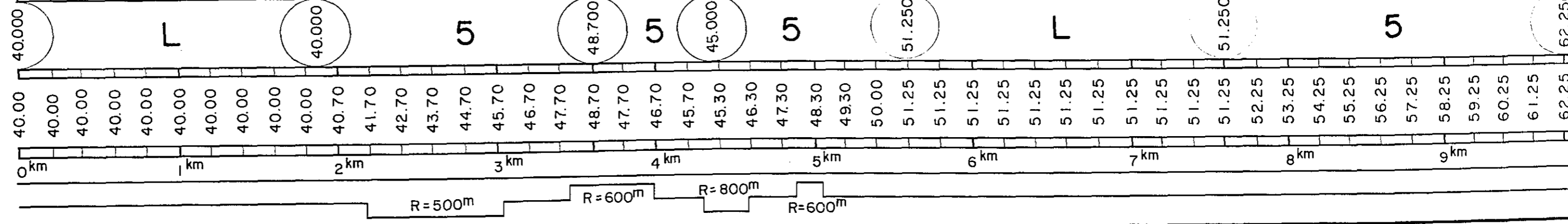

R=500m R=600m R=800m R=600m

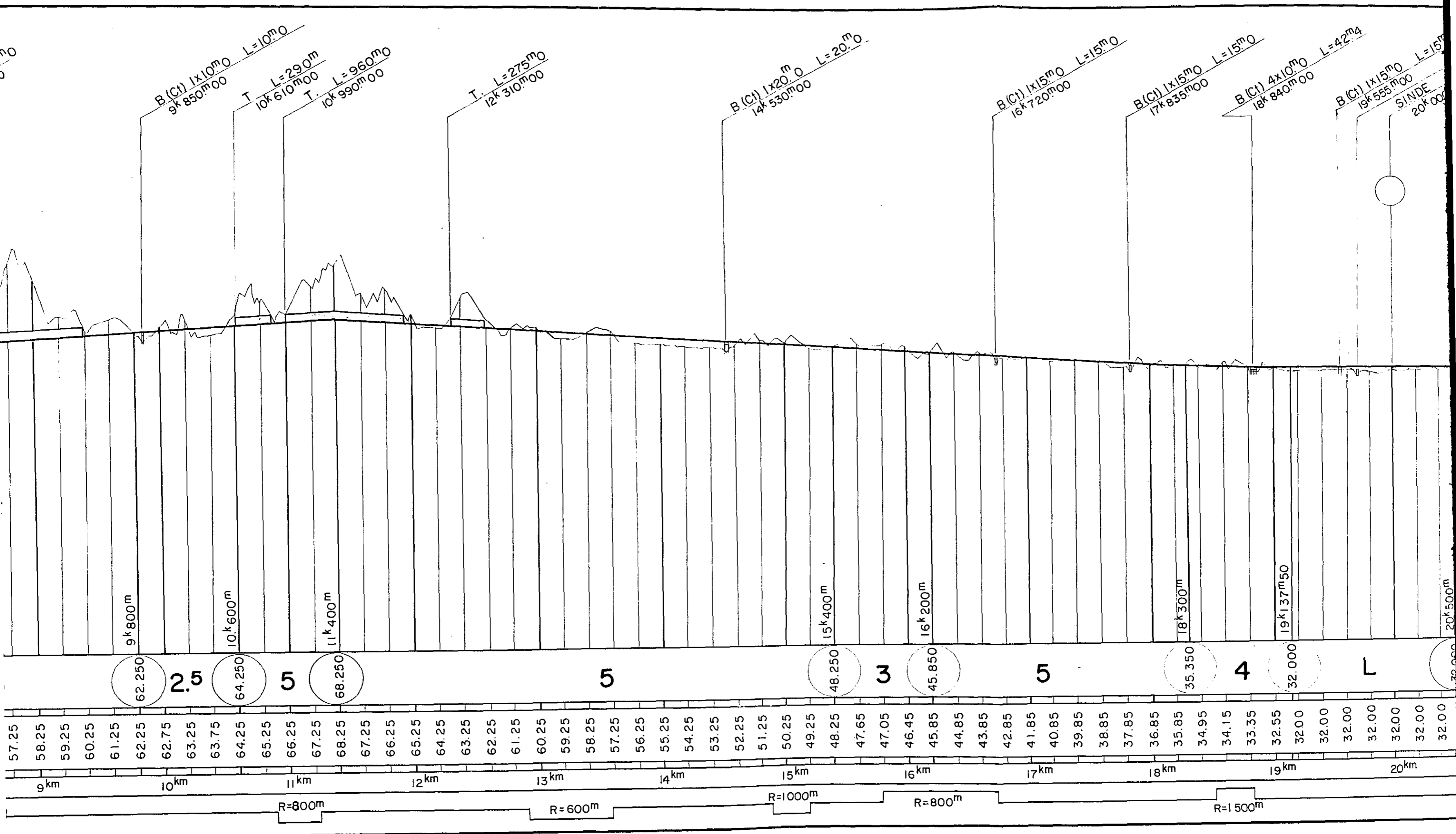

PROJECT	IRRAWADDY-RIVER BRIDGE	
SITE NO.	3	FIGURE NO. 7-10
SCALE	V=1:2,000	H=1:25,000

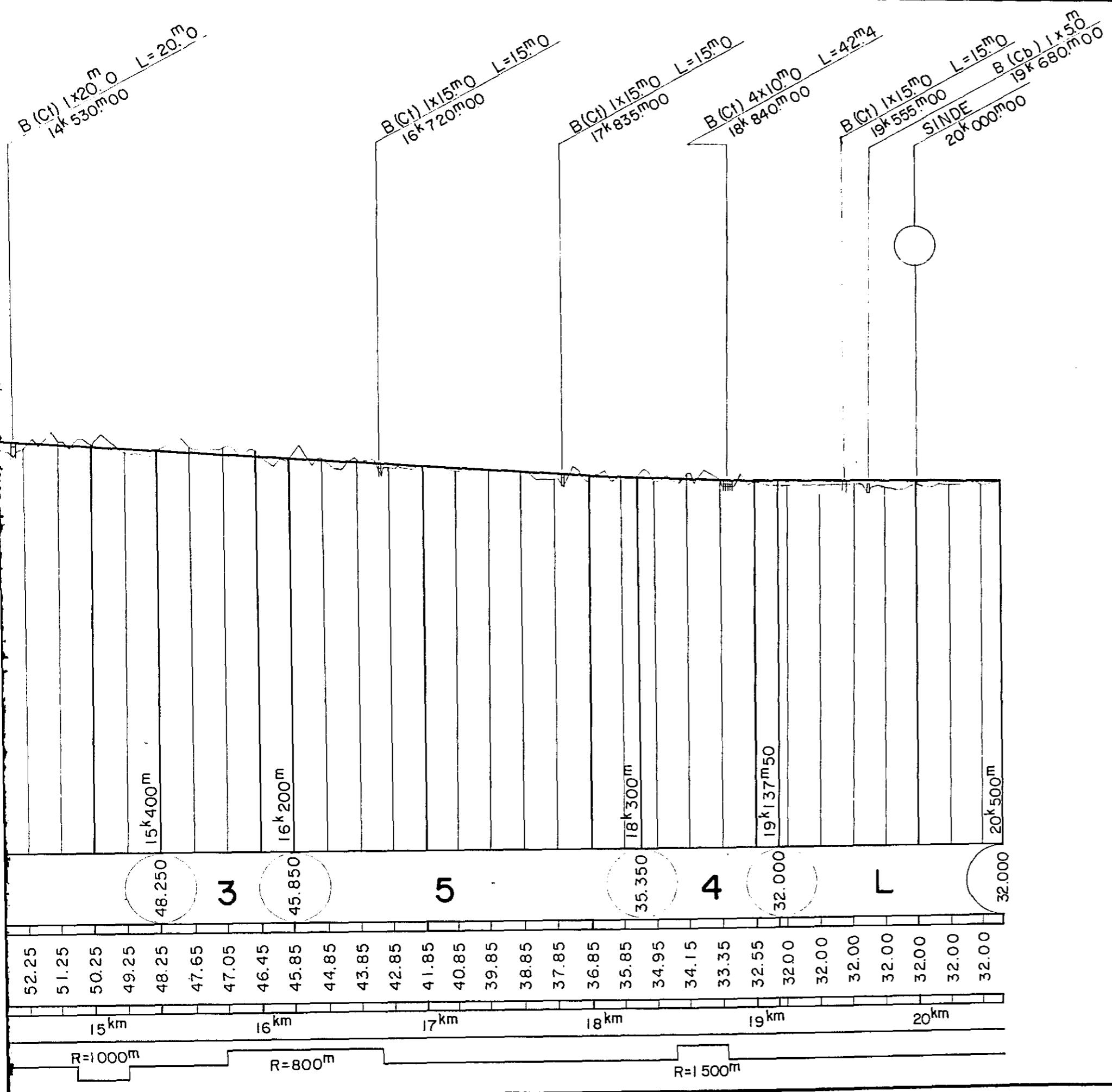

ACCESS RAILWAY  
VIA SITE No.3  
(PROFILE)

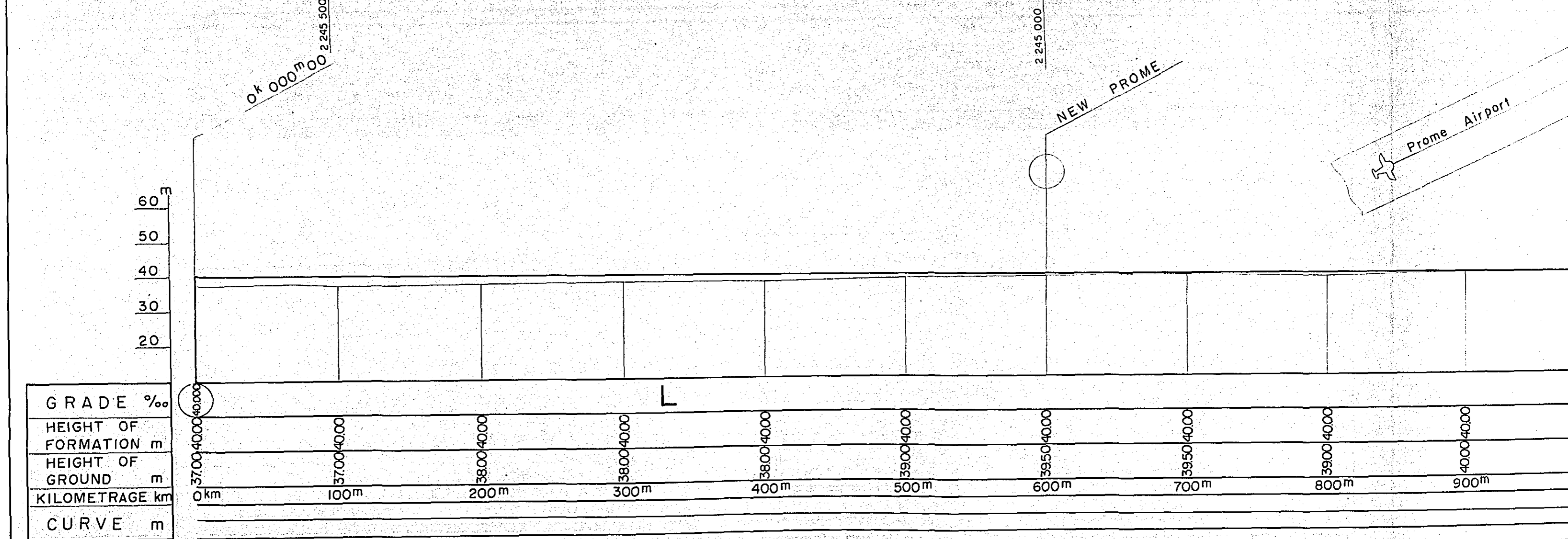
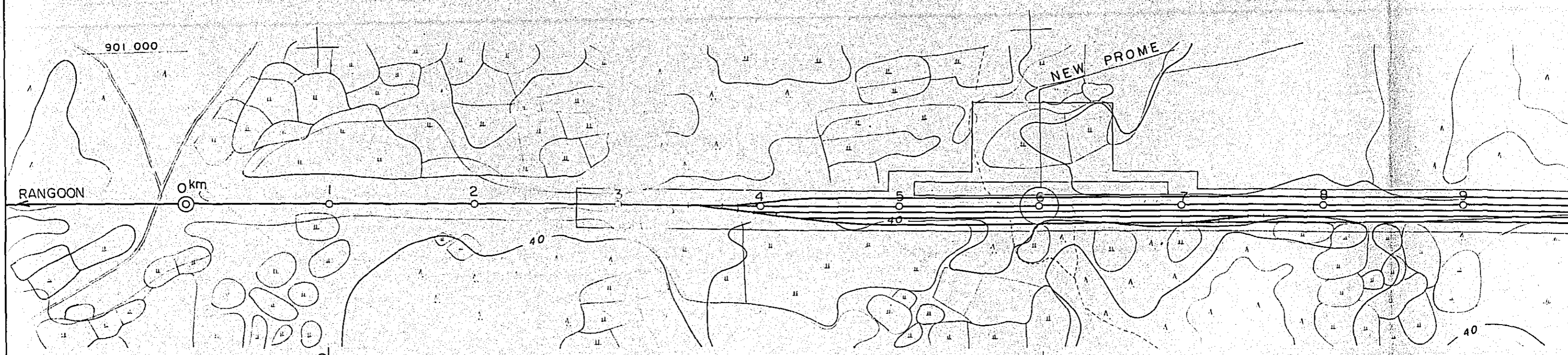

901 000  
RANGOON

NEW PROME

Prome Airport

60 m  
50  
40  
30  
20

0 km 100m 200m 300m 400m 500m 600m 700m 800m 900m



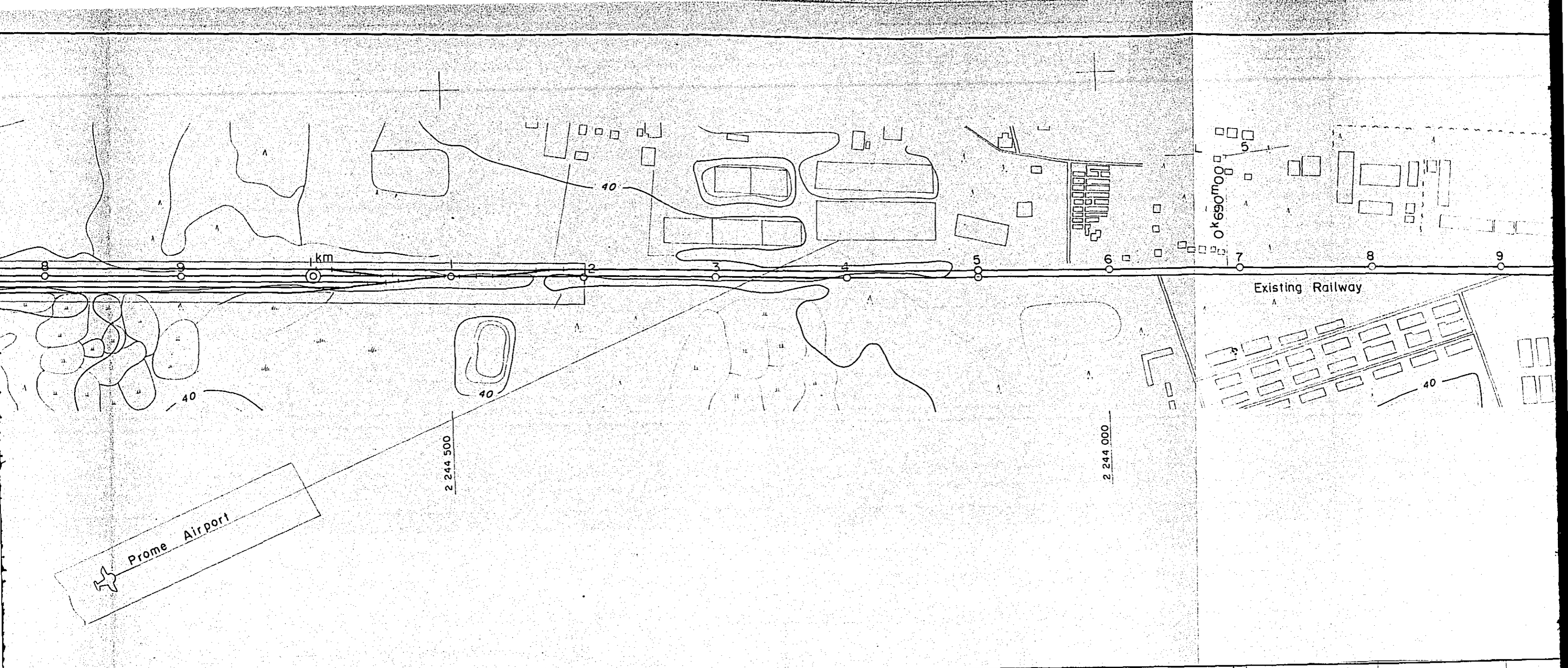

3900	4000	4000	3980	3980	3900	3900	3980	4000	4000	4020	41.80	41.00
800m	900m	1km	100m	200m	300m	400m	500m	600m	690m	700m	800m	900m

V.C.  
 C.L. + 16.70  
 0  
 +0.011  
 0  
 40.000  
 40.200

PROJECT	IRRAWADDY RIVER BRIDGE	
SITE NO.	3	FIGURE NO. 7-11
SCALE	V=1:1000 H=1:2500	

$R = 1.000^m$   
 $I.A. = 7^\circ 30'$   
 $T.L. = 65^m 54$   
 $C.L. = 130^m 90$

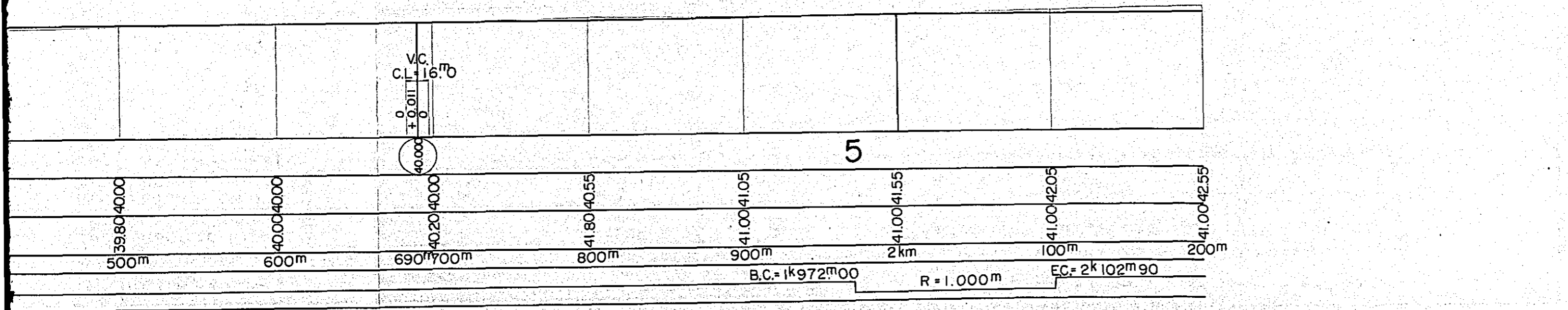
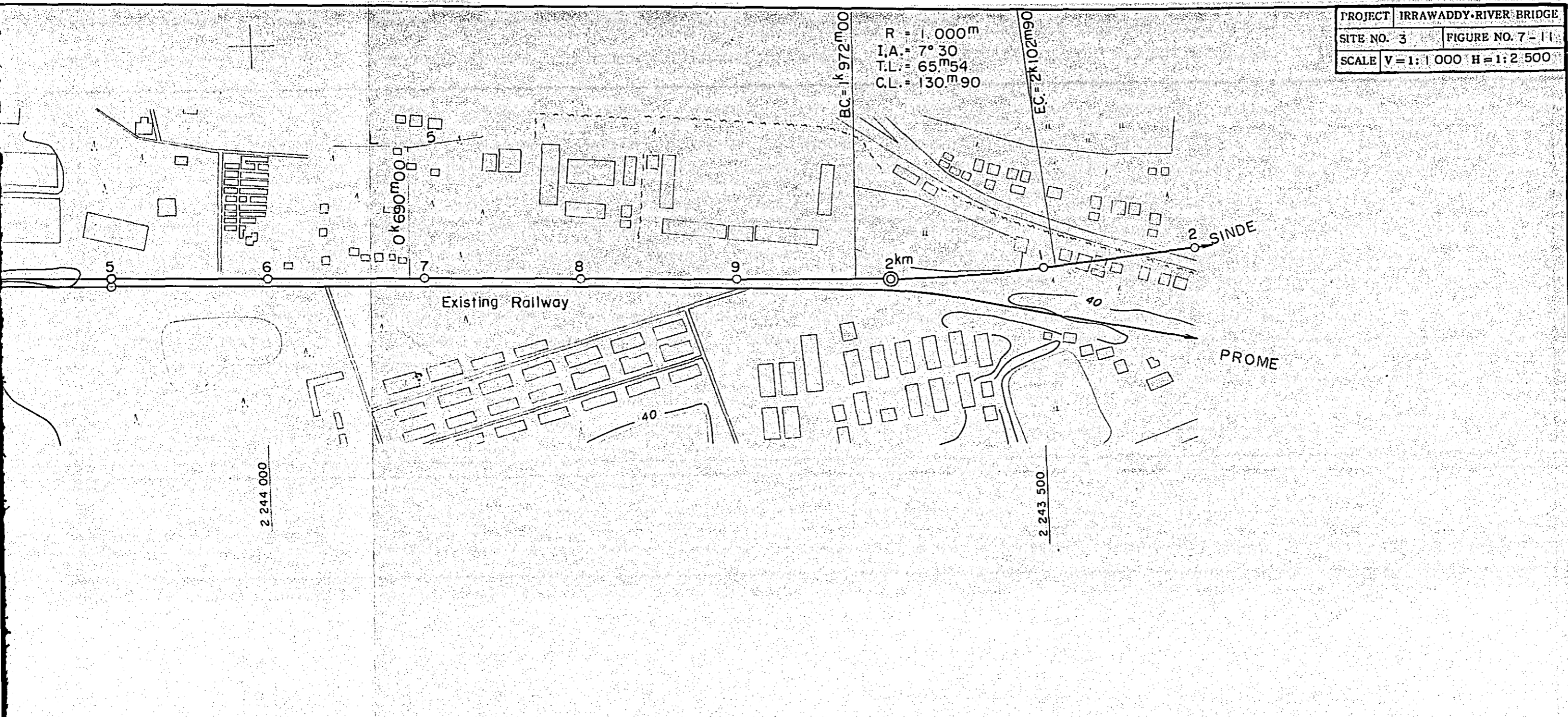

$B.C. = 1^k 972^m 00$        $R = 1.000^m$        $EC = 2^k 102^m 90$

R = 500m  
 I.A. = 60° 45'  
 T.L. = 293m06  
 C.L. = 530m15

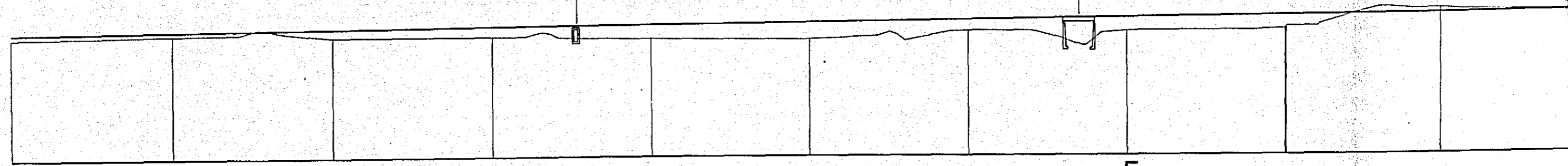
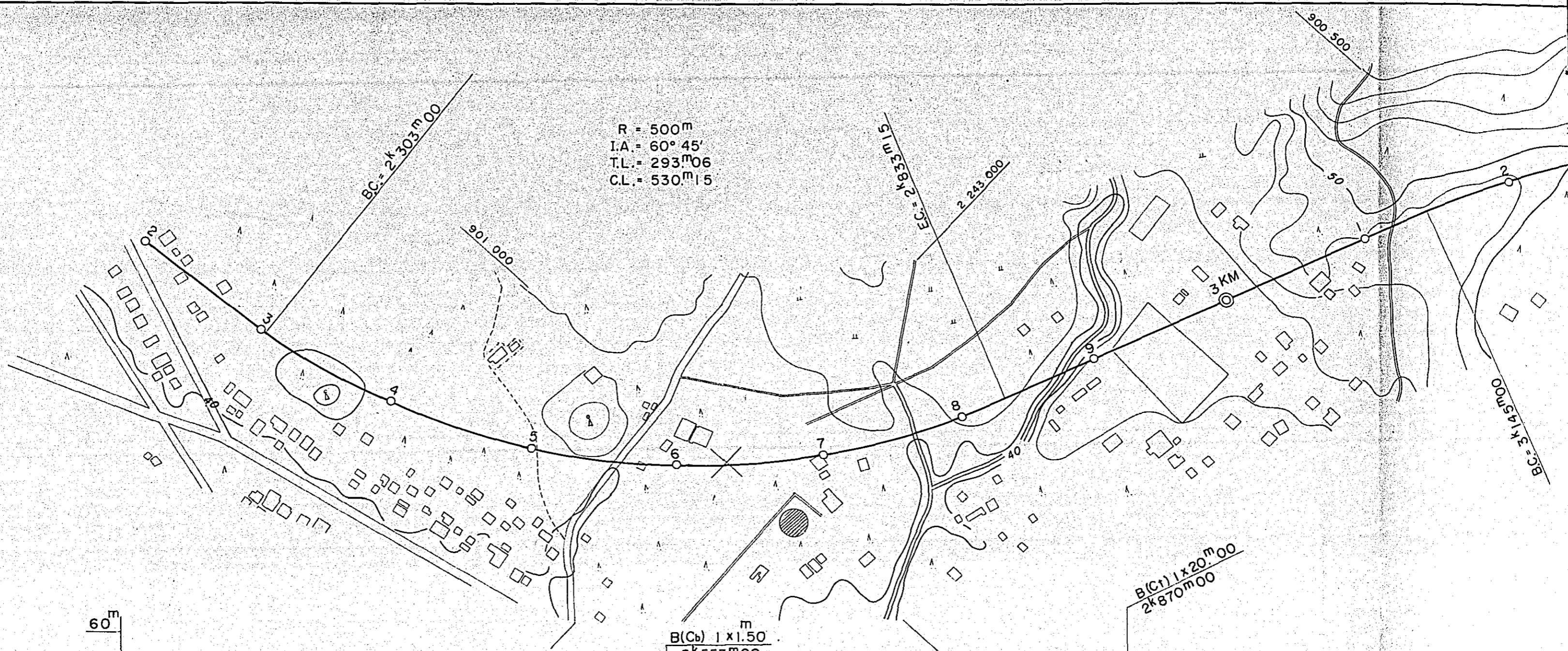

GRADE	‰
HEIGHT OF FORMATION	m
HEIGHT OF GROUND	m
KILOMETRAGE	km
CURVE	m

41.00	42.55	41.30	43.05	41.20	43.55	40.80	44.05	40.60	44.55	40.20	45.05	42.20	45.55	42.10	46.05	42.90	46.55	48.00	47.05
200m	300m	400m	500m	600m	700m	800m	900m	3km	100m										
B.C. = 2k303m00			R = 500m				EC = 2k833m15			B.C. = 3k145m00									



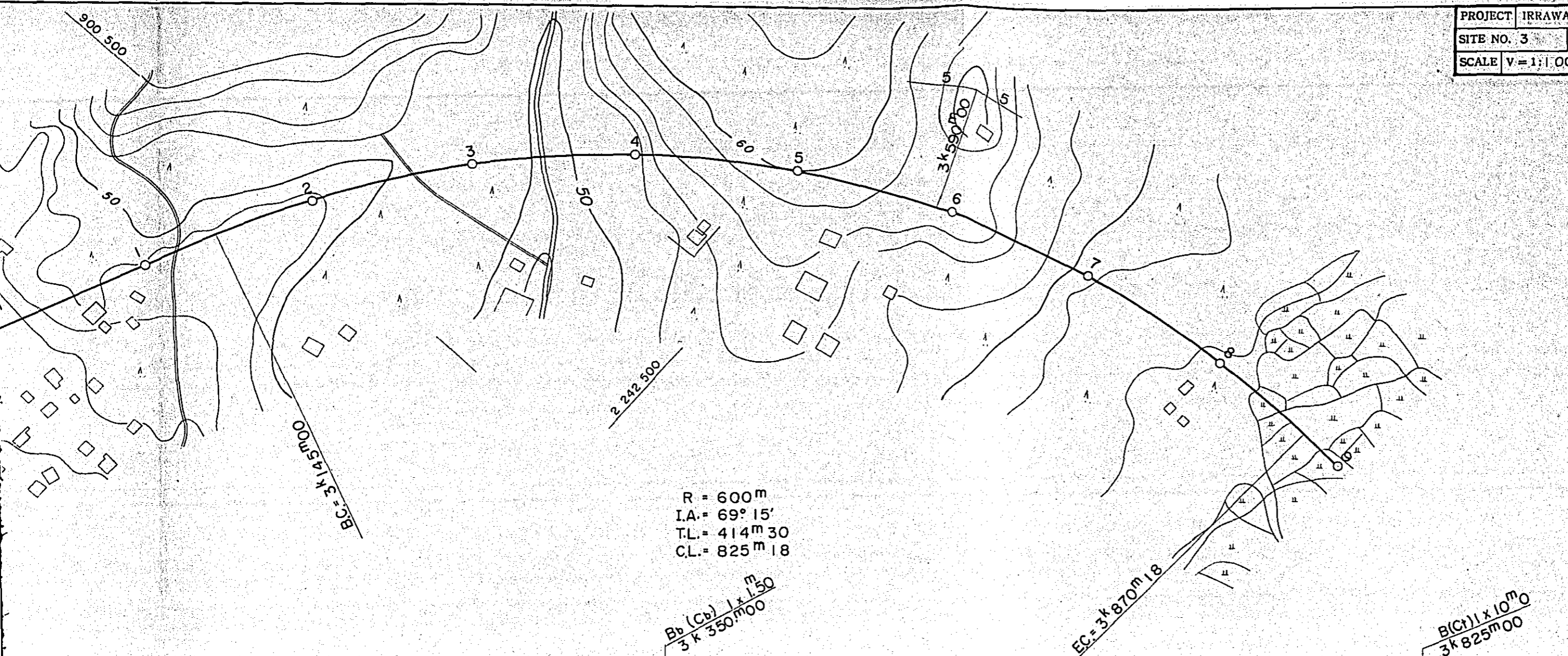

R = 600 m  
 I.A. = 69° 15'  
 T.L. = 414 m 30  
 C.L. = 825 m 18

B<sub>v</sub> (C<sub>v</sub>) 1 x 1.50 m  
 3 k 350 m 00

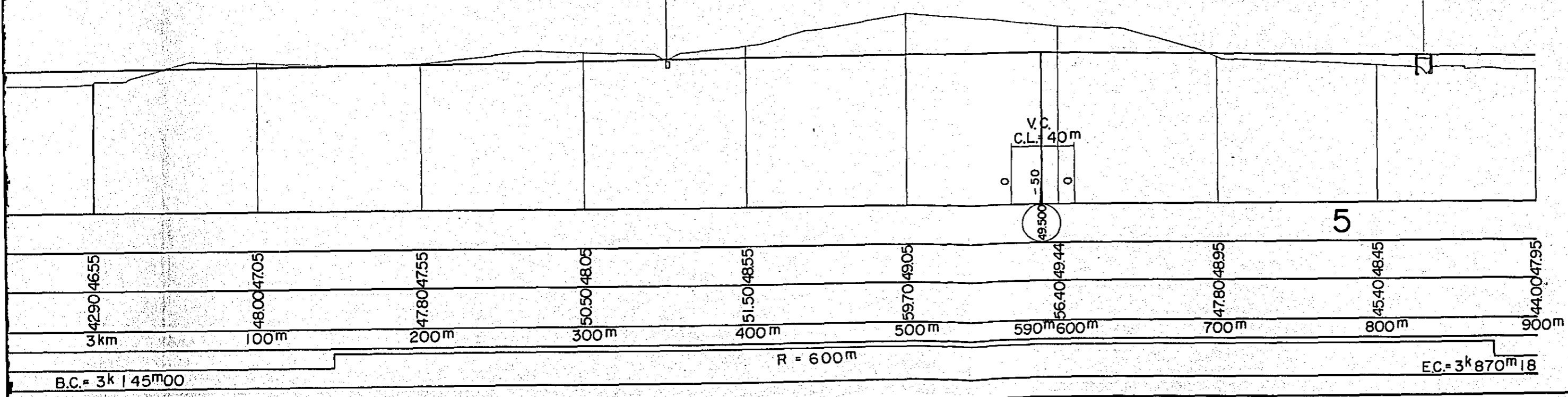

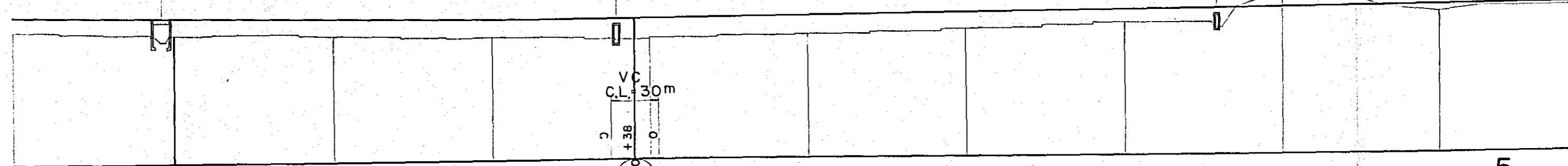
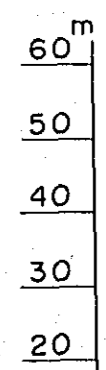
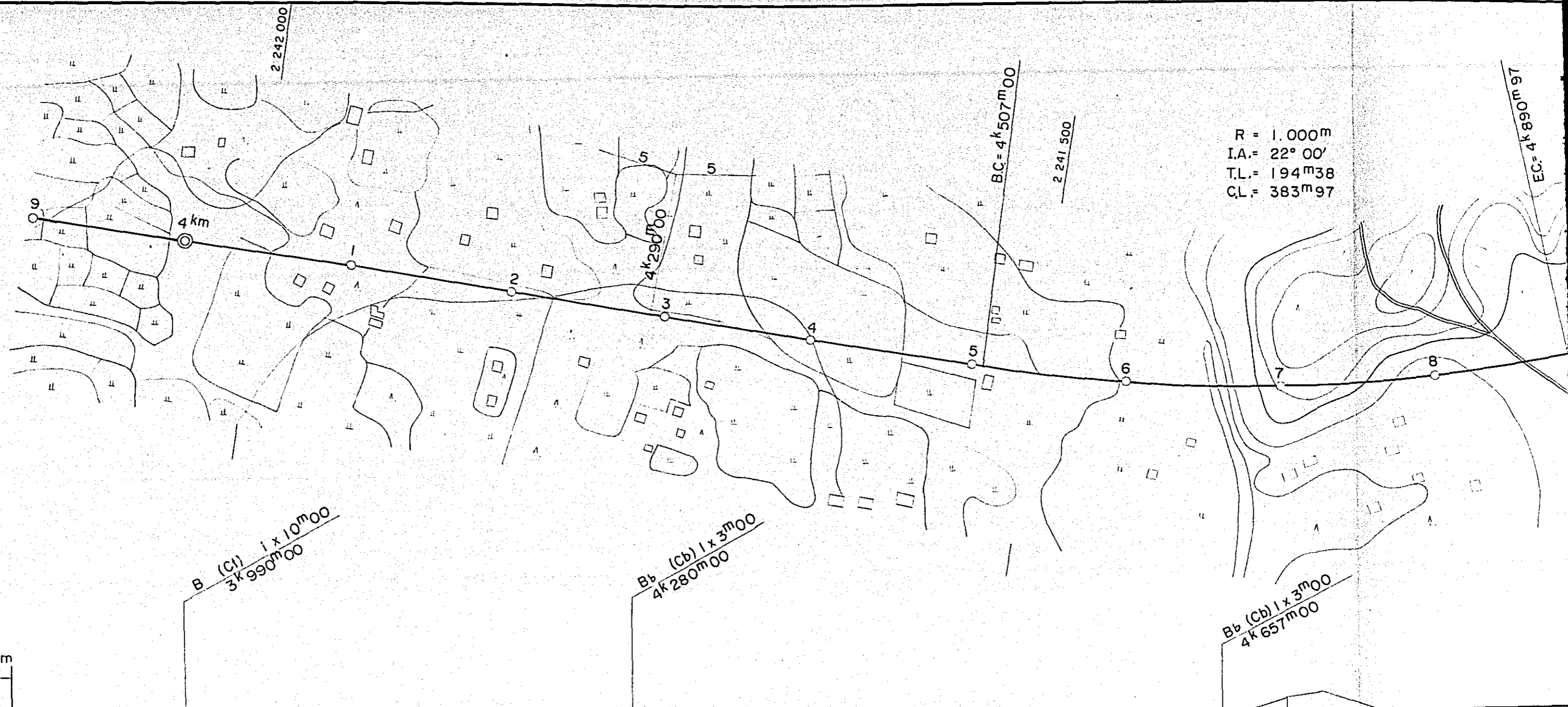

GRADE	‰
HEIGHT OF FORMATION	m
HEIGHT OF GROUND	m
KILOMETRAGE	km
CURVE	m

44.00	47.95	43.00	47.45	42.70	46.95	42.00	46.45	41.50	46.05	42.00	46.55	43.20	47.05	44.20	47.55	52.00	48.05	47.00	48.55
900m	4 km	100m	200m	290m	300m	400m	500m	600m	700m	800m	B.C. = 4k 507m00		R = 1.000m						

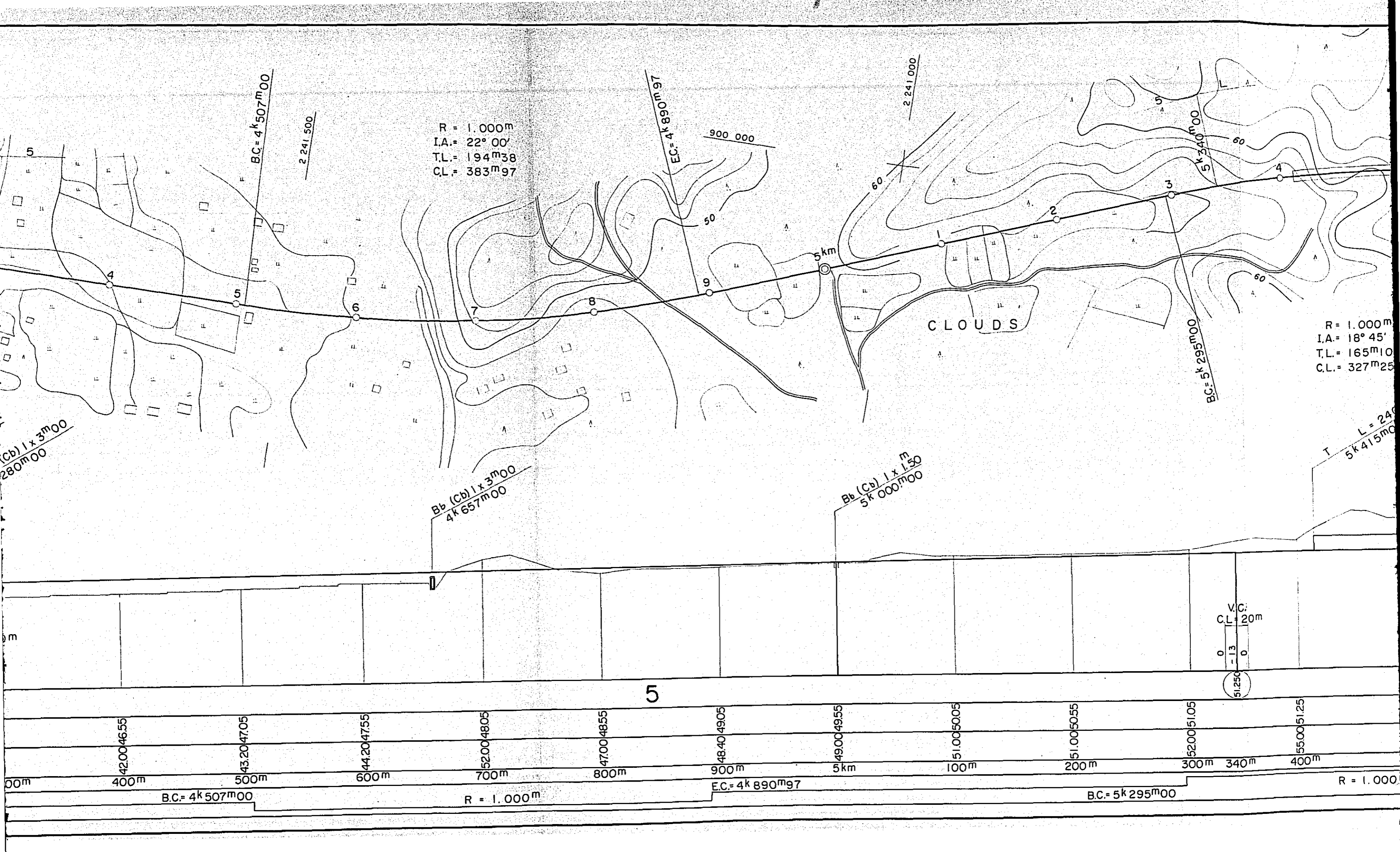

$R = 1.000\text{m}$   
 $I.A. = 22^\circ 00'$   
 $T.L. = 194\text{m}38$   
 $C.L. = 383\text{m}97$

$R = 1.000\text{m}$   
 $I.A. = 18^\circ 45'$   
 $T.L. = 165\text{m}10$   
 $C.L. = 327\text{m}25$

$(Cb) 1 \times 3\text{m}00$   
 $280\text{m}00$

$Bb (Cb) 1 \times 3\text{m}00$   
 $4\text{k} 657\text{m}00$

$Bb (Cb) 1 \times 1.50$   
 $5\text{k} 000\text{m}00$

$T = 5\text{k} 415\text{m}00$   
 $L = 24\text{m}$

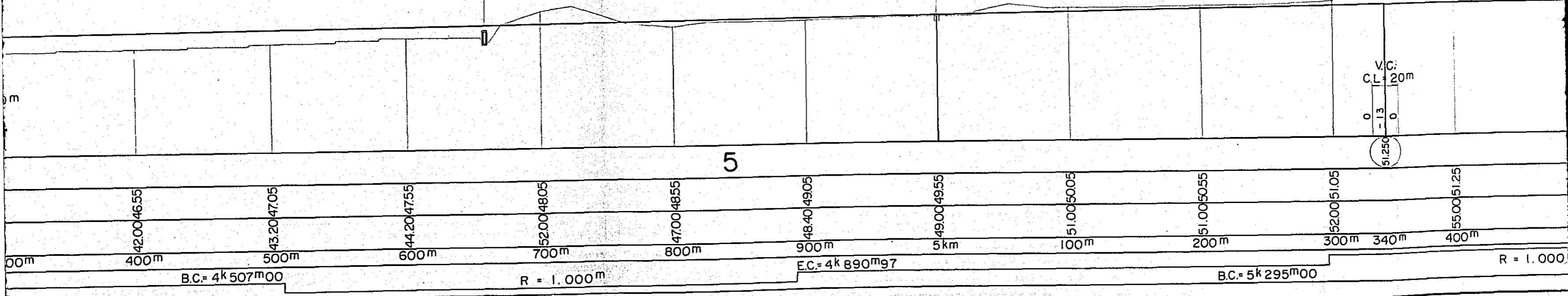
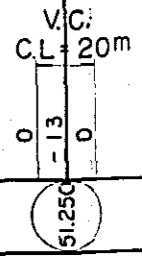

PROJECT	IRRAWADDY RIVER BRIDGE
SITE NO. 3	FIGURE NO. 7-13
SCALE	V=1:1 000 H=1:2 500

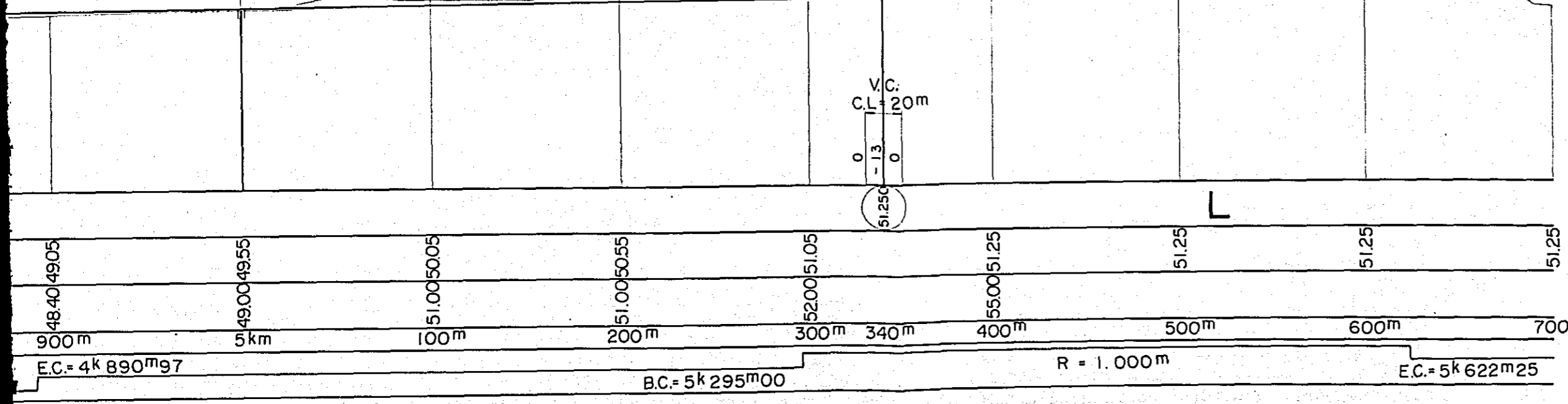
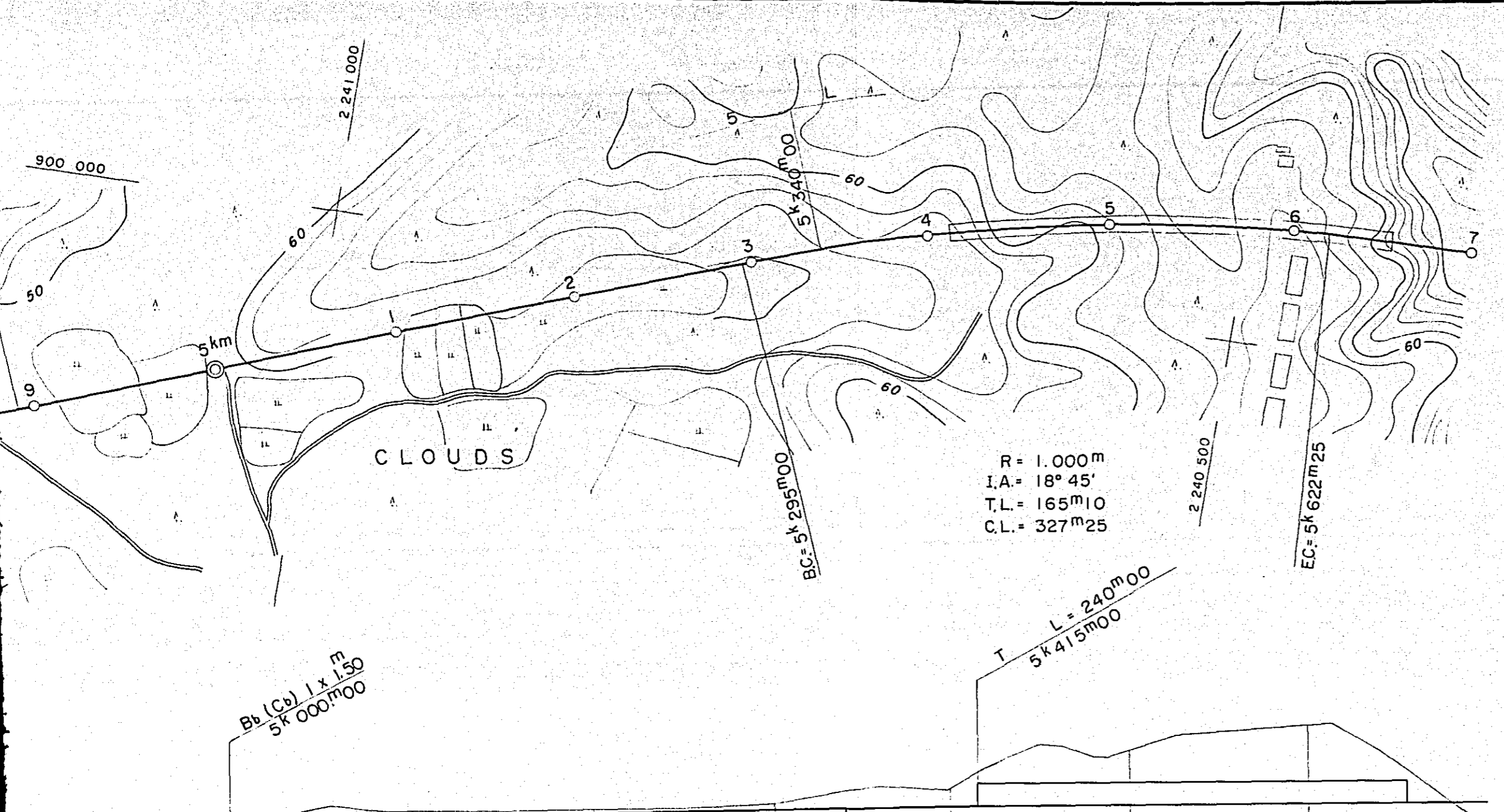





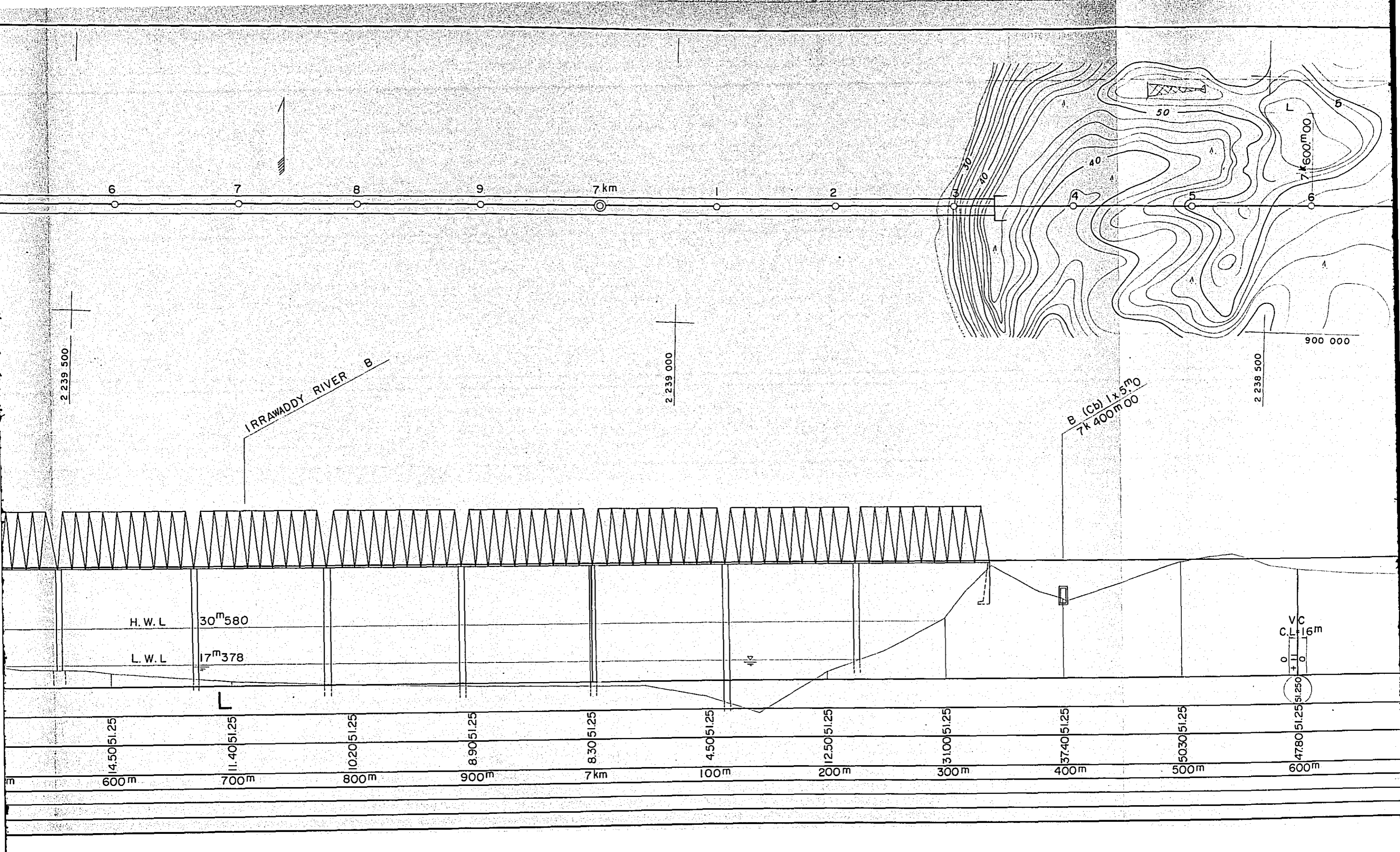

PROJECT IRRAWADDY RIVER BRIDGE  
 SITE NO. 3 FIGURE NO. 7-14  
 SCALE V=1:1 000 H=1:2 500

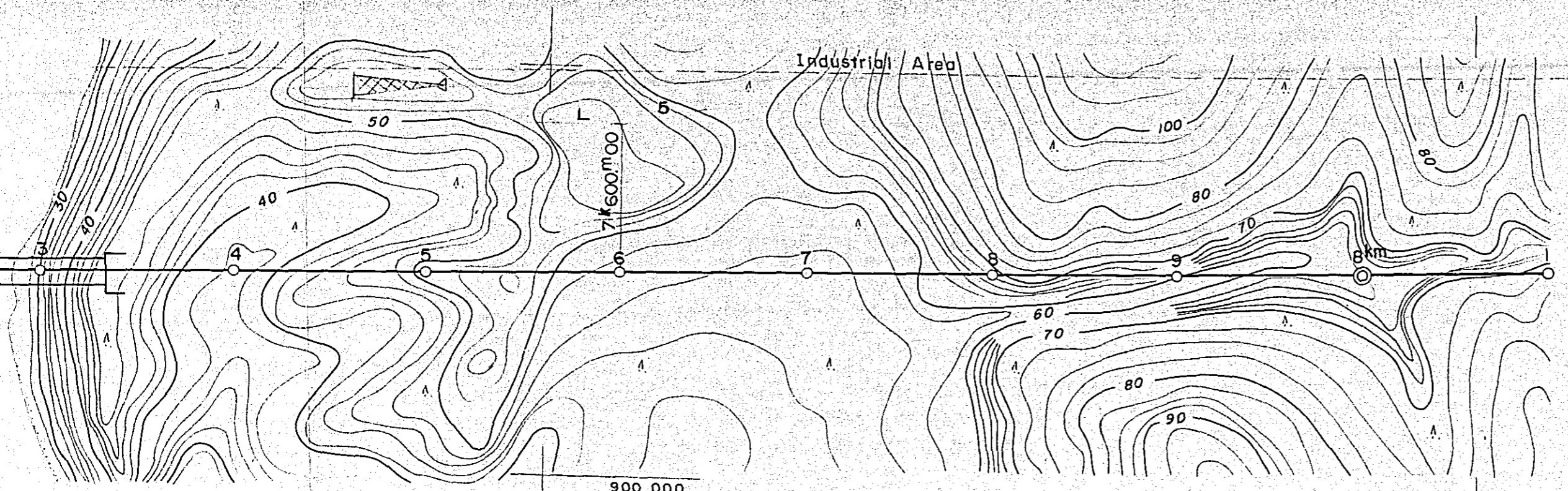

900 000

B (Cb) 1 x 5 m  
 7k 400 m 00

2 238 500

B<sub>b</sub> (Cb) 1 x 1.5 m  
 7k 700 m 00

2 238 000

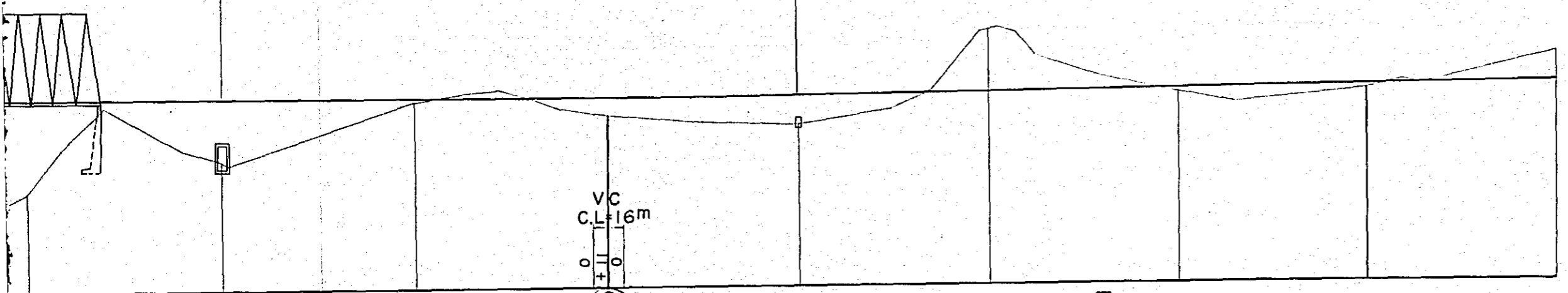

VC  
 C.L. 47.80  
 16m

5

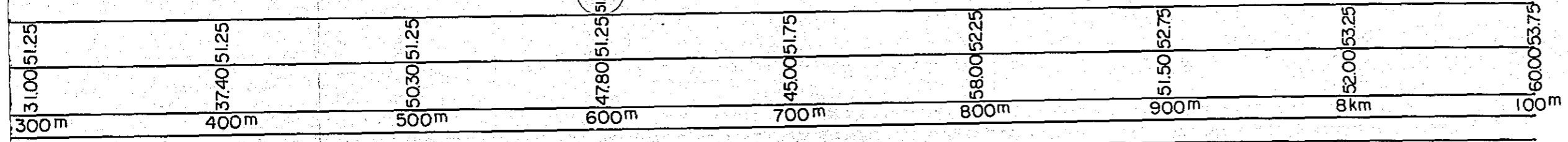



2 238 000

2 237 500

2 237 000

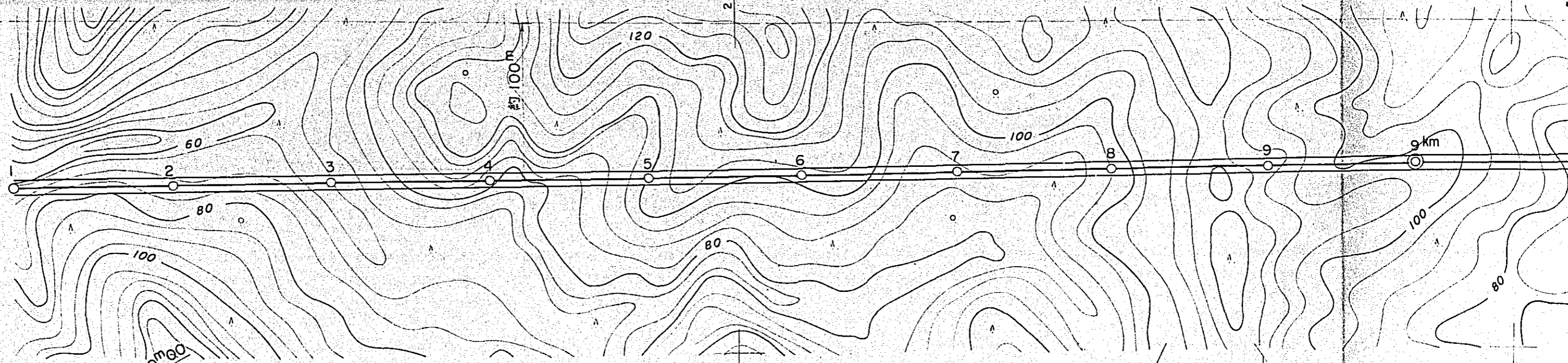

T. L. = 1350m60  
 8x100m00

60m  
 50  
 40  
 30  
 20

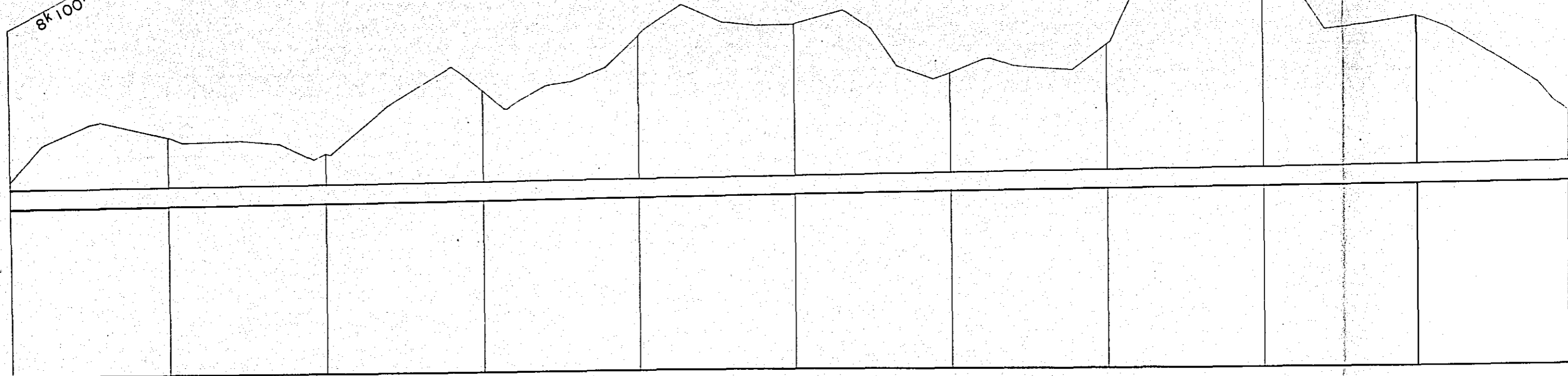

GRADE	‰
HEIGHT OF FORMATION	m
HEIGHT OF GROUND	m
KILOMETRAGE	km
CURVE	m

60.00	53.75	54.25	54.75	55.25	55.75	56.25	56.75	57.25	57.75	58.25	58.75
100m	200m	300m	400m	500m	600m	700m	800m	900m	9km	100	

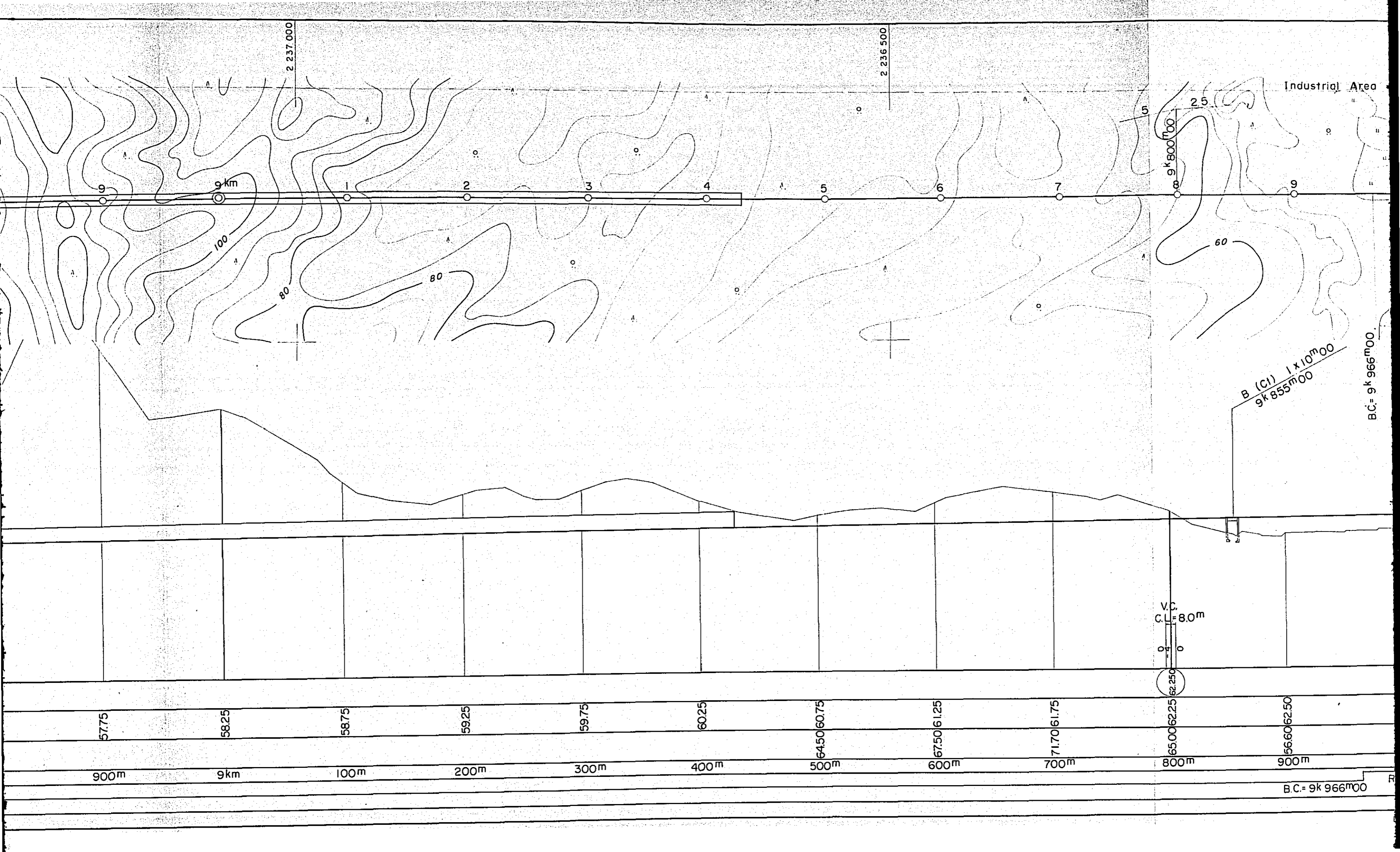

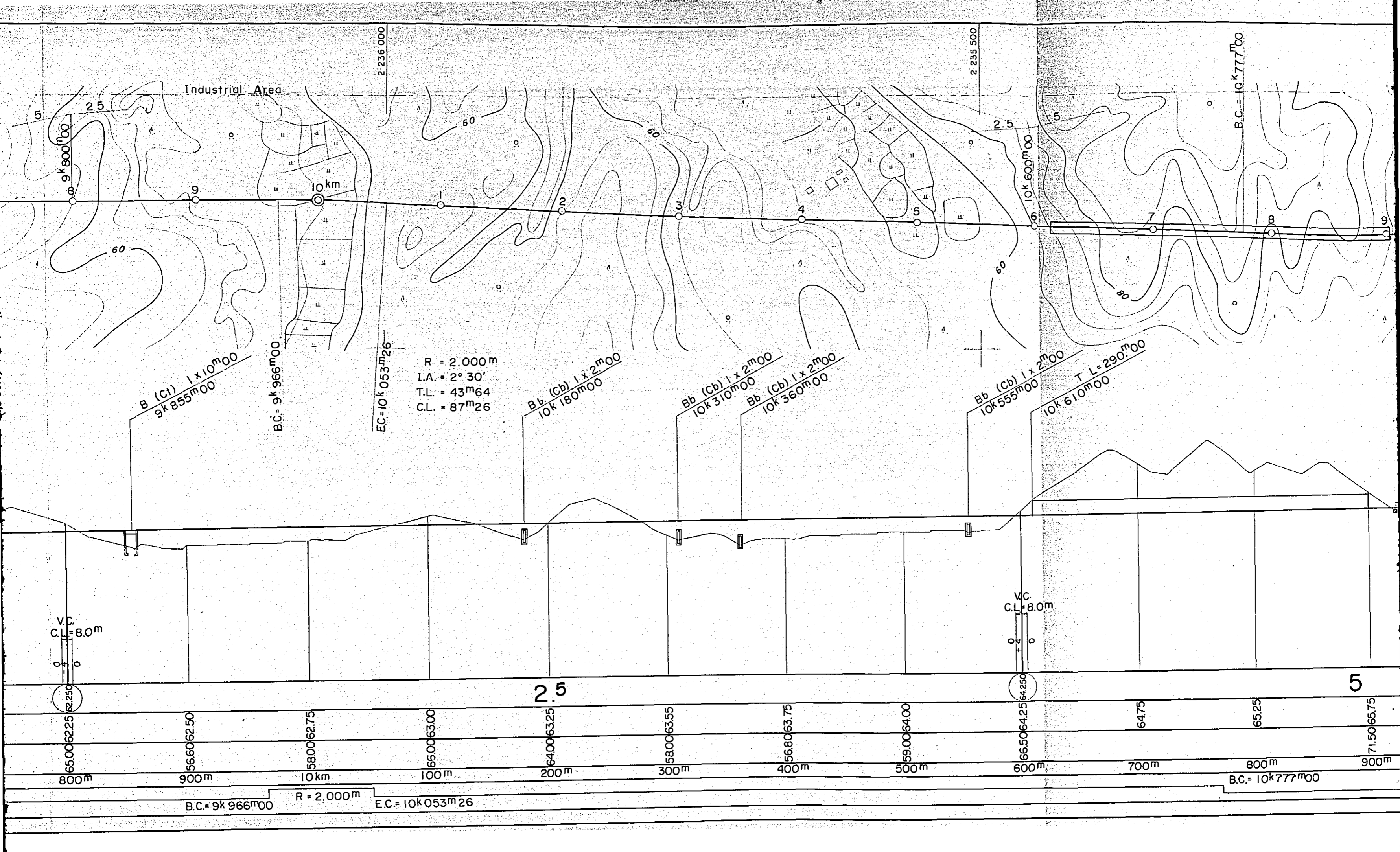

Industrial Area

2 236 000

2 235 500

B.C. = 10' 777' 00

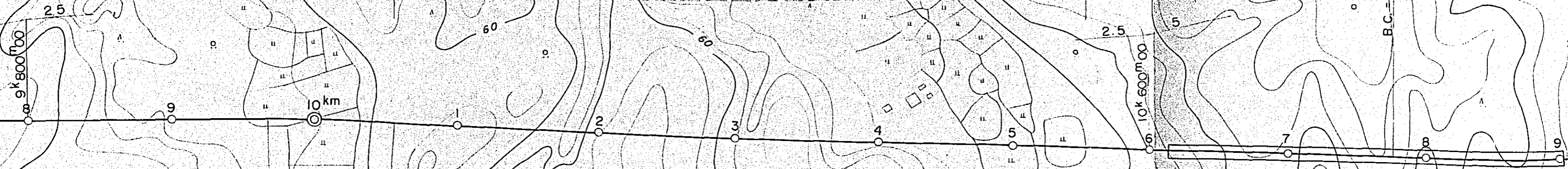

B (C) 1 x 10' 00  
9' 855' 00

B.C. = 9' 966' 00

E.C. = 10' 053' 26

R = 2.000 m  
I.A. = 2° 30'  
T.L. = 43' 64  
C.L. = 87' 26

Bb (Cb) 1 x 2' 00  
10' 180' 00

Bb (Cb) 1 x 2' 00  
10' 310' 00

Bb (Cb) 1 x 2' 00  
10' 360' 00

Bb (Cb) 1 x 2' 00  
10' 555' 00

T L = 290' 00  
10' 610' 00

V.C.  
C.L. = 8.0 m

V.C.  
C.L. = 8.0 m

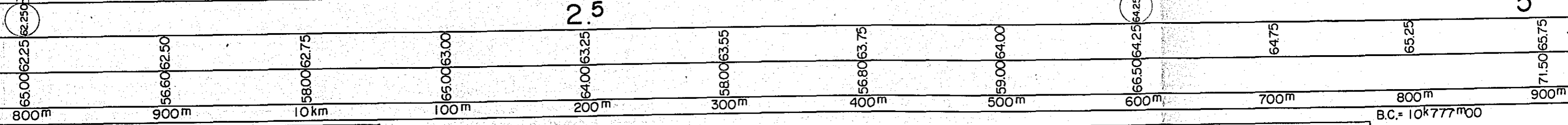

B.C. = 9' 966' 00 R = 2.000 m E.C. = 10' 053' 26

B.C. = 10' 777' 00



PROJECT	IRRAWADDY RIVER BRIDGE	
SITE NO.	3	FIGURE NO. 7-15
SCALE	V = 1:1 000 H = 1:2 500	

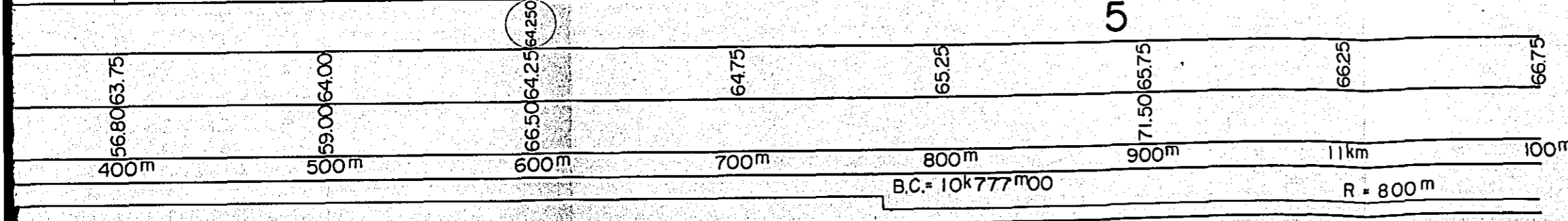
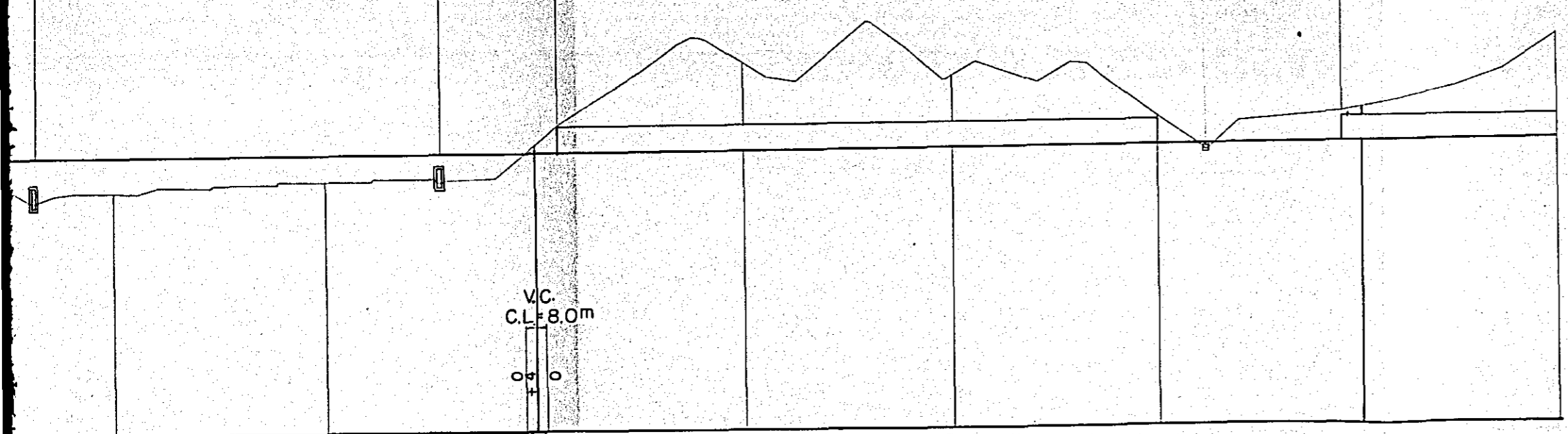
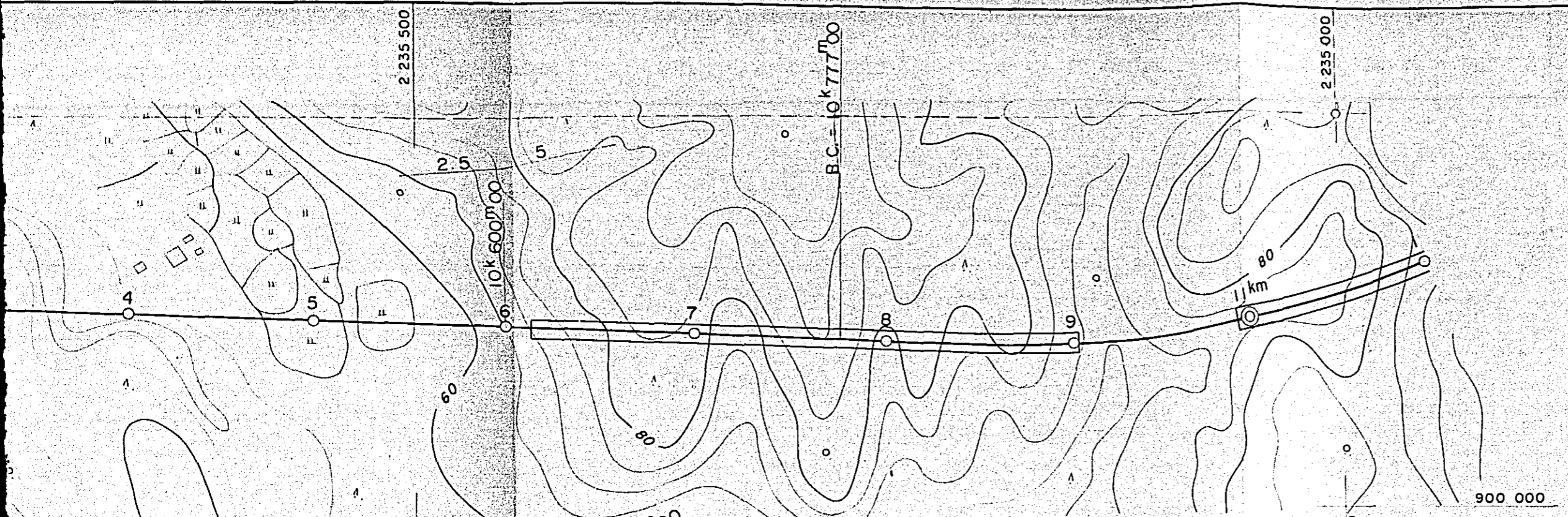



R = 800m  
 I.A. = 43° 45'  
 T.L. = 321 m 19  
 C.L. = 610 m 86

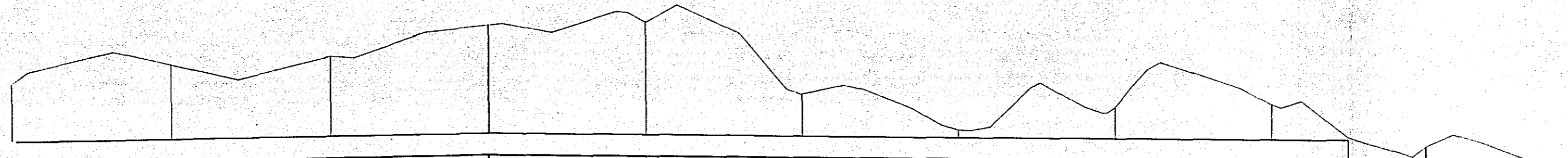
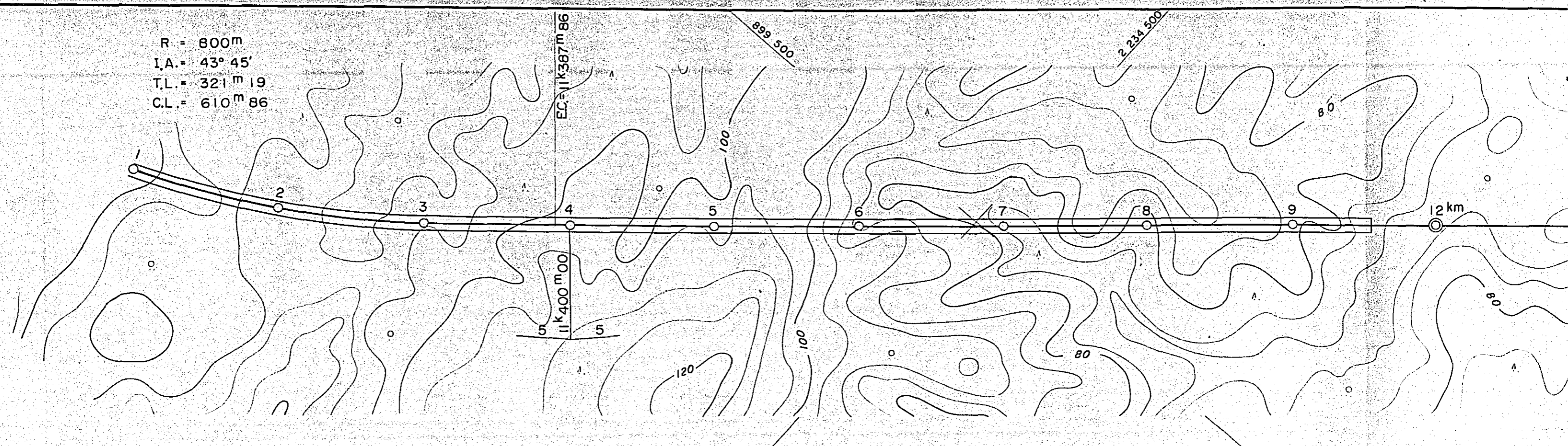

60 m  
 50  
 40  
 30  
 20

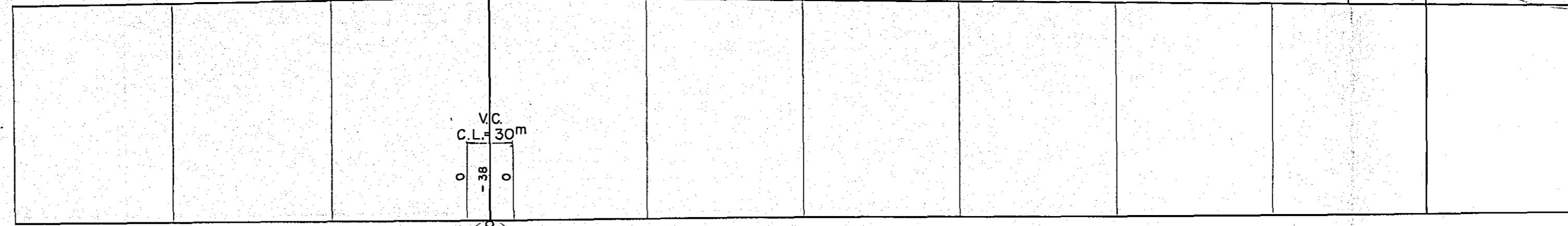

GRADE %	5
HEIGHT OF FORMATION m	
HEIGHT OF GROUND m	
KILOMETRAGE km	
CURVE m	

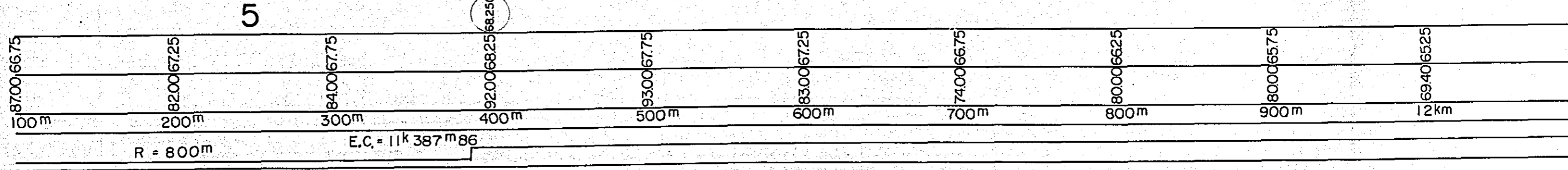

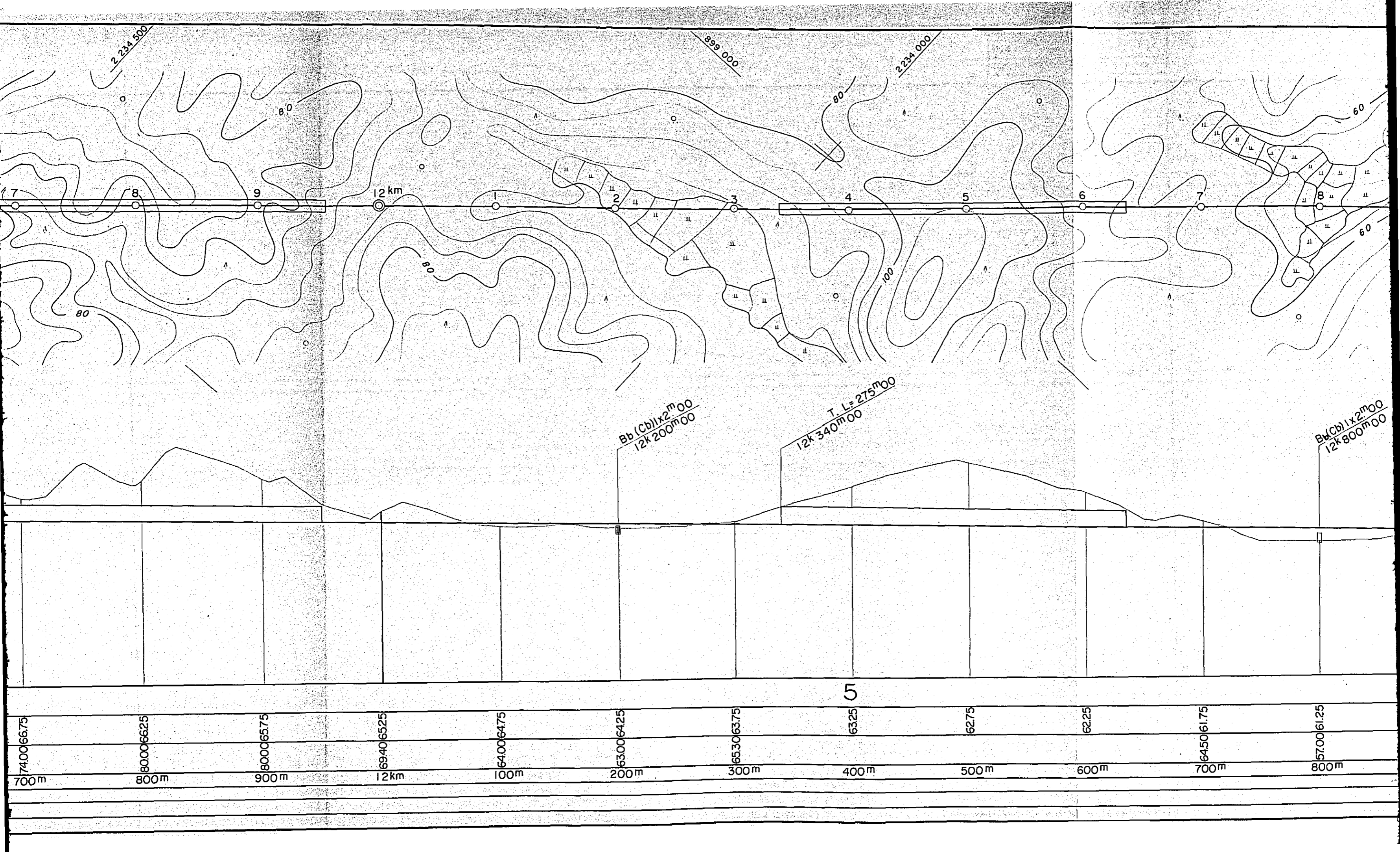

2 234 500

899 000

2 234 000

80

80

60

7

8

9

12 km

1

2

3

4

5

6

7

8

9

Bb (Cb) 1x2m 00  
12k 200m 00

T. L. = 275m 00  
12k 340m 00

Bb (Cb) 1x2m 00  
12k 800m 00

U

740066.75  
700m

800066.25  
800m

800065.75  
900m

69.40 65.25  
12km

64.00 64.75  
100m

63.00 64.25  
200m

65.30 63.75  
300m

63.25  
400m

62.75  
500m

62.25  
600m

64.50 61.75  
700m

57.00 61.25  
800m

PROJECT	IRRAWADDY RIVER BRIDGE
SITE NO. 3	FIGURE NO. 7 - 16
SCALE	V = 1:1 000 H = 1:2 500

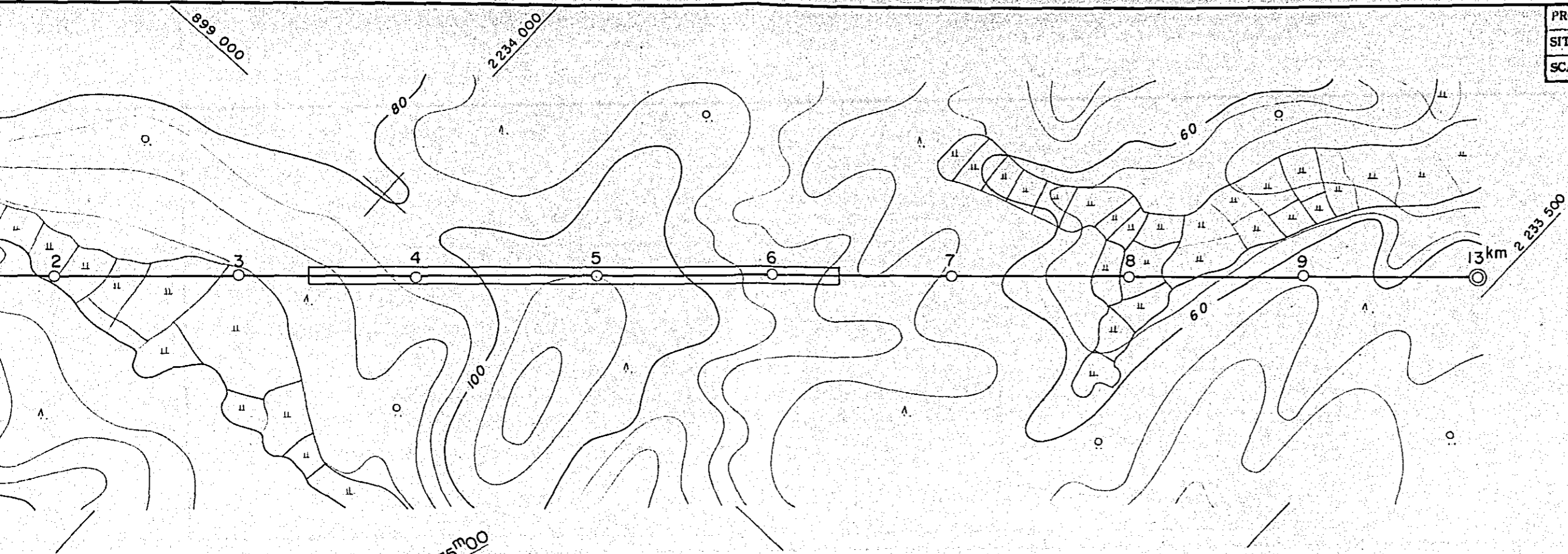

B/Cb) 1x2m<sup>00</sup>  
12x 200m<sup>00</sup>

T. L. = 275m<sup>00</sup>  
12x 340m<sup>00</sup>

B/Cb) 1x2m<sup>00</sup>  
12x 800m<sup>00</sup>

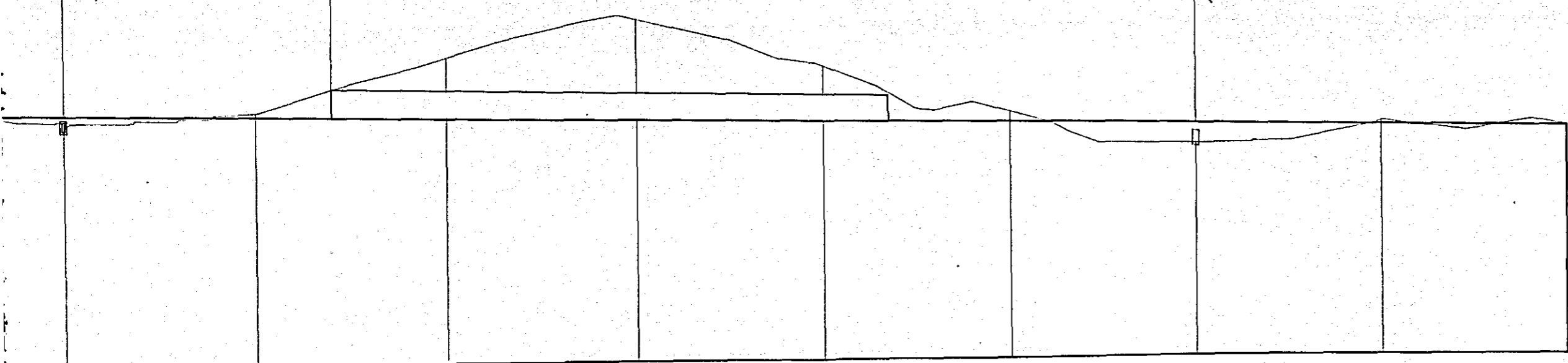

5

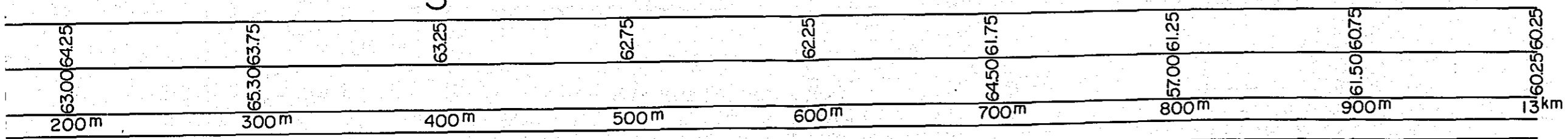



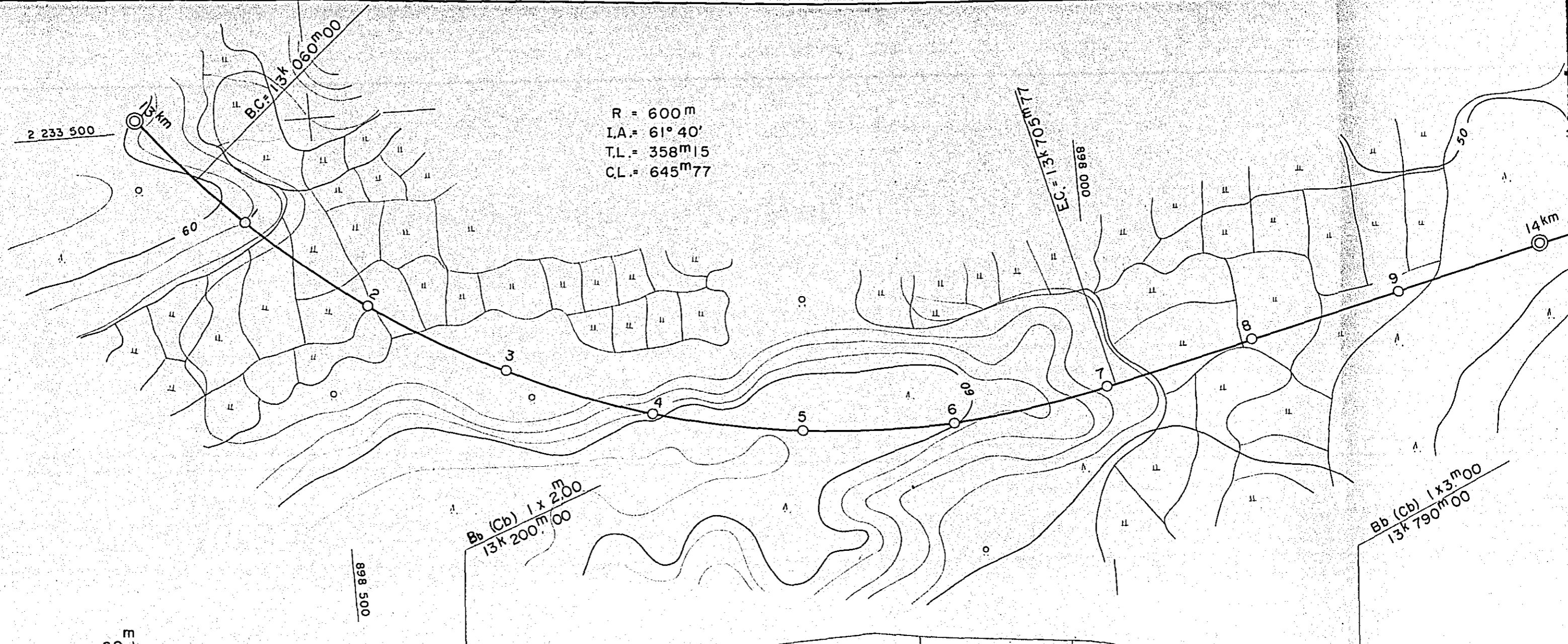

$R = 600\text{ m}$   
 $I.A. = 61^\circ 40'$   
 $T.L. = 358\text{ m}15$   
 $C.L. = 645\text{ m}77$

60 m  
 50  
 40  
 30  
 20

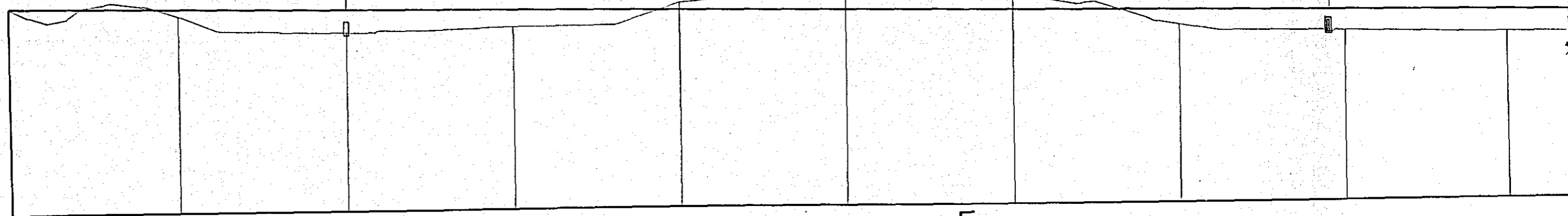

GRADE	‰
HEIGHT OF FORMATION	m
HEIGHT OF GROUND	m
KILOMETRAGE	km
CURVE	m

60.25	58.00	53.80	54.50	60.30	62.30	60.00	53.30	51.40	50.50
13 km	100 m	200 m	300 m	400 m	500 m	600 m	700 m	800 m	900 m
BC=13k 060m00		R = 600 m				EC=13k 705m77			

PROJECT IRRAWADDY RIVER BRIDGE  
 SITE NO. 3 FIGURE NO. 7-17  
 SCALE V=1:1 000 H=1:2 500

000 m  
 51° 40'  
 58m15  
 545m77

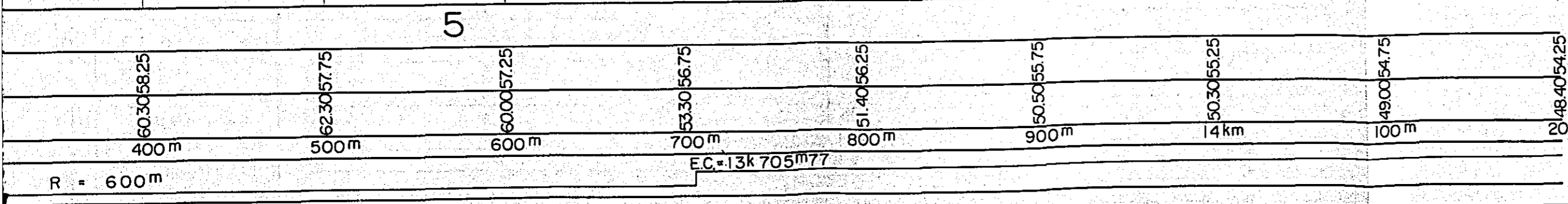
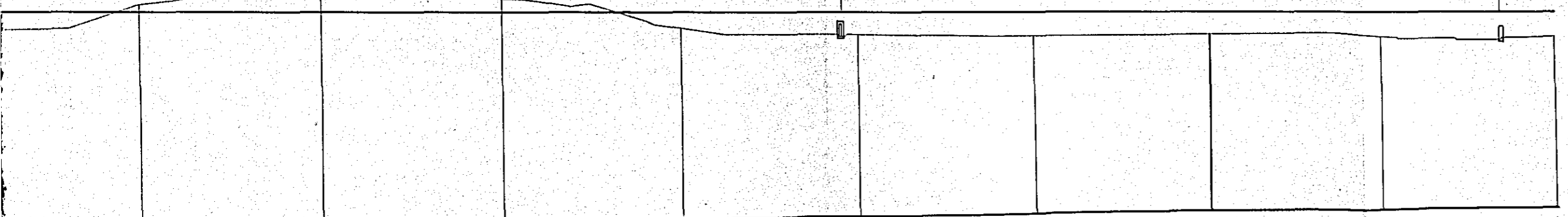
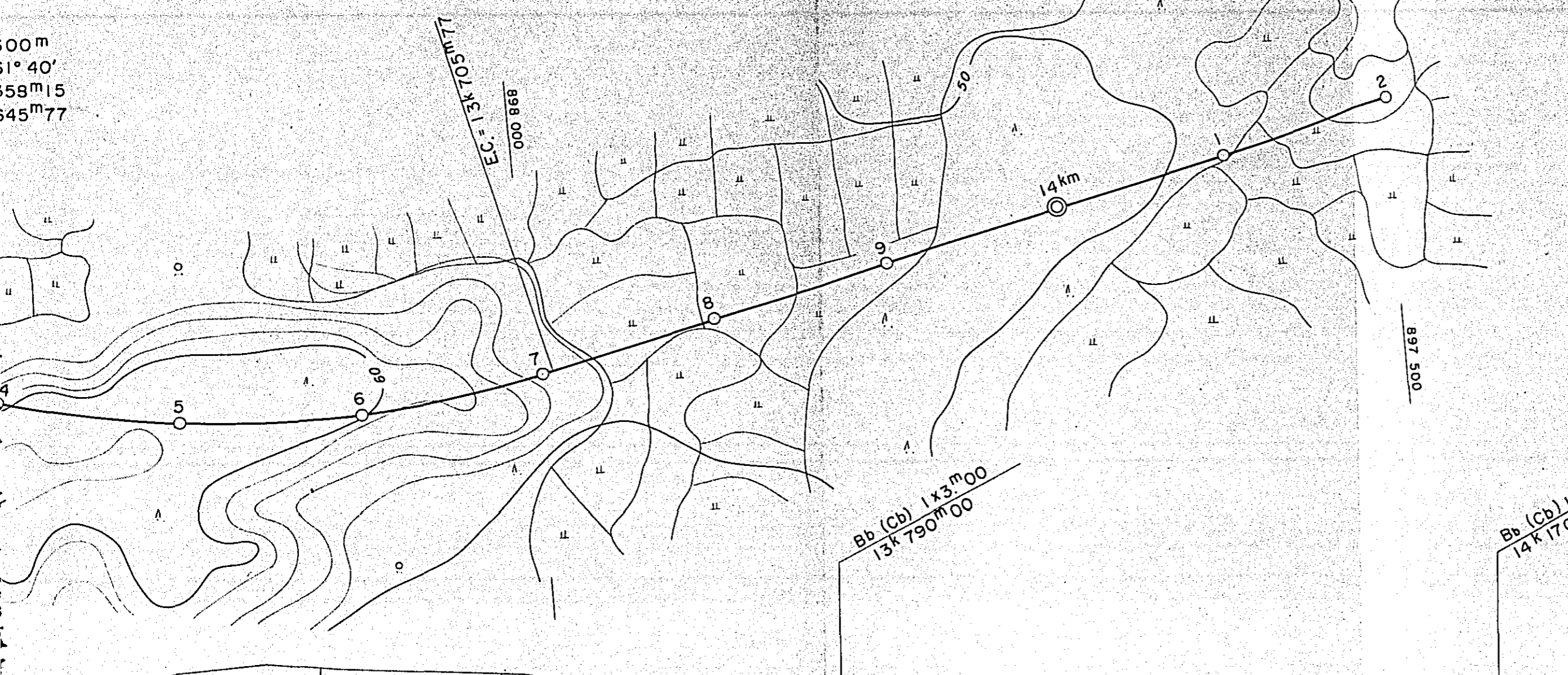





PROJECT	IRRAWADDY RIVER BRIDGE	
SITE NO.	3	FIGURE NO. 7-18
SCALE	V=1:1 000	H=1:2 500

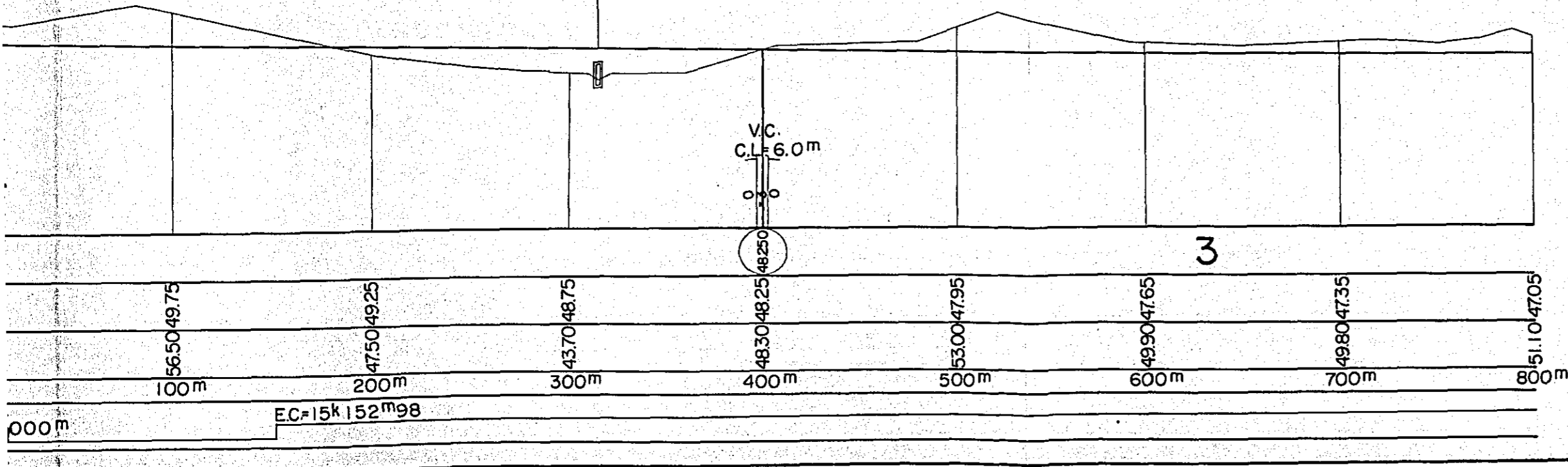
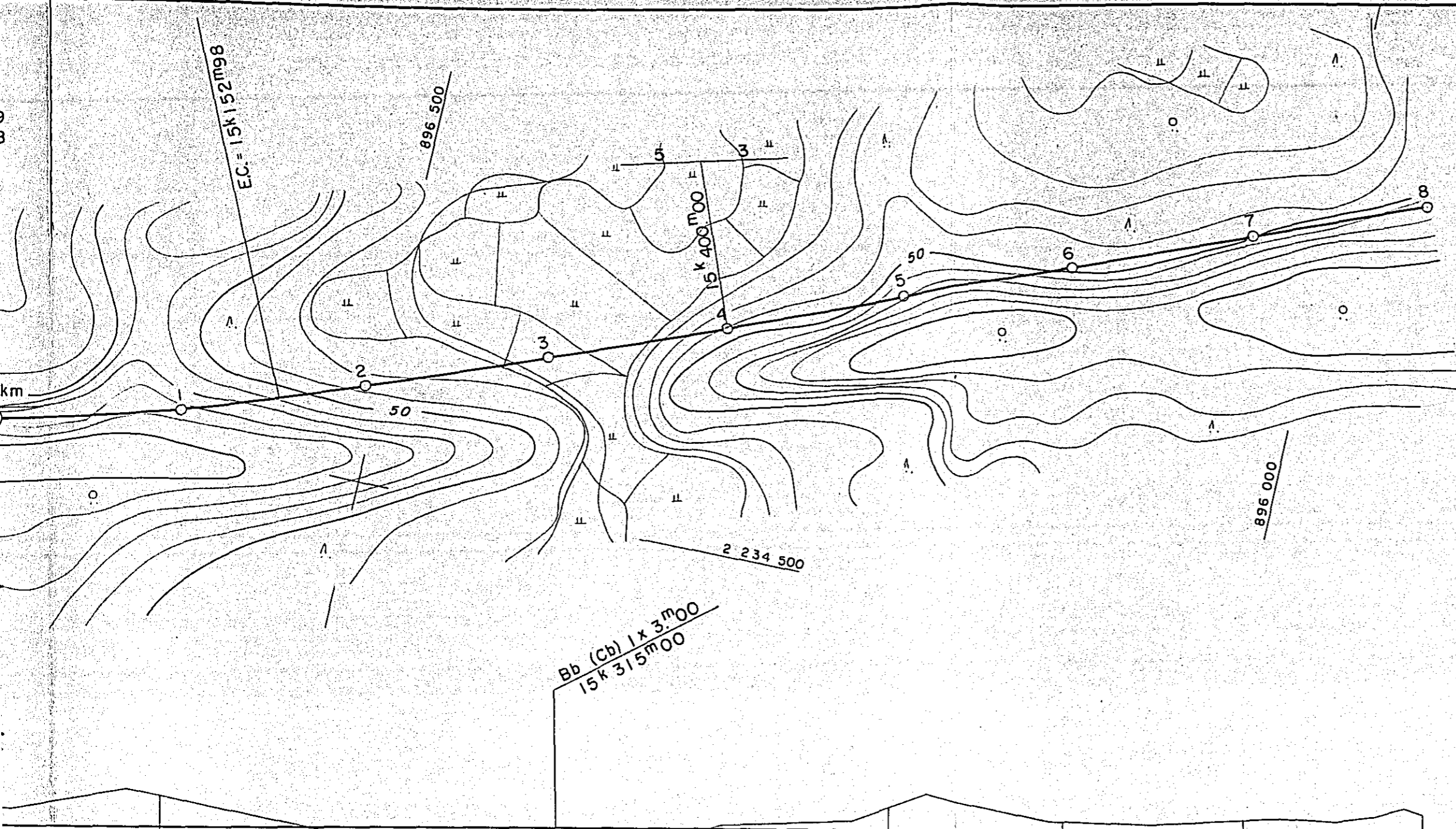

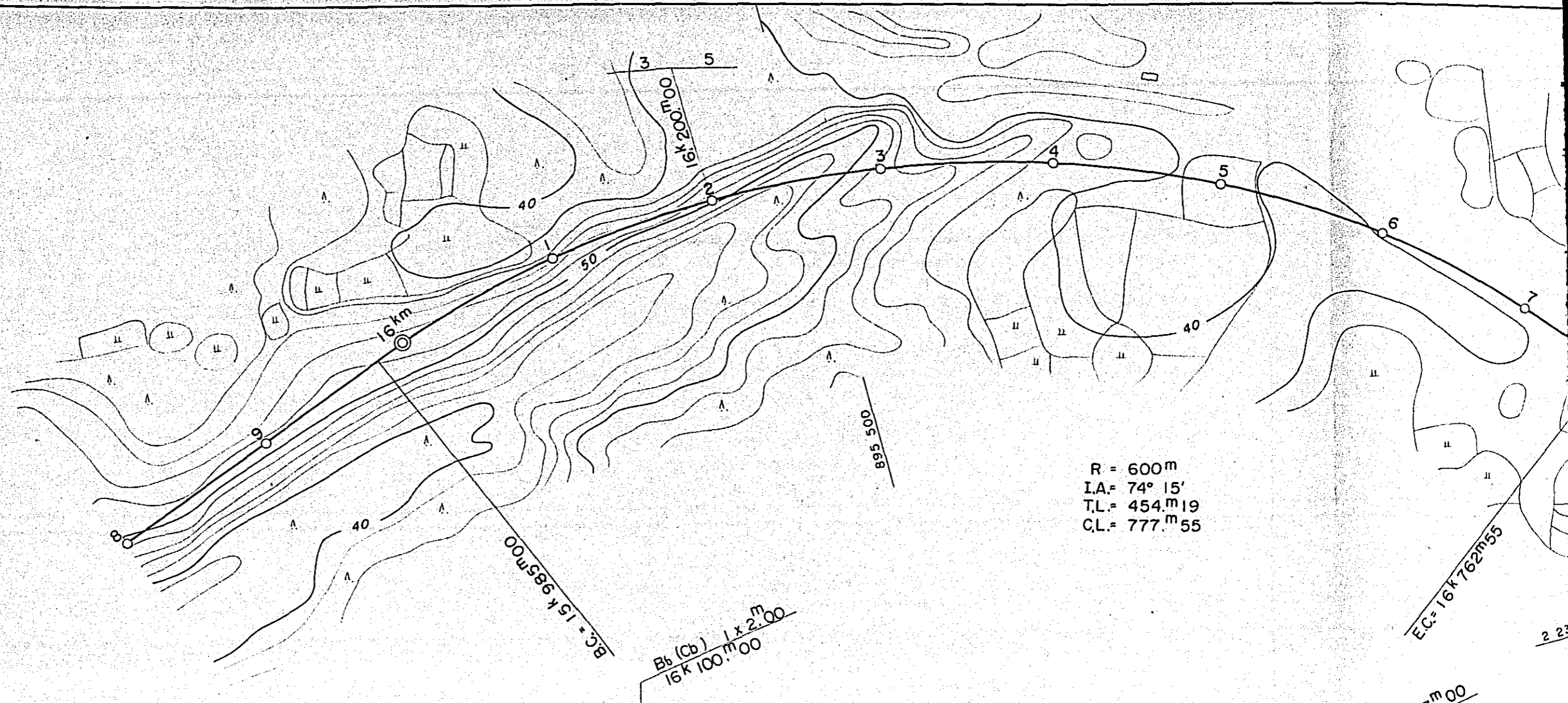

R = 600m  
 I.A. = 74° 15'  
 T.L. = 454m19  
 C.L. = 777m55

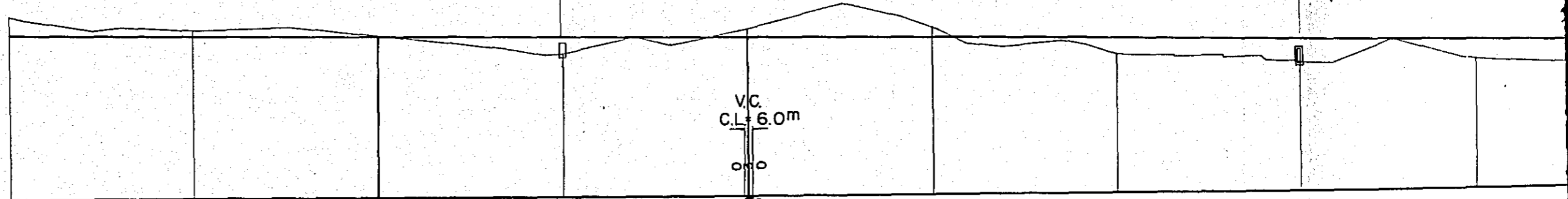
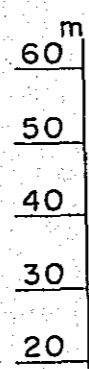

GRADE	‰
HEIGHT OF FORMATION	m
HEIGHT OF GROUND	m
KILOMETRAGE	km
CURVE	m

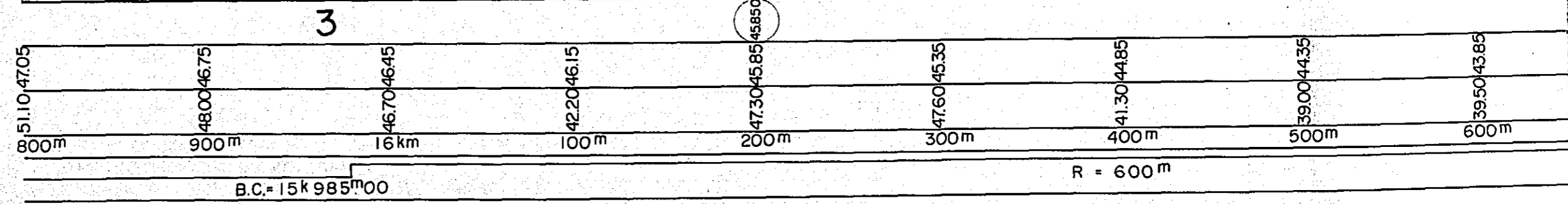



PROJECT	IRRAWADDY RIVER BRIDGE	
SITE NO.	3	FIGURE NO. 7-19
SCALE	V = 1:1 000	H = 1:2 500

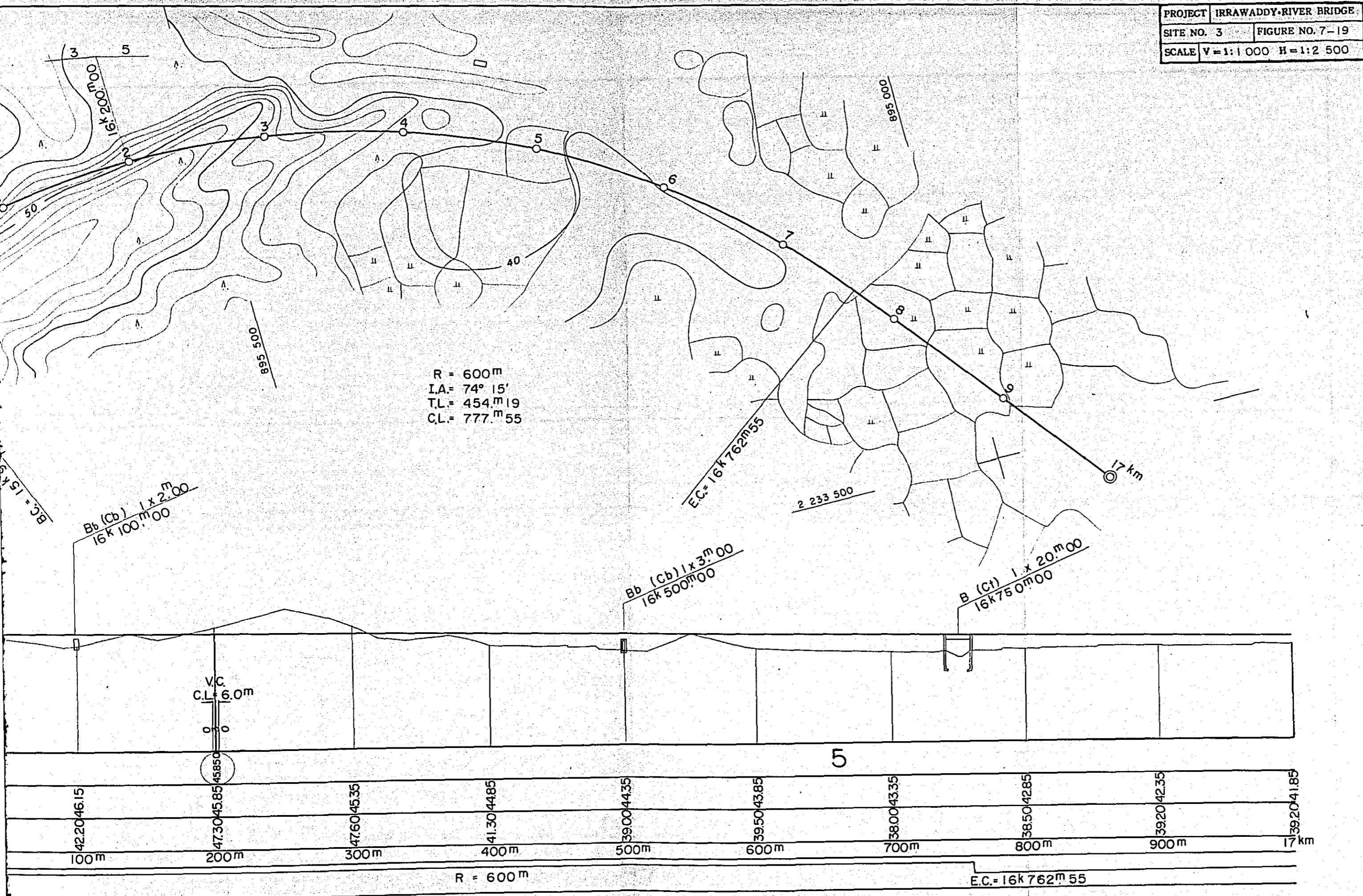

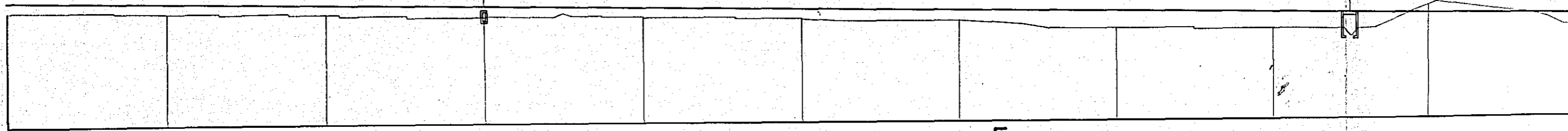
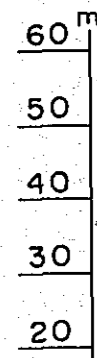
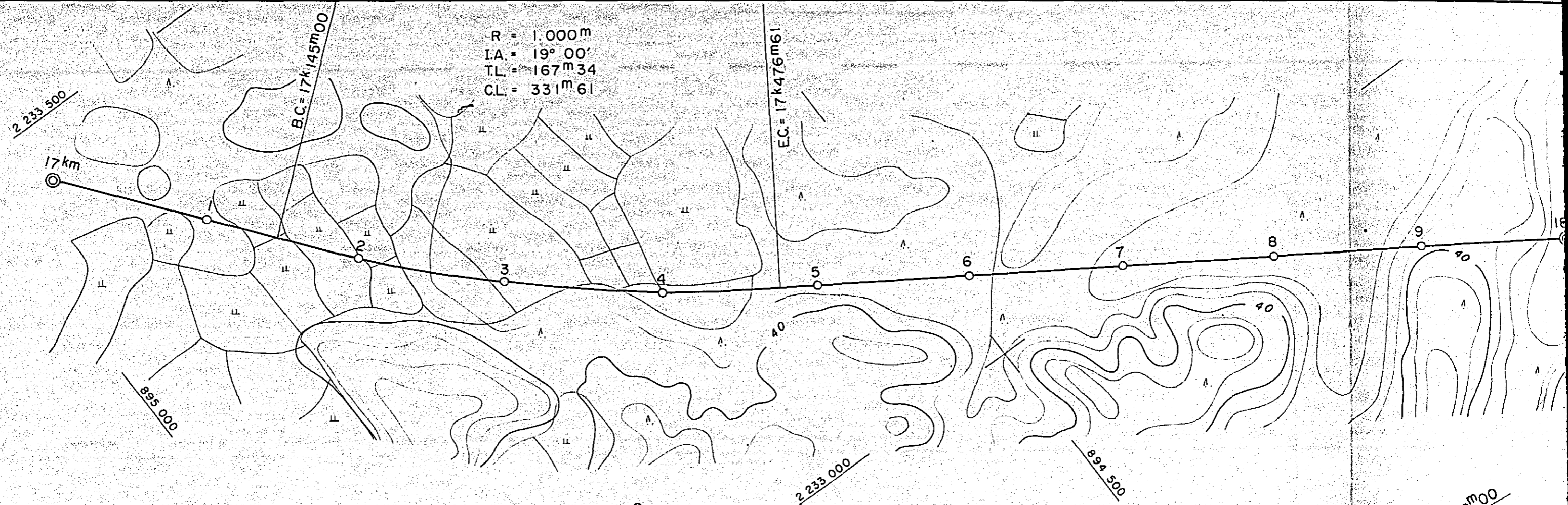

GRADE	%
HEIGHT OF FORMATION	m
HEIGHT OF GROUND	m
KILOMETRAGE	km
CURVE	m

39.20	41.85	38.80	41.35	38.00	40.85	37.20	40.35	37.00	39.85	36.80	39.35	36.00	38.85	33.70	38.35	33.50	37.85	39.00	37.35
17km	100m	200m	300m	400m	500m	600m	700m	800m	900m										
BC = 17k145m00			R = 1.000m				EC = 17k476m61												



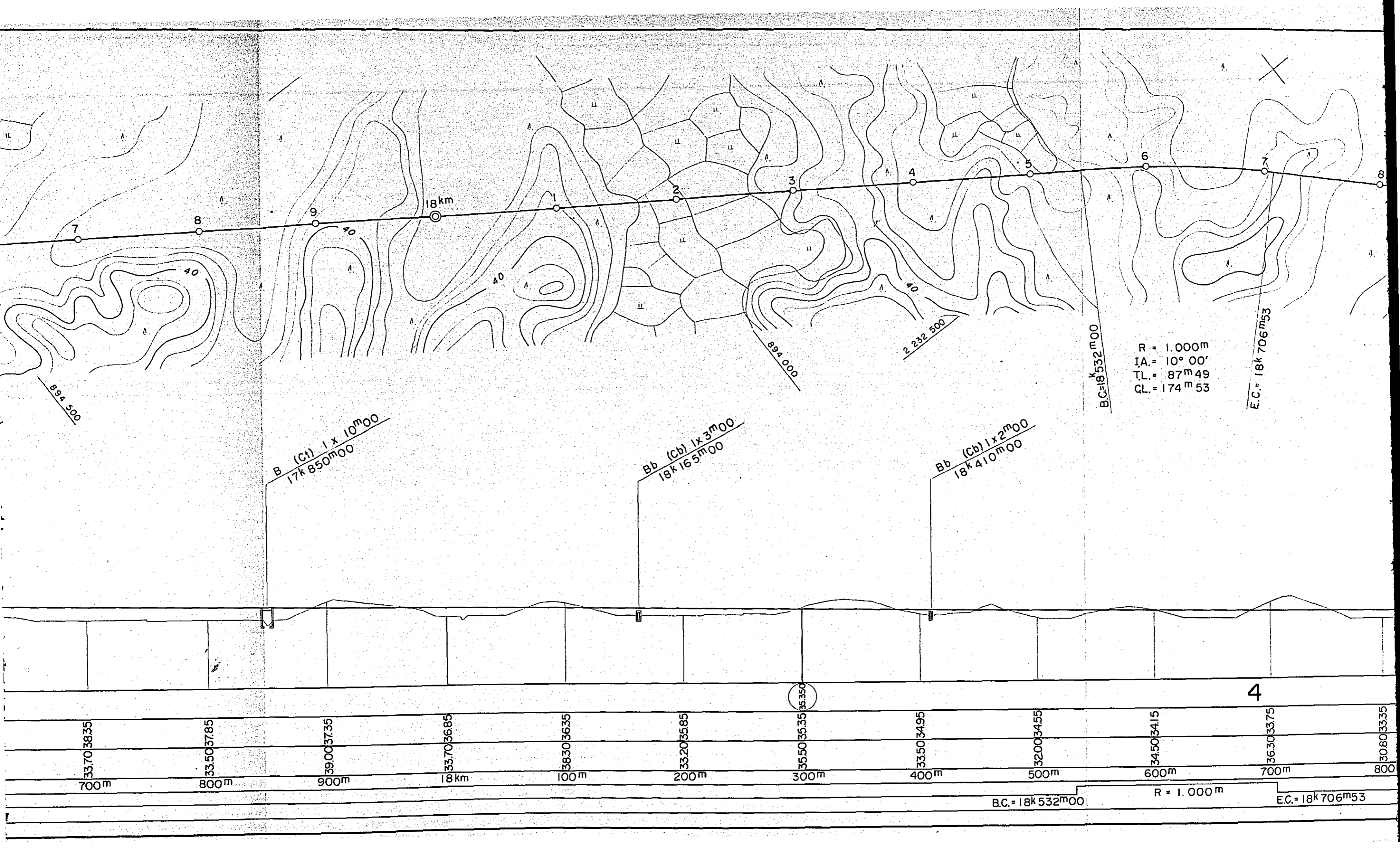

894 500

B (Ct) 1 x 10<sup>m</sup>00  
17k 850<sup>m</sup>00

Bb (Cb) 1 x 3<sup>m</sup>00  
18k 165<sup>m</sup>00

Bb (Cb) 1 x 2<sup>m</sup>00  
18k 410<sup>m</sup>00

B.C. = 18<sup>k</sup> 532<sup>m</sup>00

R = 1.000m  
I.A. = 10° 00'  
T.L. = 87<sup>m</sup> 49  
Q.L. = 174<sup>m</sup> 53

E.C. = 18k 706<sup>m</sup>53

33.70 38.35  
700m

33.50 37.85  
800m

39.00 37.35  
900m

33.70 36.85  
18 km

38.30 36.35  
100m

33.20 35.85  
200m

35.50 35.35 35.350  
300m

33.50 34.95  
400m

32.00 34.55  
500m

34.50 34.15  
600m

36.30 33.75  
700m

30.80 33.35  
800m

B.C. = 18<sup>k</sup> 532<sup>m</sup>00

R = 1.000m

E.C. = 18k 706<sup>m</sup>53

4

PROJECT	IRRAWADDY RIVER BRIDGE
SITE NO.	3
FIGURE NO.	7-20
SCALE	V = 1:1 000 H = 1:2 500

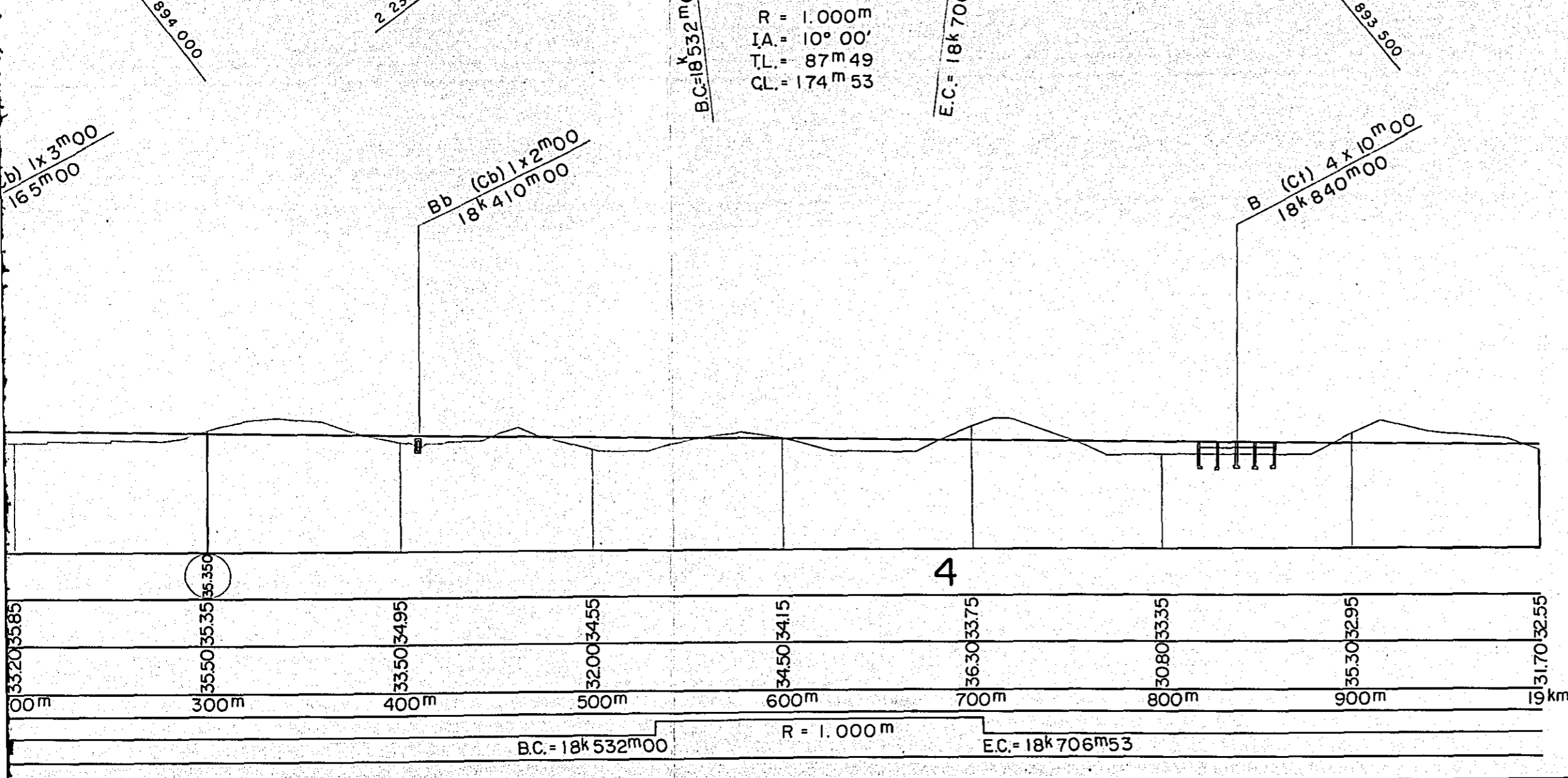
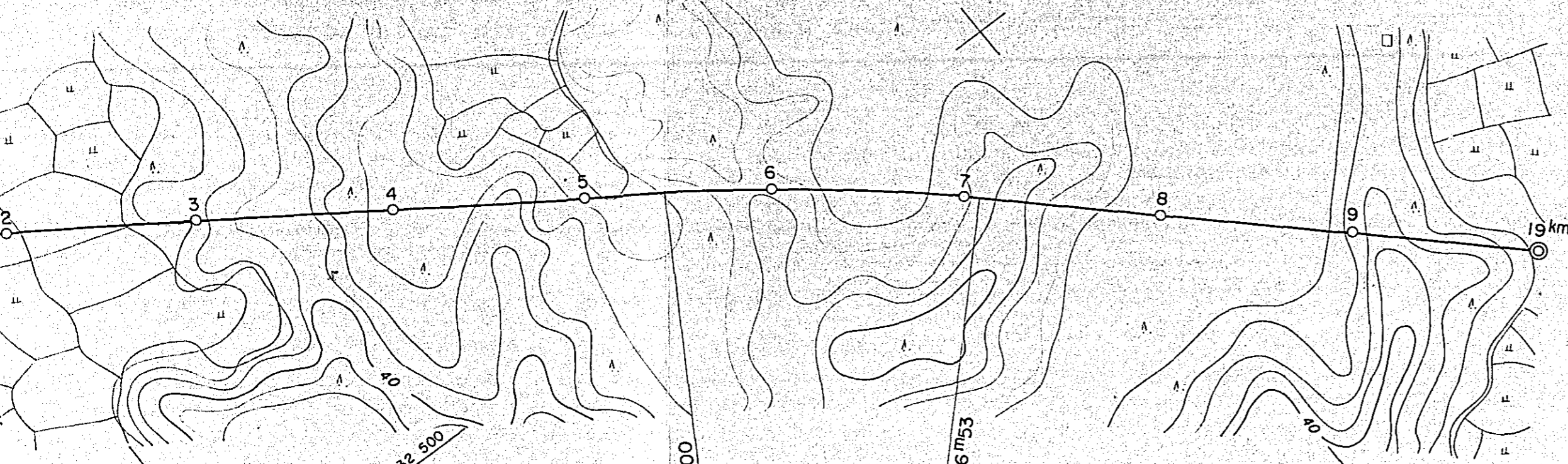



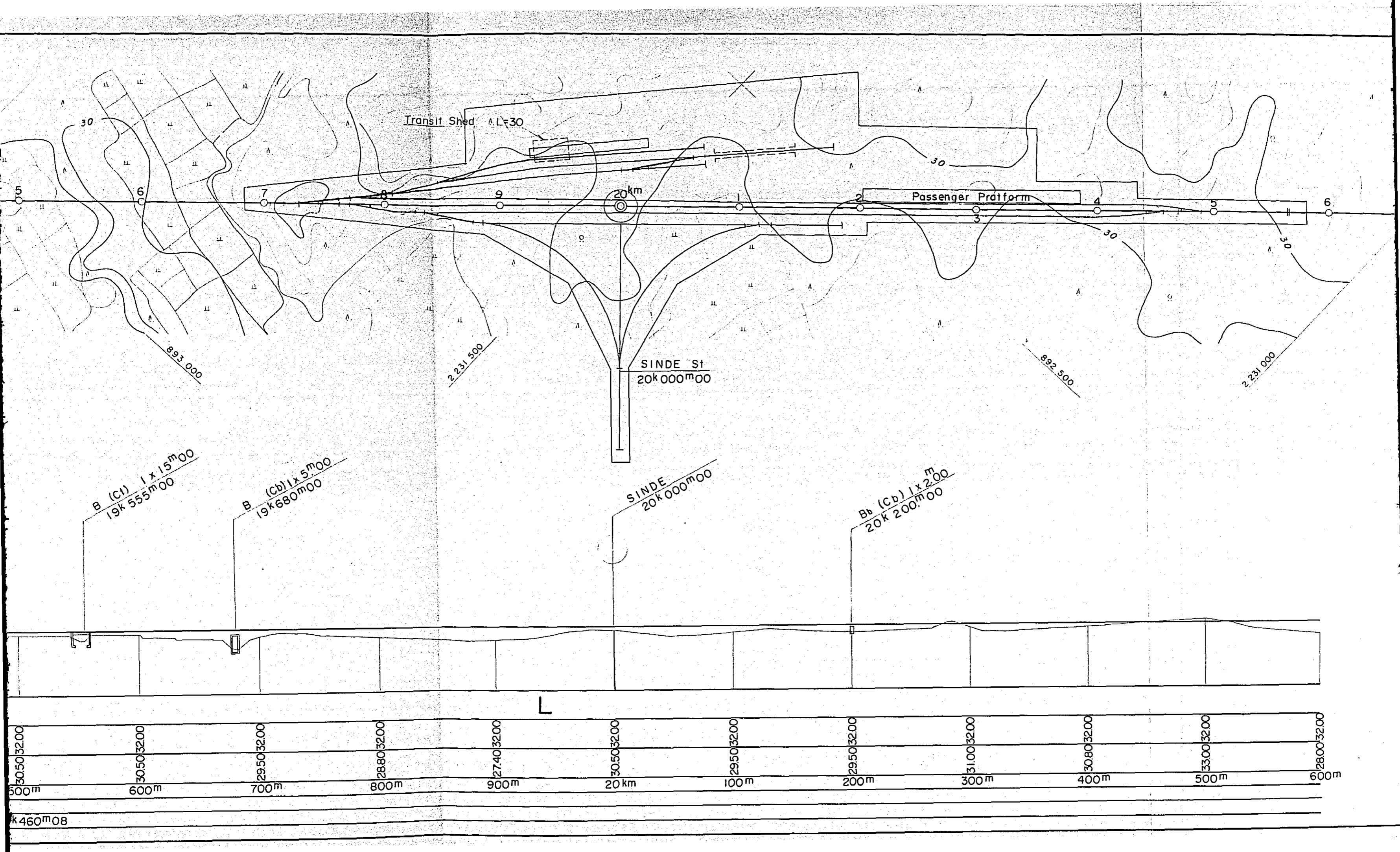

k 460m 08



PROJECT	IRRAWADDY-RIVER BRIDGE	
SITE NO.	3	FIGURE NO. 7-21
SCALE	V = 1:1 000	H = 1:2 500

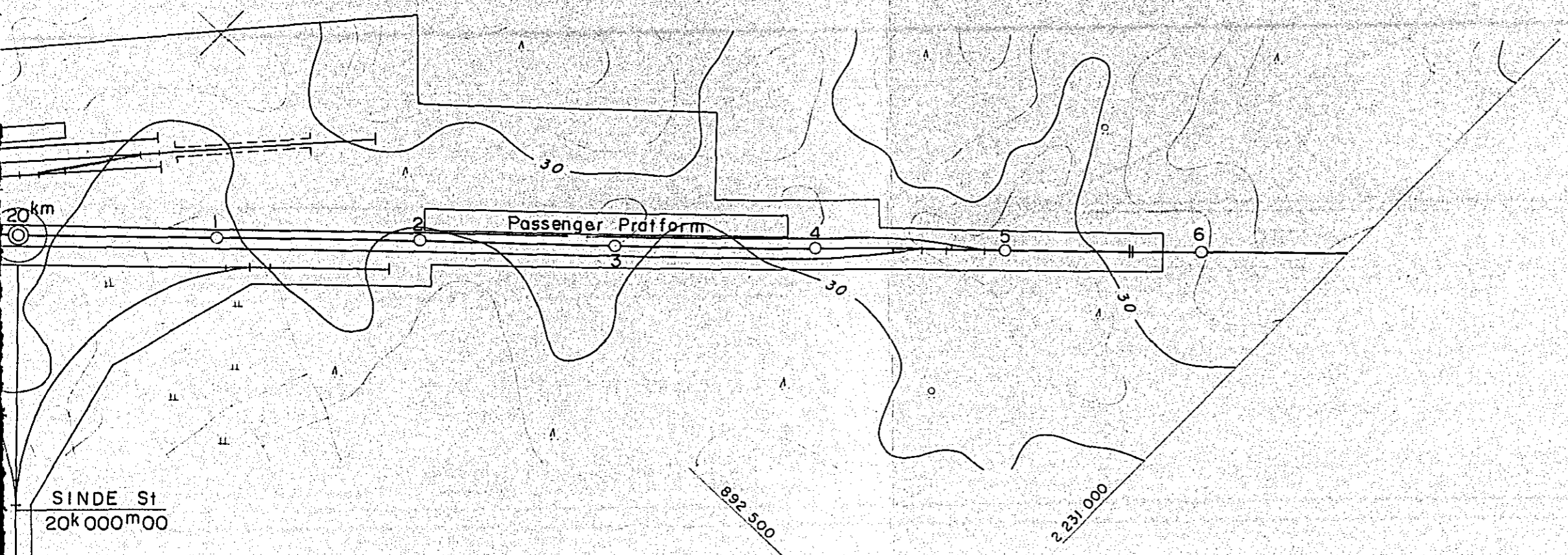

SINDE St  
20k 000m 00

SINDE  
20k 000m 00

Bb (Cb) 1 x 2.00 m  
20k 200m 00

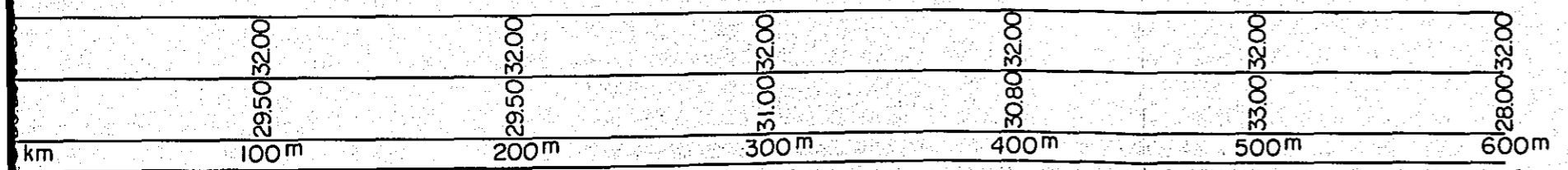
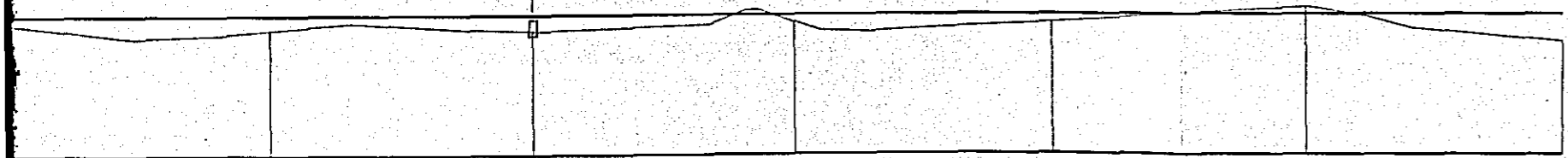



NEW PROME

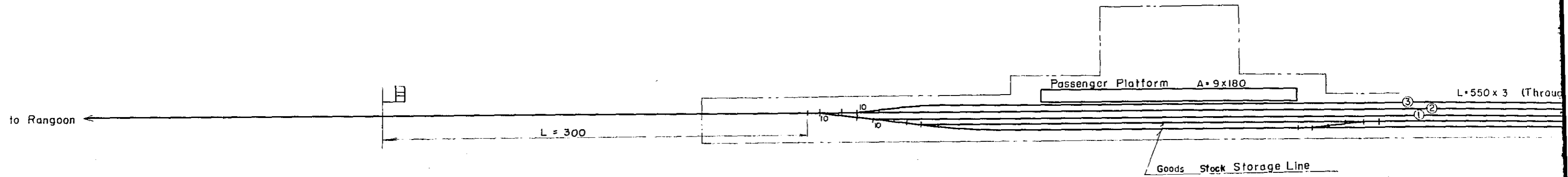

SINDE

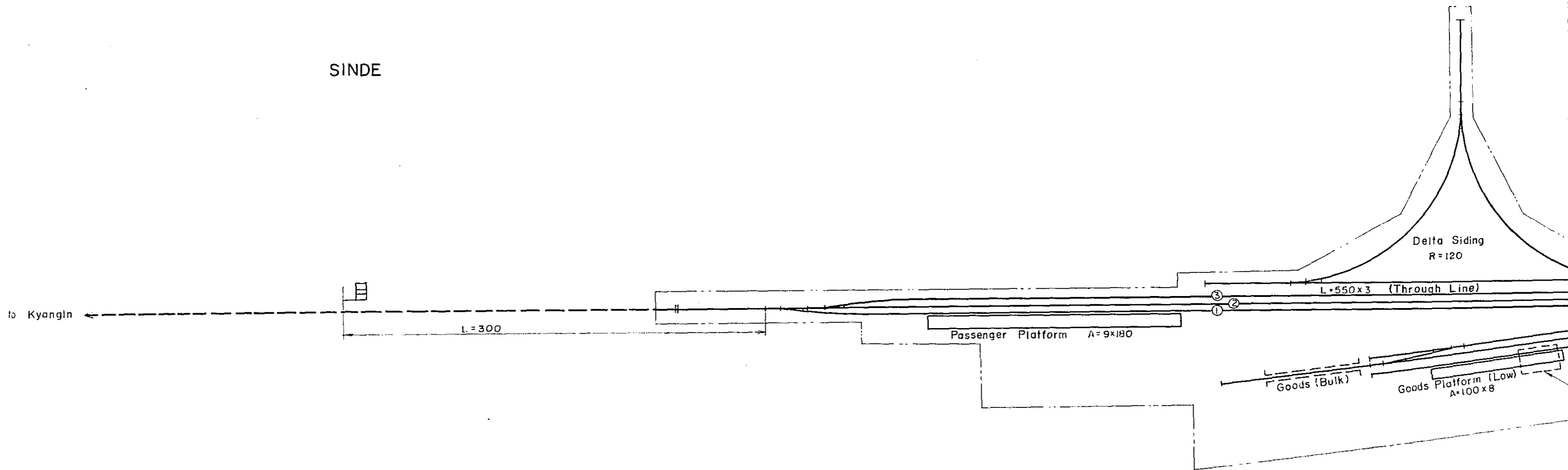

PROJECT	IRRAWADDY RIVER BRIDGE
SITE NO	FIGURE NO 7- 22
SCALE	V = 1. H = 1

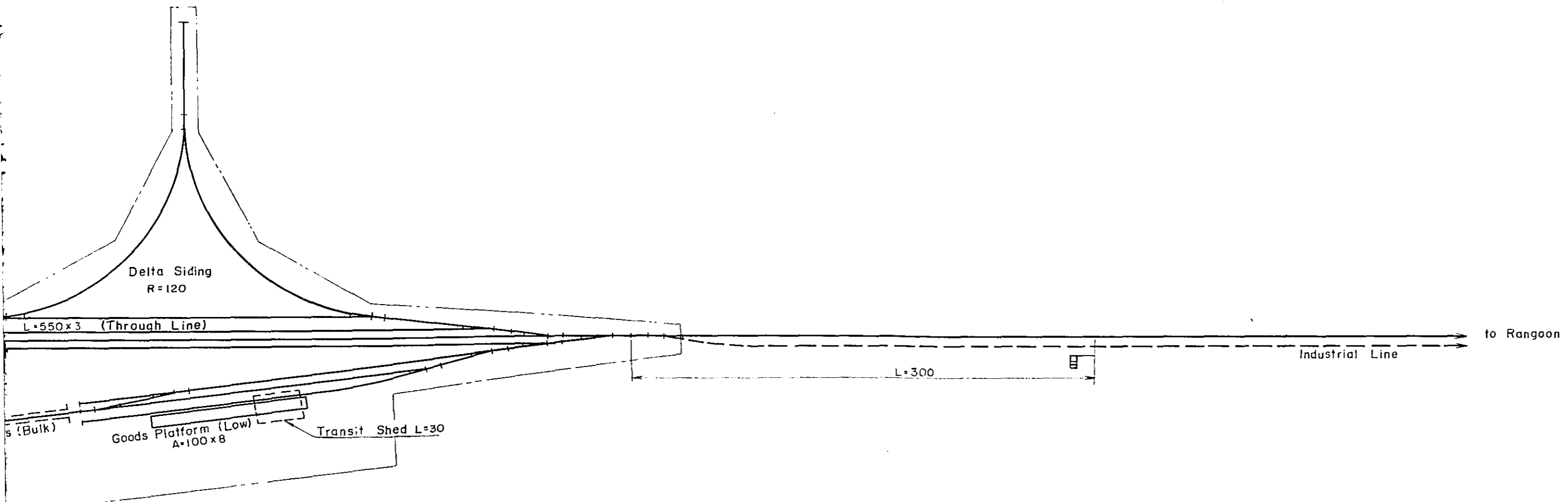
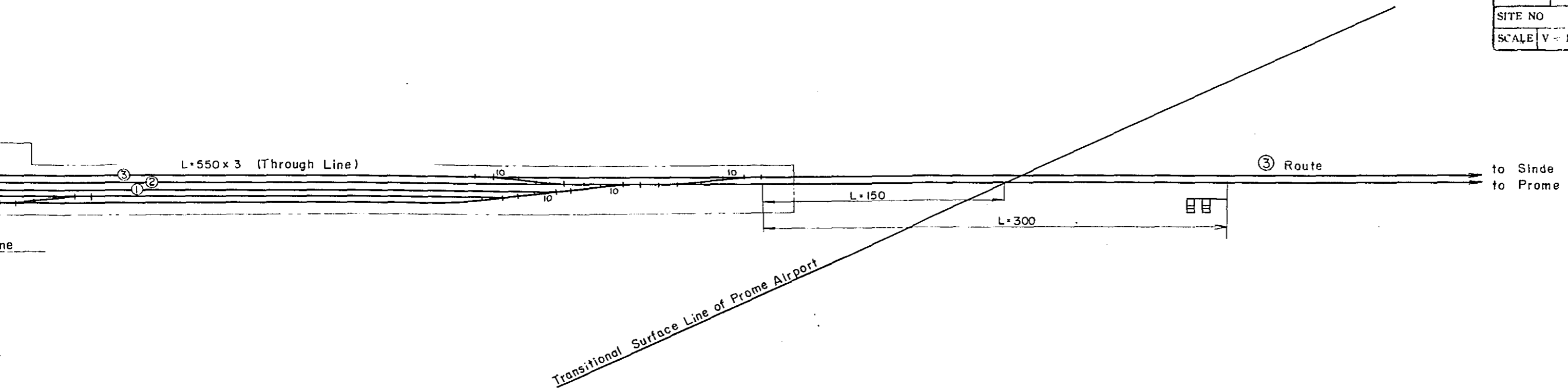

Unit : m

PROJECT	IRRAWADDY RIVER BRIDGE	
SITE NO.	3	FIGURE NO. 7-23
SCALE	V = 1:500	H = 1:500

### NEW PROME STATION

F.L. = 40<sup>m</sup>00      S = 1:500  
 G.H. = 39<sup>m</sup>50

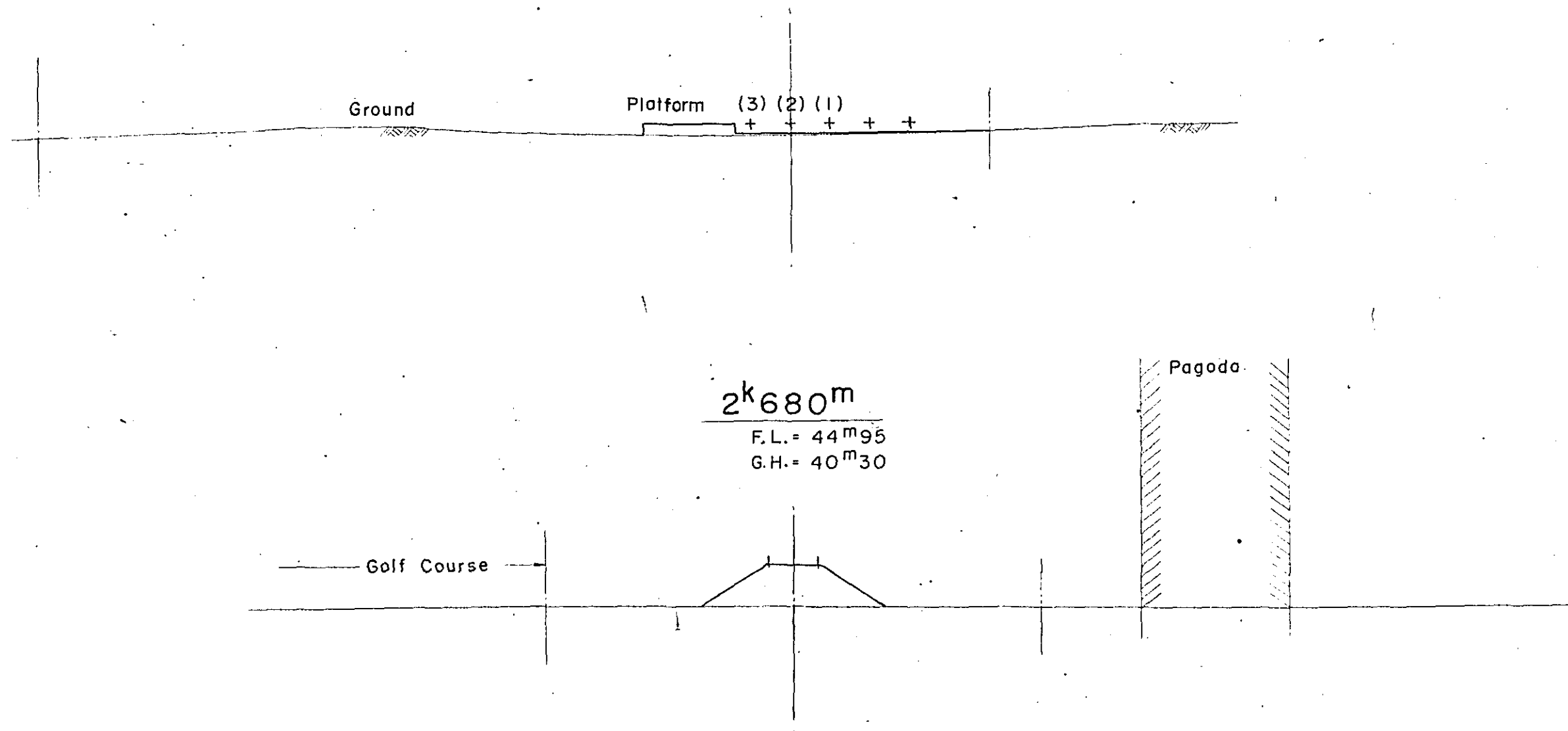

PROJECT	IRRAWADDY RIVER BRIDGE
SITE NO. 3	FIGURE NO. 7-24
SCALE	V = 1:500    H = 1:500

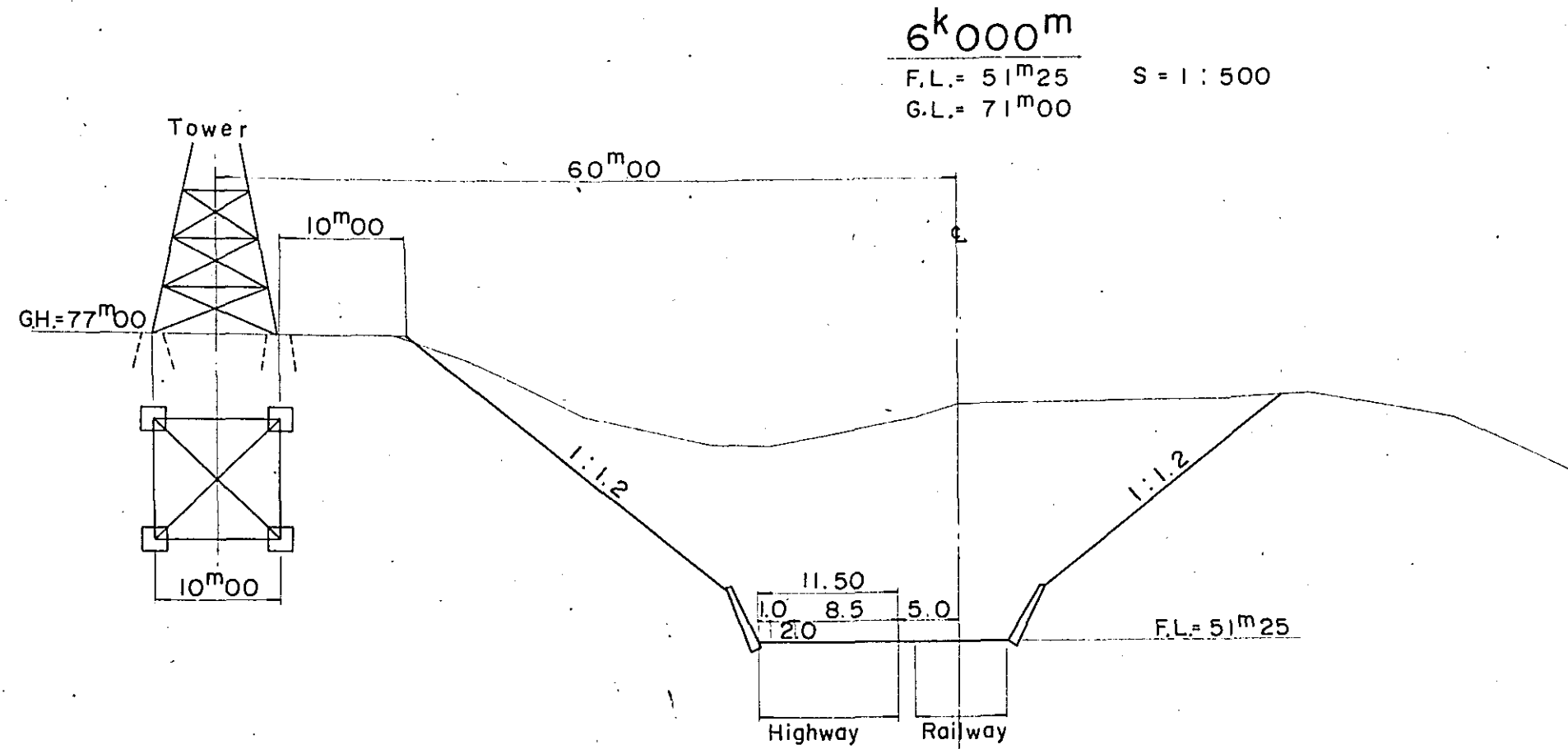

TUNNEL PORTAL  $8^k100^m$   
 F.L. =  $53^m75$   
 G.H. =  $60^m00$

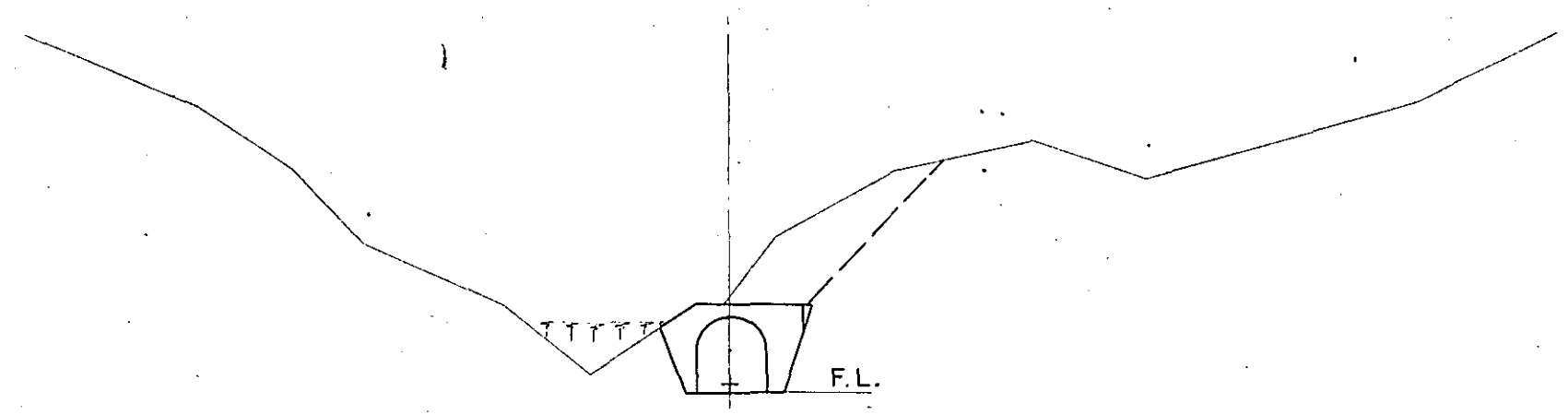

PROJECT	IRRAWADDY-RIVER BRIDGE	
SITE NO. 3	FIGURE NO. 7 - 25	
SCALE	V = 1:500	H = 1:500

$10^k 100^m$   
 F.L. = 63<sup>m</sup>00      S = 1:500  
 G.H. = 66<sup>m</sup>00

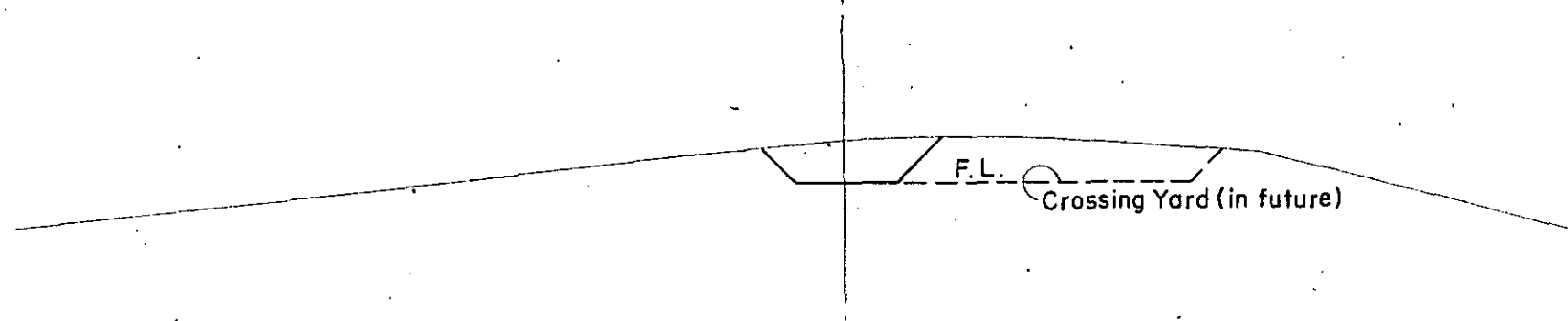

$10^k 800^m$   
 F.L. = 65<sup>m</sup>25  
 G.H. = 80<sup>m</sup>00

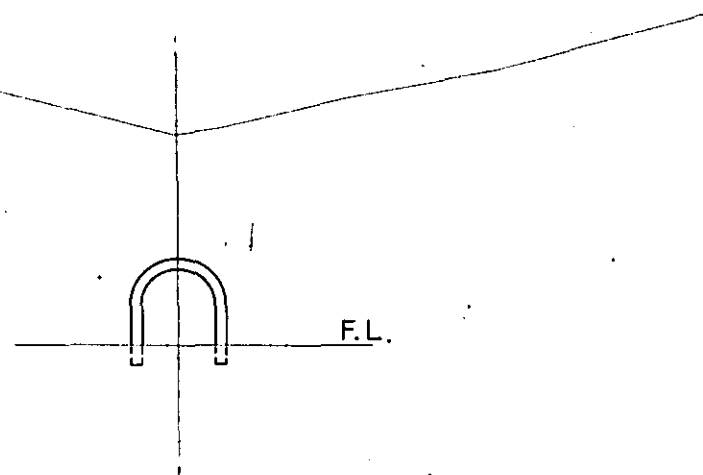



PROJECT	IRRAWADDY RIVER BRIDGE
SITE NO. 3	PLAN NO. 7-26
SCALE	V = 1:500    H = 1:500

12k 000m

F.L. = 65<sup>m</sup>25  
G.H. = 69<sup>m</sup>40

S = 1:500



12k 100m

Access Road (CROSS POINT)

F.L. = 64<sup>m</sup>75  
G.H. = 64<sup>m</sup>00

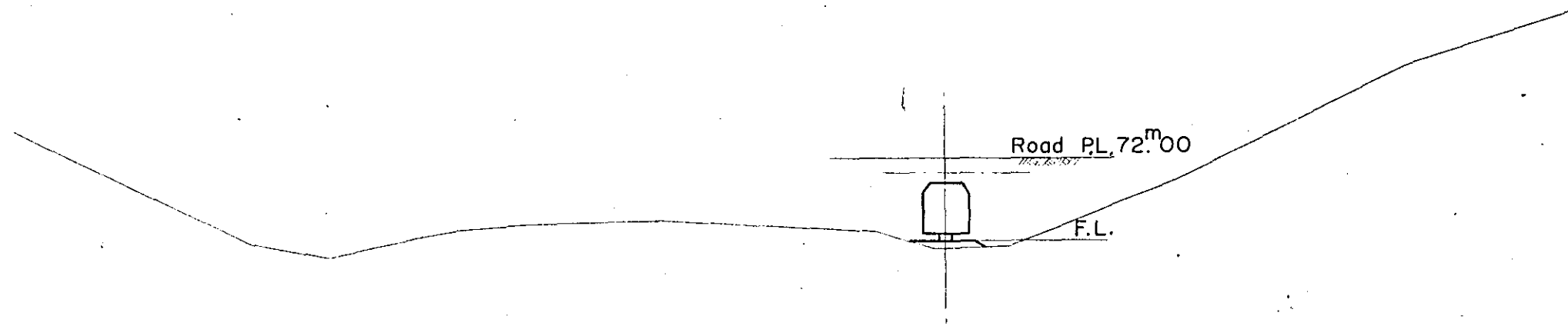

PROJECT	IRRAWADDY-RIVER BRIDGE
SITE NO. 3	LINE NO. 7-27
SCALE	V = 1:500    H = 1:500

SINDE  $20^k000^m00$   
F.L. =  $32^m00$     S = 1:1,000  
G.H. =  $30^m50$

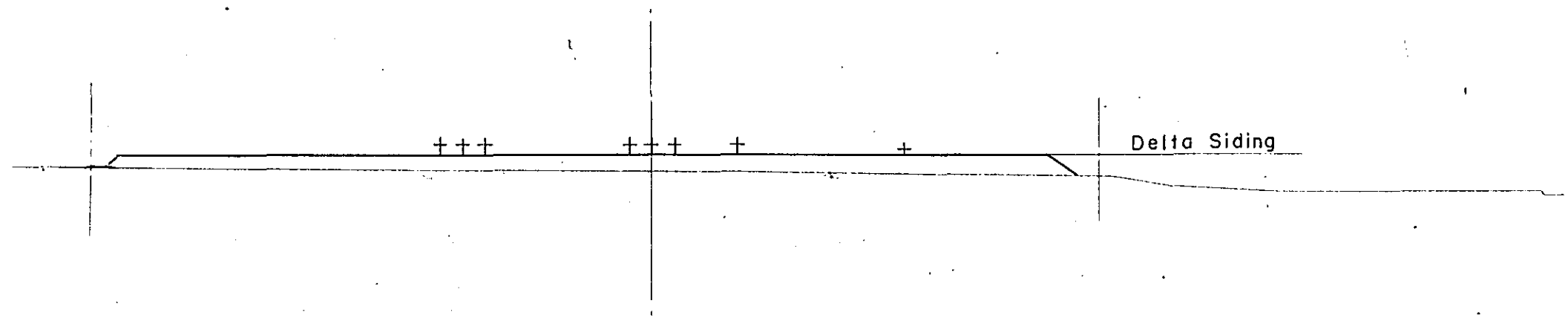



(RAILWAY)

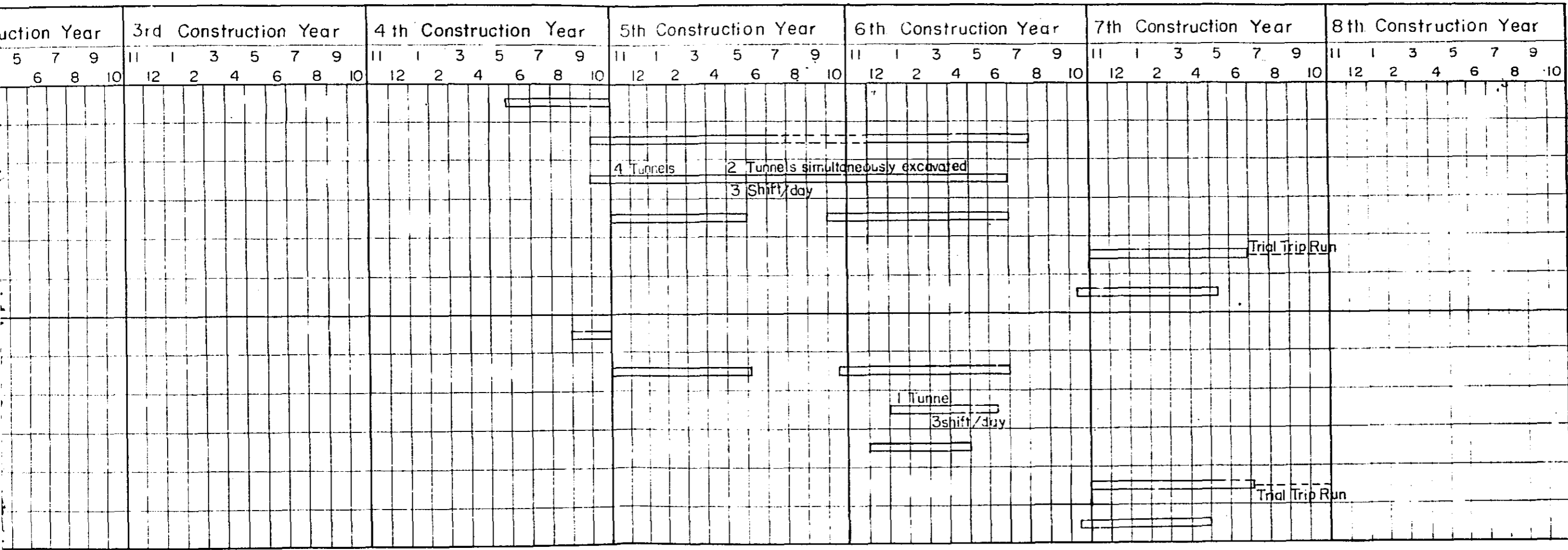

Bulldozer	32T	2	Leg Jumbo	2-boom	4	Batcher Plant	0.6M <sup>3</sup>	3
---	21T	4	Tunnel Shovel	0.2M <sup>3</sup>	4	Agitator Car	g=76cm 3M <sup>3</sup>	3
---	11T	3	Rocker Shovel	RS 85	4	Motor Car D.L.	g=76cm 89 <sup>PS</sup>	4
Tractor Shovel	1.7M <sup>3</sup>	3	Concrete Pump	12M <sup>3</sup> H	3			
Dump Truck	8T	27	Compressor	200PS	1			
Roller	15T	1	---	100PS	7			
Piling Machine	85 <sup>PS</sup>	1	Diesel Locomotive	g=76cm	6			
					8T			

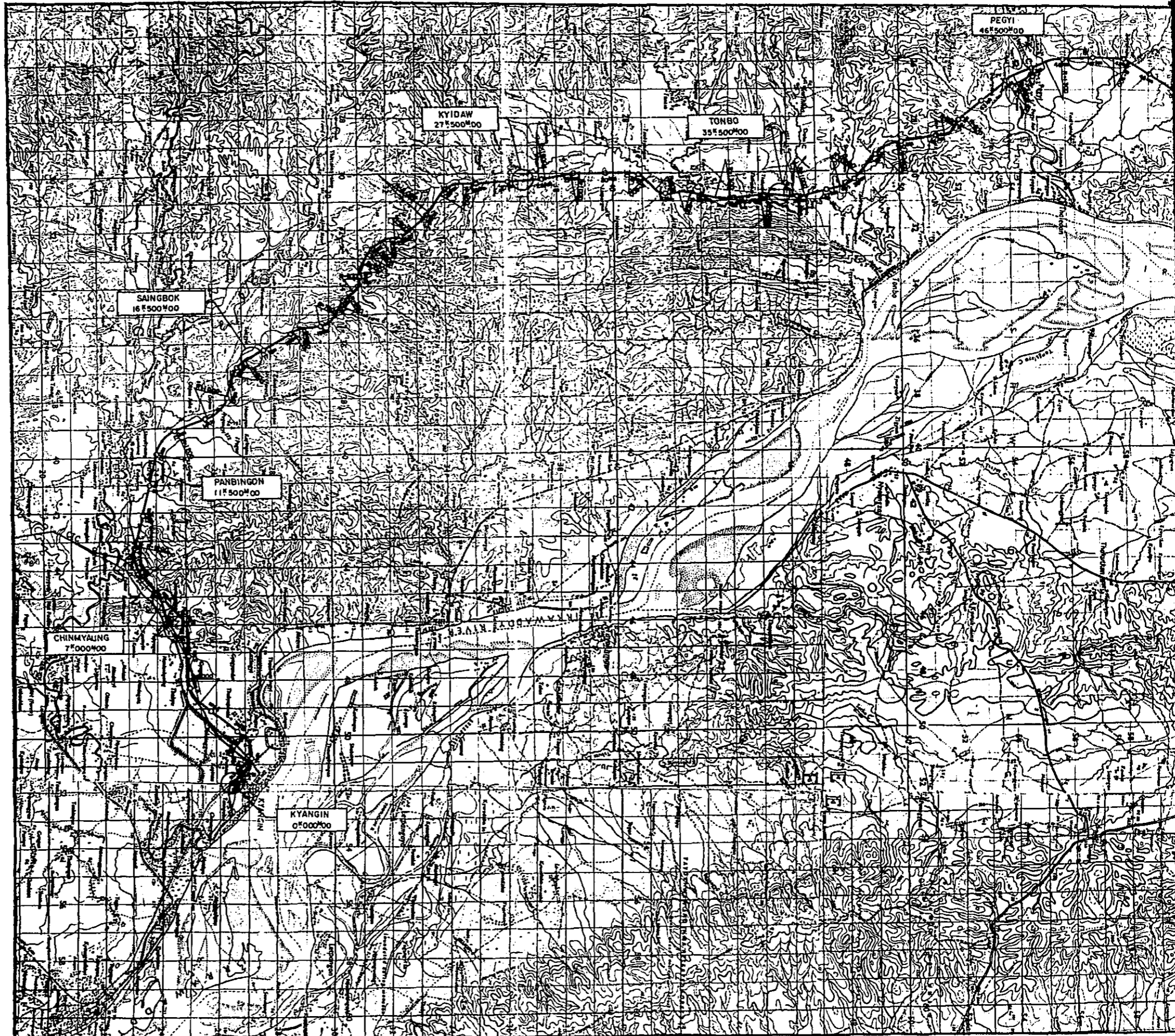



PROJECT IRRAWADDY-RIVER BRIDGE  
SITE NO. FIGURE NO. 7-29  
SCALE V = 1: H = 1:126 720

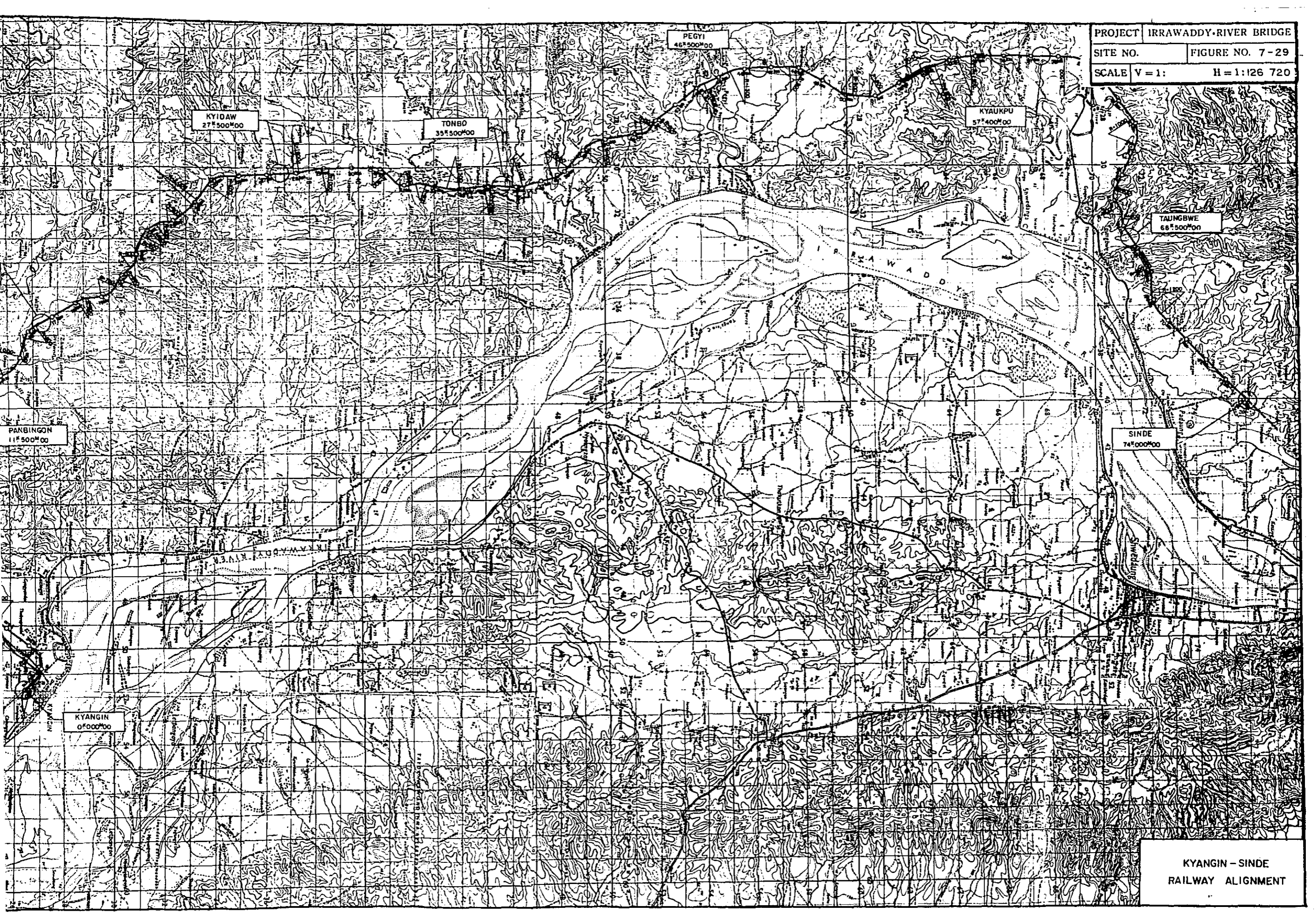

KYANGIN - SINDE  
RAILWAY ALIGNMENT

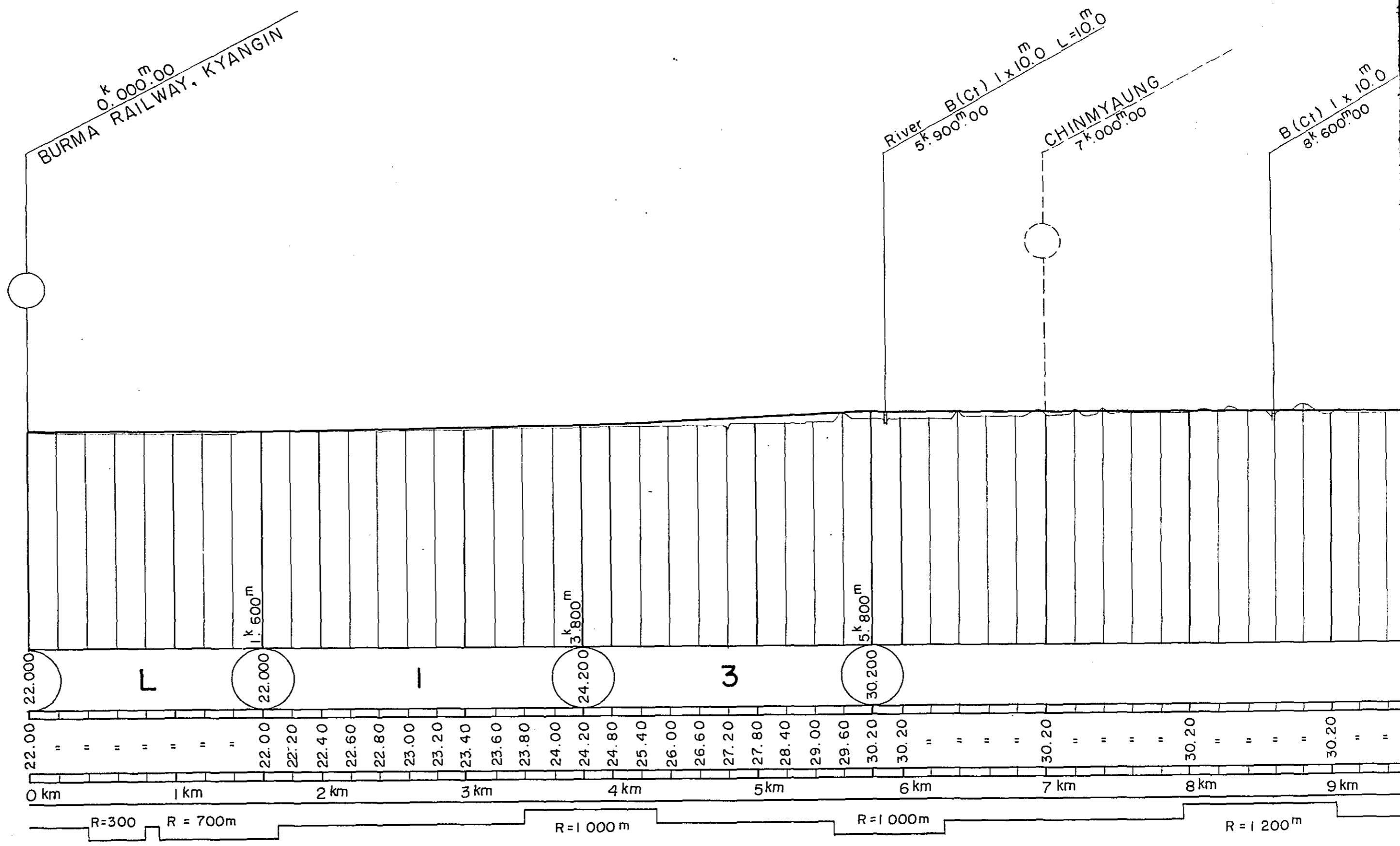

GRADE ‰
HEIGHT OF FORMATION M
KILOMETRAGE
CURVE

22.00	22.00	22.20	22.40	22.60	22.80	23.00	23.20	23.40	23.60	23.80	24.00	24.20	24.40	24.60	24.80	25.00	25.20	25.40	25.60	25.80	26.00	26.20	26.40	26.60	26.80	27.00	27.20	27.40	27.60	27.80	28.00	28.20	28.40	28.60	28.80	29.00	29.20	29.40	29.60	29.80	30.00	30.20	30.40	30.60	30.80	31.00	31.20	31.40	31.60	31.80	32.00	32.20	32.40	32.60	32.80	33.00	33.20	33.40	33.60	33.80	34.00	34.20	34.40	34.60	34.80	35.00	35.20	35.40	35.60	35.80	36.00	36.20	36.40	36.60	36.80	37.00	37.20	37.40	37.60	37.80	38.00	38.20	38.40	38.60	38.80	39.00	39.20	39.40	39.60	39.80	40.00	40.20	40.40	40.60	40.80	41.00	41.20	41.40	41.60	41.80	42.00	42.20	42.40	42.60	42.80	43.00	43.20	43.40	43.60	43.80	44.00	44.20	44.40	44.60	44.80	45.00	45.20	45.40	45.60	45.80	46.00	46.20	46.40	46.60	46.80	47.00	47.20	47.40	47.60	47.80	48.00	48.20	48.40	48.60	48.80	49.00	49.20	49.40	49.60	49.80	50.00	50.20	50.40	50.60	50.80	51.00	51.20	51.40	51.60	51.80	52.00	52.20	52.40	52.60	52.80	53.00	53.20	53.40	53.60	53.80	54.00	54.20	54.40	54.60	54.80	55.00	55.20	55.40	55.60	55.80	56.00	56.20	56.40	56.60	56.80	57.00	57.20	57.40	57.60	57.80	58.00	58.20	58.40	58.60	58.80	59.00	59.20	59.40	59.60	59.80	60.00	60.20	60.40	60.60	60.80	61.00	61.20	61.40	61.60	61.80	62.00	62.20	62.40	62.60	62.80	63.00	63.20	63.40	63.60	63.80	64.00	64.20	64.40	64.60	64.80	65.00	65.20	65.40	65.60	65.80	66.00	66.20	66.40	66.60	66.80	67.00	67.20	67.40	67.60	67.80	68.00	68.20	68.40	68.60	68.80	69.00	69.20	69.40	69.60	69.80	70.00	70.20	70.40	70.60	70.80	71.00	71.20	71.40	71.60	71.80	72.00	72.20	72.40	72.60	72.80	73.00	73.20	73.40	73.60	73.80	74.00	74.20	74.40	74.60	74.80	75.00	75.20	75.40	75.60	75.80	76.00	76.20	76.40	76.60	76.80	77.00	77.20	77.40	77.60	77.80	78.00	78.20	78.40	78.60	78.80	79.00	79.20	79.40	79.60	79.80	80.00	80.20	80.40	80.60	80.80	81.00	81.20	81.40	81.60	81.80	82.00	82.20	82.40	82.60	82.80	83.00	83.20	83.40	83.60	83.80	84.00	84.20	84.40	84.60	84.80	85.00	85.20	85.40	85.60	85.80	86.00	86.20	86.40	86.60	86.80	87.00	87.20	87.40	87.60	87.80	88.00	88.20	88.40	88.60	88.80	89.00	89.20	89.40	89.60	89.80	90.00	90.20	90.40	90.60	90.80	91.00	91.20	91.40	91.60	91.80	92.00	92.20	92.40	92.60	92.80	93.00	93.20	93.40	93.60	93.80	94.00	94.20	94.40	94.60	94.80	95.00	95.20	95.40	95.60	95.80	96.00	96.20	96.40	96.60	96.80	97.00	97.20	97.40	97.60	97.80	98.00	98.20	98.40	98.60	98.80	99.00	99.20	99.40	99.60	99.80	100.00
0 km	1 km	2 km	3 km	4 km	5 km	6 km	7 km	8 km	9 km																																																																																																																																																																																																																																																																																																																																																																																														
$R=300$	$R=700$			$R=1000$		$R=1000$			$R=1200$																																																																																																																																																																																																																																																																																																																																																																																														

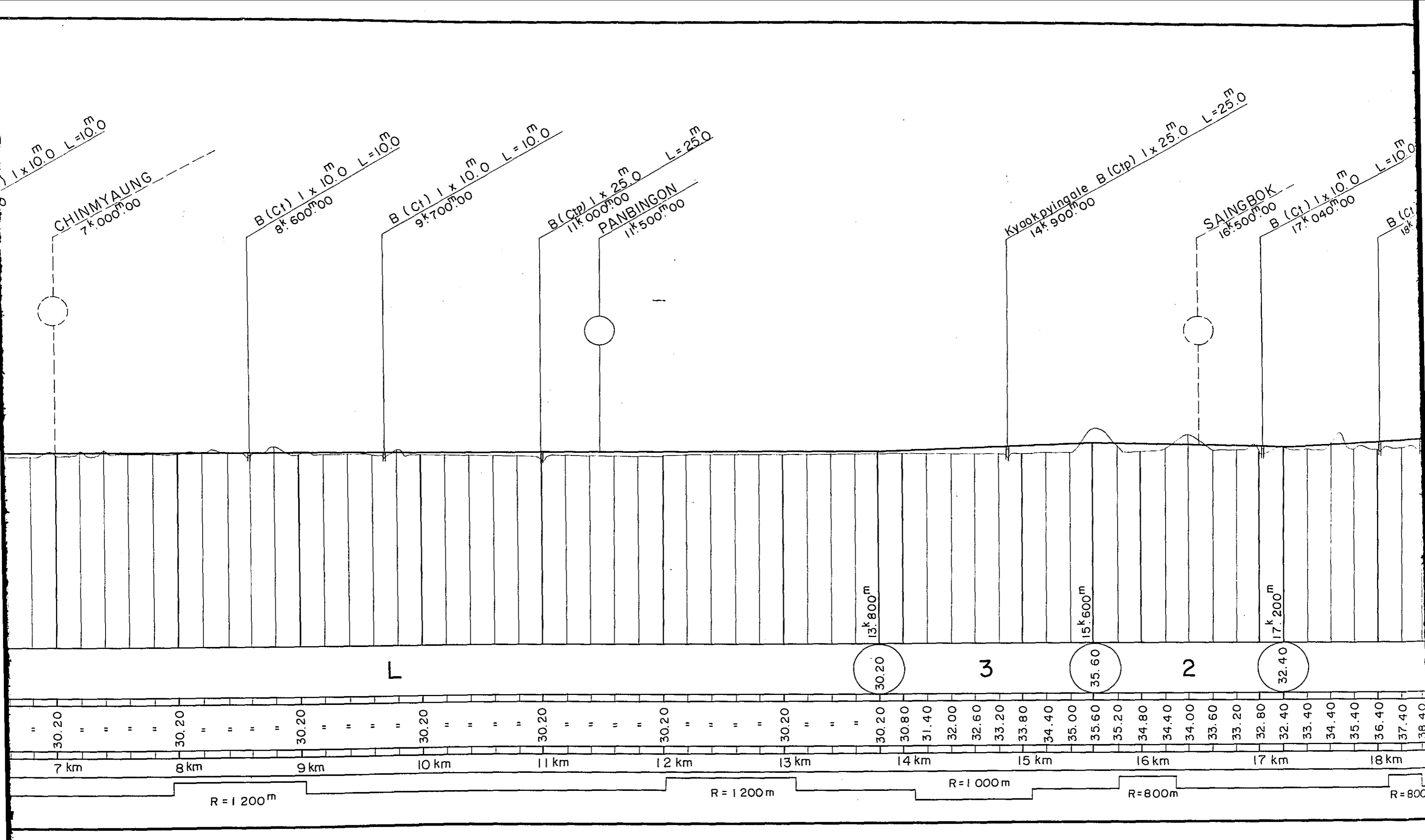

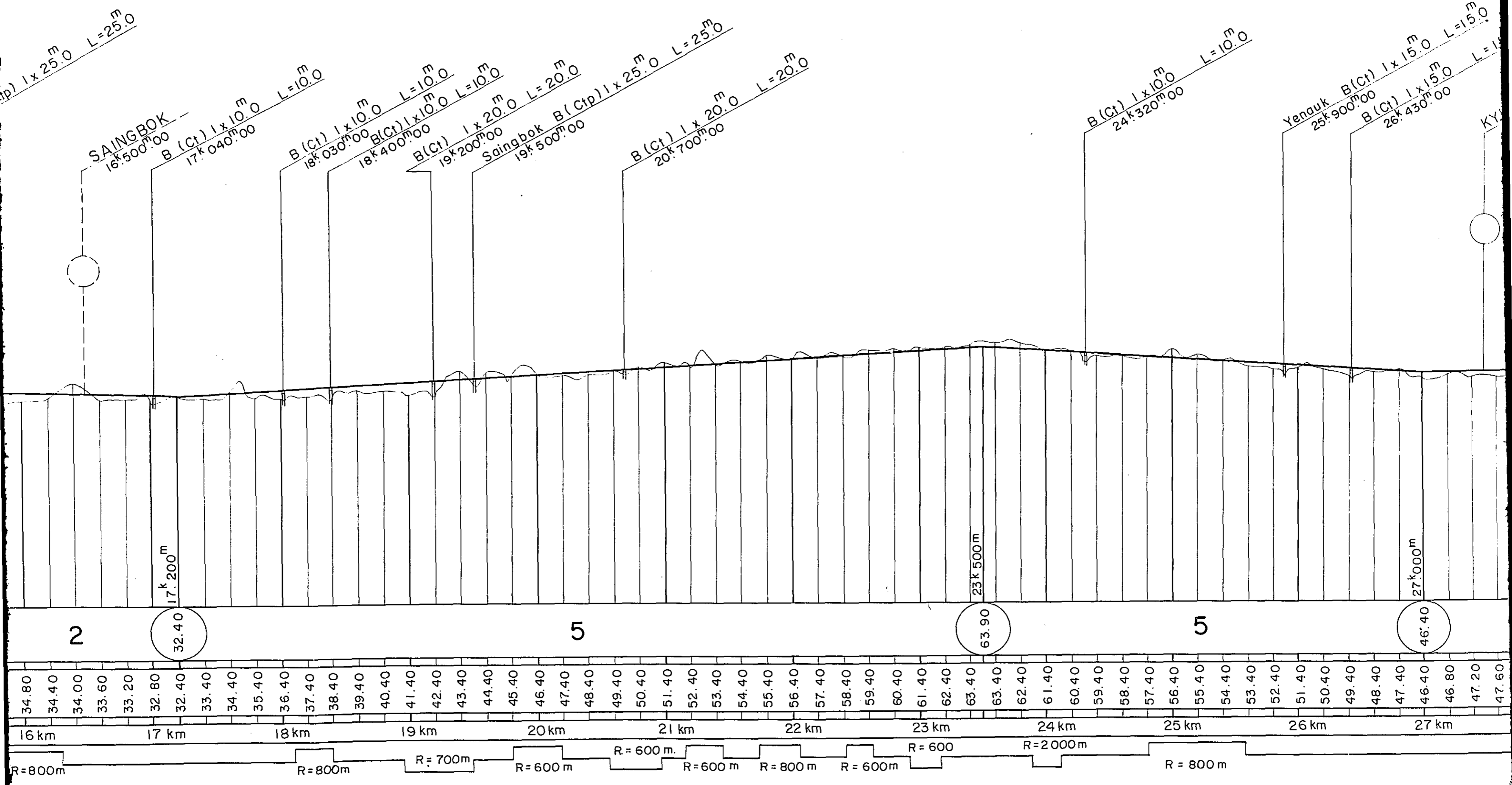

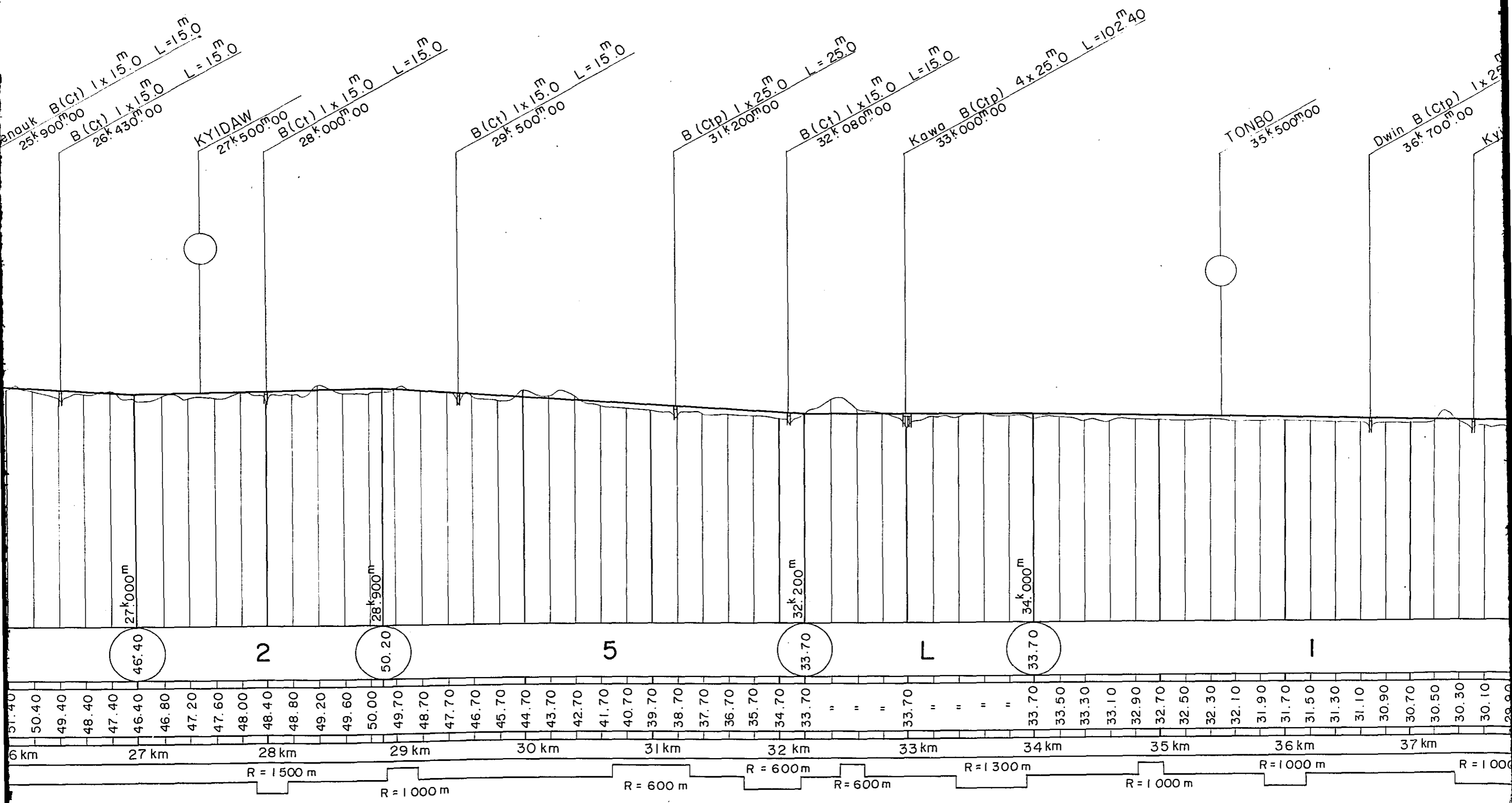



500m.00

Dwin B (Ctp) 1x25.0 m  
36k.700m.00 L=25.0

Kyi B (Ct) 1x20.0 m  
37k.500m.00 L=20.0

R Bv (Ct) 1x20.0 m  
41k.700m.00 L=20.0

B (Ct) 1x20.0 m  
42k.570m.00 L=20.0

B (Ct) 1x10.0 m  
44k.000m L=10.0

B (Ctp) 1x25.0 m  
44k.950m.00 L=25.0

Thaiedan  
45k.400m.00  
B (Ctp) 3 x 25.0 m  
L=76.20

PEGYI  
46k.500m.00  
B (Ct)  
47k.20

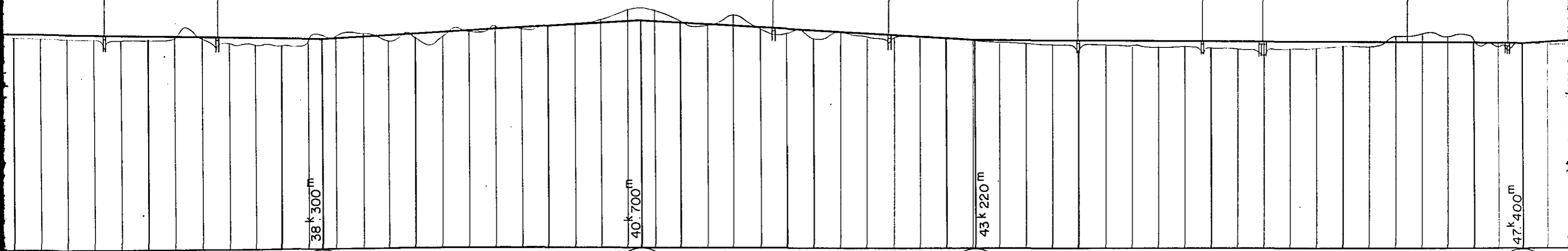

31.70	31.50	31.30	31.10	30.90	30.70	30.50	30.30	30.10	29.90	29.70	29.50	29.85	30.75	31.65	32.55	33.45	34.35	35.25	36.15	37.05	37.95	38.85	39.75	39.70	38.70	37.70	36.70	35.70	34.70	33.70	32.70	31.70	30.70	29.70	28.70	27.70	27.60	"	"	27.60	"	"	"	"	27.60	"	"	"	"	27.60	"	"	27.60	28.40
36 km	37 km				38 km				39 km				40 km				41 km				42 km				43 km				44 km				45 km				46 km				47 km													

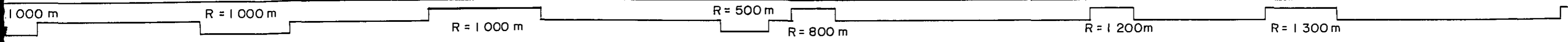

$L = 25.0^m$   
 $B(Ctp) 3 \times 25.0^m$   $L = 76.20^m$   
 PEGYI  
 $46^k 500^m 00$

$B(Ct) 1 \times 10.0^m$   $L = 10.0^m$   
 $47^k 280^m 00$   
 $B(Ct) 1 \times 10.0^m$   $L = 10.0^m$   
 $47^k 800^m 00$   
 $B(Ct) 2 \times 20.0^m$   $L = 10.0^m$   
 $48^k 270^m 00$

$R Bv(Ct) 1 \times 20.0^m$   $L = 40.80^m$   
 $48^k 850^m 00$

$B(Ctp) 2 \times 25.0^m$   $L = 50.80^m$   
 $50^k 450^m 00$

$T. L = 1200^m$   
 $52^k 100^m 00$

$B(Ct) 1 \times 10.0^m$   $L = 10.0^m$   
 $54^k 000^m 00$   
 $B(Ct) 1 \times 10.0^m$   $L = 10.0^m$   
 $54^k 400^m 00$   
 $B(Ct) 1 \times 10.0^m$   $L = 10.0^m$   
 $54^k 800^m 00$   
 $T. L = 230.0^m$   
 $55^k 000^m 00$

$Kyauk pu B(Ctp) 5 \times 25.0^m$   $L = 125.0^m$   
 $55^k 680^m 00$

$KYA$

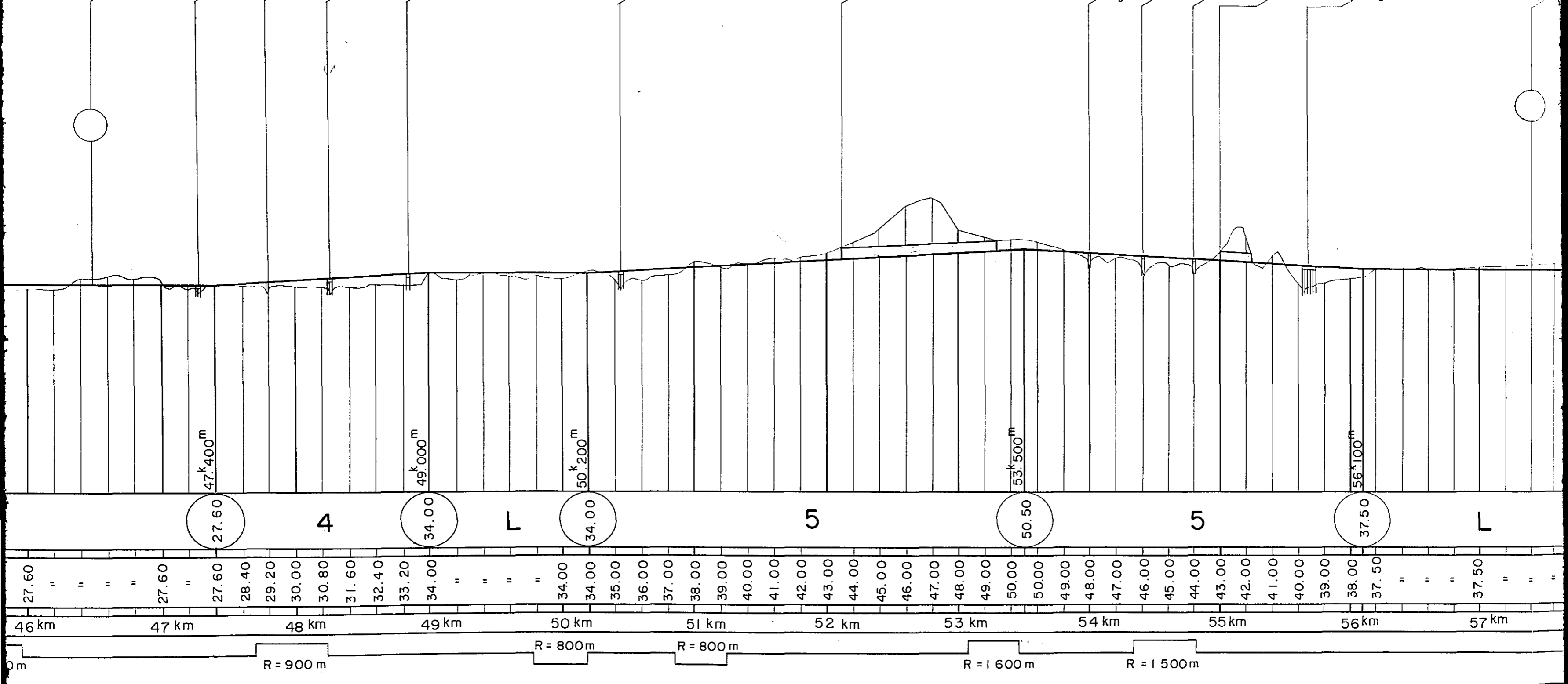

$L=10.0$   
 $1 \times 10.0$   
 $L=230.0$   
 $55^k 000^m 00$   
 Kyaukpu B(Ctp)  $5 \times 25.0$   $L=128.20$   
 $57^k 400^m 00$

B(Ct)  $1 \times 15.0$   $L=15.0$   
 $58^k 300^m 00$

Buyo B(Ctp)  $7 \times 25.0$   $L=179.80$   
 $60^k 100^m 00$

B(Ct)  $1 \times 10.0$   $L=10.0$   
 $61^k 350^m 00$

B(Ct)  $1 \times 10.0$   $L=10.0$   
 $62^k 000^m 00$

B(Ct)  $1 \times 10.0$   $L=10.0$   
 $62^k 430^m 00$

TAUNGBWE  
 $66^k 500^m 00$   
 B(Ct)

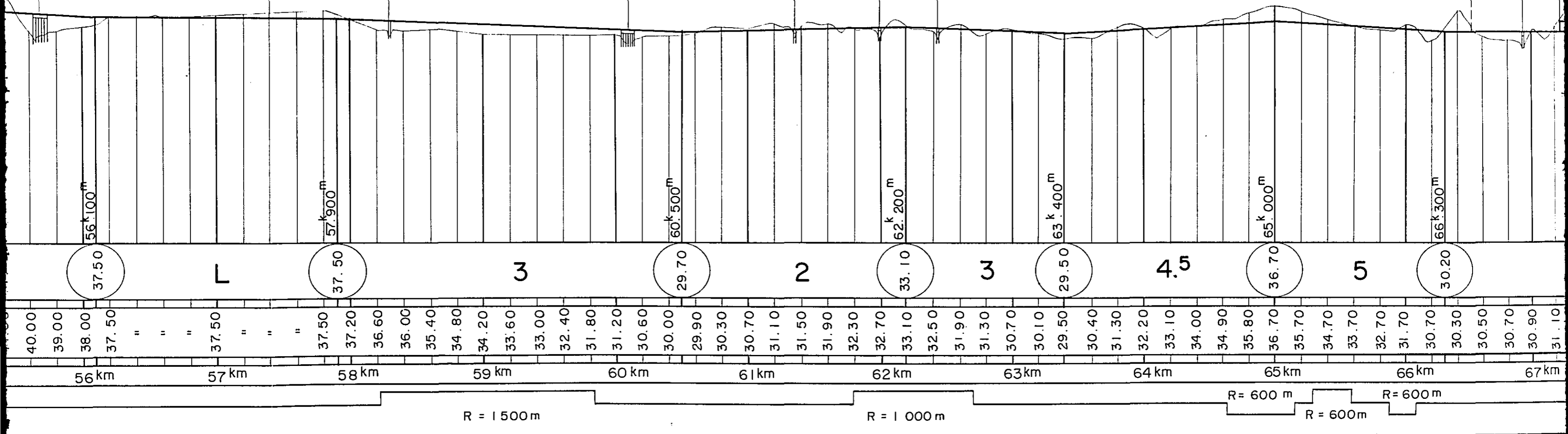

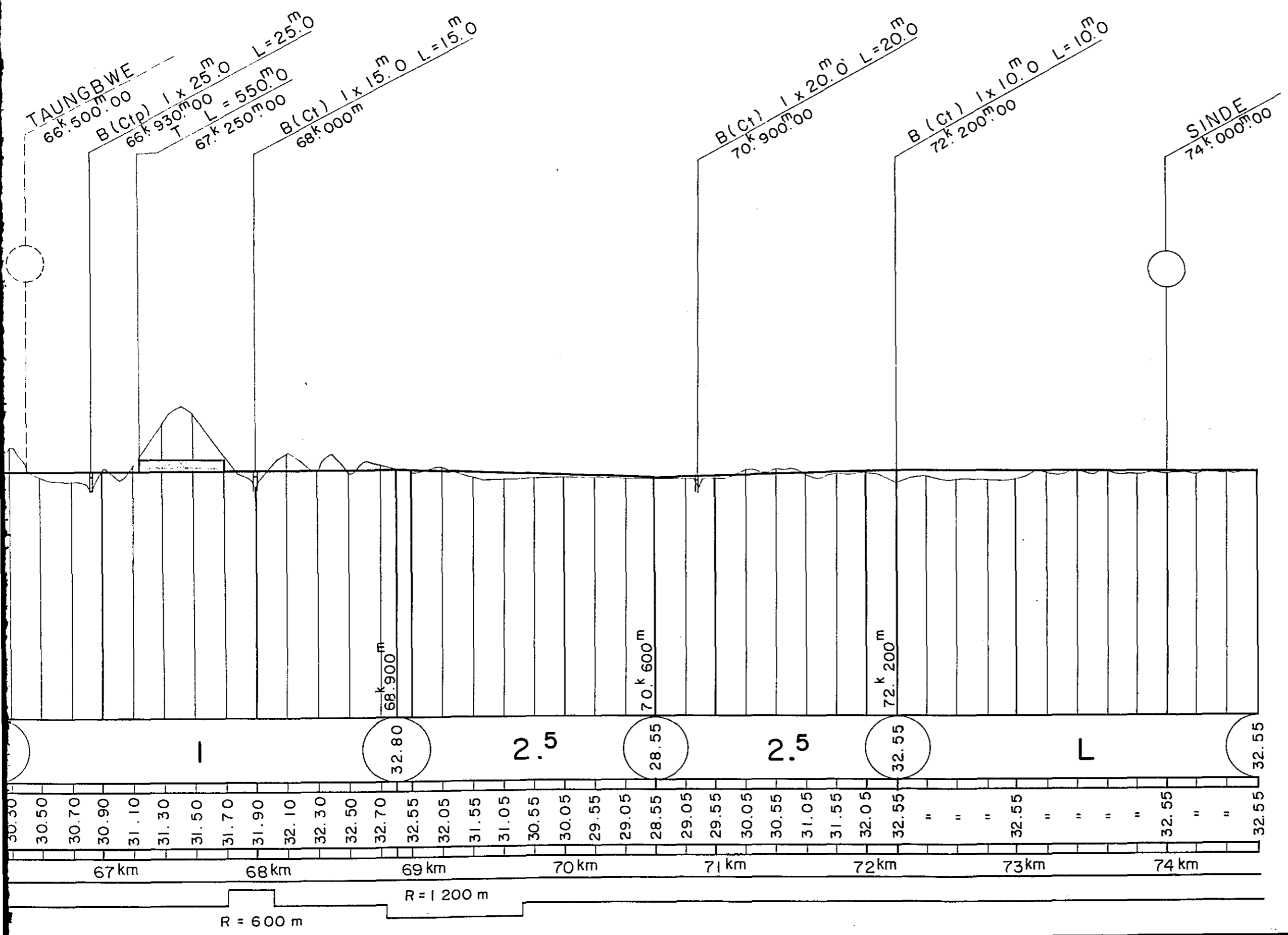

KYANGIN - SINDE  
RAILWAY  
(PROFILE)





PROJECT	IRRAWADDY RIVER BRIDGE
SITE NO.	FIGURE NO 7-31
SCALE	V - 1 H - 1

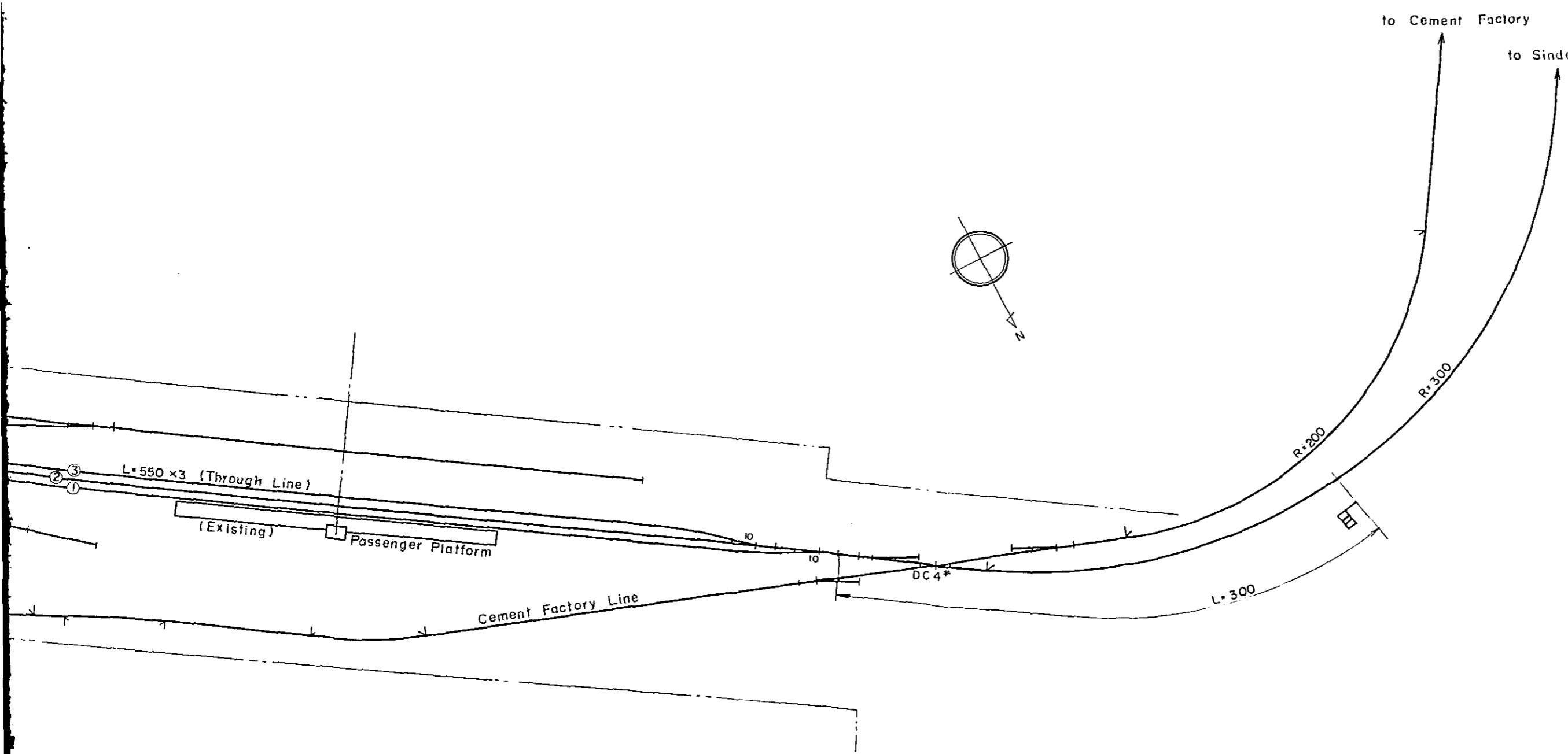
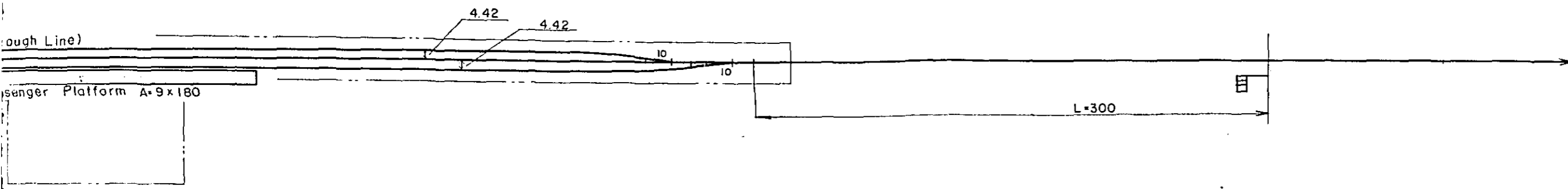

Unit : m

Fig. 7-33 SIGNAL LAYOUT

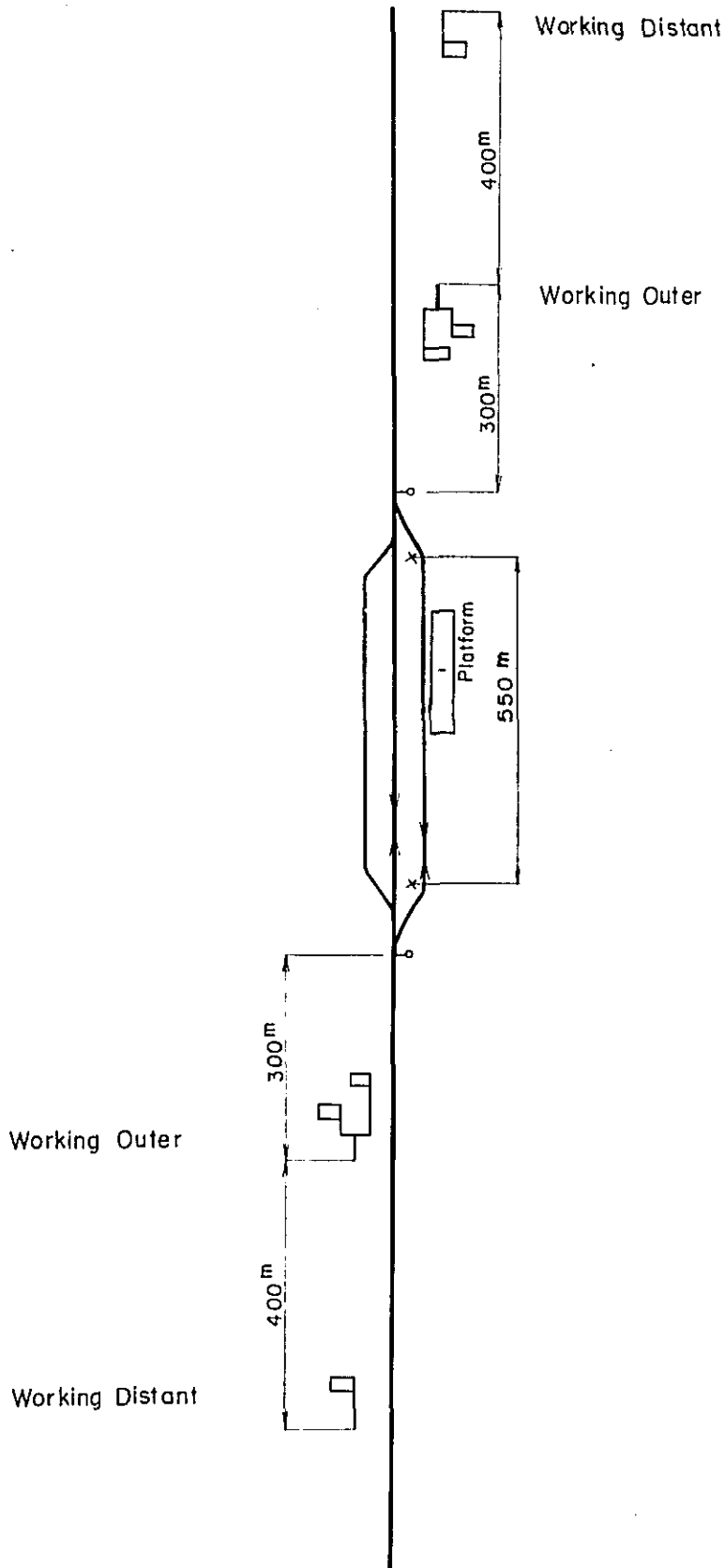

## CHAPTER 8

- Fig. 8-3            Prestressed Concrete Highway-Railway Bridge at Site No. 3
- Fig. 8-4            Steel Highway-Railway Bridge at Site No. 3
- Fig. 8-5            Prestressed Concrete Highway Bridge and Railway Bridge  
                     Separately Constructed on Same Substructure at Site No. 3
- Fig. 8-6            Steel Highway Bridge and Railway Bridge Separately  
                     Constructed on Same Substructure at Site No. 3
- Fig. 8-7            Prestressed Concrete Highway-Railway Bridge at Site No. 1
- Fig. 8-8            Steel Highway-Railway Bridge at Site No. 1
- Fig. 8-9            Prestressed Concrete Highway-Railway Bridge at Site No. 2
- Fig. 8-10           Steel Highway-Railway Bridge at Site No. 2
- Fig. 8-11-1        General Sequence of Building Steel Pile Foundation and  
                     Pneumatic Caisson
- Fig. 8-11-2        Continued
- Fig. 8-12           Construction Schedule for Prestressed Concrete Highway-  
                     Railway Bridge at Site No. 3
- Fig. 8-13           Construction Schedule for Steel Highway-Railway Bridge  
                     at Site No. 3

PRESTRESSED CONCRETE HIGHWAY

SIDE EL

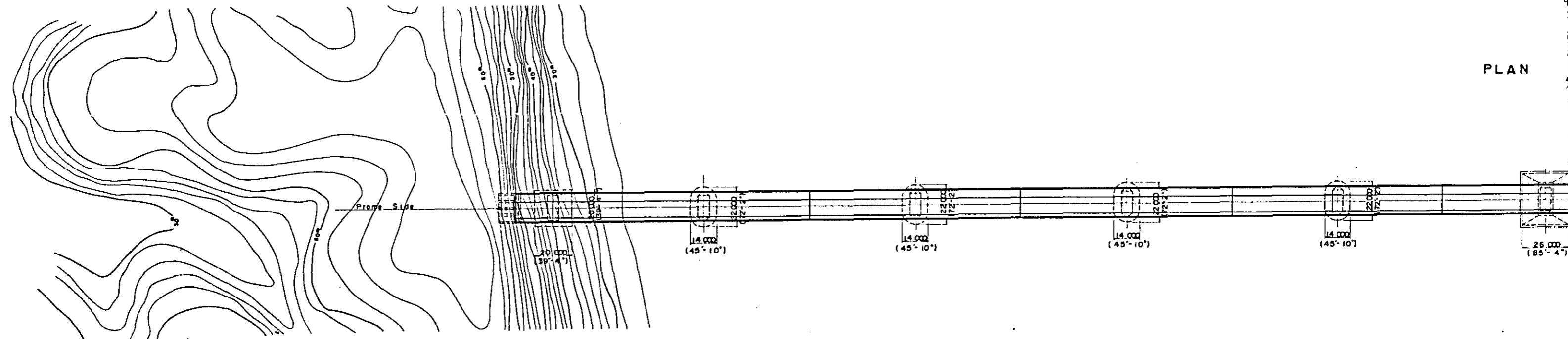
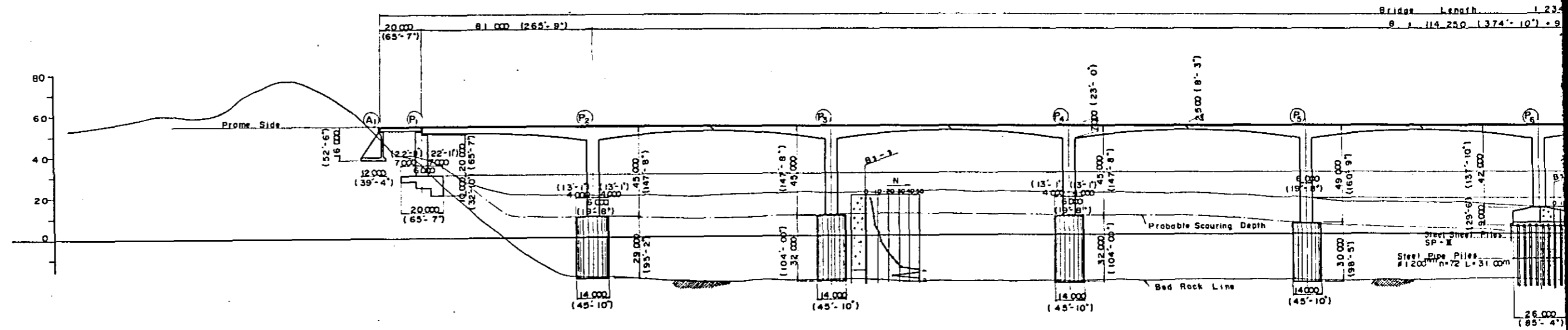

PLAN

# PRESTRESSED CONCRETE HIGHWAY—RAILWAY BRIDGE AT SITE NO.3

## SIDE ELEVATION

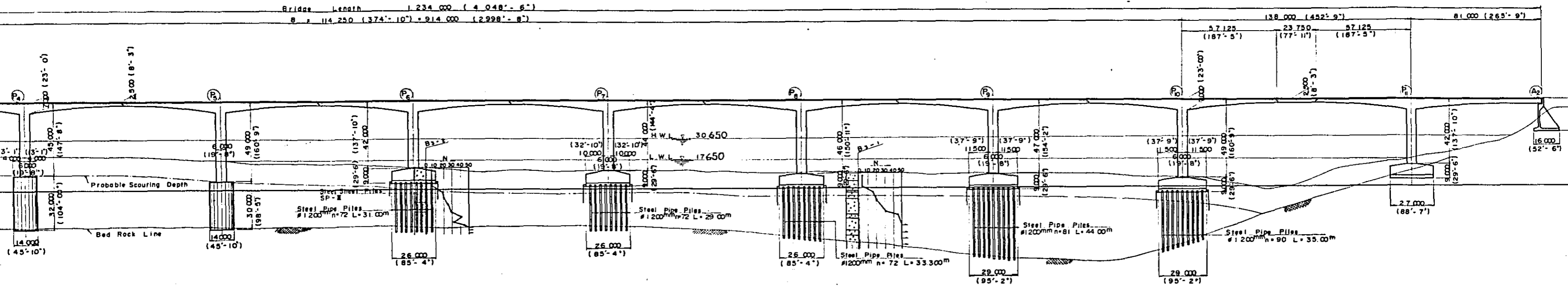

## PLAN

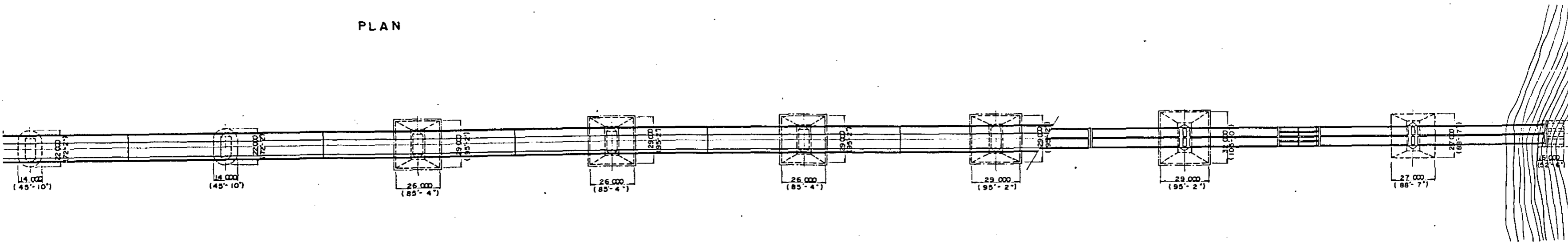



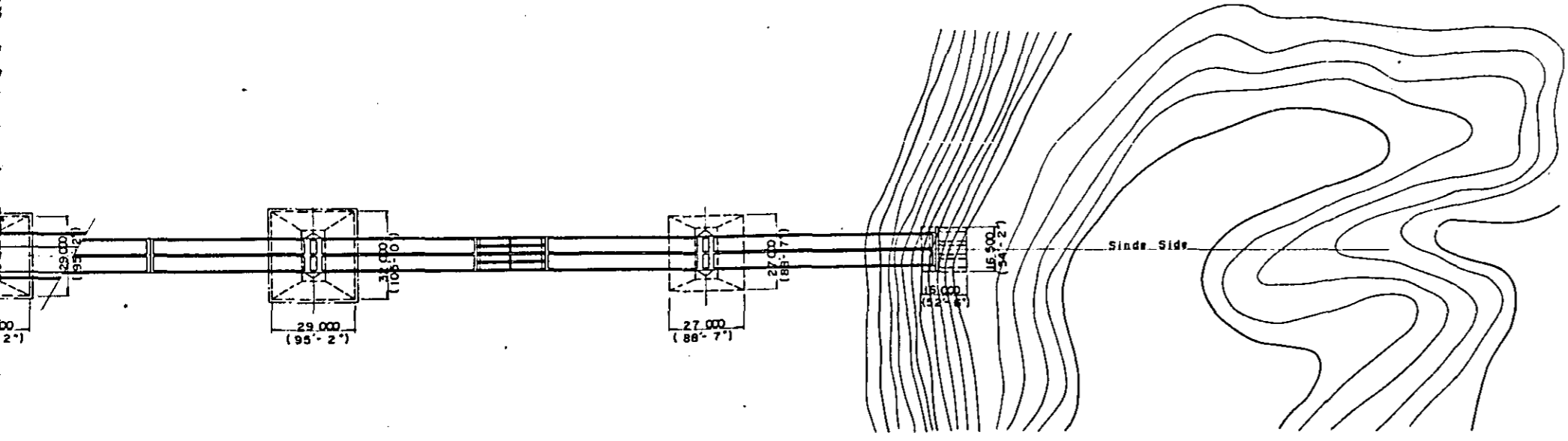
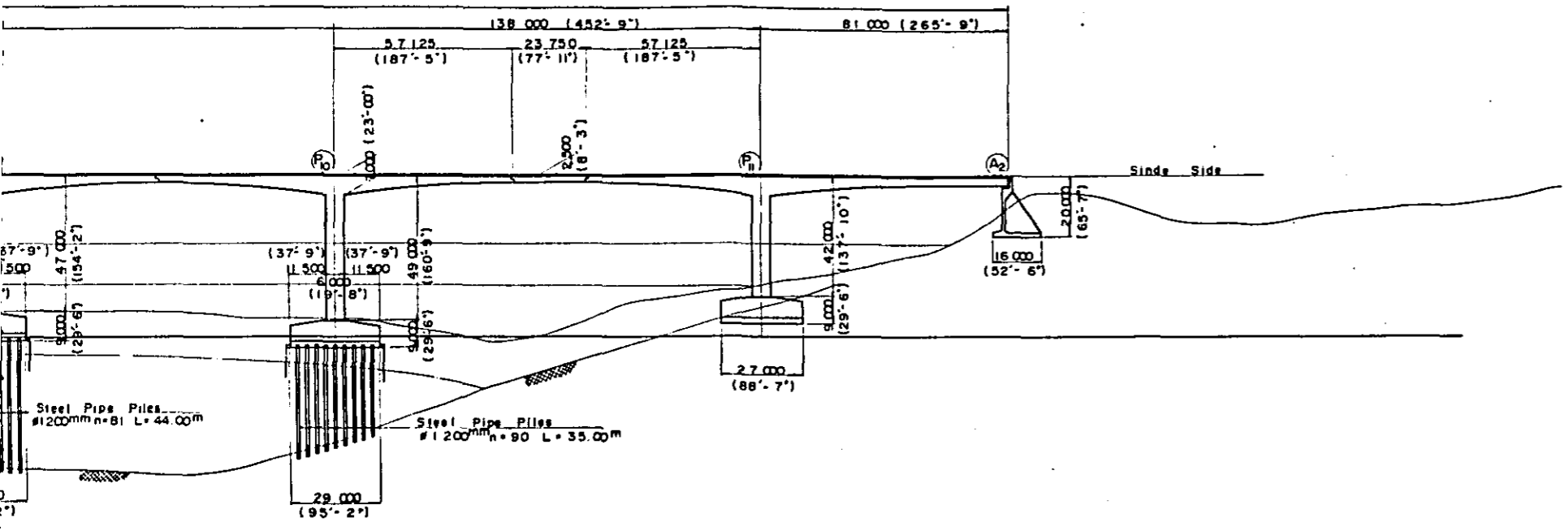

CROSS SECTION

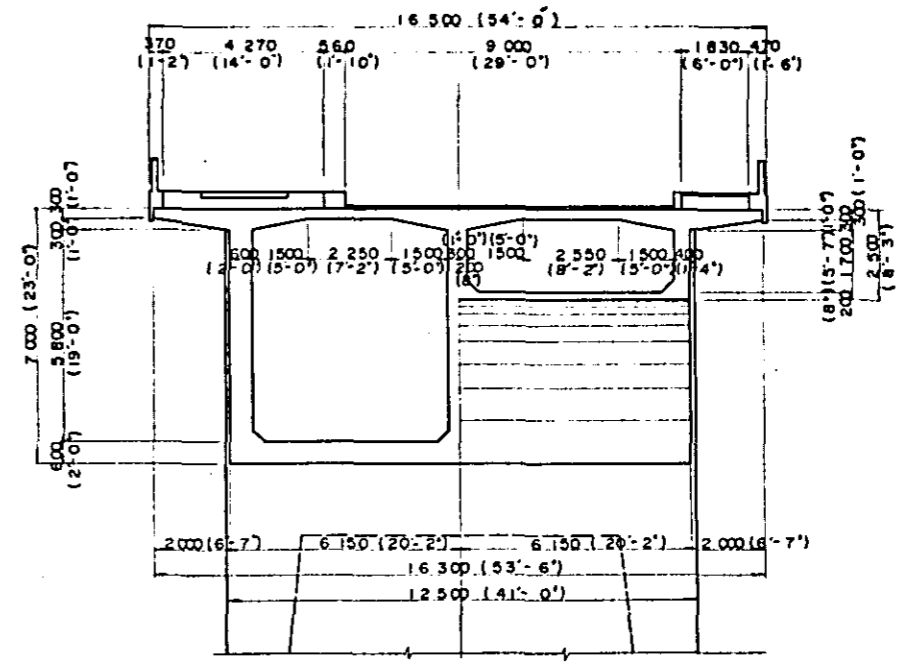

CROSS SECTION

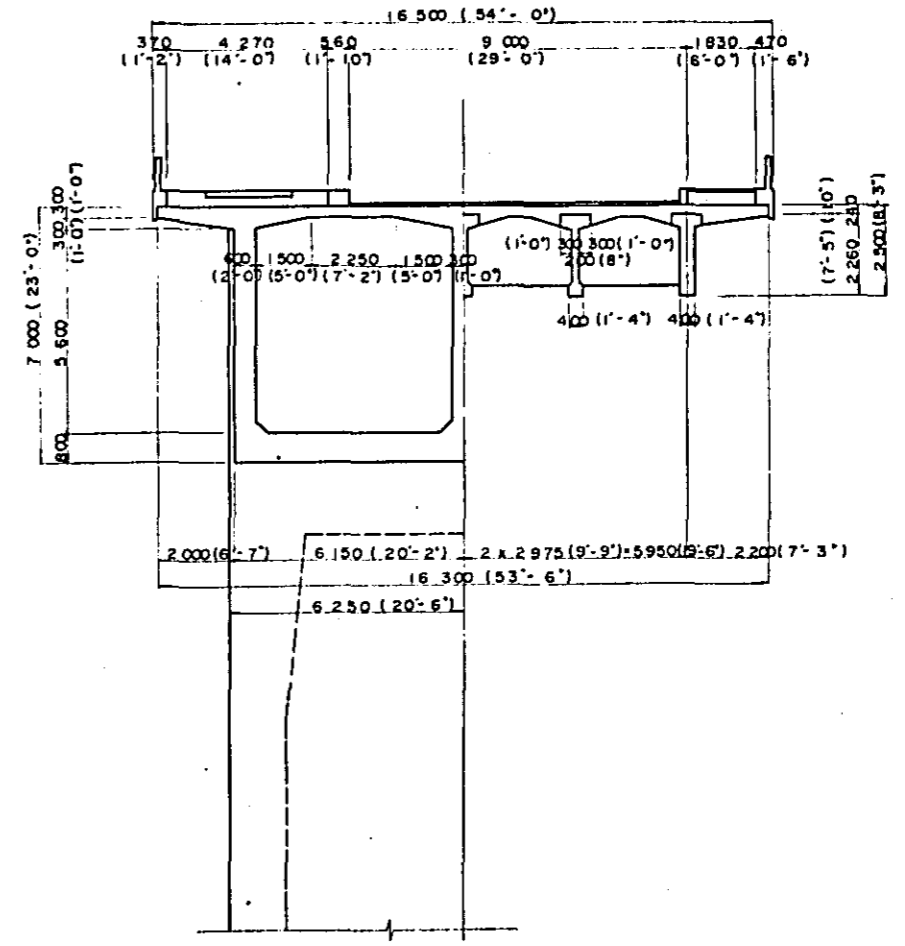

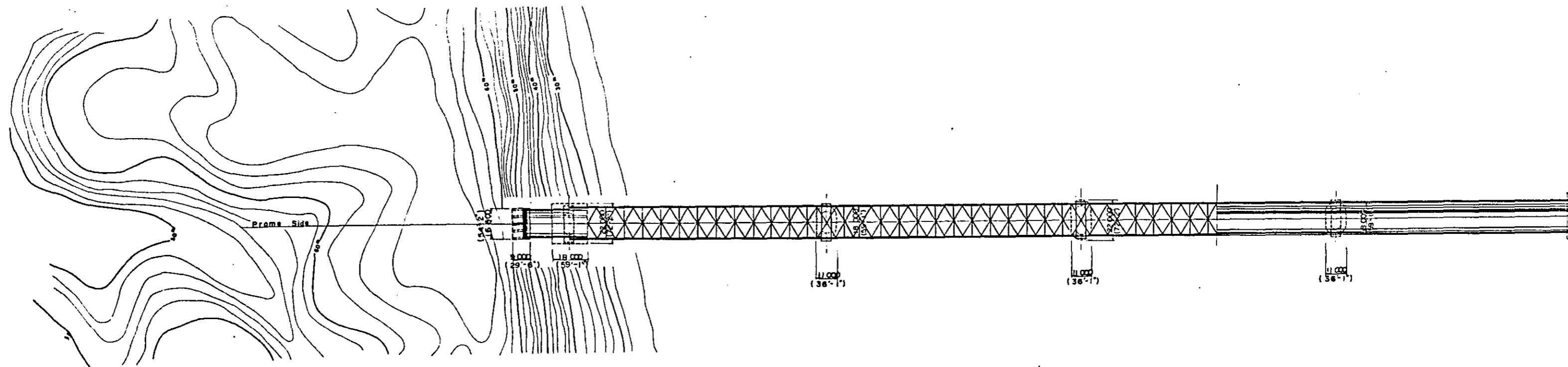
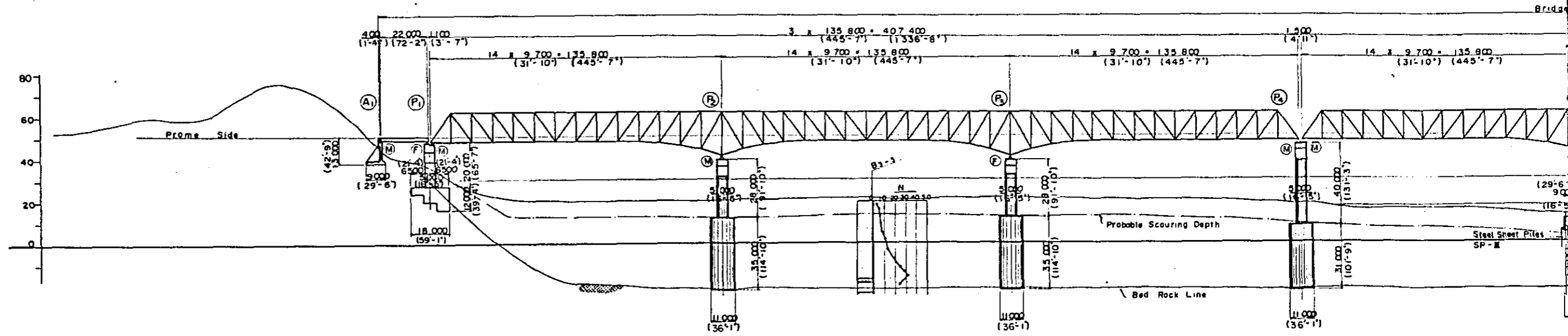



SIDE ELEVATION

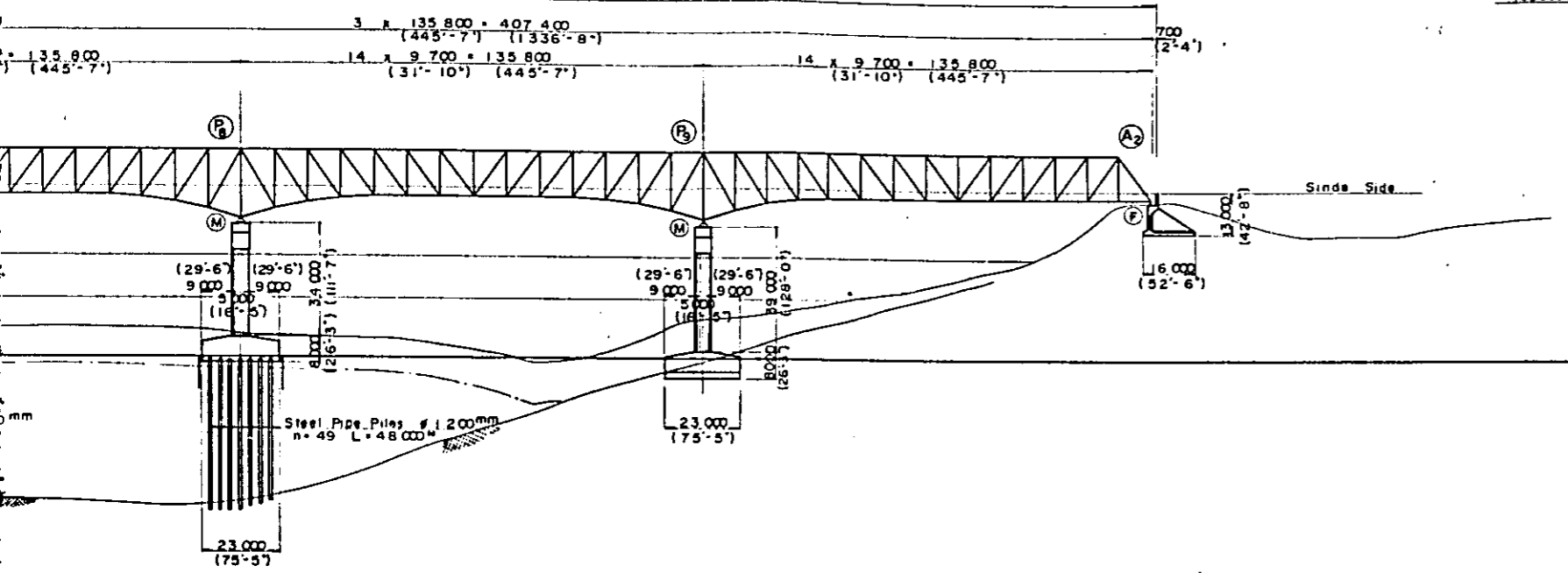

Proposed Height 51.7 m

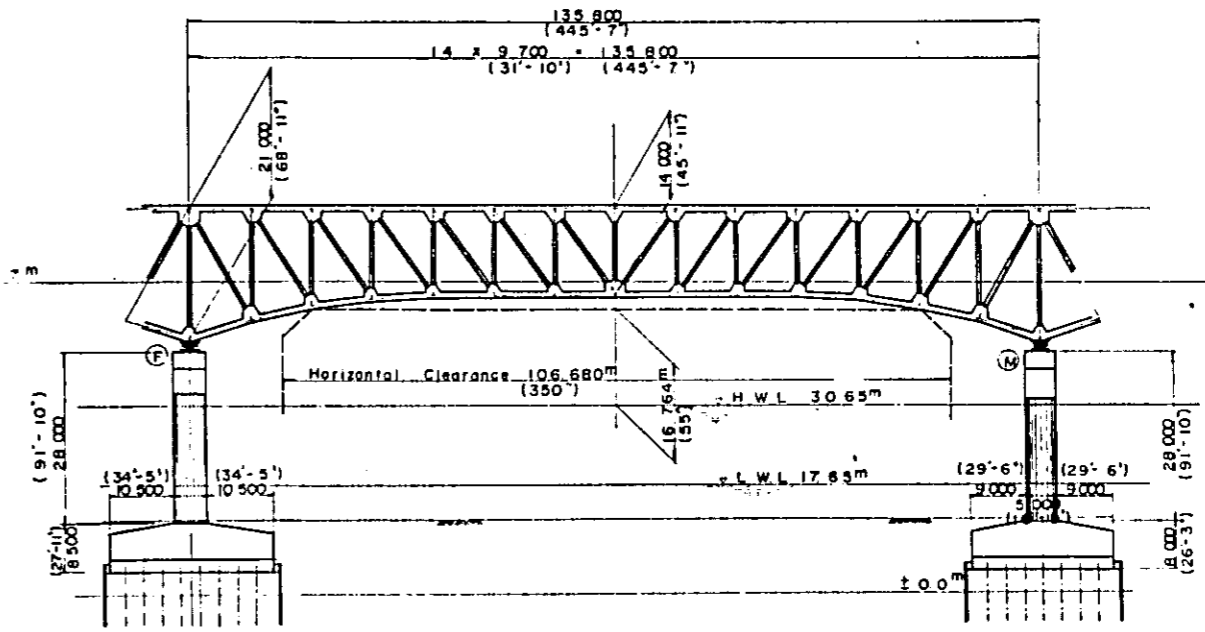

CROSS SECTION

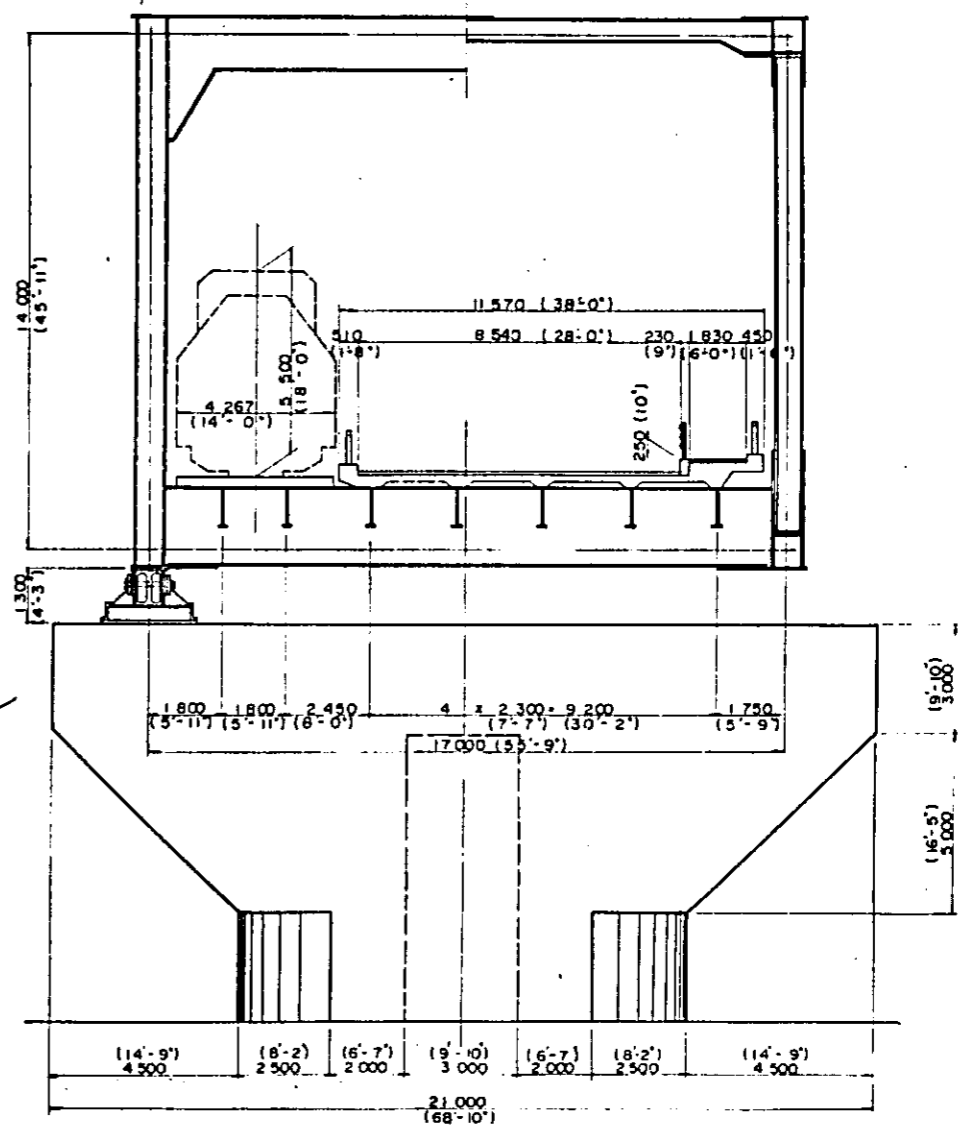
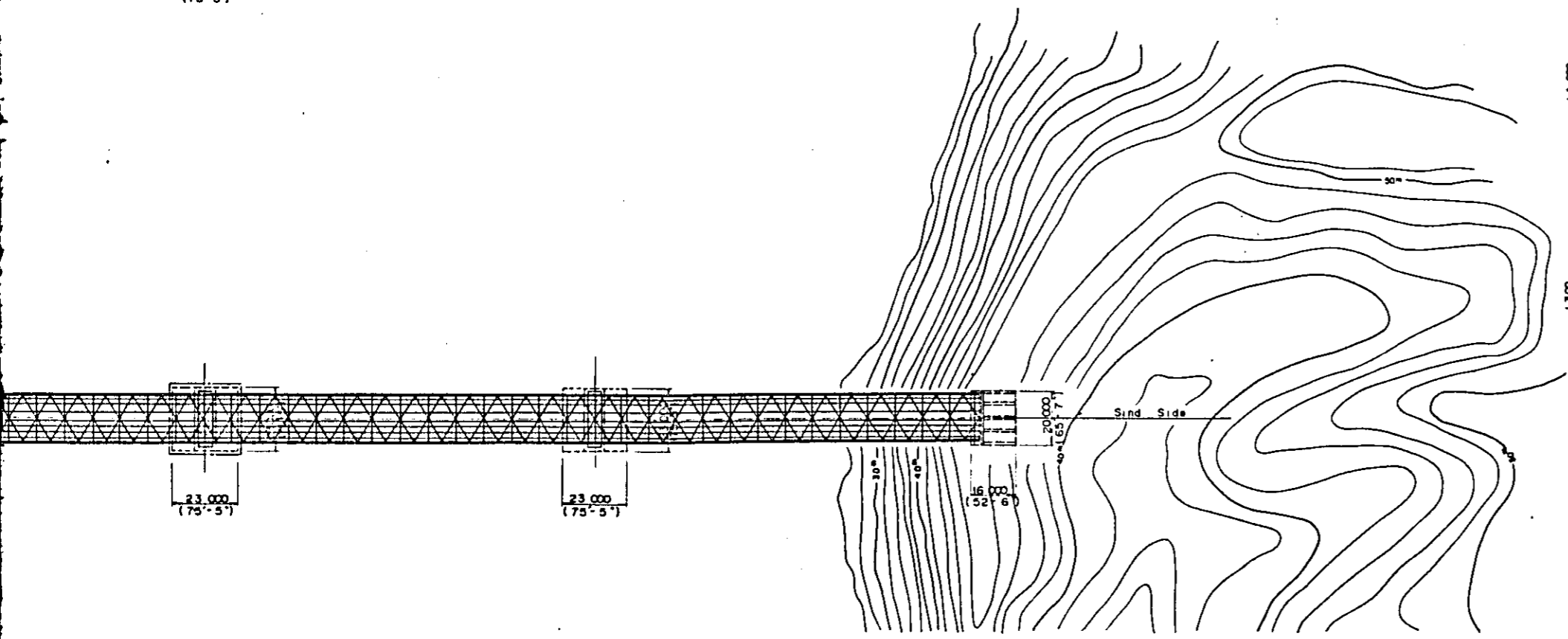

PRESTRESSED CONCRETE HIGHWAY BRIDGE AND F

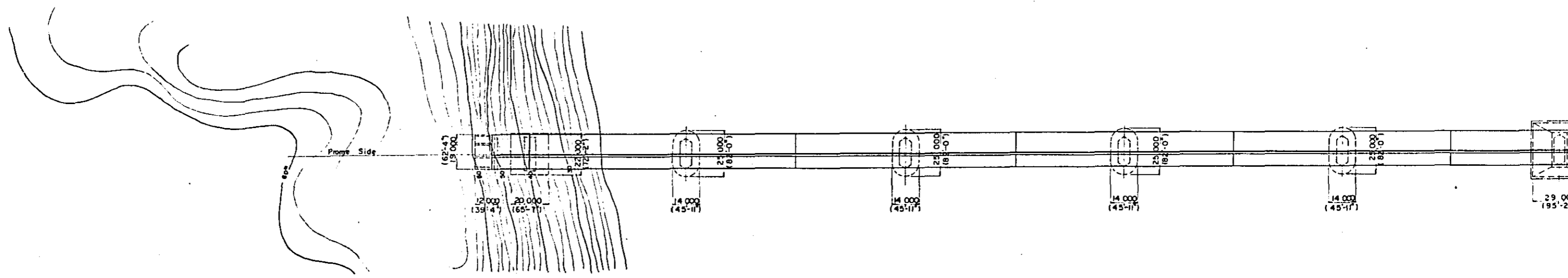
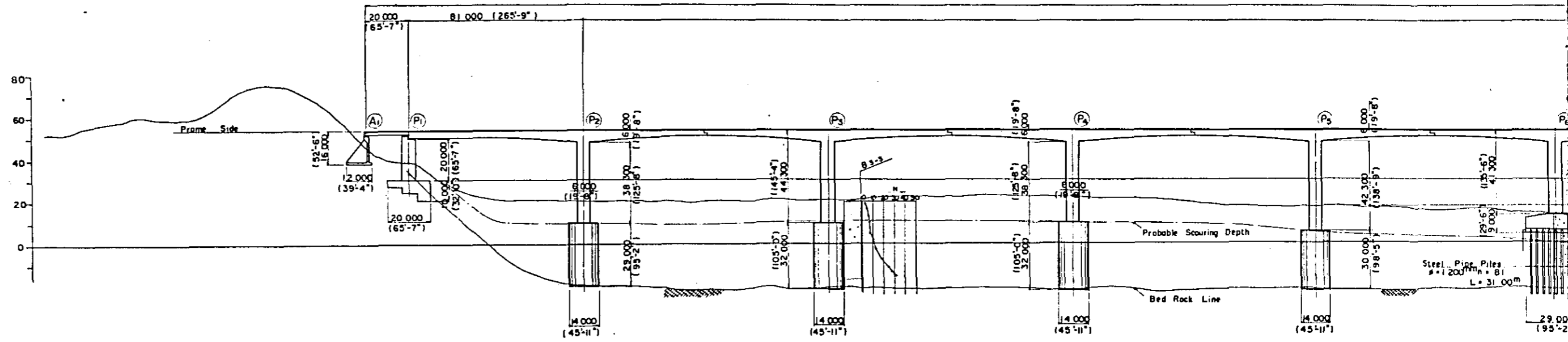





CROSS SECTION

RAILWAY BRIDGE      HIGHWAY BRIDGE

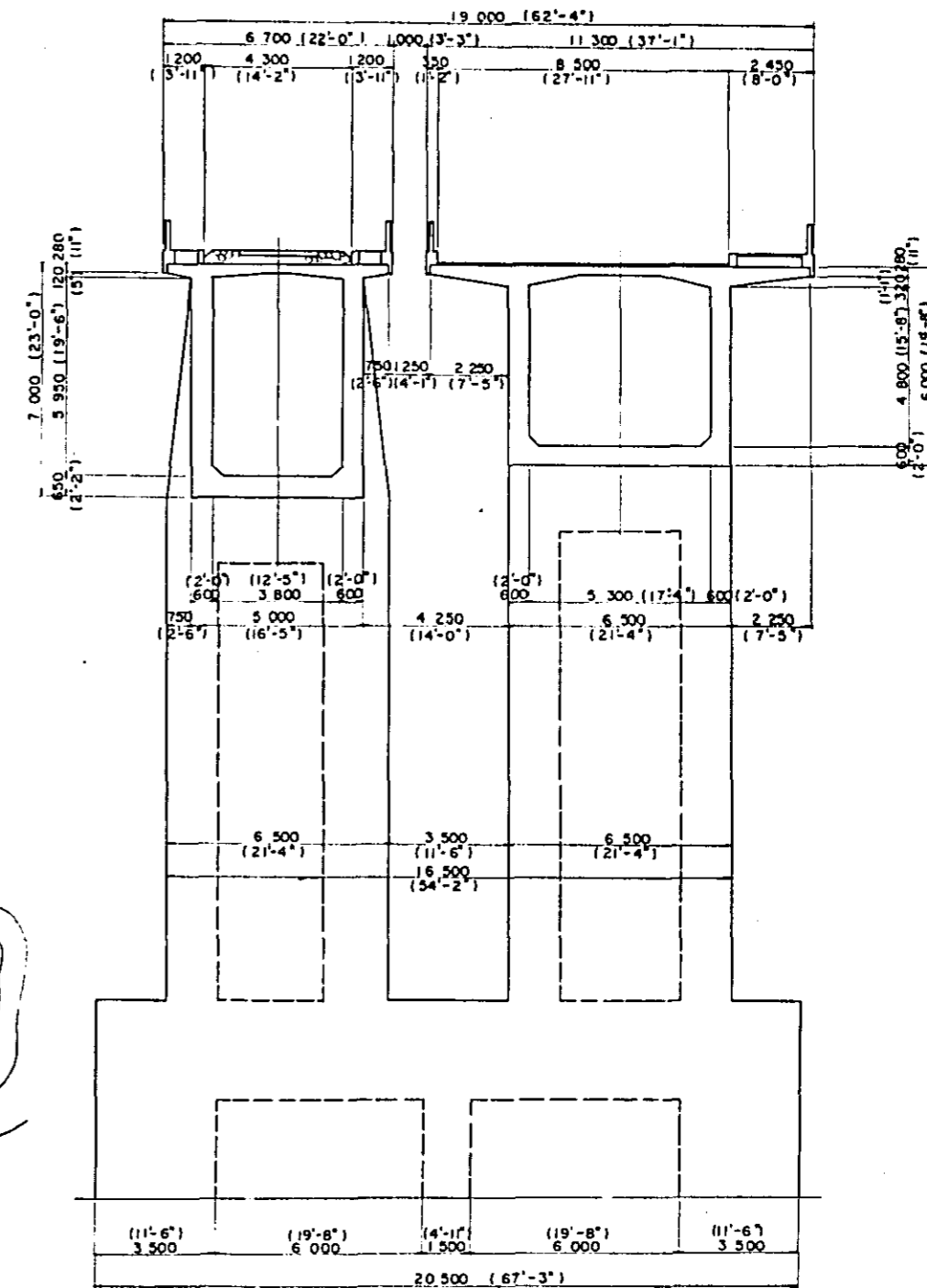
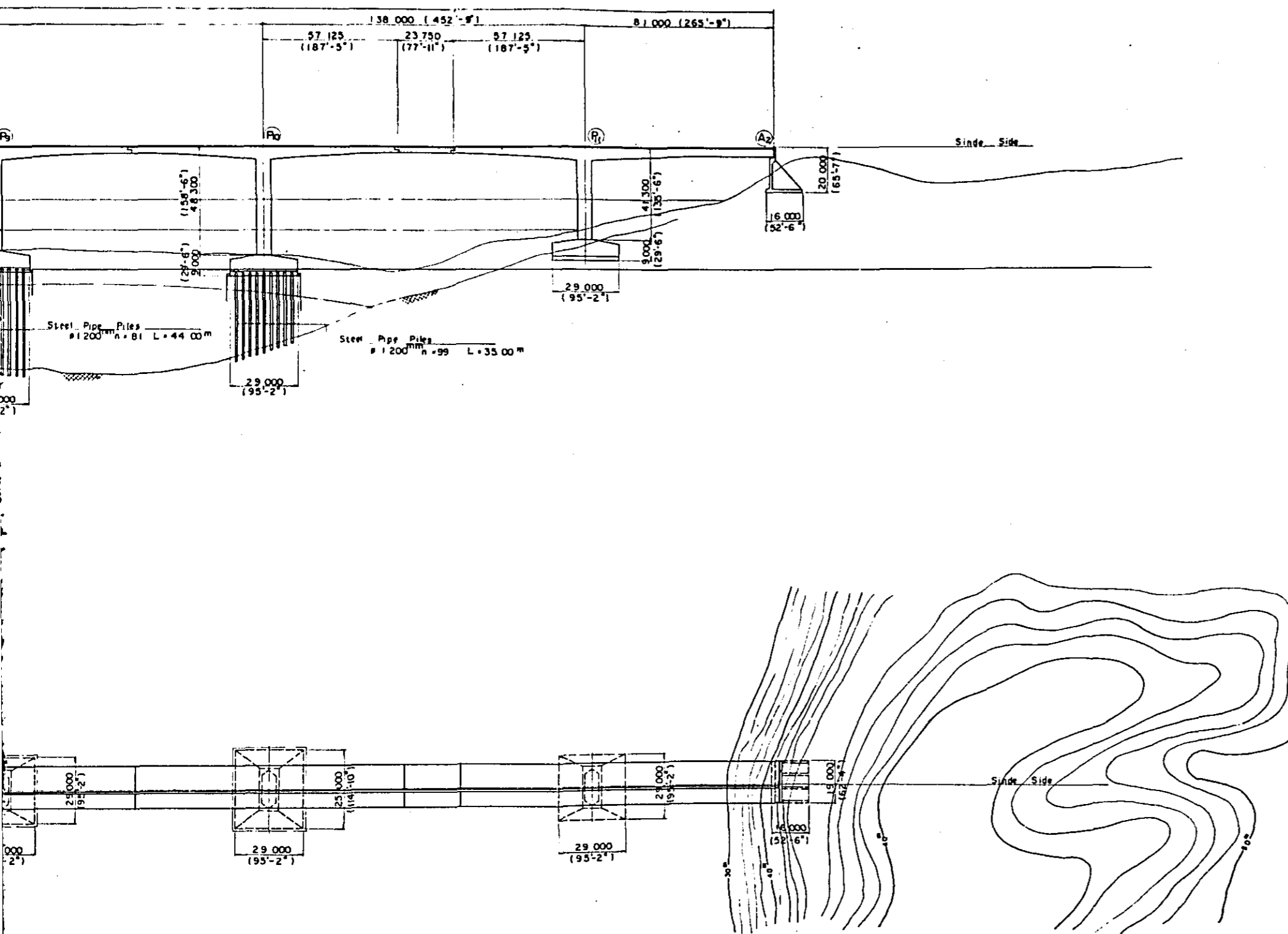

STEEL HIGHWAY BRIDGE AND RAILWAY BRIDGE SEPARATE

SIDE E

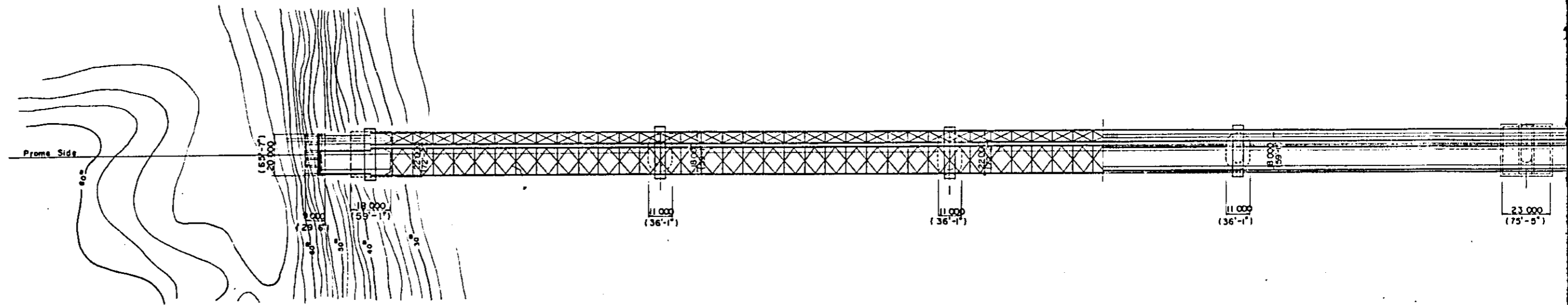
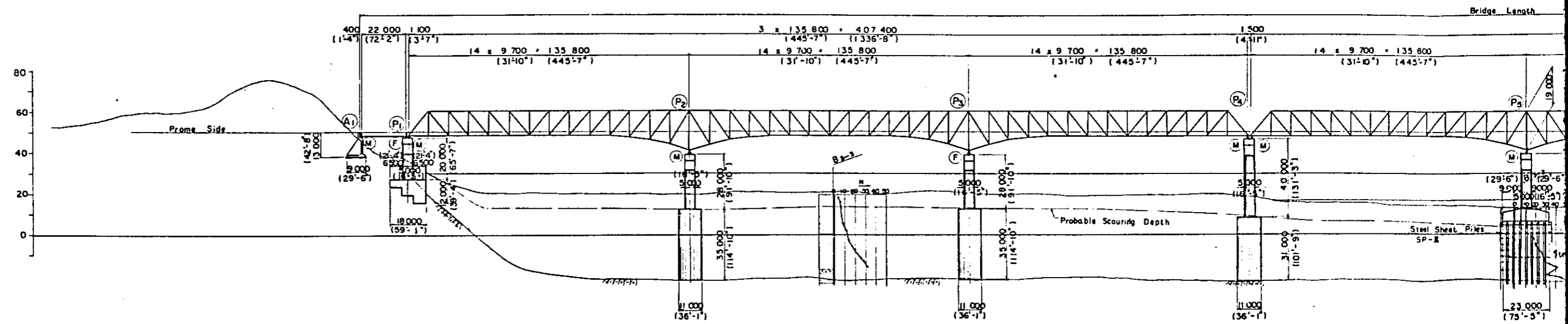



SIDE ELEVATION

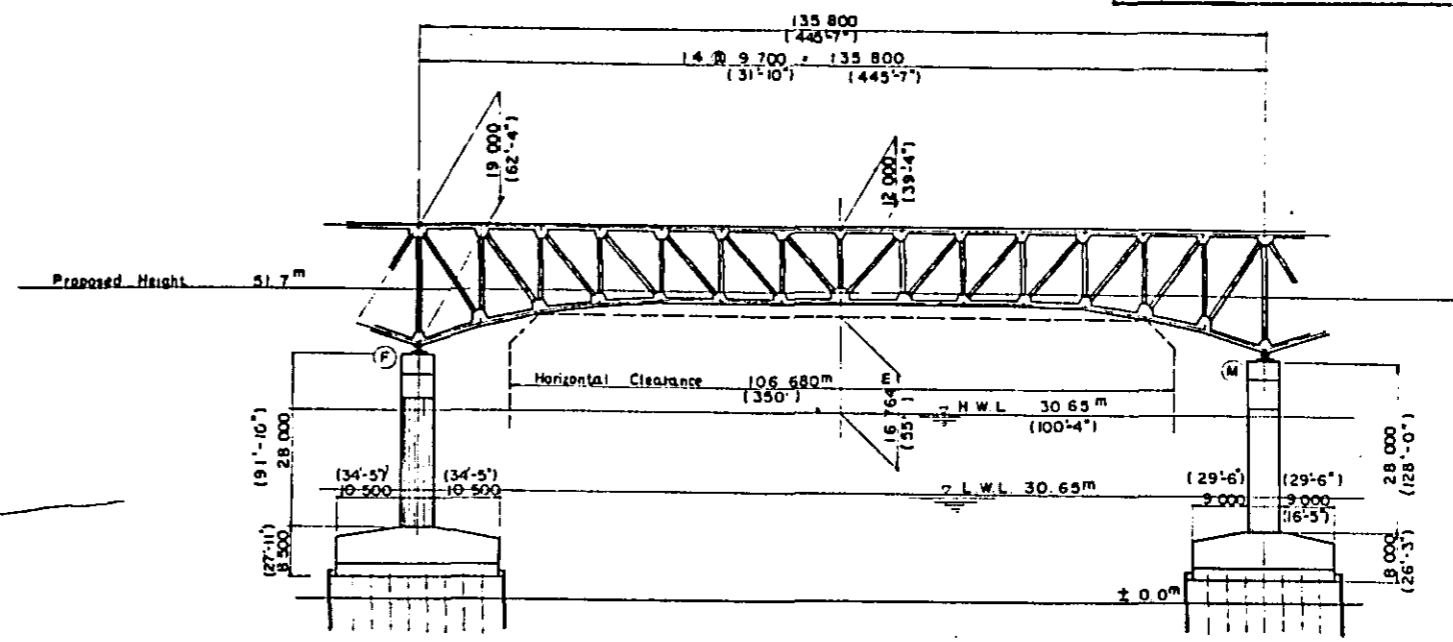

CROSS SECTION

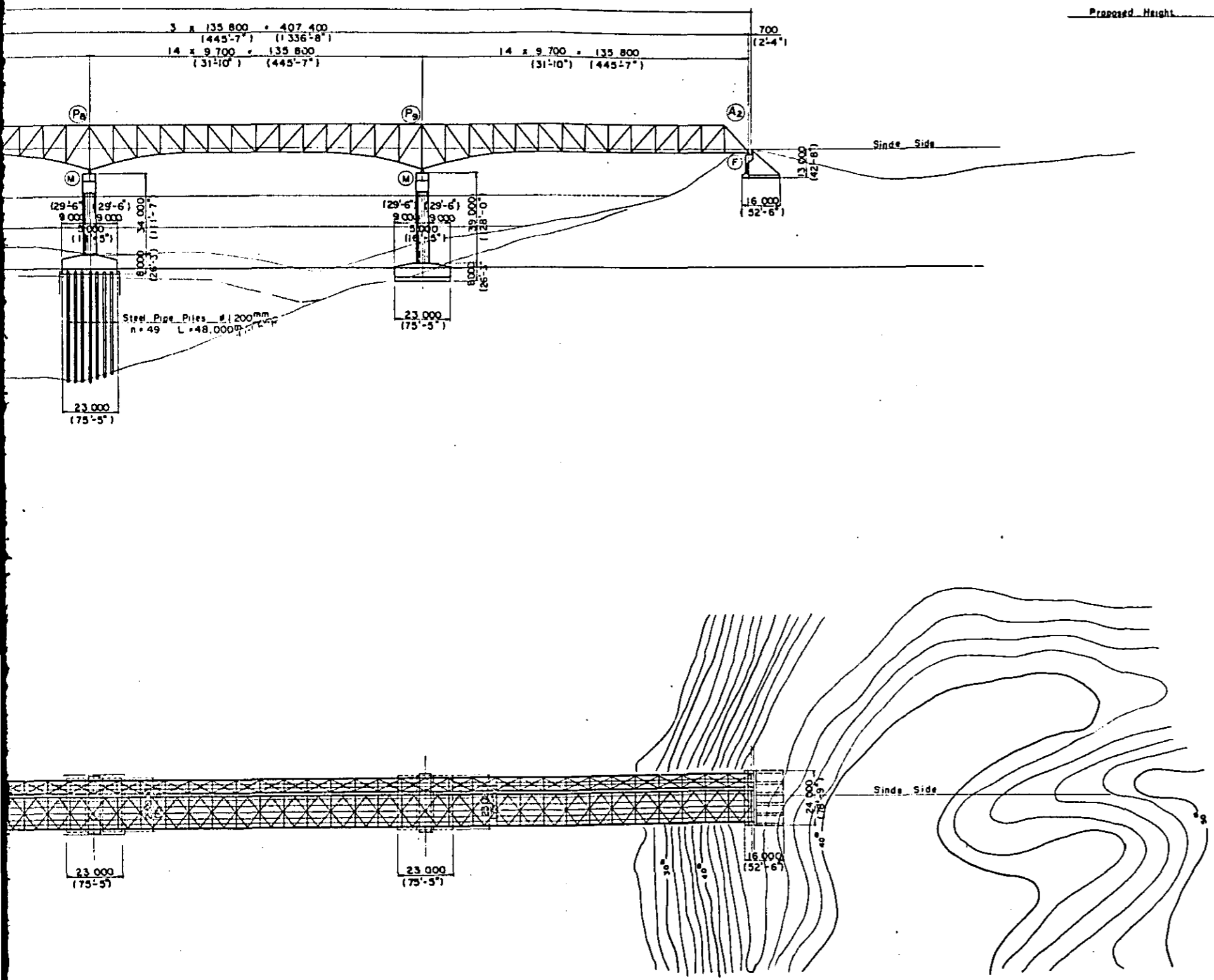
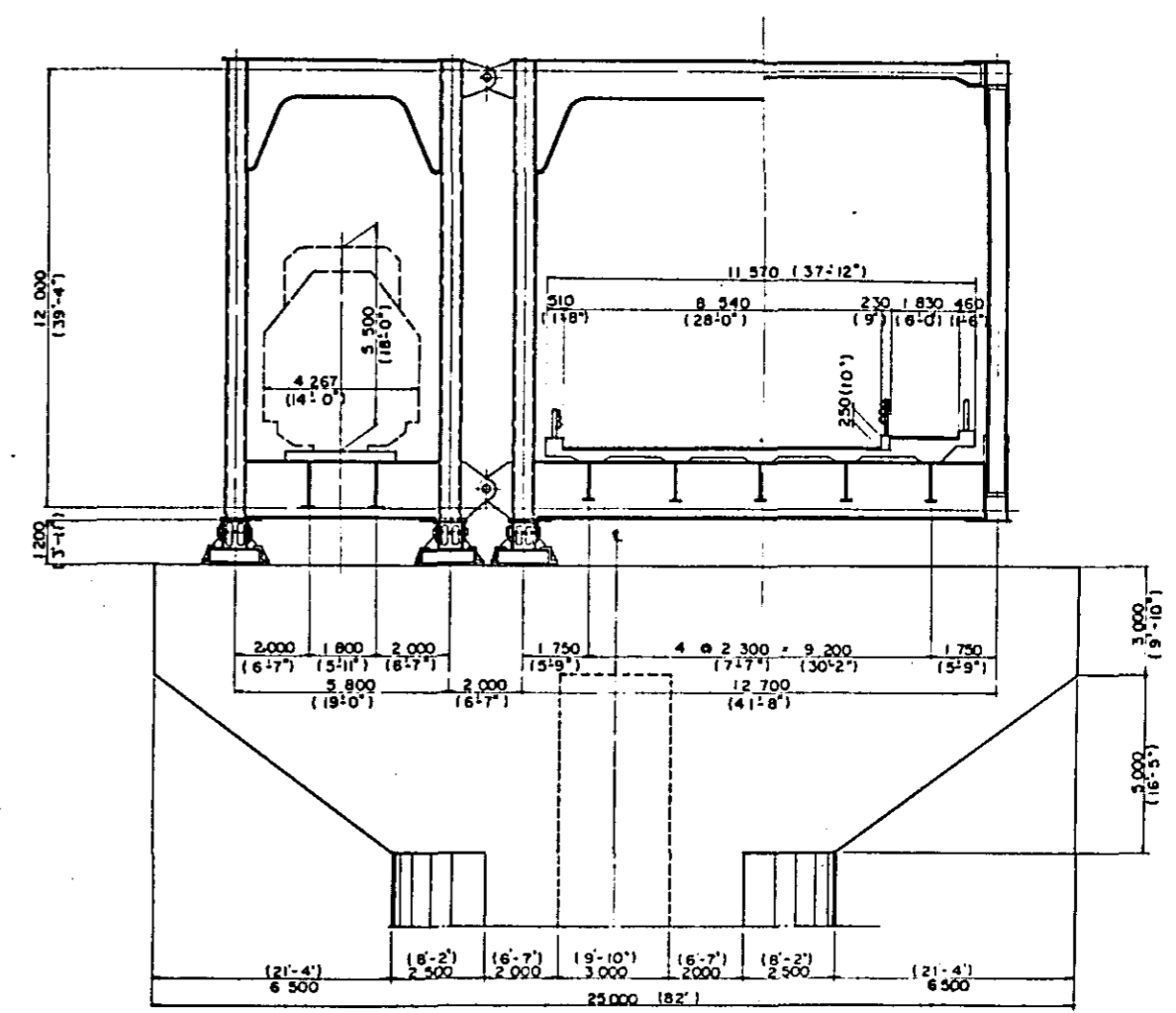

PRESTRESSED CONCRETE HIGHWAY - RAILWAY BR

SIDE ELEVATION

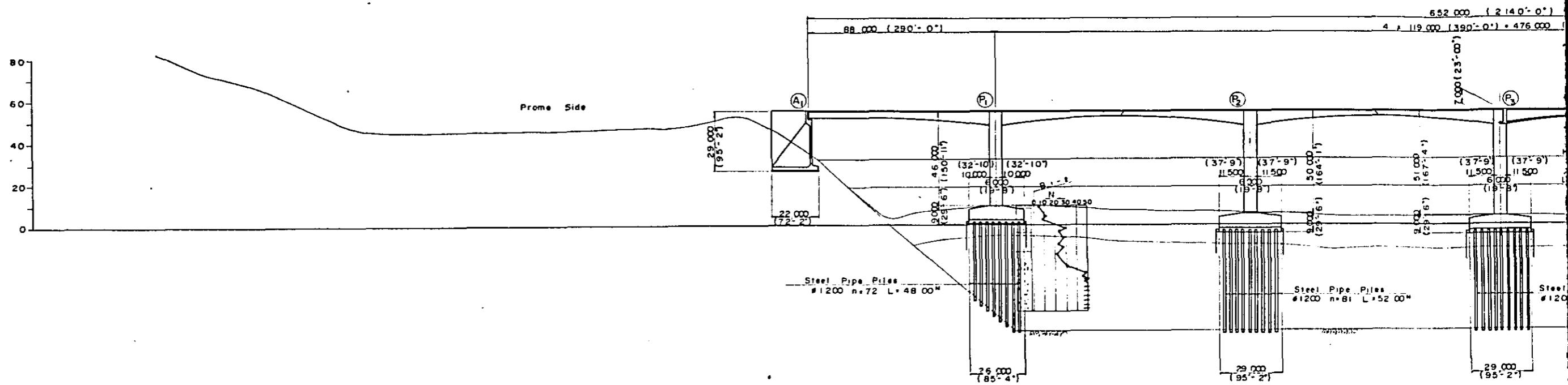

PLAN

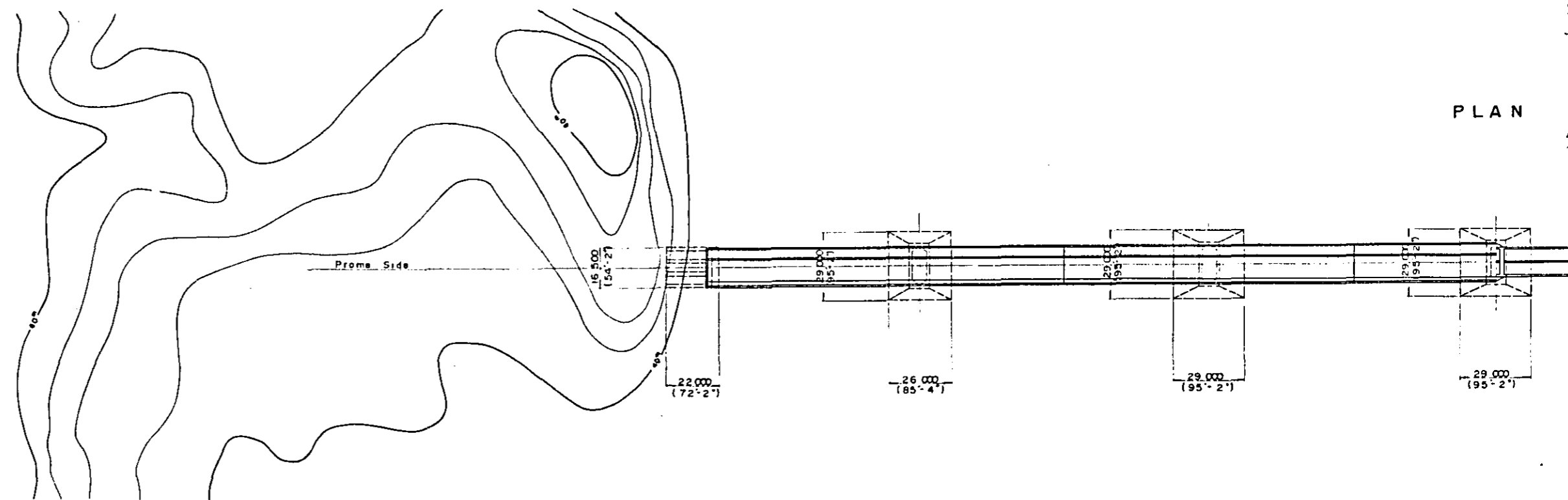



RESTRESSED CONCRETE HIGHWAY - RAILWAY BRIDGE AT SITE NO. 1

SIDE ELEVATION

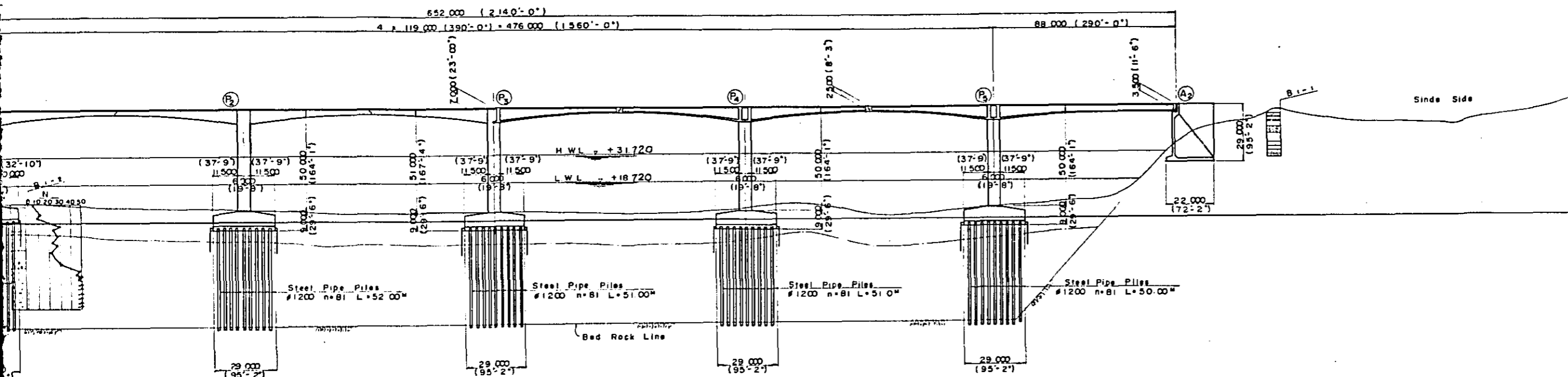

PLAN

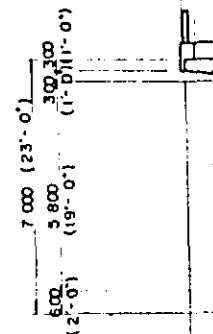
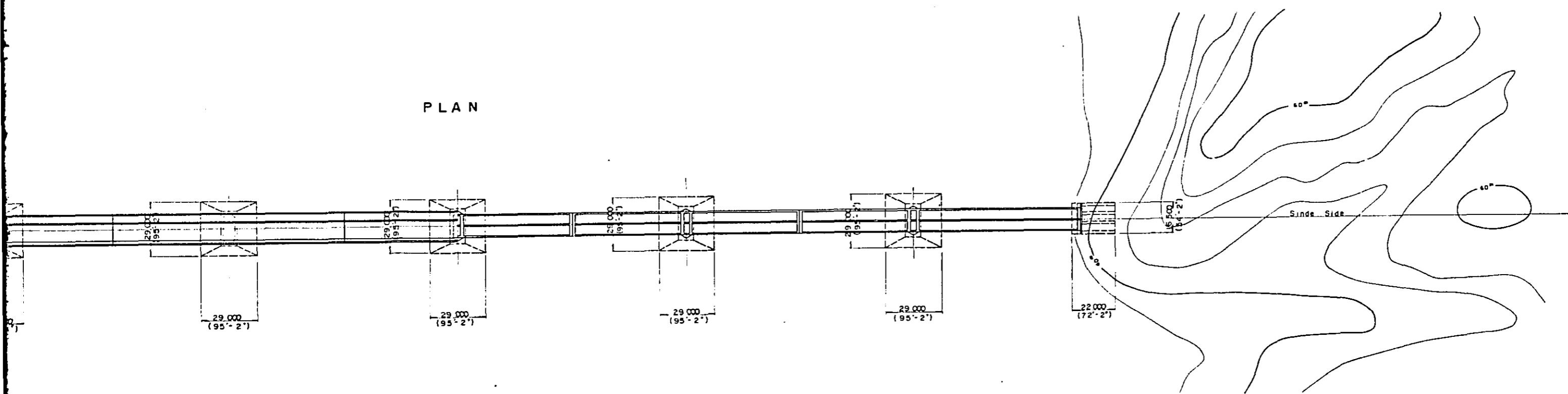

E NO.1

CROSS SECTION

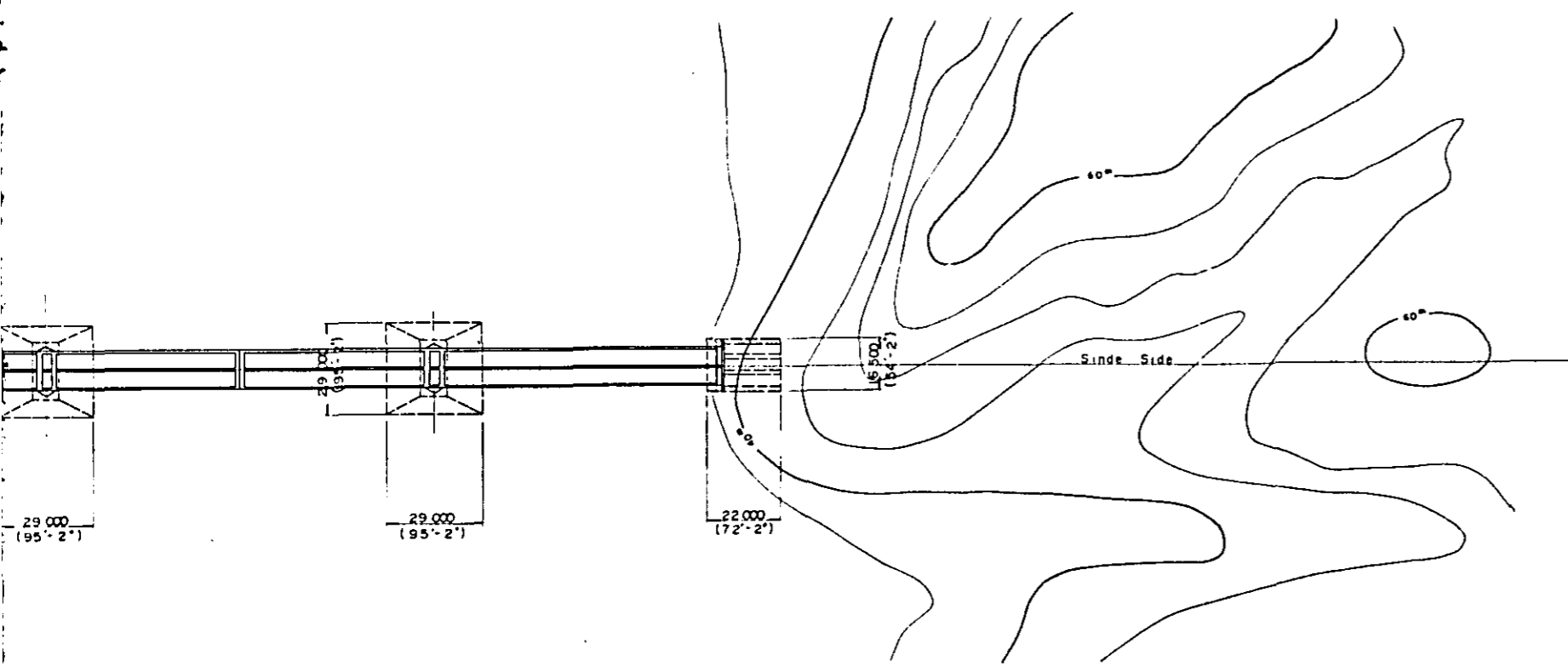
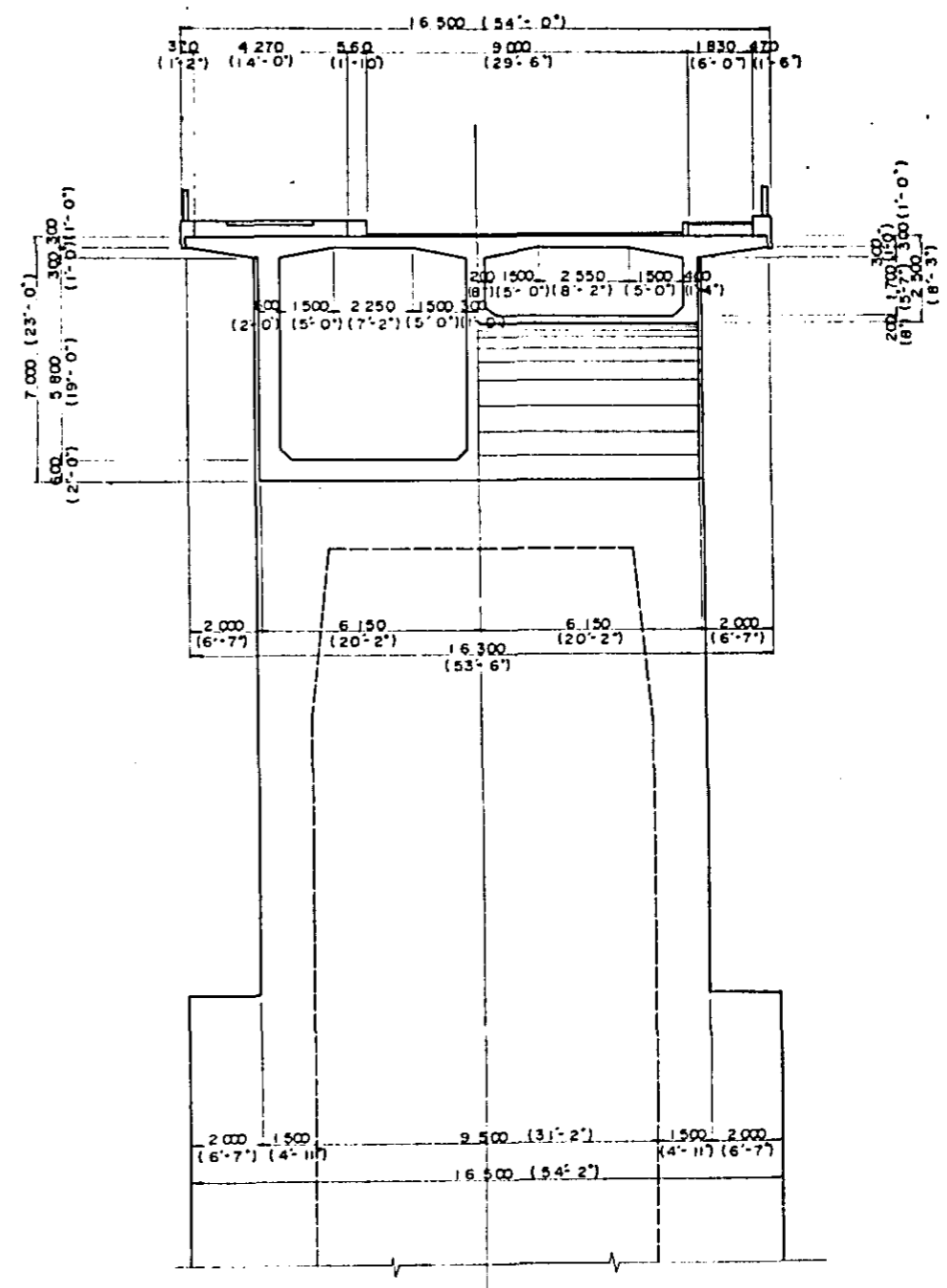
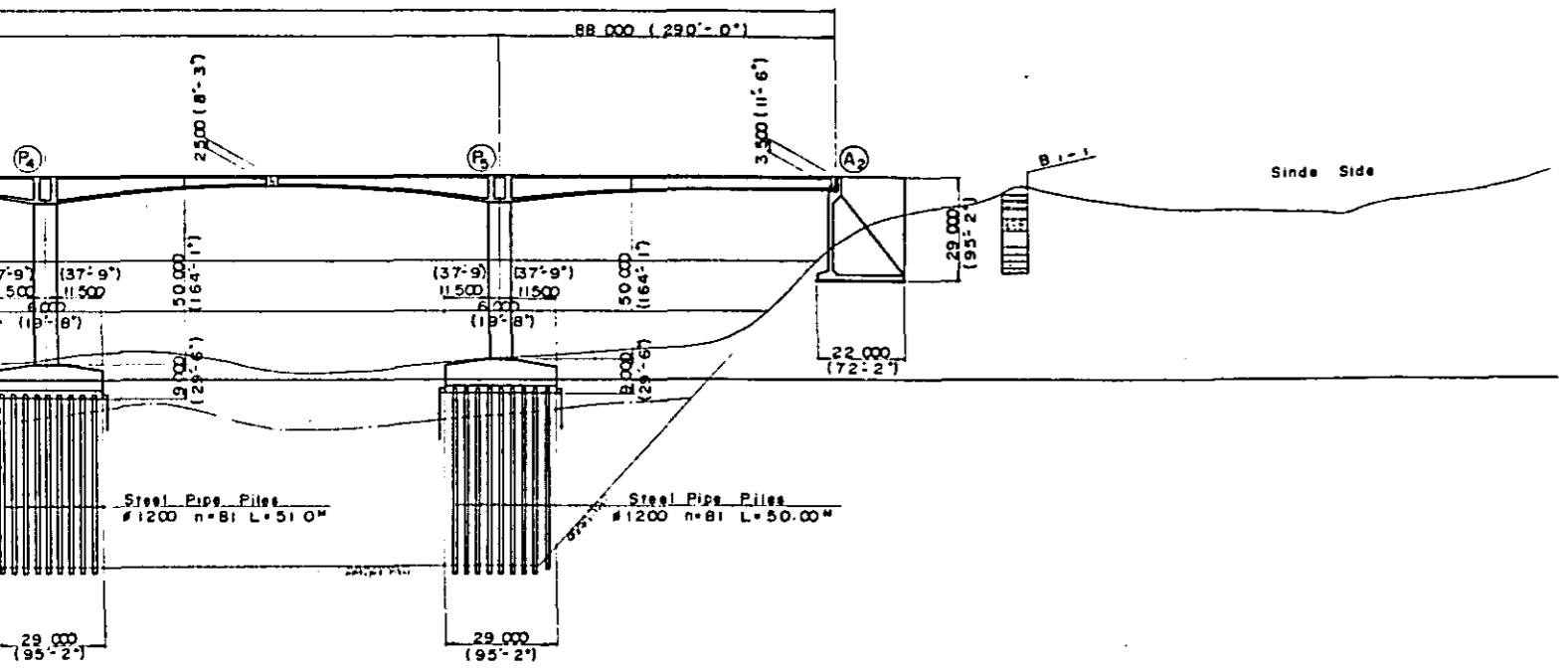

# STEEL HIGHWAY - RAILWAY BRIDGE

## SIDE ELEVATION

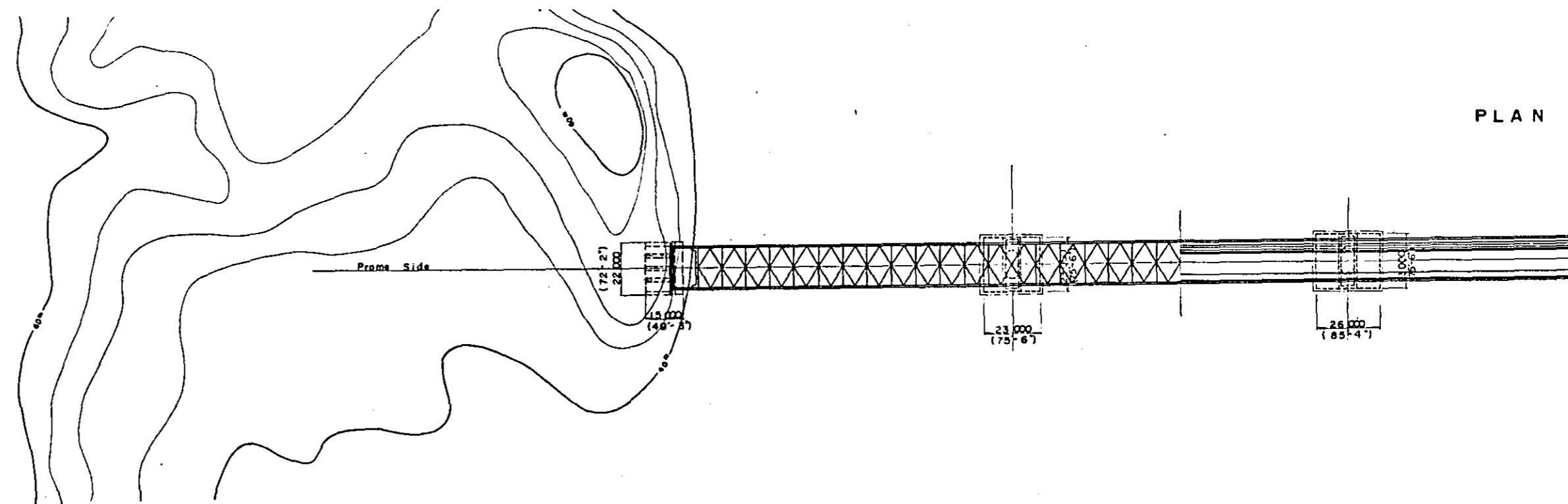
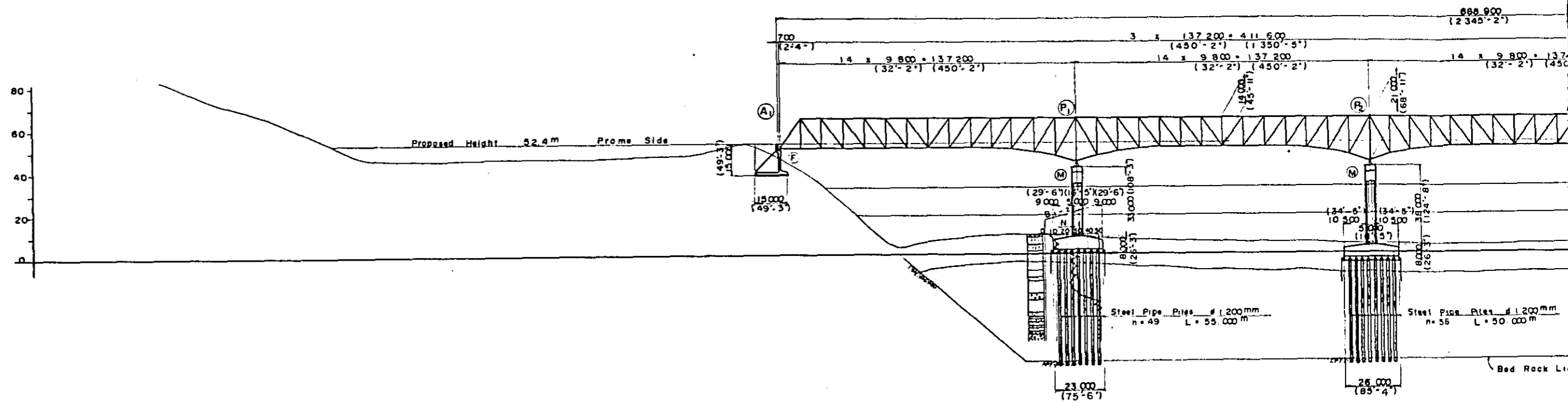

## PLAN

# STEEL HIGHWAY - RAILWAY BRIDGE AT SITE NO. 1

## SIDE ELEVATION

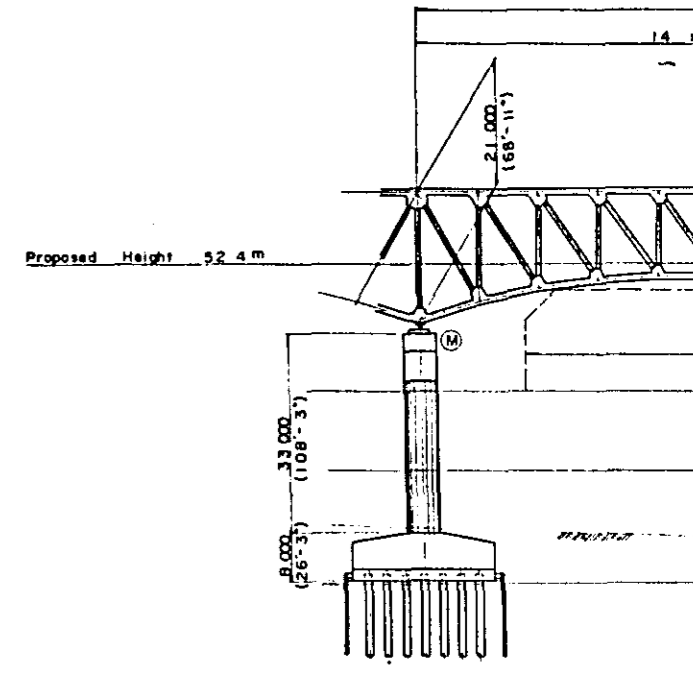
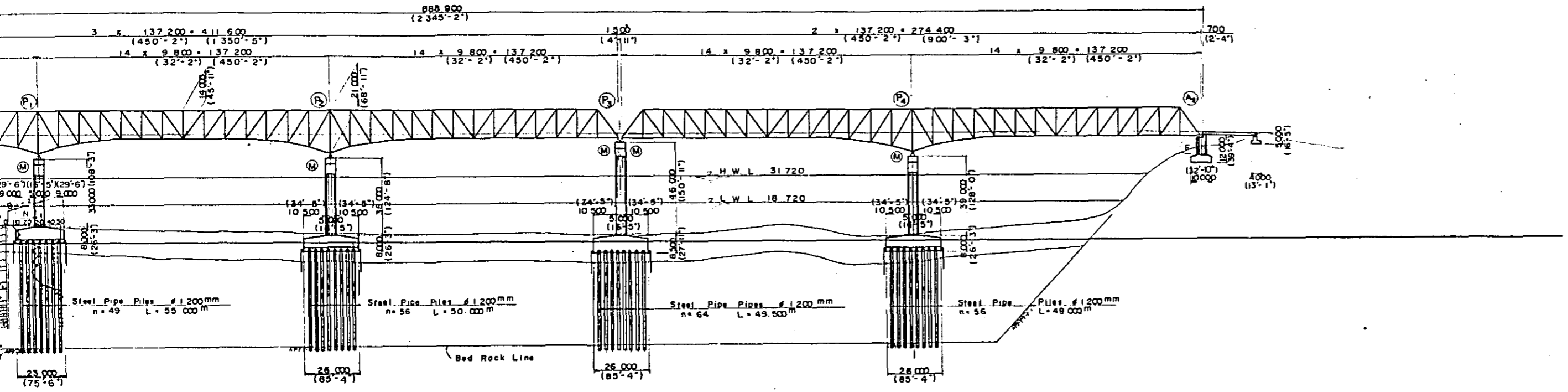

## PLAN

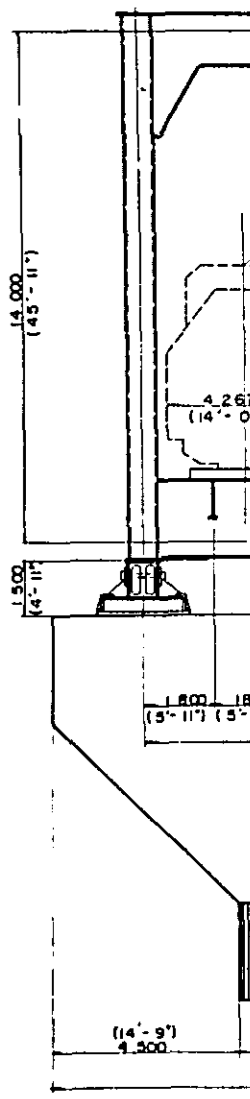
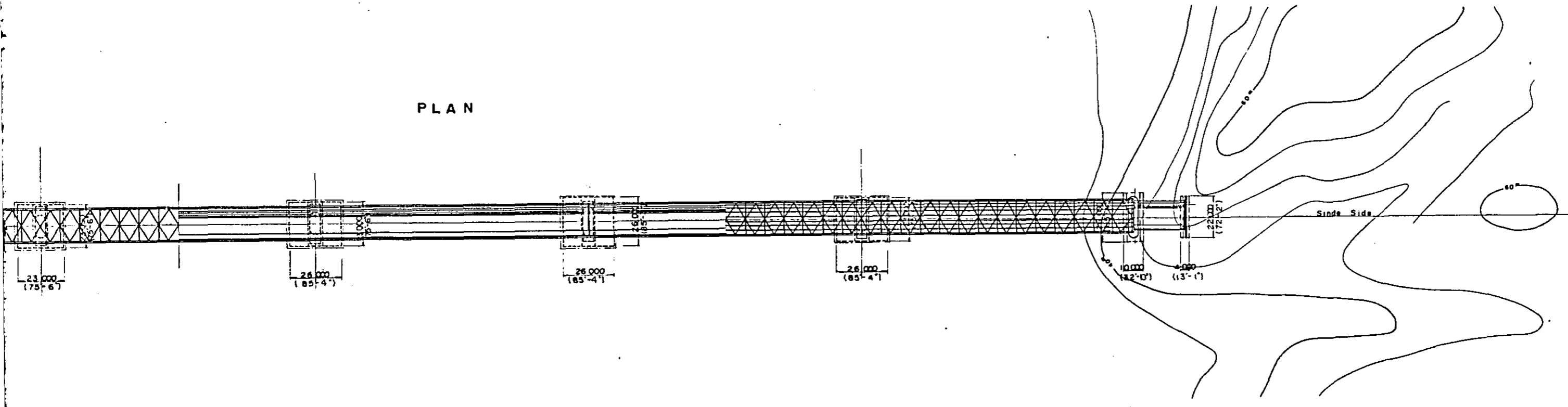

SIDE ELEVATION

NO. 1

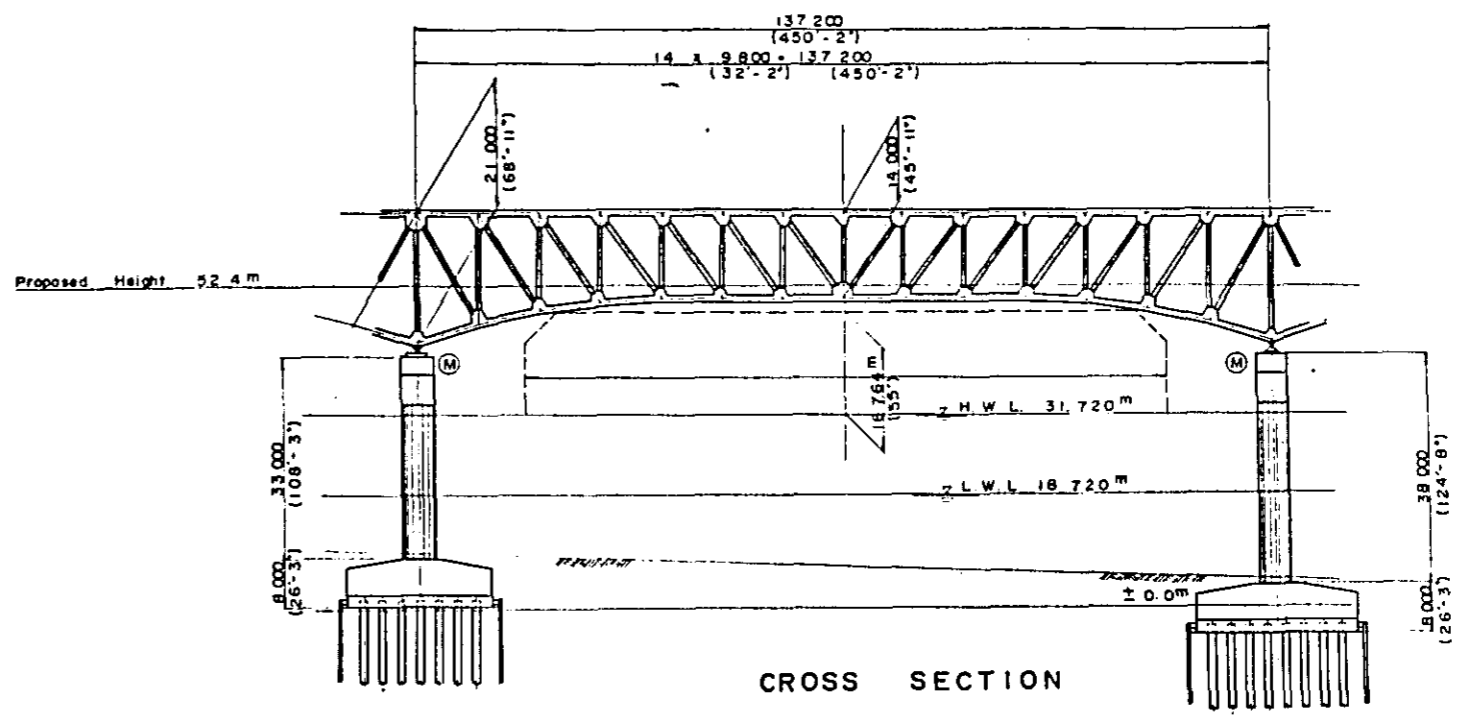
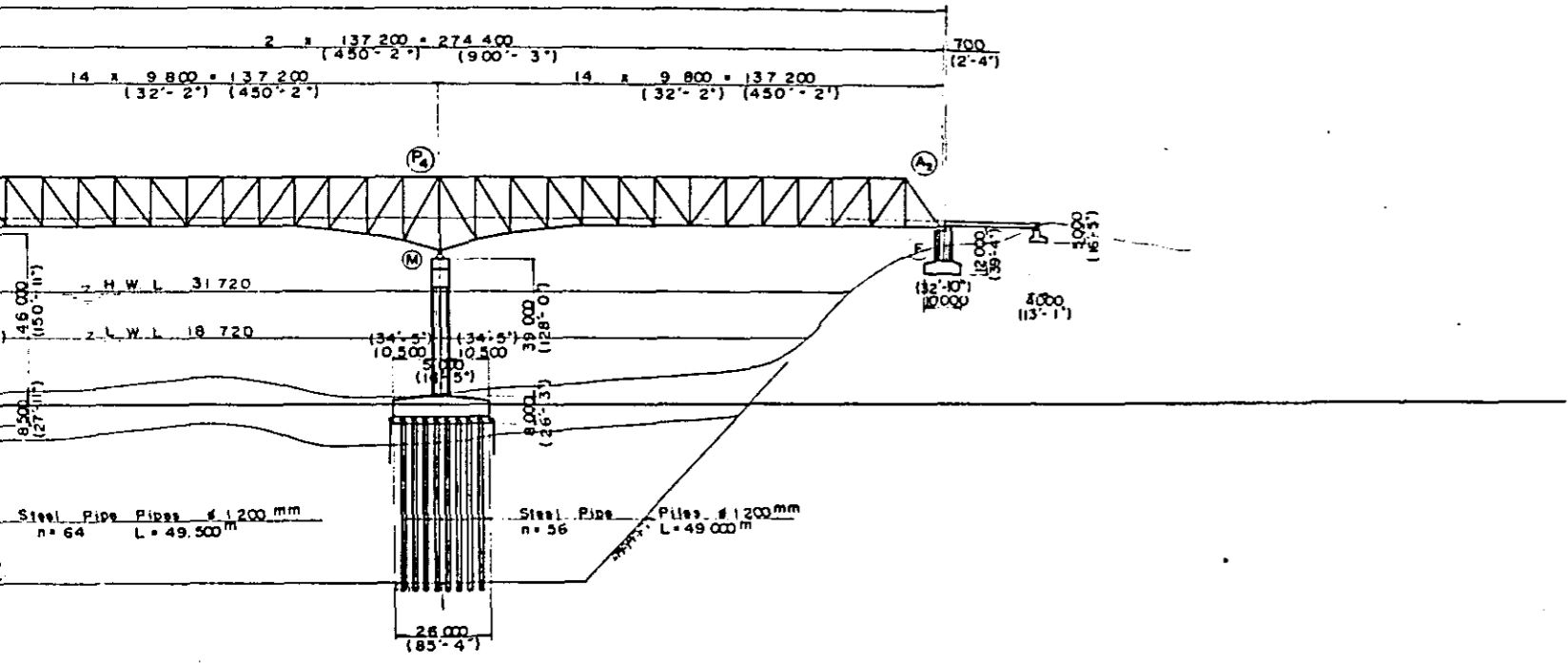

CROSS SECTION

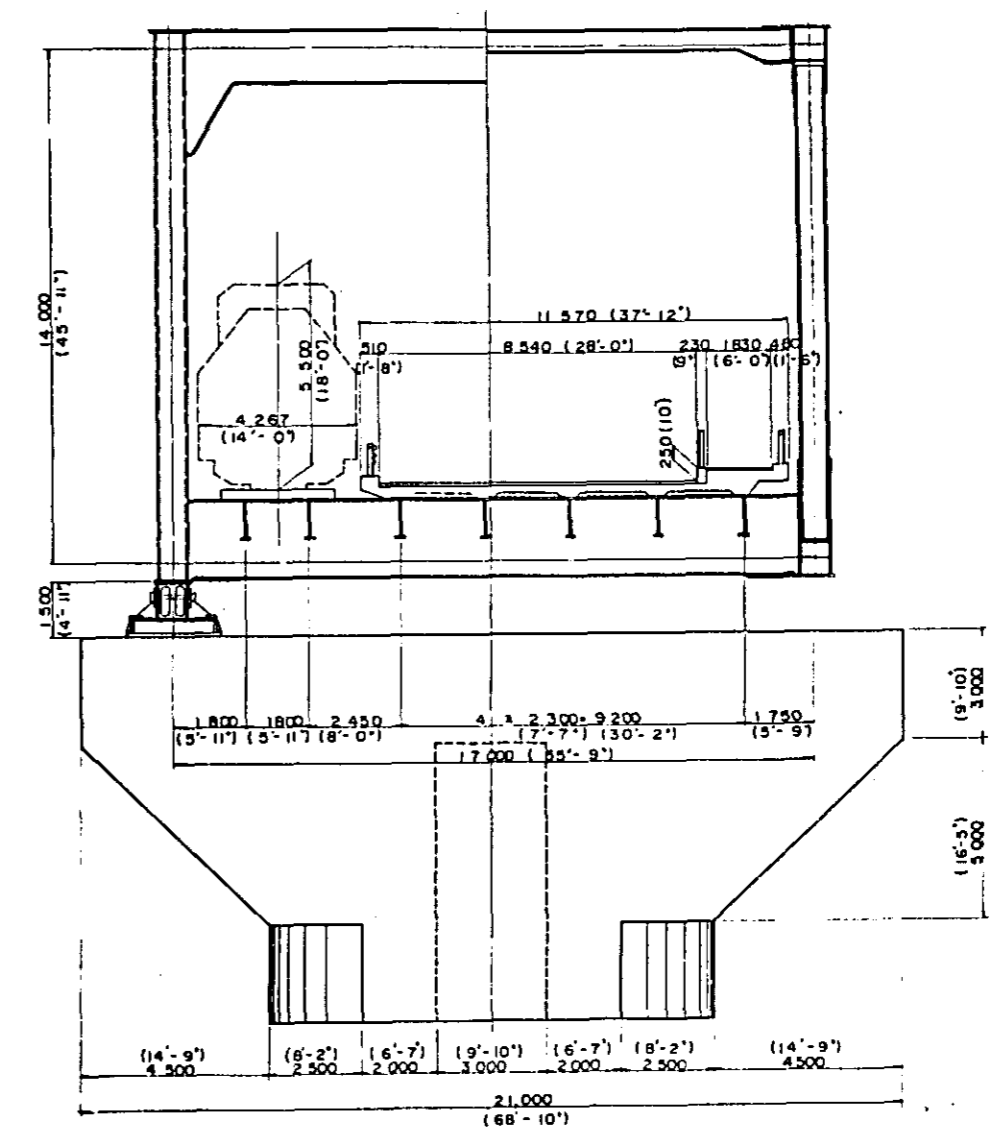
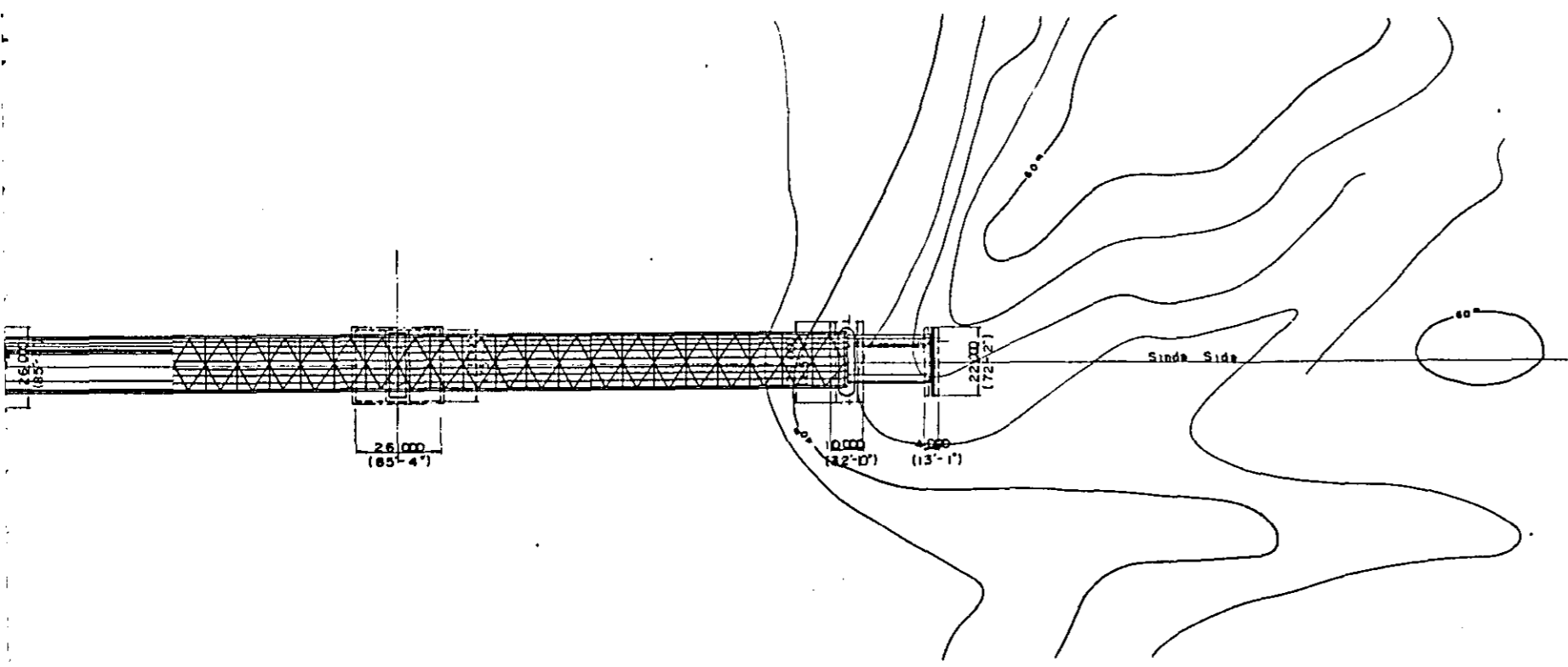





# PRESTRESSED CONCRETE HIGHWAY-RAILWAY BRIDGE AT SITE NO.2

## SIDE ELEVATION

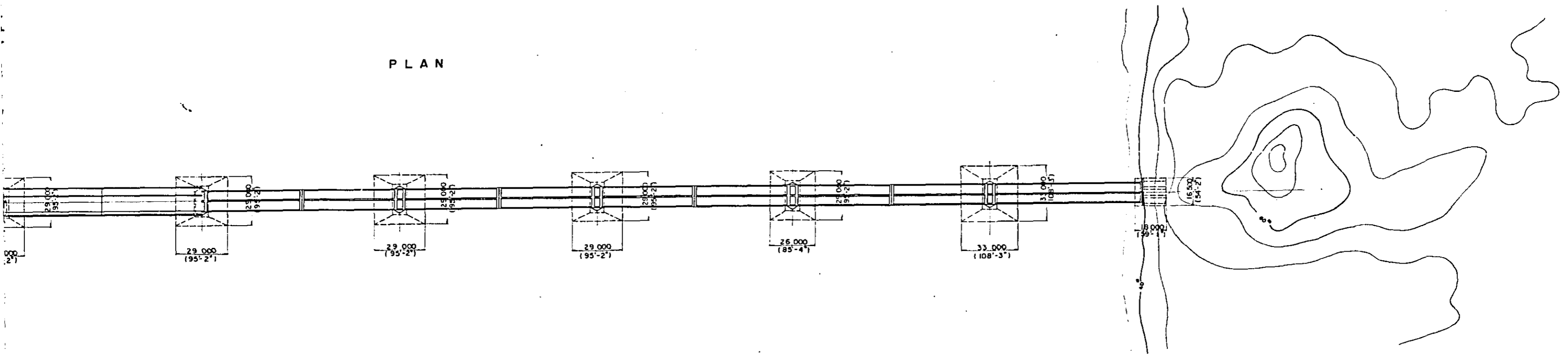
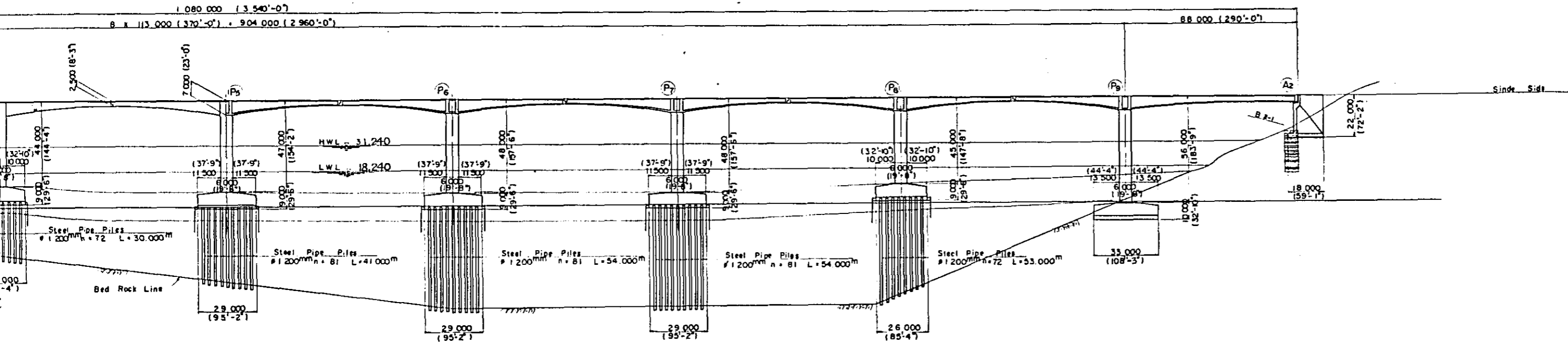

CROSS SECTION

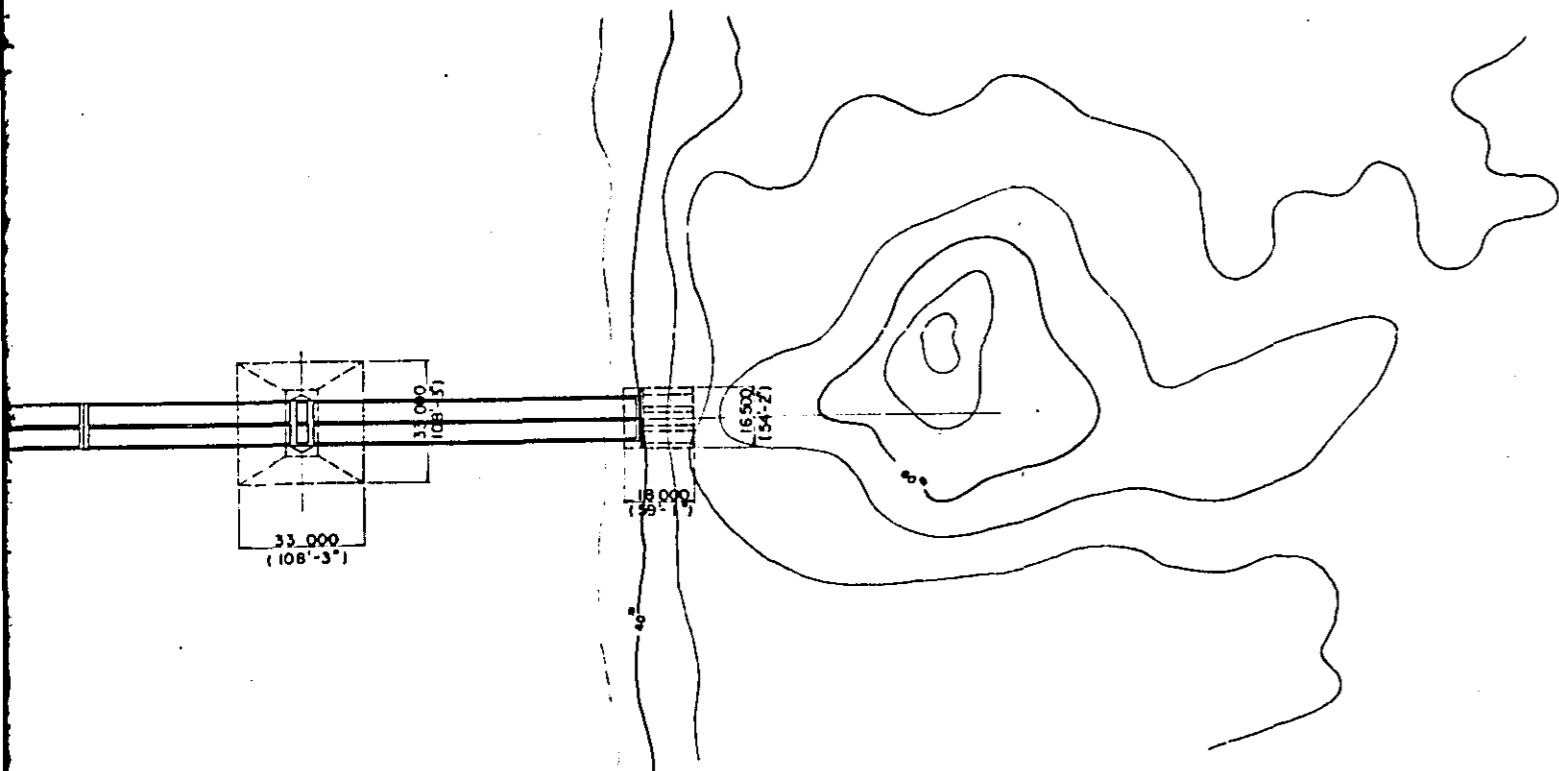
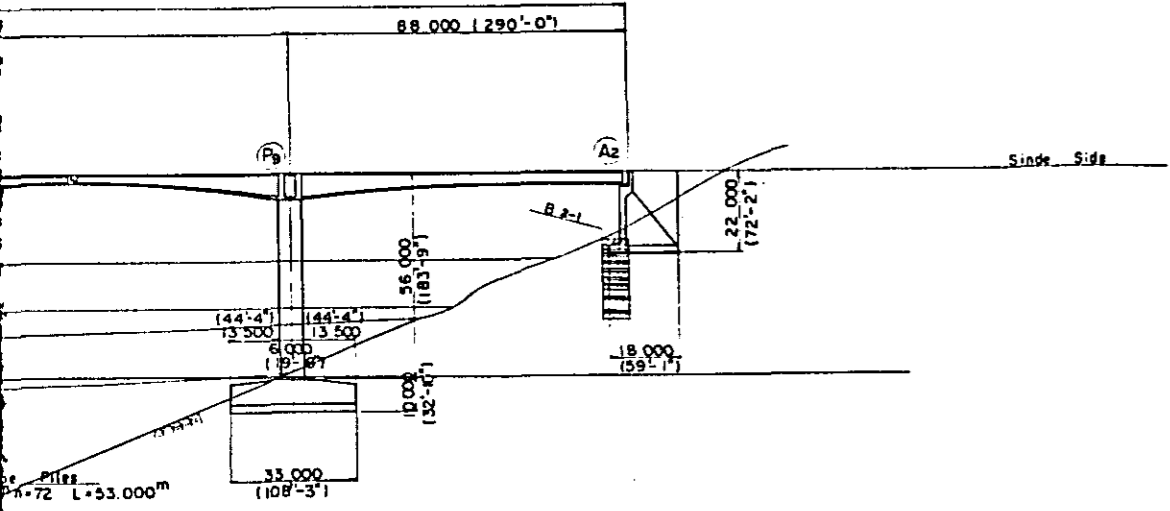
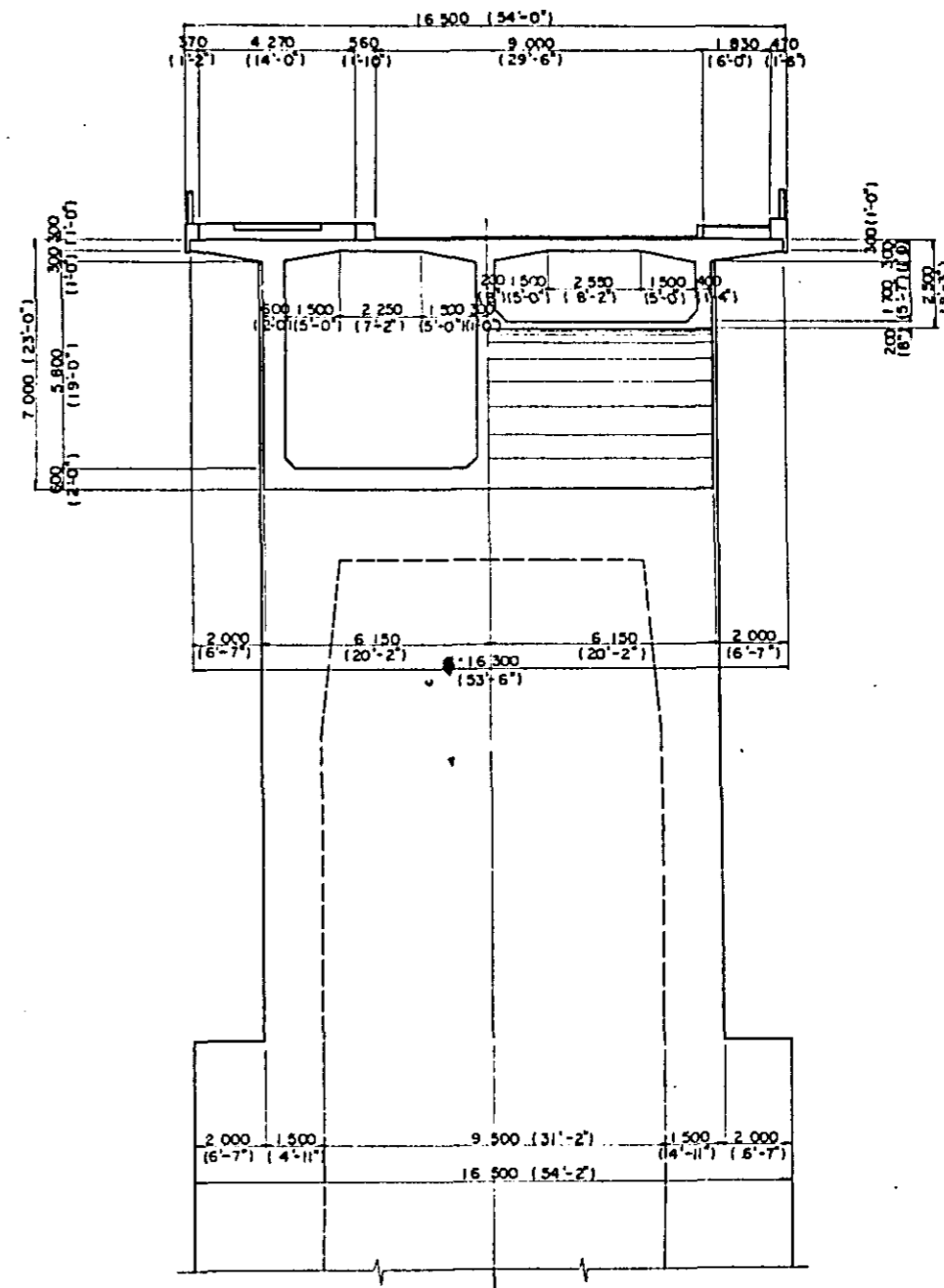



# STEEL HIGHWAY-RAILWAY BRIDGE AT SITE NO. 2

## SIDE ELEVATION

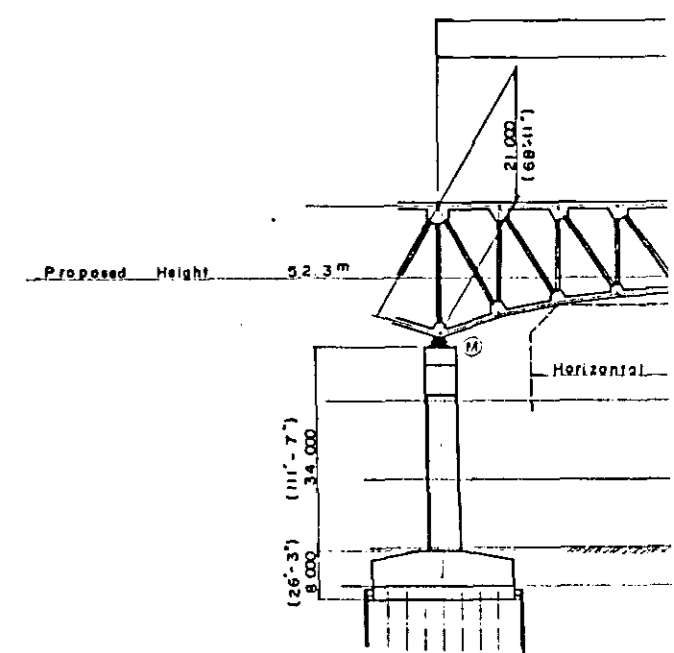
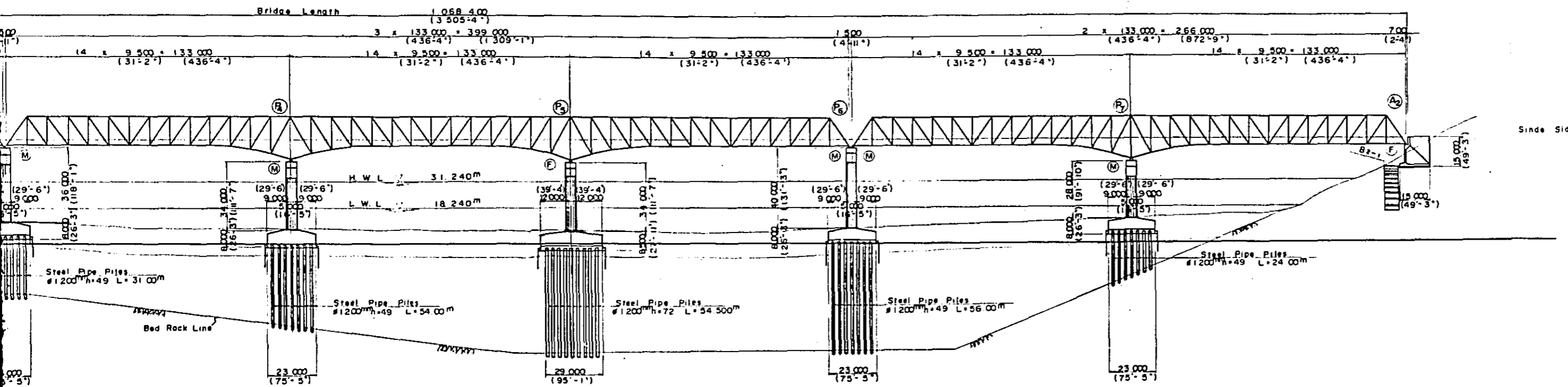

## PLAN

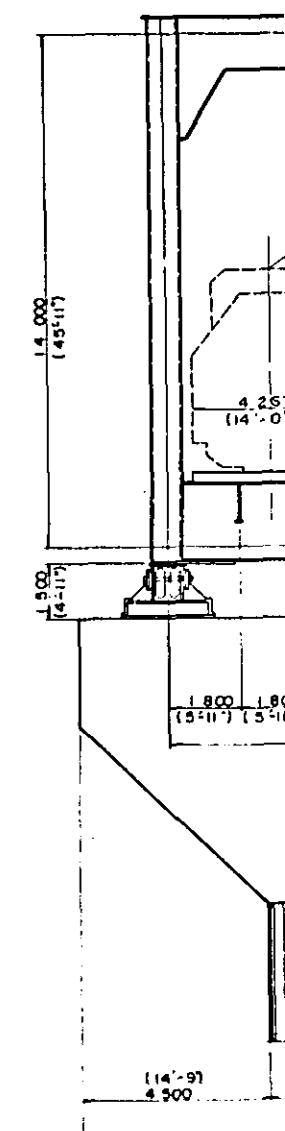
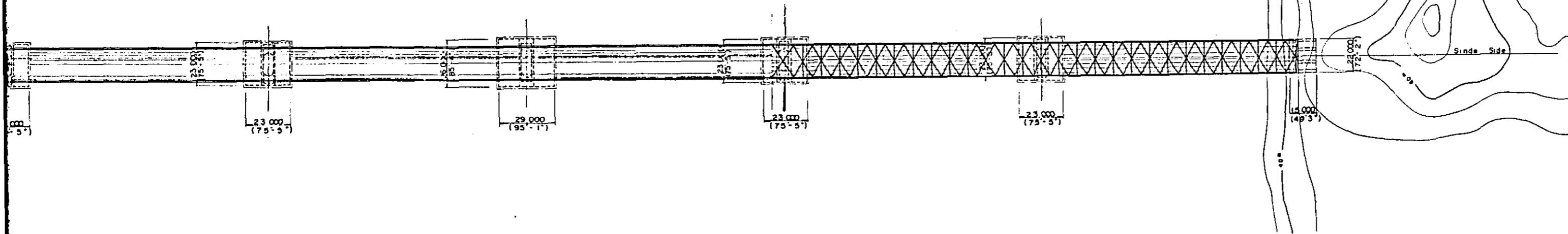

SIDE ELEVATION

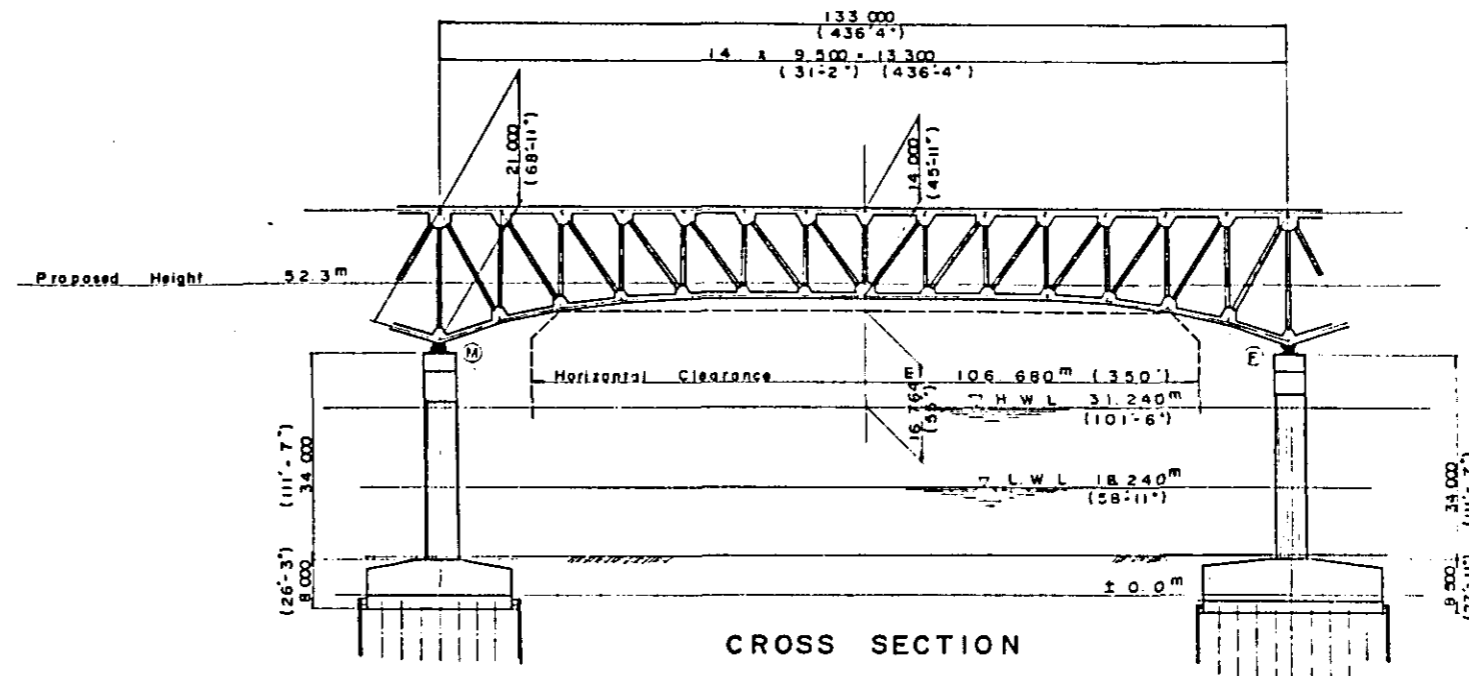

CROSS SECTION

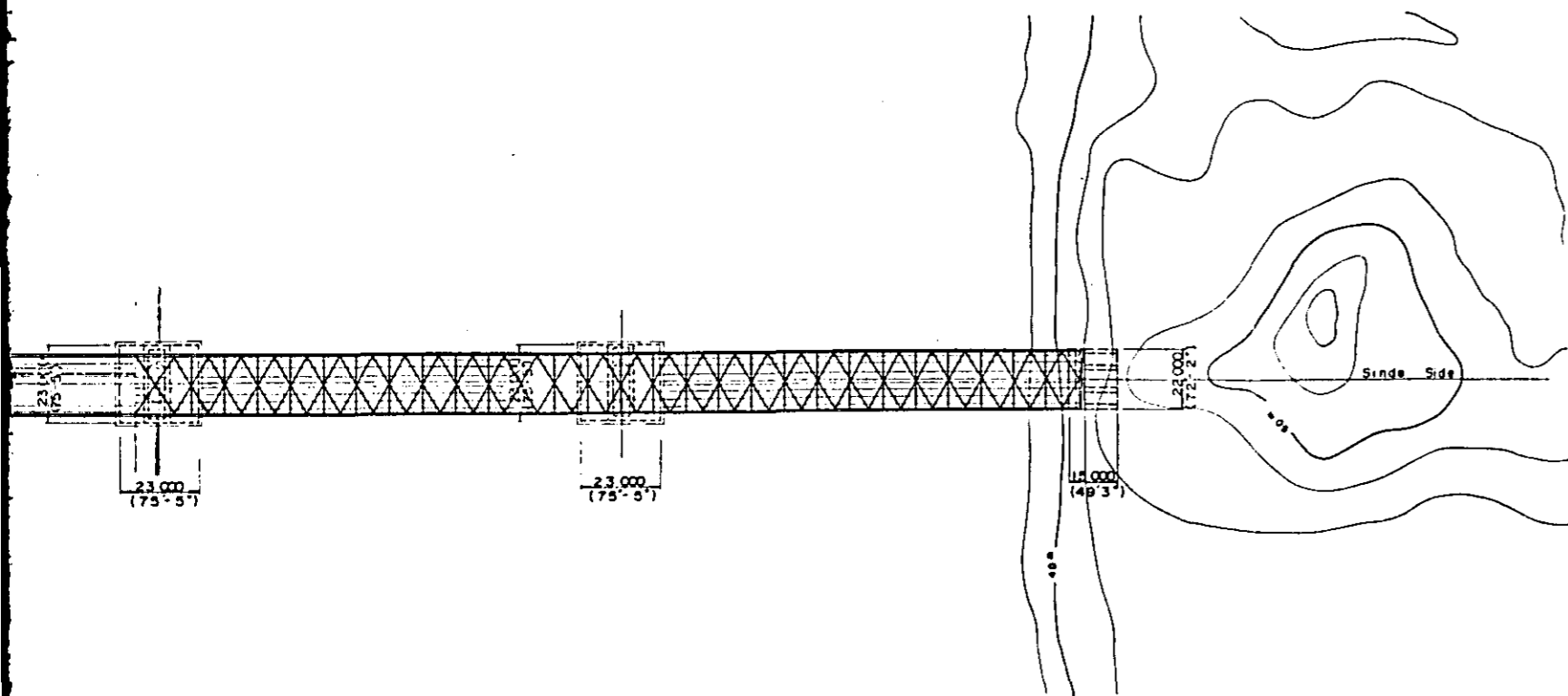
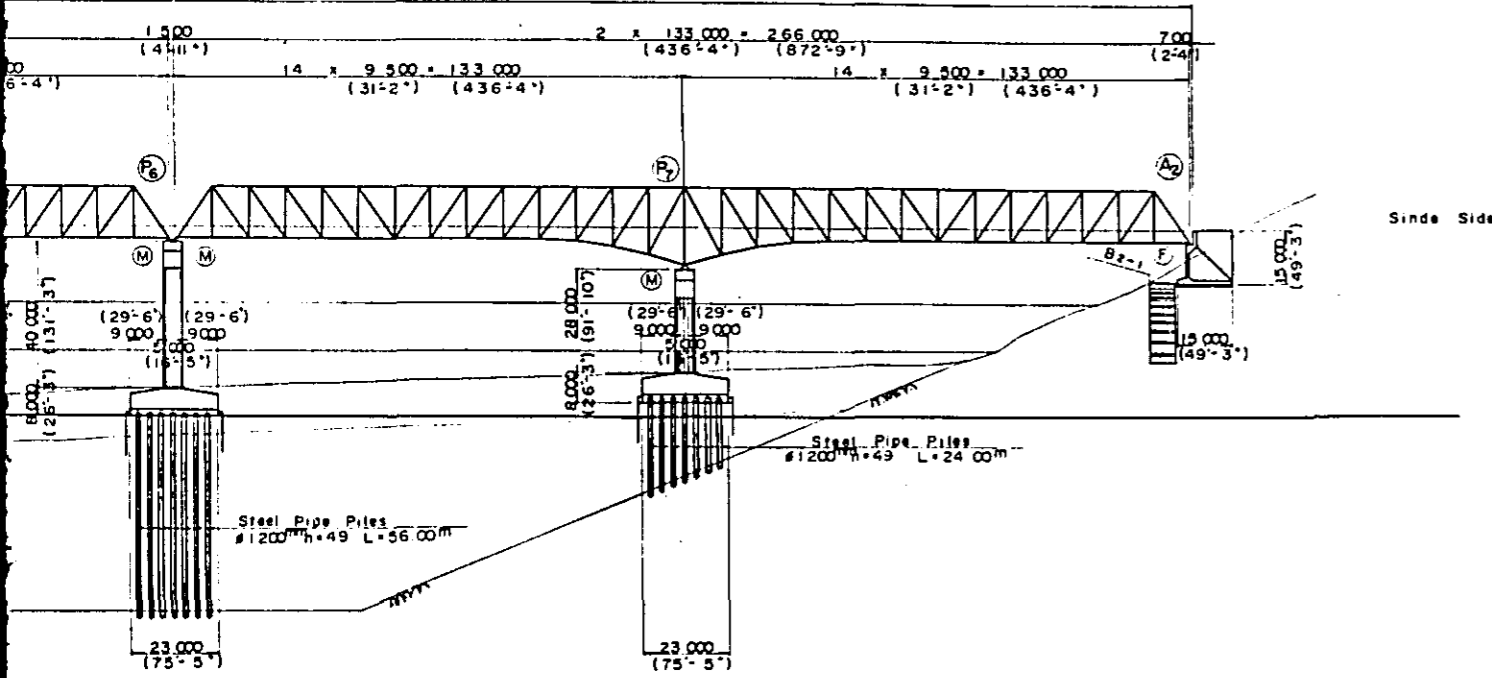
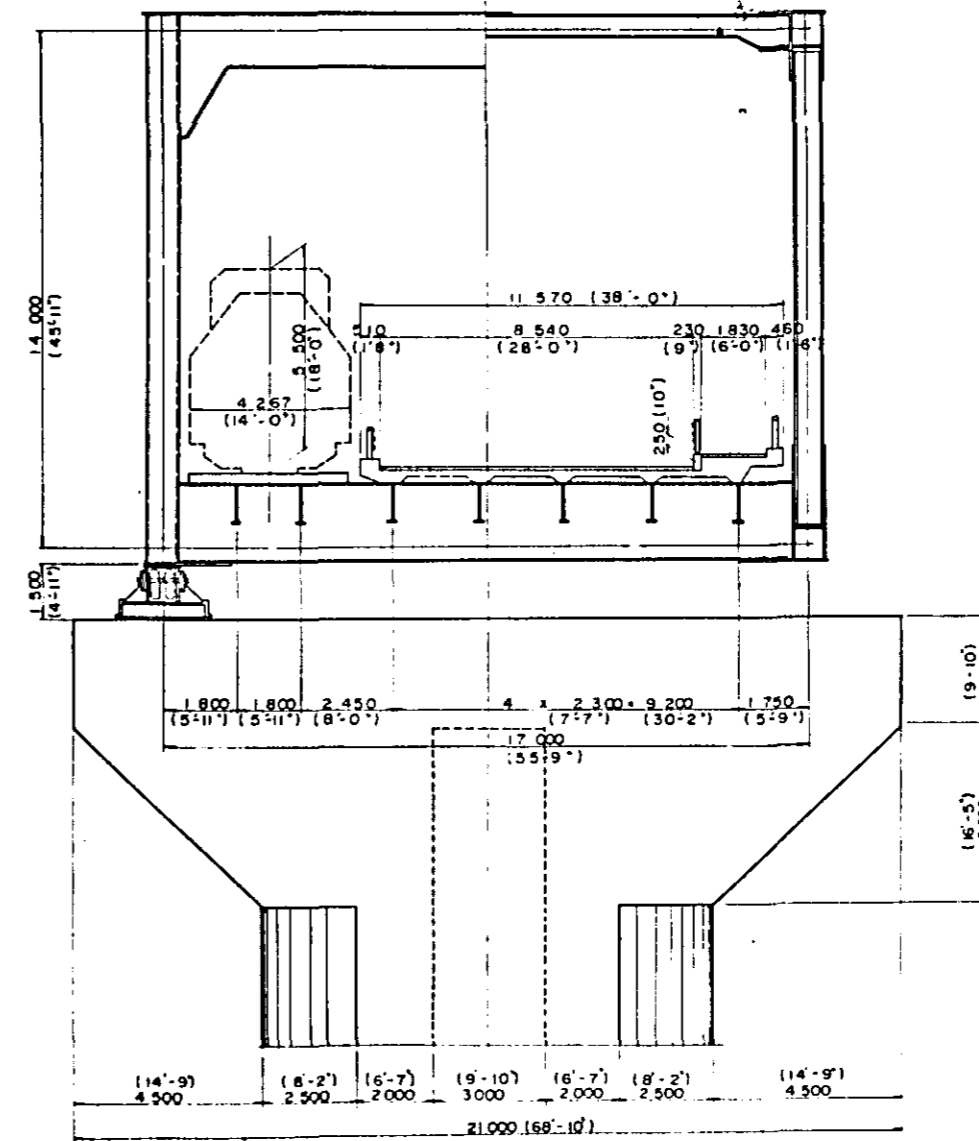

Side Side

Side Side

Side Side

Steel Pipe Piles  
 #1200mm x 49 L=24.00m

Steel Pipe Piles  
 #1200mm x 49 L=56.00m

# GENERAL SEQUENCE OF BUILDING STEEL PILE

## ① Groin

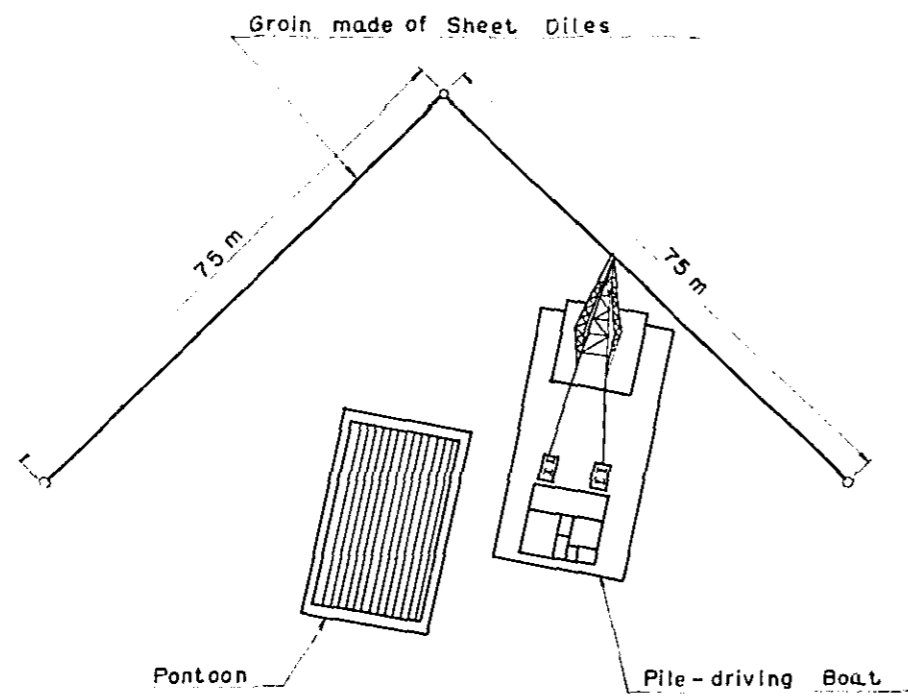
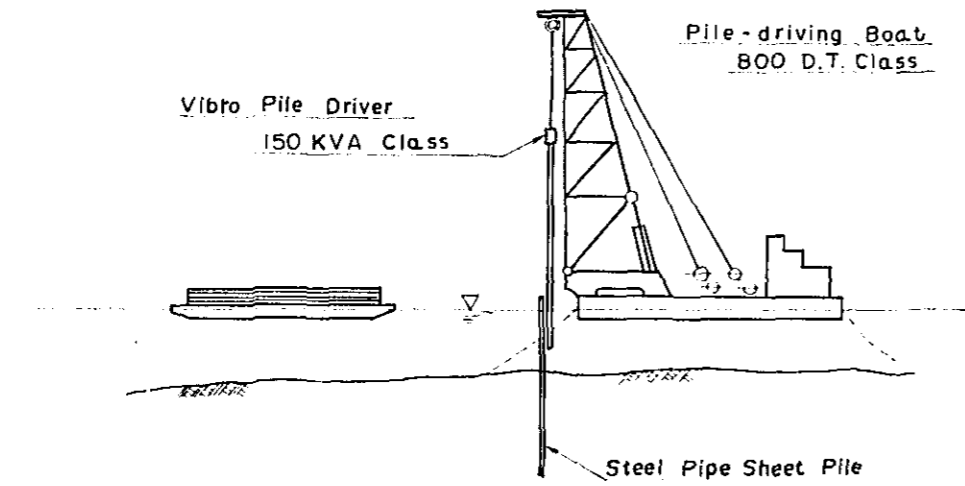

## ② Excavation of River Bed

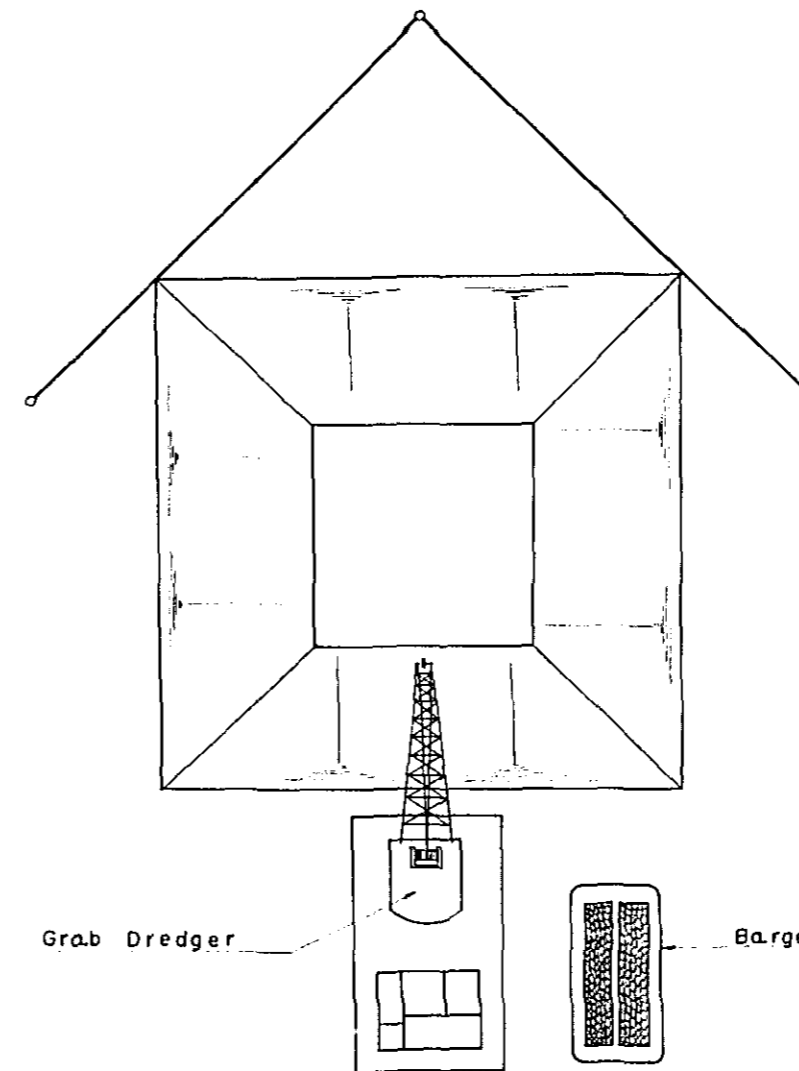
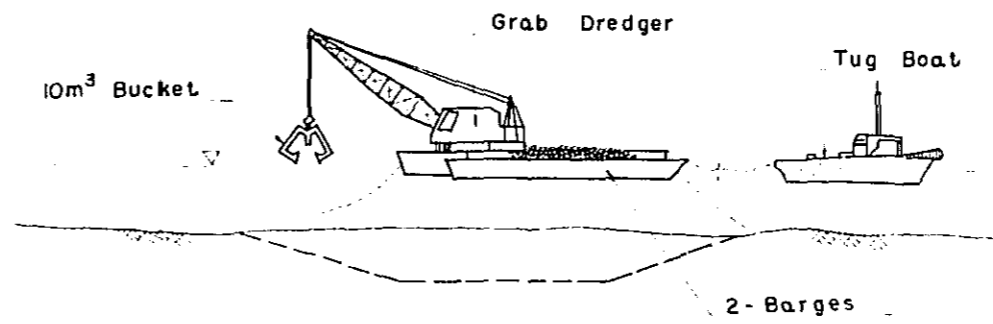

## ③ Pile Driving

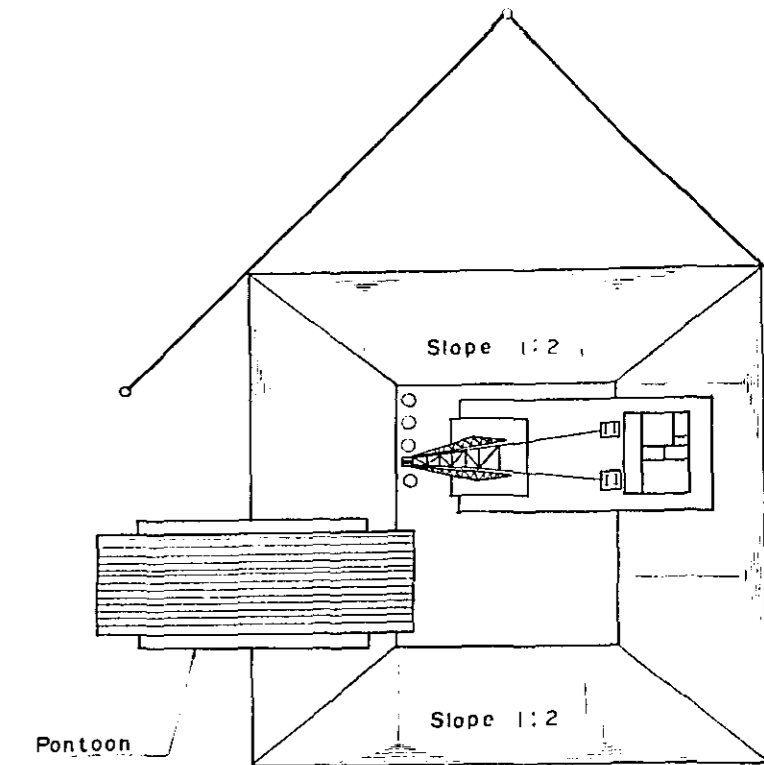
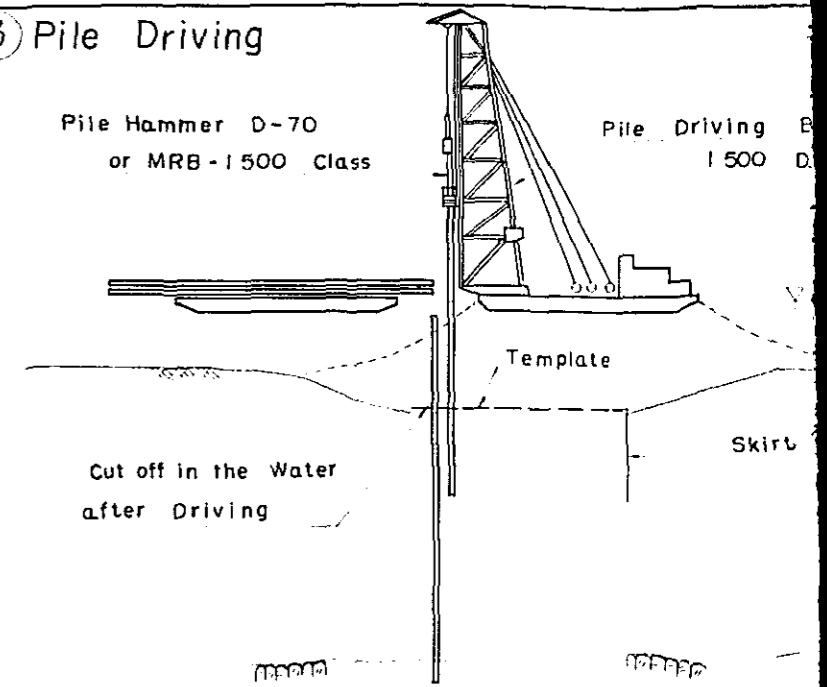



# SEQUENCE OF BUILDING STEEL PILE FOUNDATION AND PNEUMATIC CAISSON

3) Pile Driving

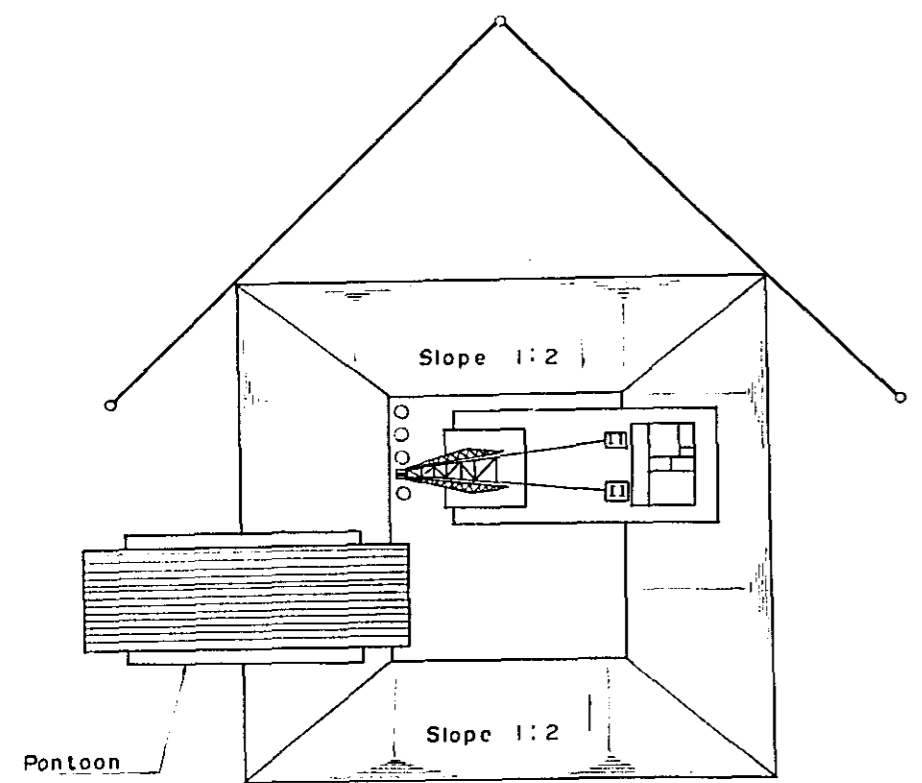
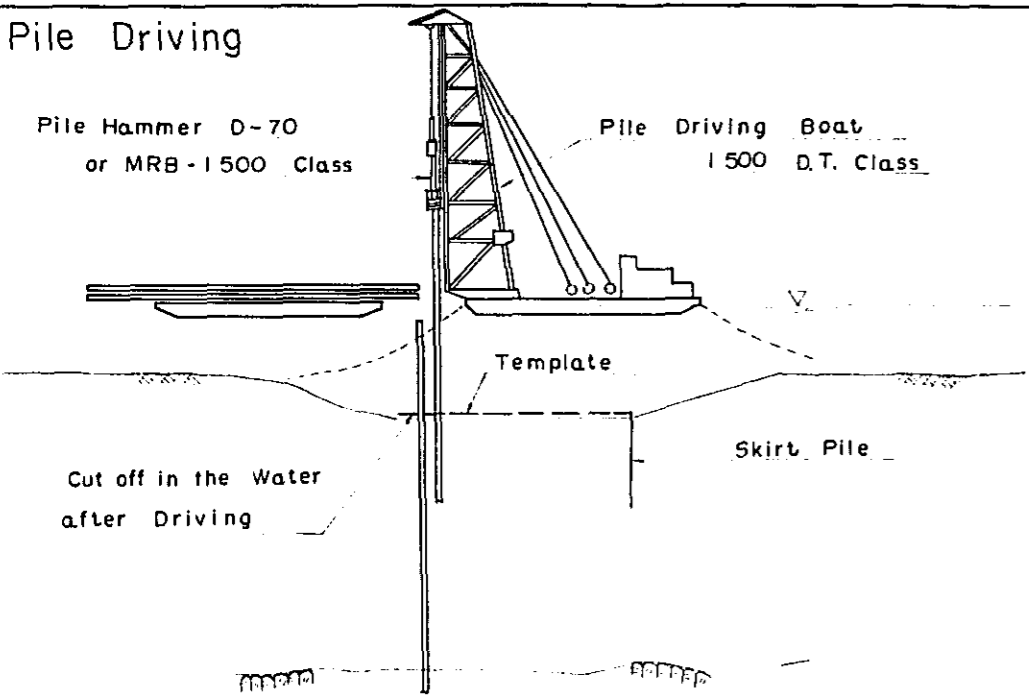

4) Installation of Pneumatic Caisson

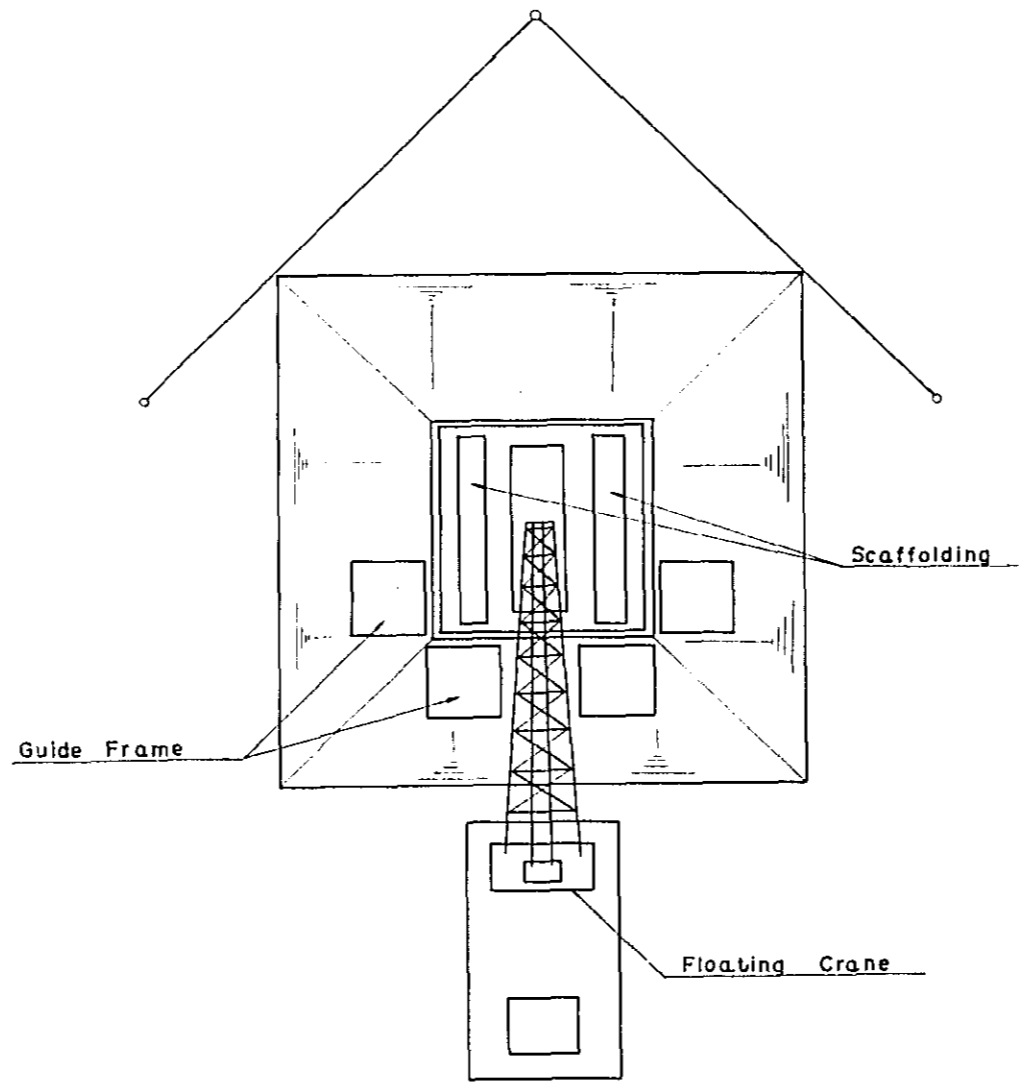
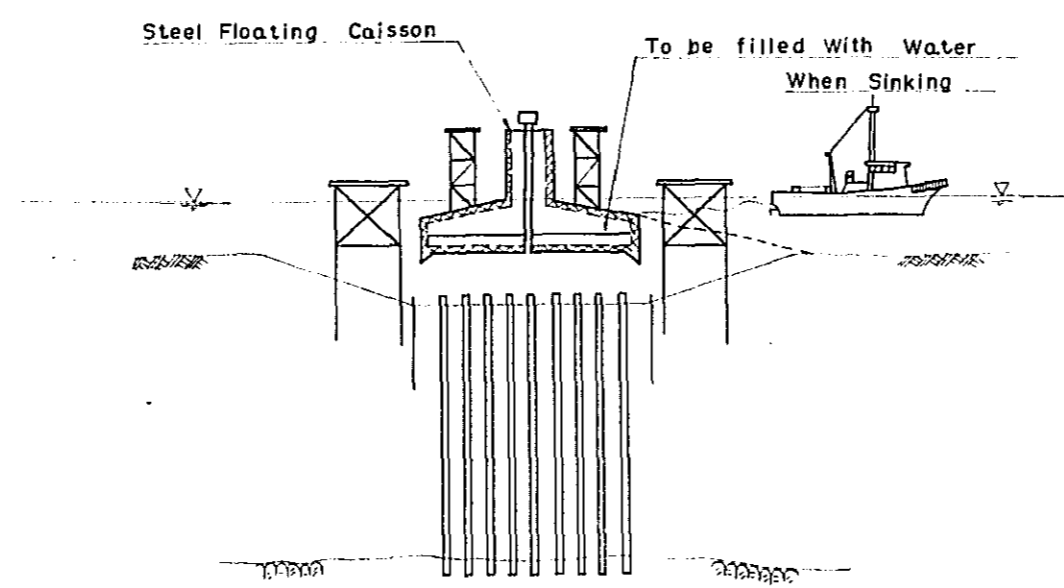

5) Treatment of Pile head and Placing of Bottom Concrete

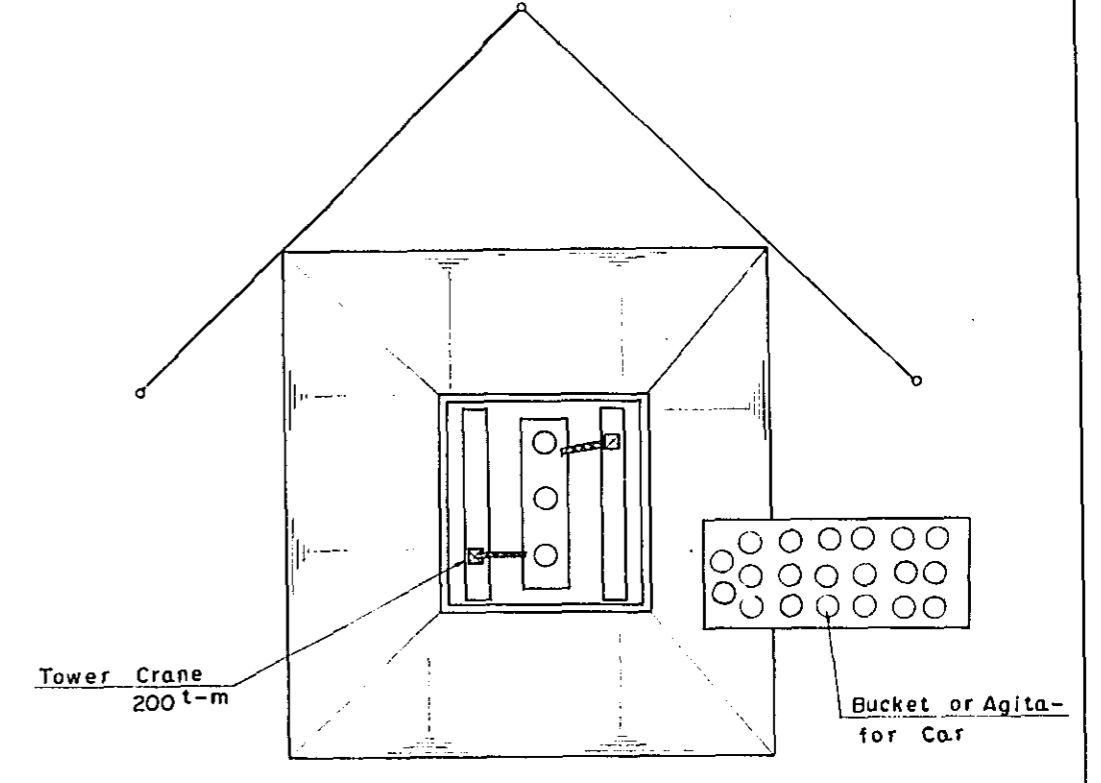
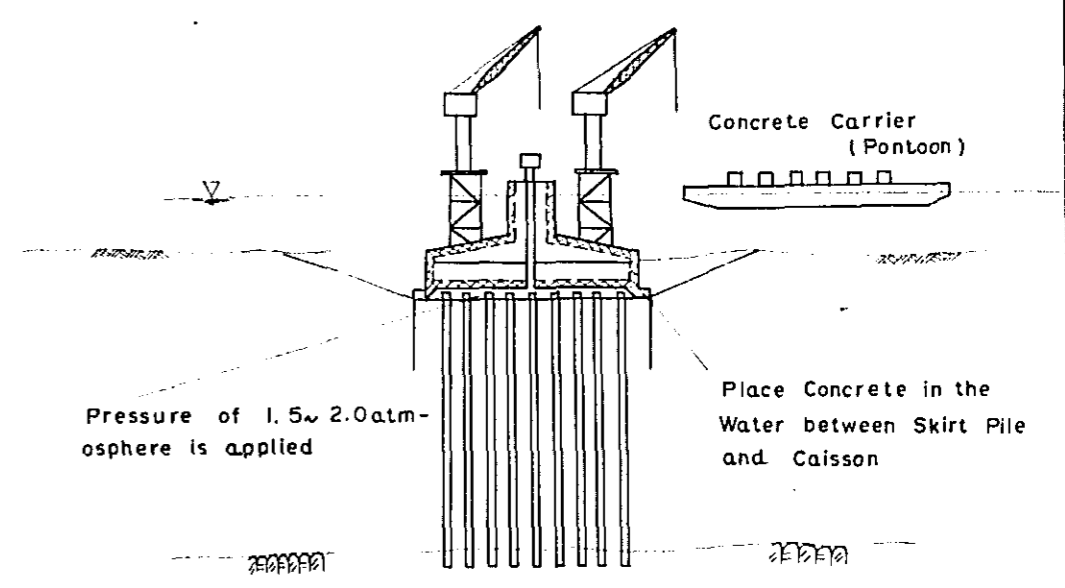

6) Const.

# D PNEUMATIC CAISSON

1) Installation of Pneumatic Caisson

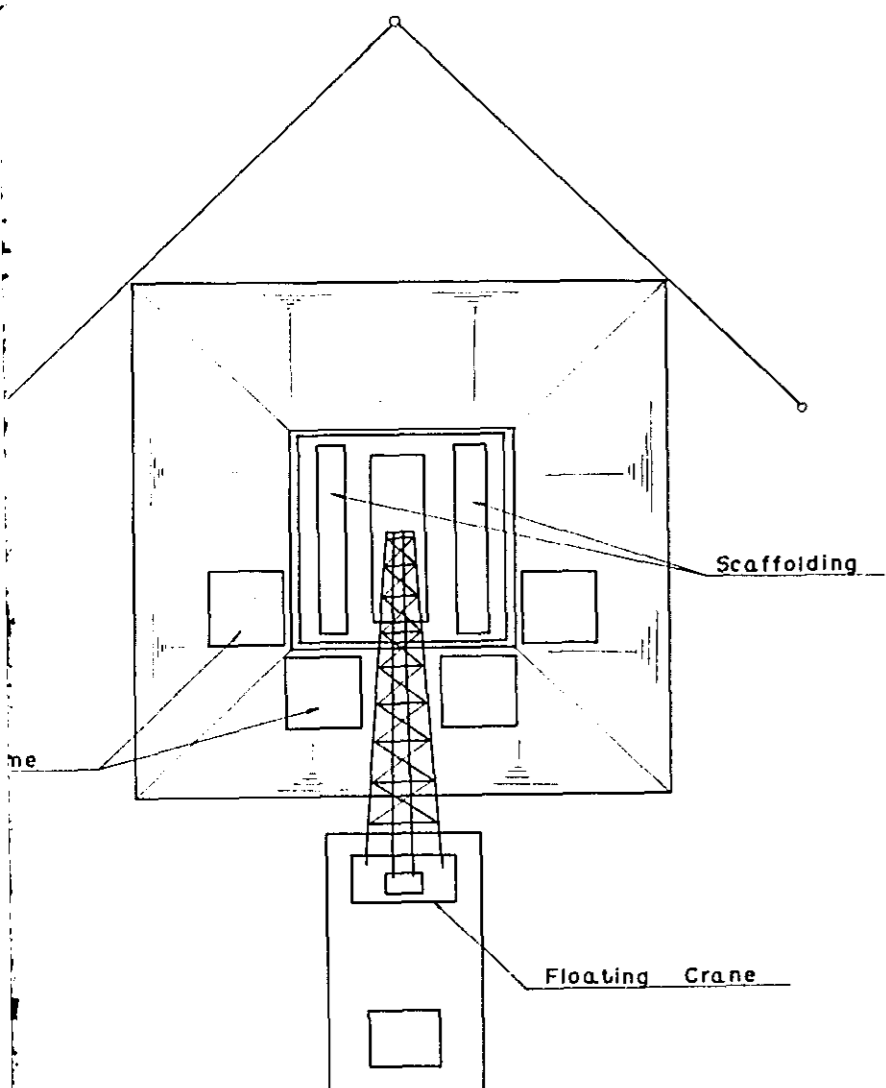
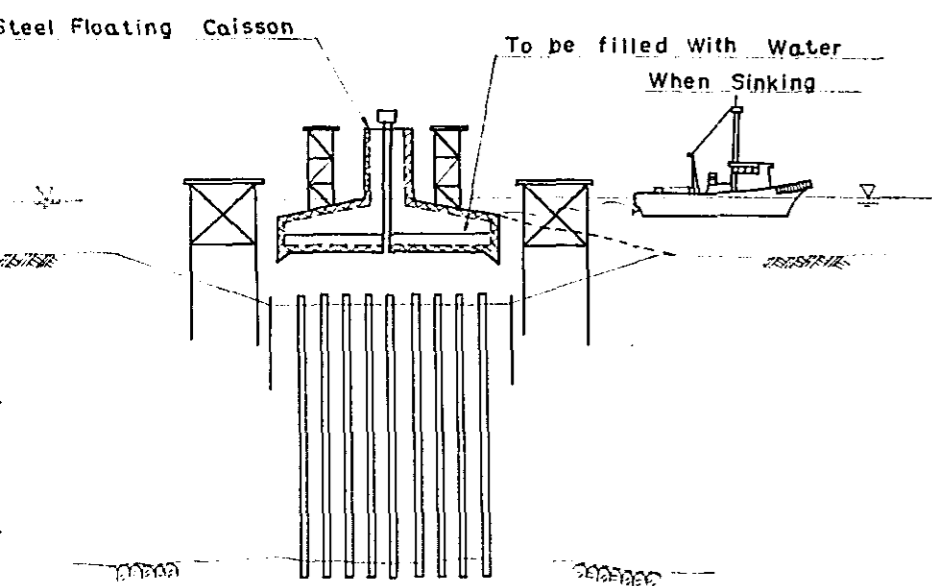

5) Treatment of Pile head and Placing of Bottom Concrete

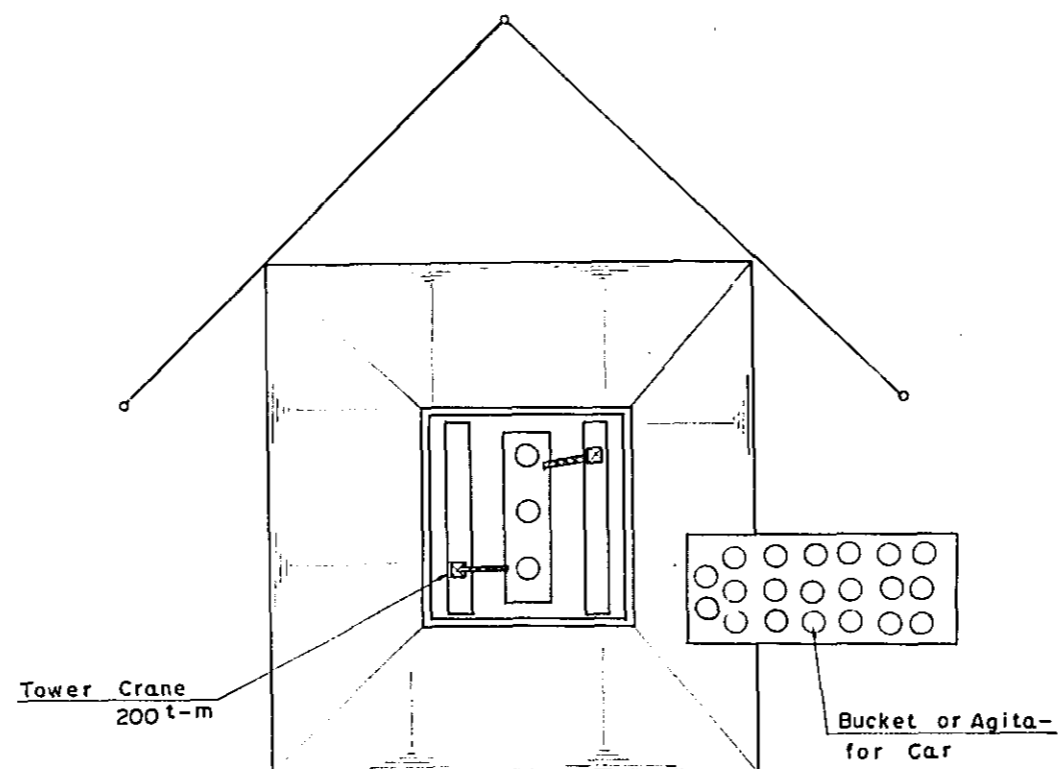
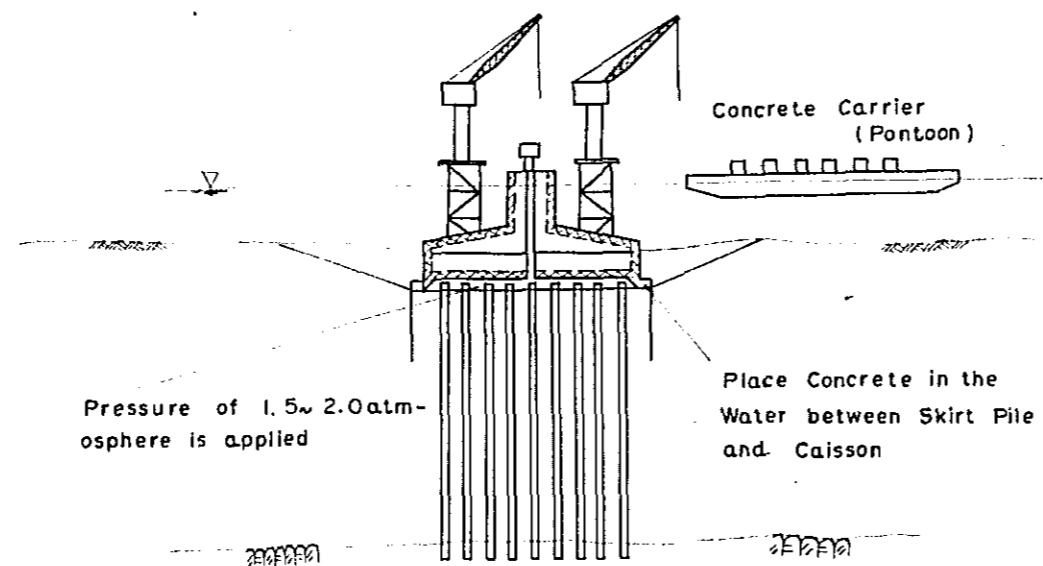

6) Construction of Pier Shaft

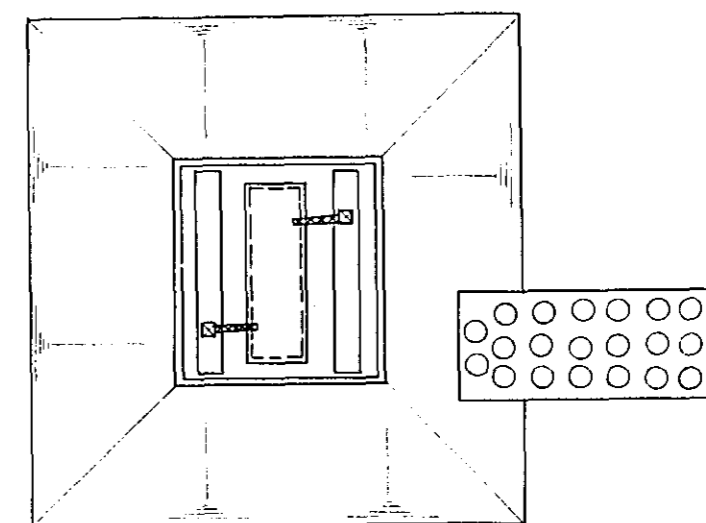
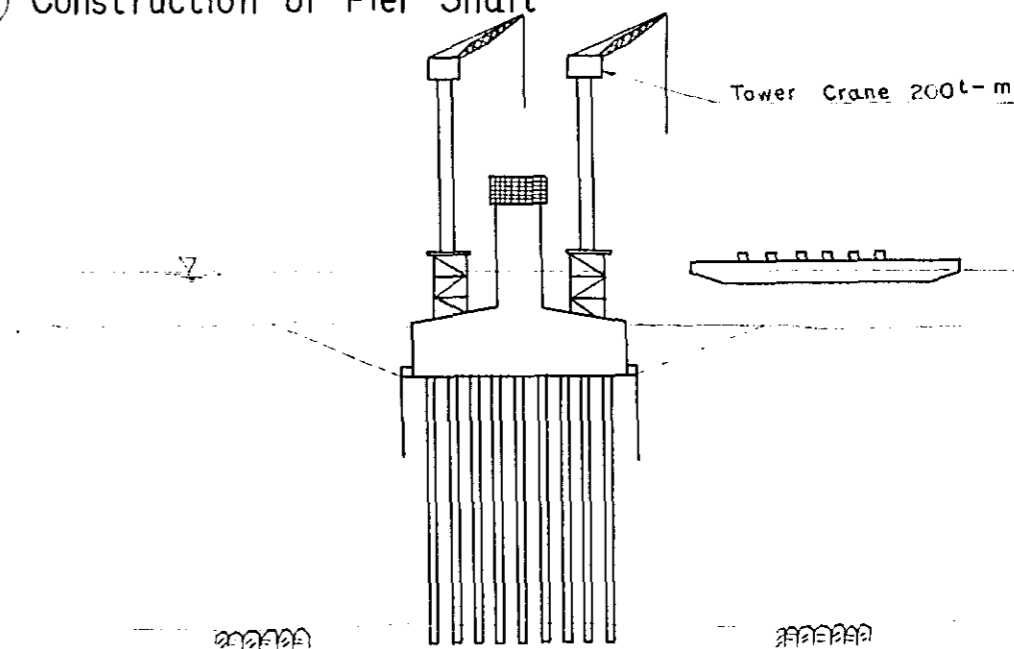

# GENERAL SEQUENCE OF BUILDING STEEL PILE FOUNDATION AND PNEUMATIC CAISSON.

## NO.11 PIER OF PRESTRESSED CONCRETE BRIDGE.

① Banking and Loosening Bed Rock

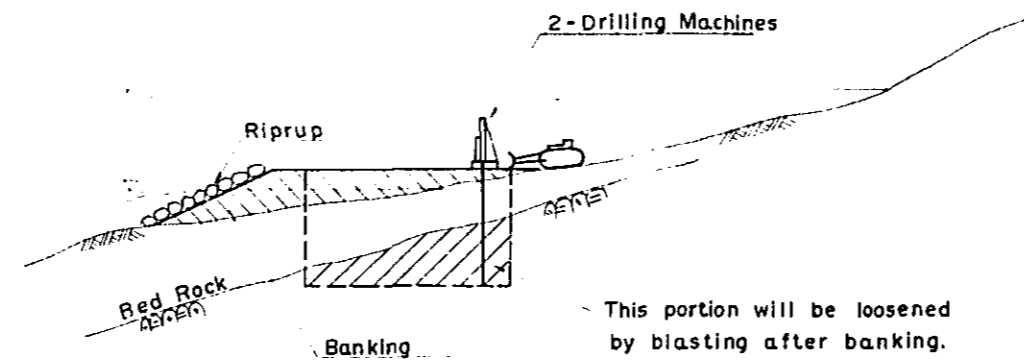

② Sinking of Pneumatic Caisson

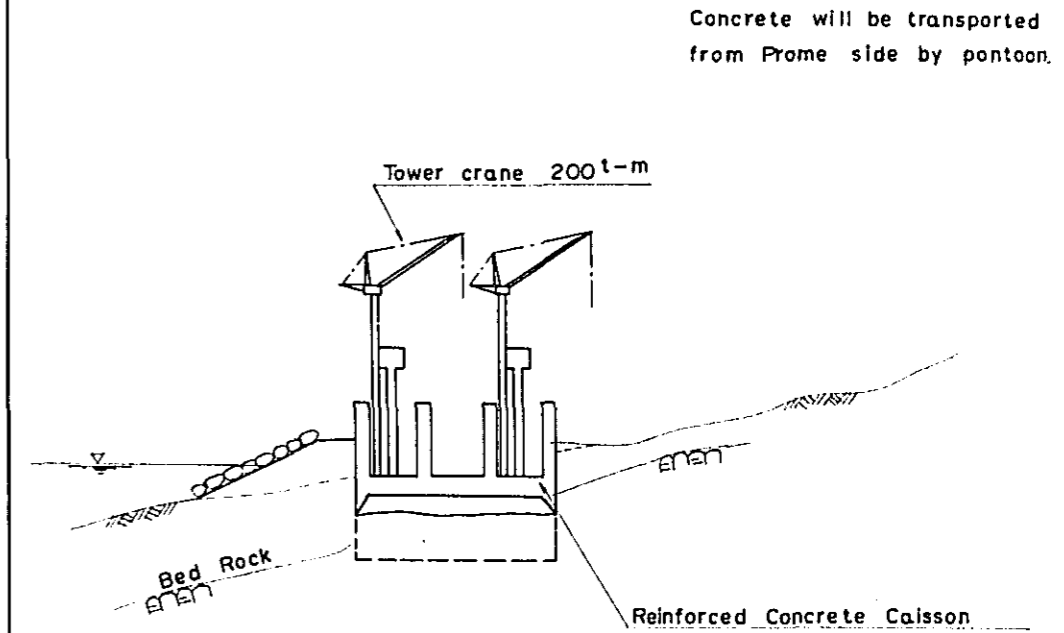

③ Constr.

## NO.9 PIER OF STEEL BRIDGE

① Excavation of River Bed

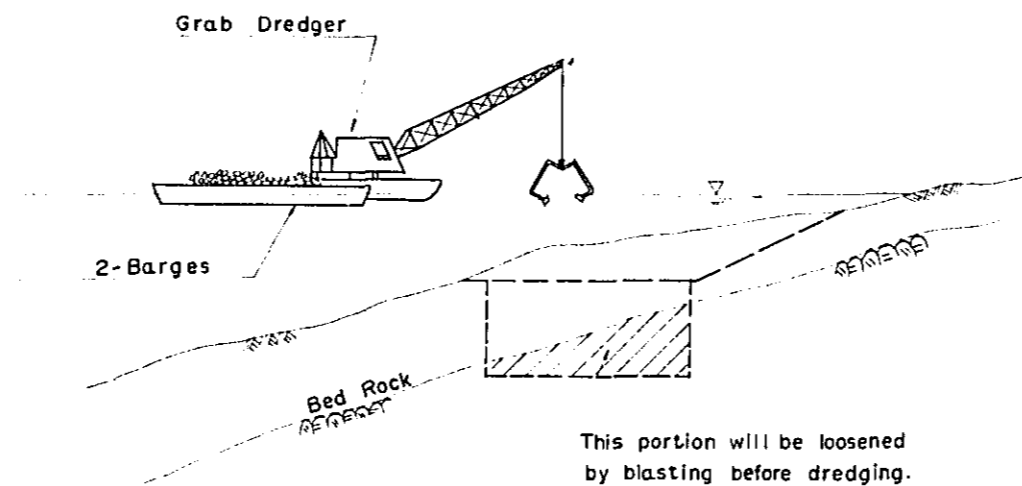

② Installation of Pneumatic Caisson

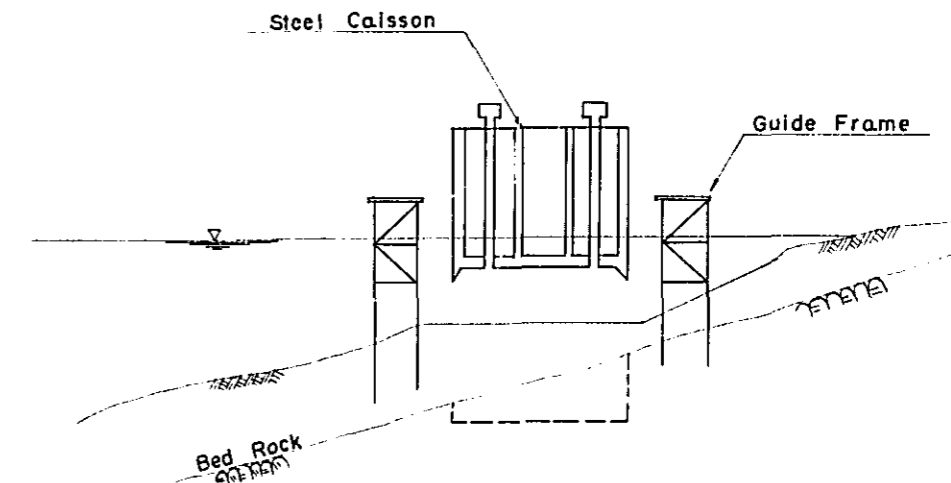

③ Constr.

# GENERAL SEQUENCE OF BUILDING STEEL PILE FOUNDATION AND PNEUMATIC CAISSON.

PROJECT IRRAWADDY-RIVER BRIDGE  
 SITE NO.3 FIGURE NO.8-11-2  
 SCALE

## NO.11 PIER OF PRESTRESSED CONCRETE BRIDGE.

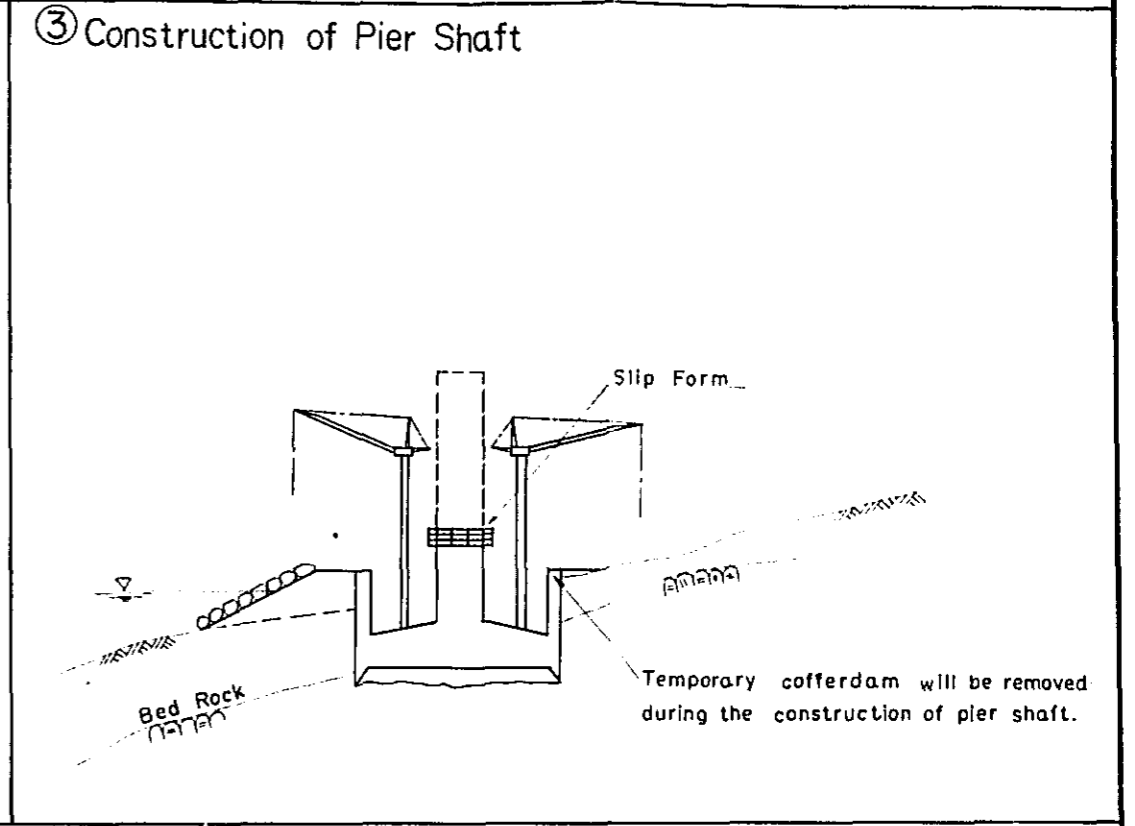
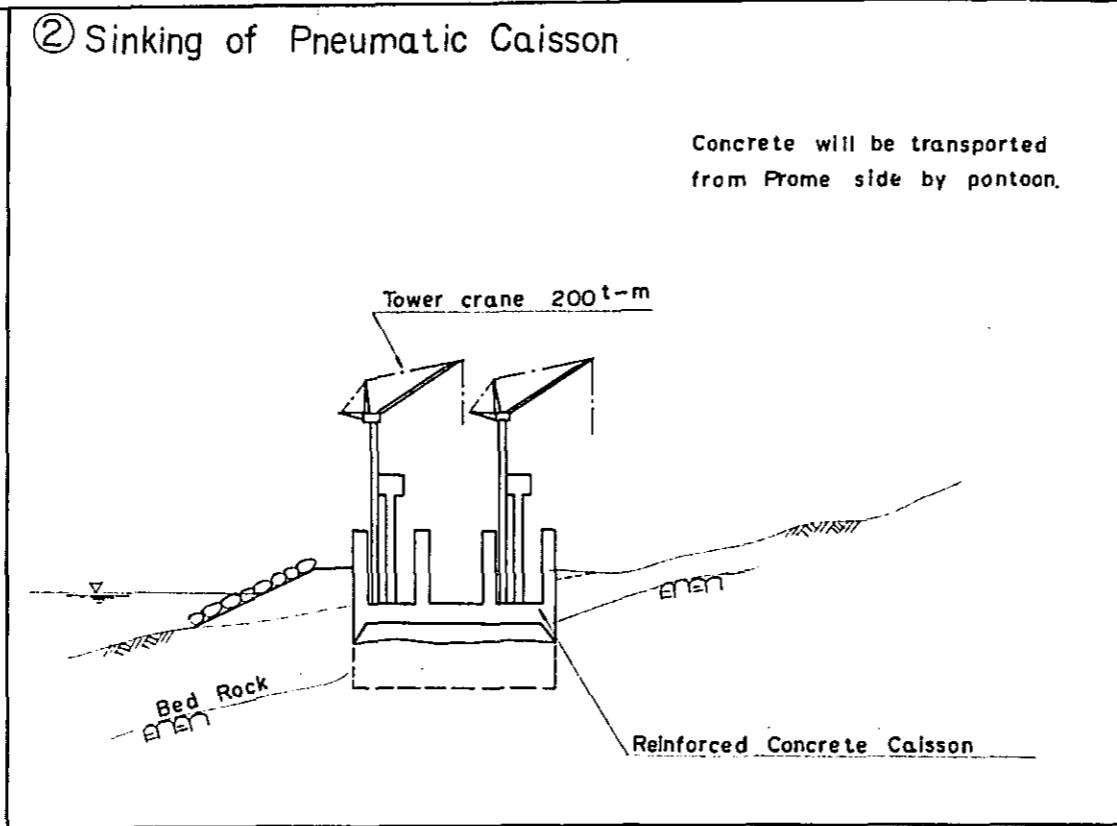
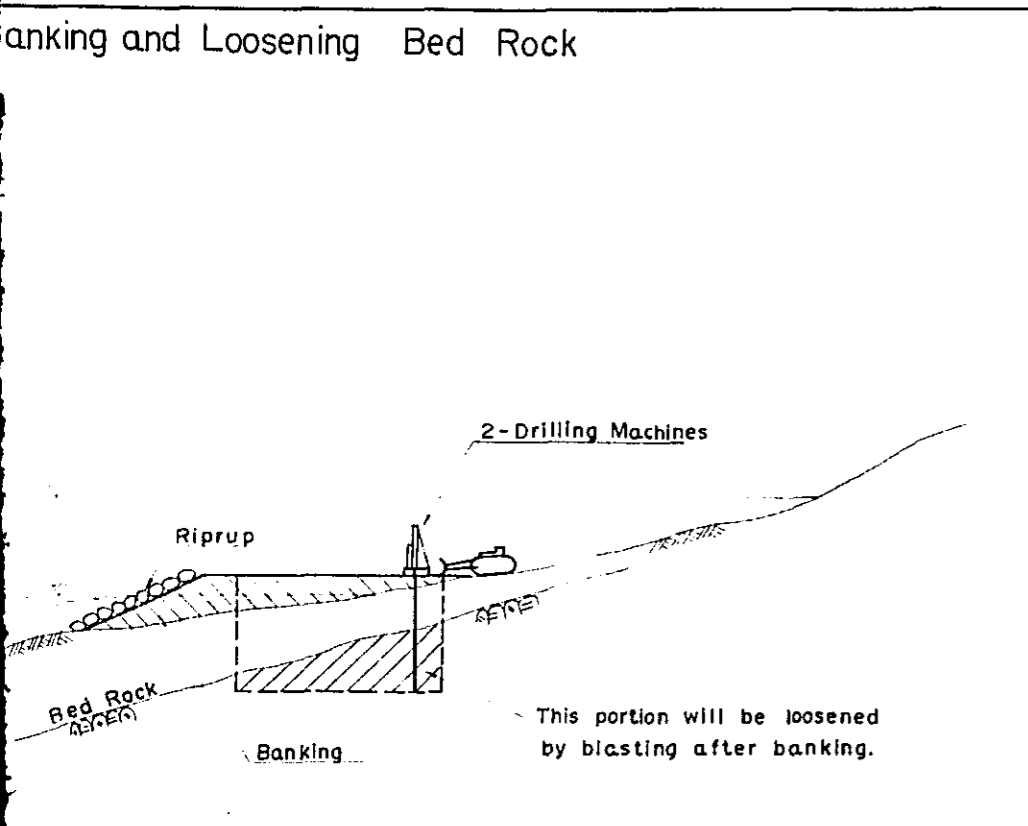

## NO.9 PIER OF STEEL BRIDGE

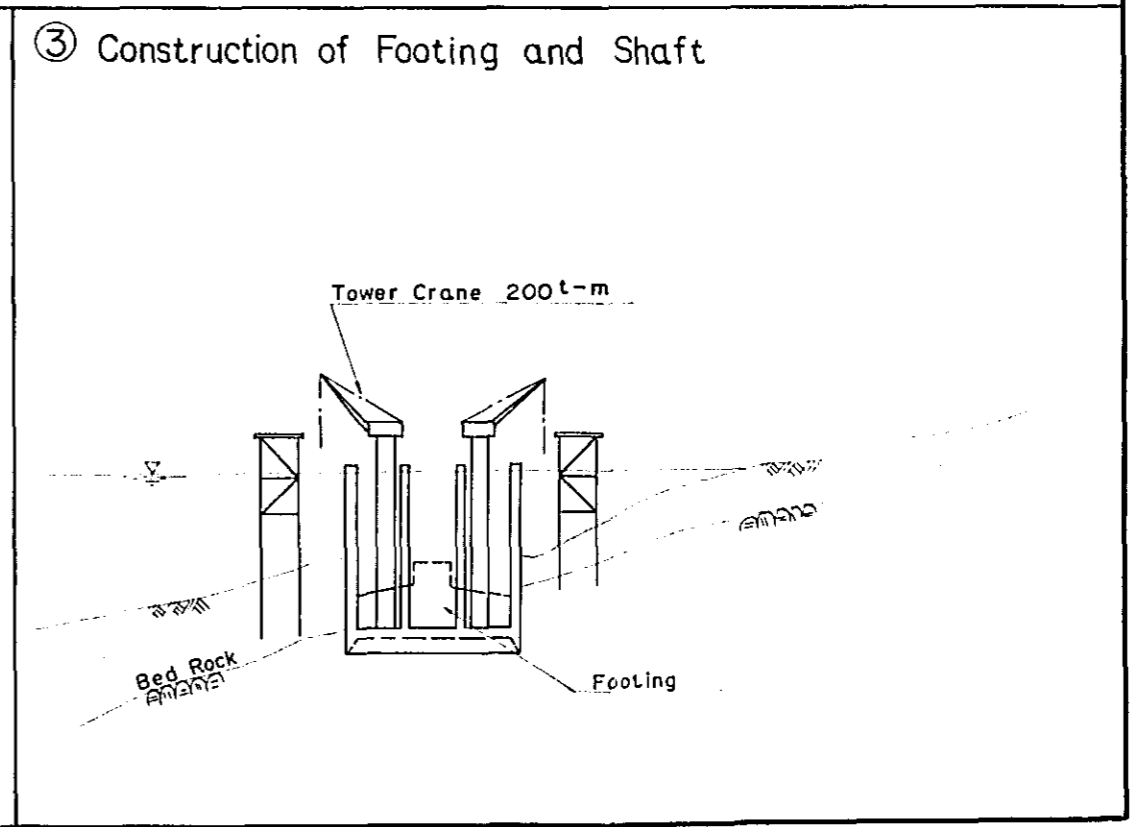
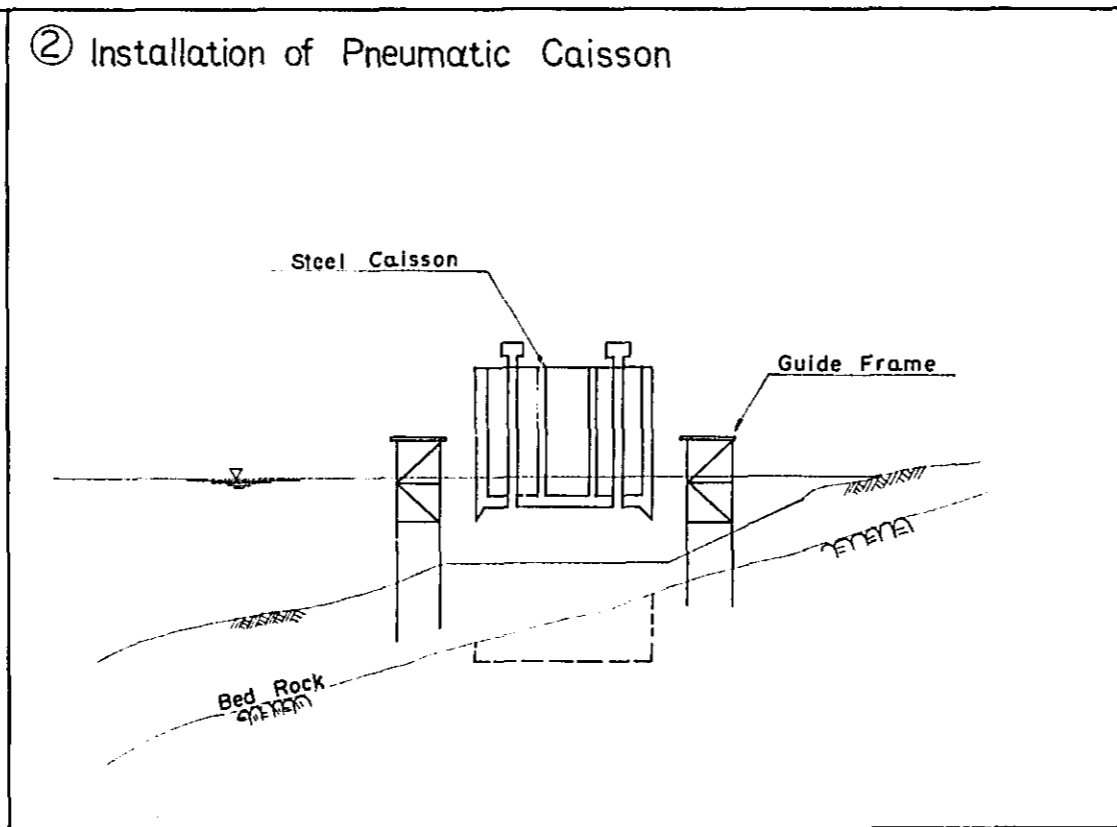
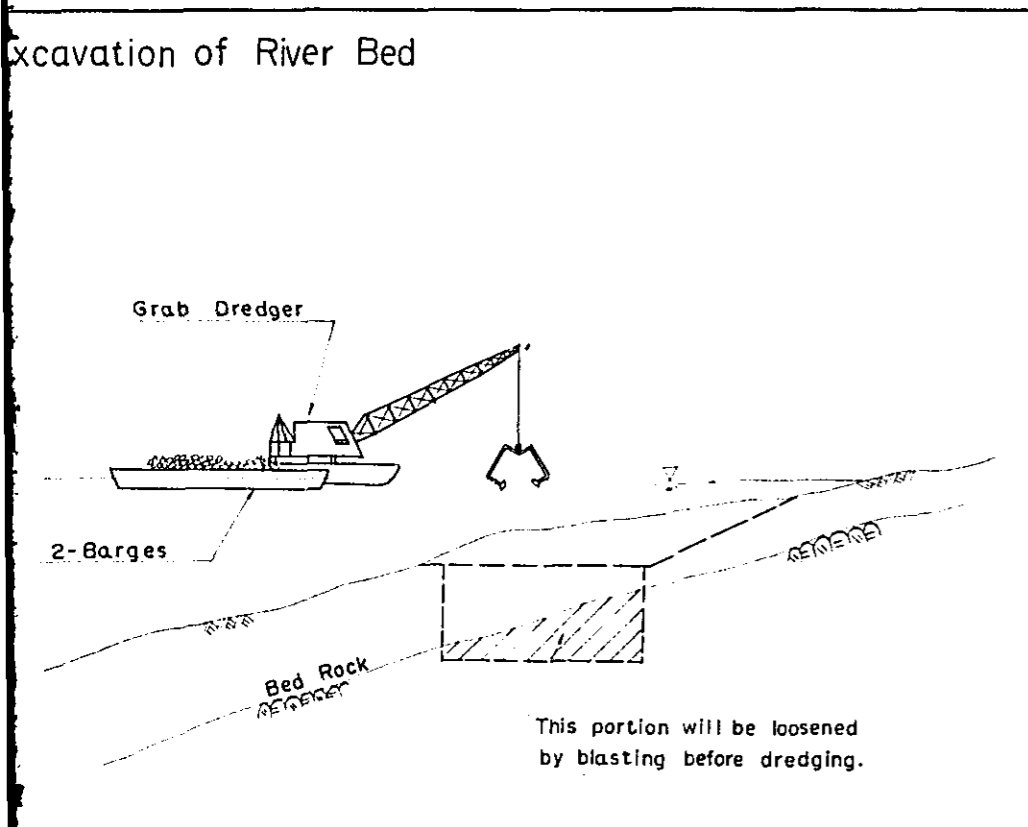











ON SCHEDULE FOR PRESTRESSED CONCRETE HIGHWAY-RAILWAY BRIDGE AT SITE NO.3

PROJECT	IRRAWADDY RIVER BRIDGE	
SITE NO.	3	FIGURE NO. 8-13
SCALE	V = 1:	H = 1:

Construction Year	4th Construction Year										5th Construction Year										6th Construction Year										7th Construction Year										8th Construction Year										9th Construction Year										Machinery and Equipment			
1	2	3	4	5	6	7	8	9	10	1	2	3	4	5	6	7	8	9	10	1	2	3	4	5	6	7	8	9	10	1	2	3	4	5	6	7	8	9	10	1	2	3	4	5	6	7	8	9	10	1	2	3	4	5	6	7	8	9	10	1	2	3	4	
																																																						Wagon (Ordinary Type)	8	Turbine Pump	7							
																																												Tower Crane	4	Freyssinet Jack (For 12+13 & 12ø7)	12+10																	
																																												Power Reach	4	Freyssinet Pump For 12+13 & 12ø7)	12+10																	
																																												Crawler Crane	1	Glouting Pump	5																	
																																												Hydraulic Crane	2	Glouting Mixer	5																	
																																												Truck 8 <sup>t</sup>	1																			
																																												Truck 6 <sup>t</sup>	2																			
																																												Truck 4 <sup>t</sup>	1																			
																																												Dump Truck 4 <sup>t</sup>	1																			
																																												Barge 600 <sup>t</sup>	1																			
																																												Truck 100 <sup>t</sup>	2																			
																																												Truck 30 <sup>t</sup>	2																			
																																												Z - Craft 50 <sup>t</sup>	2																			
																																												Tug - boat 60 <sup>t</sup>	1																			
																																												Compressor 100 HP	10																			
																																												Pile Driving Boat 1500 <sup>t</sup>	1	Derrick Crane 200 <sup>t</sup>	4																	
																																												Truck 800	1	Compressor 170 <sup>PS</sup>	5																	
																																												Pontoon 2000 <sup>t</sup>	1	Diesel Generator 220 <sup>KVA</sup>	2																	
																																												Truck 1500	1	Slip Form	4																	
																																												Truck 500	2	Drilling Machine 3 1/2	3																	
																																												Tug Boat 1000 <sup>PS</sup>	1	Winch Pump etc.																		
																																												Truck 600	2	Clamshell Grabbing Crane 3 <sup>m</sup>	4																	
																																												Truck 300	1	Dump Truck 15 <sup>t</sup>	8																	
																																												Anchor Boat 20 <sup>t</sup>	1	Bulldozer 21	2																	
																																												Truck 10	2	Concrete Pump Truck 90 <sup>m</sup> /h	2																	
																																												Diving Boat 10	1	Agilator Car 4.5 <sup>m</sup>	20																	
																																												Truck 5	2	Crawler Crane 100 <sup>t</sup>	4																	
																																												Barge 600 <sup>m</sup>	2	Heavy Truck 12 <sup>t</sup>	4																	
																																												Floating Crane 100 <sup>t</sup>	1	Bulldozer 32 <sup>t</sup>	2																	
																																												Plying Boat 100 <sup>PS</sup>	2	Diesel Generator 175 <sup>KVA</sup>	2																	
																																												Grab Dredger 10	1	Truck 4	2																	
																																												Jeep	2																			

