

THE SOCIALIST REPUBLIC OF THE UNION OF BURMA

REPORT ON TELEPHONE PLANT PLANNING PROJECT

ANNEX III

MAYANGON EXCHANGE OFFICE

(OUTSIDE PLANT)

OCTOBER 1976









JAPAN INTERNATIONAL COOPERATION AGENCY

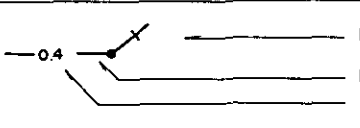

C O N T E N T S

Item Number	I t e m	Serial Number
1	Legend	
2	Key Map	III. 2. 1
3	Main Distribution Frame Plan	III. 3. 1
4	Guide Map of Subscriber Underground Cable Route	III. 4. 1
5	Subscriber Underground Cable Plan	III. 5. 1
6	Allotment Plan Of Subscriber Underground Cable Unit Number	III. 6. 1
7	Diagram of Subscriber Underground Cable	III. 7. 1
8	Index Map of Subscriber Aerial Cable Plan	III. 8. 1
9	Subscriber Aerial Cable Plan	III. 9. 1/27 5 III. 9. 27/27
10	Guide Map of Junction Cable Route	III. 10. 1
11	Diagram of Junction Cable & Loading Plan	III. 11. 1
12	Diagram of Cable Laying in Manhole	III. 12. 1/4 5 III. 12 4/4

L E G E N D

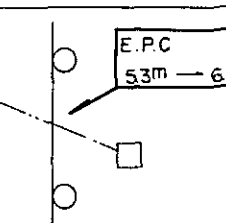
	I t e m	I t e m.																					
N O T E	<p>— Thin Line, Mark & Figure --- Existing</p> <p>— Thick Line, Mark & Figure --- Proposed</p> <p>× mark ----- Removal</p>																						
	<p>K E Y</p> <p> Riser Cable Main Cable Main Cable Conductor Diameter in mm.</p> <p>----- Aerial Cable</p> <p>----- Boundary of Distribution Block</p> <p>----- Boundary of Exchange Area</p> <table border="1" style="margin: 10px 0;"> <thead> <tr> <th>Cable</th> <th>Diam</th> <th>km</th> <th>dB</th> <th>ohm</th> <th></th> </tr> </thead> <tbody> <tr> <td>Main</td> <td>0.4</td> <td>2.9</td> <td>5.3</td> <td>818</td> <td>Main ; Main Cable (Underground Cable)</td> </tr> <tr> <td>Distribution</td> <td>0.4</td> <td>0.7</td> <td>1.3</td> <td>195</td> <td rowspan="2">Distribution ; Distribution Cable</td> </tr> <tr> <td>Total</td> <td>3.6</td> <td>6.6</td> <td>1013</td> <td></td> </tr> </tbody> </table> <p style="margin-left: 40px;">Diam ; Diameter of Conductor in mm.</p> <p>km : Main ----- Distance, in Kilometer, between Exchange and Main Cable End</p> <p>Distribution ----- Distance, in Kilometer between Main Cable End and Distribution Cable End</p> <p>dB : Sending Reference Equivalent for Main and Distribution Cables</p> <p>ohm : D.C. Resistance for Main and Distribution Cables</p>		Cable	Diam	km	dB	ohm		Main	0.4	2.9	5.3	818	Main ; Main Cable (Underground Cable)	Distribution	0.4	0.7	1.3	195	Distribution ; Distribution Cable	Total	3.6	6.6
Cable	Diam	km	dB	ohm																			
Main	0.4	2.9	5.3	818	Main ; Main Cable (Underground Cable)																		
Distribution	0.4	0.7	1.3	195	Distribution ; Distribution Cable																		
Total	3.6	6.6	1013																				
M A P		<p>P O L E</p> <p>○ Burmese Standard Pole</p> <p>⊕ Japanese Standard Pole</p> <p>Ⓛ Rail Pole</p> <p>Ⓜ Wooden Pole</p> <p>⊙ Burmese Turbular Pole</p> <p>□ Electric Power Pole</p> <p>(A4BC) Type of Burmese Standard Pole</p> <p>7.5-2 Type of Japanese Standard Pole</p> <p>7.5 ----- Pole length in meter</p> <p>2 ----- Type of Pole</p> <p>○ +BC (A4BC) Partial installation A4 Should be mounted on BC Pole</p> <p>⊗ +AB (A4BC) Pole. Replacement AB Pole should be replaced with A4 BC</p> <p>△ Strut (Burmese Standard Pole)</p> <p>△ Strut (Japanese Standard Pole)</p>																					
	S U B S C R I B E R	<p>A E R I A L</p> <p>→ Stay Installation</p> <p>$\frac{30}{S}$ 30 ----- Type of Stay Wire S ----- Type of Stay Anchor</p> <p>$\frac{X}{30}$ Stay Wire should be only replaced with 30 Stay Wire</p> <p>$\frac{30}{W}$ Overroad Stay Installaton</p>																					
		<p>C A B L E</p> <p>—04-200— Aerial Cable</p> <p>0.4 -----Conductor Diameter in m.m.</p> <p>200 -----Number of Pairs.</p> <p> Riser Cable with Dam and Gas Valve</p> <p>400 -----Number of Riser Cable Pairs</p>																					
U N D E R G R O U N D	<p>—09-400 (B) — Underground Cable</p> <p>0.9 --- Conductor Diameter</p> <p>400 --- Number of Cable Pairs</p> <p>A.B.C.D ---- Name of Main Cable (Underground Cable)</p> <p>J ---- Name of Junction Cable</p> <p> Riser Cable (CST Riser Cable with dam and Gas Valve).</p> <p> Cabinet (Cross Conection Point)</p>	<p>W I R E</p> <p>--- 6 --- Self-supporting Distribution Wire</p> <p>6 -----Number of Pairs</p> <p>--- Wx1 --- Self-supporting Type Drop Wire</p> <p>Wx1 ----- One Line</p>																					
	<table border="1" style="margin: 10px 0;"> <thead> <tr> <th>B</th> <th>17</th> </tr> </thead> <tbody> <tr> <td>301 ~ 400</td> <td>17</td> </tr> <tr> <td>7</td> <td>18</td> </tr> <tr> <td>23</td> <td></td> </tr> </tbody> </table> <p>B ----- Allotment of Main Cable Pair Number</p> <p>7 ----- Number of Existing Subscriber Lines</p> <p>23 ----- Number of Existing Subscriber Lines and Applications</p> <p>17 ----- Index Number of Aerial Cable Plan</p> <p>18 -----</p>		B	17	301 ~ 400	17	7	18	23														
	B		17																				
301 ~ 400	17																						
7	18																						
23																							
<p>23090^m ----- Distance between Riser Pole and Exchange Office</p> <p>2.0 dB ----- Sending Reference Equivalent for Main and Riser Cables (excluding telephone sets)</p> <p>214.0 ohm --- D.C Resistance for Main and Riser Cables (excluding telephone sets)</p>																							
C A B L E		<p>T E R M I N A L</p> <p> Ready Access Terminal Box (200-Pair Type) Straight Type</p> <p> Ready Access Terminal Box (200-Pair Type) Single Branch Type</p> <p> Ready Access Terminal Box (200-Pair Type) Both Brantch Type</p> <p> Ready Access Terminal Box (400-Pair Type) Straight Type</p> <p> Indoor Terminal Block</p>																					
P L A N		<p>O T H E R S</p> <p>----- Boundary of Distribution Block</p> <p>----- Boundary of Exchange Area</p> <table border="1" style="margin: 10px 0;"> <thead> <tr> <th>A</th> <th>1-300</th> </tr> </thead> <tbody> <tr> <td>85</td> <td></td> </tr> <tr> <td>122</td> <td></td> </tr> </tbody> </table> <p>A1-300 ----- Allotment of Main Cable Pair Number</p> <p>85 ----- Number of Existing Subscriber Lines</p> <p>122 ----- Number of Existing Subscriber Lines & Applications</p>	A	1-300	85		122																
	A	1-300																					
85																							
122																							
<p>A S E R I A L C A B L E P L A N</p> <p> Remodelling of Power Line.</p> <p>Power Line should be lifted up 5.3m to 6.0m.</p>																							

JICA LIBRARY



1012462163

国際協力事業団

登録	L104
月日 '84.5.25	78
登録No. 07929	SD

Kind	Diam	km	dB	ohm
Main	0.5	3.1	4.2	550
Distribution	0.4	0.8	1.5	111
	0.65	0.5	0.5	53
Total		4.4	6.2	714

Kind	Diam	km	dB	ohm
Main	0.5	3.1	4.2	550
Distribution	0.5	0.7	0.9	124
	0.65	1.9	1.9	200
Total		5.7	7.0	874

Kind	Diam	km	dB	ohm
Main	0.4	1.9	3.3	516
Distribution	0.5	2.0	2.7	355
	0.65	0.4	0.4	42
	0.9	0.8	0.6	44
Total		5.1	7.0	957

Kind	Diam	km	dB	ohm
Main	0.4	2.9	5.3	818
Distribution	0.4	0.7	1.3	195
	0.5	0.7	0.5	124
Total		4.3	7.1	1137

Kind	Diam	km	dB	ohm
Main	0.4	2.9	5.3	818
Distribution	0.4	0.7	1.3	195
Total		3.6	6.6	1013

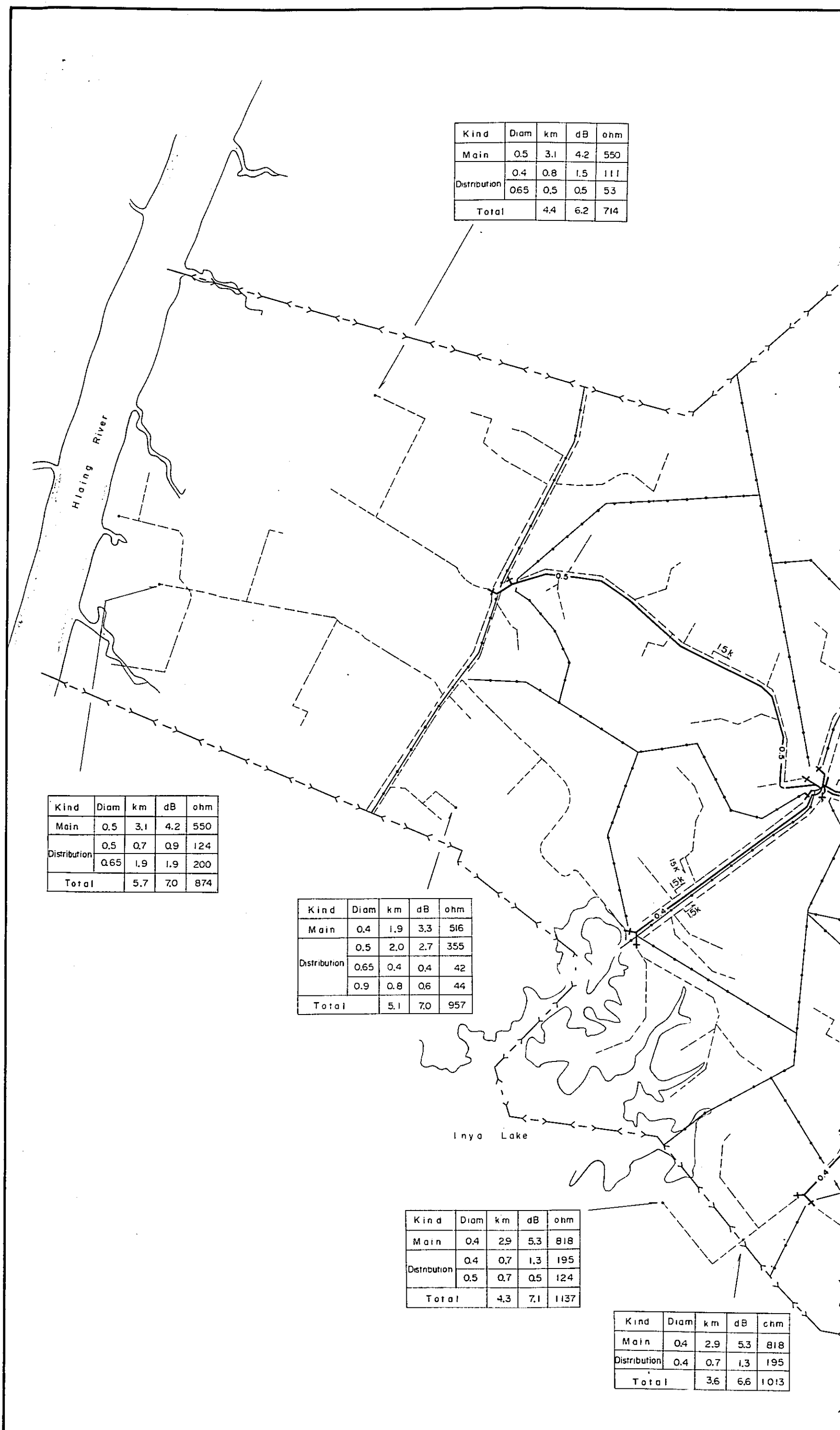

Kind	Diam	km	dB	ohm
Main	0.5	3.1	4.2	550
Distribution	0.4	0.8	1.5	111
	0.65	0.5	0.5	53
Total	4.4	6.2	714	

Kind	Diam	km	dB	ohm
Main	0.4	0.4	0.9	107
Distribution	0.4	0.7	1.3	195
	0.5	2.9	3.9	515
	0.65	0.3	0.3	32
Total	4.3	6.4	849	

Kind	Diam	km	dB	ohm
Main	0.9	4.7	3.1	263
Distribution	0.65	2.3	2.3	242
Total	7.0	5.4	505	

Kind	Diam	km	dB	ohm
Main	0.9	3.8	2.5	219
Distribution	0.4	1.0	1.8	278
	0.65	0.5	0.5	53
Total	5.3	4.8	544	

Kind	Diam	km	dB	ohm
Main	0.4	2.9	5.3	818
Distribution	0.4	0.8	1.5	223
Total	3.7	6.6	1041	

km	dB	ohm
2.9	5.3	818
0.7	1.3	195
0.7	0.5	124
4.3	7.1	1137

Kind	Diam	km	dB	ohm
Main	0.4	2.9	5.3	818
Distribution	0.4	0.7	1.3	195
Total	3.6	6.6	1013	

Kind	Diam	km	dB	ohm
Main	0.4	2.9	5.3	818
Distribution	0.4	0.8	1.5	223
	0.5	0.6	0.8	107
	0.65	0.5	0.5	53
Total	4.8	8.1	1201	

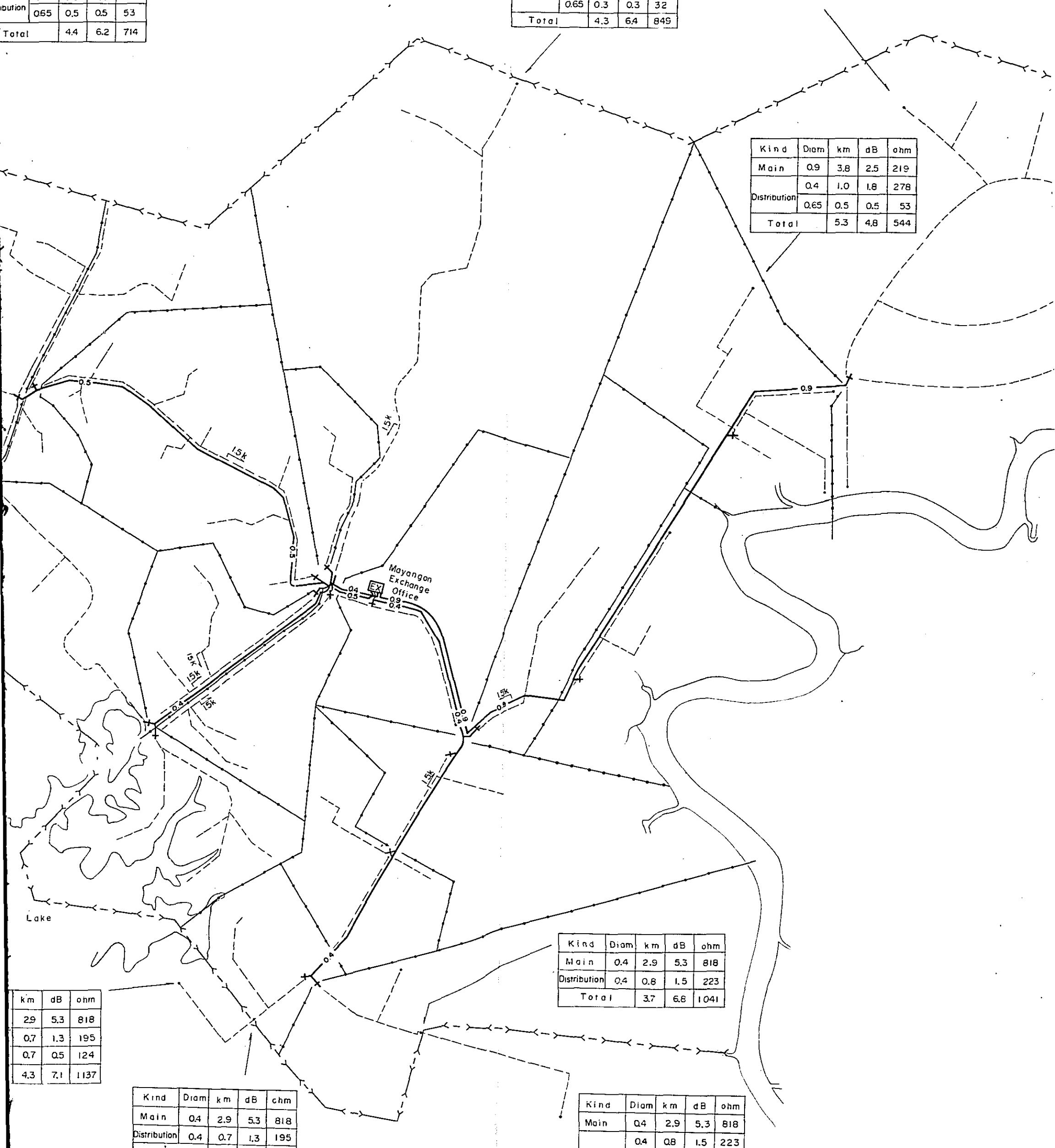

dB	ohm
0.9	107
1.3	195
3.9	515
0.3	32
5.4	849

Kind	Diam	km	dB	ohm
Main	0.9	4.7	3.1	263
Distribution	0.65	2.3	2.3	242
Total		7.0	5.4	505

Kind	Diam	km	dB	ohm
Main	0.9	4.7	3.1	263
Distribution	0.65	2.3	2.3	242
Total		7.0	5.4	505

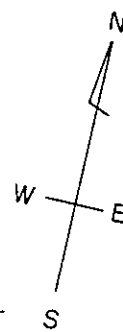

Kind	Diam	km	dB	ohm
Main	0.9	4.7	3.1	263
Distribution	0.9	3.0	2.0	168
Total		7.7	5.1	431

Kind	Diam	km	dB	ohm
Main	0.9	3.8	2.5	219
Distribution	0.4	1.0	1.8	278
	0.65	0.5	0.5	53
Total		5.3	4.8	544

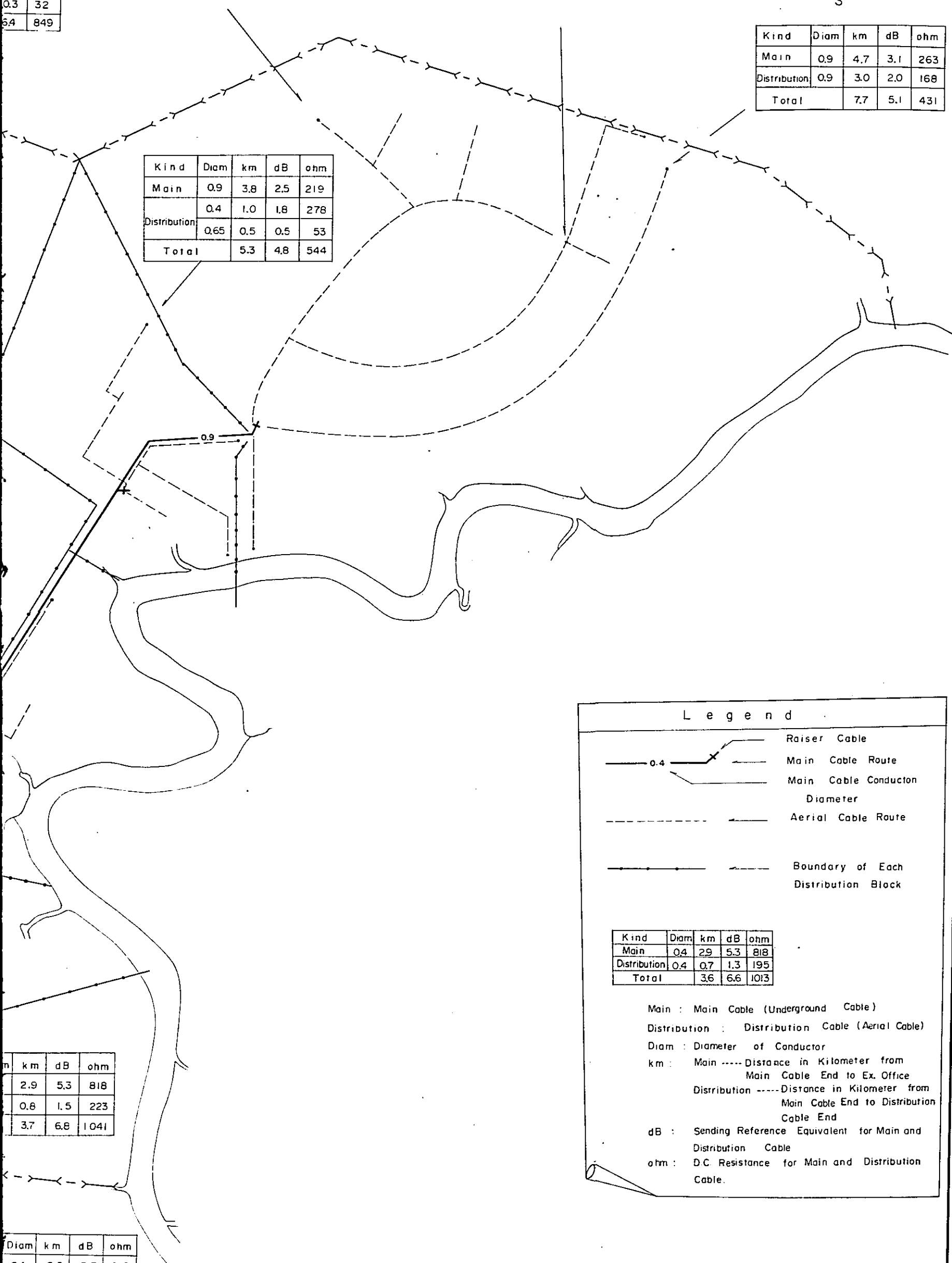

km	dB	ohm
2.9	5.3	818
0.8	1.5	223
3.7	6.8	1041

Diam	km	dB	ohm
0.4	2.9	5.3	818
0.4	0.8	1.5	223
0.5	0.6	0.8	107
0.65	0.5	0.5	53
	4.8	8.1	1201

Legend

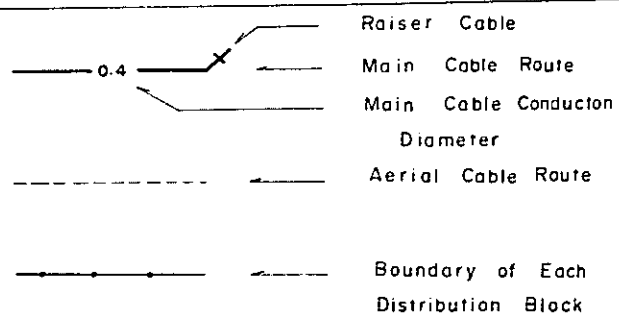

Kind	Diam	km	dB	ohm
Main	0.4	2.9	5.3	818
Distribution	0.4	0.7	1.3	195
Total		3.6	6.6	1013

Main : Main Cable (Underground Cable)

Distribution : Distribution Cable (Aerial Cable)

Diam : Diameter of Conductor

km : Main ----- Distance in Kilometer from Main Cable End to Ex. Office

Distribution ----- Distance in Kilometer from Main Cable End to Distribution Cable End

dB : Sending Reference Equivalent for Main and Distribution Cable

ohm : D.C Resistance for Main and Distribution Cable.

Exchange	Mayangon
Drawing	Key Map
Drawing No.	III . 2 . 1

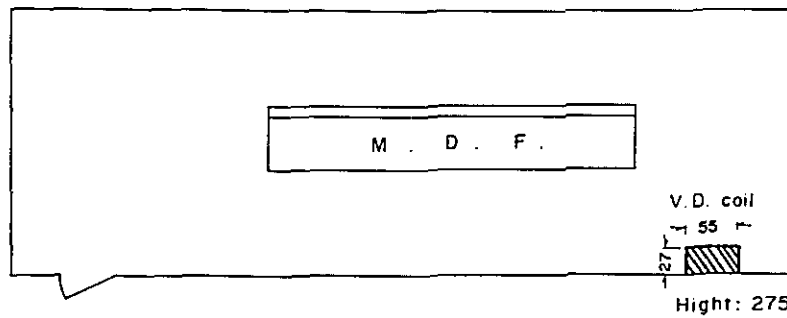

30	29	28	27	26	25	24	23	22	21	20	19	18	17	16	15	14	13	12	11	10	9	8	7	6	5	4	3	2	1
LOCAL CABLE															LOCAL CABLE														
MTL 101 ~ 200															MYG 1 ~ 400														
MTL 1 ~ 100															MYG 51 ~ 200														
															MYG 1501 ~ 300														
															MTL 151 ~ 300														
															MTL 1 ~ 150														

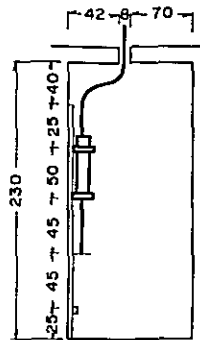

Sectional Plan of Cable Vault

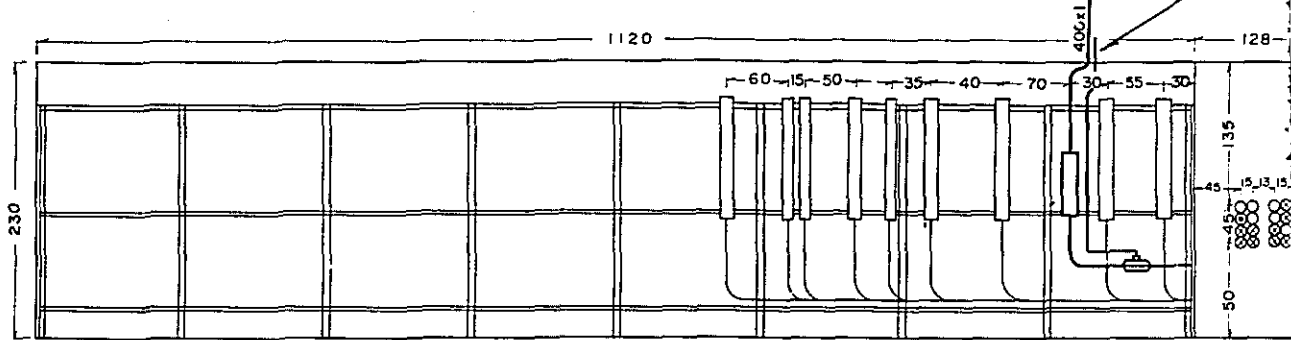

Side View

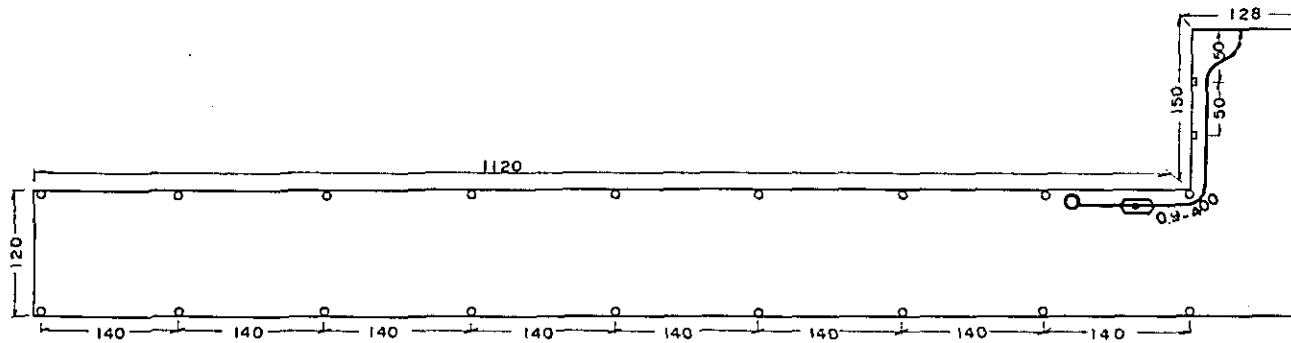

Plain Figure

Note

Scale ; 1 :
Unit ; cm

III. 3. 1. 1. Entrance Cable Diagram (Hanthawaddy Exchange Office)

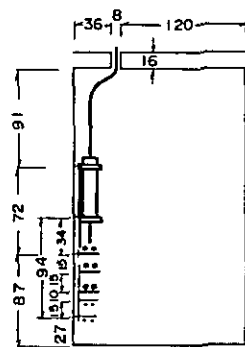

Sectional Plan of Cable Vault

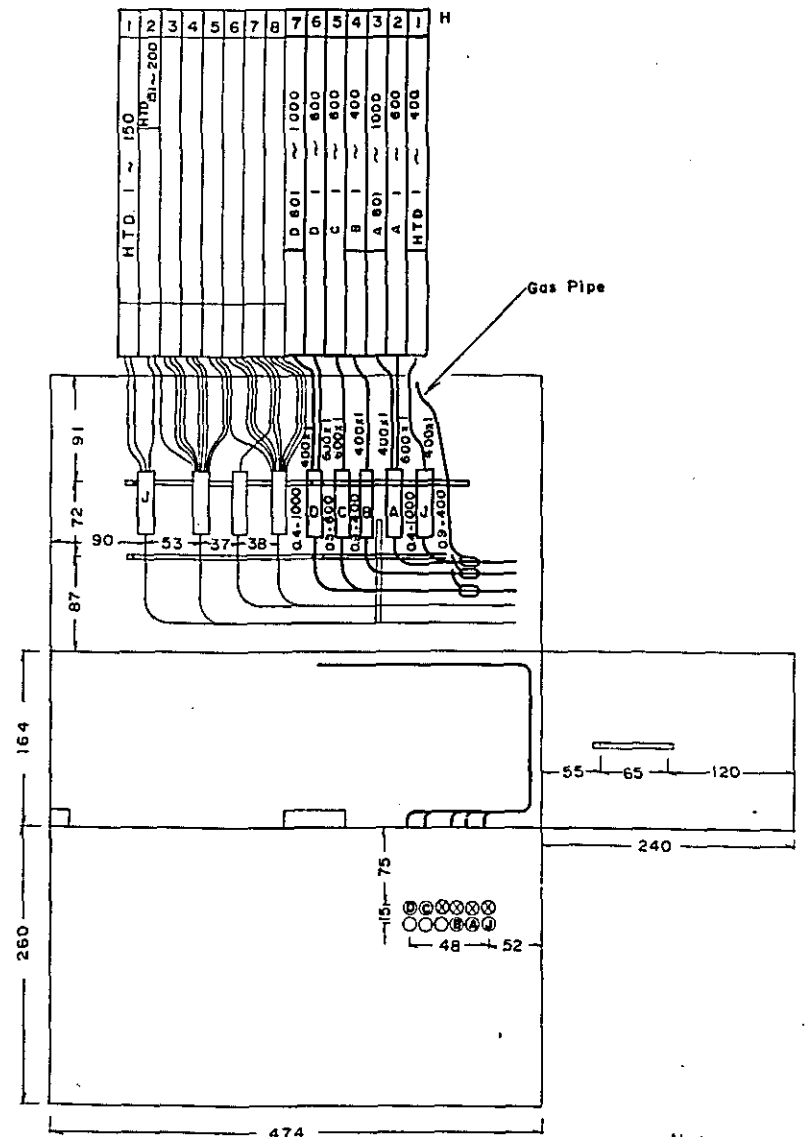

Note
Scale ; 1 : 5
Unit ; cm

III. 3. 1. 2. Entrance Cable Diagram (Mayangon Exchange Office)

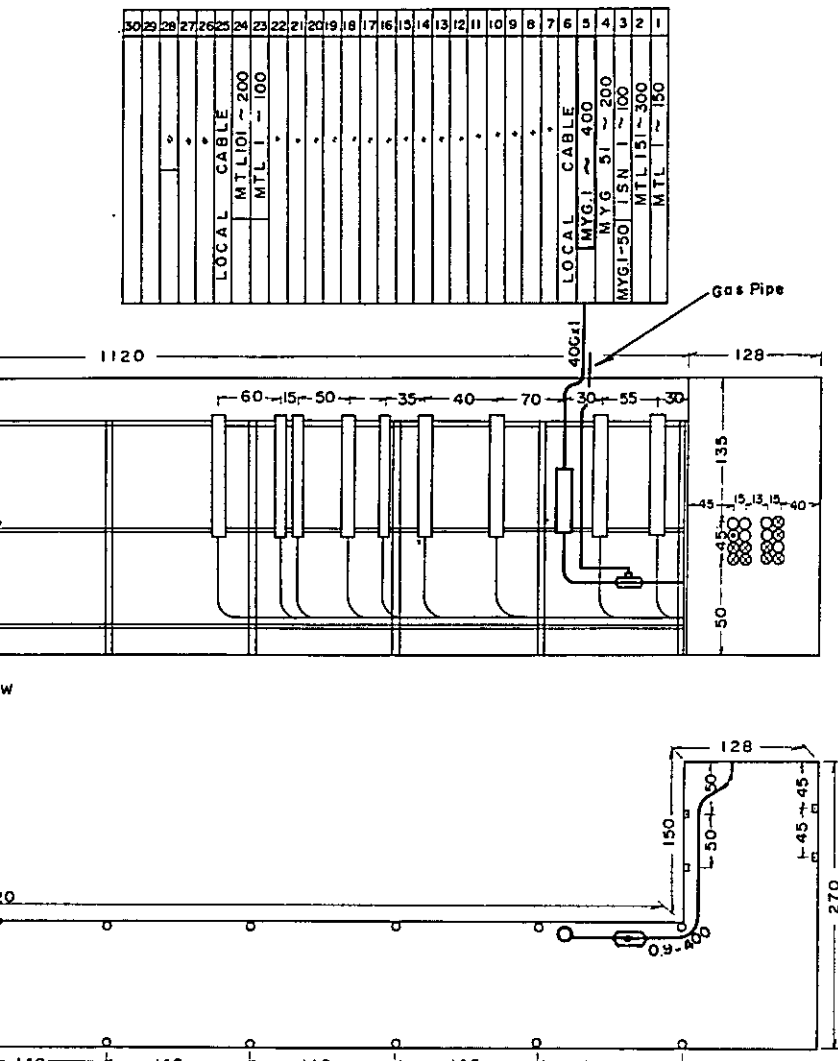

Note
Scale ; 1 : 50
Unit ; cm

Figure 1
Cable Diagram (Hanthawaddy Exchange Office.)

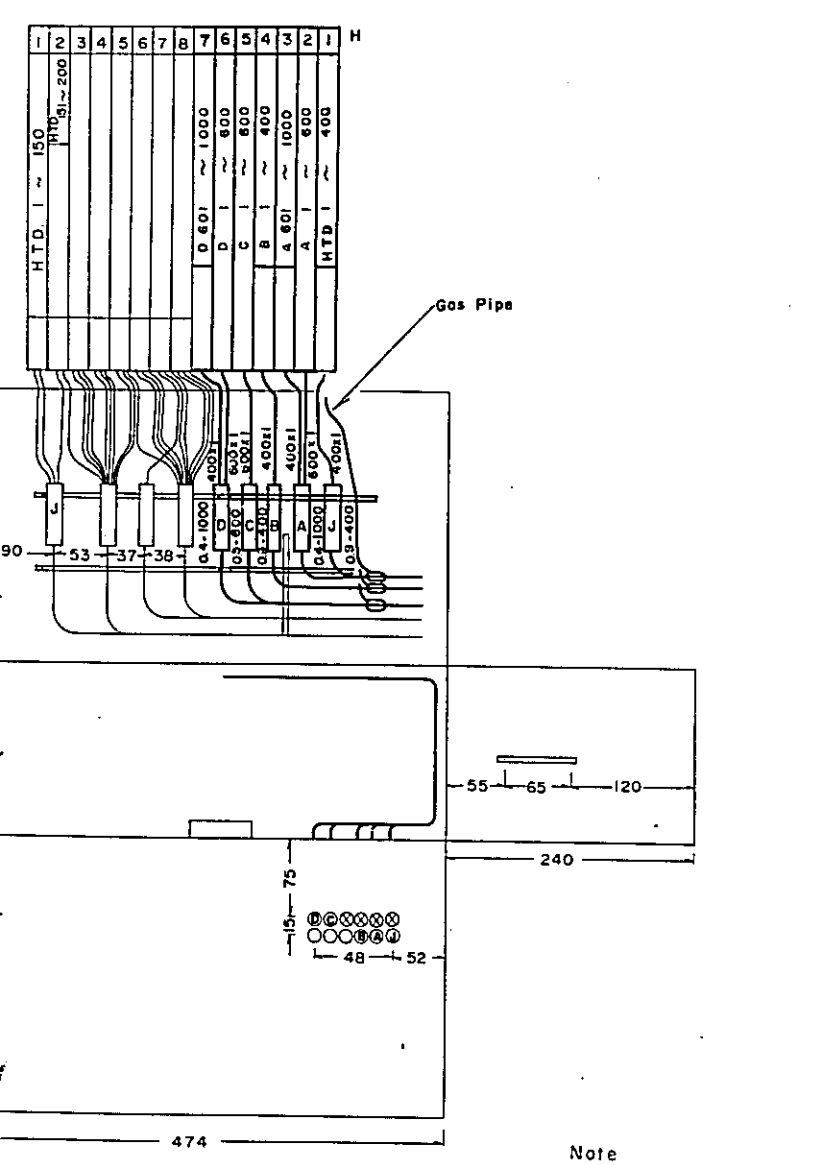

Note
Scale ; 1 : 50
Unit ; cm

Figure 2
Cable Diagram (Mayangon Exchange Office)

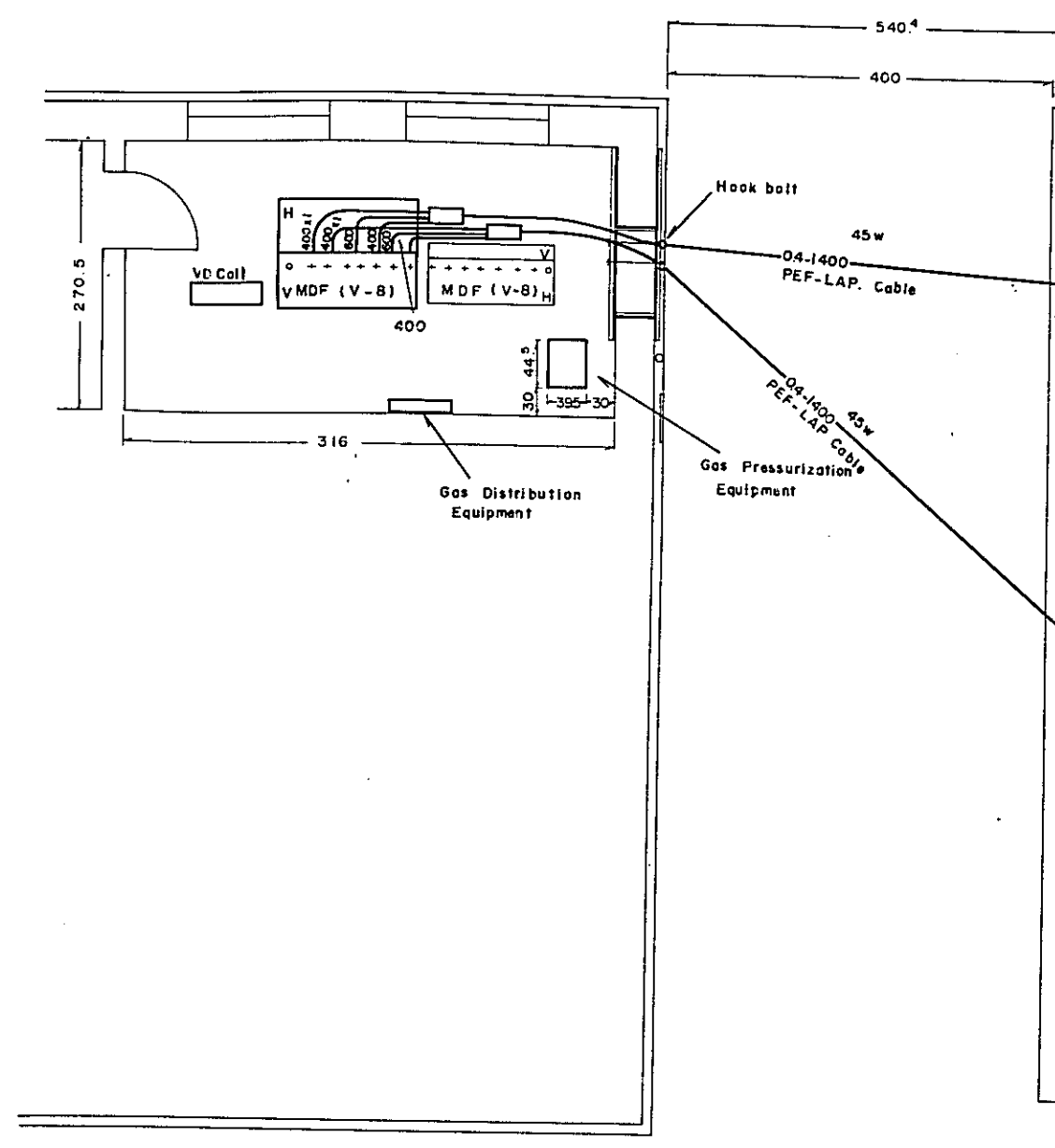

Plain Figure

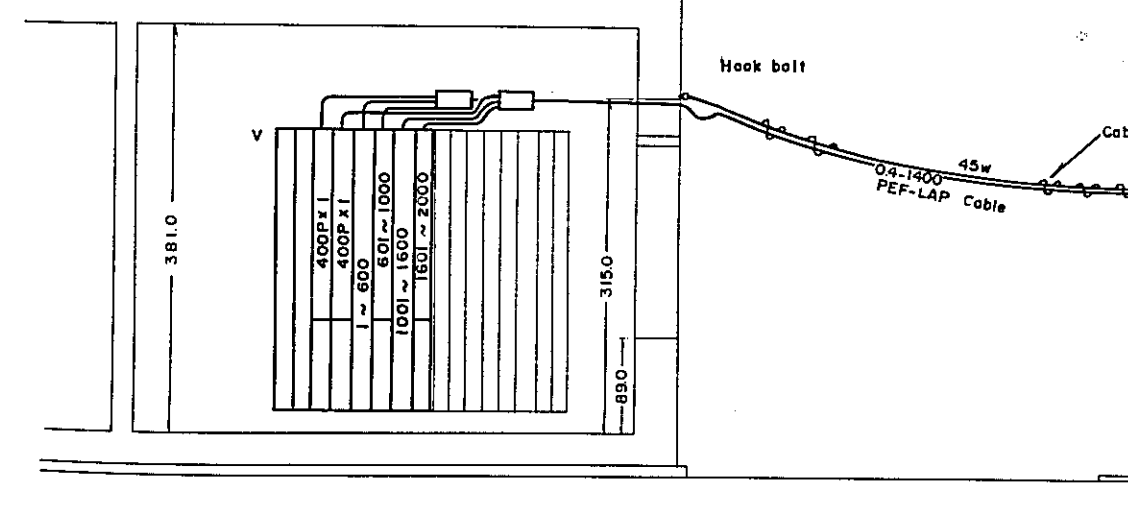

Sectional Plan

III. 3. 1. 3. C2 Type Exchange - MDF Tie

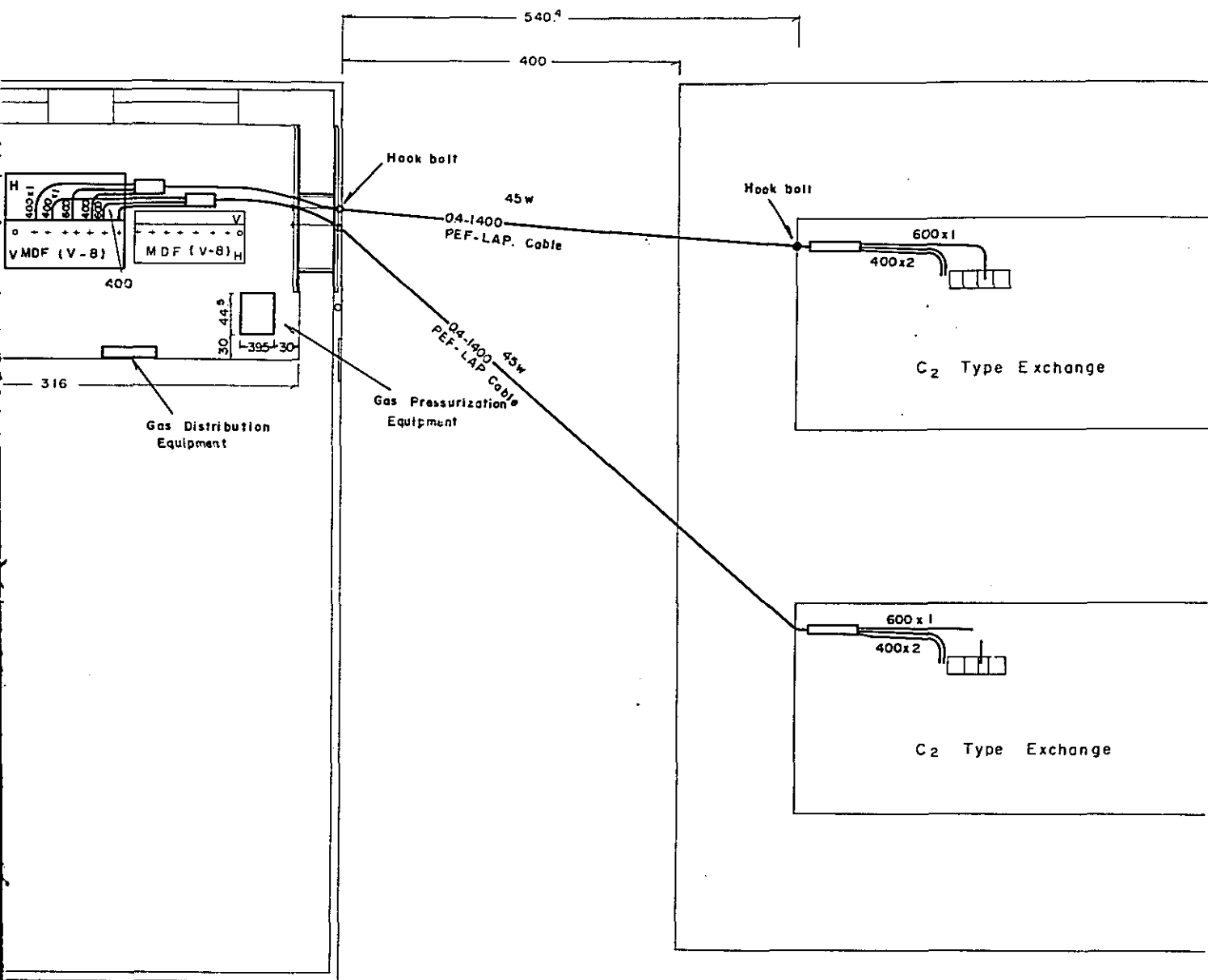

Plain Figure

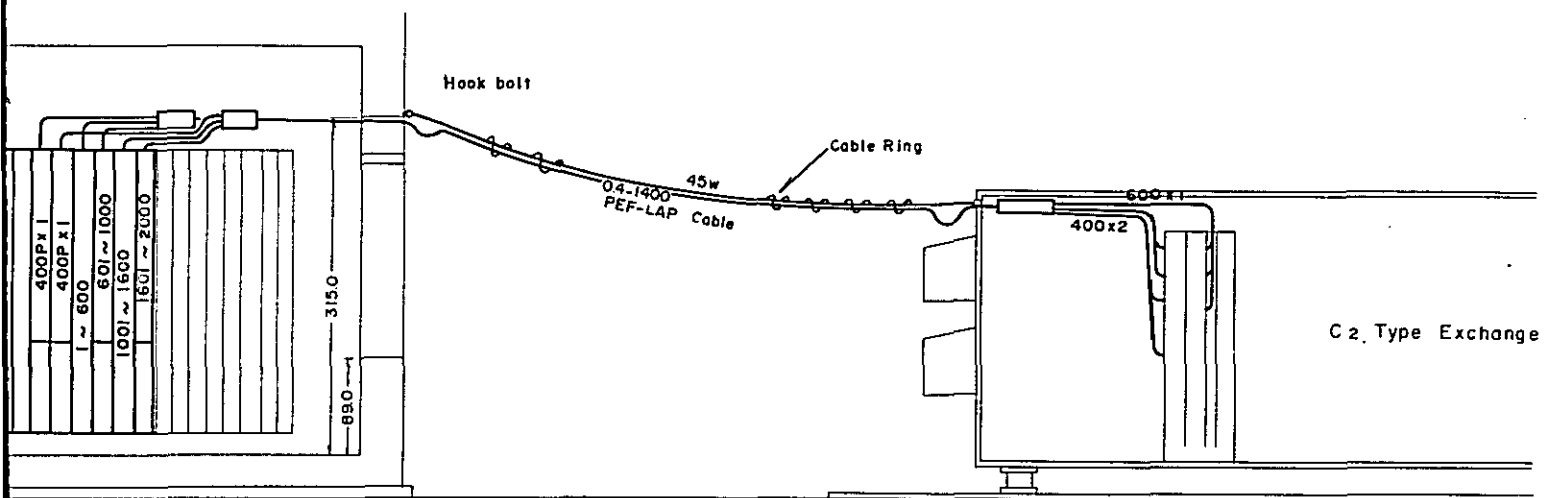

Sectional Plan

Note

Scale ; 1:50

Unit ; cm

III . 3 . 1 . 3 . C2 Type Exchange - MDF Tie Cable Diagram (Mayangon Exchange Office)

Exchange	Mayangon
Drawing	Main Distribution Frame Plan
Drawing No.	III . 3 . 1

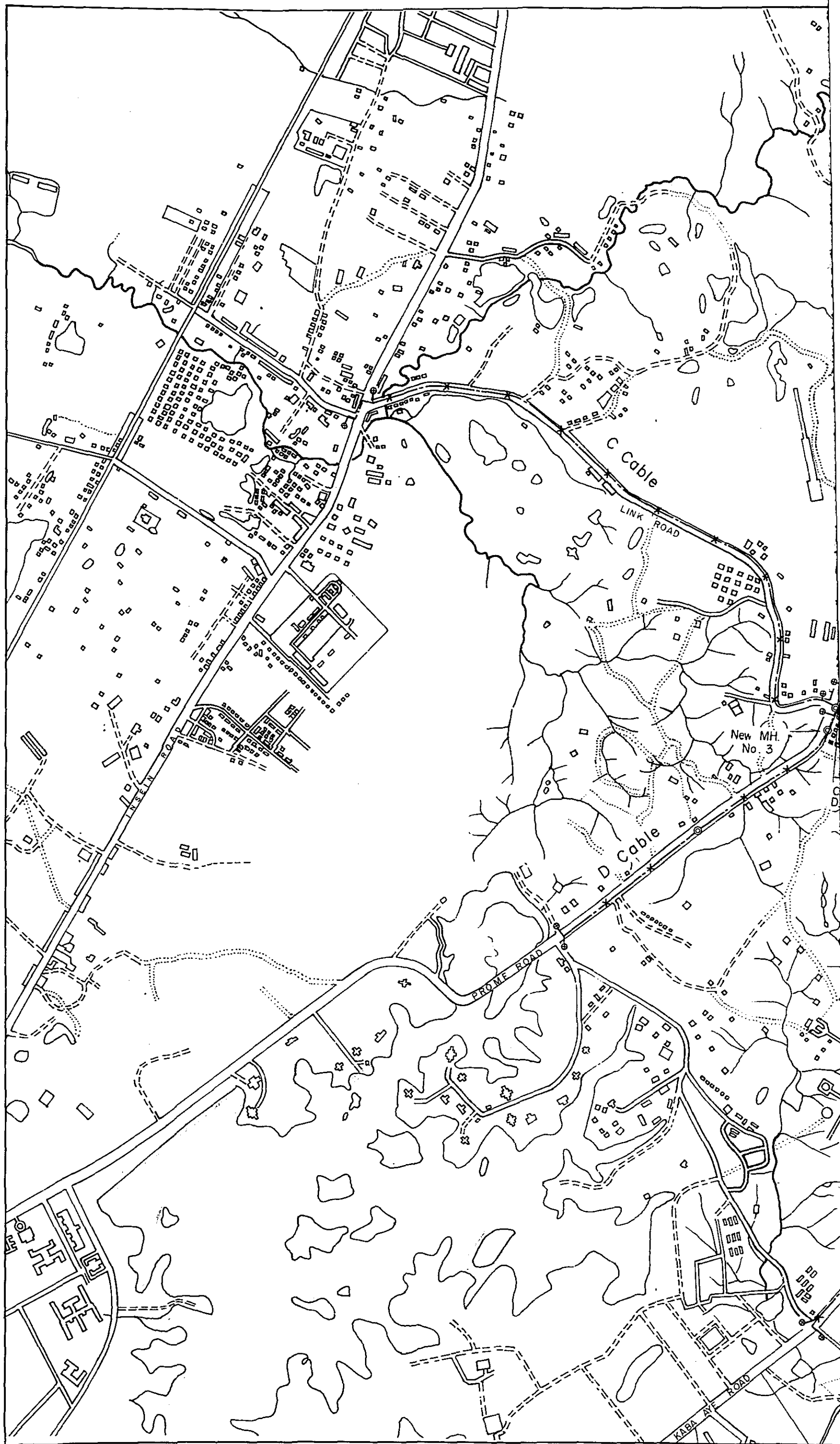

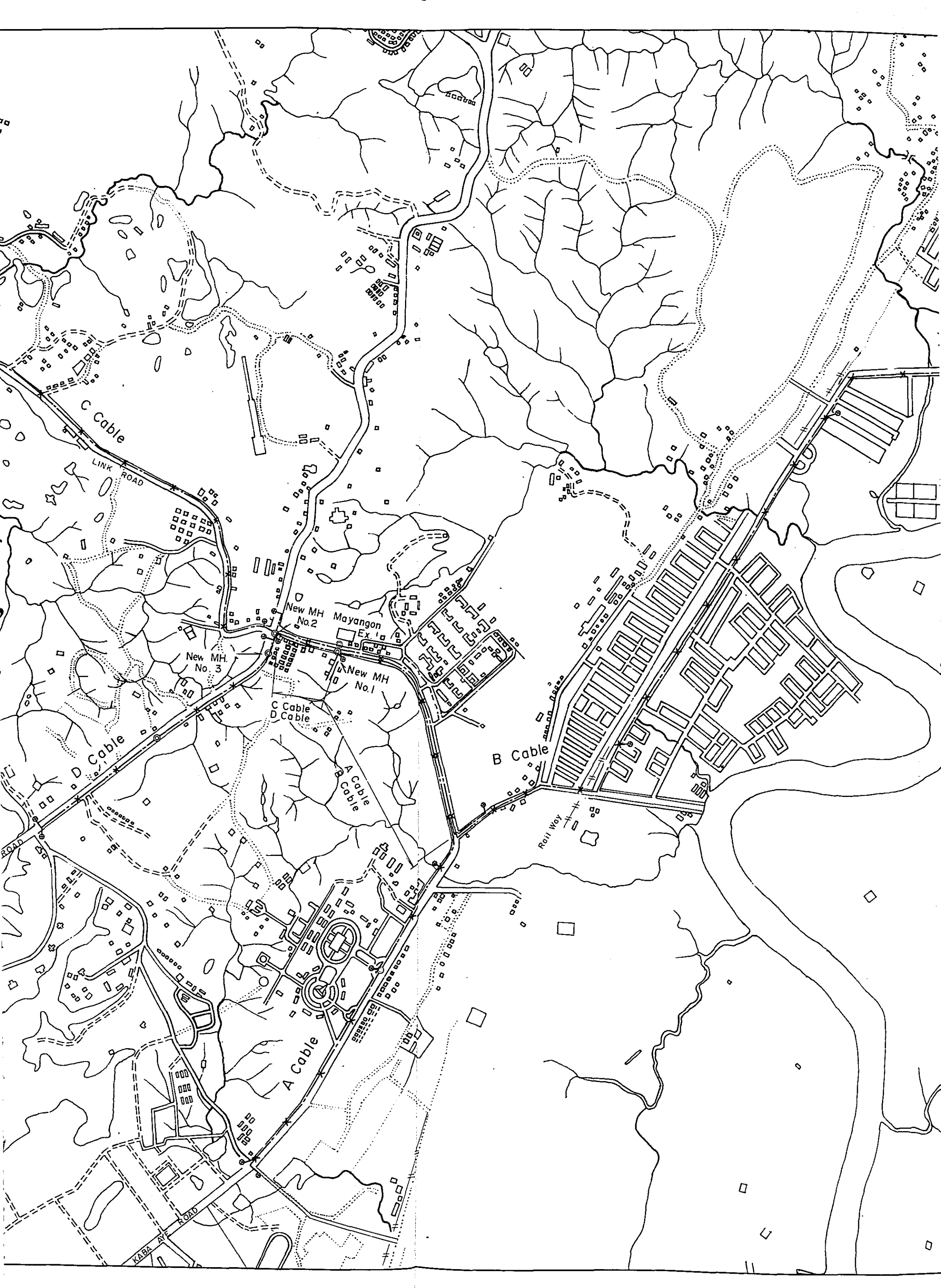

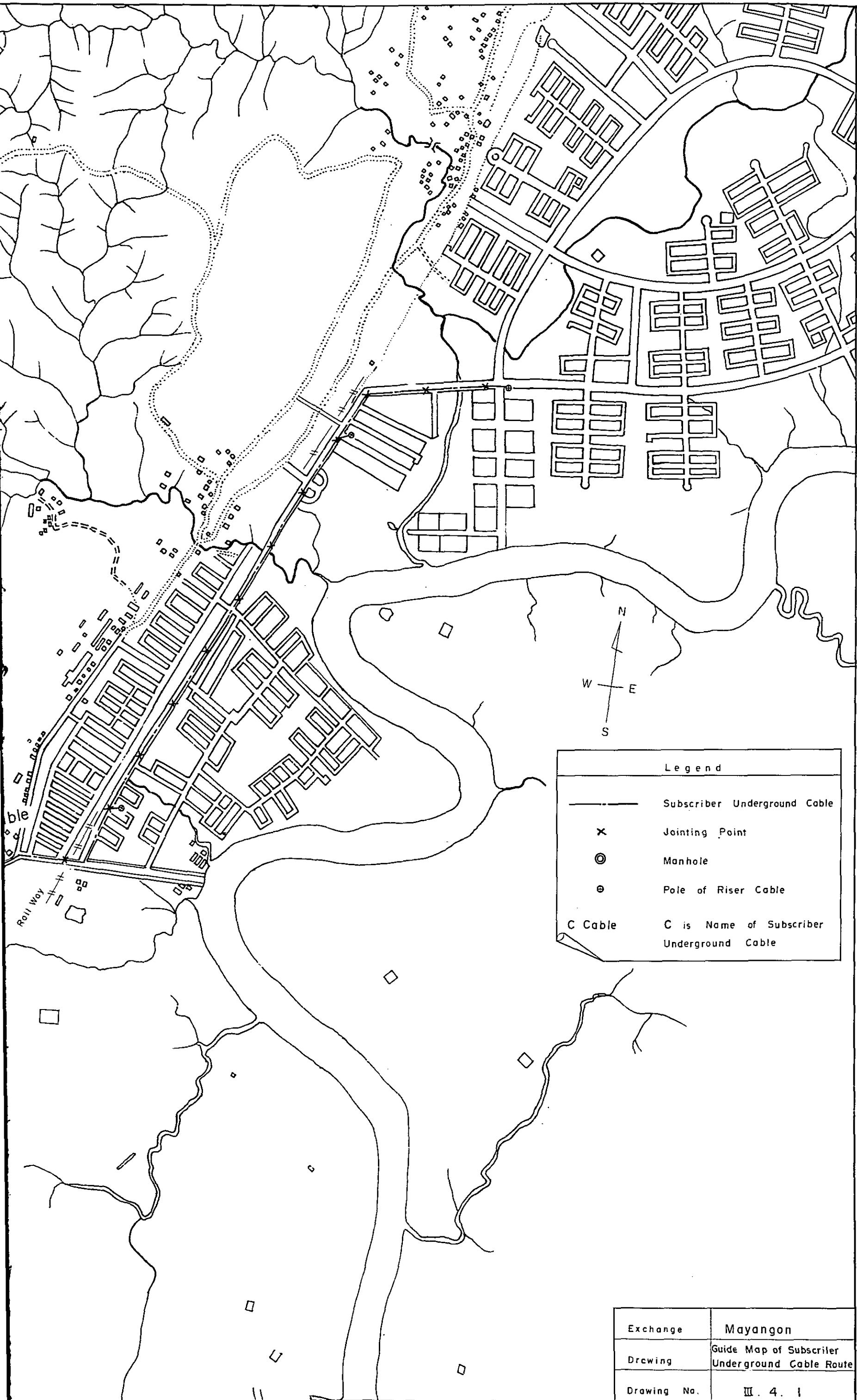

Legend	
—	Subscriber Underground Cable
X	Jointing Point
⊙	Manhole
⊕	Pole of Riser Cable
C Cable	C is Name of Subscriber Underground Cable

Exchange	Mayangon
Drawing	Guide Map of Subscriber Underground Cable Route
Drawing No.	III. 4. 1

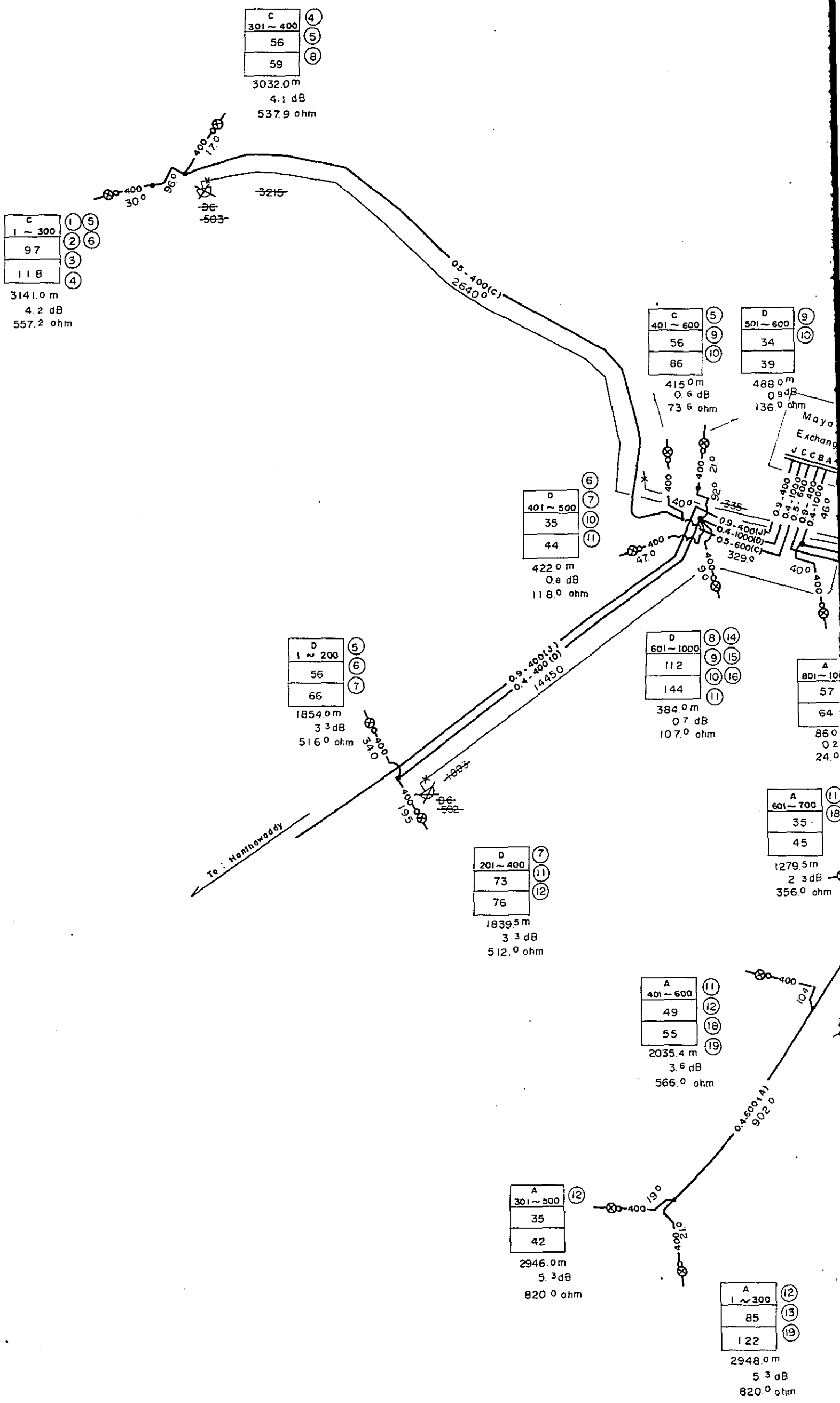

C	301 ~ 400	(4)
	56	(5)
	59	(8)
3032.0 m		
4.1 dB		
537.9 ohm		

C	1 ~ 300	(1)	(5)
	97	(2)	(6)
	118	(3)	(4)
3141.0 m			
4.2 dB			
557.2 ohm			

C	401 ~ 600	(5)
	56	(9)
	66	(10)
415.0 m		
0.6 dB		
73.6 ohm		

D	501 ~ 600	(9)	(10)
	34		
	39		
488.0 m			
0.9 dB			
136.0 ohm			

D	401 ~ 500	(6)	(7)	(10)	(11)
	35				
	44				
422.0 m					
0.8 dB					
118.0 ohm					

D	1 ~ 200	(5)	(6)	(7)
	56			
	66			
1854.0 m				
3.3 dB				
516.0 ohm				

D	601 ~ 1000	(8)	(14)
	112	(9)	(15)
	144	(10)	(16)
384.0 m			
0.7 dB			
107.0 ohm			

A	801 ~ 1000	(11)	(18)
	57		
	64		
86.0 m			
0.2 dB			
24.0 ohm			

A	601 ~ 700	(11)	(18)
	35		
	45		
1279.5 m			
2.3 dB			
356.0 ohm			

D	201 ~ 400	(7)	(11)	(12)
	73			
	76			
1839.5 m				
3.3 dB				
512.0 ohm				

A	401 ~ 600	(11)	(12)	(18)	(19)
	49				
	55				
2035.4 m					
3.6 dB					
566.0 ohm					

A	301 ~ 500	(12)
	35	
	42	
2946.0 m		
5.3 dB		
820.0 ohm		

A	1 ~ 300	(12)	(13)	(19)
	85			
	122			
2948.0 m				
5.3 dB				
820.0 ohm				

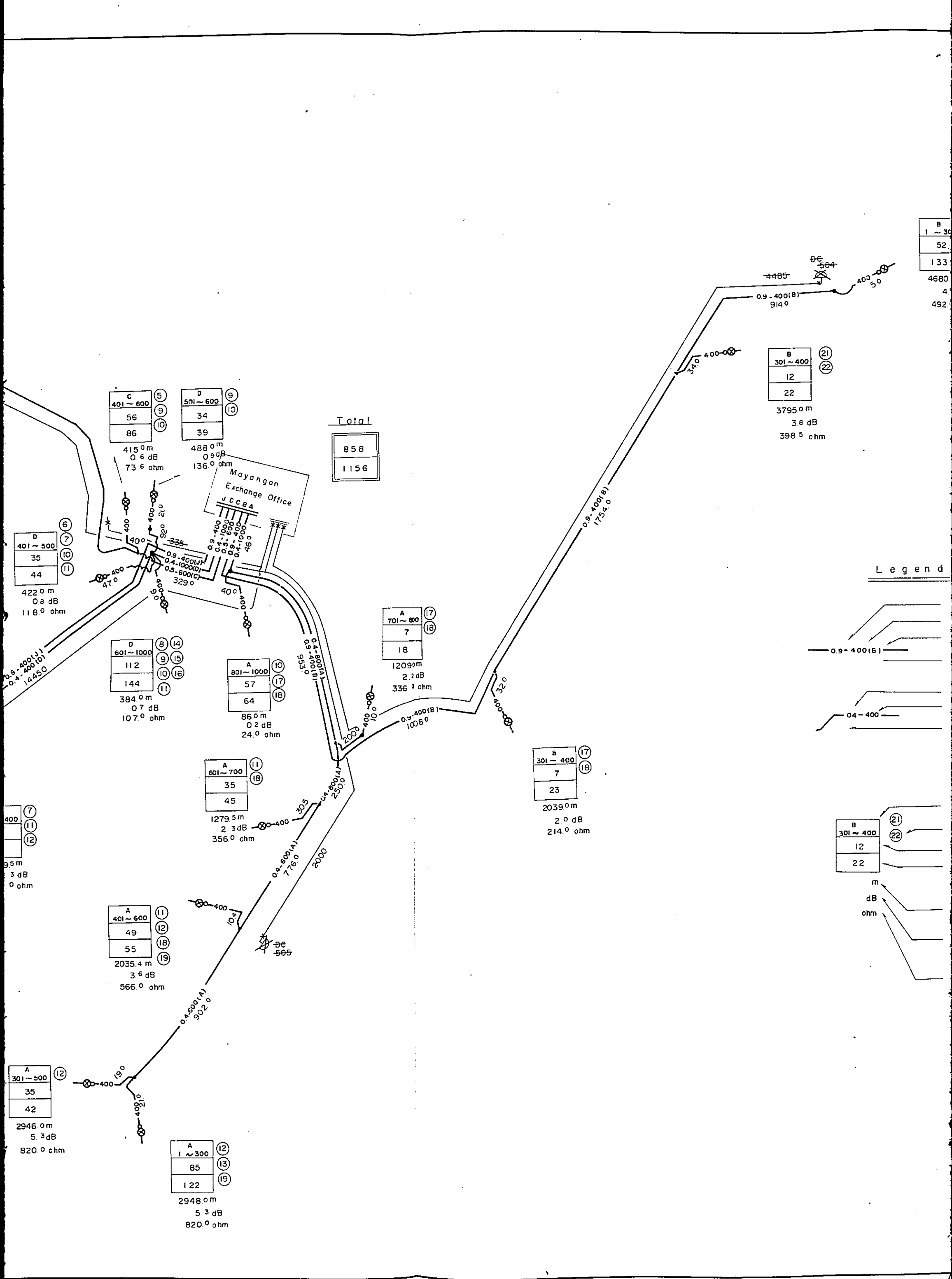

B
1 ~ 30
52
133
4680
4
492

Total

858
1156

B
301 ~ 400
12
22
3795.0 m
3.8 dB
398.5 ohm

Legend

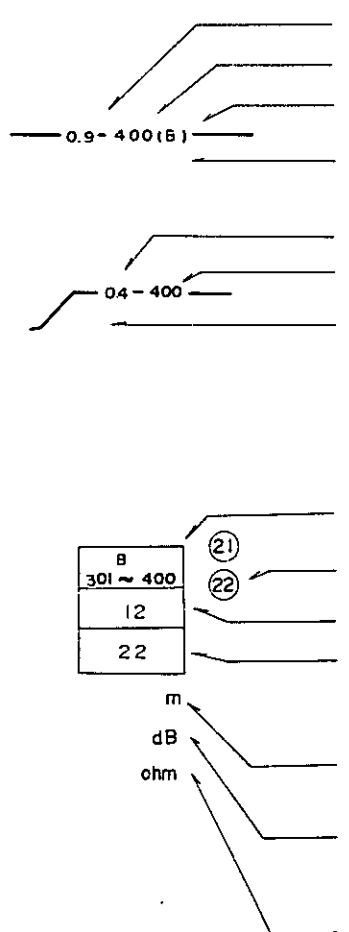

C
401 ~ 600
56
86
415.0 m
0.6 dB
73.6 ohm

D
501 ~ 600
34
39
488.0 m
0.9 dB
136.0 ohm

D
401 ~ 500
35
44
422.0 m
0.8 dB
118.0 ohm

D
601 ~ 1000
112
144
384.0 m
0.7 dB
107.0 ohm

A
801 ~ 1000
57
64
86.0 m
0.2 dB
24.0 ohm

A
701 ~ 800
7
18
1209.0 m
2.2 dB
336.0 ohm

B
301 ~ 400
7
23
2039.0 m
2.0 dB
214.0 ohm

A
601 ~ 700
35
45
1279.5 m
2.3 dB
356.0 ohm

7
11
12
9.5 m
3 dB
0 ohm

A
401 ~ 600
49
55
2035.4 m
3.6 dB
566.0 ohm

A
301 ~ 500
35
42
2946.0 m
5.3 dB
820.0 ohm

A
1 ~ 300
85
122
2948.0 m
5.3 dB
820.0 ohm

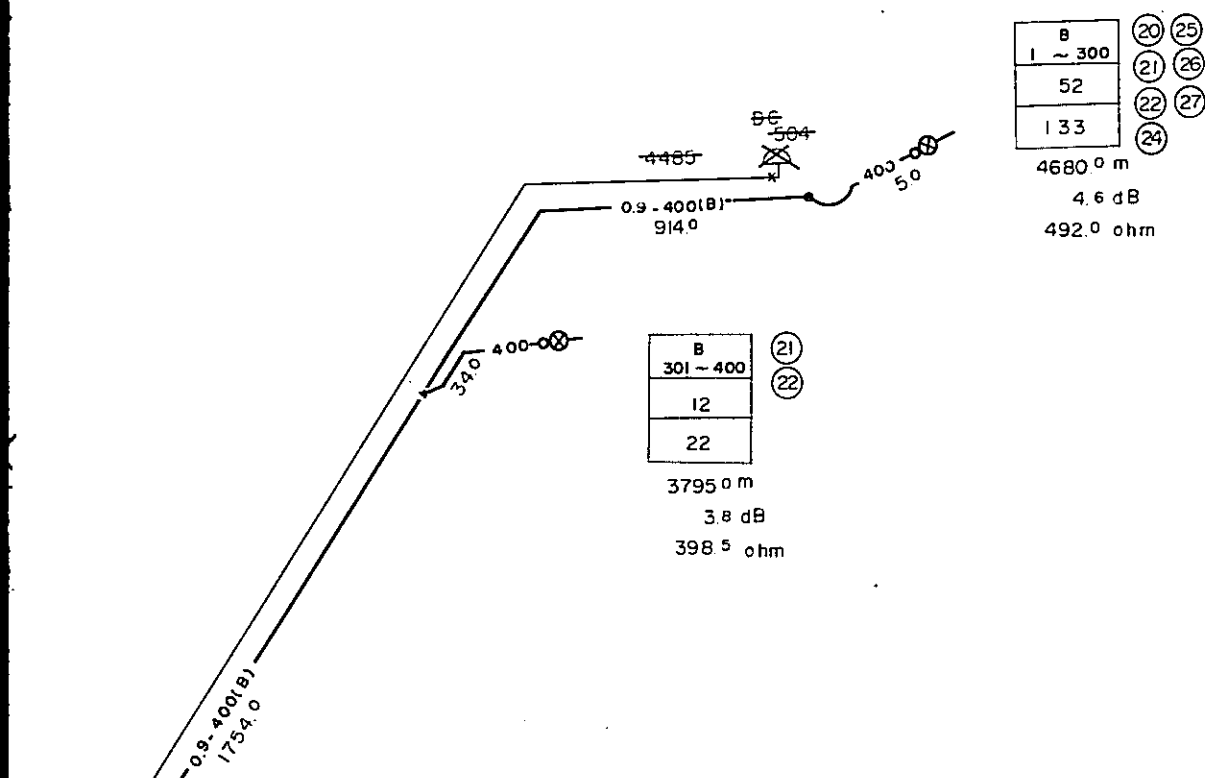

B	(17)
301 ~ 400	(18)
7	
23	

2039.0 m
2.0 dB
214.0 ohm

Legend

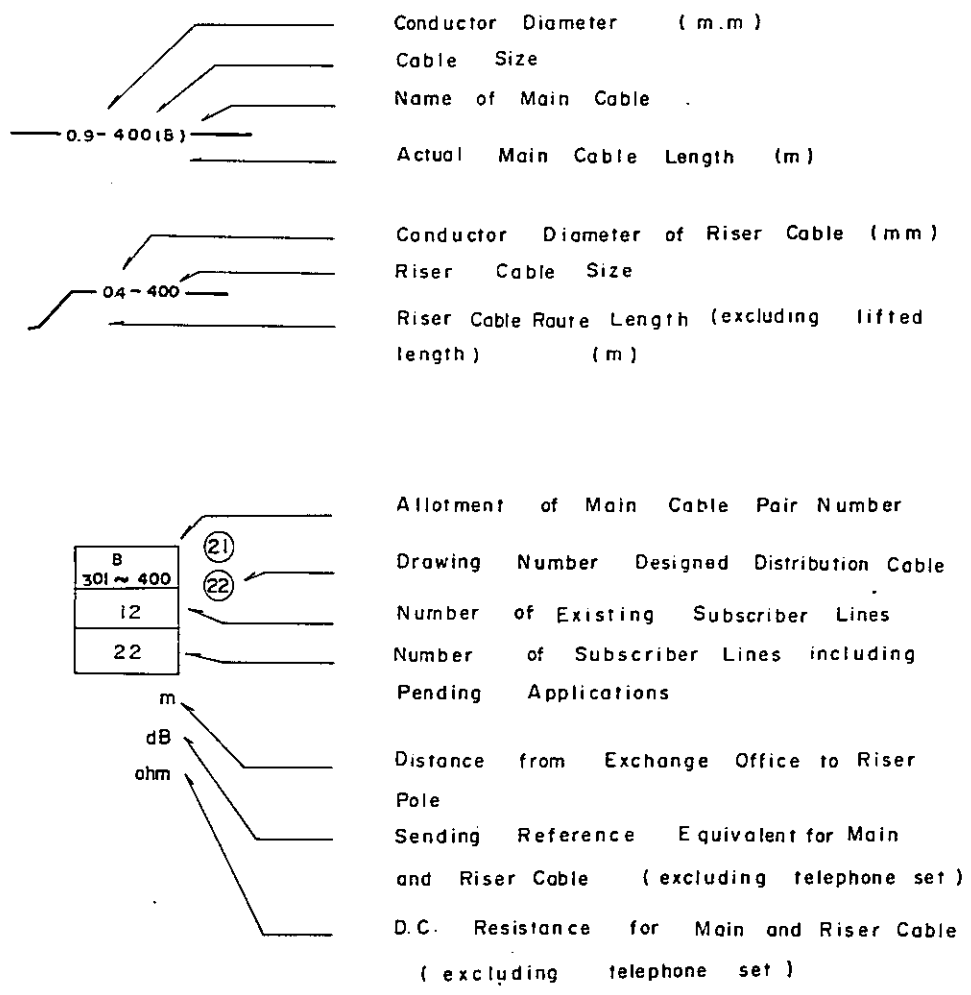

Exchange	Mayangon
Drawing	Subscriber Underground Cable Plan
Drawing No.	III . 5 . 1

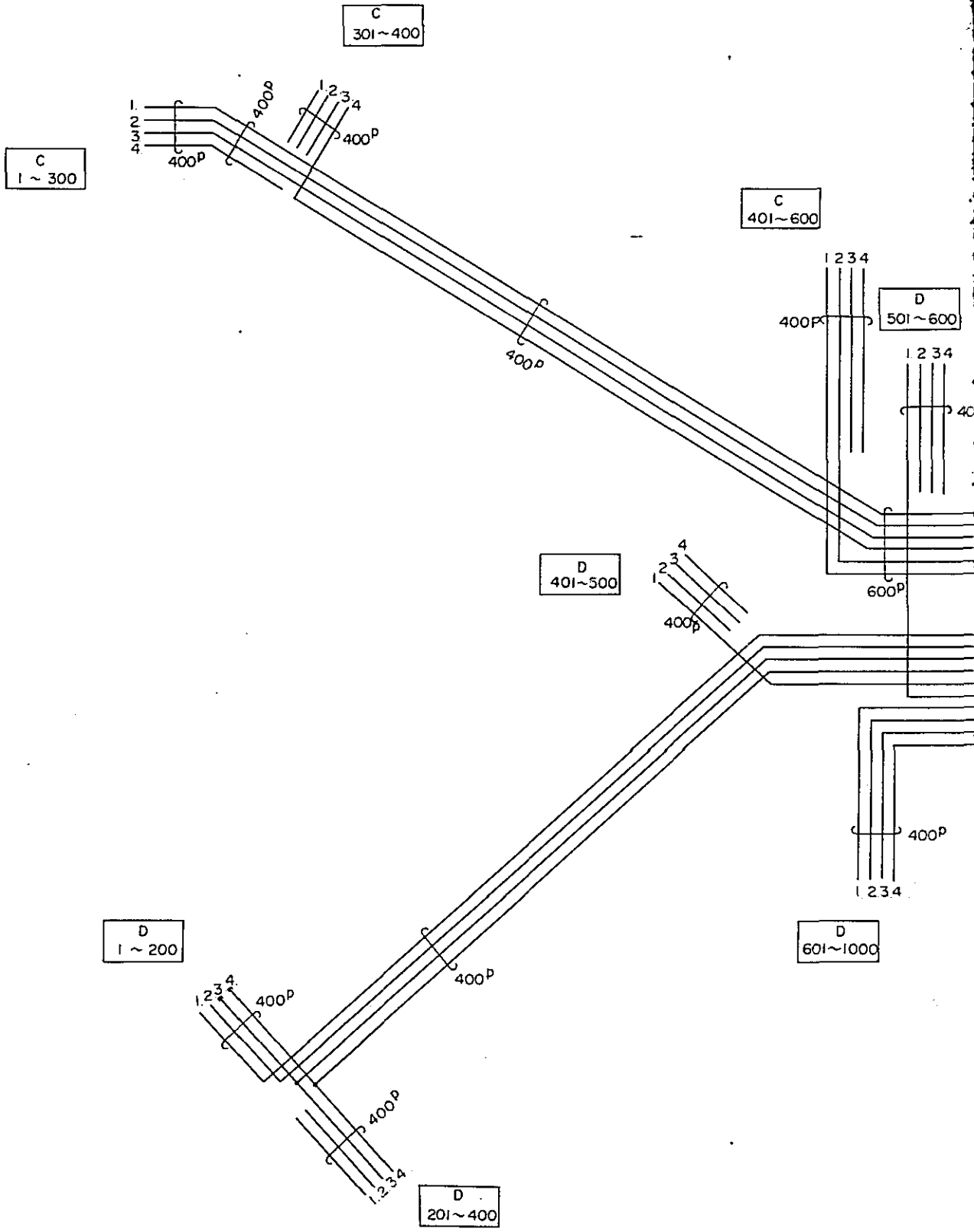

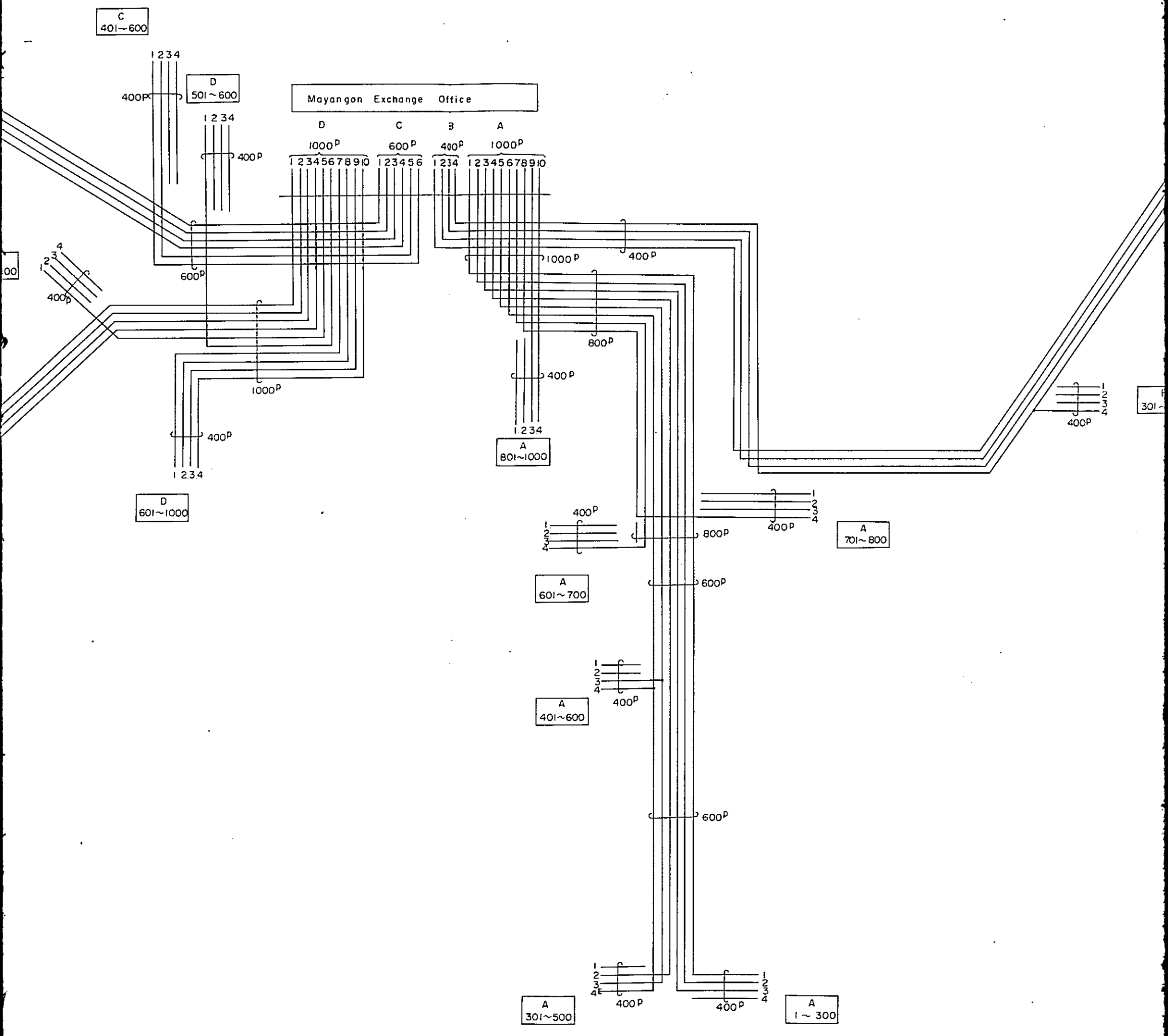

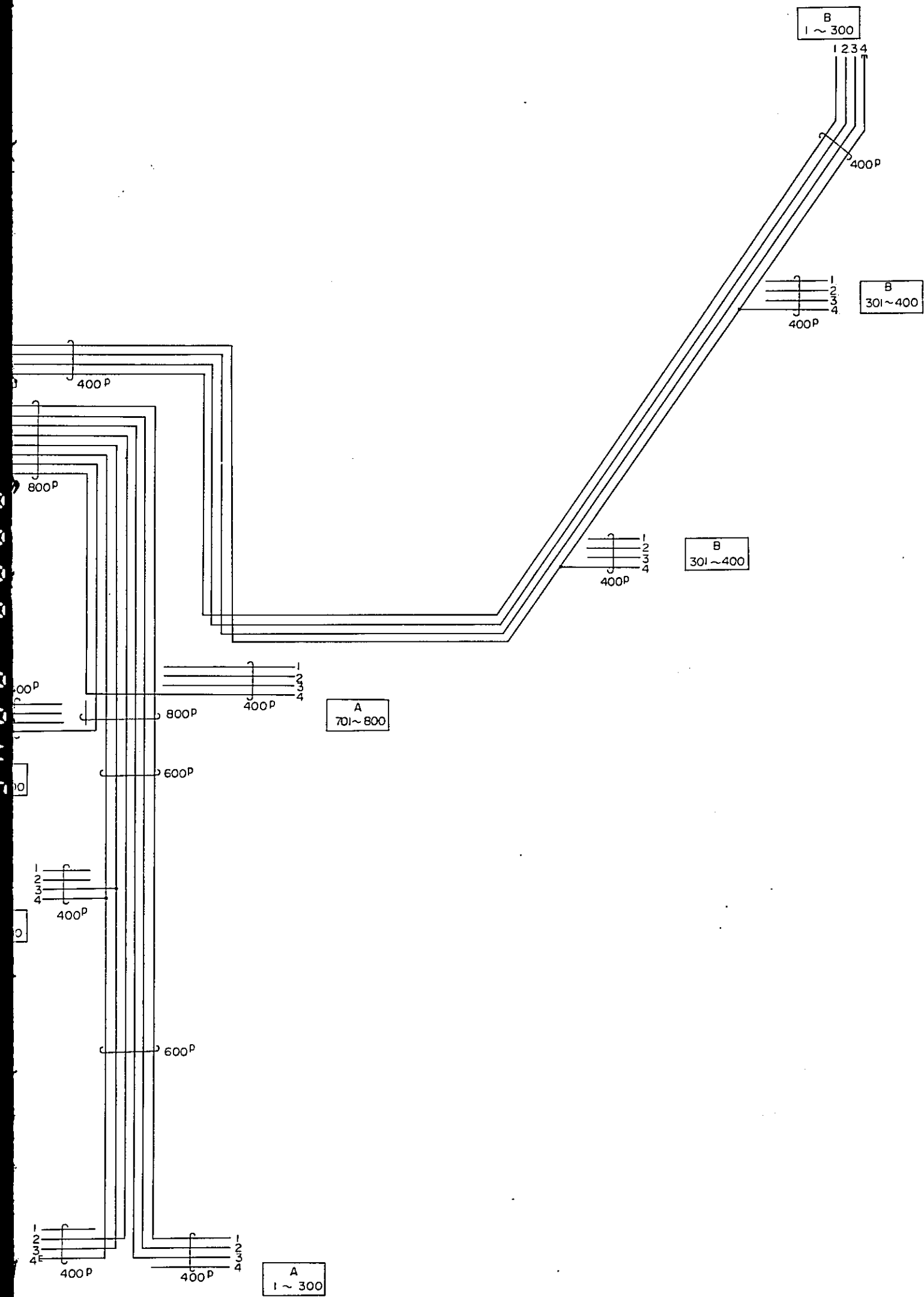

Exchange	Mayangon
Drawing	Allotment Plan of Subscriber Underground Cable Unit Number
Drawing No.	III. 6. 1

A cable

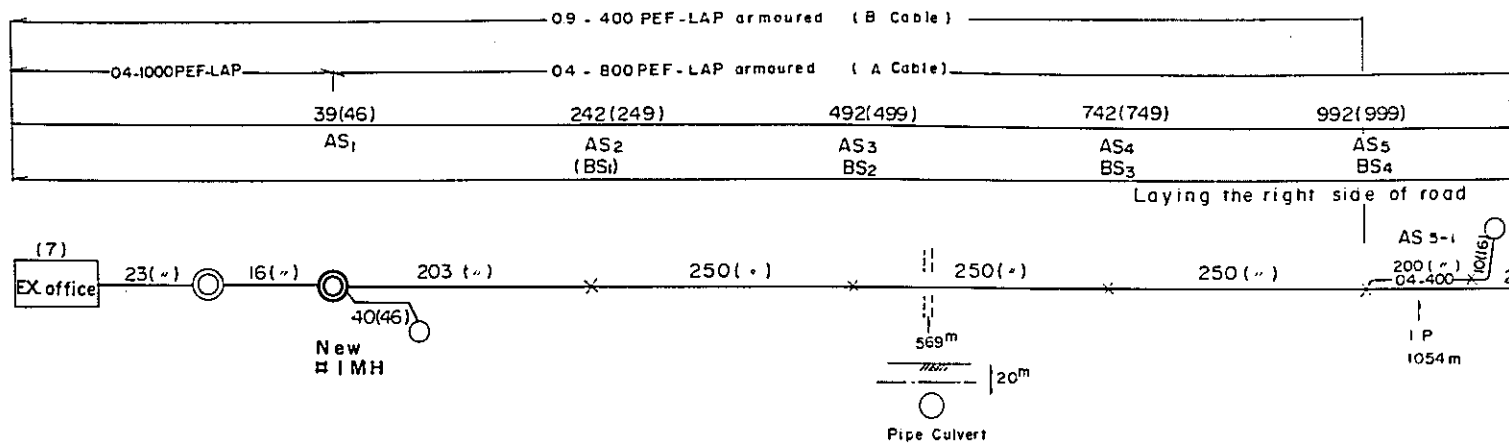

B cable

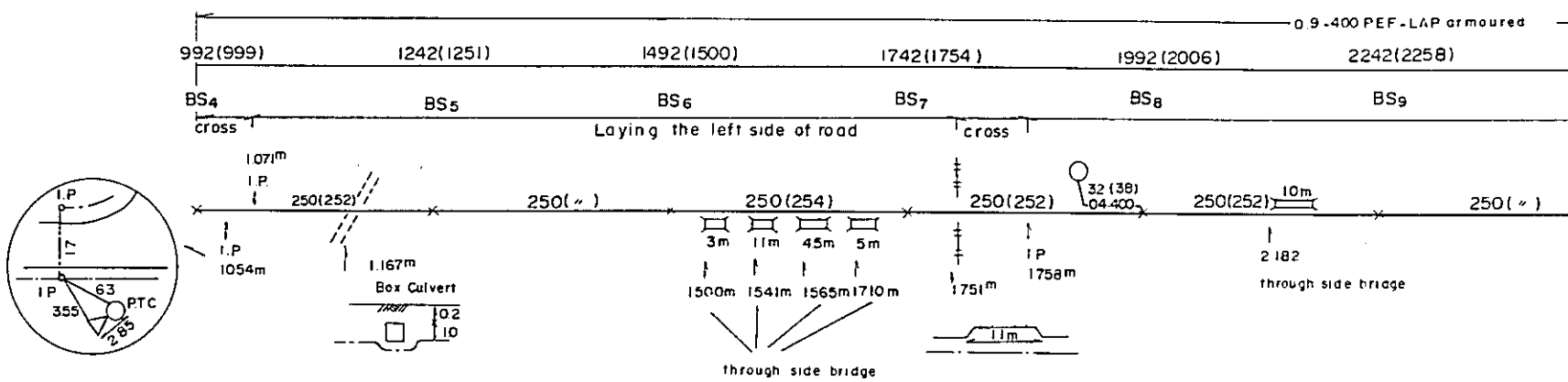

C cable

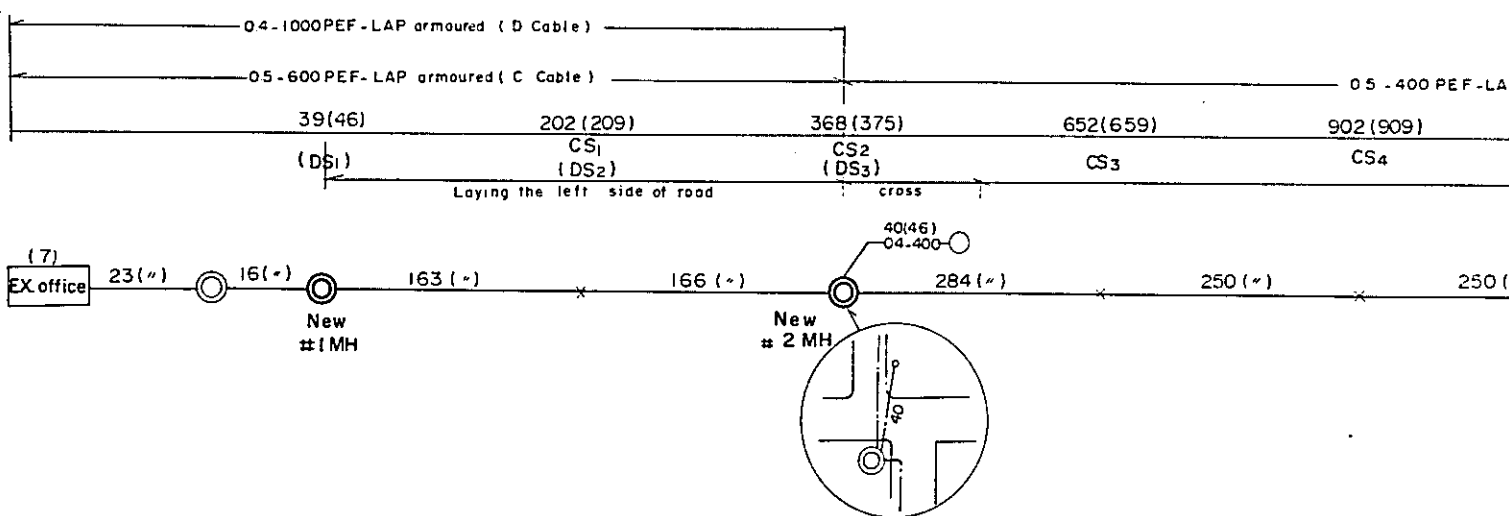

D cable

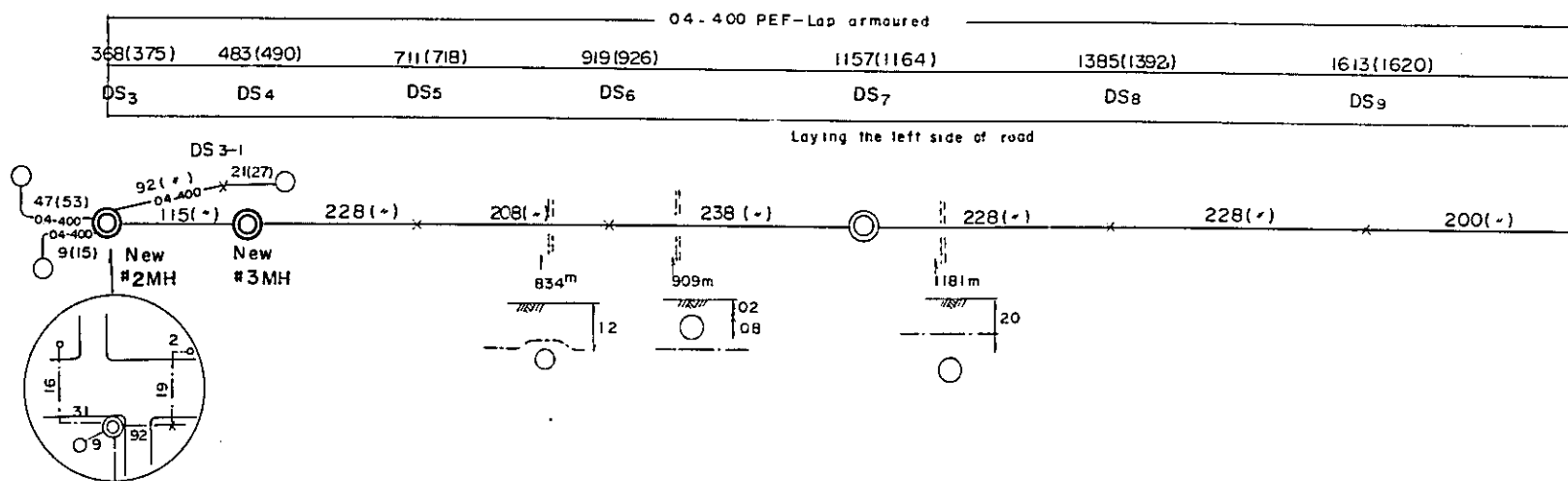

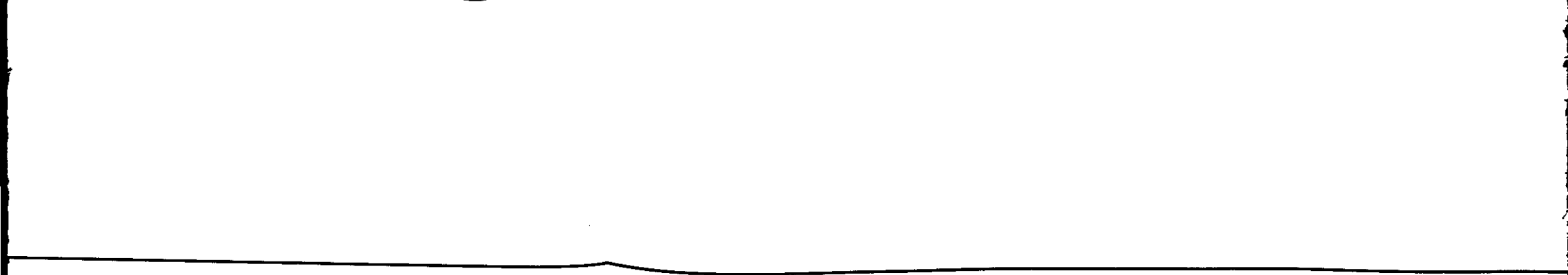
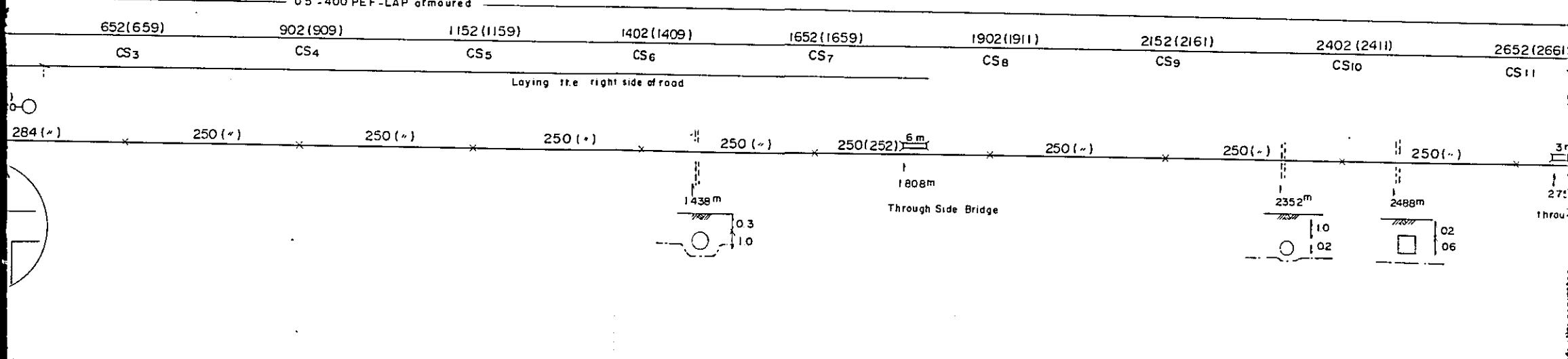
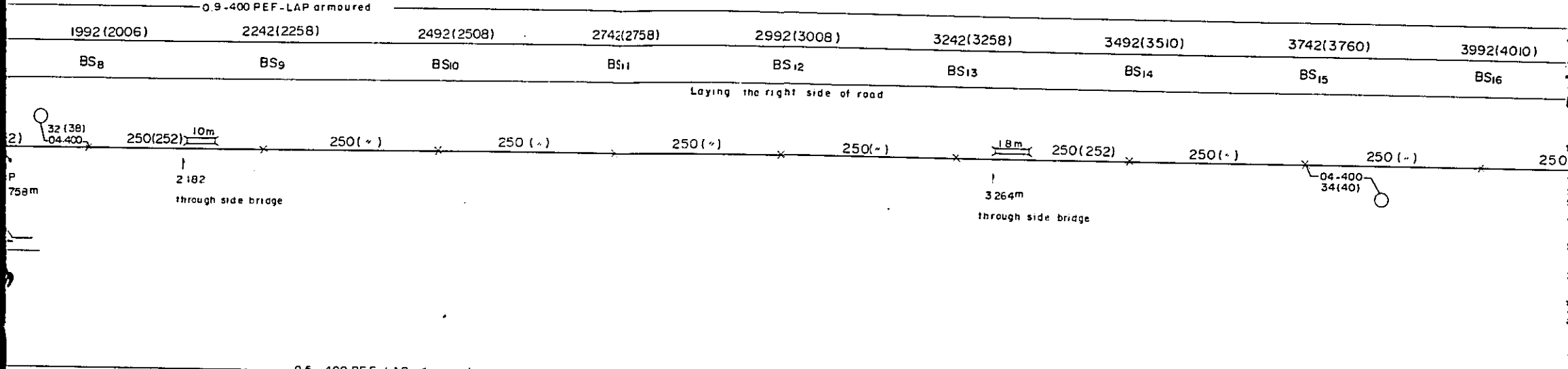
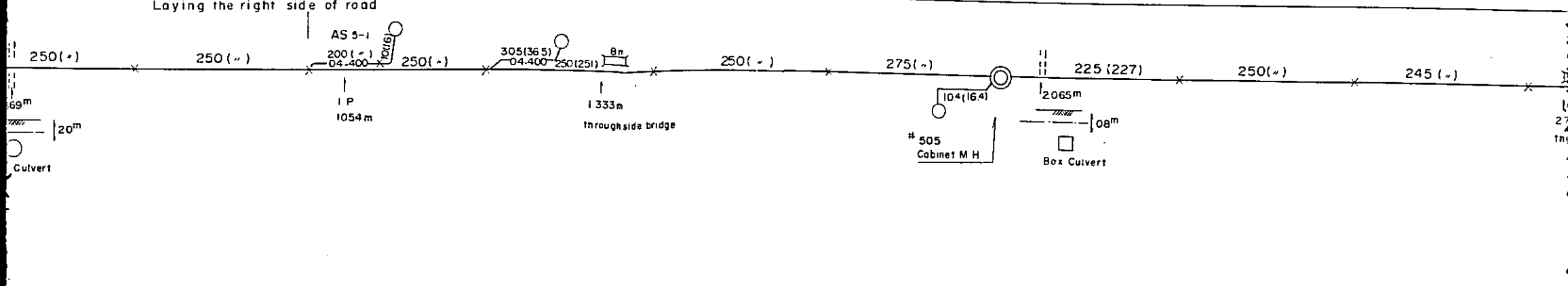
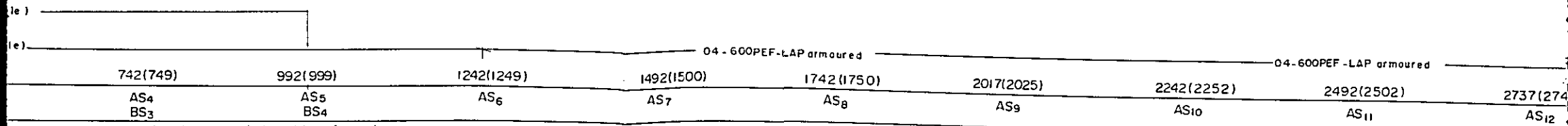

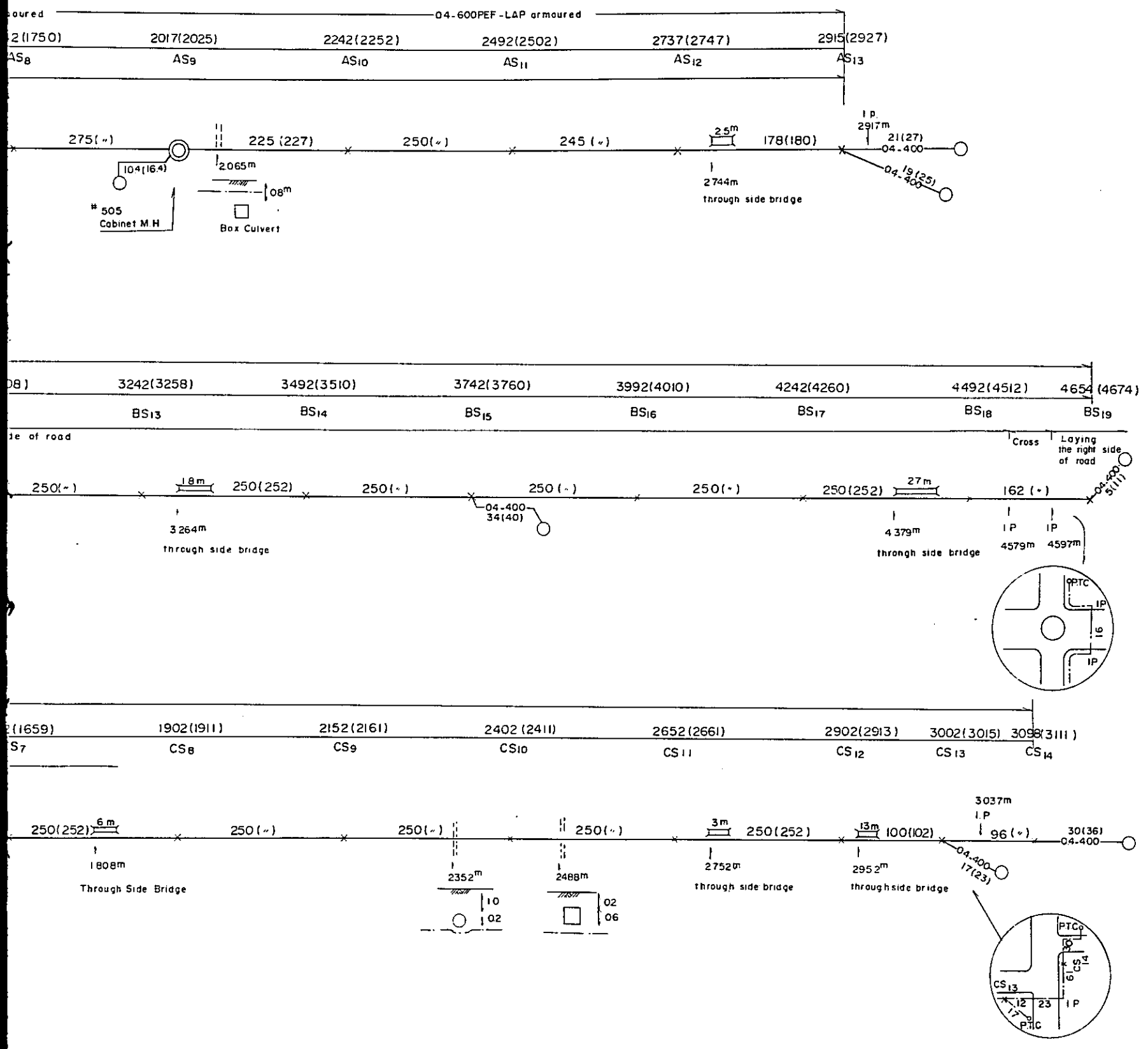

Exchange	Mayangon
Drawing	Diagram of Subscriber Underground Cable
Drawing No.	III . 7 . I

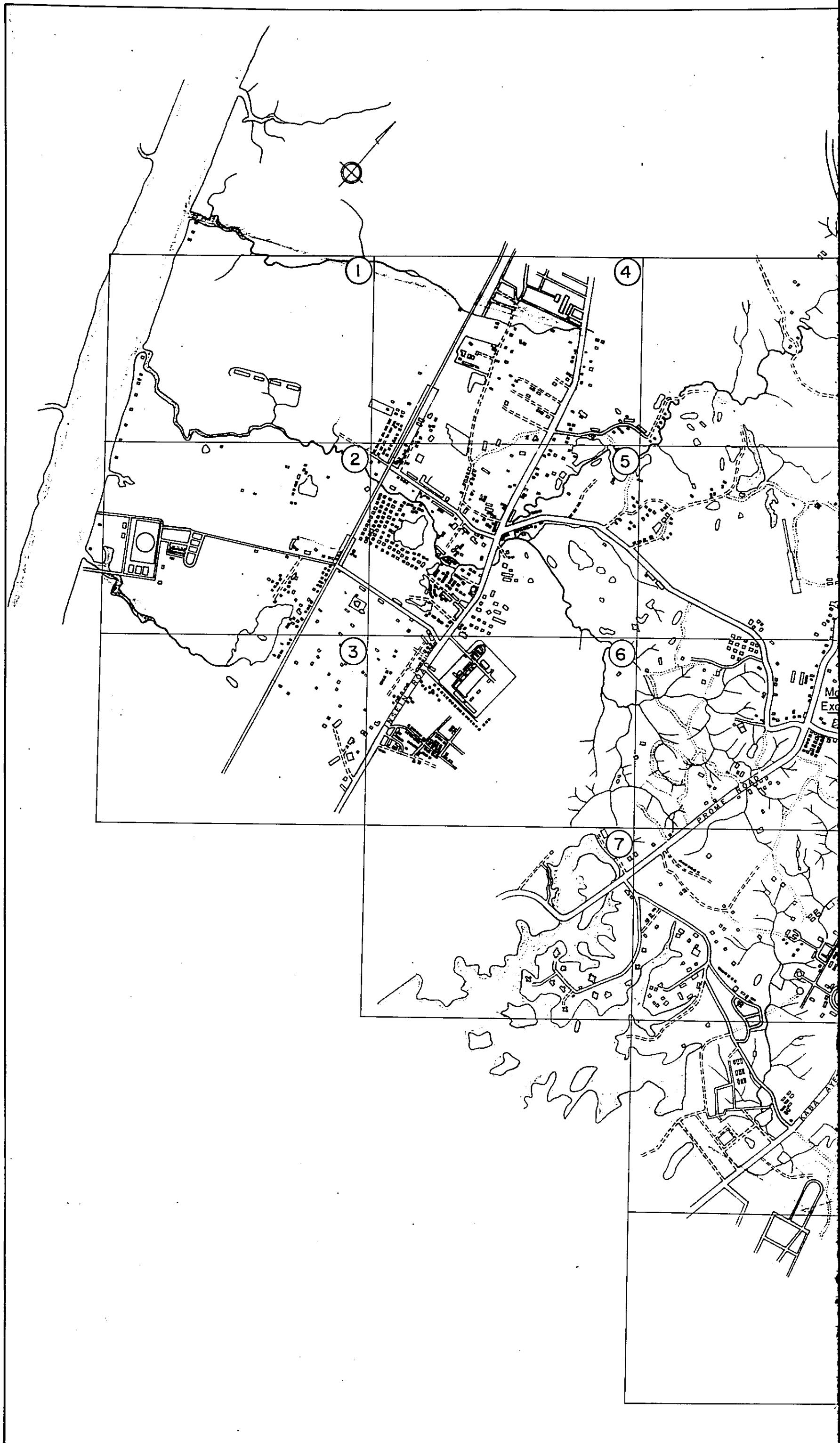

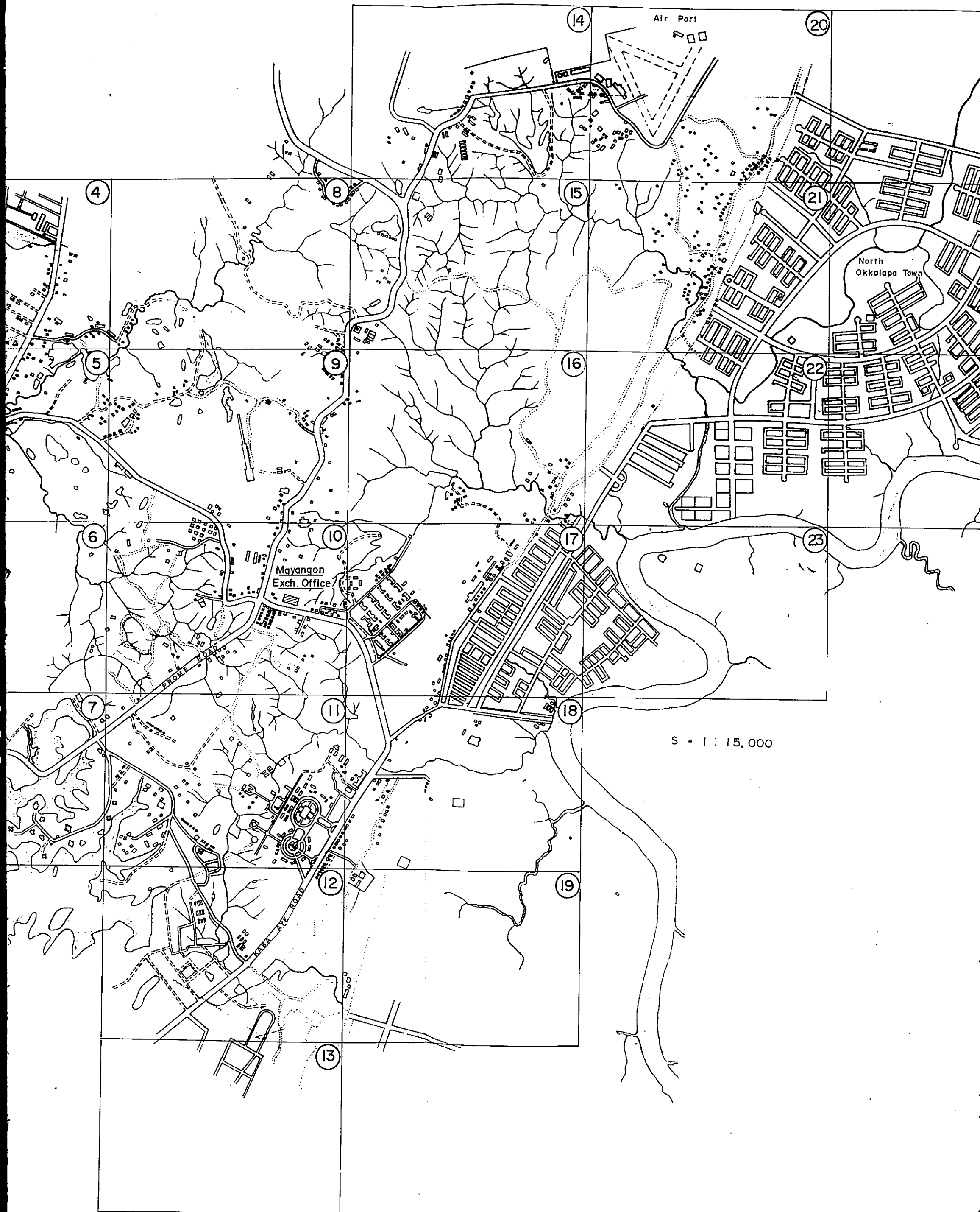

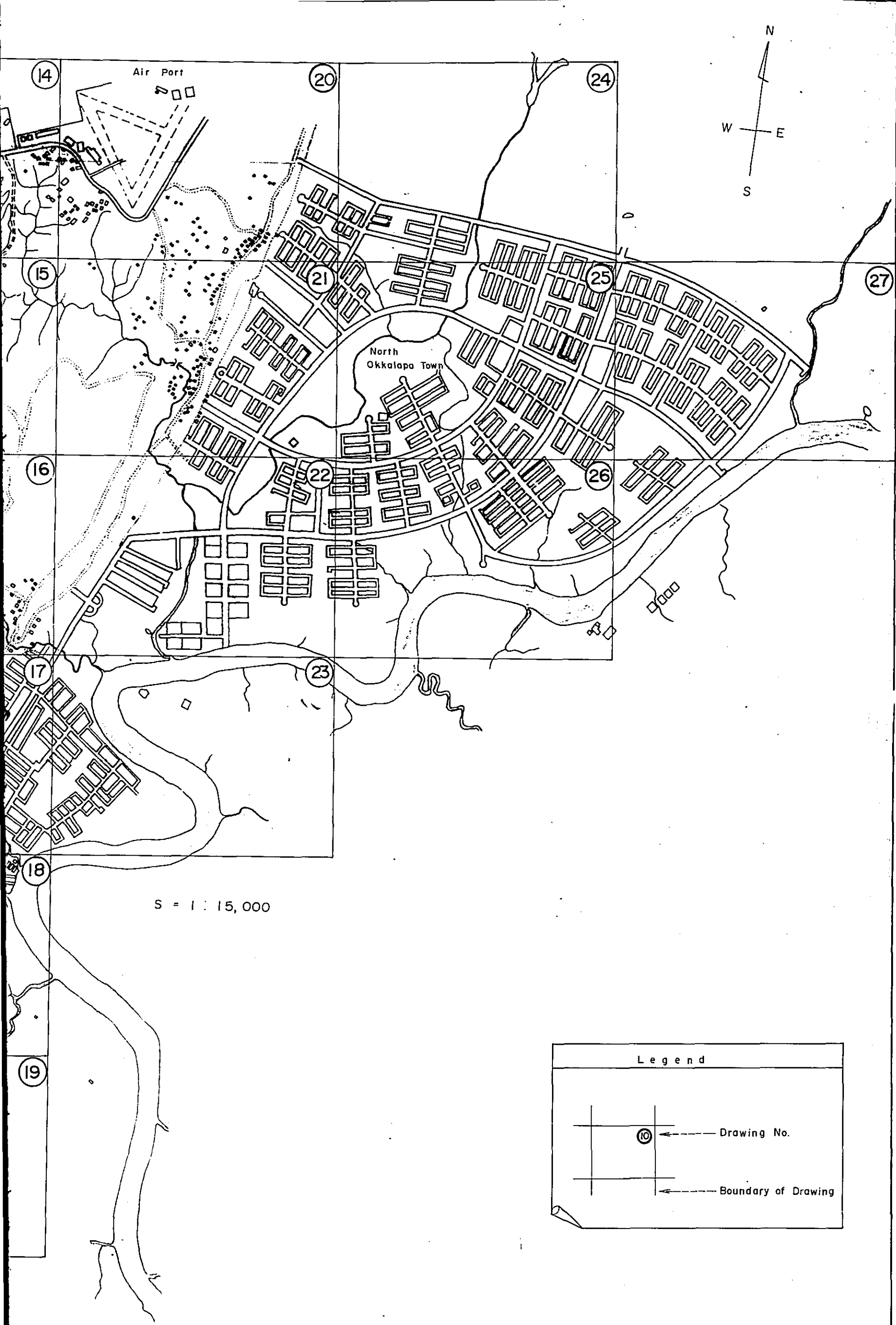

Legend

⑩	← Drawing No.
┌───┐	← Boundary of Drawing

Exchange	Mayangon
Drawing	Index Map of Subscriber Aerial Cable Plan
Drawing No.	III . 8 . I

Exchange	Mayangon
Drawing	Subscriber Aerial Cable Plan
Drawing No	III. 9. 1/27

TARMAINE CRAUN
 650x49 State
 Timber Board
 Factory Board
 496
 (85) 14
 (85) 14

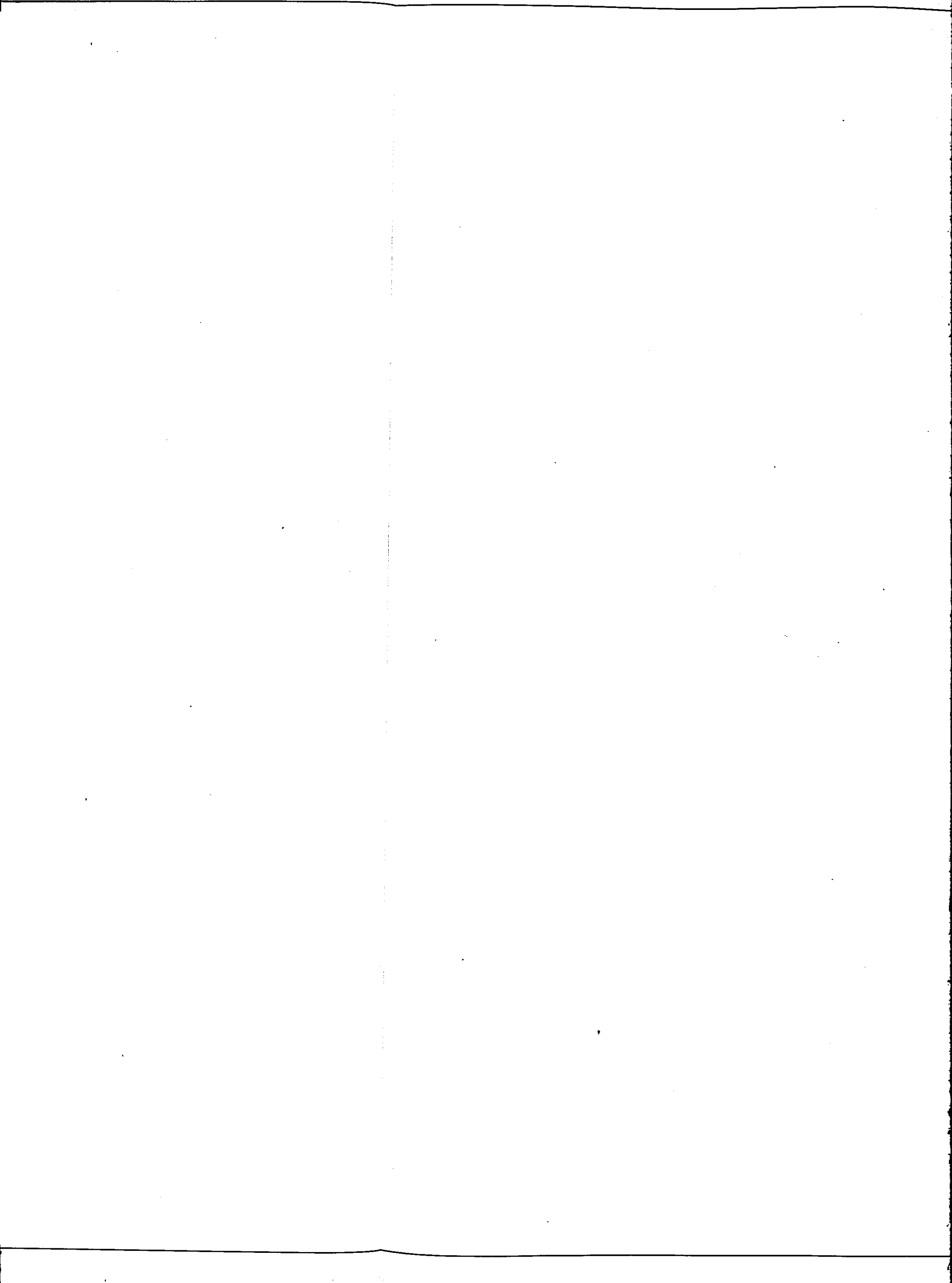

	①	4
	2	5

C 1 ~ 300

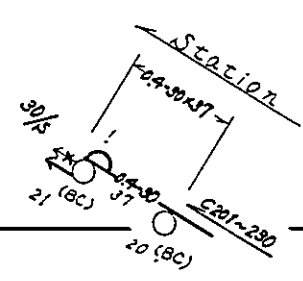

Thamling Chaung

Thamling

Okejin

C 1-300

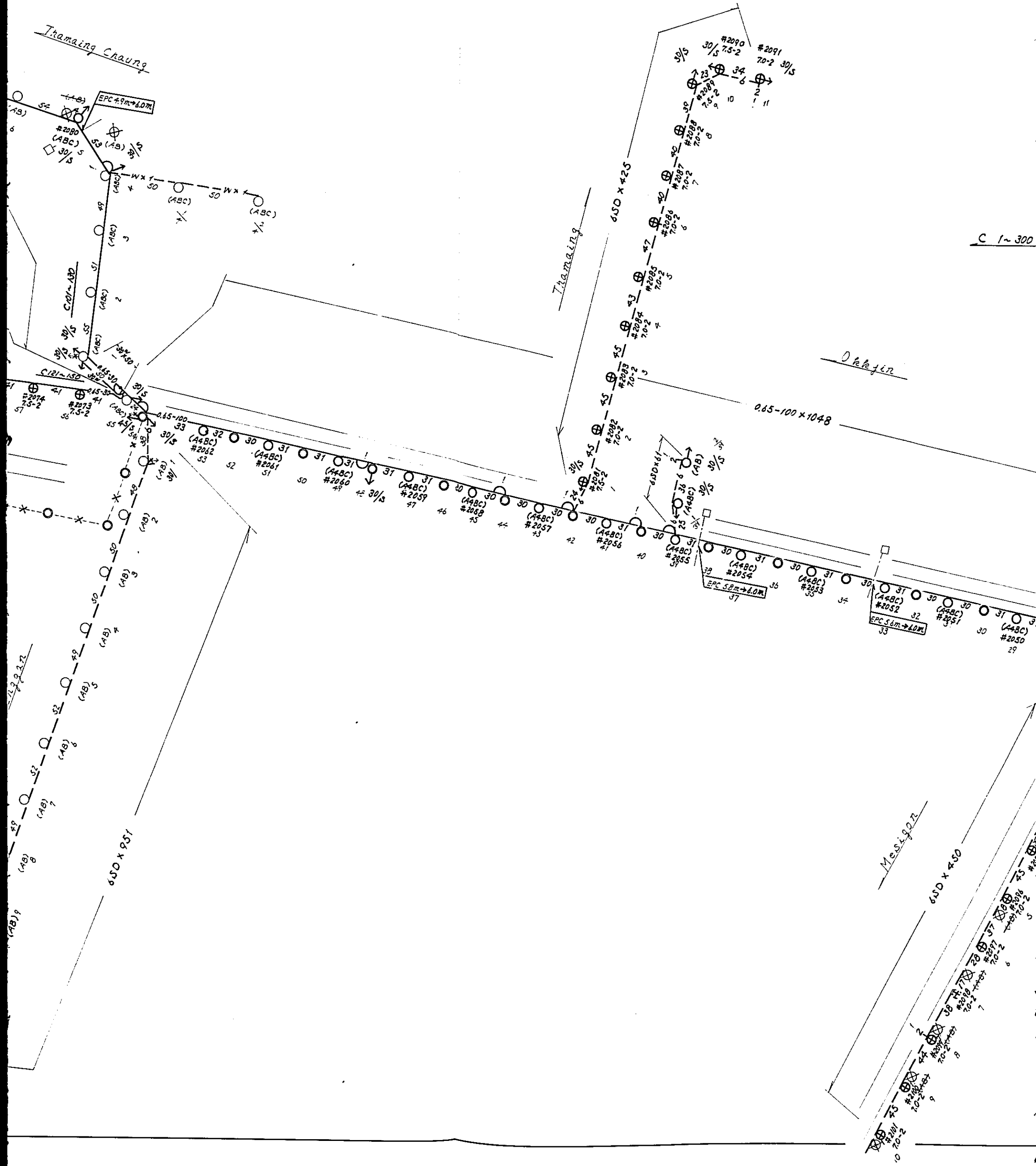

	1	4
	2	5
	3	6

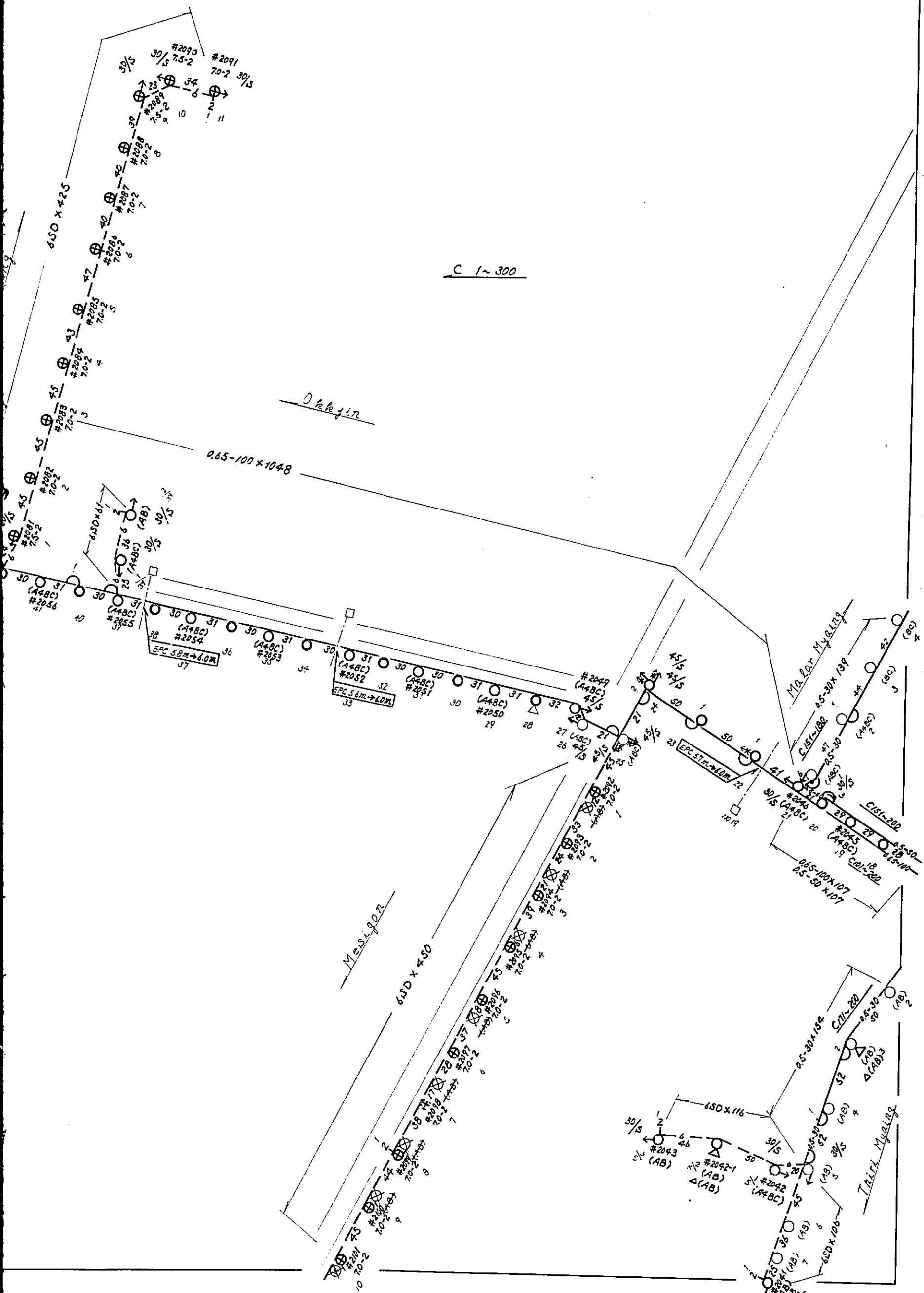
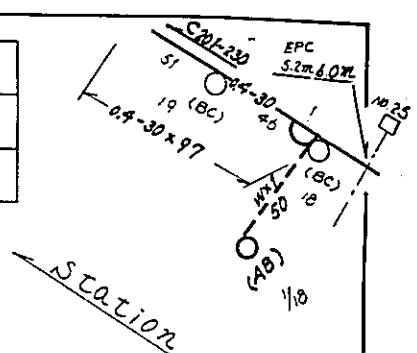

Mesigori

TALLE MYALBA

Ma. Lar. Myal. Lar.

C 1-300

D kkyin

0.65-100 x 1048

650 x 425

650 x 430

650 x 116

0.5-30 x 134

0.5-30 x 108

EPC 5.6m x 4.0m

EPC 5.7m x 4.0m

EPC 5.7m x 4.0m

0.5-100 x 107
0.5-30 x 107

0.5-30 x 139

0.5-30 x 107

0.5-30 x 108

0.5-30 x 108

0.5-30 x 108

0.5-30 x 108

0.5-30 x 108

#2090 30/S
#2091 70-2 30/S
#2088 70-2 6
#2087 70-2 7
#2086 70-2 6
#2085 70-2 5
#2084 70-2 4
#2083 70-2 3
#2082 70-2 2
#2081 70-2 1

#2056 (A, B, C)
#2055 (A, B, C)
#2054 (A, B, C)
#2053 (A, B, C)
#2052 (A, B, C)
#2051 (A, B, C)

#2049 (A, B, C)
#2048 (A, B, C)
#2047 (A, B, C)
#2046 (A, B, C)
#2045 (A, B, C)
#2044 (A, B, C)
#2043 (A, B, C)
#2042 (A, B, C)
#2041 (A, B, C)
#2040 (A, B, C)

#2039 (A, B, C)
#2038 (A, B, C)
#2037 (A, B, C)
#2036 (A, B, C)
#2035 (A, B, C)
#2034 (A, B, C)
#2033 (A, B, C)
#2032 (A, B, C)
#2031 (A, B, C)
#2030 (A, B, C)

#2029 (A, B, C)
#2028 (A, B, C)
#2027 (A, B, C)
#2026 (A, B, C)
#2025 (A, B, C)
#2024 (A, B, C)
#2023 (A, B, C)
#2022 (A, B, C)
#2021 (A, B, C)
#2020 (A, B, C)

#2019 (A, B, C)
#2018 (A, B, C)
#2017 (A, B, C)
#2016 (A, B, C)
#2015 (A, B, C)
#2014 (A, B, C)
#2013 (A, B, C)
#2012 (A, B, C)
#2011 (A, B, C)
#2010 (A, B, C)

#2009 (A, B, C)
#2008 (A, B, C)
#2007 (A, B, C)
#2006 (A, B, C)
#2005 (A, B, C)
#2004 (A, B, C)
#2003 (A, B, C)
#2002 (A, B, C)
#2001 (A, B, C)
#2000 (A, B, C)

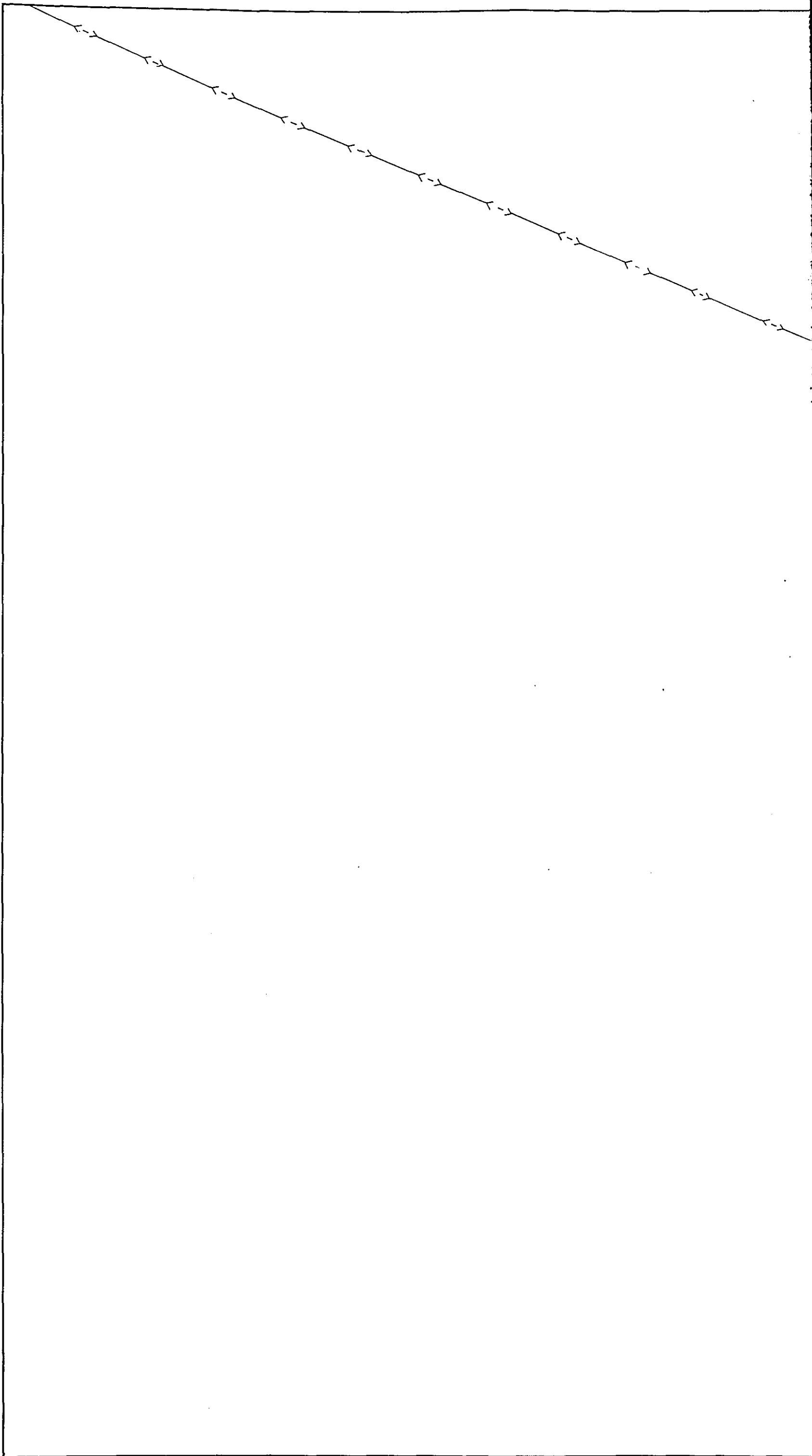

Mcs. 802

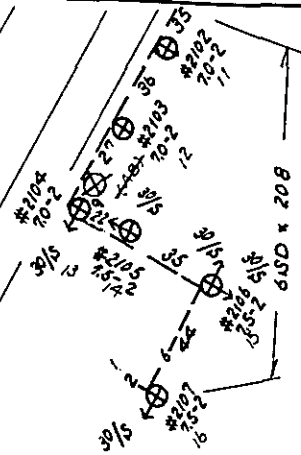

C 1 ~ 300

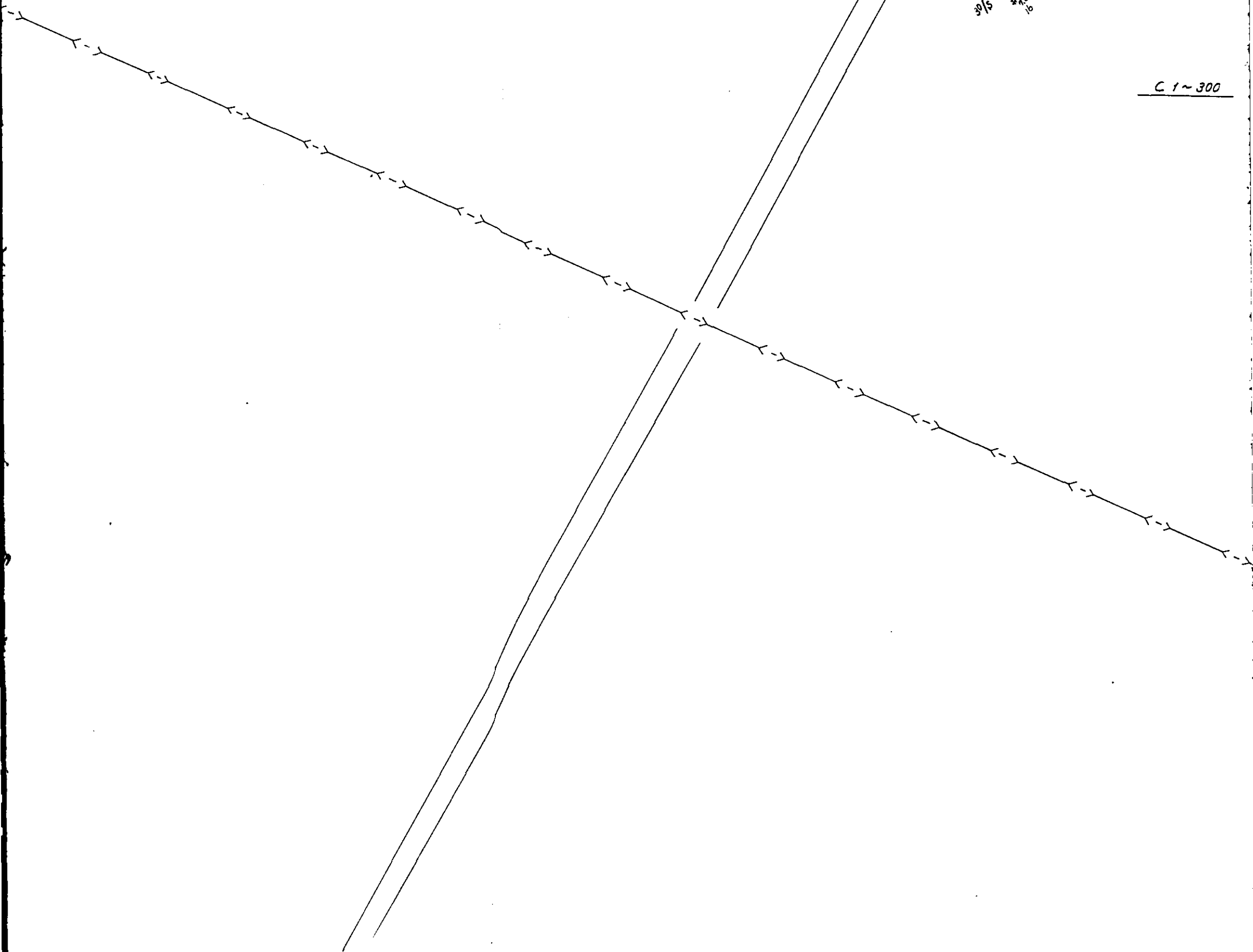

	2	5
	3	6
		7

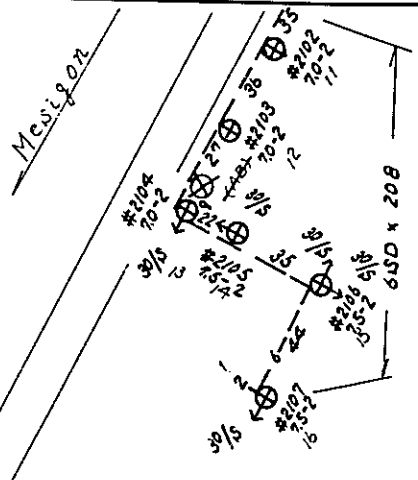

C 1 ~ 300

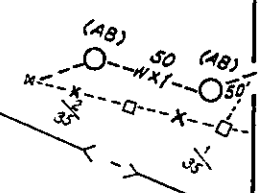

Exchange	Mayangon
Drawing	Subscriber Aerial Cable Plan
Drawing No.	III. 9. 3/27

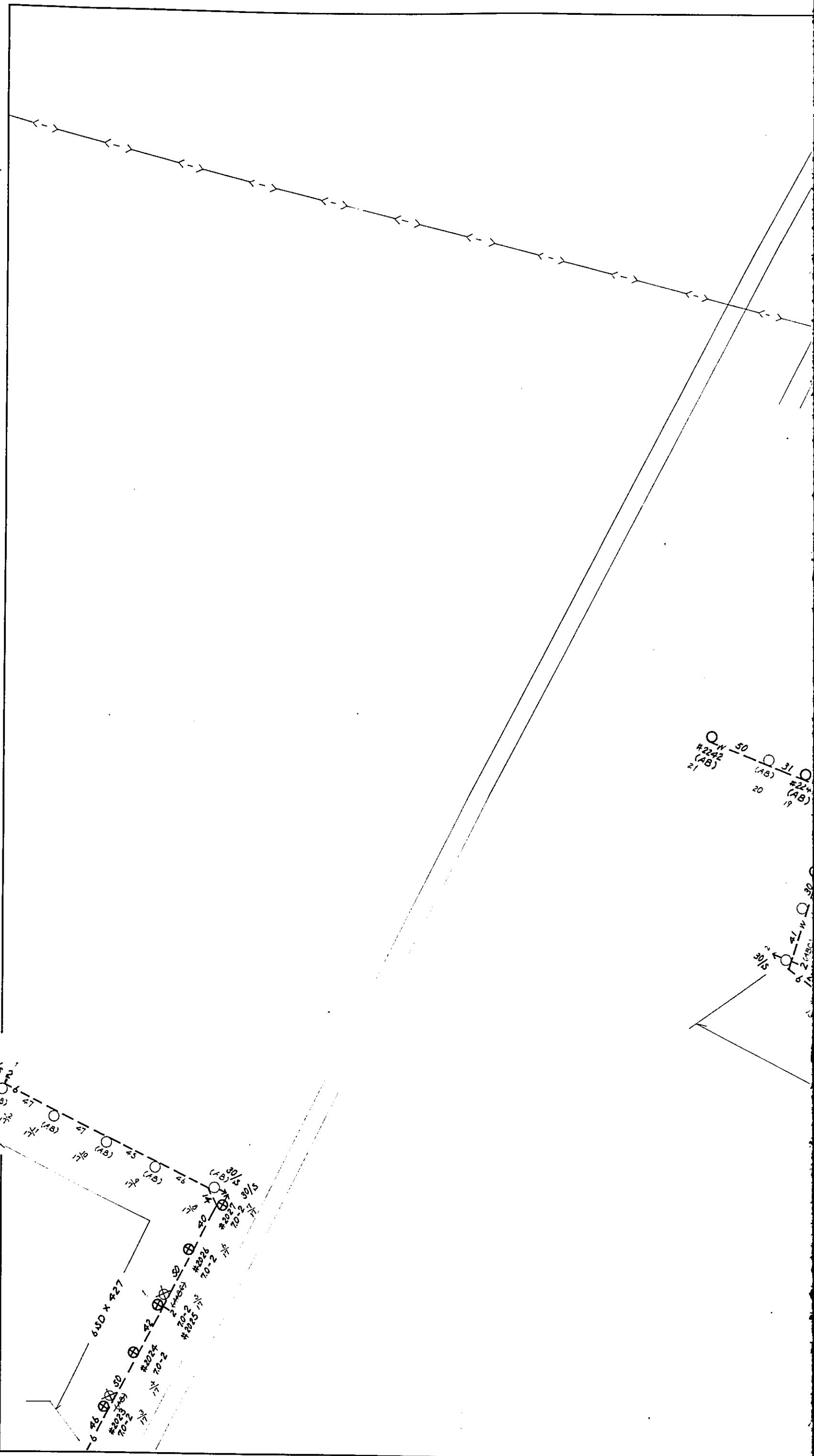

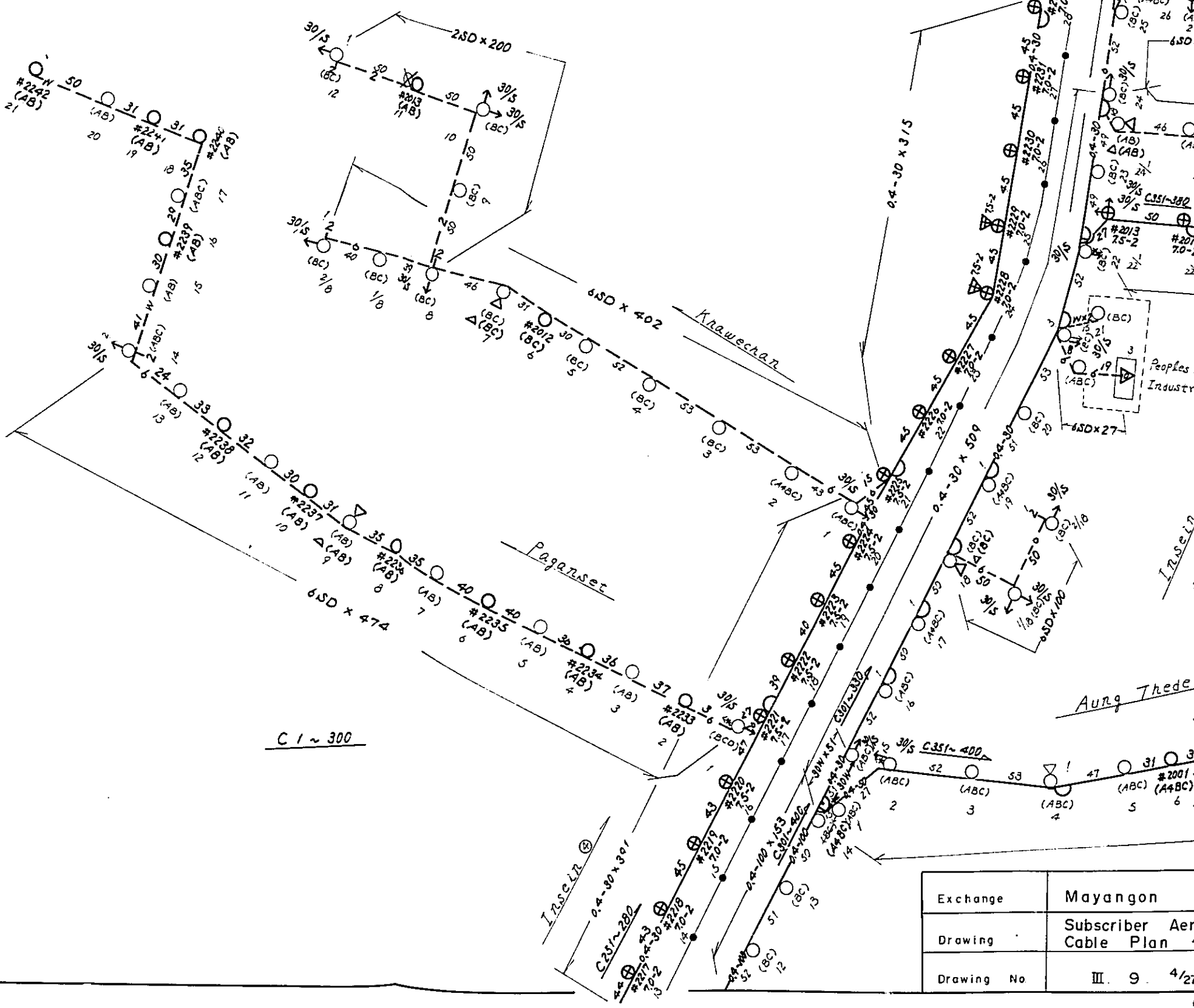

C 1 ~ 300

Exchange	Mayangon
Drawing	Subscriber Aer Cable Plan
Drawing No	III. 9. 4/27

1	4	8
2	5	9

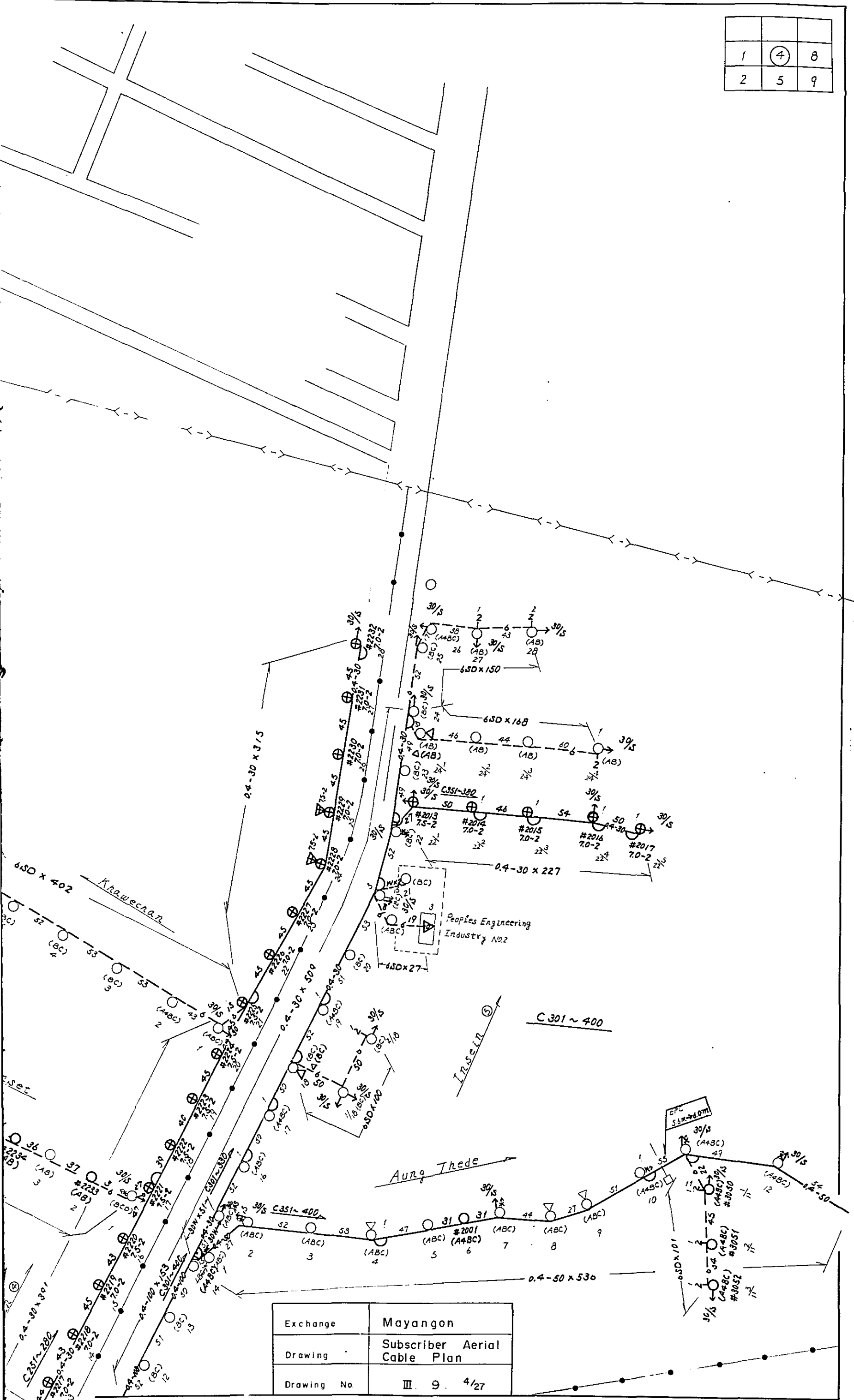

Exchange	Mayangon
Drawing	Subscriber Aerial Cable Plan
Drawing No	III 9 4/27

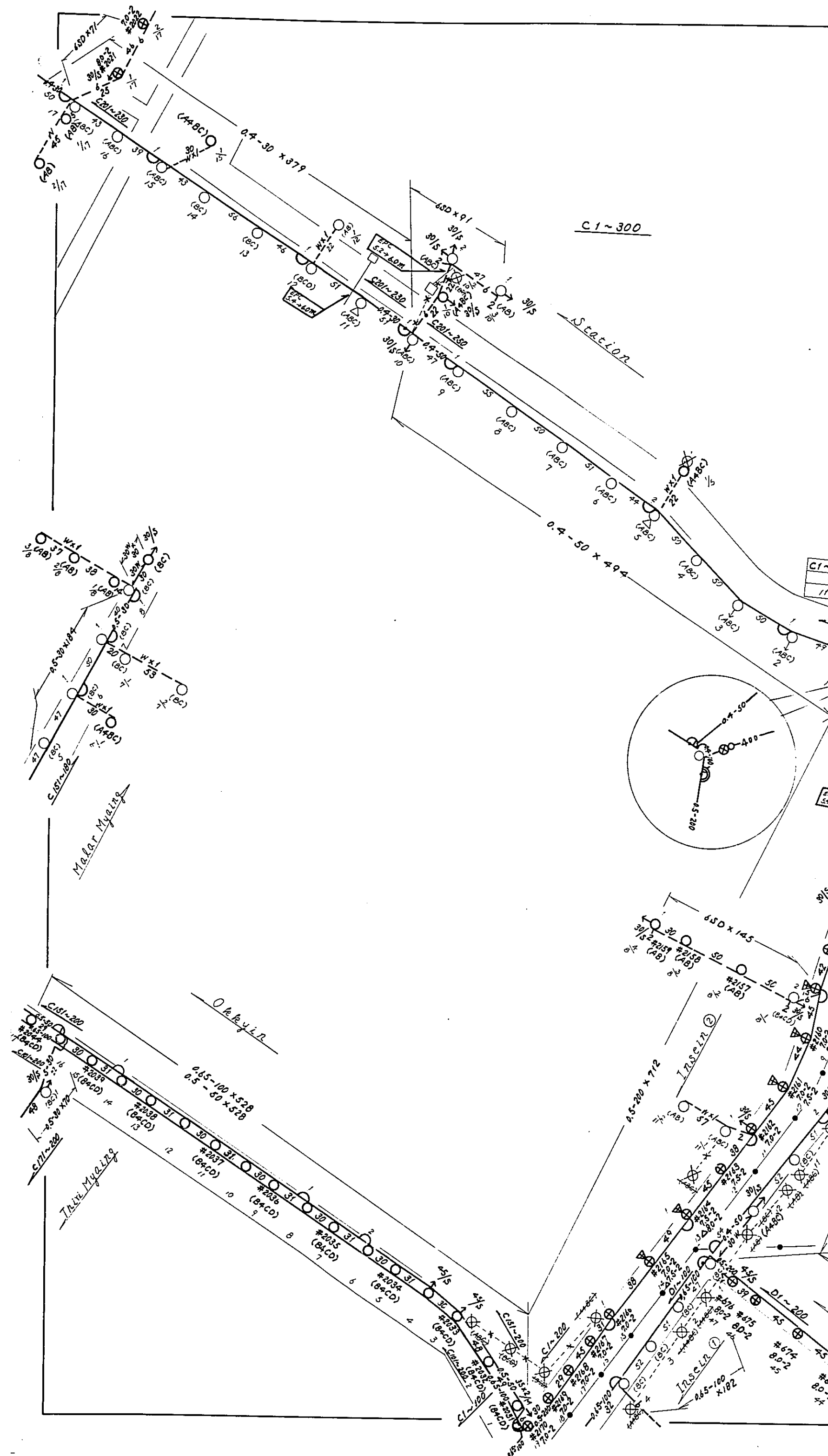

C1-300

STATION

C1-300	97
	118

Makar Myazin

Tain Myazin

Okeyin

Insein (2)

Insein (1)

DI-200

1	4	8
2	5	9
3	6	10

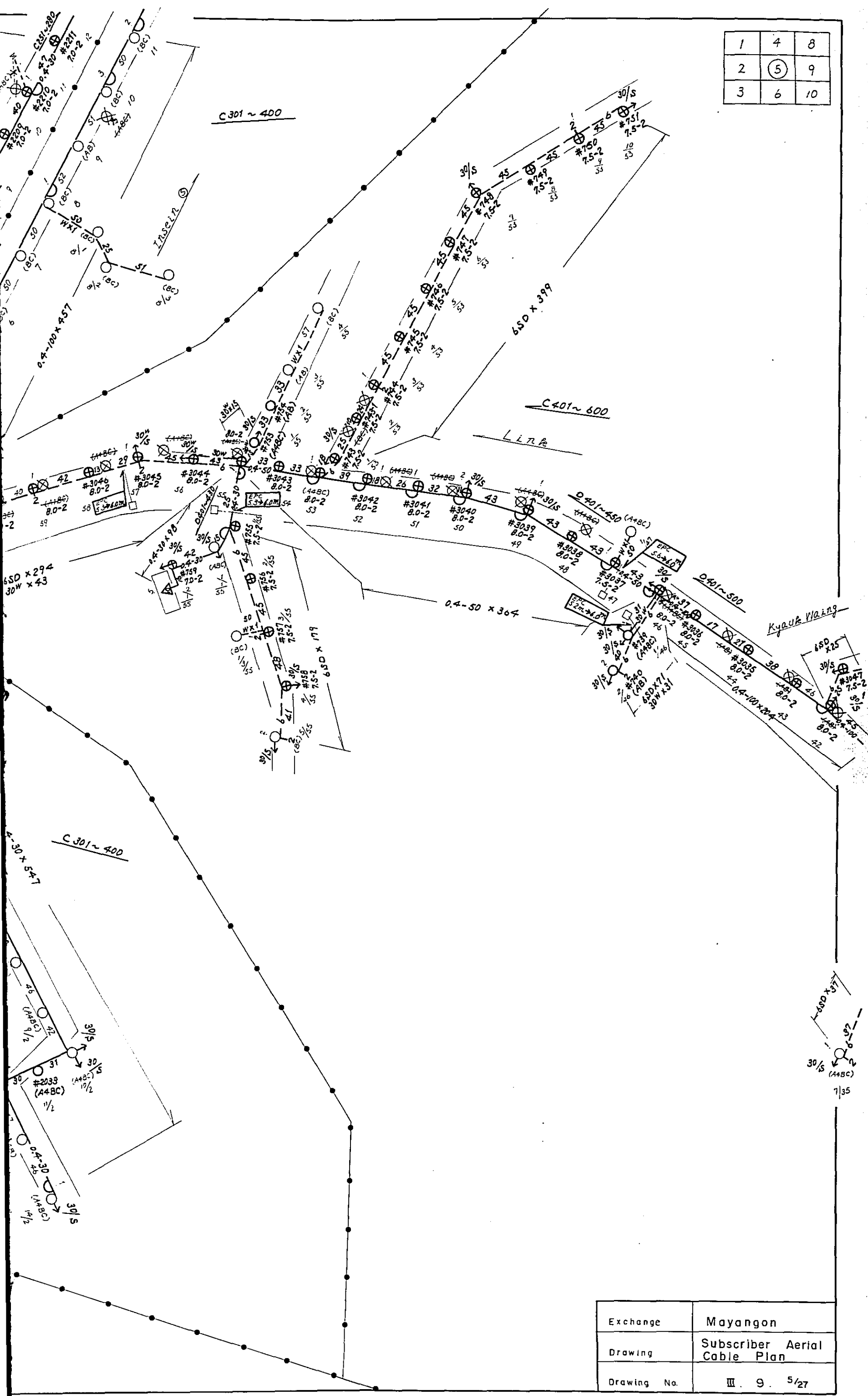

Exchange	Mayangon
Drawing	Subscriber Aerial Cable Plan
Drawing No.	III. 9. 5/27

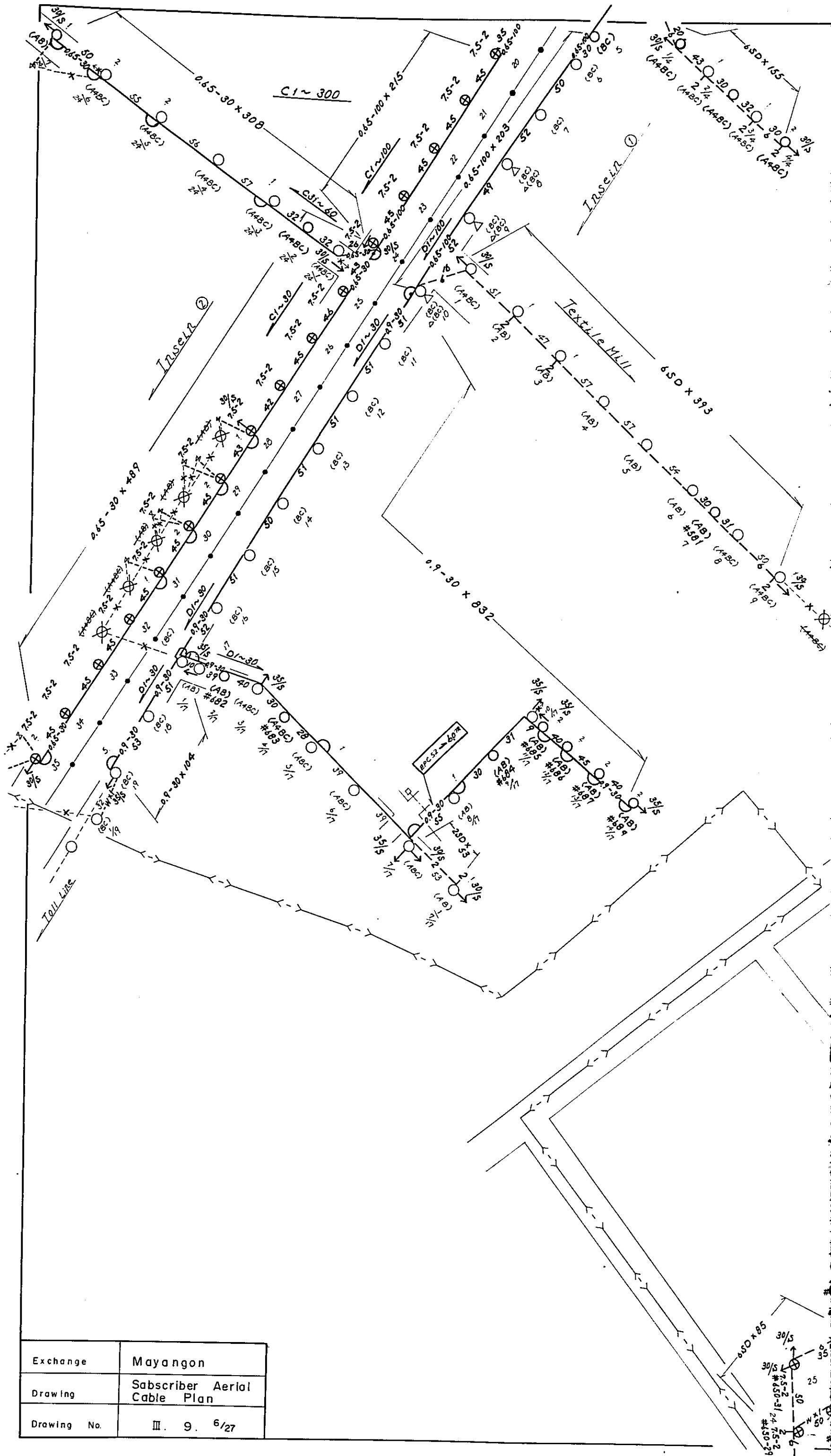

Exchange	Mayangon
Drawing	Subscriber Aerial Cable Plan
Drawing No.	III. 9. 6/27

2	5	9
3	(6)	10
	7	11

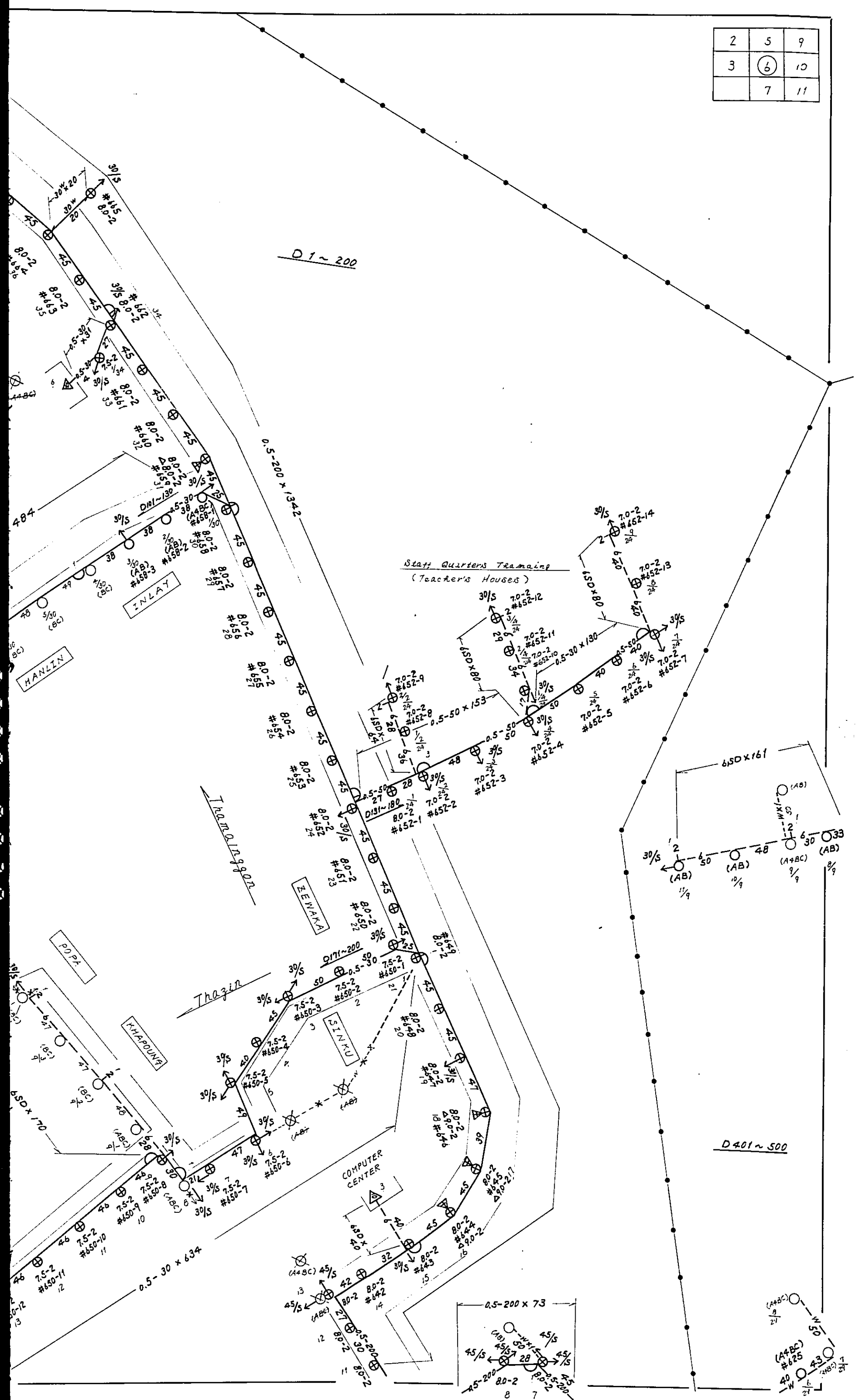

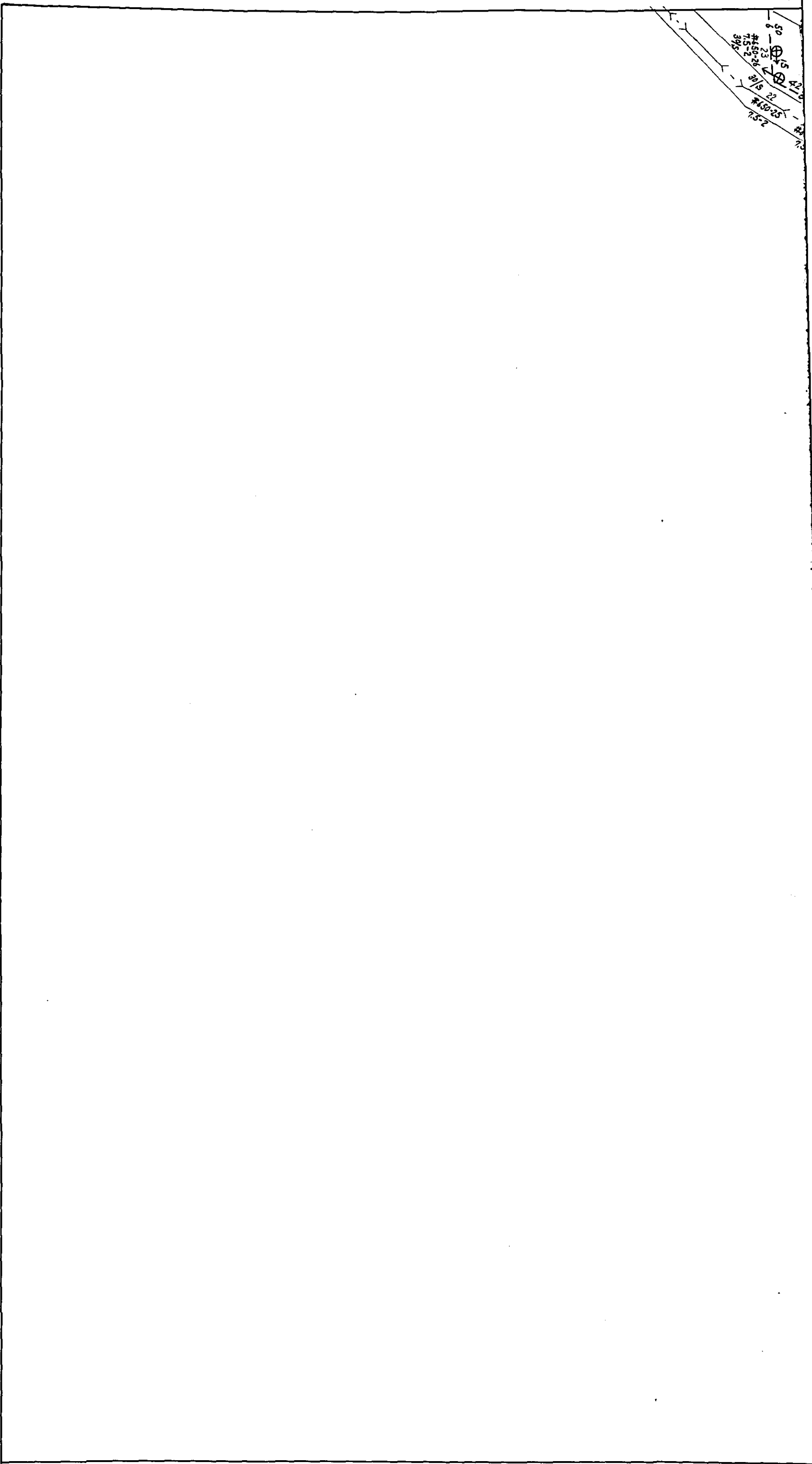

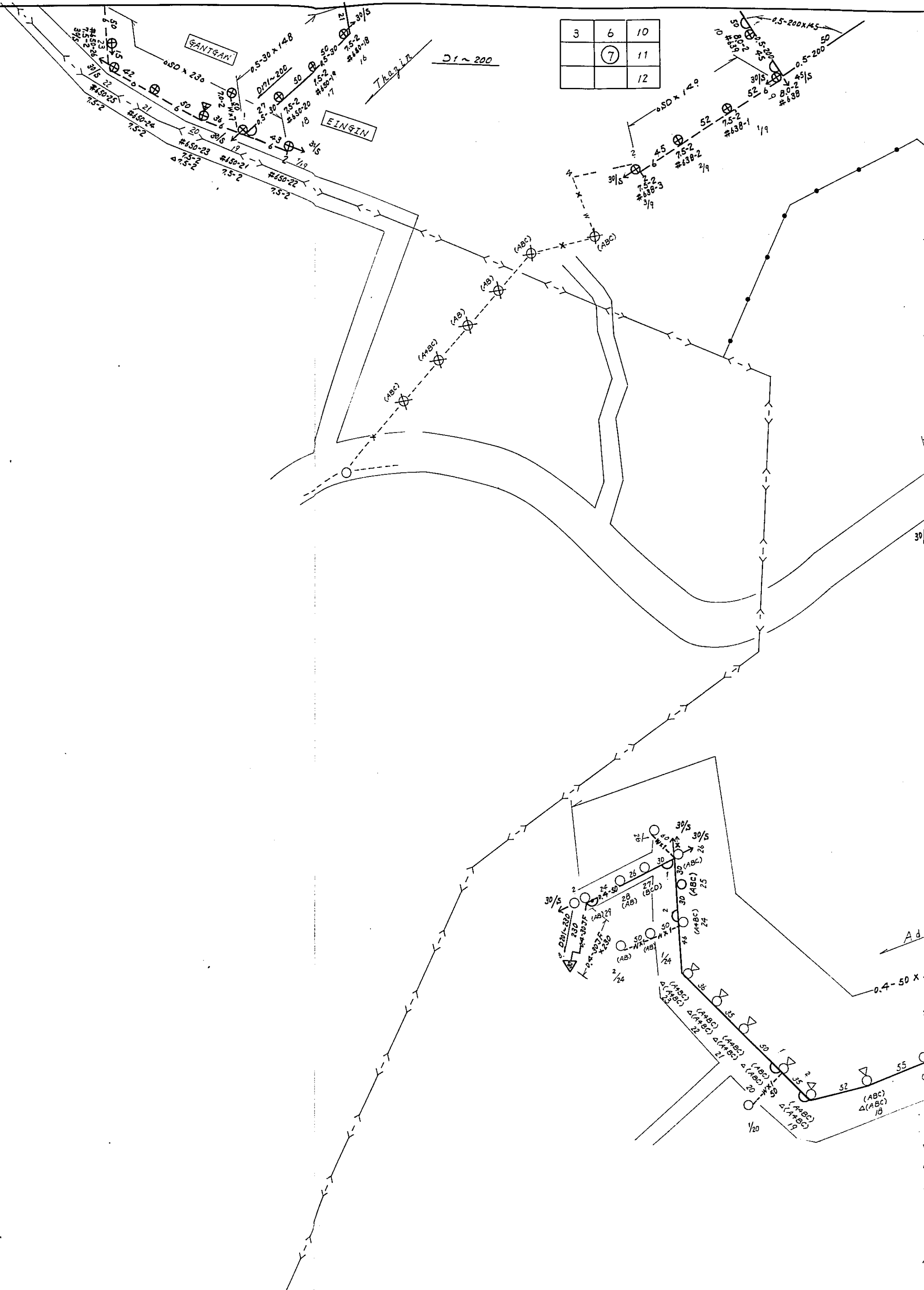

3	6	10
	7	11
		12

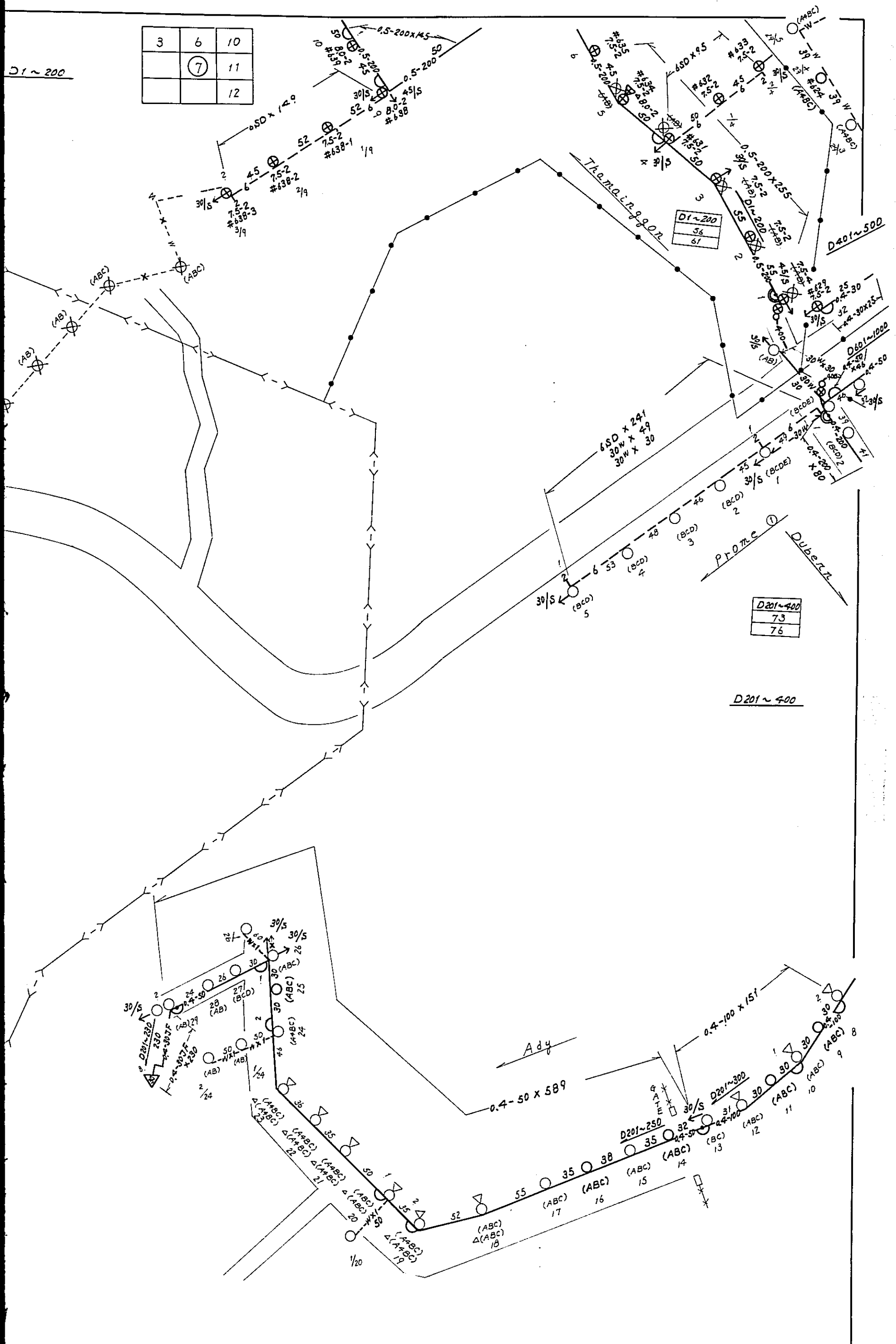

Exchange	Mayangon
Drawing	Subscriber Aerial Cable Plan
Drawing No.	III. 9. 7/27

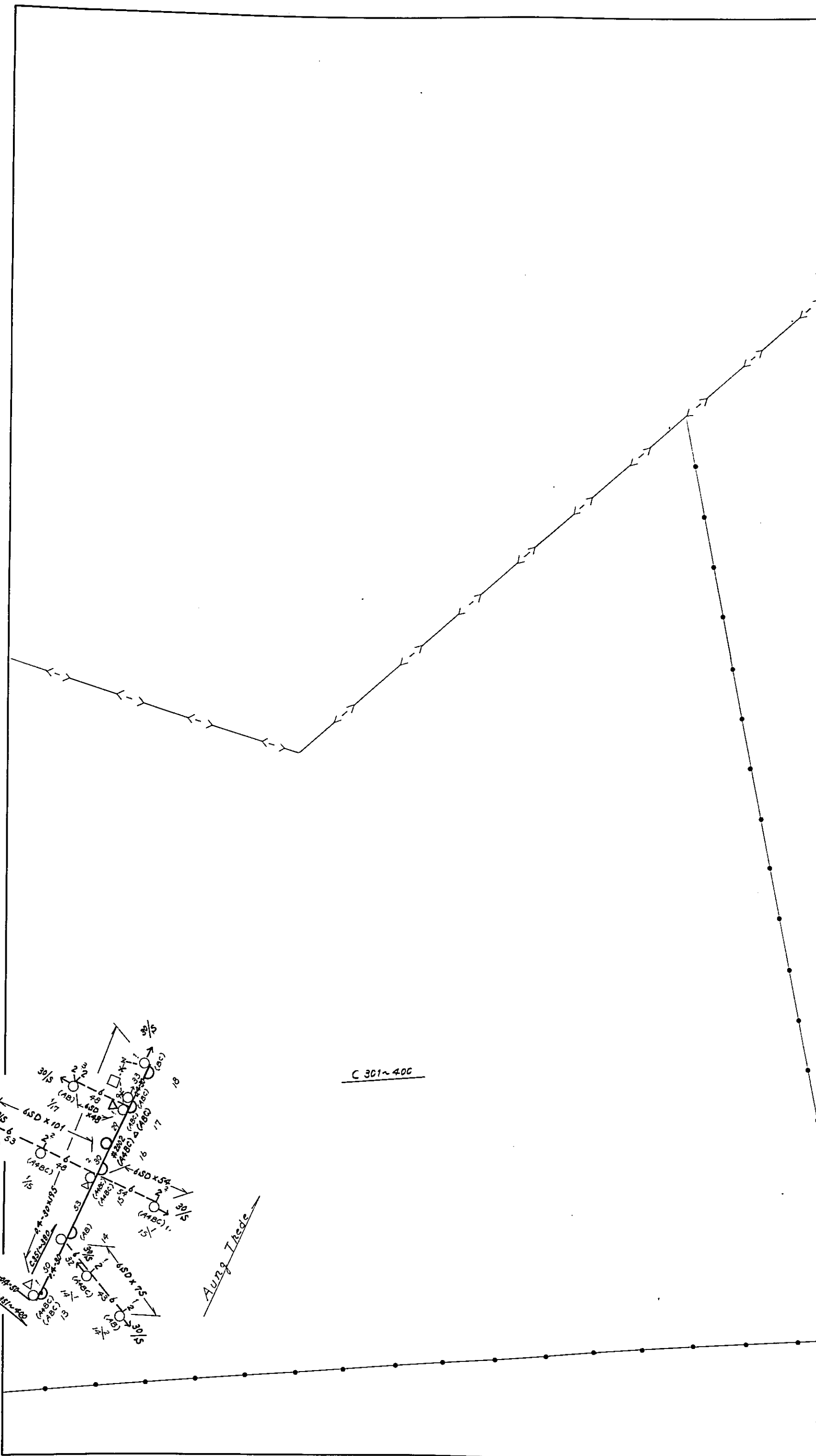

C 301~400

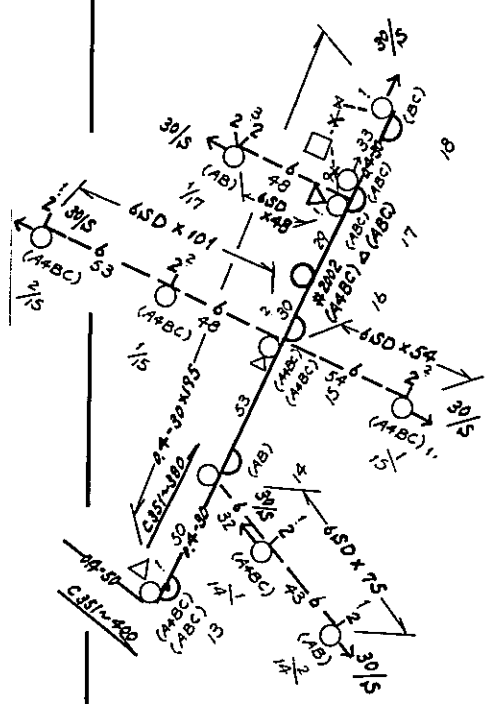

Auszug Tabelle

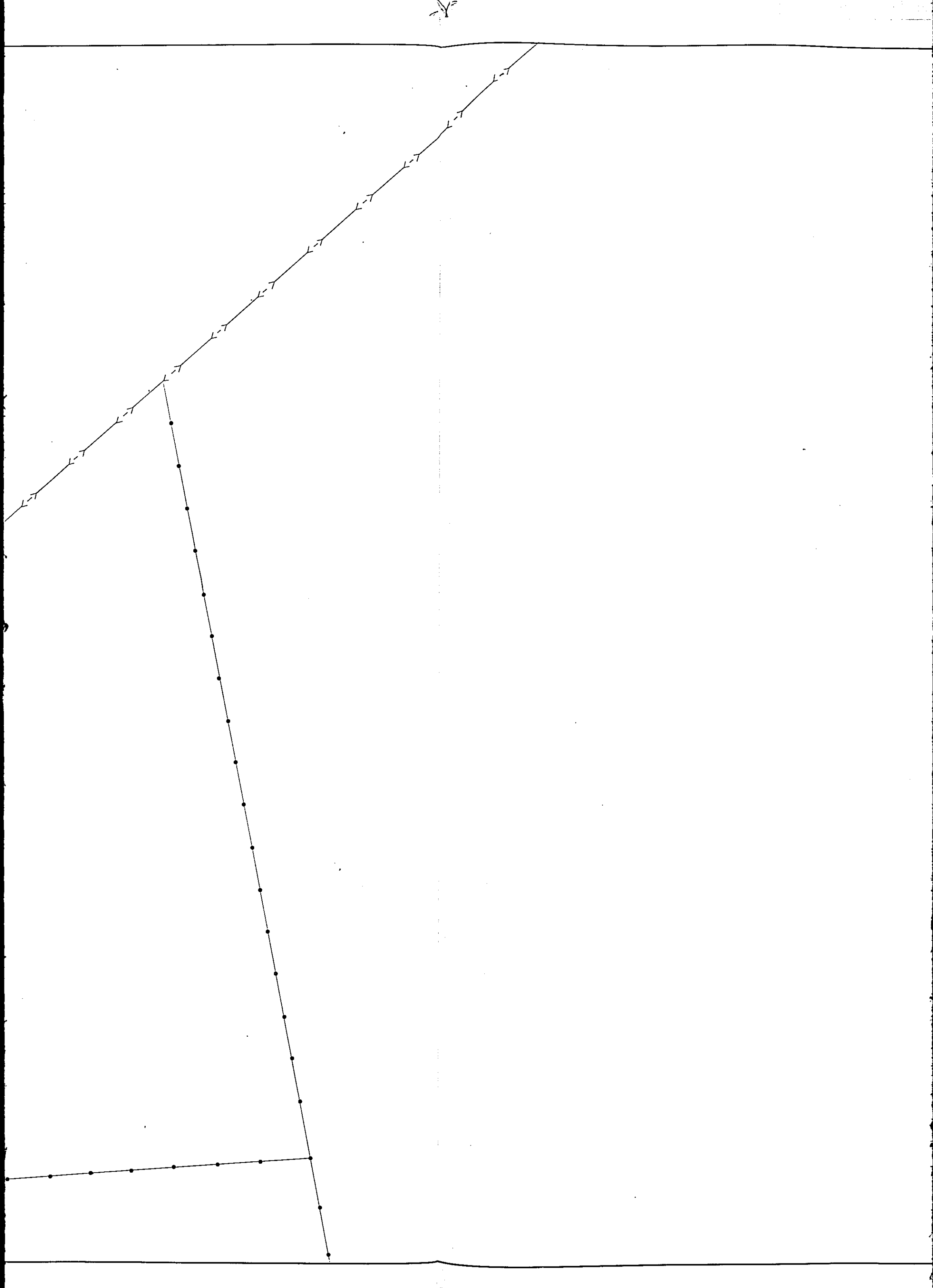

		14
4	8	15
5	9	16

Prone 5

D 601 ~ 1000

Exchange	Mayangon
Drawing	Subscriber Aerial Cable Plan
Drawing No	III. 9. 8/27

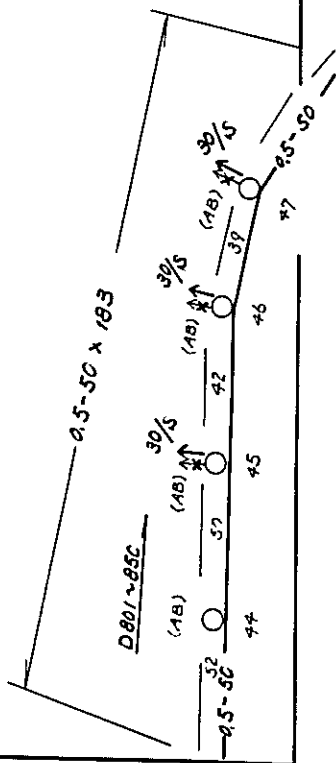

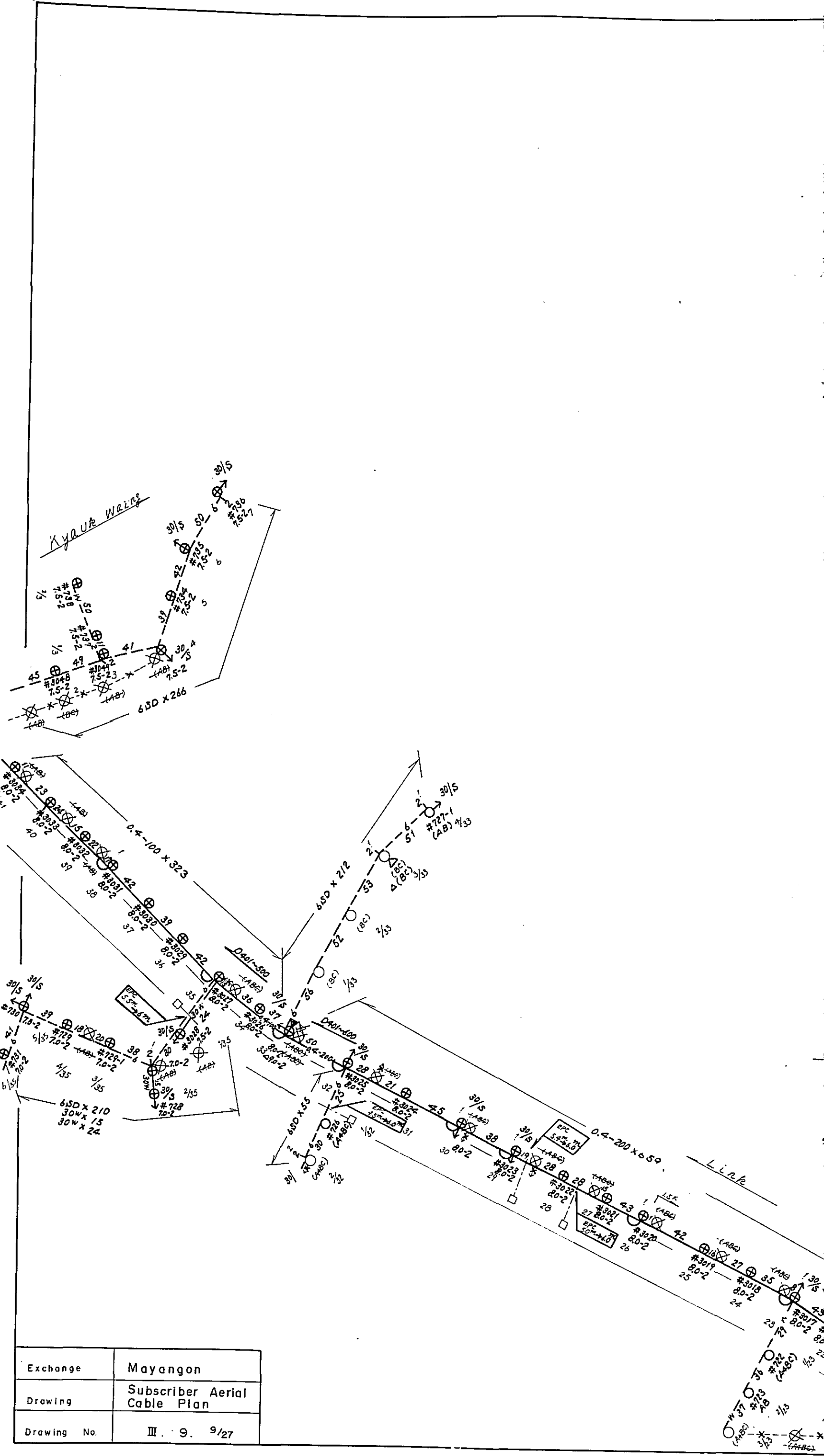

Exchange	Mayangon
Drawing	Subscriber Aerial Cable Plan
Drawing No.	III. 9. 9/27

4	8	15
5	9	16
6	10	17

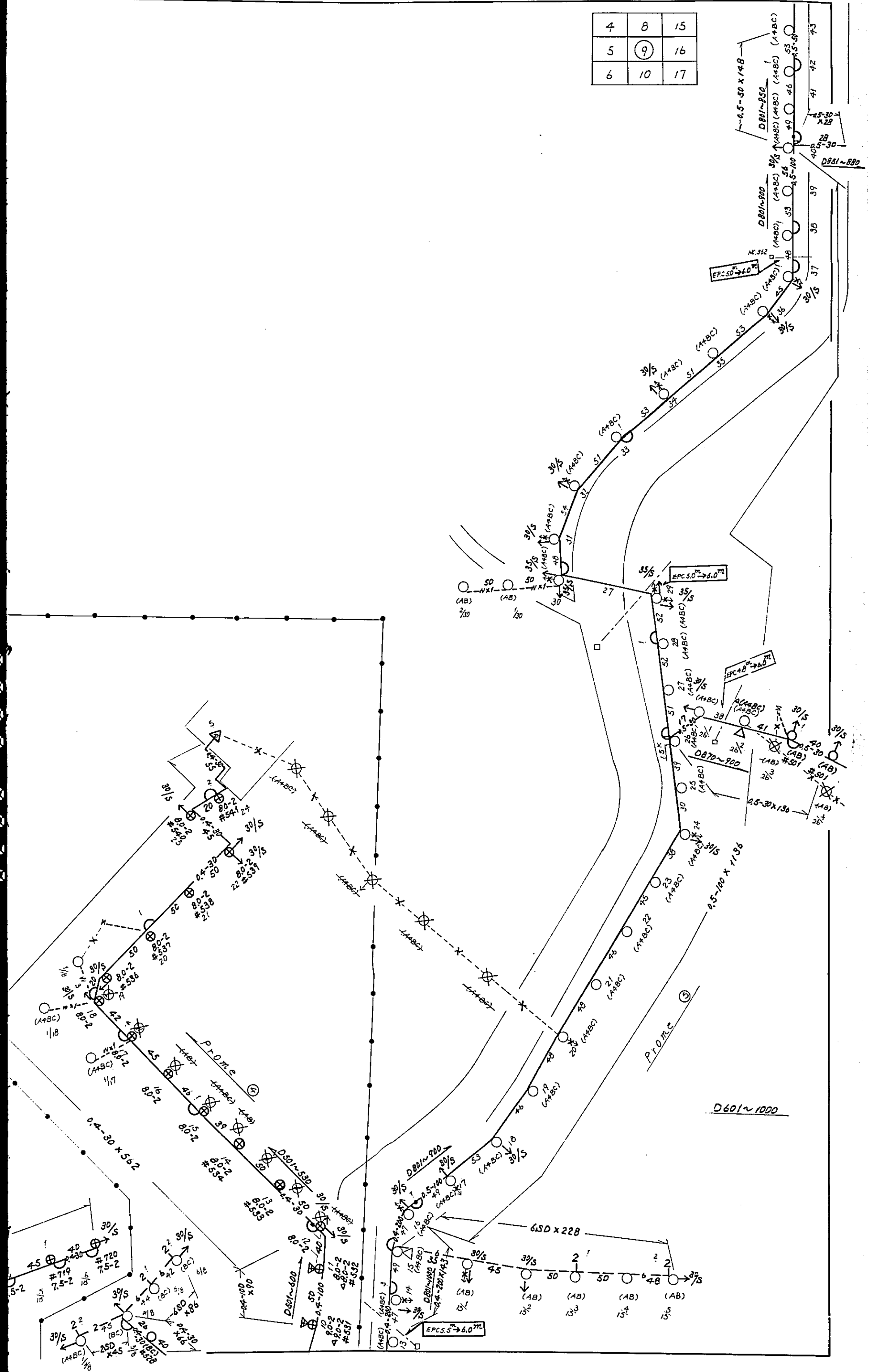

D601~1000

EPC 5.0" → 6.0"

EPC 5.0" → 6.0"

EPC 5.0" → 6.0"

D801~800

D801~900

D801~850

D801~800

D801~750

D801~700

D801~650

D801~600

D801~550

D801~500

D801~450

D801~400

D801~350

D801~300

D801~250

D801~200

D801~150

D801~100

D801~50

D801~0

D801~-50

D801~-100

D801~-150

D801~-200

D801~-250

D801~-300

D801~-350

D801~-400

D801~-450

D801~-500

D801~-550

D801~-600

D801~-650

D801~-700

D801~-750

D801~-800

D801~-850

D801~-900

D801~-950

D801~-1000

D801~-1050

D801~-1100

D801~-1150

D801~-1200

D801~-1250

D801~-1300

D801~-1350

D801~-1400

D801~-1450

D801~-1500

D801~-1550

D801~-1600

D801~-1650

D801~-1700

D801~-1750

D801~-1800

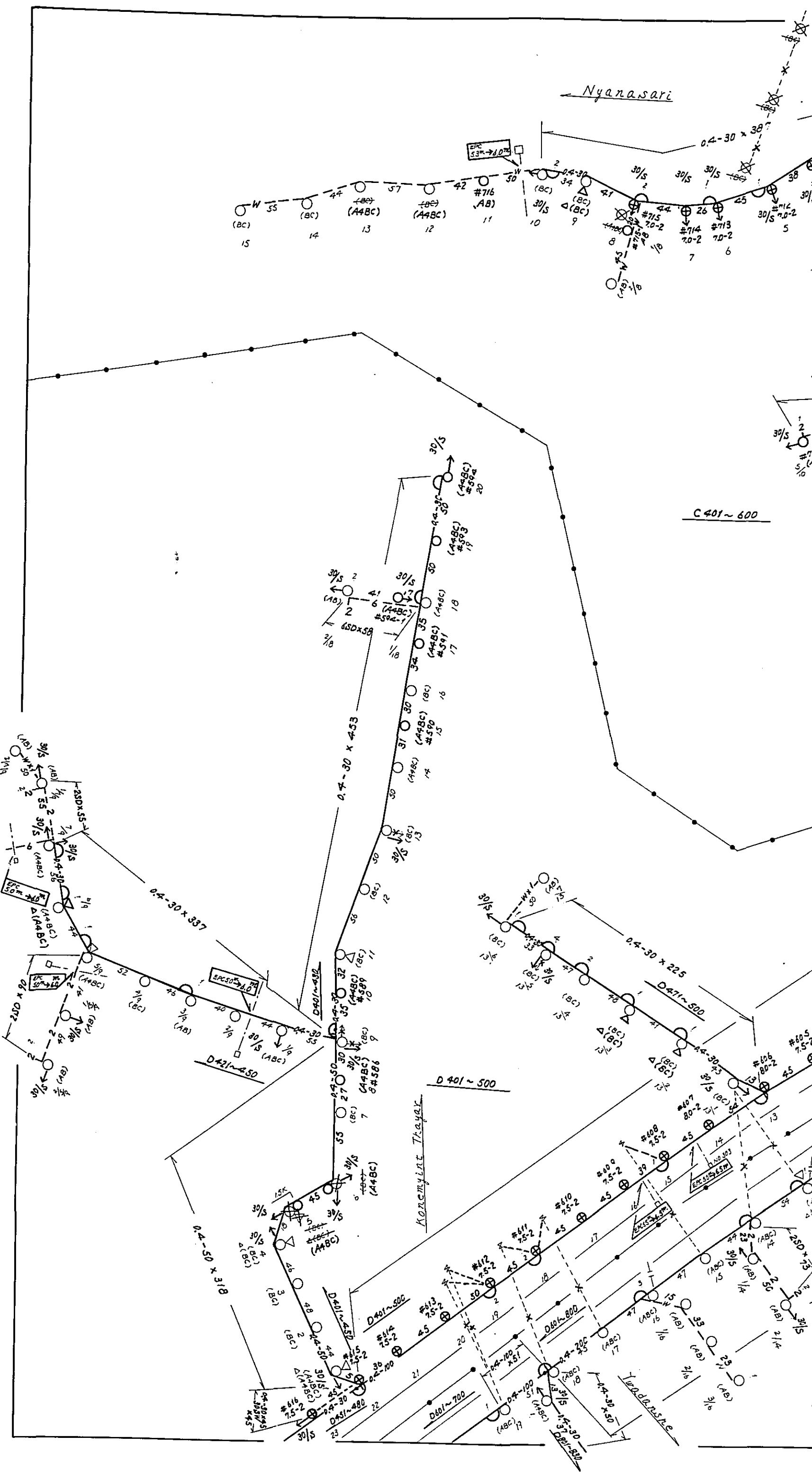

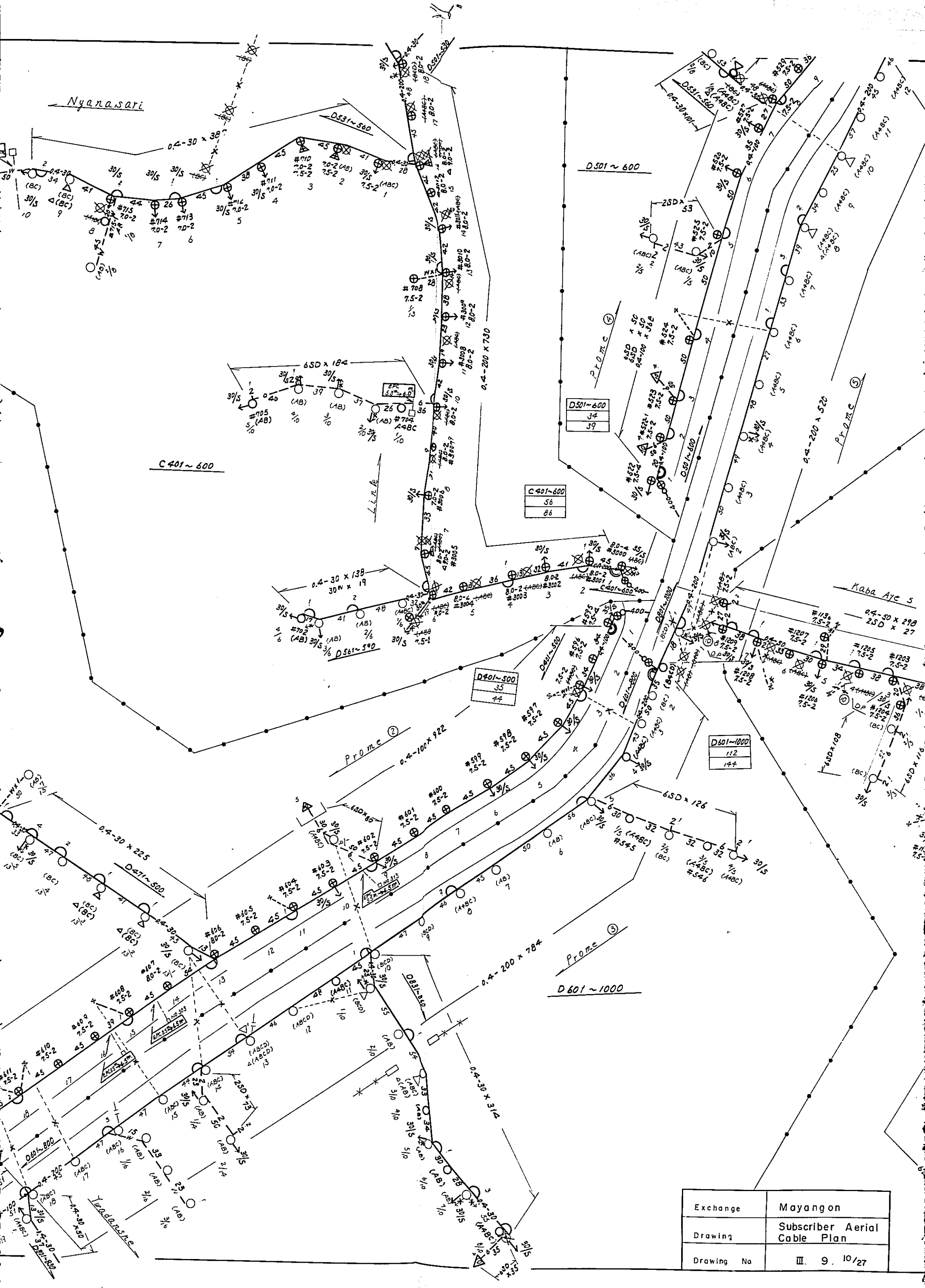

Nyanasari

Kaba Aye 5

Exchange	Mayangon
Drawing	Subscriber Aerial Cable Plan
Drawing No	III. 9. 10/27

5	9	16
6	10	17
7	11	18

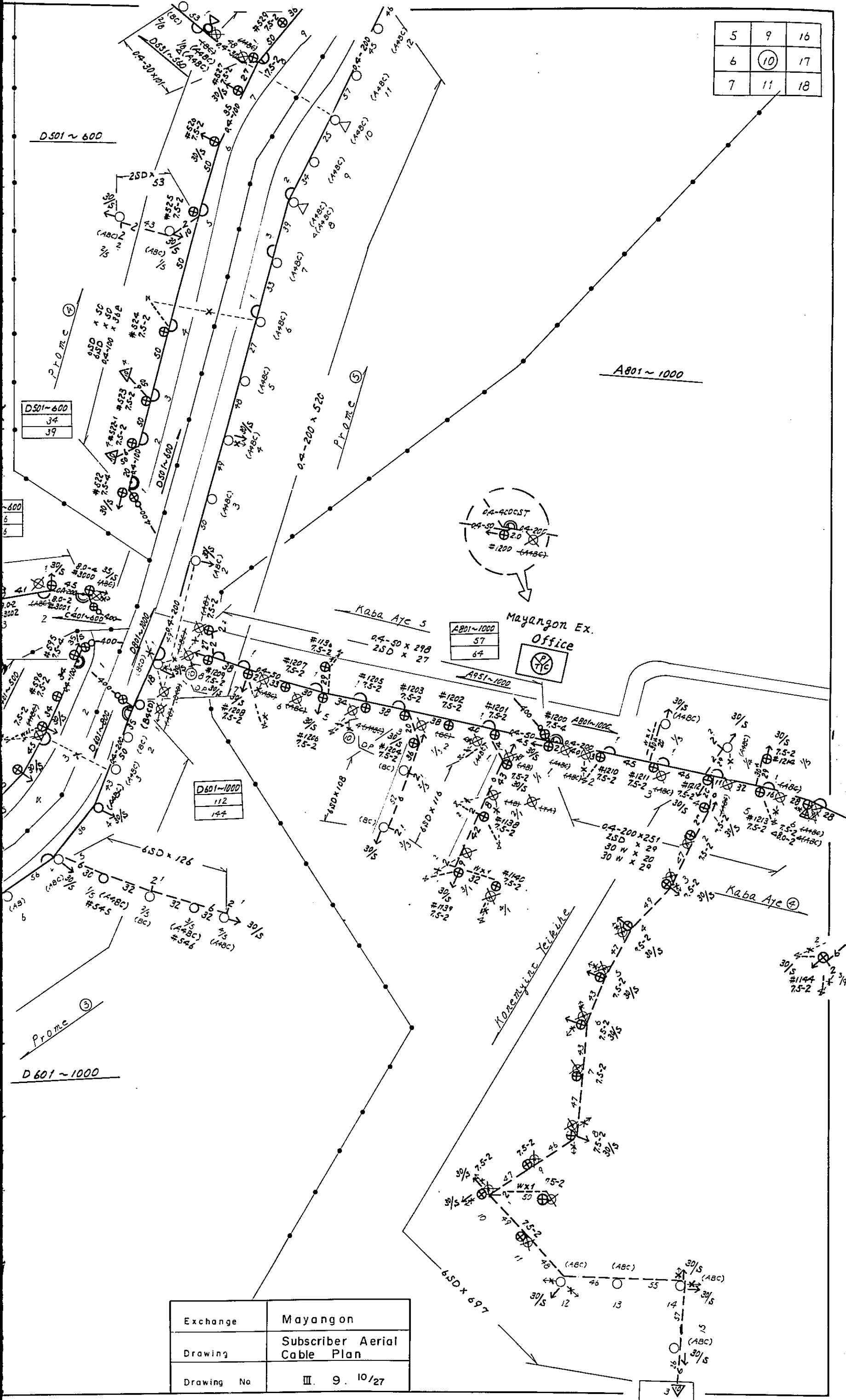

Exchange	Mayangon
Drawing	Subscriber Aerial Cable Plan
Drawing No	III. 9. 10/27

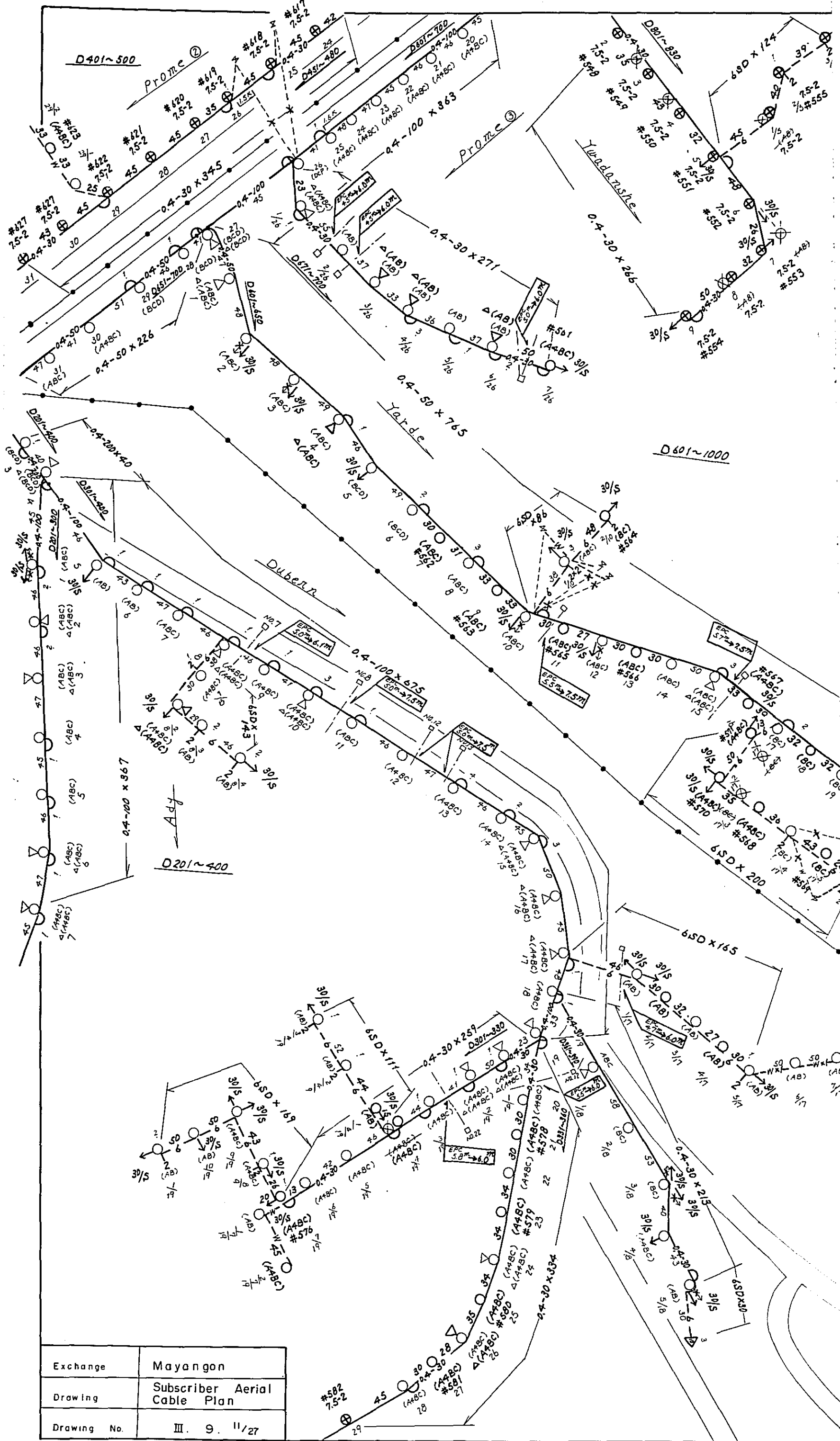

Exchange	Mayangon
Drawing	Subscriber Aerial Cable Plan
Drawing No.	III. 9. 11/27



D 601~1000

A 401~600

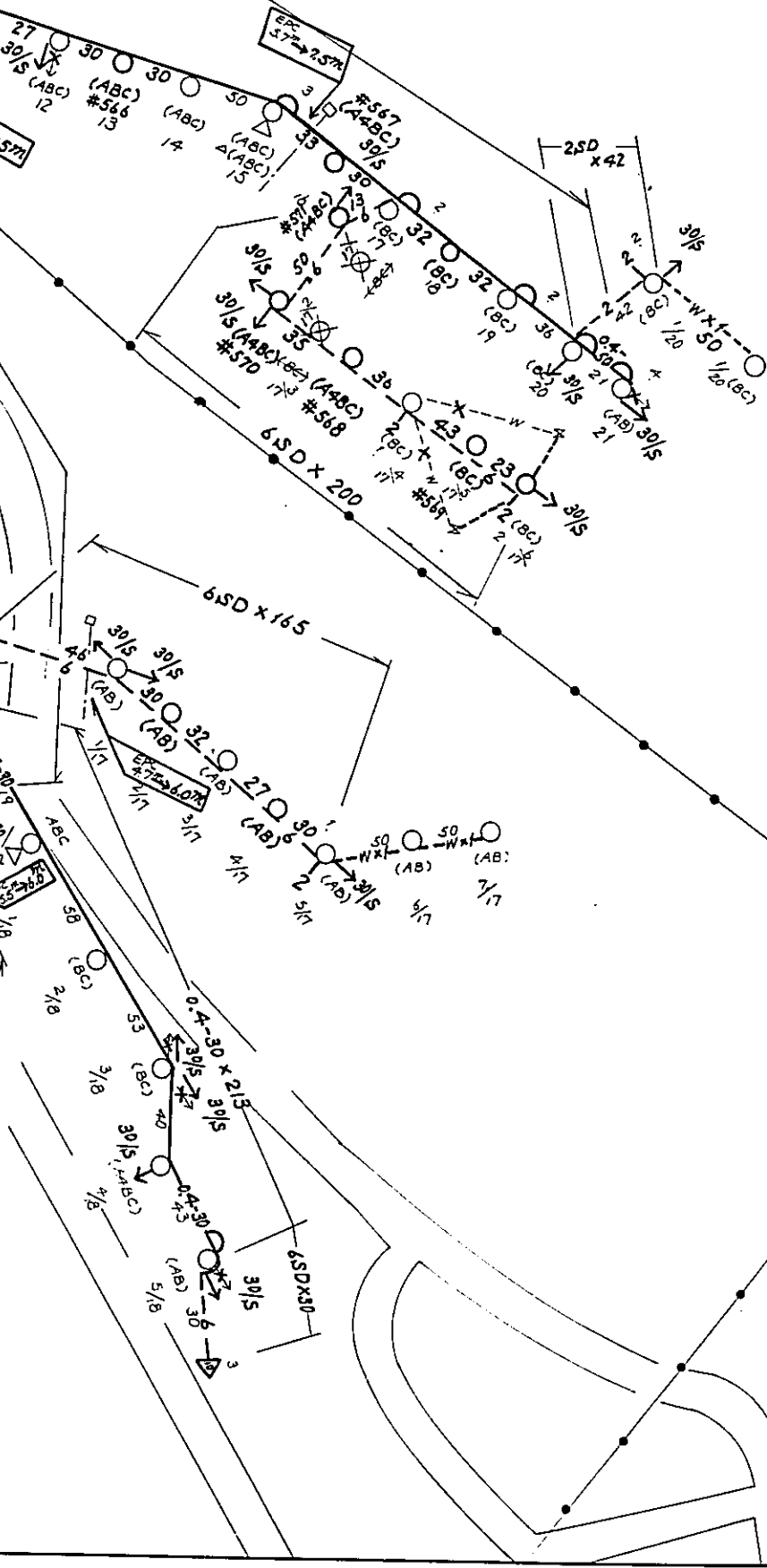
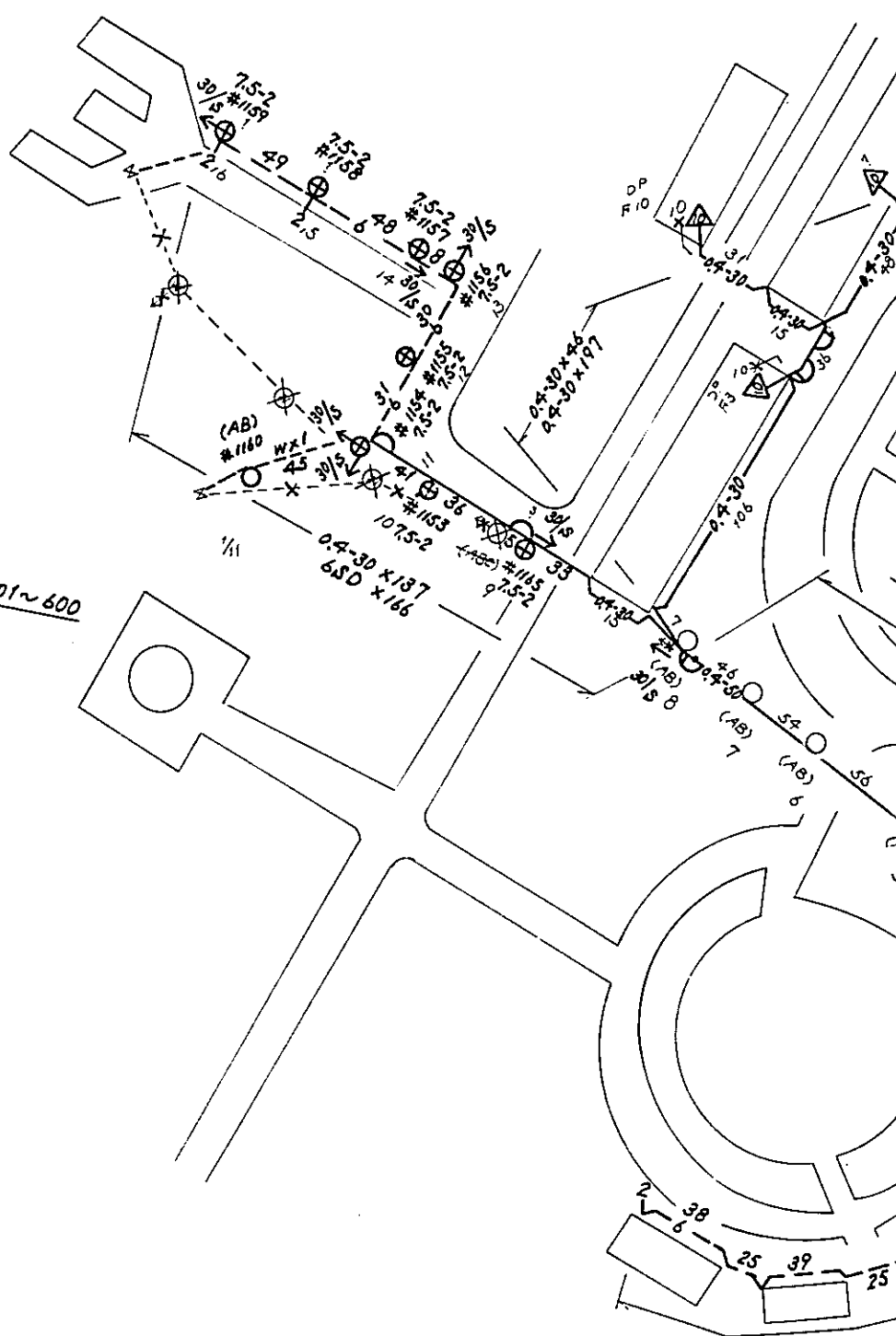
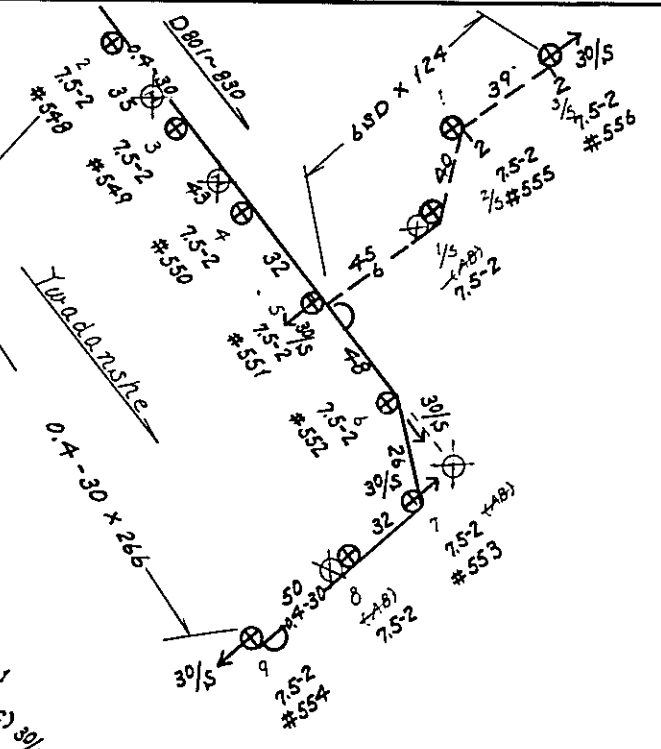

6	10	17
7	(11)	18
	12	19

A 601 ~ 700

A 401 ~ 600

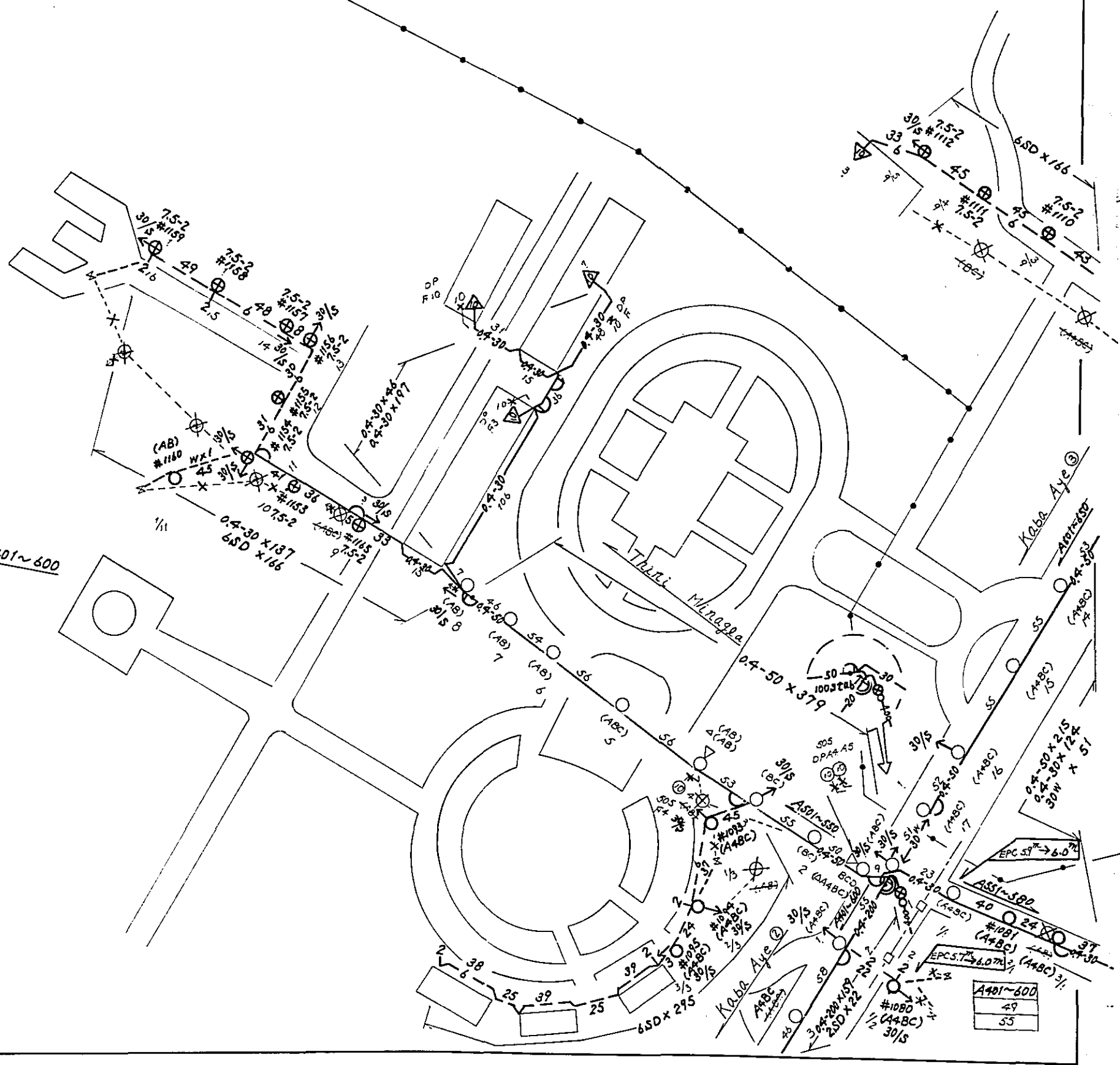

A 401 ~ 600
49
55

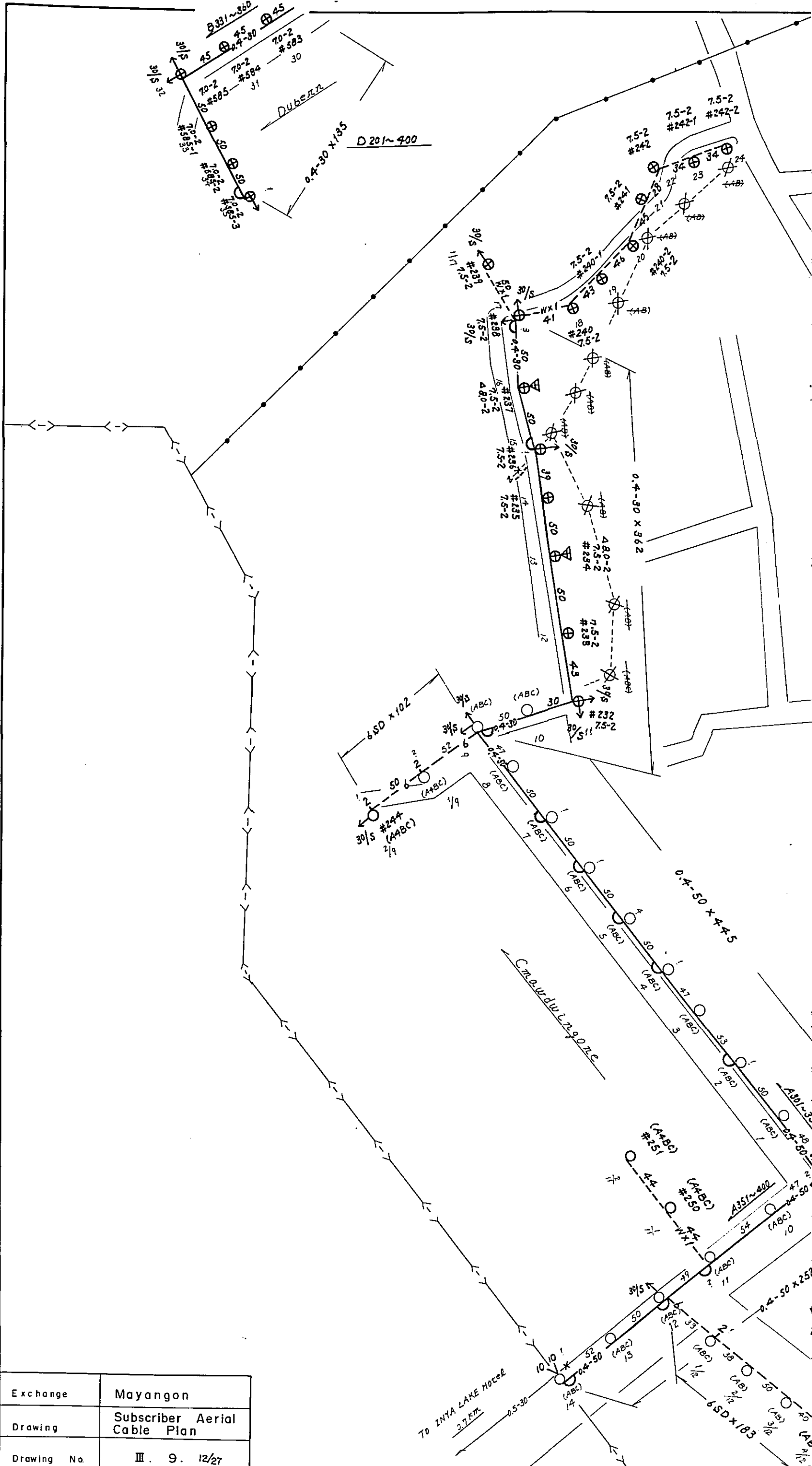

Exchange	Mayangon
Drawing	Subscriber Aerial Cable Plan
Drawing No.	III. 9. 12/27

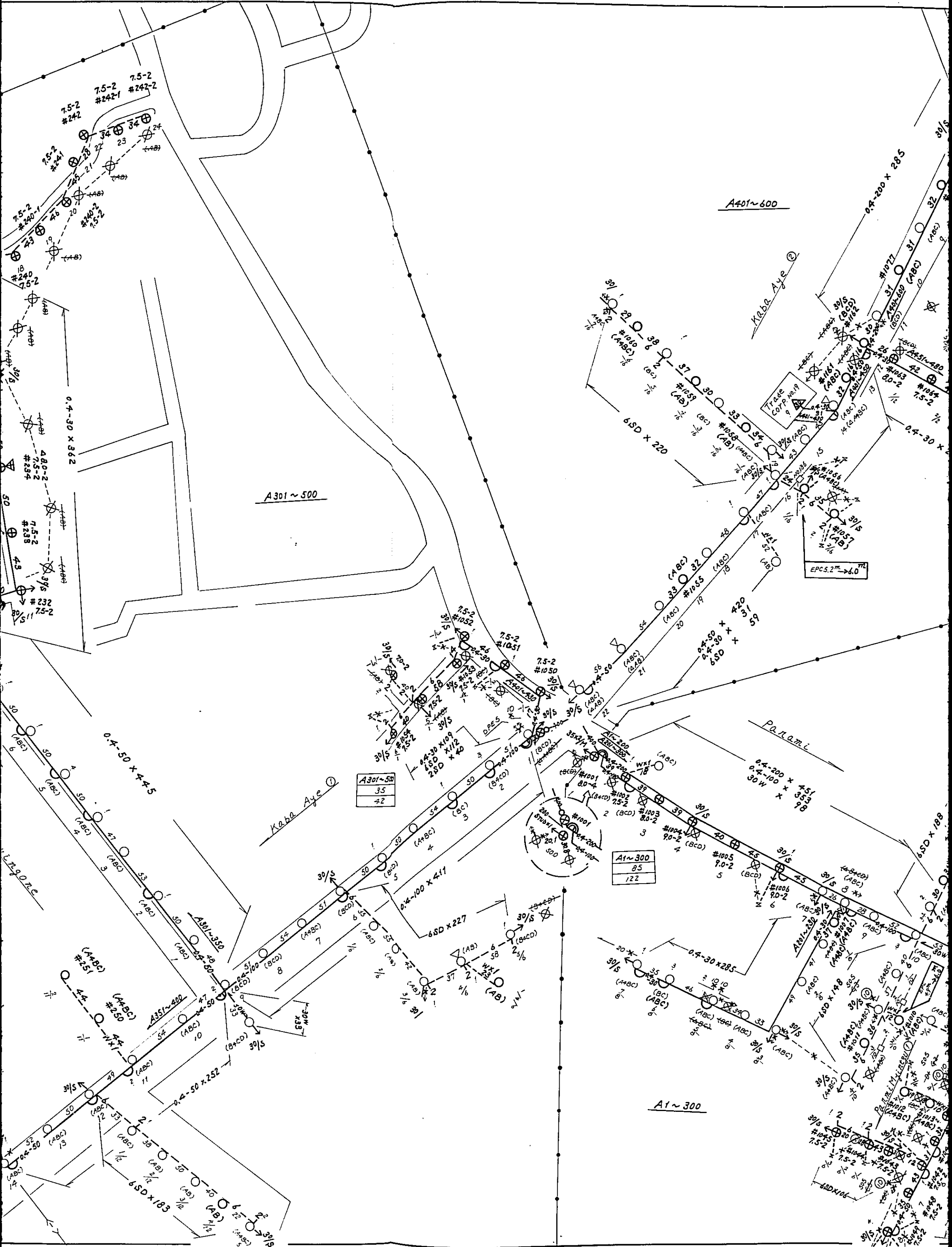

A401~600

A301~500

A301~500

35
42

A1~300

85
122

A1~300

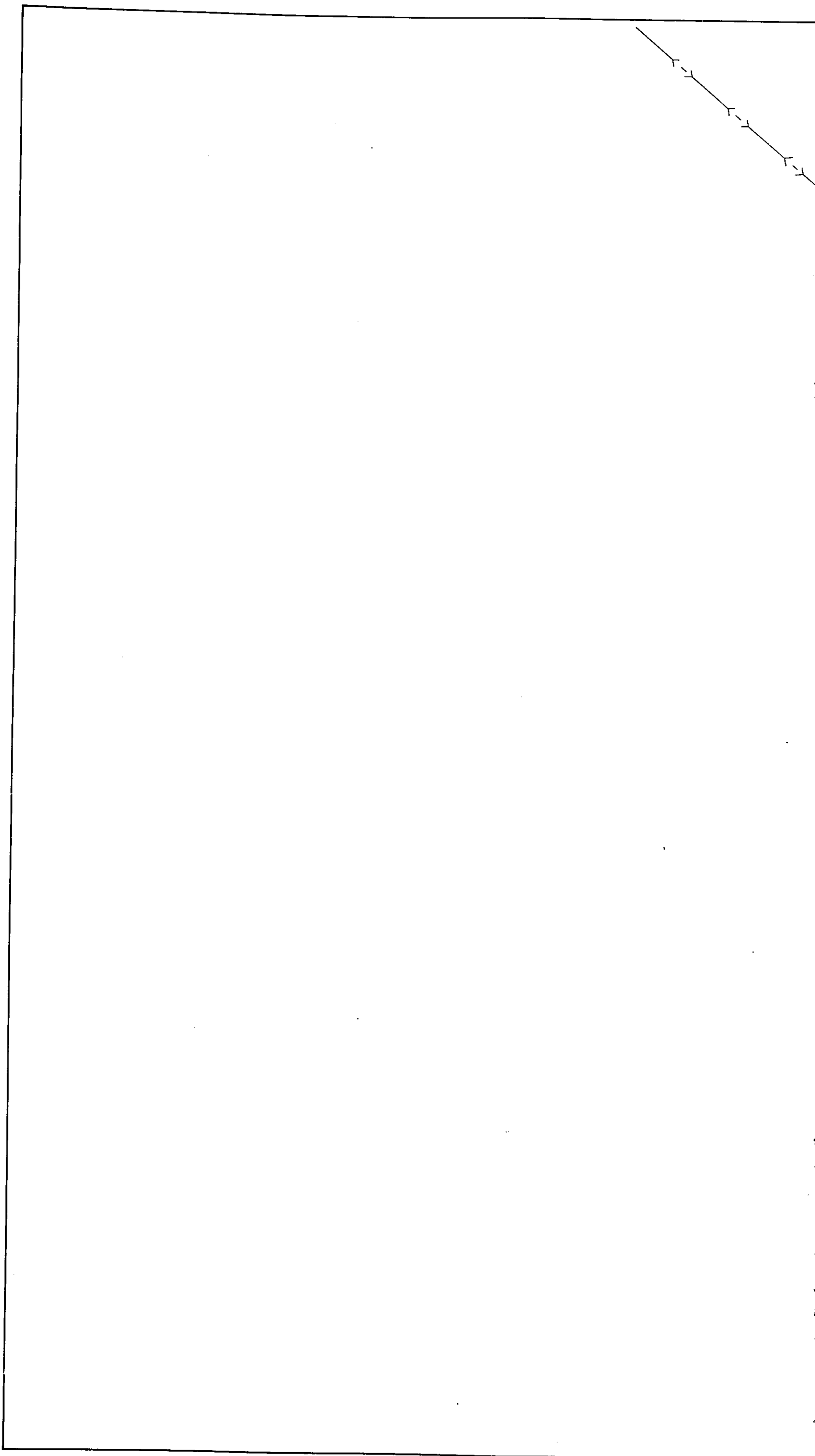

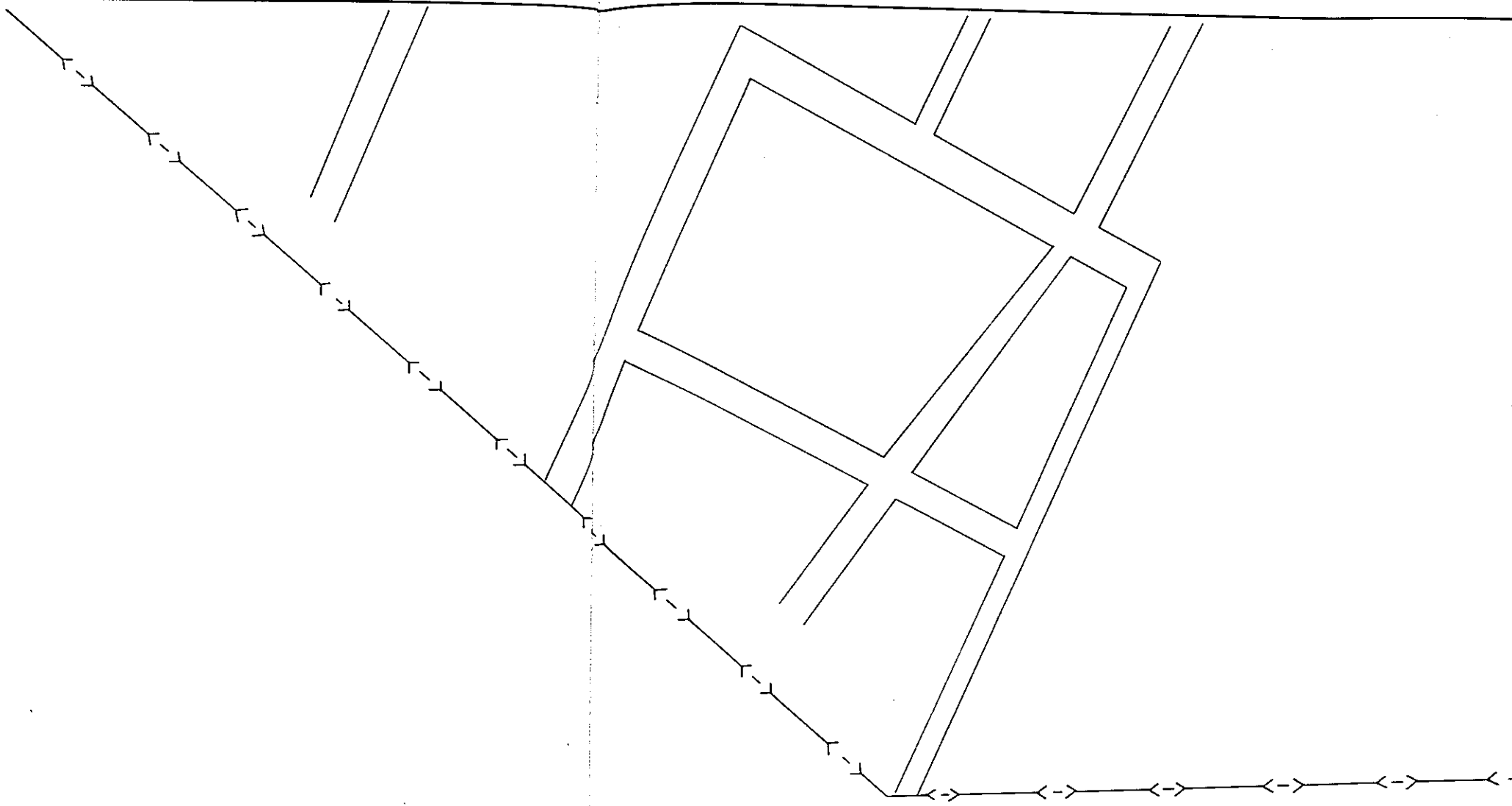

	12	19
	(13)	

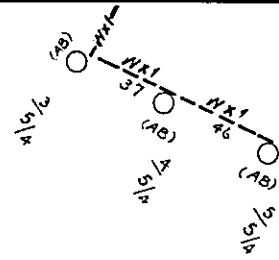

A1-300

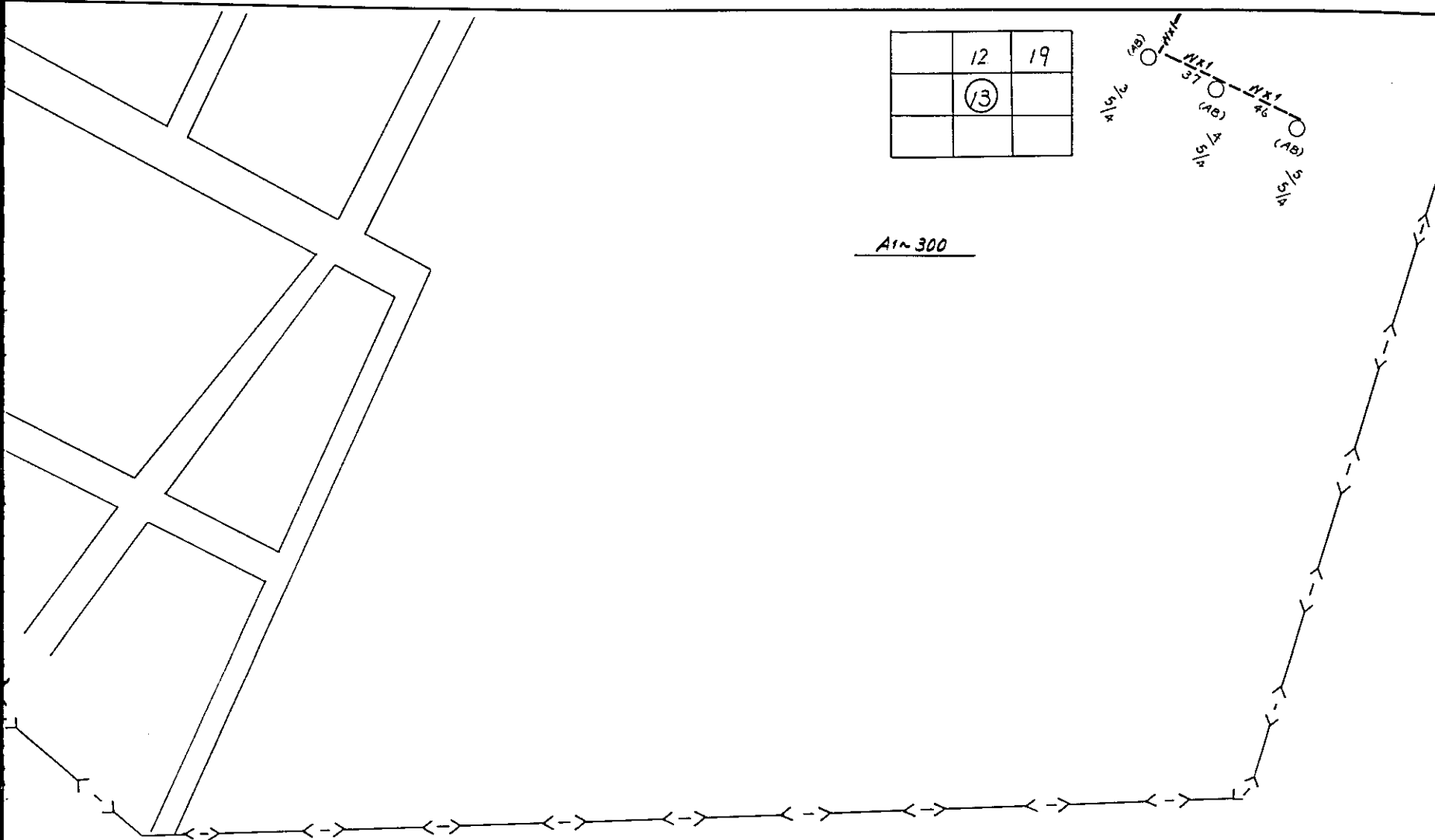

Exchange	Mayangon
Drawing	Subscriber Aerial Cable Plan
Drawing No.	III. 9. 13/27

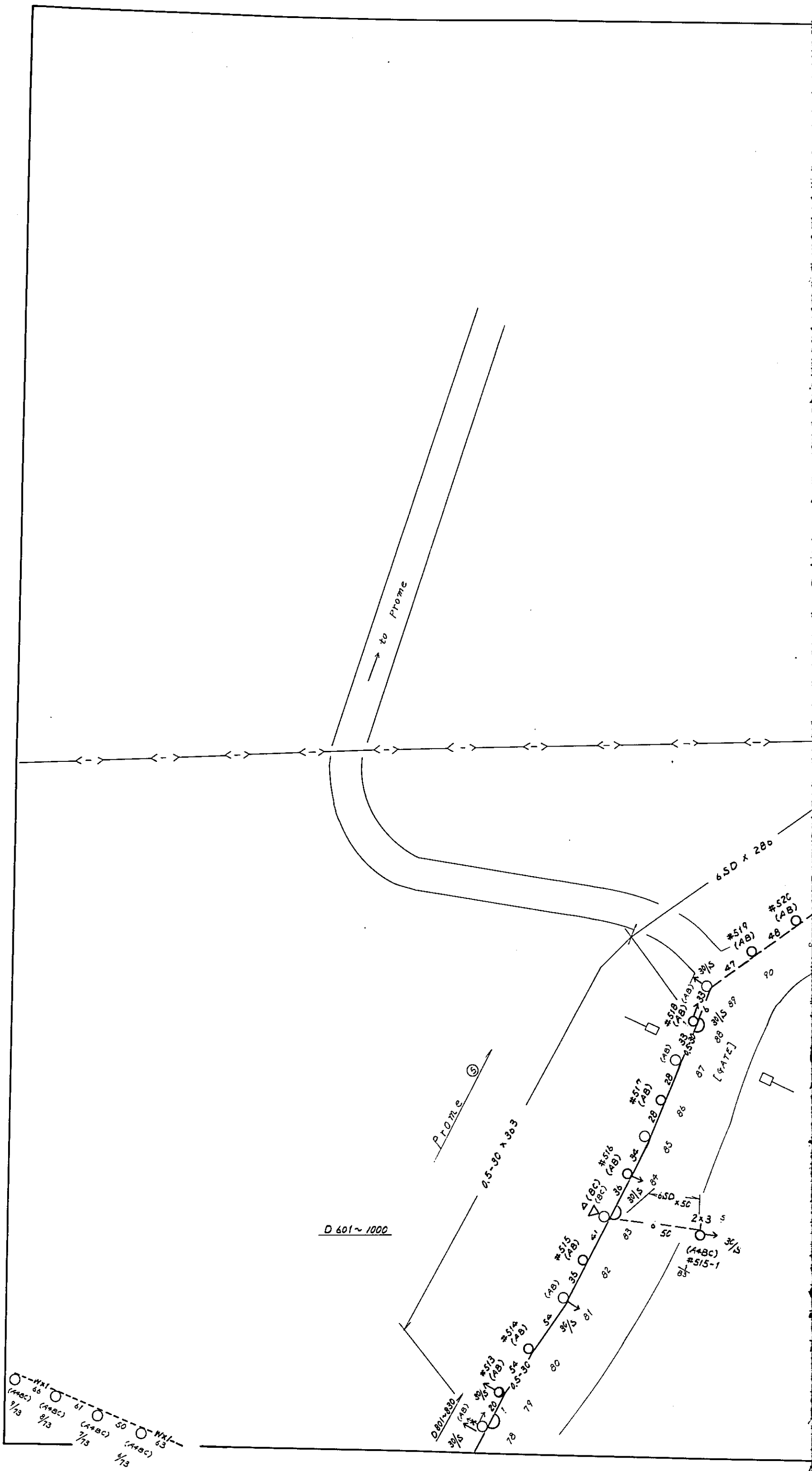



	14	20
8	15	21

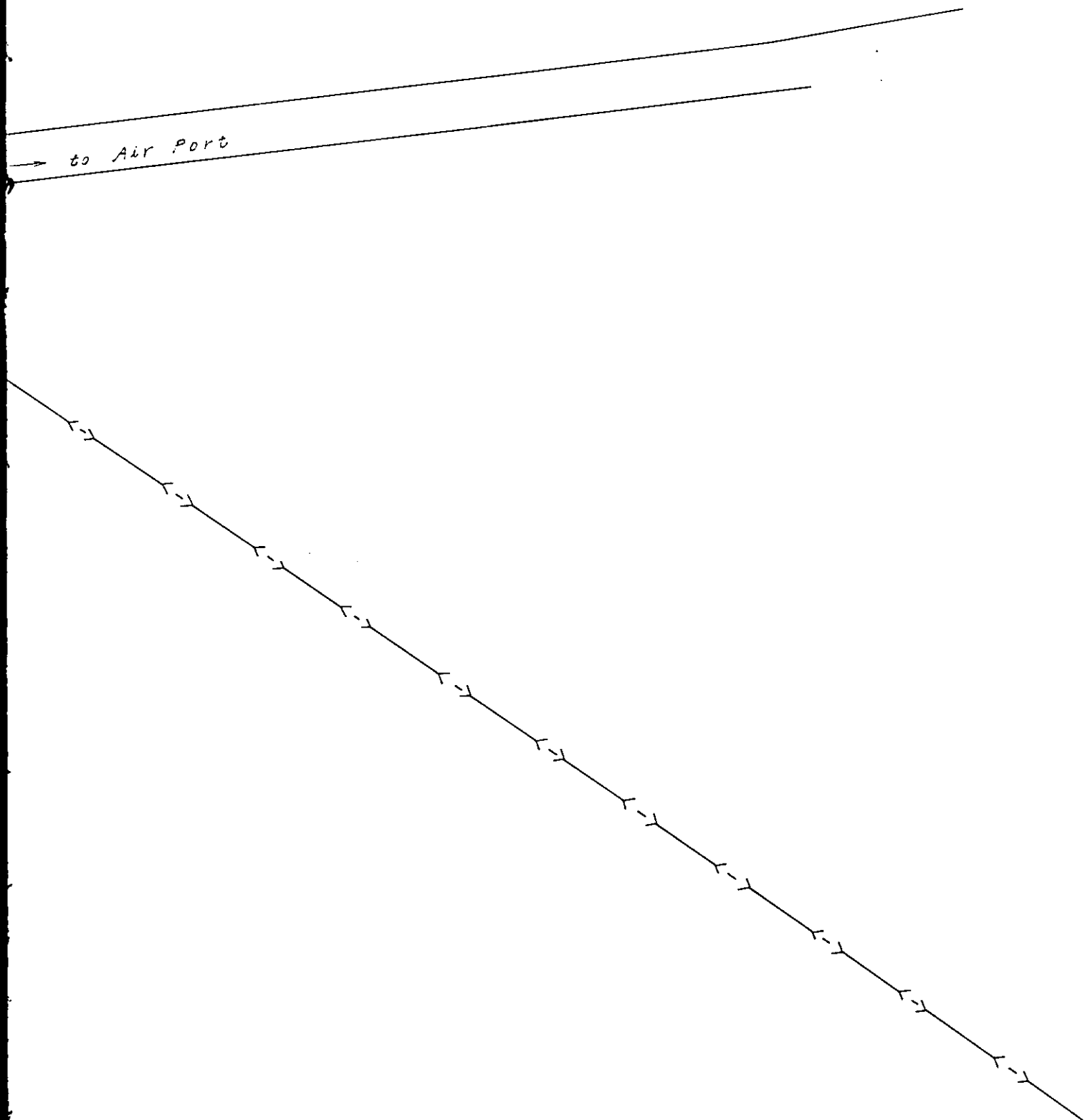

Exchange	Mayangon
Drawing	Subscriber Aerial Cable Plan
Drawing No.	III. 9. 14/27

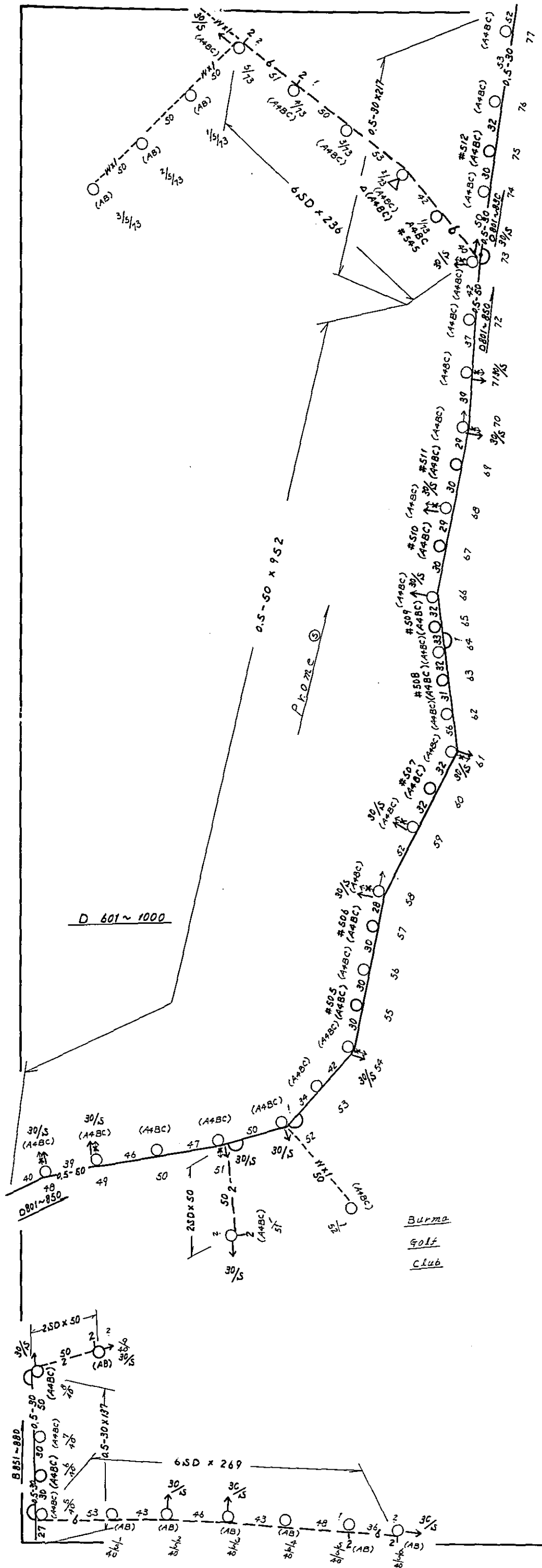

Burma
Golf
Club

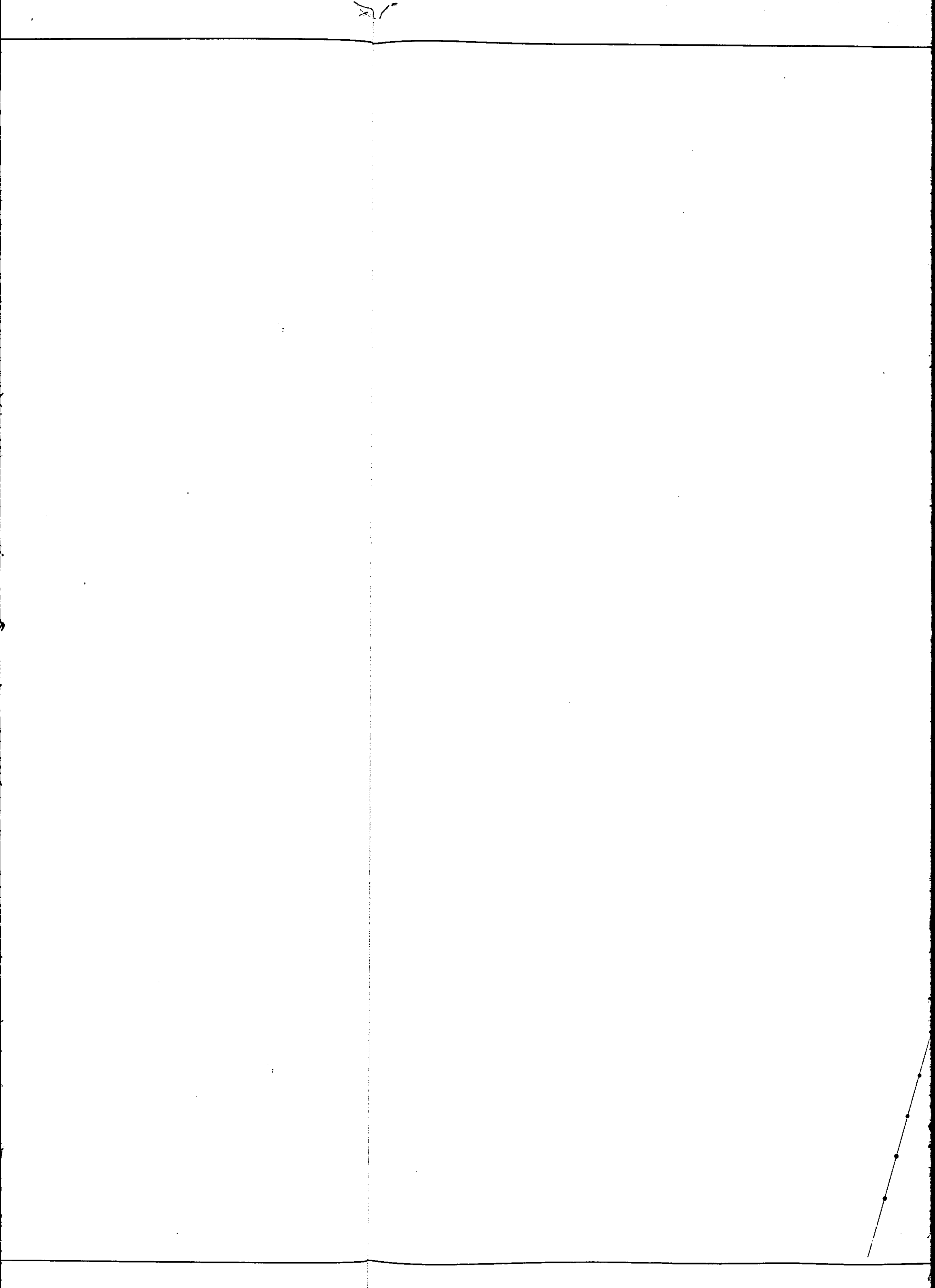

	14	20
8	(15)	21
9	16	22

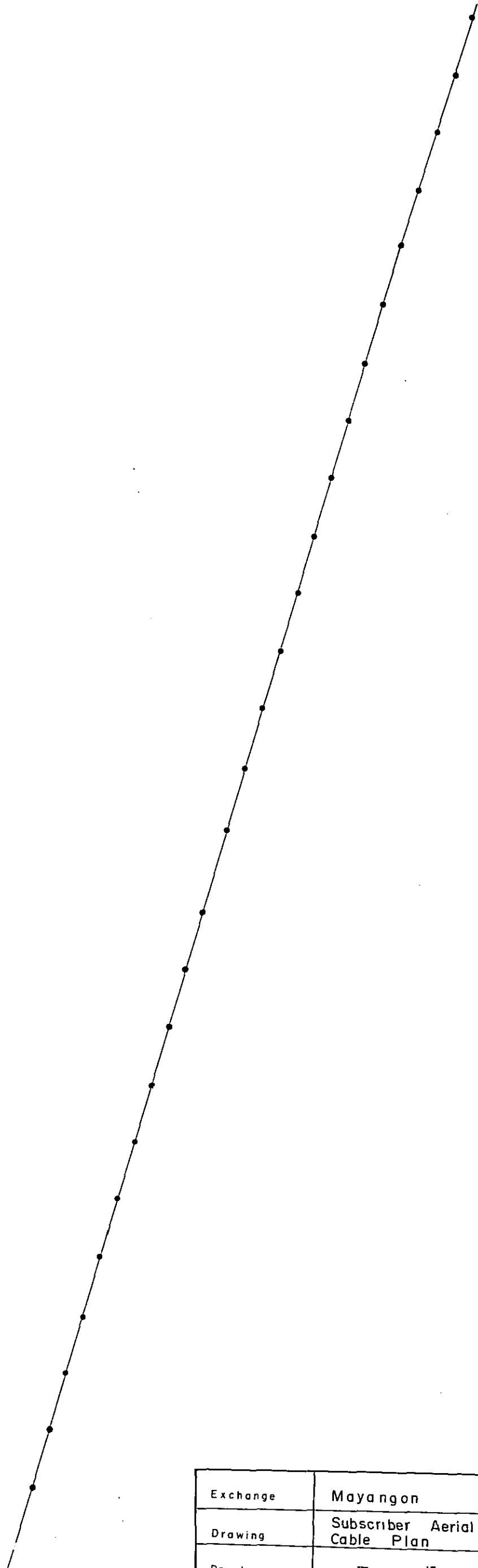

Exchange	Mayangon
Drawing	Subscriber Aerial Cable Plan
Drawing No	III. 9. 15/27

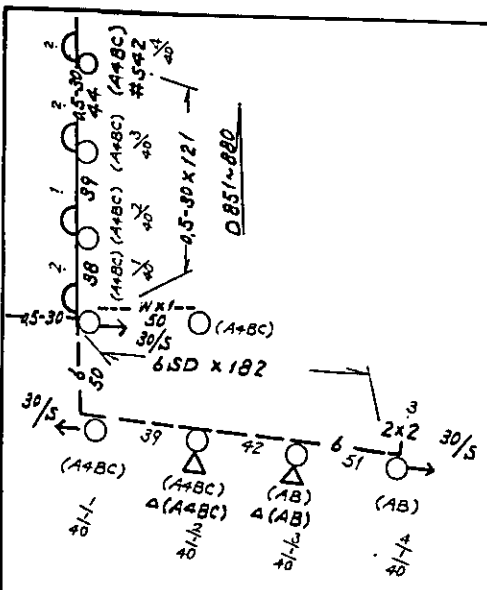

D 601~1000

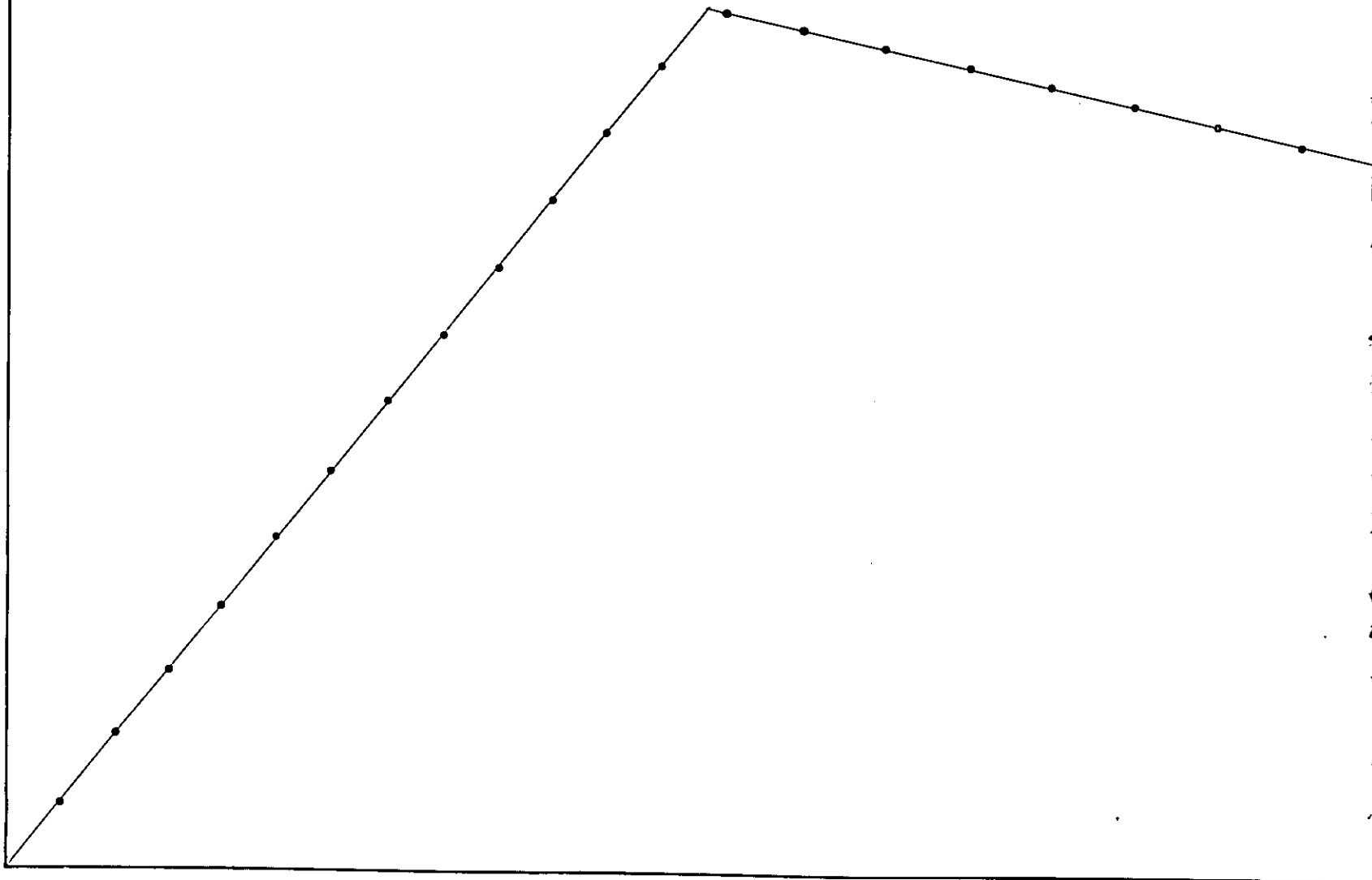
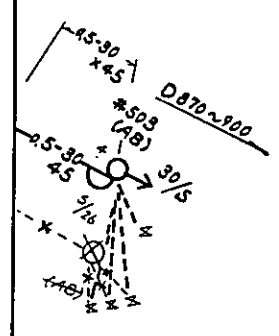

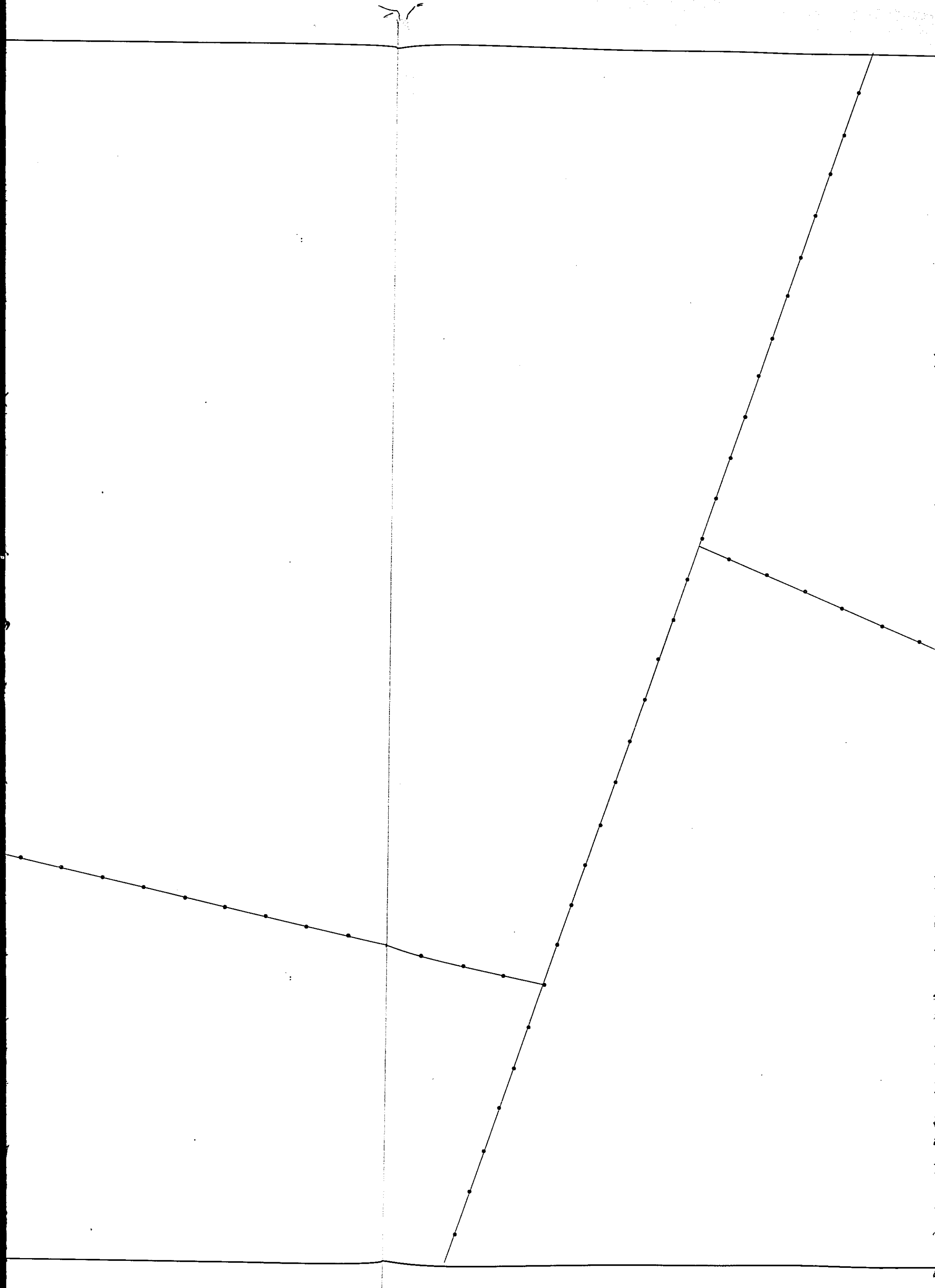

8	15	21
9	16	22
10	17	23

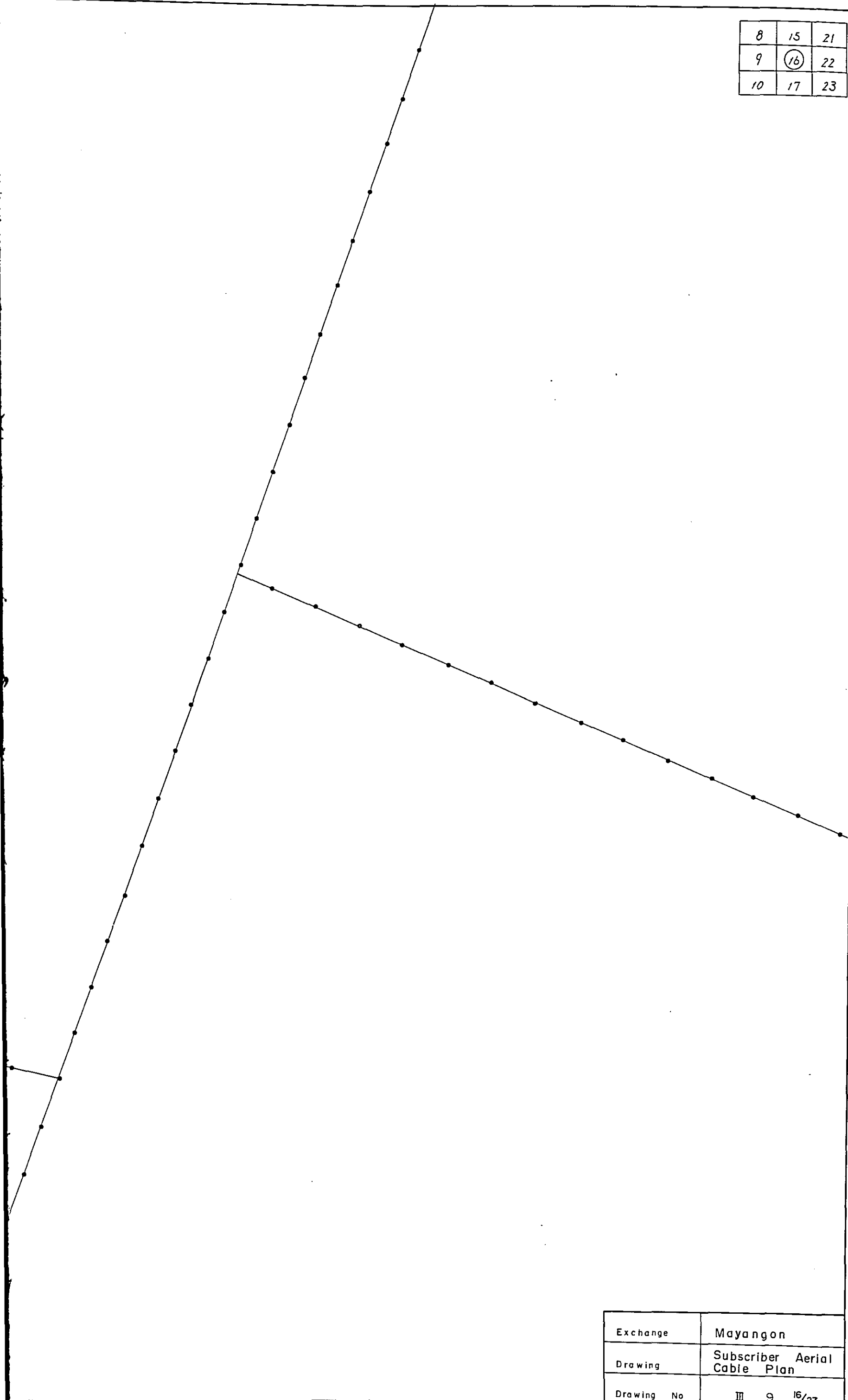

Exchange	Mayangon
Drawing	Subscriber Aerial Cable Plan
Drawing No	III. 9. 16/27

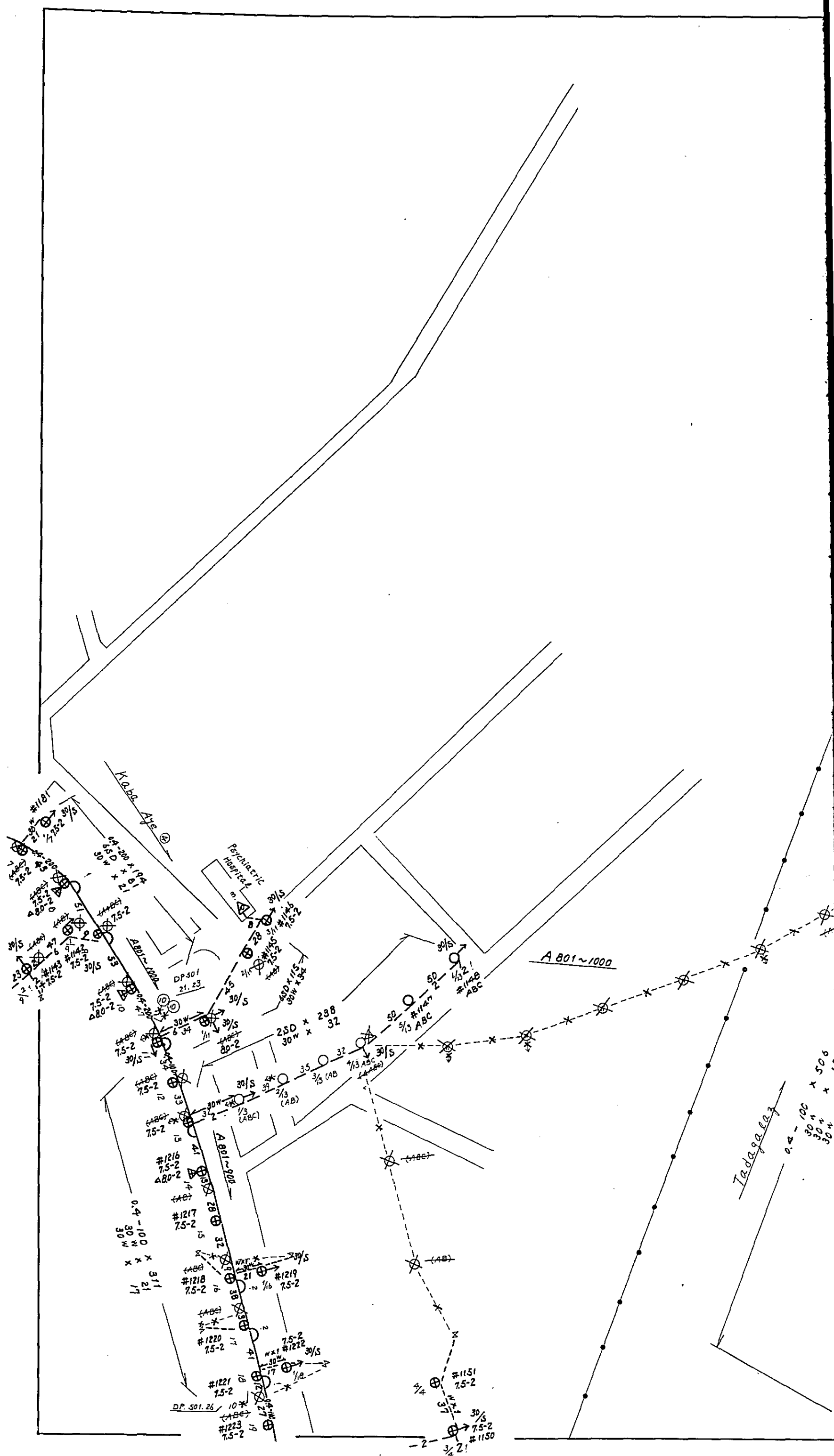

9	16	22
10	(17)	23
11	18	

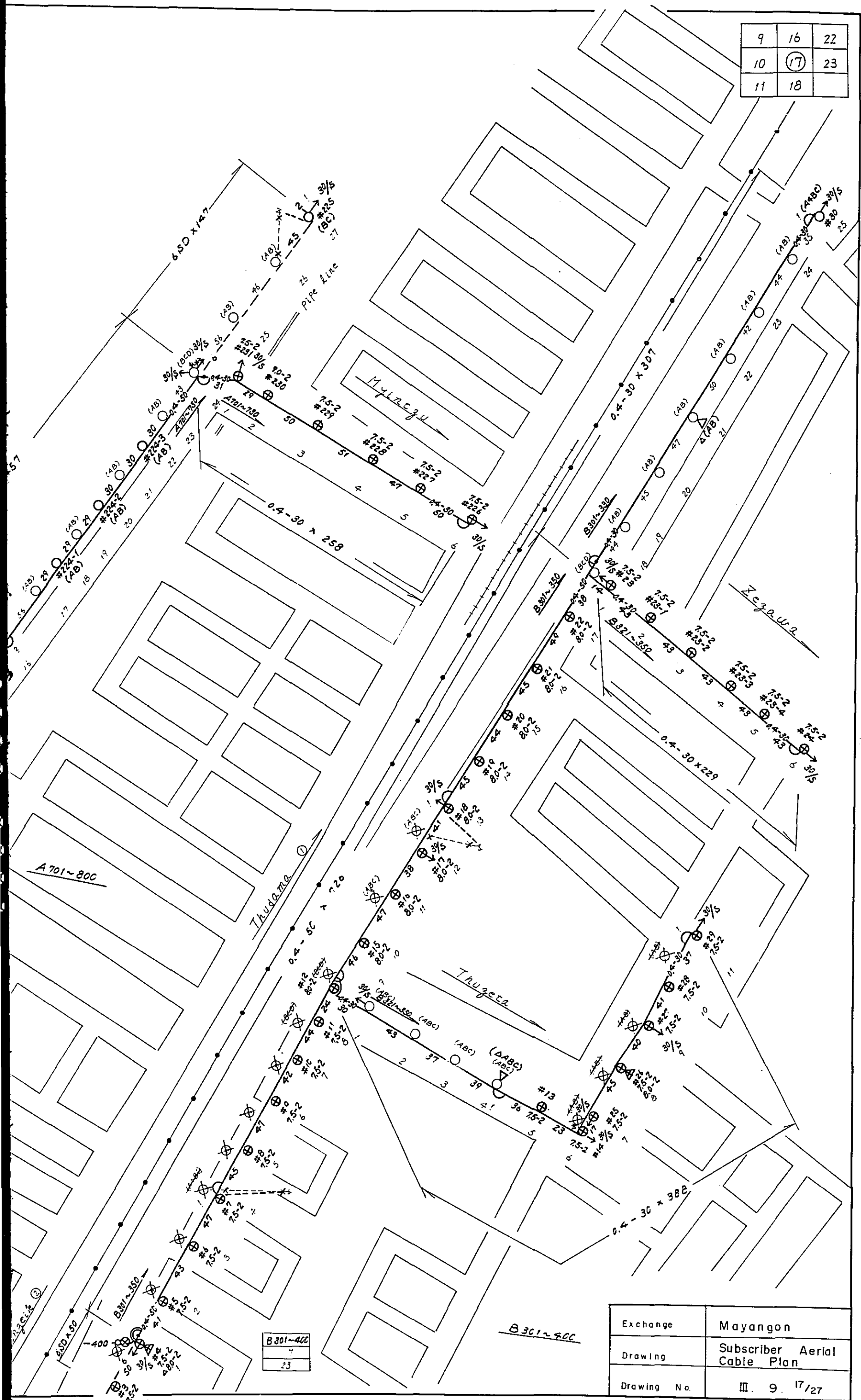

B 301-400	7
	23

B 301-400

Exchange	Mayangon
Drawing	Subscriber Aerial Cable Plan
Drawing No.	III. 9. 17/27

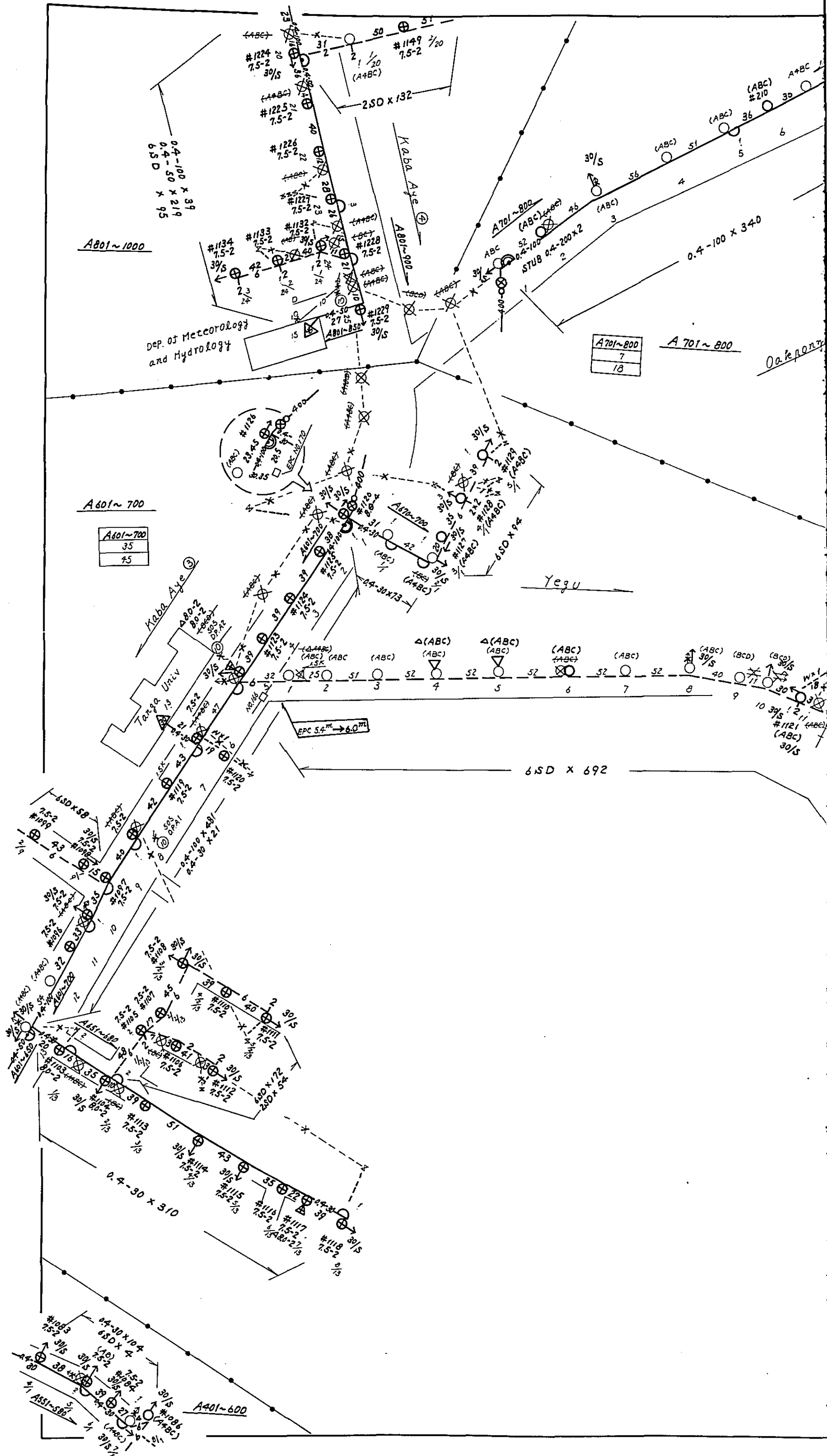

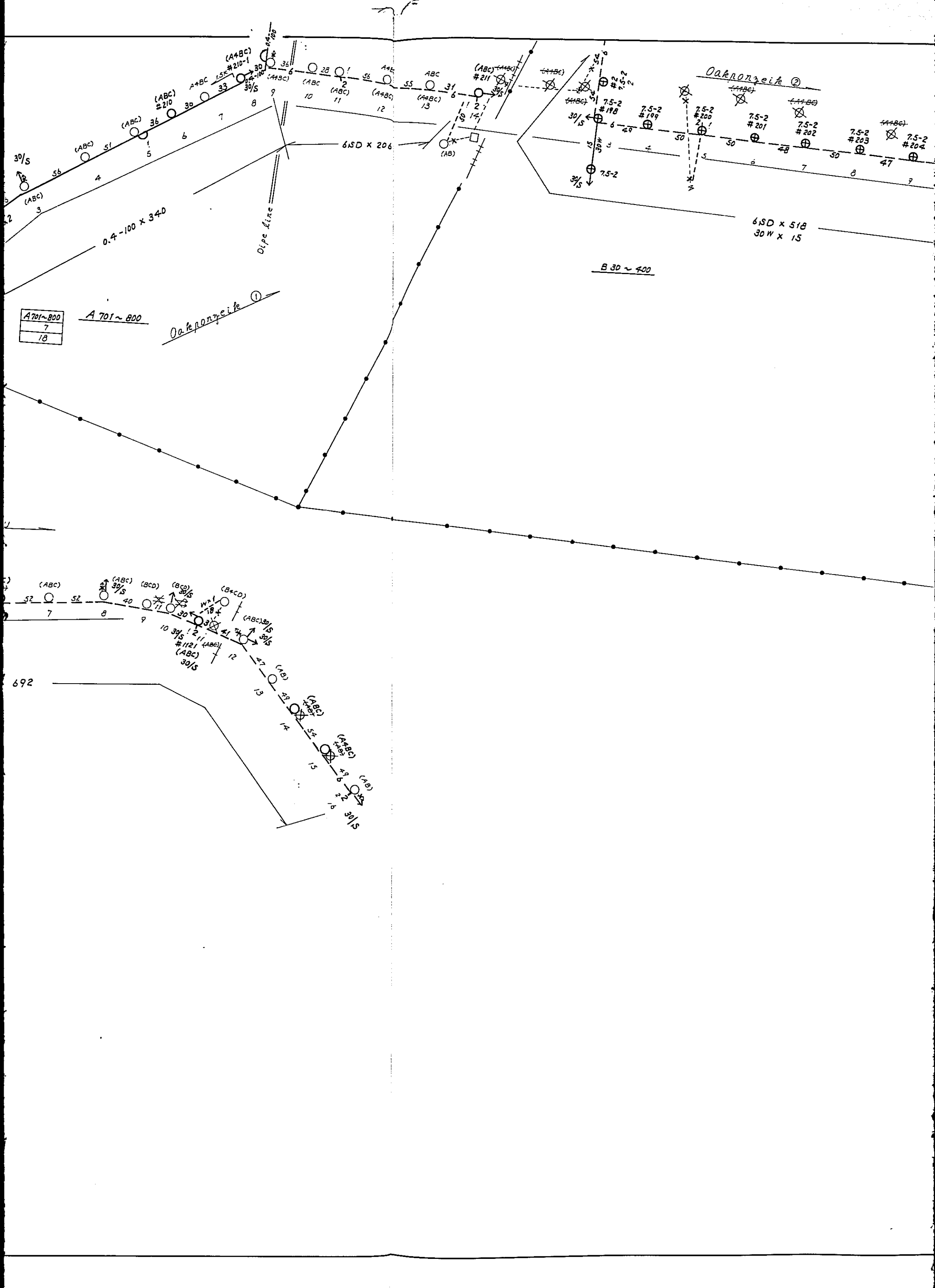

A 701~800
7
18

A 701~800

Oakronzeik ①

Oakronzeik ②

Dipe line

0.4-100 x 340

6SD x 206

6SD x 518
30 W x 15

B 30 ~ 400

692

10	17	
11	18	
12	19	

Oakronzeit ②

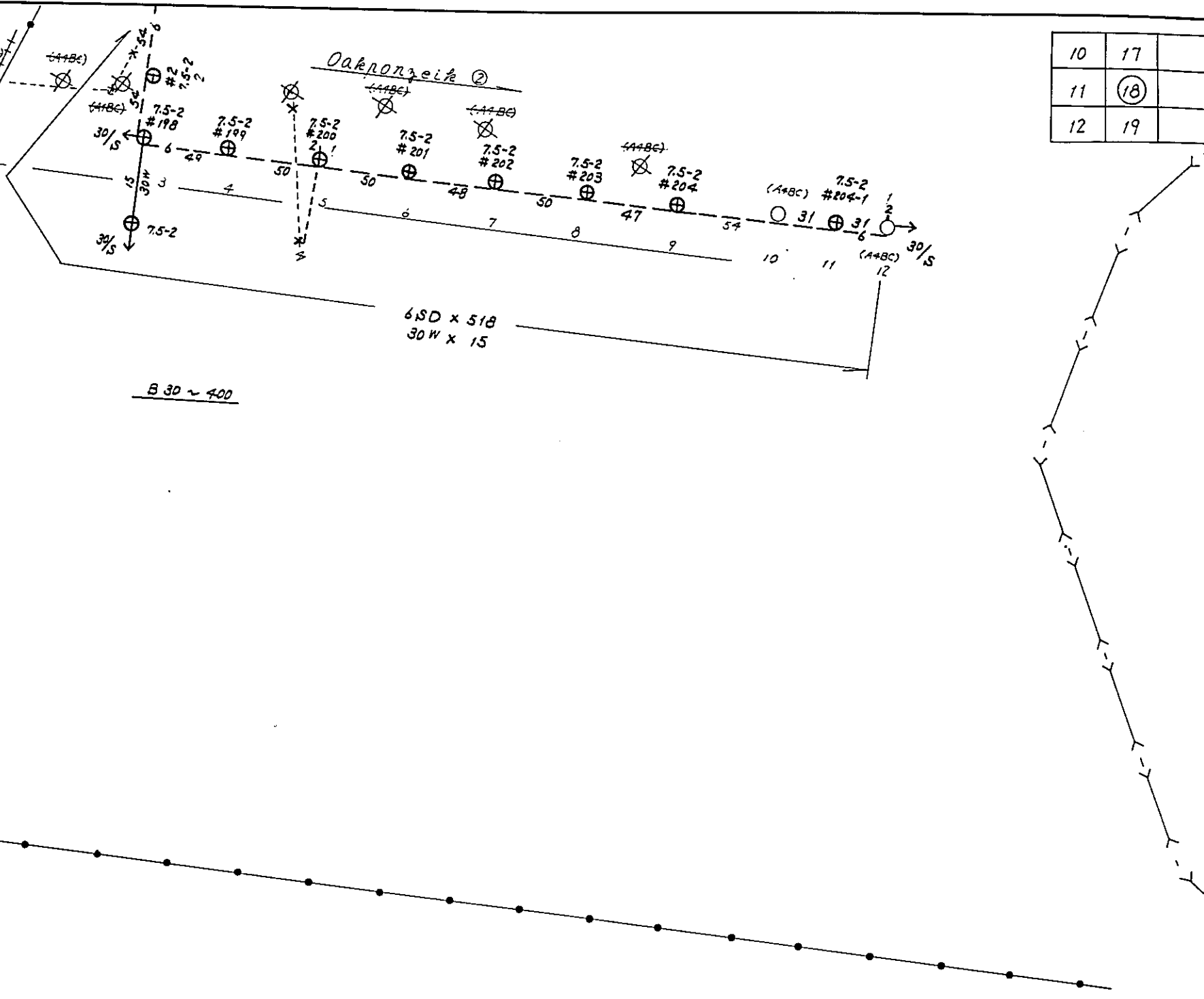

B 30 ~ 400

6SD x 518
30W x 15

Exchange	Mayangon
Drawing	Subscriber Aerial Cable Plan
Drawing No.	III. 9. 18/27

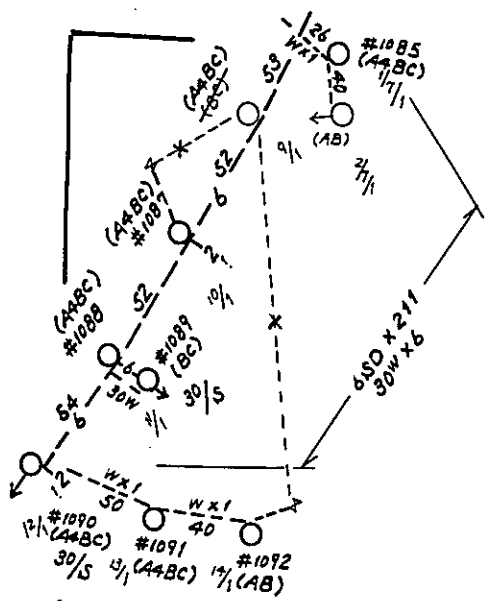

A 401 ~ 600

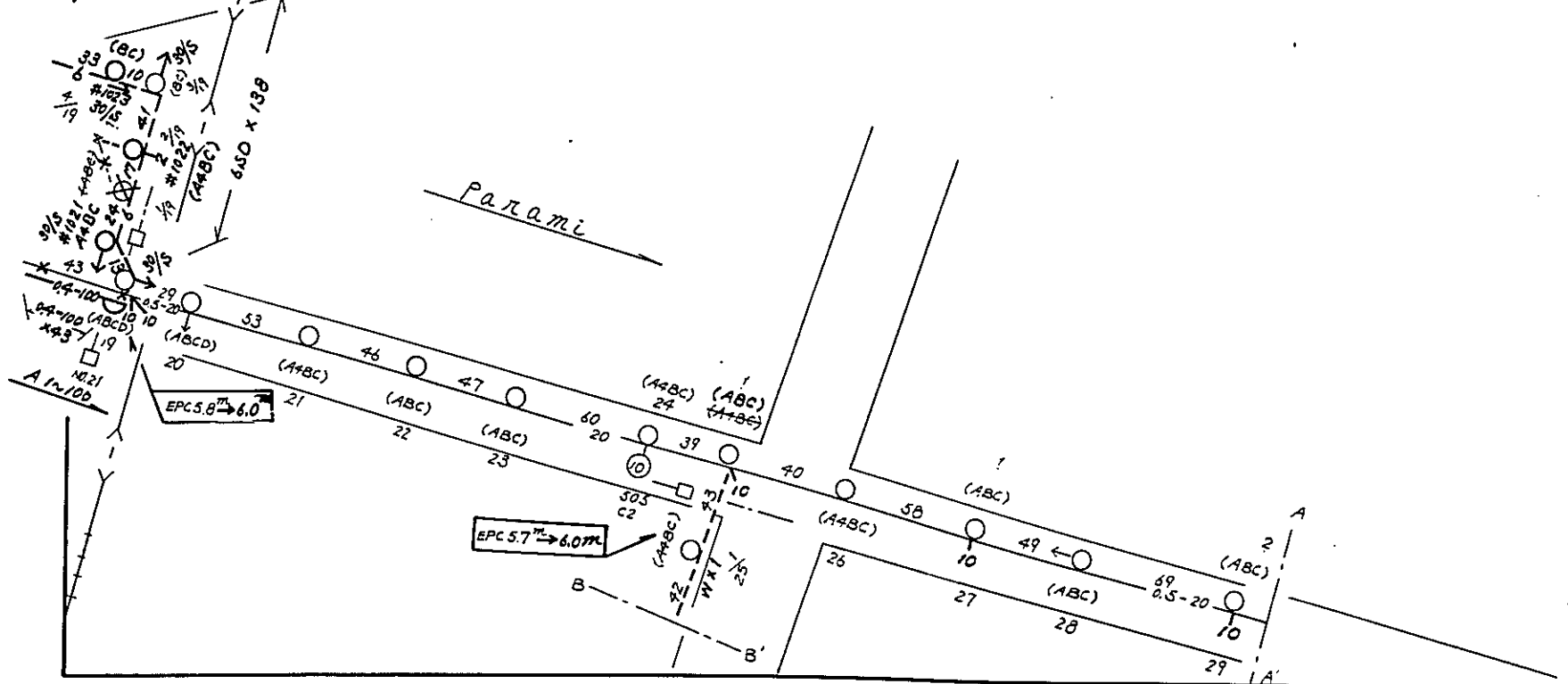
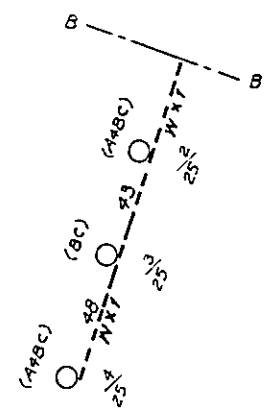
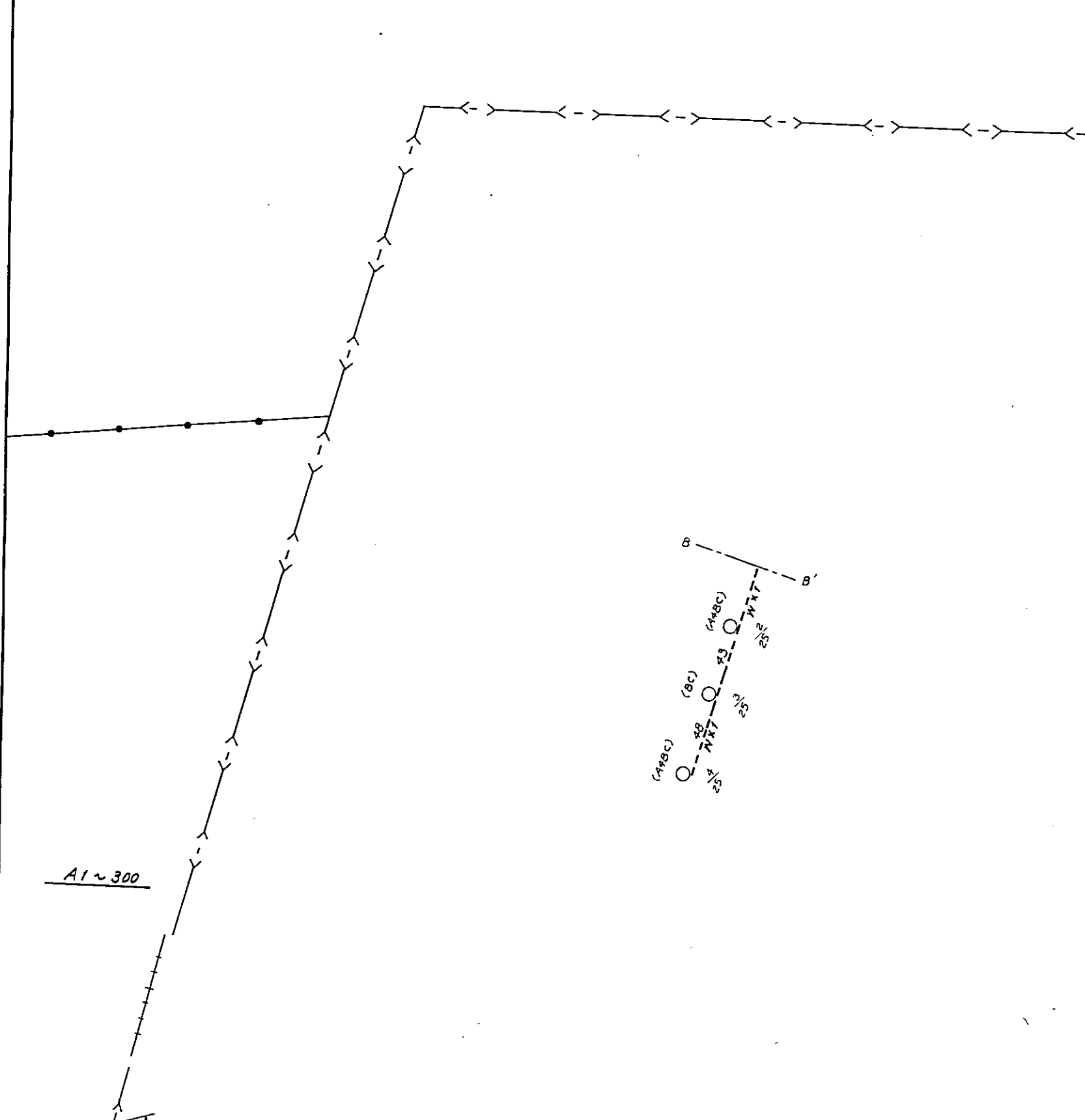

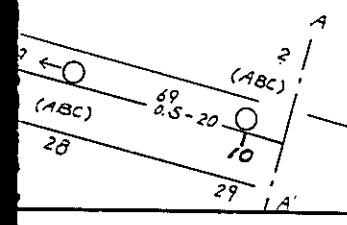
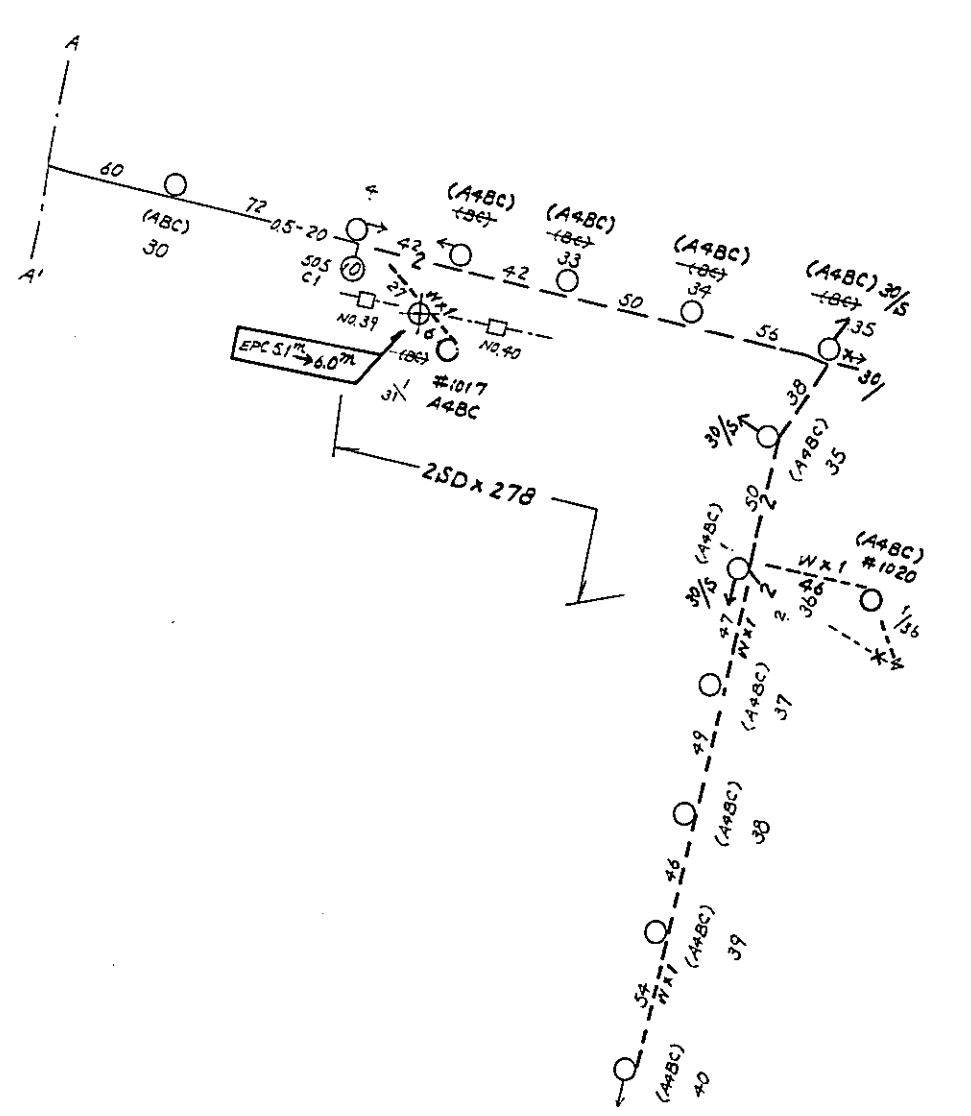
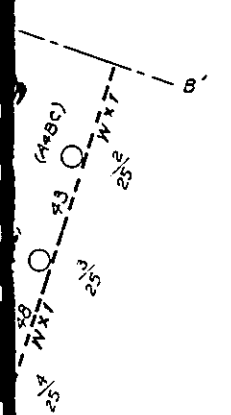

11	18	
12	(19)	
13		

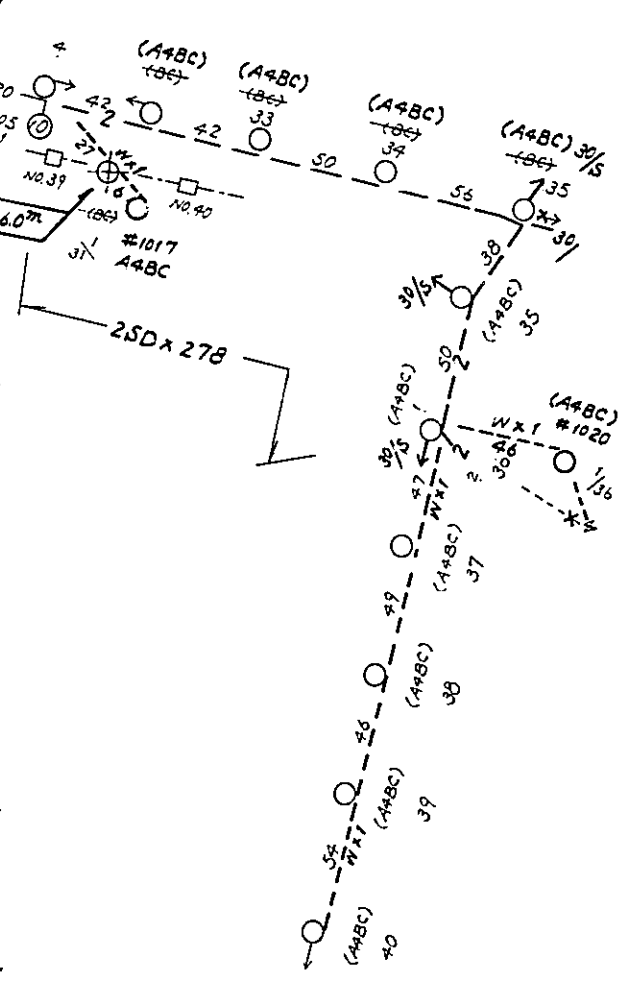
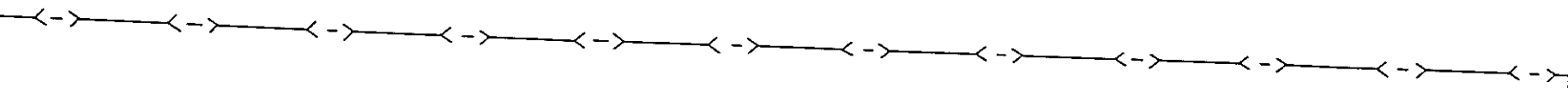

Exchange	Mayangon
Drawing	Subscriber Aerial Cable Plan
Drawing No.	III . 9 . 19 / 27

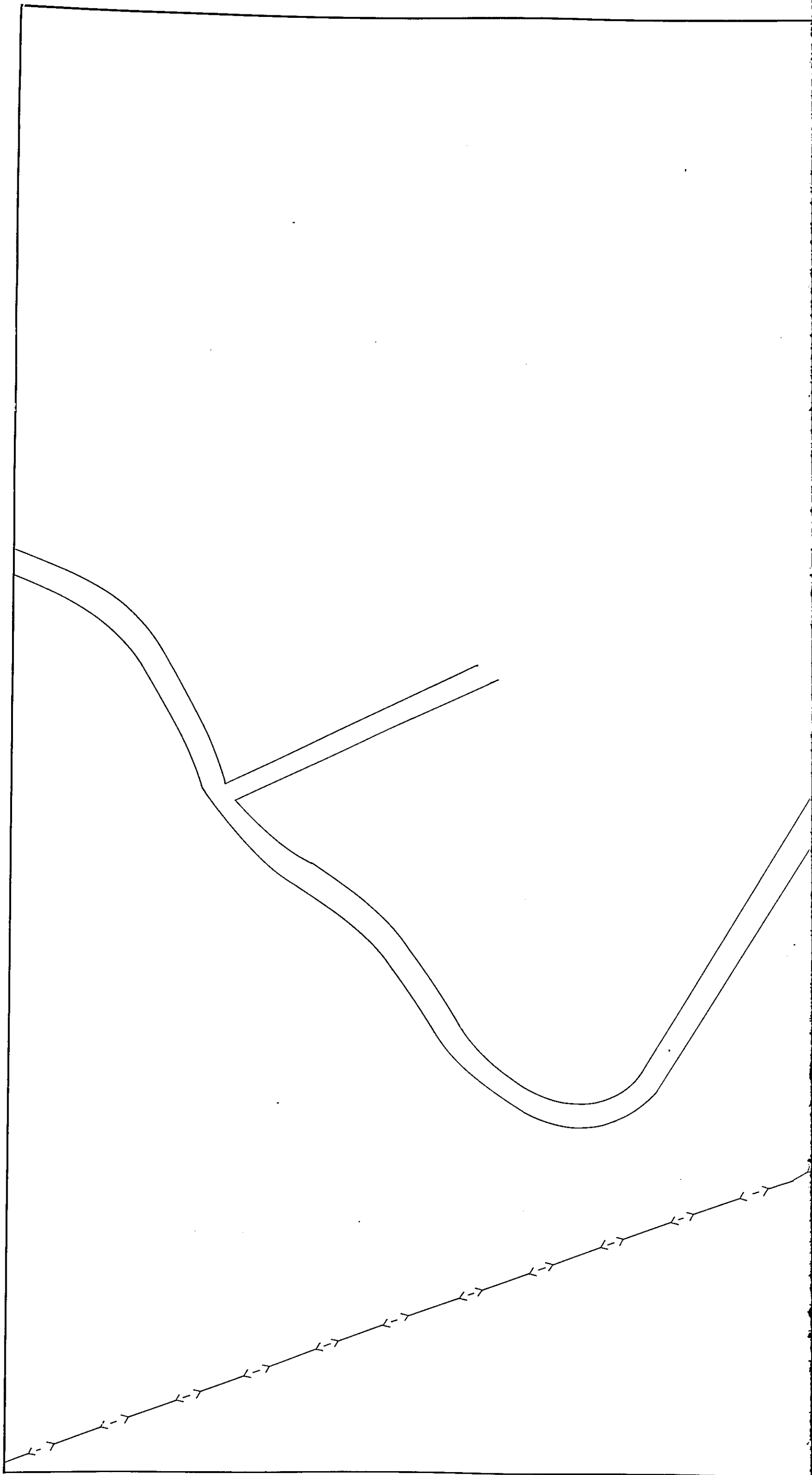

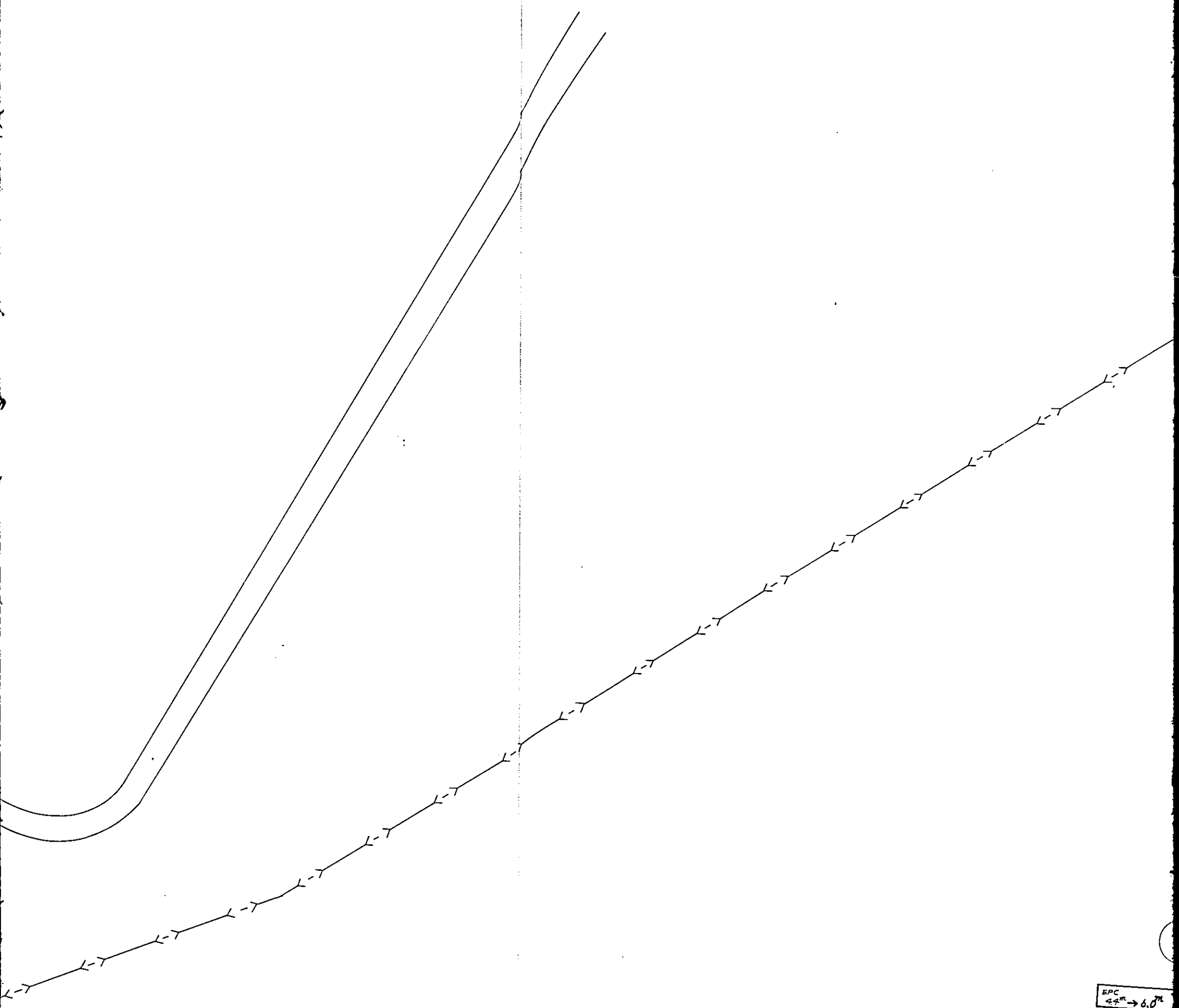

EPC
4.4m → 6.0m

Exchange	Mayangon
Drawing	Subscriber Aerial Cable Plan
Drawing No	III . 9 20/27

14	20	24
15	21	25

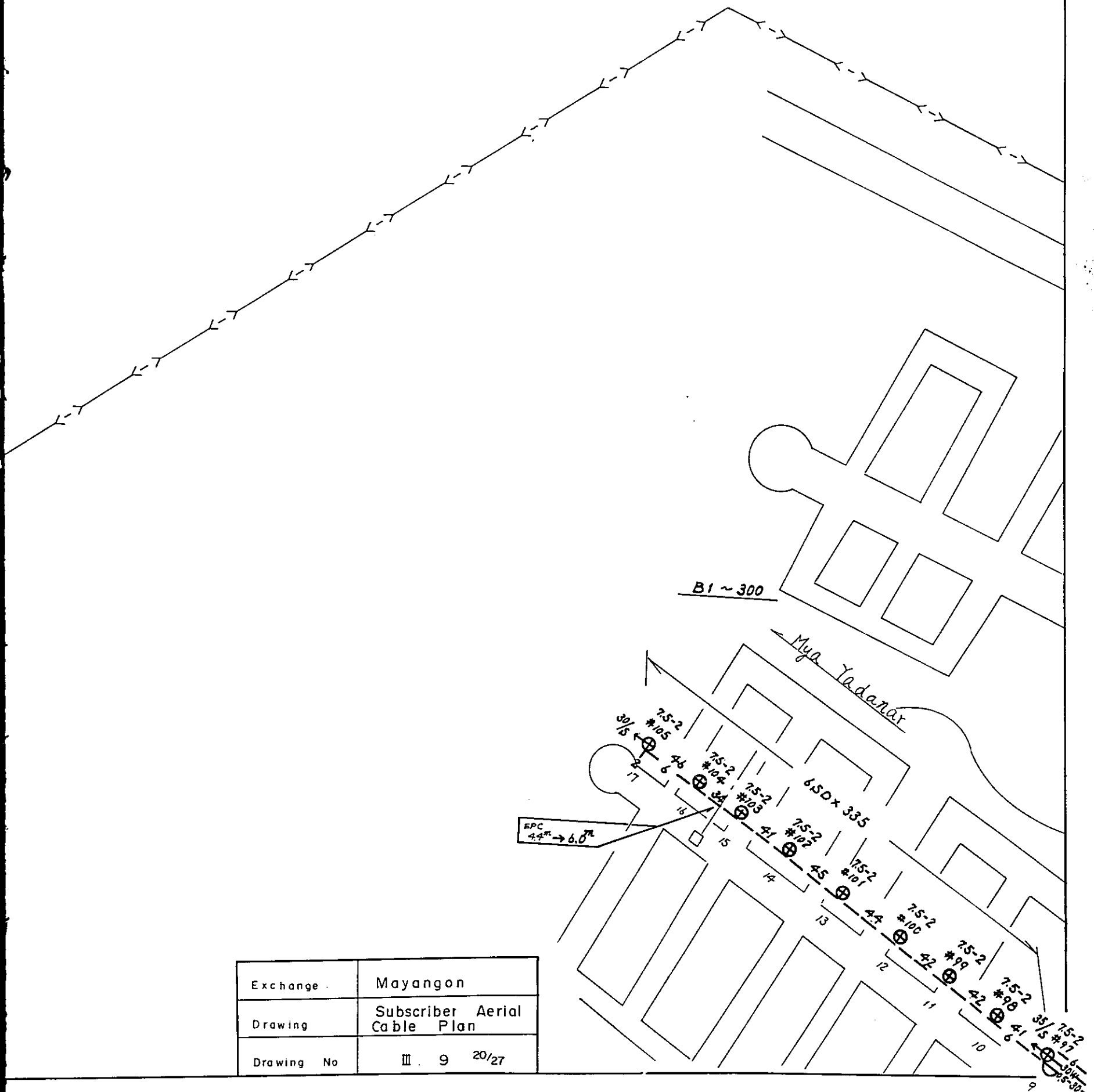

Exchange	Mayangon
Drawing	Subscriber Aerial Cable Plan
Drawing No	III . 9 20/27

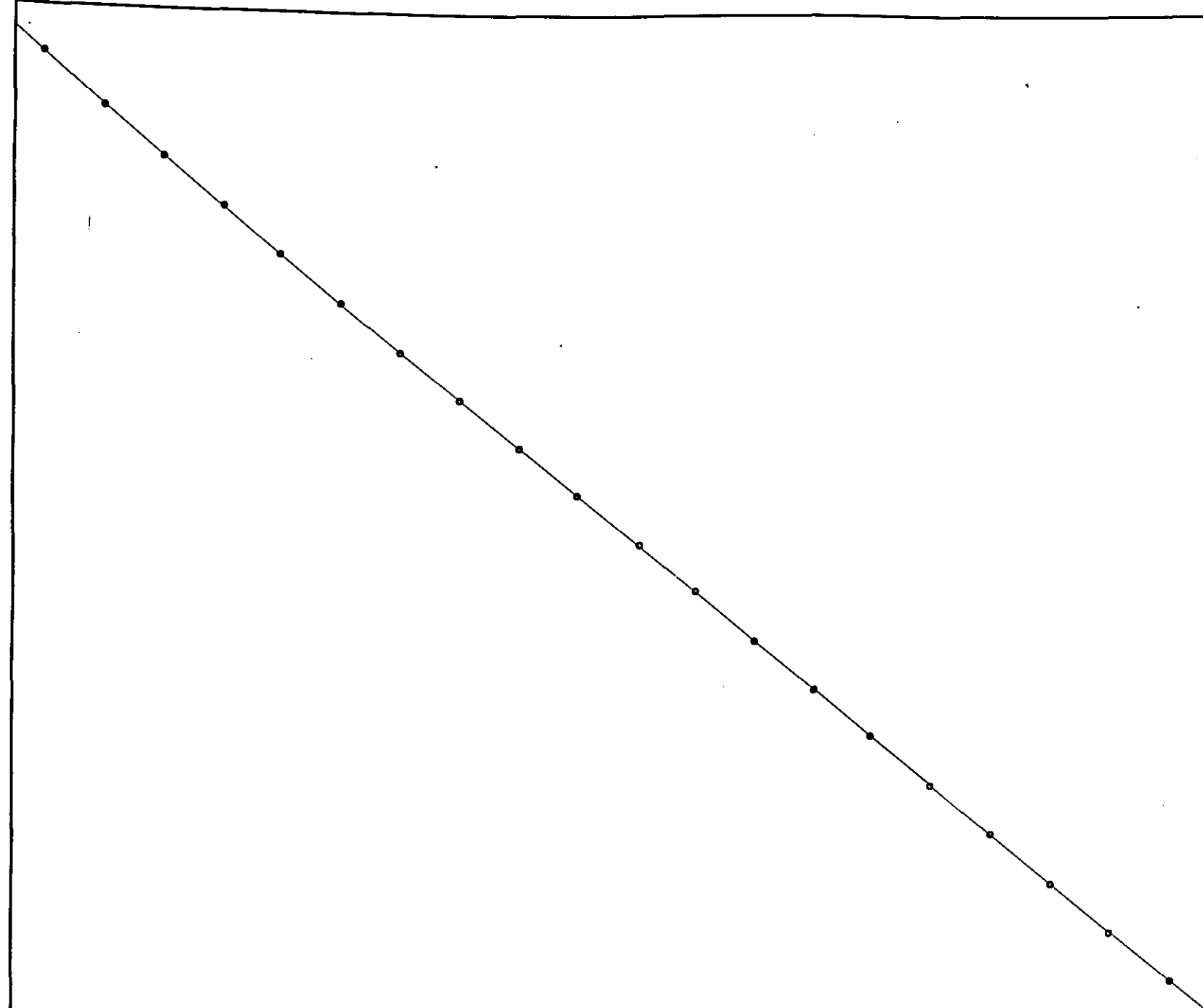

B 301 ~ 350

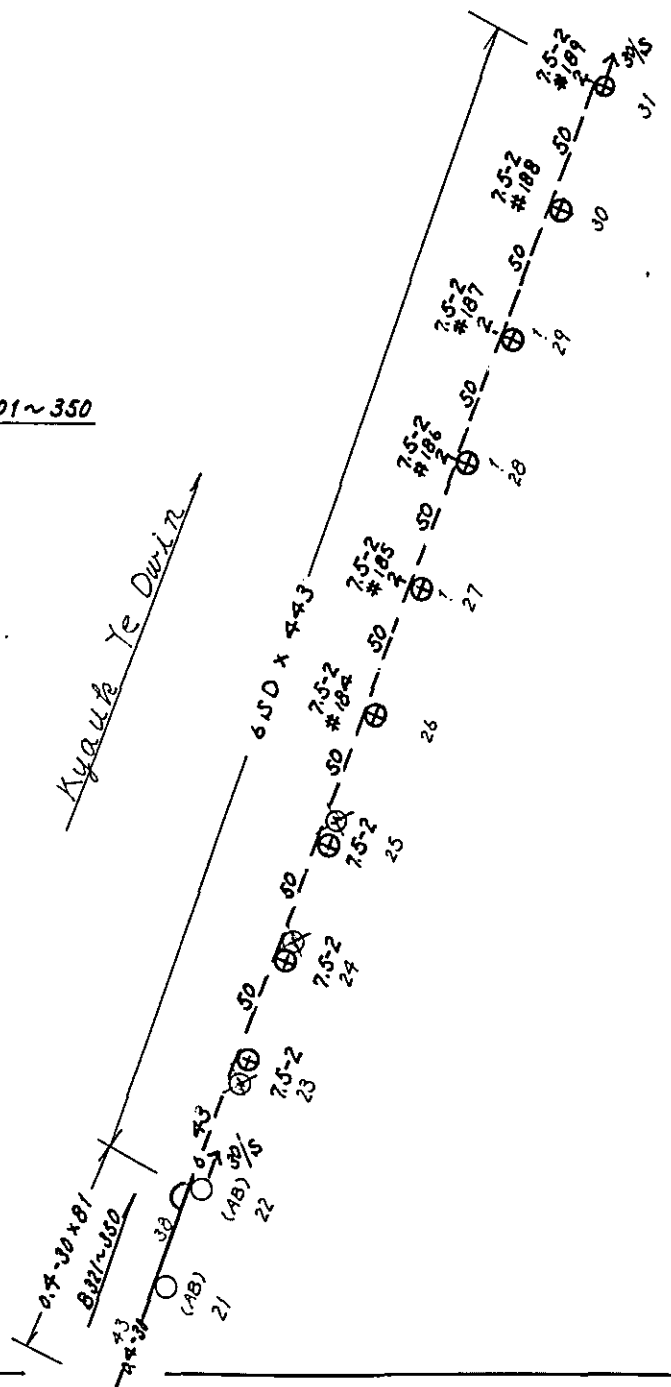

Exchange	Mayangon
Drawing	Subscriber Aerial Cable Plan
Drawing No.	III. 9. 21/27

14	20	24
15	(21)	25
16	22	26

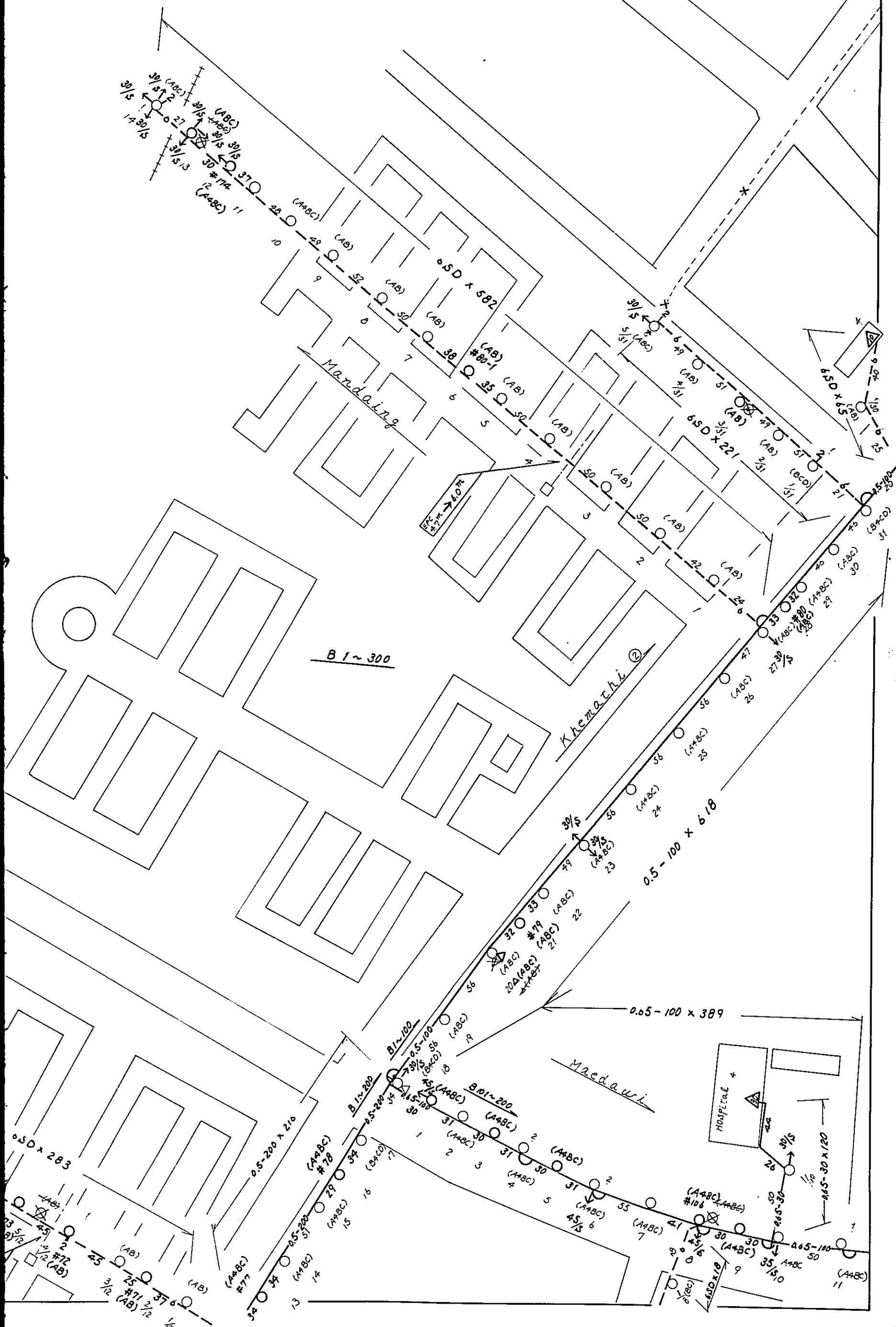

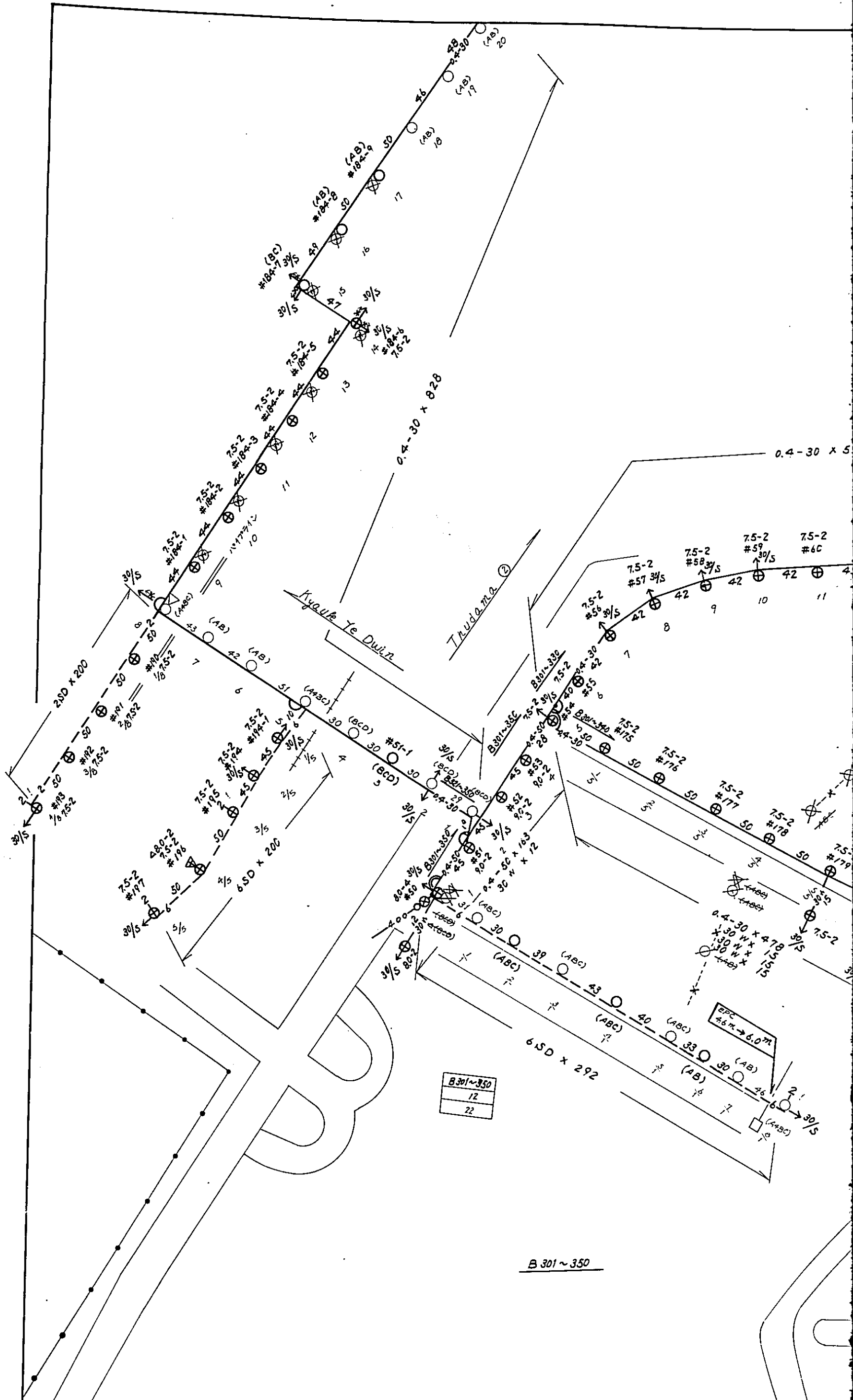

Exchange	Mayangon
Drawing	Subscriber Aerial Cable Plan
Drawing No.	III. 9. 22/27

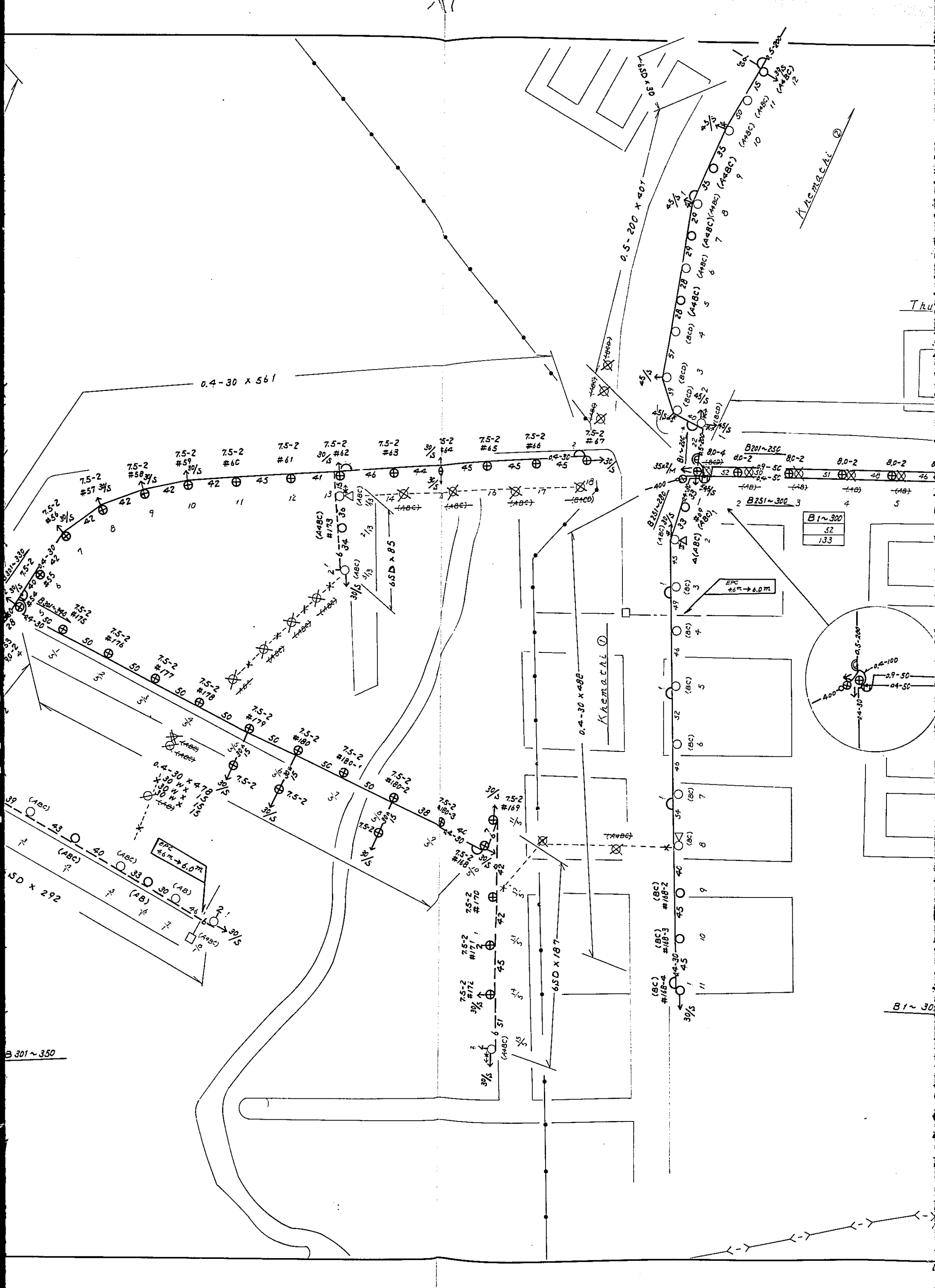

0.4-30 x 561

0.5-200 x 401

KREMACKI

B201~250
 20-2
 29-50
 30-50
 31
 32
 33
 34
 35
 36
 37
 38
 39
 40
 41
 42
 43
 44
 45
 46
 47
 48
 49
 50
 51
 52
 53
 54
 55
 56
 57
 58
 59
 60
 61
 62
 63
 64
 65
 66
 67
 68
 69
 70
 71
 72
 73
 74
 75
 76
 77
 78
 79
 80
 81
 82
 83
 84
 85
 86
 87
 88
 89
 90
 91
 92
 93
 94
 95
 96
 97
 98
 99
 100

B 1 ~ 300
 52
 133

EPC
 4.5m -> 6.0m

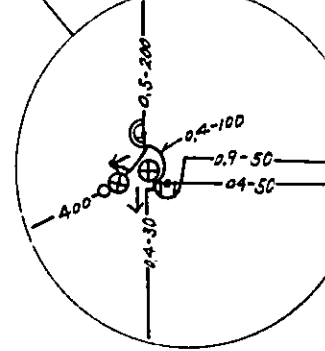

B 301 ~ 350

B 1 ~ 300

15	21	25
16	22	26
17	23	

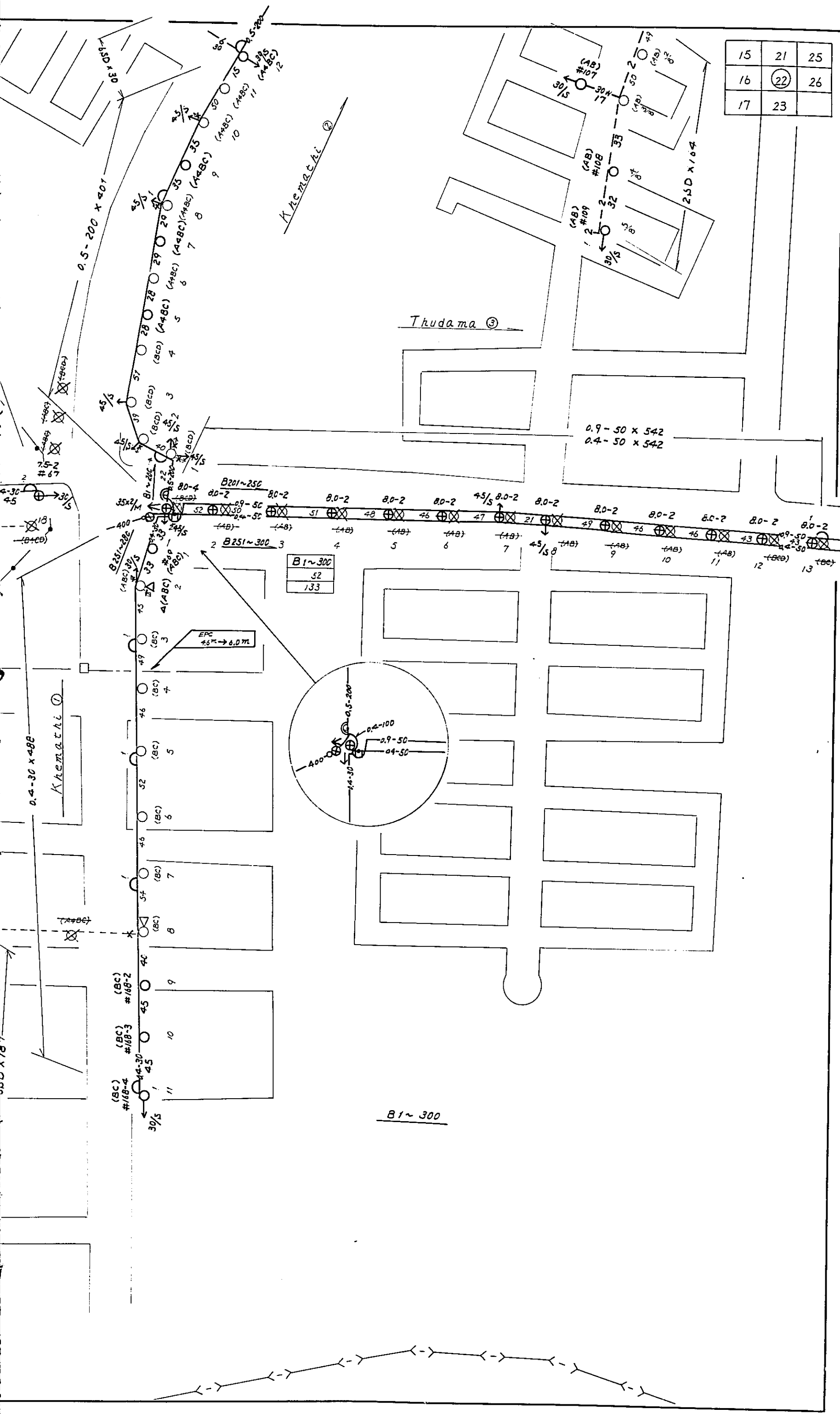

B1~300
52
133

B1~300

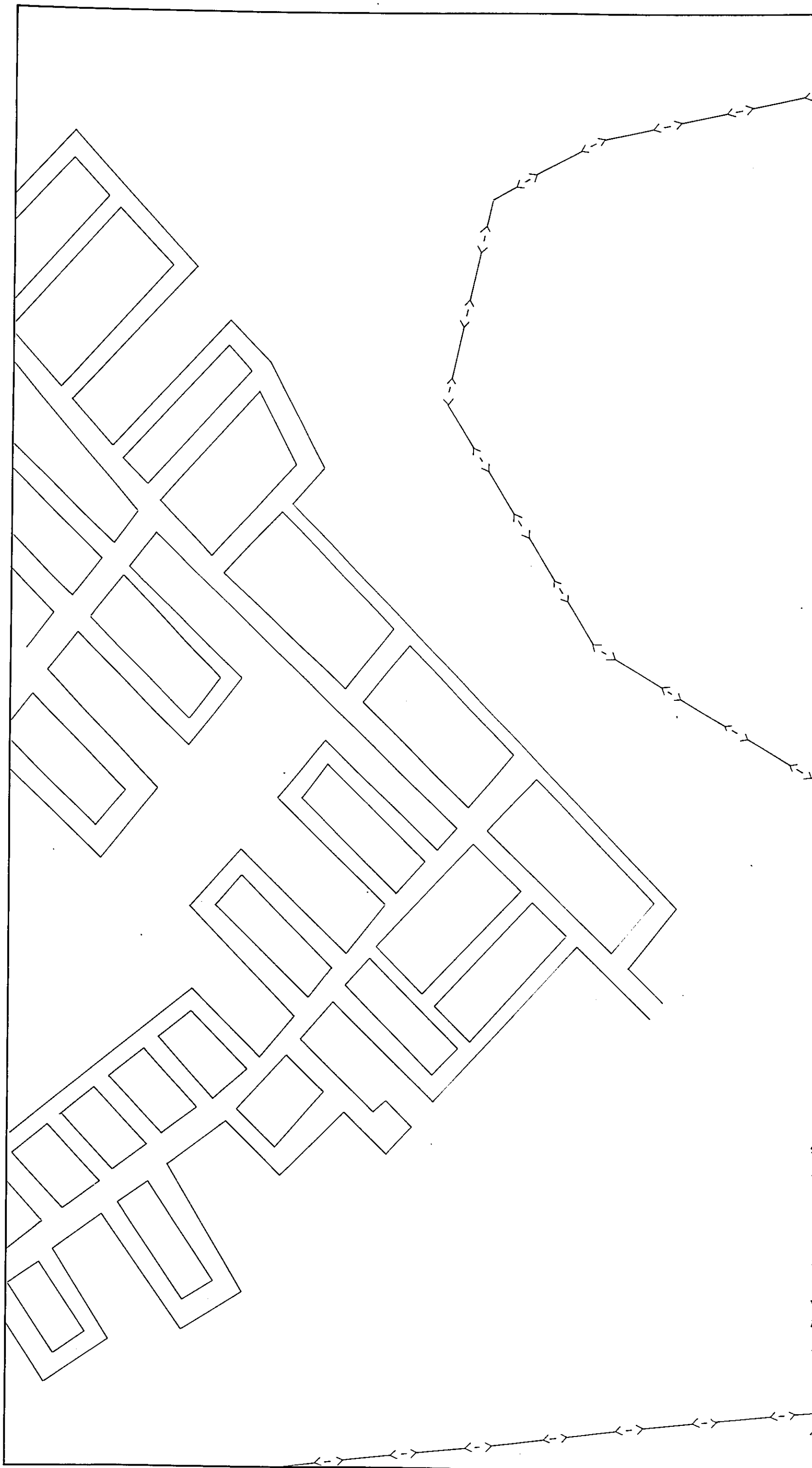

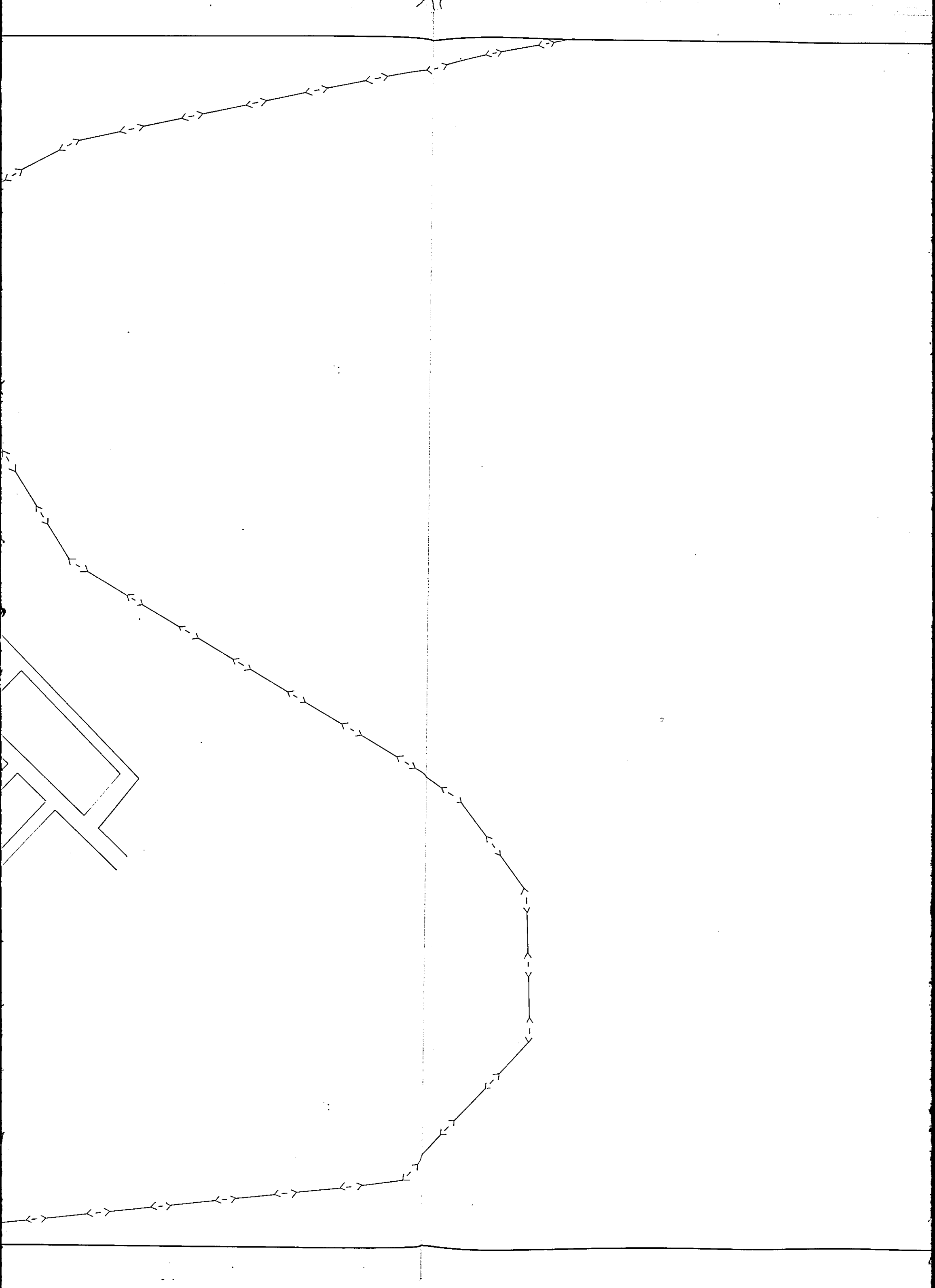

16	22	26
17	(23)	
18		

Exchange	Mayangon
Drawing	Subscriber Aerial Cable Plan
Drawing No	III. 9. 23/27

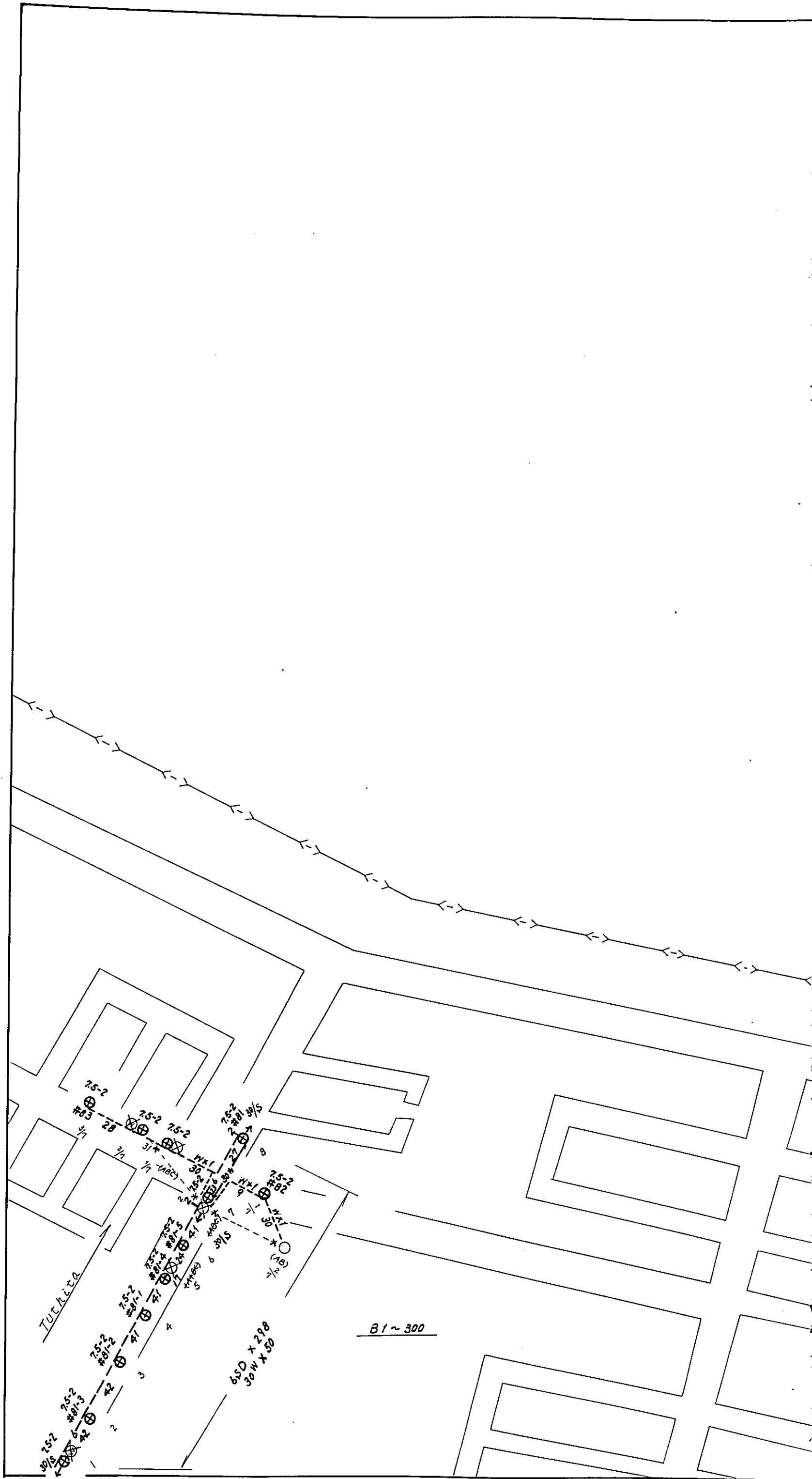

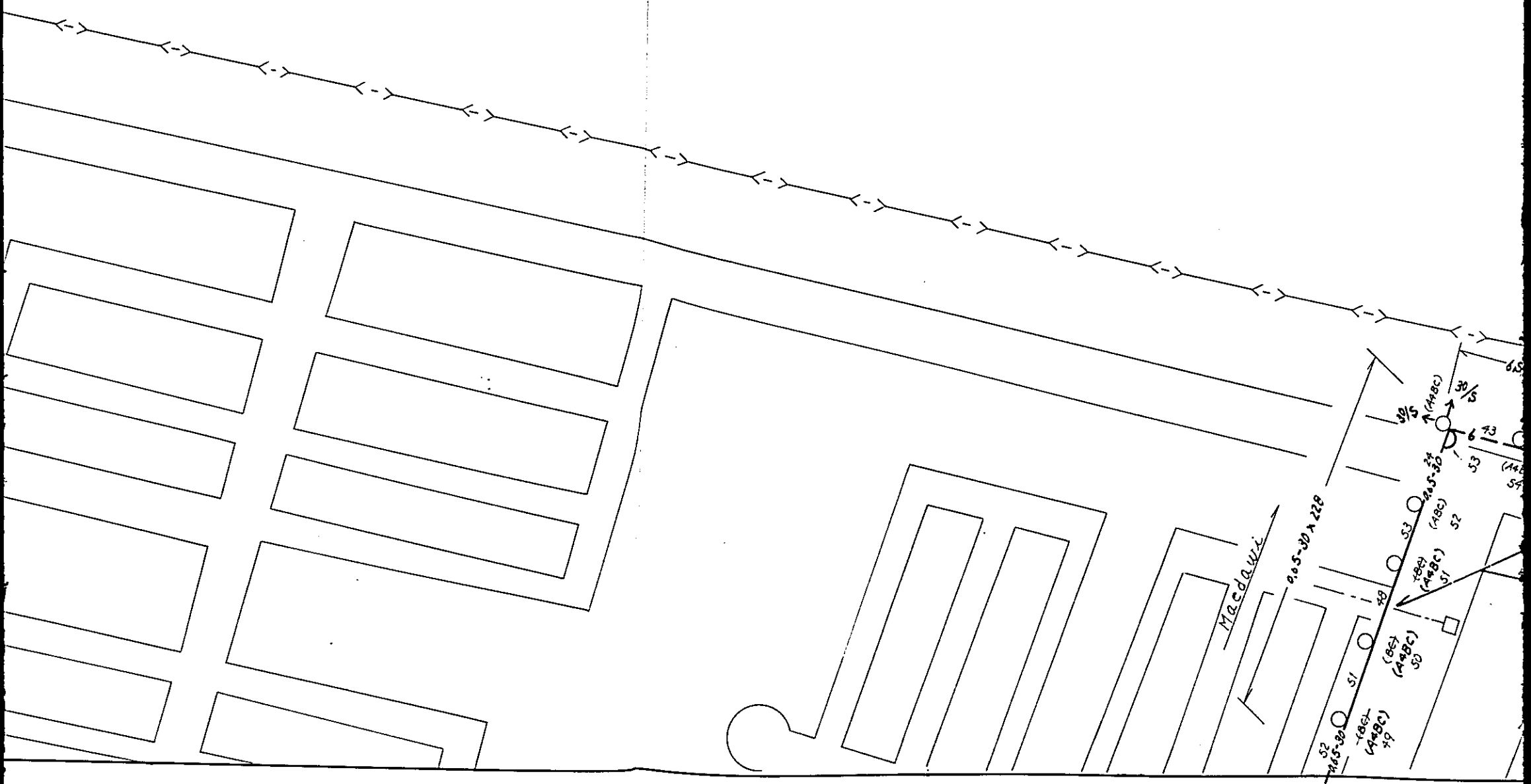

20	24	
21	25	27

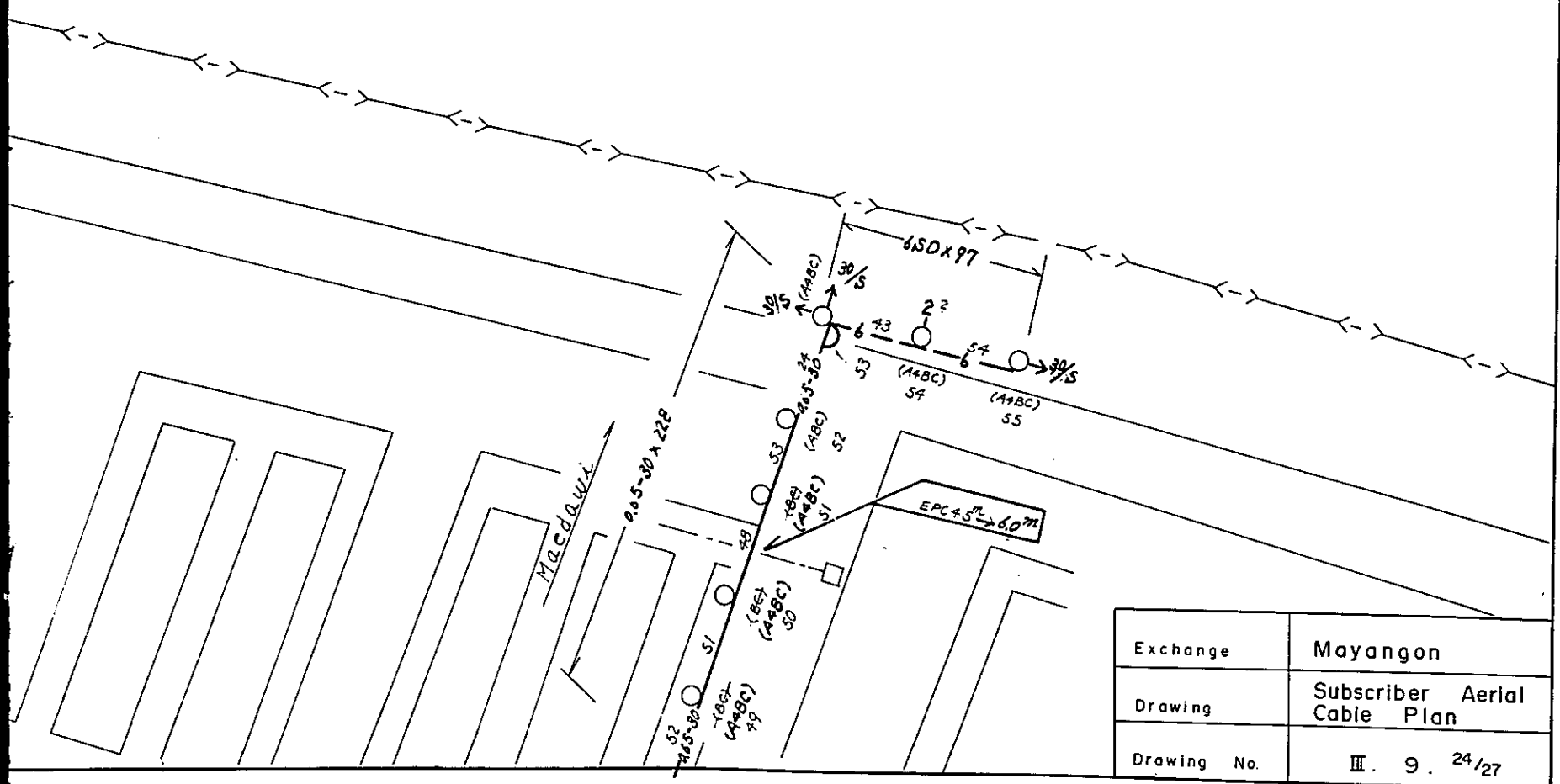

Exchange	Mayangon
Drawing	Subscriber Aerial Cable Plan
Drawing No.	III . 9 . 24/27

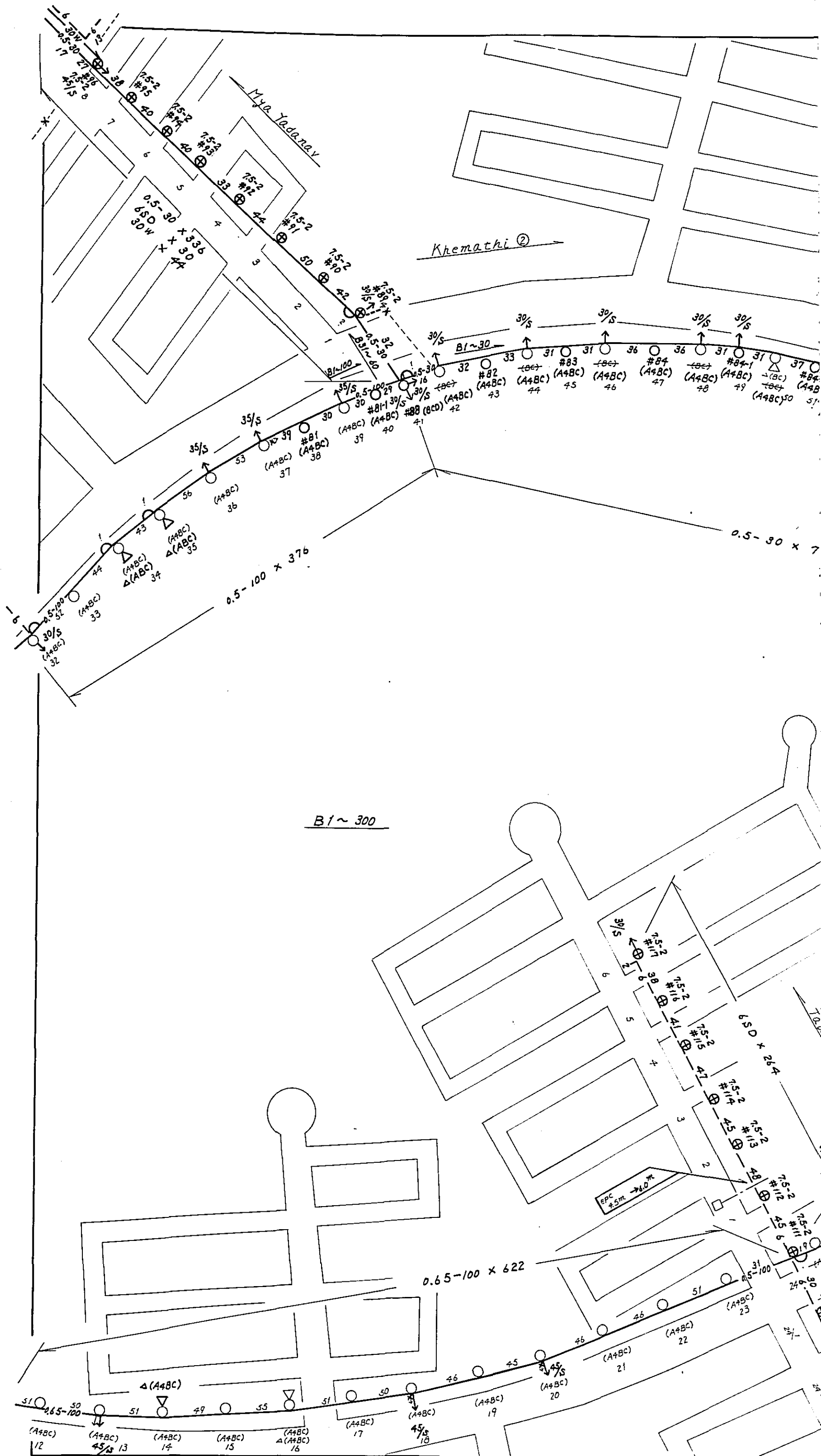

Mya Yadanay

Khemathi 2

B1 ~ 300

EPC 7.5m -> 6.0m

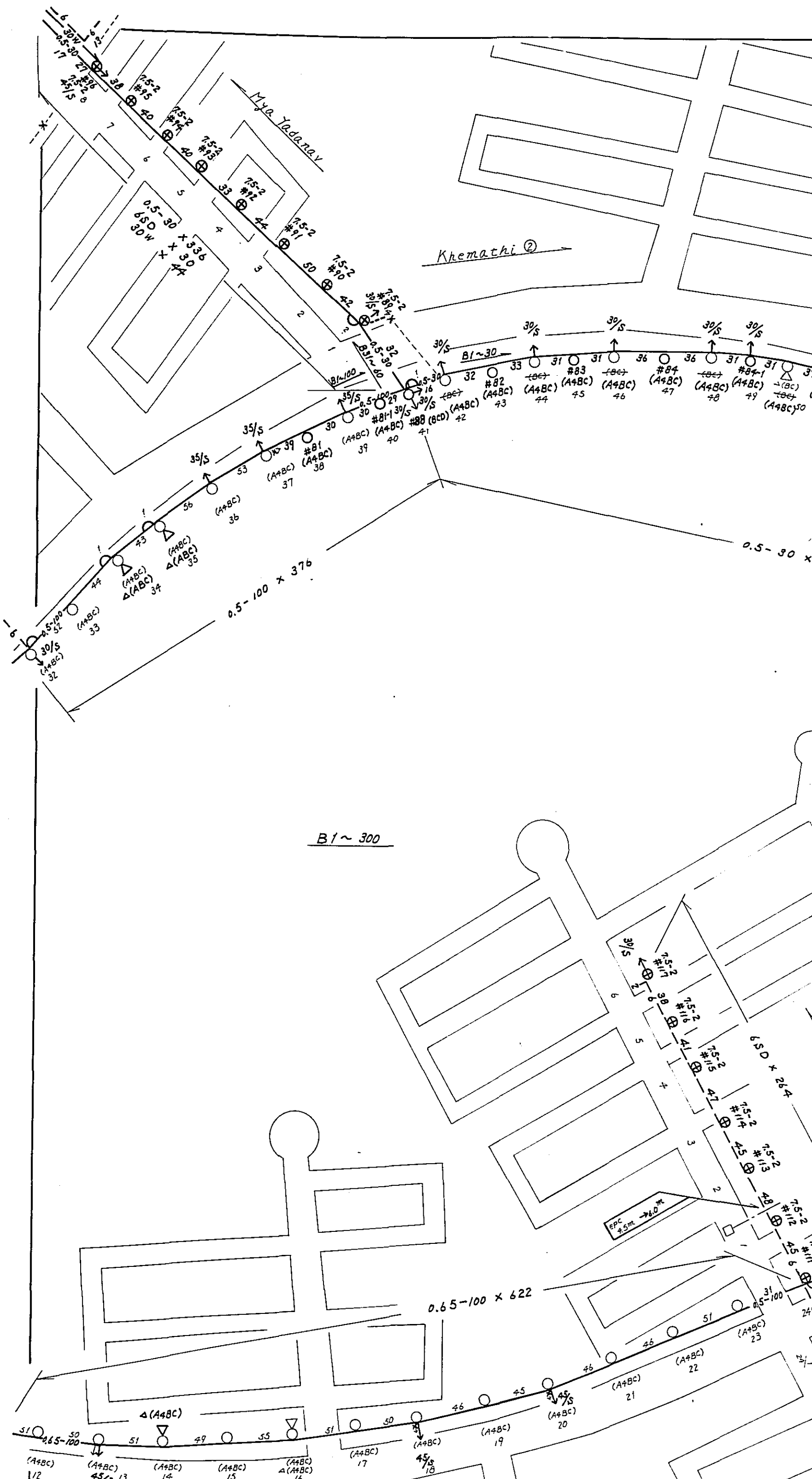

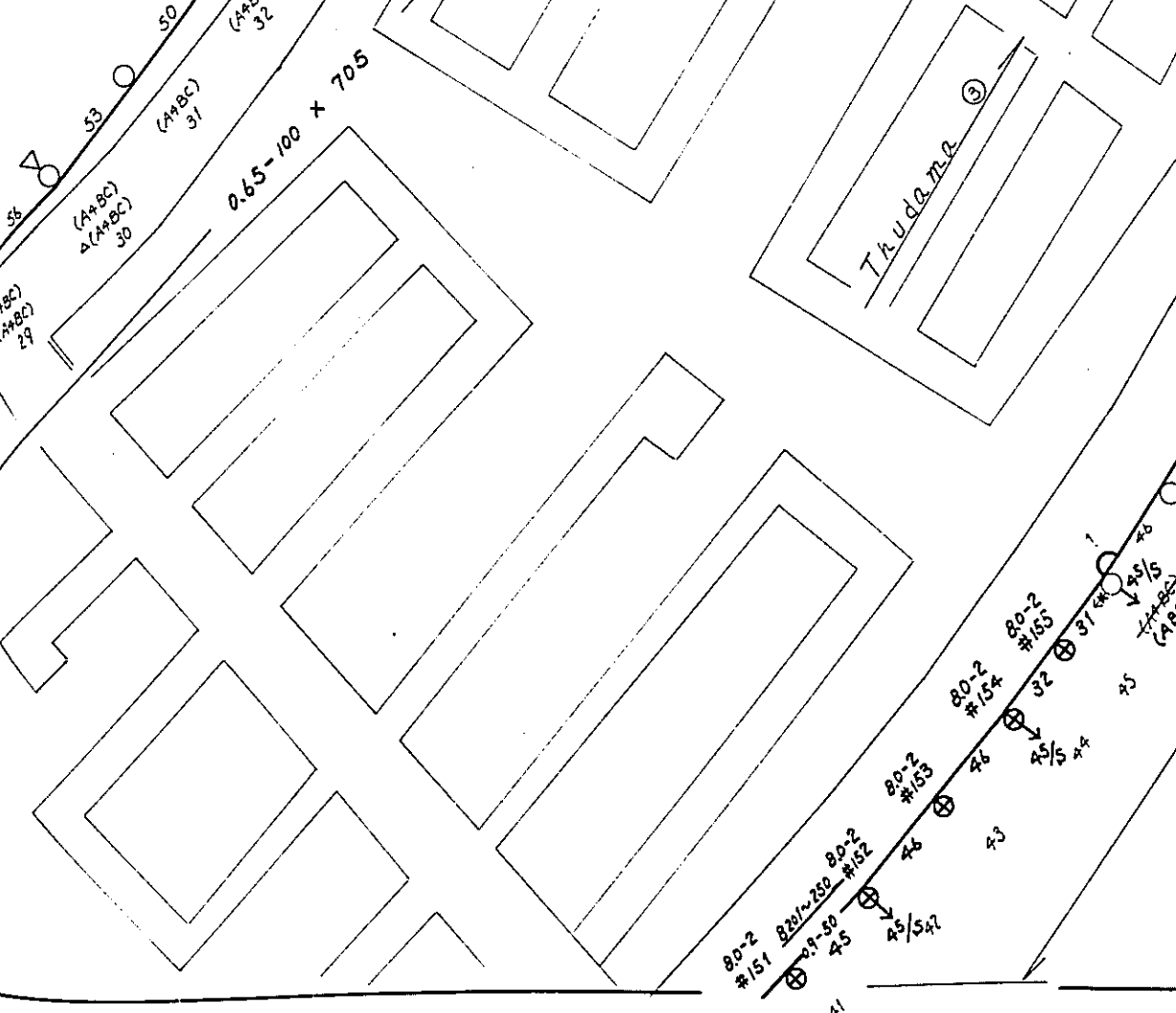
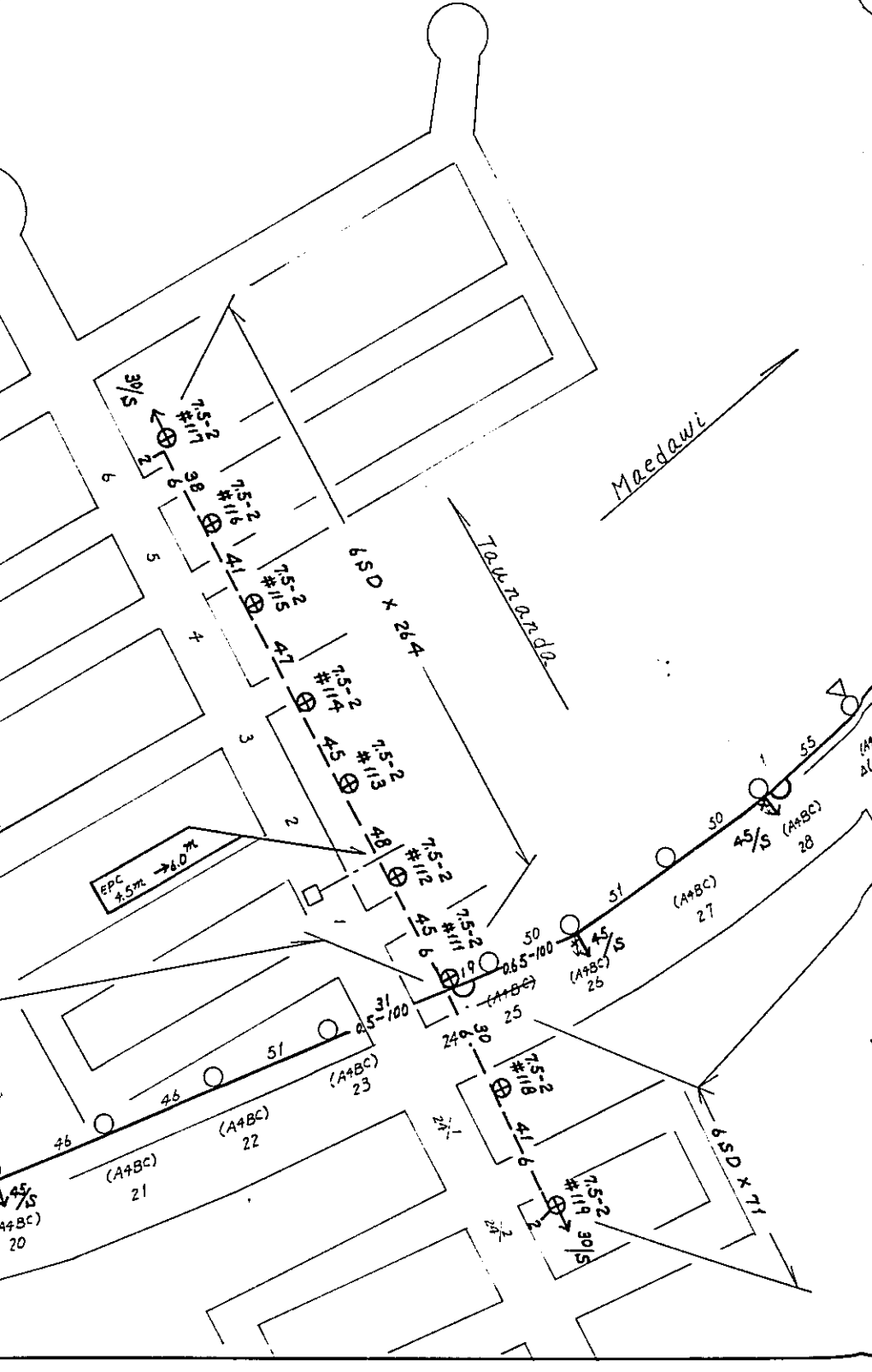
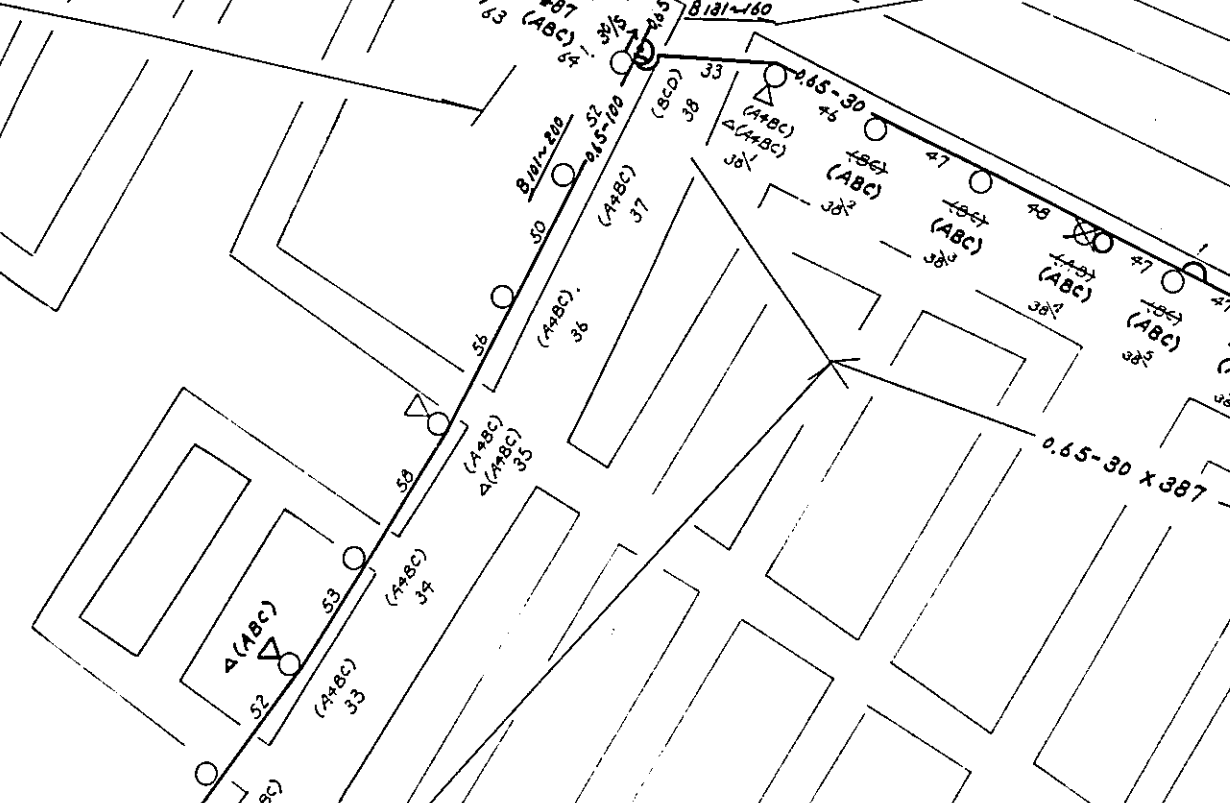
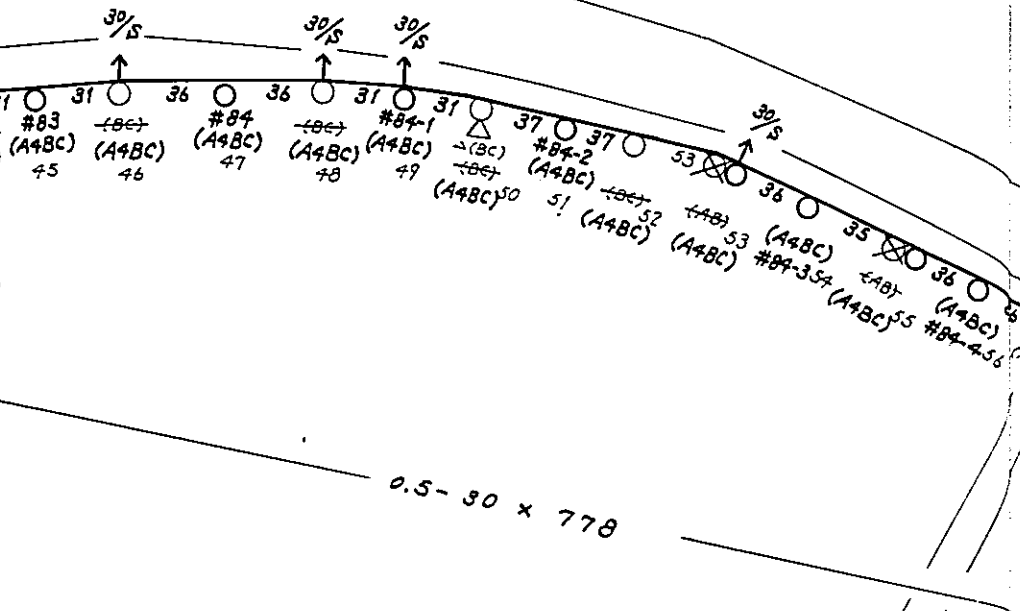
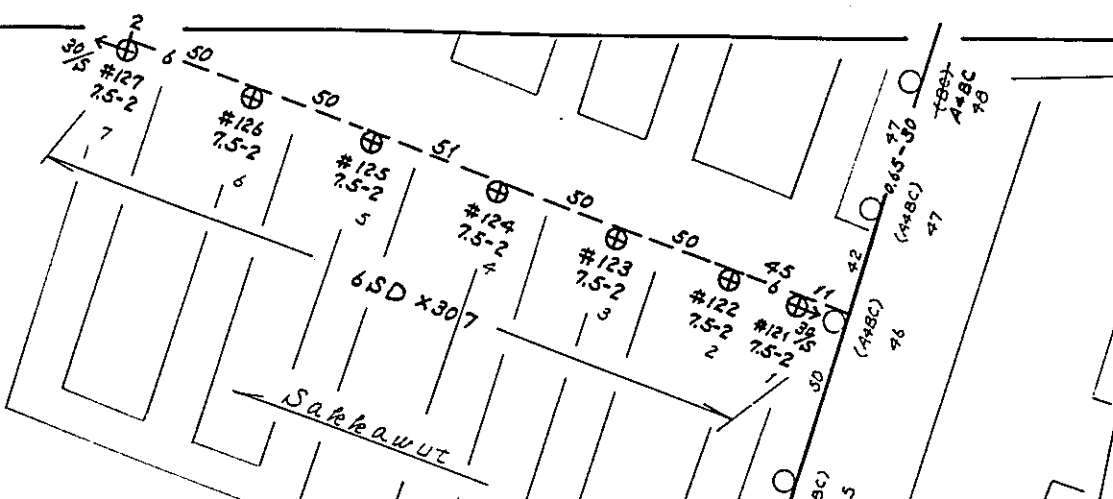
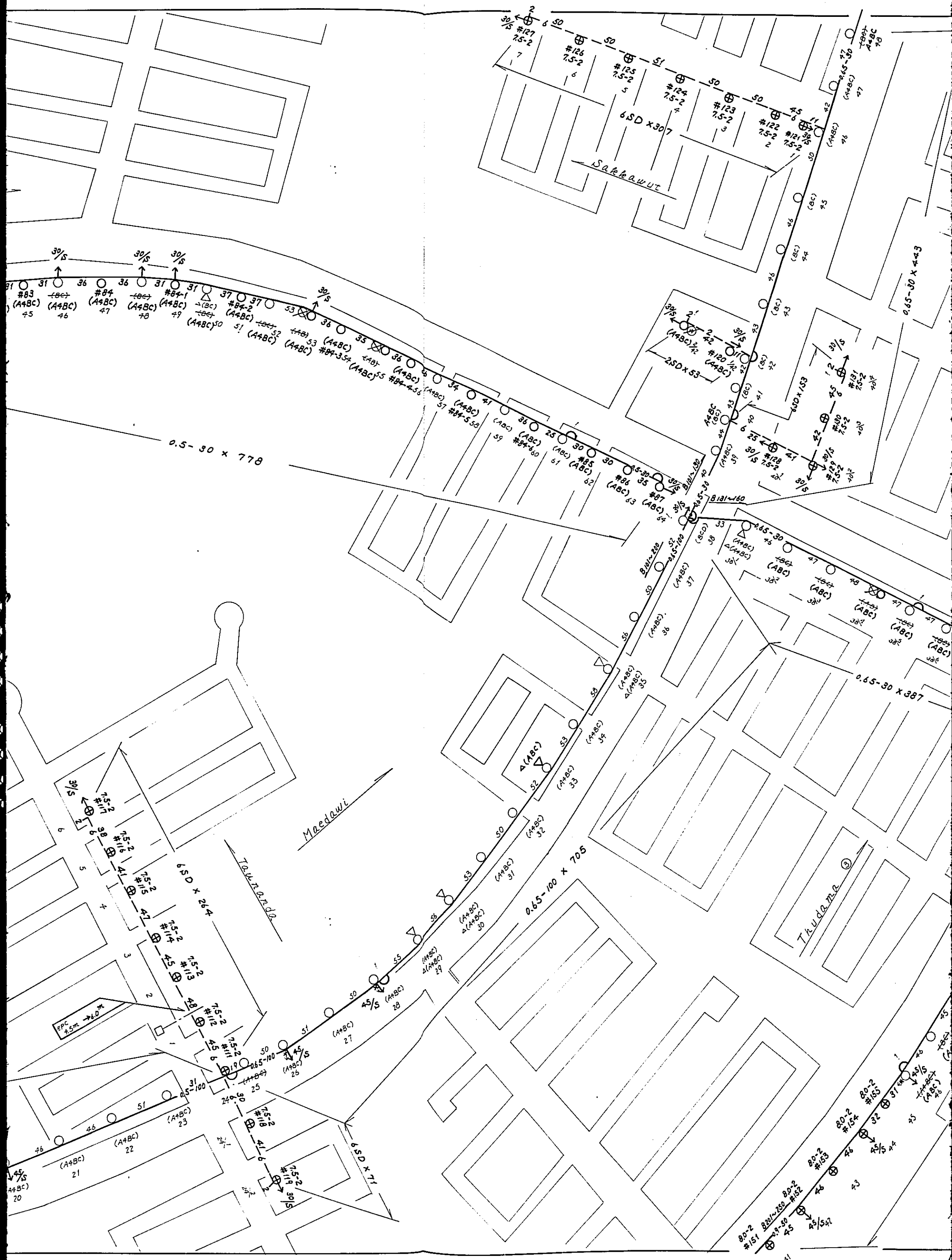

20	24	
21	(25)	27
22	26	

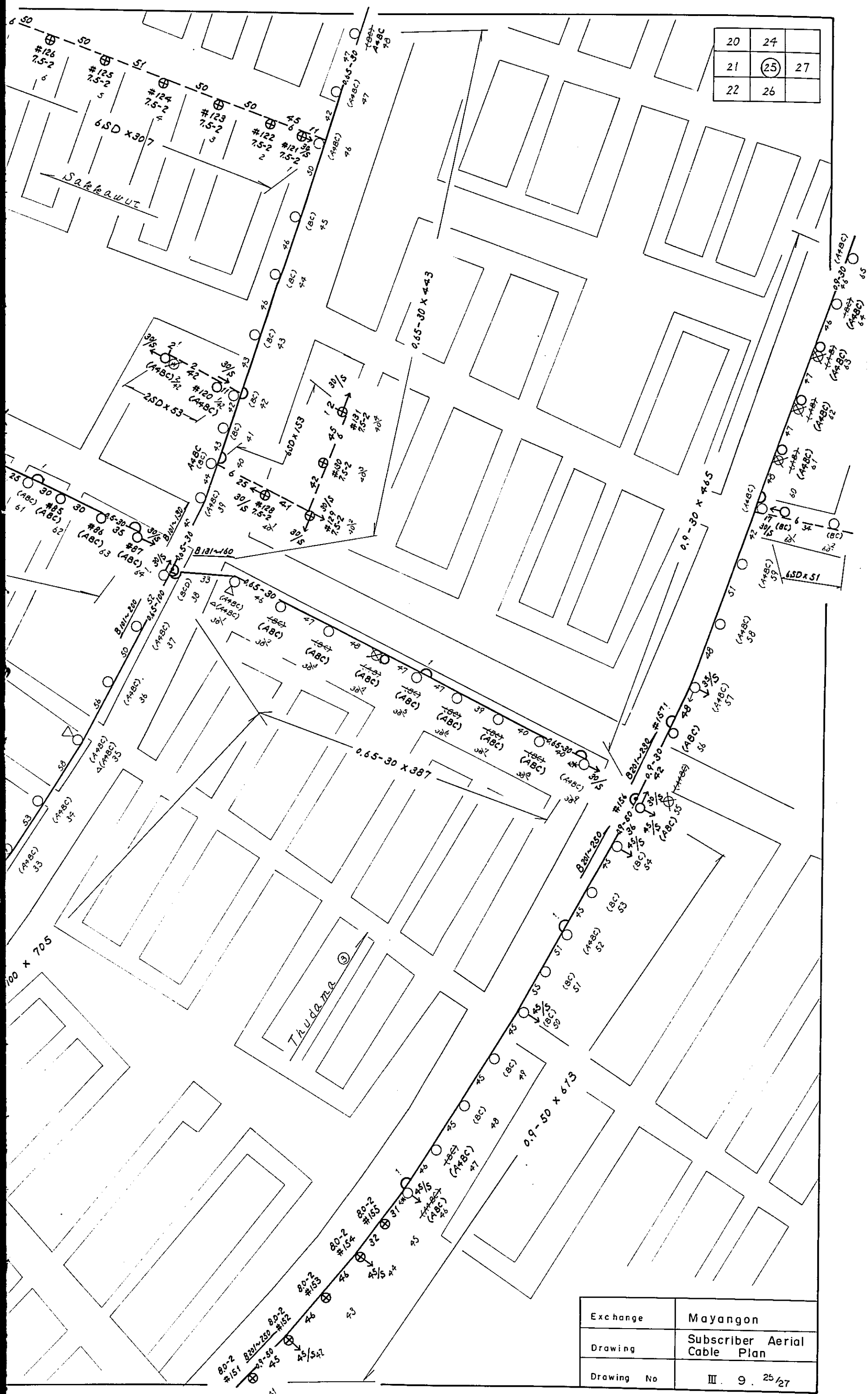

Exchange	Mayangon
Drawing	Subscriber Aerial Cable Plan
Drawing No	III. 9. 25/27

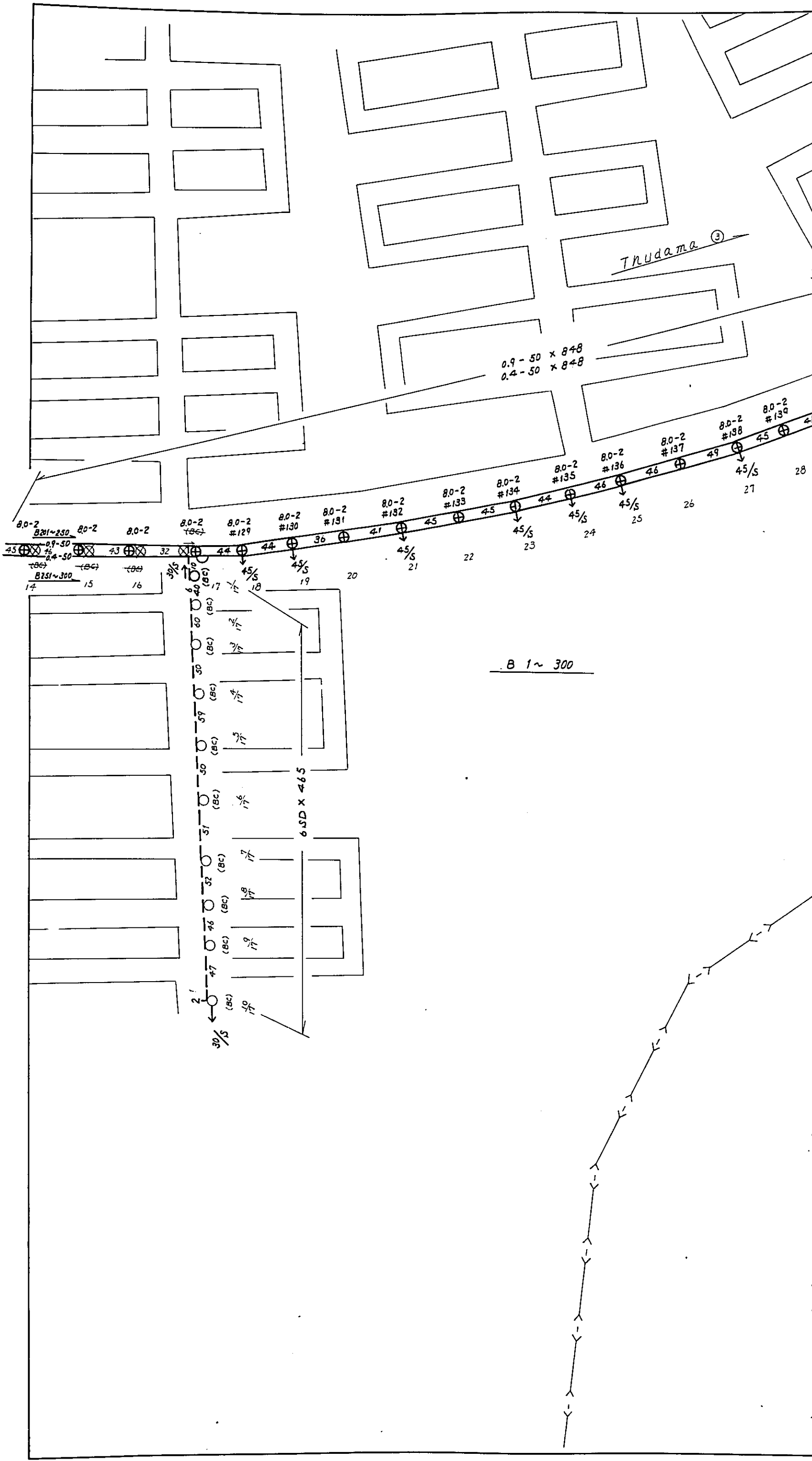

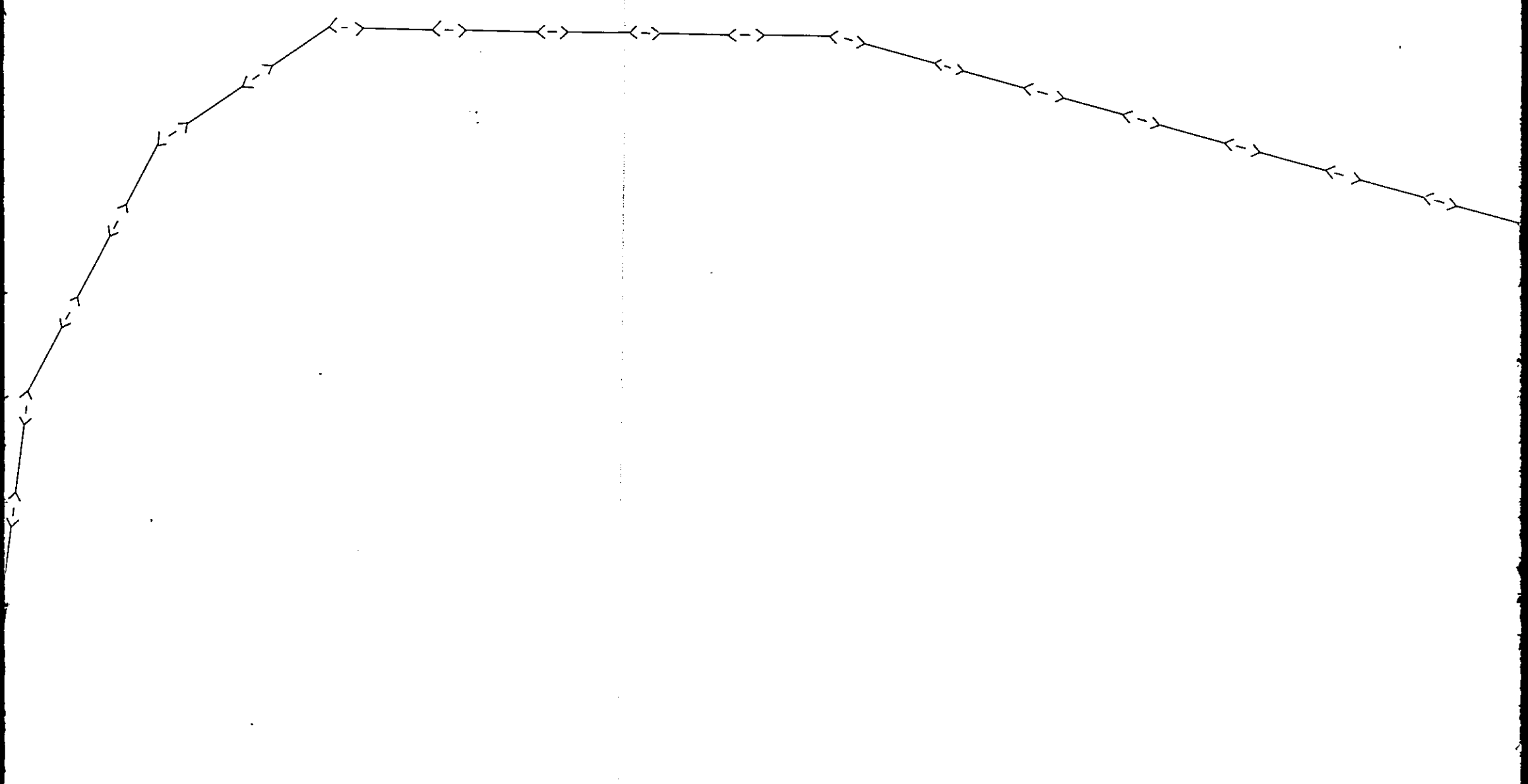
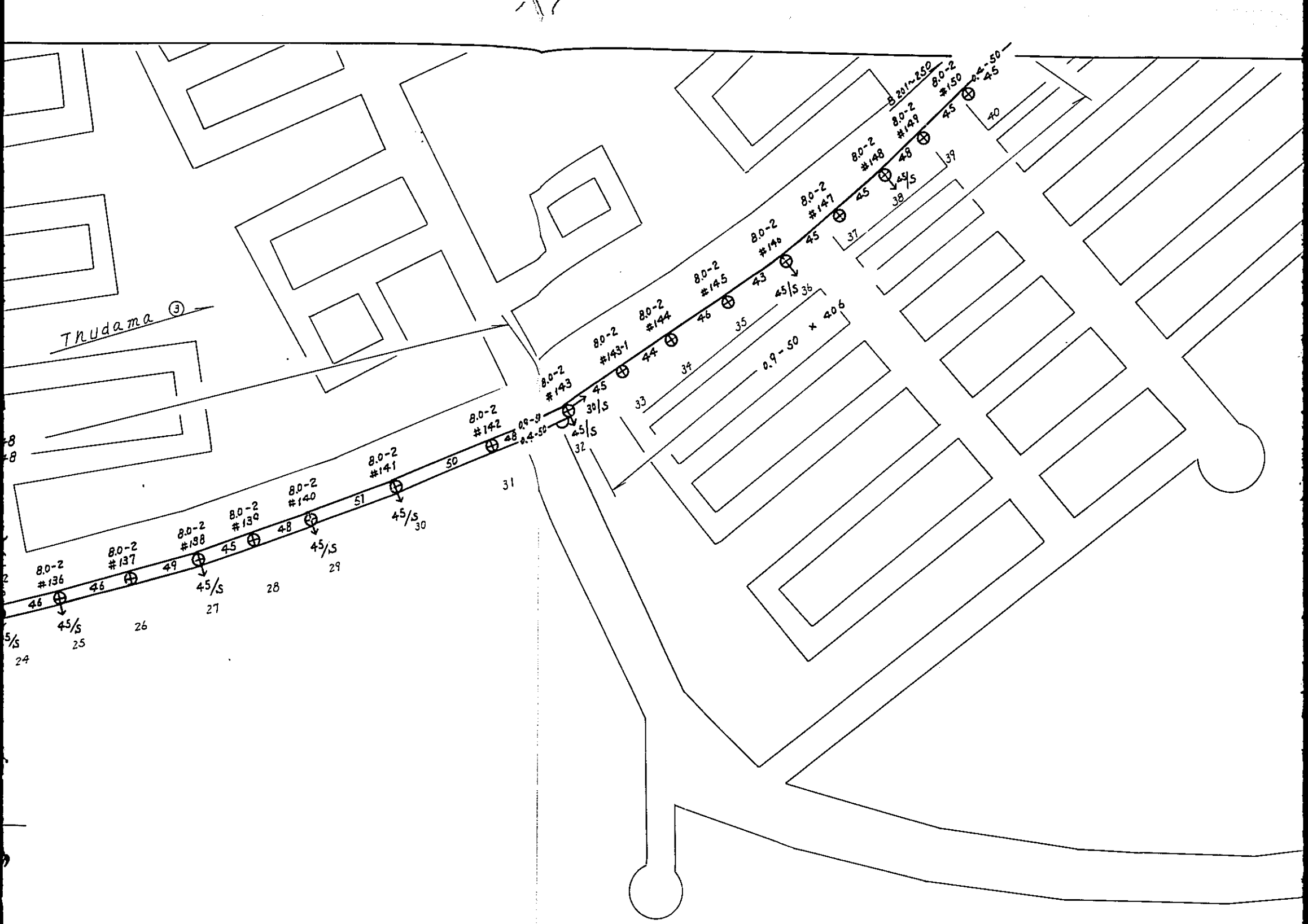

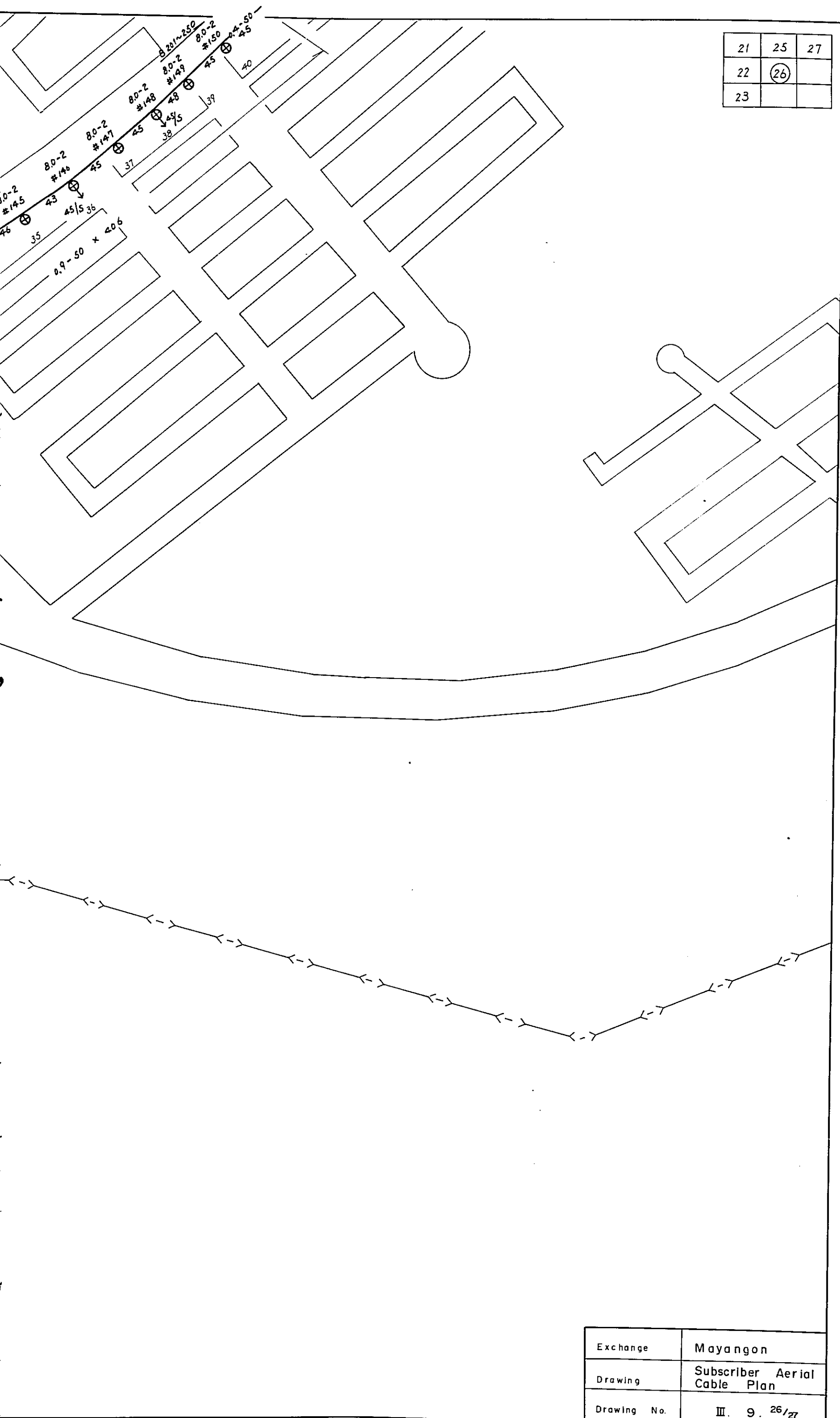

21	25	27
22	(26)	
23		

Exchange	Mayangon
Drawing	Subscriber Aerial Cable Plan
Drawing No.	III. 9. 26/27

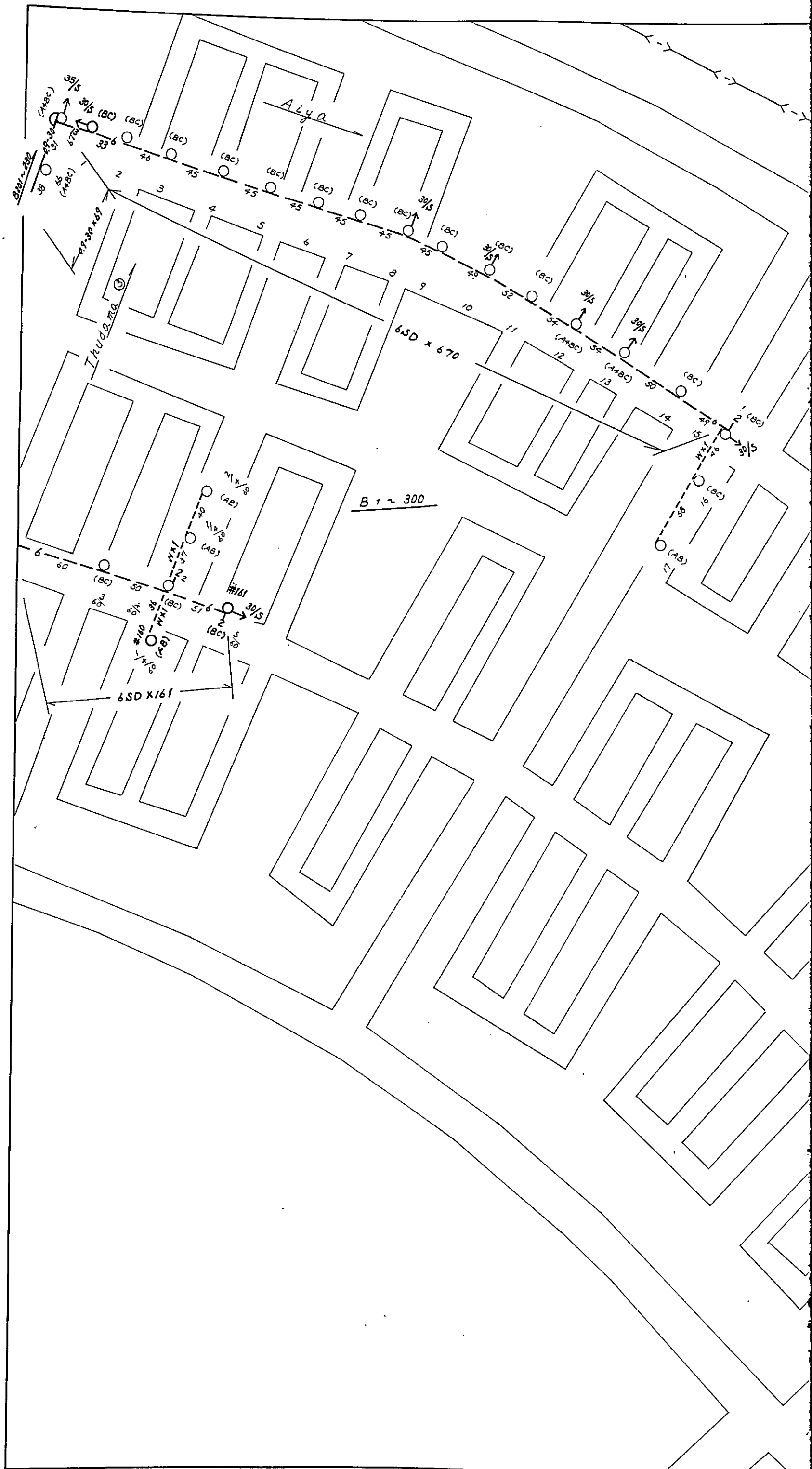

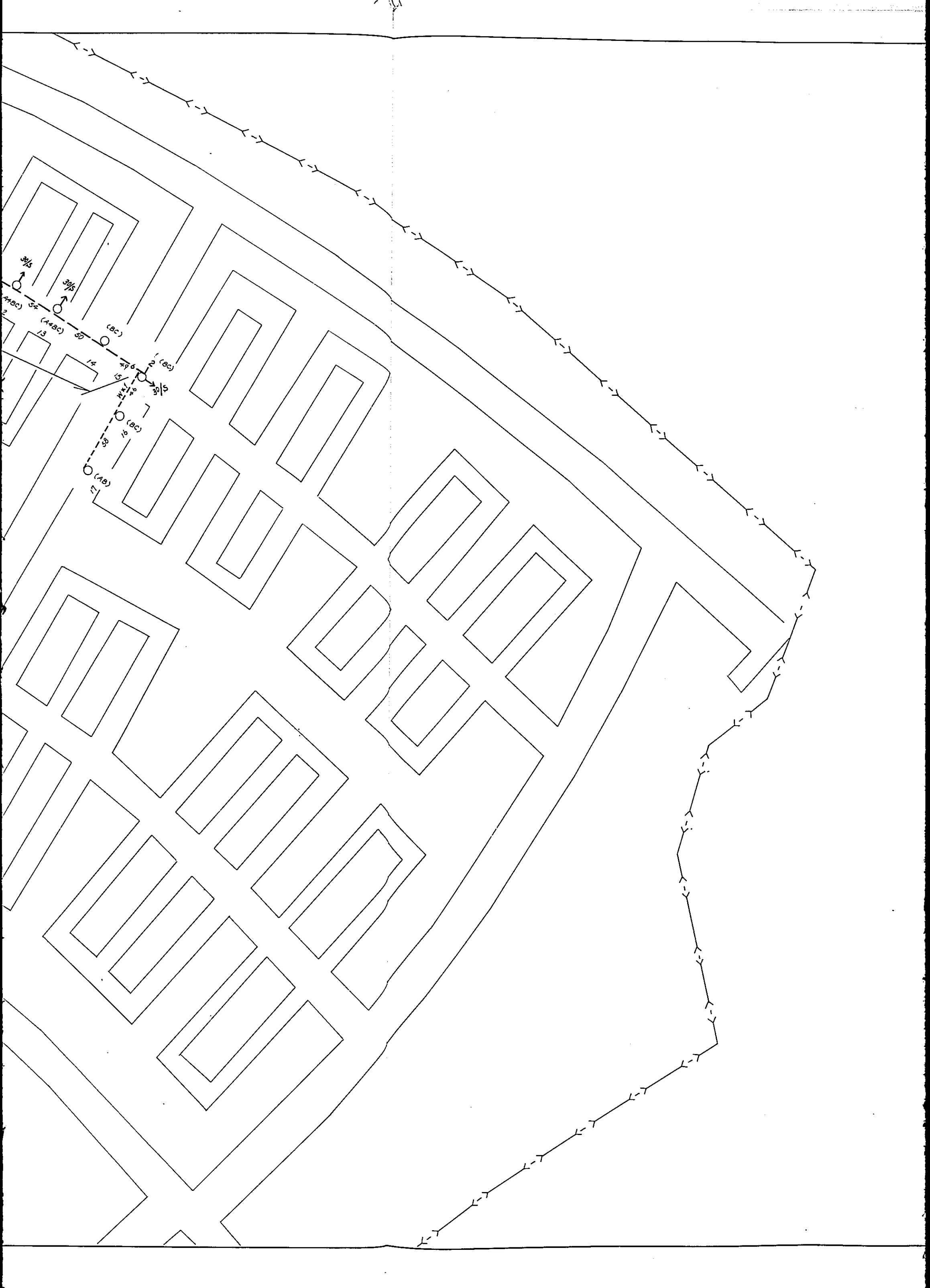

24		
25	(27)	
26		

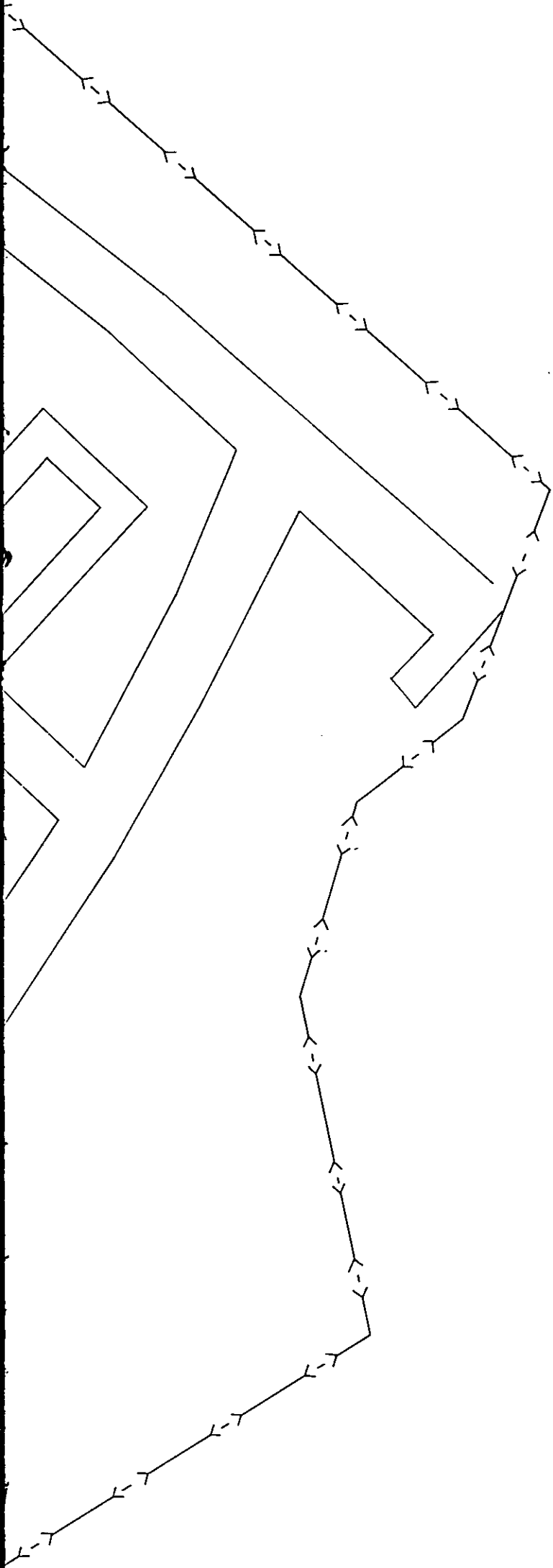

Exchange	Mayangon
Drawing	Subscriber Aerial Cable Plan
Drawing No	III. 9. 27/27

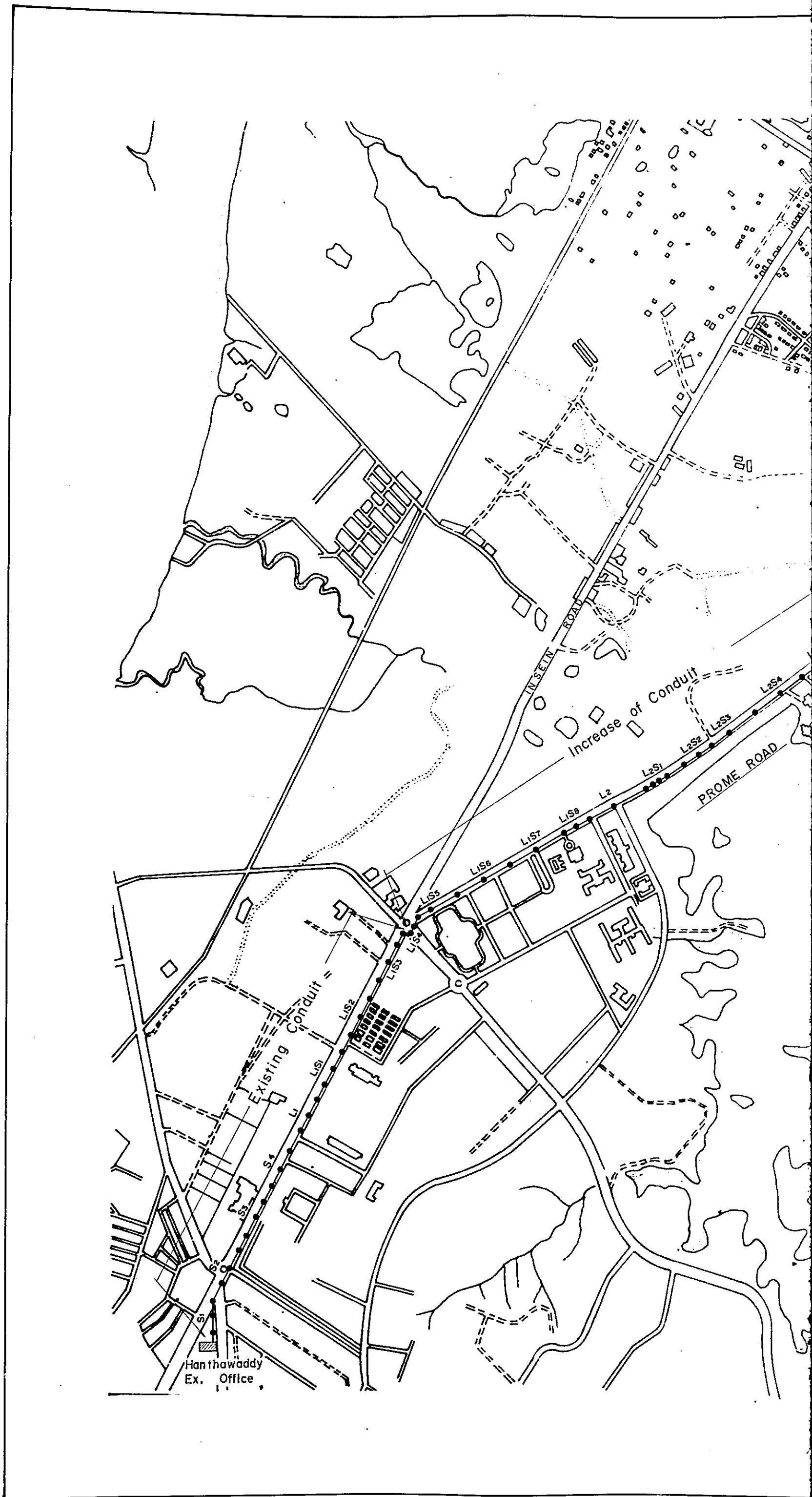

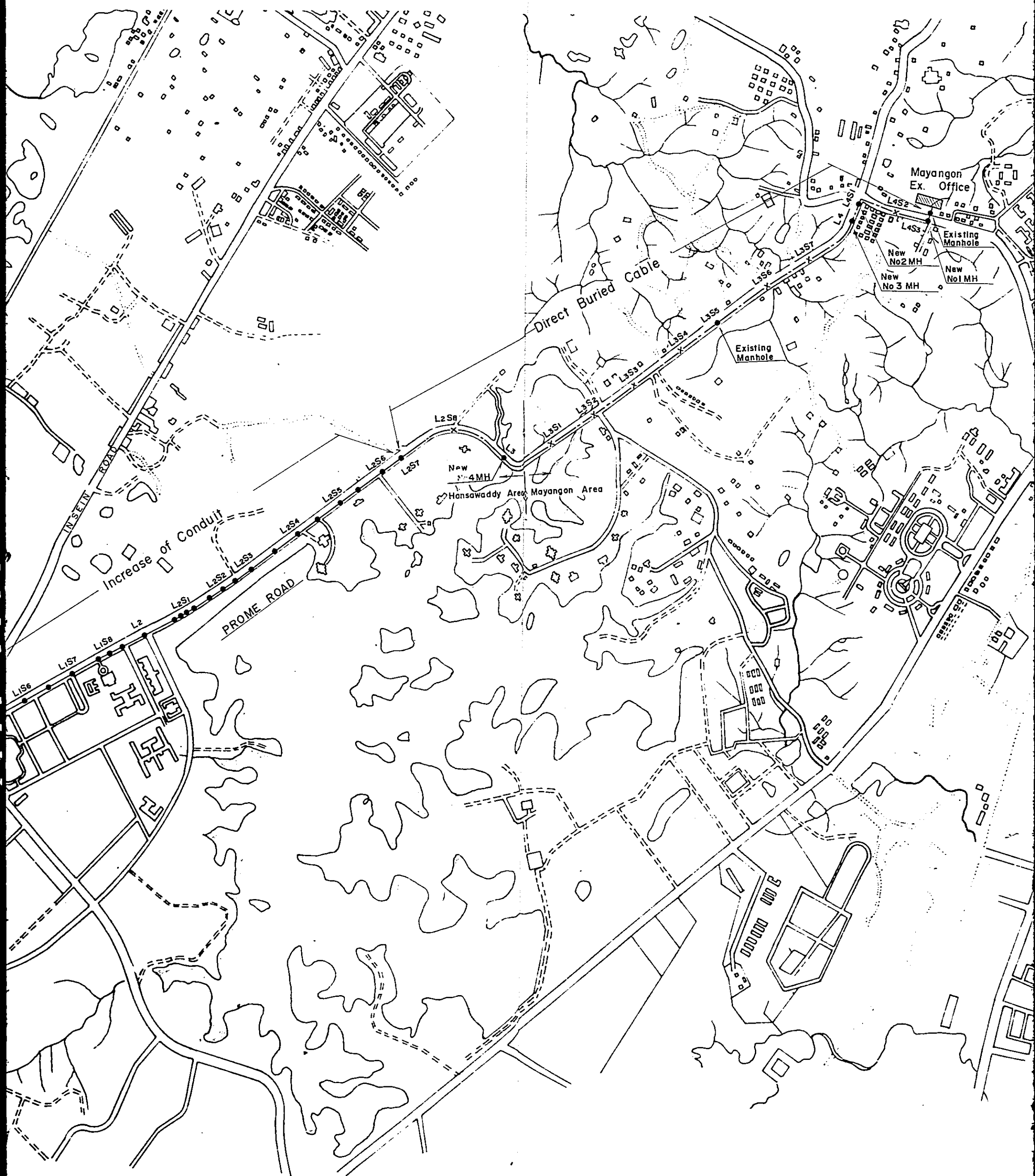

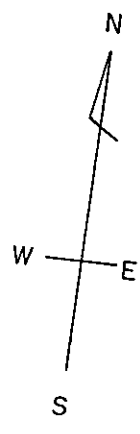

Exchange	Mayangon
Drawing	Guide Map of Junction Cable Route
Drawing No.	III. 10. 1

Hanthawaddy
Exchange Office

(80) 824.9

Loading-coil Manhole Name	
Loading Coil	
Remarks	

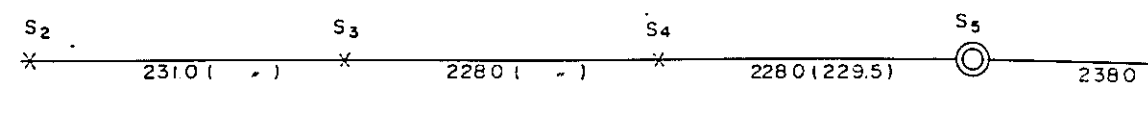
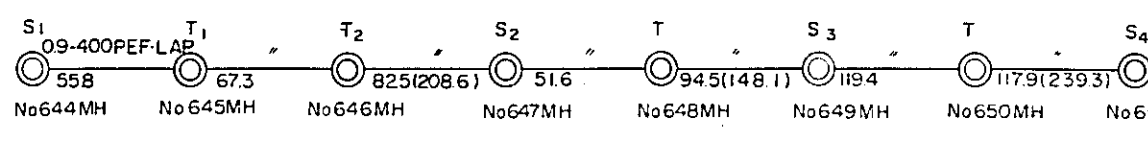
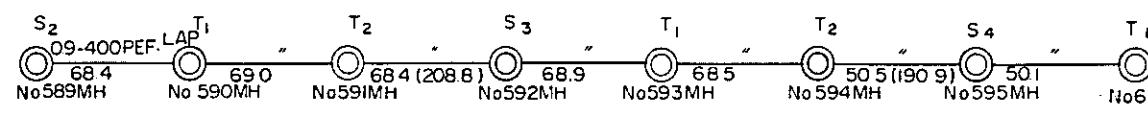
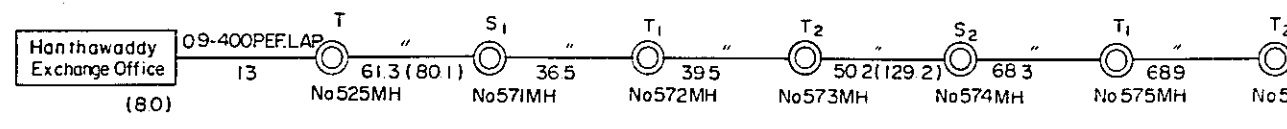

Hanthawaddy
Exchange Office
(8.0)

Mayangon
Exchange Office
(32.5)

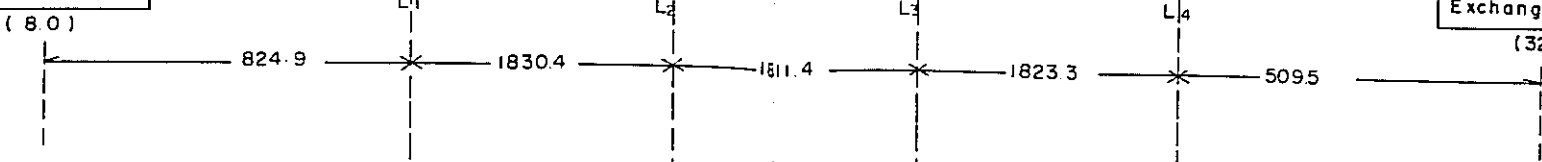

Loading-coil Manhole Name	No 583 MH	No 641 MH	New No 4 MH	New No 3 MH
Loading Coil	Coil Spacing 1830m 88 mH			
Remarks				

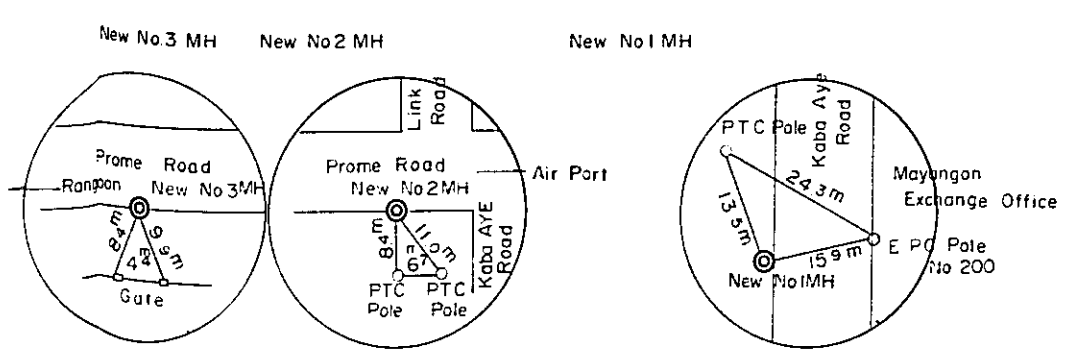
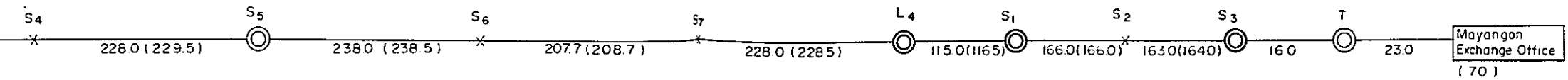
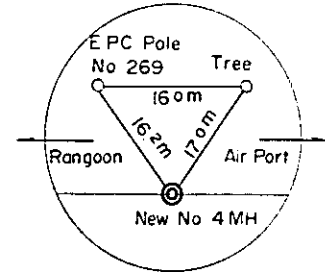
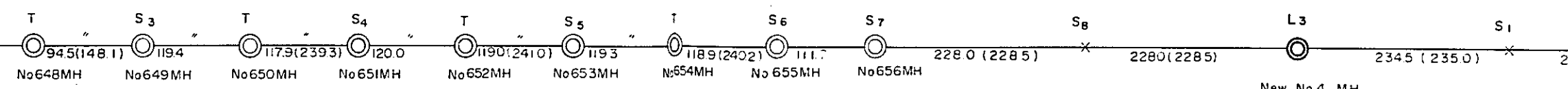
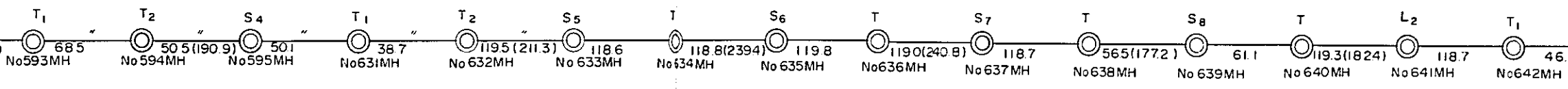
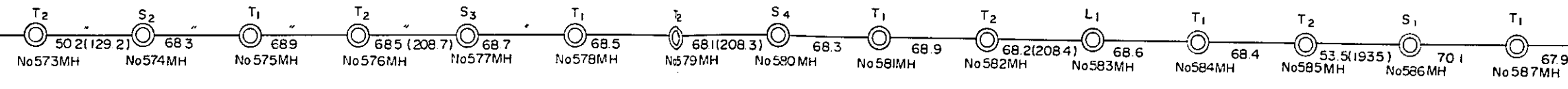

Mayangon
Exchange Office
(32.5)

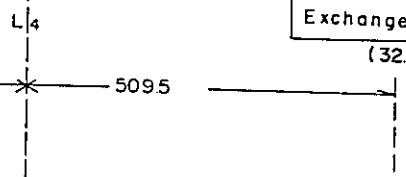

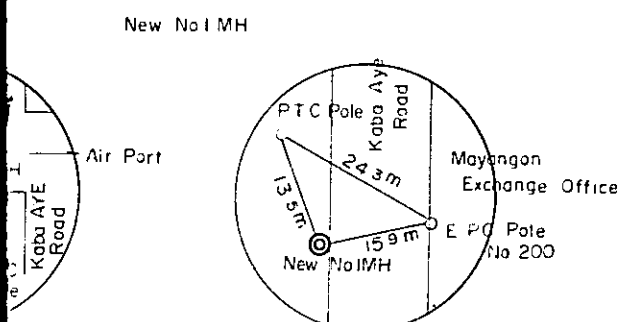
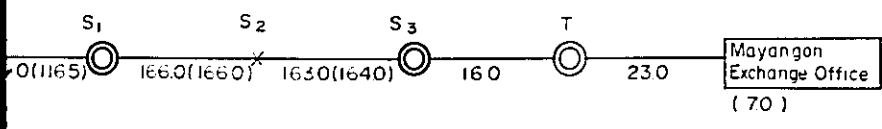
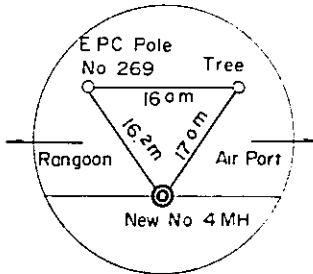
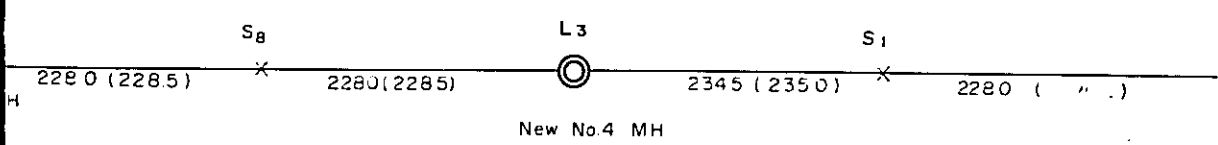
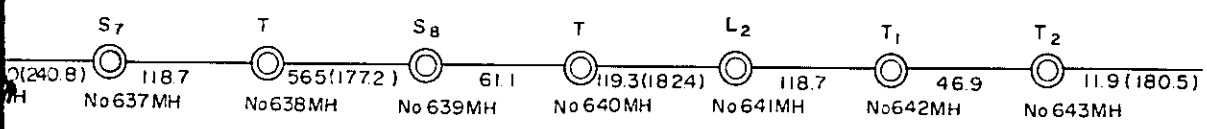
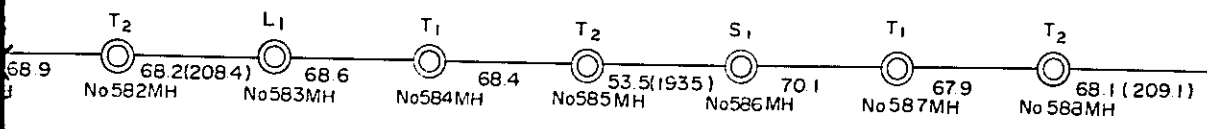

New No 3 MH	

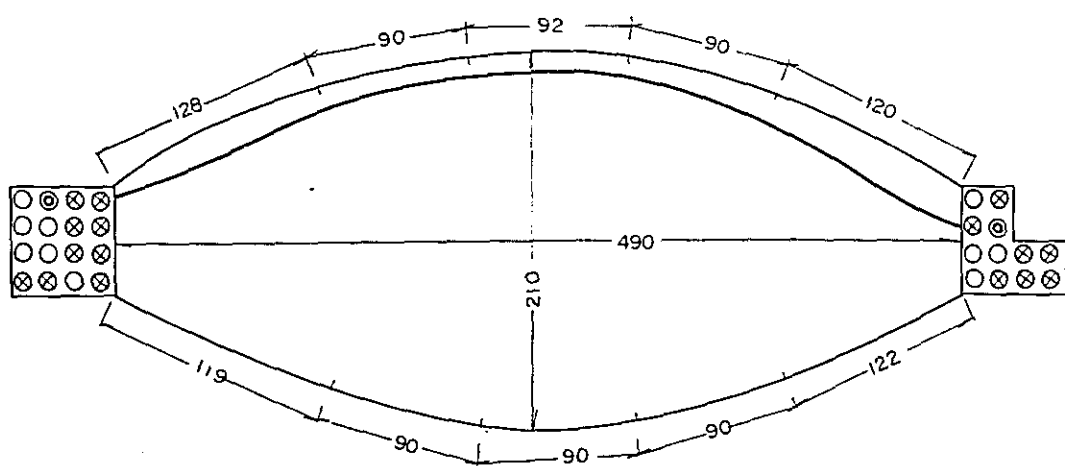

Exchange	Mayangon
Drawing	Diagram of Junction Cable Route
Drawing No.	III . 11. 1

NO. 525 M.H.



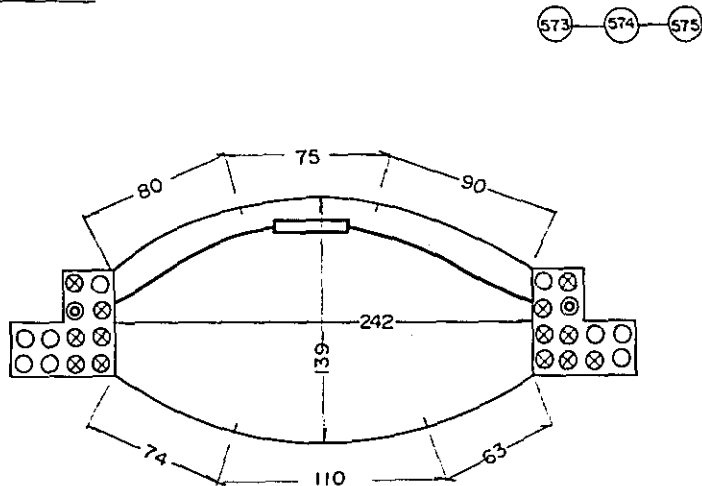

 525 57
 Hanthawaddy
 Ex office

NO. 574 M.H.

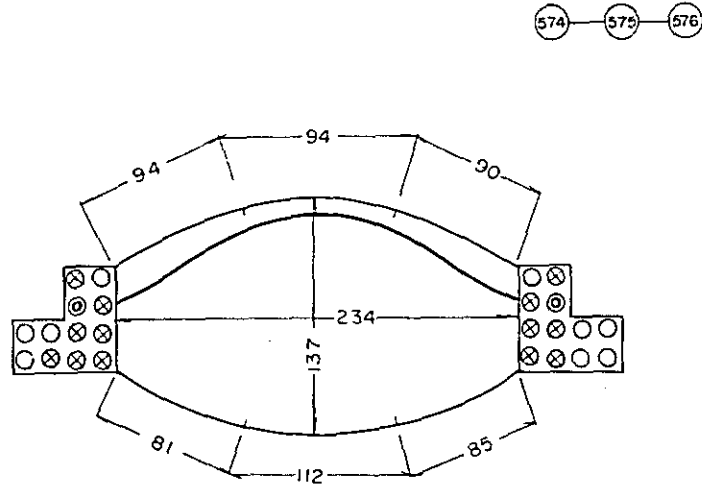

573 574 575

NO. 575 M.H.



574 575 576

NO. 579 M.H.

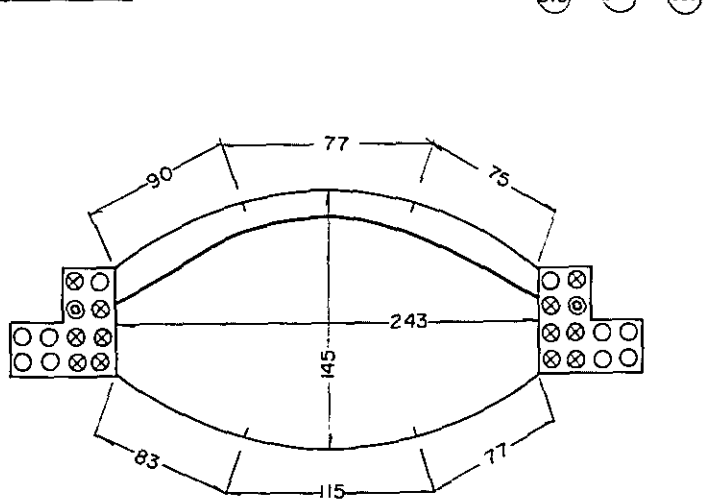

578 579 580

NO. 580 M.H.

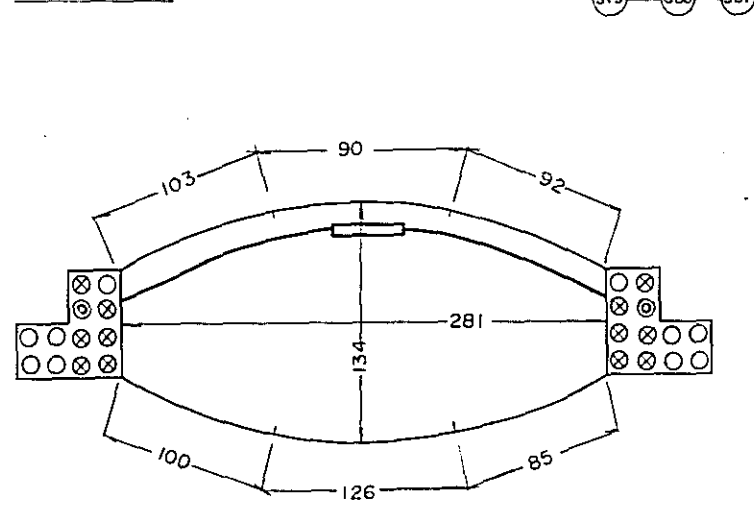

579 580 581

NO. 584 M.H.

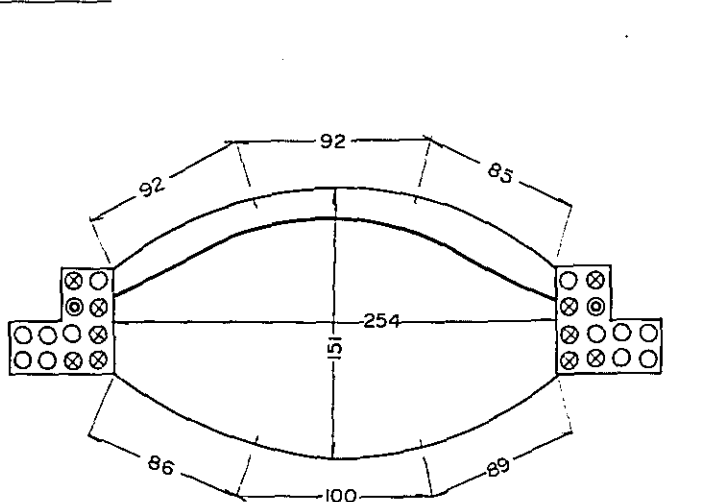

583 584 585

NO. 585 M.H.

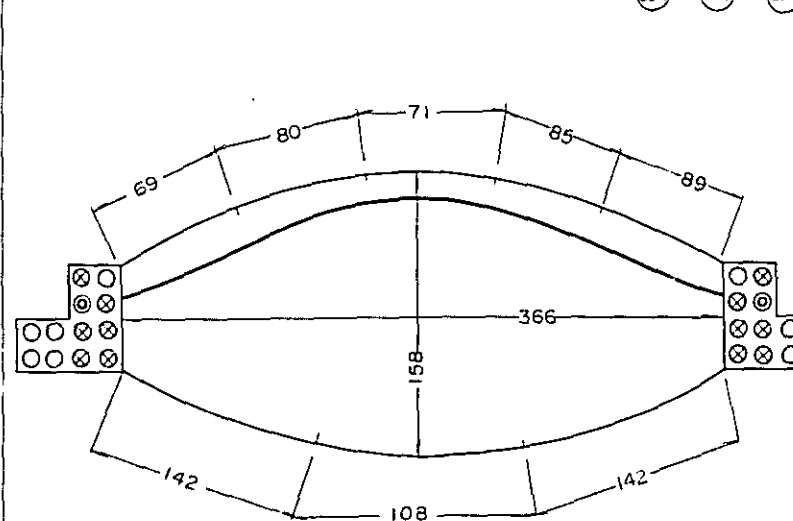

584 585 586

 525—571
 Hanthawaddy
 Ex office

NO. 571 M.H.

525—571—572

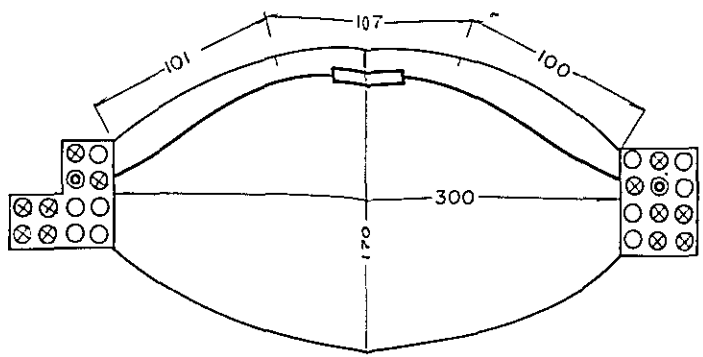

NO. 572 M.H.

571—572—573

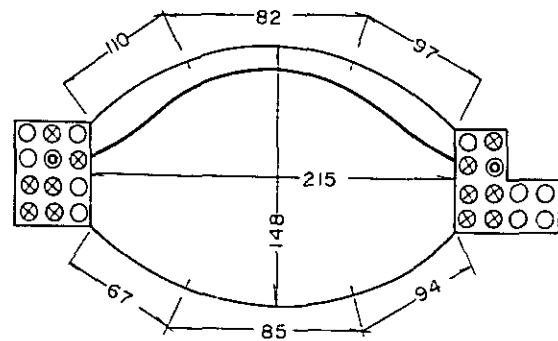

NO. 57

NO. 576 M.H.

575—576—577

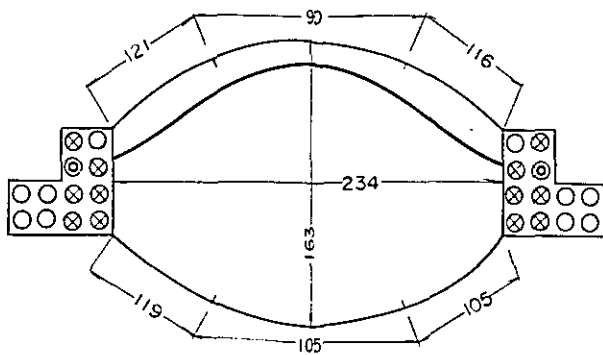

NO. 577 M.H.

576—577—578

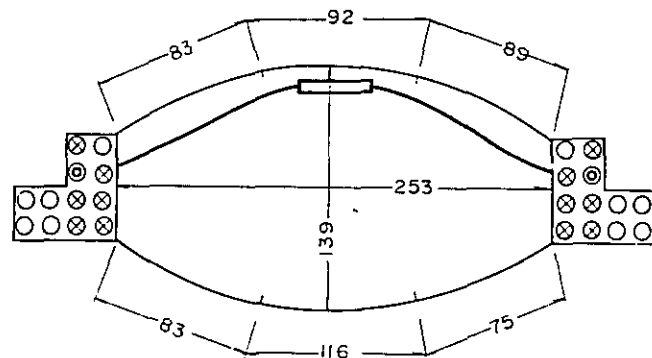

NO. 578

NO. 581 M.H.

580—581—582

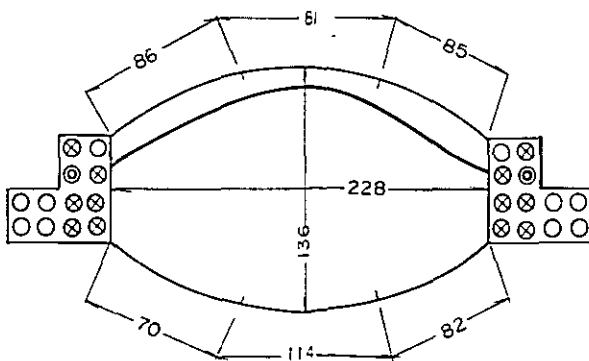

NO. 582 M.H.

581—582—583

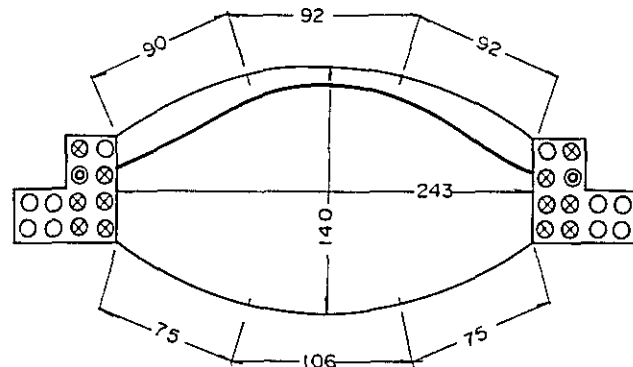

NO. 583

NO. 586 M.H.

585—586—587

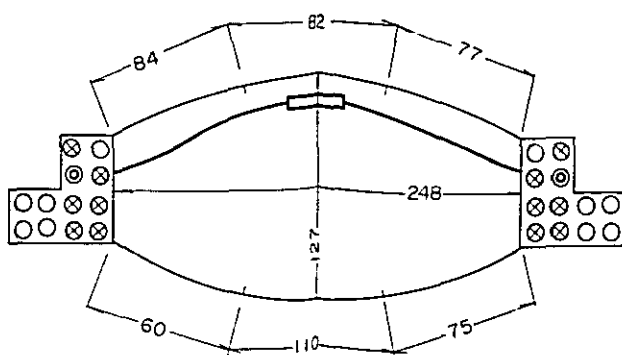

NO. 587 M.H.

586—587—588

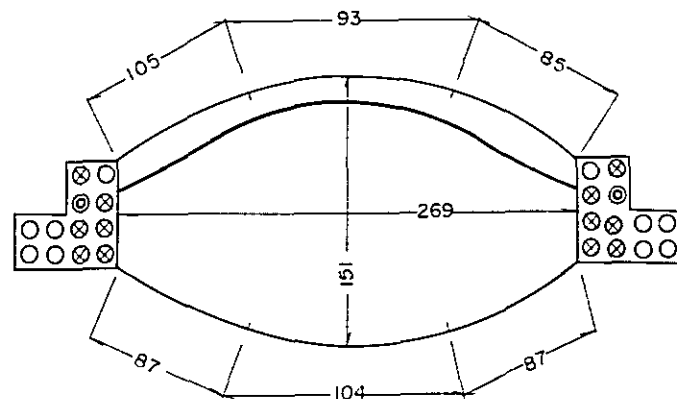

574—575—576

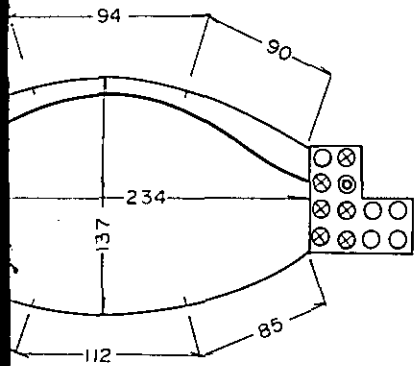

579—580—581

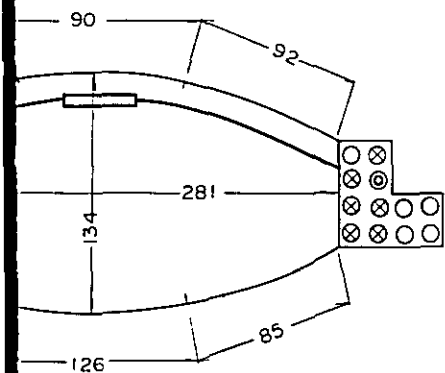

584—585—586

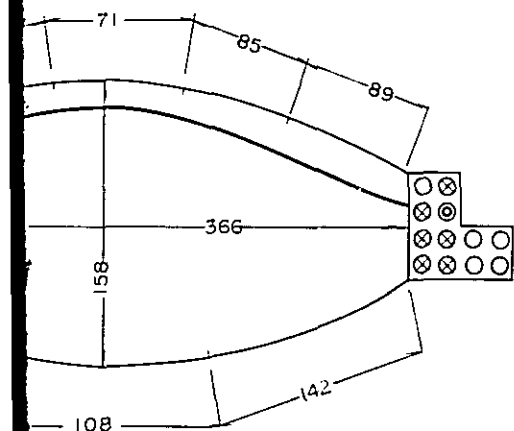

NO 572 M.H.

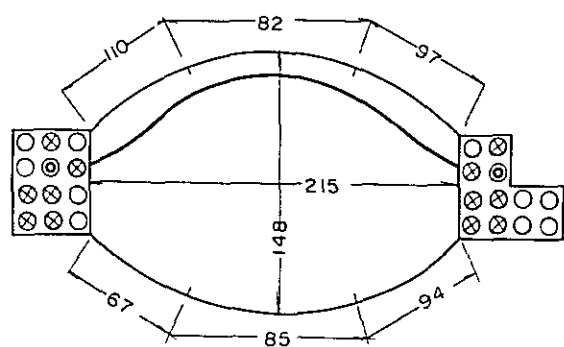

NO. 573 M.H.

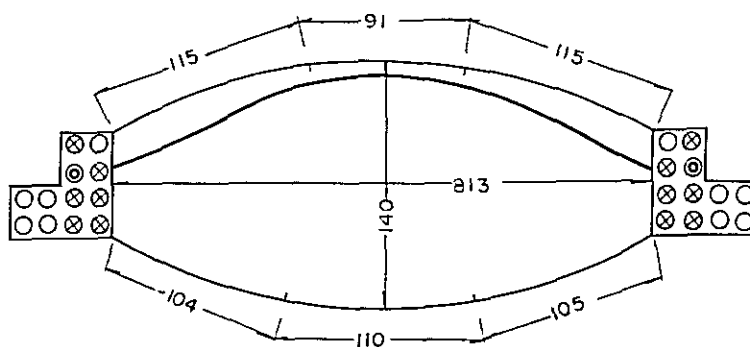

NO 577M.H.

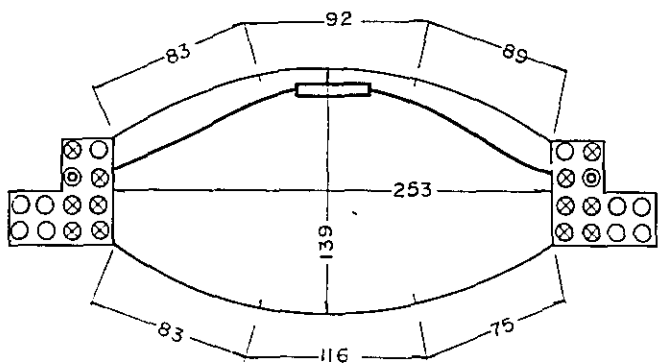

NO. 578 M.H.

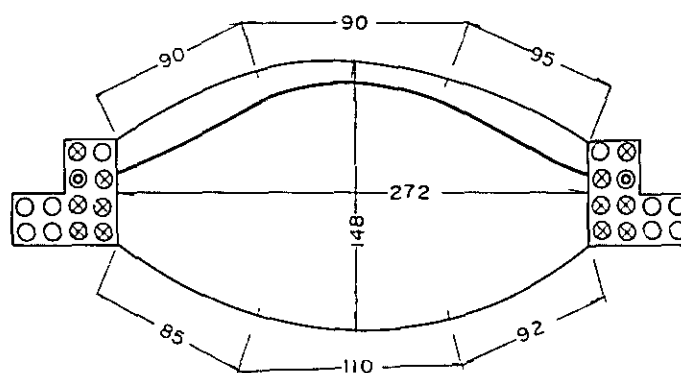

NO. 582 M.H.

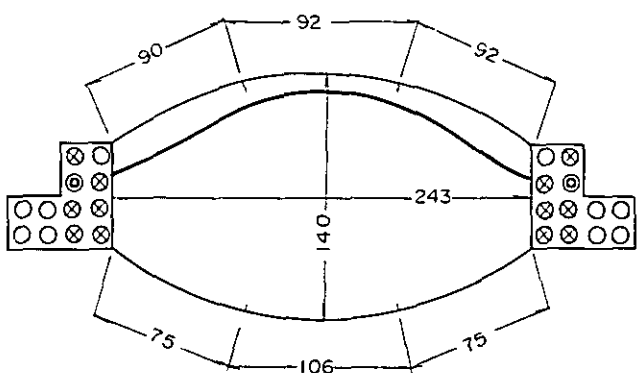

NO. 583 M.H.

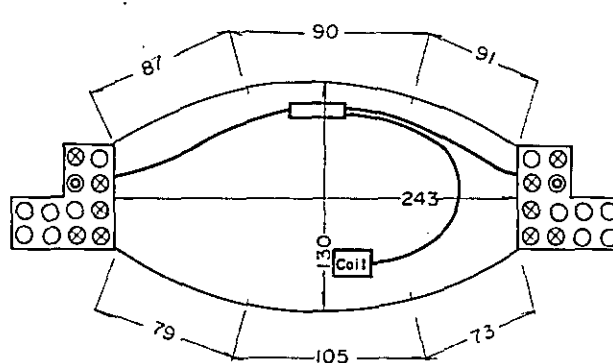

NO. 587 M.H.

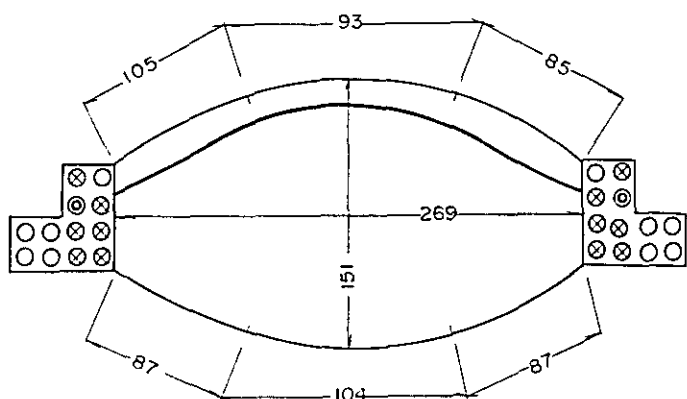

Unit : cm

Exchange	Mayangon
Drawing	Diagram of Cable Laying in Manhole
Drawing No.	III . 12 . 1/4

NO. 588MH

587 588 589

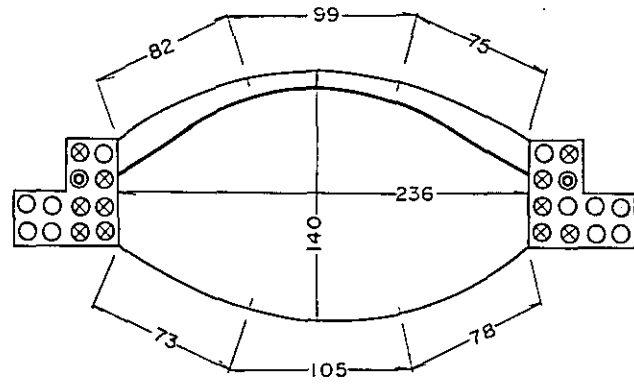

NO. 589MH

588 589 590

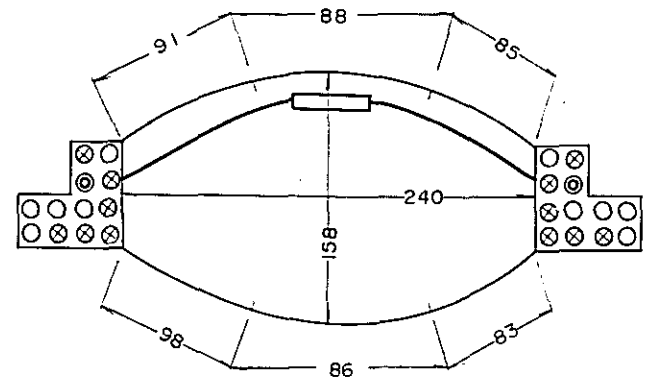

NO. 593MH

592 593 594

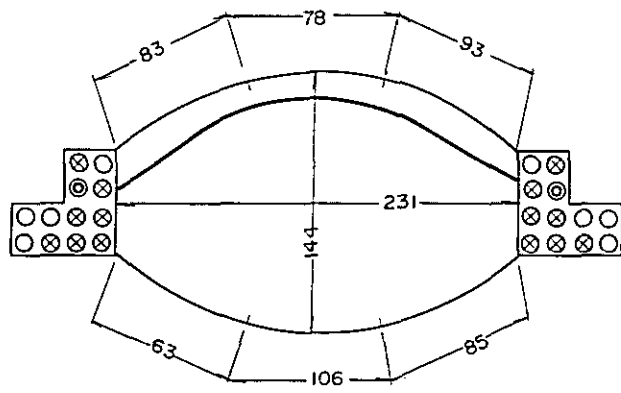

NO. 594MH

593 594 595

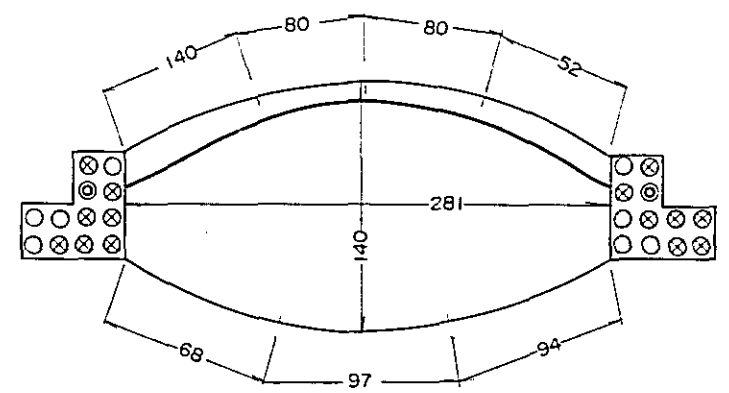

NO. 633MH

632 633 634

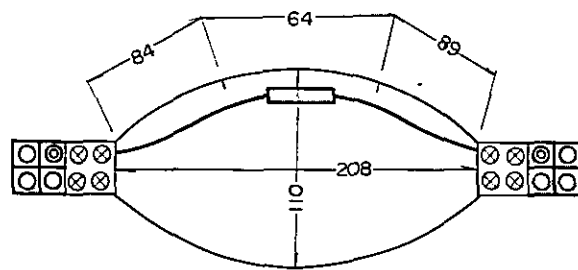

NO. 634MH

633 634 635

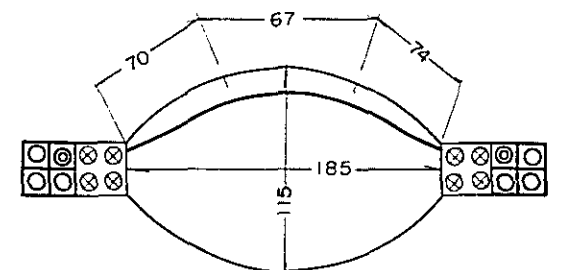

NO. 638MH

637 638 639

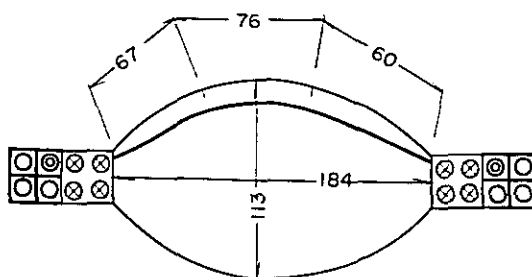

NO. 639MH

638 639 640

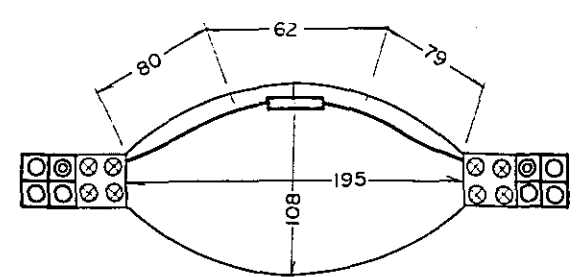

588-589-590

NO. 590MH

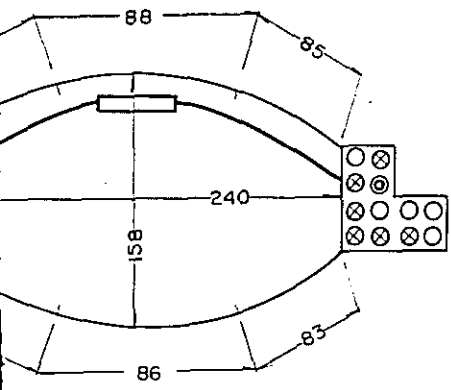

589-590-591

NO. 591MH

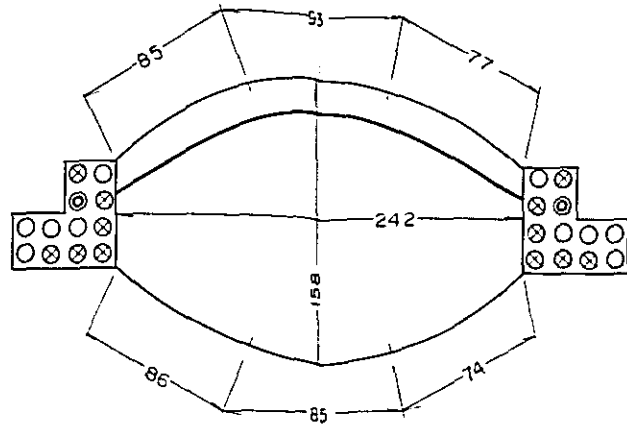

590-591-592

NO. 592MH

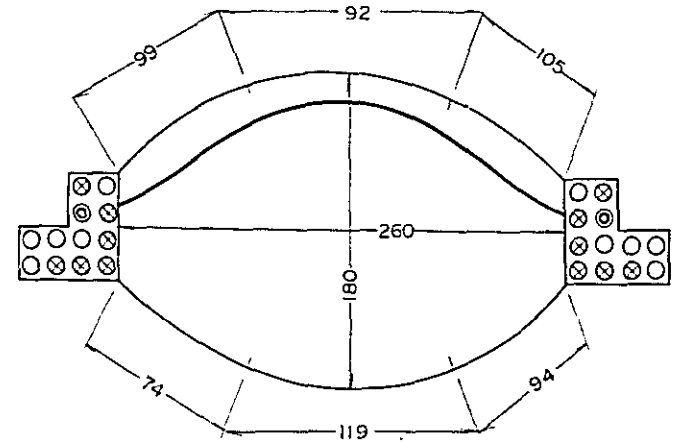

593-594-595

NO. 595MH

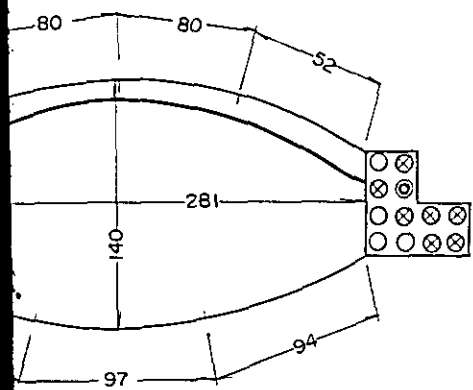

594-595-631

NO. 631MH

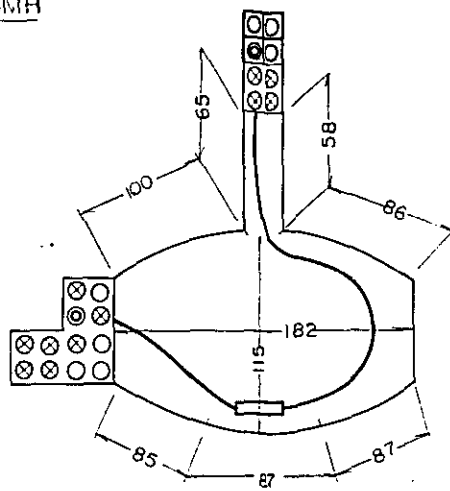

595-631-632

NO. 632MH

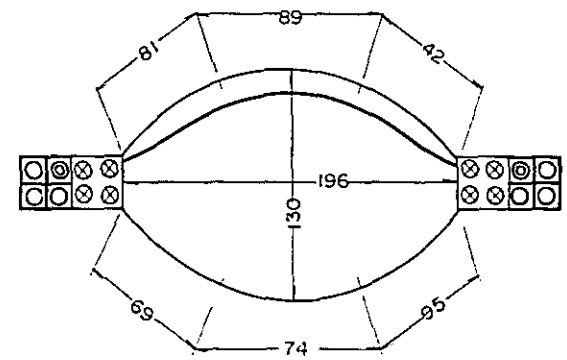

633-634-635

NO. 635MH

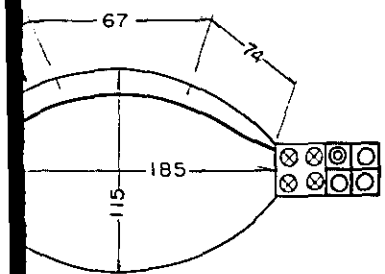

634-635-636

NO. 636MH

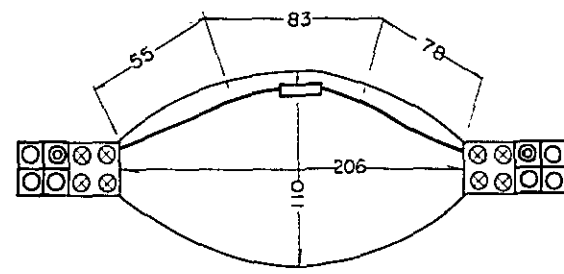

635-636-637

NO. 637MH

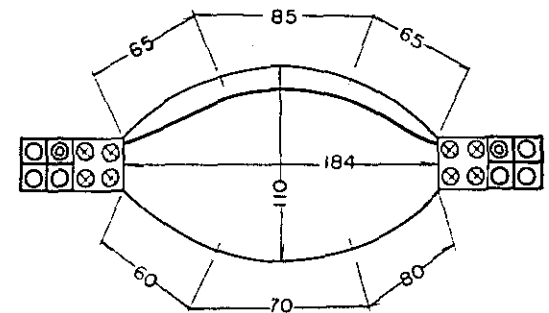

638-639-640

NO. 640MH

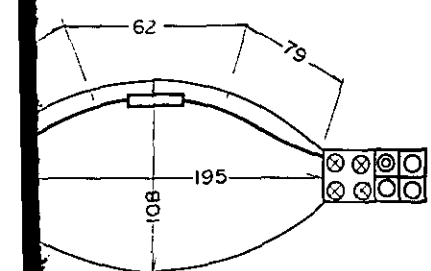

639-640-641

NO. 641MH

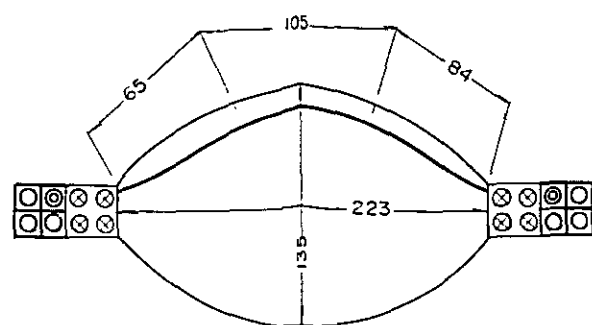

640-641-642

NO. 642MH

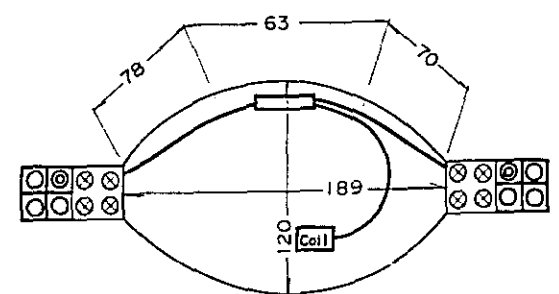

590 591

NO. 591MH

590 591 592

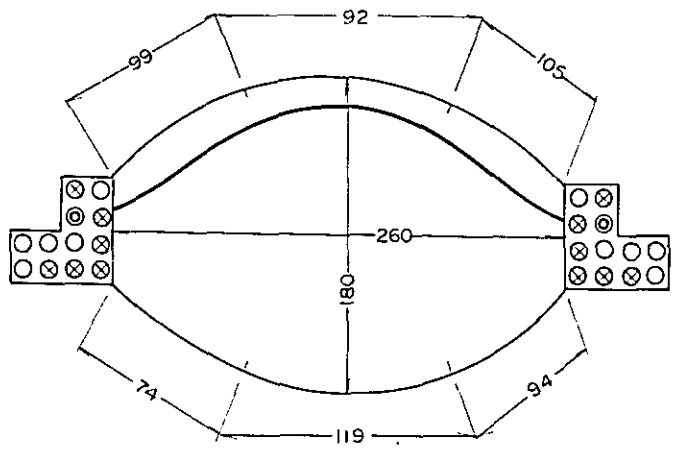

591 592 593

NO. 592MH

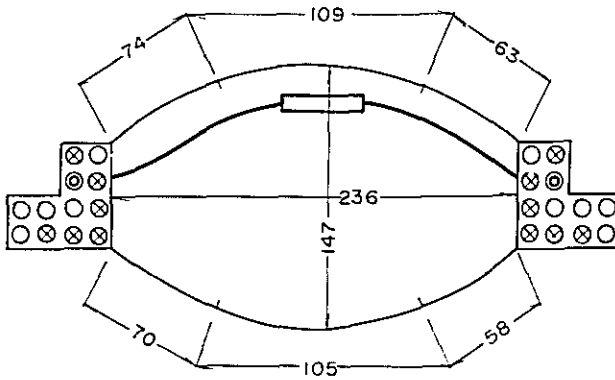

631 632

NO 631MH

631 632 633

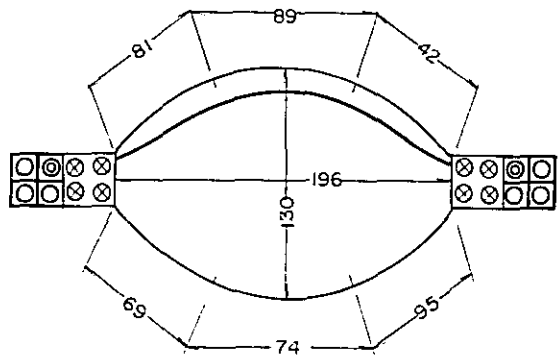

631 632 633

NO 632MH

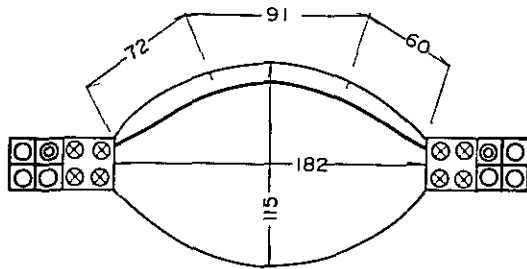

635 636

NO 636MH

635 636 637

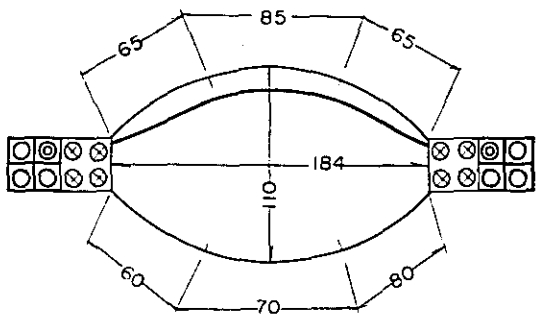

636 637 638

NO. 637MH

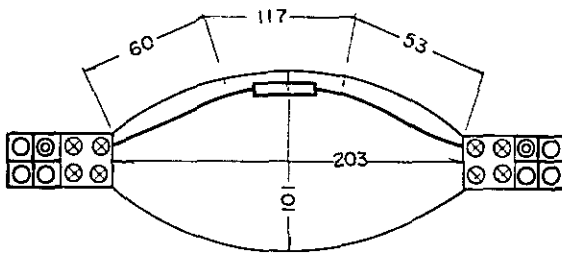

640 641

NO641MH

640 641 642

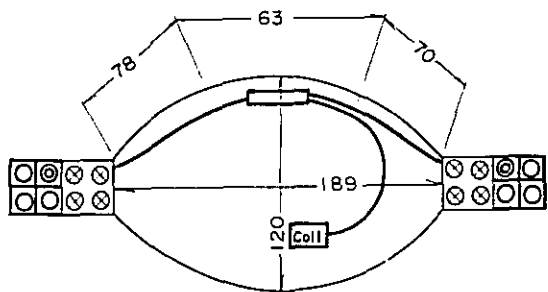

Unit : cm

Exchange	Mayangon
Drawing	Diagram of Cable Laying in Manhole
Drawing No.	III . 12. 2/4

NO. 642 M.H.

641-642-643

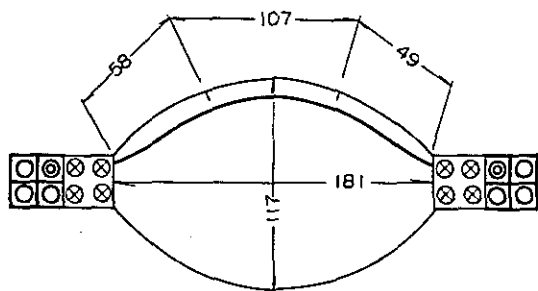

NO. 643 M.H.

642-643-644

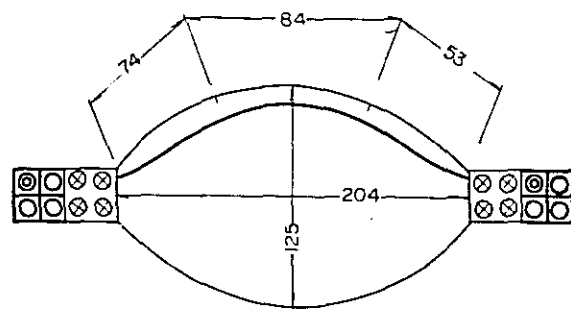

NO. 647 M.H.

646-647-648

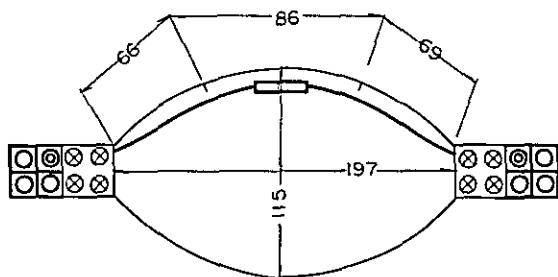

NO. 648 M.H.

647-648-649

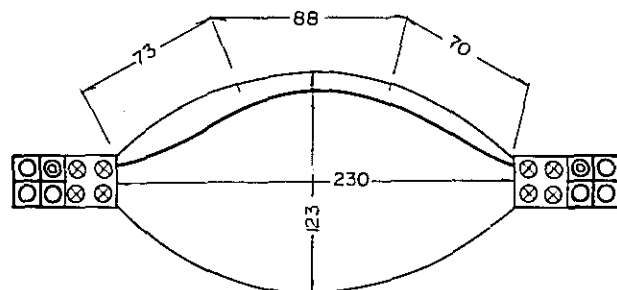

NO. 652 M.H.

651-652-653

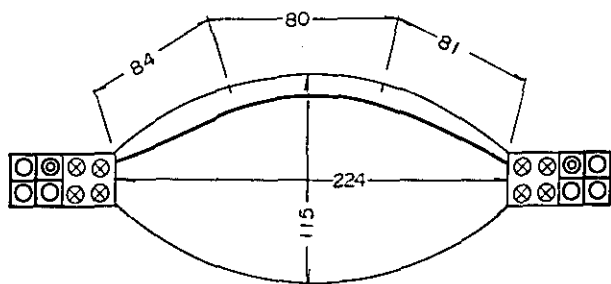

NO. 653 M.H.

652-653-654

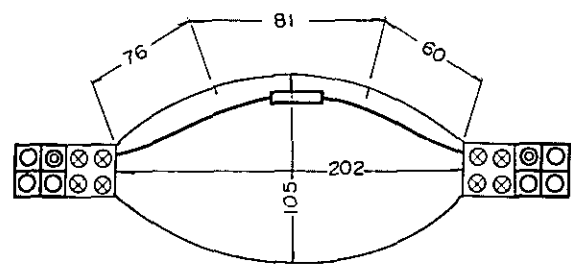

New M.H. NO. 4

To Hanthawaddy Ex. office → To Mayangon Ex. office

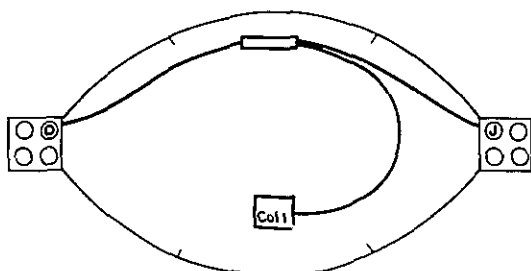

Existing L4 M.H.

To Hanthawaddy Ex. office → To Mayangon Ex. office

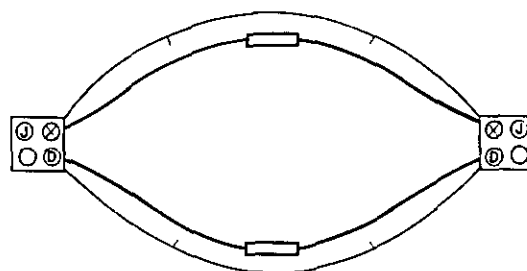

642-643-644

NO. 644 M.H.

643-644-645

NO. 645 M.H.

644-645-646

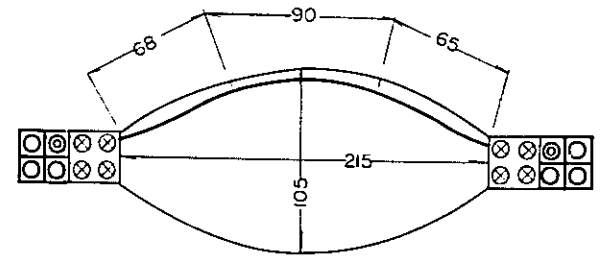
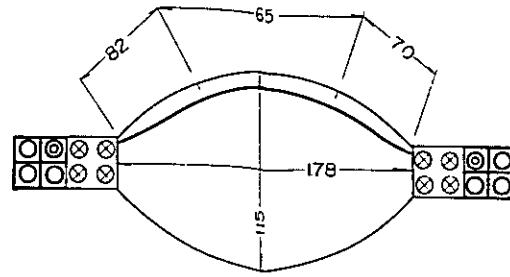
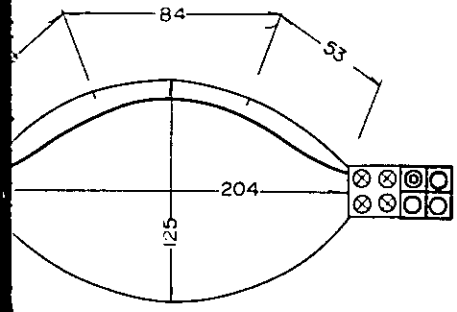

647-648-649

NO. 649 M.H.

648-649-650

NO. 650 M.H.

649-650-651

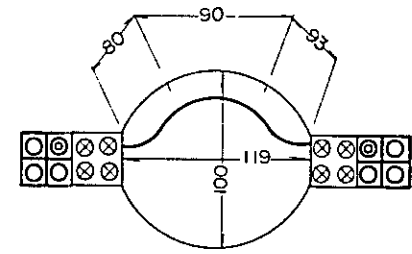
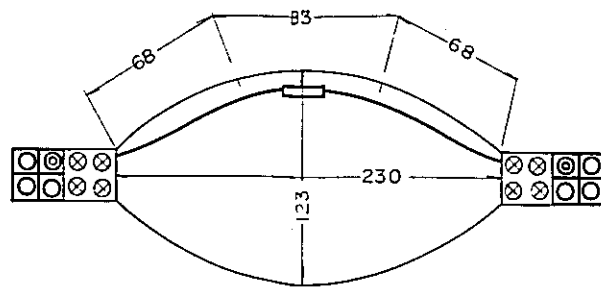
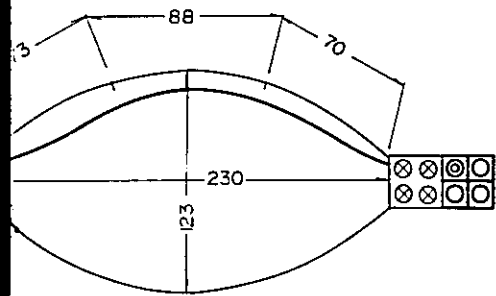

652-653-654

NO. 654 M.H.

653-654-655

NO. 655 M.H.

654-655 To Mayangon Ex. off

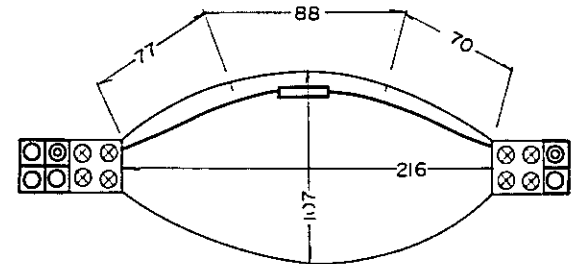
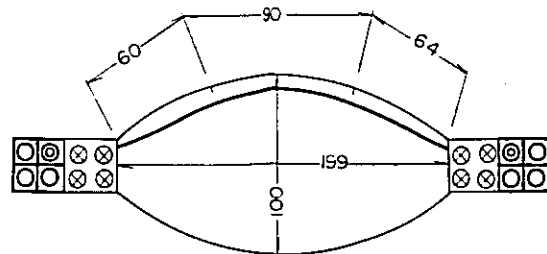
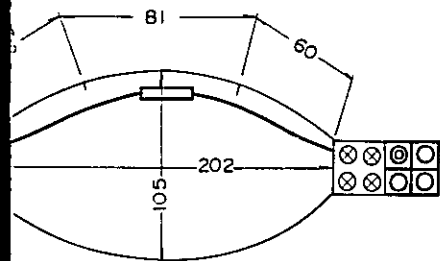

To Hanthawaddy Ex. office ← To Mayangon Ex. office

New M.H. NO.3

To Hanthawaddy Ex. office ← New M.H. No 2

New M.H. NO.2

New M.H. No 3 To Link Road To Mayangon Ex. off

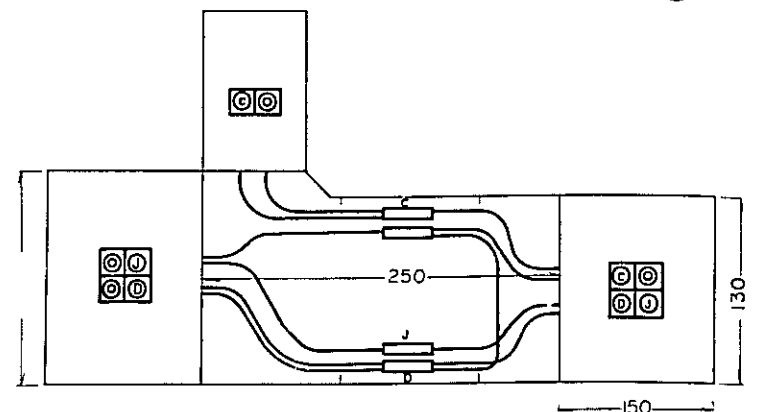
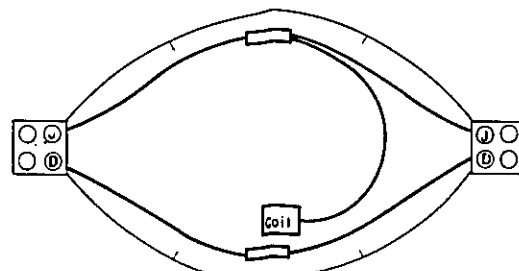
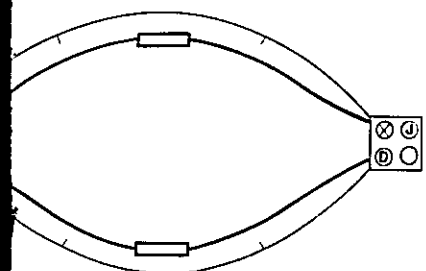

NO.645MH

644-645-646

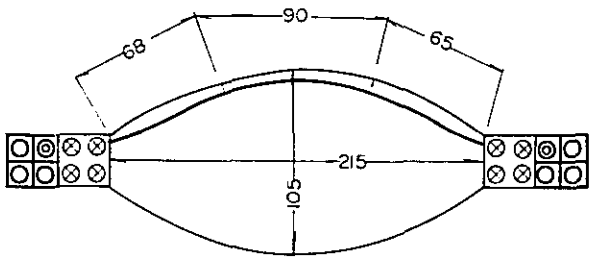

NO.646MH

645-646-647

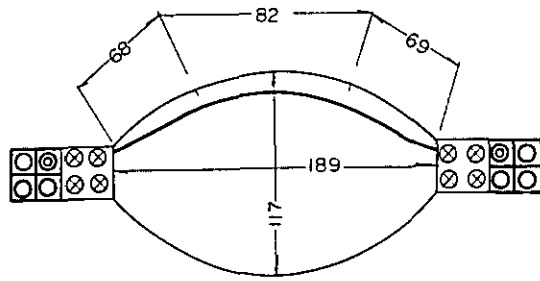

NO.650MH

649-650-651

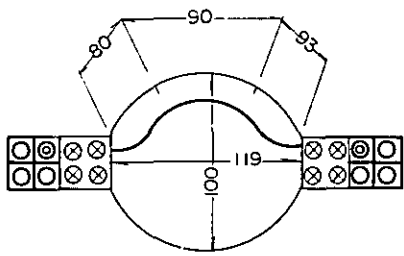

NO.651MH

650-651-652

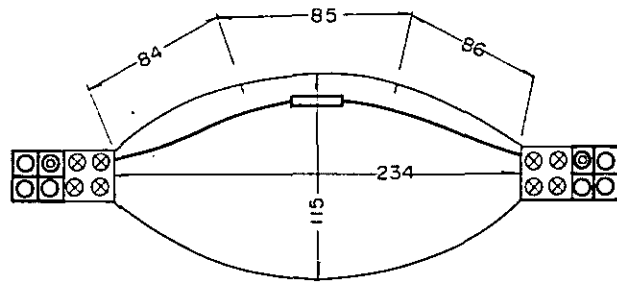

NO.655M.H.

654-655 To Mayangon Ex. off

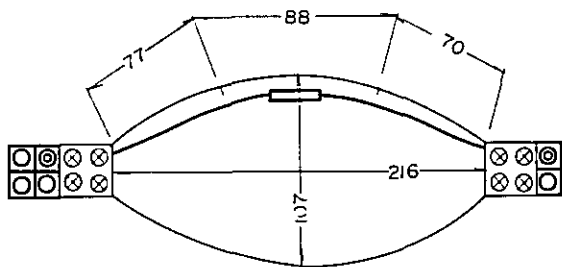

Existing L3 M.H.

To Hanthawaddy Ex. office To Mayangon Ex. office

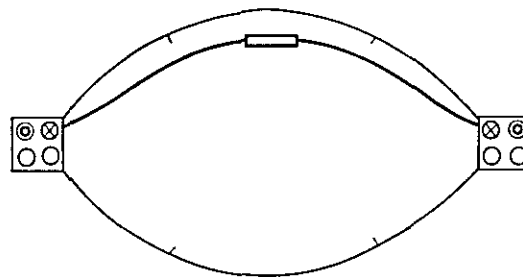

New MH. NO.2

New MH No 3 To Link Road To Mayangon Ex. off

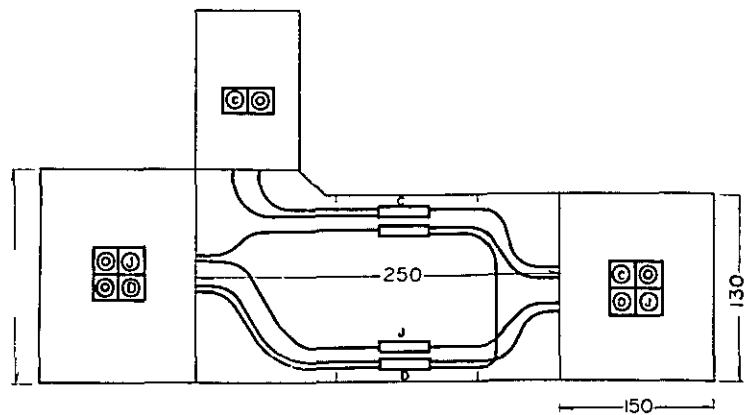

Unit : cm

Exchange	Mayangon
Drawing	Diagram of Cable Laying in Manhole
Drawing No.	III . 12. 3/4

New M.H. NO 1

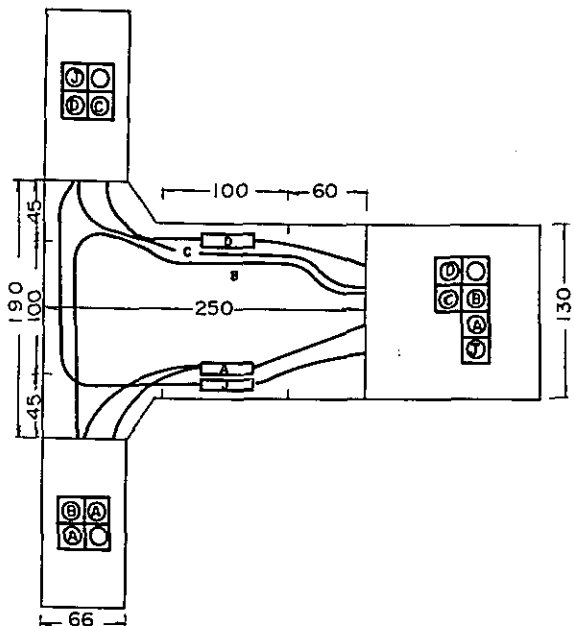

To Prom Road

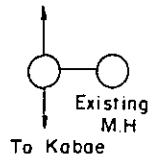

Existing M.H.
in front of the Mayangon Exchange Office

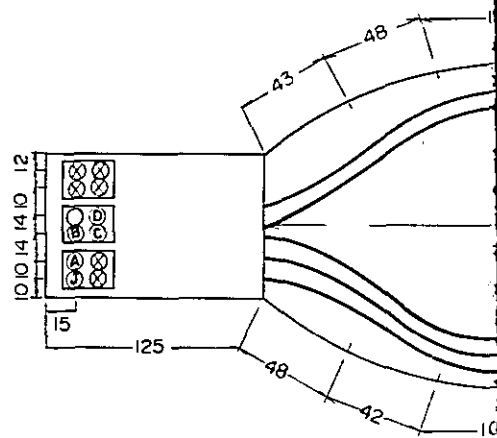

Mayangon. Exchange Office

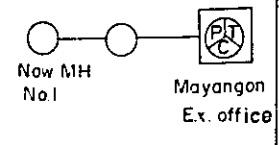
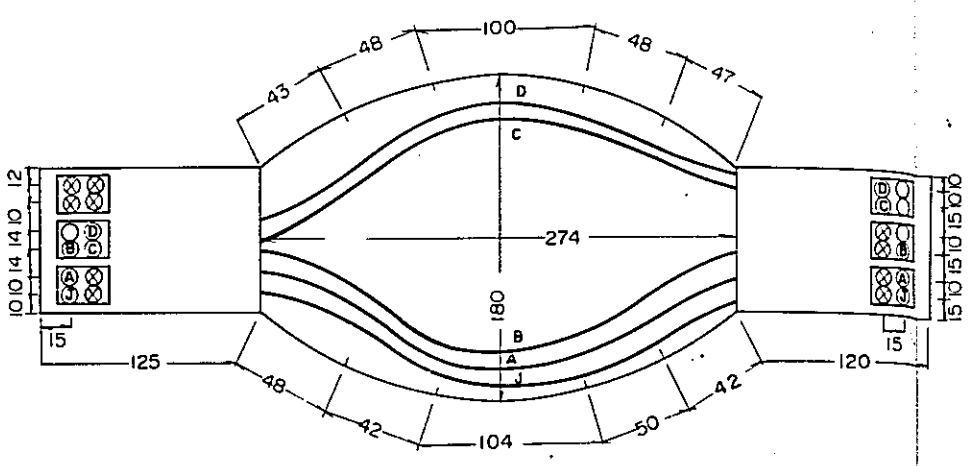



Mayangon
Ex. office

Unit : cm

Exchange	Mayangon
Drawing	Diagram of Cable Laying in Manhole
Drawing No.	III . 12 . 4/4

