

**The Project for  
Operation and Maintenance of  
The Sindhuli Road Phase 2**

**Implementation Report**

**On**

**The Technical Training on  
“Asphalt Concrete Mix Design and Quality Control in  
Pavement Construction”**

**March 2021**

**JICA Expert Team**

- Table of Contents -

- <b>1</b>	<b>Outline of the Training</b> .....	<b>1</b>
1.1	Background.....	1
1.2	Purposes and Goals of the Training .....	1
1.3	Participants (Trainers and Trainees).....	1
1.4	Selection of Trainees .....	2
1.5	Program.....	2
1.6	Mitigation Measures against COVID-19 .....	4
- <b>2</b>	<b>Reporting (Including Photo)</b> .....	<b>4</b>
2.1	Day 1 (14th Feb 2021).....	4
2.2	Day 2 (15th Feb 2021).....	6
2.3	Day 3 (16th Feb 2021).....	7
2.4	Day 4 (17th Feb 2021).....	9
2.5	Day 5 (18th Feb 2021).....	10
- <b>3</b>	<b>Evaluations of the Training</b> .....	<b>14</b>
3.1	Comments from Trainees .....	14
3.2	Comments from DOR.....	17
3.3	Comments from JICA Expert Team .....	18

ANNEX (Attachments)

1. Letters
2. Presentations (Mr. Bhat, Mr. Osti, Participants of two groups)
3. Sample of Certificate

## 1 Outline of the Training

### 1.1 Background

This Training Report has been prepared as per the program for Mix Design Training for DoR Engineers conducted from February 14 to 18, 2021 at the Central Laboratory of Department of Roads (DoR) at Chakupat, Lalitpur with a site visit on February 16 to the Sindhuli Road at Mulkot bends CH: 89+500 – 94+000, where the bituminous work was to be redone removing the defects occurred on the bituminous surface laid in the year 2011. The training was conducted as per the request of Development Cooperation Implementation Division (DCID) of DoR through their letter dated September 24, 2020. A Minutes of Meeting was prepared during the joint meeting between the SROM2 and DCID held on September 21, 2020 in this effect. Originally, the Training Program was planned during the 2<sup>nd</sup> week of November 2020, but was necessitated to be postponed due to wide spread prevalence of COVID pandemic in Kathmandu. It was the intention of DCID that the DoR engineers involved in the training would themselves perform different tests associated with Bituminous Mix Design.

### 1.2 Purposes and Goals of the Training

The main purpose of the training was to make the DoR Engineers involved in the construction and maintenance of bituminous pavements, aware of the importance of quality control aspects of the bituminous work through testing and setting the basic parameters of mixing materials and ultimately of the bituminous mix produced. It was expected that the Engineers themselves would carry out all operations regarding the techniques of mix design and would realize the importance of proper testing methods so that they could use this knowledge in the field as well as they would be able to interpret the results of testing involved in the mix design. They were also expected to learn about different types of bituminous mix plants and their advantages and disadvantages.

### 1.3 Participants (Trainers and Trainees)

The following table shows the name of participants with their respective organizations and post.

#### 1.3.1 Name of Trainees

Table 1.1 Name of Trainees

S.No.	Name	Organization	Post
1.	Ram Kumar Shrestha	QRDC	Sub-Engineer
2.	Madhav Prasad Adhikari	Bridge Sector - 2	Engineer
3.	Shambhu Prasad Acharya	Madan Bhandari Highway Project, Gaighat	Engineer
4.	Ashok Kumar Ray Yadav	Kathmandu Valley Road Improvement Project	Engineer
5.	Jay Ram Adhkari	Road Division, Bhaktapur	Engineer
6.	Aashika Pokharel	Road Division, Bharatpur	Engineer
7.	Dipak Kumar Jha	QRDC, DOR	Engineer
8.	Rabindra Shrestha	Sindhuli Road Project	Sub Engineer

9.	Salin Shakya	Road Division, Lalitpur	Engineer
10.	Sajeet Sharma	NSTRIPD, DOR	Engineer
11.	Shankar Khanal	QRDC, DOR	Engineer
12.	Sagar Karki Chhetri	SSDRP, DOR	Engineer
13.	Gitanjali Koirala	Sindhuli Road Project	Engineer

### 1.3.2 Name of Trainers

Table 1.2 Name of Trainers

S.No.	Name	Organization	Post
1.	Durga Osti	SRM2, JICA	Pavement Advisor
2.	Gagan Karnajit	QRDC, DOR	Lab officer
3.	Dasharath Thakuri	QRDC, DOR	Lab assistant
4.	Nawaraj Gautam	QRDC, DOR	Lab assistant

### 1.4 Selection of Trainees

For the selection of trainees the DCID requested the DoR and it nominated 15 participants to have the training, all but two of the participants could not attend the training due to their internal problems and only thirteen participants were able to attend as given above.

### 1.5 Program

Following table provides the details of the training program with description of activities together with time allocation and speaker/trainer.

## 1.5.1 Training Program Schedule

<b>Schedule of Training of "Asphalt Concrete Mix Design and Quality Control Aspects in Pavement Construction"</b>				
<b>Project : Training Program on Asphalt Concrete Mix Design and Quality Control Aspects in Pavement</b>		<b>Time</b>	<b>Speaker/Trainer</b>	
<b>2<sup>nd</sup> Fagun, 2077 14th Feb, 2021 (Day -1)</b>	Short inauguration and introduction of training program	10:15 AM- 10:25 AM	DG, DDG DCID, Mr. Arjun Jung Thapa	
	Objective of training and its importance	10:30 AM-10:40 AM	Director, QRDC, Dr. Bijaya Jaishi	
	Presentation on pavement condition of Sindhuli Road Project	10:40 AM-10:55 AM	Project Manager Mr. Surya Bahadur Bhat	
	Co-operation of SROM-2 and introduction of pavement expert	10:55 AM-11:00 AM	Project Coordinator/ JICA Expert SROM2, Mr. B.S Rana	
	Introduction to flexible/bitumen pavement Selection of binder Test of aggregates and binder Marshall procedure of mix design Determination of job mix formulae	11:00 AM-12 :30 PM	DO	
	Refreshment	12 :30 PM-1 : 15 PM		
	Test of Aggregates and Binder	1:15 PM-5:00 PM	GK, DT	
	<b>3<sup>rd</sup> Fagun, 2077 15th Feb, 2021 (Day -2)</b>	Interpretation of test results Determination of theoretical grading Selection of mix proportion and preparation of different mixes.	10:15 AM- 12 :30 PM	GK, DT
Refreshment		12 :30 PM-1 : 15 PM		
Marshall procedures and necessary tests of marshall specimens		1:15PM - 5:00PM	DO, GK, DT	
Field visit to Sindhuli -Bardibas Road				
<b>4<sup>th</sup> Fagun, 2077 16th Feb, 2021 (Day 3)</b>	8:00 AM	Move from QRDC gate	8 :00 AM-6:00 PM	DO, GK, NG
	8:00:00 AM To 8:30 AM	Way to Bhaktapur Plant		
	8:30 AM To 8:45 AM	Plant Inspection		
	8:45 AM To 12:00 PM	Way to Mulkot		
	12:00PM to 1:00 PM	Lunch at Mulkot		
	1:00 PM to 3:30 PM	Site inspection at Mulkot bend		
	3:30 PM	Move to Kathmandu		
<b>5<sup>th</sup> Fagun, 2077 17th Feb, 2021 (Day -4)</b>	Marshall stability, flow test and interpretation of test results	10:15AM-12:30PM	DO, GK	
	Refreshment	12 :30 PM-1 : 15 PM		
	Mix Design Calculations, Determination of job mix formulae of mix design and finalisation of Optimum Bitumen Content(OBC)	1:15PM - 5:00PM	DO, GK	
<b>6<sup>th</sup> Fagun, 2077 18th Feb, 2021 (Day -5)</b>	Presentation and submission of Mix Design Calculations and Discussion of Results	10:15 AM- 01 :15 AM	DO, GK	
	Refreshment	1 : 15 PM-2:00 PM		
	Group discussion	2:00 PM - 3:00 PM	DO	
	Closing ceremony with closing remarks	3:00 PM - 3:30 PM	DG, DOR DDG, DCID DOR Project Coordinator, SROM2 Director QRDC	
	Certificate Distribution	3:30 PM-4:30 PM		
Refreshment Break : 12 :30 PM ~ 1:15 PM				
NG: Mr. Nawaraj Gautam				
DO : Mr Durga Osti				
GK: Mr. Gagan Karnajit				
DT: Mr. Dashrath Thakuri				

## **1.6 Mitigation Measures against COVID-19**

As the COVID pandemic is still underway in the country and necessary precaution as per protocol was maintained during the whole training program. For this, necessary social distancing in the seating arrangement was maintained. All participants were provided with face shield and sanitization measures. All participants had to wear face mask mandatorily during the training as well as in the field visits. During the field visit it was assured that the trainees as well as other accompanying persons were to be seated on the vehicle with face masks and face shields maintain the required social distancing.

## **2 Reporting (Including Photo)**

### **2.1 Day 1 (14th Feb 2021)**

#### **2.1.1 Course**

On the first day of the training a short inauguration program was provided whereby the then DDG (He is now promoted to DG DoR on the second day of the training program) of DCID, Mr. Arjun Jung Thapa gave a concise introduction of the Training Program (with prior self-introduction of all present in the program) and announced the opening of the program. The Objectives and its importance were highlighted by Mr. Vijaya Jaisi the Director QRDC, DoR. Similarly, Pavement condition of Sindhuli Road was presented by the Project Manager Mr. Surya Bahadur Bhat. Co-operation of SROM2 and introduction of Pavement Advisor was done by the Project Coordinator of SROM 2 Mr. B. S. Rana. At this, the inauguration and formal program came to the end.

After the formal program the Pavement Advisor gave brief introduction of flexible/bituminous pavement, he explained the selection criteria for bitumen binder, tests requirement of aggregates and binder, methodology regarding the procedures of mix design as per Marshall criteria and finally determination of Job Mix Formula.

There was a break for refreshment for three quarters of an hour and then the trainees moved to laboratory for a practical demonstration of test of aggregates and binder. The trainees were assisted by DoR laboratory officer Mr. Gagan Karnajit, Mr. Dasharath Thakuri and Mr. Nawaraj Gautam both the laboratory technicians. Thus, the program of the first day was concluded.

The relevant photographs of the first day program are as follows:

2.1.2 Photographs



Opening of the training by DDG Arjun Jung Thapa



Presentation by PM Mr. Bhat



Remarks from SRM2 by Mr. Rana



Presentation by Mr. Osti



Explanation about lab equipment in the DOR laboratory



Practical experiment by participants

## 2.2 Day 2 (15th Feb 2021)

### 2.2.1 Course

The second day program was started with the interpretation of test results of previous day by the Pavement Advisor. The relevancy as well as the significance of the results were explained discussing with the trainees. After that a discussion on the determination of the theoretical gradings of the aggregates and the filler was carried out. The trainees suggested that the filler sometimes may not be sufficient and additional lime or cement to be added in the filler. It was well taken and appreciated by the Pavement Advisor.

After this, trial selection of mix proportion and preparation of mixes were discussed elaborately. In the second half of the program, after the refreshment break, the trainees went to the laboratory for specimen preparation and after that necessary tests for Marshall design were discussed. The trainees with the assistance of DoR laboratory personnel, prepared the specimens for bituminous mix design and testing cakes by compaction accordingly, by themselves. This was the end of second day program. The photographs of second day program depicting the activities are as follows:

### 2.2.2 Photographs



Explanation of result by Mr. Karnajit (QRDC Trainer)



Preparation of aggregate mix (weighing) by participants



Preparation of bituminous mix by heating and mixing

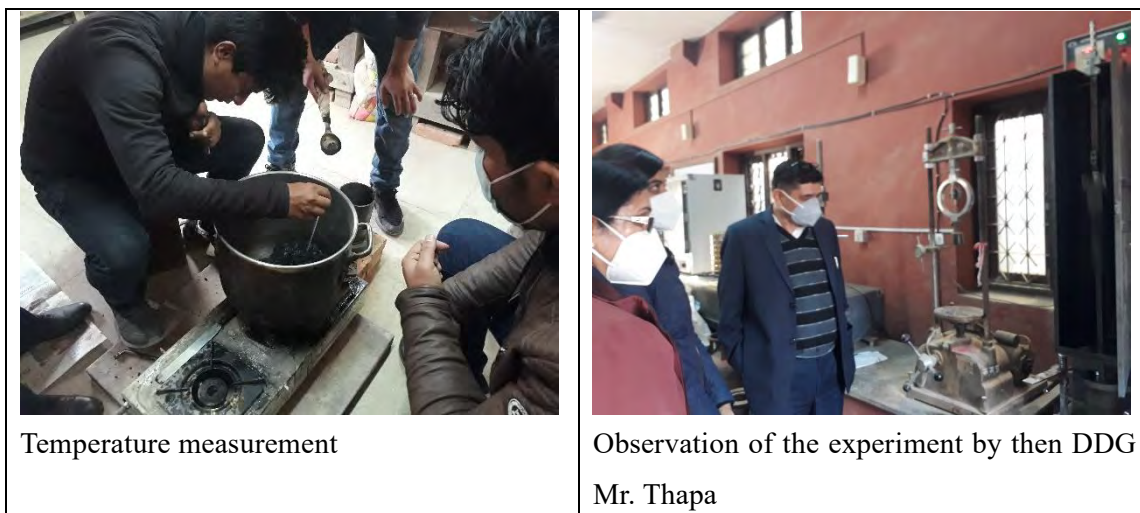

### 2.3 Day 3 (16th Feb 2021)

#### 2.3.1 Course

The third day program was set to be site visit by the trainees, the site visit was to be made along the Sindhuli – Bardibas Road up to Mulkot bends starting from QRDC gate of DoR at 8:00 AM. The site visiting team arrived at Bhaktapur where they were supposed to look/inspect into a Batch Mix Bituminous plant which was owned by the contractor M/S Samanantar who also was involved in the rectification of bituminous pavement at Mulkot bends of Sindhuli Road. They got a brief description of the plant by the personnel of the contractor for about a quarter of an hour. After the briefing the trainees with other accompanying persons started to Sindhuli Road at 8:45 AM and arrived at Mulkot around 12:00 Noon. The visiting team had Lunch at Mulkot and they moved to the work site at the Mulkot bends at 1:00 PM.

The site visit team inspected the works at the work site and had discussion with the Sindhuli Road Engineers regarding various aspects of bituminous overlay works. As per the pre-set program the team started at 3:30 PM from Mulkot and arrived at Kathmandu at around 7:00 PM thus concluded the third day program.

The photographs of the third day program are compiled as follows:

### 2.3.2 Photographs



Explanation at the asphalt plant in Bhaktapur



Asphalt plant of contractor in Bhaktapur



Bitumen stored in the plant

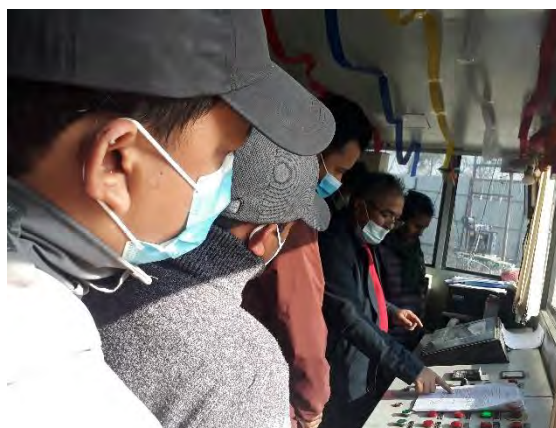

Display of contents of batch being explained by QRDC lab officer



Participants, trainer, SRM2 members ready to visit the site (Bhaktapur asphalt plant)



Participants observation at Mulkot bend (Explanation by Ms. Gitanjali Koirala)



A view of newly constructed pavement at the Mulkot hairpin bend

## 2.4 Day 4 (17th Feb 2021)

### 2.4.1 Course

The fourth day program was started with the testing of Marshall density, stability and flow test in the laboratory.

The results were discussed and interpreted by the Pavement Advisor and the DoR Laboratory personnel.

Following the refreshment break as per program it was set for mix design calculations and determination of mix formulae and finalization of optimum bitumen content (OBC). The trainees carried out these operations and arrived at the mix design contents of aggregates, fillers and the optimum bitumen content (OBC).

The fourth day activities are shown in the following photographs:

### 2.4.2 Photographs



Participants, trainer with core sample

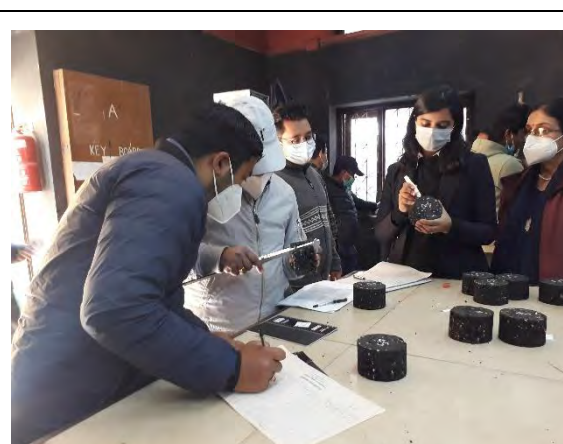

Measurement of core sample



Extraction of core content and different measurements by participants



Explanation of results by the lab officer Mr. Gagan Karnajit

## 2.5 Day 5 (18th Feb 2021)

### 2.5.1 Course

It was the final day of the training and a number of activities were to be carried out that day.

The trainees presented the mix design results with the detailed calculations as they have finally got after all operations of testing program.

After the presentation of results the trainees were given the concept of site quality control aspects such as:

- Load calibration of the Mixing Plant
- Extraction of bitumen from the sample and various sizes of aggregates
- Tests for Marshall Criteria
- Residual Stability after soaking the test sample in water bath at 60°C for 24 hours and test for stability.
  - The residual stability should not be less than 75% (that is loss in stability should not be greater than 25%)
- Core cutting and tests for thickness and required density (min 98%)

- Frequency of testing as per specification
- Smoothness in grades of finished surface

After a refreshment break the trainees presented and submitted their mix design calculations and the results were discussed. After the presentation a group discussion was carried on and the conclusion of the discussion of the result is summarized as:

- Although, the results were not very much precise as the operation was carried out by the trainees involving many persons but it was thought relevant for the learning purposes. The trainees realize the fact that they got the underlying importance of the tests. It was anticipated that they could carry out the test more accurately with more experience with the principle given in the training.
- It was the feeling of the trainees that as fillers in the stone dust used which is a present practice, more than often the fines are insufficient and they suggested to use cement or hydrated lime preferably the later in such cases. They would not like to add natural sand as filler as they had experienced that it weakened their mix.
- As VG grade of Bitumen is introduced in the country recently, a clear guideline should be worked out to use the different grades of VG bitumen considering the different temperature ranges in different parts of the country.

After the group discussion there was a closing ceremony of the program. The Director of QRDC Mr. Vijay Jaisi made a comment that he hoped the training program was useful for the DoR Engineers. He hoped that such trainings in other aspects of road construction would be useful for the DoR organization and he would further plan other trainings accordingly. DG DoR Mr. Arjun Jung Thapa further reinforced QRDC director on training and informed that DoR is initiating a training residential institute to be established in Gajuri for such training programs. Project Coordinator SROM2 Mr. B. S. Rana highlighted the training need for road safety and he promised that he would be willing to give training on road safety personally.

The last part of the program was certificate distribution and the DG DoR distributed the certificates to the trainees announced the closing oof the program.

The final day activities of the program are shown in the following photographers.

### 2.5.2 Photographs



Participants assembled for starting Specific gravity test (Explanation by lab officer)



Observation of specific gravity test of the core samples



Presentation about the training contents and results by a participant



Explanation of experiment results by the representative of group-2



Opinion from participants about the training program

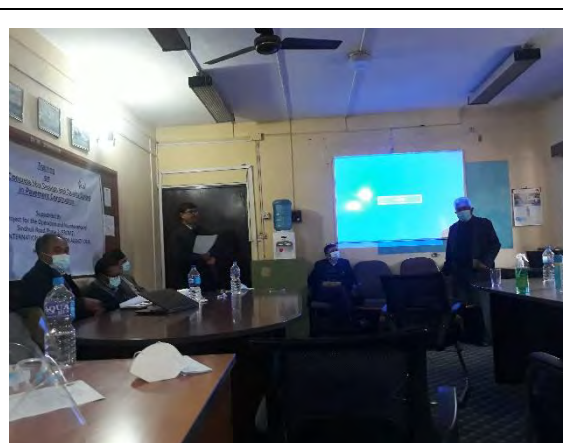

Remarks by Mr. Rana, SROM2 at the closing ceremony of the workshop



A snap of certificate distribution by DG Mr. Arjun Jung Thapa



Closing remarks and closing ceremony by DG Mr. Arjun Jung Thapa

### 2.5.3 Q&A Sessions and Discussions

There were a number of questions were posed during discussion session by the trainees. The outcome of the discussion session has been summarized above on the day five program.

### 3 Evaluations of the Training

Trainees expressed their views during the closing of the training. Trainees made two groups and one representative from each group presented whatever they learned during the training and also expressed their opinions about the training. (SROM2 as well as QRDC had prepared questionnaire for the evaluation of the training). The comments of the trainees were asked about the training program in the QRDC format and their individual answers have been filled and given in the following table.

#### 3.1 Comments from Trainees

There were two set of questionnaires for evaluation of training; the first set of questionnaires was prepared by the DoR QRDC and the second set was from SROM2 side. These two sets of questionnaires were distributed among the trainees for the evaluation of the training program. The formats of the questionnaires are given below in tables. These questionnaires were completed by the trainees and their evaluation has been attached.

##### 3.1.1 Questionnaire format (QRDC)HAD

S.No.	Session topic	Effectiveness of the session topics				Remarks
		Not Relevant	Relevant but slight useful	Useful	Very useful	
2	Introduction to flexible pavement / Bitumen Pavement Selection of Binder Test of aggregates and Binder Marshall Procedure of Mix design Determination of job mix formula					
3	Test of Aggregates and Binder					
4	Interpretation of test results Determination of theoretical Grading Selection of Mix proportion & Preparation of different mixes					
5	Marshall procedures and Necessary tests of Marshall specimens					
6	Field visit to Sindhuli Bardibas Road					
7	Marshall stability flow test and interpretation of test results					
8	Mix design calculations, Determination of job mix formulae of mix design and finalization of optimum Bitumen Content (OBC)					
9	Presentation and submission of mix design calculations and Discussion of Results					
Specific Comments on course contents:						

## 3.1.2 Filled Questionnaire by Trainees (QRDC)

Q.No.	Evaluation								
	2	3	4	5	6	7	8	9	Feedback
Trainee-01	2	3	3	3	2	NA	3	3	If the course is integrated with pavement design it is much fruitful.
Trainee-02	3	4	4	4	NA	NA	4	4	
Trainee-03	4	4	4	4	2	NA	4	3	
Trainee-04	4	4	3	3	2	NA	3	3	Diverse resource persons could impart more ideas. Trainings it held during shrawan, Bhadra, might cater more participants with more free time. Field works could be more useful.
Trainee-05	4	4	4	4	3	4	4	4	Should continue such training in future.
Trainee-06	3	4	4	4	2	2	4	4	Pavement design part can be included. This types of training should be continue to all technical person of DoR.
Trainee-07	4	4	3	4	3	4	4	4	
Trainee-08	3	4	4	4	3	NA	4	4	Overall good but the time limit need to be decreased by 1 day. The pavement design can also be introduced in
Trainee-09	4	4	4	3	2	4	3	4	There should be better to participation of higher/seniors of DoR during the discussion.
Trainee-10	2	2	3	3	1	3	3	3	
Trainee-11	3	4	3	3	2	3	4	4	
Trainee-12	4	4	4	4	3	4	4	4	
Trainee-13	3	3	3	3	2	3	3	3	

1 Not relevant

2 Relevant but slight useful

3 Useful

4 Very useful

NA No comment

### 3.1.3 Questionnaire form (SROM2)

**Participant Information**

Name \_\_\_\_\_

Position \_\_\_\_\_

Sex Male / Female      Age \_\_\_\_\_

1 Did you have enough opportunities to get direct experiences such as site-visits and practices in the course?

← Yes, very much	No, not at all →
<input type="checkbox"/> 4 <input type="checkbox"/> 3 <input type="checkbox"/> 2 <input type="checkbox"/> 1	

2 Was the quality/level of lecture good enough for you to understand clearly?

← Yes, very much	No, not at all →
<input type="checkbox"/> 4 <input type="checkbox"/> 3 <input type="checkbox"/> 2 <input type="checkbox"/> 1	

3 Which program was especially useful or interested in for you?

4 Is there any subject that were not covered through the course?

5 Did you have enough opportunities to get direct experiences such as site-visits and practices in the course?

← Yes, very much	No, not at all →
<input type="checkbox"/> 4 <input type="checkbox"/> 3 <input type="checkbox"/> 2 <input type="checkbox"/> 1	

6 Do you think the knowledge and experience you acquired through the course is useful for your future carrier?

← Yes, very much	No, not at all →
<input type="checkbox"/> 4 <input type="checkbox"/> 3 <input type="checkbox"/> 2 <input type="checkbox"/> 1	

7 How do you plan to utilize the knowledge for your carrier?

End

### 3.1.4 Filled Questionnaire by Trainees (SR0M2)

Q.No	Evaluation						
	1	2	3	4	5	6	7
Trainee-01	3	3	Interaction with lab equipment, method of test and data related with own design experiences.	It is best with the pavement design which incorporate & elaborated with the asphalt & its significance.	3	3	Interpretation of data test result of asphalt concrete provided by the lab/
Trainee-02	3	3	Marshall procedures / mix design.	Condition of pavement surface.	3	4	In field and lab section.
Trainee-03	3	2	Pavement design, concrete mix design slope stabilization.		3	4	
Trainee-04	3	3	Marshall mix design procedures, calculation & interpretation of results.	Execution of actual field work. Cause of remedies of pavement failures. Pre-treatment strategies for periodic maintenance.	3	3	Interpret lab reports & take necessary actions more carefully than before.
Trainee-05	3	3	Asphalt mix design		4	4	By using the knowledge in practical field.
Trainee-06	3	3	Marshall stability, Marshall flow value determination.	Pavement design.	4	4	Yes
Trainee-07	1	4	Laboratory jobs and design calculations.	Better if pavement design also included.	3	4	As it was partical training , we can always remember what we have done. So we can use and remember the procedure when we need.
Trainee-08	3	2	The lab works	The maintenance as well as repair of Asphalt Concrete.	3	4	By implementation of the knowledge gain in field and further enhanced knowledge by the study.
Trainee-09	2	4	Marshall mix design, procedure	It is enough for this time.	2	3	It always follow the mix design results before starting the asphalt mix design
Trainee-10	3	2	Presentation	Nothing	3	4	By the transfer of knowledge to follow engineers.
Trainee-11	3	2	Discussions, presentation	plant operation	3	3	Applying the knowledge in field
Trainee-12	4	3	Mix design calculations and its result interpretation		4	4	It is very much useful in the quality control part of AC Project.
Trainee-13	4	4	Mix design calculation & finding OBC	Material sampling	3	3	

1 Not relevant

2 Relevant but slight useful

3 Useful

4 Very useful

NA No comment

### 3.2 Comments from DOR

First of all, it is worthwhile to mention that the training program was conducted as per the desire of the DDG, QRDC, Mr. Arjun Jung Thapa, Mr. Thapa had mentioned during his opening address that the trainees themselves would carry out different tests required for the mix design basic parameters, and they would be doing the exercise for the mix design to get the required

parameters of asphalt mix design. During the training program most of the trainees would like to include the pavement design training as well. During the closing remarks the DG, DoR Mr. Arjun Jung Thapa informed that DoR is planning to have their own permanent residential training institute to be situated at Gajuri along the Prithvi Highway in Dhading District. The QRDC Director Mr. Vijaya Jaisi hoped that the trainees would utilize the knowledge they got in the training in their respective work places.

### **3.3 Comments from JICA Expert Team**

As evaluated by the trainees in two formats provided by QRDC and SRM 2, most of the Trainees mentioned that the training was useful for them. They were found to be doing required exercises during the program by discussing with each other.

The Coordinator Mr. Bindu Shamsheer Rana SRM2, hoped that such type of training in different fields of road construction may be arranged with consultation with JICA, if needed, and as proposed by DoR. Mr. Akhilesh K. Karna JICA Expert was happy to be a part of the training to support on logistics as required for the training. The Pavement Advisor found that trainees were keen to learn and were disciplined. The JICA Expert Team hopes that the training program was useful for their day-to-day work in the work fields.



Government of Nepal

Ministry of Physical Infrastructure & Transport  
Department of Roads

Tel : 977-015541686  
: 977-015541687  
Fax : 977-015542532  
Email : dorfcb@dor.gov.np

Kupandol, Jwagal-10

Development Cooperation Implementation Division

Ref. No: DLID-9/13/2077-78  
D.N.: 110

Date: September 24, 2020

To,  
Project Coordinator,  
JICA Expert Team,  
Sindhuli Road Operation and Maintenance Phase II

**Subject: Asphalt concrete mix design training**

Dear Sir,

We refer to the Minutes of Meeting dated September 21, 2020 regarding the captioned subject.

You are aware that DoR has allocated budget for overlay and rehabilitation of pavement in different section of Sindhuli Road. It has planned to carry out Asphalt Concrete laying works in October in Sindhuli Road. We want to organize a training on Asphalt Concrete mix design and its quality control at site to our Engineers while carrying out the actual work in site.

In this connection, we would like to request you to proceed for the said training program and make necessary arrangement.

Thanking you  
Sincerely yours,

(Arjun Jung Thapa)  
Deputy Director General

**CC:**

1. Director General, Department of Roads, Chakuptat, Lalitpur
2. Quality, Research and Development Center, Chakupat, Lalitpur
3. Project Manager, Suryabinayak - Dhulikhel, Dhulikhel - Sindhuli - Bardibas Road Project, Minbhawan, Kathmandu

Date: 22<sup>nd</sup> September, 2020

## Sub: Asphalt concrete mix design training

Meeting was held at DOR, DCID office which was chaired by Mr. Arjun Jung Thapa, DDG (DCID) on 21<sup>st</sup> of September 2020.

Discussion was focused on training of Mix design for DOR fifteen number of engineers which will be organized by SROM 2 under JICA Program as requested by DOR-DCID (Development Cooperation and infrastructure Division), DCID is in the process for request letter to SROM 2 to conduct training program as requested by SROM 2. Following person were attended the meeting at DOR, DCID office.

- 1) Mr. Arjun Jung Thapa, DDG (DCID)
- 2) Mr. Rupak Raj Bhandari, S DE (DCID)
- 3) Mr. Surya Bahadur Bhat, PM (Sindhuli Road)
- 4) Mr. Babu Ram Sapkota, SDE (Central Lab, DOR)
- 5) Mr. Gagan Karanjit, Lab officer (Central Lab, DOR)
- 6) Mr. Bindu S Rana, Project Coordinator (SROM 2)
- 7) Mr. Durga Prasad Osti, Pavement Advisor (SROM 2)

### Discussion and understanding

- 1) Number of participants will be maximum 15.
- 2) Duration of training initially proposed for four days but due to lab works related with mix design training, total number of day may require five days (this is suggested by Central lab, DOR).
- 3) Training period is recommended from 12<sup>th</sup> of October to 16<sup>th</sup> of October, keeping in view of Dashian Festival.
- 4) Material samples for the asphalt mix design shall be provided by ongoing Asphalt concrete pavement work site at Sec. IV (near Bhakundbesi) from Sindhuli Road.
- 5) It was agreed that pavement advisor Mr. Osti and central lab officer Mr. Gagan will work jointly to finalize necessary preparation work required for training.
- 6) Venue for training for participants will be Central lab conference hall.
- 7) DOR, central lab shall provide necessary chemicals and other materials required for training.
- 8) It was decided in the meeting that the coarse aggregates, filler and binder as required for the mix design shall be used from the source as explained above. The basic parameters of the test results of the coarse aggregates and filler shall be used from the results of the mix design of contractor, however the binder as proposed VG30 grade of



bitumen sampled from Sindhuli Road Contractor will be tested at the Central laboratory to establish the basic parameters of the binder.

- 9) When all samples will be ready Mr. Osti will explain the trainees the procedures required for testing. He will also explain the various types of asphalt mixes and their uses in the pavement works.
- 10) Mr. Karanjit the Laboratory Officer of the central lab along with his team will be fully engaged during the training program and Mr. Osti will supervise the ongoing testing operation from time to time.
- 11) It was decided that each trainee will exercise for each type of testing and finally the mix design will be carried out in groups, in the process, Mr. Karanjit will assist them as and when required.
- 12) At the end of the training the trainees in groups will present the results of the tests and suggest the job mix formula (JMF) for the mix design.

#### **Precaution during training due to COVID 19**

Members in the meeting agreed to follow WHO norms during training program as suggested by project coordinator SROM 2 as follows:

- 1) All participants shall use face mask, hand sanitizer and face shield during entire training period and site visit.
- 2) DOR, Central lab during training period shall arrange to follow social distance and other guidelines required due to COVID 19

Tourist Bus with seating capacity for 30 number of person is recommended in view to follow social distance (Double the capacity of the passengers) as Govt regulation to maintain social distance.



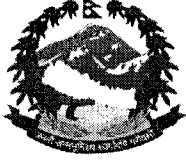

Government of Nepal  
Ministry of Physical Infrastructure & Transport  
**Department of Roads**  
**Quality Research and Development Centre (QRDC)**  
Chakrapati, Lalitpur

Letter No: 077/78  
Ref.No:- 350

Date: 06-Apr 2021

**Mr. Hiroki SHINKAI**  
**Chief Advisor / JICA Expert**  
**The Project for the Operation and Maintenance of Sindhuli Road Phase-2 (SRM-2)**

**Subject: Appreciation to JICA-Japan**

Dear Sir,

We would like to express our sincere appreciation to you and the JICA under the project for the operation and Maintenance of Sindhuli Road Phase-2 (SRM-2) for organizing such a valued Lab Training titled “**Training on Asphalt Concrete Mix Design and Quality Control Aspects in Pavement Training**” from 14<sup>th</sup> to 18<sup>th</sup> February 2021 at DoR Central laboratory (4 Days at DoR Central Laboratory and 1 day site visit to Sindhuli Road upto Mulkot Asphalt Concrete Construction Site of DOR).

The captioned training was really fruitful and result oriented for the practical application in our upcoming development projects. We highly appreciate JICA Japan for their support to our organization since long. Especially, we are so happy for receiving positive and encouraging feedback from our Engineers in response to this training session organised from 14th to 18th February, 2021.

Thank you once again for your continuous support.

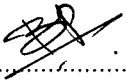
  
.....  
(Dr Bijaya Jaishi)  
Director, QRDC

**Dr. Bijaya Jaishi**  
CC: Director

1. Development Cooperation Implementation Division (DCID), DOR
2. Suryabinayak - Dhulikhel, Dhulikhel – Sindhuli – Bardibas Road Project, Min Bhavan
3. JICA Nepal Office



**MIX DESIGN TRAINING  
for DoR ENGINEERS**

**FEBRUARY 14~18 2021**

**Durga Prasad Osti**

## Components of flexible pavement.

1. Soil Subgrade.
2. Sub Base Course.
3. Base Course.
4. Surface Course.

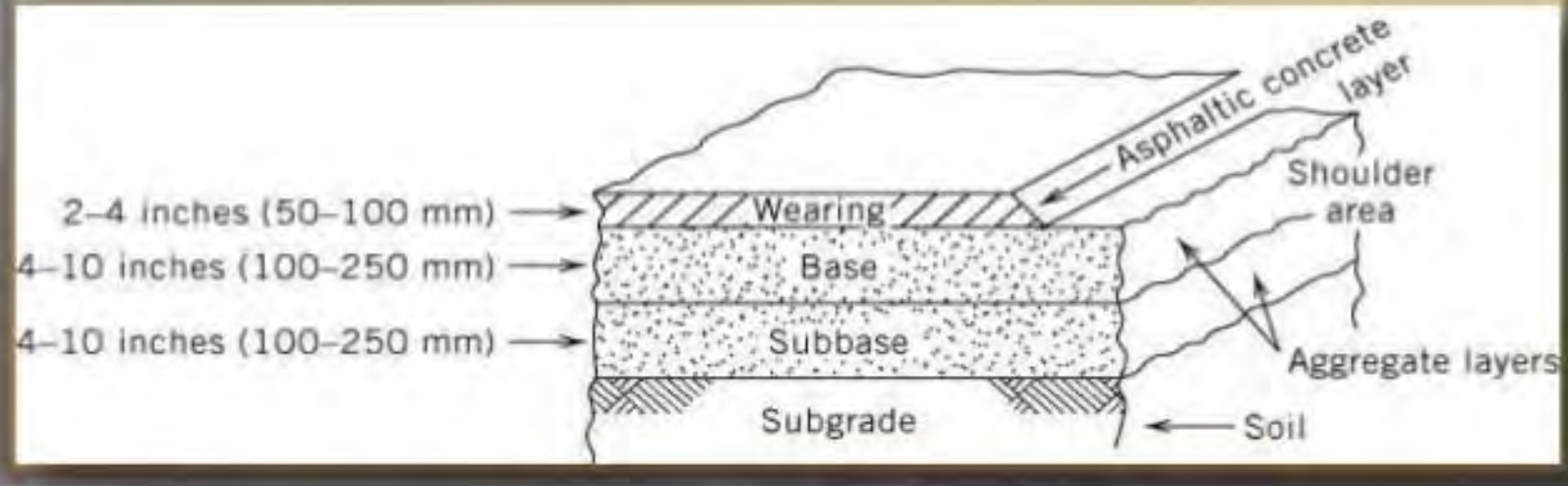

# Flexible Pavement Section

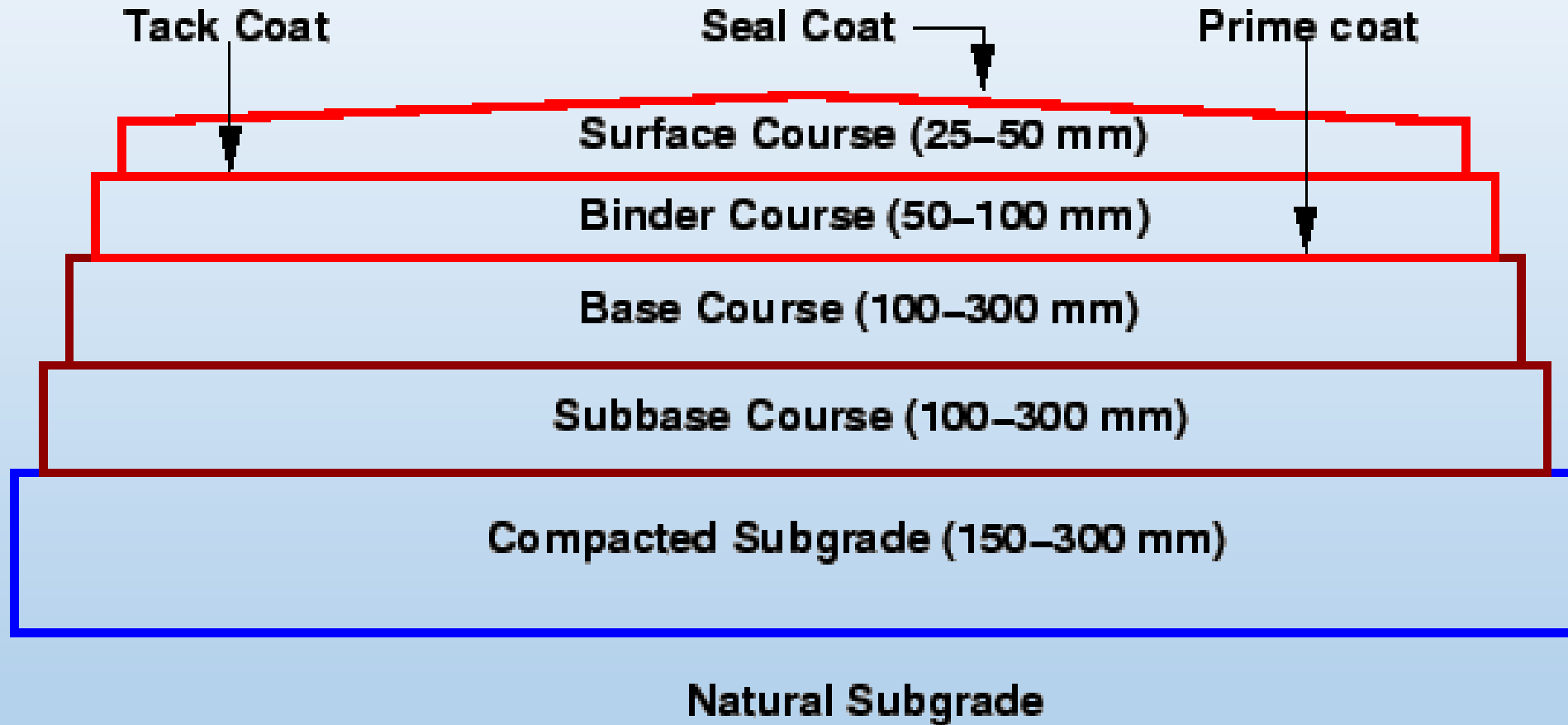

- A typical flexible pavement consists of a bituminous surface course over base course and sub-base course.
- The surface course may consist of one or more bituminous or Hot Mix Asphalt (HMA), Dense Bound Macadam (DBM), or Hot Rolled Asphalt (HRA) layers .
- These pavements have negligible flexure strength and hence undergo deformation under the action of loads.
- The structural capacity of flexible pavements is attained by the combined action of the different layers of the pavement.
- The subgrade layer is responsible for transferring the load from the above layers to the ground.
- Flexible pavements are designed in such a way that the load that reaches the subgrade does not exceed the bearing capacity of the subgrade soil.

- Consequently, the thicknesses of the layers above the subgrade vary depending upon strength of soil affecting the cost of a pavement to be constructed.
- The subgrade is generally compacted at 93%-95% in accordance with BS heavy compaction at optimum moisture content.
- If subgrade soil strength is weak ( $\text{CBR} < 5\%$ ) a capping layer of suitable thickness is used the capping layer should have CBR value 15-30%
- The sub-base layer is generally natural pit gravel or crushed rock with CBR value above 35% compacted in accordance with BS heavy compaction at optimum moisture content. The minimum field density of the sub-base should be 95% - 98% as per specification
- Base course is generally crushed rock with CBR value above 80% in accordance with BS heavy compaction at optimum moisture content. The minimum field density of the base course should be 98% as per specification

- Aggregates: Coarse Aggregates : Crushed Rocks graded as per Specifications
- Fillers: Stone Dust, Sand, Cement Hydrated Lime etc.
- Binder: Bitumen:
  - Penetration Grade, 80/100, 60/70
  - Viscosity Grade (VG) VG10, VG20, VG30 and VG40
  - Performance Grade: PG without or with polymer mix

# Performance Grade of Bitumen and use point

**Bitumen is a thermoplastic material and its stiffness is dependent on temperature.**

**The temperature-vs-stiffness relationship of bitumen is dependent on the source of crude oil and the method of refining.**

<b>VG-10 BITUMEN</b>	VG-10 is widely used in spraying applications such as surface-dressing and paving <b>in very cold climate</b> in lieu of <b>80/100 Penetration grade</b> . It is also used to manufacture Bitumen Emulsion and Modified Bitumen products.
<b>VG-20 BITUMEN</b>	VG-20 is used for paving in <b>cold climate &amp; high altitude</b> regions
<b>VG-30 BITUMEN</b>	VG-30 is <b>primarily used to construct extra heavy duty Bitumen</b> pavements that need to endure substantial traffic loads. It can be used in lieu of <b>60/70 Penetration grade</b> .
<b>VG-40 BITUMEN</b>	VG-40 is used in <b>highly stressed areas such as intersections</b> , near toll booths and truck parking lots in lieu of <b>30/40 Penetration grade</b> . Due to its higher viscosity, stiffer Bitumen mixes can be produced to improve resistance to shoving and other problems associated <b>with higher temperature and heavy traffic loads</b> .

Characteristics	VG 10	VG 20	VG 30	VG 40
Absolute Viscosity, 60°C, poises, min	800	1600	2400	3200
Kinematic Viscosity, 135°C, CST, min	250	300	350	400
Flash point, C, min	220	220	220	220
Solubility in trichloroethylene, %, min	99.0	99.0	99.0	99.0
Penetration at 25°C	80~100	60~80	50~70	40~60
Softening point, C, min	40	45	47	50
Viscosity ratio at 60°C, max	4.0	4.0	4.0	4.0
Ductility at 25°C, cm, min, after thin film over test	75	50	40	25

- PG grade of bitumen is not in general practice in Nepal
  - Tribhuvan International Airport has used some PG 70-10 recently by producing mixing with polymer (generally above 4% polymer) (used VG10 IOC bitumen and SINOPEC 60-80 penetration grade) ( VG10 + 4.13% polymer and 60-80 + 4.10% polymer determined after testing outside Nepal)
  - Penetration Grade of Bitumen is Replaced by Viscosity Grade (VG) of bitumen (IS:73)
  - It is included in the existing specification and is available in this region
  - The Choices of VG grades of bitumen depends upon the average maximum 7 day air temperature for a period not less than 5 years:
  - The range of temperatures are as follows:

VG10	<30°C
VG20	30-38°C
VG30	38-45°C
VG40	>45°C
- e. g. Kathmandu 34°C VG20, Terai and River Valleys VG30, High Mountains VG10

# Flexible / Bituminous Pavement (Site works)

1. Cleaning work

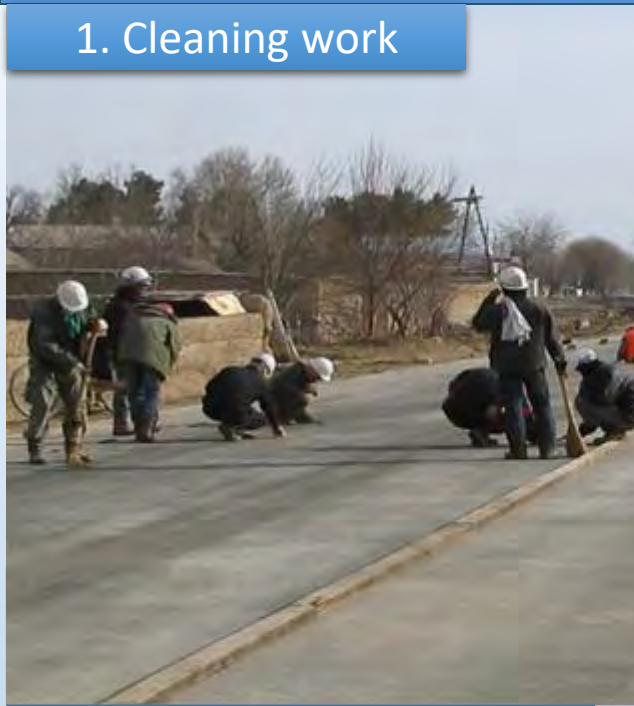

2. Tack coat



3. Spreading by Asphalt paver



4. Compaction



Bituminous Mix

# Bituminous Pavement / Working Sequences

**Step.1** Bituminous mixture shall be mixed using **Asphalt plants** with the production rate required to meet the construction program

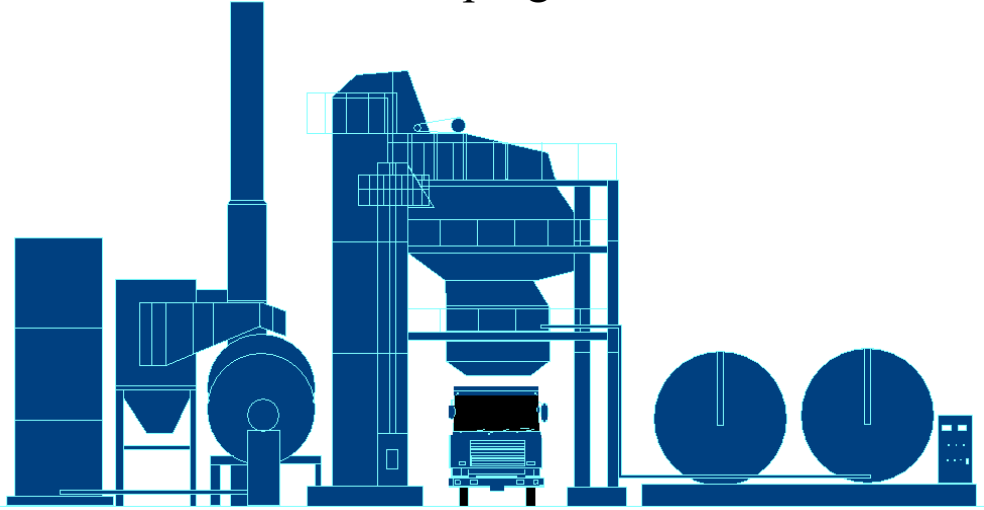

**Step.2** The mixture shall be transported from the Asphalt plant to the working site.

**Step.3** Immediately after cleaning the surface, **Tack coat/Prime coat** material shall be applied by distributor



**Step. 4** The mixture shall be **spread by asphalt paver**, spreading and finishing will be conducted in the correct elevation and grade.

**Step.5** Immediately after each layer has been spread and shaped satisfactorily, each layer shall be thoroughly compacted with **suitable and adequate compaction equipment**.

# Bitumen Mix Plant Characteristic and use point (Batch Plant vs Drum Plant )

## COMPONENTS OF AN ASPHALT CONCRETE BATCH PLANT

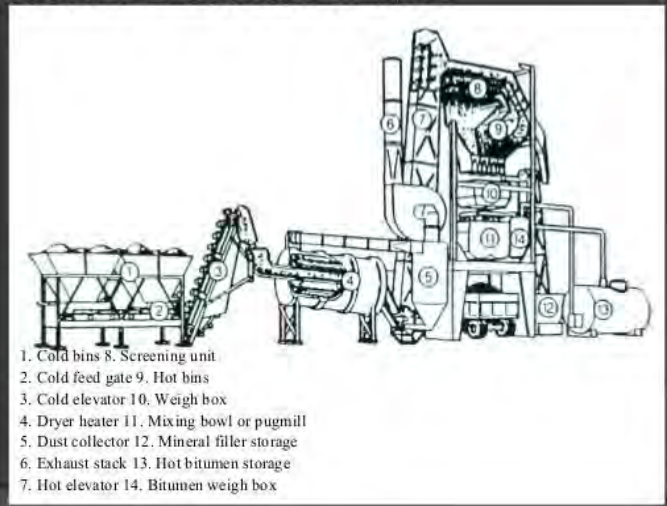

Charac teristic s	Each material is weighed in a measuring tank every batch and mixed with a mixer
Advant age	<b>Quality control is easy</b> because the material is sieved by screen and then weighed
Disadvan tage	<ol style="list-style-type: none"> <li>1. Production capacity is smaller than drum plant</li> <li>2. Plant equipment system is complicated</li> </ol>

## ASPHLT CONCRETE DRUM PLANT

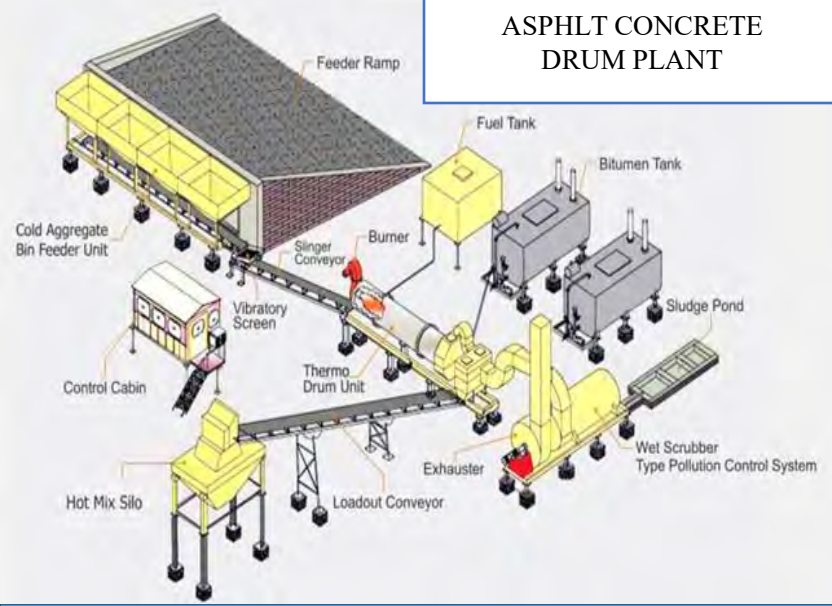

Charact eristics	Mix each material at a set flow rate by Cold aggregate bin feeder
Advanta ge	<ol style="list-style-type: none"> <li>1. Plant equipment is simpler than batch plant</li> <li>2. The production capacity is larger than batch plants</li> </ol>
Disadvan tage	<ol style="list-style-type: none"> <li>1. <b>Asphalt mixture without sieving</b></li> <li>2. <b>The quality of asphalt mixtures depends on the quality of aggregate and sand</b></li> </ol>

# MIX DESIGN

## Classification of Asphalt Mix

- Dense Graded Mix
  - ✓ a well-distributed aggregate gradation: commonly used for Binding & wearing Layer, Designed By Superpave, Marshall and Hveem Method; Generally up to 5 % air void
- Open Graded Mix (Porous) to drain water
  - ✓ have a large volume of air voids (typically 18 to 22 percent)
- Gap Graded Mix (Stone Matrix Asphalt)
  - ✓ a high-coarse aggregate content (typically 70 to 80 percent)
  - ✓ a high asphalt content (typically more than 6 percent); a high-filler content (approximately 10 percent by weight)
- Stone Mastic Asphalt (SMA)
  - ✓ high quality stones  $LAA \leq 20\%$ ,
  - ✓ binder content  $>6\%$  for good texture on surface



Stone Mastic Asphalt

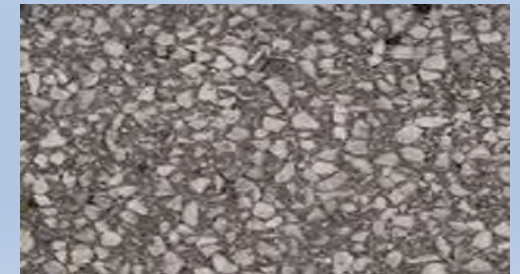

Gap Graded Mix

## Mix Properties/ Causes of Failure

### 1. Resistance to Permanent Deformation

- Unrecoverable deformation by repeated loads –Rutting ( underlying layers failure/ mix stability)
- Need correction in binder and gradation to increase internal friction

### 2. Fatigue Resistance ( Alligator Cracking )

- Improper pavement thickness, air voids & binder properties

### 3. Low temperature Cracking

- Thermal stress  $>$  tensile strength-results- transverse crack
- Proper choice of binder, Increase in dust

### 4. Moisture resistance (stripping failure)

- improper air voids, TSR –use additives

### 5. Durability- proper design- dense graded, thickness, compaction -Air voids less than 5%

### 6. Skid resistance –rough texture by aggregate

### 7. Workability- maintain temperature

### Mix Design

- to determine the combination of asphalt cement and aggregate that will give long-lasting performance as part of the pavement structure.
- optimum asphalt to ensure a durable pavement
- sufficient mix stability to satisfy the demands of traffic without distortion or displacement
- sufficient air voids in the total compacted mix to allow for a slight amount of additional compaction under traffic loading
- sufficient workability to permit efficient placement of the mix without segregation
- aggregate texture and hardness to provide sufficient skid resistance

The final goal of mix design is to select a unique design binder content that will achieve a balance among of the desired properties (durability, impermeability, strength, stability, stiffness, flexibility, fatigue resistance and workability ) with specific properties as per site condition.

## I. Marshall mix design and History

The basic concepts of the Marshall mix design method were originally developed by Bruce Marshall of the Mississippi Highway Department around 1939 and then refined by the U.S. Army. Currently, the Marshall method is used in some capacity by about 38 states. The Marshall method seeks to select the asphalt binder content at a desired density that satisfies minimum stability and range of flow values. The U.S. Army Waterways Experiment Station(WES) continued to refine the Marshall method through the 1950s with various tests on materials, traffic loading and weather variables. **Today the Marshall method, despite its shortcomings, is probably the most widely used mix design method in the world.** It has probably become so widely used because (1) it was adopted and used by the U.S. military all over the world during and after WWII and (2) it is simple, compact and inexpensive.

## II. Hveem mix design and History

The basic concepts of the Hveem mix design method were originally developed by Francis Hveem when he was a Resident Engineer for the California Division of Highways in the late 1920s and 1930s. Currently, the Hveem method is used by several western states.

## III. Superpave mix design and History

One of the principal results from the Strategic Highway Research Program (SHRP) was the Superpave mix design method. The Superpave mix design method was designed to replace the Hveem and Marshall methods. The volumetric analysis common to the Hveem and Marshall methods provides the basis for the Superpave mix design method. The Superpave system ties asphalt binder and aggregate selection into the mix design process and considers traffic and climate as well. The compaction devices from the **Hveem and Marshall procedures have been replaced by a gyratory compactor and the compaction effort in mix design is tied to expected traffic.**

# General Steps of Mix Design / Basic Mix Design Flow Chart

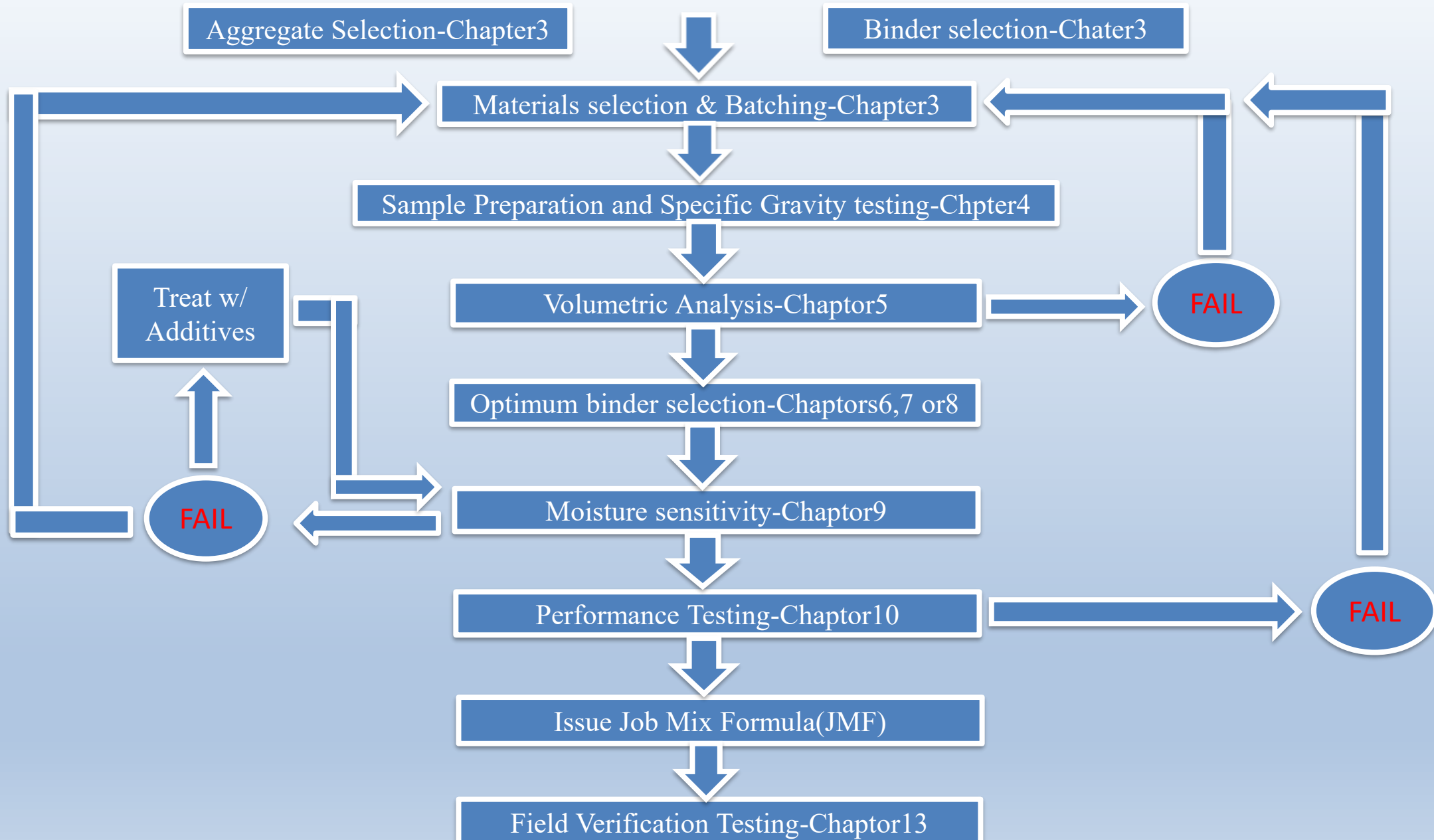

# Understanding Before Mix Design / Phase Diagram

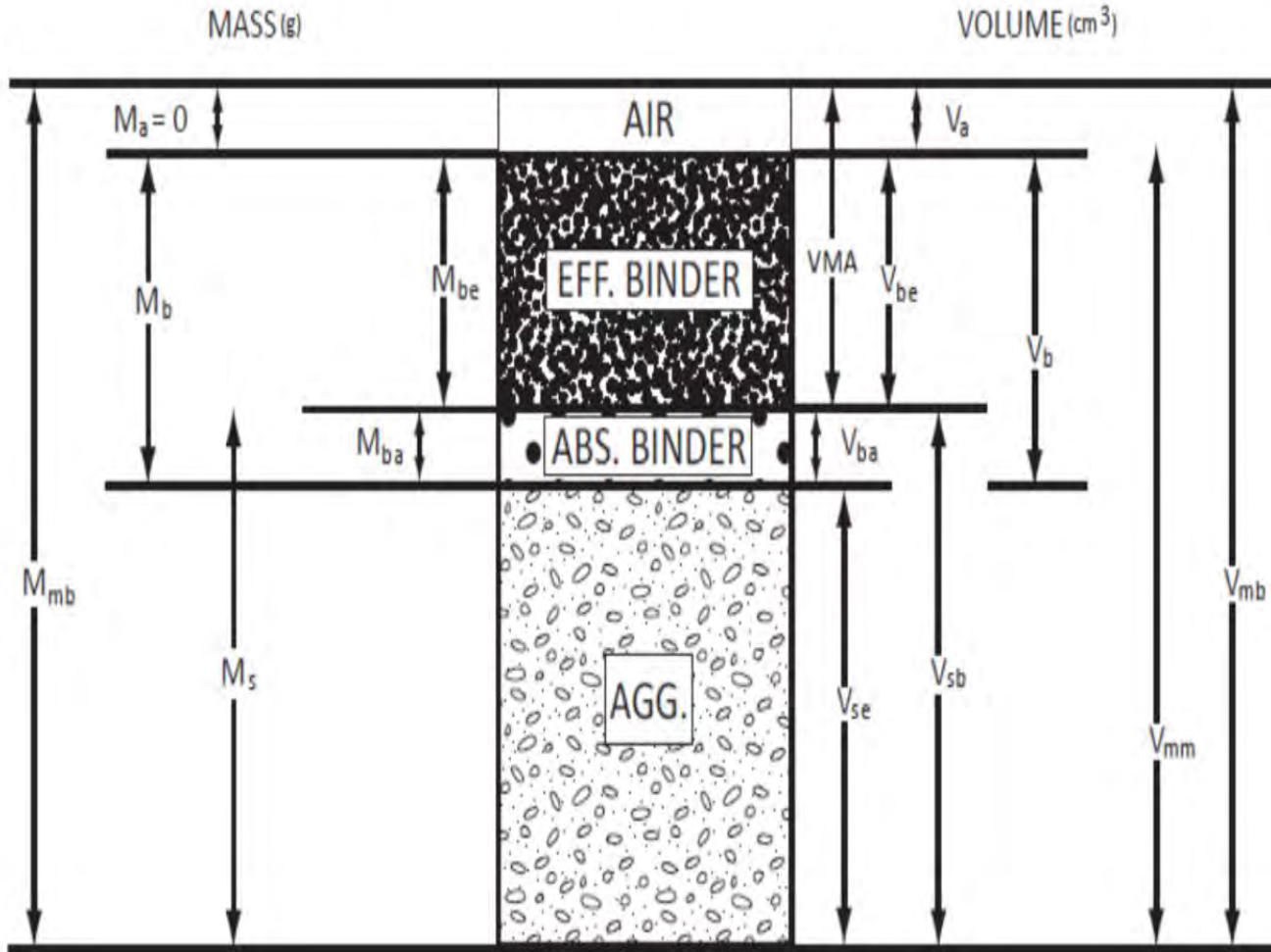

$V_a$  = Volume of Air

$V_b$  = Volume of bitumen

$V_{be}$  = effective Volume of bitumen

**VMA** = Void in Mineral Aggregate =  $(V_a + V_{be}) / V_{mb}$

$V_{ba}$  = Volume of absorb bitumen

$V_{sb}$  = Bulk Volume of Aggregate

$V_{se}$  = Effective Volume of Aggregate

$V_{mb}$  = Bulk Volume of Mix

$V_{mm}$  = Volume of Aggregate and binder

**VFA** = Voids filled with asphalt  $(V_{be} / (V_a + V_{be}))$

**Voids in the mineral aggregate (VMA)** are the void spaces that exist between the aggregate particles in the compacted paving asphalt mixture, including the space filled with the binder.

**Voids filled with asphalt (VFA)** are the void spaces that exist between the aggregate particles in the compacted paving asphalt mixture that are filled with binder. VFA is expressed as a percentage of the VMA that contains binder. (VFA)

### Material Selection and General requirement

#### a. Bitumen

- Penetration Grade
- Viscosity Grade
- Performance Grade ( Superpave)
- Modified Bitumen

#### b. Aggregate ( Fine + Course )

- The coarse aggregates shall consist of crushed rock, crushed gravel or other hard material retained on 2.36 mm sieve.
- They shall be clean, hard, and durable, of cubical shape, free from dust and soft or friable matter, organic or other deleterious substances.
- Use of Anti-Striping agent ( Striping Value test)

# Test Requirements for Coarse Aggregate

Property	Test	Specification	Test Method
Cleanliness	Grain Size Analysis	Max 5% passing 0.075 mm sieve	IS:2386 Part: I
Particle Shape	Combined Flakiness and Elongation Indices	Max 35%	IS:2386 Part: I
Strength	Los Angeles Abrasion Value or Aggregate Impact Value	Max:30 Max:24%	IS:2386 Part: IV
Durability	Soundness either Sodium Sulphate or Magnesium Sulphate	Max:12% Max:18%	IS:2386 Part: V
Polishing	Polish Stone Value	Min: 55%	BS:812-114
Water Absorption	Water Absorption	Max:2%	IS:2386 Part: III
Stripping	Coating and Stripping of Bitumen Aggregate Mix	Minimum Retained Coating: 95%	IS: 6241
Water Sensitivity	Retained Tensile Strength*	Min: 80% (if less need anti stripping agent)	AASHTO 283

Proposed Bitumen: VG30 takes care of Highest 7 days temperature Range of 38-45°C

### Tests as per IS73: 2013

Characteristics	Requirements
1. Penetration at 25°C 100 g, 5 s , 0.1 mm Min	45
2. Absolute viscosity at 60°C, Poises	2400-3600
3. Kinematic viscosity at 135°C cSt Min.	350
4. Flash Point (Cleveland open cup) °C Min.	220
5. Solubility in Trichloroethylene percent Min.	99
6. Softening Point (R&B), °C Min.	47
7. Tests on residue from rolling thin film oven test	
i) Viscosity Ratio at 60°C, Max	4
ii) Ductility at 25°C, cm Min.	40

# Gradation Requirement

Grading	1	2
Nominal Aggregate Size	35.5	26.5
Layer Thickness	75-100	50-75
IS Sieve	Cumulative % by weight of total aggregate passing	Cumulative % by weight of total aggregate passing
45	100	
37.5	95-100	100
26.5	63-93	90-100
19	-	71-95
13.2	55-75	56-80
9.5	-	-
4.75	38-54	38-54
2.36	28-42	28-42
1.18	-	-
0.6	-	-
0.3	7-21	7-21
0.15	-	-
0.075	2-8	2-8
Bitumen Content % by mass of total mix	Minimum 4	Minimum 4.5

## Filler Material Requirement

- Filler should consist of finely divided mineral matter such as rock dust, hydrated lime or cement.
- The filler should be free from organic impurities and have a plasticity Index not greater than 4 ( For Dust)
- Where the mix fail to meet the requirements of the water sensitivity test (80% as min. retained tensile strength, AASHTO T283) , then 2 percent by total weight of aggregate, of hydrated lime should be used and percentage of fine aggregate reduced accordingly.

<b>Grading Requirements for Mineral Filler</b>	
<b>IS sieve (mm)</b>	<b>Cumulative Percent Passing by Weight of Total Aggregate</b>
<b>0.6</b>	<b>100</b>
<b>0.3</b>	<b>98-100</b>
<b>0.075</b>	<b>85.-100</b>

# Marshall Mix Design

- For Dense Graded Bituminous Macadam Wearing Course

Compaction: 75 blows on each face of the specimen

Minimum Stability (KN at 60°C) 12

Marshall flow (mm) 2.5-4

Marshall Quotient (stability/flow) 2.5-5

%Air Voids 3-5

%Voids Filled with Bitumen 65-75

Coating of Aggregate Particles 95% Minimum

Tensile Strength Ratio 80% Minimum

Voids in the Mineral Aggregate (VMA) 10-13 (depending upon use of maximum size of aggregates)

## Step 1: Selection of Materials and Test requirement

- Selection of Materials

  - ✓ 40 down, 26 down, 20 down, 10 down, 4.75 down , dust , bitumen ( Types)

- Test the requirement as above

Specific Gravity test of Aggregate, fine aggregate, bitumen, filler

Sieve Analysis of aggregate , fine aggregate, filler



Specific Gravity test ; 40 down



Specific Gravity test; Coarse aggregate



Specific Gravity test; Fine aggregate

### Aggregate Blending / Job mix

- Use hit and trail method ( Spread Sheet)
- Bailey Method
- Programing based method

Sieve size(mm)	26 down Agg 30 (%)	10 down Agg 25 (%)	Crushed Fine Agg 45(%)	Total	Specification Limit
37.5	30.0	25.0	45.0	100.0	100
26.5	26.4	25.0	45.0	96.40	90-100
19.0	8.5	25.0	45.0	78.53	71-95
13.20	1.3	24.7	45.0	70.96	56-80
4.75	0.6	4.3	36.4	41.31	38-54
2.36	0.0	3.1	30.9	33.94	28-42
0.3	0.0	1.8	11.6	13.39	7-21
0.075	0.0	0.3	3.1	3.36	2-8

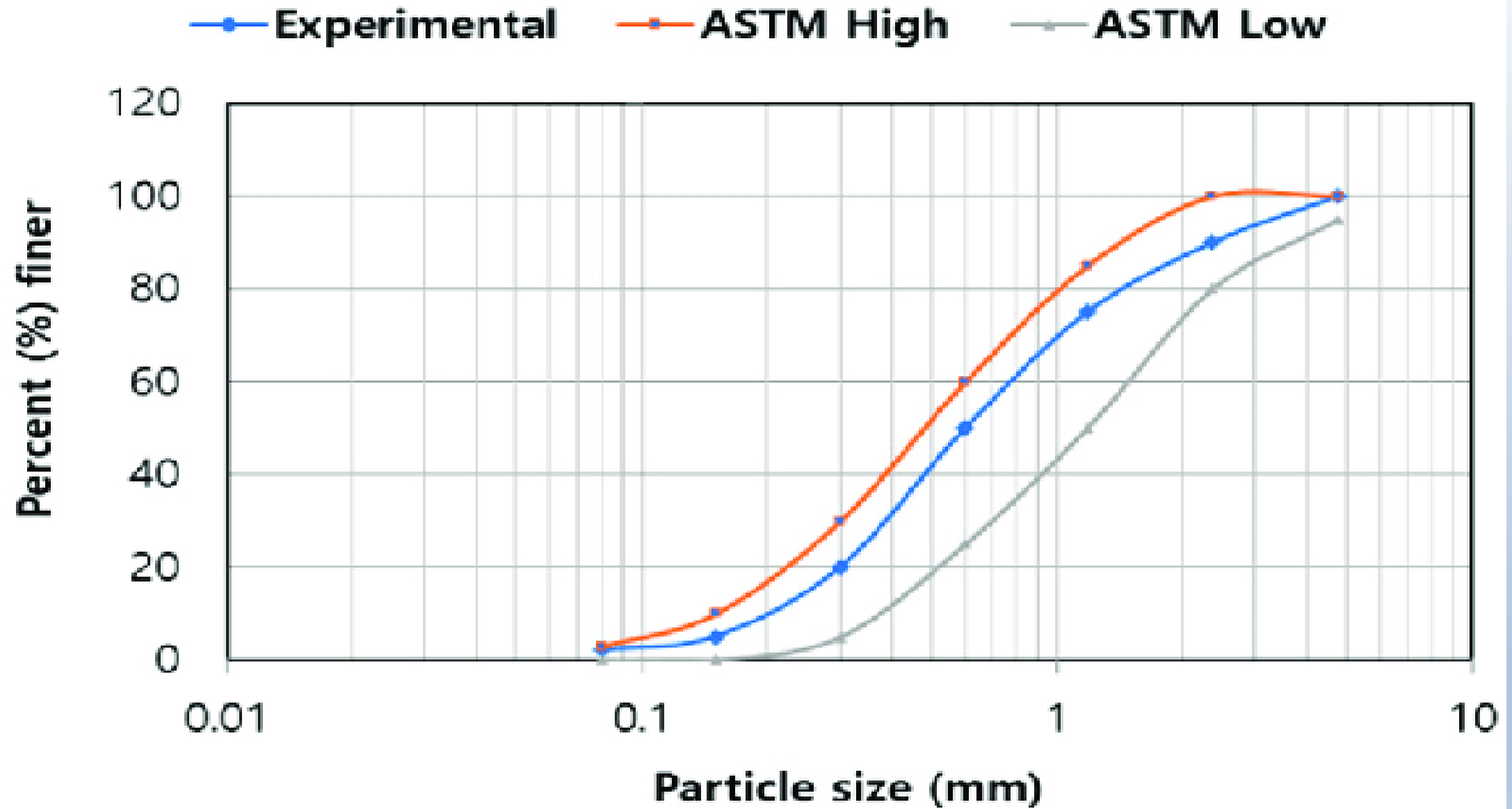

### After Job Mix

- Take around 1200 Gram of Pre heated Mix Aggregate and take pre heated bitumen of different percentage by weight of Mix Aggregate .
- Different percentage range from 4% to 6.5% each increment of .5 % ( binder content)
- The mix by Mixture Equipment or Manually .
- Mixing Temperature should be equal to the temperature at which binder has a viscosity of  $170 \pm 20 \text{ mm}^2/\text{s}$  (  $.17 \pm .02 \text{ Pa.s}$ ) Generally 160 to 165 ° C . Heating should not be greater than 177 ° C .
- Now prepare pre heated mould ( 90 to 143 ° C) and fill up mould with mix and compact immediately in compaction apparatus. The compaction temperature should be equal to the temperature at which binder has viscosity of  $280 \pm 30 \text{ mm}^2/\text{s}$ (  $.28 \pm .03 \text{ Pa.s}$ ) Generally 145 to 150 ° C
- $1 \text{ cSt} = 1 \text{ mm}^2 \cdot \text{s}^{-1}$  ( Kinematic Viscosity)
- Compaction should carried out with 75 blows on each side as per specification. And cool it to the room temperature around 4 to 5 hrs.

# Step 2: Aggregate Blending / Job mix / Blending & Compaction Apparatus



Mixture machine

Marshall test mold



Marshall Test Compactor

Marshall specimen extraction Tools



Figure: Test Specimen of Marshall Method

# Step 3: Volumetric Analysis

Marshall Method Criteria <sup>1</sup>	As per MS-2						As per DOR Specification	
	Light Traffic <sup>2</sup> Surface & Base		Medium Traffic <sup>2</sup> Surface & Base		Heavy Traffic <sup>2</sup> Surface & Base		Viscosity Grade Paving Bitumen	
	Min	Max	Min	Max	Min	Max	Min	Max
Compaction, number of blows each end of specimen	35		50		75		75	
Stability, N	3336	-	5338	-	8006	-	9000	-
Flow <sup>3,4</sup> , 0.25 mm (0.01 in.)	8	18	8	16	8	14	8	16
Percent Air Voids <sup>6</sup>	3	5	3	5	3	5	3	5
Percent Voids in Mineral Aggregate (VMA) <sup>5</sup>	NMAS, mm		Minimum VMA, percent					
			3.0		4.0		5.0	
	13.2		13		14		15	
	19		12		13		14	
	26.5		11		12		13	
37.5		10		11		12		
Percent Voids Filled With Asphalt (VFA)	70	80	65	78	65	75	65	75

## Step 3: Volumetric Analysis

Find out the Percentage Air Voids

$$P_a = 100 \times \frac{V_a}{V_{mb}}$$

Where  $P_a$  = % Air Voids

$V_a$  = Volume of Air Voids

$V_{mb}$  = Bulk Volume of Sample

Another Formula For Lab

$$P_a = 100 - \frac{100 \times G_{mb}}{G_{mm}}$$

Where ,

$G_{mb}$  = Bulk Specific Gravity of the sample

$G_{mm}$  = maximum specific gravity of paving mixture

Determination of  $G_{mb}$  ( Bulk Specific Gravity) in Laboratory

$$G_{mb} = \frac{A}{(B - C)}$$

where:

A = dry mass of the specimen in air

B = saturated surface-dry (SSD) mass of the specimen in air

C = mass of the specimen in water at 25°C

### Determination of $G_{mb}$ ( Bulk Specific Gravity) in Laboratory

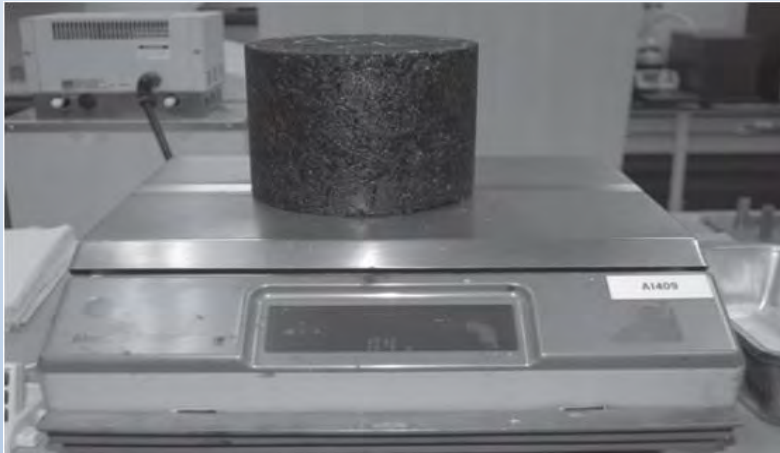

Determination of  $G_{mm}$  (maximum specific gravity of paving mixture) in Laboratory (ASTM D 2041)

$$G_{mm} = \frac{A}{A - (C^* - B)}$$

where:  $G_{mm}$  = maximum specific gravity of the mixture,

$A$  = mass of dry sample in air, g,

$B$  = mass of bowl under water, g,

$C^*$  = mass of bowl and sample under water, g

- The sample should be free from air voids by Specific Gravity meter equipment
- Average of more than two sample

Now Calculate the effective specific gravity ( $G_{se}$ )

$$G_{se} = \frac{P_s}{\left(\frac{100}{G_{mm}}\right) - \left(\frac{P_b}{G_b}\right)}$$

Where,

$P_s$  = % of Aggregate by total mix Weight

$P_b$  = % of Binder Content by total mix Weight

$G_{mm}$  = Maximum Specific Gravity of Paving mixture

$G_b$  = Specific Gravity of Binder

Calculation of the Maximum specific gravity ( $G_{mm}$ ) of paving mixture of different binder Contents

$$G_{mm} = \frac{100}{\left(\frac{P_s}{G_{se}}\right) + \left(\frac{P_b}{G_b}\right)}$$

Where,

$P_s$  = % of Aggregate by total mix Weight

$P_b$  = % of Binder Content by total mix Weight

$G_{se}$  = Effective Specific Gravity of Paving mixture

$G_b$  = Specific Gravity of Binder

- As binder content increases  $G_{mm}$  always decreases.

Calculation of the % Air Voids of sample ( $P_a$ )

$$P_a = \frac{G_{mm} - G_{mb}}{G_{mm}} \times 100$$

Where,

$G_{mm}$  = Maximum Specific Gravity of Sample

$G_{mb}$  = Bulk Specific Gravity of Binder

- As binder content increases  $G_{mm}$  always decreases.

Calculation of the Voids in Mineral Aggregate ( VMA) of sample

$$\text{VMA} = \frac{G_{sb} - P_s * G_{mb}}{G_{sb}} \times 100$$

Where,

$G_{sb}$  = combine Specific Gravity of Aggregate

$G_{mb}$  = Bulk Specific Gravity of Binder

$P_s$  = % of aggregate by Total mix weight

Calculation of the Voids fill with Asphalt ( VFA) of sample

$$VFA = \frac{VMA - P_a}{VMA} \times 100$$

Where,

$P_a$  = Percentage Air Voids %

$G_{mb}$  = Bulk Specific Gravity of Binder

## Step 4: Stability and Flow Value

- Marshall testing machine conforming to ASTM D6927
- Specimen diameter is 101.6 mm , height is 63.5 mm
- For modified diameter is 152.4 mm, height is 95.2 mm
- After determination of bulk specific gravity,
  - Measure the height of sample ( required for correction)
  - Immerse specimen in water bath  $60^{\circ}\text{C} \pm 1^{\circ}\text{C}$  for 30 to 40 minutes
  - Use automatic recording device
  - Testing head maintained temperature at  $21.1$  to  $37.8^{\circ}\text{C}$
  - Zero reading and Apply load at the rate of 51 mm deflection per minutes
  - Record the maximum stability value and flow value
  - Complete all action within 30 seconds
  - Stability correction as per height different then 63.5 mm

# Step 4: Stability and Flow Value/ Marshall Stability Test Apparatus

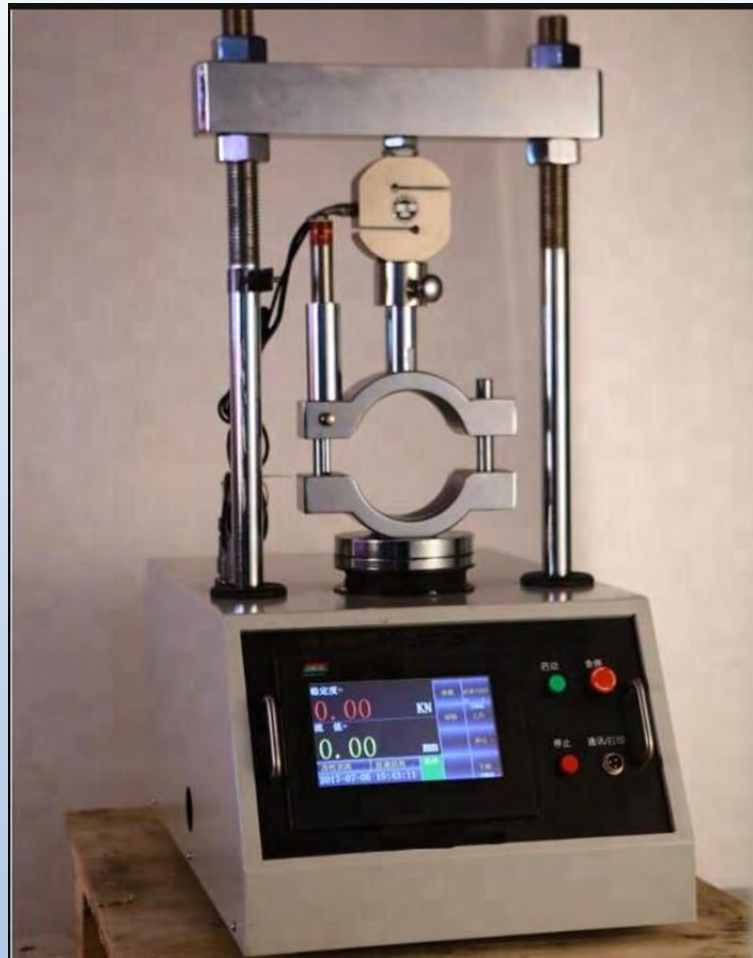

Digital Marshall Stability Test Tester



Marshall Stability Test Tester

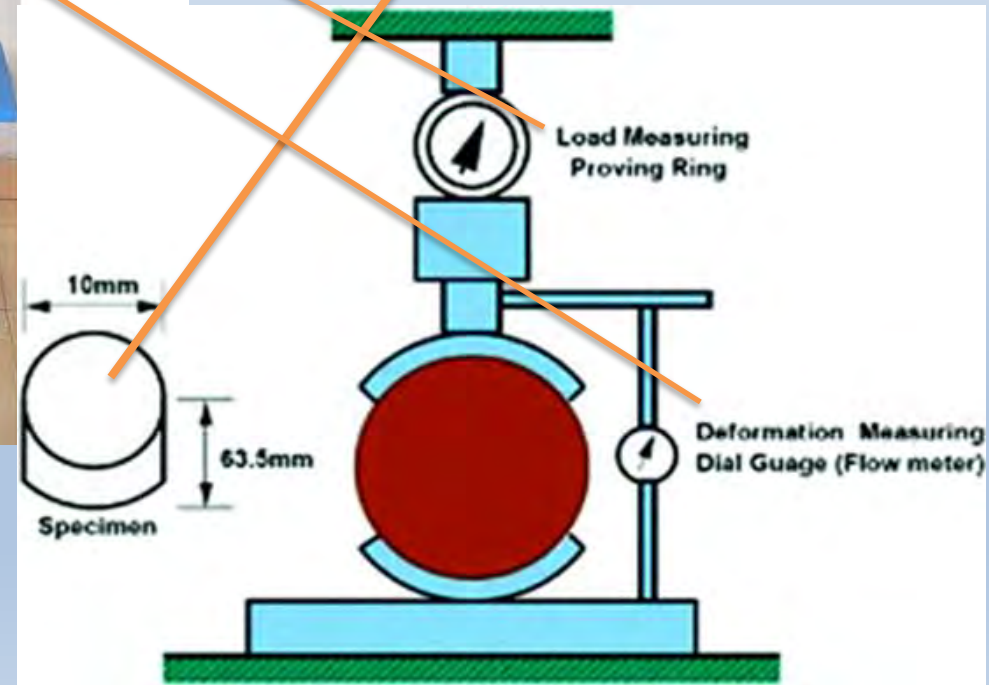

## Step 4: Stability and Flow Value

- Use Stability Correction Chart as per thickness of sample ( page No.86 of MS 2)
- Use correction in flow value in case of automatic reading devices (For analog system correction is not required depending up on experience )

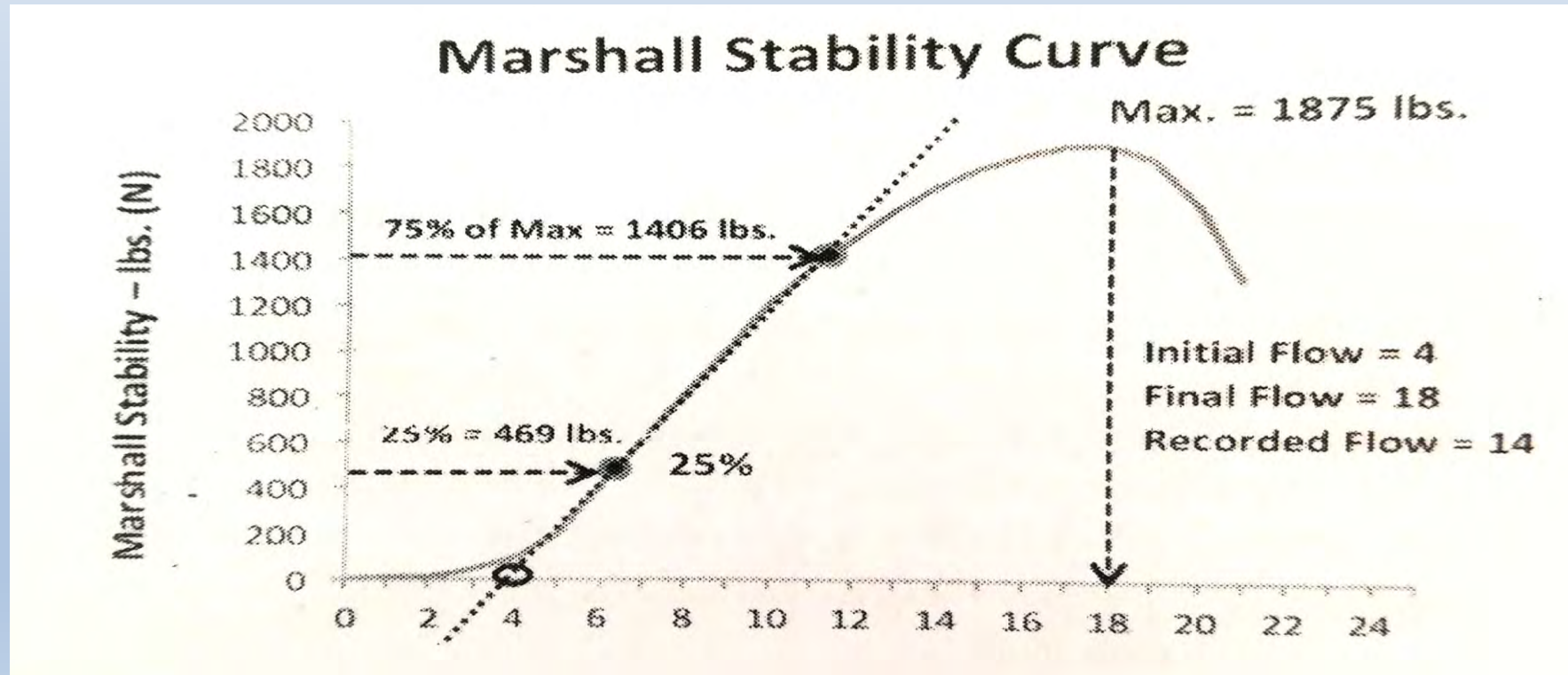

- Bulk Density( $G_{mb}$ ) increases with the increase in Binder Content ( $P_b$ ) Voids filled with binder slightly reduces the volume and increases the mass
- For filled void the volume increases thus slightly reduce in Bulk density ( $G_{mb}$ )
- As the binder content increases Theoretical Maximum Gravity( $G_{mm}$ ) always decreases because of higher specific Gravity of aggregate than binder
- Air Voids ( $P_a$ ) always decreases with the increase in binder content
- %Void in mineral aggregate (VMA) initially decreases and then increases with the increase in binder contents
- %Void filled with asphalt (VFA) always increases with the increase in binder content
- Stability Value increases up to maximum and then decreases with the increase in binder content
- Flow Value continuously increases with increase in binder content

# Step 5: Analysis on different parameters with respect to binder Contents

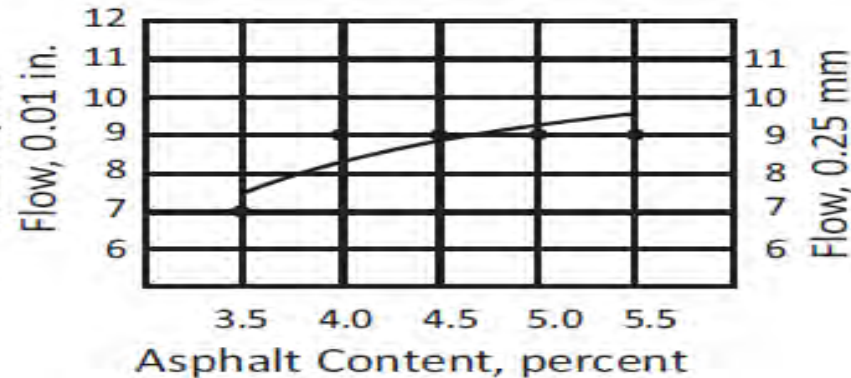
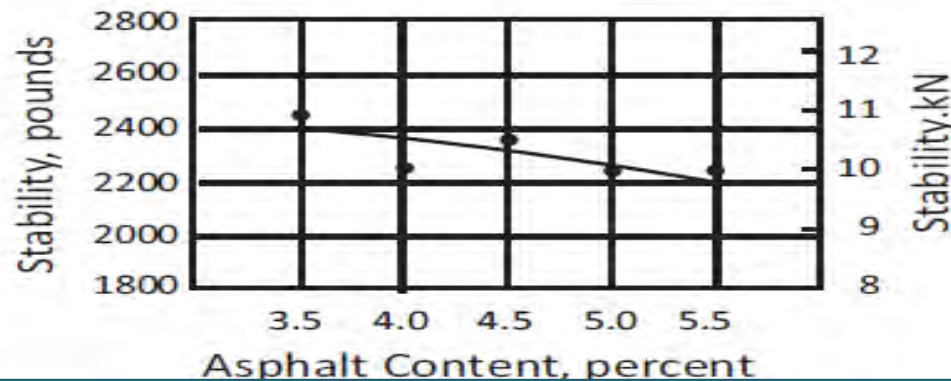
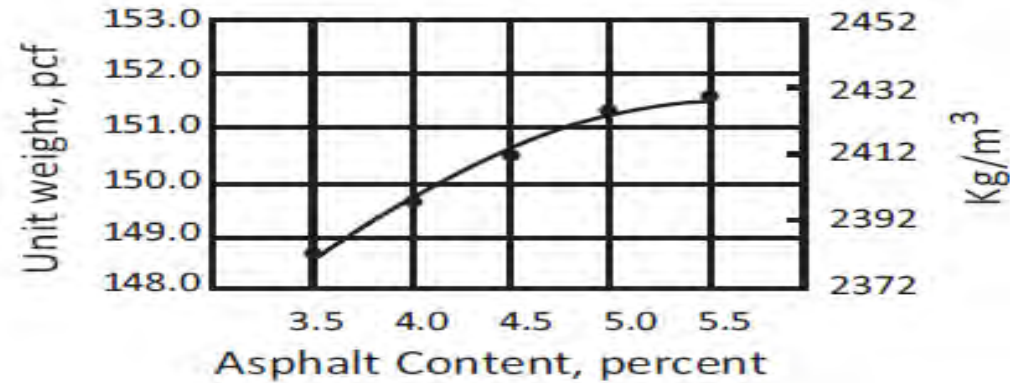
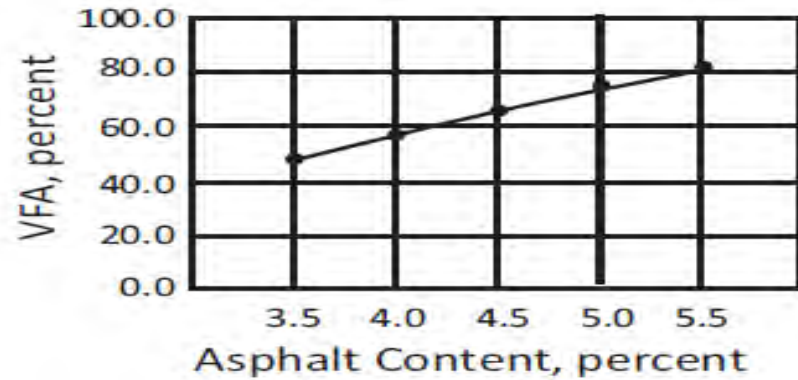
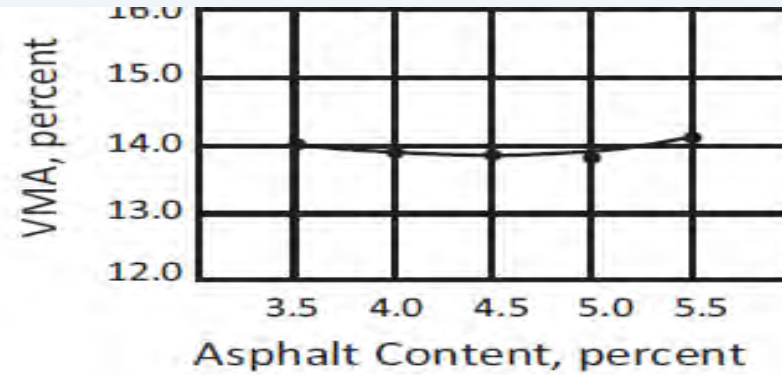
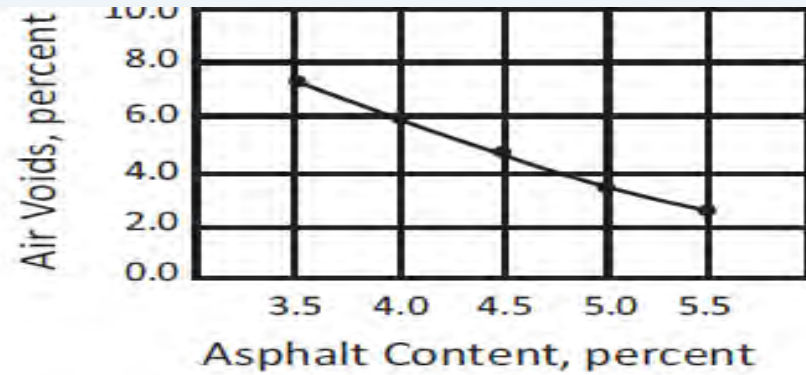

- From the graph between binder content and air void find the optimum binder content for 4% air voids
- After finding the optimum binder content then find other parameters such as;
  - ✓ Density, Stability, VFA, VMA, Flow as per specification limit
- If the requirement is not met repeat the test
- Repetition and experience leads to accurate design

- Generally aggregate size is more than 25mm up to 38 mm
- Less deviation in data
- Hammer weight is 10.2 kg (4.5 Kg for non modified )
- Specimen diameter is 152.4 mm (101.6 mm for non modified)
- Height is 92.5 mm (63.5 mm)
- No of blows is 75 or 112 each side (i.e. 1.5 times than non modified)
- Minimum stability is 2.25 times than non modified, Flow value is 1.5 times than non modified
- Stability correction factor is different as per thickness

# Design Criteria as per MS 2

Marshall Method Criteria <sup>1</sup>	Light Traffic <sup>3</sup> Surface & Base		Medium Traffic <sup>3</sup> Surface & Base		Heavy Traffic <sup>3</sup> Surface & Base	
	Min	Max	Min	Max	Min	Max
Compaction, number of blows each end of specimen	35		50		75	
Stability <sup>2</sup> , N (lb.)	3336 (750)	-	5338 (1200)	-	8006 (1800)	-
Flow <sup>2,4,5</sup> , 0.25 mm (0.01 in.)	8	18	8	16	8	14
Percent Air Voids <sup>7</sup>	3	5	3	5	3	5
Percent Voids in Mineral Aggregate (VMA) <sup>6</sup>	See Table 7.3					
Percent Voids Filled With Asphalt (VFA)	70	80	65	78	65	75

**NOTES:**

- All criteria, not just stability value alone, must be considered in designing an asphalt paving mix.
- Hot mix asphalt bases that do not meet these criteria when tested at 60°C (140°F) are satisfactory if they meet the criteria when tested at 38°C (100°F) and are placed 100 mm (4 inches) or more below the surface. This recommendation applies only to regions having a range of climatic conditions similar to those prevailing throughout most of the United States. A different lower test temperature may be considered in regions having more extreme climatic conditions.
- Traffic classifications  
 Light Traffic conditions resulting in a 20-year Design ESAL < 10<sup>4</sup>  
 Medium Traffic conditions resulting in a 20-year Design ESAL between 10<sup>4</sup> and 10<sup>6</sup>  
 Heavy Traffic conditions resulting in a 20-year Design ESAL > 10<sup>6</sup>
- The flow value refers to the point where the load begins to decrease. When an automatic recording device is used, the flow should be corrected as shown in section 7.3.3.3.
- The flow criteria were established for neat asphalts. The flow criteria are often exceeded when polymer-modified or rubber-modified binders are used. Therefore, the upper limit of the flow criteria should be waived when polymer-modified or rubber-modified binders are used.
- Percent voids in the mineral aggregate are to be calculated on the basis of the ASTM bulk specific gravity for the aggregate, as discussed in chapter 5.
- Percent air voids should be targeted at 4 percent. This may be slightly adjusted if needed to meet the other Marshall criteria.

From the above tests determine the following:

- Quantities of Various Size of Aggregates
- Quantities of Fillers
- Quantity of Binder

The process after that is given below:

- Add together the quantities of coarse and fine material : (100%)
- Percentage of binder added to the mix in relation to the coarse and fine binder.
- Add together the various percentages of material (this is more than 100%) = (a)
- Determine the actual percentage of each type of aggregates and binder by multiplying with 100 and dividing by (a)
  - ✓ The result from this process is the Job Mix Formula (JMF)
- Tolerances of job mix materials as per specification

1. Load calibration of the Mixing Plant
2. Extraction of bitumen from the sample and various sizes of aggregates
3. Tests for Marshall Criteria
4. Residual Stability after soaking the test sample in water bath at 60°C for 24 hours and test for stability.
  - ✓ The residual stability should not be less than 75%
5. Core cutting and tested for thickness and required density (min 98%)
6. Frequency of testing as per specification

Since asphalt pavement is the main construction subject for periodic maintenance work, it is especially important for the supervisor to confirm the contents of the mix design document of the asphalt mixture. Check point of the mix design document are shown in below.

### Check point of mix design document

No	Check items	Contents of the test
1	Determination of the material	a. Confirmation of materials used (sand, aggregate, asphalt)
		b. Confirmation of test results of materials used (Grading test, Specific gravity, Water absorption, Los angeles weight loss, Elongation & flatness)
2	Check the quality regulation of the asphalt mixture	a. Confirmation of mix proportion & combined gradation
		b. Confirmation of air void and void filled with asphalt
		c. Determination of the optimum asphalt content and mix gradation
		d. Make a diagram by mashall stability test result.
3	Durability confirmation by asphalt mixture	a. Mashall stability test ( standard and soak in water)
4	Determination of the optimum asphalt content by laboratory test	a. Final confirmation of combined gradation
		b. Final confirmation of optimum asphalt content



Removal of Asphalt Concrete for reconstruction at CH 93+900 to CH 93+500 (Sec. III) at Mulkot Bend

- Field Density  $\geq 98\%$  of Mat Density (Individual density should not be  $< 96\%$ )
- Joint Density  $\geq 94\%$  (no individual density should be  $< 90\%$ )
- Thickness; average thickness should be as design thickness
- Smoothness of Grade; Grade should be smooth

THANK YOU  
FOR YOUR ATTENTION!

Durga Prasad Osti



Presentation and Submission of Results  
on  
Asphalt Concrete Mix Design and  
Quality Control in Pavement  
Construction

Day 1: 14<sup>th</sup> February



Inauguration of Training Session by former DDG



# Aggregate Tests

Gradation



LAA



AIV



Flakiness Index



Elongation Index



Sp Gravity and Water Absorption



# Aggregate Tests(Gradation)

20 mm Down,  
16 mm Down,  
10 mm Down  
and Dust were  
used(For DBM,  
50-75 mm layer  
thickness)(claus  
e 1308(2))

Different  
aggregate samples  
were sieved  
separately with  
the sieve sizes as  
mentioned in the  
table 13.28 of  
Standard  
specifications for  
road and bridges

Grading of  
dust(filler) were  
done in  
accordance with  
table 13.27 of  
standard  
specifications of  
road and bridges.

The gradation  
aggregates  
were within the  
range as per  
standard  
specifications

Other  
aggregate  
tests(LAA,AIV,  
FI,El,Sp.Gravity  
and Water  
Absorption)  
were carried  
out.



# Aggregate Tests

Nepal Government  
Ministry of Physical Infrastructure and Transport  
Department of Roads  
Quality Research and Development Centre  
**LABORATORY WORKSHEET FOR SIEVE ANALYSIS**

Operator: \_\_\_\_\_ Project: \_\_\_\_\_  
Date: \_\_\_\_\_ Sample No.: \_\_\_\_\_  
Sample Type: 10 mm Agg Before wash Weight in gm

Sieve Size	Course Fraction		Fine Fraction				Cumulative % Passing TOTAL	Specification Limits
	U.S. Standard	M.M.	Wt. Retained individual GRAMS	Wt. Passing Cumulative GRAMS	Wt. Retained individual GRAMS	Wt. Passing Cumulative GRAMS		
Orig.								
3"	75							
2 1/2"	63							
2"	50							
1-1/2"	40							
1"	25.0							
3/4"	19.0		5844					
1/2"	12.5	0						
3/8"	9.5	380	4664			92.47		
1/4"	6.3							
No. 4	4.75	3316	1248			26.72		
8	2.36	764	584			11.58		
10	2.00							
16	1.18							
20	0.850							
30	0.600	254	870			6.54		
40	0.425							
50	0.300					4.5 (Assumed)		
80	0.180							
100	0.150							
200	0.075	208	172			2.41		
Pan	✓	122						
Wash								
Total		5844						

Tested by: \_\_\_\_\_ Checked by: \_\_\_\_\_

Nepal Government  
Ministry of Physical Infrastructure and Transport  
Department of Roads  
Quality Research and Development Centre  
**LABORATORY WORKSHEET FOR SIEVE ANALYSIS**

Operator: \_\_\_\_\_ Project: \_\_\_\_\_  
Date: \_\_\_\_\_ Sample No.: \_\_\_\_\_  
Sample Type: 16 mm Agg Before wash Weight in gm

Sieve Size	Course Fraction		Fine Fraction				Cumulative % Passing TOTAL	Specification Limits
	U.S. Standard	M.M.	Wt. Retained individual GRAMS	Wt. Passing Cumulative GRAMS	Wt. Retained individual GRAMS	Wt. Passing Cumulative GRAMS		
Orig.								
3"	75							
2 1/2"	63							
2"	50							
1-1/2"	40							
1"	25.0	0	5156			100		
3/4"	19.0	18416	84	5072		98.37		
1/2"	12.5	1226	3846			74.39		
3/8"	9.5	3500	346			6.21		
1/4"	6.3							
No. 4	4.75	332	14			0.27		
8	2.36							
10	2.00							
16	1.18							
20	0.850							
30	0.600							
40	0.425							
50	0.300					0.27		
80	0.180							
100	0.150							
200	0.075							
Pan	✓	14				0.27		
Wash								
Total		5156						

Tested by: \_\_\_\_\_ Checked by: \_\_\_\_\_

Nepal Government  
Ministry of Physical Infrastructure and Transport  
Department of Roads  
Quality Research and Development Centre  
**LABORATORY WORKSHEET FOR SIEVE ANALYSIS**

Operator: \_\_\_\_\_ Project: \_\_\_\_\_  
Date: \_\_\_\_\_ Sample No.: \_\_\_\_\_  
Sample Type: 20 mm Agg Before wash Weight in gm

Sieve Size	Course Fraction		Fine Fraction				Cumulative % Passing TOTAL	Specification Limits
	U.S. Standard	M.M.	Wt. Retained individual GRAMS	Wt. Passing Cumulative GRAMS	Wt. Retained individual GRAMS	Wt. Passing Cumulative GRAMS		
Orig.								
3"	75							
2 1/2"	63							
2"	50							
1-1/2"	40							
1"	25.0	48865	0					
3/4"	19.0	28020	392					
1/2"	12.5	18076	5960					
3/8"	9.5	129302	3080					
1/4"	6.3	✓9.5	816					
No. 4	4.75	21						
8	2.36							
10	2.00							
16	1.18							
20	0.850							
30	0.600							
40	0.425							
50	0.300							
80	0.180							
100	0.150							
200	0.075							
Pan	✓	9						
Wash								
Total		92326						

Tested by: \_\_\_\_\_ Checked by: \_\_\_\_\_

Nepal Government  
Ministry of Physical Infrastructure and Transport  
Department of Roads  
Quality Research and Development Centre  
**LABORATORY WORKSHEET FOR SIEVE ANALYSIS**

Operator: \_\_\_\_\_ Project: \_\_\_\_\_  
Date: \_\_\_\_\_ Sample No.: \_\_\_\_\_  
Sample Type: Dust Before wash Weight in gm 73.10

Sieve Size	Course Fraction		Fine Fraction				Cumulative % Passing TOTAL	Specification Limits
	U.S. Standard	M.M.	Wt. Retained individual GRAMS	Wt. Passing Cumulative GRAMS	Wt. Retained individual GRAMS	Wt. Passing Cumulative GRAMS		
Orig.								
3"	75							
2 1/2"	63							
2"	50							
1-1/2"	40							
1"	25.0							
3/4"	19.0							
1/2"	12.5					57.21		
3/8"	9.5					0		
1/4"	6.3							
No. 4	4.75					48.6	52.5	91.5
8	2.36					71.3	45.27	79.04
10	2.00							
16	1.18					103.0	34.2	61.64
20	0.850							
30	0.600					62	287.2	50.2
40	0.425							
50	0.300					73.2	208	36.4
80	0.180							
100	0.150					94.8	173.2	19.79
200	0.075					35.1	76.1	13.65
Pan	✓							
Wash						78.1		
Total						172.0		

Tested by: \_\_\_\_\_ Checked by: \_\_\_\_\_

# Aggregate Tests

Nepal Government  
Ministry of Physical Infrastructure and Transport  
Department of Roads  
Quality Research and Development Centre

Sheet Index No.: 105  
95

## LOS ANGELES ABRASION TEST WORK SHEET

Project/Office: \_\_\_\_\_ Grading: B Date of testing: \_\_\_\_\_  
Aggregate type: \_\_\_\_\_ No. of spheres used: 11 Field Sample No.: \_\_\_\_\_  
Source: \_\_\_\_\_  
Sampled: \_\_\_\_\_

Description	Test Number			Remarks
	1	2	3	
Wt. of specimen $W_1$ (gm)	500.40			
Wt. of specimen after abrasion test, on 1.70mm IS sieve, $W_2$ (gm)	379.6			
Loss in weight = $\frac{W_1 - W_2}{W_1} \times 100\%$	24.88			
Percentage of wear				

Checked by: \_\_\_\_\_

LAA

Department of Roads  
Central Road Laboratory

## AGGREGATE IMPACT VALUE BS 812

Operator: \_\_\_\_\_ Project: \_\_\_\_\_  
Date: \_\_\_\_\_ Sample No.: \_\_\_\_\_

**SAMPLE PREPARATION**  
Sample Passing  $\frac{1}{2}$  Sieve/Retained on  $\frac{3}{8}$  Sieve

	Wt. Measured	Compacted Sample	
A1	1354.0	gms	
A2	919.0	gms	
A	340	gms	

**PROCEDURE**

Determination No.	1	2	
Passing 2.83mm (No. 7) Sieve	56		gms
Retained on 2.83mm (No. 7) Sieve			gms
Total = B+C			gms
Note: If D more than 1 gm Diff to A than repeat Test.			
Aggregate Impact Value = (B/A) x 100%	16.4		%
Average Aggregate Impact Value	16.4		%

Reported Aggregate Impact Value = 16.4 %

AIV

FI

## WORKSHEET FOR FLAKINESS INDEX

Project: \_\_\_\_\_ Operator: \_\_\_\_\_  
Date: \_\_\_\_\_ Sample No.: 2000 Agg.

Information from gradation Analysis on same sample. Being tested for flakiness

Sieve Size mm	Flakiness plate Slot size Indefication		Total weight Tested
	A	B	
50			D+E
40			
25 to 19	332	60	392
19 to 16	1352	192	1544
16 to 12.5	656	136	792
12.5 to 9.5	736	96	832
9.5 to 6.3			
Total		484	3560

Flakiness Index (%) =  $\frac{\text{Total of column E}}{\text{Total of column F}} \times 100\%$

Flakiness Index (%) = 13.6

EI

# Aggregate Tests (Specific Gravity and Water Absorption)

Department of Roads  
Quality Research and Development Centre  
WORKSHEET FOR SPECIFIC GRAVITY & ABSORPTION OF COARSE AGGREGATE C 127

Operator: \_\_\_\_\_ Project/Office: \_\_\_\_\_  
Date: \_\_\_\_\_ Sample No.: 200000000

Total Sample YES/NO  
Fraction of Sample YES/NO: Fraction size \_\_\_\_\_ mm to \_\_\_\_\_ mm

Determination Number	1	2	3	Average	
B1 WT. PAN + SAT. SUR. DRY SAMPLE	2091.2				gm
B2 WT. PAN	188.1				gm
B WT. SAMPLE SAT. SUR. DRY = B1-B2	1683.6				gm
C1 WT. BASKET + SAMPLE IN WATER	1586.0				gm
WT. BASKET IN WATER	547.3				gm
WT. SAMPLE IN WATER C1-C2	1038.7				gm
WT. PANOVEN DRY SAMPLE	2080.5				gm
WT. PAN	418.1				gm
WT. PANOVEN DRY SAMPLE A1-A2	1622.4				gm
Bulk G (OVEN DRY) = $\frac{A}{B-C}$	$\frac{1622.4}{644.9}$	2.593			
Bulk G (SSD) = $\frac{B}{B-C}$	$\frac{1683.6}{644.9}$	2.611			
Apparent G = $\frac{A}{A-C}$	$\frac{1678.4}{633.2}$	2.639			
Absorption = $\left[ \frac{B-A}{A} \right] \times 100\%$	$\left[ \frac{1622.4 - 1683.6}{1683.6} \right] \times 100\%$	3.61%			%

REJECT TEST RESULTS WHERE G DIFFERS BY MORE THAN 0.03

20 mm

Nepal Government  
Ministry of Physical Infrastructure and Transport  
Department of Roads  
Quality Research and Development Centre  
WORKSHEET FOR SPECIFIC GRAVITY & ABSORPTION OF COARSE AGGREGATE C 127

Operator: \_\_\_\_\_ Project/Office: \_\_\_\_\_  
Date: \_\_\_\_\_ Sample No.: 16

Total Sample YES/NO  
Fraction of Sample YES/NO: Fraction size \_\_\_\_\_ mm to \_\_\_\_\_ mm

Determination Number	1	2	3	Average	
B1 WT. PAN + SAT. SUR. DRY SAMPLE	1754.2				gm
B2 WT. PAN	414.5				gm
B WT. SAMPLE SAT. SUR. DRY = B1-B2	1339.7				gm
WT. BASKET + SAMPLE IN WATER	1356.4				gm
WT. BASKET IN WATER	572.3				gm
WT. SAMPLE IN WATER C1-C2	784.1				gm
WT. PANOVEN DRY SAMPLE	1744.9				gm
WT. PAN	414.5				gm
WT. PANOVEN DRY SAMPLE A1-A2	1309.5				gm
Bulk G (OVEN DRY) = $\frac{A}{B-C}$	$\frac{1309.5}{895.0}$	1.453			
Bulk G (SSD) = $\frac{B}{B-C}$	$\frac{1339.7}{895.0}$	1.498			
Apparent G = $\frac{A}{A-C}$	$\frac{1339.7}{525.6}$	2.550			
Absorption = $\left[ \frac{B-A}{A} \right] \times 100\%$	$\left[ \frac{1309.5 - 1339.7}{1339.7} \right] \times 100\%$	2.25%			%

REJECT TEST RESULTS WHERE G DIFFERS BY MORE THAN 0.03

16 mm

Department of Roads  
Quality Research and Development Centre  
WORKSHEET FOR SPECIFIC GRAVITY & ABSORPTION OF COARSE AGGREGATE C 127

Operator: \_\_\_\_\_ Project/Office: \_\_\_\_\_  
Date: \_\_\_\_\_ Sample No.: 10

Total Sample YES/NO  
Fraction of Sample YES/NO: Fraction size \_\_\_\_\_ mm to \_\_\_\_\_ mm

Determination Number	1	2	3	Average	
B1 WT. PAN + SAT. SUR. DRY SAMPLE	2094.2				gm
B2 WT. PAN	439.5				gm
B WT. SAMPLE SAT. SUR. DRY = B1-B2	1564.7				gm
WT. BASKET + SAMPLE IN WATER	1516.9				gm
WT. BASKET IN WATER	547.3				gm
WT. SAMPLE IN WATER C1-C2	969.6				gm
WT. PANOVEN DRY SAMPLE	1984.0				gm
WT. PAN	439.5				gm
WT. PANOVEN DRY SAMPLE A1-A2	1554.5				gm
Bulk G (OVEN DRY) = $\frac{A}{B-C}$	$\frac{1554.5}{580.5}$	2.678			
Bulk G (SSD) = $\frac{B}{B-C}$	$\frac{1564.7}{580.5}$	2.695			
Apparent G = $\frac{A}{A-C}$	$\frac{1564.7}{555.6}$	2.816			
Absorption = $\left[ \frac{B-A}{A} \right] \times 100\%$	$\left[ \frac{1554.5 - 1564.7}{1564.7} \right] \times 100\%$	0.65%			%

10 mm

Operator: \_\_\_\_\_ Project/Office: \_\_\_\_\_  
Date: \_\_\_\_\_ Sample No.: 25

DETERMINATION No.	1	2	3	
A WT. PYC + WATER (FULL)	745.1			gm
B WT. PYC EMPTY & DRY	221.0			gm
T1 TEMP OF WATER	25.6			C
C WT. PYC + OVEN DRY SAMPLE	778.8			gm
D WT OF OVEN DRY SAMPLE = C - B	557.8			gm
E WT PYC + SAMPLE + WATER (FULL)	1093.5			gm
T2 TEMP OF WATER	25.5			C
REL DENSITY OF WATER AT TEMP T2				
SPECIFIC GRAVITY = $\frac{D}{D+A-E}$	2.684			

REJECT TEST RESULTS WHERE GS DIFFERS BY MORE THAN 0.03

T1 GW	T2 GW
0.998244	0.997070
0.998347	0.9968156

Dust

# Aggregate Tests

Tests	Results		Required Values
Sieve Analysis	Gradation limit within specifications		Table 13.28, Grading 2 of Standard Specifications
LAA	24.08%		Max 35%
AIV	16.4%		Max 27%
Flakiness Index	13.59 %	26.29 %	Max 35% Combined
Elongation Index	13.1%		
Specific Gravity	2.639		
Water absorption	0.67 %(For 20 mm)		<2%
	0.78% (For 16 mm)		
	0.65%(For 10 mm)		

# Aggregate Tests(Job Mix)

Job mix method (option 1)						
sieve size(mm)	20 down%	16 down%	10 down%	Dust %		
37.5	100	100	100	100		
26.5	100	100	100	100		
19.0	96.15	98.37	100	100		
13.2	8.3	74.59	100	100		
4.750	0.08	0.27	26.72	91.5		
2.360	0	0.27	11.58	79.04		
0.300	0	0.27	4.5	36.4		
0.075	0	0	2.41	13.65		
						<b>Grading 2(50-75 MM)</b>
sieve size(mm)	24 (%)	16 (%)	24 (%)	36 (%)	100 Total	Specification Limit
37.5	24.00	16	24	36	100.0	100
26.5	24.00	16	24	36	100.0	90-100
19.0	23.08	15.74	24	36	98.8	71-95
13.2	1.99	11.93	24	36	73.9	56-80
4.750	0.02	0.04	6.41	32.94	39.4	38-54
2.360	0.00	0.04	2.78	28.45	31.3	28-42
0.300	0.00	0.04	1.08	13.10	14.2	7-21
0.075	0.00	0.00	0.58	4.91	5.5	2-8

By Trial and Error

# Bitumen Tests(VG-30)

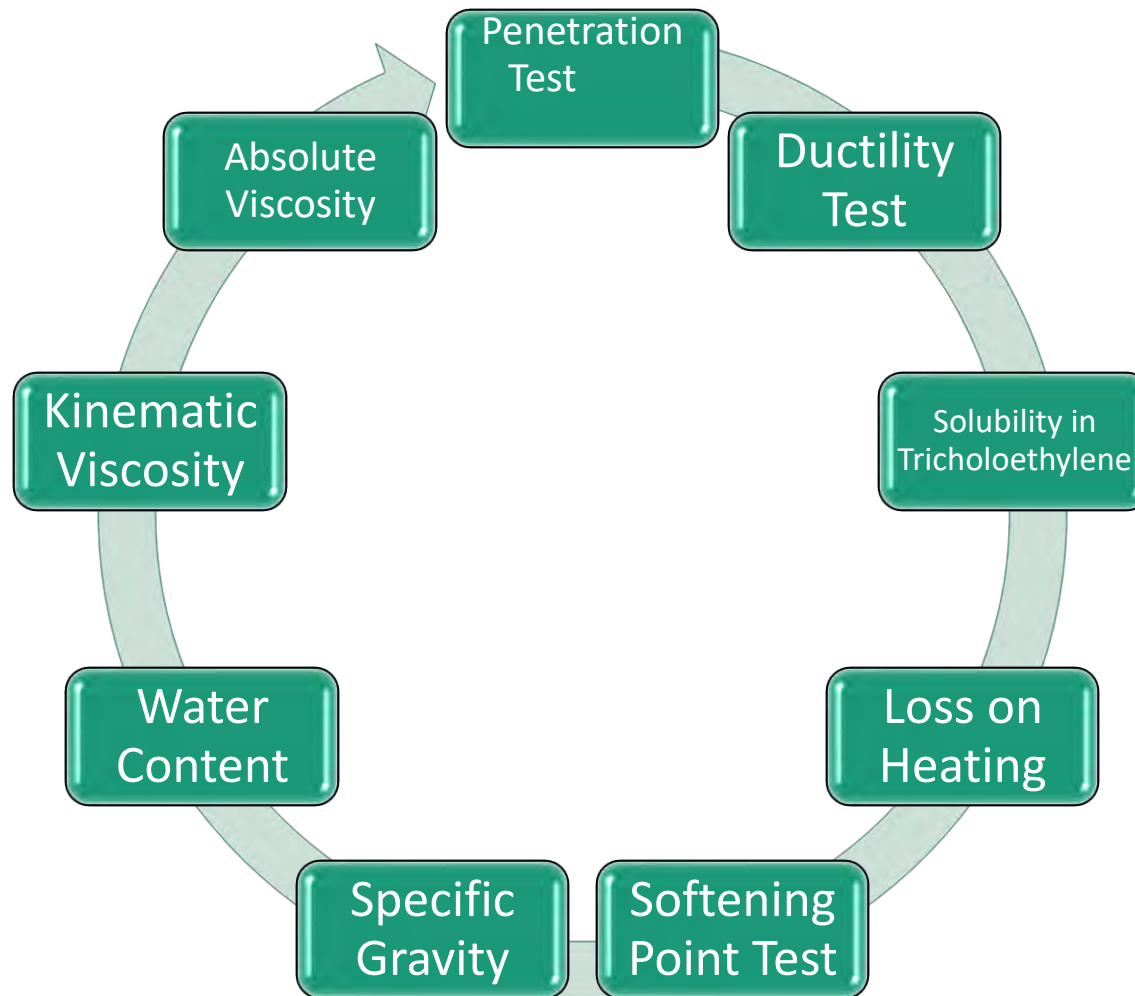

# Bitumen Tests

Quality Research and Development Centre											
Test on Bitumen											
Sample Description : VG-30											
Penetration, 1/10mm (at 25°C)						Flash/Fire	Ductility Cm (25°C)	Solubility In Trichloroethylene, %		Loss on heating (at 163°C, 5hrs) %	
1	2	3	1	2	3						
57	58	57	55	56	57	280	100	a. Sample (gm)	2.000	a. can (gm)	54.84
								b. Dry Filter (gm)	0.614	b. samp+can,bef.(gm)	103.36
								c. Dry Filter+Res.(gm)	0.629	c. samp+can,aft.(gm)	103.23
								d. Residue (gm) (c-b)	0.015	d. samp bef(b-a) (gm)	48.522
Average =		57	Average =		56	320		solubility (100-d/a*100) =	99.25	e. loss wt(b-c) (gm)	0.13
		57			56	280	100			loss %(e*100/d) =	0.270
						320					0.27
Softening Point (°C)		Specific Gravity (at 25°C)				Water Content, %			Kinematic Viscosity, (at 135°)cSt		
46.3	a. pycnometer (gm)	23.09				a.Bitumen wt.(100 gm)	67		Time (sec)	10	
	b. pycnometer+wat. (gm)	73.697				b.xylene (40%) (gm)	33		Constant	4.300	
	c. pyc+samp. (gm)	53.984				c.Water Vol. (ml)	0.2		Size No.		
	d. pyc+samp.+wat.(gm)	74.381				Water Content (C*100/a) =	0.30		Serial No.	1202A	
	e. samp.(c-a) (gm)	30.894							Viscosity =	460	
sp.Gr. e/(e+c-d)=		1.023									
Absolute Viscosity,(at 60°C) Poise		B		C							
Time (sec)	37		123								
Constant	56.1260		17.9000								
Size No.	13										
Serial No.	8980										
Viscosity =	2076.662		2201.7								
Average:	2139.2										

Total Tests done of Bitumen

# Bitumen Tests

Tests	Results	Required Values
Penetration Test	57	Min 45 mm
Ductility Test	100 cm	Min 40 cm
Solubility in Tricholoethylene	99.25%	Min 99%
Loss on Heating	0.270%	$\leq 0.5$
Softening Point Test	47	47
Specific Gravity	1.023	0.98-1.05
Water Content	0.3%	$< 2\%$
Kinematic Viscosity	460	Min 350
Absolute Viscosity	2139.2	2400-3600

# Mix Design



Around 1200 Gram of Pre heated Mix Aggregate and pre heated bitumen were Taken

Different percentage of bitumen ranging from 3.5% to 5.5% each increment of .5 % ( binder content) were mixed with aggregates and Compacted

Mixing Temperature was 160 degree celcius

Asphalt cake was Prepared and left it air dry



# Site Visit to Mulkot



Group Photo at  
Samanantar Plant



Newly Laid Overlay at ch  
94+000



Batching Plant



Samanantar Plant



PI Bridge at Narke

# Mix Design

His Majesty's Government  
Ministry of Physical Planning & Works  
Department of Roads  
**Central Road Laboratory**  
**MARSHAL MIX DESIGN**

Project/Office: \_\_\_\_\_ 25°C

$$D = \frac{M}{V}$$

$$M = D \times V$$

Specimen No.	% Bitumen	Thickness (mm)	Wt. in air gm.	Wt. in water gm.	Wt. of SSD sample gm.	Flow		Stability		
						Initial Div.	Final Div.	Division	Kg.	Corrected in Kg.
1	3.5%	67.0 + 66.7 + 66 = 200	1195.6	693.7	1205.7		2.66 mm		12.6 KN	
12)	3.5%	66 + 65.3 + 67 = 198.3	1193.5	686.2	1201.1		2.81 mm		14.1 KN	
13)	3.5%	67 + 65.7 + 66.4 = 199.1	1187.8	679.8	1201		2.93 mm		7.9 KN	

Checked by \_\_\_\_\_



Sample Thickness, Weight, sp Gravity and Stability were taken

Sample cake for 3.5 % bitumen Content

# Bitumen Extraction test

What men's filter paper  
Designed for bitumen test

Nepal Government  
Ministry of Physical Planning and works  
Department of Roads  
**CENTRAL ROAD LABORATORY**  
Tel : 5-521

**Worksheet For Extraction of Bitumen  
PROCEDURE No. 2** D 2172

Operator:..... Project:.....  
Date :..... Sample No. ....

EXTRACTION OF AGGREGATE

A1	Weight of pan + Sample	2648.90	gm
A2	Weight of pan ( bowl )	1501.4	gm
A	Weight of Sample = A1 - A2	1167.5	gm
B1	Weight of pan + Dry sample from Bowl after Extraction	2539.80	gm
B2	Weight of pan	1502.10	gm
B	Weight of dry sample from bowl After Extraction = B1 - B2	1037.70	gm
C	Weight of Dry filter ring After Extraction	11.03	gm
D	Weight of dry filter ring before Extraction	10.20	gm
E	Weight of Aggregated in filter ring = C - D	0.83	gm
F	Total Weight of extracted Aggregate = B + E	1038.53	gm

MINERAL MATTER IN EXTRACT

G	Weight of dry Centrifuge Cup after centrifuging	252.80	gm
H	Weight of dry centrifuge cup before centrifuging	209.0	gm
I	Weight of mineral matter in extract	43.80	gm

WATER CONTENT

L	Moisture content of sample from test D1461	-	%
M	Weight of water in sample = (LxA) ÷ 100	-	gm

BITUMEN CONTENT

J	Weight of aggregates + minerals in sample = F+I	1082.33	gm
K	Weight of bitumen in sample = A - J - M	84.77	gm
	Bitumen content = $\frac{K}{A} \times 100\% = \dots \times 100$	7.26	%



Bitumen Content=7.26%

# Mix Design

	Tot Mix	% of Bit	wt Bit gm	Wt Agg	20 mm 24	16 mm 16	10 mm 24	Dust 36	Total
1	1200	3.5	42	1158	277.92	185.28	277.92	416.88	1158
2	1200	4.0	48	1152	276.48	184.32	276.48	414.72	1152
3	1200	4.5	54	1146	275.04	183.36	275.04	412.56	1146
4	1200	5.0	60	1140	273.6	182.4	273.6	410.4	1140
5	1200	5.5	66	1134	272.16	181.44	272.16	408.24	1134

SN	% Bitumen content	Flow Value mm	Average Flow value mm	Stability KN	Average Thickness mm	Correction Factor	Corrected Stability KN	Average Stability KN	Remarks
1	3.5	2.66		12.60	66.57	0.895	11.28		
2	3.5	2.81	3.133	14.10	66.10	0.905	12.76	10.38	
3	3.5	3.93		7.90	66.37	0.900	7.11		
1	4	3.17		11.00	63.37	1.005	11.06		
2	4	3.59	3.410	10.80	65.90	0.910	9.83	9.59	
3	4	3.47		8.80	66.60	0.895	7.88		
1	4.5	3.14		13.80	64.41	0.949	13.10		
2	4.5	2.67	2.797	14.30	65.53	0.920	13.16	12.12	
3	4.5	2.58		11.00	65.53	0.920	10.12		
1	5	3.25		11.30	62.93	1.105	12.49		
2	5	2.99	3.323	11.10	62.45	1.025	11.38	12.84	
3	5	3.73		14.30	62.47	1.025	14.66		
1	5.5	3.39		9.60	63.50	1.000	9.60		
2	5.5	2	2.607	12.30	63.03	1.010	12.42	11.48	
3	5.5	2.43		13.00	64.10	0.956	12.43		

Mix Design Type:Dense Bituminous Macadam (DBM)

S.N.	% Bitumen	Sp.Gr. Of 25 mm down aggregate	Sp.Gr. Of 16 mm down aggregate	Sp.Gr. Of 10 down mm aggregate	Sp.Gr. of dust	Sp. Gr. of agg. mix	% agg. Mix	Density of comp.Mix gm/cc	Max Sp.Gr	Theoretical Sp Gravitiy	% Air voids	% VMA	% VFB	Sp.Gr. of bitumen	Remarks
1	3.5	2.639	2.636	2.653	2.686	2.659	96.5	2.311	2.518	2.518	8.229	16.1	49.0	1.023	
2	4.0	2.639	2.636	2.653	2.686	2.659	96.0	2.319	2.499	2.499	7.215	16.3	55.7	1.023	
3	4.5	2.639	2.636	2.653	2.686	2.659	95.5	2.351	2.480	2.480	5.220	15.6	66.5	1.023	
4	5.0	2.639	2.636	2.653	2.686	2.659	95.0	2.384	2.462	2.462	3.180	14.8	78.6	1.023	
5	5.5	2.639	2.636	2.653	2.686	2.659	94.5	2.375	2.444	2.444	2.829	15.6	81.9	1.023	

# Mix Design

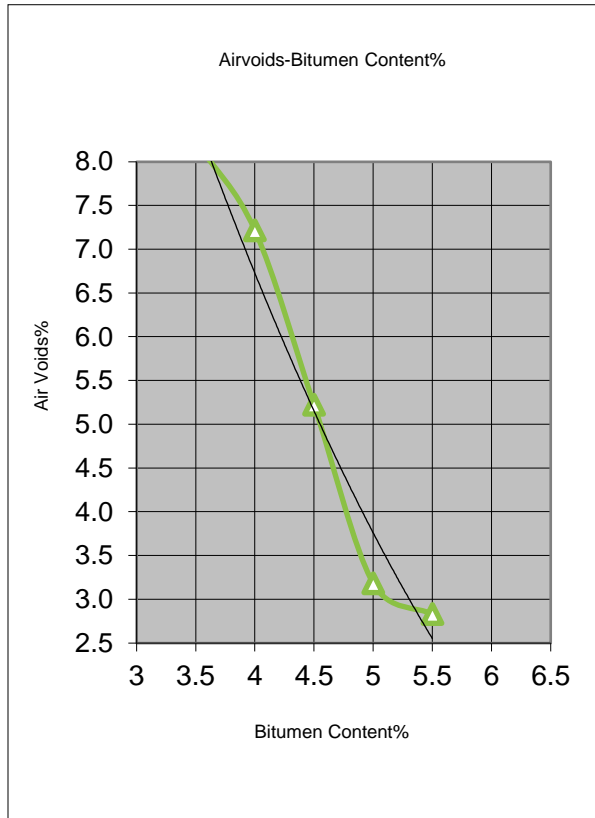

Bitumen content vs Air Voids

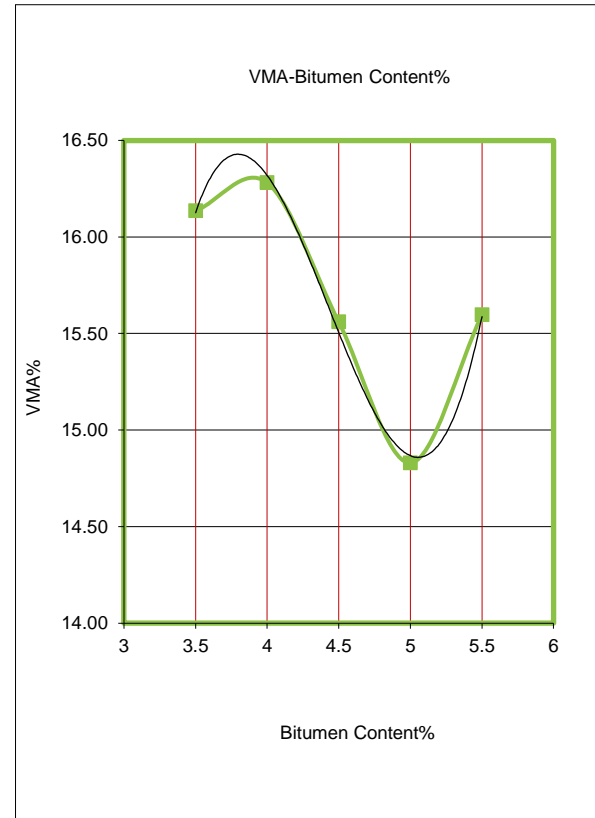

Bitumen content vs VMA

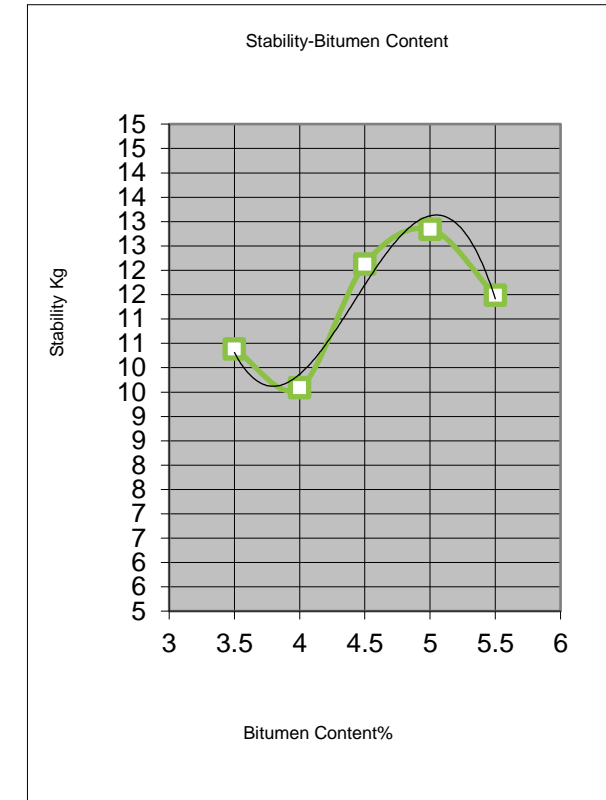

Bitumen content vs Stability

# Mix Design

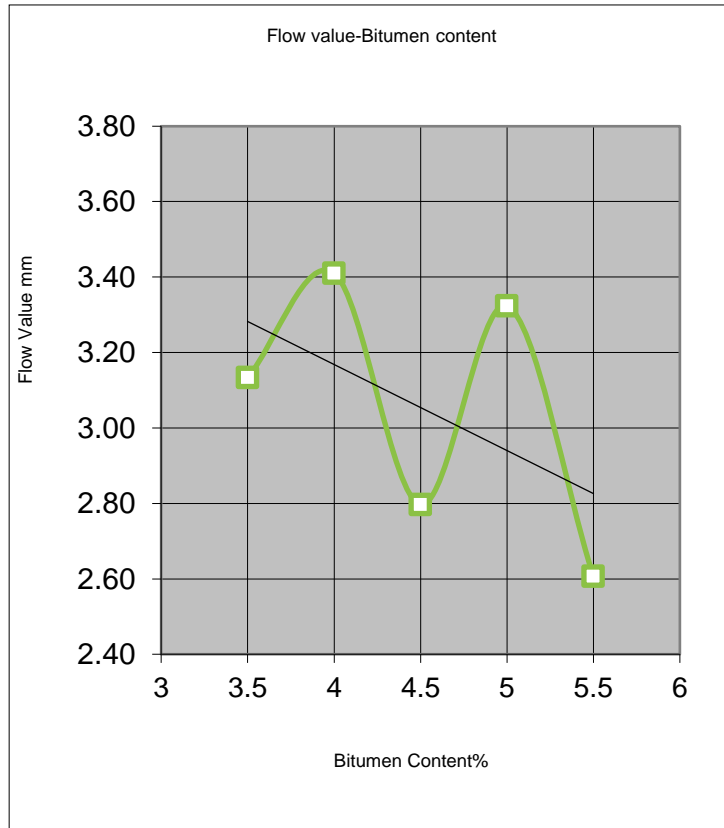

Bitumen content vs Flow Value

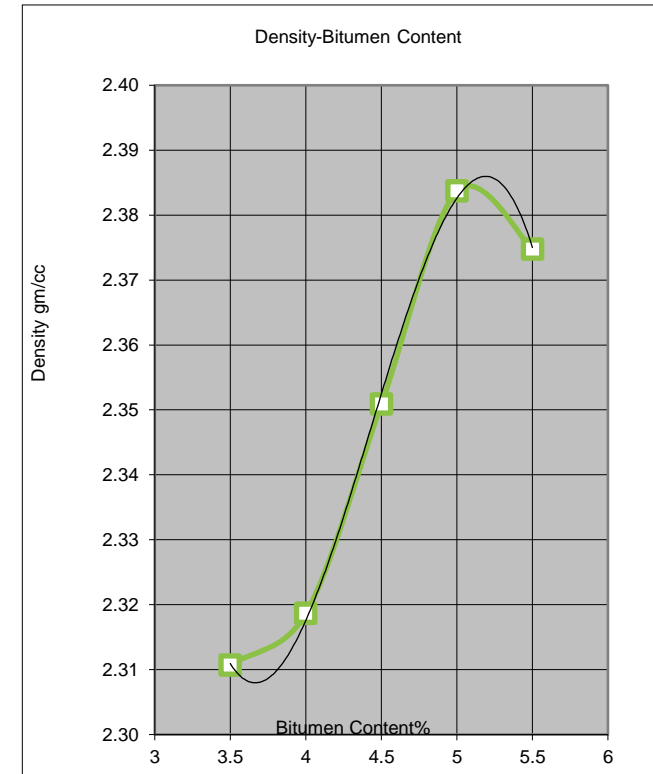

Bitumen content vs Density

# Mix Design

Bitumen content at maximum stability	5 %
Bitumen content at maximum density	5.2 %
Bitumen content at 4.0% air voids	4.95 %
Optimum bitumen content of the proposed asphalt concrete grading	5.10 %
Stability at 5.1% bitumen content=13.0 KN	
Density at 5.1% bitumen content=2.385 g/cc	
Air voids at 5.1% bitumen content=3.5%	
Flow value at 5.1% bitumen content=2.85mm	
VMA at 5.1% bitumen content=14.8 %	

Mix Design

Thank You



नेपाल सरकार  
भौतिक पूर्वाधार तथा यातायात मन्त्रालय  
सडक विभाग



# गुणस्तर अनुसन्धान तथा बिकास केन्द्र चाकुपाट ललितपुर

**Mix design of DBM Grade 2 (50-75 mm) for Kathmandu Valley  
Roads**

14-18 Feb ,2021

प्रस्तुतकर्ता

# बिषयबस्तु

- ✧ **Materials**
- ✧ **Marshall Mix design**
- ✧ **Site Photo**
- ✧ **Problems During Mix Design**
- ✧ **Problems During Construction in ktm Valley**

# Materials

## A. Bitumen

➤ **VG 30** (Highest Daily Mean Air Temperature more than 30)

### Test of Bitumen

1. Penetration
2. Flash & Fire
3. Softening Point
4. Specific Gravity
5. Water content
6. Viscosity
7. Loss on heating

## B. Aggregates

- Coarse Aggregates(37.5 -2.36)
- Fine Aggregates (2.36-0.075)
- Filler (0.6-0.075)(Rock dust,Hydrated lime,Cement)

### Test of Aggregates

1. LOS angeles Abrasion Test
2. Aggregates Impact Value
3. Flakiness/Elongation Index
4. Specific Gravity & Water Absorption
5. Aggregates Crushing Value

# Sieve Analysis of Aggregates

- Sieve Analysis test results of the Provided Sample
- Sieve Analysis Of the mix aggregates job mix(Agg% of Mix)
  1. 20 mm down Aggregates=....%
  2. 16 mm down Aggregates=....%
  3. 10 mm down Aggregates=....%
  4. Filler material(dust) =....%

# Design process

- 5 Trials(1200 gm) mix proportion for mix design of DBM(Agg+bitumen)
- Average density of compacted mix
- specific gravity of mix
- % Air voids, % VMA, % VFB,Av. Flow Value,Av. Stability

# Draw Graphs and calculation of optimum bitumen content

- Air Voids% vs Bitumin content%,VMA% vs Bitumin content %,Stability vs Bitumin content %,Flow value vs Bitumin content %,Density vs Bitumin content %
- Bitumin content is Average of (Max.Stability+Max. density+4% air void)
- Check Stability,Density,Air voids,Flow value,Vma

# Site Photos



# Problems During Mix Design

- **Nonconformity of Quality of Bitumin**
- **Mostly VG 10 Bitumin is used**
- **Only stone dust is used As Filler**

# Problems During Construction in Ktm Valley

## ➤ Quality of Materials( Bitumin,Aggregates,Filler)

mostly vg 10 is used

( LA,AIV,ACV) of Agg ,Quality of Filler(Only stone dust is Used),Sufficient Filler is not used

Mixing Temperature

Laying Temperature, Joints, Rolling

## Some Facts about Asphalt Test

### STANDARD SPECIFICATIONS FOR ROAD AND BRIDGE WORKS-2073

#### 1308 DENSE BITUMINOUS MACADAM

##### Aggregate Grading and Binder. Content

(i) When tested in accordance with IS:2386 Part 1 (wet sieving method), the combined grading of the coarse and fine aggregates and filler for the particular mixture shall fall within the limits given in Table 13.28 for grading 1 or 2 as specified in the Contract. **To avoid gap grading, the combined aggregate gradation shall not vary from the lower limit on one sieve to higher limit on the adjacent sieve.**

**Nominal aggregate size\*** :- The nominal maximum particle size is the largest specified sieve size upon which any of the aggregate is retained

**Table 13.28: Composition of Dense Graded Bituminous Macadam**

Grading	1	2
Nominal aggregate size*	35.5 mm	26.5 mm
Layer thickness	75-100	50-75
IS Sieve <sup>1</sup> (mm)	Cumulative % by weight of total aggregate passing	
45	100	
37.5	95-100	100
26.5	63-93	90-100
19	-	71-95
13.2	55-75	56-80

### 3) Mix Design

**(b) Binder Content :-** The binder content shall be optimized to achieve the requirements of the mix set out in Table 13.30. The binder content shall be selected to obtain 4 percent air voids in the mix design. The Marshall method for determining the optimum binder content shall be adopted as described in the Asphalt Institute Manual MS-2.

Where maximum size of the aggregate is more than 26.5 mm, the modified Marshall method using 150 mm diameter specimen described in MS-2 and ASTM D 5581 shall be used. This method requires modified equipment and procedures.

### MS-2

The nominal maximum aggregate size is one size larger than the first sieve to retain more than 10 percent of the material. Maximum aggregate size (MAS) is one size larger than nominal maximum's size.

### *Marshall Method of Mix Design*

- In most cases, the optimum binder content should be selected for which the compacted specimens have 4 percent air voids.
- The original Marshall method is applicable only to hot mix asphalt paving mixtures containing aggregates with maximum sizes of 25 mm (1 in.) or less. **A modified Marshall method** has been developed for aggregates with maximum sizes up to 38 mm (1.5 in.). Procedures for 6-inch diameter specimen are given by ASTM D5581

The smallest sieve opening through which the entire amount of aggregate is **required to pass** is called the **maximum size**.

The smallest sieve opening through which the entire amount of aggregate is **permitted to pass** is called the **nominal maximum size**. May retain **10%** of total weight of aggregate.

**For example**, for the aggregate meeting the specification limits shown below would have a **maximum size of 37.5 mm** (1-1/2 in.) and a **nominal maximum size of 25.0 mm** (1 in).

Sieve Size	Specification limits: percentage passing
37.5 mm	100
25 mm	95-100
12.5 mm	25-60
4.75 mm	0-10
2.36 mm	0-5

धन्यवाद



# CERTIFICATE OF PARTICIPATION



Issued by

Department of Roads, Quality Research and Development Center (QRDC)

In cooperation with

Project for the Operation and Maintenance of Sindhuli Road Phase 2 (SROM2)  
JAPAN INTERNATIONAL COOPERATION AGENCY (JICA)

Mr.

For participating in the training

“Asphalt Concrete Mix Design and Quality Control  
in Pavement Construction”

(14<sup>th</sup> Feb 2021 ~ 18<sup>th</sup> Feb 2021)

Dr. Bijaya Jaishi  
Director  
Quality Research and  
Development Center (QRDC), DoR

Er. Ram Hari Pokharel  
Deputy Director General  
Development Cooperation Implementation  
Division (DCID)

Er. Arjun Jung Thapa  
Director General  
Department of Roads (DoR)

**The Project for  
Operation and Maintenance of  
The Sindhuli Road Phase 2**

**Report  
On  
Domestic Technical Tour at  
Nagdhunga Tunnel Construction Project  
(One Day Tour)**

**June 2022  
JICA Expert Team**

- Table of Contents -

- <b>1</b>	<b>Outline of the Technical Tour .....</b>	<b>1</b>
1.1	Background.....	1
1.2	Objectives .....	1
1.3	Selection of Destination .....	1
1.4	Arrangement for the Tour .....	1
1.5	Participants .....	2
1.6	Tour Venue .....	2
- <b>2</b>	<b>Tour Program .....</b>	<b>4</b>
- <b>3</b>	<b>Report of Tour Implementation.....</b>	<b>4</b>
3.1	Lectures in the Consultant’s Office .....	4
3.2	Site Visit to Tunnel Construction .....	6
- <b>4</b>	<b>Conclusions of the Technical Tour.....</b>	<b>8</b>
4.1	Comments from DOR.....	8
4.2	Conclusions and Recommendations .....	8

## **1 Outline of the Technical Tour**

### **1.1 Background**

As envisaged in the Terms of Reference of The Project for Operation and Maintenance of the Sindhuli Road Phase 2 (hereinafter referred to as SROM2), technical study tours are to be organized approximately once or twice to mutually share good practices and lessons learned on project activities with DOR HQ and other regional offices. This tour was organized by DOR, and JICA Expert Team (hereinafter referred to as JET) has supported it in various aspects.

### **1.2 Objectives**

The objective of this tour was to take first-hand information on various activities that are presently undergoing with technical aspects and background that were considered during the design period. The present manpower working under the Sindhuli Road Project will be benefitted from this tour and the knowledge obtained can be utilized in various other future projects.

### **1.3 Selection of Destination**

The destinations and schedule of the tours were decided by JET in consultation with DOR Sindhuli Road Project.

Since the Nagdhunga Tunnel Construction Project, (hereinafter referred as to NTCP), an important transportation Project in Nepal, is one of the interesting projects to visit and observe its activities firsthand. This Project is currently being implemented by the Department of Road, with financial support from JICA (Soft Loan project). JICA has provided a soft loan of about 16 billion JPY to the GON. A Japan-based Consultant Team, JV of Nippon Koei – EJEC-NCC in association with GEOCE and ITECO, is presently engaged for the Detailed Design and Construction Supervision Works. Likewise, M/S Hazama Ando Corporation has been working as the Contractor for this Project.

Since the NTCP is the first transportation tunnel in Nepal, there are several components and activities which are very new. By visiting the NTCP, it is expect to provide trainees with an overview of the tunnel project. Further, the tour will help the trainees in their planning and implementation of similar tunnel projects in other parts of the country in the future.

### **1.4 Arrangement for the Tour**

The Sindhuli Road Project has managed some arrangements for a one-day observation tour (Domestic Technical Tour) after necessary consultation with the Department of Roads, NTCP, and got necessary permission to visit the project site of NTCP.

After coordinating with the respective agencies, JET of SROM2 has made the necessary

arrangement for a 1-day tour on June 01, 2022.

## **1.5 Participants**

The Participants for the tour are the employees of Sindhuli Road Project who are presently working for the Project. The JET members also participated in the the Tour.

As Attached herewith (See **Appendix-1**)

### **1.5.1 Name of Trainees (DOR)**

1. Mr. Shambhu P. Acharya, SDE
2. Mr. Rabindra Shrestha, Engineer
3. Mr. Karna Singh Khatri, Engineer
4. Mr. Ananta Baral, Engineer
5. Mr. Gyanendra Kalaune, Engineer
6. Mr. Gitanjali Koirala, Engineer
7. Mr. Khadka B. Thapa, Account Officer
8. Mr. Manoj Bista, Sub-Engineer
9. Mr. Harischandra Sejuwal, Sub-Engineer
10. Mr. Tejendra Kumar Chand, Sub-Engineer

### **1.5.2 Name of Trainers (NTCP)**

1. Mr. Ramesh P. Koirala, JET Member of SROM2, & Coordinator of NTCP
2. Mr. Ishwar Dahal, Geologist of NTCP

### **1.5.3 Name of Participants**

JET Members of SROM2

1. Mr. Hiroki Shinkai, Chief Adviser,
2. Mr. Tomokuni Hayakawa, Pilot Project
3. Mr. Bindu S. Rana, Road Safety & Project Coordinator
4. Mr. Akhilesh K. Karna, EIS / Disaster Prevention
5. Ms. Natsuko Sagawa, Coordinator / Project Monitoring
6. Mr. Shiva R. Adhikari, Supporting Staff
7. Mr. Yohei Onomura, Assistant Road Safety

## **1.6 Tour Venue**

### **1.6.1 Nagdhunga Tunnel Construction Project, for Lecture and Discussion**

Meeting Hall, Employers Office

Basundol, Chandragiri-2, Kathmandu

(See Photo)

### 1.6.2 Nagdhunga Tunnel Construction Project, for Construction Site Visit

Visit: Eastern Main Tunnel, Eastern Evacuation Tunnel

Address: Basundol, Chandragiri-2, Kathmandu

(See Location Plan below)

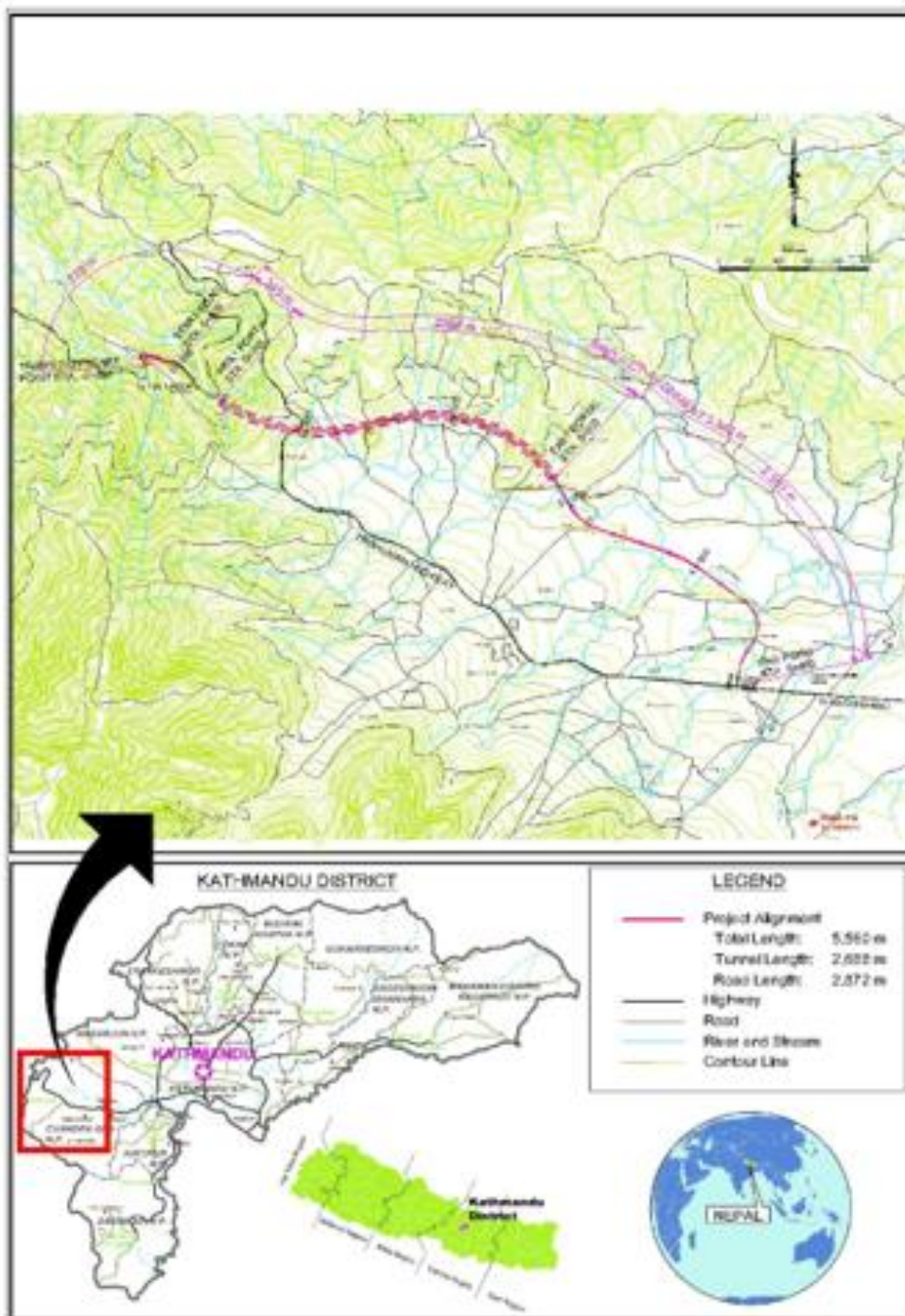

Figure 1-1 Project Location of the NTCP

**2 Tour Program**

Table 2-1 Tour Program

Date June 01, 2022

S No	Activities	Start	End	Duration	Remarks
1	Start from Kathmandu Office	9:00	10:00	1:00 hr	Arrival at NTCP
2	Lecture by the consultant team	10:15	11:15	1:00 hr	Mr. RP Koirala
3	Site Visit to Tunnel Construction Site	11:30	12:30	1:00 hr	Mr. RP Koirala, Mr. Ishwar Dahal
4	Return Back	12:30	13:30	1:00 hr	

**3 Report of Tour Implementation****3.1 Lectures in the Consultant's Office****3.1.1 Lecture Program**

The lecturer of the session, Mr. Ramesh P. Koirala explained, in brief, the project covering the investigation, planning, and design. At present, the project is in the implementation stage. He presented about the design concepts of the project, that includes basically the following contents:

1. Introduction of the project, project layout and scope
2. Brief about the project components and their arrangement (east & west portals, approaches, structures, tunnels and Michi-no-eki etc.)
3. Survey and Investigation adopted during detail design to finalize the alignment
4. General description of tunnel construction procedure, primary and secondary supports
5. Tunnel facilities and their arrangement
6. Operation and maintenance program, implementation plan
7. Construction monitoring
8. Discussion, Q & A.

**3.1.2 Discussion and Q&A Sessions**

After the presentation about the project information, a few questions were raised by the participants. The questions were responded by the presenter as noted below.

Q How does the Project tackle the traffic that will increase in the future?

A During the feasibility study period, a traffic count survey was conducted and future traffic was also forecasted. The proposed main tunnel (transportation tunnel) is sufficient to serve for the next 15 years. In the same period, the fast track road, which is presently under construction, will share the significant traffic volume of Tribhuvan Highway. But, in the case of a no-fast track situation, the Nagdhunga main tunnel will not be sufficient to cater to all

the traffic. In this case, the present evacuation tunnel needs to be upgraded as a transportation tunnel.

Q What is the O & M plan for NTCP Tunnel?. How the required staff will be engaged? Is there any additional facility like remuneration to the staff?

A An O&M plan has been already approved. A total number of 90 staff will be designated for the operation of this tunnel. The staff will be supplied by DOR, RBN, Police, and local authority. Or, as an alternative, the staff can be employed through outsourcing. Additional facility to these staff is the concern of the Employer.

Q How tunnel movement is being monitored?

A. The tunnel movement is monitored daily by the total stations. Coordinates in all three directions are being recorded. After full stability (movement less than 1mm for 15 days) of the tunnel, the Contractor is allowed for the next activity like lining concrete work.

### 3.1.3 Photographs of Lectures

Scenes of presentation and discussion is shown in the photos below.



Figure 3-1 Photo of Lecture Program delivered by Mr. R. P. Koirala

## **3.2 Site Visit to Tunnel Construction**

### **3.2.1 Site Visit Program**

Immediately after the lecture session, all the participants wore the PPEs (Personal Protective Equipments) and proceeded to the east portal area. A small discussion was made at the eastern portal area that was related to the safety rules that must be followed inside the tunnel. The participants then entered the tunnel following the track assigned only for the pedestrian. The participants observed the activities that were ongoing inside the tunnel covering especially the concrete lining works, waterproofing installation works, and drilling works at the face. The team also visited the evacuation tunnel while returning. Finally, the lecturer answered the questions of the participants one by one.

### 3.2.2 Photographs of Site Visit

Scenes of site visit is shown in the photos below.

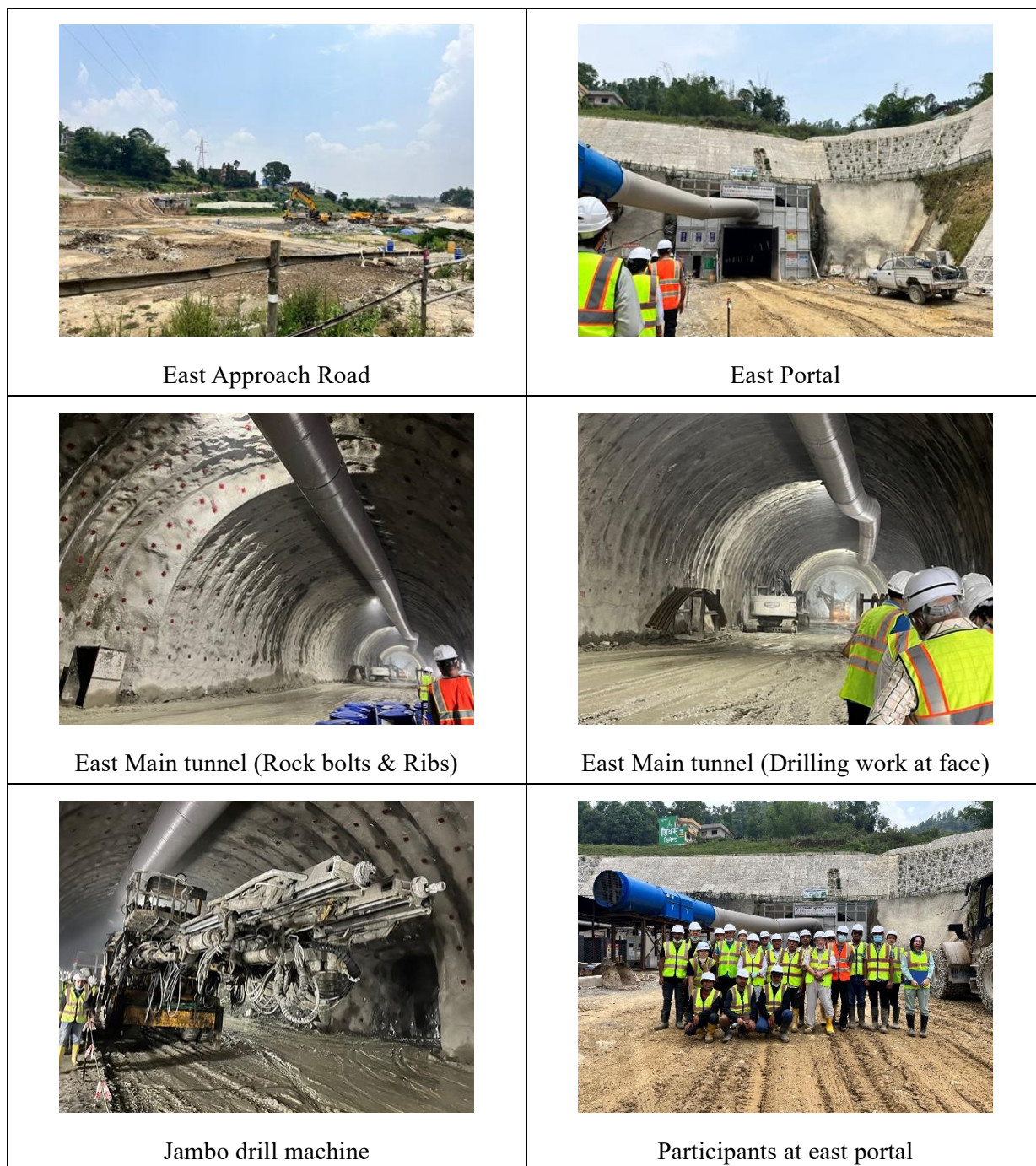

Figure 3-2 Photo of Site Visit

## **4 Conclusions of the Technical Tour**

### **4.1 Comments from DOR**

The participants from DOR expressed their happiness for being a participant in this tour. According to them, the knowledge and experience of this training will be useful for future mountain tunnel projects. They thanked everyone, including JET and NTCP, for arranging this training program. However, after visiting the eastern main tunnel and evacuation tunnel on the east side, most of the participants said that they could not cover the entire activities that have been going on under this project, especially the west side. Apart from this, the participants appreciated the quality and workmanship of the project.

### **4.2 Conclusions and Recommendations**

The Chief Advisor, JET of SROM2, Mr. Shinkai thanked positive participation from DOR and warm acceptance by the NTCP team and appreciated the great benefits of this visit. He further concludes that this tour was very informative to enhance wide knowledge of DOR engineers.

On the other hand, there are several components of the Project. For example, construction of approach road, roadside service station (Michi-no-eki), disposal embankment, and west portal on the west side. Likewise, the east portal, east approach road, and various structures including the Balambu flyover. The east and west parts are connected by main tunnel and evacuation tunnel. It is regretted that a half-day tour is not sufficient to cover and understand the project entirely. If the opportunity arises, it would be useful to plan a comprehensive tour that includes the western part of the construction site that was missed.

The tour ended at 12:30 pm and participants and JET members proceeded to their respective offices.

Attachement 1 - Participant list (Signature)

Attachement 2 - Presentation Materials

**(see Separate File)**

Event : Visit from Sindhuli Road Project.

Venue : Nagdhunga Tunnel Project Area.

Date : 1-Jun-2022

**Attendance List.**

S. No.	Names	Organization	Position	Signature
1	Harishchandra Seyuwal	DOR	Sub-Engineer	Harish
2	Tejendra Kumar Chand	DOR	Sub-engineer	T. Chand
3	Rabindra Shrestha	DOR	Engineer	R. Shrestha
4	Karna Singh Khatri	DOR	"	K. Singh
5	Ananta Baral	DOR	"	A. Baral
6	Gyanendra Kalaunee	DOR	"	G. Kalaunee
7	Manoj Bista	DOR	sub,engineer	M. Bista
8	Gitanjali Koirala	DOR	engineer	G. Koirala
9	Shiva Raj Adhikari	DOR NK	JET	S. Adhikari
10	Natsuko Sagawa	JET/NK	Coordinator	N. Sagawa
11	Bindu S. Rana	JET	Coordinatore	B. Rana
12	Shambhu pd. Acharya	DOR	C.D.E.	S. Acharya
13	Hiroki SHINKAI	JICA	Chief Advisor	H. Shinkai
14	Tomokuni Hayakawa	JICA	Road Planner	T. Hayakawa
15	Yohei Onomura	JICA	Coordinator	Y. Onomura
16	Akhilesh Kumar Karna	JICA, SRMZ	ES Expert	A. Karna
17	Khodka bds thapa	SRMZ	Account Officer	K. Thapa
18	Danul P Karale			D. Karale
19				
20				
21				
22				
23				
24				
25				

Loan Agreement No. : [NE-P10]  
Contract No. : [NTCP-DOR-S-QBS-01]

Consulting Services for  
Detailed Design and Construction Supervision of  
**Nagdhunga Tunnel Construction Project**

# Presentation of update status

Final Outcome of Tunnel Design

Nov, 2019 (original presentation 17 April 2018)

The Joint Venture of



Eight-Japan Engineering Consultants Inc.  
Nippon Civic Consulting Engineers Co., Ltd.

In Association with



ITECO Nepal (P) Ltd.

1

## Agenda

- |  |   |
|--|---|
| 1. OBJECTIVE & PROGRESS OF NAGDHUNGA TUNNEL CONSTRUCTION PROJECT (NTCP)                | Mr. Hidefumi EZAWA, Team Leader                                       |
| 2. COMPONENTS AND FEATURES OF NTCP   | Dr. Naresh STHAPIT, Sr. Highway Engineer                              |
| 3. Roadside service center   | Mr. Utshav SUBEDI, Highway Engineer                                   |
| 4. PLANNING, INVESTIGATION, DESIGN, CONSTRUCTION AND OPERATION & MAINTENANCE OF TUNNEL |   |
| 4.1 PLANNING   | Mr. Satoshi WASHIO, Tunnel Planner<br>(Mr. Hiromi YAMAGAI, Geologist) |
| 4.2 SURVEY AND INVESTIGATION   | Dr. Vishnu DANGOL, Geologist<br>Mr. Hiromi YAMAGAI, Geologist         |
| 4.3 DESIGN   | Mr. Teppei TOMITA, Tunnel Engineer                                    |
| 4.4 TUNNEL FACILITIES  | Mr. Teppei TOMITA, Tunnel Engineer                                    |
| 4.5 COST ESTIMATE  | Mr. Takuya KURAMOCHI, Sr. Quantity Surveyor                           |
| 4.6 CONSTRUCTION   | Mr. Hidefumi EZAWA, Team Leader                                       |
| 4.7 OPERATION & MAINTENANCE  | Mr. Ramesh P. KOIRALA, Coordinator                                    |
| 5. FURTHER SCHEDULE  | Mr. Achyut BHATTA, Deputy Team Leader                                 |

2

## 1. Objective of the Project

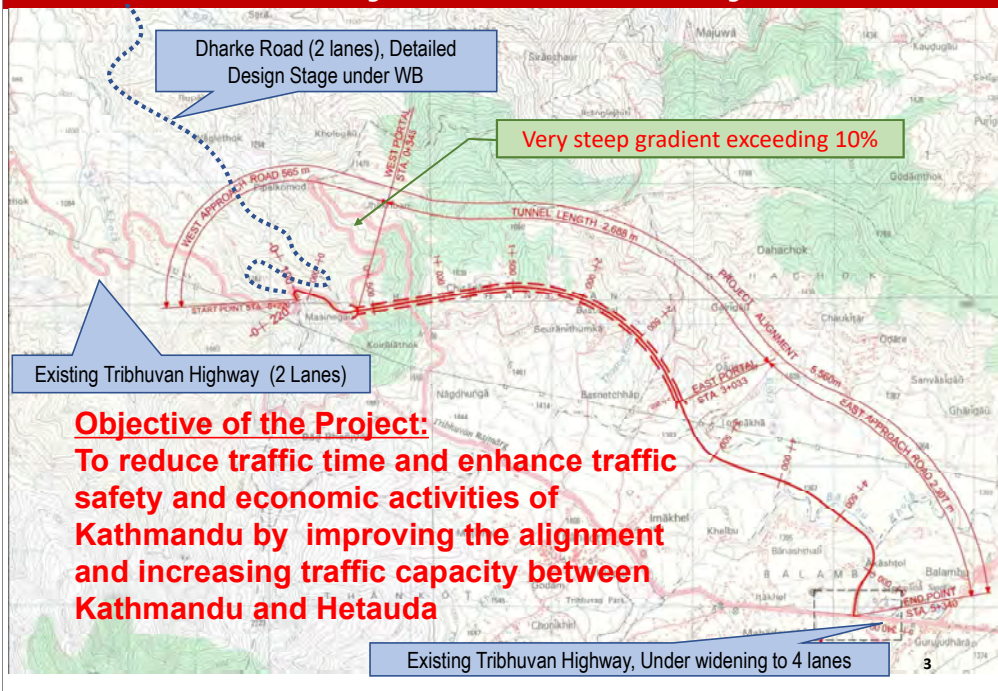

3

## Progress up to date

- Pre-feasibility Study (JICA) January 2014
- Feasibility Study (JICA) March 2015
- Loan Agreement (Between GON and JICA) December 2016  
*Japanese ODA loan: 16.636 billion yen*
- Request for Proposal for Consulting Service December 2016
- Signing on Agreement for Consulting Service March 2017
- Commencement of Consulting Service April 2017
- Submission of Final Design Report April 2018

(Original target: March 2018)

4

## 2. Components & Features of NTCP

- Changes in scope

Project Components	Features	TOR	Detailed Design
<b>1. Construction of Tunnel</b>			
Tunnel Alignment	Length (km)	2.45	2.688
	Gradient (%)	3.22	3.5
Tunnel Cross Section	Number of lanes	2 (+1)	2
	Lane Width (m)	3.5	3.5
	Median Width (m)	0	1.5
	Total Width (m)	10.5	9.5
Ventilation System	No. of Jet Fans	28	15
Emergency Evacuation System	Evacuation Tunnel	Embedded shelter	Separate Tunnel
<b>2. Construction of Approach Road</b>			
Intersection at West (BP)	Intersection at West	No	Dharke Road Int.
Service Road at East	Service Road	No	2.2km in total
Intersection at East (EP)	Grade Separated with Flyover	No	L = 128m
<b>3. Construction of Bridges along Approach Road</b>			
Bridges along Approach Road	No. of Bridges	2	3
	Underpass	0	2
	Overpass	0	1
	Flyover	0	1

5

## Components & Features of NTCP

- Changes in scope

Project Components	Features	TOR	Detailed Design
<b>4. Construction of Toll Facility</b>			
Semi-automatic Toll Booths	West Toll Plaza	3	3
	East Toll Plaza	2	2
<b>5. Construction of Control Office</b>			
Sizes changed	West Portal	390 m <sup>2</sup>	616.5 m <sup>2</sup>
	East Portal	300 m <sup>2</sup>	1440.5 m <sup>2</sup>
<b>6. Disposal Area Development</b>			
Disposal Area & Michi-no-eki separated	Parking Space	994 m <sup>2</sup>	3015 m <sup>2</sup>
	Toilet	78 m <sup>2</sup>	240 m <sup>2</sup>
	Restaurant	194 m <sup>2</sup>	312 m <sup>2</sup>
	Shops	135 m <sup>2</sup>	312 m <sup>2</sup>
	Greenery	290 m <sup>2</sup>	2743 m <sup>2</sup>
<b>7. Construction of Transmission Line</b>			
Alignment changed	Length	4.14 km	4.23 km

6

## TUNNEL CROSS SECTION

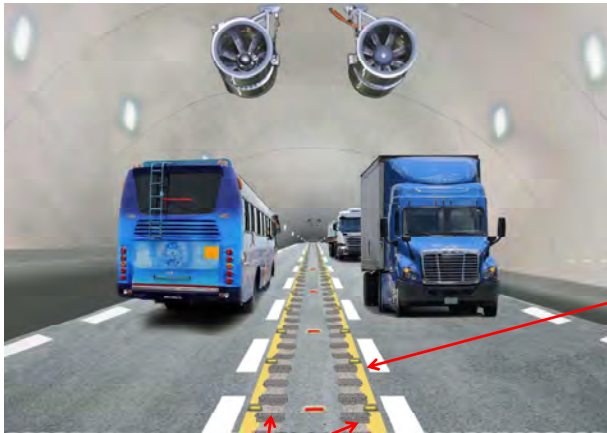

Rumble Strip with Road Studs

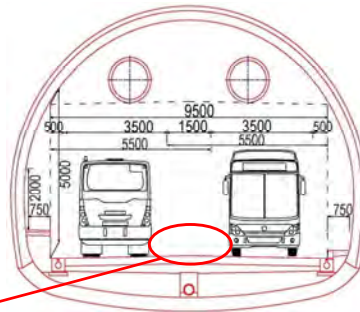

7

## West Portal

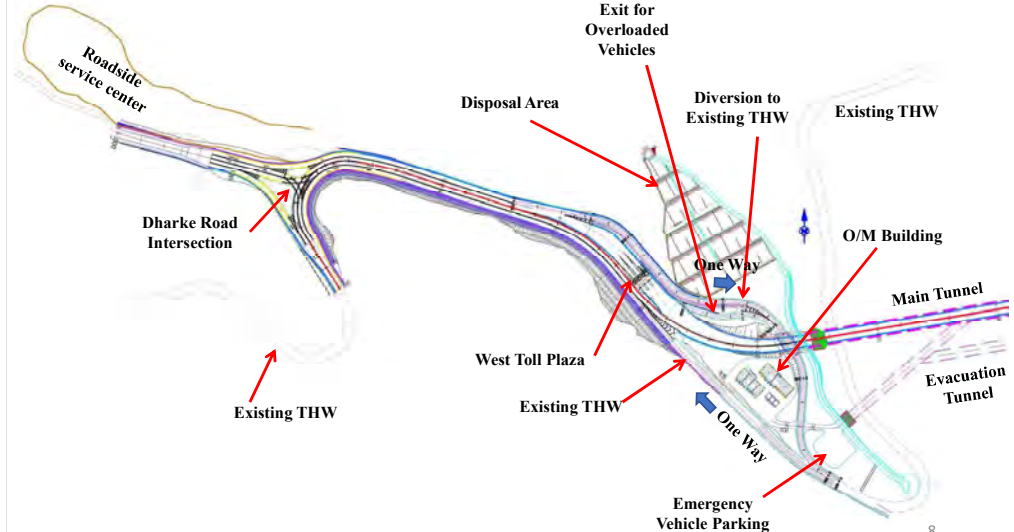

8

## West Portal



9

## West Portal



10

## East Portal

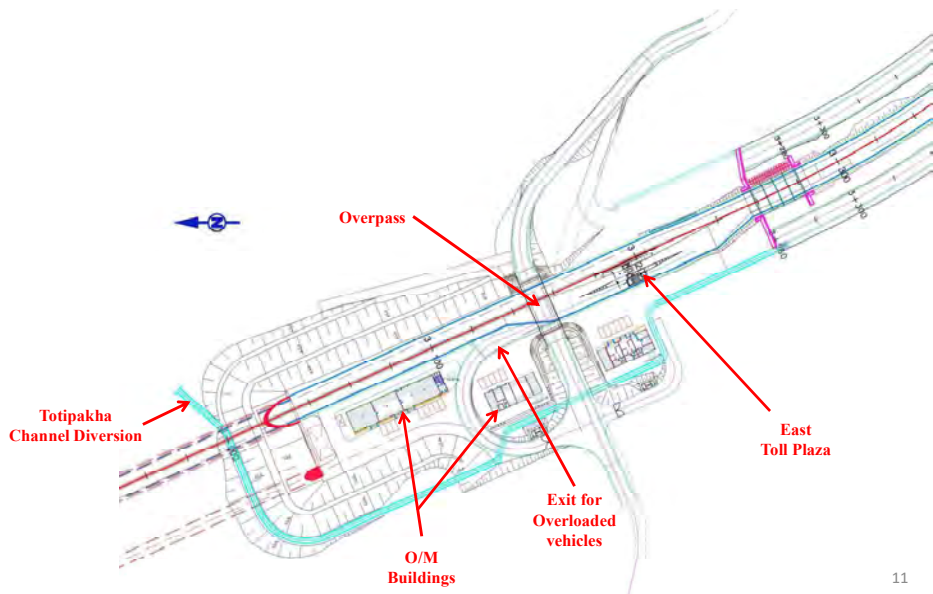

11

## East Portal



12

# Balambu Interchange Flyover

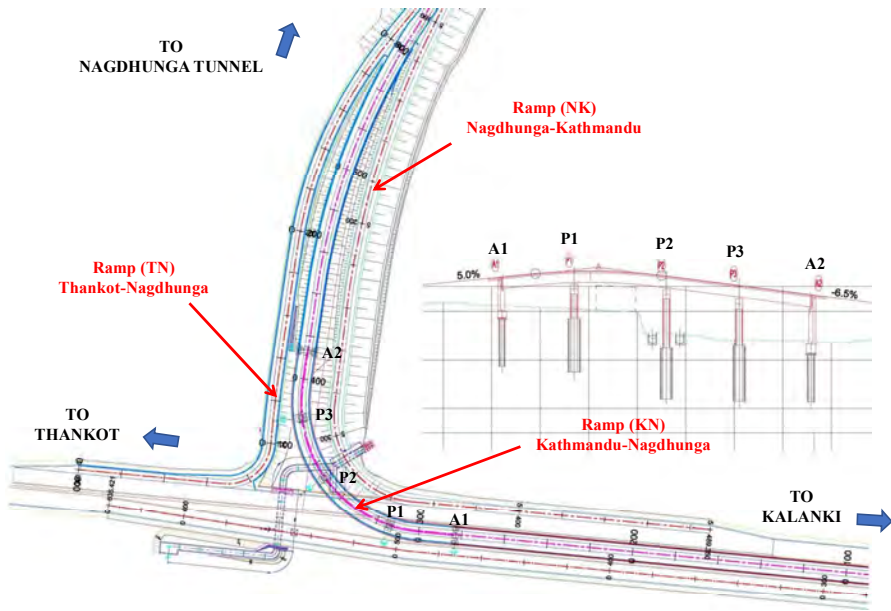

13

# Balambu Interchange Flyover



14

# Balambu Interchange Flyover



15

## 3. Roadside service center

**Roadside service center** is facility/space for rest and other facilities which will provide services to the road users as well as provide opportunities to sell local products.

Roadside service center has three distinct features

Refresh  
(Safety)

Community

Information

**Refresh** – Provides road users with comfortable and hygienic places to rest.

**Community** – Provides local producers with opportunities to sell local specialties.

**Information** – Road/Tunnel, tourist and emergency care information is readily available.

16

## Proposed Location

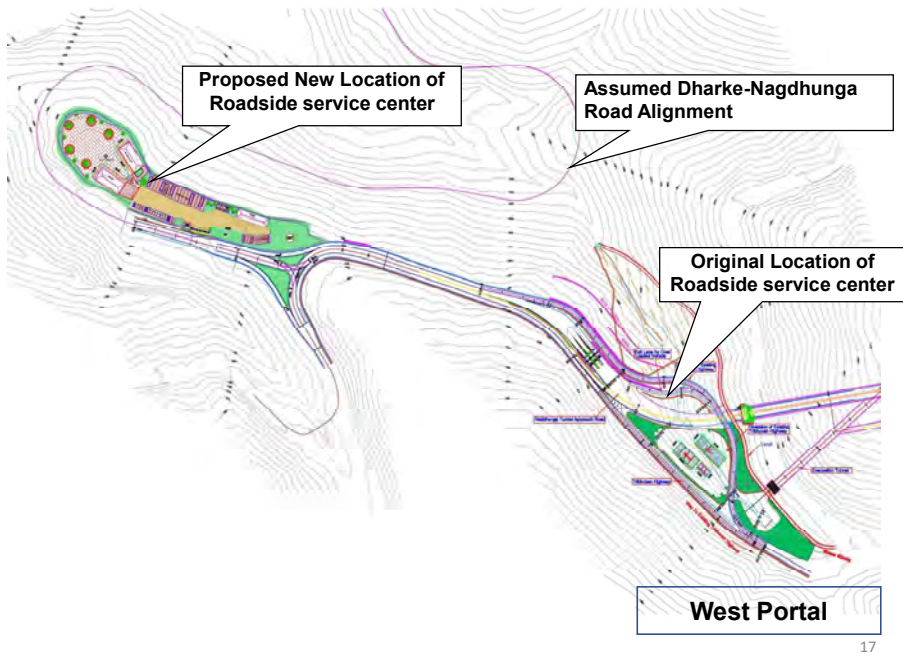

## Layout Plan of Roadside Service center

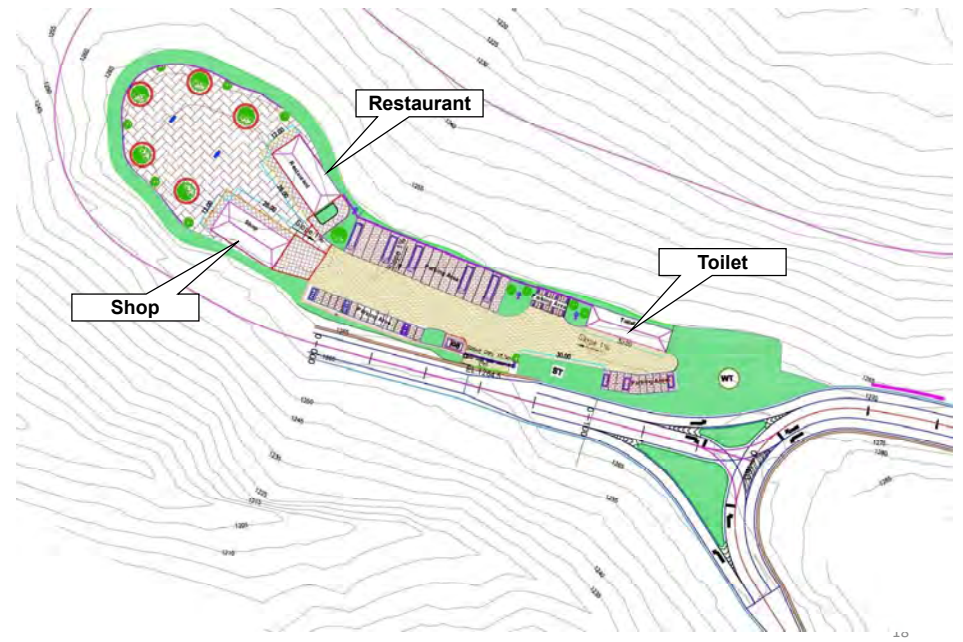

## Perspective View of Roadside service center



## 4.2 (3) Core Drilling and Ground Classification

### Example for Meta-sandstone Main Portion 【VB-3 (45 – 180m)】



Rock Quality Designation (RQD): 10-40% (CII), 40-70% (CI), 70-100% (B)  
 Ground Classification: ~104m: CII Class, 104~(180m): CI Class

## 4.2 (4) Geological Section by MAM (Microarray Measurement)

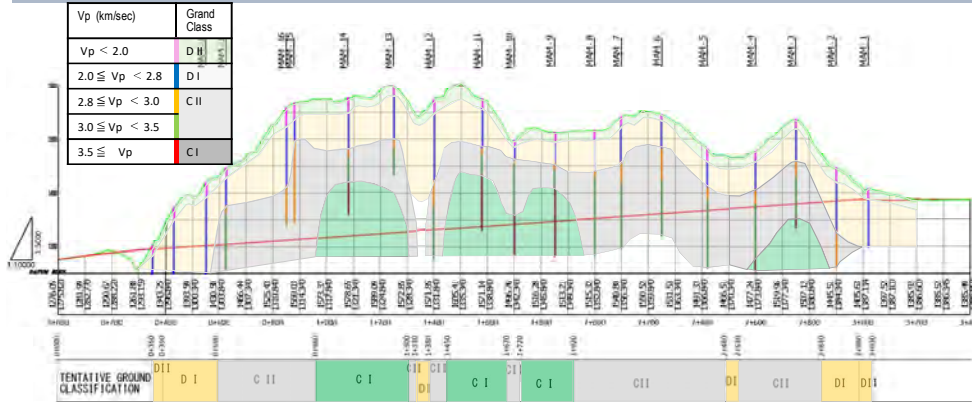

- MAM was adopted as a rapid method for rough estimation of P-wave distribution. By this measurement, the proposed alignment was estimated as better ground classification as a whole length than the previous alignment in the Preliminary Study.  
**D class: 938→530m, CII class (1,512m)→ CII class (1,410m)+ CI class (740m)**
- As This is a TENTATIVE classification upon Vp assumed from MAM, the detailed Seismic profiling was required for the detailed Tunnel Design.

21

## 4.2 (5) Results of Electrical Resistivity Tomography

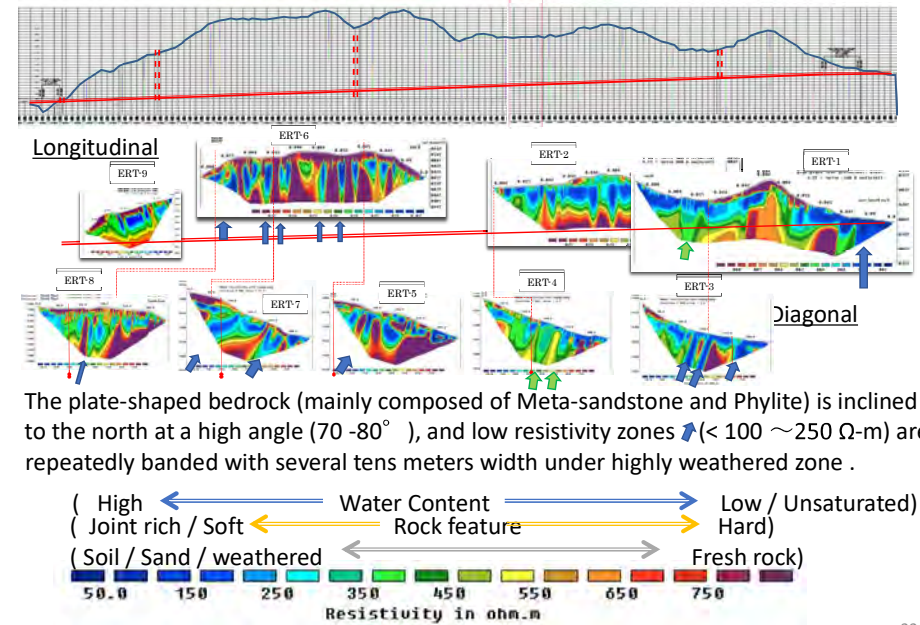

22

## 4.2 (6) Results of Seismic Refraction Tomography

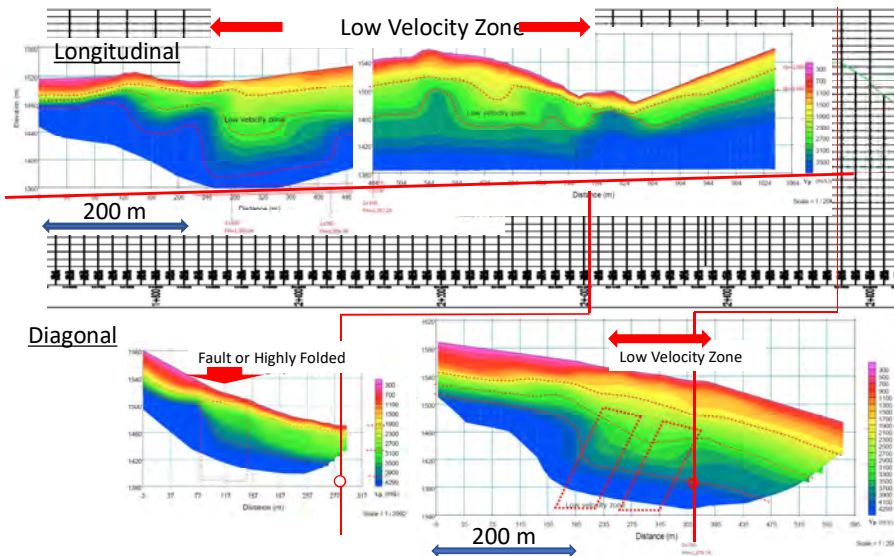

Note: As the high velocity layers may be sandwiched in lower velocity layers with highly inclining, the depth of high velocity layer is analyzed shallower than the actual depth on the vertical profiling section.

23

## 4.2 (7) Geological Map and Structure of Base Rocks

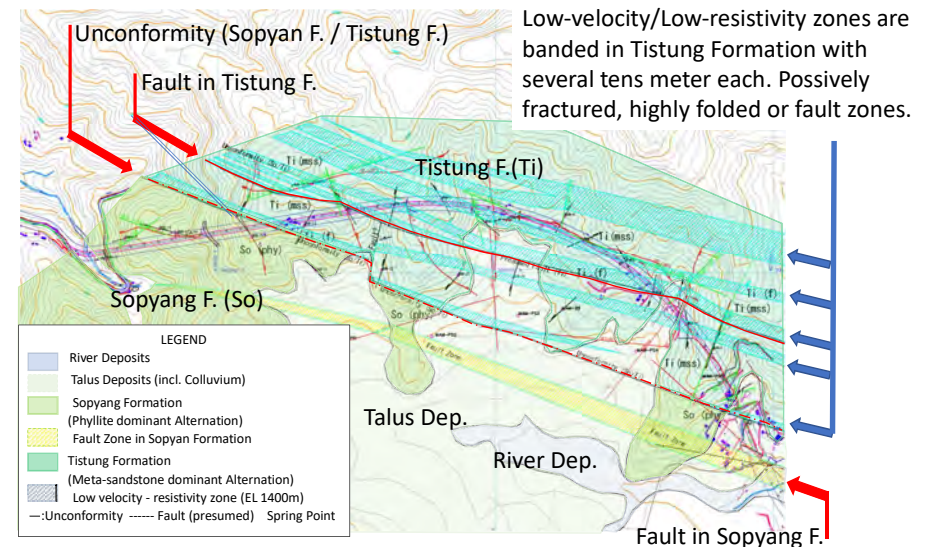

24

## 4.2 (8) Geological Section by ERT, SRT and Boring

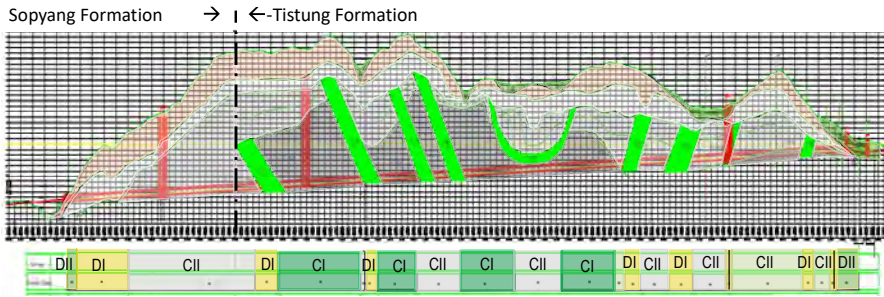

Vp (km/sec)	Ground Class
Vp < 2.0	Colluvial Soil
Vp < 2.0	DII
2.0 ≤ Vp < 3.0	DI
3.0 ≤ Vp < 4.0	CII
4.0 ≤ Vp	CI
Vp < 3.0 ~ 3.5	DI - CII (Fractured/Folded)

➤ Though this Ground Classification is similar to MAM's results in general, the low-velocity and low-resistivity zones were detected as some bands in Tistung Formation and evaluated as DI or CII even in enough deep less weathered.

➤ Notes: In the layered rock such as in the project area, the ground class shall be evaluated 1 rank lower than the classes for a massive rock in accordance with P-wave velocity, because the wave passes selectively in high velocity layer in the vicinity.

25

## 4.2 (8) Hydro-geological Features

➤ Area of possible groundwater lowering was estimated upon the geomorphological feature for the tunnel alignment.

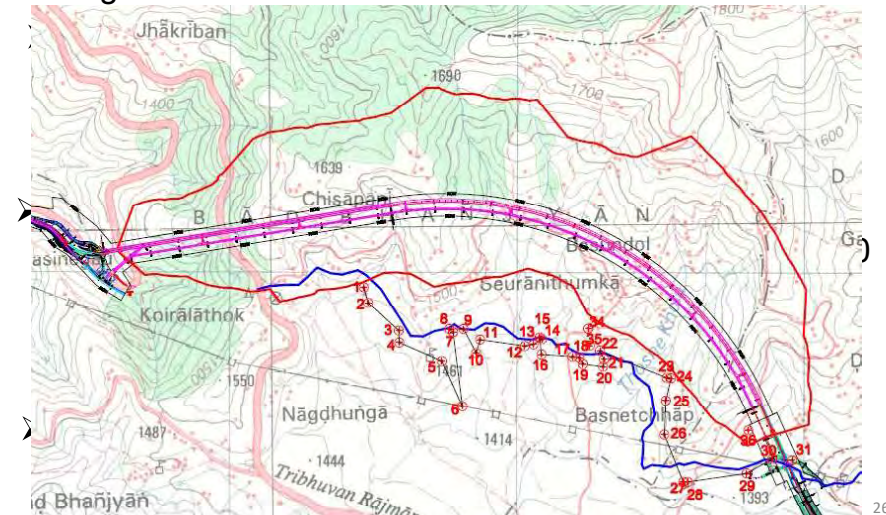

26

## 4.3. Tunnel Design

### Contents

- (1) Design Criteria of Mountain Tunnel
- (2) Classification and Support pattern
- (3) To ensure safety to users in case of emergency
- (4) Portal Detail Design
- (5) Drain, Pavement, other
- (6) Observation and Measurement during construction

27

## 4.3. Tunnel Design

### (1) Design Criteria of Mountain Tunnel

#### NATM Method outline

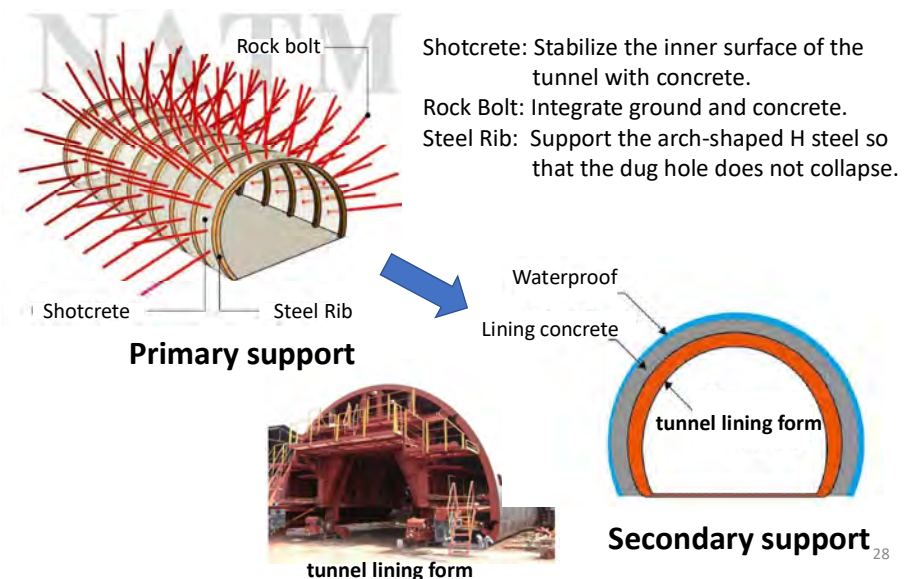

28

### 4.3. Tunnel Design

#### (1) Design Criteria of Mountain Tunnel

##### Excavation Method ( by blasting)

Excavation methods is changed according to the ground classification.

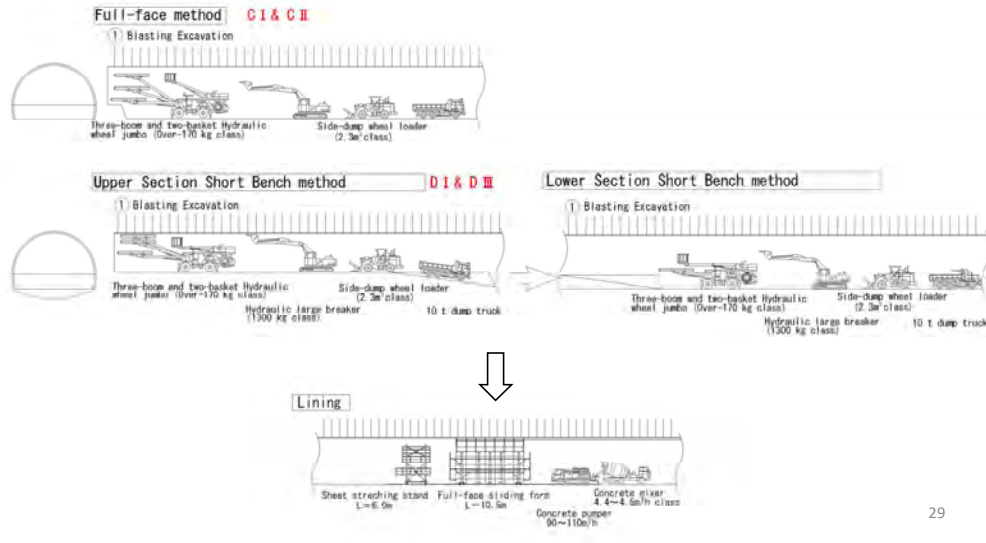

29

### 4.3. Tunnel Design

#### (2) Classification and Support pattern

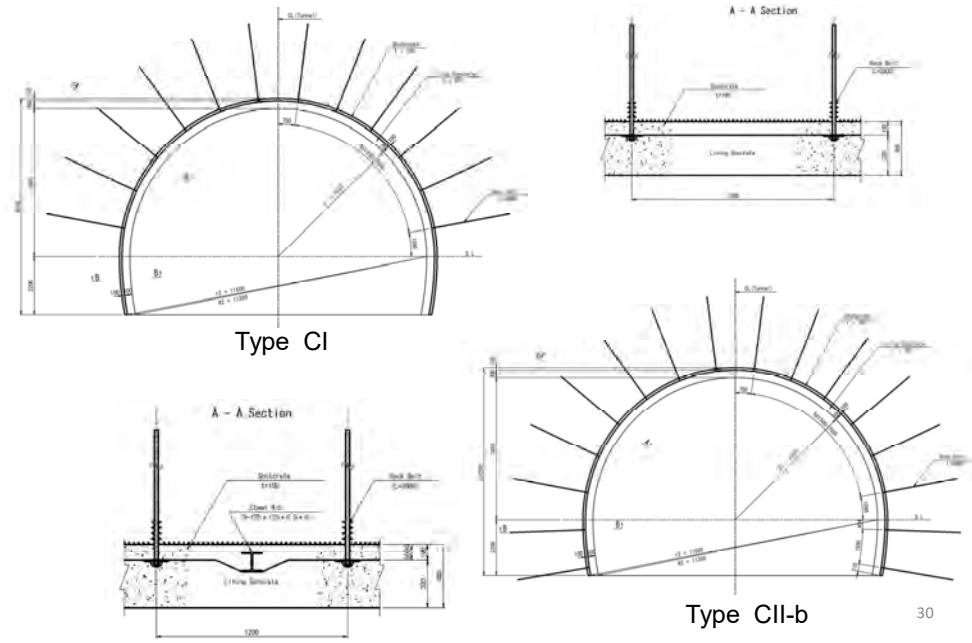

30

### 4.3. Tunnel Design

#### (3) To ensure safety to users in case of emergency

##### We proposed necessity of evacuation tunnel

- In Japan : Installation of escape routes on **A grade** follows **case by case** considerations of **length, traffic volume, design speed**
- In India : **Above 1,500m must have** an egress (2.0 × 2.5m) **isolated** from the main tunnel.
- In Euro : **Emergency exits are provided** where the traffic volume is higher than 2,000 vehicles per/lane/day.

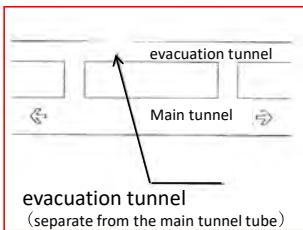

Taking India and Euro standard and Nepalese drivers' manner into consideration, we proposed to apply a separate evacuation tunnel.



31

### 4.3. Tunnel Design

#### (3) To ensure safety to users in case of emergency

Based on the Japanese guideline,

- **3 numbers of Emergency Parking Space on each lane will be install at 750m interval, and**
- **7 numbers of Evacuation Connecting Tunnel will be installed at about 375m interval.**

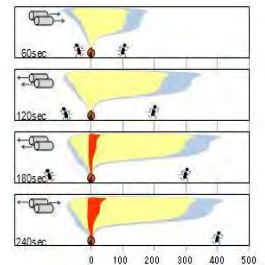

A simulation shows that with appropriate ventilation (Zero-flow control using inverter controlled Jet Fan), people can safely move a distance of 350~400 m.

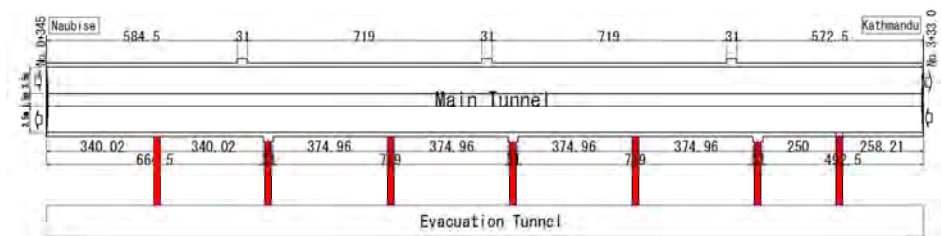

32

### 4.3. Tunnel Design

#### (3) To ensure safety to users in case of emergency

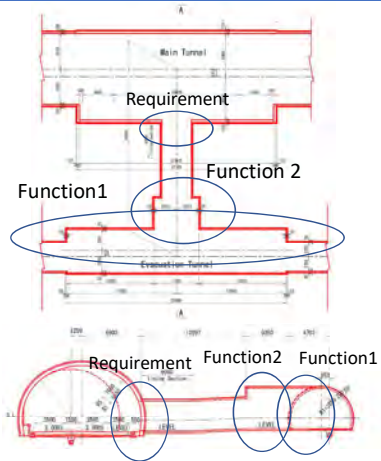

Function 1: Passing space during rescue operation and construction

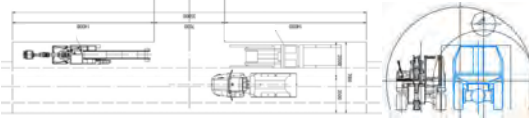

Function 2: Rotation place during rescue operation and construction

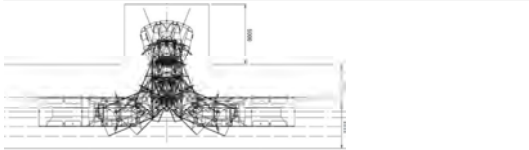

Requirement: Provision of doors between the two tunnels to prevent the inflow of smoke



### 4.3. Tunnel Design

#### (4) Portal Detail Design (East portal)

Splitted bamboo type portal harmonizing with the surrounding terrain will be adopted at east tunnel entrance (Exit).

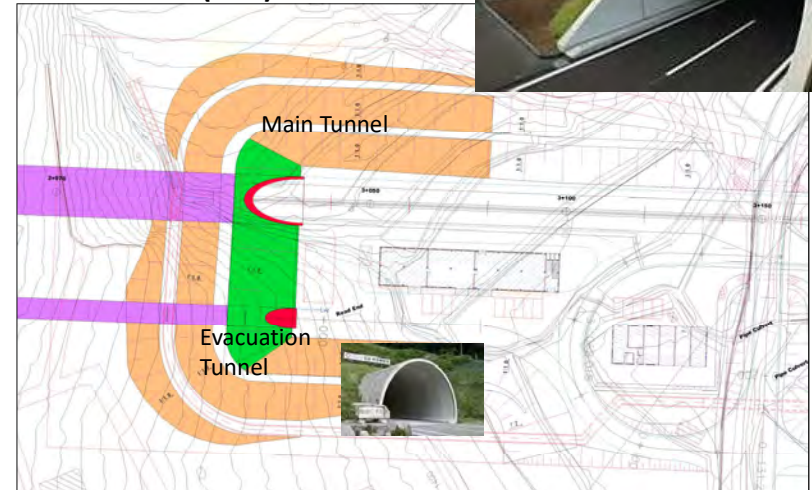

### 4.3. Tunnel Design

#### (4) Portal Detail Design (West portal)

Wall type portal will be adopted at west side entrance due to site condition (steep train).



### 4.3. Tunnel Design

#### (4) Portal Detail Design (West portal support pattern)

West Portal: Tunnel passes under the existing road with 6m overburden only. The auxiliary method support pattern will be designed after three-dimensional analysis.

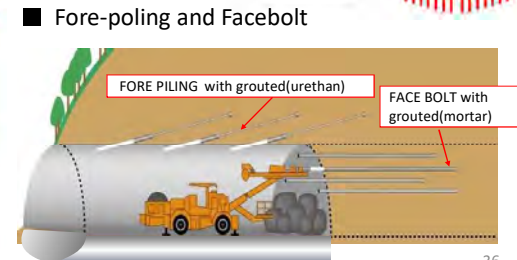
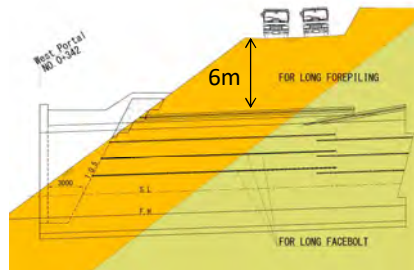
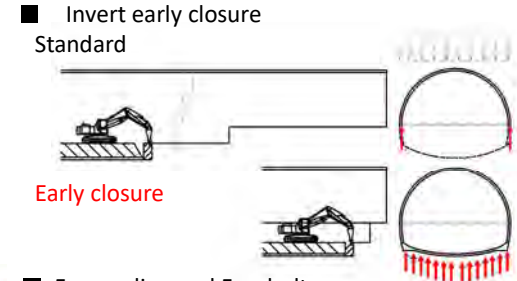



## 4.4. Tunnel Facility

### (1) About tunnel facility

⑦ Warning Board in Tunnel



⑧ Fire Hydrant & Extinguisher



⑨ Push button alarm



⑩ Emergency Phone



⑪ Emergency Exit



41

## 4.4. Tunnel Facility

### (3) Power supply, Water supply, Monitoring System

**Power supply systems will be installed at west and east portals.**

- East side, a transformer to convert the 11kV high voltage to low voltage will be installed.
- Up to west side, 11kV high voltage cable will be installed to supply power to Roadside service center.

**A power generation system to be used during power failure will be installed at east side. Water supply system considering water supply to affected houses**

- Water tank and pump system will be installed for fire fighting in tunnel.
- In addition, a separate water tank will be considered to distribute the spring water from the tunnel to the surrounding houses affected with ground water lowering.

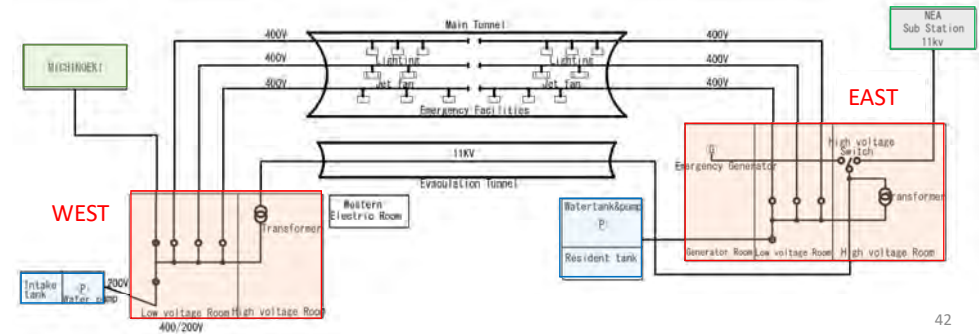

42

## 4.4. Tunnel Facility

### (3) Power supply, Water supply, Monitoring System

• **East Power and Water Supply**

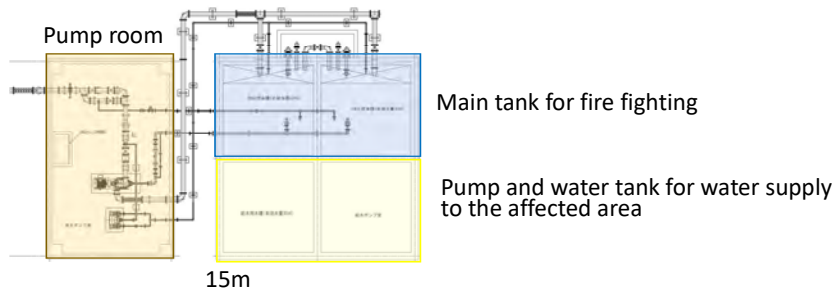
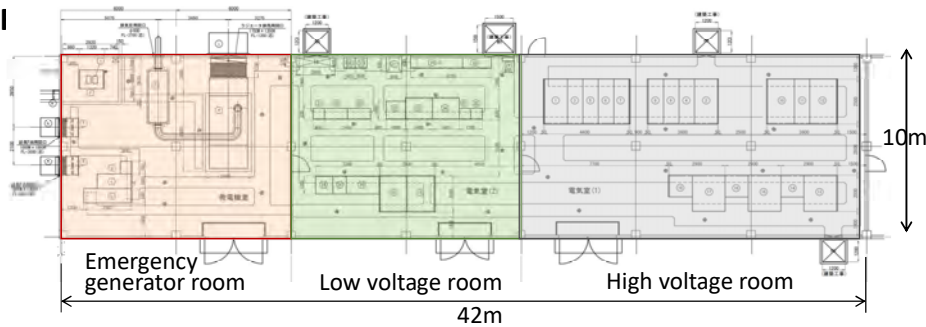

43

## 4.4. Tunnel Facility

### (3) Power supply, Water supply, Monitoring System

• **West Power and Water Supply**

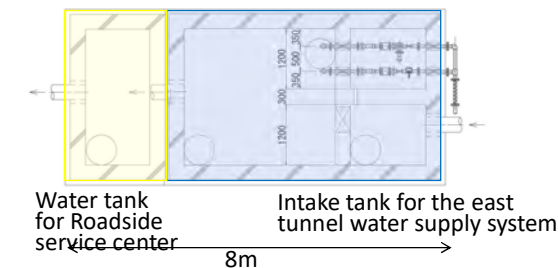
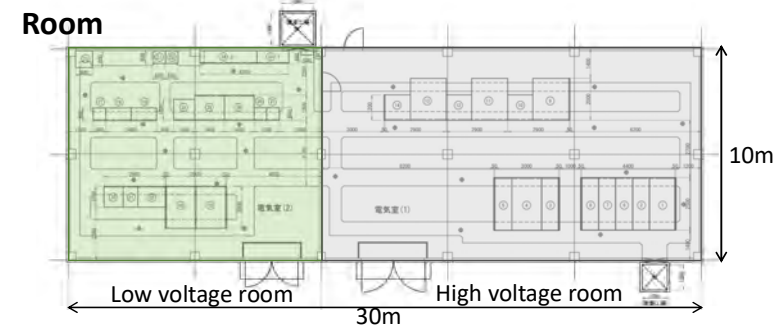

44

## 4.4. Tunnel Facility

### (3) Power supply, Water supply, Monitoring System

- Local tunnel **monitoring and control system** (DOR O&M team, Traffic police and Fire fighting team will stay in same facilities) will be adopted.
- Monitoring will be carried out in the **Central Monitoring Center by DOR**. Coordination among DOR Action Team, Traffic Police and Fire department will be conducted by **remote monitoring and control system**.

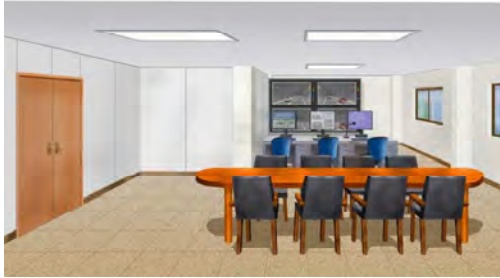

Traffic Monitor and Control Room

## 4.6 Construction

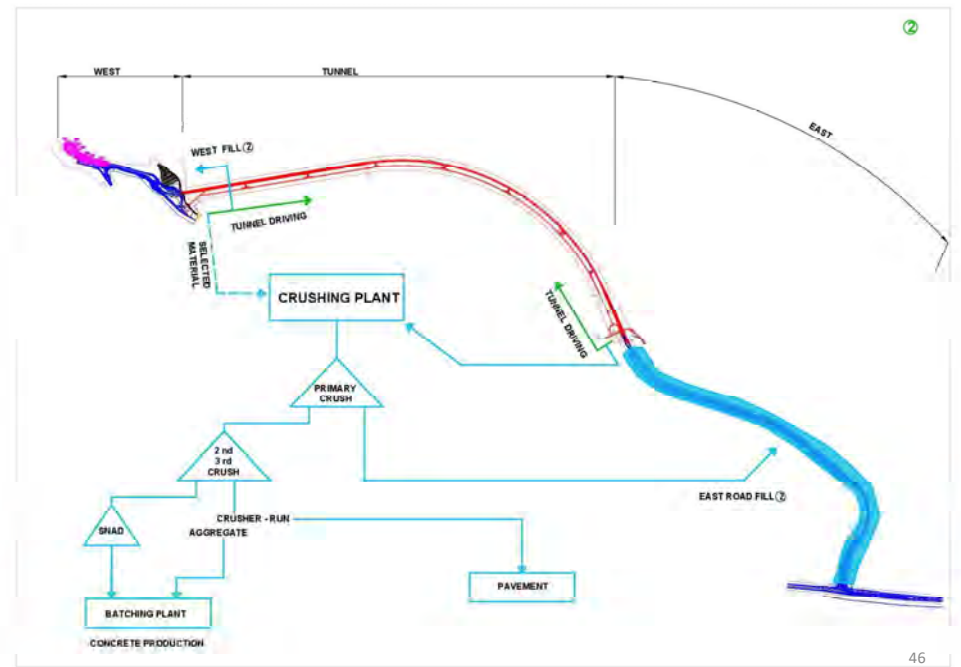

## 4.6 Construction

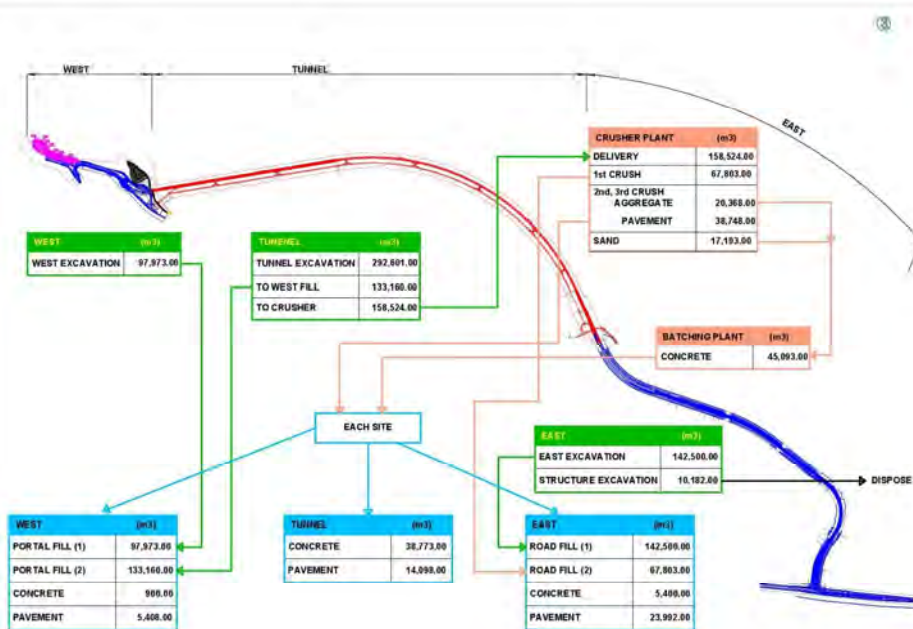

## 4.6 Construction

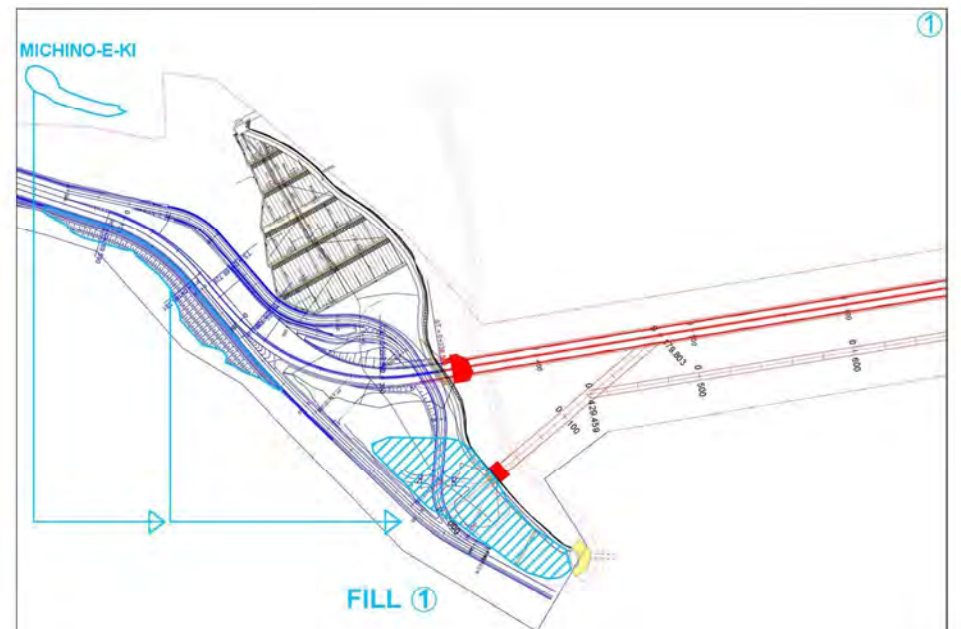

## 4.6 Construction

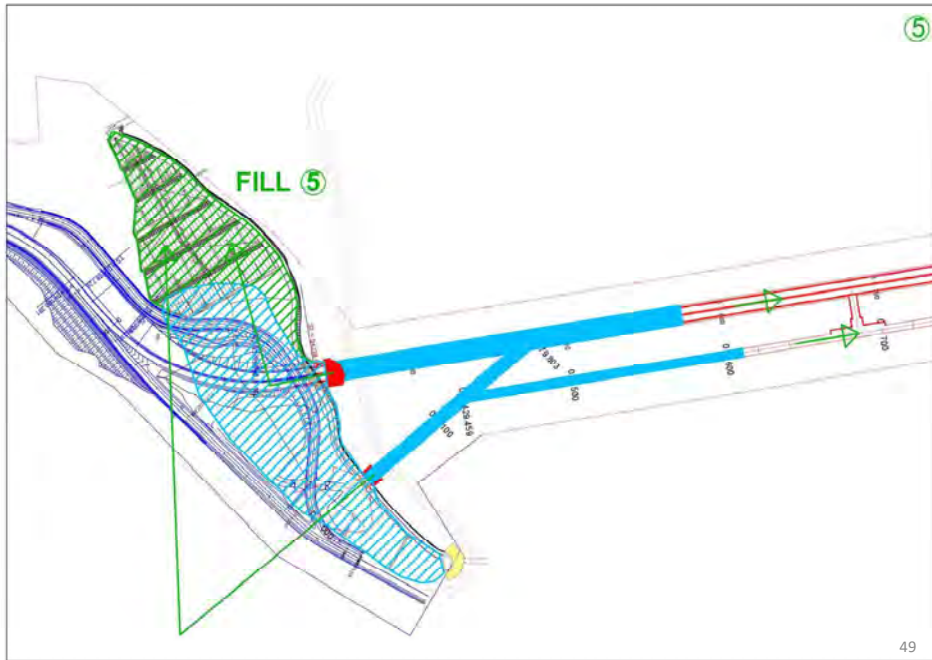

49

## 4.7 Operation & Maintenance (O&M) Plan for Nagdhunga Tunnel

1. 24 hours Lighting and Ventilation
2. 24 hours Watching and Waiting for Accident inside Tunnel
3. 24 hours Toll Collection
4. Immediate Backup for Power-cut
5. Continuous/Preventive Maintenance to avoid Closure of Tunnel

**Nagdhunga Tunnel has to be operated and maintained with concrete organization and O&M plan.**

50

## Overall O&M Organization

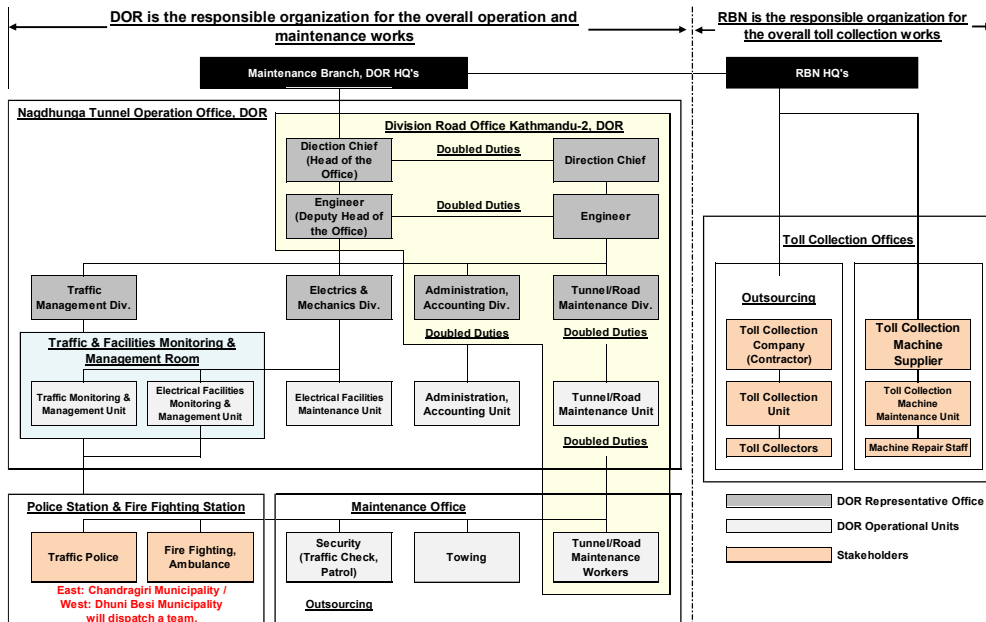

51

## Personnel and Staffing Plan for O&M Works

No.	Division/Unit	Responsible Organization	Number of Staff		
			Management Position	Staff	Total
(1)	Management	DOR	2	0	2
(2)	Administration	DOR	1	2	3
(3)	Traffic/Facilities Monitoring and Management (3 sif)	DOR	3	12	15
(4)	Equipment Maintenance	DOR	1	6	7
(5)	Security (Patrolling) (3 sif)	DOR	2	12	14
(6)	Towing (3 sif)	DOR	—	6	6
(7)	Tunnel/Road Maintenance	DOR	1	6	7
<b>Total Number of Staff by DOR</b>			<b>10</b>	<b>44</b>	<b>54</b>
(8)	Traffic Police (3 sif)	Police	1	12	13
(9)	Ambulance (3 sif)	Hospital	1	9	10
(10)	Fire Fighting (3 sif)	Fire Station	1	12	13
<b>Total Number of Staff by Stakeholders</b>			<b>3</b>	<b>33</b>	<b>36</b>
<b>Total Number of Staff</b>			<b>13</b>	<b>77</b>	<b>90</b>

52

# Rescue Office

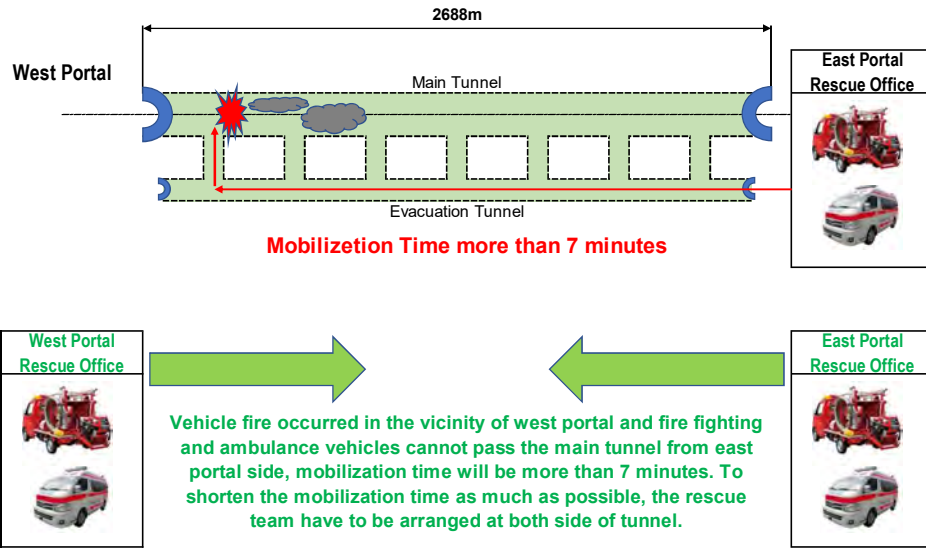

# Location of O&M Buildings

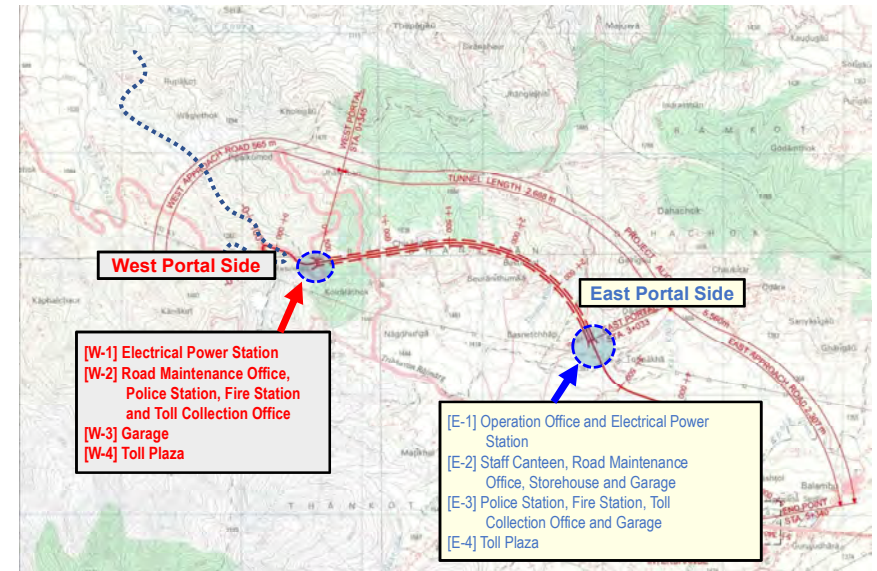

# O&M Buildings Layout Plan at East Portal Side

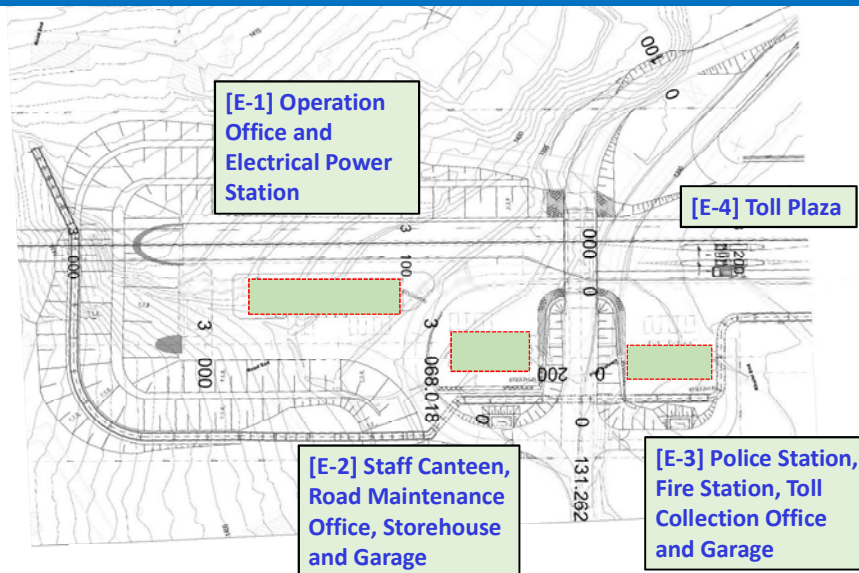

# O&M Buildings Layout Plan at West Portal Side

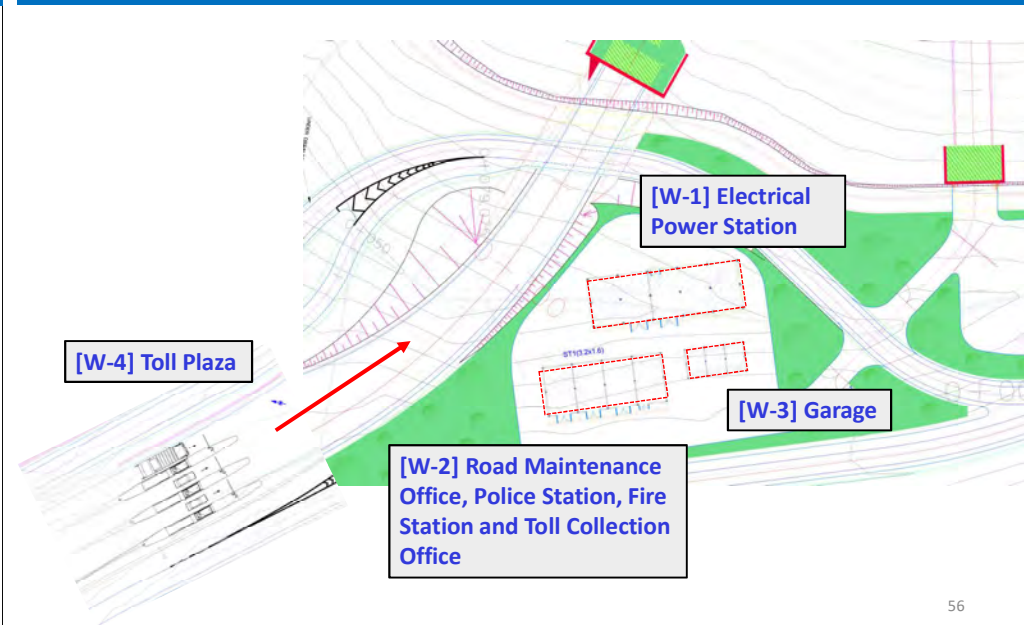

# Layout Plan of DOR O&M Office

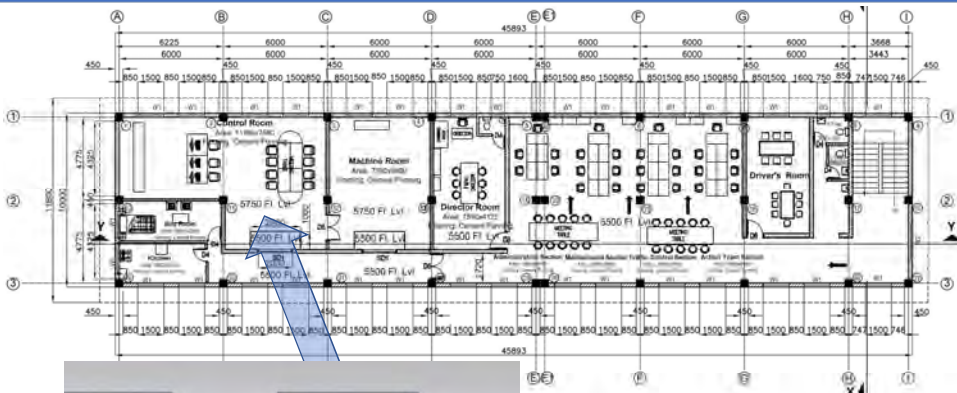

Control Room

# DISASTER PREVENTION SCENARIO AT CONTROL ROOM (CASE: Fire)

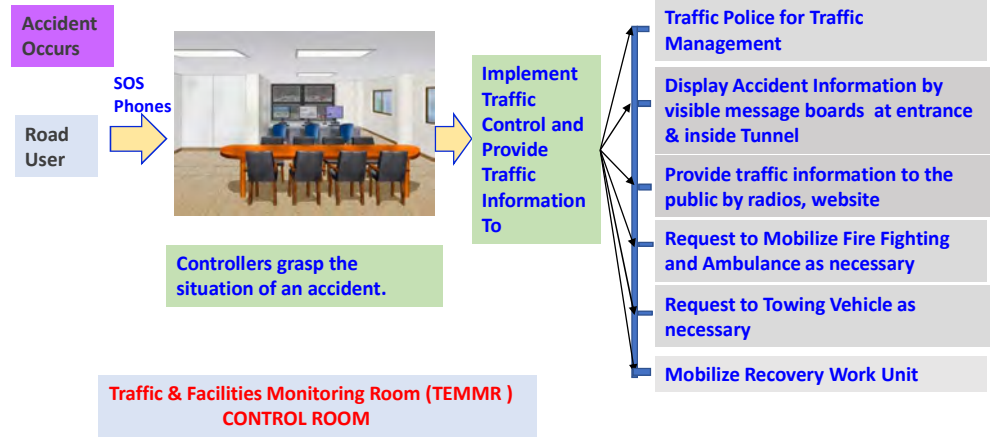

# Major Equipment

## Transportation, Maintenance, Traffic Management Works

			
Pick up truck 2 nos.	Truck (3t) Mounted Scissor Lift 1 nos.	Truck Mounted Movable Sign-Board 3 nos.	

## Rescue Works (Fire Fighting, Ambulance, Towing)

			
Small Type Fire Engine 2 nos.	Ambulance 2 nos.	Towing Vehicle (40 Ton Rotator Tow Truck ) 1 nos.	Towing Vehicle (2 winch 8ton) 1 nos.

# Toll Plaza

- Road Board of Nepal (RBN) is the responsible organization for the entire toll collection works in Nepal.
- Therefore, RBN is expected to install toll collection equipment.
- However, because of the first installment in Nepal, toll collection equipment will be installed in the Project.
- After toll collection equipment is introduced, through operation, maintenance and repair of the equipment RBN should have a capacity of operation, maintenance and procurement of the toll collection system in future.
- In addition, if the toll collection equipment will be installed, it is required to make the time to train the toll collectors before opening to the traffic of Nagdhunga Tunnel.

# What kind of toll collection equipment will be installed?

- Minimization of waiting time at tollbooths and prevention of fraud by toll collectors who conduct toll collection works can be expected by introducing toll collection equipment.
- Semi-automatic machine is preferred by RBN, and toll collection equipment shall have the function, such as count the number of vehicles, identify the type of vehicles, issue receipts etc., to achieve those objectives.



Automatic Vehicle Identification

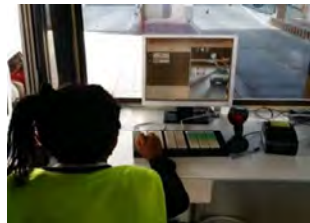

Toll Collection Technology



Lane Technology

61

# O&M Capacity Development

The Project includes O&M Capacity Development Program in the last stage of construction to initial stage of the operation.

No.	Work Item	2017				2018				2019				2020				2021				2022				2023			
		Q1	Q2	Q3	Q4	Q1	Q2	Q3	Q4	Q1	Q2	Q3	Q4	Q1	Q2	Q3	Q4	Q1	Q2	Q3	Q4	Q1	Q2	Q3	Q4	Q1	Q2	Q3	Q4
<b>Design &amp; Procurement Stage</b>																													
1	Detailed Design	[Orange]				[Light Blue]																							
2	Procurement of Works					[Light Blue]																							
<b>Construction &amp; Capacity Development Stage</b>																													
3	Construction									[Green]				[Green]				[Green]											
4	Capacity Development																	[Blue]				[Blue]							
<b>O&amp;M Preparing and Implementing Stage</b>																													
4-1	Preparing the O&M Plan																	[Blue]											
4-2	Developing the Tunnel O&M Manuals													[Blue]				[Blue]											
4-3	Planning the O&M Training													[Blue]				[Blue]											
4-4	Set up the new O&M Organization													[Blue]				[Blue]											
4-5	Implementing the training													[Blue]				[Blue]				[Blue]							
4-6	Implementing the On-the-Job training													[Blue]				[Blue]				[Blue]							
4-7	Evaluating and Reporting the O&M Training Results																					[Blue]							

62

# Status of Land Acquisition OCT 2019

## Status of Land Acquisition

Description	No of owners		Total land parcels		Area of acquired land (paid)				Payment (NRs in million)	
	This Period	Cumulative	This Period	Cumulative	Area (Sq m)	Cum Area Sqm	Area (Ropani)	Cum Area (Ropani)	Payment	Cum. Payment
<b>1. Land Compensation</b>										
Fiscal year 2017-18	63	63	77	77	17,555.90	17,555.90	34-8-0-2.24	34-8-0-2.24	702.72	702.72
Fiscal year 2018-19.	200	263	258	335	82,394.19	99,950.09	161-15-1-1.33	196-7-2-0.12	4,278.06	4,980.78
FY 2019-20 AUG	0	263	0	335	-	99,950.09	0	196-7-2-0.12	4,980.78	4,980.78
FY 2019-20 SEP	12	275	10	345	3,278.97	103,229.06	6-7-0-2	202-14-2-2.12	133.85	5,114.63
FY 2019-20 OCT										
Total Update as of OCT 2019		275		345		103,229.06		202-14-2-2.12		5,114.63

## 2. House & Structure Compensation

Kathmandu Side as of End of July 2019( 2018-2019) 43.25

Description	Total		Progress Made up to this month(sept,2019)		
	Unit	Qty/ Amount	Qty/ Amount	% progress	Remarks
Payment for Land	Mil. NPR	5,610.00	5,114.63	91.17%	
Acquired Land (No. of Plots)	No	437.00	345	78.95%	

63

# Status of Land Acquisition OCT 2019

Description	Details of Land Parcels													
	East Portal and Approach Road							West Portal and Approach Road						
	Total No Owners.	Land Parcels	Ropani				Sq m	Total No Owners.	Land Parcels	Ropani				Sq m
		R	A	P	D				R	A	P	D		
Private	292	382	233	15	3	2.2	108,487.00	11	14	13	5	0	3.91	6,780.34
Guthi ( Private)		4	3	4	0	2.82	1,659.00		7	28	9	0	3.18	14,537.12
Guthi (Govt.))									6	10	8	1	2.06	5,353.79
Non Registered		51	25	10	3	3.4	13,067.00		6	6	0	3	1.62	3,079.48
Government		41	32	6	3	0.39	12,325.00		1	0	8	0	3.00	260.34
Within 25m ROW									18	50	13	0	1.35	25,842.88
Sub Total	292	478	266	6	2	2.59	135,539.00	11	52	109	12	2	2.09	55,853.95
<b>Total lan parcels to be acquired for NTCP East &amp; West</b>								<b>303</b>	<b>530</b>	<b>376</b>	<b>3</b>	<b>1</b>	<b>0.68</b>	<b>191,392.95</b>
Total compensation Payment made to the OCT 2019								<b>275</b>	<b>345</b>	<b>202</b>	<b>14</b>	<b>2</b>	<b>2.12</b>	<b>103,229.06</b>

## Progress payment w.r.t land area .

Description	Total Area (Sq m)	Progress%	Remarks
Total land acquired in East & west	191,392.95	53.94	
Total Land to be acquired (East)	135,539.00	76.16	
Total Private land	115,267.34	89.56	
Total Private land (East)	108,487.00	95.15	

64

# Contract Activities

- Tender Notice Publication August 10, 2018
- Opening of Tender October 25, 2018
- Submission of Tech. Bid Evaluation Rep (Draft) January 4, 2019
- Submission of Tech. Bid Evaluation Rep March 12, 2019
- Financial Bid Opening March 25, 2019
- Clarification Process March 25 - May 31, 2019
- Submission of Final Bid Evaluation June 14, 2019
- Draft Contract Signed August 5, 2019
- Contract Negotiation Aug 9 – Sept 23, 2019
- Signing of Contract Sept 23, 2019
- Commencement of Works Nov 14, 2019

65

# Construction Supervision

## Tunnel Face Observation Sheet

Nagdhunga Tunnel Construction Project  
Tunnel Face Observation sheet

Geological Documentation of Tunnel Face  
(Developing Tunnel Plan)

Geological Description:  
Medium to dark grey phyllite interstratified with light grey calcareous sandstone. Phyllite is dominant on the face. Rock at left side is broken by striking each other and highly to moderately weathered, whereas rocks at crown and right side is easily broken by hand and highly weathered. The spacing of discontinuities along the foliation plane (80°-91°) varies between 7 cm and 13 cm. The joints are along the plane (38°/77°) has the spacing 8, 30 cm, and joint 2 set with the attitude of 38°/80° has spacing between 5 cm and 30 cm, aperture along foliation plane is 10 mm. The opening of joint 1 is between 1 m and 5 m, whereas joint 2 has 45 cm opening. The openings of all the discontinuities are filled with clay and sil. The surface of foliation are siliceous, whereas joint 1 and joint 2 have smooth surface. Thickness of clay bands varies from 0.5 to 1 cm. Effect of discontinuities to the tunnel is very favorable. Risk is in quite condition.

Prepared by	Checked by	Received by	Reviewed by	Acknowledged by
By	By	Area	Resident Eng.	By
[Signature]	[Signature]	[Signature]	[Signature]	[Signature]

Prepared by: [Name], Checked by: [Name], Received by: [Name], Reviewed by: [Name], Acknowledged by: [Name]

Date: [Date]

Scale: [Scale]

Project Name: Nagdhunga Tunnel Construction Project

Sheet No: [Number]

Scale: [Scale]

Project Name: Nagdhunga Tunnel Construction Project

Sheet No: [Number]

Scale: [Scale]

## 4.3. Tunnel Design (5) Drain, Pavement, other

**Drain :** Round shape side drain will be adopted. Sub-surface drain separated from road surface drain will be installed.

**Inspection passage :** To store a lot of electric cables and a water pipe, left hand side passage will be raised.

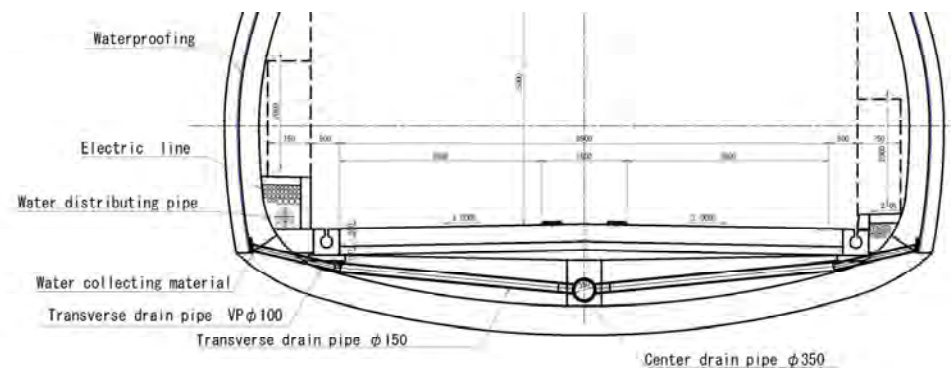

68

### 4.3. Tunnel Design

#### (2) Classification and Support pattern

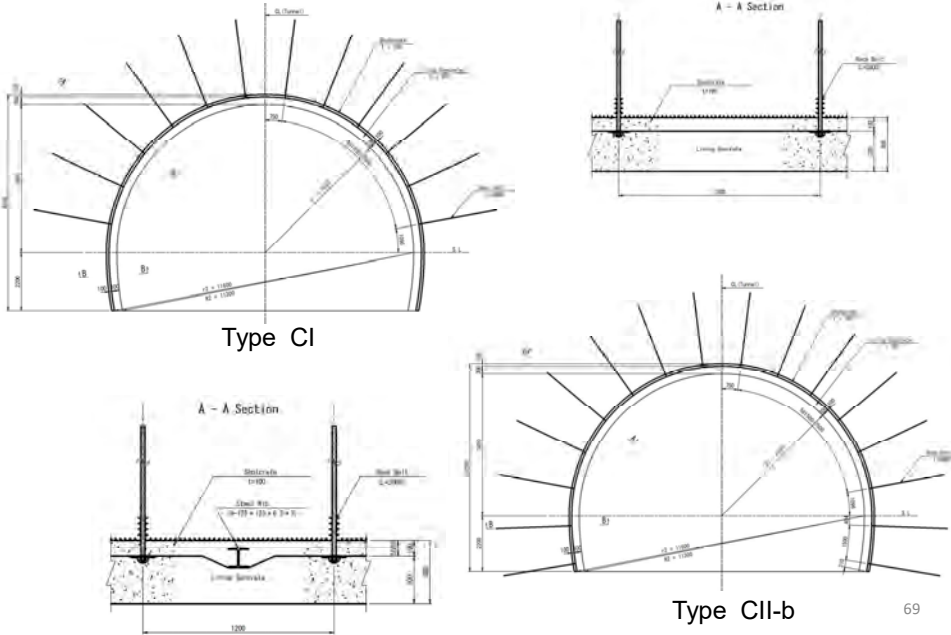

69

### Monitoring – Divergence, Convergences Face, Benching (Lower Section), and Invert

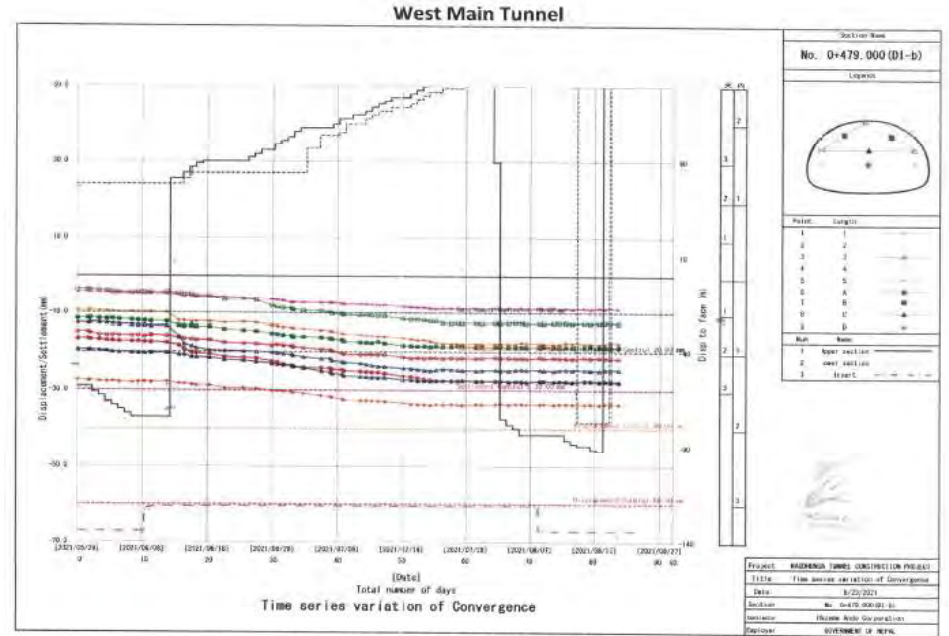

### Monitoring – Divergence, Convergences Face, Benching (Lower Section), and Invert

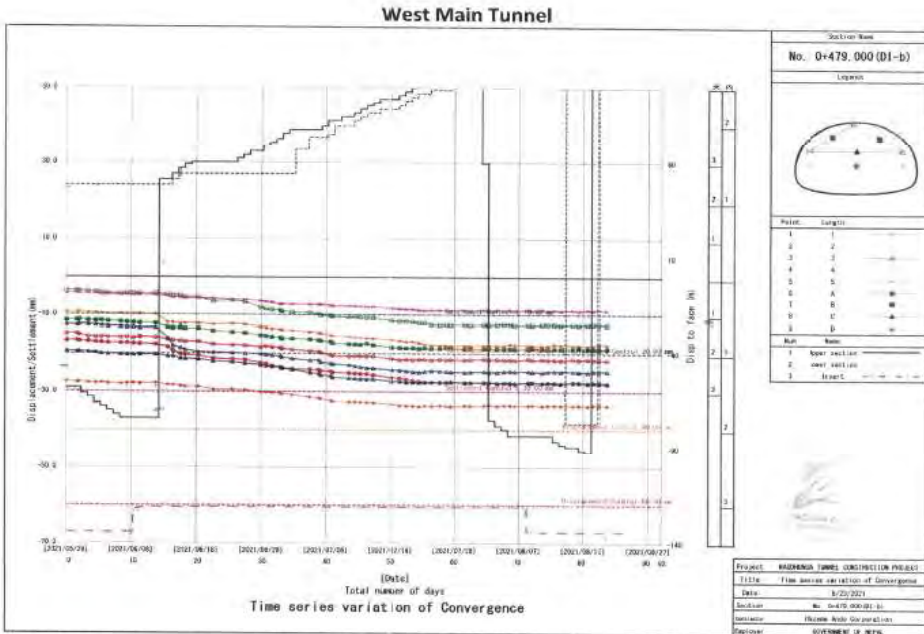

### Displacement Measurement. Crown Settlement Data

Displacement measurement / crown settlement data sheet

Site name:	Hadramawt Tunnel Construction Project
Crown No:	17 (Main Tunnel)
Station:	No. 0+382.0
Support pattern:	53330
Clearance/height:	6.97m

No	Date	Days elapsed	Distances to the face		Displacement amount				Chair Settlement
			up half	lower	A	B	C	D	
1	2021/10/09	2	2.52	-3.10	0.0	0.0	0.0	0.0	0.0
2	2021/10/10	3	3.40	-2.16	1.2	0.3	-3.3	-5.8	-5.8
3	2021/10/11	4	4.30	-2.10	1.1	-0.1	-6.6	-14.1	-14.1
4	2021/10/12	5	5.20	-2.26	4.3	-3.8	-8.1	-21.0	-21.0
5	2021/10/24	17	6.10	2.66	1.2	-5.2	-11.4	0.0	-25.8
6	2021/10/25	18	8.00	4.10	0.1	-6.3	-12.8	-1.8	-28.4
7	2021/10/26	20	6.05	4.10	0.3	-5.5	-12.9	-1.7	-31.9
8	2021/10/27	22	6.00	5.00	0.2	-5.6	-13.3	-2.3	-34.4
9	2021/10/28	25	-8.00	6.10	0.4	-6.3	-13.1	-3.3	-36.6
10	2021/10/29	26	15.00	6.10	0.2	-6.5	-12.8	-4.2	-36.7
11	2021/11/02	34	16.00	6.10	1.1	-5.7	-12.0	-5.7	-35.8
12	2021/11/03	35	15.00	5.10	1.1	-6.3	-13.3	-6.5	-38.0
13	2021/11/04	37	15.00	5.10	1.1	-6.3	-13.3	-6.5	-38.0
14	2021/11/05	38	15.00	5.10	1.1	-6.3	-13.3	-6.5	-38.0
15	2021/11/06	39	15.00	5.10	1.1	-6.3	-13.3	-6.5	-38.0
16	2021/11/07	40	15.00	5.10	1.1	-6.3	-13.3	-6.5	-38.0
17	2021/11/08	41	15.00	5.10	1.1	-6.3	-13.3	-6.5	-38.0
18	2021/11/09	42	15.00	5.10	1.1	-6.3	-13.3	-6.5	-38.0
19	2021/11/10	43	15.00	5.10	1.1	-6.3	-13.3	-6.5	-38.0
20	2021/11/11	44	15.00	5.10	1.1	-6.3	-13.3	-6.5	-38.0
21	2021/11/12	45	15.00	5.10	1.1	-6.3	-13.3	-6.5	-38.0
22	2021/11/13	46	15.00	5.10	1.1	-6.3	-13.3	-6.5	-38.0
23	2021/11/14	47	15.00	5.10	1.1	-6.3	-13.3	-6.5	-38.0
24	2021/11/15	48	15.00	5.10	1.1	-6.3	-13.3	-6.5	-38.0
25	2021/11/16	49	15.00	5.10	1.1	-6.3	-13.3	-6.5	-38.0
26	2021/11/17	50	15.00	5.10	1.1	-6.3	-13.3	-6.5	-38.0
27	2021/11/18	51	15.00	5.10	1.1	-6.3	-13.3	-6.5	-38.0
28	2021/11/19	52	15.00	5.10	1.1	-6.3	-13.3	-6.5	-38.0
29	2021/11/20	53	15.00	5.10	1.1	-6.3	-13.3	-6.5	-38.0
30	2021/11/21	54	15.00	5.10	1.1	-6.3	-13.3	-6.5	-38.0
31	2021/11/22	55	15.00	5.10	1.1	-6.3	-13.3	-6.5	-38.0
32	2021/11/23	56	15.00	5.10	1.1	-6.3	-13.3	-6.5	-38.0
33	2021/11/24	57	15.00	5.10	1.1	-6.3	-13.3	-6.5	-38.0
34	2021/11/25	58	15.00	5.10	1.1	-6.3	-13.3	-6.5	-38.0
35	2021/11/26	59	15.00	5.10	1.1	-6.3	-13.3	-6.5	-38.0
36	2021/11/27	60	15.00	5.10	1.1	-6.3	-13.3	-6.5	-38.0
37	2021/11/28	61	15.00	5.10	1.1	-6.3	-13.3	-6.5	-38.0
38	2021/11/29	62	15.00	5.10	1.1	-6.3	-13.3	-6.5	-38.0
39	2021/11/30	63	15.00	5.10	1.1	-6.3	-13.3	-6.5	-38.0
40	2021/12/01	64	15.00	5.10	1.1	-6.3	-13.3	-6.5	-38.0
41	2021/12/02	65	15.00	5.10	1.1	-6.3	-13.3	-6.5	-38.0
42	2021/12/03	66	15.00	5.10	1.1	-6.3	-13.3	-6.5	-38.0
43	2021/12/04	67	15.00	5.10	1.1	-6.3	-13.3	-6.5	-38.0
44	2021/12/05	68	15.00	5.10	1.1	-6.3	-13.3	-6.5	-38.0
45	2021/12/06	69	15.00	5.10	1.1	-6.3	-13.3	-6.5	-38.0
46	2021/12/07	70	15.00	5.10	1.1	-6.3	-13.3	-6.5	-38.0
47	2021/12/08	71	15.00	5.10	1.1	-6.3	-13.3	-6.5	-38.0
48	2021/12/09	72	15.00	5.10	1.1	-6.3	-13.3	-6.5	-38.0
49	2021/12/10	73	15.00	5.10	1.1	-6.3	-13.3	-6.5	-38.0
50	2021/12/11	74	15.00	5.10	1.1	-6.3	-13.3	-6.5	-38.0

## Displacement Measurement. Crown Settlement Data

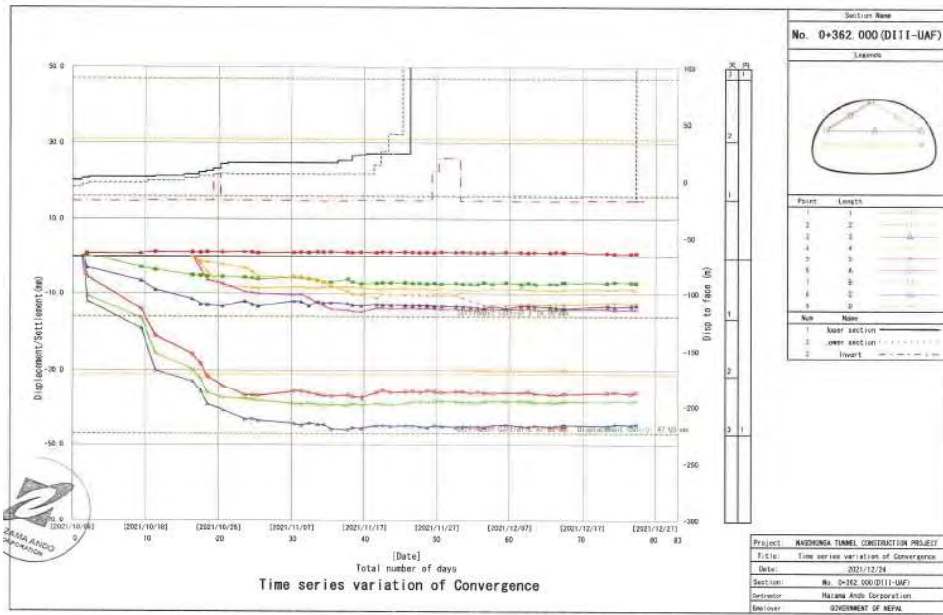

## PHOTOGRAPHS

### Photos of Some Construction Activities



Excavation work completed up to Sta. 2+928.00 in Main Tunnel (East Side)



Water Proofing Works at East Main Tunnel



Movable Scaffolding for Water Proofing inside Tunnel Works (East)



Movable Form Work for Lining



East Portal (Kathmandu Side)



West Portal (Dhading Side)



Toolbox Meeting (Every Morning)



Progress Status

STATUS - TUNNEL EXCAVATION		Date: as of January 6, 2022					
S N	Tunnel	Total (m)	Update Status, m (approx)				
			From East		From West		Total
1	Main Tunnel	2,688	379.40 (14.1%)	370.00 (13.8%)	749.40 (27.9%)		
2	Evacuation Tunnel	2,557	752.50 (29.4%)	530.50 (20.7%)	1,283.00 (50.2%)		
3	Working Adit	126		126.00 (100%)	126.00 (100.0%)		
4	Cross Passage	128	27.85 (21.8%)	15.55 (12.1%)	43.40 (33.9%)		
	<b>Total</b>	<b>5,499</b>	<b>1,159.75 (21.1%)</b>	<b>1,042.05 (18.9%)</b>	<b>2,201.80 (40.0%)</b>		

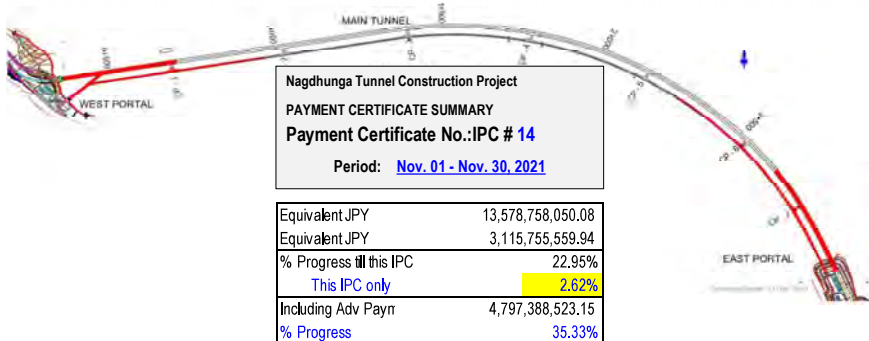

Thank You

**THE PROJECT FOR  
THE OPERATION AND MAINTENANCE  
OF  
THE SINDHULI ROAD PHASE 2**

**CONSTRUCTION OF THREE BRIDGES  
(GHYAMPE, MAMTI AND BHYAKURE)  
LOCATED BETWEEN CH. 111+400 TO CH. 119+700  
OF BP HIGHWAY**

**DESIGN REPORT  
FOR  
THE PILOT PROJECT**

**OCTOBER 2020**

**JICA EXPERT TEAM**



## Table of Contents

<b>1</b>	<b>PILOT PROJECTS FOR RESTORATION OF DAMAGED CAUSEWAYS OF THE SINDHULI ROAD.....</b>	<b>1</b>
1.1	INTRODUCTION.....	1
1.1.1	Background .....	1
1.1.2	Overall Goal, Project Purpose and Outputs of the Project .....	1
1.1.3	Plan of Operation .....	1
1.1.4	Implementation Structures .....	2
<b>2</b>	<b>SELECTION OF THE SITES FOR PILOT PROJECT .....</b>	<b>3</b>
2.1	SINDHULI ROAD PROJECT .....	3
2.1.1	Present Condition .....	3
2.1.2	Traffic Increase.....	4
2.1.3	Restoration of Causeways .....	5
2.1.4	Evaluation of the Damaged Causeway for Restoration .....	6
<b>3</b>	<b>NATURAL CONDITION SURVEY INCLUDING EIA, TOPOGRAPHY, GEOTECHNICAL INVESTIGATIONS .....</b>	<b>9</b>
3.1	NATURAL CONDITION SURVEY WORKS .....	9
3.2	ENVIRONMENT IMPACT ASSESSMENT (EIA) AND/OR INITIAL ENVIRONMENT EXAMINATION (IEE) SURVEY .....	9
3.3	TOPOGRAPHICAL SURVEY .....	9
3.4	GEOTECHNICAL SURVEY .....	10
3.4.1	Geotechnical Survey based on type of Foundation .....	10
3.4.2	Geotechnical Survey of the Work.....	10
3.4.3	Scope of the Work .....	11
3.4.4	Expected Output of Geotechnical Investigation.....	11
3.4.5	Correction of the SPT Values .....	11
3.4.6	Determination of Permissible Bearing Capacity for Open Foundation.....	11
3.4.7	Estimation of Coefficient of sub-grade reaction for Raft Foundation.....	12
3.5	FIELD INVESTIGATION .....	14
<b>4</b>	<b>HYDROLOGICAL ANALYSIS FOR BRIDGE WATERWAY .....</b>	<b>16</b>
4.1	RETURN PERIOD OF RAINFALL FOR ESTIMATION OF PEAK FLOOD DISCHARGE.....	16
4.2	ESTIMATION OF RAINFALL INTENSITY FOR TIME OF CONCENTRATION DURATION .....	16
4.3	FREQUENCY ANALYSIS OF ANNUAL MAXIMUM DAILY RAINFALL .....	17
4.4	ISOHYETS OF DESIGN DAILY RAINFALLS OF THE PROJECT AREA.....	18
4.5	FREQUENCY ANALYSIS OF SHORT DURATION RAINFALL .....	20
4.6	ESTIMATION OF PEAK FLOOD DISCHARGE IN THE TRIBUTARIES .....	21
4.6.1	Catchment Area of Tributaries .....	21
4.6.2	Estimation of Time of Concentration Flow .....	22
(1)	Travel Time of Overland Flow ( $T_1$ ).....	22
(2)	Travel Time of Flow in Channel ( $T_2$ ) .....	23
(3)	Time of Concentration.....	24
4.6.3	Estimation of Rainfall Intensity for Time of Concentration Duration .....	24
4.6.4	Determining Peak Flood Discharge.....	25
4.6.5	Corollary, Calculation of Discharge by Broad Crested Method.....	26
(1)	Verification of the Bhyakure Tributary on the 12 <sup>th</sup> July 2019 Flood.....	26
<b>5</b>	<b>HYDRAULICS STUDY FOR BRIDGE DESIGN .....</b>	<b>29</b>
5.1	ESTIMATION OF PEAK FLOOD DISCHARGE IN THE TRIBUTARIES .....	29
5.1.1	Hydraulics Analyses .....	29
5.2	DEBRIS FLOW PHENOMENON.....	29
5.3	CONSIDERATION OF PIER CONSTRUCTION IN DEBRIS FLOW WITH BOULDERS .....	31
5.4	ESTIMATION OF PEAK FLOOD DISCHARGE OF DEBRIS FLOW .....	32
5.4.1	At Debris Flow Passing Section .....	32
5.4.2	At Debris Flow Stopping and Sediment Flow Passing Section.....	32
5.4.3	At Sediment-Flow Section .....	33
5.5	ANALYSIS OF THE FLOOD FLOW IN TRIBUTARIES .....	34
5.5.1	Open Channel Flood Flow Analysis.....	34
5.5.2	The Liner Waterway at HFL for each Tributary .....	34
5.5.3	Manning's Rugosity Coefficient.....	34

5.5.4	Channelized Waterway .....	35
5.5.5	Analysis of the Flood Flow in Tributaries.....	36
5.6	DETERMINATION OF LENGTH OF THE BRIDGES .....	37
5.6.1	General Considerations .....	37
5.6.2	Waterway in a Hilly or Mountainous Terrain .....	38
5.6.3	Verification of the Past Experience .....	39
5.6.4	Verification of the Social Impact by the Scale of the Bridges construct in Dense Area .....	42
5.6.5	Conclusion of Selection of the Bridge Size.....	44
5.7	VERTICAL CLEARANCE OF THE BRIDGE.....	45
5.7.1	Design Policy .....	45
5.7.2	Vertical Clearance .....	45
5.7.3	Determination of Maximum Wave Height of Debris-Flow .....	47
(1)	Characteristics of the Rivers where Damaged Causeways are located .....	47
5.7.4	Criteria for Fixing the Vertical Clearance of the Bridge .....	47
(1)	Flow Water Depth (Clearance for Flow) ( $H_{DF}$ , $H_{FF}$ ).....	47
(2)	Height of Flow Water Depth ( $H_{DF}$ and $H_{FF}$ ) .....	48
(3)	Sediment Deposit Depth ( $H_{SD}$ ).....	48
(4)	Debris Clearance ( $H_{DC}$ ) .....	48
(5)	Free Board for Bridge ( $H_{FB}$ ).....	49
5.7.5	Determination of Vertical Clearance .....	49
(1)	The Linear Waterway at HFL corresponding to Design Flood Discharge (Case-1 & 2).....	50
(2)	Specific Energy Head (Case-3) .....	51
(3)	Determination of the Vertical Clearance Height.....	51
5.8	DETERMINATION OF SCOUR DEPTH .....	52
5.8.1	Selection of size of bed materials, approach and findings .....	52
5.8.2	Equations for Scour Depth Estimation .....	53
(1)	Case-1 Scour Depth Calculation by Clause 703 of IRC:78-2014 .....	54
(2)	Case-2 Scour Depth Calculation by Farraday and Charlton Equation .....	55
(3)	Case-3 Scour Depth Calculation by Blench Equation .....	56
5.8.3	Adoption of Scour Depth.....	57
5.8.4	Determination of the Bridge Structure Dimensions .....	57
<b>6</b>	<b>CONCEPTIONAL DESIGN OF BRIDGE FOR RESTORATION OF CAUSEWAY (ALTERNATIVES) .....</b>	<b>59</b>
6.1	CONCEPTIONAL DESIGN OF BRIDGE .....	59
6.2	CONCLUSIONS .....	63
6.2.1	Conclusion based on Hydrological, Hydraulics, Social and Financial Condition.....	63
6.2.2	Conclusion on Selection of Type of Bridges .....	63
<b>7</b>	<b>PREPARE THE DESIGN.....</b>	<b>66</b>
7.1	DESIGN OF BRIDGES.....	66
7.1.1	Basic Considerations .....	66
7.1.2	Design Standards.....	66
7.1.3	Bridge Deck Slabs and Girder.....	66
7.1.4	Superstructure, Substructure and Foundation.....	69
(1)	Cast-in-situ 2-webbed Prestressed Concrete Slab-deck bridge for Ghyampe and Bhyakure .....	69
(2)	Reinforced Concrete Continuous Slab bridge with walls and raft foundation for Mamti .....	70
7.1.5	Approach Slab .....	71
7.1.6	Construction Plan of the Bridge .....	71
7.1.7	Considerations in Standard Design of PC Post-tensioned 2-webbed Bridge cis on all staging .....	72
7.1.8	Geometrical Shape of River Training Structure .....	78
7.1.9	Design Return Period of River Training Structure and Drainage Facilities .....	78
7.1.10	Determination of Vertical Clearance of the River Training.....	78
7.1.11	Determination of Scouring Depth for River Training .....	79
7.1.12	Consideration of Retaining Wall and Guide Bank Structures for River Training .....	80
7.1.13	Design of the Floor Protection Works for River Training Structure and Bed Protection.....	82
(1)	Launching Apron for Open Foundation and Guide Bank.....	82
7.1.14	Drainage Structure for Temporary Detour Operation.....	84
7.1.15	Approach Road.....	85

(1)	Design Criteria .....	85
(2)	Pavement .....	85
(3)	Slope Protection .....	85
7.2	COST ESTIMATION .....	86
7.2.1	Norms for Rate Analysis of Road and Bridge Works .....	86
(1)	Description of Items .....	86
(2)	Working Conditions.....	86
7.2.2	Approved District Unit Rates .....	86
(1)	Labor Wage Rates and Construction Materials Rates .....	86
(2)	Modification in Labor Wage as per the prevailing Provisions of Labor Act.....	87
(3)	Material Cost .....	87
(4)	Equipment .....	87
(5)	Kabhre District and /or Sindhuli District .....	87

## List of Tables

Table 1-1	Output No. 3: Narrative Summary and Activities .....	1
Table 1-2	Plan of Operation of Output 3 .....	2
Table 2-1	Details of Construction Progress of Sindhuli Road .....	3
Table 2-2	Comparative Chart of Strategic Road Network .....	4
Table 2-3	Candidates of Damaged Five (5) Causeway .....	5
Table 2-4	Causeways' Record of Damages and Traffic Obstructions by Rainfall and Flood .....	6
Table 2-5	Preliminary Evaluation of the Damaged Causeway Sites updated in September 2020 .....	8
Table 2-6	Candidates of the Pilot Project for Restoration of the Damaged Causeway .....	8
Table 3-1	Detailed Activities of Topographic Survey .....	10
Table 3-2	Detailed Location and Investigation of Geotechnical Survey .....	10
Table 3-3	Determination of Permissible Bearing Capacity .....	12
Table 3-4	Safe Bearing Capacity by IS:1904 .....	12
Table 3-5	Type of Bearing Stratum and Permissible Bearing Capacity .....	13
Table 3-6	Design N-value for Spring Support of Foundation Base below Raft Foundation .....	13
Table 3-7	Field Investigation for Ghyampe Causeway .....	14
Table 3-8	Field Investigation for Mamti Causeway .....	14
Table 3-9	Field Investigation for Bhyakure Causeway .....	15
Table 4-1	Monthly Rainfall of Nepalthok .....	16
Table 4-2	Annual Maximum Daily Rainfall of Nepalthok .....	17
Table 4-3	Design Daily Rainfall of Nepalthok .....	18
Table 4-4	Design Daily Rainfall of Stations along the Sindhuli Road .....	19
Table 4-5	Design Short Duration Rainfall of Kathmandu Airport .....	20
Table 4-6	Design Rainfall Depth of Various Durations of Nepalthok .....	20
Table 4-7	IDF-Curve Constants of Nepalthok .....	21
Table 4-8	Design Rainfall Intensity of Various Durations of Nepalthok .....	21
Table 4-9	Catchment Area of Tributaries .....	22
Table 4-10	Kerby's Retardance Coefficient .....	23
Table 4-11	Parameters for Estimation of Travel Time of Overland Flow .....	23
Table 4-12	Hydrologic Soil Groups Defined by Soil Conservation Services .....	23
Table 4-13	Proposed Curve Numbers (CN) by SCS .....	23
Table 4-14	Parameters for Estimation of Travel Time of Channel Flow .....	24
Table 4-15	Time of Concentration of Flow in the Tributaries .....	24
Table 4-16	Rainfall Intensity for Time of Concentration Duration (10-year Return Period) .....	24
Table 4-17	Rainfall Intensity for Time of Concentration Duration (25-year Return Period) .....	25
Table 4-18	Rainfall Intensity for Time of Concentration Duration (50-year Return Period) .....	25
Table 4-19	Rainfall Intensity for Time of Concentration Duration (100-year Return Period) .....	25
Table 4-20	Guidance of Runoff Coefficient P .....	26
Table 4-21	Estimated Peak Flood Discharge in Tributaries .....	26
Table 5-1	Riverbed Gradient and Types of Debris Flow .....	29
Table 5-2	Deposit Characteristics of Debris Flow .....	29
Table 5-3	River Gradient and Nature of Debris Flow based on Material Type .....	30
Table 5-4	Bridge Pier Construction Possibility in River .....	31
Table 5-5	Bridge Pier Construction Possibility in River (Modified Version) .....	31
Table 5-6	Value of Volumetric Sediment Concentration and Nature of Debris Flow .....	33
Table 5-7	Summary of Peak Flood Discharge Coefficient of Debris Flow .....	33
Table 5-8	Manning's Rugosity Coefficient n-value .....	35
Table 5-9	Waterway Opening and Bed Gradient Conditions for Open Channel Design .....	35
Table 5-10	Analysis of Velocity and Water Depth in Peak Flood Discharge .....	36
Table 5-11	Determination of the Width by the Linear Waterway at HFL .....	39
Table 5-12	Historical Record of the Waterway Structures Completed in Sindhuli Road .....	39
Table 5-13	The list and Characteristics of 12 nos. Box-type Causeways in Sindhuli Road Section III .....	40
Table 5-14	Present Conditions of Three Causeways which were built with 1/3rd Constriction .....	40
Table 5-15	Comparison of Technical Parameters for two Different Waterways of the Bridges .....	42
Table 5-16	Comparison of two Waterways including Social Aspects .....	43
Table 5-17	Summary of Structures Completed in Sindhuli Road .....	44
Table 5-18	Selection Policy of a Pier in Waterway .....	45

Table 5-19	Required Vertical Clearance against Two type of Flow at Various Gradient .....	46
Table 5-20	Characteristics of the Pilot Project Site Tributaries for Hydraulic Analysis.....	47
Table 5-21	Vertical Clearance under different cases .....	47
Table 5-22	Flow Water Depth at Debris-Flow and Flood-Flow, Calculation by Manning’s Equation .....	48
Table 5-23	Hight of Margin for Sediment-flow .....	49
Table 5-24	Hight of Margin for Flood-flow .....	49
Table 5-25	Minimum Free Board for Bridge from the design HFL .....	49
Table 5-26	Calculation of Vertical Clearance Case 1 against Passing of Highly Viscous Debris-flow .....	50
Table 5-27	Calculation of Vertical Clearance Case 2 considering Sedimentation of Debris-flow .....	51
Table 5-28	Calculation of Vertical Clearance Case 3, Specific Energy Head .....	51
Table 5-29	Summary of Vertical Clearance by Linear Waterway at HFL and Specific Energy .....	51
Table 5-30	Determination of D50 and D90 Size Particles (Sieve Analysis at field).....	53
Table 5-31	Calculation of Flow Water Depth at Adequate Margin of Safety by Manning’s Equation .....	54
Table 5-32	Scour Depth Calculation by IRC:78-2014 .....	55
Table 5-33	Scour Depth Calculation by Faraday and Charlton Equation .....	56
Table 5-34	Scour Depth Calculation by Blench Equation.....	57
Table 5-35	Summary of Scour Depths by Various Equations and Footing Embedded Depth.....	57
Table 5-36	Summary of the Bridge Structural Dimension .....	57
Table 6-1	Alternative List of Bridge Type.....	59
Table 6-2	Illustration of Alternatives .....	60
Table 6-3	Comparison among Various Alternative Bridges of Restoration of Causeway .....	61
Table 6-4	Evaluation of the Proposed Type of Bridges.....	63
Table 6-5	Determined Bridge Type and Structural Details .....	64
Table 6-6	Summary of the Bridge Structure and River Training Works .....	65
Table 7-1	Characteristics Strength of Concrete.....	67
Table 7-2	Load Combinations and Permissible Stress .....	68
Table 7-3	Return Period for River Training and Drainage Facilities .....	78
Table 7-4	Calculation of Vertical Clearance for River Training .....	79
Table 7-5	Scour Depth Calculation for River Training by IRC: 78-2014 .....	79
Table 7-6	Selection Criteria for Retaining Wall and Guide Bank in River Training.....	80
Table 7-7	Selection Criteria for Bed Protection for Scour Depth .....	82
Table 7-8	Design of Guide Bank by Boulders.....	82
Table 7-9	Design of Guide Bank by Flexible Gabion Mattress .....	82
Table 7-10	Estimated Sizes of Stone for Rip-Rap under Various Riverbed Slopes .....	83
Table 7-11	Scour Depth Calculation for River Training by IRC:78-2014 .....	84

## List of Figures

Figure 1-1	Project Implementation Structure .....	2
Figure 2-1	Sindhuli Road .....	3
Figure 2-2	Record of Registration of All Types of Vehicles (cumulative) in Bagmati Zone .....	4
Figure 2-3	Restoration Candidate Sites of the Pilot Project in Sindhuli Road .....	5
Figure 3-1	Arrangement SPT .....	12
Figure 4-1	Average Monthly Rainfalls in Project Area .....	17
Figure 4-2	Annual Maximum Daily Rainfall of Nepalthok .....	18
Figure 4-3	Lognormal Distribution Fitting of Maximum Rainfall of Nepalthok .....	18
Figure 4-4	Isohyets of 100-year Daily Rainfall of the Project Area .....	19
Figure 4-5	The IDF-Curve of Nepalthok.....	21
Figure 4-6	Catchment Area Map .....	22
Figure 4-7	Definition Sketch of Broad Crested Weir .....	26
Figure 4-8	Real time video at peak flow Bhyakure on 12th July 2019 .....	27
Figure 4-9	Rainfall Record of Nepalthok on 12th July 2019 .....	27
Figure 5-1	Riverbed Gradient and Nature of Debris-flow .....	30
Figure 5-2	Pattern Diagram of Flow Type and Maximum Wave Height.....	31
Figure 5-3	Present Condition of Gangate Khola Causeway, Sindhuli Road (Section-III) .....	41
Figure 5-4	Present Condition of Chainpur Khola Causeway, Sindhuli Road (Section-III).....	41
Figure 5-5	Present Condition of Dhamile Khola Causeway, Sindhuli Road (Section III).....	42
Figure 5-6	Case-1, Waterway Width 40m, Illustration on Social Aspects – Bhyakure Tributary .....	43
Figure 5-7	Case-2, Waterway Width 80m, Illustration on Social Aspects – Bhyakure Tributary .....	44
Figure 5-8	Definition of Two Cases of Vertical Clearance .....	45
Figure 5-9	Definition Sketch of Debris-flow and Sediment-flow.....	48
Figure 5-10	Definition Sketch of Vertical Clearance for Open Foundation.....	49
Figure 5-11	Definition Sketch of Vertical Clearance for Raft Foundation.....	50
Figure 5-12	Image Analysis for Sieve Grading.....	52
Figure 5-13	Representative Graph of Image analysis of Particle Size Distribution at Ghyampe .....	53
Figure 5-14	Blench Fb “Zero bed factor” .....	56
Figure 7-1	Designed Compound Wall .....	81
Figure 7-2	Designed Guide Bank .....	81
Figure 7-3	Size of Riprap Stones .....	83

## ANNEXES

Annex 1	Letter (Minutes of Meeting)
Annex 2	TOR for IEE
Annex 3	Topographical Survey
Annex 4	Geotechnical Survey
Annex 5	Hydrological and Hydraulic Study Report
Annex 6	Structure Analysis for RC continuous Slab Bridge
Annex 7	Structure Analysis for PC Post-tensioned Bridge
Annex 8	Design for River Training Work
Annex 9	Quantity Calculation
Annex 10	Drawings
Annex 11	Abstract of Cost

## Abbreviations

AADT	Average Annual Daily Traffic
AASHTO	Association of American State Highway and Transportation Officials
ADB	Asian Development Bank
AM	Asset Management
APMP	Annual Road Maintenance Plan
BES	Brief Environmental Study
cis	Cast-in-situ
C/P	Counter Part
DCID	Development Cooperation Implementation Division
DDC	District Development Committee
DDG	Deputy Director General
DOHM	Department of Hydrology and Meteorology
DOR	Department of Roads
DOTM	Department of Transport Management
DR	District Road
DWIDM	Department of Water Induced Disaster Management (former DWRI)
DWRI	Department of Water Resources and Irrigation
EIA	Environmental Impact Assessment
EIS	Emergency Information System
EMP	Environmental Management Plan
EOJ	Embassy of Japan
EPR	Environment Protection Rules
ESD	Environmental Screening Method
FR	Feeder Road
Pre-F/S	Pre-Feasibility Study
GESU	Geo-Environmental & Social Unit
GOJ	Government of Japan
GON	Government of Nepal
HFL	Highest Flood water Level
IEE	Initial Environmental Examination
IRC	Indian Roads Congress
IS	Indian Standard
JICA	Japan International Cooperation Agency
MOPIT	Ministry of Physical Infrastructure and Transport
MOEWRI	Ministry of Energy, Water Resources & Irrigation
JCC	Joint Coordinating Committee
PC	Prestressed Concrete
PDCA	Plan-Do-Check-Action
PDM	Project Design Matrix
PMU	Project Management Unit
PO	Plan of Operation
PPA	Public Procurement Act
PSC	Pre-Stressed Concrete
RBN	Roads Board Nepal
RC	Reinforced Concrete
R/D	Record of Discussion
ROW	Right of Way
SPT	Standard Penetration Test
SRN	Strategic Road Network
SRDMU	Sindhuli Road Disaster Management Unit
SRMU	Sindhuli Road Maintenance Unit
SROM2	The Project for the Operation and Maintenance of the Sindhuli Road Phase 2
TOR	Terms of Reference
VDC	Village Development Committee
WECS	Water and Energy Commission Secretariat



# 1 Pilot Projects for Restoration of Damaged Causeways of the Sindhuli Road

## 1.1 Introduction

### 1.1.1 Background

Within the framework of the agreement on Technical Cooperation signed on September 3, 2003, a Record of Discussion (hereinafter referred as “the R/D”) was signed on April 11, 2018 among Department of Roads (DOR), MOPIT, Department of Water Induced Disaster Management (Department of Water Resources and Irrigation, DWRI, at present), Roads Board Nepal (RBN) and Japan International Cooperation Agency Nepal Office (hereinafter referred as “JICA”) to develop a detailed planning survey for the Project for the Operation and Maintenance of the Sindhuli Road Phase 2 (hereinafter referred as “the Project”).

The Project will be implemented in accordance with the basic principles for Technical Cooperation, 2019 and arrangements agreed on the R/D.

During the meeting, several main points were discussed and presented in *Annex-1*, one of the points discussed (point No. 6) was related to the Pilot Project for restoration of damaged causeways of the Sindhuli Road.

### 1.1.2 Overall Goal, Project Purpose and Outputs of the Project

As described in the Project Design Matrix (PDM), the overall goal of the Project is the maintaining of the safe and smooth road traffic along the Sindhuli Road.

Similarly, the Project’s purpose is the strengthening the overall operation and maintenance system of the Sindhuli Road.

The Output No. 3 of the PDM (Capacity to restore the damaged causeways of Sindhuli Road is enhanced by the Pilot Projects) has been explained in the Table 1-1 below.

Table 1-1 Output No. 3: Narrative Summary and Activities

Narrative Summary	Objectively Verifiable Indicators	Means of Verification	Important Assumption	Achievement	Remarks
Output-3 Capacity to restore the damaged causeways of Sindhuli Road is enhanced by the Pilot Projects.	3-1 The Pilot Projects for restoration of the damaged causeways are undertaken and completed in cooperation with DOR and DWRI 3-2 The Project related issues including causeway disaster countermeasures are presented by individual counterpart at the workshops and the JCC Meeting	3-1 Implementation Schedule of the Pilot Project.  3-2 Results of Seminars and Workshops, a manual and training reports.			
Activities 3-1 Conduct the site survey of the Sindhuli Road and select the sites for pilot project 3-2 Conduct the natural condition survey including EIA, topographic survey and geotechnical survey 3-3 Prepare the design, drawings, quantity, and cost estimation and tender documents for DOR support for the pilot project 3-4 Implementation of the pilot projects by DOR in collaboration with DWRI 3-5 Conduct on training on planning, design, construction supervision, maintenance etc. for the C/P through the pilot project 3-6 Prepare the manual about the planning, investigation and design method of the causeway rehabilitation 3-7 Conduct a sharing workshops on pilot projects 3-8 Conduct a technical study tour in Nepal					

### 1.1.3 Plan of Operation

The Plan of Operation (PO) of Output No. 3: Capacity to restore the damaged causeways of Sindhuli Road is enhanced by the Pilot Projects as stated in the R/D has been presented in the Table 1-2 below.

# 1 Pilot Projects for Restoration of Damaged Causeways of the Sindhuli Road

## 1.1 Introduction

### 1.1.1 Background

Within the framework of the agreement on Technical Cooperation signed on September 3, 2003, a Record of Discussion (hereinafter referred as “the R/D”) was signed on April 11, 2018 among Department of Roads (DOR), MOPIT, Department of Water Induced Disaster Management (Department of Water Resources and Irrigation, DWRI, at present), Roads Board Nepal (RBN) and Japan International Cooperation Agency Nepal Office (hereinafter referred as “JICA”) to develop a detailed planning survey for the Project for the Operation and Maintenance of the Sindhuli Road Phase 2 (hereinafter referred as “the Project”).

The Project will be implemented in accordance with the basic principles for Technical Cooperation, 2019 and arrangements agreed on the R/D.

During the meeting, several main points were discussed and presented in *Annex-1*, one of the points discussed (point No. 6) was related to the Pilot Project for restoration of damaged causeways of the Sindhuli Road.

### 1.1.2 Overall Goal, Project Purpose and Outputs of the Project

As described in the Project Design Matrix (PDM), the overall goal of the Project is the maintaining of the safe and smooth road traffic along the Sindhuli Road.

Similarly, the Project’s purpose is the strengthening the overall operation and maintenance system of the Sindhuli Road.

The Output No. 3 of the PDM (Capacity to restore the damaged causeways of Sindhuli Road is enhanced by the Pilot Projects) has been explained in the Table 1-1 below.

Table 1-1 Output No. 3: Narrative Summary and Activities

Narrative Summary	Objectively Verifiable Indicators	Means of Verification	Important Assumption	Achievement	Remarks
Output-3 Capacity to restore the damaged causeways of Sindhuli Road is enhanced by the Pilot Projects.	3-1 The Pilot Projects for restoration of the damaged causeways are undertaken and completed in cooperation with DOR and DWRI 3-2 The Project related issues including causeway disaster countermeasures are presented by individual counterpart at the workshops and the JCC Meeting	3-1 Implementation Schedule of the Pilot Project.  3-2 Results of Seminars and Workshops, a manual and training reports.			
Activities 3-1 Conduct the site survey of the Sindhuli Road and select the sites for pilot project 3-2 Conduct the natural condition survey including EIA, topographic survey and geotechnical survey 3-3 Prepare the design, drawings, quantity, and cost estimation and tender documents for DOR support for the pilot project 3-4 Implementation of the pilot projects by DOR in collaboration with DWRI 3-5 Conduct on training on planning, design, construction supervision, maintenance etc. for the C/P through the pilot project 3-6 Prepare the manual about the planning, investigation and design method of the causeway rehabilitation 3-7 Conduct a sharing workshops on pilot projects 3-8 Conduct a technical study tour in Nepal					

### 1.1.3 Plan of Operation

The Plan of Operation (PO) of Output No. 3: Capacity to restore the damaged causeways of Sindhuli Road is enhanced by the Pilot Projects as stated in the R/D has been presented in the Table 1-2 below.

Table 1-2 Plan of Operation of Output 3

SN	Activities	Year	Year - I				Year - II				Year - III				Issues & Countermeasures	
			1	2	3	4	1	2	3	4	1	2	3	4		
3-1	Conduct the Site Survey of the Sindhuli Road and select the Sites for the Pilot Project	Plan	█													
		Actual	█													
3-2	Conduct the natural condition Survey including EIA, topo and geological investigations	Plan	█	█												
		Actual	█	█	█											
3-3	Prepare the Design, Cost Estimation and Tender documents for the pilot Project	Plan		█	█	█										
		Actual		█	█											
3-4	Implementation of the Pilot Project in collaboration with DWRI	Plan				█	█	█	█	█	█	█	█	█	█	█
		Actual				█	█	█	█	█	█	█	█	█	█	█
3-5	Conduct on the Job training on planning, design, construction supervision, maintenance etc. for the C/P through the Pilot Project	Plan	█	█	█	█	█	█	█	█	█	█	█	█	█	█
		Actual	█	█	█	█	█	█	█	█	█	█	█	█	█	█
3-6	Prepare the manual about the Planning, investigation and design method of the causeway rehabilitation	Plan													█	
		Actual													█	
3-7	Conduct a sharing workshops on pilot projects	Plan	█	█	█	█	█	█	█	█	█	█	█	█	█	█
		Actual	█	█	█	█	█	█	█	█	█	█	█	█	█	█
3-8	Conduct a technical study tour in Nepal	Plan														█
		Actual														█

1.1.4 Implementation Structures

The Implementation Structure for SROM2 has been presented in the figure 1-1 below

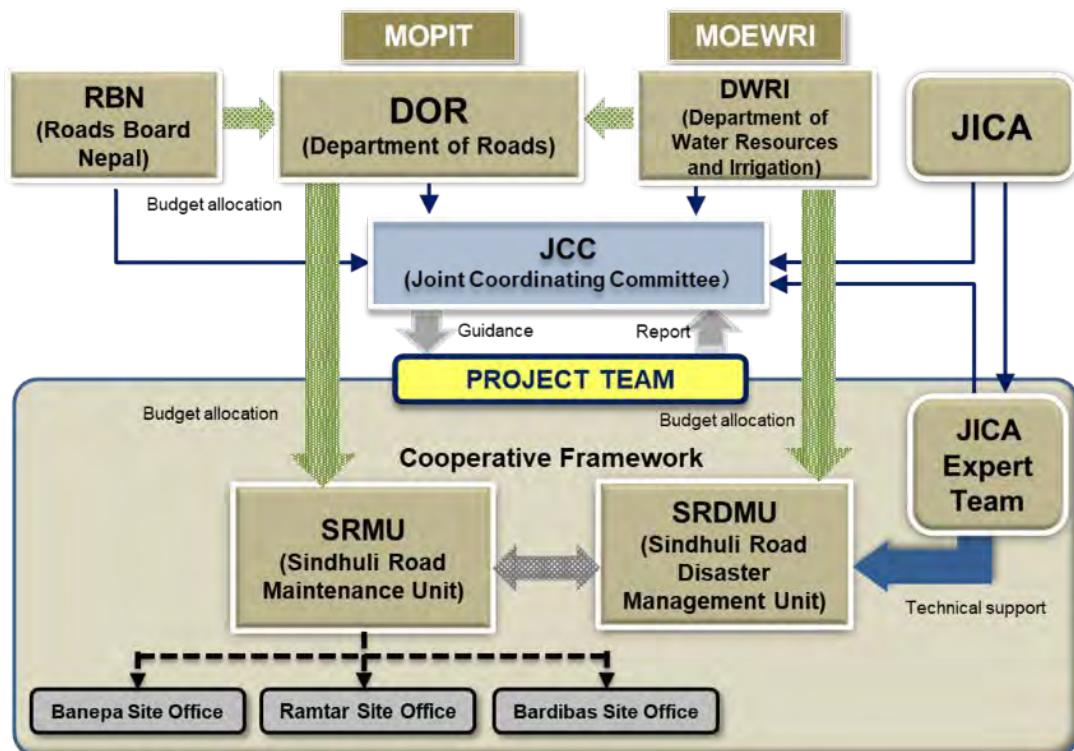

Figure 1-1 Project Implementation Structure

Source: JICA Expert Team

## 2 Selection of the Sites for Pilot Project

### 2.1 Sindhuli Road Project

#### 2.1.1 Present Condition

Sindhuli Road, with its total length of 160 km, connects Dhulikhel on the Arniko Highway (25 km eastward from Kathmandu) to Bardibas on the East-West Highway crossing the Terai Plain. Considering local conditions such as geographical features, this road is divided into four sections, namely, Section I (37 km Bardibas – Sindhuli Bazar), Section II (36 km Sindhuli Bazar – Khurkot), Section III (36 km Khurkot – Nepalthok) and Section IV (50 km Nepalthok – Dhulikhel) as shown in figure 2-1 below.



Figure 2-1 Sindhuli Road

The construction progress of Sindhuli Road including cross drainage works has been presented in Table 2-1 below.

Table 2-1 Details of Construction Progress of Sindhuli Road

S.N.	Section	Section Length	Main Structure	Remarks
Section I	Bardibas - Sindhuli	37 km	9 bridges	1996 to 1998
			3 box type causeways	
			14 causeways (flood type)	
Section II	Sindhuli Bazar - Khurkot	36 km	1 bridge	2001 to 2009
			2 box type causeways	
Section III	Khurkot - Nepalthok	37 km	12 box type causeways	2009 to 2015 2015.3 completed
Section IV	Nepalthok - Dhulikhel	50 km	5 bridges	1998 to 2005
			8 causeways (flood type)	
Total		160 km	54 nos.	

Source: JICA Expert Team

As presented in the Table 2-1 above, there are 15 number of bridges and 39 different type of causeways in the Sindhuli Road. The Sindhuli Road is classified as National Highway, H06 (as per Clause 3A), of Hilly, Mountain and Steep Terrain class (Classification, Clause 3.1) with carriageway width of 5.5m intermediate lane (Clause 11.10) of NRS2070.

The Sindhuli Road is a major connecting road which joins Kathmandu to the Terai area and Indian border. This plays vital roles for the security, safety and economic growth of Nepal. Utilizing this road will consequently shorten the travel distance and travel time, which will benefit both agricultural production transport and long-distance bus trips. Furthermore, it is expected that the shortening of travel time to Sindhuli, Ramechhap and Kavrepalanchok districts will result in the reduction of travel cost and contribute to stable transport and industrial promotion along the road.

### 2.1.2 Traffic Increase

Government of Nepal has given high priority for the development of transport sector, especially to the road sector for few decades. As a result, the expansion of road networks connecting urban and rural areas is increased.

Table 2-2 below shows the comparison of SRN road length, influenced population and density for the period of 1998 to 2015, that is also the period of Sindhuli Road Construction. The length of Strategic Road developed in that period is about 3 times more. Same way there is change in other parameters like influenced population and the density.

Table 2-2 Comparative Chart of Strategic Road Network

Comparative Chart of Strategic Road Network Length Influenced Population and Density (1998-2015)

Year	Description	Road Length				Influenced Population no./km	Density km/100 sq.km
		Bitumen BT km	Gravel GR km	Earth ER km	Total km		
1998	9 <sup>th</sup> (5-year Plan 2054)	2905	1656	179	4740	-	3.22
2000		2974	1649	171	4794	3901 *1	3.26
2002	10 <sup>th</sup> (5-year Plan 2058)	3029	1664	168	4861	4763 *2	3.30
2004		3495	884	614	4993	4636 *2	3.39
2006/07		4258	2062	3079	9399	2463 *2	6.39
2009/10		4952	2065	3818	10835	2137 *2	7.36
2011/12		5574	1888	4174	11636	2288 *3	7.91
2013/14		6369	1735	4389	12494	2131 *3	8.49
2015/16		6823	2044	4031	12898	2064 *3	8.76

\*1: Population Census 1991, \*2: Population Census 2001, \*3: Population Census 2011

Source: DOR

Apart from the strategic road networks, many feeder roads and district roads have been realized in the same period. The Sindhuli Road is not only serving to Kathmandu-Terai connection, it is also catering to all traffic that is running to many districts adjacent to this road (like Kabhre, Sindhuli etc.) as well as other far districts (like Okhaldhunga, Solukhumbu, Udayapur etc.). After construction of bridges across Sunkoshi River at Khurkot and Ghurmi, the traffic inflow from eastern mid hill districts have been increased heavily. During rainy season, the traffic flow has been experienced halt at Sindhuli Road at different causeway sections for few minutes to several hours. That has created a big pressure to look for alternative bridge structures across these rivers. Figure 2-2 below shows the record of registration of all types of vehicles (cumulative) registered in Bagmati Zone since 1989 to 2013.

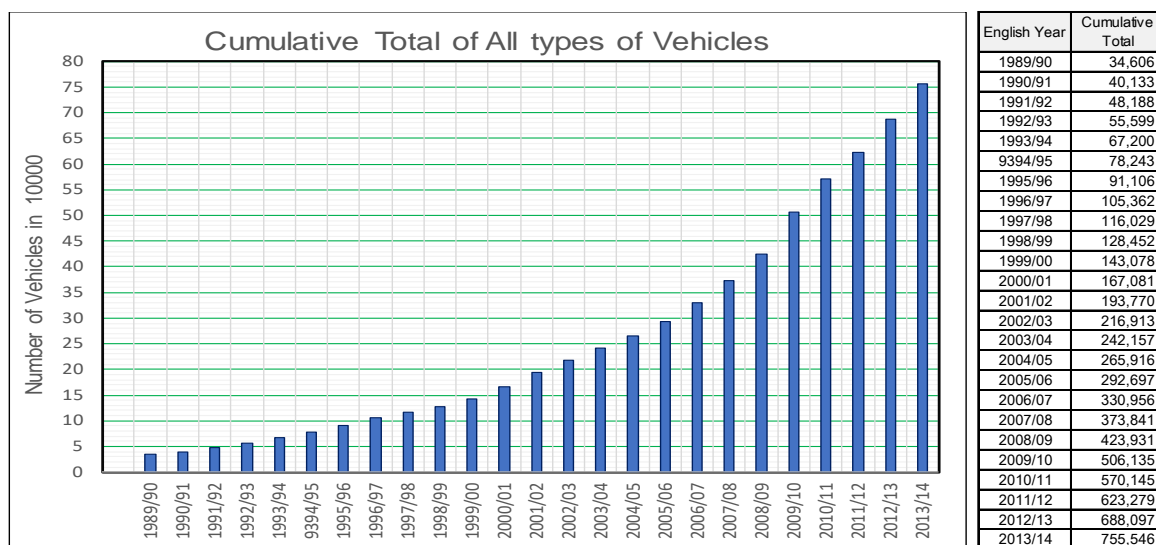

Source: DOTM, GON

Figure 2-2 Record of Registration of All Types of Vehicles (cumulative) in Bagmati Zone

### 2.1.3 Restoration of Causeways

In order to address the need of bridges in lieu of existing causeways, the Project has considered restoration of existing damaged causeways to appropriate bridge structures in five (5) probable sites on Section IV of Sindhuli Road.

Five (5) damaged sites of causeway/roadway were recognized in 2017 through the Pre-survey for the Project for the Operation and Maintenance of the Sindhuli Road Phase 2 by JICA as presented in the figure 2-2 and Figure 2-3 below.

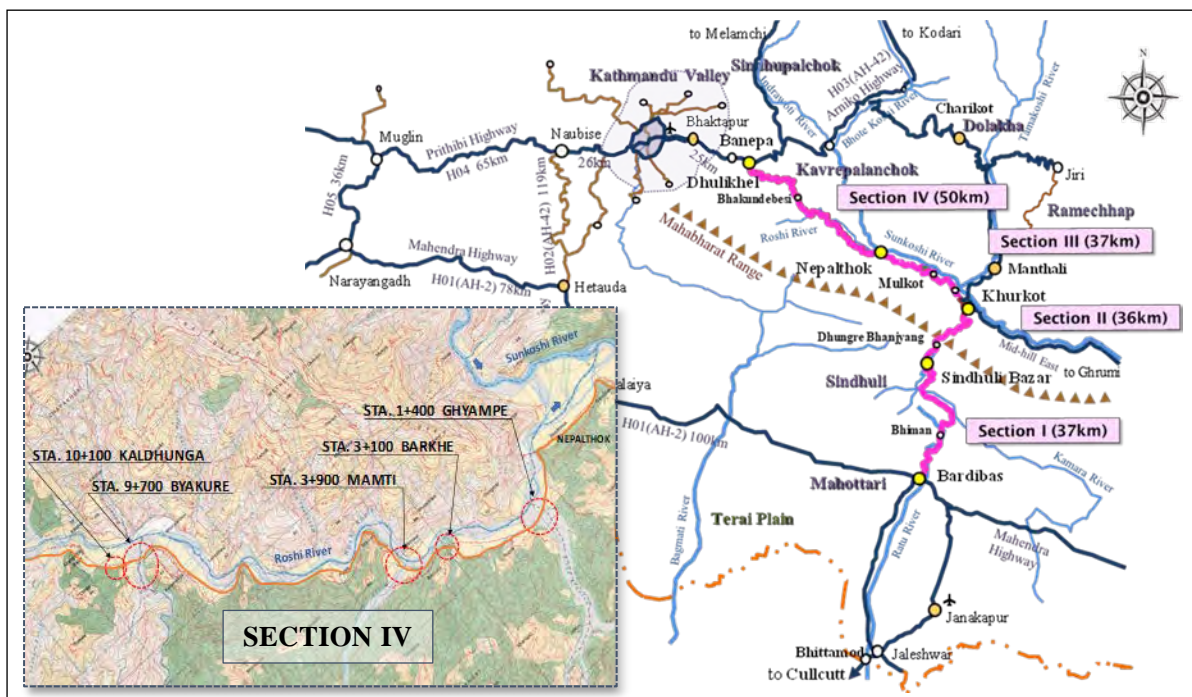

Figure 2-3 Restoration Candidate Sites of the Pilot Project in Sindhuli Road

S N	Chainage and STA. * in Section IV	Tributary /Location Name	Constructed Waterway Crossing Structure (Present Condition)	Completed Construction Year (Elapsed time)	Flow Water in Normal Condition	No. 10 <sup>th</sup> Boulder size at surrounding
1.	Ch. 111+400 (STA. 1+400)	Ghyampe	Causeway (Flood type)	February 2003 (17 years)	Few	1 m
2.	Ch. 113+100 (STA. 3+100)	Barkhe	Causeway (Flood type)	February 2003 (17 years)	Non	0.5 m
3.	Ch. 113+900 (STA. 3+900)	Mamti	Vented type Causeway with 3 pipe culverts (Dia. 60cm pipes are blocked)	February 2003 (17 years)	Constant flow	0.5 m
4.	Ch. 109+700 (STA. 9+700)	Bhyakure	Vented type Causeway with 2 pipe culverts (Di. 90m pipes are working)	February 2003 (17 years)	Constant flow	1 m
5.	Ch. 120+100 (STA. 10+100)	Kaldhunga	Roadway: original by DBST (Constructed concrete pavement by DOR)	February 2003 (17 years)	Non	Granular 0.1~0.2m











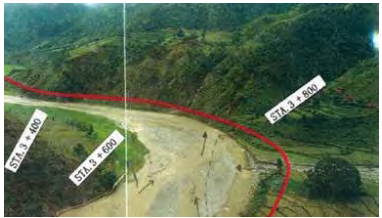



\*: STA. from Nepalthok to Dhulikhel in Section IV, Sindhuli Road

Source: JICA Expert Team

2.1.4 Evaluation of the Damaged Causeway for Restoration

An evaluation of damaged sites (flood type causeways) of Section IV revised after the abnormal rainfall and damaged by debris-flow in July 2019 has been made based on various parameters as presented in Table 2-4 below.

Table 2-4 Causeways' Record of Damages and Traffic Obstructions by Rainfall and Flood

Year	111+400 Ghyampe CW	113+900 Mamti CW	119+700 Bhyakure CW
2000	View of fan before planning 	View of fan before planning 	View of fan before planning 
2002	Constructed CW (floodway)	Constructed CW (floodway)	Constructed CW (floodway)
2002/7	Debris-flow widely spread over the road 	Debris-flow widely spread over the road 	Debris-flow widely spread over the road 
2005	Debris-flow widely spread		Debris-flow widely spread
2012 /2014	Crushing plant mobilized 	2014 Crushing plant mobilized 	Crushing plant mobilized 
2013	Ordinally condition 	2014 CW had been maintained 	Ordinally condition 
2014	Debris-flow scoured D/S side of 8m height drop wall 	Debris-flow had damaged maintained CW 	Debris-flow scoured D/S side 8m height drop wall 

<p>2014/12</p>	<p>Protection by gabion box walls had been done</p> 	<p>Ordinally condition</p> 	<p>Protection by gabion box walls had been done</p> 
<p>2015</p>		<p>Traffic blockage</p> 	
<p>2018</p>	<p>2019 Condition of the temporary protection wall by gabion</p> 	<p>2019 Ordinally condition</p> 	<p>Left bank (Dhulikhel) side had damaged by flood</p> 
<p>2019/7</p>	<p>Temp. protection wall had been washed away by debris-flow while three days monsoon</p> 	<p>Three days traffic obstruction by debris-flow while three days monsoon</p> 	<p>Temp. protection wall had been washed away by debris-flow while three days monsoon</p> 
<p>2020/7</p>	<p>Temp. protection by gabion wall had completed</p> 	<p>2 times in July, traffic blockage occurred for several hours</p> 	<p>Temp. protection by gabion wall had completed</p> 
<p>2020/9</p>		<p>One time in September traffic blockage occurred</p>	

Source: JICA Expert Team

A preliminary evaluation of the damaged causeway Sites as updated in September 2020 is presented in Table 2-5 below.

Table 2-5 Preliminary Evaluation of the Damaged Causeway Sites updated in September 2020

Evaluation		Chainage	111+400	113+900	119+700
			Ghyampe	Mamti	Bhyakure
1. Risk of Road Collapse	Degree of damage of existing causeway/road		3 High	3 High	3 High
	Risk of road collapse by scouring or erosion		3 High	2 Moderate	3 High
	Over-all judgement		<b>3</b>	<b>2</b>	<b>3</b>
2. Social Impact	Frequently road closure occurred in spite of National Highway		2 Moderate	3 Often	2 Moderate
	Impact of road (bridge) rising on the surroundings		2 Moderate	1 Heavy	2 Moderate
	Less required Land acquisition or relocation of house o/s of ROW		2 Moderate	2 Moderate	2 Moderate
	Over-all judgement		<b>2</b>	<b>3</b>	<b>2</b>
3. Effect and Reproducibility as Technology Transfer	Planning and design difficulty (shoring, temporary plan, etc.)		3 High	3 High	3 High
	Difficulty of construction (flow and debris during flood)		3 High	3 High	3 High
	Stability and erosion of upstream and downstream side of river channel		3 High	2 Moderate	3 High
	Difficulty of traffic management (detour, etc.)		2 Moderate	3 High	2 Moderate
	Over-all judgement		<b>3</b>	<b>3</b>	<b>3</b>
4. Scale of Project Cost Reconstructed by Bridge		2 Moderate	2 Moderate	2 Moderate	
<b>Priority Order of the Project</b>			<b>3</b>	<b>1</b>	<b>1</b>
The Pilot Project			Selected	Selected	Selected

Source: JICA Expert Team

Based on the evaluation procedure shown above, restoration of following causeways will be realized immediately by bridge structures as candidates for the Pilot Project as presented in the Table 2-6 below.

Table 2-6 Candidates of the Pilot Project for Restoration of the Damaged Causeway

SN.	Name of Existing Waterway Crossing Structure	Restoration Structure	Determination	Proposed Priority Order to construct
1	Ghyampe Khola Causeway	Bridge	Pilot Project	<b>3</b>
2	Mamti Khola Causeway	Bridge	Pilot Project	<b>1</b>
3	Bhyakure Khola Causeway	Bridge	Pilot Project	<b>1</b>

Source: JICA Expert Team

As of July 2020, Mamti causeway which has frequent traffic obstructions and effect and reproducibility as technology transfer required, is judged to have the highest priority while the three pilot project sites.

Further studies of these bridge sites will be carried out in the following chapters.

### **3 Natural Condition Survey including EIA, Topography, Geotechnical Investigations**

#### **3.1 Natural Condition Survey Works**

In order to realize the restoration works of three (3) different causeway sites (Ghyampe River, Mamti River and Bhyakure River) as the Pilot Project, following natural conditions surveys need to carryout.

#### **3.2 Environment Impact Assessment (EIA) and/or Initial Environment Examination (IEE) Survey**

Based on the prevailing environmental laws and regulations of Nepal, the necessary environmental study is needed to be carried out.

As stipulated in Schedule-1, D.4, (Pertaining to Rule No. 3) of Environment Protection Rules 1997 Nepal, an Initial Environmental Examination (IEE) is necessary for construction of major bridges. Even though the construction of the proposed Pilot Project is the restoration of existing causeway structure and the activities associated in respect to the restoration works are mostly limited within the right of way of the Sindhuli Road.

However, the Terms of References (TOR) of IEE for the restoration of the proposed Pilot Projects have been prepared and submitted to the Sindhuli Road Project, the Proponent (See *Annex-2*) in accordance to the provision of Rule No. 3 which states as “Initial Environment Examination or Environment Impact Assessment to be made: A proponent shall be required to carry out the initial environmental examination of the proposals mentioned in Schedule (1) and EIA of the proposals mentioned in Schedule 2”.

#### **3.3 Topographical Survey**

As discussed in the JCC-1 meeting, JICA Expert Team selected one contractor and assigned to the damaged causeway sites of Ghyampe, Mamti and Bhyakure, and for the topographical survey. The scopes and expected output of the topographical survey have been summarized and presented below.

- 1) Bench mark description sheets (hardcopy, PDF and softcopy)
- 2) Raw data (coordinate table: X, Y, Z) from the topographic survey (PDF and softcopy in ASCII CSV text format).
- 3) Check/validation sheet for accuracy of the topographic survey (PDF and softcopy in appropriate format, e.g., MS Word, MS Excel, or PDF).
- 4) Digital Elevation Models (DEMs) having one (1) meter grid spacing (PDF and softcopy in DXF format or ESRI Shapefile format).
- 5) Contour lines with an interval of one (1) meters (PDF and softcopy in DXF format).
- 6) Topographic maps prepared at a scale of 1:500 (hardcopy, PDF and softcopy in DXF format).
- 7) Longitudinal profile and cross sections of road (engineering maps) prepared at a scale of 1:500 (hardcopy, PDF and softcopy in DXF format).
- 8) Water course profile and cross sections of river/stream (engineering maps) prepared at a scale of 1:500 (hardcopy, PDF and softcopy in DXF format).

The detailed activities of topographic survey are presented in Table 3-1.

Table 3-1 Detailed Activities of Topographic Survey

S N	STA. Location	Bench Mark Setting  (nos.)	Plan and Contour Mapping			Longitudinal and Cross Section Survey for Road	
			Topograp hic Survey (sq.km)	River Course Profile Drawing (section)	River Cross Section Drawing (section)	Longitudinal Section Survey (liner m)	Cross Section Survey (liner m)
1	1+400 Ghyampe	3	0.120	1	5	375	800
2	3+900 Mamti	3	0.034	1	5	175	400
3	9+700 Bhyakure	3	0.050	1	5	200	450
4	10+100 Kaldhunga	3	0.045	1	5	250	550

Source: JICA Expert Team

Accordingly, the Contractor mobilized to the causeway sites in first week of June 2019 and conducted the survey works and presented the final outcome in required format to the JICA Expert Team. The reports of Topography Survey submitted by the Contractor have been attached in *Annex-3 Topographic Survey*.

### 3.4 Geotechnical Survey

During construction of Sindhuli Road, 15 number of bridges of different types and 17 number of box type causeways were constructed. That included the damaged causeways also. The references of these structures will be taken up for deciding geotechnical investigation. Some additional investigation was conducted on September 2019 on each individual site proposed in SR0M2 for confirmatory purposes as explained in the following points.

#### 3.4.1 Geotechnical Survey based on type of Foundation

In case that the ground and strata conditions around the proposed bridge site is estimated to be a weak or permissible foundation and out of the experience of the office, the geotechnical survey for the bearing strata investigation at the site shall be conducted. Depending on the assumed foundation type of the bridge, the following investigation or consideration are recommended.

- 1) Independent foundation by open foundation or pile foundation:
  - Borehole investigation to confirm the bearing capacity of the bearing strata for open foundation is required.
- 2) Raft Foundation with RC continuous slab bridge (RC box type bridge):
  - At deposition of sediment of alluvial fan
  - At deposition of sediment of alluvial Terai plain
  - Borehole investigation to confirm the bearing capacity of the bearing strata is required depend on the unknown site conditions

#### 3.4.2 Geotechnical Survey of the Work

The Work shall be conducted along the Nepalthok - Dhulikhel road in the Section IV of Sindhuli Road at various places.

Detailed geotechnical surveys are shown in Table 3-2 below.

Table 3-2 Detailed Location and Investigation of Geotechnical Survey

SN.	Location	Assumed Foundation type of the Bridge	Borehole Investigation				Sieve Gradation Test  (nos.)
			Drilling Number  (nos.)	Drilling Length  (l. m)	Standard Penetration Test  (nos.)	Ground Water Table	
1	Ghyampe	Open foundation	2	2 x 16 =32	2 x 5 = 10	Check	1
2	Mamti	Raft foundation	-	-	-	-	1
3	Bhyakure	Open foundation	2	2 x 16 =32	2 x 5 = 10	Check	1

Source: JICA Expert Team

### 3.4.3 Scope of the Work

The contents of the Work are as follows:

Determination of bearing capacity for Ghyampe and Bhyakure Tributaries by borehole investigation

- A. Rotary Drilling
- B. Standard penetration test (SPT N-value) and ground water table monitoring

Determination for scour depth analyses for Ghyampe, Mamti and Bhyakure tributaries

- C. Sieve grading test at site for  $D_{50}$  and  $D_{90}$
- D. Preparation of survey data and output (reporting)

The above Work shall be carried out in order to determine the bridge design conditions at the sites shown and to provide data about these conditions, as required for the design of bridge foundation and river training for scouring analyses for damaged three (3) causeway due to debris/mud/flood flow.

### 3.4.4 Expected Output of Geotechnical Investigation

The expected outputs of geotechnical survey are presented below

- 1) Description of geotechnical investigation with photos
- 2) Drilling record
- 3) Borehole SPT table and location in the profile and plan drawing (CAD data)
- 4) Ground water table at borehole survey
- 5) Bearing capacity evaluation for bridge foundation
- 6) Sieve grading test analysis ( $D_{50}$  and  $D_{90}$  for scour depth analysis)
- 7) Check/validation sheet for accuracy of the Geotechnical survey (PDF and softcopy in appropriate format, e.g., MS Word, MS Excel or PDF).

### 3.4.5 Correction of the SPT N-values

Because of the dominance of gravel and boulder on the riverbed, Dynamic Cone Penetration Test (DCPT) was basically conducted following IS: 4968 (Part II) – 1976. Dynamic Cone Penetration tests was performed by a 50-mm solid cone. The driving energy was applied by a 63.5 kg monkey hammer falling freely through a height of 750 mm onto the drive head. First of all, the cone is driven 100 mm into the soil at the bottom of the bore hole. It is then driven further 200 mm (desirable 300 mm) and the number of blows ( $N_{\text{br}}$  values) required to drive this distance is recorded.

### 3.4.6 Determination of Permissible Bearing Capacity for Open Foundation

While determining the permissible bearing capacity, necessary correction has been made for equivalent N-values (SPT values) observed collected in the field as explained above. Several corrections have been applied in order to finalize the N-values. These corrections include shape factor correction, inclination factor correction, water table position correction, over burden factor correction, hammer energy correction etc. After applying all required corrections, the final bearing capacity of foundation was determined based on the two criteria mentioned below.

- 1) Bearing Capacity by Shear Failure Criterion (IS: 6403-1981) and
- 2) Settlement Limiting to 50 mm depth Criterion (IS: 1904-1986).

#### Characteristics of drilling holes conducted at Ghyampe and Bhyakure Khola.

One drill hole having 16m depth was driven at tentative location of each abutment (two abutments with open foundation, PC Girder Bridge with single span in one bridge) at both of the banks. All four drill holes encountered the bed materials as boulder with gravel. The soil density/ fineness of bed materials is categorized as very dense. The SPT N-values after applying necessary corrections are observed more than 60. The Characteristics of drilling holes including the Permissible Bearing Capacity based on Shear Failure Criteria and Settlement Criteria have been presented in Table 3-3 hereunder. The Overall Arrangement of Geotechnical Investigation has been illustrated as shown in Figure 3-1 below.

Table 3-3 Determination of Permissible Bearing Capacity

Conditions		Geotechnical Survey Location				
		Ghyampe		Bhyakure		
		G1 at A1 Nepalthok	G2 at A2 Dhulikhel	B1 at A1 Nepalthok	B2 at A2 Dhulikhel	
Foundation type of substructure	-	Open foundation	Open foundation	Open foundation	Open foundation	
Foundation Bed	Elevation	m (EL)	575.3	575.3	676.9	676.9
	On Boring depth	m	13/16	14/16	14/16	14/16
Foundation Bed Condition	Material	-	Boulder with gravel	Boulder with gravel	Boulder with gravel	Boulder with gravel
	Soil Density/Fineness	-	Very Dense	Very Dense	Very Dense	Very Dense
	SPT-N value	-	> 60	> 60	> 30-60	> 60
Permissible Bearing Capacity by boring	Foundation size	m x m	10 x 11	10 x 11	10 x 11	10 x 11
	Shear Failure Criteria (IS:6403-1981)	kN/m <sup>2</sup>	5,495	8,771	4,989	12,377
	Settlement Criteria (IS:1904-1986)	kN/m <sup>2</sup>	645	2,605	494	952
Permissible Bearing Capacity adopted value for design (IS:1904-1978)		kN/m <sup>2</sup>	<b>440</b>	<b>440</b>	<b>440</b>	<b>440</b>

Source: JICA Expert Team

### Borehole Investigation and Analysis for the foundation design for Ghyampe and Bhyakure Bridges

Boring investigation with SPT N-value tests has been done at open/independent foundation of the abutments. Site investigation work had started in mid of September 2019 and finalized analysis in December 2019.

Table 3-4 Safe Bearing Capacity by IS:1904

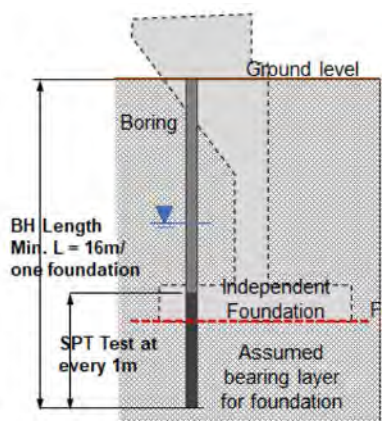

Figure 3-1 Arrangement SPT

Type of soil/rock		Safe capacity kN/m <sup>2</sup>	Remarks Ghyampe, Bhyakure
Rocks	Residual deposits of broken bed rock	880	
	Soft rock	440	
Cohesionless soils	Gravel, sand and gravel	440	Dense
	Coarse sand	440	
	Medium sand, loose gravel	245	
	Fine sand and silt	150	
Cohesive soils	Hard or stiff clay	440	
	Moist clay and sand-clay mixture	100	
	Soft clay	100	
	Very soft clay	50	

Source: IS: 1904-1978

The permissible bearing capacity for purpose for open foundation design has been adopted as 440 kN/m<sup>2</sup> at bearing strata of gravel base as shown in the Table 3-4 above.

The details of output of geotechnical survey are presented in *Annex-4 Geotechnical Survey*.

#### 3.4.7 Estimation of Coefficient of Sub-grade Reaction for Raft Foundation

Raft foundations are found to be quite suitable for small bridges and culverts where the founding strata is soft and has Safe Bearing Capacity (SBC) upto 100 kN/m<sup>2</sup>. The following aspects are to be kept in consideration by Clause 13.5.13, IRC: SP13-2004.

Coefficient of vertical sub-grade reaction for design of a raft foundation is referred by the Japanese road standard shown in Table 3-5. N-value of the bearing strata of deposit sedimentation in alluvial fan is assumed to be N-value 30 for spring support value for raft foundation design.

Table 3-5 Type of Bearing Stratum and Permissible Bearing Capacity

Type of bearing stratum	Relative density	Permissible /safe bearing capacity kN/m <sup>2</sup>	Reference value		Remarks assumed type of Mamti tributary
			Uniaxial compressive strength kN/m <sup>2</sup>	SPT N-value	
Gravel	Very dense	600	-	-	
	Not dense	300	-	-	
Cohesionless soils	Dense	300	-	<b>30 ~ 50</b>	Dense
	Midium dense	200	-	20 ~ 30	
Cohesive soils	Very hard	200	200 ~ 400	15 ~ 30	
	Hard	100	100 ~ 200	10 ~ 15	

Source: Japan road association

Raft foundation is said to be applicable to soft bearing strata (safe bearing capacity shall be equal or more than 100 kN/m<sup>2</sup> (SPT N-value 10), stated in Clause 13.5.13, IRC: SP13-2014.

On the other hand, it has been confirmed from the construction results of the Sindhuli Road Construction Project that the accumulated sediment ground in alluvial fan of tributaries along the Sindhuli road has sufficient bearing capacity for the raft foundation design. In the design for Mamti bridge, SPT N-value 30 was applied as dense gravel of cohesionless soil at bearing strata as explained in Table 3-6 below.

Table 3-6 Design N-value for Spring Support of Foundation Base below Raft Foundation

Location	Bearing Strata	Type of Soil		N-value for Spring Support of Foundation Design
		Gravel, granular soil	Cohesionless soil	
Alluvial fan	Deposit sedimentation	Gravel, granular soil	Cohesionless soil	<b>30</b>
Alluvial plain (Terai Plain)	Soft bearing strata Sand, Clay or fine soil	Fine sand, clay	Cohesive soil	10 Minimum N-value

In the plan of the box type bridges in the alluvial fan along Sindhuli Road, it is judged that the permissible bearing capacity of 300 kN/m<sup>2</sup> can be expected at the minimum in the layer of sediment deposition, so the geotechnical survey for bearing capacity was not conducted at Mamti Bridge.

### 3.5 Field Investigation

Field investigation records for the three pilot project sites are shown Table 3-7, 3-8 and 3-9 as below.

Table 3-7 Field Investigation for Ghyampe Causeway





Subject	Condition	Description
Photo	Site Visit photo after flooding	
Cross section	by Topographical survey Image of linear waterway	
Waterway terrain	Alluvial fan (widely flat)	Alluvial fan formation is relatively old and stable
Mode of running water	Less	It flows when it rains
Mode of debris-flow	Less	Sedimentation of debris-flow ~ sediment-flow
Nature of flow	Debris-flow	Gravel-type debris-flow stopping section
Floating debris	Non	Not observed roots and/or log of driftwood
Flood particle	Boulder	Max. boulder size 1.0m in July 2019 (approx. 10th from the largest particle size)
Bed condition at u/s side	Flat	Alluvial fan plain, 4% slope and developed by the quarry site
Bed condition at d/s side	Open channeled	7% slope and channelized by scouring with flood-flow with 37m width and 8m drop height
Linear waterway width	At site condition	37 m width (widen by flood in July 2019)
Sediment		Less sedimentation at quarry site at u/s Crushing plant in operation with quarry site in u/s
Bearing stratum	Dense	Sediment: shall be checked N-value by geotechnical survey at site for open foundation
Land use	u/s side	Village, public use, cultivated land Operation of quarry and crushing plant at U/S of D/S side
Social aspect		Road level

Table 3-8 Field Investigation for Mamti Causeway

Subject	Condition	Description
Photo	Site Visit after flooding	
Cross section	by Topographical survey Image of linear waterway	
Waterway terrain	Alluvial fan/stream	Alluvial fan formation is relatively old and stable
Mode of running water	Constant flow	All season water stream
Mode of debris-flow	Less	Sedimentation of debris-flow ~ sediment-flow
Nature of flow	Debris-flow	Gravel-type debris-flow stopping section

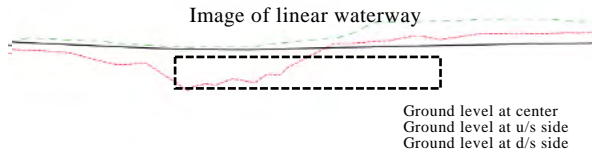
Floating debris	Non	Not observed roots and/or log of driftwood
Flood particle	Boulder	Max. boulder size 0.5m in July 2019 (approx. 10th from the largest particle size)
Bed condition at u/s side	Flat	Alluvial fan plain, 6% slope and developed by the quarry site
Bed condition at d/s side	Open channeled	6% slope and shallow stream with 36m width in July 2019
Linear waterway width		36 m width (widened by flood in July 2019)
Sediment		Less sedimentation at quarry site at u/s Crushing plant in operation with quarry site in u/s
Bearing stratum	Dense	Sediment: will be assumed N-value by geotechnical survey at site for open foundation
Land use	u/s side	Houses, public use, cultivated land Operation of quarry and crushing plant at U/S of D/S side
Social aspect		Road level shall be lowered to reduce social impact

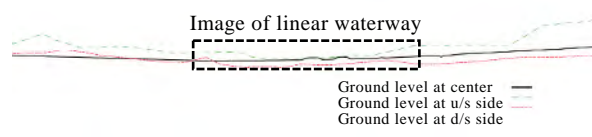
Table 3-9 Field Investigation for Bhyakure Causeway

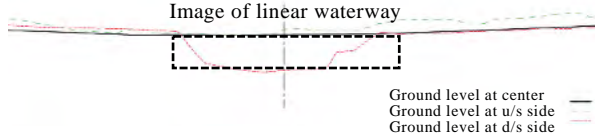
Subject	Condition	Description
Photo	Site Visit after flooding	
Cross section	by Topographical survey Image of linear waterway	
Waterway terrain	Alluvial fan (widely flat)	Alluvial fan formation is relatively old and stable
Mode of running water	Constant flow	All season water stream
Mode of debris-flow	Less	Sedimentation of debris-flow ~ sediment-flow
Nature of flow	Debris-flow	Gravel-type debris-flow stopping section
Floating debris	Non	Not observed roots and/or log of driftwood
Flood particle	Boulder	Max. boulder size 1.0m in July 2019 (approx. 10th from the largest particle size)
Bed condition at u/s side	Flat	Alluvial fan plain, 2% slope and developed by the quarry site
Bed condition at d/s side	Open channeled	4% slope and channelized by scouring with flood-flow with 43m width and 8m drop height
Linear waterway width	43m	43m width (widened by flood in July 2019)
Sediment		Less sedimentation at quarry site at u/s Crushing plant had demobilized
Bearing stratum	Very dense	Sediment: shall be checked N-value by geotechnical survey at site for open foundation
Land use	u/s side	Village, public use, cultivated land, Under expanding play ground Crushing plant had already demobilized
Social aspect		Road level

Source: JICA Expert Team

## 4 Hydrological Analysis for Bridge Waterway

### 4.1 Return Period of Rainfall for Estimation of Peak Flood Discharge

All permanent bridges shall be designed for a discharge of 100-years return period. For the calculation of design discharge empirical formulas especially developed for other catchments shall not be used stipulated in 3.2 Design Discharge, Nepal Bridges Standards - 2067 (2010), DOR.

Therefore, the peak flood discharge, which is the basic condition for determining the scale and size of the waterway crossing structure, is based on the observation data of the Nepalthok Rainfall Station (CH. 110 + 000 near the Sindhuli Road) near the target points located between CH. 111+400 to CH. 119+700. The peak flood discharges in the tributaries are estimated using Rational method. For this, at first, time of concentration of flow in rivers and then basin rainfall intensities are determined.

### 4.2 Estimation of Rainfall Intensity for Time of Concentration Duration

Further, the monthly rainfalls records of 1980-2017 of Nepalthok station, where the closest station of the project sites is analyzed. The highest value of average monthly rainfall of 245 mm is found in July. The lowest value of average monthly rainfall of 4.0 mm is found in November. The average annual rainfall is 855 mm (Table 4-1 & Figure 4-1).

Table 4-1 Monthly Rainfall of Nepalthok

Year	Monthly Rainfall (mm)												Annual Rainfall (mm)
	Jan	Feb	Mar	Apr	May	Jun	Jul	Aug	Sep	Oct	Nov	Dec	
1980	11.5	9.6	13.0	6.2	104.2	167.0	136.8	82.6	103.7	12.3	0.0	0.3	647
1981	19.0	0.0	8.3	36.8	163.6	114.5	141.5	286.9	245.5	0.0	0.0	0.0	1016
1982	11.0	35.5	16.0	19.2	29.0	66.2	204.7	118.7	150.4	0.0	14.2	0.3	665
1983	25.0	0.0	15.5	106.6	109.0	38.8	248.4	122.4	73.0	115.9	0.0	13.4	868
1984	9.4	18.5	0.0	48.0	58.3	208.4	342.7	105.5	439.3	5.1	0.0	11.2	1246
1985	5.2	0.0	0.0	16.4	163.5	62.9	313.0	169.7	335.9	169.8	0.0	84.2	1321
1986	0.0	13.0	0.0	43.3	51.9	170.7	204.7	171.5	201.5	30.0	0.0	44.8	931
1987	0.0	23.1	30.9	64.1	5.1	121.6	551.3	140.8	121.1	234.5	0.0	10.0	1303
1988	0.0	9.5	59.2	17.0	88.3	131.9	213.4	226.5	70.5	9.3	0.2	70.2	896
1989	43.5	10.2	14.0	6.1	107.9	43.1	256.5	43.5	156.1	5.2	0.0	0.0	686
1990	0.0	36.2	17.4	28.7	132.4	64.0	305.2	287.0	92.7	75.4	0.0	0.0	1039
1991	34.3	9.3	52.2	46.6	79.4	100.1	26.9	57.2	48.5	0.0	1.3	15.1	471
1992	2.2	9.2	0.0	15.1	53.5	43.4	197.7	97.4	38.3	34.6	19.2	0.0	511
1993	18.2	18.1	35.2	99.2	38.5	110.6	286.8	238.2	42.8	0.0	0.0	0.0	888
1994	36.4	18.1	14.4	42.7	30.3	210.5	111.4	142.2	112.8	0.0	0.0	0.0	719
1995	0.2	25.8	9.4	0.0	70.1	269.4	132.7	167.8	61.0	2.4	97.4	16.2	852
1996	64.9	3.6	25.0	5.3	43.8	274.2	284.5	242.0	55.1	42.2	0.0	0.0	1041
1997	22.6	0.0	12.4	66.1	44.5	126.5	253.1	203.1	40.6	18.4	0.3	123.5	911
1998	0.0	11.6	91.0	64.8	24.2	126.7	423.2	207.3	134.3	8.5	17.5	0.0	1109
1999	0.4	0.0	0.0	3.1	71.6	289.8	366.2	256.1	130.0	184.5	0.0	0.0	1302
2000	0.0	2.1	0.0	93.8	53.7	82.2	265.6	194.3	36.4	0.0	0.0	0.4	729
2001	0.0	12.0	19.1	14.5	104.7	128.3	213.6	110.5	99.0	50.2	0.0	0.0	752
2002	28.3	14.0	40.4	64.3	157.8	32.3	622.4	211.8	97.5	17.1	0.0	16.0	1302
2003	0.0	55.3	18.0	3.4	52.3	96.2	397.8	106.9	5.1	0.0	0.0	42.5	778
2004	7.3	0.0	3.0	40.0	136.3	91.7	556.7	34.2	37.1	0.0	0.0	0.0	906
2005	3.5	0.0	27.7	30.4	27.6	128.7	132.8	285.6	185.3	43.4	0.0	0.0	865
2006	0.0	0.0	38.7	60.3	86.7	148.5	125.1	92.6	182.9	0.0	0.0	0.0	735
2007	0.0	94.9	14.8	47.5	31.2	154.3	304.6	200.0	292.0	55.0	0.0	0.0	1194
2008	0.0	0.0	10.1	32.4	41.0	98.0	116.5	147.0	43.5	0.0	0.0	0.0	489
2009	0.0	0.0	23.3	4.1	131.7	38.7	192.9	158.7	102.3	39.2	0.0	3.2	694
2010	0.0	9.3	0.0	19.5	64.9	14.1	116.8	196.8	72.8	28.8	0.0	0.0	523
2011	2.1	35.1	0.0	23.1	106.6	152.3	198.8	114.1	161.2	0.0	0.0	0.0	793
2012	5.1	22.4	0.0	67.8	42.0	118.2	215.5	160.4	124.7	0.0	0.0	0.0	756
2013	6.7	33.6	13.0	10.0	47.6	186.6	217.5	80.1	131.1	172.6	0.0	0.0	899
2014	1.5	10.1	35.5	-	-	-	199.9	239.3	34.1	31.6	0.0	9.5	562
2015	6.1	31.2	84.1	65.9	23.0	118.6	138.9	151.9	38.9	11.9	0.0	0.0	671

2016	1.7	9.9	16.0	2.5	95.6	81.7	210.1	94.6	159.8	50.9	0.0	0.0	723
2017	36.2	0.0	71.2	64.6	109.6	84.2	82.0	141.7	105.3	3.5	0.0	0.0	698
Mean	10.6	15.3	21.8	36.3	73.2	118.3	245.0	160.2	120.1	38.2	4.0	12.1	855

Source: Rainfall data from Meteorological Survey Center, Kathmandu

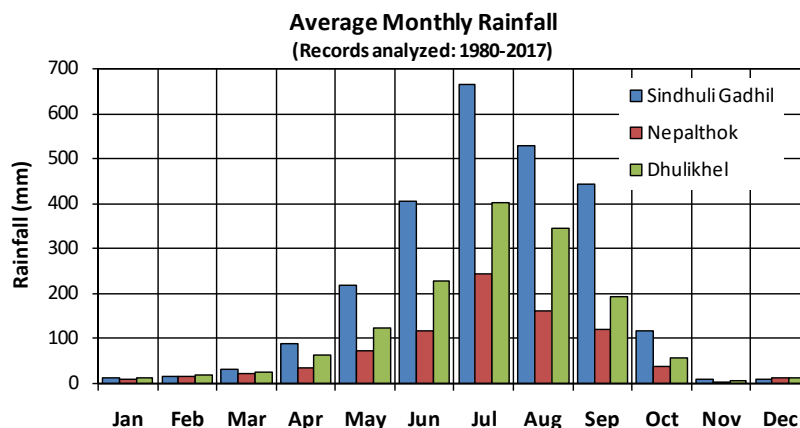

Figure 4-1 Average Monthly Rainfalls in Project Area

### 4.3 Frequency Analysis of Annual Maximum Daily Rainfall

The frequencies of annual maximum daily rainfalls of the stations along the Sindhuli road and Kathmandu Airport station were analyzed. The most commonly used Lognormal (LN) distribution function was employed for frequency analysis of the annual maximum daily rainfall of the stations. The relation of cumulative distribution function (cdf) of Lognormal (LN) distribution is as presented below. The detail of the calculation is referred to the Annex-5.

$$F(x) = \Phi \left[ \frac{\ln(x) - \mu}{\sigma} \right] \text{ --- Log-normal distribution function}$$

Where,

- $F(x)$  = Cumulative distribution function (cdf)
- $\Phi$  = cdf of standard normal distribution
- $x$  = Variable
- $\mu, \sigma$  = Normal parameters

The time series of annual maximum daily rainfalls of Nepalthok station nearest station of the project sites are presented in Table 4-2 & Figure 4-2.

Table 4-2 Annual Maximum Daily Rainfall of Nepalthok

Year	Annual Max. Daily Rainfall (mm)	Year	Annual Max. Daily Rainfall (mm)	Year	Annual Max. Daily Rainfall (mm)
1948	74.2	1972	105.5	1996	84.2
1949	52.7	1973	122.0	1997	84
1950	69.6	1974	100.2	1998	77.1
1951	63.5	1975	80.2	1999	103.3
1952	101.6	1976	50.4	2000	82.2
1953	40.6	1977	40.2	2001	60.3
1954	76.4	1978	94.4	2002	139.2
1955	114.3	1979	123.4	2003	80.1
1956	117.3	1980	80.4	2004	126.2
1957	55.9	1981	215	2005	101.0
1958	50.8	1982	97.3	2006	87.2
1959	320.4	1983	64.4	2007	79.1
1960	260.0	1984	136.2	2008	41.0
1961	120.8	1985	99.2	2009	50.2
1962	83.0	1986	120.3	2010	42.3
1963	81.3	1987	138.2	2011	82.4
1964	70.0	1988	72	2012	75.2

1965	60.0	1989	73.2	2013	98.2
1966	65.0	1990	85.3	2014	45.3
1967	32.4	1991	32.2	2015	49.0
1968	125.0	1992	53	2016	54.1
1969	50.4	1993	100	2017	62.3
1970	100.2	1994	85.1	-	
1971	175.4	1995	82	-	

Source: Rainfall data from Meteorological Survey Center, Kathmandu

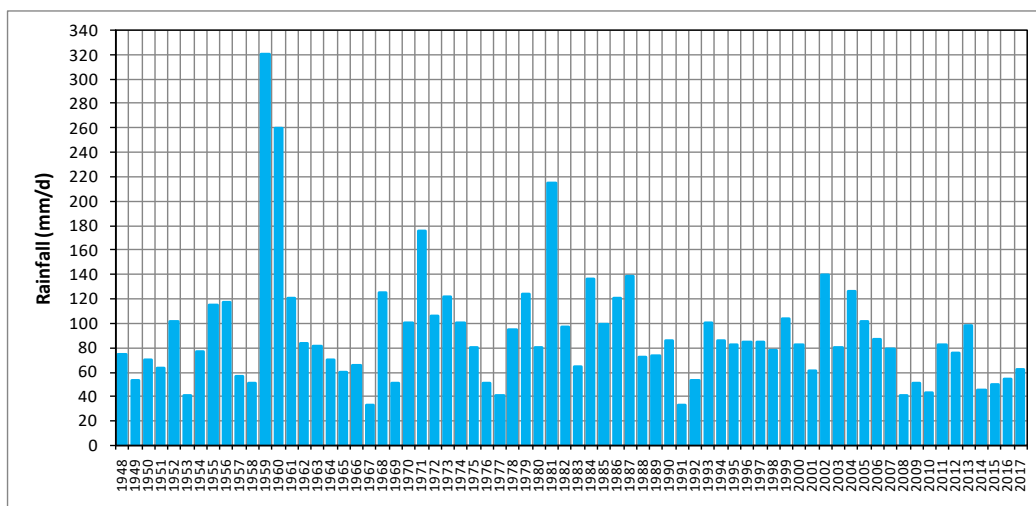

Source: Rainfall data from Meteorological Survey Center, Kathmandu

Figure 4-2 Annual Maximum Daily Rainfall of Nepalthok

The frequency of annual maximum daily rainfalls of 1948-2017 was analyzed employing the Log-normal (LN) distribution function in Figure 4-3. The curve fitting of the distribution function shows the design rainfalls of 2, 3, 5, 10, 25, 50 and 100-year return periods are 81, 99, 118, 144, 177, 203 and 229 mm, respectively in Table 4-3.

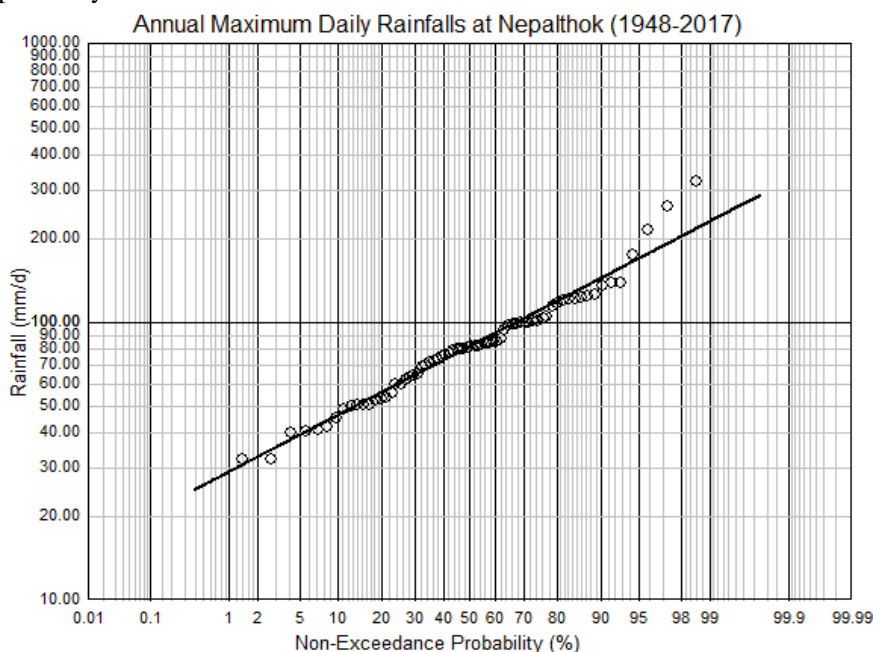

Figure 4-3 Lognormal Distribution Fitting of Maximum Rainfall of Nepalthok

Table 4-3 Design Daily Rainfall of Nepalthok

Return period (year)	2	3	5	10	25	50	100
Rainfall (mm)	81	99	118	144	177	203	229

Source: Annex-5 Hydrology & Hydraulic Study Report, SROM-2

### 4.4 Isohyets of Design Daily Rainfalls of the Project Area

The isohyets of 25, 50 and 100-year daily rainfall of the project area has been developed analyzing the frequency of the time series of annual maximum daily rainfalls of 26 stations located in and around the project area. The isohyets show there are two heavy rainfall pockets areas along the Sindhuli road. The first heavy rainfall pocket area is Sindhuli Gadhi along Sindhuli Road which has 100-year daily rainfall of 487 mm in Table 4-4. Similarly, Pachuwarghat and Dolalghat are identified as the lowest rainfall pocket areas with 100-year daily rainfall of 135 mm and 141 mm, respectively. The developed isohyets of 25, 50 and 100-year daily rainfall of the project area provide ideas on rainfall distributions in the project area in *Annex-5 Hydrological and Hydraulic Study Report*.

Table 4-4 Design Daily Rainfall of Stations along the Sindhuli Road

S N	Station no.	Location of station	District	Latitude (N)	Longitude (E)	Elevation m	25-year design daily rainfall mm	50-year design daily rainfall mm	100-year design daily rainfall mm	Remarks
1	1030	KTM Airport	Kathmandu	27°42'	85°22'	1,337	123	132	141	
2	1024	Dhulikhel	Kavrepalanchowk	27°37'	85°33'	1,552	153	169	185	
3	1023	Dolalghat	Kavrepalanchowk	27°38'	85°43'	710	118	129	141	
4	1028	Pachuwarghat	Kavrepalanchowk	27°34'	85°45'	633	112	123	135	
5	1115	Nepalthok	Sindhuli	27°27'	85°49'	1,098	177	203	229	Applied
6	1107	Sindhuli Gadhi	Sindhuli	27°17'	85°58'	1,463	366	426	487	
7	1110	Tulsi	Dhanusa	27°02'	85°55'	457	265	298	331	

Source: Annex-5 Hydrology & Hydraulic Study Report, SROM-2

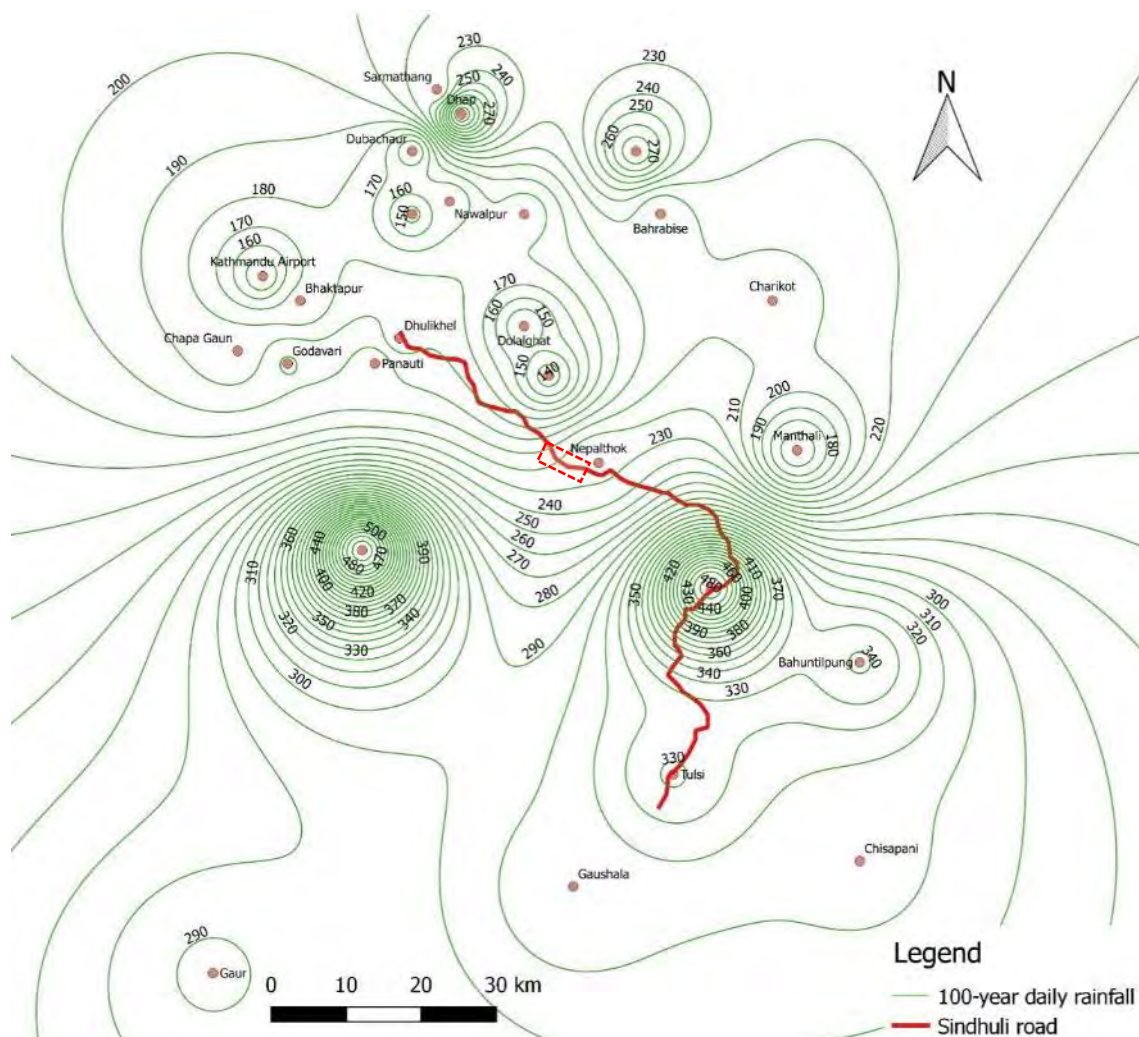

Figure 4-4 Isohyets of 100-year Daily Rainfall of the Project Area

#### 4.5 Frequency Analysis of Short Duration Rainfall

The short duration rainfall depths are necessary for the peak flood discharge estimation in tributaries. For this purpose, the design short duration rainfall depths of Kathmandu (KTM) Airport station are used as reference. The frequency analyses of short duration rainfall depths of 10-min and 60-min and 24-hour rainfall of Kathmandu Airport cited in the report is presented in the Table 4-5 and *Annex-5*.

Table 4-5 Design Short Duration Rainfall of Kathmandu Airport

Return period (year)	10-min		60-min		24-hour I <sub>24-hour</sub> mm
	I <sub>10-min</sub> mm	I <sub>10-min</sub> /I <sub>24-hour</sub> (Fraction)	I <sub>60-min</sub> mm	I <sub>60-min</sub> /I <sub>24-hour</sub> (Fraction)	
2	12	0.21	31	0.56	56
3	14	0.23	35	0.55	62
5	16	0.24	38	0.55	69
10	19	0.25	43	0.55	78
25	23	0.25	48	0.54	89
50	25	0.26	52	0.54	97

Source: Annex-5 Hydrology & Hydraulic Study Report, SROM-2

$$i_t = i_{24-hour} \cdot \left( \frac{I_t}{I_{24-hour}} \right)$$

Where,

- $i_t$  = Rainfall amount of 't' duration at Station to be considered (mm)
- $i_{24-hour}$  = 24-hour rainfall amount at Station to be considered (mm)
- $I_t$  = Rainfall amount of 't' duration at Kathmandu Airport (mm)
- $I_{24-hour}$  = 24-hour rainfall amount at Kathmandu Airport (mm)

Short duration rainfall depths of various return periods of station to be considered were estimated using the above equation. Based on the estimated short duration rainfalls of various return periods, the IDF-Curves of station to be considered were developed. The relation used for developing the IDF-Curve is as presented below.

$$I = \frac{a}{(t^n + b)}$$

Where,

- $I$  = Rainfall intensity (mm/hr)
- $t$  = Duration (minute)
- $a, b, n$  = Constants

The short duration rainfall depth of Nepalthok station in Table 4-6 is estimated being based on the short duration rainfall depth of various durations of Kathmandu Airport station. Values of the constants of rainfall IDF-Curve determined for this station are presented in Table 4-7; and design rainfall intensity of various durations of this station are presented in Table 4-8. The developed rainfall IDF-Curve of this station is presented in Figure 4-5. The 50-year rainfall intensity of 5, 10, 15, 30, 45, 60- and 120-minutes durations of this station are 399, 318, 266, 179, 136, 110 and 63 mm/hr, respectively.

Table 4-6 Design Rainfall Depth of Various Durations of Nepalthok

Return period (year)	Rainfall depth (mm)				
	60-min	30-min	15-min	10-min	5-min
2	45	34	23	17	10
3	54	43	30	23	14
5	65	52	37	28	17
10	79	64	46	36	22
25	96	78	57	44	27
50	110	90	67	53	33
100	121	101	76	62	39

Table 4-7 IDF-Curve Constants of Nepalthok

Return period (year)	Constants		
	n	a	b
2		3345.26	23.61
3	0.955	3702.60	17.82
5	0.955	4294.74	15.92
10	0.955	5126.26	14.58
25	0.955	6117.02	13.87
50	0.955	6859.50	12.53
100	0.955	7410.24	11.12

Table 4-8 Design Rainfall Intensity of Various Durations of Nepalthok

Duration	Return period (year)						
	2	3	5	10	25	50	100
5-min Rainfall Intensity (mm/hr)	118	165	209	267	330	399	470
10-min Rainfall Intensity (mm/hr)	103	138	172	217	267	318	368
15-min Rainfall Intensity (mm/hr)	91	119	147	184	225	266	304
30-min Rainfall Intensity (mm/hr)	68	85	103	127	154	179	201
45-min Rainfall Intensity (mm/hr)	54	66	80	98	118	136	151
60-min Rainfall Intensity (mm/hr)	46	55	65	80	96	110	121
120-min Rainfall Intensity (mm/hr)	28	32	38	46	55	63	69

**IDF-Curves of Nepalthok**

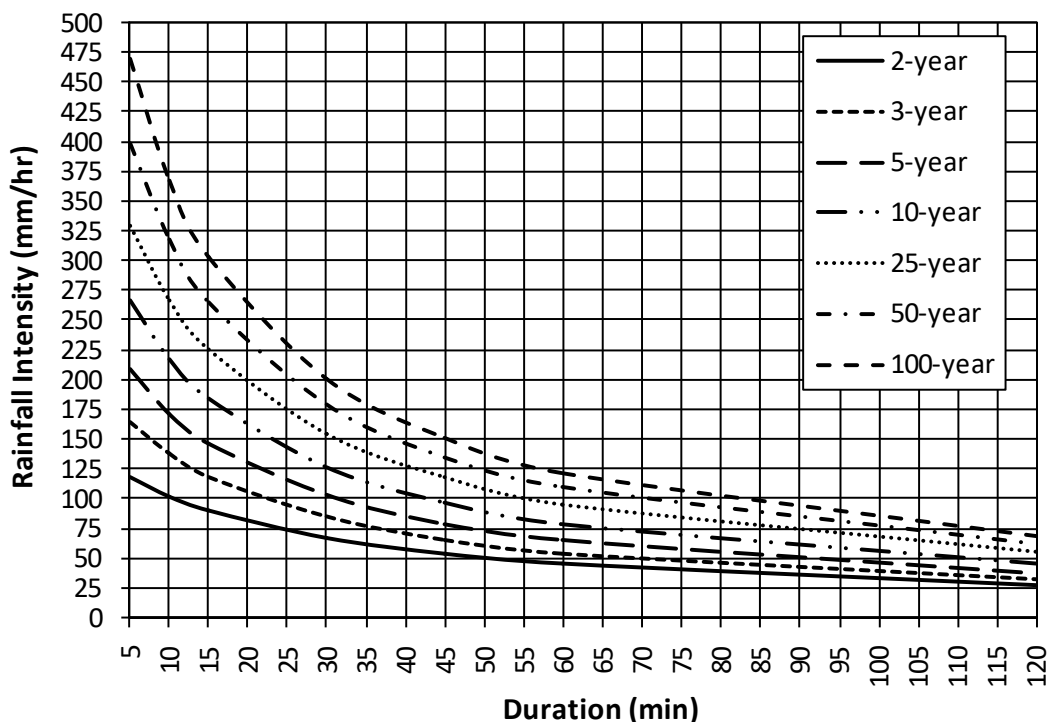

Figure 4-5 The IDF-Curve of Nepalthok

**4.6 Estimation of Peak Flood Discharge in the Tributaries**

The peak flood discharges in the rivers are estimated using Rational method. For this, at first, time of concentration of flow in rivers and then basin rainfall intensities are determined.

**4.6.1 Catchment Area of Tributaries**

The catchment areas of the tributaries are presented in Table 4-9 and the catchment map of the tributaries is presented in Figure 4-6.

Table 4-9 Catchment Area of Tributaries

SN.	Tributary	Catchment Area
1	Ghyampe river	17.333 km <sup>2</sup>
2	Barkhe river	2.045 km <sup>2</sup>
3	Mamti river	17.173 km <sup>2</sup>
4	Bhyakure river	22.359 km <sup>2</sup>
5	Kaldhunga river	0.599 km <sup>2</sup>

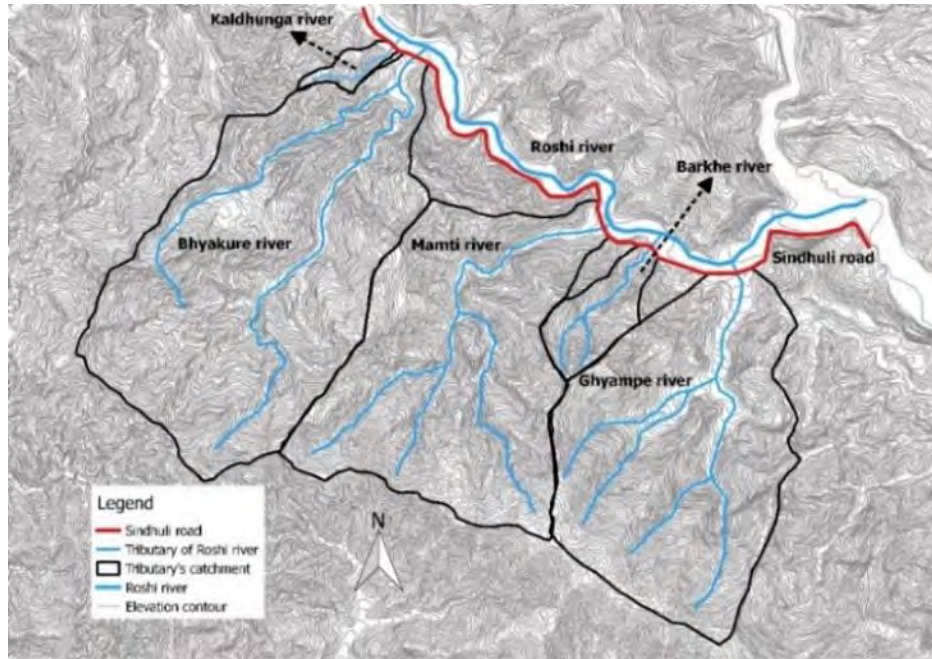

Figure 4-6 Catchment Area Map

#### 4.6.2 Estimation of Time of Concentration Flow

The time of concentration flow is determined considering the travel time of overland flow at upstream part of the catchment from boundary to inlet of flow concentration channel along with travel time of flow from inlet to outlet of the channel.

##### (1) Travel Time of Overland Flow ( $T_1$ )

For estimating the time of concentration ( $T_c$ ) of flow, the travel time of overland flow from catchment boundary to inlet of flow concentration channel ( $T_1$ ) at the upstream part of the catchment is estimated using Kerby's equation. The retardance coefficients for different ground cover are presented in Table 4-10. The parameters used for estimation of travel time of overland flow and the estimated travel time are presented in Table 4-11.

$$T_1 = 1.445 * \left( \frac{n.L}{S^{0.5}} \right)^{0.467}$$

Where,

- $T_1$  = Travel time of overland flow (min)
- $n$  = Kerby's retardance coefficient of roughness (-)
- $L$  = Travel length of overland flow (m)
- $S$  = Slope of ground surface (m/m)

Table 4-10 Kerby's Retardance Coefficient

Ground Cover	Kerby's Retardance Coefficient (n)
Timberland with deep forest litter or dense grass	0.8
Deciduous timberland	0.6
Pasture or average grass	0.4
Poor grass cultivated row crops of moderately rough bare soil	0.2
Smooth, packed bare soil	0.1
Smooth, impervious surface	0.02

Table 4-11 Parameters for Estimation of Travel Time of Overland Flow

Description	Tributaries				
	Ghyampe	Barkhe	Mamti	Bhyakure	Kaldhunga
Elevation at catchment's boundary (EL: m)	2060	1660	2080	2380	1240
Elevation at inlet of flow concentration channel (EL: m)	1840	1540	1940	2020	1140
Travel length of overland flow (L: m)	440	200	400	500	200
Slope of ground surface (S: m/m)	0.500	0.600	0.350	0.720	0.500
Kerby's roughness coefficient (n: -)	0.4	0.4	0.4	0.4	0.4
Travel time of overland flow (T <sub>1</sub> : min)	19.00	12.60	19.75	18.53	13.15

Source: JICA Expert Team

## (2) Travel Time of Flow in Channel (T<sub>2</sub>)

After concentrating the overland flow at the inlet of channel, the runoff starts to flow in the channel. The flow travel time of runoff from inlet to outlet of channel (T<sub>2</sub>) is estimated by the relation developed by Soil Conservation Services (SCS). Curve number (CN) was decided based on the land cover type, hydrological conditions and soil groups. The CN of 60 was considered due to having soil of group B and land cover type woods with fair hydrological conditions in the catchment. Because land has moderate infiltration rates and soils chiefly consist of moderately fine to moderately coarse textured soils. The definition of different hydrologic soil group is given in Table 4-12 and curve numbers proposed for different type of woods cover is presented in Table 4-13.

Table 4-12 Hydrologic Soil Groups Defined by Soil Conservation Services

Hydrologic Soil Group	Definition
A	Soils have low runoff potential and high infiltration rate, and they consist chiefly sand or gravel particles.
B	Soils have moderate infiltration rate, and they consist chiefly moderately fine to moderately coarse textured soils.
C	Soils have low infiltration rate, and they consist chiefly soils with moderately fine to fine texture.
D	Soils have high runoff potential and very low infiltration rate, and they consist chiefly clay soils.

Source: Urban hydrology for small watersheds, United States Department of Agriculture, Natural Resources Conservation Services, Conservation Engineering Division, Technical Release 55, June 1986, Appendix A.

Table 4-13 Proposed Curve Numbers (CN) by SCS

Cover Type	Hydrologic Condition	Curve Numbers for Hydrologic Soil Group			
		A	B	C	D
Woods	Poor	45	66	77	83
	Fair	36	60	73	79
	Good	30	55	70	77

Poor: Forest litter, small tree, and brush are destroyed by heavy grazing or regular burning

Fair: Woods are grazed but not burned and some forest litter covers the soil

Good: Woods are protected from grazing and litter and brush adequately cover the soil

Source: Urban hydrology for small watersheds, United States Department of Agriculture, Natural Resources Conservation Services, Conservation Engineering Division, Technical Release 55, June 1986, page 2-7.

The relation developed by SCS for estimation of travel time of flow over the channel in the catchment (T<sub>2</sub>) is as presented below.

$$T_2 = 0.14 * C * L^{0.66} \left( \frac{CN}{200-CN} \right)^{-0.55} G^{-0.3}$$

Where,

- $T_2$  = Travel time of flow in channel (from inlet to outlet of flow concentration channel) (min)  
 $C$  = Channelization factor for runoff velocity (0.77)  
 $L$  = Travel length of flow (km)  
 $CN$  = Curve Number proposed by SCS for landscape  
 $G$  = Slope of landscape (m/m)

The parameters used for the estimation of travel time of flow in channel and the estimated travel time are presented in Table 4-14.

Table 4-14 Parameters for Estimation of Travel Time of Channel Flow

Description	Tributaries				
	Ghyampe	Barkhe	Mamti	Bhyakure	Kaldhunga
Elevation at inlet of channel (EL: m)	1840	1540	1940	2020	1140
Elevation at outlet of channel (EL: m)	585	589	600	688	687
Travel length of flow (L: km)	5.804	2.730	7.204	8.360	1.370
Channelization factor for runoff velocity I	0.77	0.77	0.77	0.77	0.77
Curve Number proposed by SCS for landscape (CN: -)	60	60	60	60	60
Slope of landscape (G: m/m)	0.216	0.348	0.186	0.159	0.331
Travel time of flow in channel ( $T_2$ : min)	52.09	27.44	62.85	72.63	17.68

Source: JICA Expert Team

### (3) Time of Concentration

Finally, the time of concentration of runoff is estimated with summing up the overland flow travel time and channel flow travel time of the runoff.

$$T_C = T_1 + T_2$$

Where,

- $T_C$  = Time of concentration of flow (min)  
 $T_1$  = Travel time of overland flow (min)  
 $T_2$  = Travel time of flow in concentration channel (min)

The time of concentration of flow estimated in the different tributaries are presented in Table 4-15.

Table 4-15 Time of Concentration of Flow in the Tributaries

Description	Tributaries				
	Ghyampe	Barkhe	Mamti	Bhyakure	Kaldhunga
Time of concentration of flow ( $T_C$ : min)	71.09	40.04	82.60	91.16	30.83

Source: JICA Expert Team

### 4.6.3 Estimation of Rainfall Intensity for Time of Concentration Duration

The rainfall intensities for the time of concentration of flow in tributaries, where damaged causeways have to be rehabilitated, were estimated for 100-year return periods and 10, 25, 50-year for reference, based on the short duration rainfall IDF-Curve developed for Nepalthok station where nearest station of the sites.

The estimated rainfall intensities of 10-year return period for the duration time of concentration of flow in tributaries are presented in Table 4-16.

Table 4-16 Rainfall Intensity for Time of Concentration Duration (10-year Return Period)

SN.	Tributary	$T_C$ -Time of Concentration (min)	Constants of Rainfall IDF-Curve of Nepalthok Station for 10-year Return Period			$I_{TC}$ -Rainfall Intensity for Time of Concentration Duration (mm/hr)
			n	a	b	
1	Ghyampe	71.09	0.955	5126.26	14.58	69.98
2	Barkhe	40.04				105.71
3	Mamti	82.60				62.29
4	Bhyakure	91.16				57.61
5	Kaldhunga	30.83				125.02

Source: JICA Expert Team

The estimated rainfall intensities of 25-year return period for the duration time of concentration of flow in tributaries are presented in Table 4-17 below.

Table 4-17 Rainfall Intensity for Time of Concentration Duration (25-year Return Period)

SN.	Tributary	T <sub>C</sub> -Time of Concentration (min)	Constants of Rainfall IDF-Curve of Nepalthok Station for 25-year Return Period			I <sub>TC</sub> -Rainfall Intensity for Time of Concentration Duration (mm/hr)
			n	a	b	
1	Ghyampe	71.09	0.955	6117.02	13.87	84.32
2	Barkhe	40.04				128.01
3	Mamti	82.60				74.97
4	Bhyakure	91.16				69.29
5	Kaldhunga	30.83				151.82

Source: JICA Expert Team

The estimated rainfall intensities of 50-year return period for the duration time of concentration of flow in tributaries are presented in Table 4-18 below.

Table 4-18 Rainfall Intensity for Time of Concentration Duration (50-year Return Period)

SN.	Tributary	T <sub>C</sub> -Time of Concentration (min)	Constants of Rainfall IDF-Curve of Nepalthok Station for 50-year Return Period			I <sub>TC</sub> -Rainfall Intensity for Time of Concentration Duration (mm/hr)
			n	a	b	
1	Ghyampe	71.09	0.955	6859.5	12.53	96.33
2	Barkhe	40.04				147.69
3	Mamti	82.60				85.48
4	Bhyakure	91.16				78.90
5	Kaldhunga	30.83				176.10

Source: JICA Expert Team

The estimated rainfall intensities of 100-year return period for the duration time of concentration of flow in tributaries are presented in Table 4-19 below.

Table 4-19 Rainfall Intensity for Time of Concentration Duration (100-year Return Period)

SN.	Tributary	T <sub>C</sub> -Time of Concentration (min)	Constants of Rainfall IDF-Curve of Nepalthok Station for 100-year Return Period			I <sub>TC</sub> -Rainfall Intensity for Time of Concentration Duration (mm/hr)
			n	a	b	
1	Ghyampe	71.09	0.955	7410.24	11.12	106.17
2	Barkhe	40.04				164.55
3	Mamti	82.60				93.99
4	Bhyakure	91.16				86.64
5	Kaldhunga	30.83				197.38

Source: JICA Expert Team

#### 4.6.4 Determining Peak Flood Discharge

The peak flood discharge in the tributary is estimated using Rational method being based on runoff coefficient, catchment area and design rainfall intensity for time of concentration duration. The peak flood discharge in the tributaries is estimated using the relation presented below.

$$Q_P = \frac{P \cdot I_{TC} \cdot A}{3.6} \text{ ----- Rational method}$$

Where,

$Q_P$  = Peak flood discharge ( $m^3/s$ )

$P$  = Runoff coefficient (0.8 at boulder and gravel)

$I_{TC}$  = Design rainfall intensity for time of concentration duration (mm/hr)

$A$  = Catchment area ( $km^2$ )

IRC: SP13-2004, Guidelines for the Design of Small Bridges and Culverts, guidance of the runoff coefficient (P) are shown in the following Table. Runoff coefficient (P) as 0.8 for "rock" for riverbed boulder and gravel at three project rivers are adopted.

In case of Japan, Road Earthworks and Drainage Design Guideline of Japan Road Association recommends the values of runoff coefficient (P) as 0.8 for designing of cross drains and 0.4 for designing of side ditches along the roads for steep mountainous areas considering the importance of structures as shown in Table 4-20 below.

Table 4-20 Guidance of Runoff Coefficient P

Type of soil	Runoff coefficient
Steep, bare rock and also city pavements	0.90
Rock, steep but wooded	0.80
Plateaus, lightly covered	0.70
Clayey soils, stiff and bare	0.60
Clayey soils, lightly covered	0.50
Loam, lightly cultivated or covered	0.40
Loam, largely cultivated	0.30
Sandy soil, light growth	0.20
Sandy soil, covered, heavy bush	0.10

Source: IRC: SP13-2004, Table 4.1

The estimated peak flood discharge in the tributaries for various return periods are presented in Table 4-21 below.

Table 4-21 Estimated Peak Flood Discharge in Tributaries

S N	Tributary	P I	Catchment A km <sup>2</sup>	10-year Return Period		25-year Return Period		50-year Return Period		100-year Return Period	
				I <sub>TC</sub> mm/hr	Q <sub>P</sub> m <sup>3</sup> /s	I <sub>TC</sub> mm/hr	Q <sub>P</sub> m <sup>3</sup> /s	I <sub>TC</sub> mm/hr	Q <sub>P</sub> m <sup>3</sup> /s	I <sub>TC</sub> mm/hr	Q <sub>P</sub> m <sup>3</sup> /s
1	Ghyampe	0.8	17.333	69.98	269.53	84.32	324.77	96.33	371.04	106.17	408.93
2	Mamti	0.8	17.173	62.29	237.70	74.97	286.11	85.48	326.20	93.99	358.69
3	Bhyakure	0.8	22.359	57.61	286.23	69.29	344.30	78.90	392.04	86.64	430.50

Source: JICA Expert Team

4.6.5 Corollary, Calculation of Discharge by Broad Crested Method

(1) Verification of the Bhyakure Tributary on the 12<sup>th</sup> July 2019 Flood

Because of local scour on the downstream side of the road, Bhyakure and Ghyampe causeways have a free drop (fall) of about 8m. The flow along these tributaries can be assumed as free flow and the equation of broad crested fall can be applied for calculating the passing discharge. The definition sketch of Broad Crested fall is presented in Figure 4-7 below.

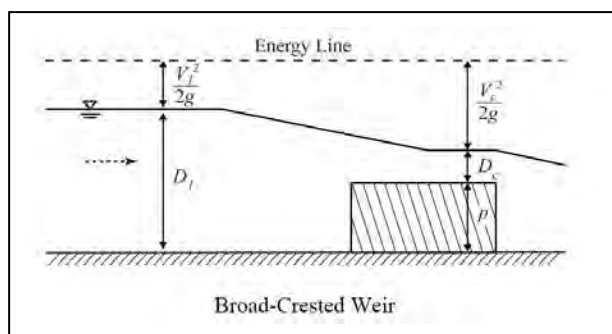

Figure 4-7 Definition Sketch of Broad Crested Weir

At the brink of fall of Broad Crested Weir (BCW) the flow becomes critical flow and hence the Froude's Number (Fr) becomes 1.0.

$$Fr = V_c / \sqrt{(g \times D_c)} = 1.0$$

$$\rightarrow V_c = \sqrt{(g \times D_c)} \dots\dots\dots (eq. 1)$$

On 12<sup>th</sup> July 2019 about 8:00 AM, the flood at Bhyakure Khola experienced highest flood and the real time video taken at that moment revealed that the height of flow at the brink of fall has been judged as equal to 0.7 m to 1.0 m. Average height can be judged as 0.85 m which is critical depth of flow,  $D_c$  as shown in the Figure 4-8 with image view raised up.



Figure 4-8 Real time video at peak flow Bhyakure on 12<sup>th</sup> July 2019

Considering the flow as critical flow (being over Broad Crest), the velocity is critical as per eq-1 above, equal to 2.89 m/s and hence  $Q = Ax V_c (0.85 \times 33 \times 2.89) = 81 \text{ m}^3/\text{s}$ .

From the record of Department of Hydrology and Meteorology, Government of Nepal, the Rainfall occurred at Nepalthok Station for the period has been shown in Figure 4-9 below.

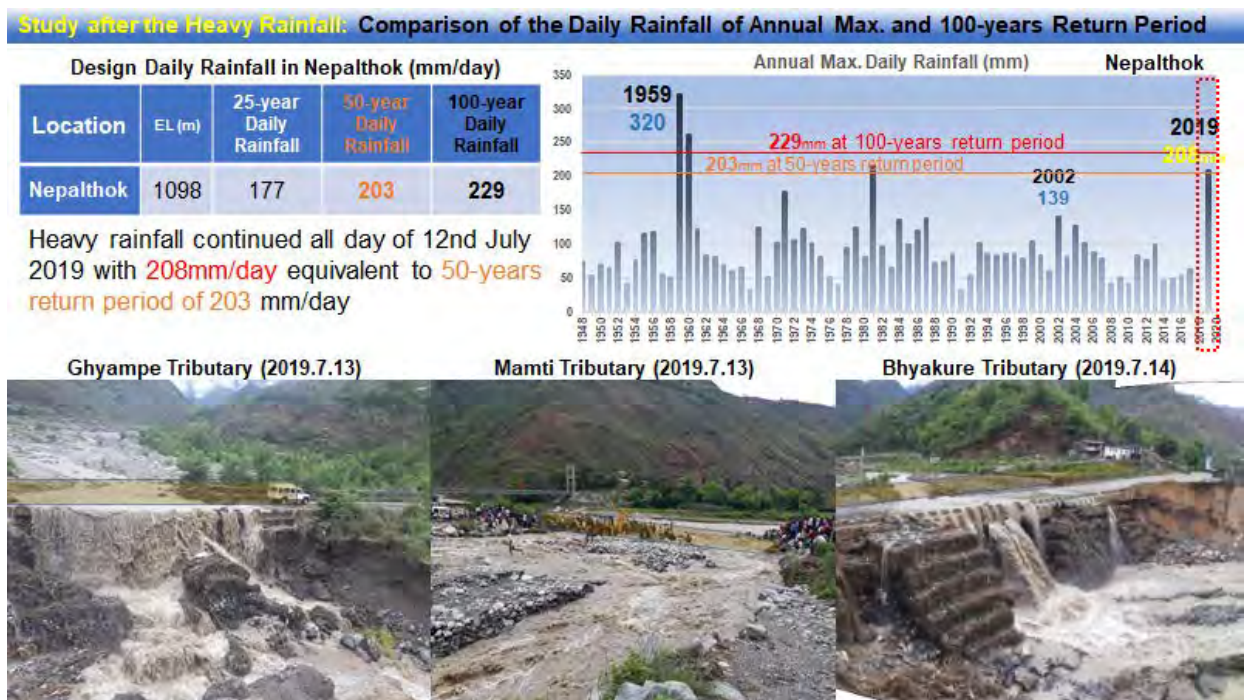

Figure 4-9 Rainfall Record of Nepalthok on 12<sup>th</sup> July 2019

A heavy rainfall continued all day of 12<sup>th</sup> July 2019 with 208mm/day which is equivalent to 50-years return period of 203mm/day. That means, the observed discharge at Bhyakure at peak flood time at 8:00 AM of 12<sup>th</sup> July 2019 is equal to 81 m<sup>3</sup>/s, which is nearly 50 years returned period discharge. Forecasting 100 years return period flow that from 50 years return period is about additional 10% more, which would be about 90 m<sup>3</sup>/s.

Conclusion of the verification, the peak flood discharge of Bhyakure Tributary calculated from rational method for 100 years return period is 430 m<sup>3</sup>/s is higher than observed value equivalent of 90 m<sup>3</sup>/s.

## 5 Hydraulics Study for Bridge Design

### 5.1 Estimation of Peak Flood Discharge in the Tributaries

A visit on candidate sites of the Pilot Project was made by JICA Expert Team member (Hydrology and Hydraulics) on 7<sup>th</sup> May 2019 for acquiring necessary information on existing status of the following causeways and conditions of river areas at upstream and downstream thereon.

#### Studied Causeway List

1. Ghyampe Causeway (Ch. 111+400 / Sta. 1+400 in Section IV)
2. Mamti Causeway (Ch. 113+900 / Sta. 3+900 in Section IV)
3. Bhyakure Causeway (Ch. 119+700 / Sta. 9+700 in Section IV)

The field visit report has been presented on *Annex-5*, Hydrological and Hydraulic Study Report.

#### 5.1.1 Hydraulics Analyses

JICA Expert Team member has studied on Hydraulic Analysis based on the secondary data available and some data collected by the JICA Expert Team by Topography Survey. The study has focused on the following topics.

### 5.2 Debris Flow Phenomenon

Debris flow occurs when water-laden masses of unconsolidated soil and fragmented rock move down mountainsides in response to gravitational attraction, funnel into stream channels, entrain objects in their paths, and form thick, muddy deposits on valley floors.

“The Study for the Design Criteria on the Transit Roads over Devastated Rivers, 1982, Technical Center for Sediment Control and Landslide, Japan” recommended a design policy for the bridges to be constructed at rivers with debris-flow. It classified debris-flows as shown in Table 5-1.

Table 5-1 Riverbed Gradient and Types of Debris Flow

Riverbed Gradient	Type of Flood
1/3 (35%) 20°	Debris-flow Occurrence section
	Debris-flow Passing section
1/4 (25%) 15°	Debris-flow Stopping, Sediment-flow Passing section
	Debris/Sediment-flow Stopping section
1/5 (17%) 10°	Sediment-flow Stopping section
	Flood-flow section
1/20 (5%) 3°	
1/60 (2%) 1°	

Source: The Study for the design criteria on the transit roads over devastated rivers, 1982, Technical Center

The characteristics of each type of debris-flow are described in Table 5-2.

Table 5-2 Deposit Characteristics of Debris Flow

Flow Type	Characteristics of Flow
Debris-flow	<ul style="list-style-type: none"> <li>• The flow is divided into large boulders at the tip of debris-flow and a subsequent part of sediment-flow</li> <li>• A maximum boulder dia. of 1.5 m or more exists</li> <li>• There is as welling in the center part of debris-flow</li> <li>• There are traces flowing down from the upstream and high straightness</li> <li>• Deposit relatively thick</li> <li>• There are 2 types of movement material as gravel or mud</li> </ul>
Sediment-flow	<ul style="list-style-type: none"> <li>• Traces of stratified structure carried by the flow can be seen</li> <li>• There is boulder with a maximum particle diameter of 0.5 to 1.0 m</li> </ul>

	around, while there are many fine-grained substances • Existence of sprayed deposits widely
Mud-flow	• Existing of layer upon layer deposit • Studding of boulder dia. 0.5-1.0m • Existing of fine materials • Existing of sprayed deposits widely
Flood-flow	• Relatively uniform grain size and flat deposition surface • Flowing and bedding structures are seen • The maximum gravel diameter is about 0.1 to 0.2 m • Widely dispersed and deposited, relatively thin

Source: The Study for the design criteria on the transit roads over devastated rivers, 1982, Technical Center

The nature of debris flow is governed by the gradient of riverbed based on the flow movement material of gravel or mud as mentioned in Table 5-3 below, same way riverbed grading and nature of debris-flow is presented in Figure 5-1 below.

Table 5-3 River Gradient and Nature of Debris Flow based on Material Type

Gravel Type Debris-flow		Mud Type Debris-flow		General flow material	Location of the project site
Bed gradient	Nature of Debris Flow	Bed gradient	Nature of Debris Flow		
steeper than 35% (>1/3)	Debris-flow occurrence section			Boulder larger than 1.5m	
35~25% (1/3~1/4)	Graval type Debris-flow passing section	35~25% (1/3~1/4)	Mud type Debris-flow passing section		
25~17% (1/4~1/5)	Graval type Debris-flow stopping and Sediment-flow passing section	25~17% (1/4~1/5)	Mud type Debris-flow stopping and Sediment-flow passing section	Boulder size 0.5~1m	
17~5% (1/5~1/20)	Graval type Debris-flow stopping and Sediment-flow passing section	17~3% (1/5~1/30)	Mud type Debris-flow stopping and Sediment-flow passing section	Scattering boulder size Max. 0.5~1m,	Ghyampe, Mamti and Bhyakure tributaries
5~2% (1/20~1/60)	Sediment-flow stopping section	3~2% (1/30~1/60)	Sediment-flow stopping section	mostly granular material	
2~1% (1/60~1/100)	Flood-flow section			Max. granular size 0.1~0.2m	

Source: The Study for the design criteria on the transit roads over devastated rivers, 1982, Technical Center

The tributaries that crossing the three bridges are flowing mainly gravel material and located where the normal gravel type debris-flow stopping and sediment-flow section overlap.

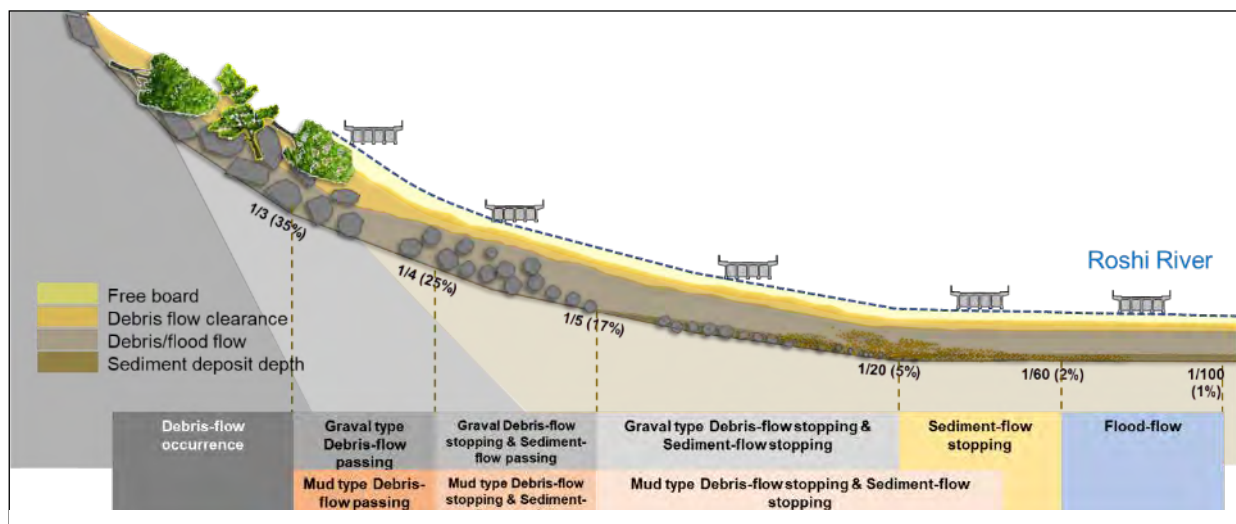

Figure 5-1 Riverbed Gradient and Nature of Debris-flow

The debris-flow is divided into a gravel type debris-flow and a mud type debris-flow, and the state of each flow is schematically represented as shown in the Figure 5-2. Gravel type debris-flow is occurred in mountain stream with rich sand, gravel and rock, on the other hands, mud type debris-flow occurred in stream mainly much contain silt, clay and fine particles. In the gravel type debris flow, boulders are concentrated at the tip of flow, but there is no boulder concentration at the tip of mud type debris-flow.

In addition, although the subsequent flow is in the state of flood flow, there are some disaster cases where some amount of gravel and debris is flowing out.

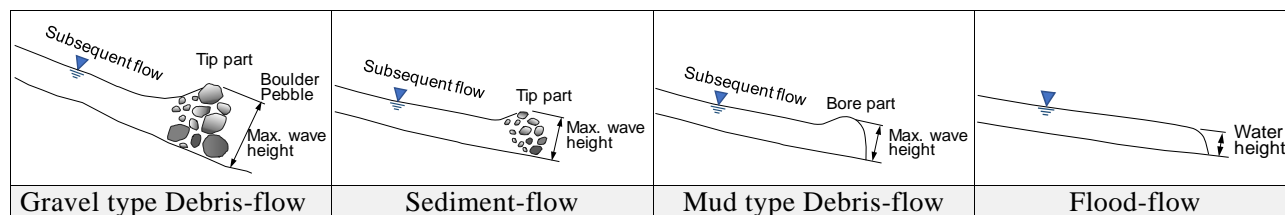

Figure 5-2 Pattern Diagram of Flow Type and Maximum Wave Height

### 5.3 Consideration of Pier Construction in Debris Flow with Boulders

The possibility of constructing bridge piers or wall at locations of debris flow is recommended as shown in Table 5-4.

Table 5-4 Bridge Pier Construction Possibility in River

Type of debris	Flowing point	Possibility of constructing pier in river
Gravel type Debris-flow	Flowing section	Not recommendable
	Stopping section	Not recommendable
Mud type Debris-flow	Flowing section	Not recommendable
	Stopping section	Practicable
Sediment-flow	Sediment flow section	Practicable

Source: The Study for the design criteria on the transit roads over devastated rivers, 1982, Technical Center

The reason why it is inappropriate to install a pier in the debris flow section is as follows: i) debris-flow has great destructive power, ii) it is not possible to set conditions when several large boulders contained in the debris-flow collide with the structure (pier) at the same time.

The main reason for those remarked as “Not recommendable” is the degree of difficulty in estimating the loads for the pier due to debris-flow. And it is not possible to set conditions when several large boulders contained in the debris-flow collide with the structure (pier) at the same time.

However, even if the normal debris-flow is in the stopping flow section at typical riverbed gradient being 17%~5%, if the bridge is raised to avoid damage for pier due to the debris flow and flow-down boulders (for example, it is necessary to raise it by 2 m or more considering the long span superstructure without pier), it will be used as a living road in the village. It may not be possible to rub against existing roads. In such a case, even if the debris flow section, it is considered to give priority to avoiding adverse effects on local life and social impact, and to use RC continuous slabs with inner walls or short span bridges with pier(s) to keep the elevation of the access road.

In addition, in recent years, if the size of boulders accompanying debris-flow is about 0.5 m dia. (representative size of boulders is estimated as the 10th largest diameter around the site, there will be no obstacles to the piers from the performance on the Sindhuli Road.

Based on above consideration at normal debris-flow section, the following modified bridge pier construction possibility proposed in Table 5-5.

Table 5-5 Bridge Pier Construction Possibility in River (Modified Version)

Type of flow	Crossing section	Typical riverbed gradient	Typical normal boulder size	Possibility of constructing pier in river
Gravel type Debris-flow	Occurrence section	>35% (>1/3)	Boulder larger than 1.5m (Max. 10m)	Not recommendable
	Passing section	35~25% (1/3~1/4)		Not recommendable
	Stopping section	25~17% (1/4~1/5)	Boulder size 0.5~1m	Not recommendable
Mud type Debris-flow	Passing section	35~25% (1/3~1/4)	Less boulder	Practicable
	Stopping section	25~17% (1/4~1/5)		Practicable
Normal Debris-flow	Stopping section	17~5% (1/5~1/20)	Scattering boulder size Max. 0.5~1m, mostly granular material	Practicable: according to some conditions
Sediment-flow	Sediment flow	5~2% (1/20~1/60)		Practicable
Flood-flow	Flood flow	2%~ (1/60~)	Max. granular size 0.1~0.2m	Practicable

Source: The Study for the design criteria on the transit roads over devastated rivers, 1982, Technical Center

If the debris flow is in a stopping section, we would like to consider that it is possible to install a bridge pier in the river or channel so as to meet the following three conditions, it is possible to consider a bridge with inner wall(s) or pier(s).

- 1) Large negative impact on the social environment due to high elevation of the bridge.
- 2) The maximum size of the boulder(s) deposited in recent years is less than 0.5m in diameter.
- 3) When the girder height increases due to the long span bridge without pier, the social impact to the surrounding area become large.

#### 5.4 Estimation of Peak Flood Discharge of Debris Flow

Based on the data experienced in Japan as described in “The Study for the design criteria on the transit roads over devastated rivers, 1982, Technical Center for Sediment Control and Landslide, Japan”, the peak flood discharges of debris flow, normal debris flow and sediment flow are calculated as presented below.

##### 5.4.1 At Debris Flow Passing Section

The discharge at the gravel type and mud type debris flow passing section (riverbed gradient between 35%~17%) can be estimated using the relation recommended in the above study report. The relation recommended for discharge estimation for the maximum wave height of debris flow in the report is as follows.

*Max. Wave Height at Debris Flow Passing Section: Gradient 35~17%*

$$Q_{DF} = C_D Q_P \quad (1)$$

$$C_D = C_V / (C_V - C_d) \quad (2)$$

Where,

$Q_{DF}$  = Debris flow discharge ( $m^3/s$ ) at the tip of debris-flow

$Q_P$  = Peak flood discharge of normal flood flow ( $m^3/s$ )

$C_D$  = Discharge coefficient of debris-flow

$C_V$  = Volumetric sediment concentration of sediment deposit = 0.7

$C_d$  = Debris-flow concentration in flowage = at Gravel type 0.55, at Mud type 0.50

$Q_{DF} = 4.7Q_P$  Gravel type debris-flow for maximum wave height at the tip of debris-flow

$Q_{DF} = 3.5Q_P$  Mud type debris-flow for maximum wave height at the tip of debris-flow

Source: The Study for the design criteria on the transit roads over devastated rivers, 1982, Technical Center, Japan

However, the discharge at the debris flow passing section is not estimated because proposed bridges construction sites in Ghyampe, Mamti and Bhyakure tributaries fall in-between lower grade of debris flow stopping and sediment flow passing sections.

##### 5.4.2 At Debris Flow Stopping and Sediment Flow Passing Section

The debris flow discharge is the sum of peak flood discharge of the water (runoff) and the entrained boulders and sediment. The debris flow discharges in tributaries are estimated as presented below:

*2. Max. Wave Height at Normal Debris Flow Stopping and Sediment Flow Passing Section: Gradient 17~5%*

$$Q_{DF} = C_D Q_P \quad (3)$$

$$C_D = (1 - C_V)^{-1} \quad (4)$$

Where,

$Q_{DF}$  = Debris flow discharge ( $m^3/s$ )

$Q_P$  = Peak flood discharge of normal flood flow ( $m^3/s$ )

$C_D$  = Discharge coefficient of debris-flow for max. wave height at the tip of debris-flow

$C_V$  = Volumetric sediment concentration

Source: Discharge of landslide-induced debris flows: case study of Typhoon Morakot in southern Taiwan, Natural Hazards and Earth System Sciences: 14, 1719-1730, 2014

The coefficient of discharge ( $C_D$ ) depends on the sediment supplementation conditions. The value of  $C_D$  can be high when a watershed has high sediment supplementation.

The value of volumetric sediment concentration ( $C_V$ ) depends on the nature of debris flow as presented in Table 5-6 below.

Table 5-6 Value of Volumetric Sediment Concentration and Nature of Debris Flow

Adopted Debris flow type and bed gradient	Nature of debris flow* <sup>1</sup>	Value $C_V$ * <sup>1</sup>	Adopted $C_V$	$C_D = (1-C_V)^{-1}$
Debris flow stopping and sediment flow passing section (17~5%)	for Highly viscous debris flow	0.55 - 0.65	0.65	2.857
	for General viscous debris flow	0.48 - 0.55	0.50	2.0

Source: \*1 Discharge of landslide-induced debris flows: case study of Typhoon Morakot in southern Taiwan, Natural Hazards and Earth System Sciences: 14, 1719-1730, 2014

The debris flow in tributary is estimated as the sum of 100-year peak flood discharge of tributary and boulder, sediment entrained; the volumetric sediment concentration ( $C_V$ ) equals 0.65 and 0.50 are considered for highly and general viscous debris flows with boulders, respectively.

#### 5.4.3 At Sediment-Flow Section

The peak sediment flow discharge is the sum of peak flood discharge of the water (runoff) and the entrained sediment. Height of the peak sediment flow discharges in tributaries are estimated as presented below:

##### 3. Sediment Flow Section: Bed Gradient 5~2%

$$Q_{SF} = (1 + \beta)Q_P \quad (5)$$

Where,

$Q_{SF}$  = Peak Sediment flow discharge ( $m^3/s$ )

$Q_P$  = Peak flood discharge of normal flood flow ( $m^3/s$ )

$\beta$  = Discharge coefficient of sediment-flow of mixture rate of sediment

At steeper than 5% ( $>1/20$ ) 0.3

At 5~2% ( $1/20 \sim 1/60$ ) 0.3 ~ 0.1

Source: The Study for the design criteria on the transit roads over devastated rivers, 1982, Technical Center, Japan

Discharge coefficient for debris flows and sediment flow estimated in the tributaries are summarized in Table 5-7 below.

Table 5-7 Summary of Peak Flood Discharge Coefficient of Debris Flow

Riverbed gradient	Nature of debris flow	Discharge coefficient of flow $C_D$	Estimation of the maximum height of flow	Location of the project site
steeper than 35% ( $>1/3$ )	Debris-flow occurrence section	Not applicable	-	
35~25% ( $1/3 \sim 1/4$ )	Gravel type Debris-flow passing section	4.7	Maximum wave height of the tip of gravel type debris-flow	
25~17% ( $1/4 \sim 1/5$ )	Gravel type Debris-flow Stopping and Sediment-flow Passing section			
35~25% ( $1/3 \sim 1/4$ )	Mud type Debris-flow Passing section	3.5	Maximum wave height of the tip of mud type debris-flow	
25~17% ( $1/4 \sim 1/5$ )	Mud type Debris-flow Stopping and Sediment-flow Passing section			
17~5% ( $1/5 \sim 1/20$ )	Normal Debris-flow Stopping and Sediment-flow section	2.857~2.0	Maximum wave height of the tip of viscous debris-flow	Ghyampe, Manti, Bhyakure
5~2% ( $1/20 \sim 1/60$ )	Sediment-flow section	1.3~1.1	Peak sediment-flow discharge height	
2~1% ( $1/60 \sim 1/100$ )	Flood-flow section	1.0	Peak flood-flow discharge height	

Source: The Study for the design criteria on the transit roads over devastated rivers, 1982, Technical Center, Japan, etc.

## 5.5 Analysis of the Flood Flow in Tributaries

### 5.5.1 Open Channel Flood Flow Analysis

The analysis of normal and debris flow of 100-year return periods in the tributaries are analyzed by using Manning's equation for the open channel flow. The Manning's relation for the open channel flow is as presented below.

$$Q = \frac{A \cdot R^{\frac{2}{3}} \cdot S^{\frac{1}{2}}}{n} \quad \text{--- Manning's equation IRC:SP13-2004}$$

Where,

$Q$	=	Amount of flow ( $m^3/s$ )	
$A$	=	Cross-sectional area of flow ( $m^2$ )	$A = mH^2 + BH$
$R$	=	Hydraulic radius ( $m$ )	$R = A/P$
$S$	=	Hydraulic gradient of flow ( $m/m$ ) (= Design bed slope/gradient)	
$n$	=	Manning's roughness coefficient (-)	
$B$	=	Open channel width ( $m$ )	
$H$ ( $y$ )	=	Flow water depth ( $m$ )	
$P$	=	Perimeter ( $m$ )	$P = B + 2H$
$m$	=	Side bank slope 1( $V$ ): $m$	

$$V = Q/A$$

$$V = \text{Flow velocity (m/s)} \quad V = Q/A$$

$$H = [1/m \{ (B+2H(1+m^2)^{1/2})^{2/3} n Q / S^{1/2} \}^{3/5} - ZH^2]^{1/2} \text{ - Solving all the Equation by iteration process}$$

$$Z = Z = B/H$$

### 5.5.2 The Liner Waterway at HFL for each Tributary

The linear waterway of a bridge across an exclusively alluvial stream should normally be kept equal to the width required for stability that it is certain to come to regime according to Lacey. It will then be stable and have a section and slope conforming to his equations. For wide alluvial streams the stable width  $W$  can be taken equal to the wetted perimeter.

The hydraulic design process for sizing the bridge waterway opening shall include the evaluation of water surface elevations in the main channel for existing conditions and for proposed conditions. A comparison of the elevations between these two conditions shall be made to identify the effects of the bridge on the waterway. These results shall clearly identify and mitigate any backwater effects caused by the project.

### 5.5.3 Manning's Rugosity Coefficient

The values of Manning's rugosity coefficient ( $n$ ) recommended for different types of surface conditions in channel by H10: Hydrology Manual for Roads and Bridges, WECS, GON, 2018 are presented in Table 5-8.

Table 5-8 Manning’s Rugosity Coefficient n-value

Type of Channel and Description	Manning’s Rugosity Coefficient (n)		
	Minimum	Normal	Maximum
<b>1. Main Channels</b>			
a. clean, straight, full stage, no rifts or deep pools	0.025	0.030	0.033
b. same as above, but more stones and weeds	0.030	0.035	0.040
c. clean, winding, some pools and shoals	0.033	0.040	0.045
d. same as above, but some weeds and stones	0.035	0.045	0.050
e. same as above, lower stages, more ineffective slopes and sections	0.040	0.048	0.055
f. same as "d" with more stones	0.045	0.050	0.060
g. sluggish reaches, weedy, deep pools	0.050	0.070	0.080
h. very weedy reaches, deep pools, or floodways with heavy stand of timber and underbrush	0.075	0.100	0.150
<b>2. Flood Plains</b>			
a. Pasture no brush 1. Short grass	0.025	0.030	0.035
-----	---	---	---
<b>3. Mountain Streams, no vegetation in channel, banks usually steep, trees and brush along the banks submerged</b>			
a. Bottom: gravels, cobbles, and few boulders	0.030	<b>0.040</b>	0.050
b. Bottom: cobbles with large boulders	0.040	0.050	0.070

Source: H10: Hydrology Manual for Roads and Bridges, WECS, GON 2018

Comparing the conditions of proposed sites of Ghyampe, Mamti and Bhyakure tributaries, the natural condition of these streams is very close to the conditions of “Mountain streams, no vegetation in channel, banks usually steep, trees and brush along the banks submerged at high stages bottom: gravels, cobbles, and few boulders-Normal Conditions. The Manning’s roughness coefficient n-value from the above Table 5-8 has been selected equal to 0.040.

5.5.4 Channelized Waterway

The results of the analysis of normal flood flow of 100-year return period for different causeways sites have been calculated considering 38 m wide channel (bridge) with varying riverbed slopes are presented in Annex-5.

However, based on the outcome of the Topographic Survey recently conducted, the existing riverbed slopes (both upstream and downstream) of three causeway-sites are presented in the Table 5-9 below. The record of calculation of riverbed slopes has been presented in Annex-3.

Table 5-9 Waterway Opening and Bed Gradient Conditions for Open Channel Design

1. Ghyampe Khola Causeway

Elevation and Cross Section on Topo Survey Data		Opening Design Condition		
Elevation view at waterway		Present Slope	U/S	Flat 4%
			D/S	Channel 7%
			Free drop	Height 8m
Cross section view at existing road		Design River Training	U/S	Channelized
			D/S	Maintain
			Bed slope	Constant
		Present Condition	U/S & D/S	S = 7%
			Width	37 m
Design Horizontal Opening		Section Opening	Section	Open channel
			Width	38 m
			Slope	1:0.5
		QP 100-years		409 m <sup>3</sup> /s

### 2. Mamti Khola Causeway

Elevation and Cross Section on Topo Survey Data		Opening Design Condition		
Elevation view at waterway		Present Slope	U/S	Flat 5~6%
			D/S	Flat 6%
		Design River Training	Drop H.	Height 1~2m
			U/S	Channelized
Cross section view at existing road		Present	Condition	Flat
			Width	36 m
		Design Horizontal	Section	Open channel
			Width	38 m
		Opening	Slope	1:0.5
			QP 100-years	359 m <sup>3</sup> /s

### 3. Bhyakure Khola Causeway

Elevation and Cross Section on Topo Survey Data		Opening Design Condition		
Elevation view at waterway		Present Slope	U/S	Flat 2%
			D/S	Channel 4%
		Design River Training	Free drop	Height 8m
			U/S	Channelized
Cross section view at existing road		Present	Condition	Flat
			Width	43 m
		Design Horizontal	Section	Open channel
			Width	38 m
		Opening	Slope	1:0.5
			QP 100-years	431 m <sup>3</sup> /s

#### 5.5.5 Analysis of the Flood Flow in Tributaries

The results of the analysis of peak flood discharge of normal flood flow of 100-year return period in three tributaries considering 38 m wide channel (under the bridge) with varying riverbed slopes and design slope are presented in Table 5-10.

Table 5-10 Analysis of Velocity and Water Depth in Peak Flood Discharge

Description	Ghyampe Tributary							
	Varying riverbed slope for reference							Design S
	0.05%	0.10%	0.50%	1.0%	2.0%	5.0%	10.0%	
Peak flood discharge (m <sup>3</sup> /s)	409	409	409	409	409	409	409	409
Waterway under the bridge (m)	38.0	38.0	38.0	38.0	38.0	38.0	38.0	38.0
Manning's roughness c.: n	0.040	0.040	0.040	0.040	0.040	0.040	0.040	0.040
Velocity of flow (m/s)	1.62	2.04	3.43	4.26	5.30	7.04	8.72	7.8
Water depth under the bridge (m)	6.65	5.28	3.14	2.52	2.03	1.53	1.23	1.34

Description	Mamti Tributary							
	Varying riverbed slope for reference							Design S
	0.05%	0.10%	0.50%	1.0%	2.0%	5.0%	10.0%	<b>6.0%</b>
Peak flood discharge (m <sup>3</sup> /s)	359	359	359	359	359	359	359	359
Waterway under the bridge (m)	38.0	38.0	38.0	38.0	38.0	38.0	38.0	38.0
Manning's roughness c.: n	0.040	0.040	0.040	0.040	0.040	0.040	0.040	0.040
Velocity of flow (m/s)	1.55	1.95	3.27	4.06	5.04	6.70	8.29	7.0
Water depth under the bridge (m)	6.09	4.85	2.89	2.32	1.87	1.41	1.14	1.30

Description	Bhyakure Tributary							
	Varying riverbed slope for reference							Design S
	0.05%	0.10%	0.50%	1.0%	2.0%	5.0%	10.0%	<b>4.0%</b>
Peak flood discharge (m <sup>3</sup> /s)	431	431	431	431	431	431	431	431
Waterway under the bridge (m)	38.0	38.0	38.0	38.0	38.0	38.0	38.0	38.0
Manning's roughness c.: n	0.040	0.040	0.040	0.040	0.040	0.040	0.040	0.040
Velocity of flow (m/s)	1.65	2.07	3.49	4.35	5.40	7.18	8.90	6.6
Water depth under the bridge (m)	6.88	5.46	3.25	2.61	2.10	1.58	1.27	1.62

## 5.6 Determination of Length of the Bridges

### 5.6.1 General Considerations

It is desirable to determine the waterway width (hydraulic opening) of the river at bridge section to pass to the downstream side safely. The width is generally determined considering the following points. (Source: H10: Hydrology Manual for Roads and Bridges, WECS, GON 2018)

- The contributing watershed area
- The magnitude and frequency of the design discharge
- The roadway alignment and profile, and
- Physical and environmental constraints

The hydraulic design process for sizing the bridge waterway opening shall include the evaluation of water surface elevations in the main channel for existing conditions and for proposed conditions. A comparison of the elevations between these two conditions shall be made to identify the effects of the bridge on the waterway. These results shall clearly identify and mitigate any backwater effects caused by the project (*ibid*).

As per Clause 104.3 of IRC:5-1998, linear waterway should be equal to Lacey's regime waterway given by the following equation:

$$W = CQ_P^{1/2} \quad \text{--- Lacey's Regime Condition} \quad \text{Clause 104.3, IRC:5-1998}$$

Where,

- $W$  = Regime width (m) equal to effective linear waterway under regime condition  
 $C$  = a constant usually taken as 4.8 for regime channels but it may vary from 4.5 to 6.3 according to local conditions.  
 $Q_P$  = Peak flood discharge of normal flood flow (m<sup>3</sup>/s)

Lacey's regime waterway width is calculated as below.

Tributary	Flood discharge $Q_P$ (m <sup>3</sup> /s)	Proposed waterway $W_P$ (m)	Lacey's regime width $W = 4.8Q_P$ (m)	Ratio $W_P / W$
Ghyampe	409	38	97	39% ( $\approx 1/3^{\text{rd}}$ )
Mamti	359	38	91	42% ( $\approx 1/2^{\text{nd}} \sim 1/3^{\text{rd}}$ )
Bhyakure	431	38	100	38% ( $\approx 1/3^{\text{rd}}$ )

The linear waterway of a bridge across an exclusively alluvial stream should normally be kept equal to the width required for stability that it is certain to come to regime according to Lacey. It will then be stable and have a section and slope conforming to his equations.

Following points need to be considered for estimation of desirable linear waterway width of bridge at various type of alluvial streams.

1. For wide alluvial streams, the stable regime width (W) can be taken equal to the wetted perimeter (P).
2. For large alluvial streams as an unstable meandering streams where meandering over a wide belt, may have several active channels separated by bars, island or shallow section, the total width of the streams may be more than the regime length, no need to consider bridge length longer than the regime length.
3. The linear waterway of the bridge across an alluvial stream should not be less than the regime width of the stream, contraction need to be avoided.
4. For semi alluvial streams, when the banks of a stream are high, well defined and rigid but the bed is alluvial, the linear waterway of the bridge should be made equal to the actual surface width of the stream, measured from edge to edge of water along the Highest Flood Level (HFL) on the plotted cross-section at which the designed maximum discharge can be passed without creating harmful afflux.
5. For streams with rigid boundaries, some reduction in the linear waterway may, across some streams with moderate velocity, be possible.
6. For flashy rivers and if the bed can withstand against scour, the waterway should be determined by the area velocity method taking into account the design flood level and its water spread, the characteristics of the bed materials and the water surface slope. (stated in IRC: 5-1998 Clause 104.4)

Judging by several physical characteristics stated above, the proposed three streams (Bhyakure, Manti and Ghyampe) are very close to category stated above in point 6, point 5 and point 4 and even among them, very close to point No. 6, flashy streams. Further explanation will be made in the following sections.

#### 5.6.2 Waterway in a Hilly or Mountainous Terrain

Mazumdar describes, "In a hilly or mountainous terrain where the river flows in gorges with steep bed slope, the flow is usually in supercritical state when depth (y) is small and velocity of flow (V) is very high, in supercritical flow, Froude's number of flow, defined as  $F_r = V/(gy)^{1/2}$ , is more than one (1.0). Lacey's regime waterway in such situations is very high compared to liner waterway at HFL. Thus, the minimum waterway under the bridge will be determined by the liner waterway at HFL and not by Lacey's regime waterway. In fact, Lacey's regime condition is not valid in such a terrain at all." (Source: Mazumdar S. K., *Determination of Waterway under A Bridge in Himalayan Region – Case Studies, Article*)

$$F_r = V/(g y)^{1/2} \quad \text{--- Froude's Number of Flow}$$

Where,

- $F_r$  = Froude's number of flow (-)  
 $V$  = Velocity of flow (m/s)  
 $g$  = Acceleration due to gravity 9.81 (m/s<sup>2</sup>)  
 $y$  = Flow water depth (m)

Judgement,

- $F_r > 1.0$       *Supercritical flow: No restriction of Lacey's regime waterway*  
 $F_r = 1.0$       *Critical flow*  
 $F_r < 1.0$       *Sub-critical flow: The waterway restricted Lacey's regime waterway*

For supercritical flow ( $F_r > 1$ ) minimum waterway under the bridge will be determined by the linear waterway at HFL corresponding to design flood discharge.

The Froude's number of three tributaries at design discharge flood corresponding to 38 m width are presented in Table 5-11 below. The flow condition in all three tributaries are observed as supercritical and hence the Lacey's regime condition cannot be valid.

Table 5-11 Determination of the Width by the Linear Waterway at HFL

Tributary	Peak flood discharge $Q_p$	Designed riverbed slope $S$	Proposed condition of channel width	Velocity of flow $V$	Flow water depth $y$	Froude's number of flow $F_r$	Determined waterway width
	$m^3/s$	%	m	m/s	m	-	m
Ghyampe	409	7	38	7.8	1.3	$1.7 > 1.0$	38
Mamti	359	6	38	7.0	1.3	$1.6 > 1.0$	38
Bhyakure	431	4	38	6.6	1.6	$1.4 > 1.0$	38

Source: JICA Expert Team

### 5.6.3 Verification of the Past Experience

Sindhuli Road (Dhulikhel- Sindhuli- Bardibas Road), 54 numbers of waterway bridges and structures are constructed in total 160 km of the road with flat, hilly/rolling and mountainous terrain. In Section III of the last, twelve (12) box-type causeways (concept is a submerged bridge) were constructed which have been summarized and presented in Table 5-12 below.

Table 5-12 Historical Record of the Waterway Structures Completed in Sindhuli Road

SN	Construction Period (Duration)	Section (Length)	Location	Type of Terrain	Waterway Crossing Structure		
					Bridge	Box type Causeway	Floodway (Causeway)
1	1996-1998 (3 years)	Section I (37 km)	Bardibas(0km)-Bhiman	Plain (Terai)	2	-	-
			Bhiman-Sindhuli Bazar	Hilly (Siwalik zone along Kamala river)	7	3	14
2	1997-2005 (7 years)	Section IV (50 km)	Nepalthok-Bhakundebesi	Hilly (along Roshi)	5	-	8
			Bhakundebesi-Dhulikhel(160km: end)	Mountainous	-	-	-
3	2000-2009 (9 years)	Section II (36 km)	Sindhuli Bazar-Gwang	Hilly (along Gwang river)	1	2	-
			Gwang-Khurkot	Mountainous (Mahabharat)	-	-	-
4	2009-2015 (6 years)	Section III (37 km)	Khurkot-Nepalthok	Hilly & Steep (along Sunkoshi river)	-	12	-
Total					15	17	22

Source: JICA Expert Team

Three (3) of them are designed bridge length in which the adopted width is as around  $1/3^{rd}$  of the original alluvial stream width. The list and characteristics of these box type causeways are summarized and presented in Table 5-13.

Table 5-13 The list and Characteristics of 12 nos. Box-type Causeways in Sindhuli Road Section III

SN	Name of Tributary (Khola)	No.	Catchment Area A km <sup>2</sup>	Bed Slope S %	Peak Flood Discharge Q <sub>P</sub> m <sup>3</sup> /s	Calculated Velocity V m/s	Waterway Width at planed Road m	Constructed Causeway Length L m	Froude's number of Flow F <sub>r</sub> -	Lacey's Waterway Width W m (L/W%)	Max. Rolling Boulder Dia. m	Assumed Section in Devastated Tributaries/Alluvial Stream
1	Andheri	No.1	19.2	3.4	987	4.8	130	130	1.0	151 (86%)	0.5	Debris-flow stopping
2	Jagire	No.2	1.3	5.7	62	3.3	30	30	0.9	38 (79%)	-	Debris-flow stopping
3	Bhadaure	No.3	4.0	10.9	186	5.3	50	50	1.2	-	-	Debris-flow passing
4	Bhalu	#1	0.6	11.0	29	5.8	30	30	2.3	-	1	Debris-flow passing
5	Niguli	#2	21.7	3.4	1,101	3.2	190	190	0.5	159 (119%)	2	Debris-flow stopping
6	Gadaule	#3	0.7	8.9	37	7.6	20	20	2.1	-	-	Debris-flow stopping
7	Chainpur	#4	18.2	2.5	922	9.4	170	50	1.7	-	1.5	Debris-flow
8	Khahare	#5	4.5	6.9	230	5.0	120	90	1.7	-	0.75	Debris-flow stopping
9	Bhote	#6	18.0	3.2	916	8.8	70	40	1.5	-	1	Debris-flow stopping
10	Gangate	#7	19.0	2.9	966	7.7	130	60	1.5	-	0.75	Debris-flow
11	Dhamile	#8	28.4	3.2	1,439	7.9	190	70	1.2	-	1.5	Debris-flow stopping
12	Sadhi	#9	7.2	5.0	366	7.1	90	90	1.9	-	0.3	Debris-flow stopping

Source: JICA Expert Team

Since a significant period has already been elapsed after completion of these bridge and they are performing satisfactorily till now. Table 5-14 shows the three causeways and their present conditions in details.

Table 5-14 Present Conditions of Three Causeways which were built with 1/3<sup>rd</sup> Constriction

SN	Name of Tributary	Alluvial Stream Original Width	Froude's Number of Flow F <sub>r</sub>	Causeway Length	Constriction Rate	Public Protest while Construction requested with Bandha	Bank Protection Work done by DWIDP (now DWRI)	Actual waterway width after protection wall constructed	Present Condition of the waterway
7	Chainpur	170 m	1.7	50 m	29% (≅ 1/3 <sup>rd</sup> )	Protection of the rice field at U/S and D/S side in waterway	Construct gabion wall along the government land and narrowed waterway	20 m -12%	Calm
10	Gangate	130 m	1.5	60 m	46% (≅ 1/3 <sup>rd</sup> )	Protection of the cultivated land/rice field located in the upstream waterway	Construct dry rip-rap along the government land and narrowed waterway	15 m -12%	Calm
11	Dhamile	190 m	1.2	70 m	37% (≅ 1/3 <sup>rd</sup> )	Protection of the rice field at U/S and D/S side in waterway	Construct gabion wall along the government land and narrowed waterway	20 m -11%	Calm

Source: JICA Expert Team

The following illustrations showing the arrangement of bridge realized at various locations of Sindhuli Road Section 3 presented in Figures 5-3 to 5-5.

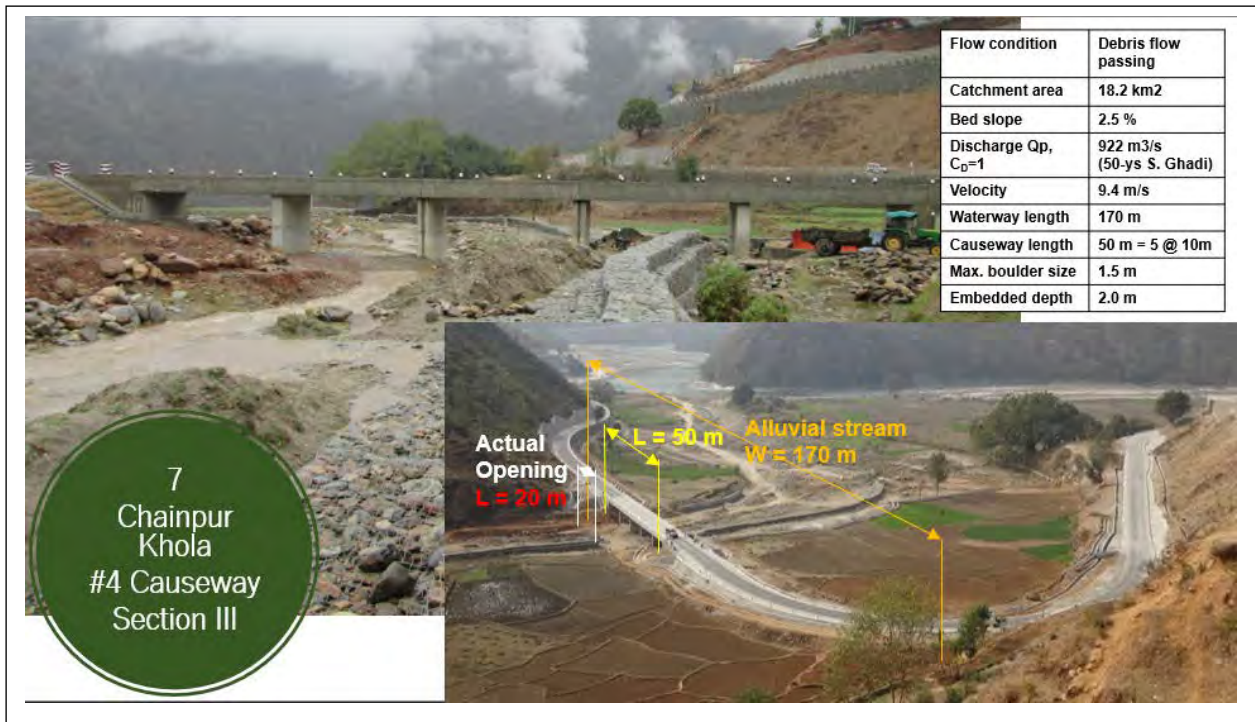

Figure 5-3 Present Condition of Chainpur Khola Causeway, Sindhuli Road (Section-III)

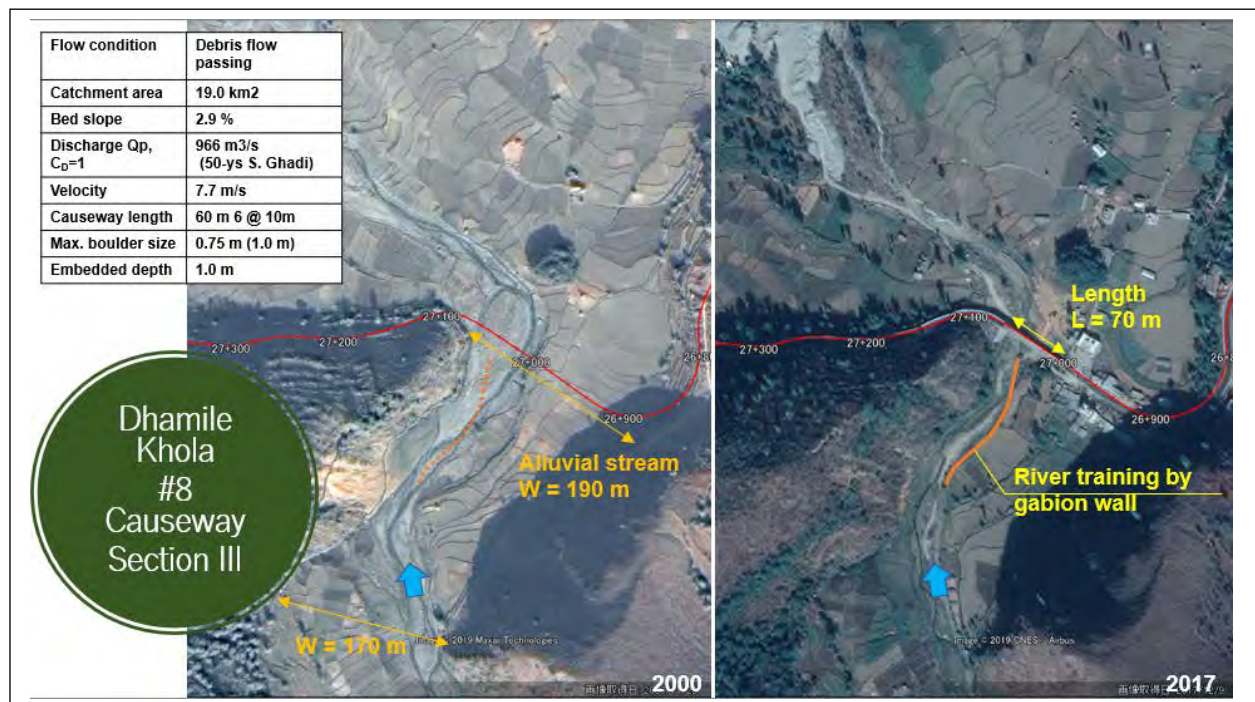

Figure 5-4 Present Condition of Gangate Khola Causeway, Sindhuli Road (Section-III)

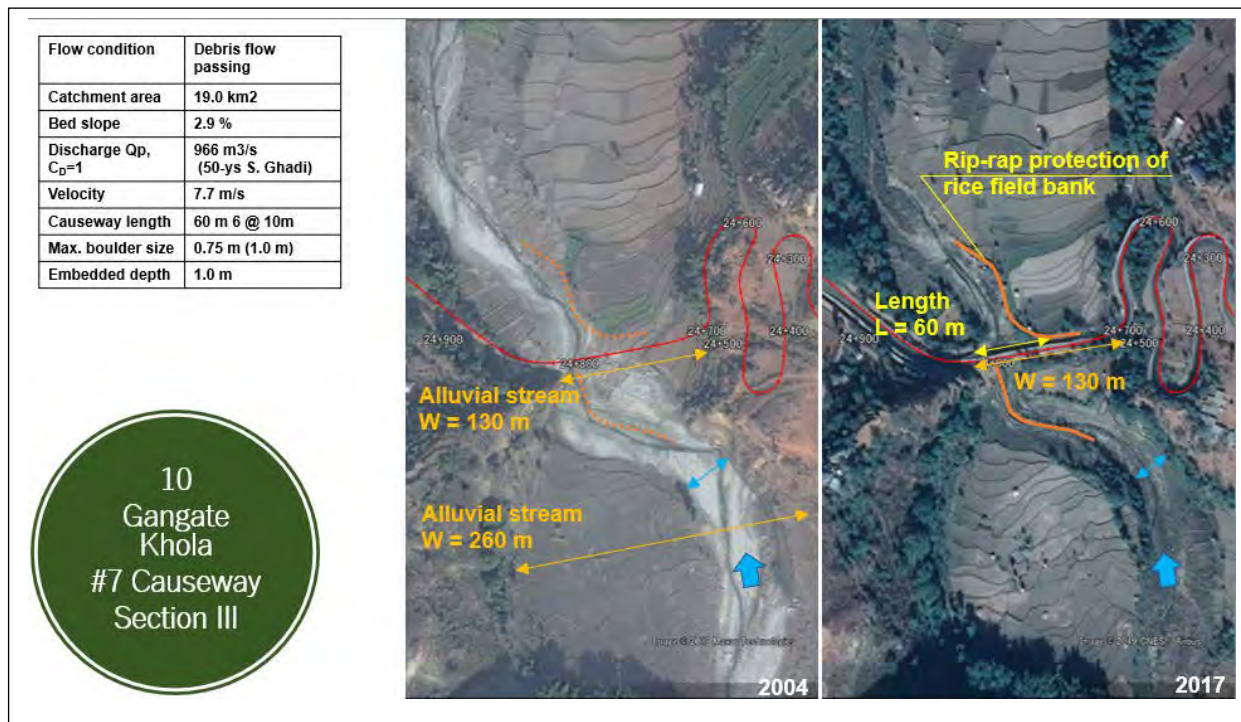

Figure 5-3 Present Condition of Dhamile Khola Causeway, Sindhuli Road (Section III)

5.6.4 Verification of the Social Impact by the Scale of the Bridges construct in Dense Area

Sindhuli Road is serving as a linkage between Kathmandu and Eastern Nepal (mountain, hilly and Terai). Many villages along Sindhuli Road on either side are getting developed slowly. The people started to come and settle in the vicinity along the road. Because of increase in the population, the other social institutions like schools, health posts, restaurants etc. and other infrastructures are also set up. Many crusher plants have started their activities from the recent past. As a result, there is big pressure on the land nearby, public (Government) and private land. Therefore, social aspect has also become one of the complicated issues these days and is needed to be considered with high priority.

A comparison on technical parameters (from Hydrological and Hydraulic points of view) are summarized in Table 5-15 for two different waterways of the bridges (i) 40m length and (ii) 80m length.

Table 5-15 Comparison of Technical Parameters for two Different Waterways of the Bridges

Bridge length			Peak flood discharge	(i) 40 m length			(ii) Alternative 80 m length		
Waterway opening width				38 m			78 m (Highly Safety for Climate Change)		
Flood-flow and Debris-flow for Max. Wave height C <sub>D</sub> (Q <sub>DF</sub> = C <sub>D</sub> Q <sub>F</sub> )			Q <sub>p</sub>	Normal	Sediment flow	Sediment flow Hi	Normal	Sediment flow	Sediment flow Hi
			m <sup>3</sup> /s	1.0	2.0	2.857	1.0	2.0	2.857
Ghyampe Tributary	Velocity	m/s	403	7.8	-	-	6.6	-	-
	Water Hight	m		1.3	-	-	0.9	-	-
	Tip Wave H.	m		1.3	2.0	2.4	0.9	1.3	1.6
Mamti Tributary	Velocity	m/s	359	7.0	-	-	6.0	-	-
	Water Hight	m		1.3	-	-	0.8	-	-
	Tip Wave H.	m		1.3	1.9	2.4	0.8	1.2	1.5
Bhyakure Tributary	Velocity	m/s	431	6.6	-	-	5.7	-	-
	Water Hight	m		1.6	-	-	1.1	-	-
	Tip Wave H.	m		1.6	2.4	3.0	1.1	1.6	2.0

Source: JICA Expert Team

Likewise, a comparison of many aspects including social impact for two different waterways of the bridges has been prepared and presented in Table 5-16.

Table 5-16 Comparison of two Waterways including Social Aspects

Site	Subject	Bridge length 40m		Alternate Plan: length 80m		
		Cost, Quantity	Remarks	Cost, Quantity	Remarks	
Ghyampe	Construction Cost (ratio)	1.0	PC T-girder br.	1.58	Pier assumed open foundation	
	Construction Period	21 months	Minimum	32 months		
	Social impact	Relocation house in 25m ROW	-		5 houses	
		Relocation house out of ROW	-		-	
		Land acquisition	200 m2		1,125 m2	
Public Protest	Normal		Very High			
Mamti	Construction Cost (ratio)	1.0	RC-continuous slab bridge	1.60	RC-continuous slab bridge	
	Construction Period	21 months	Minimum	32 months		
	Social impact	Relocation house in 25m ROW	1 house		2 houses	
		Relocation house out of ROW	-		1 house	
		Land acquisition	150 m2		4,000 m2	ex. Crushing plant and Cultivated land
Public Protest	Normal		Very High			
Bhyakure	Construction Cost (ratio)	1.0	PC T-girder br.	1.57	Pier assumed open foundation	
	Construction Period	21 months	Minimum	32 months		
	Social impact	Relocation house in 25m ROW	1 house		5 houses	
		Relocation house out of ROW	-		-	
		Land acquisition	200 m2		2,900 m2	School's play ground Under expanding
Public Protest	Normal		Very High			

Source: JICA Expert Team

The effect of complexity of social expect is illustrated on the following Figure 5-6 and Figure 5-7 for Bhyakure Tributary for example (1) Case-1 waterway width 40m, and (2) Case-2 waterway width 80m respectively.



Figure 5-4 Case-1, Waterway Width 40m, Illustration on Social Aspects – Bhyakure Tributary



Figure 5-5 Case-2, Waterway Width 80m, Illustration on Social Aspects – Bhyakure Tributary

5.6.5 Conclusion of Selection of the Bridge Size

Considering all the explanations explained above, the conclusion regarding the length of proposed three bridges under pilot project has been finalized as 40m long bridge as described in Table 5-17.

Table 5-17 Summary of Structure Conditions

Conditions			Ghyampe	Mamti	Bhyakure
Bridge length (Waterway opening)	Proposed bridge length based on terrain condition		40m	40m	40m
	Proposed Waterway width		38m	38m	38m
	Required by Lacey’s regime formula		97m	91m	100m
	Linear waterway at the HFL	Terrain	Hilly	Hilly	Hilly
		Froude’s number	$1.7 > 1$	$1.6 > 1$	$1.4 > 1$
Flow condition		Supercritical	Supercritical	Supercritical	
	Bridge length determination	40m	40m	40m	
Social Impact	Surrounding Conditions		Dense area	Dense area	Dense area
	Long span bridge Safety for 80 m		High	High	High
	Girder height Requirement		Moderate	Minimize	Moderate
Floating debris	Drift log or roots	Drift	Non	Non	Non
		Roots of wood	Non	Non	Non
	Boulder size	no. 10 <sup>th</sup> diameter of particle	1m	0.5m	1m
Social impact	Girder height	Affected	Moderate	Hard	Moderate

### 5.7 Vertical Clearance of the Bridge

#### 5.7.1 Design Policy

The vertical clearance of the bridge structure across the waterway/river possible debris/flood flow will be designed in accordance with the concept described in the study report of the study on the Study for the design criteria on the transit road over devastated river, 1982, Technical Center for Sediment Control and Landslide, Japan.

The reason for studying the sedimentation of debris-flow or sediment-flow is that it is necessary to secure a girder height to allow the sediment to flow down even if a flood-flow occurs.

There is a possibility that the opening could be blocked with soil materials and others. Connection with the bearing is suitable between the superstructure and sub-structure, because in a big flood, superstructure is most possibly subjected to damage and of easy repairing.

Table 5-18 Selection Policy of a Pier in Waterway

Patterns of debris-flow	Debris condition		Possibility of Damage			Availability	
	Boulder	Driftwood	Overflow	Blockage of opening	Damage to pier	One span	Pier
Debris-flow passing/	Huge	-	Yes	Yes	Yes	○	×
Debris-flow passing/	Exist	-	Yes	Yes	Yes	○	×
Debris-flow stopping	Exist	-	No	Yes	Yes	○	×
Debris-flow stopping	Few	Case :Non	No	No	Yes	○	○
Sediment-flow	Non	Case :Non	No	No	No	○	○
Flood-flow	Non	Case :Non	No	No	No	○	○

#### 5.7.2 Vertical Clearance

The vertical clearance of the bridge shall be equal to or greater than the sum of the respective heights shown below and in Table 5-19 in the two cases of the Case-1 against the passing of debris-flow or sediment-flow and Case-2 against the deposition of debris or sediment flow in Figure 5-8 below.

The reason for considering deposition of debris-flow or sediment-flow is that it is necessary to secure a girder height to allow a deposition to flow down even if a flood occurs.

The relationship between girder height when debris-flow and sediment-flow are passed, and the relationship between the accumulation of debris-flow and sediment-flow and the crossover point is shown in Table 5-19.

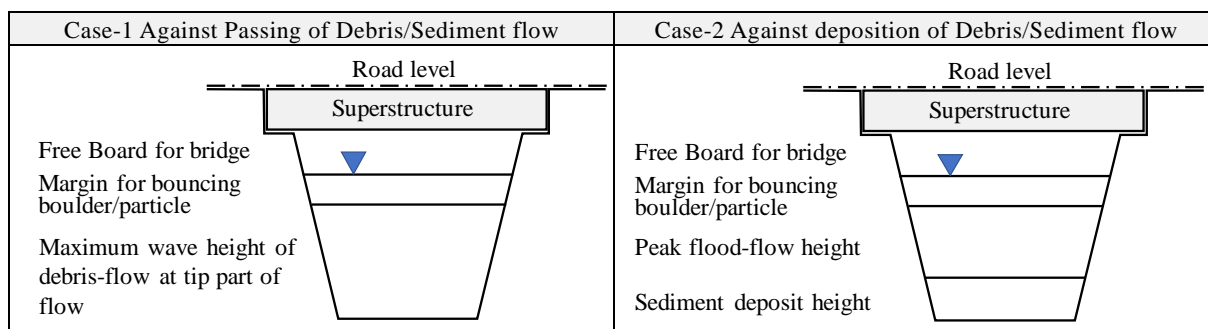

Figure 5-6 Definition of Two Cases of Vertical Clearance



5.7.3 Determination of Maximum Wave Height of Debris-Flow

(1) Characteristics of the Rivers where Damaged Causeways are located

The Pilot Project of the selected damaged causeways will be reconstructed by bridge structure as shown in Table 5-20. Planned road height will be determined based on the high-water level, with margin provided based on flood discharge calculated by hydrological analysis.

5.7.4 Criteria for Fixing the Vertical Clearance of the Bridge

(1) Flow Water Depth (Clearance for Flow) ( $H_{DF}$ ,  $H_{FF}$ )

Table 5-20 Characteristics of the Pilot Project Site Tributaries for Hydraulic Analysis

SN	Tributary Name	Adopted Flow Type of Tributary			Max. Size of Boulder	Water Stream Opening Width	Length of Bridge	Peak Flood Discharge $Q_P$	Design Constant Riverbed Slope S
		Grading of bed gradient	Flow Type of Tributary	Road Crossing Section					
		%	-	-					
1	Ghyampe	17%~5%	Gravel type Highly Viscous Debris-flow	Passing/ Stopping of Debris-flow	1.0	38	40	409	7 %
2	Mamti	17%~5%	Gravel type Highly Viscous Debris-flow	Passing/ Stopping of Debris-flow	0.5	38	40	359	6 %
3	Bhyakure	17%~5%	Gravel type Highly Viscous Debris-flow	Passing/ Stopping of Debris-flow	1.0	38	40	431	4 %

Source: JICA Expert Team

The situation of debris and flood flow will be changed according to the tributary/river gradients as below. In these three bridges, the superstructure height is planned to satisfy for both cases of Case1 against stopping of high viscous debris flow passing and Case 2 debris-flow/sediment-flow at sedimentation.

The clearance will be designed for the three bridges at gradient of riverbed 17% ~ 5% on Table 5-21.

Table 5-21 Vertical Clearance under different cases

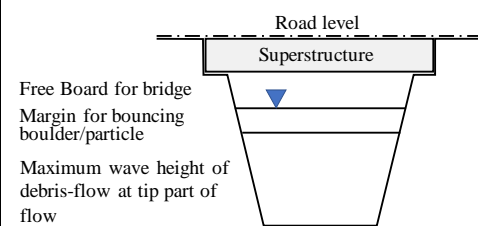
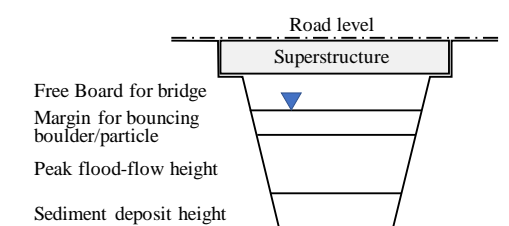
Clearance Items	Case 1 Against Stopping of Debris-flow and Passing of Sediment-flow		Case 2 Against Sedimentation of Debris-flow	
	Sediment deposit depth	-	-	Maximum Stopping Particle size ( $H_{SD}$ )
Hight of flow water depth	Maximum Wave height of Highly Viscous Debris-flow At the tip of debris-flow ( $H_{DF}$ )	Calculation discharge $Q_{DF}=2.857Q_P$ ( $2.0Q_P$ )	Height of Peak Flood-flow ( $H_{FF}$ )	Calculation discharge $Q_P$
Additional clearance for floating debris	Clearance for Graval type Debris-flow (Height of a bouncing boulder) ( $H_{DC}$ )	Dia. of a max. size boulder at site	Clearance for Graval/ Mud type debris-flow (Height of a bouncing boulder) ( $H_{DC}$ )	Dia. of a max. size boulder at site
Free board for bridge	Free Board for Bridge based on $Q_{DF}$ ( $H_{FB}$ )	by NBS 2067	Free Board for Bridge based on $Q_P$ or $Q_{DF}$ for safety ( $H_{FB}$ )	by NBS 2067
Vertical clearance to be secured under the superstructure (girder or top slab)				

(2) Height of Flow Water Depth ( $H_{DF}$  and  $H_{FF}$ )

Calculations of peak flood-flow  $Q_P$  and maximum wave height of debris-flow ( $Q_{DF} = 2.0Q_P$  &  $2.857Q_P$ ) with three bridges at designed riverbed slope ( $S$  %) have been presented in Table 5-22.

Table 5-22 Flow Water Depth at Debris-Flow and Flood-Flow, Calculation by Manning’s Equation

Tributary	General Parameter			Hydraulic Parameters of Rivers									
	$Q_P$ m <sup>3</sup> /s	$C_D$ -	$C_D Q_P$ m <sup>3</sup> /s	$n$ -	$S$ %	$Z=B/H$ -	Side bank slope -	Flow water depth $y$ m	Calculated width $B$ m	X-Area m <sup>2</sup>	Velocity $V$ m/s	$P$ m	$R$ m
Ghyampe	409	1	409	0.04	7%	28.0	1:0.5	<b>1.349</b>	37.38	52.78	7.8	41.59	1.27
		2.0	818	0.04	7%	18.5	1:0.5	2.044	37.82	81.51	-	43.61	1.87
		2.857	1169	0.04	7%	15.4	1:0.5	<b>2.504</b>	38.57	102.87	-	45.65	2.25
Mamti	359	1	359	0.04	6%	29.5	1:0.5	<b>1.296</b>	38.24	51.26	7.0	41.91	1.22
		2.0	717	0.04	6%	19.5	1:0.5	1.962	38.27	78.94	-	43.82	1.80
		2.857	1024	0.04	6%	15.8	1:0.5	<b>2.429</b>	38.37	99.10	-	45.24	2.19
Bhyakure	431	1	431	0.04	4%	24.0	1:0.5	<b>1.619</b>	38.86	65.56	6.6	43.44	1.51
		2.0	861	0.04	4%	15.6	1:0.5	2.466	38.66	100.94	-	45.44	2.22
		2.857	1230	0.04	4%	12.5	1:0.5	<b>3.067</b>	38.33	126.96	-	47.01	2.70

Source: JICA Expert Team

(3) Sediment Deposit Depth ( $H_{SD}$ )

The deposit height at the tip of the leading-edge deposition depth of the debris/sediment-flow is regulated by the local conditions, so it is necessary to thoroughly research and determine the site condition. In the gravel debris flow, the average is 5 to 6 m (up to 10 m in the past) in the valley bottom plain, and the average is 3 to 5 m in the alluvial fan. However, if the river channel cannot be maintained at a uniform, stable slope and it is expected that maintenance of the river channel and structures will be difficult for a long time after the construction, it is necessary to safely consider for the impact of channel blockage due to deposition height.

Sediment deposit depth shall be adopted with max. size of boulder at tip of debris-flow. Max. size of boulder at the Graval type debris-flow stopping section are around 1.0 m at Ghyampe, Mamti and Bhyakure tributaries. A definition sketch of debris-flow and sediment or flood flow have been presented in Figure 5-9.

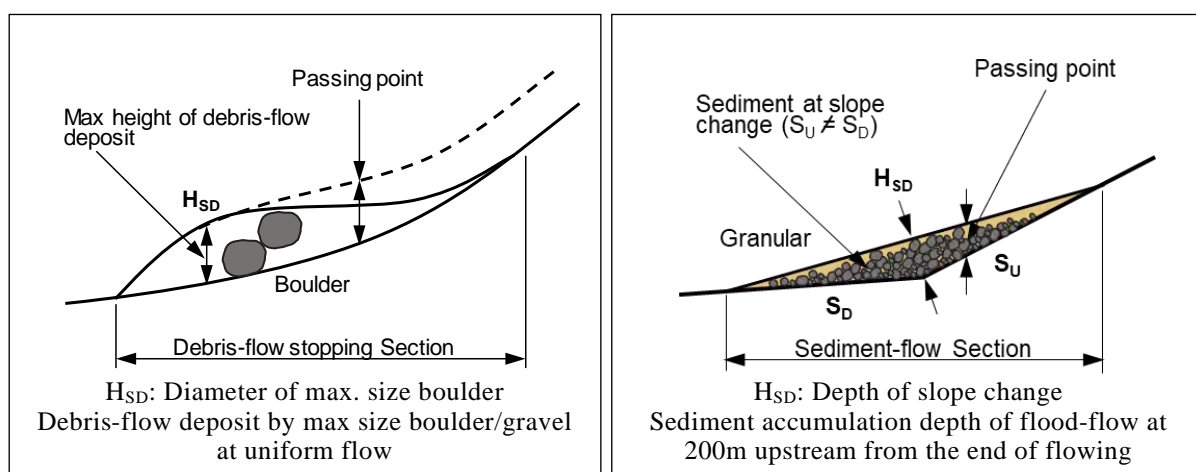

Figure 5-7 Definition Sketch of Debris-flow and Sediment-flow

(4) Debris Clearance ( $H_{DC}$ )

Debris-flow

The margin for the maximum wave height ( $H_{DC}$ ) of the debris-flow is considered to be the bouncing height of one grain size of the boulder/cobble at the tip of the gravel-type or mud-type debris flow, and

this maximum gravel diameter is determined by field reconnaissance. It will be the thickness of a maximum size of boulder/cobble carried on a tip of high flow wave.

**Sediment-flow and Flood-flow**

Criteria for fixing the vertical clearance of bridge at different debris flow moving sections of the river are presented in Table 5-23 and 5-24. The values of sediments deposits, clearance for debris and normal free board for bridge designing would be fixed considering the bridge standard of DOR or as per the recommendations of bridge expert of the DOR.

Table 5-23 Hight of Margin for Sediment-flow

Range of Discharge of Sediment flow	Hight of Margin for Sediment flow
Less than 200 m <sup>3</sup> /s	0.6 m
More than 200 m <sup>3</sup> /s and less than 500 m <sup>3</sup> /s	0.8 m

Table 5-24 Hight of Margin for Flood-flow

Range of Discharge of Flood flow	Hight of Margin for Flood flow
Less than 200 m <sup>3</sup> /s	0.6 m
More than 200 m <sup>3</sup> /s and less than 500 m <sup>3</sup> /s	0.8 m

Source: The Study for the design criteria on the transit roads over devastated rivers, 1982, Technical Center, Japan

(5) Free Board for Bridge (H<sub>FB</sub>)

In case of bridges over water bodies, the free board from the design HFL with afflux to the lowest point of bridge superstructure shall not be less than 1.0 m. The minimum freeboard for the bridge shall be as shown on the Table 5-25 below, stipulated in Table 8.1 of Nepal Bridge Standard 2067.

Table 5-25 Minimum Free Board for Bridge from the design HFL

SN	Discharge (m <sup>3</sup> /sec)	Minimum Free Board (m)
1	Less than 200	1.0
2	201 - 500	1.2
3	501 - 2000	1.5
4	2001 - 5000	2.0
5	5000 and above	More than 2.0 (depending on the reliability of the available data for the calculated of discharge)

Source: Nepal Bridge Standard 2067 (NBS)

5.7.5 Determination of Vertical Clearance

A definition sketch showing various aspects of vertical clearance based on the hydraulics requirement for open foundation and raft foundation are presented in Figure 5-10 and Figure 5-11 below.

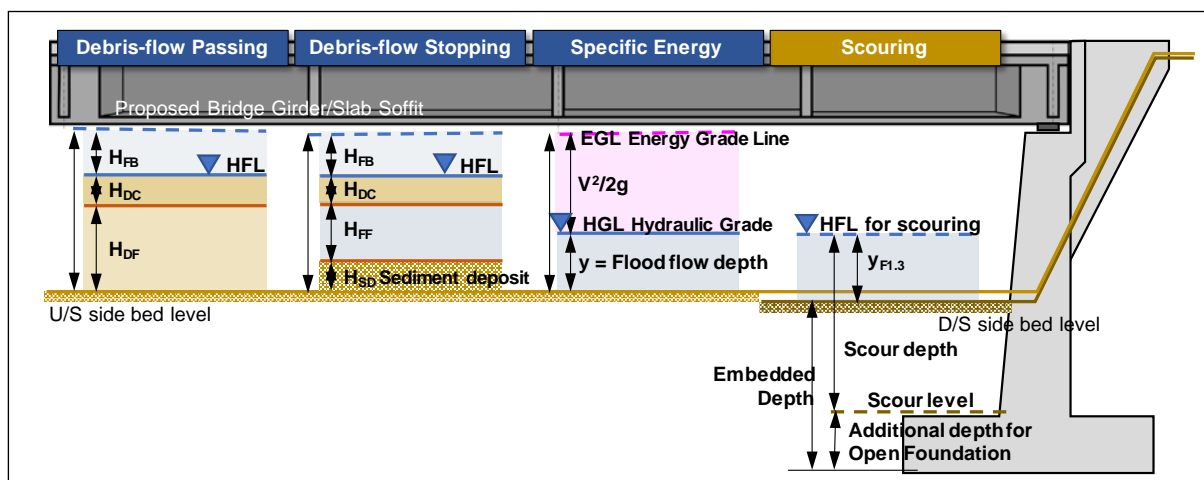

Figure 5-8 Definition Sketch of Vertical Clearance for Open Foundation

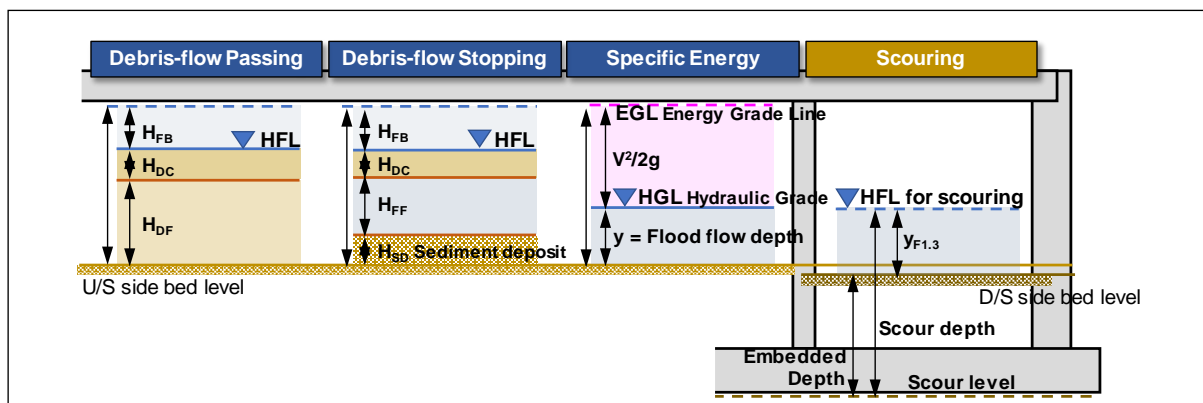

Figure 5-9 Definition Sketch of Vertical Clearance for Raft Foundation

The Vertical Bridge Clearance basically can be defined from the following two cases by the linear waterway at HFL (Case-1 & 2) and Specific Energy Head (Case-3).

- (1) The Linear Waterway at HFL corresponding to Design Flood Discharge (Case-1 & 2)

Case-1: Crossover point against passing of debris-flow

$H_{VC1}$  Against Passing of Normal Debris-flow (Bed Slope  $S=17\sim5\%$ )

Where,

- $H_{DF}$  = Maximum wave height of sediment-flow at tip of debris-flow  $Q_{DF}=2.857Q_P$  (m)
- $H_{DC}$  = Clearance for gravel/mud type debris-flow (m)
- $H_{FB}$  = Free board for bridge based on  $Q_{DF}$  (m) = Maximum size of boulder
- $H_{VC1}$  = Vertical clearance =  $H_{DF} + H_{DC} + H_{FB}$  (m)

Case-2: Crossover point against deposition of debris-flow

$H_{VC2}$  Against Sedimentation of Debris-flow (Bed Slope  $S=17\sim5\%$ )

Where,

- $H_{SD}$  = Sediment deposit depth (m) = Maximum size of boulder at uniform channel
- $H_{FF}$  = Height of peak flood-flow at  $Q_P$  (m)
- $H_{DC}$  = Clearance for gravel/mud type debris-flow (m) = Maximum size of boulder
- $H_{FB}$  = Free board for bridge based on  $Q_P$  (m)
- $H_{VC2}$  = Vertical clearance =  $H_{SD} + H_{FF} + H_{DC} + H_{FB}$  (m)

To pass normal and debris flows of 100-year return period from bridges safely the vertical clearance of the bridges are determined considering the free board of 1.5m (1.2m for normal flood and 1.5m for debris-flow) and the two-meter (2.0m) margin recommended by the DOR. The two-meter margin recommended by DOR is used for compensating the reduced clearance by sediment deposition (1.0m) and for providing clearance to debris (1.0m). The design vertical clearances for bridges to be constructed in the tributaries are presented in Table 5-26 and Table 5-27 below.

Table 5-26 Calculation of Vertical Clearance Case-1 against Passing of Highly Viscous Debris-flow  
Bridge Opening = 38.0m

Tributary	100-year Return Period		Design Riverbed Slope S %	Velocity of flow at $Q_P$ V m/s	Vertical Clearance			Total Clearance Height $H_{VC1} = H_{DF} + H_{DC} + H_{FB}$ m
	Flood-flow $Q_P$ m <sup>3</sup> /s	at Max. Wave Debris-flow $Q_{DF}=2.857Q_P$ m <sup>3</sup> /s			Max Wave Flow height $y$ $H_{DF}$ m	Clearance of Debris-flow $H_{DC}$ m	Free Board at $Q_{DF}$ $H_{FB}$ m	
Ghyampe	409	1169	7	7.8	2.5	1.0	1.5	5.0
Mamti	359	1024	6	7.0	2.4	1.0	1.5	4.9
Bhyakure	431	1230	4	6.6	3.1	1.0	1.5	5.6

Source: JICA Expert Team

Table 5-27 Calculation of Vertical Clearance Case-2 considering Sedimentation of Debris-flow  
 Bridge Opening = 38.0m

Tributary	100-year Return Period Flood-flow $Q_P$ m <sup>3</sup> /s	Design Riverbed Slope $S$ %	Velocity of Flow at $Q_P$ $V$ m/s	Vertical Clearance				Vertical Clearance Height Total $H_{VC2}$ $=H_{SD}+H_{DF}+H_{DC}+H_{FB}$ m
				Sediment Deposit Depth $H_{SD}$ M	Flood-flow Height $H_{FF}$ m	Clearance of Debris-flow $H_{DC}$ m	Free Board at $Q_{DF}$ $H_{FB}$ m	
Ghyampe	409	7	7.8	1.0	1.3	1.0	1.5	4.8
Mamti	359	6	7.0	1.0	1.3	1.0	1.5	4.8
Bhyakure	431	4	6.6	1.0	1.6	1.0	1.5	5.1

Source: JICA Expert Team

(2) Specific Energy Head (Case-3)

The vertical clearance of bridge is cross-checked with the specific energy (E) of flow to design the bridge for safety.

Specific Energy (E) is the sum of potential energy i.e. flow depth (H) and kinetic energy i.e. velocity head ( $V^2/2g$ ) computed considering flood flow discharge ( $Q_P$ ).

$$E = y + V^2/2g \text{ --- Specific Energy Head}$$

Where,

$E$  = Specific energy head (m)

$y$  = Flow water depth of  $Q_P$  (m)

$V$  = Velocity of flow at peak flood-flow of  $Q_P$  (m/s)

$g$  = Acceleration due to gravity 9.81 (m/sec<sup>2</sup>)

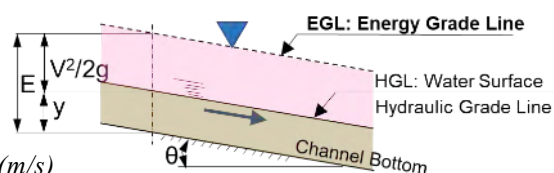

In Table 5-26 (Case-1), the head due to the specific energy from the riverbed has not been considered while calculating the clearance required for the bridge. It is advisable to consider the specific energy level also. However, the total head at bridge site based on the Specific Energy formula has been calculated considering as flood flow discharge ( $Q_P$ ) and presented in Table 5-28.

Table 5-28 Calculation of Vertical Clearance Case-3, Specific Energy Head

Bridge Opening = 38.0m

Tributary	100-year Return Period Flood-flow $Q_P$ m <sup>3</sup> /s	Design Riverbed Slope $S$ %	Velocity of Flow at $Q_P$ $V$ m/s	Vertical Height		Vertical Clearance of Specific Energy $E = y + V^2/2g$ m
				Flood-flow Height $y$ m	Velocity Head $V^2/2g$ m	
Ghyampe	409	7	7.8	1.3	3.7	5.0
Mamti	359	6	7.0	1.3	3.0	4.3
Bhyakure	431	4	6.6	1.6	2.7	4.3

Source: JICA Expert Team

(3) Determination of the Vertical Clearance Height

The planned bridge heights will be determined by the minimum vertical clearance height under the bridge are shown in Table 5-29.

Table 5-29 Summary of Vertical Clearance by Linear Waterway at HFL and Specific Energy

Tributary	General Parameters			Various case of Vertical Clearance Height			Adopted Vertical Clearance Height m
	$Q_P$ m <sup>3</sup> /s	Design Riverbed Slope %	Velocity of Flow at $Q_P$ m/s	At Linear Waterway HFL		Specific Energy Head m	
				Case-1 Passing Debris-flow m	Case-2 Deposition Debris-flow m		
Ghyampe	409	7	7.8	5.0	4.8	5.0	5.0
Mamti	359	6	7.0	4.9	4.8	4.3	4.9
Bhyakure	431	4	6.6	5.6	5.1	4.3	5.6

Source: JICA Expert Team

## 5.8 Determination of Scour Depth

Scouring can be defined as a process due to which the particles of the soil or rock around the abutment or pier of the highway bridge gets eroded and removed over a certain depth by flood water is called scour depth. Scouring usually occurs when the velocity of the flood water increases or crosses the limiting value that the soil particles can bear. Scour occurs whenever hydrodynamic bottom shear stress is greater than the sediment critical shear stress. An accurate estimation of scour depth below stream-bed during design is important since this determines the foundation levels of the bridge's structures such as pier, abutment, guide bank, spur, etc.

### 5.8.1 Selection of size of bed materials, approach and findings

In order to determine the scour depth, one of the important aspects is to select the particle sizes of the bed materials in the river. The prevailing sizes of bed materials depends on many characteristics related to the river including the river gradient, type of rocks of catchment, vegetation coverage pattern and so forth.

The particle size distribution curve of the bed materials can be prepared by Sieve analysis method and the sizes of different particles with their weightage percentage can be determined. But, as an alternative method. A very rough distribution can be made by image analysis up to some satisfactorily extent for preliminary design purpose. Validation of these analysis is required through proper sieve analysis.

#### 1. Image Analyses

Approach: A square window of size 1.0m x 1.0m was laid at some undisturbed part of riverbed. Photographic images were taken from good resolution camera holding at a vertical point covering the window. The image was inserted and matched exactly at the grid of 1000mm x 1000mm in a file of GIS software. Each discrete particle was identified. Delineation of these particles were made correctly, and polygon were drawn with defined Id. No. The area of the polygon is automatically generated as shown in Figure 5-12 below.

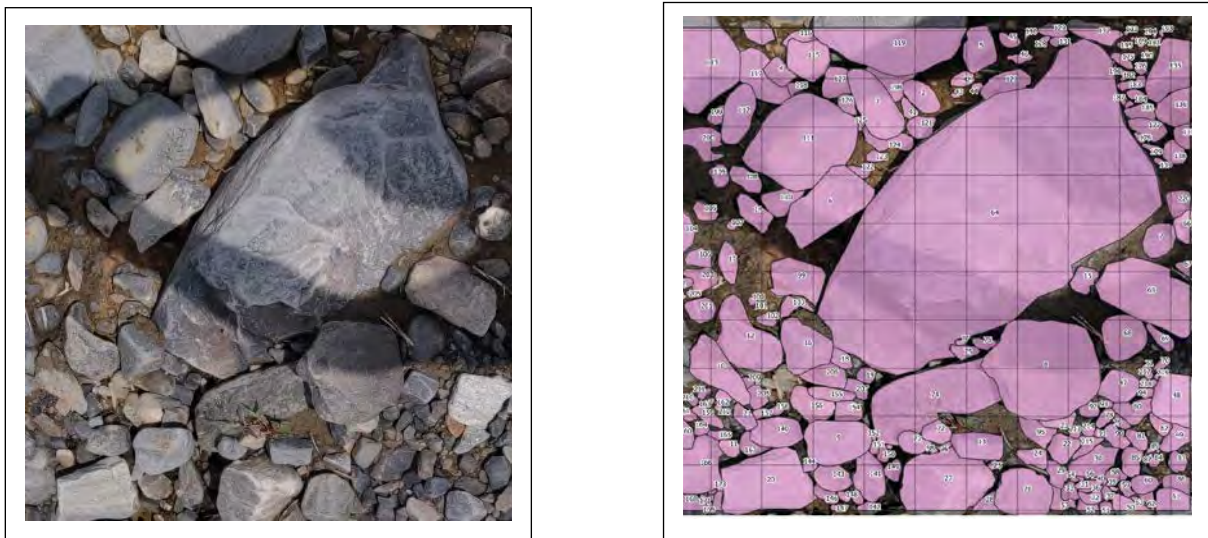

Figure 5-10 Image Analysis for Sieve Grading

Based on the area of polygons, the weight of the particles has been calculated assuming these area as the area of equivalent circle and converted them to the spheres of the same diameter. The weights are sorted from higher to lower order and their cumulative percentage as well as the passing percentage value. The size of the spheres (equivalent diameter) versus their passing percentage has been plotted in the graph at semi-logarithm scale for all three rivers separately.

Limitations: while analyzing the particle size distribution by images, the following limitations need to be considered (which have not been considered in the sampling)

- the bed materials at the surface are at the time of recessed flow, it may be of smaller sizes than that of high flood time, so the representing particles may be of lower side

- there are many big boulders observed in the bank brought by the flood which have not been incorporated in the image, so the representing particles may be of lower side
- the selection of sample by 1.0 x 1.0 m window is decided by person to person, so may deviate somehow from the true sampling
- during converting weight of the particles from the polygons for analysis, the equivalent diameter has been assumed considering regular spheres, which do not represent the irregular shape of particles in real condition, therefore the assumed equivalent size of diameter is in the higher side. Apart from that, there is some error associated while assuming of diameter and square holes (sieve holes are square).

The graph prepared for Ghyampe tributary has been presented below in Figure 5-13 as a representative graph. All three graphs are presented in Annex-5.

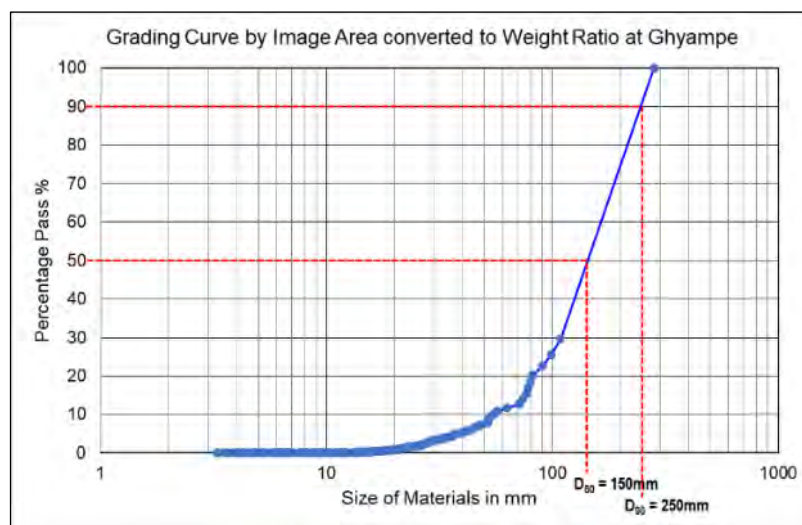

Figure 5-11 Representative Graph of Image analysis of Particle Size Distribution at Ghyampe

2. Sieve Grading by Field Verification

JICA Expert Team has hired one Contractor to conduct Geotechnical Investigation Works of proposed bridge sites under Pilot Projects (Please refer Section 3.4 above) with designated scope of works as mentioned there on. One of the Scope of works was to determine sieve grading test analysis (D<sub>50</sub> and D<sub>90</sub>) from the proposed three (3) bridge sites. Accordingly, the Contractor executed the sieve grading test analysis (D<sub>50</sub> and D<sub>90</sub>) and submitted the results (see Annex-4). The Summary of finding out of sieve analysis test analysis (D<sub>50</sub> and D<sub>90</sub>) is presented in the Table 5-30 below.

Table 5-30 Determination of D<sub>50</sub> and D<sub>90</sub> Size Particles (Sieve Analysis at field)

S.N.	Tributary	D <sub>50</sub> size in (mm)			D <sub>90</sub> size in (mm)		
		Image Analysis	Sieve Grading	Applied for Analyze	Image Analysis	Sieve Grading	Applied for Analyze
1	Ghyampe	150	175	150	250	320	200
2	Mamti	150	151		190	318	
3	Bhyakure	160	149		203	331	

Source: The JICA Expert Team

5.8.2 Equations for Scour Depth Estimation

Scour is the depth created around the bridge abutments, piers, bank protection structures, etc. on riverbed due to taking away the bed materials because of erosive action of flood flows.

The scouring depth are analyzed by IRC:5-1998 and 78-2014 and other two (2) alternative regime equations for general scouring described in H10, Hydrological Manual for Infrastructures as below;

1. Case-1 Lacey’s Regime Equation (1930) stipulated in Clause 110.1.3., IRC:5-1998, IRC:78-2014
2. Case-2 Farraday and Charlton Equation

## 3. Case-3 Blench Equation (1969)

## (1) Case-1 Scour Depth Calculation by Clause 703 of IRC:78-2014

Clause 703 of IRC:78-2014 and Clause 110.1.3 of IRC:5-1998 explain the conditions regarding the determination of scour depth for foundation design. Where the variation of water-surface level with flow rate is known, Neill (1973) indicates that bed levels can be determined for a bridge site on an uncontracted alluvial river based on the Lacey's regime formula (1930).

As per Clause 703.1.1, IRC:78-2014, the design discharge for adequate margin of safety, the scour for foundation design to be increased by 30% in addition for the river having catchment area less than 3000 km<sup>2</sup> as below.

Catchment area (km <sup>2</sup> )	Increase over design discharge (%)	Adopted increase over design discharge
0 ~ 3000	30 %	30% increase $Q_{F1.3}$
3000 ~ 10000	30 - 20 %	
10000 ~ 40000	20 - 10 %	
Above 40000	10 %	

Source: 703.1.1, IRC: 78-2014

Based on above increase over design flood discharge ( $Q_{F1.3} = 1.3Q_P$ ) for safety of scour for foundation, flow water depth and velocity for Ghyampe, Mamti and Bhyakure rivers have been calculated and presented in the Table 5-31 below. These flow depth and velocity will be used in "Case-2 Scour Depth Calculation by Farraday and Charlton Equation".

Table 5-31 Calculation of Flow Water Depth at Adequate Margin of Safety by Manning's Equation for flow conditions ( $Q_{F1.3}=1.3Q_P$ ) for design

Tributary	General Parameters			Hydraulic Parameters of Channel by Manning's Equation									
	$Q_P$ m <sup>3</sup> /s	$C_D$ -	$Q_{F1.3}$ = $C_D Q_P$ m <sup>3</sup> /s	n	Bed slope S %	Z=B/ H -	Side Slope b:1 m	Flow Depth $y_{F1.3}$ m	Calculate d Width B m	X-Area m <sup>2</sup>	Velocit y V m/s	Perimet er P m	Hydrau lic radius R m
Ghyampe	409	1.3	532	0.04	7%	24.5	0.5	1.565	38.35	62.49	9.43	42.78	1.46
Mamti	359	1.3	466	0.04	6%	26.0	0.5	1.500	38.99	60.73	8.56	43.23	1.40
Bhyakure	431	1.3	560	0.04	4%	20.5	0.5	1.895	38.85	77.22	7.91	44.21	1.75

For purely alluvial streams which are contracted beyond Lacey's regime waterway width (W) at the bridge site, the value of Lacey's scour depth ( $D_N$ ) may be computed by using the below formula.

**Boulder strata:** There is no rational method to assess scour in boulder strata of boulders or pebbles. If, say, average size of pebbles is m. (Source: H10, Hydrology Manual for Roads & Bridges)

The basic equation of Lacey's regime waterway at boulder strata is;

*Lacey's Regime Condition for Scour in Boulder Strata: Mean scour depth*

$$R_s = 1.34 (q^2/f)^{1/3} \text{ for Lacey's Regime Condition in Boulder Strata --- IRC:78-2014}$$

Where,

$Q_P$  = Peak flood discharge at 100 years return period (m<sup>3</sup>/s)

$Q_{F1.3}$  = 30% increased design discharge at 100 years return period for foundation (m<sup>3</sup>/s) by Clause 703.1.1, IRC: 78-2014

$R_s$  = Mean scour depth by Lacey's regime condition =  $1.35(q^2/f)^{1/3}$

$q$  = Discharge intensity = (Design discharge  $Q_{F1.3}$ / width of river L) (m<sup>3</sup>/s/m)

$f$  = Silt factor =  $1.76\sqrt{m}$

$m$  = Size of bed materials in mm, 50% materials are smaller (mm)  $D_{50}$

**Scour in sand or clay:** Scour in clay is generally less than scour in sand. Normally in field we get a mixture of sand and clay at many places. For the purpose of assessment following definition of sand and clay can be given. (Source: H10 Hydrology Manual for Roads & Bridges)

Lacey’s Regime Condition for Scour in Sand or Clay: Mean scour depth

$$R_s = 1.34 (q^2/K_{sf})^{1/3} \text{ for Lacey’s Regime Condition in Sand Strata}$$

$$R_s = 1.34 (q^2/K_{sfc})^{1/3} \text{ for Lacey’s Regime Condition in Clay Strata}$$

Where,

- $Q_P$  = Peak flood discharge at 100 years return period ( $m^3/s$ )
- $Q_{F1.3}$  = 30% increased design discharge at 100 years return period for foundation ( $m^3/s$ )
- $R_s$  = Mean scour depth by Lacey’s regime condition =  $1.35(q^2/f)^{1/3}$
- $q$  = Discharge intensity = (Design discharge  $Q_{F1.3}$ / width of river  $L$ ) ( $m^3/s/m$ )
- $K_{sf}$  = Silt factor Sand =  $1.76\sqrt{m}$  Where  $\phi$  is equal to or more than  $15^\circ$  even if  $c$  (Cohesion of soil) is more than  $0.2 \text{ kg/cm}^2$
- $K_{sfc}$  = Silt factor Clay =  $F(1+\sqrt{c})$  :  $c$  = Cohesion in  $\text{kg/cm}^2$  and  $F = 1.5 \phi$  for  $\phi \geq 10^\circ < 15^\circ$ ,  
=  $1.75$  for  $\phi \geq 5^\circ < 10^\circ$ , =  $2.0$  for  $\phi < 5^\circ$
- $m$  = Size of bed materials in mm, 50% materials are smaller (mm)  $D_{50}$

In Clause 703.2.2 of IRC:78-2014, the value of silt factor “ $K_{sf}$  and  $K_{sfc}$ ” for various grades of sandy bed given below for ready reference and adoption.

Type of bed material	Weighted mean diameter of particle : m (mm)	Value of silt factor f at $D_{50}$
Coarse silt	0.004	0.35
Silt/fine sand	0.081 to 0.158	0.5 to 0.7
Medium sand	0.233 to 0.505	0.85 to 1.25
Coarse sand	0.725	1.50
Fine bajiri and sand	0.988	1.75
Heavy sand	1.29 to 2.00	2.00 to 2.42

Source: Clause 703.2.2.1 of IRC:78-2014

For constriction of regime condition at for scour in boundary strata

Normal Scour Depth

$$D_N = R_s (W/L)^{0.61}$$

Where,

- $D_N$  = Normal scour depth below HFL, the Lacey’s regime scour depth (m)
- $R_s$  = Lacey’s regime condition at mean scour depth
- $W$  = Lacey’s regime waterway width (m)  $B = 4.75\sqrt{Q_{F1.3}}$
- $L$  = Contracted width (m) = the width of the stream at the bridge site

Maximum depth of scour in a straight reach =  $1.27 \times D_N$

Flood without seismic combination for Abutments having individual foundations without any floor protection, Clause 703.3.1.1 of IRC:78-2014

Based on above condition, the maximum scour depth for Ghyampe, Mamti and Bhyakure rivers in boundary strata have been calculated and presented in Table 5-32 below.

Table 5-32 Scour Depth Calculation by IRC:78-2014

Tributary	General parameters			B=W	L	m	f	$R_s$	Normal $D_N = R_s (W/L)^{0.61}$	Maximum depth of scour below from HFL $1.27 \times D_N$
	$Q_P$	$C_D = Q_{DF}/Q_P$	$Q_{F1.3}$							
	$m^3/s$		$m^3/s$	m	m	mm			m	m
Ghyampe	409	1.3	532	109.6	40	150	21.6	2.70	5.0	6.4
Mamti	359	1.3	467	102.6	38	150	21.6	2.56	4.7	6.0
Bhyakure	431	1.3	560	112.4	40	150	21.6	2.79	5.2	6.6

Source: JICA Expert Team

(2) Case-2 Scour Depth Calculation by Farraday and Charlton Equation

The basic equation of Farraday and Charlton at gravel bed channel is;

Farraday and Charlton Equation at Gravel Bed Channel

$$Y_2 = 0.47(V_1 Y_1)^{0.8} \times (D_{90})^{-0.12}$$

Where,

$Y_2$  = Average depth of general Scour measured from the water surface (m)

$V_1$  = Mean design flow velocity (m/s)

$Y_1$  = Design depth equal to  $(A_1/T_1)$  in m,  $T_1$  Surface width in m,  $A_1$  = Area of flow ( $m^2$ )  
 $V_1$  and  $Y_1$  are estimated based on  $Q_{F1.3}$ : 30% increased design discharge at 100 years return period for foundation ( $m^3/s$ )

$D_{90}$  = Size of bed materials in mm, 90% materials are smaller (mm)

Max. depth of scour in a straight reach =  $1.27 \times Y_2$  Clause 703.3.1.1 of IRC:78-2014

Since, the survey of finding of  $D_{90}$  is ongoing at the field. The calculation of scour from this equation is made for many values of  $D_{90}$  for comparison, as presented in Table 5-33 below.

Table 5-33 Scour Depth Calculation by Faraday and Charlton Equation

Tributary	General Parameters			Flow Depth $Y_{F1.3}$ m	Velocity $V_1$ m/s	$D_{90}$ mm	Average $Y_2$ (Gravel) m	Maximum depth of scour below from HFL $1.27Y_2$ m
	$Q_P$ $m^3/s$	$C_D = Q_{DF}/Q_P$ -	$Q_{F1.3}$ $m^3/s$					
Ghyampe	409	1.3	532	1.6	9.43	200	4.8	6.0
Mamti	359	1.3	467	1.5	8.56	200	4.4	5.6
Bhyakure	431	1.3	560	1.9	7.91	200	5.0	6.3

Source: JICA Expert Team

Other cases of bed of channel such as “sand bed channel”, and “cohesive bed channel” shall be referred to the H10 Hydrology Manual for Roads & Bridges.

(3) Case-3 Scour Depth Calculation by Blench Equation

The mean scoured flow depth, below the surface can be determined based on the mean discharge per unit channel width as Blench Equation.

The basic equation of Blench at gravel bed channel is;

Blench Equation

$$Y_2 = (q^2/F_b)^{0.33}$$

Where,

$Y_2$  = Average depth of general scour measured from the water surface (m)

$q$  = Average design unit discharge adjacent to the subject section  $Q_{F1.3}$ / width of river L ( $m^3/s/m$ )  
 $Q_{F1.3}$ :30% increased design discharge at 100 years return period for foundation ( $m^3/s$ )

$F_b$  = Blench ‘Zero bed factor’ from figure given below in Figure 5-13 (m/s)

Max. depth of scour =  $1.50 \times Y_2$  (Multiple Factor 1.50~2.0)

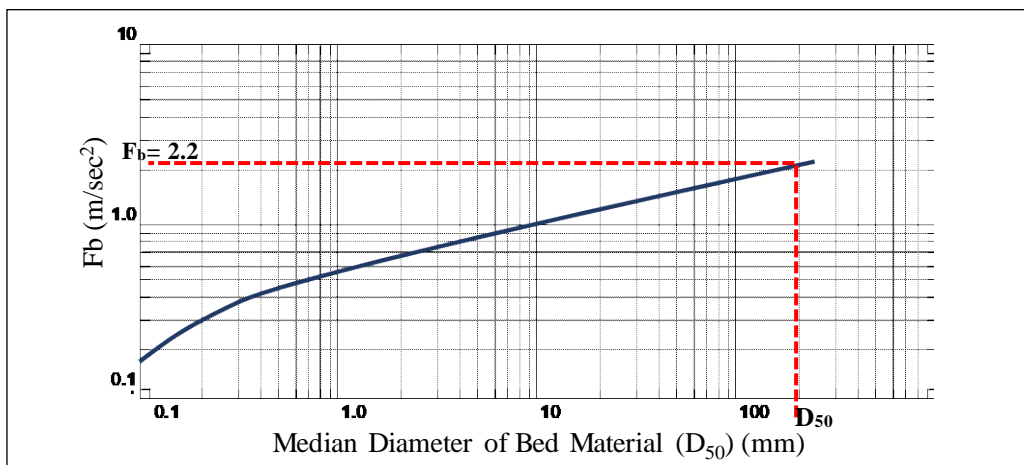

Figure 5-12 Blench  $F_b$  “Zero bed factor”

The calculation of scour from Blench equation is made for many values of  $D_{50}$  (and hence  $F_b$ ) for

comparison and presented in Figure 5-14 above and Table 5-34 below.

Table 5-34 Scour Depth Calculation by Blench Equation

Tributary	General Parameters			L m	$q = Q_{F1.3}/L$ m <sup>3</sup> /s/m	D <sub>50</sub> mm	Zero Bed Factor F <sub>b</sub> m/sec <sup>2</sup>	Average Y <sub>2</sub> m	Maximum depth of scour below from HFL 1.50Y <sub>2</sub> m
	Q <sub>P</sub> m <sup>3</sup> /s	C <sub>D</sub> = Q <sub>DF</sub> /Q <sub>P</sub> -	Q <sub>F1.3</sub> m <sup>3</sup> /s						
Ghyampe	409	1.3	532	40	13.30	150	2.2 <sup>*1</sup>	4.6	6.4
Mamti	359	1.3	467	38	12.29	150	2.2	4.0	6.1
Bhyakure	431	1.3	560	40	14.00	150	2.2	4.2	6.6

\*1: F<sub>b</sub> "Zero bed factor" for D<sub>50</sub> mm is read from above graph.

Source: JICA Expert Team

### 5.8.3 Adoption of Scour Depth

The maximum of scours depth calculated above have been adopted for the design. The minimum depth of open foundation for Ghyampe and Bhyakure shall be up to stratum having safe bearing capacity but not less than 2.0 m below the scour level (stated in IRC: 78-2014 Clause 705.2). Mamti is designed by RC continuous Slab with raft foundation, in case of the raft foundation not required additional embedded depth up to stratum. Scour depth need not be increased by any factor as in case of open foundations as stipulated in IRC:78-2014, Guidelines for the Design of Small Bridges and Culverts, IRC: SP13-2004.

The Scour depth by all three equations mentioned above are summarized in Table 5-35 and presented below. The highest of these values obtained from the combination of methods should be adopted as the design scour depth.

Table 5-35 Summary of Scour Depths by Various Equations and Footing Embedded Depth

Tributary	Parameters		Various Scour Depth Calculation			Scour depth + Water depth m	Scour depth d/s bed – bottom of foundation m	Additional embedded depth for open foundation m	Required scoured depth m
	Q <sub>adopted</sub> =Q <sub>F1.3</sub> m <sup>3</sup> /s	Water depth above bed y <sub>F1.3</sub> m	IRC:78- 2014 Lacey's m	Faraday and Charlton equation m	Blench equation m				
	Ghyampe	532	1.5	6.4	6.0				
Mamti	467	1.4	6.0	5.6	6.1	6.1	4.7	0.0	<b>4.7</b>
Bhyakure	560	1.9	6.6	6.3	6.6	6.6	4.7	2.0	<b>6.7</b>

Source: JICA Expert Team

Scour around bridge pier is the main reason for the failure of bridges. The local scour around the pier causes exposure of the foundation and may lead to undermining of the structure. One of the possible effective bridge scour protection measures is to provide a raft foundation with cut-off walls.

### 5.8.4 Determination of the Bridge Structure Dimensions

Required height and design height of the bridges are summarized in Table 5-36 below.

Table 5-36 Summary of the Bridge Structural Dimension

Bridge	Bridge Length m	Super-structure (Girder) height m	Hydraulic design result			Structure height		Bridge design	
			Required Vertical clearance m	Required Scour depth upto the bottom of foundation m	Diff. of bed level at u/s and d/s m	Min. required calculated height m	Foundation height m	Structure total height m	Inner opening height m
Ghyampe	40	3.0	5.0	6.9	0.77	15.67	2.0	16.0	11.0
Mamti	40	1.1	4.9	4.7	0.66	11.36	1.6	12.0	9.3
Bhyakure	40	3.0	5.6	6.7	0.44	15.74	2.0	16.0	11.0

Source: JICA Expert Team

Determined type of bridge and foundation for three causeways are;

Ghyampe bridge: PC Post Tension 2-webbed cis bridge with 40m single span + Open foundation

Mamti bridge: RC continuous Slab bridge 40m length + Raft foundation

Bhyakure bridge: PC Post-tension 2-webbed cis bridge with 40m single span + Open foundation

## 6 Conceptual Design of Bridge for Restoration of Causeway (Alternatives)

### 6.1 Conceptual Design of Bridge

Several alternatives have been proposed as Conceptual Design of Bridge for Restoration of damaged Causeway and the list is presented in the Table 6-1 below.

Table 6-1 Alternative List of Bridge Type

Type of Bridge	Deck Slab type/ Erection method	Adoptable Bridge Length			Characteristic							Applicable Span Length (m)					
		Adopt. Span	Girder/ Deck Height	Girder Height/ Span Ratio	Experience in Nepal contractor	Nepal Standard Drawing	Adoptable for the flat area	Reduce the structure height	Required heavy track crane	Required high framework for heavy girder	Procurement of material	10	20	30	40	50	60
		L (m)	H <sub>G</sub> (m)		⊙	⊙	⊙	⊙	⊙	⊙	⊙						
Concrete	RC Slab (Simple)	All staging	4 ~ 10	0.5 ~ 0.9	1/8~11	⊙	⊙				Δ	○					
	RC Continuous Slab	All staging	7 ~ 15	0.8 ~ 1.1	1/9~14	⊙		⊙			Δ	○					
	RC T-Girder	All staging	15, 20, 25	1.5 ~ 2.5	1/10	⊙	⊙	Δ			Δ	○					
	PC Slab	All staging	15	0.8	1/19	○	○	⊙			Δ	○					
	PC Voided Slab	All staging	20 ~ 30	1.0 ~ 1.6	1/20	-	○	⊙			Δ	Δ					
	PC T-Girder (2 webs)	All staging	30, 35, 40	2.4 ~ 3.0	1/13	⊙	⊙	Δ			Δ	○					
	PC T-Girder (3 beams)	All staging	30 ~ 40	2.2 ~ 2.8	1/14	⊙	⊙	Δ			Δ	○					
	PC I-Girder (5 girders)	Track crane	30 ~ 40	2.2 ~ 2.5	1/14~16	○		Δ	○	Δ		○					
	PC Box Girder (1 cell)	All staging	40 ~ 60	3.0 ~ 4.5	1/13	○		Δ			Δ	○					
PC Ribbed Deck	All staging	20 ~ 35	2.0 ~ 2.4	1/10~15	Δ		Δ			Δ	○						
Steel	Steel I Girder (Simple span)	RC (Timbering)	25 ~ 40	1.5 ~ 3.0	1/20	○	○	○	Δ		Δ						
	Steel Box Girder (Simple span)	RC (Timbering)	40 ~ 60	2.0 ~ 2.5	1/22	-		Δ	○	Δ	Δ						
	Truss (Lower RC deck slab)	RC (Timbering)	40 ~ 60	1.0 ~ 1.5	-	○	○	⊙	Δ		Δ						

Source: JICA Expert Team

Several alternatives have been proposed as conceptual design of bridge for restoration of damaged causeway as presented in the following illustrations in Table 6-2 and Table 6-3.

Table 6-2 Illustration of Alternatives





Description	Superstructure Cross Section	Elevation View
<p>Alternative – A</p> <p>PC Post Tension 2-Webbed cis Bridge</p> <p>All staging</p> <p>Single Span 40m</p> <p>Reverse T-shape RC Abutment x 2</p>		
<p>Alternative – B</p> <p>PC Post-tensioned Precast Multi-girder Bridge</p> <p>Erection by Track crane</p> <p>Single Span 40m</p> <p>Reverse T-shape RC Abutment x 2</p>		
<p>Alternative – C</p> <p>PC Post-tensioned Void Slab Cast-in-situ on all staging</p> <p>Single Span 2 x 20m</p> <p>Reverse T-shape RC Abutment x 2 T-beam Column Pier</p>		
<p>Alternative – D</p> <p>RC Continuous Slab Cast-in-situ on all staging</p> <p>Continuous Span 12 + 16 + 12m = 40m</p> <p>End and Mid-wall on Spread Bottom Slab</p>		
<p>Alternative – E</p> <p>Steel Truss with Lower RC Deck Slab</p> <p>Single Span 40m</p> <p>Reverse T-shape RC Abutment x 2</p>		

Table 6-3 Comparison among Various Alternative Bridges of Restoration of Causeway

Alternative	Alternative-1	Alternative-2	Alternative-3	Alternative-4	Alternative-5
Bridge Type	PC Post Tension 2-webbed cis Bridge	PC Post Tension Precast Multi-girder Bridge	PC Post Tension Void Slab cis Bridge	RC continuous Slab cis Bridge	Steel Truss with Lower Deck Slab
1. Superstructure Structural Condition	Post-tension T-girder (construct on all staging) is applied for the span of 30, 35 and 40m by the Typical Standard Drawings designed by DOR bridge construction project in Nepal. Economical height of the cast-in-situ T-girder will be higher than I-girder, so elevation will raise. ○	Post-tension I-shaped precast girder erection by track cranes is applied for the economical span of 30 ~ 40m. Number of I-girders shall be increased to minimize the height of girder. However total weight of superstructure and cost will be increased. ○	Post-tension PC Voided Slab is applied for the span of 20 ~ 30m. Void slab made of PC or RC are one of effective method to reduce the height of superstructure of the bridge. ○	RC un-equal length of three (3) span of Continuous Slab is applied for the total length of around 35 ~ 40m. Wide opening of the center span is an advantage for smooth passing debris flow compared with even number of span bridge. ◎	Single span of Steel Truss is applied for the span of 40 ~ 60m length. △
2. Construction Condition	Post-tension PC T-girder is fabricated and stressed on the all staging of the falsework at the construction site. Construction of the superstructure on the all staging is adopted to construct at the limited construction area. ◎	Post-tension Precast I-girders are fabricated and stressed in the wide area of yard near the bridge site shall be secured at debris/flood flow area in alluvial fan. Precast girders are erected by two heavy track cranes more than 80ton, hired from India. △	PC Post-tensioned Void Slab is fabricated and stressed on the all staging of the falsework at the limited area of construction site. Cylinder void pipe made of carbon or steel plate or Styrofoam shall be imported from Japan or third countries. △	RC Slab is fabricated and stressed on the all staging of the falsework at the limited area of construction site. False work for all staging for fabrication of slab or girder is a popular construction method without heavy equipment. ◎	Trussed members are erected by track crane and bent supports. ○
3. Substructure Condition	As Spread Footing is installed below the deep depth (2m) of opening for debris flow, abutment is not affected by local scoring due to flood (water) flow. Abutment height will be around 15m, as large earth pressure forces to the body, the spread foundation showing a tendency to increase. ○	As Spread Footing is installed below the deep depth (2m) of opening for debris flow, abutment is not affected by local scoring due to flood flow. Abutment height will be around 15m, as large earth pressure forces to the body, the spread foundation showing a tendency to increase. ○	Same condition as left side alternative. Independent pier at the main stream of the water course shall be required geotechnical investigation and shall be study for requirement of pile or well foundation. △	Substructure is made of both end and mid walls on the continuous bottom slab. Stability against the earth pressure of the end wall and bearing stratum is high ◎	As Spread Footing is installed below the deep depth (2m) of opening for debris flow, abutment is not affected by local scoring due to flood (water) flow. Abutment height will be around 15m, as large earth pressure forces to the body, the spread foundation showing a tendency to increase. ◎

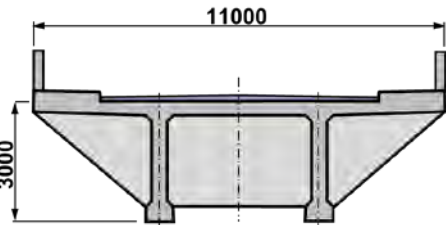
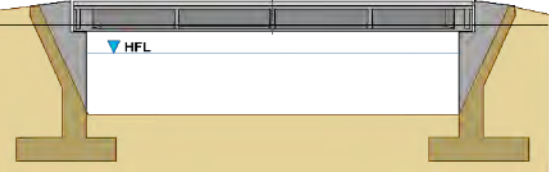
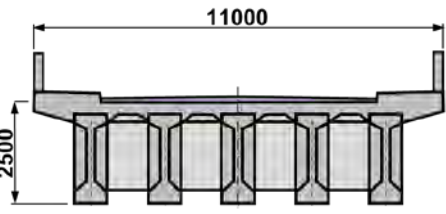
4. Hydrology Characteristics	Single span with wide opening without pier in the river course is advantage for the debris/flood flow of the tributary. ◎	Single span with wide opening without pier in the river course is advantage for the debris/flood flow of the tributary. ◎	Independent foundation pier located at the center of the opening of bridge is obstacle the water course. △	Wide opening of the span at the center of the water course under superstructure is good at hydrological reason. ◎	◎
5. Procurement of Material and Erection/Casting	Very high compressive strength concrete M45 (by cube mold) shall be mixed at remote area & on staging. △	Very high compressive strength concrete M45 by cube (around 35N/mm <sup>2</sup> by cylinder) is required at remote area, small amount. △	Very high compressive strength concrete M45 by cube (around 35N/mm <sup>2</sup> by cylinder) is required. △	Top slab concrete will be M35 by cube (around 30 N/mm <sup>2</sup> cylinder) ○	Track crane and bents are required for fabrication at the site. ○
6. Environmental Aspects	Road level at bridge shall be raising around 2m height above the existing road level. It will be much affected surrounding house, facilities and access road. High death of girder above the existing road level will give discomfort and ugly view to the surrounding residents and villagers. △	Road level at bridge shall be raising around 2m height above the existing road level. It will be much affected surrounding house, facilities and access road. High death of girder above the existing road level will give discomfort and ugly view to the surrounding villagers. △	Road level at bridge shall be raising around 1m height above the existing road level. It will be much affected surrounding house, facilities and access road. ○	Existing road (floodway) level will not raising. ◎	Steel trussed structures such as chord and diagonal members above the deck and existing road level will cause a heavy bad impact to the surrounding residence and driver running the bridge. X
7. Maintenance	Maintenance of bridge is not necessary exception of cleaning of drain, expansion joint, bearing and incidentals. ○	Maintenance of bridge is not necessary exception of cleaning of drain, expansion joint, bearing and incidentals. ○	Maintenance of bridge is not necessary exception of cleaning of drain, expansion joint, bearing and incidentals. ○	Reinforced concrete structure slab and simple shape of mid wall have advantage to maintenance or repair wok damaged by debris. ◎	It is required to inspect and maintenance periodically for the painting and expansion joints by movement of the steel body. △
8. Technical Transfer Aspects	DOR has standard drawings for PC-T (span 30, 35, 40m), RC-T (15, 20, 25m) and RC Slab (4~10m) ○	New concept of PC bridge with low height girder. However, heavy equipment in Nepal is limited. ○	New technology and concept of the bridge design in Nepal. However, void pipe is required to import from other country. ○	Concept is adopted for tributary with debris/mud flow, wadi river and low discharge river in lower current area in Terai plain. ◎	Truss bridge with dual lane and both side foot path is constructed in wide river with big water. △
9. Economical Aspects	Concrete bridge is reasonable to use natural resources mainly. Trustable quality Anchor and PC strand for post-tension devise shall be imported from India. ○	Concrete bridge is reasonable to use natural resources mainly, however heavy crane shall be required. Trustable product for PC & devise shall be imported from India △	Material for void in concrete slab shall be procured from Japan or other country. Structure is good at using river in city. △	Reinforced concrete bridge is reasonable to use natural resources mainly. Cast-in-situ concrete on the falsework at the erection site is reasonable method without heavy equipment. ○	Import steel material and fabrication cost of the steel truss for wide lane bridge is extremely high compared with concrete bridges mainly consists of local product material. △
Overall Evaluation	Wider opening under the girder against debris flow ◎	△	△	Recommended Reasonable opening for debris flow and cost ◎	Steel structure is not reasonable for high cost and imported material from third countries. △

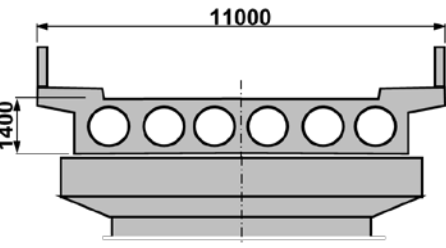
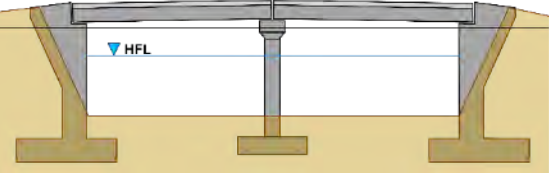
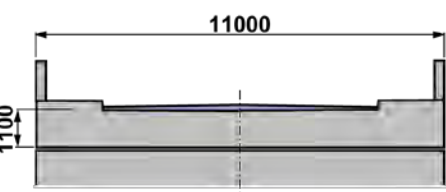
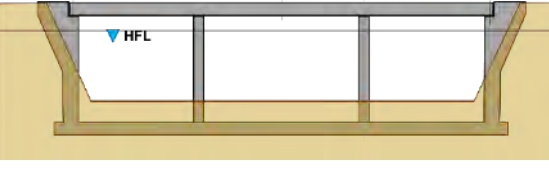
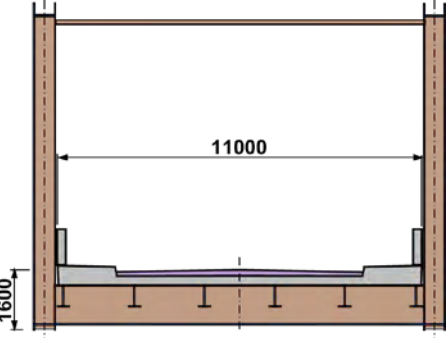
◎: Very Good

○: Moderate

△: Poor

X: NA

## 6.2 Conclusions

### 6.2.1 Conclusion based on Hydrological, Hydraulics, Social and Financial Condition

The following conclusions are drawn after analyzing the normal and debris flow of 100-year return period in the tributaries.

- a) Normal flood flow of 100-year return period of the tributaries can pass safely from 38 m wide around 6 m high bridge. But river training and high revetment work around the bridge are necessary at upstream and downstream part of the bridge for channelizing the flood water within the width of bridge.
- b) Over more these channelized bed stream shall be uniform to adjust present stable slope at downstream part of each road crossing without occurrence scour or sedimentation by hydraulic jump.
- c) Debris flow of 100-year return period of the tributaries can pass from 38 m wide and around 5.0~6.0 m clearance high bridge. In this case velocity of flow becomes quite high which may damage abutments of the bridge and river bank protection works due to scouring and bank cuttings. Therefore, quite strong foundation of the bridge abutments, bed slab and river bank protection structures should be constructed.
- d) Debris flow of 100-year return period of the tributaries can pass safely through the bridge width.
- e) However, in all alternatives, a proper river training work at upstream part of the bridge is necessary for channelizing the flood water into the bridge, otherwise flood water overflows from left and right sides of the bridge during heavy floods and it damages the bridge and the highway.
- f) Excavation of sediments deposited on upstream part of the causeway to make inlet of flood water to pass through the bridge increases the velocity of flood water tremendously and causes scouring and riverbank cuttings problems, so proper countermeasures for this is required.
- g) Having the soils of river area and banks loose and fragile, the open foundation of bridge abutments and raft foundation and riverbank protection structures should be at deeper depths and stronger to protect the structures from impact energy of debris and high velocity of flood water.

### 6.2.2 Conclusion on Selection of Type of Bridges

Considering the existing riverbed slopes obtained from the measurement each tributary as per topo survey recently conducted by the JICA Expert Team has been, the water way has been fixed as 38m wide. Depending on the characteristics and size of catchment area, as explained in previous chapters, the highest required vertical clearance is calculated above, accordingly a minimum of 6.0m clearance is required.

Therefore, Bridge having length of 40m with different height mentioned above have been preliminarily selected.

A comparison between RC continuous Slab Bridge (Alternative-4) and PC Post-tensioned Bridge by single span (Alternative-1) has been done and presented in Table 6-4 below.

Table 6-4 Evaluation of the Proposed Type of Bridges

SN	Description	RC continuous Slab Bridge (Alternative-4)	PC Post-tension 2-webbed Bridge (Alternative-1)
1	Span	Continuous 3 span 12m+16m+12m	Single span, 40m
2	Debris pass	Likely hit to the piers, which required to cast jacketing u/s side of inner walls	Safe without pier(s) in river course
3	Foundation	Bottom Raft as bed slab required, Stable on alluvial fan area Easy in Construction	Required geotechnical investigation of bore hole for independent foundation of abutment
4	Top slab thickness	Deck slab thickness t=1.1 m	3 m height at 2-webbed (Typical Standard)

			Drawing) with 40m span
5	Approach connection	Easy and safe	Difficult because of Extra height
6	Social Impact	Adjacent houses	Less effect by embankment
	Land acquisition	Less effect by embankment	More effect by embankment
7	Revetment	Required around high abutment	Required around high abutment
8	River bet protection for Scouring	Required around Bed Slab	Required around Abutments' Foundation
9	River training	Less requirement	More due to higher embankment
10	Experience	Many similar structures were built in Sindhuli Road area	Some Bridges were built in Section I
11	Quality of construction	Top slab concrete shall be M35 by cube (30 N/mm <sup>2</sup> by cylinder)	Very high compressive strength concrete M45 by cube (around 35N/mm <sup>2</sup> by cylinder) shall be mixed at remote area with small quantity.
12	Contractors	Many local contractors available	Limited number of local contractors available
13	Cost	Moderate	High for PC post-tensioned bridge constructed at remote area
14	Complexities	Low	High for prestressed concrete casted at remote area
15	Repair & maintenance	Easy for concrete structure	Complex
16	DOR preference	Less	More

Source: JICA Expert Team

After taking into account various aspects, advantages and disadvantages for selecting the type of bridge, the following two types have been selected for final consideration.

- a) RC continuous Slab Bridge (3 spans 12m+16m+12m, Total 40m)
- b) PC Post-tensioned 2-webbed Bridge (Cast-in-situ on all staging, Single span of 40m)

A series of discussion within JICA Expert Team and with Department of Roads (the Sindhuli Road Project and Bridge Branch of DOR), PC Post-tensioned Bridge with single span has been selected for Ghyampe and Bhyakure River. However, because of proximity to Roshi River (about 70m) other constraints due to the site conditions, RC continuous Slab Bridge has been selected for Mamti River. The selection of these bridges has also been endorsed by DOR officials during their visit to these sites.

The determined type of the bridge and structural details are shown in Table 6-5.

Table 6-5 Determined Bridge Type and Structural Details

Bridge	Bridge Type	Structural Details
Ghyampe	PC Post-tensioned 2-webbed Bridge cast-in-situ on all staging	<ul style="list-style-type: none"> <li>- According to the actual condition of the debris flow width of upstream and downstream section and scoured/eroded width of downstream section, 40 m length of bridge is planned.</li> <li>- This length is also decided as same as present (after heavy flood in July 2019) downstream side opening expanded by scouring.</li> <li>- Pier in water stream is not recommendable while the condition of the debris-flow with large sized boulders of 1.0m and condition of the eroded downstream section.</li> <li>- Single span of 40 m is selected as of maximum length of PC girder bridge by cast-in-situ concrete on the all staging method.</li> <li>- Beam number of the PC girder bridge cast-in-situ is two (2) as the most economical and practical for construction.</li> <li>- Abutment type of spread foundation is decided by the result of bore holed investigation.</li> </ul>
Mamti	RC continuous Slab Bridge with outer and inner walls on bed slab	<ul style="list-style-type: none"> <li>- According to the actual condition of the debris flow width of upstream and downstream section 40 m length of bridge is planned.</li> <li>- Raising the road elevation by more than 5m from the existing ground (floodway) might cause inconvenience and negative impacts to the villagers living nearby the site. In such case although as debris-flow passing and stopping section, a RC continuous Slab bridge with inner wall be adopted.</li> <li>- The size of the boulder is 0.5 m in debris-flow, and it is judged from the actual site conditions of the Sindhuli Road that piers (inner wall) can be installed in the river channel.</li> <li>- Span combination is odd number of three and center span will be wider than side ones.</li> <li>- Hinge type joint is applied at connection of superstructure and substructure considering the easy repair.</li> <li>- Movement joint type is selected at the joint of both outer walls and slab to avoid the influence of the horizontal force by earth pressure to other walls.</li> <li>- Inner walls are covered by concrete with wire mesh surrounding for protection</li> </ul>

		of the debris-flow in the stream. - Maximum diameter of the deposit 1m, the average being 0.3m.
Bhyakure	PC Post-tensioned 2-webbed Bridge cast-in-situ on all staging	- According to the actual condition of the debris flow width of upstream and downstream section and scoured/eroded width of downstream section, 40 m length of bridge is planned. - This length is also decided as same as present (after heavy flood in July 2019) downstream side opening expanded by scouring. - Pier in water stream is not recommendable while the condition of the debris-flow with large sized boulders of 1.0m and condition of the eroded downstream section. - All of the determination conditions are same as Ghyampe.

Source: JICA Expert Team

Summary of the Bridge structure are as shown in Table 6-6 below.

Table 6-6 Summary of the Bridge Structure and River Training Works

Bridge	Description	Details	Remarks
Ghyampe	Bridge Length	40m	
	Span arrangement	Single span	
	Superstructure	Cast-in-situ 2-webbed Prestressed Concrete Slab-deck	Bridge type
	Substructure	Inverted T-type abutment	No pier
	Foundation	Open foundation	Bearing capacity for open foundation is decided by the geotechnical survey. Require additional embedded depth 2m for scour.
	Riverbed	Channelized uniform and constant slope	Required deep excavation of ground at upstream side of the bridge
	River training work	Revetment and guide bank	
	Revetment wall	Compound wall	Protection of Abutments
Mamti	Guide bank	Gabion mattress and launching apron	
	Bridge Length	40m	
	Span arrangement	Continuous span with 12+16+12m	
	Superstructure	RC continuous Slab cis	Bridge type
	Substructure	Outer and inner Walls on Raft foundation (Bottom slab)	
	Foundation	Raft foundation	Add cut-off wall at bottom of foundation for scour
	Riverbed	Channelized uniform and constant slope	Required deep excavation of ground at upstream side of the bridge
	River training work	Revetment and guide bank	
Bhyakure	Revetment wall	Compound wall	Protection of Bridge
	Guide bank	Gabion mattress and launching apron	
	Bridge Length	40m	
	Span arrangement	Single span	
	Superstructure	Cast-in-situ 2-webbed Prestressed Concrete Slab-deck	Bridge type
	Substructure	Inverted T-type abutment	No pier
	Foundation	Open foundation	Bearing capacity for open foundation is decided by the geotechnical survey. Require additional embedded depth 2m for scour.
	Riverbed	Channelized uniform and constant slope	Required deep excavation of ground at upstream side of the bridge
River training work	Revetment and guide bank		
Revetment wall	Compound wall	Protection of abutments	
Guide bank	Gabion mattress and launching apron		

Source: JICA Expert Team

## 7 Prepare the Design

### 7.1 Design of Bridges

#### 7.1.1 Basic Considerations

As per the discussion meeting with Department of Roads Officials, following facts are of significant important to consider while designing the bridges in Nepal.

- a) Regarding the Road Classification, Government of Nepal is planning to make classification of Highways (i) Golden Networks and (ii) Standard Networks.
- b) Regarding live loading conditions, shall be consulted relevant IRC: 6-2014 classifications.
- c) Many local contractors are available having capacities of constructing prestressed concrete post tensioning cast-in-situ bridges.
- d) Design of bridges is based on Working Stress Method (Limit State Method is not in use).

#### 7.1.2 Design Standards

Bridge are designed in accordance with the standards below:

- Nepal Bridge Standard 2067(2010), DOR, MOPIT
- Nepal Road Standard 2070(2013), DOR, MOPIT
- Standard Specifications for Road and Bridge Works 2073(2016), DOR, MOPIT

Indian Roads Congress (IRC) and Indian Standard (IS)

- Standard Specifications and Code of Practice for Road Bridges Section I General Features of Design, IRC: 5-1998
- Standard Specifications and Code of Practice for Road Bridges Section II Loads and Stresses, IRC: 6-2017
- Standard Specifications and Code of Practice for Road Bridges Section III Cement Concrete (Plain and Reinforced), IRC: 21-2000
- Standard Specifications and Code of Practice for Road Bridges Section VII Foundation and Substructure, IRC: 78-2014
- Design and Construction of Pile Foundations - Code of Practice Part 1 Concrete Piles, IS: 2911 (Part1/Sec4) 2010
- Guidelines for Design and Construction of River Training and Control Works for Road Bridges IRC: 89-1997
- Guidelines for the Design of Small Bridges and Culverts, IRC: SP13-2004

References

- Hydrological Manual for Infrastructures, H10; Hydrology Manual for Roads and Bridges June 2018, WECS (Water and Energy Commission Secretariat)
- The Study for the design criteria on the transit road over devastated river, 1982, Technical Center for Sediment Control and Landslide, Japan

#### 7.1.3 Bridge Deck Slabs and Girder

Based on the guidelines discussed above, the following criteria are needed to be considered while designing bridges (Deck Slabs)

1. Deck Slab Type: This Bridge Superstructure is designed for One Lane of IRC Class 70R Loading of Wheeled and Tracked (uniform strength load), Two Lanes of IRC Class A Loading, and One Lane of IRC Class A Loading, whichever governs,

In addition to a Footpath Live Load corresponding to 500 kg/m<sup>2</sup> of Footpath area as per Clause 206.3 of IRC-6 (2014). (Live Load Conditions)

2. High strength Ordinary Portland Cement 53 grade, conforming to IS: 12269 or 43 grade conforming to IS: 8112, capable of achieving the required design concrete Strength and Durability, shall be used.
3. Cement content in the concrete mix for Reinforced Concrete shall not be less than 350 kg/m<sup>3</sup> and not more than 450 kg/m<sup>3</sup>.

Cement content for prestressed concrete shall not be less than 400 kg/m<sup>3</sup> and not more than 500 kg/m<sup>3</sup>.

4. All reinforcing steel bars shall be High Yield Strength Deformed HYSD type and Thermo Mechanically Treated, having specified minimum 0.2 per cent (0.2%) proof stress of 500 MPa (Fe 500) conforming to IS: 1786.
5. Minimum Clear Concrete Cover to reinforcement bars shall be 40mm.
6. The structural concrete involved in this Bridge Deck shall be suitably designed as High Strength Concrete Mix having 28 days minimum works cube crushing strength in compression on 150 mm standard cubes as follows:
  - for the cis Prestressed Concrete Post-tensioned superstructure with M 45 (fck=45 MPa i.e. M 45 grade concrete by cube and around 35 MPa by cylinder mold)
  - for the cis and precast Reinforced Concrete in Footpath, Road Kerbs, Parapet Bases and Parapet Posts with M 35 (fck=35 MPa grade concrete by cube)
  - for the entire cast-in-situ (cis) Reinforced Concrete Deck Slab with M 30 (fck=30 MPa grade concrete by cube)
  - for the cast-in-situ cis RC abutment, wingwall, outer and inner wall, bottom slab such as substructure M 30 (fck=30 MPa grade concrete by cube)
  - for the cast-in-situ cis RC approach slab as substructure M 30 (fck=30 MPa grade concrete by cube)

Table 7-1 Characteristics Strength of Concrete

Structure	Grade Designation	Specified Characteristic Compressive Strength of 150mm cubes at 28 days (MPa)	Target Mean Strength (MPa)
PC Post-tensioned Beam	M 45	45	58
Footpath, Kerb, Precast Slab	M 35	35	47
RC Deck Slab, RC Top Slab	M 30	30	42
RC Substructure, Foundation	M 30	30	42
RC Approach Slab	M 30	30	42
RC Plane (Lean concrete)	M 15	15	25

7. For bridge decks which are to receive an asphaltic overlay, residual curing membrane (after curing) shall be removed prior to the overlaying.
8. Live Load: IRC 1 lane of or 1 or 2 lanes of Class A, whichever governs, and Footpath Loading
9. The acceptability criteria of Standard Cube crushing test results shall be that not more than 5% of works cubes fall below the specified minimum works strength. For this to be fulfilled, the Mean Strength of works cubes tested at 28 days age less 1.64 times the "Standard Deviation" should not be less than the required minimum 28 day works cube strength.

10. ALTERNATIVELY (if the Standard Deviation for the concerned Concrete-Mix has not been established), the cube strength shall be accepted as complying with the strength requirement either "if none of the specimens tested falls below the minimum specified strength" or "if the average strength of the specimens is not less than the specified minimum, no individual test result falls below 85% of the minimum required works strength and the difference between the maximum and the minimum strengths of the test specimens is not greater than 20% of that average".
11. Asphaltic concrete wearing course, 75mm thick at roadway crown, gradually reducing to 50mm at the road kerbs, shall be provided over the deck slab.

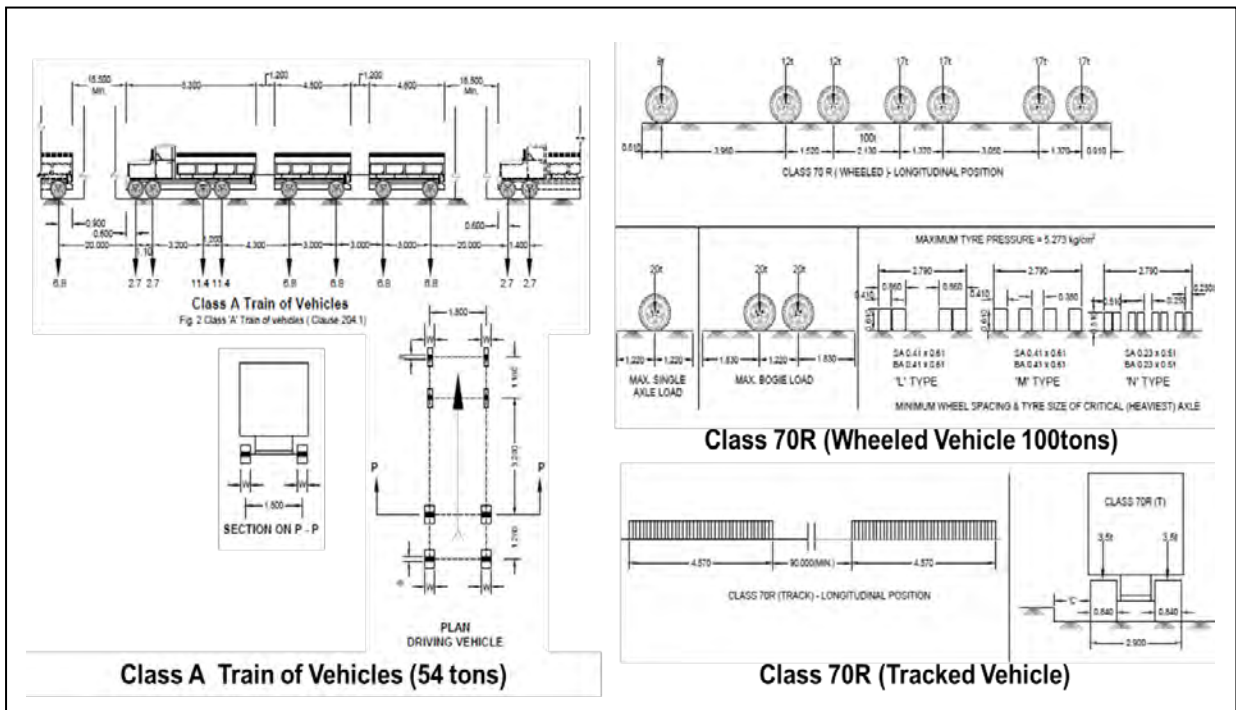

Live Load IRC

12. The Horizontal Seismic coefficient assumed is 0.27 (i.e. 0.27G) accompanied by a Vertical seismic coefficient of + or - 0.135G. Seismic load  $K_h = 0.15$ .
13. The load case combinations considering above design loads, are presented in Table 7-2 below:

Table 7-2 Load Combinations and Permissible Stress

SN	Load Combination	Force direction	Isolated Substructure				RC continuous Slab with Raft Foundation		
			I	I	IIA	VI	I	VI	
1	Dead load Superstructure	Vertical	1	1	1	1	1	1	
	Dead load Self Weight	Vertical	1	1	1	1	1	1	
2	Live Load	Vertical	1	1	1	0.2	1	0.2	
	Vehicle Impact	Vertical	1	1	1	0.2	1	0.2	
	Footpath Load	Vertical	1	1	1	0.2	1	0.2	
3	Braking Effect	Horiz.	1	1	1	0.2	1	0.2	
4	Buoyancy	Vertical		1					
5	Earth Pressure	Horiz.	1	1	1	1	1	1	
6	Temperature	Horiz.			1				
7	Seismic	Horiz.				1		1	
8	Permissible Stress		100%	100%	115%	150%	100%	150%	

Source: IRC: 6-2016 Clause 202.3

7.1.4 Superstructure, Substructure and Foundation

(1) Cast-in-situ 2-webbed Prestressed Concrete Slab-deck bridge for Ghyampe and Bhyakure

[Ghyampe and Bhyakure Bridge]

1) Superstructure and Substructure

At the proposed site of these bridges, Ghyampe and Bhyakure tributaries crossing the existing Sindhuli Road, approximately 40 m wide at downstream of the crossing road, runs over alluvial stream terrain condition. As the water streams of each tributaries have shallow river channel and observed boulders within the flat waterways were mid. sized, the flood flow at these sites are caused deep scour at the downstream side of crossing road constructed by concrete slab of causeway. Therefore, a long and single span of reinforced concrete beam bridge cast-in-situ were adopted as the most reasonable bridge type not installing a pier within the waterway. 40 m of simply supported bridge of Cast-in-situ 2-webbed Prestressed Concrete Slab-deck by typical standard drawing is adopted and the following HWL and scoured depth are required. Substructure will be designed by reinforced concrete inverted T-type abutment.

Description		Ghyampe Bridge	Bhyakure Bridge
Vertical clearance	High flood height with margin	3.5 m	4.1 m
	Free board	1.5 m	1.5 m
	Total height at u/s bed level	5.0 m	5.6 m
Scouring depth	Embedded depth	4.9 m (Maximum scour depth)	4.7 m (Maximum scour depth)
	Additional embedded depth	2m for open foundation	2m for open foundation
	Total depth below foundation at downstream side bed level	6.9 m	6.7 m
Riverbed condition	Channelized bed	7% constant slope	4% constant slope
	Scour floor protection	Gabion mattress at d/s	Gabion mattress at d/s

2) Foundation

RC inverted T-type abutment is adopted as standard and is designed to keep the height 16m. Foundation is designed as open foundation assuming the bearing stratum at sedimented dense gravel confirmed by the rotary boring and N-value test. As the N values obtained in the geotechnical survey were about 16 m, the unconfirmed comp Therefore, the permissible bearing capacity of the both site foundation ground was adopted as 440 kN/m<sup>2</sup> determined based on the shear failure criterion and settlement limiting to 50 mm depth criteria. Inverted T-type abutment with open foundation has been decided by geotechnical survey result with the drilling investigation (see Annex-4)

3) Elevation and Cross section View

Ghyampe Bridge

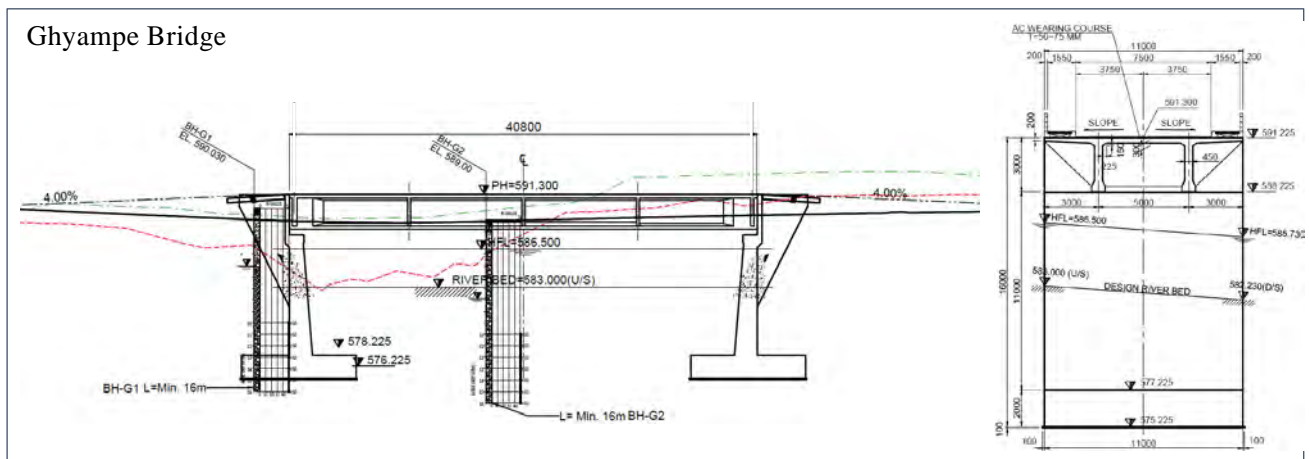

Bhyakure Bridge

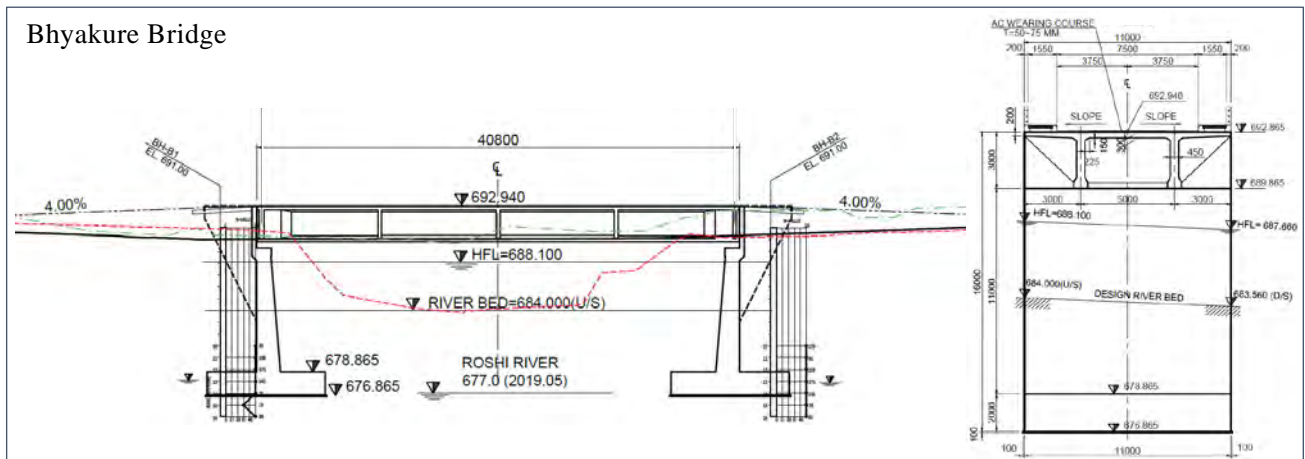

4) Bearings

- “POT” and “POT-PTFE” bearings shall be used. their material specification, design acceptance criteria and installation shall be generally in accordance with IRC: 83 Part 3 (2002).
- The bearings shall be obtained from approved and experienced manufactures.

5) Structural Design of Abutment for Ghyampe and Bhyakure bridge has been presented in *Annex-7*.

(2) RC continuous Slab bridge on raft foundation for Mamti

1) Superstructure and Substructure

At the proposed site of the bridge, Mamti tributary crossing the existing Sindhuli Road, approximately 36m wide at downstream of the crossing road, runs over alluvial stream terrain condition. As the water streams of the tributary has shallow river channel and observed boulders within the flat waterways up to flood flow occurred in the end of May 2014. the flood-flow at these sites are caused deep scour at the downstream side of the crossing road constructed by concrete slab of causeway. Therefore, a long and single span of reinforced concrete beam bridge cast-in-situ were adopted as the most reasonable bridge type not installing a pier within the waterway. 3 spans of RC continuous slab bridge is adopted and the following HFL and scoured depth are required for raft foundation.

Scour protection measures is to provide the raft foundation with cut-off walls at both u/s and d/s parts and provision of flexible gabion mattress apron towards d/s sides of the bridge.

Description		Mamti Bridge
Vertical clearance For debris flow stopping section	High flood height with margin	3.4 m
	Free board	1.5 m
	Total height at u/s bed level	4.9 m
Scouring depth	Embedded depth	4.7 m (Maximum scour depth)
	Cut-off walls at u/s and d/s sides	0.5m depth beneath the foundation
	Total depth below foundation at downstream side bed level	4.7m
Riverbed condition	Channelized bed	6% constant slope
	Scour floor protection	Gabion mattress at d/s
Protection boulder	There are some possibility of rolling mid. size boulder	Jacketing at inner walls and gabion boxes placed at u/s side

## 2) Foundation

Reinforced concrete raft foundation, continuous over the three of spans, is adopted to keep in the total height 12m. Foundation is designed as raft foundation assuming the bearing stratum at sedimented dense gravel confirmed with similar excavated condition of bridges at the Sindhuli Road Construction Project in Section IV and Section III between Dhulikhel and Khurkot. In the raft foundation design, the reaction force to the beam on the elastic foundation is calculated as the spring support based on the SPT N-value of the bearing stratum. This SPT N-value was assumed 30 as a weak bearing layer of dense gravel estimated from actual condition on excavation on the floor-bearing support for the Sindhuli Road Construction Project, without borehole investigation.

## 3) Elevation and Cross Section of the bridge.

Mamti Bridge

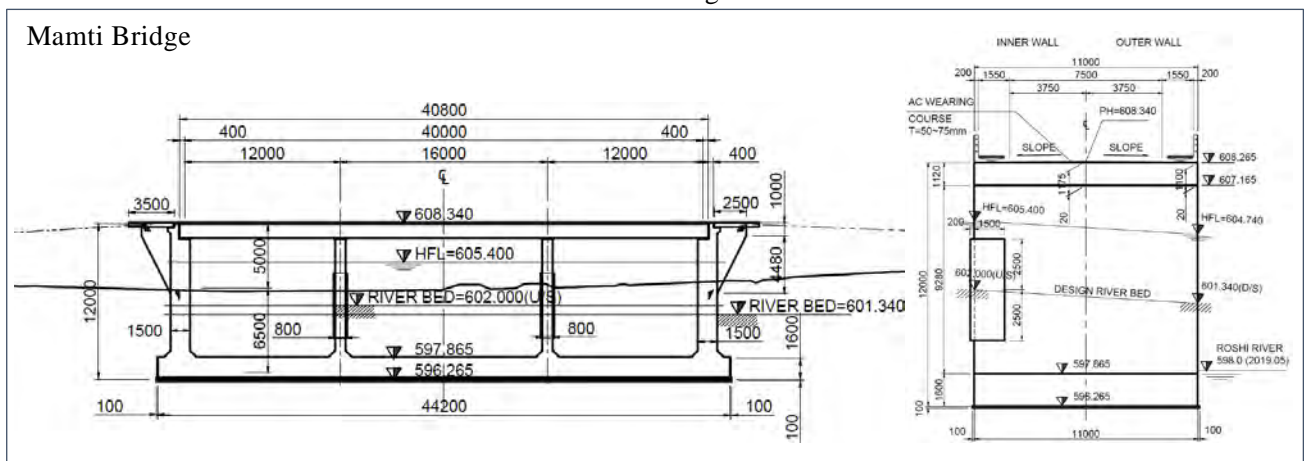

## 4) Bearing

- The tar paper bearing 300 mm wide and 5 layered shall be used.

## 5) Structural Design of RC continuous Slab bridge has been presented in Annex-6.

### 7.1.5 Approach Slab

- 3.5m long, 7.5m wide Approach Slab shall be provided behind each abutment as generally shown in drawings. No: 6/12 of 2-webbed PSC-Slab-Deck cis 40m-SS span. These shall be cast on fully compacted backfill over suitable PCC leveling course.
- Approach Slab shall be 300mm thick and minimum 3.5m length in M 30 grade concrete by cube. The length adopted 3.5m for the bridges.
- Reinforcement at its top and its bottom, each shall be 12mm dia. bars c/c 150mm both ways.
- Suitable arrangement for footpaths shall be provided on each side of Approach Slab taking due account of connections to utilities.
- Asphaltic wearing course shall be laid over the Approach Slabs matching the level & profile of wearing course on the adjacent bridge deck.

### 7.1.6 Construction Plan of the Bridge

- The bridge construction sites are located rainfall affected area where has above 10 rainy days in a month in rainy season between June and September. Hence, excavation works for foundation of the bridges at main stream of the waterway will not be possible and construction of minor structures may only be possible in rainy season. Therefore, the construction schedule has to be planned on the condition that there will not be progress of earthworks in rainy season and the construction management with care due to rain like finishing unstable portions before rainy seasons are essential in order to complete the project successfully.

- Superstructure will be cast in situ on the all staging support.

### 7.1.7 Considerations in Standard Design of PC Post-tensioned 2-webbed Bridge cis on all staging

Department of Roads has provided several Reference Notes in Standard Drawings (Page 1 to Page 12) and some of the points have been re-posted here considering their importance.

- The NOTES given in Drawings No: "1/12 to 5/12 of 2-Webbed PSC- Slab-Deck is 40.0m-SS Span" are applicable for the Superstructure covered by Drawings No. 6/12 to 12/12 of 2-Webbed PSC-Slab-Deck cis 40.0m-SS Span, and must be followed strictly.
- All materials and workmanship shall be in accordance with these NOTES and those in the stated Drawings and shall be generally in accord with the applicable Specifications and relevant Standards/Codes of Practice specified therein and Sound Engineering Practice.
- The Contractor shall be responsible for constructing and maintaining all parts of the structure in stable, acceptable and serviceable condition, ensuring no part under construction is unduly stressed and unsafe.

### CONSTRUCTION SEQUENCE

- Entire Deck (i.e. the superstructure comprising the cast in situ prestressed concrete two webbed slab) shall preferably be concreted in one operation in one day for one span. If this is not possible, then the two webs shall be cast one after the other (each up to about 150 mm below the top throat) on one day (if possible) otherwise on two successive days, one after the other, along with the Cross Girders, and then the slab cast on the next day. The entire Deck must be cast in-situ on staging in span in no more than three successive days.

### CEMENT

- High strength Ordinary Portland Cement 53 Grade, conforming to IS: 12269 or 43 Grade conforming to IS: 8112, capable of achieving the required design concrete Strength and Durability, shall be used
- Cement shall be obtained from approved Manufacturers only
- Cement content in the Concrete Mix
  - for PRESTRESSED CONCRETE: not less than 400 kg/m<sup>3</sup> AND not more than 500 kg/m<sup>3</sup>
  - for REINFORCED CONCRETE: not less than 350 kg/m<sup>3</sup> AND not more than 450 kg/m<sup>3</sup>

### ADDITIVES

- To suitably improve workability and increase initial setting time of concrete and cement grout, admixtures conforming to IS: 9103, and ASTM C-494 Type F water-reducing, high range admixtures, shall be permitted in appropriate dosages, subject to their satisfactory proven use.

### REINFORCEMENT

- All reinforcing steel bars shall be High Yield Strength Deformed type and Thermo Mechanically Treated, having specified minimum 0.2 per cent proof stress of 500 MPa conforming to IS: 1786.
- Minimum lap-length of reinforcement bars shall be 65d where d is the dia. of the smaller diameter bar to be lapped (unless otherwise specified).
- Not more than 50 percent of reinforcement crossing a section shall be lapped at that location.
- All laps in reinforcement shall be properly staggered and minimum distance between the laps shall be 1.33 times the lap length.
- Bending of reinforcement bars shall be as per IS 2502.

### CONCRETE AND CONCRETING

- WATER-CEMENT RATIO, by weight, shall not exceed 0.40 for Reinforced Concrete, and 0.37 for Prestressed Concrete.
- MINIMUM CLEAR CONCRETE COVER to reinforcement bars shall be 40mm.
- CONTROL OF SURFACE EVAPORATION
- Use the graphical Figure below to estimate and control the loss of water through surface evaporation in the laid concrete:

### GRADES OF CONCRETE

- The structural concretes involved in this bridge deck shall be suitably designed as high strength concrete mixes having 28

days minimum works cube crushing strength in compression on 150 mm standard cubes as follows:

for Reinforced Concrete in- Precast Footpath Slabs, Parapet Posts and their Bases, Road Kerbs	35 MPa (i.e. M-35 grade concrete)
for the cast in situ (cis) Prestressed Concrete, 2- webbed slab, superstructure (i.e. for it, stems/girders, slab and cross-girders)	45 MPa (i.e. M-45 grade concrete)

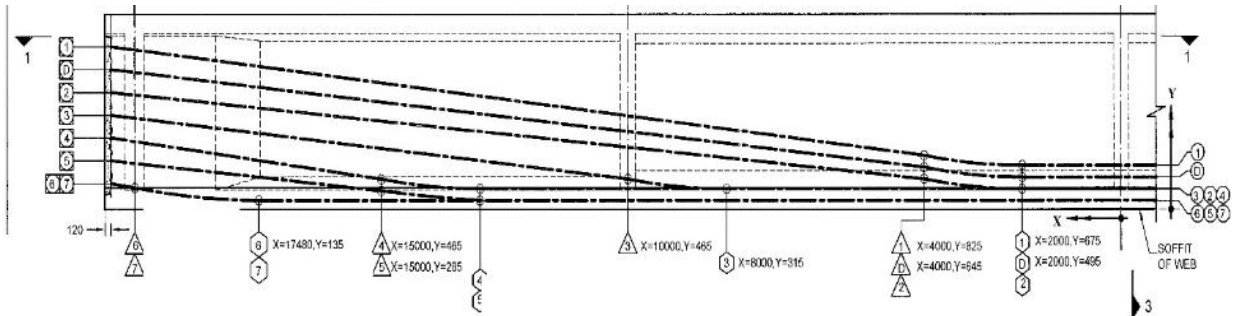

TABLE: 1

Horizontal Distance "X" from Mid span section	AT X=20480		AT X=20000		AT X=18000		AT X=16000		AT X=14000		AT X=12000		AT X=10000		AT X=8000		AT X=6000		AT X=4000		AT X=2000		AT X=0			
	y	z	y	z	y	z	y	z	y	z	y	z	y	z	y	z	y	z	y	z	y	z	y	z		
CD	2500	0	2451	0	2248	0	2045	0	1841	0	1638	0	1435	0	1232	0	1028	0	825	0	675	0	675	0		
@	2150	0	2106	0	1924	0	1741	0	1558	0	1376	0	1193	0	1010	0	828	0	645	0	495	0	495	0		
⊙	1800	0	1761	0	1599	0	1437	0	1275	0	1113	0	951	0	789	0	627	0	465	0	315	0	315	0		
⊙	1450	0	1405	0	1217	0	1029	0	841	0	653	0	465	0	315	0	315	139	315	180	315	180	315	180	315	180
	1100	0	1044	0	813	0	581	0	370	0	315	40	315	180	315	180	315	180	315	180	315	180	315	180	315	180
(5)	750	0	709	0	540	0	370	0	205	0	135	0	135	0	135	0	135	0	135	0	135	0	135	0	135	0
(6)	400	162.5	335	162.5	153	162.5	135	171	135	180	135	180	135	180	135	180	135	180	135	180	135	180	135	180	135	180
⊙	400	162.5	335	162.5	153	162.5	135	171	135	180	135	180	135	180	135	180	135	180	135	180	135	180	135	180	135	180

- NOTES: 'X'= HORIZONTAL DISTANCE FROM MID SPAN SECTION
- 'Y' =VERTICAL DISTANCE TO CENTERLINE OF CABLE ABOVE SOFFIT OF WEB
- 'Z' =HORIZONTAL DISTANCE TO CENTERLINE OF CABLE FROM CENTERLINE OF WEB

**NOTES:**

All dimensions are in millimeters, unless stated otherwise.

1. No dimension shall be scaled from the Drawings; only written dimensions shall be followed.
2. This drawing shall be read in conjunction with all relevant NOTES given in Drawings No:1/12 to 5/12 of 2-Webbed PSC-Slab-Deck cis 40.0 m-SS span- especially those dealing with Prestressing.

NOTE: Cables marked 'D' are the Dummy Cables.

3. This drawing shall also be read in conjunction with Drawing. No: 6/ 12 & 8/ 12 of 2-Webbed PSC-Slab-Deck cis 40.0 m-SS span.

4. The sequence of stressing of multistrand cables shall be as follows:

(i) PS-I Cables (i.e. cables of 1st stage of Prestressing)

Stress Cable No: 1 in one web;

- Then stress Cable No: 1, followed by Cable No: 2, in the second web ;
- Then stress Cable No: 2, followed by Cable No: 3, in the first web;
- Then stress Cable No: 3, followed by Cable No: 4, in the second web;
- Then stress Cable No: 4, followed by Cable No: 5, in the first web;
- Then stress Cable No: 5 in the second web.

(ii) PS-II cables (i.e. cables of 2nd stage of Prestressing)

Stress Cable No: 6 in the first web;

- Then stress Cable No: 6, followed by Cable no: 7, in the second web;
- Then stress Cable No: 7 in the first web.

5. During Stressing of PS-I Cables:

After successfully stressing Cables No: 1 to 4 in each of the two webs, and just before stressing the remaining cables of these PS-I Cables: Lightly Hammer and Loosen the wooden wedge packings from under the soffits of the two webs of

the deck simultaneously -BUT ONLY JUST - to ensure that the deck has now hogged upwards clear of its supporting staging between its ends. (This will confirm that the Prestress applied so far has fully countered and taken up the self-weight of the Superstructure which, therefore, is resting only at its ends and not on the staging any longer and hence the accompanying Decompression of staging columns is complete)

6. CAUTION: The shown Profiles of Prestressing Cables shall be Strictly followed without any compromise, whatsoever. Where absolutely necessary, the Un-tensioned Reinforcement Bars/Meshes may be suitably slightly repositioned to suit.
7. Vertical Ordinates 'Y' and Horizontal Distances 'Z' of Cable-Profiles given in this Drg., are to Center-lines of the Cables from soffit of Web and from Vertical Centerline of Web, respectively. Account should be taken of the of the Cable-duct in welding the 12 mm dia. Cross-bars to the Stirrup-legs for profiling the Cables

## PRESTRESS

- (i) The Prestressing System assumed here can be SAI Prestressing System OR DYNAMIC Prestressing System AND each cable is either: 19JK13 OR 19DP13 type multistrand. An "alternative" equivalent and approved Prestressing system may be used instead so long as the effective Prestressing Force at each section, its eccentricity w.r.t. centroid of each section, and its Moments, Shears, etc. at each section of the Deck are retained unchanged, and the Detailed Design, Detailing and Drawings are duly submitted for checking and approval of the Department of Roads.
- (ii) Each Prestressing Cable shall be a multistrand cable comprising 19 Strands, each strand of 12.7 mm diameter, 7- ply low relaxation Class II High Tensile Steel Conforming to IS 14268-1995.
- (iii) Forming a 19 multistranded cable at site:
  - a. The monostrand is supplied (in large coils) in very long lengths.
  - b. Cut 19 lengths out of the long mono-strand, each length being equal to actual length of the concerned cable required between its stressing Jacks plus additional lengths beyond the Jacks to enable gripping the strands adequately by the Wedges of the Jacks.
  - c. Bunch together these 19 mono-strands into a 'multistrand' holding them together by binding wire tightened around the bunch at about 1.0 m intervals
  - d. Insert these cables in to their respective 90 mm ID Corrugated HOPE Ducts which are already placed to the required profile in the already concreted deck.
- (iv) Provisions for one 19JK13/19DP13 DUMMY CABLE, i.e. its Anchorages, HOPE Sheathing, and Profile details, have been provided in EACH of the two webs (longitudinal girders) of the 2-webbed slab superstructure. Cable Profile details are shown in the attached relevant Prestressing these Dummy Cables may be required in the event of any exigency at site and/or emergency in future. These two Dummy Cables shall be installed only when needed and shall then be stressed only to the extent required but both must be stressed equally one immediately after the other in order to cause only least Temporary eccentric prestress on the Deck, and then Grouted.
- (v)
  - a) Cross-sectional area of HTS. in ONE No: 12.7 mm dia. Strand =  $98.7 \text{ mm}^2$
  - b) Cross sectional area of H.T.S. in 19 strands=  $19 \times 98.7 = 1875.3 \text{ mm}^2$
  - c) Breaking load i.e. Ultimate Tensile Force Per Strand = 183710 N (ref. Table: 3 of IS:6006 (1983)) i.e. 18726.81 Kg i.e. 18.72681 Tonne i.e. 18.72681 T.
  - d) Breaking load i.e. Ultimate Tensile Force of 19 strands of one Multistrand =  $19 \times 18.72681 = 355.81 \text{ T}$
  - e) 0.1% Proof Load per Strand= 0.85 of Breaking Load per strand = 0.85 of 18.72681 T = 15.9178 T i.e. 15918 Kg i.e. 156155.6 N
  - f) 0.1% Proof Load of 19 Stranded Multistrand here =  $19 \times 156.156 \text{ kN} = 2966.964 \text{ kN}$  i.e. 302.443 T
  - g.1 Jacking Force at each end of this Multi-stand as per Clause 8 of IRC-18 (2000) shall not exceed 90% of 0.1% Proof Load: i.e.  $0.9 \times 302.443 = 272.1987 \text{ T}$  Which is 0.765 of Breaking Load of 19 Strands
  - g.2 Hence Jacking Force normally should not exceed 76.5% of the Breaking Load.
  - g.3 However, here we are using a Jacking Force of only 75% of the Breaking Load in the Design, which is  $0.75 \times 355.81 \text{ T} = 266.86 \text{ T}$  for a 19-Stranded Multistrand (19JK13, SAI system OR 19DP13 DYNAMIC System, see Note ahead).
  - g.4 In the very limit (if site exigency so requires) this Jacking Force in a 19JK13/19DP13 multi-strand may be increased to a maximum of 270 T but NEVER MORE.
- (vi)
  - a) The Prestressing Steel and Accessories shall be subject to Acceptance Tests prior to their actual use on the works. (Guidance may be taken from BS 4447). The Prestressing Jacks used shall be only those appropriate for tensioning simultaneously all the 19 strands of a multi-stranded Cable.
  - b) Appropriate "Prestressing Force Measurement Device shall be part of the Multistrand Jack and shall be duly checked and calibrated for correctness and removal of zero-error, regularly, in. consultation with the concerned Manufacturer.
- (vii) All Prestressing Cables shall be laid to smooth profiles using the specified profile ordinates given in the

attached Prestressing Drawing. Short 12 mm dia. cross-bars shall be spot welded to the stirrup legs at approximately 2 m centers along the length of cables to give the necessary profile to the cables.

- (viii) At the time of installation of Cable-Sheathing (HOPE Ducts), the sheathing materials shall be examined for any possible punctures/cuts/etc. and the same shall be sealed with waterproof tape. The number of joints should be kept to the minimum, and each joint adequately sealed against the possibility of any ingress of any material and mortar. Joints in adjacent ducts should be staggered by at least 300 mm. Adequate concrete shield should exist between the adjacent ducts to prevent any accidental flow of grout from one duct to the other and the ducts shall be strictly maintained in their correct alignment and profile during the placing of concrete
- (ix) Before commencement of prestressing, it should be ensured that all the Cables/Ducts are free of any clogs and that the structure-members are free to accommodate the horizontal and vertical movements due to application of prestress, and that there is enough space for the movement of the jack piston.
- (x) Each Cable shall be stressed from both its ends simultaneously, equally and gradually, and the extensions recorded at each suitable increment of Jacking Force.
- (xi) For tensioning a cable, the initial slack in it shall first be removed (taken-up) by applying a relatively small initial tension from each end as required to remove the slack. The initial tension required to remove this slack shall be taken as the starting point for measuring the cable elongations and the correction shall be applied as per clause 12.2.1:3 of IS: 1343 (1980).
- (xii) The Cable > Elongations at their Jacking-Points, mentioned in the attached relevant Prestressing Drawing, are based on the assumption that the Modulus of Elasticity of Cable-steel,  $E_s = 1.95$  (10s. MPa (i.e.  $1.988 \times 10^6$  kg/cm<sup>2</sup>). However, if  $E_s$  of the actually supplied Cable-steel at site is slightly different, then the required Elongations at each end shall be re-worked out at site by multiplying the specified values by the ratio of (assumed  $E_s$  / actual  $E_s$ ), and these shall then be the 'correct' specified extensions.
- (xiii) Sheathing (Ducting for housing the 19-multi-stranded Cables) The sheathing for prestressing cables shall be corrugated "HOPE type", 90 mm ID (wall thickness  $2.3 \pm 0.3$  mm as manufactured and 1.5 mm after loss of compression) and shall be tested as per IRC:18 (2000), Appendix 1.
- (xiv) For the above multi-strands in HOPE sheathing, Wobble Friction Coefficient:  $K = 0.002$  per meter, and Curvature Friction Coefficient:  $f_1 = 0.17$  per radian, have been assumed in Design.
- (xv) Cable-Elongation at each end of each cable, given in the attached Prestressing Drawing, has already taken into account. The actual cable-length along its profile between the gripping points of the Tensioning Jacks placed nearest the Anchorages.
- (xvi) The effect of a 10 mm cable slip (anticipated at each Jacking-end) also has already been taken into account in evaluating the effective prestressing Force at each section along the Cable after and friction losses due to Curvature and Wobble.
- (xvii) a) Prior to concreting the Deck, INSERT 80 mm ID Plain HOPE Ducts into the 90 mm ID Corrugated HOPE Ducts (Which have already been placed to the required cable profiles), protruding them suitably beyond the cable-Anchorage.  
 b) After concreting of the Deck is over. REMOVE these 80 mm ID Plain HOPE Ducts AND quickly blow oil-free compressed air through the emptied 90 mm ID Corrugated HOPE Ducts in order to flush them clean. Stand-by flushing equipment, capable of developing a pumping pressure of 20 g/cm<sup>2</sup> (2 MPa) and a sufficient capacity to flush out any blockages due to any accidental partial grout leaks in ducts, shall be kept available at site.  
 c) The 19-stranded multi-strands may now be inserted in to their <respective 90 mm 10 corrugated HOPE Ducts already placed inside the Concreted Deck.
- (xviii) TENSIONING OF PRESTRESSING CABLES:
  - a) Normally, the specified required extensions shall be achieved at the specified Jacking Forces at stressing ends.
  - b) In case these required extensions are somehow not achieved at these specified Jacking Forces, the stressing (tensioning) shall be continued (where possible) till the required extensions are obtained but subject to the Jacking Force at Cable-ends NEVER exceeding 270T.
  - c) Should the required extensions be obtained at Jack Forces lower than the specified Jack Forces, then the stressing should be continued till the specified Jack Forces are reached but provided the "sum of the 'additional' extensions" so achieved is not more than 5% of the "sum of the 'specified' extensions".
  - d) Cables satisfying these provisions shall be locked (i.e. anchored).
  - e) However, if the Jack Forces are still lower than their specified values despite the 5% increase in the "sum of the 'specified' extensions", then the particulars of such cables shall be reported to the Designer for further instructions ('locking' but not 'grouting' these cables yet until receipt of instructions, just in case).
  - f) If for any cable, the required extension at any one end is not achieved despite the Jack Force in the cable at that end reaching 270 T (the maximum allowable Jacking Force), then the "total balance extension" should be attempted for at the other end BUT the Jacking Force SHALL NEVER EXCEED 270.
  - g) Also, for any cable, the extension at any one end shall not exceed the "sum total extension required for the cable at that end" by more than 5%.

- h) Extensions should also be checked 24 hours after anchoring the cables to guard against the possibility of 'slow slipping', if any. If the average observed 'slow slip' at anchorages of a cable exceeds 3mm, the matter should be reported to the Designer for any further instructions.
- i) All cables which satisfy the above provisions shall be grouted, taking care that the cables not yet stressed do not get accidentally blocked due any internal grout leak.
- (xix) Prestressing tendons shall never be heated or exposed to flame or to welding. Protruding Ends of tensioned strands of Grouted Cables, protruding beyond anchorages, shall only be saw-cut, not flame-cut. Recesses at anchorages (in the Girder- ends) shall be filled and sealed with non-shrink cement mortar after the protruding strand-ends of tensioned, anchored and grouted cables are cut to suit.
- (xx) Prestressing cables shall be protected against any unacceptable rusting, damage due to 'pitting', and any greasing. The strands must be thoroughly cleaned with petrol at locations where Stressing Jacks and Wedges have to grip them.
- (xxi) **SEQUENCE OF STRESSING AND STAGES OF PRESTRESSING:**
  - a) The Sequence of Stressing of Cables shall be as indicated in the attached relevant Prestressing Drawing and the prestressing shall be accomplished in TWO STAGES: PS-I and PS-II as stated therein.
  - b) First Stage Cables i.e. PS-I cables shall be stressed in their indicated sequence when the last cubic meter of concrete in the deck-slab (laid last in concreting the "two-webbed slab" Deck) has attained a work's cube crushing compressive strength of at least 400 kg/cm<sup>2</sup> and is more than 10 days old (after the day of its casting).
  - c) Cables of PS-II shall be stressed in their indicated sequence when concrete in the deck slab has attained a work's cube crushing compressive strength of at least 450 kg/cm<sup>2</sup> and is at least 28 days old (after the day of its casting).
  - d) The Sequence of stressing the cables in Stage-I Prestressing (i.e. in PS-I) and Stage-II Prestressing (i.e. in PS-II) is shown in the attached relevant Prestressing Drawing.
  - e) After successfully stressing the PS-I Cables the deck becomes self-supporting between its ends. The Contractor may now carefully release the Staging supporting the Deck.
  - f) The Dirt-walls of the two Abutments shall be constructed after successfully Prestressing and Grouting the cables of the Decks supported by the Abutments.
- (xxii) After completion of stressing and anchoring a cable, the Jack Force shall be released in such a way so as to avoid shock to the anchorage and the cable.
- (xxiii) Complete record of all Prestressing and Grouting shall be carefully maintained at site.
- (xxiv) An appropriately experienced Technical representative of the Supplier of Prestressing system shall carry out and supervise all Prestressing and Grouting Operations at site and ensure, monitor and certify their correctness.

#### **GROUTING THE DUCTS OF SUCCESSFULLY: TENSIONED CABLES:**

- (i) Prestressing steel shall be bonded by the Grout to the concrete by filling the void space between the duct and the tendon with cement grout.
- (ii) For this purpose, each cable shall normally be Grouted within 5 days of completion of its successful tensioning unless specific requirements require delaying it till certain other cables are first successfully stressed. HOWEVER, in the present case, all the PS-I and PS-II cables may be grouted (one after the other) immediately after the last of these cables has been successfully stressed (when the concrete in the Deck is about 30 to 35 days old).
- (iii) The Grout shall consist of Ordinary Portland Cement, Water, and an Expansive Admixture approved by the Engineer. All grout shall pass through a screen with 2 mm maximum clear openings prior to being introduced into the grout-pump. No admixtures containing chlorides and nitrates shall be used.  
  
Water shall be of potable quality and free of any salts and sugars (as per Specifications) and shall be added to the mixer first, followed by cement and the admixture.
- (iv) The Grout shall be mixed in mechanical mixing equipment of a type that will produce uniform and thoroughly mixed colloidal grout. The water content shall not be more than 24 liters per 50 kg sack of cement. Retampering of grout shall not be permitted. Grout shall be continuously kept agitated until it is pumped in.
- (v) Grouting Equipment shall be furnished with a pressure gauge having a full-scale reading of up to 20 Kg/cm<sup>2</sup> (2 MPa) and it shall be capable of grouting at a pressure of at least 10 Kg/cm<sup>2</sup> (1 MPa).
- (vi) Prior to placing the shuttering, the Contractor should demonstrate to the satisfaction of the Engineer that all ducts are unobstructed and, if the prestressing reinforcement has been placed, that the Cable-steel is free and not bonded in the duct.
- (vii) If the expansive Admixture (generally an Aluminum compound) is used to expand the Grout, it shall be added strictly as per Manufacturer's instructions. The ducts shall be completely filled from the low end, with grout, under NOT MORE THAN 7 kg/cm<sup>2</sup> pressure. Grout shall be pumped through the duct and continuously wasted at the outlet until no visible slugs of water or air are seen. All vents shall then be closed and the grouting pressure at the injection-end raised to 10 kg/cm<sup>2</sup> and held for a minimum of 10 seconds before closing the

hole in the cable-anchorage at the injection-end.

- (viii) If some delays in Grouting are unavoidable (e.g. due to sequence of construction planned), temporary protection against corrosion shall be provided by ventilating the Ducts with dry/hot air, since any humid conditions contribute considerably to acceleration of corrosion of cable-steel.

#### **BEARINGS**

- (i) "POT" and "POT-PTFE" BEARINGS shall be used. Their Material specifications, Design, Acceptance Criteria and Installation shall be generally in accordance with IRC: 83 part 3 (2002), the AASHTO Design Specifications, and Sound Engineering Practice
- (ii) The Bearings shall be obtained from approved and
- (iii) experienced Manufacturers.
- (iv) Installation of Bearings shall be carried out under the expert supervision of the Manufacture's Technical Representative.
- (v) The Design of Bearings shall be based on the Design Loads, Rotations, etc., given in the appropriate Table in the attached relevant Drawing.
- (vi) Detailed Shop Drawings shall be prepared by the Manufacturer, which shall be checked and duly approved before the Bearings are manufactured and installed.
- (vii) The Grout Bedding Mortar, where used, shall be high strength free flowing Non-Shrink Grout.
- (viii) All Bearings shall be placed in truly horizontal plane only and to true line and direction (unless shown differently), as generally indicated in the attached relevant Drawing.
- (ix) IMPORTANT NOTE
- a) The Superstructure in a span can be lifted upwards at each of its ends (work only at one end at a time) by operating the appropriate - capacity LIFTING JACKS applied under the end-cross girder at that end as indicated in the attached relevant Drawing.
- b) Each of these Lifting Jacks shall have a Safe Lifting Capacity of 200 tones.
- c) All Hydraulic Lifting Jack shall be connected to a common oil-bath manifold so that- in the event of any emergency while lifting, e.g., Washer-burst, etc., in a Jack the oil. being pumped shall automatically recirculate and cause to lower all the Jacks simultaneously and equally, in unison.
- d) All Jacks must be operated simultaneously, equally, and in unison.
- (x) Pier Caps and Abutment Caps MUST also be structurally adequately designed for the Reactions from the said Lifting Jacks.
- (xi) A conditions-free warranty of at least 10 years after opening of the Bridge to the traffic shall be furnished by the Contractor and the Manufacturer/Supplier of the Bearings.
- (xii) ALL Bearings shall be placed in their final and correct positions (as per details shown in the attached relevant Drawing) over the R.C. Pedestals before casting the Deck (i.e. superstructure) in-situ.

#### **EXPANSION-CONTRACTION JOINTS**

- (i) These Movement Joints shall be provided in the deck as Specified and shown in attached relevant Drawing. These shall be of Approved Quality and shall be fitted under the expert supervision of the Manufacturer at the appropriate ambient Temperature as per Design.
- (ii) A conditions-free warranty of at least 10 years after opening of the Bridge to the traffic shall be furnished by the Contractor and the Manufacturer/Supplier of these Expansion-Contraction Joints.

#### **WEARING COURSE**

Asphaltic concrete wearing course, 75mm thick at roadway crown, gradually reducing to 50mm at the road kerbs, shall be provided over the Deck Slab.

#### **EARTHQUAKE EFFECTS**

The Horizontal Seismic coefficient assumed is 0.27 (i.e.0.27G) accompanied by a Vertical Seismic coefficient of+ or- 0.135G.

### 7.1.8 Geometrical Shape of River Training Structure

The results of the analysis of river training works and design calculation for the compound walls are presented in *Annex-8 Design for River Training Work*.

The minimum required length of upstream part of the river training should be 25 per cent more than the length of structure between the abutments (L). The length of downstream part of the guide bank should be 1/4 of the bridge length for flood discharges up to 20,000 cumecs, recommended by Gales, "Irrigation Engineering and Hydraulic Structures, Santosh Kumar Garg, August 2009" and IRC: 89-1997.

The length of the guide bund upstream from center of the bridge =  $1.25 \times L$  (40) = 50 m

The length of the guide bund downstream from center of the bridge =  $0.25 \times L$  (40) = 10 m

The radius of the curved head at upstream portion if not continue cutting earth bank =  $0.45 \times L$  (40) = 18 m

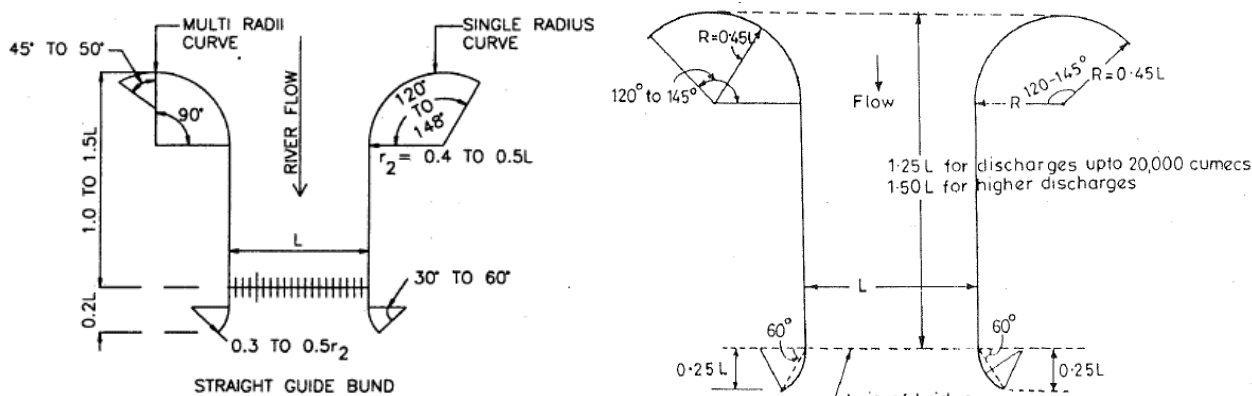

Fig. 8.16. Gale's recommendations for guide banks.

Source: IRC 89-1997\_Guidelines for Design and Construction of River Training and Control Works for Road Bridges  
 Source: Irrigation Engineering Hydraulic Structure, by S.K. Garg recommended, August 2009 by DWRI

Two guide banks for the three tributary sites are necessary due to waterway openings are in the middle of a flood plain. The minimum width between guide banks are the width necessary to provide the required waterway opening through the bridges.

### 7.1.9 Design Return Period of River Training Structure and Drainage Facilities

Return period of rainfall for the design of drainage facilities and river crossing structures will be set as shown in Table 7-3 below.

Table 7-3 Return Period for River Training and Drainage Facilities

Facility	Application Condition	Return period (Year)
Side ditch	for road surface and small-scale slopes	3
Cross drain (Culvert) A	for large natural slopes	5
Cross drain (Culvert) B	for important large natural slopes	10
Channel works A	for important drainage in terms of road management	25
Channel works B Retaining Wall	for important drainage and retaining wall on the large-scale embankment	50
Bridge		100

Design discharges of river training structure should be for the return periods of 50 years.

### 7.1.10 Determination of Vertical Clearance of the River Training

The Clearance height of the river training structure basically can be defined the linear waterway at HFL. River training structure height/ Natural bank height > Design flood level (HFL, 50 years return period) + Freeboard

*H<sub>VC2</sub> Against Stopping of Debris-flow (Bed Slope S=17~5%)*

Where,

*H<sub>SD</sub>* = Sediment deposit depth (m) = Maximum size of Boulder*H<sub>FF</sub>* = Height of Peak Flood-flow (m) at *Q<sub>P</sub>**H<sub>DC</sub>* = Clearance for Gravel/Mud type Debris-flow (m) = Maximum size of Boulder*H<sub>FB</sub>* = Free board for Bridge based on *Q<sub>P</sub>* (m) by Bridge Standard*H<sub>VC2</sub>* = Vertical Clearance = *H<sub>SD</sub>* + *H<sub>FF</sub>* + *H<sub>DC</sub>* + *H<sub>FB</sub>* (m)

Table 7-4 Calculation of Vertical Clearance for River Training

Tributary	50-year Return Period Flood-flow	River Training Opening Width	Design Riverbed Slope	Velocity of flow at <i>Q<sub>P</sub></i>	Sediment Deposit Depth	Flood-flow Height	Clearance of Debris-flow	Free Board at <i>Q<sub>P</sub></i>	Clearance Height
	<i>Q<sub>P</sub></i> m <sup>3</sup> /s	<i>W</i> m	<i>S</i> %	<i>V</i> m/s	<i>H<sub>SD</sub></i> m	<i>H<sub>FF</sub></i> (y) m	<i>H<sub>DC</sub></i> m	<i>H<sub>FB</sub></i> m	<i>H<sub>VC</sub></i> = <i>H<sub>SD</sub></i> + <i>H<sub>FF</sub></i> + <i>H<sub>DC</sub></i> + <i>H<sub>FB</sub></i> m
Ghyampe	371	40	7	7.9	-	1.5	-	1.2	2.5
Mamti	326	38	6	7.1	-	1.2	-	1.2	2.4
Bhyakure	391	40	4	6.6	-	1.6	-	1.2	2.8

Source: JICA Study Team

## 7.1.11 Determination of Scouring Depth for River Training

The design discharge to adopt at 50 years return period for the river training structure.

*Mean Scour Depth*

$$R_s = 1.34 (q^2/f)^{1/3} \text{ for Lacey's Regime Condition}$$

Where,

*Q<sub>P</sub>* = Design Discharge at 50 years Return Period (m<sup>3</sup>/s)*R<sub>s</sub>* = Mean scour depth by Lacey's Regime Condition*q* = Discharge intensity = (Design Discharge *Q<sub>P</sub>*/ width of River *L*) (m<sup>3</sup>/s/m)*f* = Silt factor = 1.76√*m**m* = Size of bed materials in mm, 50% materials are smaller (mm)

For Constriction of Regime Condition

*Normal Scour Depth*

$$D_N = R_s(W/L)^{0.61}$$

Where,

*D<sub>N</sub>* = Normal Scour Depth below HFL (m)*W* = Lacey's Regime Waterway Width  $B = 4.75\sqrt{Q_{F1.3}}$ *L* = Contracted Width = Bridge Length*m* = Size of bed materials in mm, 50% materials are smaller (mm)Max. Depth of Scour = 1.27 x *D<sub>N</sub>*

For the design of floor protection works for raft or open foundations, Clause 703.3.2 of IRC:78-2014

Based on these Condition, the Maximum Scour Depth for River Training at Ghyampe, Mamti and Bhyakure rivers have been calculated and presented in Table 7-5 below.

Table 7-5 Scour Depth Calculation for River Training by IRC: 78-2014

Tributary	General Parameters			<i>B=W</i> m	<i>L</i> m	<i>m</i> <i>D</i> <sub>50</sub> mm	<i>f</i>	<i>R<sub>s</sub></i>	<i>D<sub>N</sub></i> = <i>R<sub>s</sub></i> ( <i>W/L</i> ) <sup>0.61</sup> m	D+y: Scour Depth + Water Depth 1.27 x <i>D<sub>N</sub></i> m	Scoured Depth <i>S<sub>D</sub></i> m
	<i>Q<sub>P</sub></i> 50-yrs m <sup>3</sup> /s	<i>y</i> m	<i>V</i> m/s								
	Ghyampe	371	1.27								
Mamti	326	1.23	7.1	85.8	38	150	21.6	2.02	3.3	4.2	3.0
Bhyakure	392	1.55	6.6	94.0	40	150	21.6	2.20	3.7	4.7	3.2

Source: JICA Expert Team

## 7.1.12 Consideration of Retaining Wall and Guide Bank Structures for River Training

In cases where revetment and foot protection are necessary to be installed, suitable type should be selected in accordance with Table 7-6 and 7-7.

Table 7-6 Selection Criteria for Retaining Wall and Guide Bank in River Training

Type	Height	Grade	Geology	Applied to	Floor protection	Design Conditions
Compound Wall (Wet-stone Masonry + Gravity Wall)	less than or equal to 12.5m (Embankment)	1:0.5	Sand/Gravel or more stable Site: Dense gravel	Retaining Wall for Open foundation At uniform open channel	Launching Apron for safety of scouring	<ul style="list-style-type: none"> <li>Retaining wall shall be secured vertical clearance height.</li> <li>Foundation shall be embedded at calculated scour depth for river training and not less than final assumed bed slope of the (degrading) river.</li> <li>Provision of launching apron and its length shall be decided by calculation.</li> <li>Gravity foundation is adopted for the wall higher than 5m.</li> </ul> <p>→ Adopted to Ghyampe and Bhyakure</p>
Compound Wall (Wet-stone Masonry + Gravity Wall)	less than or equal to 12.5m (Embankment)	1:0.5	Sand/Gravel or more stable Site: Dense gravel	Retaining Wall for Raft foundation At uniform open channel	Launching Apron for raft foundation	<ul style="list-style-type: none"> <li>Retaining wall shall be secured vertical clearance height.</li> <li>Foundation shall be embedded at calculated scour depth for river training and not less than final assumed bed slope of the (degrading) river.</li> <li>Bed bar with launching apron shall be designed for raft foundation.</li> <li>Gravity foundation is adopted for the wall higher than 5m.</li> </ul> <p>→ Adopted to Mamti</p>
Gabion Mattress Slope and Launching Apron	less than or equal to 5m (Embankment)	1:1.5 or milder	Sand/Gravel or more stable	Guide bank	Gabion Mattress Slope and Launching Apron by gabion	<ul style="list-style-type: none"> <li>Top of guide bank shall be secured vertical clearance.</li> <li>Gabion mattress thickness is decided by calculation (0.3~1.0 m).</li> <li>Launching apron shall be the secured.</li> <li>Length of flexible launching apron shall be covered scour depth with margin.</li> </ul> <p>→ Adopted to all of the sites</p>
Gabion Mattress Slope and Boulder Apron	less than or equal to 5m (Embankment)	1:1.5 or milder	Sand/Gravel or more stable	Guide bank	Gabion Mattress Slope and Boulders Apron	<ul style="list-style-type: none"> <li>In case scour depth shall be secured.</li> <li>Boulder material dia. 1 m around and must be available at the river concerned area.</li> <li>Length of boulders apron shall be covered scour depth with margin. Boulders are remained at the Ghyampe site.</li> </ul> <p>→ Adopted to mainly Ghyampe and Mamti</p>
Wet Stone Pitching	less than or equal to 10m (Embankment)	1:1 or milder	Sand/Gravel or more stable	Guide bank	Apron with Cement Concrete Blocks	<ul style="list-style-type: none"> <li>Boulder material dia. 1 m around are available at u/s area.</li> </ul>
Gabion Wall (t=1.0m or 0.5m)	less than or equal to 5m (Embankment) less than or equal to 7m (Cutting)	1:0.1 1:0.3 1:0.5	Sandy soil or more stable	Guide bank	Launching Apron with Gabion mattress	<ul style="list-style-type: none"> <li>Embankment and/or collapsed section and/or landslide block with much seepage water.</li> <li>Concrete materials need not be procured, and thus all works have to be done by labor manpower.</li> </ul>
Wet Stone Masonry Wall	less than or equal to 5m (Embankment) less than or equal to 7m (Cutting)	1:0.5	Sandy soil or more stable	Guide bank	Apron with Cement Concrete Blocks	<ul style="list-style-type: none"> <li>Moderate slope at embankment side (30 - 35°) including revetment.</li> <li>To hold unstable mass at surface of fracture zone at cutting side.</li> <li>Concrete can be provided easily.</li> </ul>

Source: JICA Expert Team

Compound wall consists of wet-stone masonry and gravity wall with its height 7m ~ 12.5m is shown in the Figure 5-1 below and structural design calculation has been presented in Annex-8.

Guide bank with retaining earth and launching apron are showing in the Figure 7-1 with Compound wall consists of wet-stone masonry and gravity wall with its height 7m ~ 12.5m is shown in the Figure 7-2 and structural design calculation has been presented in Annex-8.

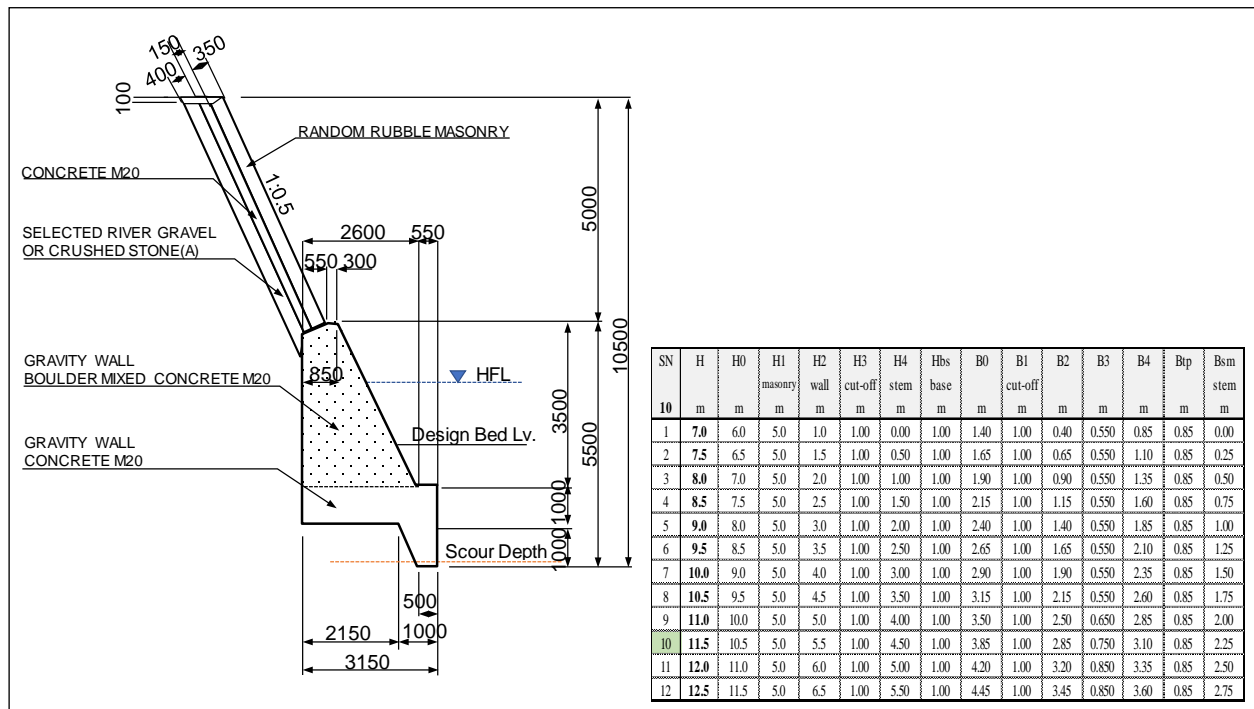

Figure 7-1 Designed Compound Wall

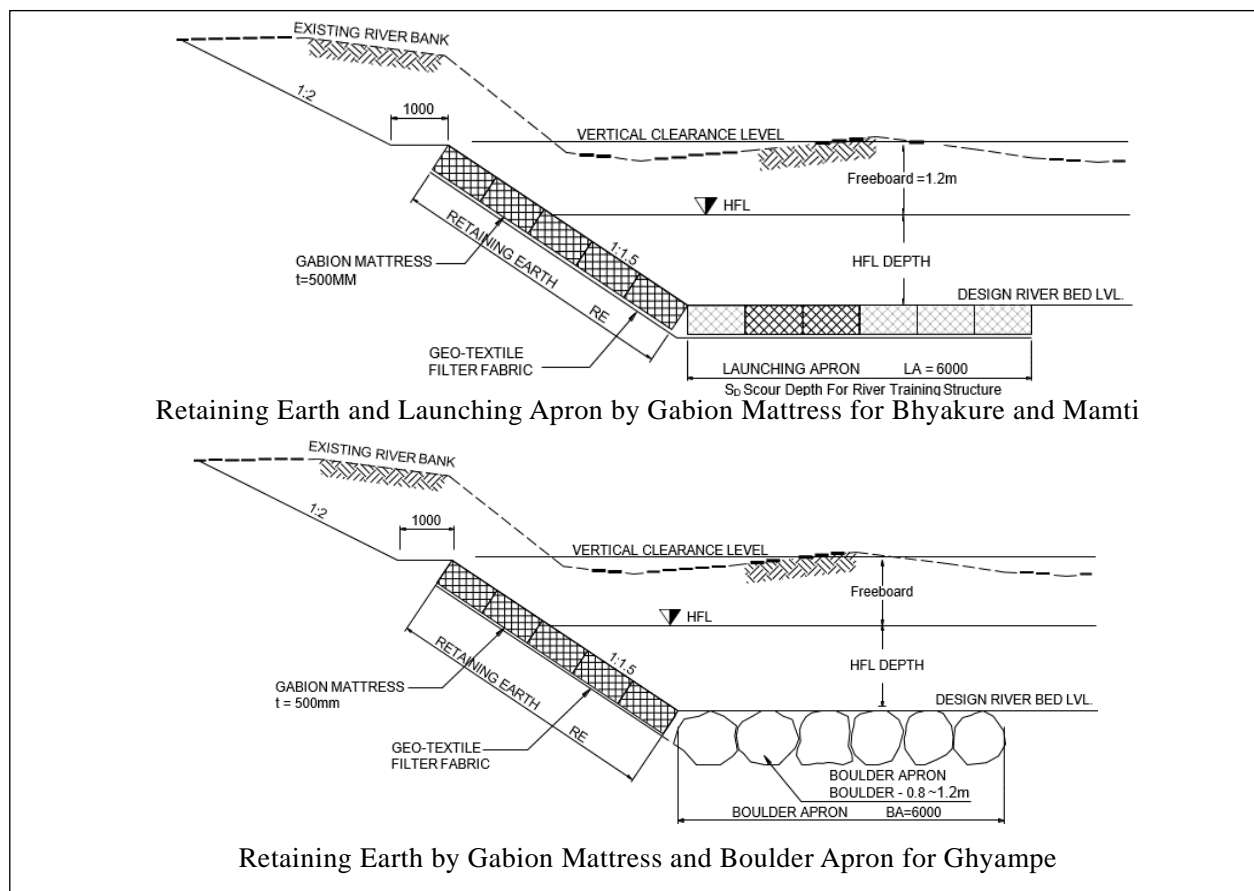

Figure 7-2 Designed Guide Bank

Table 7-7 Selection Criteria for Bed Protection for Scour Depth

Type	Size	Conditions
Launching Apron	Gabion mattress with thickness 0.3 ~ 0.5m	●Protection of the bridge at downstream side with 1.8 times of scour depth for river training
Bed Bar	RCC width 1~2m Depth 2m	●At the Uniform and constant slope channel will be not
Refilled Boulders	Boulder dia. 1~1.5m	●Boulder diameter around 1m to be procured at the waterway ●Boulders are interlocked under the riverbed level
Cast-in-situ plain concrete block	Thick 1.05m x 2m x 2.5m	●Hinge re-bar is connected between cast-in-situ concrete blocks and move to follow against scouring flexible
Gabion mattress	Thick 1.0m or 0.5m	

Where the road is to be constructed inside the river flood plain, the road surface level will be designed at a height considering margin for flood level and margin for rising of water level at curved flows as shown below. Compound wall with wet-stone masonry and concrete gravity wall with foot protection of cast-in-situ concrete as revetment will be adopted based on Sindhuli Road construction projects. To avoid outflow of back-fill, stable materials such as gravel will be used as back-fill materials up to the flood level and boulder stones at u/s area shall be used effectively for foot protection.

### 7.1.13 Design of the Floor Protection Works for River Training Structure and Bed Protection

#### (1) Launching Apron for Open Foundation and Guide Bank

The Clearance height of the river training structure basically can be defined the linear waterway at HF.

#### Launching Apron

Where,

$Q_P$  = Design Discharge at 50 years Return Period ( $m^3/s$ )

$D$  = Scoured Depth (m) at  $Q_P$

$t$  = Pitching thickness for Gabion Mattress or Boulder  $t = 0.06Q_P^{1/3}$  (m)

Used for Guide Bank Slope Pitching

$T$  = Unlaunched Apron thickness  $T = 1.9t$  (m)

Used for Launching Apron for Guide Bank and Open Foundation Bridge

$L_{APRON}$  = Length of Launching Apron  $L_{APRON} = 1.5D$  (m)

Used for Launching Apron for Guide Bank and Open Foundation Bridge

Table 7-8 Design of Guide Bank by Boulders

Tributary	50-year Return Period Flood flow $Q_P$ $m^3/s$	River Training Opening Width $W$ $m$	Velocity of flow at $Q_P$ $V$ $m/s$	Scoured Depth $D_S$ $m$	Pitching thickness $T=0.06Q_P^{1/3}$ $t$ $m$	Unlaunched Apron thick $T=1.9t$ $T$ $m$	Length of Launching Apron $=1.5D$ $L_{APRON}$ $m$	Adopted Min. Boulder Size		
								Stone Pitching Slope thick $m$	Boulder Apron thick $M$	Apron Length $length$ $m$
Ghyampe	371	40	7.9	3.2	0.43	0.82	4.8	0.5	around 1.0	6.0
Mamti	326	38	7.1	3.0	0.42	0.78	4.5	0.5	less amount	6.0
Bhyakure	391	40	6.6	3.2	0.44	0.84	4.7	0.5	less amount	6.0

Source: DWRI

Table 7-9 Design of Guide Bank by Flexible Gabion Mattress

Tributary	50-year Return Period Flood flow $Q_P$ $m^3/s$	River Training Opening Width $W$ $m$	Velocity of flow at $Q_P$ $V$ $m/s$	Scoured Depth $D_S$ $m$	Pitching thickness $T=0.06Q_P^{1/3}$ $t$ $m$	Unlaunched Apron thick $T=1.9t$ $T$ $m$	Length of Launching Apron $=1.8D$ $L_{APRON}$ $m$	Adopted Gabion Mattress Size		
								Slope Thick: $t$ $m$	Launching Apron Thick: $t$ $m$	Apron Length $length$ $m$
Ghyampe	371	40	7.9	3.2	0.43	-	4.8	0.5	0.5	6.0
Mamti	326	38	7.1	3.0	0.42	-	4.5	0.5	0.5	6.0
Bhyakure	391	40	6.6	3.2	0.44	-	4.7	0.5	0.5	6.0

Source: DWRI

The design of riprap revetments is governed by the nature of stream bank and hydraulic characteristics of stream at design flood. Design of riprap revetment is to adequately protect its toe from undermining by scour. Consideration of an appropriate size and weight of stone to be used in riprap is important for erosion and scour protection. The sizes of individual rocks are expressed by the dimensions of their three axes. The long axis, *a*, is the maximum length of the stone. The intermediate axis, *b*, is the maximum width, perpendicular to the long axis. The short axis, *c*, is the thickness of the stone perpendicular to the plane of the *a* and *b* - axes. The size of an individual rock is usually expressed as its *b*-axis dimension. The relationship of size to weight depends on stone shape and also on the specific weight or density of the rock. The density of rock used for riprap typically varies about 2,400 kg/m<sup>3</sup> to 2,800 kg/m<sup>3</sup> (source: *Riprap Design and Construction Guide, Public Safety Section, Water Management Branch, Province of British Columbia, Ministry of Environment, Lands and Parks, March 2000*).

Siebel (2007) tested the multiple configurations of flow discharge and bed slope to develop a relationship for the design of multi-layer riprap with including the factor of safety. The relation developed by Siebel (2007) to determine the average stone size (diameter) for riprap is as presented below (source: *R. Siebel, "Experimental investigations on the stability of riprap layers on overtoppable earthdams", Environmental Fluid Mechanics, Vol. 7, pp. 455-467, 2007*).

$$D_s = 1.71S^{0.68}Q_w^{2/3} \left[ \frac{\rho_w}{\rho_s - \rho_w} \right]^{1/3} \tag{7}$$

Where,

- $D_s$  = Mean stone diameter (m)
- $S$  = Riverbed slope (m/m)
- $Q_w$  = Flow per unit width (m<sup>3</sup>/s/m)
- $\rho_w$  = Density of water (1000 kg/m<sup>3</sup>)
- $\rho_s$  = Density of stone (2750 kg/m<sup>3</sup>)

The debris or boulders available on river area around the bridges construction sites in tributaries are made up of hard rock, therefore, density of the stone is considered as 2750 kg/m<sup>3</sup> to estimate the size of stone for the rip-rap. The estimated sizes of stones for riprap under different riverbed slopes are presented in Table 7-10 and Figure 7-3.

Table 7-10 Estimated Sizes of Stone for Rip-rap under Various Riverbed Slopes

Peak Flow (m <sup>3</sup> /s)	Bridge Width (m)	Q <sub>w</sub> (m <sup>3</sup> /s/m)	Rip-rap Size (m)						
			Riverbed Slope considered (%)						
			0.05%	0.10%	0.50%	1.0%	2.0%	5.0%	10%
359	38	9.45	0.036	0.058	0.173	0.277	0.443	0.827	1.325
409	38	10.76	0.039	0.063	0.188	0.302	0.484	0.902	1.445
431	38	11.34	0.041	0.065	0.195	0.313	0.501	0.934	1.497

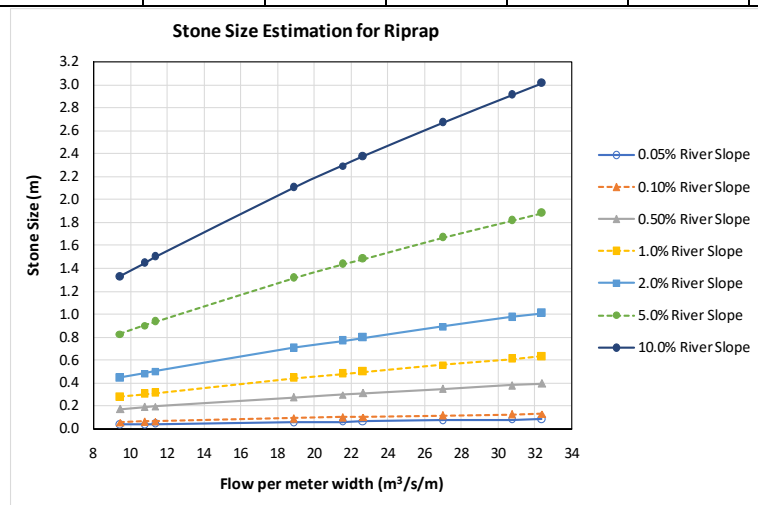

Figure 7-3 Size of Rip-rap Stones

- Structure of revetment higher than 5 m: Compound Wall (Wet-stone masonry + Gravity wall)
- Countermeasures against scouring:  
Considering maximum scouring depth and Foot protection by boulder (stone dia. around 1m) that is effective to movement and outflow of soils
- Thickness of boulder apron of scour floor protection : Boulder dia. 1 m considering flow velocity
- Length of floor protection: 6 m at the bed from base of guide bank slope

#### 7.1.14 Drainage Structure for Temporary Detour Operation

Temporary pipe culvert for detour road while construction is used for reference only.

Table 7-11 Scour Depth Calculation for River Training by IRC: 78-2014

Tributary	General Parameters			B=W	L	m D <sub>50</sub>	f	R <sub>s</sub>	D <sub>N</sub> = R <sub>s</sub> (W/L) <sup>0.61</sup>	Scour Depth below HFL 1.27 x D <sub>N</sub>	Embedded Depth by Scour 1.27xD <sub>N</sub> -y
	Q <sub>p</sub> 10-yrs m <sup>3</sup> /s	Q <sub>FL.3</sub> m <sup>3</sup> /s	y <sub>FL.3</sub> m								
Ghyampe	371	482	1.5	104.3	40	150	21.6	2.53	4.5	5.8	4.3
Mamti	326	424	1.4	97.8	38	150	21.6	2.40	4.5	5.4	4.0
Bhyakure	392	510	1.8	107.3	40	150	21.6	2.63	4.3	6.1	4.3

Source: DWRI

## 7.1.15 Approach Road

## (1) Design Criteria

The major design criteria based on the Nepal Road Standard 2013 (2070) shown in Table 7-12 will be applied for the approach embankment road design.

Table 7-12 Geometric Design Criteria for Approach Road and Bridge

Item	Standard	Approach Road	Bridge
Terrain classification	Rolling Terrain	Rolling Terrain	-
Highway classification	Class II	Class II	-
Design speed	40 km/hr (30 km/r)	40 km/hr (30 km/r)	-
Formation width	10 m	10 m	-
Carriageway	3.5 m x 2 = 7.0 m	3.5 m x 2 = 7.0 m	3.75 m x 2 = 7.5 m
Shoulder	1.5 m x 2 = 3.0 m		-
Footpath on bridge	-	-	1.5 m x 2 = 3.0 m
Pavement	-	Asphalt concrete 50 mm DBM 100 mm	Asphalt concrete Min. 50~75 mm
Sub-base and base	-	Base 200 mm Sub-base 300 mm	-
Cross fall	2 % at AC Pavement	2 %	refer to typical drawing
Vertical alignment Gradient	Maximum 9 %	4 % (desirable) 6 % (maximum)	Level
Minimum curve radius	70 m	70 m	Straight
Vertical curve Summit curves (Minimum)	K=29 at 40 km/hr K=4 at 30 km/hr	K=4 m/%	Level
Vertical curve Volley curves (Minimum)	K=17 at 40 km/hr K=6 at 30 km/hr	-	-
Sight distance	50 m at 40 km/hr	30 m	
Stopping distance (Minimum)	30 m at 30 km/hr		
Sight distance	300 m	-	
Overtaking distance (Minimum)			

Source: Nepal Road Standard 2070 and JICA Expert Team

The approach embankment road design has been carried out according to the design criteria as shown in Table 5-12. The length and slope grading of the planned approach roads are listed in below.

Bridge Name	Length and Grading of Approach Roads (m)		
	Right bank side (Nepalthok side)	Left bank side (Dhulikhel side)	Total length
Ghyampe	27.9 / 4%	39.2 / 4%	67.1 m
Mamti	115.3 / 6%	46.3 / 4%	161.6 m
Bhyakure	39.6 / 4%	32.7 / 4%	72.3 m

## (2) Pavement

Asphalt concrete pavement wearing course of 50 mm thick will be applied taking account of the existing road condition.

## (3) Slope Protection

Planting embankment approach road slopes is 1:1.5 and equal or less than 5 m height.

## 7.2 Cost Estimation

### 7.2.1 NORMS for Rate Analysis of Road and Bridge Works

The following basic approaches have been described in Norms for Rate Analysis as per Specifications of Road and Bridge Works (**Please Refer: NORMS for Rate Analysis of Road and Bridge Works 2075, DOR, MOPIT**)

The basic approach for the preparation of NORMS for Rate Analysis of Road and Bridge Works are as follows

#### (1) Description of Items

The description of items is given briefly and linked with the relevant Sections and Clauses of the Standard Specifications for Road and Bridge Works - 2073.

##### A. Labor:

Requirement of Labor in average working conditions are mentioned for each activity. Approved daily wages applicable to work site for corresponding item shall be used to find cost of Labor component.

##### B. Material:

Requirement of material in average working conditions are mention for each activity. Unit rate of material having specified quality at site (including transpiration up to site from available source (market/ quarry/ factory) shall be used to find cost of Material component.

##### C. Equipment:

- i. Due to mechanization of construction work inputs for various items have been indicated using mechanical means. However, manual means also can be select, where area is inaccessible for machines or quantity of work is not enough to justify use of machines.
- ii. Requirement of equipment in average working conditions are mention for each activity. Hire charge of equipment at work site (including transportation if not mention separately payable item) must be used to find cost of Equipment component. Hire charge shall include ownership charges and operation charges (Fuel component + crew component + maintenance component).

#### (2) Working Conditions

- i. Data in Norms are analyzed for average working conditions
- ii. Since, the outputs of machinery and Labor reduces substantially in maintenance works reduced outputs have been considered in corresponding activities of maintenance works.

### 7.2.2 Approved District Unit Rates

#### (1) Labor Wage Rates and Construction Materials Rates

For the purpose of Rate Analyses, the basic labor wage rates and construction materials unit rates have been referred and used as approved and provided by District Technical Office, Dhulikhel, Kabhre District for Fiscal Year 2076-77 (July 16, 2019 to July 15, 2020). The following assumptions are made while deciding the labor wage rates.

- The rates (wage rates) will be effective from July 17, 2019.
- The rates for labor, machines and equipment, and transportation have been fixed by this committee for FY2019-1920.
- Adjustment in transportation cost can be applied (in analysis) based on the distance from the Dhulikhel as center to other municipalities based on the distances.
- Regarding the materials not stated in this list, reference can be made from the respective government offices, or (if not available) from the manufacturers or official dealers.

- Please follow NOC for fuel related products.
- The executing agency must ensure the implementation of job security, health facilities, insurances and other safety related provisions to labors as per Public Procurement Act (PPA) and Public Procurement Regulations (PPR).

(2) Modification in Labor Wage as per the prevailing Provisions of Labor Act

In accordance to the requirements set forth by Labor Act 2048 (Revised edition 2074) and Labor Rules 2050, any enterprises (including construction Business Enterprise) must follow mandatorily the provisions in relation to the labor employed. The provisions from the Labor Act (and Rules) declare that every employee, including labor, under a continuous period of contract in construction site, shall be granted paid more than minimum labor wage considering holidays, e.g. public holidays, other social security payments, gratuity and termination allowances etc.

Therefore, as per the laws (Labor Act and Labor Rules), a minimum labor wage shall be modified and amplified with coefficient for cost estimate in design stage. Otherwise, the actual construction site condition would be different in reality and chance of disturbance during construction time cannot be ruled out. The effective coefficient while considering the provisions of prevailing Labor Acts have been calculated which is equivalent to 1.53 as presented in the Table 7-13 below. This coefficient has been adopted for Rate Analyses.

Table 7-13 Coefficient of Labor Wage Modification

S.N.	Description	Unit	Year	Remarks
1	Working Days	Days	360	
2	Holiday - one day as weekly Holiday for every week	Days	52	LA-'92 CL 16
3	Holidays - 45.5 days (public-13, home-12, sick-7.5, obsequies - 13 total 45.5 days)	Days	45.5	LR-'93 CL 28-34
4	Extra OT for 52 Saturdays with 50% extra Wage	Days	26	LA-'92 CL 19
5	Provident Fund @10%	Days	36	LR-93 Cl 26
6	Personal protective Equipment PPE (Safety Gears like Helmets, Boots, Gloves Goggles, Insurances etc. as per LA-'92 Clause-46 (a, b, c, d)	Days		By separate Contract Clause
7	Termination allowance @ 30 days/yr.	Days	30	Either One
8	Gratuity @ 8.33%	Days	30	LR-'93 Cl 23(a)
9	Total	Days	550	
	Equivalent Days for 12 months (12x30=360 days), 550 days need to consider. (550/360=1.526)		1.526	say 1.53

Source: JICA Expert Team

(3) Material Cost

The nearest market for construction materials (other than local materials like soil, sand, gravel, stones etc.) is Dhulikhel. Some materials will be brought from Kathmandu also. Local transportation cost including loading and unloading have been added to find the cost of materials at construction sites.

(4) Equipment

The equipment hiring charge given in Department of Roads' web site has been referred and cost of operation (manpower & fuel) etc. has been added in the ownership charges.

(5) Kabhre District and /or Sindhuli District

For Rate Analyses purpose, Ghyampe Khola (actually it is in Sindhuli District) has also been considered as of Kabhre District because of its close proximity to this district. So, all three proposed pilot sites are considered as of Kabhre District for estimate purpose.

**ANNEX 1**

**Letter (Minutes of Meeting)**



Minutes of Meeting  
for  
The Implementation of the Pilot Project  
on  
The Project for the Operation and Maintenance  
of the Sindhuli Road Phase 2

26<sup>th</sup> September 2019



Yumiko Asakuma (Ms.)  
Chief Representative, JICA Nepal office



Arjun Jung Thapa  
Project Director, Deputy Director General,  
DOR



Pradeep Thapa  
Deputy Director General, DWRI



Krishna Singh Basnet  
Executive Director, RBN

With regard to the Record of Discussion signed on 11<sup>th</sup> April 2018 (hereinafter referred to as the "R/D"), Japan International Cooperation Agency (hereinafter referred to as "JICA") and the Nepalese authorities had a series of discussion on measures to be taken by both sides for the successful implementation of the works as Pilot Project to demonstrate the restoration of damaged causeways (hereinafter referred to as the "Pilot Project") in "the Project for the Operation and Maintenance of the Sindhuli Road Phase 2" (hereinafter referred to as "the Project").

As result of the discussions, JICA and DOR side have agreed to the implementation of the Pilot Project with conditions as follows:

1. Original description of the Pilot Project in R/D

The R/D describes that two (2) or three (3) Pilot Projects for restoration of damaged causeways will be undertaken in the Section IV of the Sindhuli Road. It is also stated that JICA will bear the cost required for implementation of these Pilot Projects and DOR will bear the additional costs if required.

2. Decision of 1<sup>st</sup> JCC Meeting held on 25<sup>th</sup> April 2019

However, due to constrain of JICA budget, the JICA Expert Team suggested in the 1<sup>st</sup> JCC Meeting that JICA will carry out only one Pilot Project, and the remaining 1-2 sites are to be implemented by Nepalese funds by DOR as Priority Project, and DOR agreed to the suggestion of the JICA Expert Team. Meanwhile, DOR suggested that the specification of the Pilot Project and Priority Project should be bridge, not causeway, which should be designed in accordance with the Nepal design standard and specifications. Both parties also confirmed it in the 1<sup>st</sup> JCC Meeting.

3. Result of the Preliminary Evaluation

In line with decision of the JCC, the JICA Expert Team conducted the preliminary evaluation of the Pilot and Priority Projects taking into consideration not only DOR design standards but also natural conditions and effect of technology transfer, etc. as shown below.

No.	Candidate Sites		Restoration Structure	Status
1	STA. 1+400	Ghyampe Khola	RC continuous Slab Bridge and River Training	Pilot Project
2	STA. 3+900	Mamti Khola	RC continuous Slab Bridge and River Training	Priority Project
3	STA. 9+700	Bhyakure Khola	RC continuous Slab Bridge and River Training	Priority Project

JICA and DOR agreed to the above preliminary evaluation, however, the construction cost of Ghyampe bridge turned out to be NRs.80 million mainly due to the change in specification from causeway to bridge, which was far exceeded the budget of JICA funds and became difficult for JICA to implement the Pilot Project.

Handwritten signatures and initials are present at the bottom of the page, including a large signature on the left and several initials in the center and right.

4. Confirmation of the implementation structure for the Pilot Project

In order to solve this challenge, both JICA and DOR agreed that the restoration of three causeways shall be implemented by DOR as the Pilot Project and costs required for implementing be borne by DOR. Along with this, JICA shall not be responsible for implementation of the Pilot Project.

5. Contents of the assistance to be provided by JICA

Instead, both parties agreed that JICA will provide the technical assistance needed to carry out these Pilot Projects implemented by Nepal side smoothly and efficiently, which includes not only the soft component but also the training component as shown below:

(1) Soft component:

- Support for detailed design, cost estimation, preparation of tender documents, procurement of contractor(s), construction supervision, and so on.

(2) Training component:

- (i) Creation of a design manual of RC continuous slab bridge that will be applied to the Pilot Project (Mamti Bridge),
- (ii) Preparation of typical drawings of different span of RC continuous slab bridge (2 - 3 cases including Mamti Bridge),
- (iii) Training for users of manual, etc.

It is noted that the above technical assistance by the JICA Expert Team shall not be extended beyond the contract period of the Project.

6. Change of Bridge Type (Ghyampe bridge and Bhyakure bridge)

Since the site condition at the existing causeway changed significantly due to the abnormal heavy rainfall on July 10th to 14th, a joint survey by DOR and JICA expert team was conducted for July 29th to 30th. As a result, as shown in the table below, both parties agreed to change the two bridges, namely Ghyampe bridge and Bhyakure bridge, into a PC bridge with a single span instead of RC continuous slab bridge due to deep scouring and wide erosion of the downstream of crossing river.

The remaining Mamti bridge will be reconstructed with a RC continuous slab bridge as proposed by JICA Expert Team.

No.	Candidate Sites		Selected Type of Bridge
1	STA. 1+400	Ghyampe bridge	PC Post-tensioned T-girder (cast-in-situ) Bridge (40m)
2	STA. 3+900	Mamti bridge	RC continuous Slab (cast-in-situ) Bridge (40m)
3	STA. 9+700	Bhyakure bridge	PC Post-tensioned T-girder (cast-in-situ) Bridge (40m)

Handwritten signatures and marks at the bottom of the page, including a large signature on the left, a checkmark, a signature, the number 3, and another signature on the right.

Government of Nepal  
Ministry of Physical Infrastructure and Transport  
Singhadurbar, Kathmandu  
Nepal

**TERMS OF REFERENCE (TOR) FOR  
INITIAL ENVIRONMENTAL EXAMINATION (IEE)**

**OF**

**CONSTRUCTION OF THREE BRIDGES  
(GHYAMPE, MAMTI AND BHYAKURE)  
LOCATED BETWEEN CH. 111+400 ~ CH.119+700 KM  
OF BP HIGHWAY**

**Kavrepalanchowk and Sindhuli District,  
Province Bagmati, Nepal**

Submitted to  
**MINISTRY OF PHYSICAL INFRASTRUCTURE AND TRANSPORT  
SINGHADURBAR, KATHMANDU, NEPAL**

Through  
**GEO- ENVIRONMENT AND SOCIAL UNIT (GESU)  
DEPARTMENT OF ROADS, CHAKUPAT, LALITPUR  
NEPAL**

<i>Prepared by:</i> <b>GROUP OF ENGINEERS' CONSORTIUM (P). LTD. (GEC)</b> Shreemarg, Pulchowk, Lalitpur Phone: 977-01-5543979; 977-01- 5549382 Email: groupofengineers.gec@gmail.com	<i>Proponent:</i> <b>SURYABINAYAK-DHULIKHEL, DHULIKHEL-SINDHULI-BARDIBAS ROAD PROJECT</b> Min Bhawan, Kathmandu Telephone Number: 977-1-4481604 Email: pdadb@wlink.com.np
--	---

**March 2020**



## TABLE OF CONTENTS

1.	NAME AND ADDRESS OF THE PROPONENT WITH ORGANIZATION RESPONSIBLE FOR CONDUCTING IEE.....	1
1.1.	Name of the Proposal .....	1
1.2.	Name and Address of the Proponent.....	1
1.3.	Name of Consultant Preparing ToR.....	1
2.	GENERAL INTRODUCTION TO THE PROPOSAL .....	2
2.1	General introduction.....	2
2.2	Relevancy of the Proposal .....	2
2.3	Objectives of the proposal .....	2
2.4	Rationality for Conducting IEE Study.....	3
2.5	Objectives of the IEE Study.....	3
2.6	Objectives of ToR .....	3
2.7	Project Description .....	4
2.7.1	Salient features .....	4
2.8	Construction Materials .....	12
2.9	Construction Technology.....	12
2.10	Institution Involved in Project Implementation .....	12
2.11	Project Area Delineation.....	13
2.12	Existing environment of project area .....	13
2.12.1	Socio-economic environment .....	13
2.12.2	Cultural Environment .....	15
2.12.3	Physical Environment.....	15
2.12.4	Biological Environment.....	16
3.	PROCEDURE TO BE ADOPTED WHILE PREPARING THE REPORT .....	16
3.1	Data requirement for the study .....	16
3.2	Procedure for data collection.....	17
3.2.1	Desk Study.....	17
3.2.2	Field Study.....	18
3.2.3	Data analysis and Interpretation .....	19
3.2.4	Report Preparation and presentation.....	20
4.	POLICIES, LAWS, RULES AND MANUALS TO BE TAKEN INTO ACCOUNT WHILE PREPARING THE REPORT.....	20
5.	PREPARATION OF THE REPORT.....	23
6.	(DELETED BY FIRST AMENDMENT, GoN, 1999).....	24
7.	SPECIFIC IMPACTS/ ISSUES OF THE PROPOSAL ON THE ENVIRONMENT.....	24
7.1	Beneficial Impacts .....	24
7.2	Adverse Impacts .....	24

7.2.1	Socio-Economic environment .....	24
7.2.2	Culture Environment .....	24
7.2.3	Physical Environment .....	24
7.2.4	Biological Environment .....	25
7.2.5	Chemical Environment .....	25
8.	ALTERNATIVES FOR THE IMPLEMENTATION OF THE PROPOSAL .....	26
9.	MATTERS CONCERNING THE PREVENTION OF THE IMPACT OF THE IMPLEMENTATION OF THE PROPOSAL ON THE ENVIRONMNET (MITIGATION MEASURES) .....	26
10.	MATTERS TO BE MONITORED WHILE IMPLEMENTATION OF THE PROPOSAL (ENVIRONMENTAL MONITORING PLAN).....	27
11.	OTHER NECESSARY MATTERS .....	28
12.	IEE REPORT FORMAT .....	28
13.	REFERENCES.....	28

**APPENDICES**

- Appendix 1-1: Checklist for field survey
- Appendix 1-2: Household Questionnaires
- Appendix 1-3: IEE Study Team Members
- Appendix 1-4: Photographs

## **List of Tables**

Table 2- 1: Salient features of proposed project-Ghyampe Khola Bridge.....	4
Table 2- 2: Salient features of proposed project-Bhyakure Khola Bridge.....	5
Table 2- 4: Population Distribution of Project affected District .....	13
Table 2- 5: Population Distribution of Project affected Rural Municipalities .....	14
Table 5- 1: Proposed Work Schedule .....	23
Table 9-1: Beneficial Impacts, Augmentation and enhancement measures.....	27
Table 9-2: Adverse Impacts and Mitigation measures .....	27
Table 9-3: Summary of Enhancement and Mitigation measures Cost .....	27
Table 10-1: Monitoring Plan.....	28

## **List of Figures**

Figure 2- 1: Location Map of the Proposed Project .....	8
Figure 2- 2: General View of Ghyampe Bridge.....	9
Figure 2- 3: General View of Mamti Bridge.....	10



## ACRONYMS AND ABBREVIATIONS

<b>AC</b>	Asphalt Concrete
<b>Amsl</b>	Above mean sea level
<b>BP Highway</b>	Bisheswor Prasad Koirala Highway(NH 06 as Sindhuli Road)
<b>CSC</b>	Construction Supervision Consultant
<b>DCC</b>	District Coordination Committee
<b>DFO</b>	Division Forest Office
<b>DIZ</b>	Direct Impact Zone
<b>DWRI</b>	Department of Water Resources and Irrigation
<b>DoR</b>	Department of Roads
<b>IEE</b>	Initial Environmental Examination
<b>EIA</b>	Environment Impact Assessment
<b>EMP</b>	Environmental Management Plan
<b>EMoP</b>	Environmental Monitoring Plan
<b>EPA</b>	Environment Protection Act
<b>EPR</b>	Environment Protection Rules
<b>GESU</b>	Geo-Environment and Social Unit
<b>GoN</b>	Government of Nepal
<b>GoJ</b>	Government of Japan
<b>RoW</b>	Right of Way
<b>IIZ</b>	Indirect impact Zone
<b>IRC</b>	Indian Roads Congress
<b>JICA</b>	Japan International Cooperation Agency
<b>MoPIT</b>	Ministry of Physical Infrastructure and Transport
<b>NGO</b>	Non-Governmental Organization
<b>NTFP</b>	Non-Timber Forest Product
<b>PWD</b>	Public Works Directives
<b>RM</b>	Rural Municipality
<b>SRoM2</b>	The Project for the Operation and Maintenance of the Sindhuli Road Phase 2
<b>SSEMP</b>	Site Specific Environmental Management Plan
<b>TOR</b>	Terms of References



## **1. NAME AND ADDRESS OF THE PROPONENT WITH ORGANIZATION RESPONSIBLE FOR CONDUCTING IEE**

### **1.1. Name of the Proposal**

The Department of Roads (DoR) is the implementation agency of the Project and the proponent of the Initial Environmental Examination (IEE) study for construction of three bridges (Ghyampe Khola Bridge, Mamti Khola Bridge and Bhyakure Khola Bridge within 8.3 km section of BP Highway from chainage 111+400 km to chainage 119+700 km. The Physical Infrastructure and Transport (MoPIT) is the concern authority for the approval of IEE study.

The name of the proposed project is “Initial Environmental Examination Study of Construction of Three Bridges (Ghyampe, Mamti and Bhyakure) located between Ch. 111+400 ~ Ch.119+700 Km of BP Highway.

### **1.2. Name and Address of the Proponent**

The Proponent for the proposed project is Suryabinayak-Dhulikhel, Dhulikhel-Sindhuli-Bardibas Road Project under Department of Roads. The Department of Roads (DoR) is the leading agency for road development under Ministry of Physical Infrastructure and Transport (MoPIT) and is responsible for translating government policies for the road and bridges sub-sector into the provision of services. The services it provides include planning, design, construction and maintenance of the Strategic Road Network, and provisions to ensure a reasonable level of safety for all road users. The name and address of Proponent is presented hereunder.

#### The Address of the Proponent

The Department of Roads,  
Suryabinayak-Dhulikhel, Dhulikhel-Sindhuli-Bardibas Road Project  
Min Bhawan, Kathmandu  
Telephone/ Fax No: +977-1-4481604

### **1.3. Name of Consultant Preparing ToR**

Name of the consultant for preparing ToR for this IEE report is Group of Engineers’ Consortium (P). Ltd. (GEC).

#### The Address of the Consultant

Group of Engineers’ Consortium (P). Ltd. (GEC)  
Shreemarg, Pulchowk, Lalitpur  
Phone: 977-01-5543979; 977-01- 5549382  
Email: groupofengineers.gec@gmail.com

## **2. GENERAL INTRODUCTION TO THE PROPOSAL**

### **2.1 General introduction**

The Bardibas – Sindhuli – Dhulikhel Road, (BP Koirala Highway or Sindhuli Road) which is classified as the National Highway, NH 06, is one of the most important strategic roads to link Kathmandu Valley with the eastern Tarai. The road is also known as BP Highway, total length of 160km, connects Dhulikhel on the Araniko Highway (31km eastward from Kathmandu) to Bardibas on the East-West Highway crossing the Tarai Plain. The construction of Banepa Sindhuli Bardibas Road started in November 1996 with a grant assistance of Government of Japan (GoJ). GoJ has provided Grant Aids - non-reimbursable fund to Government of Nepal (GoN) for newly construction of the Sindhuli Road (Banepa - Sindhuli - Bardibas Road between 1995 and 2015 to procure the facilities, equipment and engineering services for the economic and social development of GoN. The Japan International Cooperation Agency (JICA) is the executing agency of the Technical Assistance conducted the Project for the Operation and Maintenance of the Sindhuli Road in 2012~2015 for the construction of the last section of the Road.

Under the project ‘Operation and Maintenance of the Sindhuli Road Phase 2’ of Banepa – Sindhuli – Bardibas Road, the construction of Ghyampe Khola Bridge, Mamti Khola Bridge and Bhyakure Khola Bridge along the road from Ch 111+400~Ch 119+700 Km is proposed. The design is being designed as per the latest Guideline, Standards Codes of Practice (Nepal Bridge Standard 2067) and National Highway (NH06). The proposed bridges will be designed in double lane with Black top (asphalt concrete).

The construction of the approach roads of the three bridges over Ghyampe, Mamti and Bhyakure Khola within 8.3 km section of the road of Nepalthok Dhulikhel section of the BP Highway. Among three bridges Ghyampe and Bhyakure Khola Bridge are categorized as major bridge while Mamti Khola Bridge falls on minor bridge category.

### **2.2 Relevancy of the Proposal**

The existing cause way over Ghyampe Khola, Mamti Khola and Bhyakure Khola has been eroded due to several flooding which results in the deflection in the road section. Since the Bardibas – Sindhuli – Khurkot–Dhulikhel Highway is being used as an alternative route connecting the capital with the Tarai plains, the traffic flow has been increases exponentially. Especially during rainy season, the traffic flow has been experienced halt at Sindhuli Road at different causeway sections for few minutes to several hours. The need of construction of bridges including approach road replacing the existing cross drainage structure over mentioned stream seem essential for ease traffic flow along BP Highway.

Moreover, construction of new double lane bridges with approach roads in the Nepalthok – Dhulikhel Section will significantly contribute in the improvement of the socio-economic condition of the project districts and Nepal at larger scale. This improved access will also attract other development infrastructures and open door to further development opportunities in the area.

### **2.3 Objectives of the proposal**

The objective of the proposal is IEE study of the construction of major bridges to restore the damaged causeways between CH 111+ 400~Ch 119+700 in the Bardibas– Sindhuli – Khurkot - Dhulikhel Road. The proposed study will also be applicable for minor bridge along the section too. The new bridges will be of two lane standard with Asphalt Concrete pavement as per the DoR standard.

## **2.4 Rationality for Conducting IEE Study**

As per Environment Protection Rules (EPR) 1997, construction of a major bridge requires an IEE and its subsequent approval from its concerned ministry (Clause-D-4 of Road Sector, Schedule-1 Pertaining to Rule-3 of EPR). National Bridge Standard 2010 classifies a bridge as a major bridge when its span is more than 25 m long or the total length of the bridge is more than 50 m.

The span of the proposed Ghyampe and Bhyakure Khola bridges is 40 m each and hence, the proposed construction work requires IEE.

## **2.5 Objectives of the IEE Study**

The main objective of this IEE Study is to identify the impacts of proposed project implementation on physical, biological, socio-economic and cultural environment of the sub-project area and propose mitigation measures to avoid or mitigate such impacts.

The specific objectives of the proposed IEE study are:

- To establish baseline information on the physical, biological, socio-economic and cultural aspects of the project area;
- To identify the major beneficial and adverse impacts that may arise as a result of proposed work on physical, biological, socio-economic and cultural environment of the project area;
- To propose practical and site specific environmental mitigation and enhancement measures, prepare environmental monitoring plan for the project;
- To provide information to the decision makers regarding further action and about the environmental implications from the implementation of the proposed project;
- To allow project proponent, designers, implementing agencies, and funding agencies to address environmental issues in a timely and cost effective manner during the feasibility stage of the project;
- To provide an opportunity of public involvement in the planning stage of the project;
- To define the institutional framework required for the execution of monitoring and management programs; and
- To make sure that IEE is sufficient or not for the proposed project.

## **2.6 Objectives of ToR**

The objective of ToR is to provide a guide for the preparation of IEE report and produce a comprehensive and coherent IEE report.

The basic objectives of ToR are as follows:

- Systematizing the IEE working procedures in compliance with the EPA'97, EPR'97 as amended and other sectorial policies and legislations
- Accomplishing the IEE study in the stipulated timeframe with professional skills
- Delineate the scope of work for IEE study i.e. Identification of the environmental impacts on the physical, chemical, biological and socio-economic and cultural environment of the proposed project area and produce appropriate, site specific mitigation measures and enhancement measures

## 2.7 Project Description

One of the Scope of the Operation and Maintenance of the Sindhuli Road Phase 2 is to restore the damaged causeways of Sindhuli Road with JICA Expert Team's technical support for planning, design, tendering and supervising.

Ministry of Physical Infrastructures and Transport (MoPIT) under Government of Nepal (GoN) is the responsible organization for executing the Project and DoR is the implementation agency. The Three (3) damaged sites of the causeway were recognized in 2017 through the Pre-survey for the Project for the Operation and Maintenance of the Sindhuli Road Phase 2 is being undertaken at present by JICA to provide a set of basic documents necessary for the appraisal of the Project.

During implementation of the Project, the GoN is required to undertake necessary measures for environmental and social considerations. This Terms of Reference (ToR) is prepared to conduct an IEE study for the implementation of the major bridges i.e. Ghyampe Bridge and Bhyakure Khola Bridge construction including minor Mamti Khola Bridge construction.

### 2.7.1 Salient features

The salient features of proposed construction of three bridges is given in Table 2.1 and 2.2. General view of proposed bridges are shown in Figure 2-2, 2-3 and 2-4 below.

**Table 2- 1: Salient features of proposed project-Ghyampe Khola Bridge**

<b>Bridges</b>	<b>Ghyampe Khola Bridge</b>
<b>Locations</b>	
Province	Bagmati
Zone	Bagmati
District	Kabhre
Municipality / RM	Roshi Rural Municipality
Name of the Road:	B. P. Highway, NH06 (Sindhuli Road)
Origin and Destination of the Road	Bardibas - Dhulikhel
Chainage of the bridge site	CH.111+400
Easting	381,774.00
Northing	3,035,404.00
Classification of Road, Class, Lane	National Highway, H06 Class A, Intermediate Lane
Type of the road surface	Black Top (Asphalt Concrete)
Terrain / Geology	Mountain & Steep Terrain
Total Bridge Length	40 m
Span arrangement	Single Span
Bridge length (c/c of exp. Gap)	40 m
Span lengths (c/c of bearing)	40 m
Total width of the bridge:	11 m
Cross slope	Cross fall 0.71% - 0.71%
Profile	Flat
Carriageway:	3.75 m X 2 = 7.5 m
Overall width of Bridge	11 m

<b>Bridges</b>	<b>Ghyampe Khola Bridge</b>
Footpath(s):	1.5m at both sides Footpath Loading corresponding to 500 kg/m <sup>2</sup> of Footpath area as per Clause 206.3 of IRC-6 (2014). (Live Load Conditions)
<b>Type of superstructure:</b>	PC Post-tensioned 2-Webbed-Slab (depth 3.0 m) Cast-in-situ on all staging (by Standard Drawing) Single Span 40 m Reverse T-shape RC Abutment x 2
Type of abutments:	Reverse T-shape RC Abutment x 2
Design discharge	408 m <sup>3</sup> /s
Effective Linear waterway	38 m
Design Speed	40 km/hr
Earth works excavation in Foundation	700 cum
Earth works excavation in River training	14000 cum (including catchment Pit)
Filing volume Required	500 cum

Source: Feasibility Study Report, 2019

**Table 2- 2: Salient features of proposed project-Bhyakure Khola Bridge**

<b>Bridges</b>	<b>Bhyakure Khola Bridge</b>
<b>Locations</b>	
Province	Bagmati
Zone	Bagmati
District	Sindhuli
Municipality / RM	Sunkoshi Rural Municipality
Name of the Road:	B. P. Highway, NH06 (Sindhuli Road)
Origin and Destination of the Road	Bardibas - Dhulikhel
Chainage of the bridge site	CH.119+700
Easting	376,564.00
Northing	3,039,060.00
Classification of Road, Class, Lane	National Highway, H06 Class A, Intermediate Lane
Type of the road surface	Black Top (Asphalt Concrete)
Terrain / Geology	Mountain & Steep Terrain
Total Bridge Length	40 m
Span arrangement	Single Span
Bridge length (c/c of exp. Gap)	40 m
Span lengths (c/c of bearing)	40 m
Total width of the bridge:	11 m
Cross slope	Cross fall 0.71% - 0.71%
Profile	Flat
Thickness of wearing course	Asphaltic concrete wearing course, 75mm thick at

<b>Bridges</b>	<b>Bhyakure Khola Bridge</b>
	roadway crown, gradually reducing to 50mm at the road kerb, shall be provided over the deck slab
Carriageway:	3.75 m X 2 = 7.5 m
Overall width of Bridge	11 m
Footpath(s):	1.5m at both sides Footpath Loading corresponding to 500 kg/m <sup>2</sup> of Footpath area as per Clause 206.3 of IRC-6 (2014). (Live Load Conditions)
<b>Type of superstructure:</b>	PC Post-tensioned 2-Webbed-Slab (depth 3.0 m) Cast-in-situ on all staging (by Standard Drawing) Single Span 40 m Reverse T-shape RC Abutment x 2
Type of abutments:	Reverse T-shape RC Abutment x 2
Design discharge	431 m <sup>3</sup> /s
Effective Linear waterway	38 m
Design Speed	40 km/hr
Earth works excavation in Foundation	700 cum
Earth works excavation in River training	14000 cum (including catchment Pit)
Filling Volume Required	500 cum

Source: Feasibility Study Report, 2019

#### **Estimated Cost**

The overall cost of the project is NRs 3.45 Million.

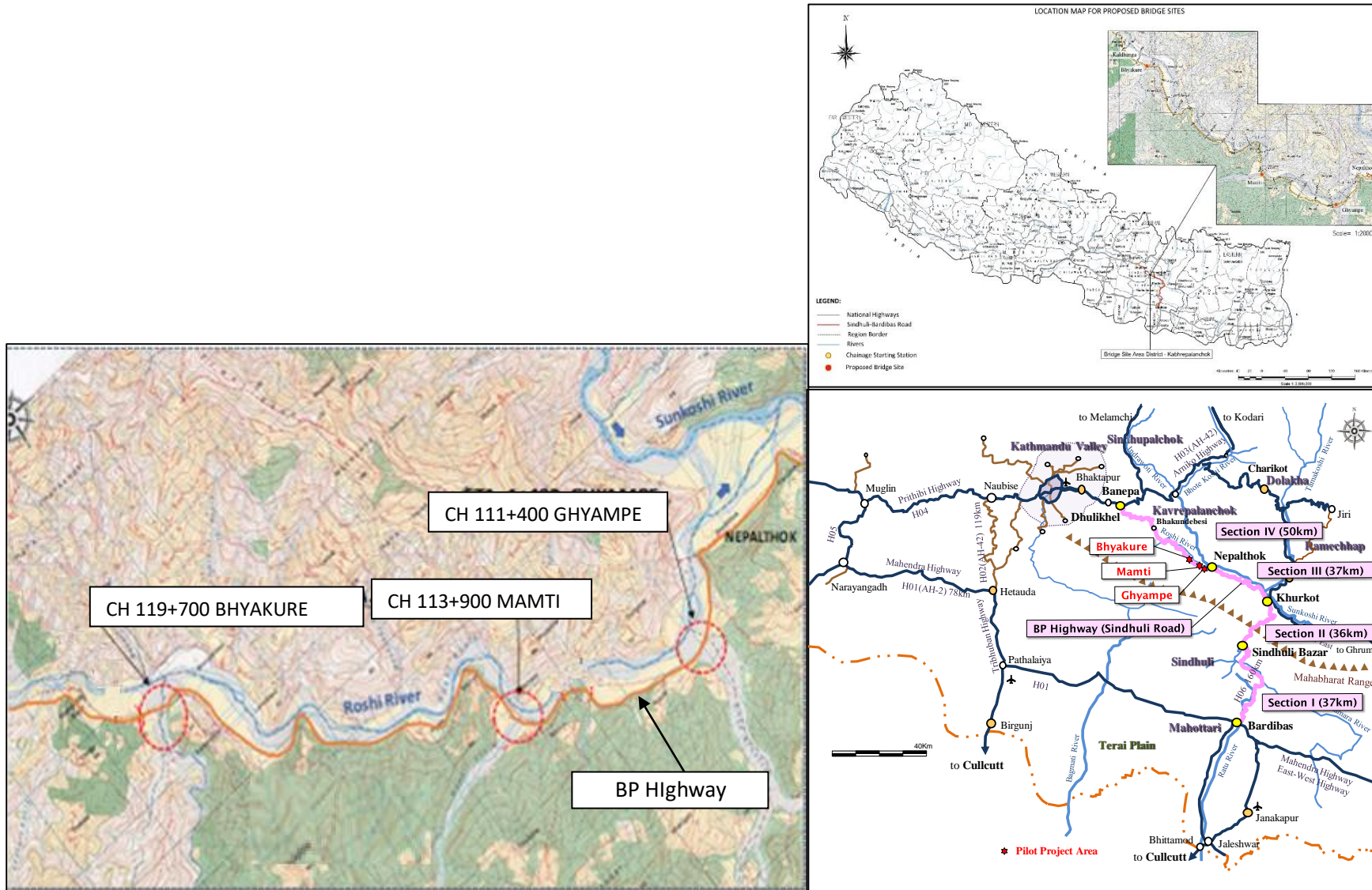
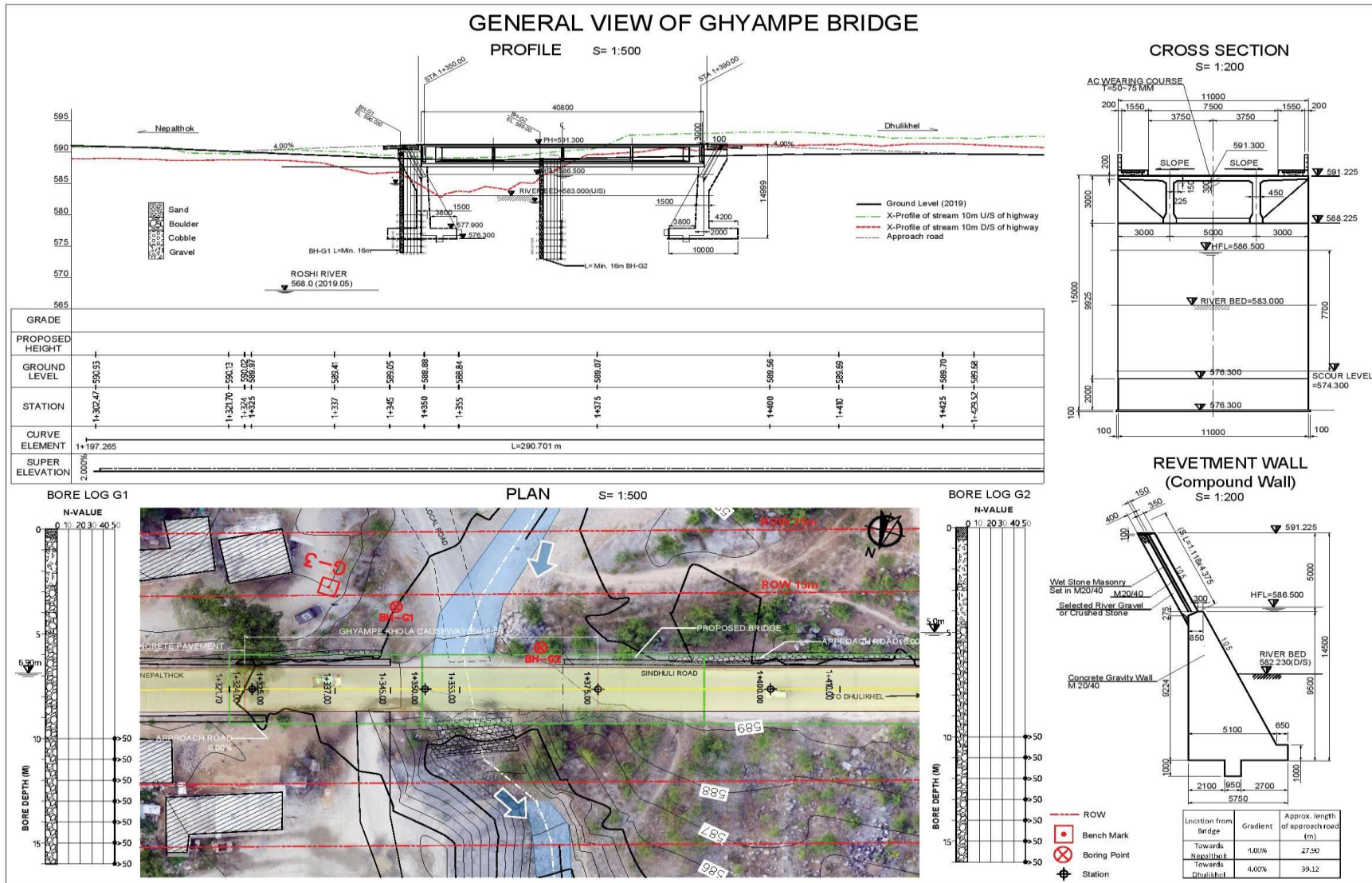
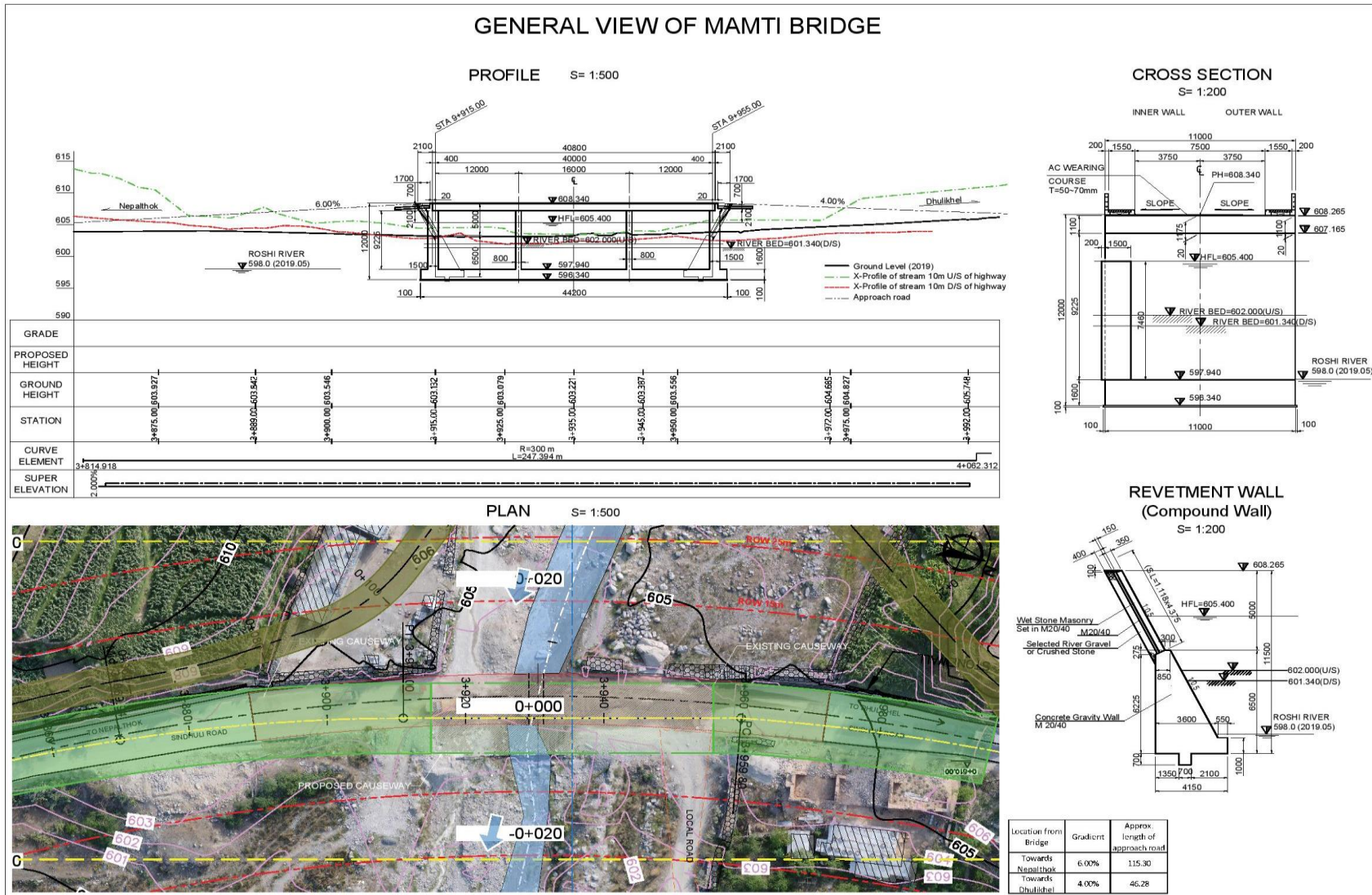

Figure 2- 1: Location Map of the Proposed Project



**Figure 2- 2: General View of Ghyampe Bridge**



**Figure 2- 3: General View of Mamti Bridge**

## **2.8 Construction Materials**

Local construction materials required for construction of the project road are sand, aggregates, boulders and asphalt concrete aggregates for base course, sub-base course and surface dressing. The quarry sites and borrows pits for construction materials are from the existing operational quarries, situated within 10 km stretch of project area.

The contractor will be responsible for the reinstatement of the quarry/ borrow sites to the satisfaction and with payment of royalty and taxes for the operation of the quarry/ borrow sites. The contractor will be responsible for the preparation of reinstatement plan and its procedures for individual quarry sites/ borrow areas to carry out after completion of work. The reinstatement plan of the quarry sites and borrow areas will include the protection of river bank with gabion protection mattress and gabion wall and other normal practice such as tree plantation and bio- engineering (as provision in reinstatement plan). Proponent and project will also closely monitor the contractor doing such activities.

The equipment and vehicles required for the extraction of construction materials are excavators, bulldozers, loaders, tippers, trucks, tractors, shovel, crusher plant, screen plant, etc. All such contractor's operation and reinstatement plans will have to be approved by the implementing agency prior to execute the quarry.

## **2.9 Construction Technology**

The technology used for the construction work will be both machine and labor based. Machine based method is mainly used for specialized works like use of lifting and lowering of heavy loads – precast beams, entire structural elements, roofs, false work, etc. for bridge constructions, vibrator for surface laying and compacting, use of distributor for laying and use of compactor for finishing bituminous seal etc. whereas labor is mainly employed for the manual work like earthwork, construction of side drain, bioengineering etc.

For work of labor based, local people will be given priority if, when and where their sustained availability is assured to be employed such as:

- Using of light equipment, masonry works,
- Balancing cut and fill and reuse of excavated materials as construction materials, and thus not generating excess spoils as far as possible
- Bio-engineering works: integrated use of vegetation and simple civil engineering structures for slope protection.

The construction equipment to be used during implementation are excavator, bulldozers, loader, tripper, cranes, trucks, tractors, crusher plant, screen plant, concrete mixer, asphalt plant, paver, bitumen heater, bitumen distributor, vibrator, roller, generator, road marking machine, concrete cutter, etc.

## **2.10 Institution Involved in Project Implementation**

Department of Roads (DoR) will be the government institution involved in the implementation of the project. During Construction, MoPIT, DoR/GESU, and Project Implementing Unit (PIU) will carry out internal monitoring of the environmental compliance carried out by the Contractor while the Supervising Consultant. During operational phase MoPIT and DoR/GESU will again carry out monitoring of the project.

DoR will depute a project team comprising Project Manager, Engineers, Environmental Expert and other support staff to implement and manage the project. The Project Manager will be assisted by the consultant, if appointed by DOR. The consultant will have the responsibility of construction supervision and contract administration of civil works contracts to be executed

by contractors. There will be contractors involved in construction of this road upgrading works. The contractor will have its own site organization responsible for construction activities as per the contract agreement. Local people will be given priority to be involved in labor intensive works. Non-Governmental Organization (NGOs)/ Community Based Organization (CBOs) will be involved in social safeguard activities.

## 2.11 Project Area Delineation

### Direct Impact Zone (DIZ)

The direct impact area is the zone where a concentration of direct impacts is expected; i.e. the zone that will suffer the greatest impact during the construction works, including the movement of workers, and equipment during the construction phase, and changes arising from project execution. The Right of Way (RoW), Corridor of Impact (COI)/ formation width as well as project utilities locations where project activities takes place and from which direct impact on the surrounding environment is expected are included under the DIZ. The RoW of the project is 25 m on both side from the center line of the road. COI or formation width is the area where upgrading work is being carried out i.e 11 m. It includes ward no. of 1, 11 and 12 of Roshi Rural Municipality and ward no. of 11 of Sunkoshi Rural Municipality.

### Indirect Impact Zone (IIZ)

IIZ for the proposed project road will be the adjoining wards of concerned municipality beyond the DIZ. Here, the physical and biological impacts will be minimal with respect to socio-economic impact especially due to pressure on the social facilities by influx of large number of construction crews working in the project. It includes ward no. 2, 3, 10 of Roshi Rural Municipality and ward no. 10 and 12 of Sunkoshi Rural Municipality.

### Zone of Influence (ZOI)

The zone of Influence of the proposed project bridge consists of Roshi and Sunkoshi Rural Municipality.

## 2.12 Existing environment of project area

### 2.12.1 Socio-economic environment

The description of existing Socio-economic and Cultural Environment of Kavrepalanchowk and Sindhuli District is presented in this section hereunder. The data are based on the record of District Profile of Nepal 2011.

#### *a. Demographic Pattern*

According to the Census 2011 (CBS), total population of Kavrepalanchowk and Sindhuli Districts are 381,937 and 296,192 respectively. Gender-wise population distribution is estimated to be 47.89% male and 52.10% female in Kavrepalanchowk District and 31.52% male and 68.47% female in Sindhuli District. The details have been given in Table 2.4.

**Table 2- 3: Population Distribution of Project affected District**

District	Total HHs	Total Population	Male	Female	Average HH Size
Kavre	80,720	381,937	182,936	199,001	4.73
Sindhuli	57,581	296,192	93,386	109,260	5.14
<b>Total</b>	<b>138,301</b>	<b>678,129</b>	<b>276,322</b>	<b>308,261</b>	<b>4.90</b>

Source: District Development Profile of Nepal, CBS, 2011

The proposed area for the construction of Ghyampe and Mamti Khola Bridge is in Roshi Rural Municipality of Kavre district and Bhyakure Khola Bridge is in Sunkoshi Rural Municipality of Sindhuli District. The detail population distribution is given in Table 2.5.

**Table 2- 4: Population Distribution of Project affected Rural Municipalities**

District	Rural Municipality (RM)	Total HHs	Total Population	Male	Female
Kavre	Roshi RM	5,896	28,746	13,531	15,215
Sindhuli	Sunkoshi RM	4,557	2,473	9,988	11,485
<b>Total</b>		<b>10,453</b>	<b>31,219</b>	<b>23,519</b>	<b>26,700</b>

Source: District Development Profile of Nepal, CBS, 2011

*b. Ethnicity/Caste*

The majority of ethnic groups living in Kavre district is Tamang (34.01%) followed by Brahmin-Hill (21.53%). Similarly 28.87% Tamang resides in Sindhuli District followed by 14.90% Magar ethnic groups (Source: National Population and Housing Census, 2011). The detailed household survey will be carried out and the output data will be incorporated in the IEE report.

*c. Religious population*

Hindu is the largest predominant religious group in the project area with 82.57% and 68.56% religious population in Kavrepalanchowk and Sindhuli district respectively. It is followed by 34.52% and 28.09% Buddhism population respectively. Islam, Jain Christian and Sikh are the minority religious population with less than 1% in both districts

*d. Literacy Rate*

The literacy rate of Kavrepalanchowk and Sindhuli districts are almost same i.e. 69.8% and 70.0% respectively. However, the percentage of population acquiring higher education is very low in both districts.

*e. Education Status*

There are total 570 preprimary, 690 primary schools, 316 lower secondary schools, 202 secondary schools and 82 Higher Secondary Schools in Kavrepalanchowk District. Similarly, there are total 411 pre-primary schools, 550 primary schools, 206 lower secondary schools, 107 secondary schools and 56 Higher Secondary Schools in Sindhuli District.

*f. Health Service*

In Kavrepalanchowk district, there are 2 hospitals, 9 health posts, 90 sub-health posts and 3 institutional hospitals. Health service in Kavrepalanchowk district is provided by Dhulikhel Hospital which is near to the starting point of the Bardibas-Dhulikhel Road.

Similarly, the major health facilities in Sindhuli district are provided by 1 hospital, 17 health posts and 35 sub health posts.

*g. Water Supply and Sanitation*

In the Kavrepalanchowk 77.22 % of the households have toilet facilities (Modern and Ordinary toilet). Those who have toilet mostly possess either pan or pit type toilet with flush system. Different scenario can be observed in Sindhuli district where 66.45% of total HHs are without sanitary facilities. Only 33.15% of total HHs have toilet facilities.

Major source of drinking water is found to be from piped water supplies i.e.79.15% in Kavrepalanchowk district and 58.08% in Sindhuli District. Other source of drinking water includes well, hand pump, spout water and river stream in both districts.

*h. Energy*

Majority of populations depend on firewood as means of source for cooking in both districts which accounts 78.23% and 90.96% in Kavrepalanchowk and Sindhuli districts respectively. 87.31% of total HHs use electricity as main source of lighting while only 37.87% accounts in Sindhuli district.

**2.12.1 Cultural Environment**

The proposed area does not contain any significance cultural, religious and historical place. There will be no impact on cultural environment from the implementation of the project.

**2.12.2 Physical Environment**

*a. Land Use and Topography*

The land area in the project districts is categorized into three different types; High Mountain, Mid Mountain and Siwalik. Total cultivated land in Kavre district is 36,442 Ha and the forest area covers 73,801 Ha of the total district area. The total land area of the district is 140,486 Ha. Similarly, total cultivated land in Sindhuli district is 39,484 Ha and the forest area covers 178,130 Ha of the total district area. The total land area of the district is 247,709 Ha.

The project area is located in the existing road of Nepalthok – Dhulikhel section.

*b. Geology*

The project area is located in the northwest slope of Mahabharata Mountain Range that has been formed by successive geo-tectonic movement in Tertiary. The geology of the project site consists of Pre-Cambrian schistose rocks. The schistose rocks are generally hard, less to slightly fractured at outcrop but locally very intensely fractured and sheared

*c. Climatic condition*

The project area does have a moderate type climate. Based on the meteorological data obtained from Sindhuli Gadhi, the average highest temperature is 31.7 °C in April while the average lowest is 7.2 °C in January. Meanwhile, annual rainfall in Nepalthok is 887mm with average largest of 296.3mm in July, and average least of 9.0 mm in November. The period between late May and early October is deemed as monsoon season

*d. Air, Water and Noise*

The project area does not have any source of pollution industry of the establishment that would deteriorate the air quality, water quality or noise pollution. The noise and air pollution could be from the heavy traffic flow in BP highway that will be plying on the road. In other words, the project area is pristine from the environmental condition. However, the air, noise and water sampling will be carried out during detailed IEE study.

*e. Quarry Sites*

As per the materials survey, the local material quarries for the construction materials will be 10 km within the vicinity of the project road in the tributaries, at the extraction areas of the existing operational quarry site. Construction materials like Concrete aggregates, stone sand and asphalt concrete chips will be extracted from Ghyampe, Mamti and Bhyakure Khola itself as stated in above sentence. Other physical parameters like seismicity, slope stability, etc will be discussed more detail in the upcoming IEE report.

### 2.12.3 Biological Environment

The proposed area does not pass through any protected or buffer zone area or reserve forests. The project area is in built up area of ribbon settlement area and cultivated land. The project area is located in mid-hills (sub-tropical and temperate) ecological zone. The road side trees species found are Utis (*Alnus nepalensis*), Sisoo (*Dalbergia sissoo*), Chilaune (*Shima Wallichii*), etc. Virtually no wildlife and wild animals of significance were noted within the project area. Some domestic animals like cows, goats are seen during the field visit. Similarly, Crow (*Corvus splendus*), Eagle (*Haliaeetus leucocephalus*), Sparrow (*Passeridae*), Pigeon (*Columba livia*) like birds are reported in the proposed project area.

Ghyampe, Mamti and Bhyakure Khola are the major sources of habitat for different type of fish species. It offers habitat for cold water fishes. Inquiries were made with local people on availability of fish species into the streams, they were responded that other streams offer habitat for limited species of fishes like Asala (*Schizothorax* spp) and capre (*Glyptothorax* spp), Titemachha (*Psilorhunchoides pseudecheneis*), Katle (*Neolissoc heilushexagonolepis*), Bam (*Monopterus cuchia*) and Sahar (*Tor tor*).

## 3. PROCEDURE TO BE ADOPTED WHILE PREPARING THE REPORT

The IEE approach, methodology and procedure should generally follow the provisions of the EPR 1997 (Rules 5, 7, 10 & 11 in compliance with schedules 1, 3 and 5).

In this connection, following approach and methodology will be adopted during the IEE report preparation.

### 3.1 Data requirement for the study

In order to meet the objectives of IEE, primary and secondary information will be collected through literature review and field studies. The primary data will be collected employing the following techniques: Focus group discussions, field observation, and walkthrough along the proposed bridge area. Secondary information will be collected from project related documents, reports, maps, designs and cost estimates.

Following data related to Physical, Biological, Socio-economic, Cultural and Chemical environment will be collected.

#### a. Physical Environment

Information on physical environment will be collected from visual observation, field investigation, laboratory analysis, maps, etc. Extensive observation on topographical features and drainage characteristics will be observed and documented. Physical features comprising soil characteristics, slope stability will be observed and recorded during walk through survey, field survey. Key informant interview, consultation with local communities will be carried out to know the history on natural disasters like landslides, earthquakes, etc.

#### b. Biological Environment

Information on the flora and fauna, protected, rare and endangered species, sensitive habitats and species of commercial importance in the project area will be collected. Documentation on (i) wildlife in the project site including mammals, birds, reptiles and amphibians and (ii) the habitat for sensitive species of birds and mammals known in the study area.

Number of trees to be cleared if any for implementation of the project will be recorded by counting method. Documentation of vegetation status, forested area, distribution of endangered plants, medicinal plants, non-timber forest product (NTFP), regionally scare plants and plants with other cultural values will be made.

Vegetation and forest resources assessment will be done with the use of the sampling survey with quadrates method as well as observation walk through survey. Plant species identified in the influence area will be compared to the list prepared by IUCN Red Data Book, CITES and List of Endangered Rare and Threatened Plant Species published by GoN. Likewise, information about the private trees on the farm land will be collected by making walkthrough survey, key informant interview along the alignment.

All the tree and poles species found will be noted in a standard data sheet. Diameter at Breast Height (DBH), height (total height and timber height) will be measured on the basis of standard format.

However, affected trees along the project road alignment will be counted individually, recorded with GPS points and will be noted in a standard data sheet. DBH of the affected trees will be measured on the basis of standard format. Average height, coverage percentage and number of plant species will be enumerated for shrub species. Number of plant species, their number and ground coverage will be enumerated for herb species.

The volume of the affected tree species will be quantified together with the loss of forest. Tree species having more than 30 cm diameters at breast height (DBH) will be counted and measured as tree. Tree species having DBH range between 10 cm – 30 cm will be counted and measured as pole and rest will be counted as seedling and saplings. Diameter at breast height (d) will be measured at 1.3 meter from the ground level.

The data from tree measurements will be quantitatively analyzed for basal area and to calculate the wood volume. Basal Area is the trunk cross-sectional area. The basal area of each of trees will be calculated on the basis of diameter at breast height. These parameters will be calculated by using following formulae:

$$\text{Basal Area} = \Pi d^2/4 \quad \text{and}$$

$$\text{Volume} = \text{Basal Area} \times \text{Tree height} \times \text{Form factor (0.50)} \text{ [m}^3\text{]}$$

### **c. Chemical Environment**

Use of chemicals for construction of the bridge will be taken into consideration.

### **d. Socio-economic and Cultural Environment**

Demography, caste/ethnicity, literacy, migration trend, resource-income, services/facilities, trade/business, indigenous and vulnerable groups, settlement pattern, Structure and Public utilities, etc. will be collected and documented. Information on socio-economic and cultural features of the project area including population, ethnicity/caste, employment facilities and education, health and sanitation condition will be collected. Similarly, data description of settlement pattern, migration, religion and religious sites, land holding size, crop production and cropping pattern (agriculture), sources of energy and energy consumption, infrastructure and development activities in project area will be collected. Documentation of families to be directly affected by the project will be listed out.

Further, the project affected religious, places of worship/ ritual and cultural sites such as temples, religious and community areas, chautaras, ghumba, grave yards, etc. if any along the road alignment will also be collected and discussed in the IEE Report.

## **3.2 Procedure for data collection**

### **3.2.1 Desk Study**

The reports and documents relevant to project will be collected and studied from various sources to the extent they are available, such as road alignment map, topographical maps,

project feasibility study reports, district profile of Kavrepalanchowk and Sindhuli Districts, prevailing policies, acts, rules, guidelines, manual, review of proposal related published documents.

Initial interaction and consultation will be carried out with the local level and district level stakeholders for collecting the baseline information of the project area. Questionnaires and checklists will be prepared to collect information on physical, chemical, biological, socio-economic and cultural environment of the project area.

The project area will be delineated tentatively on the topography map published by the department of survey and will be verified during field survey through consultation with local people to fix DIA, IIA and ZoI.

The feasibility and detailed design of the bridge section will be reviewed and important data and information will be noted for future use.

#### **3.2.1.1 Checklist/ format/ questionnaire preparation**

A simple and logical checklist format and household questionnaire will be prepared for knowing and updating the existing socio- economic and cultural environment, physical environment and biological environment of the Project Area. The details are provided in the Appendix 1 and Appendix 2

#### **3.2.1.2 Literature Review**

Various information and useful data from reliable sources related with the project study will be collected and reviewed. Such sources of information included existing laws, rules, guidelines and manuals, IEE reports of similar projects, Environment and Social Management framework published by DoR, GESU.

Detailed Engineering Survey and Design Report of the proposed project will be reviewed to determine the nature and scope of activities of the project. Similarly, pertinent sources of secondary information will be identified, collected and reviewed to build acquaintance with the environmental settings of the project area under physical, biological, socio-economic, and cultural domains of the environment.

### **3.2.2 Field Study**

Field study will be conducted in the proposed project area in an extensive manner. The IEE team (Appendix 1-3) will walk through along the road alignment covering the bridges' locations observing the significant environmental features in the probable influence corridor, and make necessary measurements, inspect/observe and discuss it with the local stakeholders. The information collection will be done covering physical, biological, socio-economic and cultural aspects of the environment.

#### **3.2.2.1 Survey**

Survey of DIZ and IIZ (Physical, biological, socio-economic and overall) area will be done during pre-construction phase. The study of the reports and documents relevant to the project will be carried out to collect secondary data on environmental domains namely socio-economic environment and cultural environment, physical environment and biological environment.

#### **3.2.2.2 Focus Group Discussion**

FGDs will be conducted in major settlements within the indirect impact area of project affected municipalities and wards. Local people, political leaders, social workers, teachers,

entrepreneurs, farmers etc. will be included as far as possible in the discussions. List of people participated in the FGD meeting and their responses will be included in the IEE report.

**Household Survey:** Questionnaires will be used to evaluate the socio-economic status of the households located in the project affected area and whose land and property lying within the 500 m aerial distant of the existing road section may be temporarily or permanently affected by the project.

### **3.2.2.3 Walk Through Survey**

Walk through survey of the proposed project area will be done by IEE team based on the questionnaires, checklists prepared during desk study. The proposed project area will be observed and necessary information will be collected on the socio- economic and cultural environment, physical environment, biological environment and chemical environment by interaction with local stakeholders, district level stakeholders and project affected personals.

### **3.2.2.4 Public Consultation**

The role of public consultation and participation is to ensure the quality, comprehensiveness, and effectiveness of IEE report as well as to ensure that the public views are adequately taken into consideration in the decision making process. It will be done during the preparation of the IEE Report. In order to ensure the public involvement, the following procedures will be followed during IEE study and report preparation:

- A public notice of 15 days will be published in a national level daily newspaper seeking written opinion from concerned municipality, DCC, schools, health posts, DFO and related local organizations. A copy of the public notice will be affixed in the above mentioned organizations and deed of enquiry (*muchulka*) will be collected.
- Recommendation letter from concerned DCC, and/or wards of municipality will also be obtained.
- IEE study team will also carry out interaction with local communities and related stakeholders and will also collect the public concerns and suggestions.

### **3.2.3 Data analysis and Interpretation**

Primary and Secondary data will be processed using commonly use methods, available maps will be interpreted. Data on physical, chemical and biological will be tabulated as appropriate. Socio-economic and cultural data will be analyzed and cross checked and tabulated. Standard conversion charts and tables will be followed as and when needed. Wherever possible, chart, diagrams, photographs, maps, matrixes, bar chart and other methods of presentation will be used in order to make the final report more informative and illustrative.

The identification and prediction of impacts will be carried out by considering the proposed project actions/activities in terms of construction and operation stages of the project. The impacts of the activities on biophysical, social, economic, and cultural resources in a defined Zone of Influence (Zol) will be analyzed. The impacts will be classified in terms of extent (site specific, local, and regional), magnitude (low, medium, and high) and duration (short term, medium term and long term) as well as nature (Direct. Indirect), Significance Level (low, moderate, and significant). The likely impact will be assessed covering both adverse and beneficial ones. The methodology adopted for impact identification, prediction and evaluation will be as directed by the National EIA Guidelines, 1993.

### **3.2.4 Report Preparation and presentation**

Based on the analysis of impacts and their nature, appropriate beneficial impacts maximization measures and adverse impacts mitigation measures will be prepared. Such measures will be based on site specific issues, past experience on similar projects, and expert judgments. Monitoring plan for the implementation of mitigation measures will be prepared. Based on the above Environmental Management Plan will be prepared including defined activities, their impacts, mitigation measures, their methodology, implementation schedule, responsible and supervisory agency to implement such measures and cost for mitigation as well as monitoring activities. IEE report will be prepared including all the above said details.

IEE report will be prepared in accordance with the content given in schedule 5 of the EPA/EPR, 1997. The draft report will be prepared and submitted to the Ministry of Physical Infrastructure and Transport (MoPIT) for necessary review, comments and suggestions. A presentation program will be organized in the MoPIT. The comments and suggestions received from the MoPIT will be incorporated and final report will be submitted for approval.

## **4. POLICIES, LAWS, RULES AND MANUALS TO BE TAKEN INTO ACCOUNT WHILE PREPARING THE REPORT**

Government of Nepal has adopted various policies, acts, regulations and guidelines to ensure the integration of development with the environmental conservation. The IEE study will be guided by the requirements and provisions of the relevant policies, acts, regulations and guidelines. They are as presented hereunder:

### **i) Constitution**

Constitution of Nepal

### **ii) Plans and Policies**

- National Forest Policy, 2075 BS (2019 AD)
- 14<sup>th</sup> Plan, 2073 BS (2017 AD)
- Land Acquisition, Resettlement and Rehabilitation Policy for Infrastructure Development Projects, 2071 BS (2014 AD)
- Climate Change Policy, 2011 AD
- ADB Safeguard Policy Statement, 2009
- 20 Year Road Plan, 2059 BS – 2079 BS (2002 AD – 2022 AD)
- National Transport Policy, 2058 BS (2001 AD)
- Policy Document of DoR on Environmental Assessment in the Road Sector of Nepal, 2057 BS (2000 AD)
- Nepal Environmental Policy and Action Plan, 2049 BS (1993 AD)
- DoR Bridge Policy and Strategy, 2061 BS (2004)

### **iii) Acts and Rules**

- Environment Protection Act, 2076 BS (2019 AD) and Environment Protection Rules, 2054 BS (1997 AD)
- Local Body Government Act, 2074 (2017 AD)
- Public Road Act, 2031 BS (1974 AD)

- Forest Act, 2076 BS (2019 AD) and its Rules, 2051 BS (1995 AD, Amended in 2005)
- Land Acquisition Act, 2034 BS (1977 AD) and Land Acquisition Regulation, 1969 AD
- Soil and Watershed Conservation Act, 2039 BS (1982 AD)
- Local Government Operation Act, 2074 BS (2017 AD)
- Labor Act, 2074 BS (2017 AD) and Labor Rules, 2075 BS (2018 AD) with amendments
- Child-Related Act, 2050 BS (1993 AD) and Child Labor Act, 2058 BS (2001 AD)
- The Convention on International Trade in Endangered Species of Wild Fauna and Flora (CITES) Act, 2074 BS (Amended 2075 BS)
- Solid Waste Management Act, 2068 BS (2011 AD)
- Solid Waste Management Regulation, 2070 BS (2013 AD)
- Motor Vehicle and Transportation Management Act, 2049 BS (1992 AD) and Rules, 2054 BS (1997 AD)
- Road Board Act, 2058 BS (2002 AD)
- Aquatic Animal Protection Act, 2028 BS (1961 AD)
- Water Resources Act, 2049 BS (1992 AD)

#### **iv) Manuals/Guidelines/Directives**

- Environmental Management Guidelines, GESU/ DoR, 2054 BS (1997 AD)
- National Environmental Impact Assessment Guidelines, 2050 BS (1993 AD)
- Roadside Bio-Engineering- Site Hand Book, DoR, GoN, 2056 BS (1999 AD)
- Manual for Environmental and Social Aspect of Integrated Road Development, 2003 AD
- Guide to Road Slope Protection Work, 2003 AD
- Statistics to Strategic Road Network (SSRN), 2011 / 2012
- Guidelines for Environmental Management in Road Sector, 1999 AD
- Government Tree Removing Standards (2017 AD)
- Environmental and Social Management Framework (ESMF), 2064 BS (2007) with Addendum 2013 (Revised)
- Bridge Inspection Manual, 2061 BS (2005 AD)
- Guidelines for inspection and maintenance of bridges
- Bridge Maintenance Manual, 2061 BS (2005 AD)
- Gender Equality & Social Inclusion Operational Guideline-MoPIT, 2017AD

#### **v) Environmental Standards**

- Nepal Bridge Standards, 2067 (2010 AD)

- National Ambient Air Quality Standard, 2069 BS (2012 AD)
- National Standard About Noise Level, 2069 BS (2012 AD)
- Nepal Vehicle Mass Emission Standard, 2069 BS (2012 AD)
- National Diesel Generator Emission Standard, 2069 BS (2012 AD)

**vi) Conventions**

- Convention on Biological Diversity, 2049 BS (1992 AD)
- The Convention on International Trade in Endangered Species of Wild Fauna and Flora, (CITES), (Signed at Washington, D.C., on 3 March 1973, Amended 1979, 1983, 2017)
- ILO Convention on Indigenous and Tribal Peoples, 1989 AD (No. 169)
- United Nations Framework Convention on Climate Change (UNFCCC), 1992 AD

## 5. PREPARATION OF THE REPORT

In general, the time-frame for IEE Study is four (4) months after the approval of Terms of Reference and a tentative schedule is given in Table 5.1.

**Table 5- 1: Proposed Work Schedule**

Activities No.	Items	December 2019				January 2020				February 2020				March 2020				April 2020				May 2020			
		1	2	3	4	1	2	3	4	1	2	3	4	1	2	3	4	1	2	3	4	1	2	3	4
		1	DESK STUDY / MOBILISATION AND START UP ACTIVITIES																						
2	PREPARATION and SUBMISSION OF TOR DOCUMENT, DATA MANAGEMENT																								
3	TOR DOCUMENT APPROVAL (Assumption)																								
4	PREPARATION and SUBMISSION OF IEE DRAFT REPORT																								
5	PRESENTATION ON IEE DRAFT REPORT																								
6	RECEIVING COMMENTS and SUGGESTION FROM VARIOUS EXPERTS (Assumption)																								
7	COMMENTS INCORPORATION AND SUBMISSION OF THE FINAL IEE REPORT																								
8	IEE Final Approval from MOPIT (Expected)																								
9	TOR Submission in 3 weeks after signing the contract								▲																
10	Draft IEE Report in 6 weeks after receiving the approval letter from Proponent.															▲									
11	Final IEE Report in 4 weeks after receiving the comments																							▲	
12	IEE Final Approval from MOPIT (Expected in 2 weeks after submission of the IEE)																								▲

▲ Denotes the date of Reports submission

### Estimated Budget

The budget for the IEE study is a part of consulting services is NRs 500,000.00 including VAT.

### Necessary Experts

Necessary experts involved in the preparation of the IEE study for this proposed project are

- Environmental experts/ Team Leader
- Road Engineer/Transport/Bridge Engineer
- Geologist
- Socio- Economist
- Hydrologist

Besides the abovementioned experts, adequate number of field assistants will be mobilized to collect field level data, verify secondary information to include in the IEE report.

## **6. (DELETED BY FIRST AMENDMENT, GoN, 1999)**

## **7. SPECIFIC IMPACTS/ ISSUES OF THE PROPOSAL ON THE ENVIRONMENT**

The GEC (P) Ltd on behalf of the Proponent will identify likely impacts (beneficial as well as adverse) on the physical, biological, chemical, socio-economic and cultural environment by the project during its pre- construction, construction and operation phases of the project. The GEC (P) Ltd on behalf of the Proponent will categorize those impacts in terms of nature, magnitude, extent and duration for the enhancement of beneficial impacts and mitigation measures for the remedial or reduction of the adverse impact on the environment.

### **7.1 Beneficial Impacts**

- Enhancement of local skills in bridge construction
- Enterprise Development and Commercialization
- Enhancement in Technical Skills and know-how
- Easement of former Environmental problems
- Exploitation of untapped potentials

### **7.2 Adverse Impacts**

#### **7.2.1 Socio-Economic environment**

##### **i. Pre-Construction phase**

- Loss of production (crops, Trees-private)
- Land and property acquisition (private)
- Acquisition of public/community land

##### **ii. Construction phase**

- Loss of private and community structures
- Impact of human health
- Occupational Safety and Health Issues
- Damage of Community infrastructures
- Conflict in or with nearby host communities between local and outsiders

##### **iii. Operation and maintenance phase**

- Population pressure and impact due to new settlement along the road alignment
- Impacts of increased Road Traffic
- Road and bridge safety

#### **7.2.2 Culture Environment**

##### **i. Construction Phase**

- Impact on Religious, Cultural and Historical Assets
- Impact on Archeological site

#### **7.2.3 Physical Environment**

##### **i. Pre- Construction Phases**

- Permission for concern authorities/ parties/persons for quarry and borrow pit crusher plant operation, Labor camps, stockpiling spoil disposal site, use of water source
- Relocation of community utilities
- Others (Relevant)

ii. Construction Phase

- Landslide, slope destabilization and soil erosion
- Establishment and operation of Work camp, Labor camp, stockpiling Yard, crusher plant
- Hazards due to spoil disposal
- Water flow diversion (Obstruction to natural drainage pattern)
- Vibration due to heavy equipment
- Water regime change
- Potential impacts caused by Bitumen
- Air, water and Noise Pollution

iii. Operation and Maintenance phase

- Damage to bridge section during Defect Liability Period (DLP)
- Obstruction on drainage
- Cleaning of Work camp, Labor camp, stockpiling Yard

#### **7.2.4 Biological Environment**

i. Pre-Construction Phase Issues

- Vegetation Clearance
- Permission for clearance of forest area/ tree

ii. Construction Phase

- Clearance of road side tree
- Effect on aquatic life and River regime (morphology, profile. etc)
- Others (if any)

#### **7.2.5 Chemical Environment**

i. Pre-Construction Phase

- Use and storage of fuel, lubricants, oils, acids, and other chemicals for construction

ii. Construction Phase

- Hazard caused by chemical materials/fuel, chemical
- Hazard caused by Storage, handling, heating and spreading bitumen (Asphalt, Concrete and Hot mix plant)

### **7.3 Other likely Issues Encountered/ Raised by Public during IEE Study**

Apart from the above mentioned impacts/issues, any new issues encountered during the study period will be included and analyzed during the report preparation.

## **8. ALTERNATIVES FOR THE IMPLEMENTATION OF THE PROPOSAL**

The following alternatives will be studied during the IEE report preparation to recommend environmentally sound proposal. Likely beneficial and adverse impacts for each alternative proposal will be studied in detail and recommend the project that has not much severe impact on the physical, biological, socio-economic and cultural environment.

- No action option
- Project alternatives
- Alternative alignment (Bridge)
- Alternative design and construction approach
- Alternative schedule and process
- Alternative resources

Likely impacts of each alternative will be assessed and compared in terms of adverse environmental impacts and benefits, and the environmentally sound alternative will be recommended.

## **9. MATTERS CONCERNING THE PREVENTION OF THE IMPACT OF THE IMPLEMENTATION OF THE PROPOSAL ON THE ENVIRONMENT (MITIGATION MEASURES)**

Mitigation measures for all the identified significant impacts will be taken into consideration during preparation of the IEE report. The GEC (P) Ltd on behalf of the proponent will propose mitigation measures to prevent or reduce significant adverse impacts to acceptable levels. Measures to enhance beneficial project impacts will also be presented. The mitigation measures will be proposed for physical, biological, socio-economic and cultural environments for construction and operation phases.

5Ws principle will be adopted while developing mitigation measures, which include the followings:

- WHAT mitigation measures?
- WHO will implement the mitigation measures?
- WHEN will the mitigation measures be implemented?
- WHERE will the mitigation measures be implemented?
- WHAT standards/requirements for mitigation measures?

The mitigation measures will be site specific and developed by applying a pragmatic approach that is technically and economically feasible, socially acceptable, and preferably, of proven effectiveness. The cost required for each and every mitigation measure and enhancement measures will be identified in detail and incorporated in IEE report. Cost of mitigation and enhancement measures will be categorized in terms of pre-construction, construction and operation phases.

The enhancement and mitigation measures will be categorized in terms of the physical, biological, socio-economic and cultural environment for the construction and operation

phases. A matrix of impact and mitigation measures will also be included in the IEE report in the format as presented below.

**Table 9-1: Beneficial Impacts, Augmentation and enhancement measures**

Activities/Issue	Impact	Augmentation and Enhancement Measures	Cost	Responsible Agency
<i>Construction Phase</i>				
<i>Operation and Maintenance Phase</i>				

**Table 9-2: Adverse Impacts and Mitigation measures**

Activities/Issue	Location	Impact	Mitigation Measures	Cost	Responsible Agency
<i>Pre-construction Phase (all domains)</i>					
<i>Construction Phase (all domains)</i>					
<i>Operation &amp; Maintenance Phase(all domains)</i>					

**Table 9-3: Summary of Enhancement and Mitigation measures Cost**

S. No.	Description	Cost	Remarks

The IEE will propose organizations and agencies to be consulted while implementing mitigation programs.

#### **10. MATTERS TO BE MONITORED WHILE IMPLEMENTATION OF THE PROPOSAL (ENVIRONMENTAL MONITORING PLAN)**

To monitor the impacts of the proposed project on physical, biological, socio-economic and cultural resources of the area, an environmental monitoring plan will be formulated. The proponent will be responsible for the implementation of environmental monitoring of the proposed project.

5Ws principle will be adopted while developing mitigation measures, which include the followings:

- WHAT will be monitored?
- WHO will implement the monitoring program?
- WHEN will the monitoring be implemented?
- WHERE will the monitoring be implemented?
- WHAT standards/requirements for monitoring?

The monitoring plan will include the following aspects;

- Baseline, compliance and impact monitoring in terms of the physical, biological, Socio-economic and cultural environment. Baseline and impact monitoring will include parameters, indicators, methods, schedules and locations, while compliance monitoring will include parameters, indicators, methods and schedules. Compliance and impact monitoring will be categorized in terms of construction and operation phases;
- Agency responsible for monitoring and agencies to be consulted, if required, during monitoring activities, and
- Organizational set-up, budget and human resources requirements for carrying out the environmental monitoring.

A matrix of monitoring plan will also be included in the IEE report in the format as presented below.

**Table 10-1: Monitoring Plan**

Parameter/Impact	Verifiable Indicators	Verification Methods	Implementing Agency	Monitoring Agency	Cost
<b>Baseline/Pre-construction phase (all domain)</b>					
<b>Compliance/Construction phase (all domain)</b>					
<b>Impact/Operation &amp; Maintenance Phase (all domain)</b>					

## 11. OTHER NECESSARY MATTERS

The other necessary matters to be included in the IEE Report will be the relevant information, reference list, annexes, maps, photographs, tables and charts, and survey questionnaires used at the time of carrying out baseline survey. Also included will be the details of public consultation, public notice, *muchulka* (Deed of enquiry) of pasting public notice, recommendation letters from concerned municipality etc. The Report Format for IEE Study will follow Schedule 5 of EPR. All requirements indicated in Schedule 5 of the EPR will be included and addressed in the IEE report. The conclusions and the recommendations of the Study will be drawn and presented at the end of the report.

## 12. IEE REPORT FORMAT

IEE report will be in the format of the schedule 5 of EPR, 1997 and template for IEE report for Road/ bridges, MoPIT, 2017 prepared by GESU and details will be project specific.

## 13. REFERENCES

- DoR, GESU, 1999, Environmental Management Guidelines, Department of Roads, Ministry of Physical Planning and Works, Kathmandu.
- DoR, 2013, Nepal Road Standard 2070, Department of Roads, Ministry of Physical Infrastructure and Transport, Kathmandu.
- HMGN, 2000, Environment Protection Act, 2076 (2019 AD) and Environment Protection Rules, 2054 (1997 AD).
- Ministry of Law, Justice and Parliamentary Affairs, Law Books Management Board, Kathmandu.
- Nepal Population and Housing Census, 2011.

- Government of Nepal, Environment Protection Act, 1996
- Government of Nepal, Environment Protection Rule, 1997 (first amendment, 1999)
- Department of Roads, MPPW, GON, Kathmandu, Reference Manual for Environmental and Social Aspects of Integrated Road Development, 2003

# **APPENDICES**

## Appendix 1-1: Checklist for field survey

### (i) Land use Pattern (Bridge Approach)

S. No.	Land Use Type	Area (ha)		Remarks
		Right Bank	Left Bank	
1.	Permanent (Built-up)			
2.	Temporary			
3.	Agricultural land			
4.	Pasture/Grass land			
5.	Forest/Jungle land			
6.	Others			

### (ii) Baseline Information

S. No.	Bridge Chainage	Length	Elevation (m)	Geology	Geomorphology

### (iii) Plant Resources

S. No.	Name of Plants	Uses			Others
		Fuel wood	Fodder	Medicine	

### (iv) Wildlife Animals

S. No.	Wild Animals	Remark

Note:

---



---



---

(v) Information on the Vegetation

S. No.	Name of Bridge	Land Ownership Type	Number of Trees		Remarks
			Right Bank	Left Bank	

(vi) Aquatic Animals

S. No.	Aquatic Animals	Remark

Note:

---

---

---

(vii) Information on Quarry Sites

Description	Distance to the quarry site	Type of material available	Status of Access Road (Metalled/Gravel/Earthen)	Approx. Quantity of material available	Equipment used for materials Extraction	Remarks

(viii) Information on Stockpile Sites

S. No.	Chainage/Location	Type of material	Status of Access Road	Approx. Quantity of material

(ix) Information on Camp Sites

S. No.	Chainage/Location	Municipality/VDC	Land Type	Remarks

## Appendix 1-2: Household Questionnaires

पुलको नाम:

क्र.सं. ....

सडक विभाग

सामाजिक-आर्थिक आधाररेखा अध्ययन

आधारभूत घरधुरी सर्भेक्षण प्रश्नावली

अन्तरवार्ता लिनेको नाम : .....

अन्तरवार्ता मिति: .....

अन्तरवार्ता सुपरीवेक्षक : .....

अन्तरवार्ता पुनरावलोकन मिति: .....

### १. सामान्य जानकारी

१.१ जिल्ला .....

१.२ हालको गाउँपालिका / नगरपालिका.....

१.३ वडा नं. ....

१.४ गाउँ/टोल/वस्तीको नाम: .....

१.५ घरमुलीको नाम, थर .....

१.५.१ जाती ..... १.५.२ उमेर ..... १.५.३ लिंग ..... १.५.४ परिवारमा बोल्ने भाषा: .....

१.५.६ समुदायमा बोल्ने भाषा.....

१.६ उत्तरदाताको जानकारी १.६.१ नाम थर ..... १.६.१ उमेर ..... १.६.२ लिंग .....

१.६.३ घरमूलीसंग नाता..... सम्पर्क नं. ....

### २.० पुलको दायाँबायाँ अवस्थित घर नक्सांकन

चेनेज नं.....



३.०. जनसंख्यिक तथा सामाजिक आर्थिक विवरण

३.१. परिवारको जोखिमता

३.१.१ महिला घरमुली (विधुवा वा एकल महिला) ३.१.२ महिला घरमुली(कामको लागि पुरुष बसाँई सरेको)

३.१.३ शारीरिक असक्तता भएको व्यक्ति घरमुली ३.१.४ कमाउन नसक्ने जेष्ठ नागरिक घरमुली

३.२. पारिवारीक विवरण र आय (घरमूली सहित)

क्र सं	घरमुली संगको नाता	लिंग	उमेर	वैवाहिक स्थिती	शिक्षा	पेशा व्यवसाय	मासिक आय	वार्षिक आय
१								
२								
३								
४								
५								
६								
७								
८								
९								
१०								
११								
१२								
१३								
१४								
१५								

संकेत:

- १) घरमुली संगको नाता: घरमुली १, श्रीमती २, श्रीमान ३, छोरा ४, छोरी ५, भाई ६, बहिनी ७, नाती ८, नातिनी ९, बुहारी १०, भाई बुहारी ११, आमा १२, बुवा १३, बाजे १४, काका १५, काकी,
- २) लिङ्ग : पुरुष-१, महिला-२, तेस्रो लिङ्ग-३
- ३) वैवाहिक अवस्था : विवाहित-१,अविवाहित-२, पारपाचुके-३, विधुवा/विदुर-४

- ४) शिक्षा : निरक्षर-१, साक्षर-२, प्राथमिक-३, कक्षा (५-१०) - ४, कक्षा (१०-१२) - ५, स्नातक वा माथि - ६, विद्यालय छाडेको - ७,
- ५) पेशाव्यवसाय: कृषि आफ्नै - १, कृषि अधिया - २, पशुपालन -३, नोकरी -४, व्यापार -५, उद्योग व्यवसाय -६, कृषि मजदुर -७, गैर कृषि मजदुर-८, विद्यार्थी-९, वैदेशिक रोजगार-१०, गृहिणी-११, केहि पनि नगर्ने-१२, अन्य (खुलाउने .....
- ३.३. परीवारको एक वा वढी सदस्य वैदेशिक रोजगारमा गएको भएमा वसाई अवधि  
महिला: पुरुष:
- ३.४ वसाई सराई स्थिती
- ३.४.१ के तपाईंको परीवार यस क्षेत्रमा वसाई सरि आउनु भएको हो ? १. हो २. होईन
- ३.४.२ हो भने

वसाई सरिआएको ठाँउ	वसाई सरेको वर्ष	कारण	स्थायी/अस्थायी	उद्देश्य	कैफियत

संकेत:

१)वसाई सरिआएको ठाउँ : आफ्नै गा. पा-१,आफ्नै जिल्ला-२, जिल्ला बाहिर-३, अन्य-४

२) कारण : सडक सुविधा १, अन्य उल्लेख गर्ने २

३) स्थायी/अस्थायी : स्थायी-१, अस्थायी-२

४) उद्देश्य : रोजगारी-१, व्यापार व्यावसाय-२, शिक्षा-३, अन्य-४

३.५. परीवारको स्वामित्वको जग्गाको किसिम र लैंगिक स्वामित्व

विवरण	जम्मा	जग्गा धनी		घर वारी (रोपनी)	खेती गर्ने जग्गा (रोपनी)	पाखो वारी (रोपनी)	खरवारी (रोपनी)	अन्य
		महिला	पुरुष					
कित्ता संख्या								
क्षेत्रफल								

३.६. तपाइको आफ्नो खेतवारीबाट उत्पादनभएको अन्नपातले कति महिना खान पुग्छ?

१ (०- ३),

२ (३- ६)

३ (६- ९)

४ (९- १२)

३.७. जग्गाको उपयोग स्थिती

क्र स	जग्गाको प्रकार	कित्ता संख्या	जम्मा क्षेत्रफल (रोपनी)	आफ्नै प्रयोजन क्षेत्रफल(रोपनी)	भाडामा दिएको क्षेत्रफल		भाडामा लिएको क्षेत्रफल	
					(रोपनी)	मासिक भाडा	(रोपनी)	मासिक भाडा
१	जम्मा जग्गा							
२	घरेलु जग्गा							

३	व्यवसायिक र व्यापारीक जग्गा							
४	निजी वन रुख विरुवाको जग्गा							
५	फलफूल खेती गरीएको जग्गा							
६	तरकारी वाली लगाएको जग्गा							
७	नगदे वाली लगाएको जग्गा							
८	अन्नवाली, दाल वाली, तेल वाली लगाएको जग्गा							
९	वांभो जमिन							
१०	सिचाई व्यवस्था भएको जग्गा							

३.८. निजीवन रुख विरुवा उपयोग स्थिती

क्र स	जग्गाको प्रकार	रुखविरुवा संख्या	उत्पादनको किसिम	प्रति रुख विरुवा उत्पादन (साला खाला)	
				उत्पादन मुल्य	विक्री मुल्य
१	निजी वन रुखविरुवा				

३.९. फलफूलको रुखविरुवा उपयोग स्थिती

क्र स	फलफूलको किसिम	रुखविरुवा संख्या		गत वर्षको उत्पादन परिमाण (केजी)	उत्पादन मुल्य	विक्री मुल्य
		फल लाग्ने	सानो			
१						
२						
३						
४						

३.९.१. यदि खान नपुग भएको महिनामा खाधान्न र अन्य खरिद गरेर खानपर्दा महिनामा कति खर्च लाग्छ?

रु.....

३.९.२. खान नपुग्ने महिना वर्षको खाद्यान्न व्यवस्था गर्न गतवर्ष निम्न कुनै स्थिती व्यहोर्नु पर्यो?

१ - होइन २- हो हो भने किन?

क्र.सं.	ऋण/सापट	जग्गा विक्री	पशु विक्री	अन्य (खुलाउने)
कोड				
कारण				

३.९.३. अन्य कुनै कार्य र उद्देश्यका लागि ऋण लिनु भएको छ ? १- छ २-छैन

छ भने कहाँबाट? कति ब्याजदरमा?

क्र.सं.	वित्तीय संस्था	रकम(रु.)	ब्याजदर	उद्देश्य
१	बैंक			
२	साभ्का सहकारी			
३	साहु महाजन			
४	नातेदार/साथी			
५	बचत समूह			

उद्देश्य सङ्केत: १-घर जग्गा किन्न, २-व्यापार/व्यावसाय, ३-घरखर्च, ४- विवाह, ५-कृषिकार्य, ६-स्वस्थ्यउपचार, ७-विदेशजाने, अन्य .....

३.९.४. गतवर्ष तपाईंले निम्न शीर्षकमा कति खर्च गर्नुभयो ?

क्र.सं.	खर्चको विवरण	रकम रु.	कैफियत
१	खाद्यान्न (अन्नपात)		
२	फलफूलतथा तरकारी		
३	नुन, तेल, मसलाआदि		
४	लुगाफाटा		
५	शिक्षा		
६	स्वास्थ्यउपचार		
७	दाउरा मट्टितेल, ग्यास		
८	पानी, विजुली		
९	कृषि सामग्री (मल, विउ, औजार)		
१०	दाना (पराल, मकै, घाँस)		

क्र.स.	खर्चको विवरण	रकम रु.	कैफियत
११	ऋणको व्याज तिर्न		
१२	यातायातर संचार		
१३	धार्मिक कार्य/ चाडवाड मान्न		
१४	गहना किन्न		
१५	मनोरञ्जन		
१६	सामाजिक कार्यको लागि चन्दा		
१७	चिया सुर्तिजन्य तथा मादक पदार्थ		
१८	माछामासु		
१९	अन्य (खुलाउने) .....		
जम्मा			

#### ४.०. स्वास्थ्य तथा एचआईभी संक्रमण स्थिती र सेवाहरु

४.१. गत वर्ष तपाईं वा तपाईंको परिवारको सदस्य विरामी भएको थियो ?

१.थियो २. थिएन

४.२ यदि थियो भने के कस्तो रोग लाग्यो उल्लेख गर्नुहोस ?

क्र.स.	रोगहरु	प्रभावित सदस्य संख्या		
		महिला	पुरुष	कैफियत
१	भाडापखाला			
२	टाईफाइड			
३	मलेरिया			
४	जण्डिस			
५	प्रशुति सम्बन्धी			
६	आइखस्ने (पाठेघर)			
७	छाला सम्बन्धी			
८	ग्यासट्रिक			
९	दम			

क्र.स.	रोगहरु	प्रभावित सदस्य संख्या		
१०	आँखा सम्बन्धी			
११	हैजा			
१२	एच.आई.भि.			
१३	अन्य.....			

४.३ उपचार गर्न पहिला र पछि कहाँ कहाँ जानु भयो विवरण भन्नुहोस? प्राथमिकताका आधारमा उल्लेख गर्नुहोस।

क्र.स.	स्वास्थ्य संस्था	कती पटक		घरबाट दुरी	ज्ञातायात माध्यम	पुग्न लाग्ने समय
		महिला	पुरुष			
१	जिल्ला अस्पताल					
२	प्राथमिक स्वास्थ्य केन्द्र					
३	स्वास्थ्य/उप स्वास्थ्य चौकी					
४	प्राइभेट क्लिनिक					
५	नर्सिङ होम					
६	धामिभाँकी					
७	अन्य .....					

४.४ तपाईले एच.आई.भि./एड्स र सो सने माध्यमहरुवारे जानकारी छ भने कहाँबाट जानकारी पाउनु भयो ?

१. छिमेकीले भनेर २. रेडियो/टि.भी. ३. पत्रपत्रिका ४. सामाजिक कार्यकर्ता ५. अन्य .....

४.५. तपाईले पाएको जानकारी अनुसार सने माध्यमहरु कुनकुन रहेको छ ?

१.

२.

३.

४.

४.६. तपाईको समुदायवा वरीपरी कसैलाई एचआईभि लागेको वारे जानकारी छ भने निम्न जानकारी दिनु होस

१. छ

२. छैन

क्रसं	संकमित रहेको स्थान	सडकवाट दुरी	संकमित संख्या

४.७. तपाईंको समुदाय वा वरीपरी एचआईभी वारे संचालित कार्यक्रम तथा क्षेत्रहरु वारेमा बताउनु होस् ।

४.८. कार्यक्रम गर्ने संस्थाहरुवारे थाहा छ भने नाम, ठेगाना र सम्पर्क ब्यक्ति तथा नम्बर बताउनु होस् ।

४.९. एच.आइ.भी. एड्स रोकथाम गर्न यस क्षेत्रमा जनचेतना कार्यक्रम आवश्यक छ ?

१ छ

२ छैन

छैन भने किन.....

छ भने के कस्ता कार्यक्रम संचालन गर्नु उपर्युक्त होला?

४.९.१ विगत पाँच वर्षमा तपाईंको परिवारका कुनै सदस्यहरुको मृत्यु भयको थियो ?

१.थियो

२. थिएन

थियो भने निम्नजानकारी दिनु होस्?

क्र.सं.	लिङ्ग	मृत्यु हुँदाको उमेर	मृत्यु हुनाको कारण	मृत्यु भएको साल	कैफियत

लिङ्ग संकेत :१- पुरुष, २-महिला

५.०. मानव बेचबिखन

५.१. यस ठाउँ वा वरीपरी वस्तीहरुमा मानव बेचबिखन घटना भएकोवारे जानकारी छ ?

१- छ २- छैन

५.२. छ भने निम्न जानकारी दिनु होस

क्र.सं	घटना भएको स्थान	सडकवाट दुरी	घटना संख्या

५.३ यस ठाउँ र वरीपरी मानव बेचबिखन सम्बन्धी कार्यक्रम भएकोवारे थाहा छ?

१ छ २ छैन

थाहा छ भने कार्यक्रम गर्ने संस्थाको नाम, ठेगाना र सर्म्पक व्यक्ति तथा नम्बर वताई दिनुहोस् ।

.....

.....

#### ६.०. सामाजिक लैंगिक सहभागिता स्थिती

६.१. के तपाईं वा तपाईंको परिवारका सदस्यहरु सामाजिक संस्थाको सदस्य हुनुहुन्छ ?

१. छ २. छैन

छ भने निम्न जानकारी दिनु होस्:

क्र.स.	विवरण	साधारण सदस्य संख्या		कार्यकारी सदस्य संख्या		कैफियत
		पुरुष	महिला	पुरुष	महिला	
१	कृषक समूह					
२	सहकारी संस्था					
३	वन उपभोक्ता समूह					
४	आमा समूह/महिला समूह					
५	खानेपानी उपभोक्ता समूह					
६	सिंचाई/कुलो समूह					
७	आयआर्जन समूह					
८	गैर सरकारी संस्था					
९	युवाक्लव					
	अन्य .....					
	अन्य .....					

६.२. पुल निर्माणवाट हुने प्रभाववाट लाभान्वित हुन महिला र पुरुष लक्षित के कस्ता सिपविकास तालिमको

आवश्यकता महशुस गर्नु भएको छ ?

लक्षित समुह	सिपविकास तालिमको नाम	तालिमको उपयोगको सम्भावना
महिला		
पुरुष		

६.३. नोकरी, रोजगारी, व्यापार, व्यवसाय, शिक्षाको लागि घरबाट यातायात साधन प्रयोग गरी वा नगरी नियमित यात्रा गर्नु पर्ने परीवारका सदस्यहरूको विवरण

लिङ्ग	१ घरमुली संग नाता	२ नियमित यात्रा गर्नु पर्ने कारण	स्थान	दुरी (किमी)	३ यात्रा साधन	जान आउन लाग्ने समय	जान आउन लाग्ने खर्च	हप्तामा कती पटक यात्रा
महिला								
पुरुष								

संकेत:

१) घरमुलीसंगको नाता: १-घरमुली , २-श्रीमती, ३-श्रीमान, ४-छोरा, ५-छोरी, ६-भाइ, ७-बहिनी, ८-नाती, ९-नातिनी, १०-बुहारी, ११-भाई बुहारी, १२-आमा, १३-बुवा, १४-बाजे, १५-काका, १६-काकी,

२) लिङ्ग : पुरुष-१, महिला-२, तेस्रो लिङ्ग-३

३) यात्रा गर्नु पर्ने कारण: नोकरी १, व्यापार २, ज्यालादारी काम ३, शिक्षा ४, अन्य (उल्लेख गर्ने)

४) यात्रा साधन: सार्वजनिक यातायात १, निजी गाडी २, निजी मोटर साईकल ३, साईकल ४, हिंडाई ५, अन्य .....

६.४. अहिले प्रयोग गर्ने गरेको सार्वजनिक यातायात साधनको किसिम र महिलाले भोग्नु परेको समस्या:

क्र.सं	सार्वजनिक यातायातको किसिम	महिलाले भोग्नु परेको समस्या
१	बस	
२	मिनी बस	
३	माईको बस	
४	जीप	
५	अन्य ....	

६.५. महिलाले एकलै सुरक्षित यात्रा गर्ने वातावरणको लागी सुधारनु पर्ने कुराहरु सुविधाहरु, व्यवस्थाहरुवारे सुभावहरु: .....

६.६. उही स्तरको काममा महिला र पुरुषको ज्याला कती दिने र लिने गरेको छ ?

क्र.सं	लिङ्ग	कुषि ज्याला	निर्माण व्यवसाय ज्याला	भरीया	अन्य उल्लेख गर्ने
१	महिला				
२	पुरुष				

६.७. लैङ्गिक कार्य साभेदारी

६.७.१ कृषि सम्बन्धि कृषाकलापमा पुरुष र महिलाबीच कार्य विभाजन

क्र.सं.	गतिविधि	पुरुष (संकेत)	महिला(संकेत)
१	जग्गा तयारी (जोत्ने, खन्ने)		
२	मल वोक्ने		
३	विउँ छर्ने		
४	रोप्ने/गोड्ने		
५	सिँचाई गर्ने		
६	बाली काट्ने		
७	बाली वोक्ने/ढुवानी गर्ने		

क्र.स.	गतिविधि	पुरुष (संकेत)	महिला(संकेत)
८	सफा गर्ने/केलाउने		
९	भण्डारन गर्ने		
१०	बजारमा लाने		

संकेत : धेरै-१,कम-२, बराबर-३, गर्दै नगर्ने-४

६.७.२ घरायसी कामहरुमा पुरुष र महिलाबीच सहभागिता

क्र.स.	घरायसीकामकाज	पुरुष (संकेत)	महिला(संकेत)
१	पानी ल्याउने		
२	दाउरा/घाँस ल्याउने		
३	अन्न पिन्ने		
४	कपडा धुने		
५	खाना पकाउने		
६	बालबच्चाको हेरचाह		
७	बुढाबुढीको हेरचाह		
८	सामान खरिद		
९	पशुपंक्षी हेरचाह		

संकेत : धेरै-१,कम-२, बराबर-३, गर्दै नगर्ने-४

६.७.३ तलका कामहरुमा कसले निर्णय गर्छ ?

क्र.स.	क्रियाकलाप	पुरुष (संकेत)	महिला(संकेत)
१	कृषि सम्बन्धि क्रियाकलाप		
२	कृषिउपज खरिद/बिक्री गर्ने		
३	घर जग्गा खरिद/बिक्री गर्ने		
४	ऋण लिने		
५	केटाकेटी पढाउन		
६	धार्मिक कार्य		
७	परिवार नियोजन		

क्र.स.	क्रियाकलाप	पुरुष (संकेत)	महिला(संकेत)
८	सामुदायिक कार्य		

संकेत : धेरै-१,कम-२, बराबर-३, गर्दै नगर्ने-४

६.७.४ सम्पत्तीको स्वामित्व

क्र.स.	सम्पत्तीको स्वामित्व	पुरुष (संकेत)	महिला(संकेत)
१	जग्गा जमिन		
२	घर		
३	नाद		
४	पशुपंक्षी		
५	बैंकमा राखेको रकम		
६	गरगहना		

संकेत: धेरै-१,कम-२, बराबर-३ स्वामित्व नभएको-४

६.८. आधारभूत संरचना

६.८.१ तपाईंको घरमा चर्पिको सुविधा छ ?

१. छ २. छैन

६.८.२ छ भने कस्तो खालको चर्पि छ?

क्र.स.	चर्पिको प्रकार	कैफियत
१	खाल्डे	
२	दुई खाल्डे सुलभ चर्पी	
३	सेप्टिक टैंक भएको आधुनिक फ्लस चर्पी	
४	ढल निकास भएको आधुनिक फ्लस चर्पी	
५	अन्य (उल्लेख गर्ने)	

६.८.३ घरको र चर्पीको फोहर पानीको निकास

१. एउटै २. छुटाछुटै

६.८.४ एउटै भए निकास व्यवस्था के छ?

१.सेप्टिक टैंक २. सार्वजनिक ढल ३. वायो ग्यास ४. खेत वारी ५.अन्य.....

६.८.५ घरबाट निस्कने फोहर के गर्नु हुन्छ ?

१.नगरपालिका संकलन २. कम्पोस्ट मल बनाउने ३. पुन प्रयोग गर्ने ४. वायो ग्यास ५. खेत वारीमा फाल्ने ६ जलाउने ७. सडक छेउछाउ फाल्ने ८ अन्य.....

६.९ खानेपानी कहाँबाट ल्याउनु हुन्छ ? (प्राथमिकता अनुसार लेख्ने १, २, ३.....)

क्र.सं.	श्रोतहरू	प्राथमिकता	कैफियत
१	पाइपधारा		
२	प्राकृतिक कुवा/ढुङ्गेधारा		
३	नदि/खोला/खोल्सा		
४	जमिन मुनिको पानी (ट्युबवेल, पम्प)		
५	आकासे पानी		

६.१० स्रोतबाट ल्याएको पानी कसरी खाने गर्नु भएको छ ?

१ उमालेर २ फिल्टर ३ उमालेर र फिल्टर ४ पियुष प्रयोग ५ अन्य )उल्लेख गर्ने)

७.० खाना पकाउन के प्रयोग गर्नुहुन्छ ? (प्राथमिकता अनुसार लेख्ने १, २, ३.....)

क्र.सं.	श्रोतहरू	प्राथमिकता	कैफियत
१	दाउरा		
२	गोबर ग्यास		
३	एल.पी. ग्यास (सिलिन्डर)		
४	गुईठा/घाँसबाट उत्पादित		

८.० बत्ति वालको लागि के प्रयोग गर्नुहुन्छ ? (प्राथमिकता अनुसार लेख्नुहोस् १, २, ३ .....) )

क्र.सं.	श्रोतहरू	प्राथमिकता	कैफियत
१	मट्टितेल		
२	विजली		
३	सोलार		
४	टकिमारा		
५	अन्य .....		

९.० निम्न सेवा सुविधामा पहुँच सम्बन्धी विवरण

क्र.सं.	सुविधाको अवस्था	जन आउन लाग्ने समय (मिनेट)	साधन
१	प्राथमिक विद्यालय		
२	निम्न-माध्यमिक विद्यालय		
३	माध्यमिक विद्यालय		
४	कलेज/क्याम्पस		
५	अस्पताल		
६	स्वास्थ्य/उप-स्वास्थ्य चौकी		
७	प्राथमिक स्वास्थ्य केन्द्र		
८	स्थानीय बजार		
९	मूख्य बजार		
१०	जिल्ला सदरमुकाम		

१. साधन सङ्केत : पैदल-१,यातयात-२, अन्य.....

**१०.जीवनस्तर**

१०.१ तपाईंको घर कस्तो किसिमको छ ?

क्र.सं.	घरको किसिम	विवरण	कैफियत
१	परम्परागत	ढुङ्गा र माटोको गारो सहित खरको छाना	
२	अर्ध-आधुनिक	ढुङ्गा र माटोको गारो सहित जस्ता वा स्लेटको छाना	
३	आधुनिक	सिमेन्ट र ढुङ्गा वा इटाको गारो सहित ढलान छाना	
४	भुप्रा/छाप्रा	बाँस वा काठले बारेका	

१०.२ तपाईंसँग घरायसी उपयोगका साधन र सामानहरु के के छन् ?

क्र.सं.	सामानको नाम	संख्या	क्र.सं.	सामानको नाम	संख्या
१	टेलिभिजन		९	रेडियो	
२	भी.सी.आर./भि.सी.डी		१०	राईस कुकर	
३	व्यक्तिगत धारा		११	फ्रिज	
४	टेबुल, कुर्सी		१२	ए.सी.	
५	सिलाई मेशिन		१३	कार	
६	मोटरसाईकल			अन्य .....	
७	साईकल			अन्य .....	
८	आईरन			अन्य .....	

१०.३ के तपाईंको करेसा बारी छ ?

१. छ                      २. छैन

१०.४ गाईवस्तु राख्ने छुट्टै गोठ छ ?

१. छ                      २. छैन

**११. पुल निर्माण आयोजना प्रति स्थानिय जनताको धारणा**

११.१ तपाईंले पुल निर्माण आयोजनाको बारेमा थाहापाउनु भएको छ ?

१. छ                      २. छैन

११.२ यदि थाहापाउनु भएको छ भने, कसरी थाहापाउनु भयो ?

१. छिमेकीले भनेर                      २. रेडियो/टि.भी.  
३. पत्रपत्रिका                      ४. अन्य (खुलाउने) .....

११.३ यस पुल निर्माण आयोजनाप्रति तपाईंको सहमति कस्तो छ ?



### Appendix 1-3: IEE Study Team Members

<b>SN</b>	<b>Name of Expert</b>	<b>Position</b>
1	Sujit Karmacharya	Team Leader (Environmental / Forestry Specialist/ Ecologist)
2	Rubee Koju Shrestha	Environmental (Asst. TL)
3	Santosh Kunwar	Road Engineer/ Transport/ Bridge Engineer
4	Jageswor Jha	Geologist/ Eng. Geologist/ Geotechnical Engineer
5	Dr. PC Jha	Hydrologist
6	Ishwari Prasad Khatiwada	Socio-Economist, Gender Issue Specialist

**Appendix 1-4: Photographs**



Fig 1: Project area Location of Ghyampe Khola Bridge (Ch. 111- 400)



Fig 2: Existing conditions of BP Highway at Ghyampe Khola crossing (Ch. 111- 400)



Fig 3: Project area Location of Mamti Khola Bridge (Ch. 113+900)

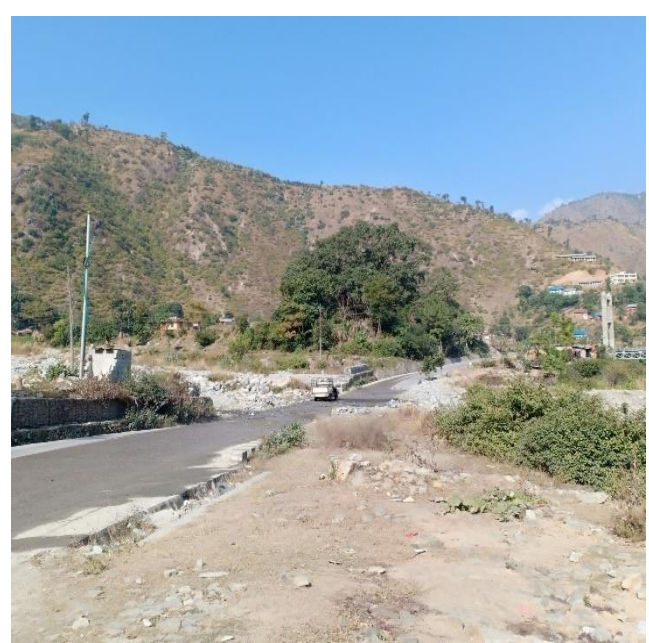

Fig 4: Existing conditions of BP Highway at Mamti Khola crossing (Ch. 113+900)



Fig 5: Project area Location of Bhyakure Khola Bridge (Ch. 119+700)



Fig 6: Existing conditions of BP Highway at Bhyakure Khola crossing (Ch. 119+700)

**The Project for the Operation and Maintenance of the  
Sindhuli Road Phase 2**

**Topographic Survey & Mapping Report**



**Client:**  
Nippon Koei Co. Ltd.



**Prepared by:**  
Soil Test (P) Ltd.



**July-2018**



## TABLE OF CONTENTS

1. Introduction .....	1
1.1. Project Background and Location .....	1
1.2. Scope of the Work .....	2
2. Detailed Topographic Survey .....	2
3. Detailed Topographic Mapping .....	3
3.1. Processing of Field Surveyed Data .....	3
3.2. Preparation & Plotting of Maps .....	5
4. Output .....	5

### APPENDICES:

APPENDIX 1: BENCHMARK DESCRIPTION SHEET

APPENDIX 2: RAW DATA FROM TOPOGRAPHIC SURVEY

APPENDIX 3: CONTOUR DRAWING

APPENDIX 4: TOPOGRAPHIC MAP

APPENDIX 5: Contour drawings with overlay of Drone image

APPENDIX 6: LONGITUDINAL PROFILE & CROSS SECTIONS OF ROAD/HIGHWAY

APPENDIX 7: WATER COURSE PROFILE & CROSS SECTIONS OF RIVER/STREAM

APPENDIX 8: DRONE IMAGES OVERLAID IN TOPOGRAPHICAL MAP

APPENDIX 9: FIELD PHOTOGRAPHS



## 1. Introduction

### 1.1. Project Background and Location

This report is for the topographic survey and mapping conducted along Nepalthok-Dhulikhel road section. This work is undertaken by Soil Test (P) Ltd. (the Contractor) on behalf of Nippon Koei Co. Ltd. (Client) for “The Project for the Operation and Maintenance of the Sindhuli Road Phase 2” hereinafter referred to as “the Project”.

The project area is 68 km from Kathmandu and is directly accessible by road. This project comprises of 4 different flood affected sites. The survey works were carried out on the vicinity of existing stream, as listed in the table below. All the 4 sites are located on right-side Roshi River (hereafter Roshi Khola). The location of all the 4 sites with respect to the distance from confluence of Roshi Khola and Sunkoshi River are listed in table below:

**Table 1: Location of Sites, with respect to Roshi-Sukhoshi confluence**

S.N.	Name of Station/Site	Distance from Roshi-Sunkoshi Confluence (km.)
1	1+400, Ghyampe Khola Causeway, Site-4	2.5
2	3+900 Mamti Khola Causeway, Site-3	4.7
3	9+700 Bhyakure Khola Causeway, Site-2	10.4
4	10+100 Kaldhunga Roadway, Site-1	10.7

The roadway distance from Site-1 to Site-4 is 8.8km along B.P. Highway.



**Figure 1: Location of 4 sites in Google Earth**

### 1.2. Scope of the Work

The scope of work requires to determine the terrain conditions at the above-mentioned sites and to provide data as mentioned in ToR for the design of causeway restoration and flood control.

The scope of the work as per TOR is listed below:

- a. Benchmark setting = 12 points (each site 3 points).
- b. Plan and contour mapping survey, Area = 0.249 km<sup>2</sup>, Scale of 1:500.
- c. Longitudinal and cross section survey, total length =3,200 m, Scale of 1:500.
- d. Preparation of survey data and output (drawings).

### 2. Detailed Topographic Survey

Prior to setting of benchmarks on the ground, preliminary reconnaissance survey was executed by experienced surveyors for each site. As per scope of the work, 3 benchmarks need to be setup at every site. However, depending upon an existing terrain condition, 4 benchmarks were setup on each site, by choosing the suitable point on the ground.

In order to proceed the assigned scope of work, the coordinates (Easting, Northing & Elevation) of 1 benchmark (per site) were assumed at first for carrying out topographical survey. The Survey equipment used for the said purpose was "Sokkia Reflectorless Total Station SET5 530R3". The detailed specification of this survey equipment is given below:

- EDM system with reflectorless distance measurement up to 300m
- Dual display and alphanumeric keyboard
- 3 " (1mg) Angle accuracy (readings to 1 ")
- Distance range of 4000m to single prism with accuracy of ( 2mm+ 2ppm)
- 10, 000 points with up to 32 jobs internal memory
- Input and display in meters or feet and inches
- Vertical and horizontal electronic compensator.



On the other hand for obtaining precise coordinates in terms of Easting, Northing & A.M.S.L (Average Mean Sea Level), DGPS survey was also carried out parallel to the topographical survey on each site. Before undertaking the survey, instruments and tools have been calibrated to guarantee the precision of testing and collecting data.

The detailed topographical survey has been carried by Total Station equipment by tachometric method of survey. After setting the instrument over an assumed survey station, the back sight was fixed on the prism reflector placed over a known point and then started taking details on the ground. The position of important features such as existing water level, structures (house, gabion wall, electric pole, crusher area, culvert, existing causeway, etc..), river course, Highway as well as village road were recorded and the corresponding remarks were noted. As termed in ToR, features governing longitudinal profile and cross sections of existing stream/river and existing road/highway were performed precisely. A rough sketch of surveyed points was maintained so that it might be useful while plotting of the maps.

### 3. Detailed Topographic Mapping

#### 3.1. Processing of Field Surveyed Data

All the forms of data, collected in the memory of Total Station Instrument, was downloaded to a computer. The field surveyed data have been checked and the manuscript map plots were prepared. The correctness of the work has been checked in presence of field surveyor. The assumed coordinates of benchmarks on each site, during Total Station Survey, were transformed in accordance to DGPS Survey coordinates in order to match with the real-world scenario.

The importing of surveyed points, categorizing them based upon the unique remarks, generating contours out of surveyed data at the interval of 1m and finally, addition of break lines were performed in the software “Autodesk Civil3D” environment in order to prepare topographic maps.

In addition, the required cross sections of river course profile and river cross sections were then generated in the same software environment. Similarly, the work of producing longitudinal sections and cross sections of existing Road/Highway (B.P. highway) were also performed in the same software environment, fulfilling all the minimum criterion described in ToR.



**Figure 2: Imported topographic points and setting of alignment of road & stream in Autodesk Civil3D (sample sketch)**



**Figure 3: Generated contour lines out of topographic points (sample sketch)**

Finally, all the output was exported so as to work in Autodesk AutoCAD environment.

### 3.2. Preparation & Plotting of Maps

The steps involved in the preparation of final topographical maps, longitudinal profile and cross sections in AutoCAD are mentioned below:

- (i) Draw all line features and manage the layer & colour, properly;
- (ii) Symbolize all physical and manmade features;
- (iii) Annotate contour levels, place names, river names, etc.;
- (iv) Prepare list of legends and prepare suitable nameplate accordingly;
- (v) Prepare topographic map layout in 1:500 scale, for printing in A3 size paper;
- (vi) Prepare river course profile drawing, river cross section drawing, longitudinal profile for road and cross sections of road all in 1:500 scale to be printed in A3 size paper.

Prior to the execution of printing arrangement inside AutoCAD environment, a Drone image was also overlaid over a topographic map so as to understand the site and features visually inside. Similarly, inside Civil3D environment, the image captured from Drone was draped over a surface generated out of survey points so as to understand the site and features in 3D view.

## 4. Output

In general, the main report is prepared by incorporating the general approach and methodology, and other general matters relating to the objective of the work. The secondary data which would be useful later are annexed with the report. The appendices which are attached with the report are as follows:

Appendix 1: Benchmark coordinates Sheet & Description Sheets

Appendix 2: Raw data (coordinate table X,Y, Z) from the topographic survey

Appendix 3: Contour drawings (with contour interval of 1meter)

Appendix 4: Topographic maps prepared at a scale of 1:500

Appendix 5: Contour drawings with overlay of Drone image

Appendix 6: Longitudinal Profile and cross sections of road prepared at a scale of 1:500

Appendix 7: Water course profile and cross sections of river/stream prepared at a scale of 1:500

Appendix 8: Drone images overlaid in Topographical Map

Appendix 9: Field Photographs



**APPENDIX 1: BENCHMARK COORDINATES  
SHEET & DESCRIPTION SHEET**

## Project for the Operation and Maintenance of the Sindhuli Road Phase 2

<p><b>Client:</b></p> <div style="display: flex; align-items: center; justify-content: center;"> <p><b>Nippon Koei Co. Ltd.</b></p> </div>	<p><b>Consultant:</b></p> <div style="display: flex; align-items: center; justify-content: center;"> <p><b>Soil Test (P) Ltd.</b> CONSULTING ENGINEERS Sanepa, P.P. Box 2967, Kathmandu Nepal</p> </div>
--	--

### BENCHMARKS COORDINATE SHEET

Point Id	Easting	Northing	Ellipsoidal Height	Ortho Ht.	Posn.+ Height Quality	remarks
G-1	381951.857	3035088.419	569.711	620.853	0.0085	STA. 1+400 Ghyampe Khola Causeway (SITE 4)
G-2	381785.992	3035185.399	552.289	603.425	0.012	
G-3	381807.009	3035397.662	541.876	593.012	0	
G-4	381709.504	3035473.445	527.709	578.841	0.0048	
G-5	381701.24	3035550.156	520.667	571.799	0.0085	
G-6	379387.772	3036132.225	575.638	626.687	0.0133	STA. 3+900 Mamti Khola Causeway (SITE 3)
G-7	379320.174	3036181.741	582.402	633.448	0.0111	
G-8	379550.027	3036240.139	565.16	616.213	0	
G-9	379666.328	3036174.142	556.303	607.361	0.0106	
G-10	379727.709	3036254.705	549.079	600.138	0.0115	
G-11	376408.165	3038669.19	650.705	701.6804	0.0083	STA.9+700 Bhyakure Khola Causeway (SITE 2)
G-12	376375.906	3038892.369	654.914	705.8871	0.0047	
G-13	376586.161	3039037.172	641.555	692.535	0	
G-14	376560.622	3039166.569	631.306	682.2846	0.0057	
G-15	376130.09	3039255.041	638.49	689.453	0.004	STA. 10+100 Kaldhunga Roadway (SITE 1)
G-16	376147.196	3039115.34	654.173	705.137	0.0059	
G-17	376274.91	3039289.985	636.91	687.878	0.0044	
G-18	376203.976	3039208.555	641.445	692.411	0.0066	

**STA. 1+400, Ghyampe Khola Causeway  
BENCHMARK DESCRIPTION SHEET**

Project: Project for the Operation and Maintenance of the Sindhuli Road Phase 2  
Site: STA.1+400 Ghyampe Khola Causeway (SITE 4)

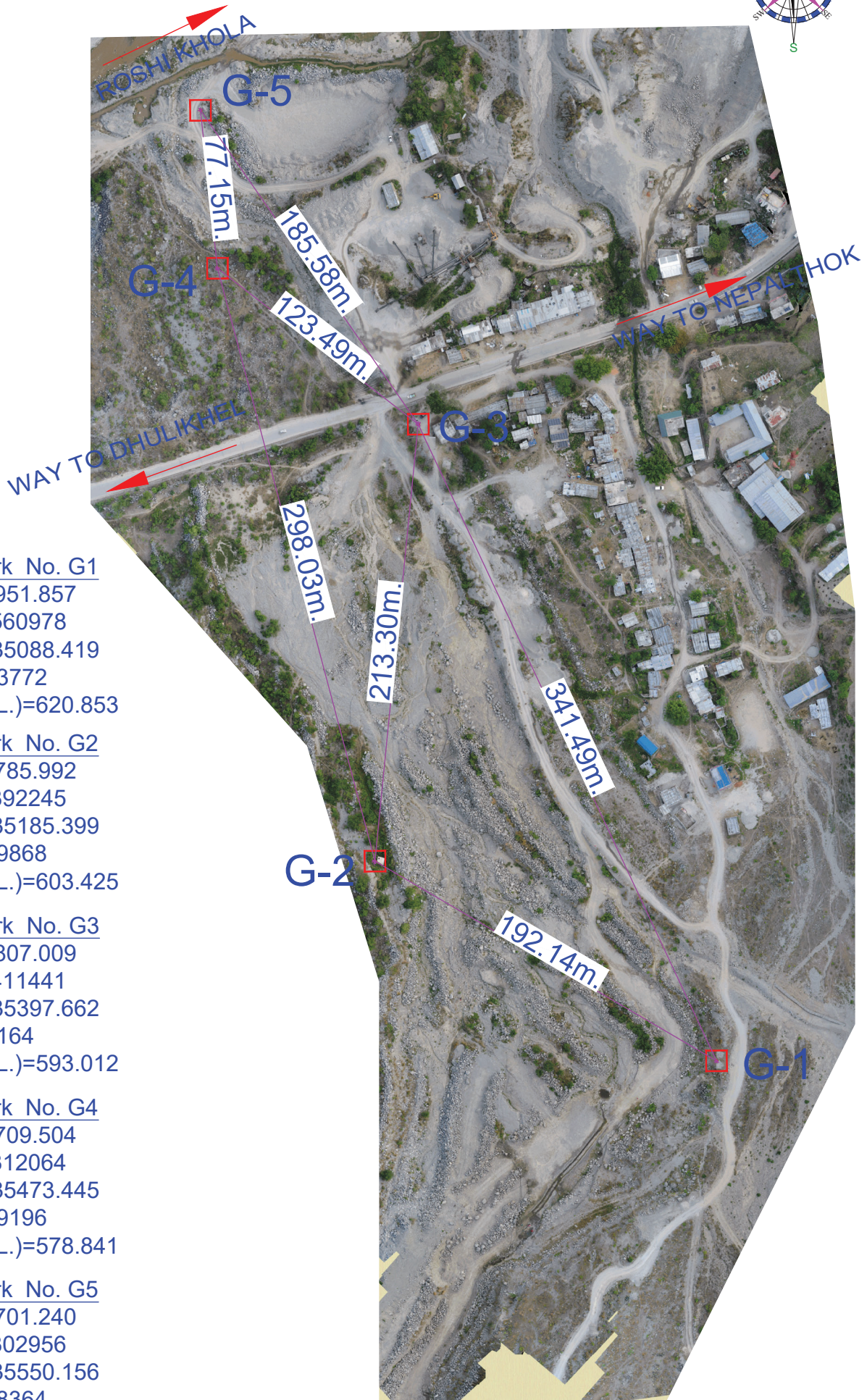
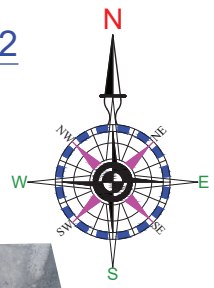

Station/Benchmark No. G1  
Easting (m.)=381951.857  
Longitude=85.80560978  
Northing (m.)=3035088.419  
Latitude=27.43413772  
Elevation (A.M.S.L.)=620.853

Station/Benchmark No. G2  
Easting (m.)=381785.992  
Longitude=85.80392245  
Northing (m.)=3035185.399  
Latitude=27.43499868  
Elevation (A.M.S.L.)=603.425



Station/Benchmark No. G3  
Easting (m.)=381807.009  
Longitude=85.80411441  
Northing (m.)=3035397.662  
Latitude=27.4369164  
Elevation (A.M.S.L.)=593.012

Station/Benchmark No. G4  
Easting (m.)=381709.504  
Longitude=85.80312064  
Northing (m.)=3035473.445  
Latitude=27.43759196  
Elevation (A.M.S.L.)=578.841

Station/Benchmark No. G5  
Easting (m.)=381701.240  
Longitude=85.80302956  
Northing (m.)=3035550.156  
Latitude=27.43828364  
Elevation (A.M.S.L.)=571.799

## DESCRIPTION CARD OF BENCHMARK STATION

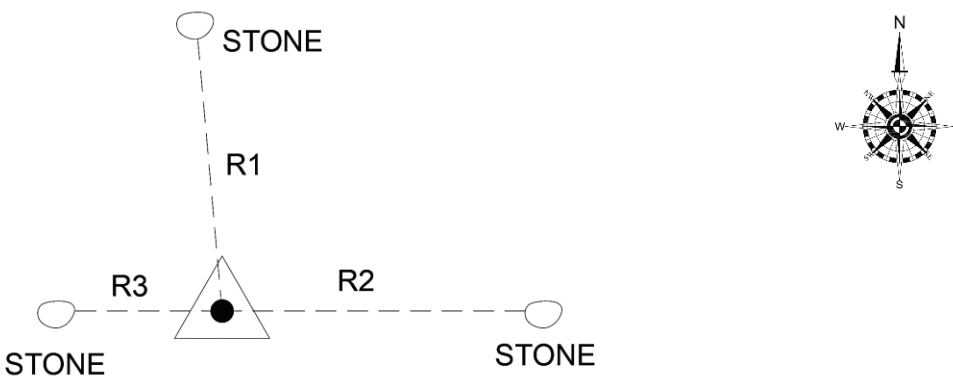
Site: STA. 1+400 Ghyampe Khola Causeway (SITE 4)

<b>District:</b> <b>Kavrepalanchowk</b>	<b>VDC:</b> <b>Sunkoshi Gaun Palika, Ward No. 1</b>	
<b>Station No./Control Point No.</b>	<b>Description</b>	<b>Station Mark</b>
G-1	This Station lies on the North-East of the Khira Tree. It lies on the right side of the Aapghari-Aarughari Road at a distance of about 7m. Further, this station lies at a distance of 6.5m, 7.2m & 3.8m from the stones as shown in the figure below:	Stone
Easting: 381951.857	Northing: 3035088.419	Elevation (a.m.s.l.): 620.853
Location Sketch showing the station and reference point		
		
Reference no. and Distance:		
R1: 6.5m	R2: 7.2m	R3:3.8m
Photograph:		
		

Prepared by: Deepak Singh Dhami

## DESCRIPTION CARD OF BENCHMARK STATION

Site: STA. 1+400 Ghyampe Khola Causeway (SITE 4)

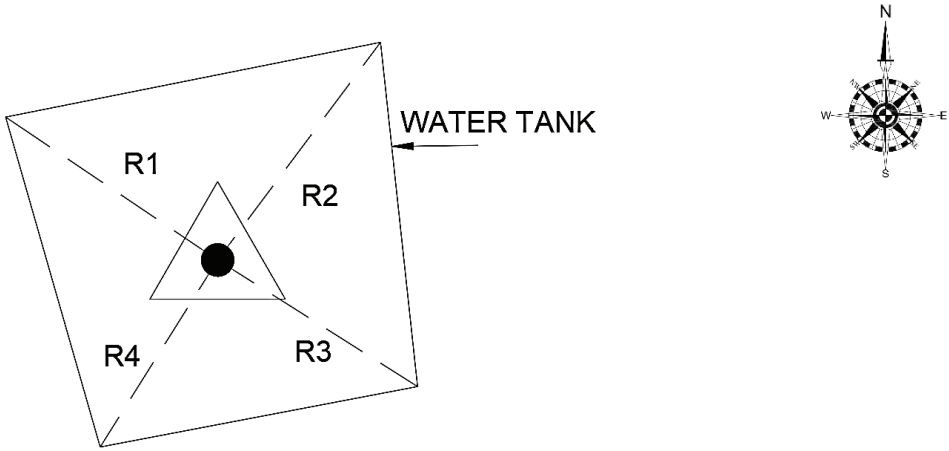
<b>District:</b> <b>Kavrepalanchowk</b>	<b>VDC:</b> <b>Sunkoshi Gaun Palika, Ward No. 1</b>		
<b>Station No./Control Point No.</b>	<b>Description</b>		<b>Station Mark</b>
G-2	This Station lies on the left side of the Ghyampe Khola. It is marked by the paint on the existing water tank.		Painted on water tank
<b>Easting:</b> 381785.992	<b>Northing:</b> 3035185.399	<b>Elevation (a.m.s.l.):</b> 603.425	
<b>Location Sketch showing the station and reference point</b>			
			
<b>Reference no. and Distance:</b>			
R1: 2.47m	R2: 3.18m	R3: 2.77m	R4: 1.49m
<b>Photograph:</b>			

Prepared by: Deepak Singh Dhama

## DESCRIPTION CARD OF BENCHMARK STATION

Site: STA. 1+400 Ghyampe Khola Causeway (SITE 4)

<b>District:</b> Kavrepalanchowk	<b>VDC:</b> Sunkoshi Gaun Palika, Ward No. 1	
Station No./Control Point No.	Description	Station Mark
G-3	This Station lies on the right side of the B.P. Highway and is referenced with respect to existing electric pole, tree and house corner.	Concrete Pillar
Easting: 381807.009	Northing: 3035397.662	Elevation (a.m.s.l.): 593.012

Location Sketch showing the station and reference point

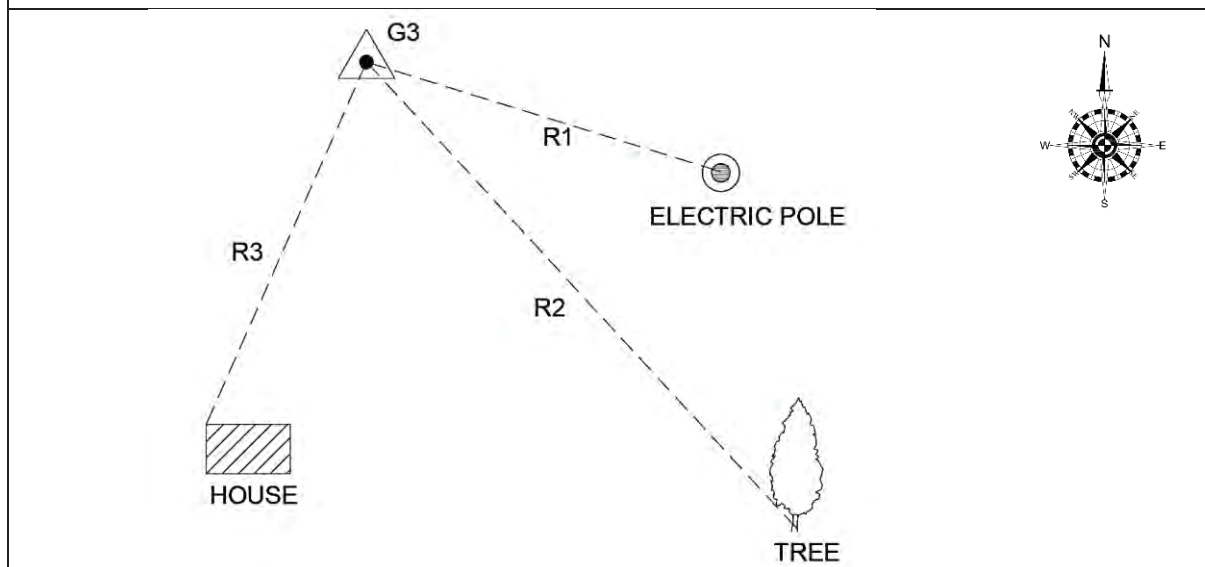

Reference no. and Distance:

R1: 10.4m	R2: 17.8m	R3: 11.1m
-----------	-----------	-----------

Photograph:

Prepared by: Deepak Singh Dhimi

## DESCRIPTION CARD OF BENCHMARK STATION

Site: STA. 1+400 Ghyampe Khola Causeway (SITE 4)

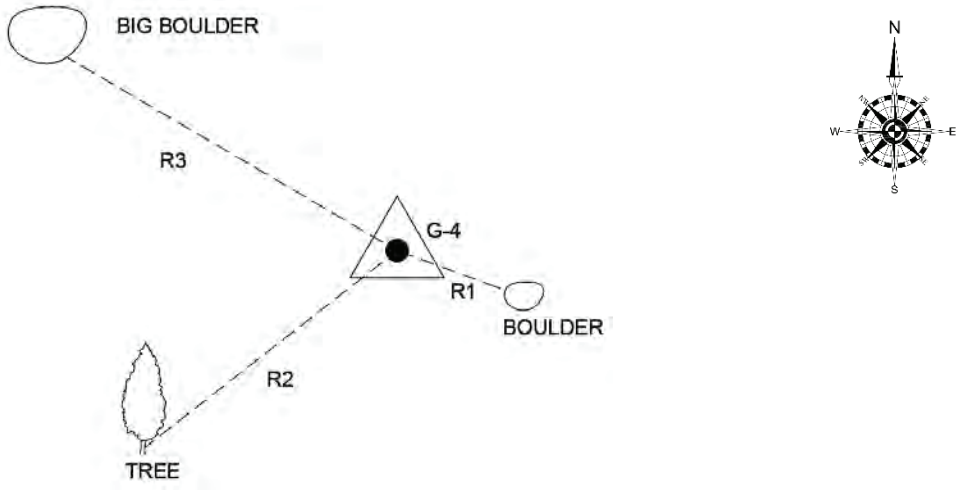
<b>District:</b> <b>Kavrepalanchowk</b>	<b>VDC:</b> <b>Sunkoshi Gaun Palika, Ward No. 1</b>	
<b>Station No./Control Point No.</b>	<b>Description</b>	<b>Station Mark</b>
G-4	This Station lies on the left side of the Ghyampe Khola, surrounded by Sisam trees.	Stone
<b>Easting: 381709.504</b>	<b>Northing: 3035473.445</b>	<b>Elevation (a.m.s.l.): 578.841</b>
<b>Location Sketch showing the station and reference point</b>		
		
<b>Reference no. and Distance:</b>		
R1: 3.7m	R2: 10.8m	R3: 12.9m
<b>Photograph:</b>		

Prepared by: Deepak Singh Dhami

## DESCRIPTION CARD OF BENCHMARK STATION

Site: STA. 1+400 Ghyampe Khola Causeway (SITE 4)

District: <b>Kavrepalanchowk</b>	VDC: <b>Sunkoshi Gaun Palika, Ward No. 1</b>	
Station No./Control Point No.	Description	Station Mark
G-5	This Station lies on the right side of the aapghari-Roshi Khola (earthern road) at the turning. It is marked on the stone.	Marked on the stone
Easting: 381701.240	Northing: 3035550.156	Elevation (a.m.s.l.): 571.799

Location Sketch showing the station and reference point

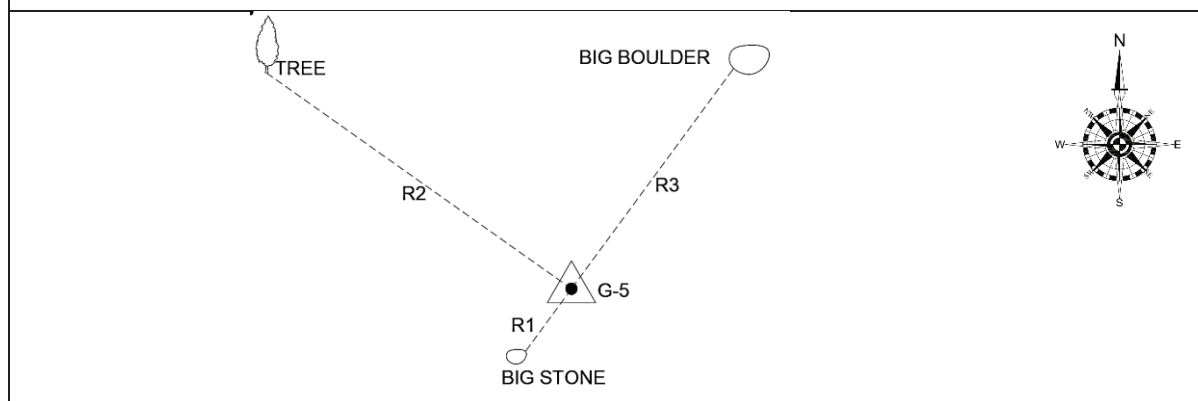

Reference no. and Distance:

R1: 5.1m	R2: 24.5m	R3: 17.9m
----------	-----------	-----------

Photograph:



Prepared by: Deepak Singh Dhami

**STA. 3+900, Mamti Khola Causeway  
BENCHMARK DESCRIPTION SHEET**

Project: Project for the Operation and Maintenance of the Sindhuli Road Phase 2  
 Site: STA. 3+900, Mamti Khola Causeway (SITE 3)

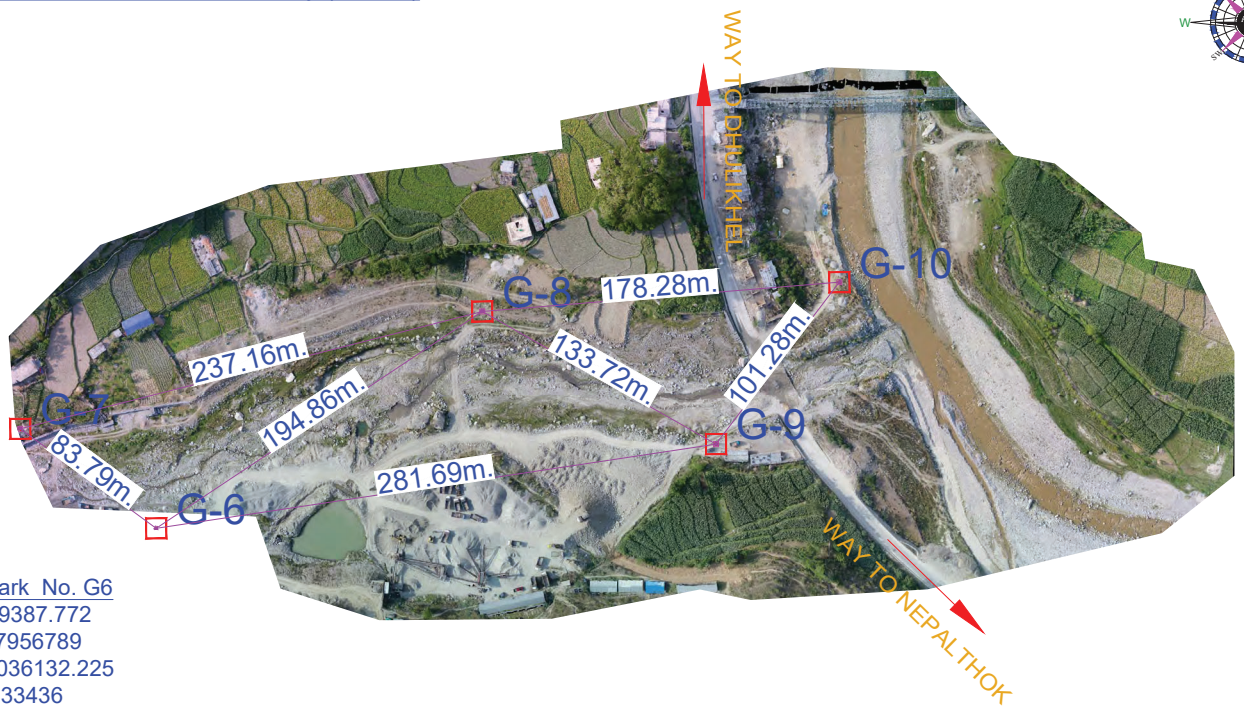
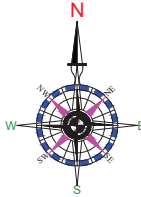

Station/Benchmark No. G6  
 Easting (m.)=379387.772  
 Longitude=85.77956789  
 Northing (m.)=3036132.225  
 Latitude=27.44333436  
 Elevation (A.M.S.L.)=626.687

Station/Benchmark No. G7  
 Easting (m.)=379320.174  
 Longitude=85.77887909  
 Northing (m.)=3036181.741  
 Latitude=27.4437753  
 Elevation (A.M.S.L.)=633.448

Station/Benchmark No. G8  
 Easting (m.)=3379550.027  
 Longitude=85.78119868  
 Northing (m.)=3036240.139  
 Latitude=27.44432276  
 Elevation (A.M.S.L.)=616.213

Station/Benchmark No. G9  
 Easting (m.)=379666.328  
 Longitude=85.78238183  
 Northing (m.)=3036174.142  
 Latitude=27.44373736  
 Elevation (A.M.S.L.)=607.361

Station/Benchmark No. G10  
 Easting (m.)=379727.709  
 Longitude=85.78299483  
 Northing (m.)=3036254.705  
 Latitude=27.44446995  
 Elevation (A.M.S.L.)=600.138

## DESCRIPTION CARD OF BENCHMARK STATION

STA. 3+900, Mamti Khola Causeway (SITE 3)

District: <b>Kavrepalanchowk</b>	VDC: <b>Roshi Gaun Palika, Ward No. 12</b>	
Station No./Control Point No.	Description	Station Mark
G-6	This Station lies at 7 meters Northwest from the mango tree which is on the left side of the Harkapur-Mamti Road. The crusher is about 100m northeast from this station.	Concrete pillar
Easting: 379387.772	Northing: 3036132.225	Elevation (a.m.s.l.): 626.687

Location Sketch showing the station and reference point

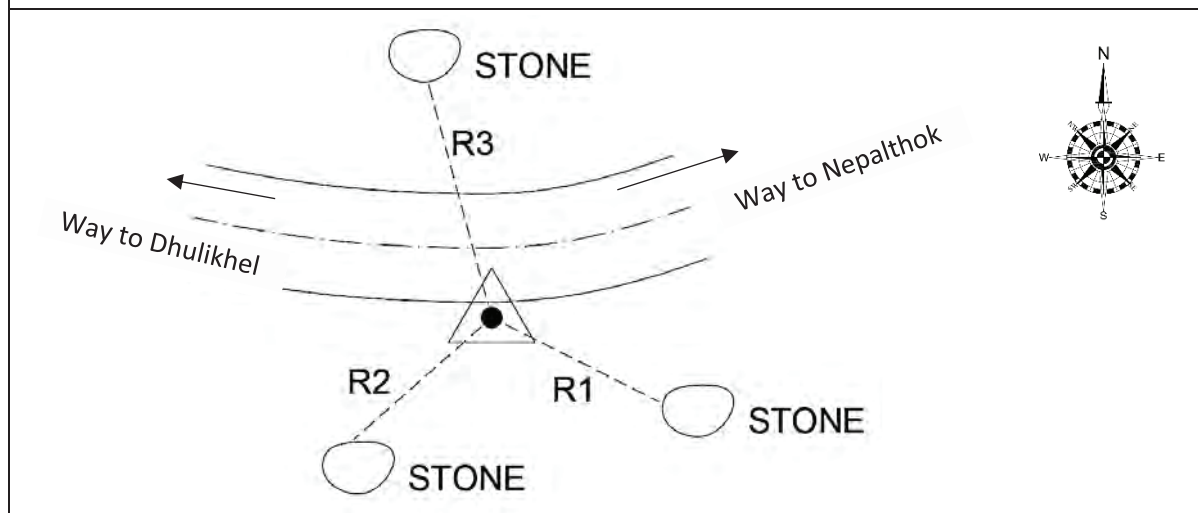

Reference no. and Distance:

R1: 6.9m	R2: 6.8m	R3: 8.9m
----------	----------	----------

Photograph:



Prepared by: Deepak Singh Dhami

## DESCRIPTION CARD OF BENCHMARK STATION

STA. 3+900, Mamti Khola Causeway (SITE 3)

District: <b>Kavrepalanchowk</b>	VDC: <b>Roshi Gaun Palika, Ward No. 12</b>	
Station No./Control Point No.	Description	Station Mark
G-7	This Station lies in front of the Keshav Shrestha's house which is about 23m away.	stone
Easting: 379320.174	Northing: 3036181.741	Elevation (a.m.s.l.): 633.448

Location Sketch showing the station and reference point

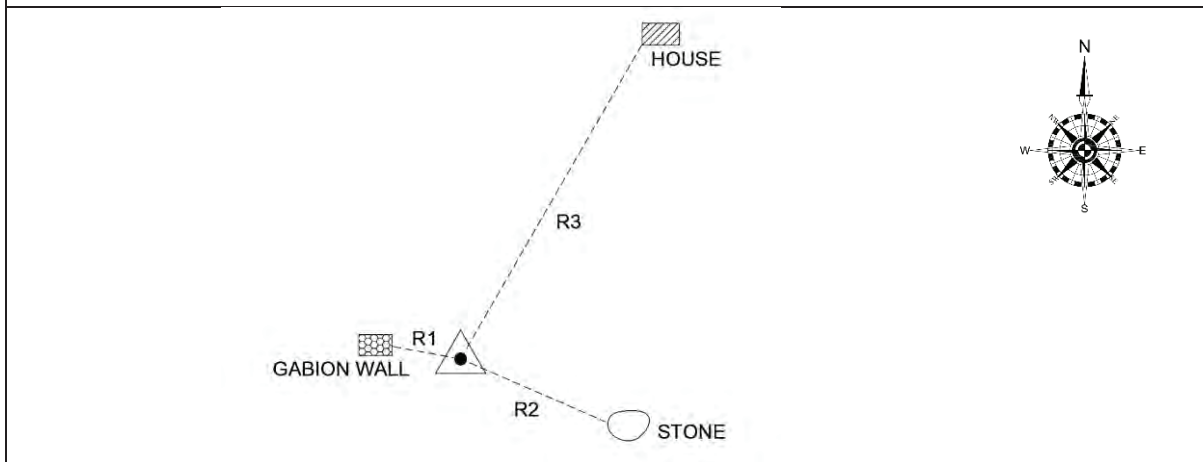

Reference no. and Distance:

R1: 4.4m	R2: 10m	R3: 23m
----------	---------	---------

Photograph:



Prepared by: Deepak Singh Dhami

## DESCRIPTION CARD OF BENCHMARK STATION

STA. 3+900, Mamti Khola Causeway (SITE 3)

District: <b>Kavrepalanchowk</b>	VDC: <b>Roshi Gaun Palika, Ward No. 12</b>	
Station No./Control Point No.	Description	Station Mark
G-8	This Station lies on the foot trail where new house of the Amar Bahadur Raimaji is being built.	Stone
Easting: 379550.027	Northing: 3036240.139	Elevation (a.m.s.l.): 616.213

Location Sketch showing the station and reference point

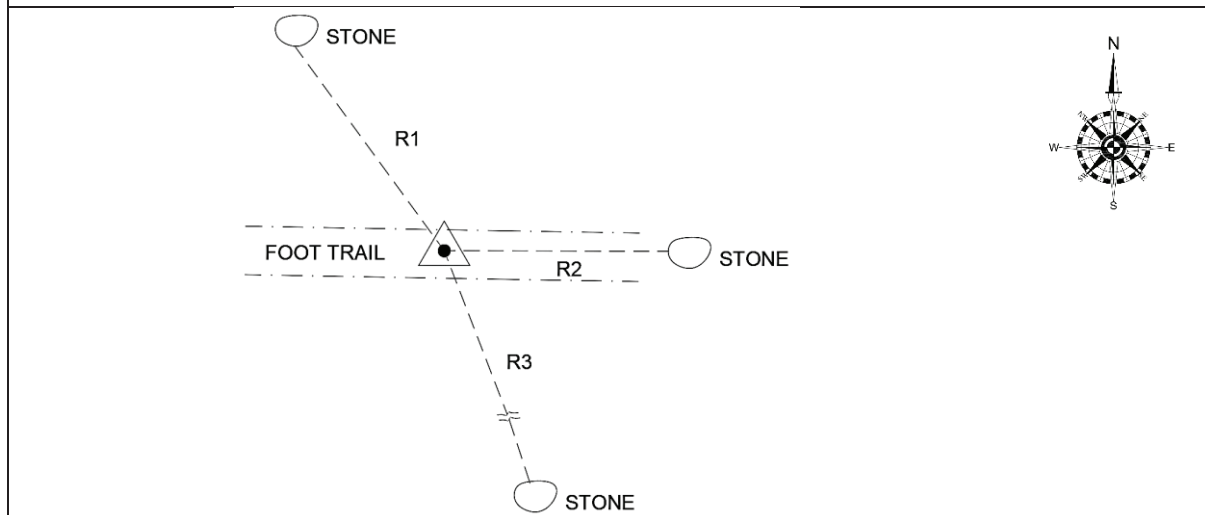

Reference no. and Distance:

R1: 15.6m	R2: 13.9m	R3: 29.9m
-----------	-----------	-----------

Photograph:



Prepared by: Deepak Singh Dhama

## DESCRIPTION CARD OF BENCHMARK STATION

STA. 3+900, Mamti Khola Causeway (SITE 3)

<b>District:</b> <b>Kavrepalanchowk</b>	<b>VDC:</b> <b>Roshi Gaun Palika, Ward No. 12</b>	
<b>Station No./Control Point No.</b>	<b>Description</b>	<b>Station Mark</b>
G-9	This Station lies in front of the Maniram Ghising's house. It lies on the right side of the B.P. Highway. The end edge of the gabion wall is 1m from this station.	Concrete pillar
<b>Easting: 379666.328</b>	<b>Northing: 3036174.142</b>	<b>Elevation (a.m.s.l.): 607.361</b>

Location Sketch showing the station and reference point

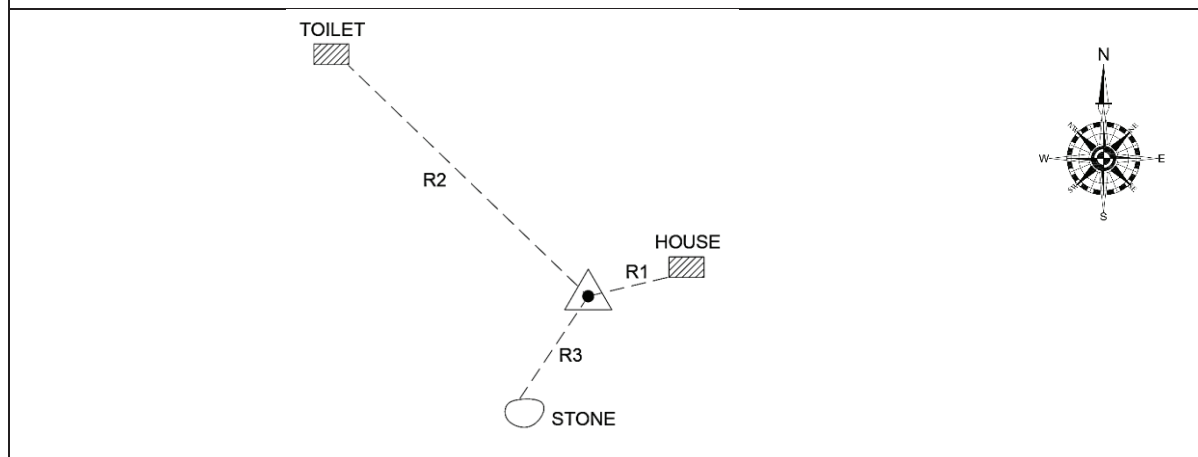

Reference no. and Distance:

R1: 5.5m	R2: 22.5m	R3: 8.3m
----------	-----------	----------



Photograph:



Prepared by: Deepak Singh Dhama

## DESCRIPTION CARD OF BENCHMARK STATION

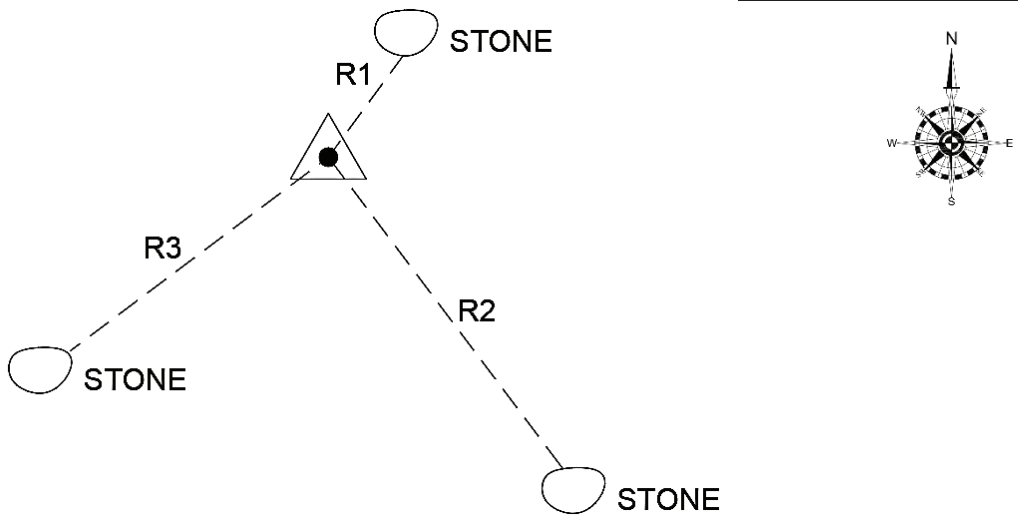
STA. 3+900, Mamti Khola Causeway (SITE 3)

<b>District:</b> <b>Kavrepalanchowk</b>	<b>VDC:</b> <b>Roshi Gaun Palika, Ward No. 12</b>	
<b>Station No./Control Point No.</b>	<b>Description</b>	<b>Station Mark</b>
G-10	This Station lies on the turning of the Thum-danda-Mamti Road, 8m from the river right of the Roshi Khola. The centre of the newly constructed tied arch bridge is about 30 meters Northwest from this station.	Concrete pillar
<b>Easting: 379727.709</b>	<b>Northing: 3036254.705</b>	<b>Elevation (a.m.s.l.): 600.138</b>
<b>Location Sketch showing the station and reference point</b>		
		
<b>Reference no. and Distance:</b>		
R1: 3.2m	R2: 16.3m	R3: 13.5m
<b>Photograph:</b>		
		

Prepared by: Deepak Singh Dhimi

**STA.9+700 Bhyakure Khola Causeway  
BENCHMARK DESCRIPTION SHEET**

Project: Project for the Operation and Maintenance of the Sindhuli Road Phase 2  
Site: STA.9+700 Bhyakure Khola Causeway (Site 2)

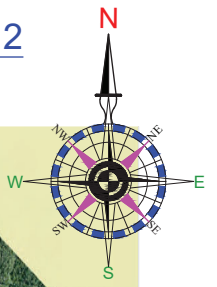

Station/Benchmark No. G14  
Easting (m.)=376560.622  
Longitude=85.75065774  
Northing (m.)=3039166.569  
Latitude=27.47046843  
Elevation (A.M.S.L.)=682.2846

Station/Benchmark No. G13  
Easting (m.)=376586.161  
Longitude=85.75092934  
Northing (m.)=3039037.172  
Latitude=27.46930283  
Elevation (A.M.S.L.)=692.535

Station/Benchmark No. G12  
Easting (m.)=376375.906  
Longitude=85.74881652  
Northing (m.)=3038892.369  
Latitude=27.46797676  
Elevation (A.M.S.L.)=705.887

Station/Benchmark No. G11  
Easting (m.)=376408.165  
Longitude=85.74916569  
Northing (m.)=3038669.190  
Latitude=27.46596532  
Elevation (A.M.S.L.)=701.680

G-11

## DESCRIPTION CARD OF BENCHMARK STATION

STA.9+700, Bhyakure Khola Causeway (SITE 2)

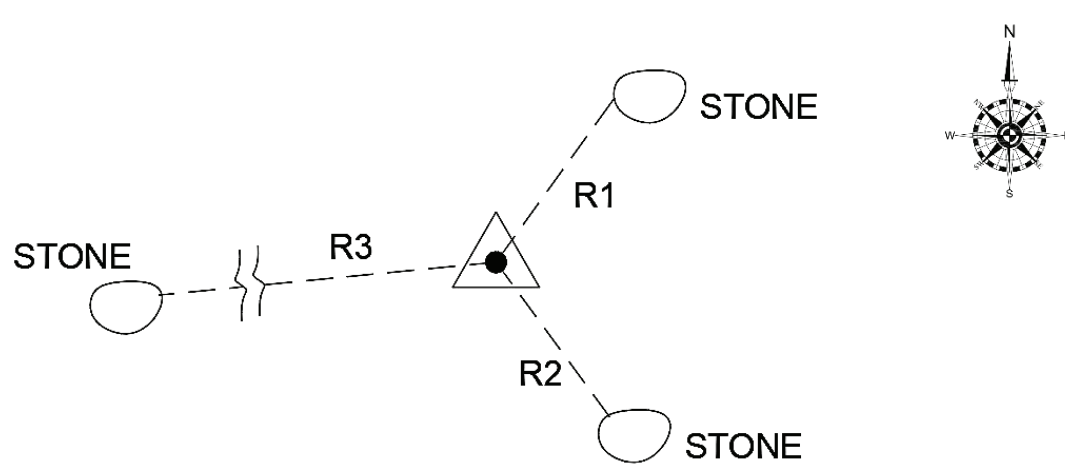
<b>District:</b> <b>Kavrepalanchowk</b>	<b>VDC:</b> <b>Roshi Gaun Palika, Ward No. 11</b>	
Station No./Control Point No.	Description	Station Mark
G-11	This Station lies at 20m away from the Kaldhunga-Kholaghari Road. It is on the right side of Bhyakure Khola. This station is marked on the stone which is surrounded by three other big stones.	Stone
Easting: 376408.165	Northing: 3038669.190	Elevation (a.m.s.l.): 701.680
Location Sketch showing the station and reference point		
		
Reference no. and Distance:		
R1: 3.7m	R2: 3.5m	R3: 17.1m
Photograph:		

Prepared by: Deepak Singh Dhami

## DESCRIPTION CARD OF BENCHMARK STATION

STA.9+700, Bhyakure Khola Causeway (SITE 2)

District: <b>Kavrepalanchowk</b>	VDC: <b>Roshi Gaun Palika, Ward No. 11</b>	
Station No./Control Point No.	Description	Station Mark
G-12	This Station lies on the Kaldhunga-Ratomato Road at the right side of the turning. The station lies about 20m away from the existing stone wall in north east direction.	Concrete pillar
Easting: 376375.906	Northing: 3038892.369	Elevation (a.m.s.l.): 705.887

Location Sketch showing the station and reference point

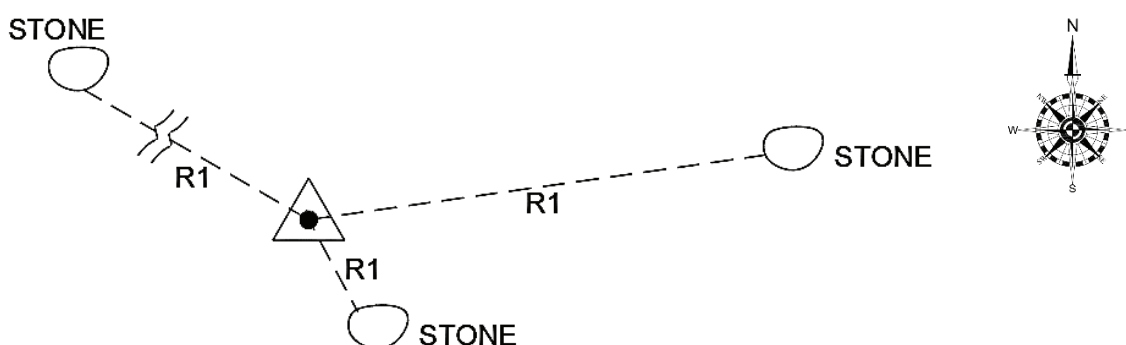

Reference no. and Distance:

R1: 2.3m

R2: 10.2m

R3: 16.4m

Photograph:



Prepared by: Deepak Singh Dhama

## DESCRIPTION CARD OF BENCHMARK STATION

STA.9+700, Bhyakure Khola Causeway (SITE 2)

<b>District:</b> <b>Kavrepalanchowk</b>	<b>VDC:</b> <b>Roshi Gaun Palika, Ward No. 11</b>	
<b>Station No./Control Point No.</b>	<b>Description</b>	<b>Station Mark</b>
G-13	This Station lies on the right side of the B.P. Highway at the distance of about 5m from the road. The station is 10.3meter away from the North-west of the house corner. The football post is about 25m far from this station.	Concrete Pillar
Easting: 376586.161	Northing: 3039037.172	Elevation (a.m.s.l.): 692.535

Location Sketch showing the station and reference point

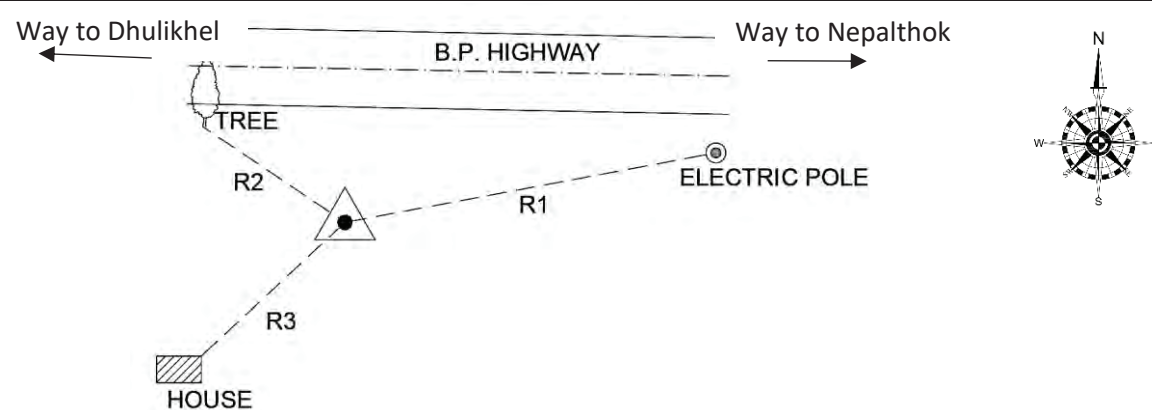

Reference no. and Distance:

R1: 19.3m

R2: 9m

R3: 10.3m



Photograph:



Prepared by: Deepak Singh Dhama

## DESCRIPTION CARD OF BENCHMARK STATION

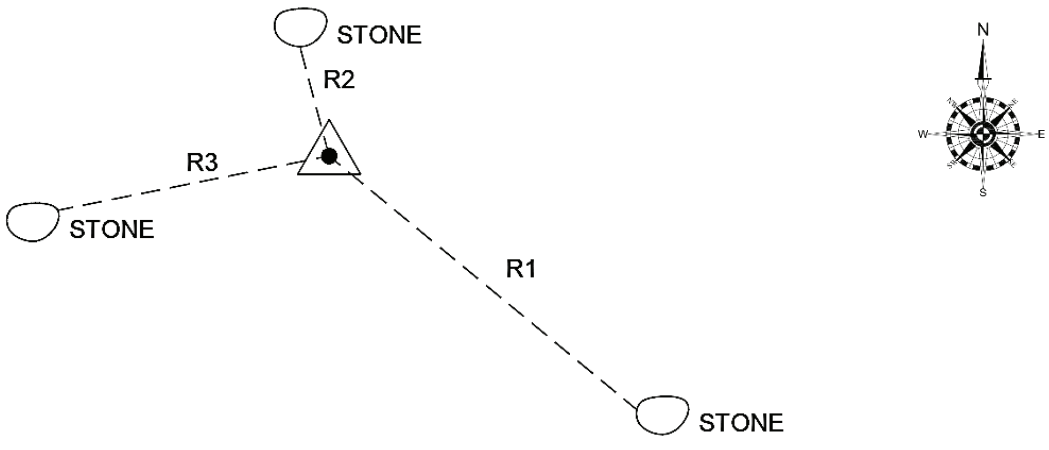
STA.9+700, Bhyakure Khola Causeway (SITE 2)

District: <b>Kavrepalanchowk</b>	VDC: <b>Roshi Gaun Palika, Ward No. 11</b>	
Station No./Control Point No.	Description	Station Mark
G-14	This Station lies at the back of Milijuli Hotel and about 60m at the edge from Maize farm land. This station is 20m Northwest of Bhyakure Khola. It is located at a side of the foot trail named Bhyakure Khola Dobhan-Kaldhunga road.	Concrete pillar
Easting: 376560.622	Northing: 3039166.569	Elevation (a.m.s.l.): 682.285
Location Sketch showing the station and reference point		
 <p>The sketch shows a central station marked with a triangle containing a black dot. Three dashed lines connect this station to three reference points, each represented by a circle labeled 'STONE'. The lines are labeled R1, R2, and R3. R1 is the longest line extending to the southeast, R2 is a shorter line extending to the north, and R3 is a line extending to the west. A compass rose is located in the upper right corner of the sketch area.</p>		
Reference no. and Distance:		
R1: 20m	R2: 5.6m	R3: 13.9m
Photograph:		
		

Prepared by: Deepak Singh Dhami